

AD-A061 850

FOREIGN TECHNOLOGY DIV WRIGHT-PATTERSON AFB OHIO  
POWER-LINE CARRIER TELEPHONY TYPE ETN-4, (U)  
JUN 78 J RYBKA

F/G 17/2

UNCLASSIFIED

FTD-ID(RS)T-0364-7A

NL

| of |  
AD  
A061850



END  
DATE  
FILMED  
2-79  
DDC

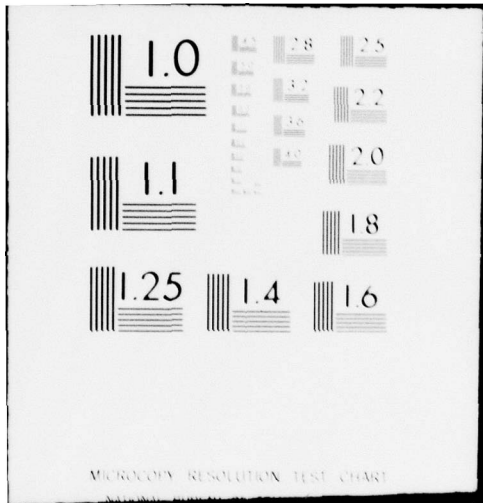

MICROCOPY RESOLUTION TEST CHART

AD-A061850

FTD-ID(RS)T-0364-78

1

# FOREIGN TECHNOLOGY DIVISION



POWER-LINE CARRIER TELEPHONY TYPE ETN-4

By

Jerzy Rybka



DDC  
R  
5 DEC 1978  
E

Approved for public release;  
distribution unlimited.

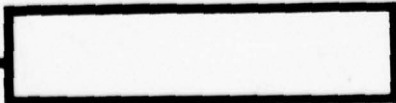

78 11 22 142

# EDITED TRANSLATION

FTD-ID(RS)T-0364-78

27 July 1978

MICROFICHE NR: *FTD 78-C-001050*

POWER-LINE CARRIER TELEPHONY TYPE ETN-4

By: Jerzy Rybka

English pages: 14

Source: Przegląd Telekomunikacyjny, Vol. 50,  
Nr. 5, 1977, pp. 140-145

Country of Origin: Poland  
Translated by: John G. Hanus  
Requester: RCA Service Company  
Approved for public release;  
distribution unlimited.

DDC	write section <input checked="" type="checkbox"/>
UNANNOUNCED	Buff Section <input type="checkbox"/>
JUSTIFICATION	<input type="checkbox"/>
BY	
DISTRIBUTION/AVAILABILITY CODES	
Dist	AVAIL and/or SPECIAL
<i>A</i>	

<p>THIS TRANSLATION IS A RENDITION OF THE ORIGINAL FOREIGN TEXT WITHOUT ANY ANALYTICAL OR EDITORIAL COMMENT. STATEMENTS OR THEORIES ADVOCATED OR IMPLIED ARE THOSE OF THE SOURCE AND DO NOT NECESSARILY REFLECT THE POSITION OR OPINION OF THE FOREIGN TECHNOLOGY DIVISION.</p>	<p>PREPARED BY: TRANSLATION DIVISION FOREIGN TECHNOLOGY DIVISION WP AFB, OHIO.</p>
---	--

## Power-line Carrier Telephony Type ETN-4

Jerzy Rybka, State Teletransmission Works

Energy development, or, to put it more precisely, the development of the electric power grid both here and abroad, requires reliable communications between individual installations such as power stations, substations, etc., and the State Power Administration. These communications should be dependable and, as far as possible, independent; they should be intended only for use by the energy establishment. This is the purpose of a carrier telephony system using high-voltage power lines.

### Equipment design

The equipment for the type ETN-4 power-line carrier telephony system, design M72, is manufactured at the State Teletransmission Works in Warsaw. The M72 design contains a rack and shelves, which hold units. Each shelf constitutes a set of electrically and mechanically connected units. The units are connected with the shelf cabling by blade-type connectors, which also are used to connect the shelf cabling with the rack cabling. The printed circuits of the

individual units contain the newest and best components available here and abroad. This equipment is constructed with silicon semiconductors and integrated systems, which greatly influence its dependability and high stability of parameters over time.

The equipment for the Type ETN-4 power-line carrier telephony system is constructed in racks with the following dimensions: height 1489 mm, width 600 mm, depth 225 mm. The station cabling can be brought in from the top or bottom of the rack. The ETN-4 equipment includes racks which are still replacing the KNO, PNO, WNO, and ETT-41 racks manufactured by TELKOM-TELETRA; they are:

- the ETN-4 low-frequency equipment rack,
- the ETN-4 high-frequency equipment rack.

#### ETN-4 LF equipment

The ETN-4 low-frequency equipment, which is shown schematically in fig. 1, permits the use of the 0.3 - 3.4 kHz band for transmitting voice and 7 nonvoice (telegraph) channels. Below are important technical data for the equipment.

##### Line side

Frequency band 0.3 - 3.4 kHz;

Line levels:

a) voice channel

- sending -13 - +13 dBr,
- receiving -22 - +4 dBr,

b) channel for pilot current and long-distance dialing -14 dBm0,

c) nonvoice channel -16 dBm0;

Operating impedance (input and output) 600  $\Omega/0^\circ$ ;

Correction of line attenuation distortions with corrector in LF line

amplifier;

Line amplifier gain 0 - 26 dB.

Station side

Equipment is compatible with manual and automatic connectors in a 1-wire or 2-wire system. It is also possible to hook directly into terminals of local battery or central battery telephone sets;

Operation in one-wire system:

- sending level 0 dBr,
- receiving level -7 dBr;

Operation in two-wire system:

- sending level -13 - 0 dBr,
- receiving level +4 - -8 dBr;

Operating impedance (input and output) 600  $\Omega/0^\circ$ ;

Psophometric level of interference on station side of equipment  
-60 dBm0p;

Attenuation distortion of voice channel is in compliance with  
JEC recommendations for 0.3 - 2.4 kHz channel;

Nonlinear distortion in voice channel should be less than 2%;

Limiter in voice channel restricts output level to +3 dBm0, with an  
increase in input level to +15 dBm0.

Nonvoice channels

In LF equipment it will be possible to use nonvoice (telegraph) channels with 50, 100, and 200 baud transmission speed. The following distribution is provided for:

a) 50-baud channels

$f_0$ [Hz]	channel nr.
2580	119

$f_0$ [Hz]	channel nr.
2700	120
2820	121
2940	122
3060	123
3180	124
3300	125

b) 50 and 100-baud channels

$f_0$ [Hz]	channel nr.	speed [bauds]
2580	119	50
2700	120	50
2880	211	100
3120	212	100
3300	125	50

c) 50 and 200-baud channels

$f_0$ [Hz]	channel nr.	speed [bauds]
2580	119	50
2700	120	50
3000	406	200
3300	125	50

The transmitter for channel 119 (pilot current and long-distance dialing) is adapted for make-break control:

- $R$  make  $\leq 2 \text{ k}\Omega$ ,
- $R$  break  $\geq 20 \text{ k}\Omega$ ;

The transmitters for the remaining channels are adapted for 10-20 V two-way pulse control or make-break control:

- $R$  make  $\leq 2 \text{ k}\Omega$ ,
- $R$  break  $\geq 2 \text{ k}\Omega$ ;

The channel 119 receiver is adapted for make-break automatic switch-board control. The receivers of the remaining channels are adapted for sending  $\pm 20 \text{ mA}$  current at  $\pm 20 \text{ V}$ .

#### Telegraph repeater

The equipment includes an electronic telegraph repeater which makes

it possible to operate two teletypewriters hooked up to the set of equipment. The telegraph repeater permits operation in the following systems:

a) permanent connection of two teletypewriters - alternate operation. The typewriters are connected to the translator by means of teletypewriter calls, which perform a connecting and signalling function;

b) interaction with a remote telegraph switchboard. It will be possible to interact with manual and automatic telegraph switchboards.

#### Componder

In order to improve transmission quality in the nonvoice channels, the equipment is provided with a compander, which increases the signal-to-noise ratio.

#### Power supply

The low-frequency ETN-4 is powered from 220 V (+10%, -15%), 50 Hz mains.

#### Signalling

Signalling is provided for in the event of supply voltage decay, as well as fading or reduction of the signal level at the receiver of a nonvoice channel. These failures are announced by a signal light on the rack and by an intermittent signal of approx. 600 Hz from a loudspeaker. It is possible to shut off the audible alarm by pushing a switch, which first turns off the signal light and then activates the audible signal disconnect light. External signalling by means of a normally open contact has also been provided.

### Climatic conditions

The equipment is designed for operation indoors at ambient temperatures of 10-50°C, with no corrosive chemical constituents present, at 65% ±15% humidity.

### ETN-4 HF equipment

The ETN-4 high-frequency equipment serves for transferring the 0.3 - 3.4 kHz band into one of the line bands contained in the 40 - 320 kHz range. The block diagram of this equipment is shown in fig. 2. Important technical data is given below.

### Line side

Frequency band 40 - 320 kHz;

Nominal impedance on line side: 180, 125, 60 Ω;

Relative power level in transmitting direction for nonvoice channel at 800 Hz: +40 dBr with one line repeater and +43 dBr with two line repeaters;

Relative power level in receiving direction for nonvoice channel at 800 kHz: nominal - +7 dBr, maximum - +30 dBr, minimum - -19 dBr;

Range of automatic regulation of level ±26 dB/±1.5 dB.

### Station side

Audio frequency band 0.3 - 3.4 kHz;

Level at transmitting branch input -13 dBr;

Level at receiving branch output +4 dBr;

Nominal impedance (input and output) 600 Ω/0°;

Attenuation distortion in 0.3 - 3.4 kHz band should be in compliance with JEC recommendations;

Nonlinear distortion  $\leq 2\%$ ;

Background noise  $\leq -60$  dBm0p.

#### Transmission path

The transmission path for signals of the ETN-4 power-line carrier telephony system is a high-voltage overhead or cable power line. It can also be a cable line receiving interference from a nearby high-voltage power line.

#### Modulation plan

The natural frequency band 300 - 3400 Hz, which contains a voice channel and 7 super-voice channels, is transferred to the line band 40 - 320 kHz by three-stage amplitude modulation. As a result of these changes one sideband is obtained, while the carrier and the other sideband which occur during modulation are suppressed. This produces transmitted signals of great range because of maximum use of transmitted power and small channel width, which permits full utilization of the line frequency band. The first stage of modulation shifts the natural band to the 20-24 kHz band, which in turn is shifted to the 464-468 kHz band during the second stage of modulation. The third stage of modulation produces a line band approx. 4 kHz wide in the 40-320 kHz frequency range. Work is also going on to increase the band to 452 kHz. The group of individual modulation bands is shown in fig. 3. The three-stage modulation system has made it possible to use a single low-pass filter (after the third stage) for the entire range of carrier frequencies, so that the harmful products of high-power modulation ( $F \pm f$ ,  $3F \pm f$ ,  $5F \pm f$ ,  $F$ ) are outside of the useful band and do not interfere with the operation of other

systems. Because of this the high-frequency<sup>system</sup> will function in only one way.

The ETN-4 can work with or without frequency spacing on the line side. In the first case the distance between the extreme frequencies of the bands - sending and receiving - is 32 kHz, while in the second case the sending and the receiving band lie near each other, and the link occupies an 8 kHz band. The distribution of line bands is given in fig. 4.

#### Generating equipment

During the modulation process the carrier frequencies must be produced in a generating system consisting of a 5 MHz high-stability generator and three synthesizers. Appropriate division of the 5 MHz frequency from the generator produces the first modulation stage carrier frequency of 20 kHz and 16 kHz for control of the synthesizers. Synthesizer  $S_1$  creates the carrier frequency of the second modulation stage, equal to 488 kHz. Synthesizers  $S_2$  and  $S_3$  generate 508 - 784 kHz with 4 kHz spacing. These are the carrier frequencies of the third stage of modulation. The required frequency is obtained by closing the proper circuits on a printed synthesizer board. Stability of carrier wave frequencies for a year is better than  $\pm 3 \cdot 10^{-6}$ . This generating system has the following advantages:

- a single generator and synthesizer design instead of four quartz generators with preset frequencies required to obtain line bands (over 100 types of quartz resonators),
- the possibility of changing a line band without changing a generator during production or operation,
- replaceability of groups of equipment in case of damage to a

generator or synthesizer in operation or production,

- saving of space in the rack, and lower cost.

The block diagram of the ETN-4 generating equipment is presented in fig. 5.

#### Line power amplifier

In order to increase the signal-to-noise ratio for the noise level on a high-voltage power line, a power amplifier is used at the line output of the ETN-4 equipment; the peak power of this amplifier can total 40 or 80 W. An amplifier with higher or lower power can thus be used, according to line length and interference level. Power can be changed by providing the rack with one or two 40 W amplifiers connected by special branch connectors. The amplifier's range of transmitted frequencies covers the full range of line frequencies.

#### Line filter

The line filter of the transmitting direction prevents HF signals of nearby equipment from entering the transmitting portion of the ETN-4. The line filter of the receiving direction isolates the receiving band from the frequencies arriving at its input. Adjustable air-core coils and capacitors are used in constructing the filters for the ETN-4. Different sets of capacitors are used, depending on the frequency of the band transmitted by the filter. Line filter attenuation in the transmitted band does not exceed 2.6 dB, while maximum power at the filter input comes to 40 W.

#### Automatic level regulator

The ETN-4 receiving branch has an automatic level regulating system which maintains the audio output level to within  $\pm 1.5$  dB during

changes in the level of the input pilot current within  $\pm 26$  dB of the nominal rating. During a pilot current decay the ARP will be controlled by a combined signal of the super-voice channels and will be adjusted for amplification about 3 dB higher. The pilot current is a signal of the 2580 Hz super-voice channel. It is possible to disconnect the ARP and manual regulation, while measurements are being made, for example. The range of variations in the input pilot current of the ARP can be adjusted as needed for the following values:  $\pm 22$ ,  $\pm 16.5$ , and  $\pm 15$  dB.

#### Correction of line distortions

The second stage of conversion uses an amplifier with adjustable corrector, whose purpose is to amplify the individual frequencies of the transmitted band so that line distortions in the 0.3 - 3.4 kHz channel are in compliance with JEC recommendations. The proper correction curve is obtained by closing the appropriate circuits on the printed board of the assembly.

#### Signalling

The ETN-4<sup>HF</sup> equipment is provided with a rack light and an intermittent 600 Hz audible signal to warn of a decay in the supply voltage. The audible signal can be shut off with a switch, which turns off the rack light and the external signalling. The signal disconnect light stays on.

#### Power supply

The ETN-4 HF equipment is powered from 220 V (+10%, -15%), 50 Hz mains.

### Climatic conditions

The equipment is designed for indoor operation at ambient temperatures of 10-50°C, with no corrosive chemical constituents present, at 65% ±15% humidity.

### ETN-4 operating systems

Depending on requirements, the ETN-4 equipment can be arranged in the following ways (fig. 6):

- a) the ETN-4 LF equipment can be located together with the ETN-4 HF equipment on the same frame, forming a complete terminal equivalent to the KNO (TELETRA) frame;
- b) the ETN-4 LF equipment is installed at one site, and the ETN-4 HF equipment at another site. These are linked by LF cable. In this case the LF equipment rack is equivalent to the WNO, while the HF rack corresponds to the PNO;
- c) ETN-4 LF units are located at different sites and are linked by LF cable.

In this system the ETN-4 LF equipment rack is the counterpart of the ETT-41.

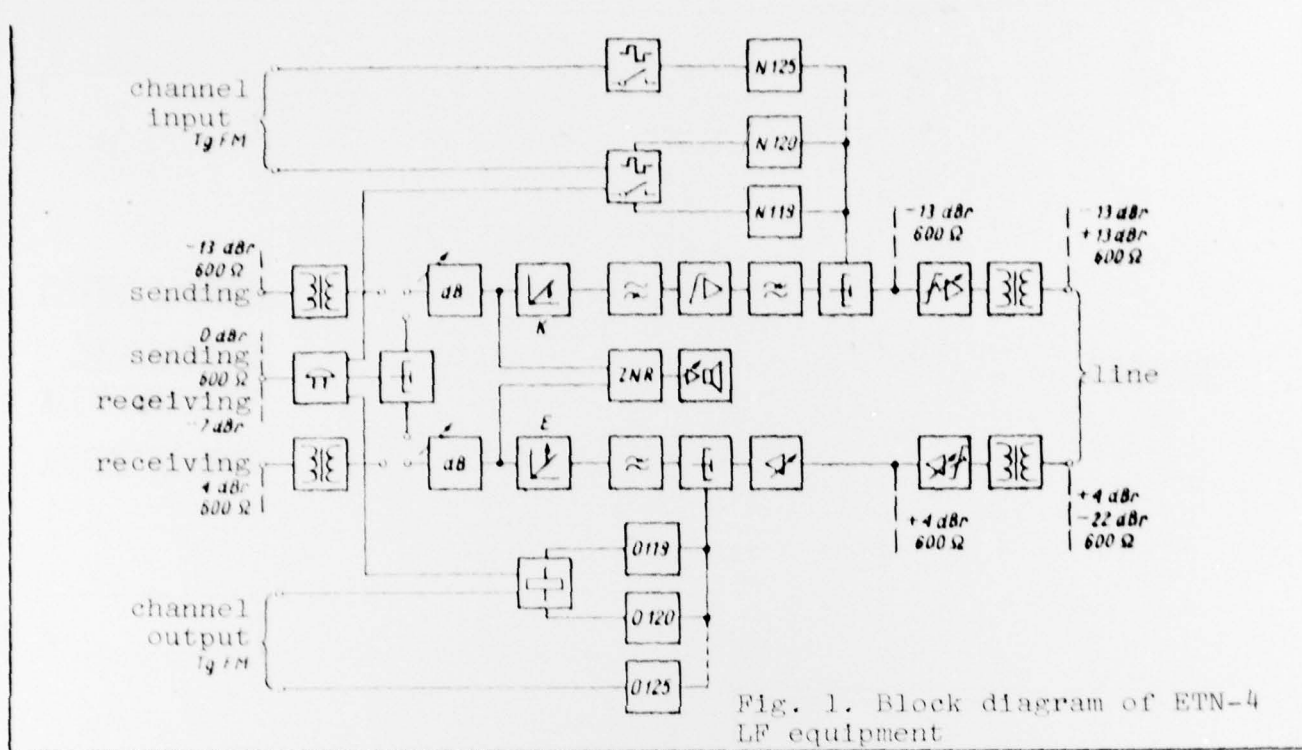

Fig. 1. Block diagram of ETN-4 LF equipment

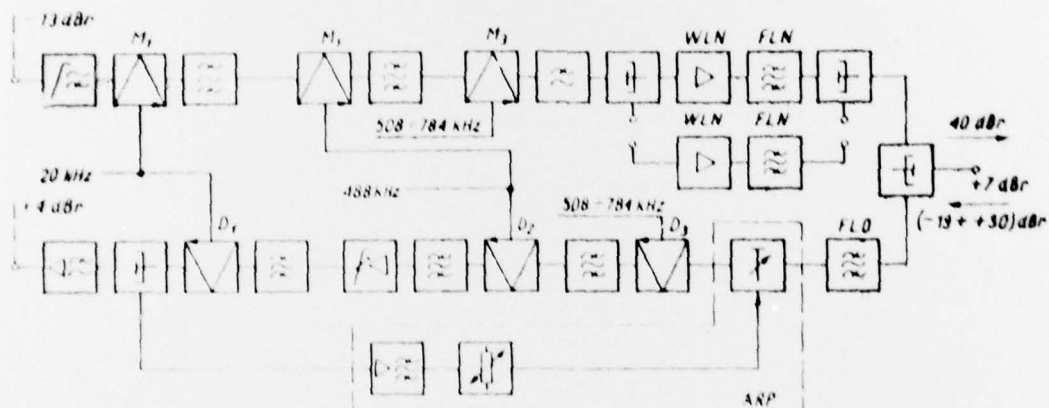

Fig. 2. Block diagram of ETN-4 HF equipment

- WLN - Sending line amplifier
- FLN - Sending line filter
- FLO - Receiving line filter
- ARP - Automatic regulation of level

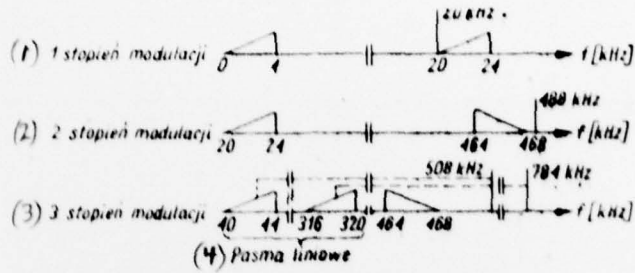

Fig. 3. System of individual modulation bands

- 1 - 1st modulation stage
- 2 - 2nd modulation stage
- 3 - 3rd modulation stage
- 4 - line bands

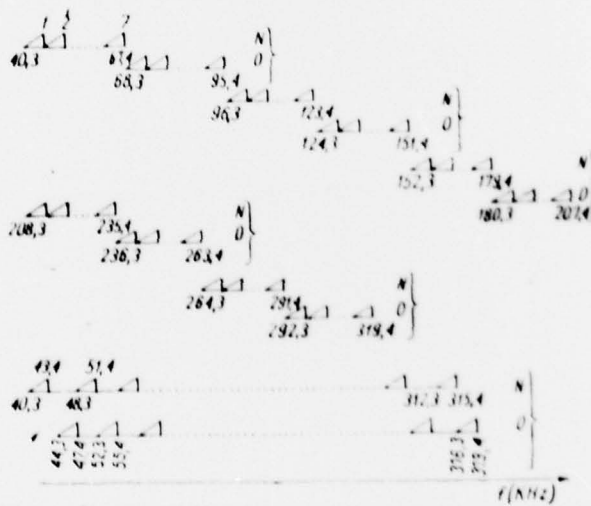

Fig. 4. Type of line bands; N - sending direction, 0 - receiving direction.

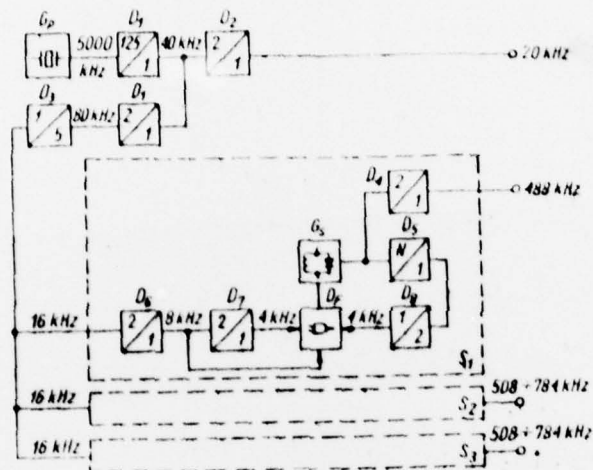

Fig. 5. Block diagram of ETN-4 generating equipment;  $G_p$  - quartz master oscillator  $f = 5$  MHz,  $S_1 - S_3$  - frequency synthesizer systems,  $D_1 - D_4$ ,  $D_6 - D_8$  - binary frequency dividers with fixed coefficient of division,  $D_5$  - binary frequency divider with adjustable coefficient,  $P_1$  - frequency doubler,  $G_s$  - synchronized generator type LC altered by voltage of deviation signal from phase detector  $D_F$

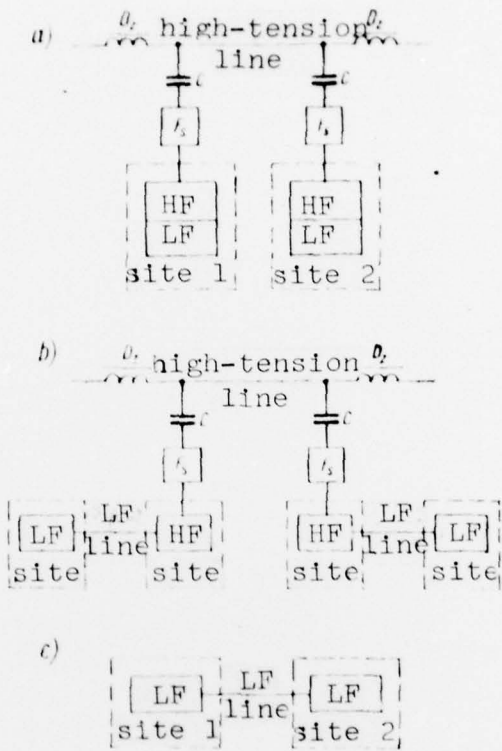

Fig. 6. ETN-4 operating systems;  $D_z$  - blocking choke, C - coupling capacitor,  $F_s$  - coupling filter

DISTRIBUTION LIST

DISTRIBUTION DIRECT TO RECIPIENT

<u>ORGANIZATION</u>	<u>MICROFICHE</u>	<u>ORGANIZATION</u>	<u>MICROFICHE</u>
A205 DMATC	1	E053 AF/INAKA	1
A210 DMAAC	2	E017 AF/RDXTR-W	1
B344 DIA/RDS-3C	9	E403 AFSC/INA	1
C043 USAMIIA	1	E404 AEDC	1
C509 BALLISTIC RES LABS	1	E408 AFWL	1
C510 AIR MOBILITY R&D	1	E410 ADTC	1
LAB/FIO		E413 ESD	2
C513 PICATINNY ARSENAL	1	FTD	
C535 AVIATION SYS COMD	1	CCN	1
C591 FSTC	5	ASD/FTD/NICD	3
C619 MIA REDSTONE	1	NIA/PHS	1
D008 NISC	1	NICD	2
H300 USAICE (USAREUR)	1		
P005 ERDA	1		
P005 CIA/CRS/ADB/SD	1		
NAVORDSTA (50L)	1		
NASA/KSI	1		
AFIT/LD	1		