

AD A061940

TECHNICAL REPORT
NATICK/TR-78/031

**A SYSTEMS ANALYSIS
OF ALTERNATIVE FOOD SERVICE CONCEPTS
FOR NEW ARMY HOSPITALS**

by

M. Herz
A. Freeman
G. Eccleston
G. Hertweck
S. Boritz
P. Short
W. O. Veneklasen
J. Souder

Approved for public release;
distribution unlimited.

MARCH 1978

**UNITED STATES ARMY
NATICK RESEARCH and DEVELOPMENT COMMAND
NATICK, MASSACHUSETTS 01760**



Operations Research/Systems Analysis Office

Approved for public release; distribution unlimited.

Citation of trade names in this report does not constitute an official indorsement or approval of the use of such items.

Destroy this report when no longer needed. Do not return it to the originator.

UNCLASSIFIED

SECURITY CLASSIFICATION OF THIS PAGE (When Data Entered)

REPORT DOCUMENTATION PAGE		READ INSTRUCTIONS BEFORE COMPLETING FORM
1. REPORT NUMBER 14 NATICK/TR-78/031	2. GOVT ACCESSION NO.	3. RECIPIENT'S CATALOG NUMBER
4. TITLE (and Subtitle) A SYSTEMS ANALYSIS OF ALTERNATIVE FOOD SERVICE CONCEPTS FOR NEW ARMY HOSPITALS		5. TYPE OF REPORT & PERIOD COVERED 9 Technical Report
7. AUTHOR(s) M. Herz, A. Freeman, G. Eccleston, G. Hertweck, S. Baritz, P. Short, W. O. Veneklasen and J. Souder		6. PERFORMING ORG. REPORT NUMBER
8. CONTRACT OR GRANT NUMBER(s)		10. PROGRAM ELEMENT, PROJECT, TASK AREA & WORK UNIT NUMBERS 6.2 11L762724 AH99 AD014, 016, 017, 021
9. PERFORMING ORGANIZATION NAME AND ADDRESS US Army Natick Research and Development Command ATTN: Operations Research and Systems Analysis Office Natick, MA 01760		12. REPORT DATE 11 March 1978
11. CONTROLLING OFFICE NAME AND ADDRESS US Army Natick Research and Development Command ATTN: Operations Research and Systems Analysis Office Natick, MA 01760		13. NUMBER OF PAGES 199
14. MONITORING AGENCY NAME & ADDRESS (if different from Controlling Office)		15. SECURITY CLASS. (of this report) Unclassified
16. DISTRIBUTION STATEMENT (of this Report) Approved for public release; distribution unlimited.		15a. DECLASSIFICATION/DOWNGRADING SCHEDULE NA
17. DISTRIBUTION STATEMENT (of the abstract entered in Block 20, if different from Report)		
18. SUPPLEMENTARY NOTES ORIGINAL CONTAINS COLOR PLATES: ALL BDC REPRODUCTIONS WILL BE IN BLACK AND WHITE Service Requirement Identification: USA 8-4, Systems Analysis of Fixed Army Hospital Food Service Operations		
19. KEY WORDS (Continue on reverse side if necessary and identify by block number) FOOD SERVICE MILITARY FACILITIES CONSUMER ACCEPTANCE HOSPITAL FOOD SERVICE ACCEPTABILITY COST(S) HOSPITAL EQUIPMENT EVALUATION NUTRITION MENU(S)		
20. ABSTRACT (Continue on reverse side if necessary and identify by block number) Systems Analysis is used to determine the best food service system design for use in the construction of new Army facilities. Four food service system concepts for Army hospitals are defined, evaluated and compared based on cost and systems effectiveness. Significant improvements for new hospitals are indicated by all the alternatives compared to the current concept of operation with the ready foods concept demonstrating the lowest operating cost and highest systems effectiveness. Layouts of the preferred food service systems and artist's concepts of a suggested new ward feeding concept are presented.		

DDC
RECEIVED
 DEC 8 1978
REGULATORY

392 1 11

PREFACE

The Operations Research and Systems Analysis Office (OR/SA) of the US Army Natick Research and Development Command (NARADCOM) has prepared this report in response to MSR USA 8-4, Systems Analysis of Fixed Army Hospital Food Service Operations, for the Office of the Surgeon General (OTSG) as Project Number 1L762724AH99AD014 of the DOD Food Research, Development, Testing, and Engineering Program. This effort was also supported by the Behavioral Science Division, Food Sciences Laboratory, NARADCOM (Work Unit AD017); the Construction Engineering Research Laboratory, US Army Corps of Engineers (Work Unit AD016); and the Foods Systems Equipment Division, Food Engineering Laboratory, NARADCOM (Work Unit AD021).

The broad objectives of the projects are to provide a food system concept for Army hospitals in the new construction program (Phase I); new or improved concepts for food service systems in existing facilities (Phase II); and a management planning system which provides for better management, control, and utilization of hospital food service resources (Phase III). This report presents the results and conclusions pertaining to concepts for new hospital construction obtained from the completion of Phase I.

The authors thank Colonel P. Accountius, Chief, Dietician OTSG, for her continuing interest and assistance in the project, and Colonel J. H. Ferguson, Dietetic Consultant Health Service Command, for her support and cooperation.

ACCESSION for		
NTIS	White Section	<input checked="" type="checkbox"/>
DDC	Black Section	<input type="checkbox"/>
UNANNOUNCED		<input type="checkbox"/>
JUSTIFICATION		
BY		
DISTRIBUTION/AVAILABILITY CODES		
Dist.	AVAIL.	and/or SPECIAL
A		

TABLE OF CONTENTS

	Page
PREFACE	1
LIST OF FIGURES	6
LIST OF TABLES	7
I. Executive Summary	11
A. Objectives	11
B. The Army Hospital Food Service Mission	11
C. Results and Conclusions	12
D. Recommendations	13
II. The Army Hospital Food Service System	15
A. Description	15
B. Analysis of Acceptability	15
C. Analysis of Operations	19
D. Conclusions	21
III. Economic Analysis of Alternative System Concepts	25
A. Alternative System Concepts	25
B. Functional Area	26
C. Cost Analysis	26
D. Assumptions	30
E. The 100-Bed Facility	36
Cost Elements	37
Cost Analysis	37
F. The 250-Bed Facility	39
Cost Elements	39
Cost Analysis	40
G. The 550-Bed Facility	40
Cost Elements	42
Cost Analysis	43

TABLE OF CONTENTS (cont'd)

	Page
III. Economic Analysis of Alternative System Concepts (cont'd)	
H. Analysis – Economic Evaluation	43
I. Conclusions	49
IV. Consumer Acceptance	51
A. Effect of Preparation Methods on Acceptability	51
Objective	51
Food Items	53
Methodology for Evaluation of Concepts	53
Analysis and Discussion	55
Conclusions	62
B. Consumer Attitudes Regarding Hospital Food Service	63
Objective	63
Analysis of Survey Data	63
Statistical Significance of Survey Data	67
Conclusions	72
V. Cost-Benefit Analysis	74
A. Advantages and Disadvantages of Alternatives	74
B. Systems Effectiveness Evaluation	78
C. Comparison of Alternative Concepts	81
D. Results	84
E. Comparison with Current Operations	84
F. Comparison with Civilian Operations	84
G. Conclusions	87
VI. Ready Foods System Concept	88
A. Introduction	88
B. Food Preparation Area	88
C. Ward Dining Concept	93
List of References	95
APPENDICES	
Appendix A Labor Requirements	99

TABLE OF CONTENTS (cont'd)

	Page
APPENDICES (cont'd)	
Appendix B Food Costs	107
Appendix C Equipment Lists	111
Appendix D Space Requirements	145
Appendix E Energy Costs	151
Appendix F Projected Costs	153
Appendix G Operating Data - Summer 1977	157
Appendix H Statistical Analysis of Consumer Acceptability Ratings	171
Appendix I Dayroom/Dining Area Designs	177

LIST OF FIGURES

	Page
Figure 1. Distribution of Consumer Ratings – Overall Population	16
Figure 2. Distribution of Consumer Ratings – Staff and Ambulatory	17
Figure 3. Distribution of Consumer Ratings – Ward Patients	18
Figure 4. Hospital Food Service Functional Flow	27
Figure 5. Projected Annual Costs	45
Figure 6. Projected Cost – 100-Bed Facility	46
Figure 7. Projected Cost – 250-Bed Facility	47
Figure 8. Projected Cost – 550-Bed Facility	48
Figure 9. System Effectiveness	79
Figure 10. Kitchen and Dining Hall Layout – 100-Bed	90
Figure 11. Kitchen and Dining Hall Layout – 250-Bed	91
Figure 12. Kitchen and Dining Hall Layout – 550-Bed	92
Figure I-1 Dayroom and Dining Area Corner Room	180
Figure I-2 Dayroom and Dining Area Interior Room	181
Figure I-3 Wheelchair Dimensions	197
Figure I-4 Table Design	198
Figure I-5 Telephone Design	199

LIST OF TABLES

	Page
Table 1. Distribution of Army Hospitals	20
Table 2. Average Costs Per Meal	22
Table 3. Correlation Analysis Between Direct Cost and Hospital Size	23
Table 4. System Configuration Summary	28
Table 5. Daily Meal Demand	31
Table 6. Daily Workload Basis -- 100-Bed Facility	36
Table 7. Cost comparison of Alternative Configurations -- 100-Bed MTF	38
Table 8. Daily Workload Basis -- 250-Bed Facility	39
Table 9. Cost Comparison of Alternative Configurations -- 250-Bed MTF	41
Table 10. Daily Workload Basis -- 550-Bed Facility	42
Table 11. Cost Comparison of Alternative Configurations -- 550-Bed MTF	44
Table 12. Inflation Rates	49
Table 13. Experimental Design for Each of the 10 Food Items	55
Table 14. Probability of F Exceeded for ANCOVA's by Menu Category	56
Table 15. Adjusted Mean Hedonic Ratings for Preparation Methods by Menu Category	58
Table 16. Mean Hedonic Rating for Reheating Device and Control by Menu Category	59
Table 17. Best Method or Groups from Range Tests	60
Table 18. Mean Hedonic Ratings by Preparation Method and by Menu Category	61

LIST OF TABLES (cont'd)

	Page
Table 19. Summary of Opinions of Hospital Food Service	64
Table 20. Evaluation of Temperature of Hot and Cold Food Items	66
Table 21. The Food Variable Contingency Coefficients in Relationship to the Rated Food Service	68
Table 22. Ranking of Meal Factors in Overall Consumer Acceptability – All Populations	69
Table 23. Ranking of Meal Factors in Overall Consumer Acceptability – Ward Patients	70
Table 24. Ranking of Meal Factors in Overall Consumer Acceptability – Dining Hall Patrons	71
Table 25. Systems Effectiveness Evaluation	B2
Table 26. Comparison of Alternatives	B3
Table 27. Projected Costs of the Frozen Ready Concept Compared Against the Current System	B5
Table 28. Comparison of Non-Military and Military Food Services	B6
Table A-1. Labor Costs – 100-Beds	100
Table A-2. Staffing Requirements – 100-Beds	101
Table A-3. Labor Costs – 250-Beds	102
Table A-4. Staffing Requirements – 250-Beds	103
Table A-5. Labor Costs – 550-Beds	104
Table A-6. Staffing Requirements – 550-Beds	105
Table B-1. Representative Menu – Conventional vs 80% Convenience	109
Table C-1. Area Equipment Costs – 100-Beds	112
Table C-2. Equipment List – 100-Beds	113

LIST OF TABLES (cont'd)

	Page
Table C-3. Area Equipment Costs – 250-Beds	122
Table C-4. Equipment List – 250-Beds	123
Table C-5. Area Equipment Costs – 550-Beds	134
Table C-6. Equipment List – 550-Beds	135
Table D-1. Functional Space Allotments – 100-Beds	146
Table D-2. Functional Space Allotments – 250-Beds	147
Table D-3. Functional Space Allotments – 550-Beds	148
Table D-4. Detailed Space Requirements	149
Table E-1. Energy Costs	152
Table F-1. Projected Cost – 100-Beds	154
Table F-2. Projected Cost – 250-Beds	155
Table F-3. Projected Cost – 550-Beds	156
Table G-1. Hospital Workloads – Summer 1977	159

A SYSTEMS ANALYSIS OF ALTERNATIVE FOOD CONCEPTS FOR NEW ARMY HOSPITALS

SECTION I

Executive Summary

Objectives

A systems analysis of the food service in Army Medical Treatment Facilities (MTF) is being conducted to determine the most cost-effective method for serving highly acceptable, nutritionally adequate meals to patients and other authorized personnel. The purpose of this study is to evaluate state-of-the-art concepts and to provide the Office of The Surgeon General (OTSG) with the best design options for use in the construction of new facilities.

Currently, hospital food services, and in particular, Army hospital food service divisions, are faced with increasing pressure to:

1. Stem the increases in labor costs and reduce current operating costs;
2. Reduce labor intensive operations, and increase overall productivity;
3. Provide more effective patient tray service; and
4. Assure energy effective operations.

The information provided in this report addresses these problem areas as they relate to funding decisions for construction of new hospital facilities by providing an evaluation of recent advances in feeding concepts, food service equipment, and food service technology; and a systems analysis of viable alternatives for military hospital food service operations including their relative cost and energy effectiveness. With sufficient and complete factual information concerning the different concepts, food service planners will be better able to make decisions and obtain funding for construction of more effective facilities.

The Army Hospital Food Service Mission

The primary mission of Army hospital food service¹ is to provide comprehensive nutritional care to patients and other personnel authorized to subsist in the hospital facilities. That is, the hospital food service must plan, produce, and serve nutritionally adequate meals which are therapeutically beneficial and best support the total medical

¹AR 40-2, "Army Medical Treatment Facilities, General Administration", Headquarters, Department of the Army, Washington, DC, July 1975.

program of the patients. In addition to responsibility for inpatient feeding, meals must also be provided for members of the hospital staff and other authorized personnel. Other important mission requirements include dietary counseling for patients, nutritional education, and applied research in the areas of medical nutrition. These activities involve instructing patients on restricted or modified diets to understand the purpose and importance of the prescribed diet to their medical well-being, and developing continuing educational programs in dietetics to support the discharged patients and promote good eating habits in the military community. In this report, the discussion focuses entirely on the food service mission, since the nutritional counseling and educational functions are virtually unaffected by the production system design and operation.

Another facet of Army hospitals which affects the food service mission is the requirement for a capability to double, or even triple, its food service capacity from a peacetime level in the event of an armed conflict or other emergency. The inefficiencies created by designing facilities that typically operate at a much reduced capacity must not significantly affect the sound, day-to-day, economic operation of hospital food service.

Methodology

In this report, four concepts of operation are defined and detailed as they could be effectively operated in a new Army facility. The basic difference in these alternative food service systems is the degree to which additional equipment is used to reduce manpower requirements-- their balance of capital and labor intensiveness. Each concept is analyzed and, based on data gained from experiments and from available literature, evaluated in terms of cost and effectiveness. The systems analysis then compares the concepts and indicates the preferred concepts for different sized facilities--100, 250, and 550 beds--by determining the state-of-the-art alternative which provides the highest quality foods at the lowest cost. The economic and benefit analyses are documented to demonstrate the advantage of the recommended system and to explain the basis for the recommendations.

Results and Conclusions

This section presents the results and conclusions that are derived from the detailed analysis contained in the remainder of this report.

1. The use of the proposed state-of-the-art concepts can provide substantial improvements in systems effectiveness over the existing operations. The most significant increase in effectiveness is provided by the ready foods concept. A concept under which foods are mass produced on the hospital premises where they are to be served, then frozen and stored for later use.

2. The marginal utility, the increase in the worth over the existing system, is greatest for the ready foods alternative, followed by the cook-chill, convenience, and conventional alternatives.

3. All of the alternative concepts can provide a more economical food service operation than does the current system, primarily through reducing labor requirements.

4. The disproportionate amount of direct food service costs attributable to personnel, and discrepancies in personnel utilization found in existing operations, suggests that a reexamination of staffing criteria in Army hospitals may be profitable.

5. Reductions in food service costs which can be obtained by use of the ready foods concept in Army hospitals is substantial, about 30%. Hospitals in the civilian sector have achieved similar savings without the advantages of much of the labor saving equipment considered in this analysis.

6. The projected savings in operating and annual costs should not be affected by inflation during the 1980-1990 time frame.

7. The ready foods system design is sufficiently flexible to support any of the other alternative concepts of operation. In addition, frozen items prepared at one facility can be shared by other hospitals. Thus, special items normally prepared in very small batches for a single hospital can be prepared in more economical large batches and distributed, when practical, to other facilities.

8. The use of equipment intensive concepts provides significant reductions in personnel costs. However, these savings in operating costs provided by the increased capital investment in equipment diminishes with the size of the facility. In small hospitals, the use of the ready food rather than conventional concept reduces labor costs by 47%. In medium and large facilities personnel reductions are less, while equipment cost increases are proportionately higher.

9. This evaluation of concepts is a detailed theoretical study. Even though the analysis is based on considerable experience and background data, it is essential that the operating characteristics of a selected alternative for the design of a specific hospital food service system be evaluated prior to an implementation decision. Using the techniques of the following systems analyses, the relative worth of each alternative in a particular hospital food service facility can be determined.

Recommendations

1. The ready foods system concept be adopted for all new construction of Army hospitals.

2. Current staffing policies and criteria be reevaluated by means of a work measurement to achieve economies in existing hospital food service operations.

3. Labor saving technology and equipment be provided to existing hospital food services, particularly to smaller facilities, to reduce the labor costs, thereby improving productivity and cost-effectiveness.

4. The ready foods concept should be evaluated in an operating hospital to validate the results of this analysis.

SECTION II

The Army Hospital Food Service System

Description

The Food service in Army hospitals is operated as a conventional, cook-serve system. Meals are prepared in the kitchen, loaded on to hot/cold food carts,² and delivered to the wards where the hot and cold portions are reassembled, beverages added, and completed trays delivered to the patients. In some facilities the insulated tray system is being used.³ Under the conventional concept of operations, the food items served in the dining hall to staff, ambulatory patients and guests are the same as that served on the ward.

Despite the similar concept of operations of Army facilities, differences in the workloads, the number of personnel, the categories of personnel, the availability and quality of food items, and geographical factors make it difficult to derive meaningful statistics and characteristics that are generally applicable to all food service operations. Operational analysis in several areas does indicate a number of significant parameters and trends which describe the Army Hospital Food Service System.

Analysis of Acceptability

Food service operations in five Army hospitals⁴ were surveyed to assess the overall food service acceptability and factors influencing consumer attitudes, as discussed in Section IV. The histograms, Figures 1, 2, and 3, present the food service ratings by consumer type (i.e., ward, ambulatory, and as a total group). These ratings indicate that these facilities provide more than an acceptable level of service, only about 6% of the customers responding with unacceptable ratings. In general, patients rate the food service higher than any other group of patrons. Furthermore, a significantly higher percentage of the ward patients as compared to the dining hall population, 24% and 13% respectively, rate the service as very good. Equivalent proportions of both groups rate the food service as good.

²Herz, M. L., et al., "Analysis of Alternative Patient Tray Delivery Concepts", Tech Report, NATICK/TR-7B/013, September, 1977, (AD A052 494).

³Food Service Division, Brooke Army Medical Center, "Staff Study on Food Service to Patients on Nursing Units", August, 1976.

⁴Brooke Army Medical Center, Eisenhower Medical Center, Letterman Army Medical Center, Moncrief Army Hospital and Silas B.Hays Army Hospital.

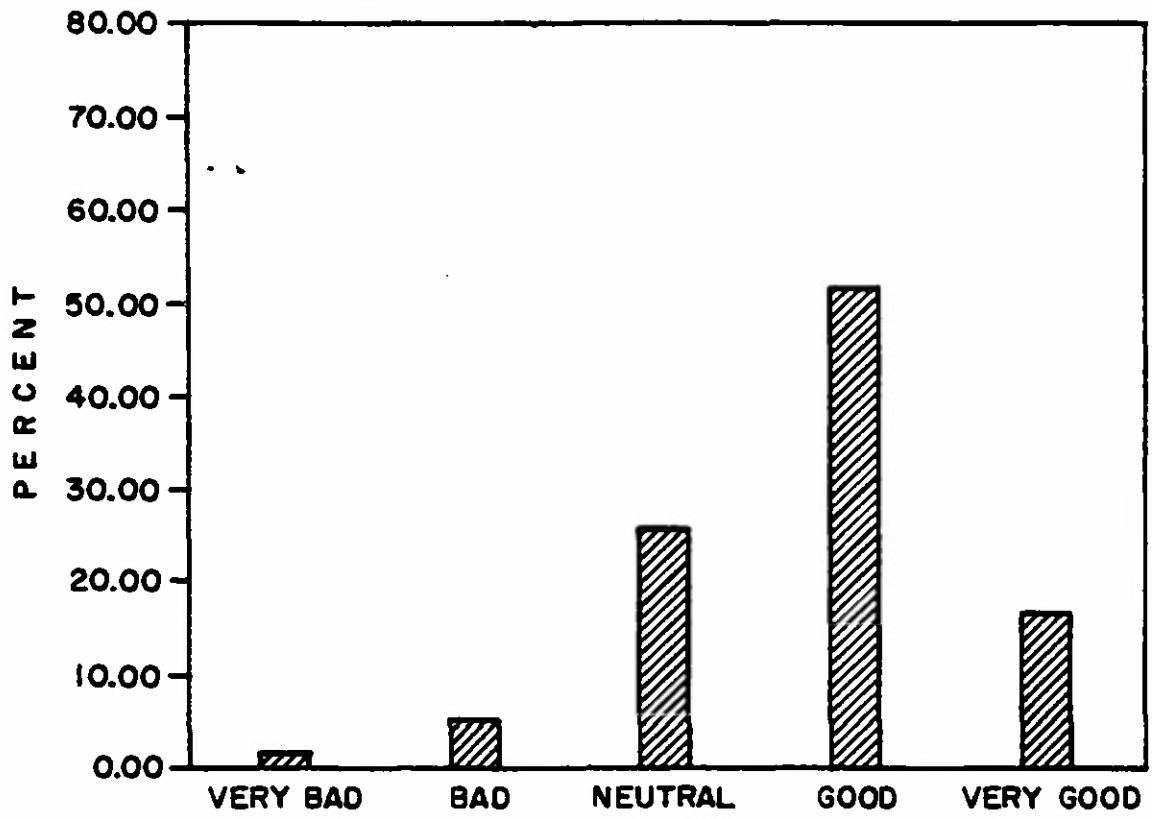

Figure 1. Distribution of Consumer Ratings – Overall Population

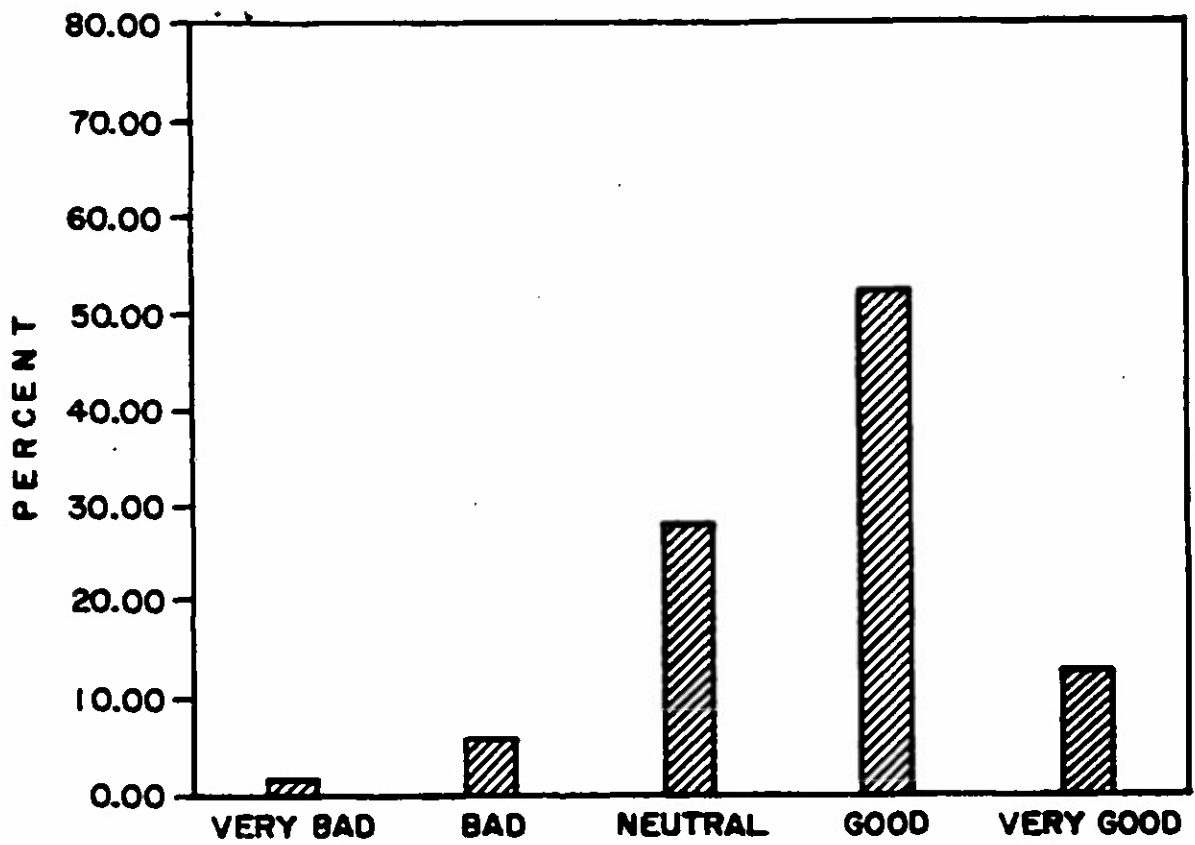

Figure 2. Distribution of Consumer Ratings – Staff and Ambulatory

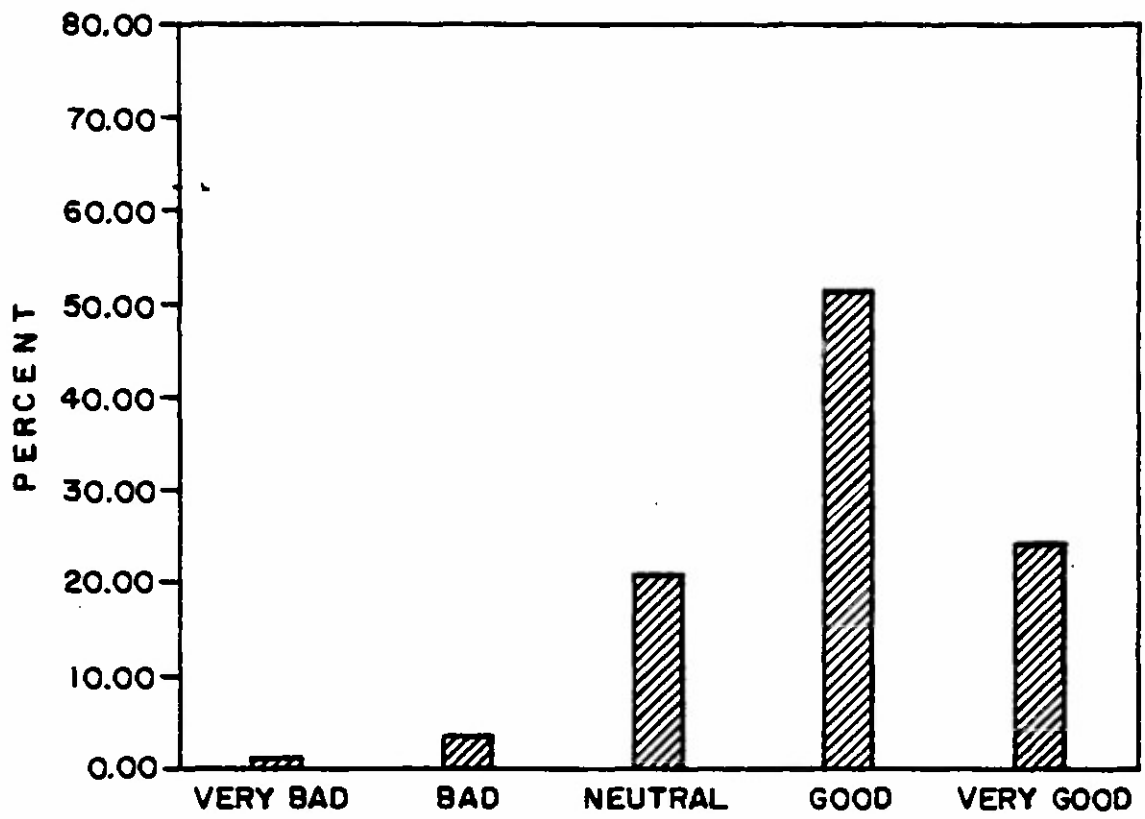

Figure 3. Distribution of Consumer Ratings – Ward Patients

Analysis of Operations

In addition to these measurements of consumer attitudes and acceptance, operational data was obtained from all Army hospitals in CONUS, Alaska, and Hawaii by questionnaire. This questionnaire provided a broad range of data on the hospital food service environment and their operational characteristics, and a description of the physical facilities. The major quantifiable parameters included (1) the workload distributions, (2) general measures of productivity, (3) task distribution and allocation of labor, (4) direct costs, and (5) the distribution of cost elements. These data are contained in Appendix G and provide baseline data describing the overall Army Hospital Food Service System.

The data are evaluated by considering the hospitals in four groups: small facilities with daily census ranging up to 175 patients (i.e., 100 bed hospitals); medium facilities with censuses which range from 176 to 325 patients (250 bed hospitals); large facilities in the range above 325 patients (550 bed hospitals); and the total group of 33 responding facilities. The distribution of censuses and workloads is given in Table 1 for each group. The largest group is composed of the small facilities ($n = 21$), thus the results for the total group will be heavily weighted by the effects of these facilities. The large standard deviation for the patient census of these different groups indicates that census cannot be used to typify the hospital systems. The workload, or the total number of daily meals served, increases with hospital size with a corresponding increase in the percentage of patient meals from 41.5% for 100-bed hospitals to 53.5% for 550-bed hospitals. As with the census data, large standard deviations are associated with the number of meals served for each group of hospital sizes.

Productivity, or the number of man-hours per meal, is derived by three different methods and ranges from 0.40 to 0.45 man-hours per meal. However, when the data is partitioned by hospital groups, the man-hour data shows meaningful differences between different sized facilities with significantly lower productivity for the small hospitals than for either of the other two groups of larger facilities. In addition, it is estimated that inpatient related food service duties, except nutritional counseling, require almost 60% of the labor resources, although patients comprise only 50% of the workload. This emphasizes the labor intensiveness of these duties. The basic food service tasks, ranked in terms of decreasing manpower utilization, are food preparation (i.e., storeroom activities, baking, meat cutting, and food production), followed by patient tray delivery operations (tray assembly, cart delivery), by cafeteria and sanitation activities, and then by clinical and nutritional duties.

The direct costs in hospital food service are labor, food, supply, and contract costs. Labor costs constitute seventy percent of the direct cost of the Army Hospital Food Service System. The analysis of costs is simplified by normalization of the cost elements on a per-meal basis. Then, Analysis of Variance (ANOVA) and range tests can be used to differentiate cost elements across hospital sizes. A correlation analysis of cost elements indicates significant relationships within individual hospital groups and provides information

TABLE 1
DISTRIBUTION OF ARMY HOSPITALS

Factors	Hospital Size			Total
	100--Bed	250--Bed	550--Bed	
Sample Size	21	7	5	33
Census Range	17-173	176-300	440-647	17-647
Rations - Daily Patient Census	69.9	240.0	473.8	164.0
Standard Deviation	53.3	28.7	128.5	158.7
Workloads				
Mean No. Daily Meals	464.9 (268.2)*	1220.4 (286.8)	1866.8 (777.6)	837.6 (651.7)
Mean No. Patient Meals	193.1 (149.3)	665.3 (115.2)	999.0 (611.9)	415.4 (403.1)
Mean No. Non-Patient Meals	271.8 (141.1)	555.1 (186.7)	867.8 (229.0)	422.2 (274.4)
Percent of Special Diets	32.2 (11.9)	25.4 (10.0)	29.8 (2.4)	31.1 (10.9)
Percent Patient Meals	41.5	54.5	53.5	49.6

*Standard Deviation in parentheses.

on trends in cost with size, Table 2. Only 28 of the 33 hospitals can be considered in the cost analysis, since five hospitals have total direct costs per meal outside the reasonable bounds of confidence ($p > 0.99$). An ANOVA of the data on Table 2 shows that the labor and total direct costs per meal for 100-bed hospitals (\$3.04 and \$4.29), respectively, are significantly greater than similar costs in the large hospitals (\$2.47 and \$3.65).

The correlation analysis indicates little or no relation between census and direct cost (except with the 550 bed hospitals where the sample size, 4, is too small for statistically meaningful results). Although cost differences exist between large and small facilities, no linear predictive model could be derived to explain these differences, i.e., no better estimate can be determined for any of the cost elements than mean cost values given in Table 2 for a particular hospital size. A relatively low correlation coefficient value ($r = 0.342$) for this data, partitioned into cells in Table 3, also suggests a very weak linear relationship between hospital size and cost.

Finally, the possible cost advantage of in-house preparation over purchase of finished food items for the baking and meat-cutting activities is evaluated. Given the high variation in costs relative to the mean costs, no significant differences were noted between in-house production and procurement of these items. Only a small number of hospitals in this sample have baking and meat cutting done off site, reducing the sensitivity of the test which compares these differences.

Conclusions

(1) Productivity ranges between 0.40 and 0.45 man hours per meal in existing facilities and is higher in the larger hospitals than for the small hospitals.

(2) The largest proportion of labor is utilized in food production followed by duties related to patient tray service, then sanitation and cafeteria activities, and finally by clinical dietetic functions.

(3) Seventy percent of the direct costs for food service are for labor, a relatively large proportion compared to civilian facilities which average only about 47% labor costs.⁵

(4) The larger hospitals (i.e., 250 and 550 beds) have lesser total and labor costs per meal than the smaller hospitals. However, no significant relationship can be found between the hospital census and cost.

(5) The average costs for meat and bakery items are \$0.52 and \$0.12, respectively. The cost benefit of on-site baking and meat cutting activities are not apparent from an analysis of the data from existing facilities.

⁵American Hospital Association, Hospital Administration Services Report, National Group 190, 1st Quarter 1976, and National Group 940 1st quarter 1976 and 1st half 1977.

TABLE 2

AVERAGE COSTS PER MEAL

Direct Cost	Hospital Size			Total (n = 28)
	100-Bed (n = 18)	250-Bed (n = 6)	550-Bed (n = 4)	
Labor	\$3.04*	\$2.47	\$2.47	\$2.83
Food	1.11	1.09	1.08	1.10
Supply	0.13	0.08	0.10	0.12
Other and Contract	0.01	0.01	0.00	0.01
Total	4.29*	3.65	3.65	4.06

*Value is significantly different from the 250- and 500-bed hospitals at the $p = 0.02$ level.

TABLE 3
CORRELATION ANALYSIS BETWEEN
DIRECT COST AND HOSPITAL SIZE

Hospital Size	Direct Cost Per Meal Groups				
	\$3.00— \$3.50	\$3.51— \$4.00	\$4.01— \$4.50	\$4.51— \$5.00	\$5.01— \$5.50
100—Bed		6	4	3	2
205—Bed	2	4	3		
550—Bed	1	2	1		

$r = 0.342$

SECTION III

Economic Analysis of Alternative Systems Concepts

Alternative System Concepts

Studies of the state-of-the-art have delineated four major food service production concepts:

A. Conventional Concept

In a purely conventional food production system, all menu items are prepared from their basic ingredients, assembled and finished in the system. Essentially, most of the cooking and preparation is accomplished on the day the food is to be served. Realistically, however, a purely conventional system does not actually exist, since many items such as bread, ice cream, orange juice, canned and frozen vegetables can be purchased at a lower cost than they can be produced from recipes without significant loss in quality. Thus, a conventional food system can be considered as one which utilizes a low percentage of advance preparation or partially prepared food items, and relies primarily on full preparation from recipes.

B. Convenience Foods Concept

Convenience foods refers to prepared menu items which can be readied for service without highly skilled cooking labor. A total convenience food system, thus, makes almost exclusive use of off-site prepared foods. Pre-cooked frozen foods are purchased in either bulk or individual portions, and stored until required for service. The only labor required before service is portioning and reheating, and with certain items, even these tasks can be eliminated. For example, pre-cut salad greens do not require tempering or heating, and individual fruit tarts do not require portioning. Items that do not lend themselves to freezing, such as salads and sandwiches, are purchased in a refrigerated state and utilized within a short period.

The variety of convenience food items and the quality of such products are increasing, so that many of the foods on a typical hospital menu are currently available on the market. Unfortunately, many items do not lend themselves to the convenience foods concept. Meats without gravy, steaks, chops, grilled sandwiches, and several breakfast items must still be prepared. In order for a convenience food system to be practical, it should be feasible to obtain 70 to 80 percent of all required products commercially, requiring only limited on-site production facilities.

C. Cook and Chill Concept

The cook and chill system entails on-site food preparation, followed by rapid chilling, tray assembly, storage of the finished items. The majority of foods are generally prepared

for service about three days in advance. Preplated foods are then heated, as needed, on each ward just prior to serving. Foods served in the dining hall may be prepared in a conventional manner and/or by heating chilled bulk.

D. Ready Foods Concept

Ready foods is a term used for foods that are mass-produced in the system, then frozen and stored in a form that requires only reheating to be ready for service. This concept can be generally described as in-house production of convenience foods.

Functional Areas

A generalized functional chart for hospital food service is shown in Figure 4. The alternative concepts, despite their obvious differences, are for the most part functionally equivalent. That is, all hospital food service production systems are composed for the most part of similar subsystems which function to produce prepared meals. These functional areas do differ in some respects in systems designed for alternative concepts. Differences are found in the preparation areas and refrigerated storage areas. The least equipment intensive concept, the convenience concept, does not require an ingredient room, a bakery, a meat shop, or a portioning and packaging area, and, in addition, has reduced space requirements for bulk raw food storage, vegetable preparation, and hot food preparation. However, this concept, like the other advance preparation concepts, needs additional low temperature refrigeration. The cook-chill and the ready foods concepts utilize the same size areas as a conventionally designed system, but require, in addition, portioning and packaging equipment, rapid chill or freeze equipment, and the refrigerated storage space to support a prepared food inventory.

Cost Analysis

The first step in the evaluation of these different alternative concepts of operation involves the analysis of the costs of operating a standard or "typical" Army Hospital Food Service under each particular concept. To do this an Army MTF food service system is designed for each of the four concepts of operation (i.e., conventional, convenience, cook-chill, ready foods) to operate within the guidelines and regulations set forth within the appropriate hospital food service manuals. The result is a general description of each concept as it would be designed to operate in an efficient manner (i.e., cost effectively and with maximum productivity) in an Army MTF (Table 4). Since the food service in Army hospitals is currently operating under a conventional concept, this concept, as redesigned to incorporate recent state-of-the-art improvements in technology, will for the purposes of this analysis be called "the improved conventional system". The description provides the necessary data to allow a comparison of the basic concepts by considering the critical cost components. In short, the overall design of each system is defined by three basic elements:

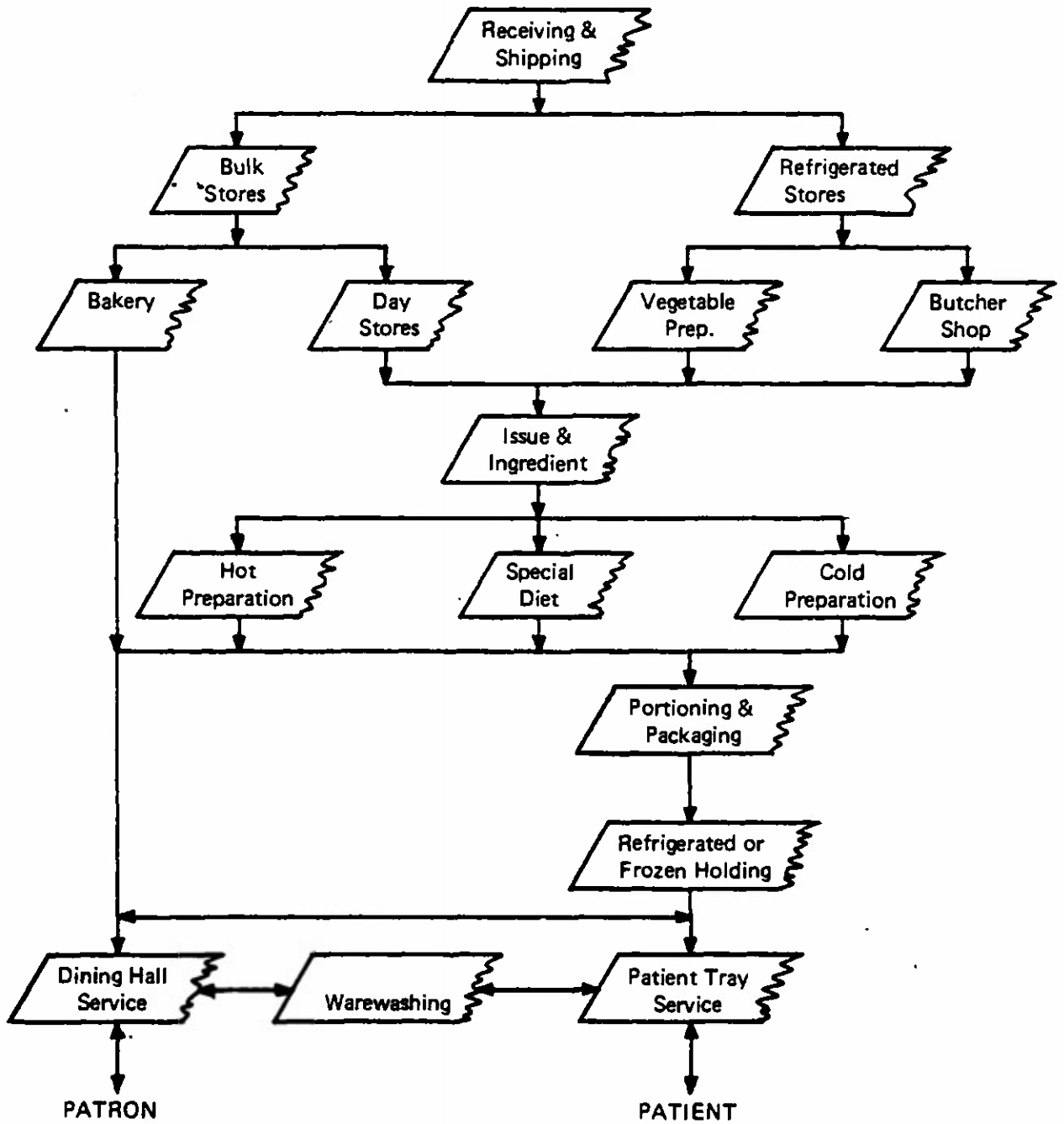

Figure 4. Hospital Food Service Functional Flow

TABLE 4

SYSTEM CONFIGURATION SUMMARY

SYSTEM	PREPARATION	PACKAGING	HOLDING	PLATING OR SERVICE	END HEATING
Improved Conventional (Patient)	All fresh preparation on day of service	None	Mobile Hot and Cold Storage Boxes.	Plate hot on Tray line.	None
Improved Conventional (Dining Hall)	Utilize patient menu items as feasible Staggered Batches — serve as soon after cooking as feasible. Fresh production of eggs, grilled meats, fried items and delicatessen sandwich board.	Bulk pans with lids	Hot or Cold Pass-thru from kitchen line.	Plate hot on Serving line.	None
Convenience (Patient)	Purchase all items in convenience form. On-site production to include: Poached and fried eggs, cooked cereals, deep fried and grilled foods, some fresh raw salads, salad accompaniments and garnishes, sandwiches, pasta, noodles, rice, dehydrated vegetable and potato items, canned or dehydrated soups, canned, dehydrated or frozen vegetables, brown and serve breads, rolls, and desserts. Special diet and nourishment items such as milk shakes, egg noggs, tube feedings. Prepare and freeze minimum special diet items which cannot be purchased, or accept some menu restrictions.	Purchase in bulk pans. On-site production of limited special diets. Individually portioned into bags: A. Boil in bag B. Oven bag Commercial special diet items will be procured in smaller portion pack quantities.	Frozen 14-day on-site storage of commercial finished product. Tempered in thawing refrigerator 24 hours in advance	Plate cold on serving line day of service.	Tray cart type rethermalization cart or equivalent.
Convenience (Dining Hall)	Cook and end-heat dining hall foods as required. End-heat all convenience bulk pans in double door convection ovens — or steamer or kettles Fresh preparation of eggs, grilled items, fried items and delicatessen sandwich board.	All bulk pans.	Frozen with 7- to 14-day on-site holding.	Plate hot on serving line.	End heat in dining hall servery (convection oven).

TABLE 4

SYSTEM CONFIGURATION SUMMARY (cont'd)

SYSTEM	PREPARATION	PACKAGING	HOLDING	PLATING OR SERVICE	END HEATING
Bulk Cook-Chill (Patient)	Prepare general diets (entree and soup) one to three days in advance. Five-day production for seven days. Produce four items daily per meal - Friday will produce Monday's meals. Prepare special diet end low volume batches in minimum of 25 portions and freeze. (Batch size varies according to demand.) Fresh daily preparation of raw salads, cooked cereals, breakfast eggs, liquid special diets, nourishments, paste, starches, frozen vegetables, brown and serve products.	Bulk pan with lid. Pen hot and place in pre-cooler. Vacuum packaged in portion pack bags. Some product may be IOF (Individual Quick Frozen) and bagged in bulk quantities.	Holding refrigerator in bulk pans or containers. Some Frozen end tempered. (Pull from inventory night before service.)	Plate cold on trayline day of service.	Tray cart type rethermalization system or equivalent on patient floor. (Ambulatory patients could be served at servery line from hot/cold pass-thru. Portion pack pouches could be thermalized in kitchen end maintained in heated pass-thru cabinet.)
Bulk Cook-Chill (Dining Hall)	Prepare with general diets one to three days in advance of service. Grilled and fried items, breakfast eggs, and delicatessen sandwiches prepared on demand.	Bulk pan or container with lid.	Refrigerated.	Dining hall servery.	Heat in dining hall servery in convection oven or other reheat device.
Bulk Ready Foods (Patient)	Large batches should be prepared for one menu occurrence with consideration of optimum batch size. Medium and small quantity items will be produced on 30- to 60-day inventory basis. Largest batches produced one week ahead. (This will cover 70% of consumption.) Small batch items (30% of daily consumption) will be held for 30-day average dwell in freezer. (Net total freezer space requirements: 15 days x all items.) Fresh daily includes raw salad, cooked cereals, breakfast eggs, liquid special diets, nourishments, pasta, starches, frozen vegetables, brown and serve products.	Bulk pans with air-tight lid and shrink film overwrap. IOF end pack specific products (largely for special diets)HOLDING	Frozen Tempered in thawing refrigerator in advance.	Plate cold on patient trayline.	Tray cart type rethermalization system or equivalent.
Bulk Ready Food (Dining Hall)	End-heat bulk ready food and serve as in convenience food system. Fresh grill items including eggs, grilled meats, fried items and delicatessen sandwich board.	Same as convenience.	Same as convenience.	Plate hot on serving line.	Reheat in dining hall servery (convection oven)

- (1) The concept of operation,
- (2) The regulations governing hospital food service, and
- (3) The workload.

These elements can then be integrated with a number of operating assumptions which then describe an efficient mode of food production and service, and the proper level of dietary counseling.

The most critical element of a cost analysis is the accurate estimation of relevant costs. It is also vital that this information be provided on an incremental basis so that the analysis considers and analyzes only the differences in costs between the systems and ignores hospital costs that remain unaffected by the food service system. The costs, then, that must be considered in a comparative analysis of hospital food service concepts are:

- (1) Food service labor costs,
- (2) Food costs,
- (3) Construction (space) costs for food service,
- (4) Food service equipment costs,
- (5) Energy costs related to the operation of only the food service, and
- (6) Supply costs.

As was mentioned earlier, this analysis of concepts considered a range of different sized facilities -- 100, 250, and 550 beds. For each facility a separate cost analysis is carried out under a general set of assumptions which describes an efficient operation for each particular concept of operation and workload. In addition, the particular assumptions which must be made for each size MTF to derive a cost are documented and provided, in effect, a working food service system illustrative of a theoretical concept.

Assumptions

The workloads and other assumptions basic to the economic analysis made in performing this analysis follow:

1. Service demands

Service demands (Table 5) have been established as typical for food service in Army facilities of 100, 250, and 550 beds. These workloads were determined by a random sampling of those facilities which during May 1977 had approximately the desired census.

TABLE 5
DAILY MEAL DEMAND

	100-Bed		250-Bed		550-Bed	
Inpatient Ward Meals	195		427		550	
Special Diets	<u>45</u>	240	175	602	<u>675</u>	1,225
Ambulatory Inpatient						
Meals in Dining Hall	45		110		275	
Staff and Visitors Dining Hall	<u>445</u>	490	<u>583</u>	693	<u>950</u>	1,225
Total Ward and Dining Hall		730		1,295		2,450

The noon meal service in the dining hall constitutes 50% of its daily volume, while breakfast and dinner service each contribute 25%.

2. Inpatient Menu

The inpatient menu format is typical of that currently used in Army MTF. The format can be described as below:

Breakfast:

1 Juice or 1 Fruit

1 Hot Cereal	4 Cold Cereals
2 Egg Varieties	1 Meat
Toast	Donut or Sweet Roll
	Beverages

Lunch:

Soup of the Day
2 Hot Entrees
1 Salad Cold Plate or 1 Sandwich Cold Plate
1 Starch
2 Hot Vegetables (one green daily)
1 Fruit Salad 1 Vegetable Salad
Bread or Roll with Butter
1 Baked Dessert 1 Plain Fruit Dessert
1 Gelatin Dessert 1 Ice Cream
Beverages

Dinner:

2 Hot Entrees
1 Salad Cold Plate or 1 Sandwich Cold Plate
1 Starch
2 Hot Vegetables (one green daily)
1 Salad
Bread or Roll with Butter
1 Baked Dessert 1 Plain Fruit Dessert
1 Pudding Beverages

3. Menu Format: Dining Hall

The menu format for the hospital dining halls is based on the one offered to the hospital's inpatients. In addition, it is supplemented by fresh sandwiches and limited hot grilled items, such as hamburgers, cheeseburgers, hot dogs, and grilled cheese sandwiches. A full selection of hot and cold beverages, carbonated and noncarbonated; and soft serve ice cream are also provided.

4. Meal Periods

A. For dining hall service:

Breakfast	6:30 AM – 8:30 AM
Lunch	11:00 AM – 1:30 PM
Dinner	4:00 PM – 7:00 PM

b. For inpatient service:

Breakfast	7:00 AM – 8:30 AM
Lunch	11:00 AM – 1:30 PM
Dinner	4:30 PM – 6:00 PM

5. Ward Patient Meal Service

a. Improved Conventional System. Employs a conventional patient tray assembly and insulated tray system to deliver hot meals to inpatients.

b. Convenience System. Employs a tray reheating cart or its equivalent. Patient meals are assembled from thawed bulk pans in the kitchen, placed on trays, and transported in chilled form to the ward where they are reheated without tray disassembly in the special cart.

c. Cook-Chill System. Also requires inpatient trays to be delivered chilled to the ward where they will be reheated in a cart just prior to service to the patient.

d. Ready Foods System. Requires inpatient trays to be delivered chilled to the ward where they are reheated prior to service.

6. Ambulatory Patient Meal Service

Wherever feasible, ambulatory patients are encouraged to take their meals in the dining hall. Those ambulatory patients on restricted/modified diets are served their prescribed meal tray from a service cart.

7. Bakery Limitations

a. A 550-bed hospital bakery prepares all baked menu items from scratch using standardized recipes/formulas. Bread and hamburger/hot dog rolls are purchased off-premises.

b. A 250-bed hospital prepares most baked menu items from purchased mixes. Pies and rolls are purchased partially baked and finished on premises. Bread, sweet rolls and hamburger/hot dog rolls are purchased off-premises.

c. A 100-bed hospital purchases almost all convenience bakery products, although simple cakes and cookies are produced from purchased mixes. Pies and rolls are purchased baked and finished on site. Bread, sweet rolls, and hamburger/hot dog rolls are purchased off-premises.

8. Butcher Shop Limitations

a. The 550-bed hospitals are designed with a full butcher shop and are staffed to fabricate steaks, chops, roasts, ground meats and hand diced meats from whole carcasses or, more often, from partial cuts.

b. The 250-bed hospitals use modified butcher shops and are staffed to process primal cuts, or to fabricate ground meats and hand diced meats.

c. The 100-bed hospitals have no butcher shop, since all meats are purchased ready for cooking off-premises.

9. Ingredient Room

For the purpose of this analysis, the ingredient room functions are to scale (weigh) and prepackage ingredients for the cooking personnel. Vegetables and fruits are washed and peeled in a separate vegetable preparation area.

10. Bulk Storage

The bulk storage area is designed to accommodate supplies for at least fifteen days.

11. Dining Hall Area

The dining area reflects the service demands of the noon meal. This area provides space for the specified number of patrons assuming a 2.5-hour meal period and 16 ft² of space for each diner.

12. Labor Requirements and Costs

a. Staffing estimates for the various systems are established through workload analysis of the functions/job to be performed rather than from staffing manuals (Appendix A). It is felt that all the currently operating MTF food service systems deviate from today's staffing norms as found in the civilian sector, and that a true and more comparable staffing complement can be achieved by the analytical study of the jobs to be performed and the necessary hours of operations. Thus, each system is staffed for a high level of productivity by determining the necessary tasks and schedule assuring that an adequately skilled food service staff member would be scheduled for duty when necessary. This requires that, in some cases, one task or duty is performed by staff from different job categories. For example, food service workers are required to support patient tray service in certain instances.

The cost of labor for each system was calculated based on the Composite Standard Rates for Military Personnel, on the general schedule, and on a median wage grade scale determined for CONUS MTF for wage grade employees.

b. Qualified food service staff are assigned the duties of reheating of chilled trays for patient meals. It is felt that the importance of properly operating the state-of-the-art tray delivery system warrants this assignment.

c. Nursing Service Staff pass the patient meal trays to ward patients once the hot food has been heated properly.

d. Dining Hall workload is equivalent for all systems and dining hall employees do not perform production duties in the main kitchen. In advance preparation systems, the dining hall employees take the frozen or chilled foods from a cold pass-through refrigerator from the kitchen and reheat it in the service area convection ovens.

13. Food Costs

The cost of food is calculated using the 1977 average meal cost for Army MTF as a basis (Appendix G). The cost of convenience foods has been found for this level of operation to be 50% greater than on-site prepared foods (Appendix B). The reduction of waste under the frozen ready concept indicates that at least a 2% reduction in food costs can be achieved.

14. Equipment Costs

Equipment is selected for each concept assuming that the menu would not be limited. The ability of the food service to sustain an emergency expansion of the MTF, a vital factor, is supported by this additional equipment. Thus, under all the concept developments, the equipment cost may be considered relatively high in comparison to

those that are found in many civilian activities. However, this allows the military the flexibility to react to situations not in any way common to civilian facilities. The selected equipment is commercially available, is priced in 1977 dollars, and is similar to that found currently in military and civilian facilities. Detailed equipment lists are given in Appendix C.

In terms of these costs, the improved conventional system will be seen to be less expensive than most advanced preparation concepts. Savings due to reduced production equipment resulting from off-site production or from economies of scale for in-house production will be offset by the necessity of larger amounts of preparation, refrigeration, and freezer equipment. Additionally, the newer cart delivery systems used with advanced preparation methods are capital intensive. These advanced preparation concepts were developed to take advantage of an equipment - labor tradeoff that was felt to exist, and would, at first glance, seem to reduce the cost of labor intensive hospital food service operations.

15. Construction Costs

Construction costs for all areas and all hospital sizes have been established at an average of \$85.00 per square foot.⁶ Areas are calculated from the equipment space requirements, and from the storage requirements as dictated by delivery/inventory levels and by current procurement procedures. Appendix D details the space requirements for food services in the different type facilities.

The different concept designs again reflect the impact of off-site preparation and advanced preparation. The convenience systems require the least space as the increase in refrigeration is easily offset by the reduction in areas associated with food preparation. The other advanced preparation systems need slightly less preparation area in comparison to the conventionally designed system but significantly more space for packaging and cold or frozen storage.

16. Energy Costs

The energy in kWh needed to operate each facility under each concept was calculated from standard levels of equipment utilization which would support the workload requirement (Appendix E). The cost of energy is \$0.03 per kWh based on nationwide data.⁷

⁶AR 415-17, "Empirical Cost Estimates for Military Construction and Cost Adjustment Factors," HQ, Department of the Army, Wash, DC, 9 Aug 1976.

⁷Office of Commercial/Industrial Sales, Boston Edison Co., Summer, 1977.

17. Supplies and Other Costs

Supplies and other items in MTF have cost \$0.11 per meal (or about \$0.33 per ration).⁵ This value is used to determine the projected operating costs in this analysis.

The 100-Bed Facility

Small facilities are defined as hospitals operating with 100 inpatients. These hospitals provide general medical and dental care and treatment to eligible personnel, but, as defined for this analysis, will not serve as a specialized treatment or teaching facility. They provide primary medical care to inpatients, support general outpatient clinics, and where necessary, refer patients for admission to larger MEDDAC or MEDCEN for more specialized care.

These facilities are acute care facilities (i.e., patient stays of about 5 days) with limited equipment and personnel. Treatment of most common illnesses and injuries, preliminary diagnosis of specialized cases, and health screening are their major responsibilities. A reflection of the type of patients and illnesses is seen in the operating parameters (i.e., workload distribution - Table 6) of the facility. To reflect the large number of Army facilities operating at less than 100 beds, (i.e., facilities which generally serve a large proportion of their meals to staff) and to make the analysis more easily applicable in their cases, the number of non-patient meals was set at 60%.

TABLE 6

DAILY WORKLOAD BASIS - 100-BED FACILITY

Inpatient Meals		% Patient Meals
Ward	240 (33%)	84
Dining Hall	45 (6)	16
Total	295 (39%)	100
Non-Patient Meals	445 (61)	
Total Meals	730 (100)	
Special Diet Meals	45	16

⁵HSC Progress Summary, Ft. Sam Houston, TX, 3rd Quarter 1977.

The percentage of special diet meals is relatively low at 16% of the patient population reflecting the relatively younger patient population and the large population of acute illness treated in these facilities which do not require modified diets (i.e., orthopedic, minor surgical, and respiratory infection patients).

Cost Elements

Equipment Requirements

The equipment necessary to operate the food service divisions of a small MTF is listed in Appendix C. The cost for equipment is summarized by area in Table C-1. The costs are greatest for the in-house advance preparation methods, with their additional requirements for refrigeration and galley equipment more than offsetting savings in the preparation or tray assembly areas. The increase is 3% for a convenience design, 24% for cook-chill, and 34% for ready foods over a conventional design.

Space Requirements

More space for the refrigeration without any offsetting decrease in preparation areas cause an increase in space (about 6%) requirements for on-site advanced preparation as compared to the conventionally designed system. The convenience concept allows overall for a small reduction (9%) in space. The requirement in each area is listed in Table D-1.

Labor Costs

The reduction in personnel costs is directly related to the degree to which preparation is separated from service. As can be seen in Table A-1, advanced preparation systems reduce total personnel costs (i.e., skill levels and cost/FTE).

Energy Requirements

As can be seen in Table E-1, the reduced need for energy for food preparation under the convenience concept makes this system the most energy effective in this size facility. The on-site advanced preparation concepts, as anticipated, increase energy significantly. Despite the additional equipment for reheating, storage, and rapid cooling, the increase is less than 60%.

Cost Analysis

Analysis of Table 7 indicates that for the 100-bed size MTF the Ready Foods Concept will provide meals at the lowest annual cost. The convenience concept will, in fact, tend to increase costs over the conventionally operated system since the increased cost of food is not balanced by savings in other areas. The significant increases in capital costs necessitated by the more equipment intensive advance preparation methods becomes insignificant when considered against the substantial savings in operating costs (41%).

TABLE 7
COST COMPARISON OF ALTERNATIVE CONFIGURATIONS -- 100-BED MTF

	Existing System	Improved Conventional	Convenience	Cook--Chill	Ready Foods
Capital Costs					
Equipment	\$270,045	\$270,045	\$271,135	\$326,660	\$353,460
Construction	503,200	503,200	458,150	520,200	547,825
Total	773,245	773,245	729,285	846,860	901,285
Differential Capital Cost ¹ (Decreased)	-	-	(43,960)	73,615	128,040
Operating Costs					
Labor ²	833,989	447,971	324,718	404,074	385,556
Food	311,747	301,089	452,965	301,089	295,067
Supplies ³	26,645	31,014	29,310	29,310	29,310
Energy ⁴	-	3,683	3,574	4,622	5,446
Total	\$1,172,380	\$780,074	\$806,993	\$734,473	\$709,933
Cost/Meal	\$4.40	\$2.93	\$3.03	\$2.76	\$2.66
Differential Operating Cost ^{1,4} (Decrease)	-	-	26,919	(45,601)	(70,141)
Differential Operating Cost ^{4,6} (Decrease)	-	(392,306)	(365,387)	(437,907)	(462,447)
Annual Costs ⁵	1,268,302	877,527	900,728	844,383	827,725
Cost/Meal	\$4.76	\$3.29	\$3.38	\$3.17	\$3.11
Differential Annual Cost ¹ (Decrease)	-	-	23,201	(33,144)	(49,802)
Differential Annual Cost ⁶ (Decrease)	-	(390,775)	(367,574)	(423,919)	(440,577)

¹ Improved Conventional System as base.

² Including fringe benefits.

³ Includes maintenance cost of Insulated Tray System (Conventional System only).

⁴ Energy costs not included in operating costs; provided for comparisons only.

⁵ Annualized cost of labor, food, equipment, construction energy and supplies assuming 10-year benefit life for equipment and 25-year beneficial life for construction.

⁶ Current operations as base.

The 250-Bed Facility

Hospitals operating with 250 patients are considered in this analysis as medium size MTF. More specialized treatment is provided by these facilities than in the case of the small MTF, and for this reason, these facilities have available the equipment and staff to provide treatment in basic medical or surgical specialties and subspecialties. If more extensive care is necessary, patients are referred to the large facilities for treatment. The medium size facilities treat more chronic illnesses and have patients with longer stays (i.e., about 7 days) than the small MTF. Its operating parameters (Table 8) are indicative of this character. Relative to the smaller facilities, the proportion of special diet meals and ambulatory patients has been increased to reflect the typical workload distribution of similarly sized Army MTF and the previously mentioned effect of patient tray and staffing ratios. The number of special diet meals, and the proportion of patient meals have been increased, and the number of ambulatory meals held constant in comparison to smaller facilities.

TABLE 8
DAILY WORKLOAD BASIS - 250-BED FACILITY

Inpatient Meals			% Patient Meals
Ward	602 (45%)		85
Dining Hall	<u>110 (8)</u>		15
Total		712 (55%)	100
Non-Patient Meals		583 (45)	
Total Meals		<u>1295 (100)</u>	
Patient Special Diet Meals		175	25

Cost Elements

Equipment Requirements

The advance preparation concepts require more equipment than the improved conventional system (Table C-3). The convenience, cook-chill, and ready foods systems have increasingly greater refrigeration costs (12, 37, and 50% respectively) which easily offset economies in other areas.

Space Requirements

As can be seen in Table D-2, compared to the conventionally designed system the convenience design results in a 10% reduction in space, and the ready foods and the cook-chill in a 12 and 7% increase, respectively.

Labor Costs

Although the advance preparation methods did again significantly reduce labor costs (Table A-3) in comparison to the conventionally designed concept (i.e., 13-21%), increases in the proportion of responsible storeroom personnel and skilled diet aids raised the skill level and, thereby, the individual cost of each employee for the advanced concepts. As will be discussed later in this report, the overall reduction in labor costs compared to food service systems currently in operation is about 40%.

Energy Utilization

Similar to the smaller facilities, the advance preparation methods with the requirements to cook, cool, store at reduced temperature, and then reheat foods used more energy relative to the improved conventional concept as shown in Table E-1.

Cost Analysis

The ready foods concept as applied to a 250-bed MTF is the most cost effective system (Table 9) while a convenience system will significantly increase operating costs. In this last case, the savings in capital expenditure is easily offset by increased operating costs. The additional cost of the other advanced preparation concepts is offset by reduced operating expenses.

The 550-Bed Facility

The large facilities are defined as specialized medical treatment facilities which serve as referral hospitals and supply necessary laboratory support for the smaller MEDDAC. Their operating level in this analysis is considered to be 550 patients. Often these facilities have a teaching function, but this study considers only their medical responsibilities which include general and specialized medical and dental care and treatment, outpatient, and inpatient. In keeping with their specialized and referral functions, the inpatient character involves more chronic illnesses including many long term psychiatric patients who are ambulatory. This is reflected in the workload assumptions (Table 10) with increased ambulatory loads in the dining hall, increased numbers of special diets, and increased proportion of patient meals⁹ as compared to the smaller facilities.

⁹ Acute illnesses require more medical procedures than long term care, therefore, these facilities can be assumed to have a lower overall staff to patient ratio. HSC Progress Summary, Ft. Sam Houston, TX, 4th Quarter 1975.

TABLE 9
COST COMPARISON OF ALTERNATIVE CONFIGURATIONS -- 250--BED MTF

	Existing System	Improved Conventional	Convenience	Cook--Chill	Ready Foods
Capital Costs					
Equipment	\$434,057	\$434,057	\$468,035	\$573,230	\$625,880
Construction	731,000	731,000	659,600	779,875	827,050
Total	\$1,165,057	1,165,057	1,127,635	1,353,105	1,452,930
Differential Capital Cost ¹ (Decrease)		—	(37,422)	188,048	287,873
Operating Costs					
Labor ²	1,304,583	691,275	536,778	621,441	595,360
Food	553,029	534,123	803,548	534,123	523,441
Supplies ³	47,267	56,216	51,994	51,994	51,994
Energy	6,691	6,691	7,151	9,485	10,996
Total ⁴	\$1,904,880	\$1,281,614	\$1,392,320	\$1,207,558	\$1,170,795
Cost/Meal ⁴	\$4.03	\$2.71	\$2.95	\$2.56	\$2.48
Differential Operating Cost ^{1,4} (Decrease)		—	110,706	(74,056)	(110,819)
Differential Operating Cost ^{4,6} (Decrease)		(623,266)	(512,560)	(697,322)	(734,085)
Annual Costs ⁵	2,056,136	1,430,046	1,541,325	1,387,842	1,365,711
Cost/Meal	\$4.35	\$3.03	\$3.26	\$2.94	\$2.89
Differential Annual Cost ¹ (Decrease)		—	111,279	(42,204)	(64,335)
Differential Annual Cost ⁶ (Decrease)		(626,090)	(514,811)	(668,294)	(690,425)

¹ Improved Conventional System as base.

² Including fringe benefits.

³ Includes maintenance cost of Insulated Tray System (conventional system only).

⁴ Annualized cost of labor, food, equipment, construction, energy, and supplies assuming 10-year beneficial life for equipment and 25-year beneficial life for construction.

⁶ Current operations as base.

TABLE 10
DAILY WORKLOAD BASIS – 550-BED FACILITY

Inpatient Meals		% Patient Meals
Ward	1,225 (50%)	82
Dining Hall	<u>275 (11)</u>	18
Total	1,500 (61%)	100
Non-Patient Meals	<u>950 (39)</u>	
Total Meals	2,450 (100)	
Special Diet Meals	675	45

Cost Elements

Equipment Requirements

A review of equipment costs (Table C-5) indicates that increased refrigeration and ward equipment requirements for any of the advanced preparation concepts are not overcome by reductions in other areas. The end results are increases in equipment cost of 27, 53, and 69% for the convenience, the cook-chill, and the ready foods concepts, respectively, over the conventionally designed system.

Space Requirements

Space, as with the other size facilities, is saved in the system designed under the convenience concept (Table D-3). With the in-house advance preparation concepts there is a need for 6% more space for the cook-chill and 12% for the ready foods concept compared to the conventionally designed system as designed for this size MTF.

Labor Costs

Again, reductions in personnel needs are indicated in Appendix A, Table A-5 for the systems designed under advance preparation concepts. For this scale of operation, as in the 100-bed facility, the average cost or skill level of the employees can be reduced by the use of the advance preparation methods. The relative numbers of employees under each concept remains unchanged compared to the smaller size facilities due to the previously discussed advantages of increasing the time between production and service.

Energy Utilization

The effect of utilization of advance preparation methods is similar to that found in the smaller facilities (Table E-1). As with the smaller facilities, the ready foods concept

increases energy requirements over the improved conventional system. This increase is 72%, the most for any sized facility.

Cost Analysis

Again the ready foods concept will provide the most cost effective mode of operation. Even in the large facility, the decrease in overall costs (Table 11) through reductions in kitchen workers is large enough to offset the increases created by the additional equipment and energy requirements. With the increases in operating costs and capital expenditures for the convenience concept, and only a moderate decrease in expenses for a cook-chill system, the system designed under the ready foods concept is the best alternative.

Analysis

Economic Evaluation

Over this range of sizes the most cost-effective mode of operation for food service divisions in Army MTF is seen to be under a ready foods concept. The concepts, as applied to MTF, in order of increasing cost-effectiveness are convenience, improved conventional, cook-chill, and ready foods. In fact, as can be seen graphically in Figure 5, the ranking is not affected by size. The graphical articulation of Tables 7, 9, and 11 shows that for Army facilities reductions in labor costs through the use of convenience foods cannot offset the increased cost of these foods, but that the use of on-site advance preparation methods provide labor savings greater than the cost of additional equipment, space, and energy requirements.

As mentioned in the discussion of the advantages of these concepts, labor savings are produced through economies resulting from the use of additional equipment to increase the time lag between food preparation and food service. With the reduction in perishability provided by frozen or chilled foods, distribution need not immediately follow production, and workload peaks and valleys are significantly reduced. Due to these tradeoffs between labor and other costs, however, the resulting concepts have cost elements with different magnitudes and with various rates of increase over time (Table 12). The possible changes in ranking for cost effectiveness of the concepts due to inflation of the elements which make up the operating costs of a facility is evaluated over a ten-year period (Appendix F) in Tables F-1, F-2, and F-3 and presented graphically in Figures 6, 7, and 8. These analyses show that inflation should not, in the near future, affect the cost of the systems.

TABLE 11
COST COMPARISON OF ALTERNATIVE CONFIGURATIONS—550 BED MTF

	Existing System	Improved Conventional	Convenience	Cook—Chill	Ready Foods
Capital Cost					
Equipment	\$645,377	\$645,377	\$779,115	\$938,220	\$1,033,380
Construction	1,145,375	1,145,375	1,023,825	1,227,400	1,300,500
Total	1,790,752	1,790,752	1,802,940	2,165,620	2,333,880
Differential Capital Cost			12,188	374,868	543,128
Operating Cost					
Labor ²	2,110,430	1,193,467	853,322	1,107,121	1,055,226
Food	965,790	1,010,503	1,520,225	1,010,503	990,293
Supplies ³	98,367	107,588	98,397	98,397	98,397
Energy	12,704	12,704	13,979	18,722	21,117
Total ⁴	\$3,174,588	\$2,311,558	\$2,471,944	\$2,216,021	\$2,143,916
Cost/Meal ⁴	\$3.55	\$2.59	\$2.76	\$2.48	\$2.40
Differential Operating Cost ^{1,4} (Decrease)			160,386	(95,537)	(167,642)
Differential Operating Cost ^{4,6} (Decrease)		(863,030)	(702,644)	(958,567)	(1,030,672)
Annual Costs ⁵	3,398,150	2,539,575	2,714,271	2,509,145	2,461,872
Cost/Meal	\$3.80	\$2.84	\$3.04	\$2.81	\$2.75
Differential Annual Cost ¹ (Decrease)			174,696	(30,430)	(77,703)
Differential Annual Cost ⁶ (Decrease)		(858,575)	(683,879)	(889,005)	(936,278)

¹ Improved Conventional System as base.

² Including fringe benefits.

³ Includes maintenance cost of Insulated Tray System (Conventional System only).

⁴ Energy costs not included in operating costs; provided for comparison only.

⁵ Annualized cost of labor, food, equipment, construction, energy and supplies assuming 10-year beneficial life for equipment and 25 year beneficial life for construction.

⁶ Current operations as base.

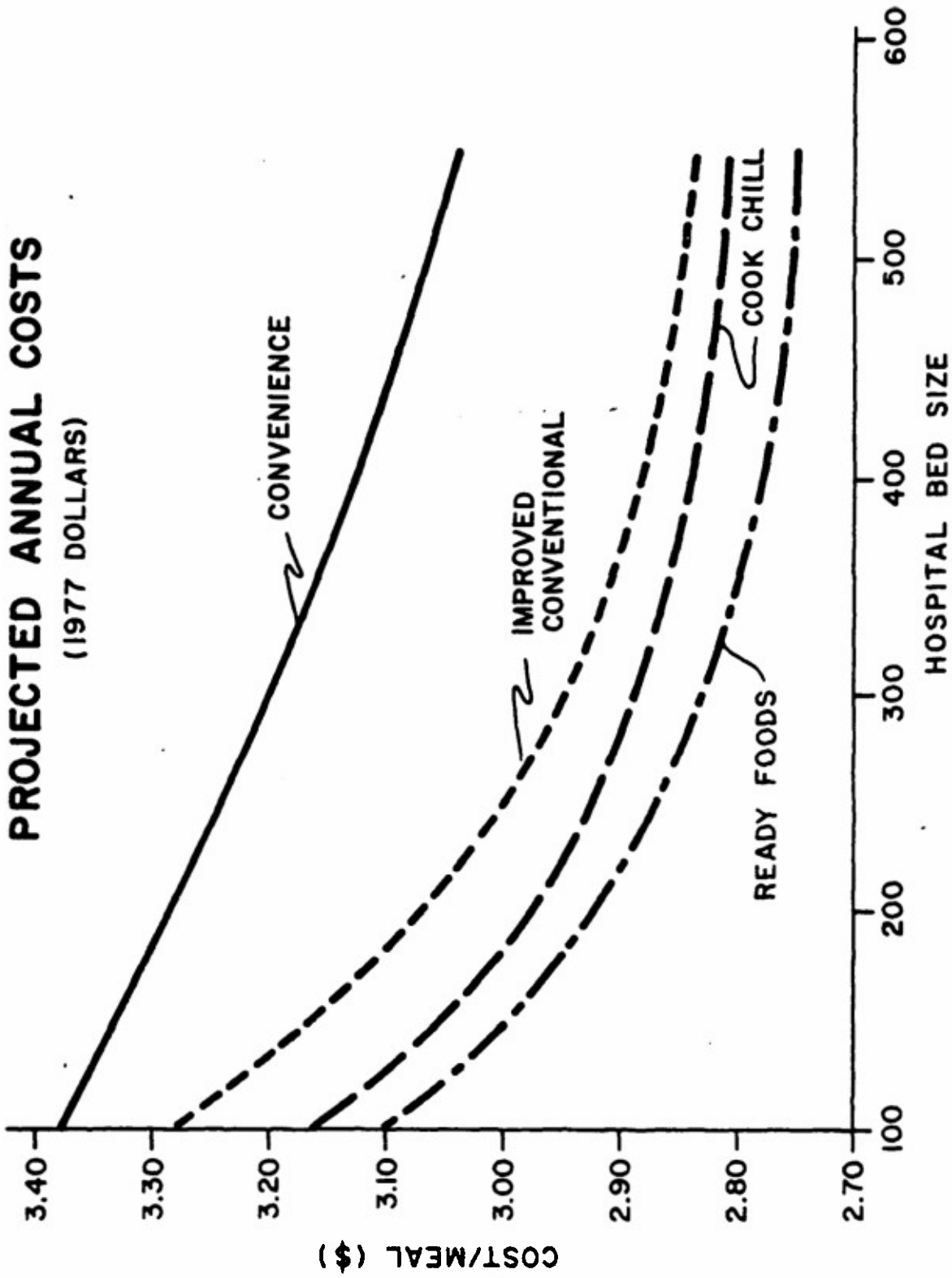

Figure 5. Projected Annual Costs

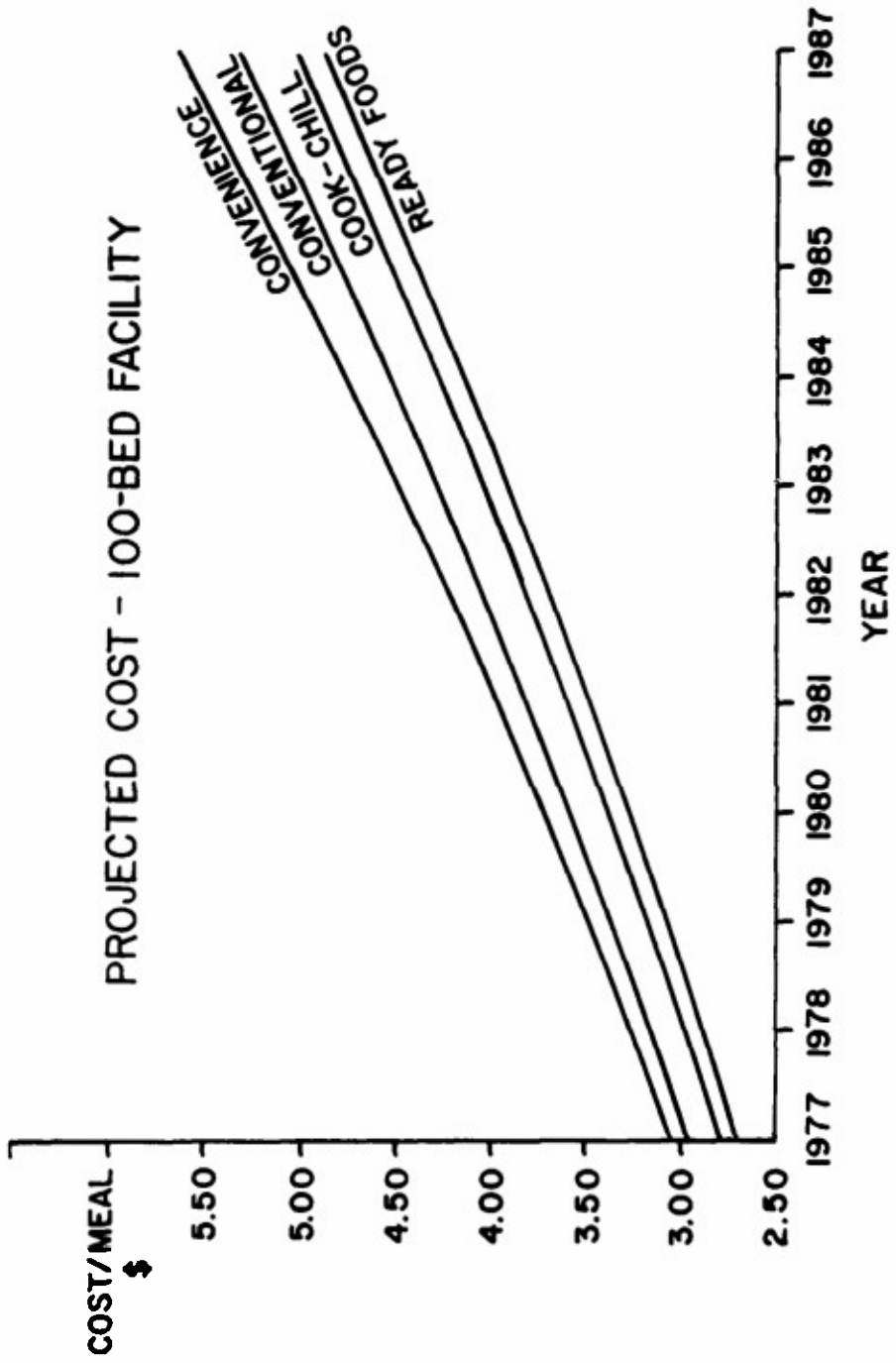

Figure 6. Projected Cost - 100-Bed Facility

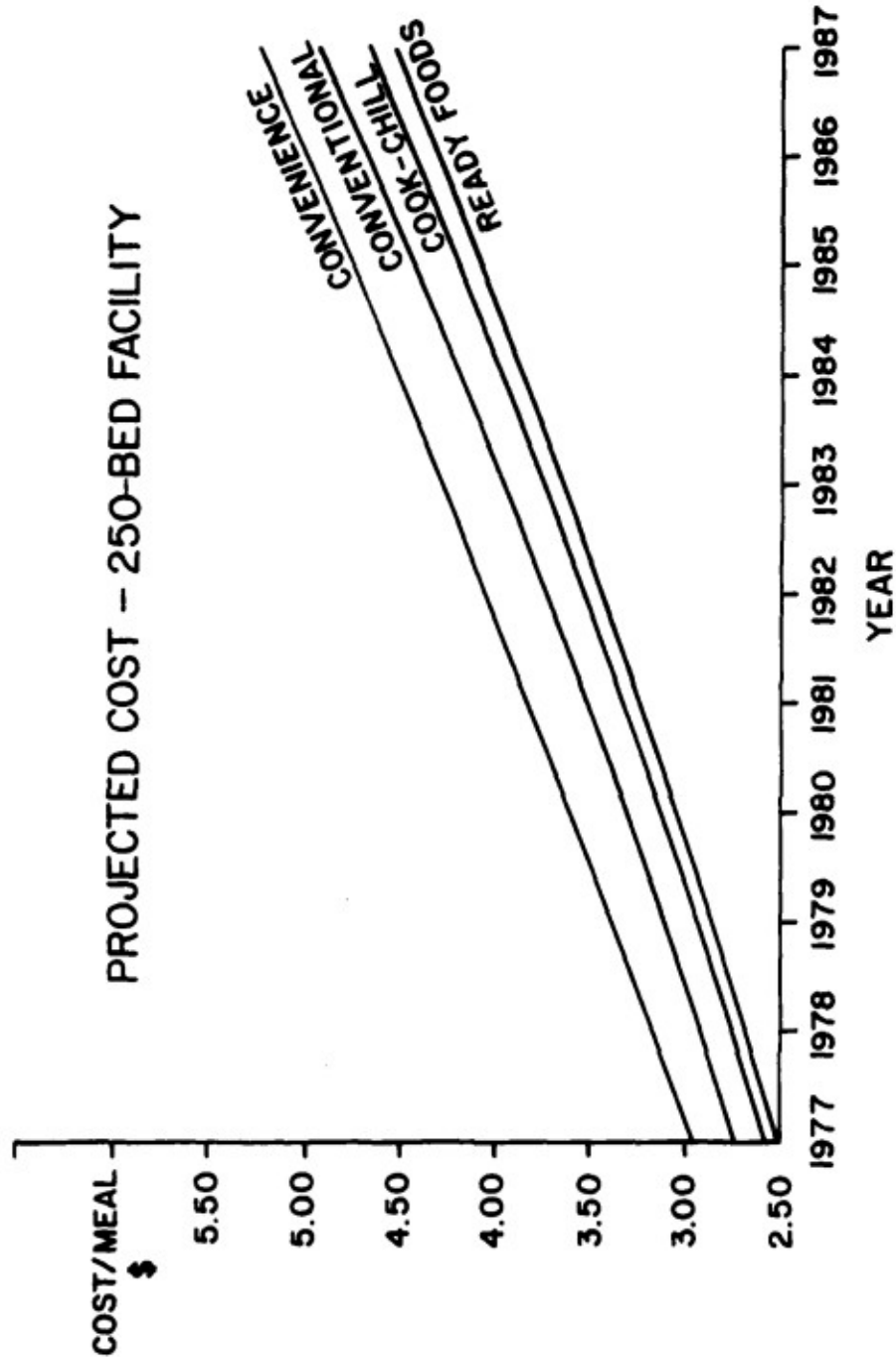

Figure 7. Projected Cost - 250-Bed Facility

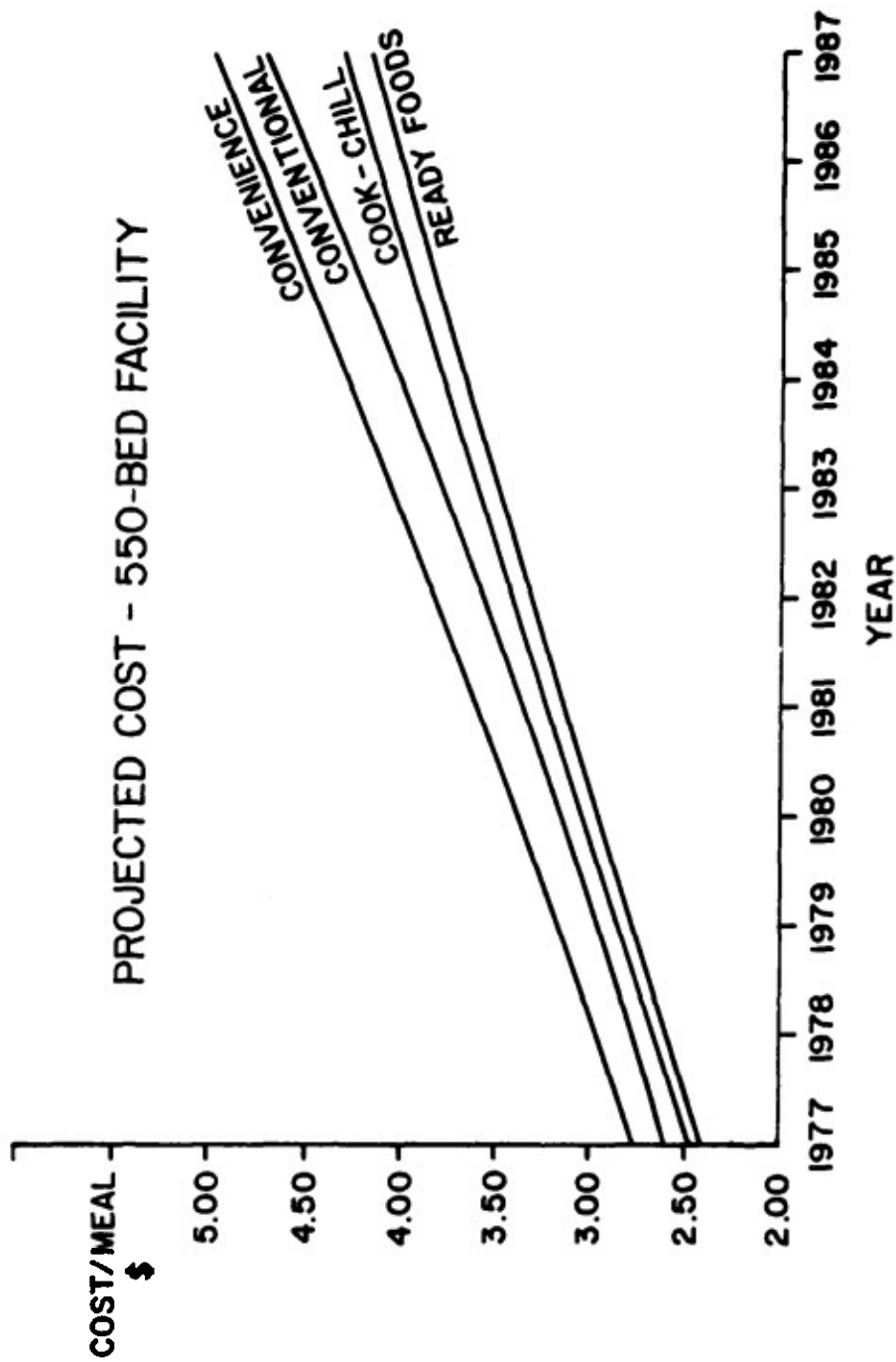

Figure 8. Projected Cost - 500-Bed Facility

TABLE 12
INFLATION RATES

Cost Element	Rate of Inflation	Source
Labor	4-7%*	DOD Guidelines
Equipment	4.3	DOD Guidelines
Food	7	DOL, USDA
Energy	10	Dept of Commerce

*Dependent on Status as Military, Wage Grade, or General Schedule Employee.

Conclusions

All of the new concepts as designed for Army hospitals represent significant savings when compared to the current concept of operation. The savings are a direct result of staff reductions resulting from the labor savings provided by these new concepts of operation and additional equipment.

The use of the ready foods (cook-freeze) concept for the design of food systems in Army MTF of bed sizes in the range of 100 to 550 beds will produce the most economical meals in terms of either operating or annual cost. The use of this concept can provide savings in operating costs ranging from 32% in the larger facilities to 41% in the smaller, or savings in annual costs of 28 to 36%. The other approaches are decreasingly cost effective in the order cook-chill, improved conventional, and convenience. With increasing size, the cost differentials become slightly smaller; but the advantage of the ready foods, cook-chill, and improved conventional concepts are still apparent.

The relative cost effectiveness of these concepts should remain the same over the next decade despite the variations in the rates of inflation of their direct cost elements. The capital intensive cook-chill and ready foods concepts have the lowest rate of increase due to their dependence on cost elements which are anticipated to be least affected by inflation.

SECTION IV

Consumer Acceptance

A. The Effect of Consumer Acceptance Preparation Methods on Acceptability

Objective

Methods of food preparation and the systems used to reheat the foods are important modifiers of quality of food and consequently consumer acceptability. Unfortunately, the question of product acceptability in advance preparation systems has been addressed¹⁰⁻¹³ mainly in terms of minimum standards of palatability or microbiological safety. Comparisons of the acceptability of cook-freeze items stored under different conditions^{10,11,14} or reheated using different techniques¹⁴⁻³⁰ have been made. Other studies³¹⁻³⁴ have compared foods cooked using different oven types. In general, these studies have considered differences between a small number of items contrasting only one or two techniques. The paucity of complete and comparable studies to use as a basis for a choice of a total hospital food preparation system makes necessary a study to provide useful information about the consequences of complex operations and/or equipment on consumer acceptance of finished products.

¹⁰Walker, G. C. and Tuomy, J. M., "Evaluation of Frozen Meat Entrees", Tech Report, NATICK/TR-77/013, June, 1977, (AD A041638).

¹¹Tuomy, J. M., Walker, G. C. and Hinnergardt, "Pilot Plant Evaluation of Frozen Entree Items for the Navy," Tech Report, NATICK/TR-76/31-FEL, September, 1976, (AD A031327).

¹²Walker, G. C., Tuomy, J. M., and Kanter, C. G., "Egg Products for Use in a Cook-Freeze System," Tech Report, NATICK/TR-76/28-FEL, August, 1976, (AD A031023).

¹³Walker, G. C. and Tuomy, J. M., "The Storage Life of Precooked Frozen Chicken," Tech Report, NATICK/TR-75/24-FEL, October, 1974, (AD A000680).

¹⁴Rainsford, P., "A Study Comparing the Financial, Managerial, and Reconstitution Differences between Conventional and Convenience Food Service Systems Utilized by Selected Colleges, Universities and Hospitals," Ph.D. Thesis, Cornell University, Ithaca, New York, 1974.

¹⁵Fries, J. A. and Graham, D. M., "Reconstituting Preplated Frozen Meals with Integral Heat," *Food Tech*, 26, 76 (1972).

¹⁶Merrick, M. and Sutton, P. J., "The Minimal Cooking Concept," *Hospitals*, 46,

92 (1972).

¹⁷McIver, C., "Batch Cooking," *Ibid*, 44, 94 (1970).

¹⁸Schneider, R. F., "In-House Production Capacity Proves Effective," *Ibid*, 48, 71 (1974).

¹⁹Trueman, R. F., "A Systems Approach to Reconstitution Equipment," *Canadian Hospital*, 49, 71, June, 1972.

²⁰Kaird, F. A., "Implementing the Chilled Food Concept," *Hospitals*, 46, 97 (1972).

²¹Clemence, E., "The Mystery and Mastery of Microwave," *Dimensions in Health Service*, 53, 32 (1976).

²²Hysen, P., "Ready Foods May Provide Ready Savings," *Modern Hospitals*, 116, 95 (1971).

²³Schirmer, W. E., "Convenience Foods System Saves Labor, Money," *Hospitals*, 46, 110 (1972).

²⁴Pinkert, M. S. and Hysen, P., "Pros and Cons of Three Food Systems," *Canadian Hospital*, 50, 13 (1973).

²⁵Ellis, C., "Old New Meld in Ready Foods System," *Modern Health Care*, 6, 41 (1976).

²⁶Rigley, E., "An Overview of Food Service Systems," *Dimensions in Health Service*, 51, 42 (1974).

²⁷Pinkert, M. S., "Basic Planning Concepts for REady Foods Systems," *Canadian Hospital*, 49, 32 (1972).

²⁸Silvin, R. R., "Community and Commercial Usage of the Ready Foods System," *Ibid*, 50, 30 (1972).

²⁹Williamson, B. J., "Tomorrows System - The Food Factory - Today," *Perspective in Practice*, 66, 499 (1975).

³⁰Clagg, C. A. and Crowley, A. M., "Reheating Frozen Entrees," *Hospitals*, 46, 90 (1972).

³¹Kylen, A. M., Charles, V. R., McGrath, B. H., Schleiter, J. W., West L. C., and VanDwyne, F. O., "Microwave Cooking of Vegetables," *J. Amer. Dietetic Assoc.*, 39, 321 (1961).

³²Kylen, A. M., McGrath, B. H., Hallmark, E. L., and VanDwyne, F. O., "Microwave and Conventional Cooking of Meat," *Ibid*, 45, 139 (1964).

³³Eheart, M. S. and Gott, C., "Conventional and Microwave Cooking of Vegetables," *Ibid*,

An experiment was conducted to examine the comparative differences in consumer acceptance of food items which were prepared by cook-chill, cook-freeze (ready foods), and convenience (commercial heat-serve) methods, and which were reheated using various methods commonly employed in hospital food service systems (i.e., convection, microwave, conduction, and infrared ovens). The particular food items were selected because they are (1) representative of those typically found on hospital menus, (2) can be prepared using one standard recipe, (3) are considered to be problem items (i.e., unforgiving foods), and (4) are available as hospital convenience foods. The results of the consumer taste panel³⁵ evaluations provide information across the several foods and food categories about comparative differences in food acceptability caused by preparation/storage methods, by reheating methods, and/or by the effect of interaction of these two equipment related variables.

Food Items

The ten food items were selected from four menu categories to reflect the relative importance of the meal components in an overall acceptability measure in a menu.³⁶ The four main entrees included fried chicken, hamburger on a bun, grilled ham and cheese sandwich, and turkey a la king, and the breakfast entrees were scrambled eggs and pancakes. The vegetables consisted of broccoli and carrots, and the starches were rice pilaf and french fries.

Methodology for Evaluation of Concepts

The procedures employed in this experiment simulated the handling of each product as it would be carried out in Army hospital food service environments operating under the different food system concepts. Wherever possible, all items were prepared from the same shipment of raw ingredients. The ready foods items were blast frozen (-30°F, -34°C) as quickly as possible after cooking, stored at -10°F (-23°C) for one to two weeks, and tempered overnight at 40°F (4°C) prior to reheating. Similarly, cook-chilled foods were rapidly cooled immediately after cooking, generally using an ice-water mixture, and then stored for two days at 40°F (4°C) before reheating. Convenience food items were procured which matched, as nearly as possible, the items prepared in-house. These frozen food items were tempered overnight at 40°F (4°C) prior to reheating.

44, 110 (1964).

³⁴Carpenter, L., Abraham, H. C., and King, G. T., "Tenderness and Cooking Loss of Beef and Pork," *Ibid*, 53.353 (1968).

³⁵Peryam, D. R., and Pilgrim, F. J., "Hedonic Scale Method of Measuring Food Preferences," *Food Tech*, 11, 9 (1957).

³⁶Rogozenski, J. E. and Moskowitz, H. R., "A System for the Preference Evaluation of Cyclic Menus," *Tech Report NATICK/TR-75/46-OR/SA*, October, 1974, (AD A005158).

Reheating was carried out using standard procedures and guidelines from the equipment manufacturers. Cooking times were based on the length of time necessary to heat the item to 160°F (71°C). The chilled and tempered items were reheated from 40°F (4°C) to 160–170°F (71–77°C) by a microwave oven under plastic wrap, by a Regethermic™ infrared oven using porcelain plates and stainless steel covers, by a 3M Integral Heat Oven™ (i.e., a conduction oven) using dishes and covers designed for that process and by a standard convection oven with an aluminum foil covering. In no case were any items held for longer than 15 minutes after reheating. All items were immediately served or transferred to holding ovens maintained at a calibrated temperature (165 ± 5°F; 74 ± 3°C) until served. Only foods reheated by conduction were maintained in that oven, since the unit is equipped with an automatic holding cycle.

The control for each food item was prepared by conventional methods (cook-serve) and was held briefly under steam table conditions before being plated and served. As with the samples prepared using the advance preparation techniques, the control was not held for any longer time than would customarily be the case in the patient tray assembly area or the cafeteria service line. Generally, this required that control batches be prepared every 10 to 15 minutes. All items were presented to panelists on the same type of prewarmed serving ware.

Sensory testing was conducted for each item using 60 subjects randomly selected from the population of 550 people who have volunteered for the taste-testing panel at the US Army Natick Research and Development Command.³⁷ These subjects were not informed of the purpose of the equipment. Separate panels were formed for evaluation of each food item consisting of three groups of twenty persons each. Each group sampled items involving a different preparation method, with each individual in the group receiving five samples of a single food item in a random order -- the control and one sample from each reheating method. A sample was rated on a 9-point hedonic scale, ranging from 1 (expressing extreme dislike) to 5 (neutral) to 9 (expressing extreme like). Table 13 summarizes the experimental design.

A three-way analysis of covariance (ANCOVA)³⁸ was performed on the data using BMD computer program P2V, "Analysis of Variance and Covariance, Including Repeated Measures".³⁹ The results are included in Appendix H. The three factors examined were food item, preparation method, and reheating method. This analysis distinguishes effects of hedonic rating (acceptability) due to the three factors or interactions among the factors, after adjusting the hedonic ratings to take into account the individual differences in the

³⁷ See reference 35.

³⁸ Winer, B. J., "Statistical Principles in Experimental Design," McGraw Hill, New York, 1962.

³⁹ Dixon, W. J., BMDP: Biomedical Computer Programs, University of California Press, Berkeley, 1975.

preference ratings for a food item by each group. The probabilities associated with the F statistic values are presented in Table 14. At a 5% significance level, i.e., if $p < .05$, the effect is considered to be significant.

TABLE 13
EXPERIMENTAL DESIGN FOR EACH OF 10 FOOD ITEMS

REHEATING METHOD	PREPARATION METHOD		
	Cook-Chill	Cook-Freeze	Convenience
Control ^a	Group I ^b	Group II ^b	Group III ^b
Microwave	Group I	Group II	Group III
Convection	Group I	Group II	Group III
Conduction	Group I	Group II	Group III
Infrared	Group I	Group II	Group III

^aThe control sample was prepared in the conventional cook-serve manner.

^bEach group consisted of 20 individuals.

Analysis and Discussion

For every menu category, except breakfast entree, food is a significant factor. However, the primary factors of concern in this study are preparation method and reheating method. Preparation method is significant in two categories: breakfast entrees and starches. Reheating is significant for the breakfast entree and vegetables. Also, many interaction terms are significant, indicating a complex system about which no simple conclusions can be drawn. Moreover, in all cases one or more of the factors comprising the interaction are also significant. When this is true, it is most interesting to look at the interaction, as the effect of the individual factor(s) is confounded by the interactions. The most interesting interaction is the oven \times food \times preparation effect (OFP). This complex term indicates that, over all ten individual food items, the rating is affected by different reheating oven and preparation method combinations. Since this difference does not exist among the food items in menu categories, the different combinations of oven-preparation methods produce the primary effect on the ratings. That is, different

TABLE 14

PROBABILITY OF F EXCEEDED FOR ANCOVA'S BY MENU CATEGORY

Effect	Main Entree	Breakfast Entree	Vegetable	Starch	All Foods
F ^a	0.000*	0.860	0.005*	0.000*	0.000*
p ^b	0.697	0.023*	0.051	0.003*	0.448
O ^c	0.101	0.000*	0.001*	0.113	0.103
Interaction					
FP	0.000*	0.449	0.319	0.588	0.000*
OF	0.236	0.139	0.385	0.017*	0.000*
OP	0.012*	0.298	0.856	0.157	0.291
OFF	0.678	0.162	0.146	0.149	0.000*

*Significant at $p \leq 0.05$.

^aEffect of food items.

^bEffect of preparation methods.

^cEffect of reheating method.

menu categories, not food ratings within these categories, react differently to these oven-preparation combinations.

The significance of the oven x food (OF) and preparation x food (FP) interactions for all the foods reveals that individual food items have different degrees of compatibility with ovens or with preparation methods, particularly for those menu categories which also show a significant interaction. For example, cook-frozen turkey is rated high compared to cook-chill or convenience turkey, and microwaved french fries low compared to french fries reheated in the other ovens. Only main entrees are affected by the remaining interaction, reheating oven x preparation, indicating that for main entrees the different combinations affect the consumer acceptability.

In general, there is no combination of methods that is superior or inferior for all foods. However, for the separate menu categories, differences are indicated.

Post-Hoc Analysis

The mean hedonic rating for preparation methods by menu category is shown in Table 15, and Table 16 presents the same data for the reheating methods. Since the ANCOVA indicates that statistically significant differences exist between acceptability ratings in certain menu categories; Duncan's Multiple Range Test was used to find the grouping and/or ranking of these means.⁴⁰ This comparison differentiates between groups of means.⁴¹ Thus, the means can be grouped and/or ranked to determine the best method or combination of methods with the highest acceptability for each menu category as shown in Table 17. It can be seen that no single method is preferred in more than one menu category.

Review of Table 16 indicates that the mean hedonic rating for the control sample may exceed the mean hedonic for any reheating method in each menu category. The Duncan's Multiple Range Test did determine mean differences for the four reheating methods and control method (in effect viewing all five methods as reheating methods) and showed the statistically significant groupings and their rankings. For all menu categories and for all foods the control mean (Table 18) was found to be the greatest ($P \geq 0.05$). Thus, the overall acceptability of cook-serve (i.e., service line) food is superior to that prepared by any other method.

⁴⁰ Kirk, R. E., *Experimental Design: Procedures for the Behavioral Sciences*, Brooks/Cole, Belmont, Ca., 1968.

⁴¹ Nie, Normal H., *SPSS: Statistical Package for the Social Sciences*, McGraw Hill, New York, 1975.

TABLE 15
ADJUSTED MEAN HEDONIC RATINGS^a FOR PREPARATION
METHODS BY MENU CATEGORY

Menu Category	Preparation Method			Marginal
	Cook—Chill	Cook—Freeza	Convenience	
Main Entree (4) ^b	6.26	6.10	6.16	18.52
Breakfast Entree (2)	5.88	5.13	5.15	16.16
Vegetable (2)	5.97	6.25	5.56	17.78
Starch (2)	5.25	5.23	6.02	16.50
All Foods (10)	<u>5.92</u>	<u>5.77</u>	<u>5.81</u>	17.50
	29.28	28.48	28.70	

^aData reflect covariance adjustments of the control sample rating.

^bNumber of food items in category.

TABLE 16
MEAN HEDONIC RATING FOR HEATING DEVICE AND
CONTROL BY MENU CATEGORY

Menu Category	Reheating Method				
	Microwave	Convection	Conduction	Infrared	Control
Main Entree	6.16	6.34	6.12	6.07	7.14
Breakfast Entree	5.90	4.84	5.59	5.22	6.81
Vegetable	5.88	6.22	5.58	6.03	6.93
Starch	5.42	5.69	5.55	5.34	6.88
All Foods	5.90	5.89	5.79	5.75	6.98

TABLE 17
BEST METHOD OR GROUPS FROM RANGE TESTS

Menu Category	Preparation Method	Reheating Method
Breakfast Entree	Cook-Chill	Conduction & Microwave
Vegetable	Cook-Chill and Cook-Freeze	Convection & Infrared
Starch	Convenience	

TABLE 18
MEAN HEDONIC RATINGS BY PREPARATION METHOD
AND BY MENU CATEGORY

Preparation Method	Main Entree (4)	Breakfast Entree (2)	Vegetable (2)	Starch (2)	All Foods (10)
Cook-Chill	6.25 (7.11)*	5.94 (7.05)	5.93 (6.83)	5.24 (6.85)	5.92 (6.99)
Ready-Frozen	6.17 (7.35)	5.03 (6.40)	6.19 (6.80)	5.29 (7.05)	5.77 (6.99)
Convenience	6.09 (6.95)	5.19 (6.98)	5.65 (7.15)	5.97 (6.75)	5.81 (6.96)

*Mean of Control for each group indicated in parentheses.

Conclusions

Among the advance preparation methods, the effects are extremely complex and are food item related. In general, for all foods no significant effects on hedonic ratings are the consequence of either preparation or heating method. Also, interactions between these methods do not affect the hedonic ratings. Acceptabilities of all food items (i.e., a representative menu) which are produced by the different combinations of advanced preparation and reheating techniques, are not different.

Differences due to methods are found in the mean hedonic ratings of individual food items, or for items grouped within some specific menu category these differences indicate superior consumer acceptability for certain methods in these specific cases. These ratings are not found to be consistent across the ten menu representative food items or even across the two items of some menu categories. These conflicting differences and the complex interactions preclude the selection of a preferred method or methods using indices of consumer acceptability. The selection of a system must, however, be made with careful consideration of the food items which make up the menu.

Under actual operating conditions the acceptability of conventionally prepared hospital food, which is held at serving temperature after preparation, is modified by two factors, these are the length of the holding time and the methods used to maintain the proper temperature. Thus, although the control is found better than foods prepared by the advance preparation techniques, these higher ratings should not be construed as being representative of a conventional system, as the degrading effects of temperature maintenance on food quality⁴² are not reflected. The cook-serve food items are freshly prepared items similar to short order fare or food held only briefly on a service line before consumption, and not institutional or volume produced items.

⁴²Hitchcock, M. J., Moble, I. and Thorud, S., "Effect of Holding on Broccoli Prepared in Volume," J. Amer. Dietetic Assoc., 49, 418, (1966) and references cited therein.

B. Consumer Attitudes Regarding Hospital Food Service

Objective and Methodology

A multihospital study of Army food services was conducted to develop and conduct a survey to assess patient and staff attitudes about the quality of the food service at Army Hospitals. The objectives of this survey are: (1) to identify those factors in the Food Service System which influence patient and staff satisfaction and morale, and (2) to determine the relative importance of such factors as related to consumer satisfaction and morale. Five Army medical facilities were surveyed in this study.* They were chosen on the basis of their relatively large and representative patient populations, their widely scattered geographic locations, and economic and time considerations. The questionnaires surveyed three populations:

- (1) Ward patients eating meals in their hospital room,
- (2) Ambulatory patients eating their meals in the hospital dining room, and
- (3) Hospital staff eating in the hospital dining room.

A total of 1,597 surveys which had been distributed equally among the three daily meals were administered. All the subjects were volunteers, and questionnaires were administered at, or shortly after, mealtime and collected no more than one hour later.

Analysis of Survey Data

Analysis of several survey items concerning both the overall food quality and service and the acceptability of specific meals yielded the results shown in Table 19. As discussed in detail in Section II, the general opinion of all meals eaten at the surveyed hospital falls between "neither good nor bad" and "good". The ward patients rate meals significantly higher than either the ambulatory patients or the staff, and rate the courtesy of ward food servers significantly higher. Possibly, these results were obtained because ward patients are served individually by the nursing staff or by orderlies, while ambulatory patients and staff are served by food service workers in the institutionalized dining hall.

The mean responses to the ten survey items which related directly to the specific meal just eaten (as rated on a 5-point scale) are shown in Table 19. Differences between groups are significant for:

*Letterman MC, Brooke Army MC, Eisenhower Army MC, Silas B. Hayes Army Hospital, and Moncrief Army Hospital.

TABLE 19

SUMMARY OF OPINIONS OF HOSPITAL FOOD AND FOOD SERVICE

General Opinions of Food Service

	Mean Rating of All Respondents	Mean Rating of Respondent Sub-groups		
		Ambul.	Ward	Staff
Opinion of All Meals Eaten in Hospital	3.78	3.61	3.95	3.70
Courtesy of People Serving Food	3.89	3.64	4.27	3.70
Aspects of Meal Just Eaten				
1) Appearance of Food Served	3.71	3.69	3.86	3.63
2) Aroma of Food	3.56	3.66	3.77	3.43
3) Variety of Items to Select*	3.12	3.05	3.21	3.07
4) Seasoning of Food*	2.63	2.63	2.63	2.63
5) Size of Food Portions	2.94	2.94	3.06	2.87
6) Food Served When You Want It*	3.02	2.94	3.01	3.03
7) Cleanliness of Dishes and Silverware	3.83	3.69	4.25	3.61
8) Attractiveness of Dishes, Silverware, and Tray	3.16	3.23	3.46	2.97
9) Thoroughness of Cooking Vegetables*	3.10	3.14	3.02	3.15
10) Tenderness of Meat	2.91	2.86	3.17	2.77

*No significant differences between means.

a. Appearance of Food Served – The significantly higher rating given to this item by ward patients probably results from the fact that they are served pre-loaded trays, more neatly arranged and garnished in comparison to dining hall meals where individuals must load their own trays and food is not as carefully arranged and seldom garnished.

b. Aroma of Food – The significant difference between ward patients and either ambulatory patients or staff of this item is probably caused by the fact that wards are characterized by antiseptic and medicinal odors, so aromas released by foods brought to the patient rooms are likely to be readily noticed as they are in sharp contrast to the prevailing odors. On the other hand, dining hall patrons are exposed to food odors upon entering so by the time they have waited in the serving line, received their food and begin eating, their olfactory system is so thoroughly accustomed to the food aromas that they do not readily attend to the aromas of the food on their plates.

c. Size of Food Portion – Ward patients rate the size of food portions as being slightly too large relative to ambulatory patients and staff, probably as a result of the fact that ward patients have lower mean ratings of appetite than do staff or ambulatory patients.

d. Cleanliness of Dishes and Silverware – Ward patients are given silverware prepackaged in individual bags which undergo scrutiny upon loading on trays. On the other hand, those eating in the dining hall must use silverware kept in bulk containers. This would increase the likelihood of dining hall patrons receiving soiled silverware, thus resulting in the lower rating given this item by ambulatory patients and staff.

e. Attractiveness of Dishes, Silverware and Tray – Since very little difference exists between dishes, silverware, and trays used in the dining hall and wards, the major factor resulting in the higher rating by ward patients on this item is probably the careful preloading of their trays in a neat and systematic manner by food service personnel.

f. Tenderness of Meat – The lower rating for tenderness of meat in the dining hall is probably due to the use of steam tables to keep the meats warm. Leaving meat on these tables for long periods of time will cause loss of moisture and increase the toughness of meat items.

Failure to find differences among the survey population on items 3 and 4 (Table 19) is probably due to the fact that the same variety of food items are available to ward patients as to dining room patrons and that salt and pepper are available for seasoning to taste. The lack of differences on items 6 and 9 (Table 19) is somewhat unexpected since ward patients must eat at preset times while the dining room is open for 1-½ to 2-½ hours at each meal, and since vegetables kept in the dining room steam tables can easily become overcooked relative to those brought directly to the ward.

Over all groups, those aspects of the meal which received lowest ratings were (1) the seasoning of the food (indicated to be too bland) and (2) the tenderness of meat. Higher

TABLE 20
EVALUATION OF TEMPERATURE OF HOT AND COLD FOOD ITEMS

	% of Respondents Reporting "No"		
	Ambulatory Patients	Ward Patients	Staff
11) Hot Food Items Correct Temperature*	28.6	27.9	29.3
12) Cold Food Items Correct Temperature	19.0	24.2	14.6

*No significant differences between percents.

rated factors are (1) cleanliness of dishes and silverware, (2) appearance of food, and (3) aroma of foods.

Consumer reactions to the temperature of the served food is shown in Table 20. There were no differences among the groups in their satisfaction or dissatisfaction with the temperature of the hot foods, but in each group, 30% of the respondents were not satisfied. Although, in general, there were fewer consumers who were dissatisfied with the temperature of the cold foods than with the hot items, a significantly larger portion of ward patients expressed dissatisfaction with the temperature of cold items served.

Regular diet meals were served to 79% of the patients. The remainder of the patients (13% of the ambulatory patients and 23% of the ward patients) received modified diets ranging from slightly modified, such as low sodium, to moderately restricted, such as soft bland. The patients on a regular diet gave an overall rating of 3.90 to the survey item assessing their opinions of all meals eaten in the hospital, while the special diet patients gave a rating of 4.07. No significant difference is found between these two groups at greater than the 10% level. However, differences between special diet and regular meals are found on several of the items which comprise the overall meal rating, as expected in the seasoning ($p \leq 0.025$), and in attractiveness of dishes ($p \leq 0.05$) and tenderness of meats ($p \leq 0.06$).

Statistical Significance of Survey Data

A composite score of items related to the meal just eaten (Items 1, 2, 4, 5, 7, 8, 9, and 10 in Table 19 and both items in Table 20) can be obtained for these ten items for the total population of respondents. The Cronbach's coefficient,⁴³ an index of reliability and generality of the items, has been calculated for this composite score. A value of 0.68 was obtained, which is an indication of internal consistency and interrelationship. Thus, the ten factors comprising the composite score for consumer acceptability fall within the range which indicates impact upon this variable.

The significance of the individual items which comprise the composite score can be examined by nonparametric analysis of the data. All twelve factors are associated with how an individual rates the overall food system according to group type and the meal attended (Table 21). One measure of the strength of the relationship between two variables is the contingency coefficient. Tables are constructed such that the assumptions implicit to test the independence of variables are met.* In Table 21, the statistically significant

⁴³Lord, Frederick M., and Novick, Melvin R. with Birnbaum, Alan, "Statistical Theories of Mental Test Score", Addison-Wesley Publishing Co., Reading, Ma, 1974, p. 87.

*Both variables (dependent and independent) are at least nominal (in fact they are both ordinal) and the expected frequency within all cells is greater than five.

TABLE 22**RANKING OF MEAL FACTORS IN OVERALL CONSUMER
ACCEPTABILITY – ALL POPULATIONS**

Factor	R Square	Beta
Appearance and Aroma	0.27617	0.32596
Cleanliness of Dishes and Silverware	.31637	.13440
Hot Food Items	.34202	-.10942
Tenderness of Meat	.35929	.12667
Variety of Items to Select	.37172	.08976
Size of Portions	.37777	.07761
Cold Food Items	.38072	-.05379
Seasoning of Food	.38231	.04059
Attractiveness of Dishes, Silverware, Trays	.38363	.04067
Thoroughness of Cooking Vegetables	.38366	.00575
Food Served When You Want	.38367	-.00251

TABLE 23

RANKING OF MEAL FACTORS IN OVERALL CONSUMER
ACCEPTABILITY – WARD PATIENTS

Factor	R Square	Beta
Appearance and Aroma	0.37208	0.41830
Cold Food Items	.39916	-.12575
Attractiveness of Dishes, Silverware, Tray	.41783	.12997
Tenderness of Meat	.43408	.12987
Size of Portions	.44798	.07087
Variety of Items to Select	.45385	.08515
Cleanliness of Dishes and Silverware	.45797	.06750
Hot Food Items	.45900	-.03559
Food Served When You Want	.45912	.01173
Thoroughness of Cooking Vegetables	.45914	-.00377

TABLE 24

**RANKING OF MEAL FACTORS IN OVERALL CONSUMER
ACCEPTABILITY – DINING HALL PATRONS**

Factor	R Square	Beta
Appearance and Aroma	0.22264	0.27501
Cleanliness of Dishes and Silverware	.27582	.16146
Hot Food Items	.30598	-.13281
Tenderness of Meat	.32346	.12343
Variety of Items to Select	.33731	.10234
Size of Portions	.34481	.08343
Seasoning of Food	.34802	.05985
Cold Food Items	.34869	-.02782

associations that exist between an item and the overall food system rating are indicated by giving the value of the contingency coefficient, while an asterisk indicates no association exists at the 1% level of significance. From Table 21, the staff population can be assessed as being the most predictive group; that is, given knowledge on how they rate each of the twelve items, it can be predicted how the overall food system will be rated by this population. Such predictions cannot be made as confidently given knowledge of the ambulatory or ward patient ratings of the twelve items. For example, how the ambulatory or ward patients rate the food system has little to do with how they rate the quality of the vegetables. Similarly, the overall food system rating is independent on how ambulatory patients rate the selection (variety of menu), portion sizes, seasoning, timeliness of the service, and cold items served cold.

Table 21 also indicates food appearance and aroma rank highest in relative importance to the other ten factors for all three populations. This relative importance is further verified by multiple linear regression analyses. When the meals served are evaluated by the entire population, the (Table 22) relative importance, Beta, of food appearance and aroma clearly stands out, followed distantly by cleanliness of dishes and silverware, tenderness of meat, and temperature of the hot food items. This is even more dramatically indicated in Table 23 where only ward patients are considered. In the ward the factors, such as temperature of cold food items, attractiveness of dishes, silverware, and trays, and tenderness of meat are of approximately equal importance; but nevertheless they are overshadowed when compared to the impact of food appearance and aroma. The data collected on individuals eating their meals in the dining hall (ambulatory patients and staff) also indicates the importance of food appearance and aroma. In this case, however, the dominance is not as strong, with cleanliness of dishes and silverware and temperature of hot food items being relatively more significant, Table 24.

Conclusions

As can be seen in Tables 19 and 20, significant differences exist between ward patients served meals in their rooms and those individuals eating in the dining hall (ambulatory patients and staff) with regard to the acceptability of the food service. Ward patients consistently rate the quality of both service and food to be higher than those eating in the dining hall. On the other hand, there is no significant difference in ratings given the food service patients on special diets versus those on regular diets. Thus, no particular attention need be focused on special diet meals, as those factors which improved the acceptability of food service for general diet patients will yield similar improvement for those on special diets.

The factors, in order of decreasing importance, contributing to the overall consumer perception of acceptability are aroma, appearance, cleanliness of service, food temperature, meat tenderness, and the variety of items. The other characteristics of food service also contribute, but have a much less significant direct impact. Overall, in the recent survey of consumers at Army facilities, the factors rated highest by consumers are cleanliness

of service, appearance, and aroma; while the lowest ratings were given to meat tenderness, seasoning, and the temperature of cold foods. Thus, the consumer perception of current hospital food service is predictably high because while some of the items which received low ratings are weighted moderately high, their importance as they impact the overall food service acceptability is completely overshadowed by the effect of the very highly weighted items (i.e., the appearance and aroma of foods, and cleanliness).

In his operation, the food service chief must be particularly concerned with maintaining or improving the quality of these critical acceptability elements. In particular, improvements of failures in the more highly weighted characteristics will have a greater effect on the overall acceptability. Other factors which can be influenced to enhance acceptability are the attitude of the food servers and the dining environment.

SECTION V

Cost-Benefit Analysis

Advantages and Disadvantages of Alternatives

In addition to the quantitative measures of cost and consumer acceptability developed in the earlier sections of this report, other more qualitative facts must be considered in comprehensive analysis of the food service concepts. The information concerning the advantages and disadvantages of the concepts has an impact on the qualitative systems' effectiveness factors that are defined later in this section.

The three advance preparation concepts (i.e., convenience, the cook-chill, and the ready foods concepts) have two common advantages. First, foodstuffs which have been properly cooled and refrigerated are much less perishable than items maintained at service temperature. Thus, the quality of foods prepared using these systems are less likely to suffer the losses in quality and nutrition found with conventional systems which hold the food product for an appreciable time under heat.⁴⁴

Secondly, the advance preparation of foodstuffs, by separating to some extent production from service, allows a more even workload distribution. With more standardized production schedules, fewer supervisory personnel are needed, management tasks are simplified, and staff can work in a more relaxed environment. These advantages are most evident under the ready foods concept with daily production mainly in support of an inventory, not customer demands.

Specific advantages and disadvantages can be attributed to each concept:

A. **Conventional Concept:** A majority of the products are prepared, assembled, and finished from basic raw ingredients daily. Food temperature, either hot or cold, is maintained until service to the consumer.

1. Advantages of a Conventional System

The principal advantage of the conventional system is that quality is controlled on-premises with proper supervision and with cooks preparing foods from standardized recipes. A second advantage, since the Army MTF food service has been operating with this concept, is that most employees would not have to be retrained should this concept of operation be continued. In addition no modifications to existing menus or recipes are necessary; and menus can be written to utilize seasonal items and can also be adjusted to take advantage of special low bids that may be quoted by a vendor.

⁴⁴See reference 42.

2. Disadvantages of a Conventional System

To produce high quality foods in a conventional system, skilled personnel must be hired and retained on staff. The cost of competent, skilled labor is extremely high and often their services are difficult to obtain. The necessity of producing three meals a day requiring two shifts of skilled personnel, seven days a week, 365 days a year, can be a definite disadvantage in attracting top quality cooks.

Preparation time for the next meal is limited to a few hours. With this extreme limitation placed on the system, mistakes can be costly and can create problems that will place a strain on consumer, staff, and management. This preparation lead-time also limits menu selection as those menu items that require long preparation can not be served. Scheduling of preparation is difficult and must be meticulous, as all foods must be ready to serve at the start of meal service.

The scheduling of labor efficiently is almost impossible as the workload factor during the day peaks during the three meals and slackens greatly between meals. Efficient scheduling of labor under this concept would require part time labor or split shifts. Within the civil service regulations this type of staffing has not proven feasible and has not yet been implemented successfully.

The forecasting of production demands is critical in any system. However, the relatively short time span between meals hampers the development of accurate forecasts. With this inability to estimate service demands, the frequency of overproduction or underproduction is increased, creating a need for menu substitution which, in turn, results in increased waste of foodstuffs. Beyond the waste, these inefficiencies are costly in terms of the amount of labor and energy needed to prepare small amounts of substitutes, and are also upsetting to consumer and staff.

B. Convenience Concept: Prepared product, either frozen, canned or prepackaged, is purchased from commercial sources. Reheating is accomplished on site immediately before service.

1. Advantages of a Convenience Food System

Convenience foods provide the simplest system, since the bulk of preparation is off-premises and so are production problems. The utilization of convenience foods allows the augmentation of individual menu selection without a corresponding increase in labor demands. Convenience foods increase food costs as the labor costs and profits (i.e., value added) of the producer are naturally added to the selling price. However, the purchase of labor in this manner, that is, by including some labor in the cost of foods, will naturally reduce the on-premise labor demands.

In purchasing items in a prepared state, the difficulties created by the seasonability of foods can be largely eliminated. Convenience foods also make it possible to offer items on a menu that might be too time-consuming for the hospital's own production staff, such as stuffed cabbage rolls and stuffed peppers.

Another possible advantage of this concept of operation is that improved quality standardization can be achieved. When a particular menu item is served, its quality will be the same each time that it is served. In a conventional food system, this quality standardization is often not achieved, as consistently reliable quality controls are difficult to obtain in the production of many batches of varying sizes.

With a minimum of on-site production, and with the food not being maintained at a high temperature, there are benefits for the food service staff. The food service area will be cleaner and quieter, and the employees can work on a normal schedule with few working odd hours.

2. Disadvantages of a Convenience System

Food acceptability is, of course, a matter of taste and personal preference. Convenience foods must be carefully selected to meet palatability and nutritional standards. Thus, for this concept to provide an acceptable level of performance, a thorough analysis and pilot testing program must be established to evaluate the range and depth of supply, product quality, nutritional content, cost per portion and method of packaging to insure an adequate supply of the variety of menu items necessary for a comprehensive food service system. This program must be ongoing to react to changes in supply, variety, and quality. It is generally difficult to find multiple suppliers for such items as precooked vegetables, potatoes, noodles, rice, prepared gelatins, and salads. This creates a market dependency which could make the system impractical. Several other items, most notably the special diet components, are still not readily available in the total convenience form, although their development is a new segment in which a great deal of research is being performed.

In flexibility of menu service often becomes a problem, since the only menu items that can be served are those items that are being stored on premises. Delays in deliveries can necessitate menu substitutions that can be costly and could also deplete stocks that are being held for another day's service. In addition, increases in workloads due to emergencies may be difficult to support with reduced equipment and staff. With the dependence on vendors, much of food service flexibility is lost.

With the stated advantage of standardization of quality, there is created an offsetting disadvantage of monotony, the monotony of sameness. Variety in quality levels above an acceptable level can be desirable and this can only be achieved in a convenience food system by purchasing the same food item from more than one supplier/producer. The logistics of having the proper product on the premises for the specified meal becomes unnecessarily complex.

C. Cook-Chill Concept: Products are prepared on site from raw ingredients and are not necessarily utilized the day of preparation, but are chilled for later use. Assembled patient trays or steam table pans are delivered chilled to the appropriate service area for reheating just prior to service to the consumer.

1. Advantages of a Cook and Chill System

As discussed earlier, food production in a cook and chill system is performed a day or more in advance of service, which permits greater flexibility in management of the system by reducing time requirements and allows distribution of the workload for food production and service more evenly throughout the day. Little or no retraining of employees is needed if a conversion is made from a conventional food system to a cook and chill system, since most cooking is still done from the same recipe/formula, but in a more labor efficient manner.

With the increase in time intervals between production and service, corrective measures can be taken if mistakes are made in production. That is, the adverse effects of inaccurate forecasting of production can be reduced as only those foods specified need to be taken from storage, and waste from overproduction can be reduced by carrying over unused but still chilled items to later meals.

2. Disadvantages of a Cook and Chill System

The disadvantages of a cook and chill system lies mainly in two areas. First, foods are not served fresh, possibly causing some initial loss in product acceptability. Secondly, recipes, primarily those using flour or cornstarch as a thickening agent, may have to be reviewed and modified as these may not reheat well once they are chilled.

In addition, precise microbiological audits become necessary with this advance preparation system. This requirement, if not supported by other areas of the hospital, may possibly necessitate additional skilled labor and sophisticated laboratory equipment.

D. Ready Foods Concept: Products are prepared on site from raw ingredients, then frozen for later use. Prior to service, products are thawed, and then patient trays are assembled and delivered chilled to a service area where they are reheated just prior to service to the consumer. Thawed and reheated food in bulk portions can also be used for dining hall service.

1. Advantages of Ready Foods System

A ready foods system utilizes a large batch, Monday through Friday, production schedule for hot foods. Items can be portioned for steam table pans, and/or plated immediately after production, and are then vacuum sealed and frozen for later use. By preparing items to support an inventory, daily production can be scheduled to minimize the difficulties caused by employee vacations, holidays, and absenteeism. The enhanced

flexibility of operating from an inventory allows a hospital food service to respond from its inventory to increased demand in times of emergency, to support other facilities by supplying frozen foods, and, by extending its hours of production, provide food under continuous increased workloads. The ability to easily increase capacity is a necessary requirement for any military facility and the inherent ability to support the other hospitals permits overall reductions in resources throughout the hospital system.

In addition, under a ready foods system, there is total control of all ingredients incorporated in the menu items, thus providing on-site quality level controls rather than accepting levels established by an off-premise producer. Special diet foods can be produced in more economical quantities and frozen to meet the dietetic requirements of an individual facility.

Under a ready foods program, greater menu variety can be achieved, since the entire menu cycle has already been prepared and is available. Since hot food production is carried out on a standard 40 hours, Monday through Friday, schedule, fewer highly skilled supervisory employees are required to cover weekends and later shifts, thus reducing labor costs.

2. Disadvantages of a Ready Food System

One of the prime disadvantages of a ready foods system is in the higher capital investment needed initially because of the additional freezers, refrigerators, large-scale cooking equipment and packaging equipment that are required. Some menu items such as fried eggs, salads, and sandwiches do not lend themselves to be produced in a total ready foods system. These products must be produced in the conventional manner on a seven-day schedule. As with the chilled concept, cooling can reduce product quality, and some recipe adjustments must also be made so as to achieve desired quality levels. There must also be adequate time spent in preliminary testing of large batch recipes and heating instructions; and in retraining of employees to new procedures.

Systems Effectiveness Evaluation

The systems effectiveness model used for the evaluation and comparison of the alternative system concepts is depicted in Figure 9. Systems effectiveness is defined in terms of the degree to which the ability of the hospital food service organization to perform its primary mission is affected by the assumed system design and operations, as compared to the existing system. Three major systems effectiveness parameters are considered in this analysis: consumer acceptance, operational performance, and personnel components. Each alternative is evaluated with respect to these parameters, and a total measure of effectiveness is calculated as a weighted sum of the parameter values. The weights assigned to each parameter are intended to reflect their relative importance in accomplishing the hospital food service mission.

A similar procedure is utilized in determining the individual parameter values as the sum of the relative contributions of several related factors to the system performance. The specific factors included are:

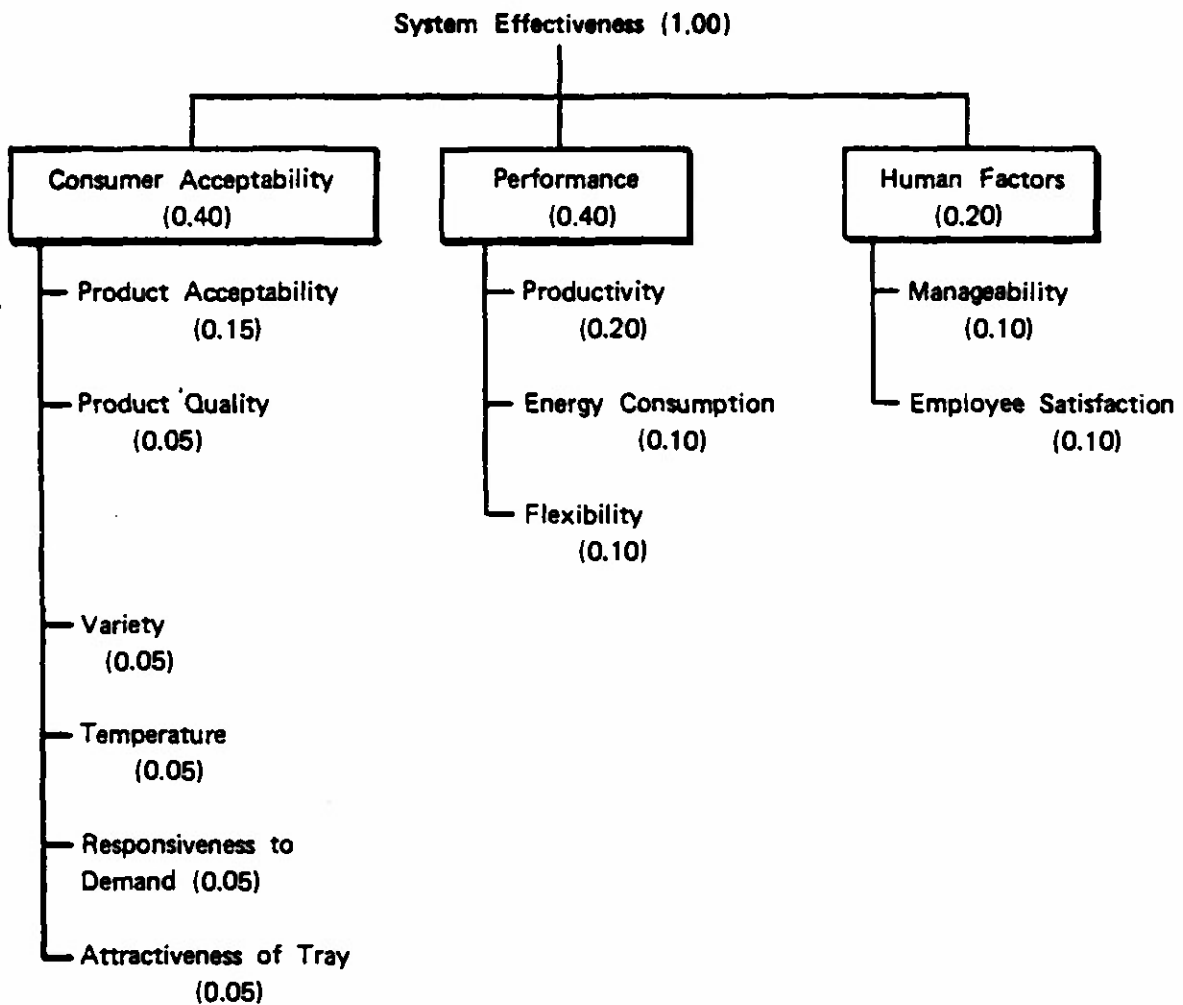

Figure 9. System Effectiveness

A. Consumer Acceptance

1. Product acceptability, which pertains to consumer reactions to appearance, flavor, and aroma of the food items served.
2. Product quality, with regard to preparation of food, e.g., tenderness of meat items and thoroughness of cooking vegetables.
3. Variety, or the possible choice of food items available on any given day.
4. Temperature, which is the ability to deliver food at the proper serving temperatures to ward patients.
5. Responsiveness to demand, that is, the capability to provide food service in a timely manner and to maintain the quality and temperature of the food in the event service is extended or delayed.
6. Attractiveness of the tray, including the general appearance and arrangement of dishware and flatware on patient tray service.

B. Operational Performance

1. Productivity or system output in number of meals per man-hour of labor expended.
2. Energy consumption, as required for food preparation, storage, and service.
3. Flexibility of the system to adjust to varying feeding requirements, operating problems, or to a variety of other kinds of change.

C. Personnel or Human Factor Components

1. Manageability, which assesses the degree of required supervision and the ease of directing and scheduling the workload.
2. Employee satisfaction, which is an overall measure of the work environment.

Numerical values, as follows, are assigned to each of the factors for a given alternative based on a comparison with current food service operations in Army Hospitals:

- +2 Significant improvement relative to present system.
- +1 Improved performance relative to present system.
- 0 Equivalent performance relative to present system.
- 1 Degradation in performance relative to present system.
- 2 Significant degradation relative to present system.

Associated weights for each factor were derived from the results of the economic analysis (Section III), consumer attitudes survey (Section IV), and the four acceptance tests (Section IV), or if they could not be developed analytically, represent best judgements based on observations in both military and non-military hospital food service operations.

The systems effectiveness evaluation is summarized in Table 25.

Comparison of Alternative Concepts

Up to this point, the cost analysis and the evaluation of systems effectiveness have been treated separately. A useful technique⁴⁵ for decision making is to integrate both values and produce a measure of the cost of producing each unit of effectiveness relative to a baseline system. This measure is expressed as the ratio of relative effectiveness to relative cost and is defined as the relative worth.

The utility, or relative worth, of a particular alternative can now be expressed simply as:

$$\text{Relative Worth} = \frac{1 + \Delta E}{1 + \Delta C}$$

where ΔE = Increase in system effectiveness

ΔC = Increase in system operating cost

Thus, the marginal utility, or net improvement in cost-effectiveness provided by each alternative as compared to the present mode of operations, is given by the relationship:

$$\text{Marginal Utility} = \text{Relative Worth} - 1.00$$

Using the values of cost from Tables 7, 9, and 11 and effectiveness presented in Table 25, the relative worth of each alternative, as a function of the size of the hospital, were calculated and are included in Table 26.

⁴⁵Cost and Operational Effectiveness Analysis Handbook, USA Training and Doctrine Command, Pamphlat 11-8, Ft. Monroe, Virginia 23651.

TABLE 25

Systems Effectiveness Evaluation

Factors	Factor Weight	Alternatives			
		Improved Conventional	Convenience	Cook Chill	Ready Foods
I. Acceptability (0.4)					
A. Total Consumer Acceptability					
Product Acceptability	0.15	0/0.00	-2/-0.30	-2/-0.30	-2/-0.30
Product Quality	0.05	0/0.00	-1/-0.05	-1/-0.05	-1/-0.05
Variety	0.05	0/0.00	1/0.05	0/0.00	2/0.10
B. Patient Acceptability					
Temperature	0.05	0/0.00	1/0.05	1/0.05	1/0.05
Responsiveness to Demand	0.05	0/0.00	1/0.05	1/0.05	1/0.05
Attractiveness of Tray	0.05	-1/-0.05	0/0.00	0/0.00	0/0.00
II. Performance (0.4)					
Productivity	0.20	1/0.20	2/0.40	2/0.40	2/0.40
Energy Consumption	0.10	0/0.00	0/0.00	-1/-0.10	-2/-0.20
Flexibility	0.10	0/0.00	-1/-0.10	1/0.10	2/0.20
III. Human Factors (0.2)					
Manageability	0.10	0/0.00	2/0.20	1/0.10	2/0.20
Employee Satisfaction/Morale	0.10	0/0.00	1/0.10	1/0.10	1/0.10
Increase in System Effectiveness Compared to Present System	-	.15	.40	.35	.55

TABLE 26

Comparison of Alternatives

	ALTERNATIVE SYSTEM CONCEPTS					
	Size of Facility	Current System	Improved Conventional	Convenience	Cook-Chill	Ready Foods
1. Relative Cost ^a	100	1	0.67	0.69	0.63	0.61
	250	1	0.67	0.73	0.64	0.62
	550	1	0.73	0.78	0.70	0.68
	Average ^b	1	0.69	0.72	0.65	0.63
2. Relative Effectiveness	All	1	1.15	1.40	1.35	1.55
3. Relative Worth	100	1	1.72	2.03	2.14	2.54
	250	1	1.72	1.92	2.11	2.50
	550	1	1.58	1.79	1.93	2.28
	Average ^b	1	1.67	1.94	2.08	2.46
4. Marginal Utility	100		0.72	1.03	1.14	1.54
	250		0.72	0.92	1.11	1.50
	550		0.58	0.79	0.93	1.28
	Average ^b		0.67	0.94	1.08	1.46

^aCost elements are labor, food, supplies, and energy.

^bWeighted average of six 550-beds, seven 250-beds, and twenty-five 100-bed MTF.

Results

Table 26 summarizes the results of the relative worth analysis. All the new concepts are superior to the present baseline system for hospital food service on the basis of cost and systems effectiveness. The preferred choice using the criteria of marginal utility is the ready foods concept with an average value of 1.46. The other alternatives, ranked in order of decreasing utility, are the cook-chill, the convenience, and the improved conventional with ratings of 1.08, 0.94 and 0.67, respectively.

The relative worth and marginal utility of these concepts decrease with hospital size, as economies of scale bring the relative cost of the existing system closer to the cost of its alternatives. Overall, however, the preferred concept provides an increase in relative worth for the hospital food service system of 146%, as compared to the baseline system.

Comparison with Current Operations

The four alternatives to the existing system were analyzed in Section III by designing recommended systems under the different concepts to operate within Army regulations under typical workloads for these sized facilities. The preferred ready foods concept, as defined in this earlier analysis, can be compared against composites of existing operations which are representative of the three different sized facilities in the existing food system (Appendix G) to evaluate the possible economies. The similarities in workloads and the projected reductions in manpower and in overall costs between the preferred concept and the representative composites are shown in Table 27. Significant reductions in the cost of labor and foodstuffs easily offset the increases in other relevant costs. Thus, savings of between 30% and 35% can be realized by using the ready foods concept in new construction. The actual reduction in operating costs would be slightly greater, approaching 40%, because energy and capital costs need not be considered as part of the cost of operation.

Comparison with Civilian Operations

The magnitude of these savings that are produced by construction of facilities under the ready foods concept and that are staffed and operated similarly to modern nonmilitary facilities makes comparison with data from civilian facilities necessary to validate the feasibility of the desired goals. As can be seen in Table 28, present military food service systems operate at higher costs and slightly lower productivity than comparable nonmilitary facilities. The proposed systems designed under the new concepts of operation are projected to operate with total costs and productivities similar or less than those of the average nonmilitary dietary department. The major differences in this Table are explained by the fact that:

TABLE 27

**Projected Costs of the Ready Foods Concept Compared with
the Current System**

Beds	100	250	550
Meals/Month	23,403 ^a (22,192) ^b	36,505 (39,368)	78,015 (74,480)
% Patient Meals	58 (39)	64 (55)	81 (61)
% Patient on Special Diets	22 (16)	24 (25)	30 (45)
% Patient Ambulatory	11 (18)	17 (15)	22 (18)
Manhours/Meal	0.35 (0.27)	0.39 (0.23)	0.29 (0.21)
Labor Cost/Meal	3.13 (1.45)	2.76 (1.26)	2.36 (1.18)
Cost/Meal	4.40	4.03	3.55
Staff			
Supervisors	10 (5)	13 (7)	21 (9)
Cooks	15 (3)	16 (4)	24 (6)
Food Service Workers	28 (19)	37 (25)	96 (44)
Storeroom Workers	2 (1)	3 (1)	10 (3)
Meat Cutters	2 -	2 (1)	3 (2)
Bakers	2 -	2 (1)	2 (2)
Diet Aids	3 (2)	5 (7)	15 (16)
Clinical Dieticians	3 (2)	3 (3)	9 (6)
Other	3 (3)	5 (3)	20 (4)
Total	66 (35)	84 (52)	197 (92)
Reduction In:			
Personnel	31 (47%)	32 (38%)	60 ^c (30%)
Labor Costs ^d	\$448	\$709	\$1055
Food Costs ^e	6	11	20
Equipment Costs ^b	(+12)	(+28)	(+56)
Construction Costs ^b	(+5)	(+10)	(+16)
Energy Costs	(+2)	(+4)	(+8)
Overall Cost Reduction	\$435	\$678	\$995
Maximum Reduction	35%	34%	30%

^aFrom operating data of Summer 1977 (Appendix G)

^bFrom Concept Analysis

^cCorrected for Teaching Function

^dComparison of costs of Summer 1977 with projected costs

^eNew concept could reduce food production waste up to 10%. A value of 25% is used.⁴⁶

⁴⁶Gordon A. Friesen International, Inc., "The Ready Foods System," published by Institutions/Volume Feeding Magazine, Chicago, IL., 1973.

TABLE 28

Comparison of Non-Military and Military Food Services

	NON-MILITARY		MILITARY		
	200-399	300-399	Conventional Concept	Frozen Ready Concept	Present Operations ^b
Bed Size	200-399	300-399	250	250	250
% Patient Meals	64	63	55	55	47
Man Hours/Meal	0.35	0.29	0.26	0.23	0.40
Labor as % of Total Cost	51	47	54	50	68
Labor Cost/Meal	1.28	1.07	1.48	1.25	2.76
Total Cost/Meal	2.58	2.29	2.72	2.48	4.03

^aAHA, Hospital Administration Services, Six-Month Report, National Group 940 and, Census Division 1, Group 1606 - 200 thru 399 bed, June, 1977.

^bOperating Data, Summer 1977 (See Appendix G).

1. Military and civil service labor is significantly more costly resulting in a higher proportion of labor costs.

2. In general, the average AHA facility does not operate using labor saving advance preparation methods, so their average productivity is lower.

3. The overall productivity for the ready foods system should be better than the average civilian facility which does not have as much labor saving equipment.

4. The ready foods concept developed for the MTF should result in a facility with comparable total costs, as higher labor costs are balanced by increased productivity from the additional equipment.

Conclusions

On the basis of both cost and systems effectiveness, all the new concepts for Army Hospital Food Service are superior to the current concept of operation. The resulting relative worth values reflect the increased utility of these concepts with increases over the existing concept of 67, 94, 108, and 146 percent for the improved conventional, the convenience, the cook-chill, and the ready foods concepts, respectively. From these results, the use of a system designed from a ready foods (cook-freeze) concept of operation is the preferred choice for new Army MTF food service. The improved conventional concept, which uses new staffing guidance and insulated patient tray service, or a cook-chill designed system follow as second choices based on their increased worths. The use of a convenience foods system, which has the smallest increase in relative worth due to a small increase in systems effectiveness and the highest overall cost per meal, is not indicated.

The anticipated reductions in operating cost indicated by the economic analysis of these concepts can be seen to be reasonable by comparison to levels of cost now being achieved in nonmilitary hospital food service operations. Thus, implementation of the new concept of operation in the construction of Army hospital food services should result in overall reductions in operating costs of about 30%.

SECTION VI

Ready Foods System Concept

Introduction

On the basis of the detailed analyses presented, the preferred concept selected in terms of cost effectiveness and relative worth is the ready foods system. The design of new food service operations based on the ready foods concept best meets the long term objectives of Army hospital food service. It provides substantial reductions in manpower and costs by affecting those operations (e.g., food production and ward delivery) which are currently very labor-intensive, greater than 60% of the workload. At the same time, this concept eliminates the difficulties of supplying the ward patient with hot foods which are adversely affected by heat maintenance delivery systems.

As already discussed in Section V, it also offers other, less readily quantifiable advantages:

1. Increased manageability and efficiency in personnel utilization.
2. Improved quality control.
3. Greater ease and economies in producing special diet meals using larger batches.
4. Increased menu selection.
5. Greatest flexibility to adjust to high workloads and compatibility with other concepts.
6. Facilitated ingredient room control (i.e., higher quality and lower costs).
7. General reduction in skilled labor requirements, and
8. Reduction in food waste.

Food Preparation

The heart of the ready foods concept is the kitchen where the food product is prepared, packaged, frozen, stored, tempered, and prepared for delivery to the consumers. The concept of operation, the critical areas, the system flow (Figure 4), the resource requirements, and the overall system configuration (Table 4) were discussed in Section III. Layouts representing possible floor plans for this concept as they would derive from the earlier discussions are shown in Figures 10, 11, and 12.

The receiving and storage operations in a ready foods system differ little from the conventional operation. Foodstuffs, received in larger individual quantities than with the

conventional concept, are placed in appropriate storage areas to await processing. As with the conventional system, processing begins with preparation of vegetables and meats and continues in the ingredient room where careful selection and measurement of ingredients assures consistent product quality and reduces waste. Each component is packaged, labeled, and assembled with the other recipe ingredients for pickup and continued processing by the cooks and other food service workers.

Production of ready foods is in support of an inventory rather than daily demand, therefore, production scheduling becomes a more vital function. Large batches make maximum utilization of equipment and labor during each working day. This function may be facilitated by available computer production and inventory programs. Conventional preparation, which might involve the production of thirty or more items a day, can be reduced to production of five or less larger sized batches. Large batches are produced about one week in advance, and smaller batches on a 30- to 60-day inventory basis; an average 15-day dwell for frozen items in the holding freezer.

As each batch finishes cooking, the food is portioned hot into bulk and, in certain cases, individual containers, and sealed. Packaged food items are immediately freeze-processed at -50°F (45°C), labeled, and stored in the holding freezer at approximately -10°F (-12°C). Although ready foods generally have a shelf life of three to six months, freezer storage time is minimized by careful first-in, first-out inventory control to conserve valuable freezer storage space and insure product quality.

Eight to twenty-four hours before service the frozen foods are thawed under carefully controlled conditions (i.e., tempered) in a tempering box. Thawed foods, unlike frozen, can be rapidly and evenly reheated. For dining hall use the food is reheated in bulk containers using convection ovens.

Patient meals are treated differently. The use of chilled food under a ready foods concept provides additional advantages. Unlike conventional patient tray service, where hot and cold food must be transported using some technique of heat maintenance in an attempt to insure optimum palatability, the ready foods are transported in their less perishable chilled state using special reheating carts. This allows the centralized assembly of the individual patient tray to proceed at a slower pace, involving fewer personnel and less equipment, and also allows the reheating of meals on patient demand. Since food need not be held at service temperature or reheated more than once, the deterioration caused by conventional heat maintenance cart systems is eliminated. Thus, the completely assembled tempered meals on trays are collated onto carts in the assembly area, transported chilled to the ward area, maintained under controlled refrigeration on the ward, where, immediately before service, hot foods are automatically reheated in the transport carts with the cold items remaining refrigerated. After the heating cycle is completed, the ready tray is removed from the cart, and the hot beverages, as necessary, added, for delivery of the complete tray to the patient.

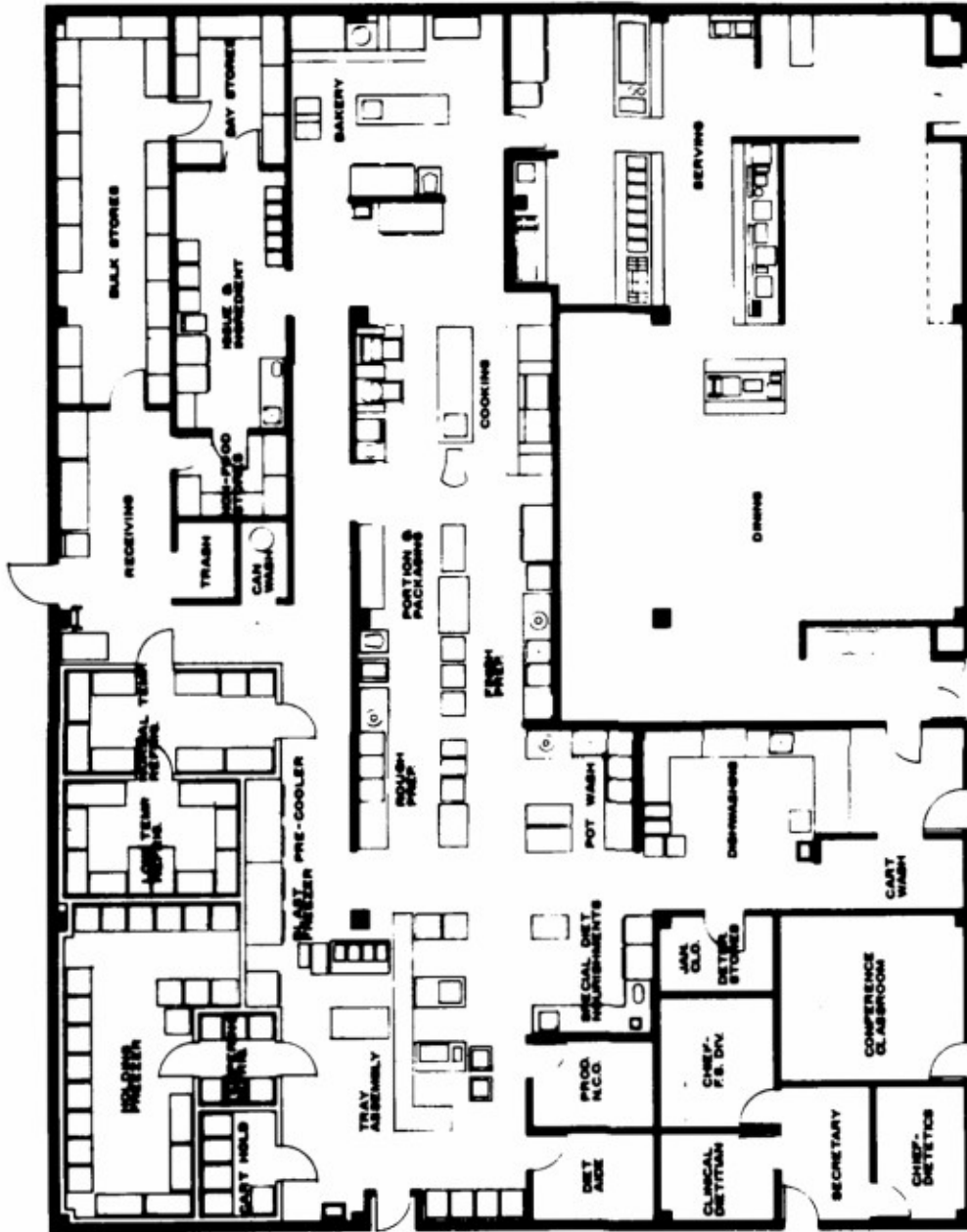

100 BEDS



Figure 10. Kitchen and Dining Hall Layout — 100-Bed

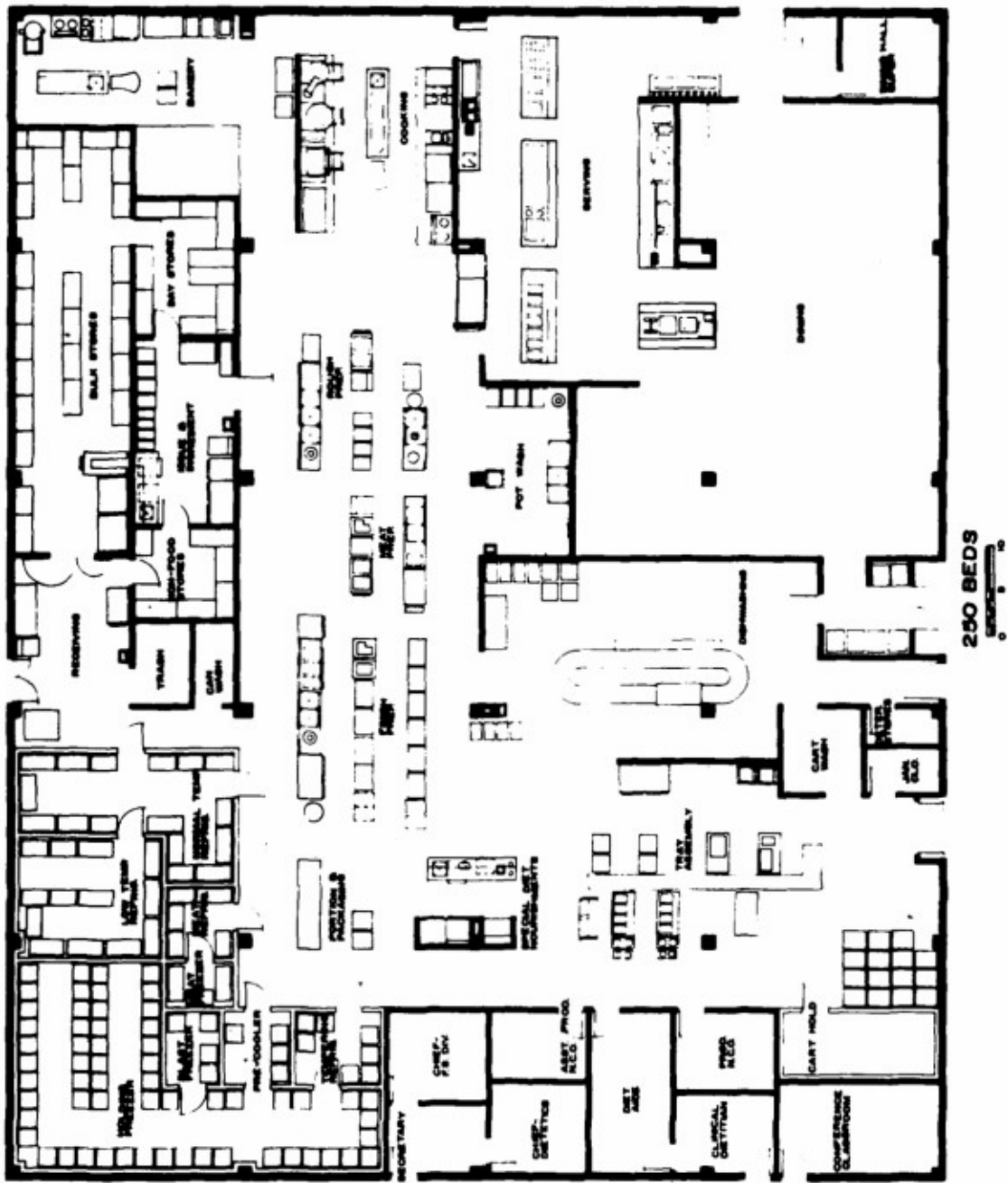

Figure 11. Kitchen and Dining Hall Layout - 250-Bed

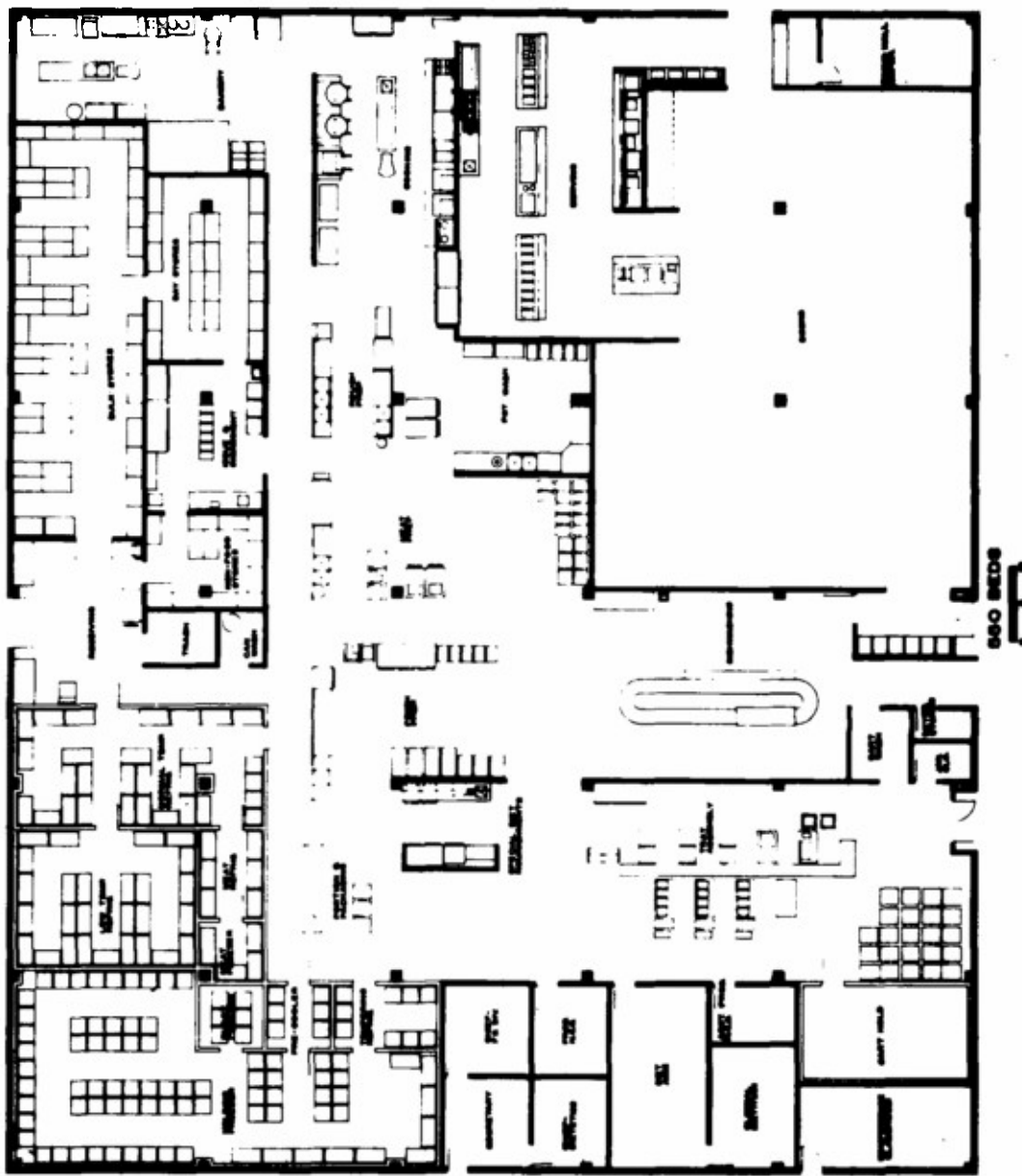

Figure 12. Kitchen and Dining Hall Layout - 500-Bed

As discussed in Section IV, the choice of a reheating oven need not significantly effect the performance or cost of the preferred alternative, so long as it is integral to the delivery system and allows reheating without tray disassembly. The criteria for choice of an oven, then, depends on the complexity of the tray preparation operation and other human factors considerations. In any case, the choice of the cook-freeze alternative with any oven option offers the best mix of advantages.

Ward Dining Concept

The largest portion of the patient population eat their meals in the hospital ward area. In many facilities the main dining hall of the hospital is available to ambulatory patients. However, ill or weak patients are often unwilling or unable to leave the ward area for meals. The ward dining concept, as an alternative to eating in the hospital room, is expected to offer substantial therapeutic benefits, while improving the acceptability of patient food service.

Group dining and its therapeutic effect on patients has been evaluated by Ronco⁴⁷, who found it supports the medical objective of the patient becoming ambulatory as soon as possible. Other factors of the group dining experience, like social interaction, stimulation, and self-confidence, are all necessary to the patient, and impact favorably on the rate of recovery.⁴⁸⁻⁵³ Additionally, the physical environment plays an important interactive role in the recovery rate of patients. In particular, sensory deprivation is linked to an increase in stress levels of patients which prolongs their recovery rate.⁵⁴ Group dining provides relevant sensory experiences (especially seeing, feeling, hearing), which have been shown to decrease the trauma of hospitalization and speed recovery.⁵⁵ The ward dining area would function as an organizing principle around which the patients can structure their behavior.⁵²⁻⁵⁶

⁴⁷Ronco, P. G., "Human Factors Applied to Hospital Patient Care", *Human Factors*, 14, 461 (1972).

⁴⁸Aylward, G. M., "Towards a Theory for Describing and Designing Adaptability in the Built Environment," *Transactions Bartlett Society*, 7, 129 (1969).

⁴⁹Birren, F., "The Rational Approach to Colour in Hospitals," *The Hospital*, 17, 656 (1961).

⁵⁰Madge, J., "Privacy and Social Interaction," *Transactions Bartlett Society*, 3, 121 (1965).

⁵¹Rogers, P. S., "Design for Patient Care," *International Nursing Review*, 19, 267 (1972).

⁵²Spivack, M., "Hospitalization, Time Without Purpose," *Ergonomics*, 41, 200 (1976).

⁵³Wohlwill, F., "The Physical Environment: A Problem for a Psychology of Stimulation,"

Several dayroom dining area designs, Appendix I, have been developed as alternative modes of ward dining. By utilizing space already allocated to other patient social functions, the ward dining concept can be implemented without requiring any additional expensive hospital space.

J. of Social Issues, 22, 29 (1961).

⁵⁴West, N. D., "Stresses Associated With ICU's Affect Patients, Families, Staff," *Hospital*, 49, 62 (1974).

⁵⁵Markowitz, R., "Adventures in a Pediatric Unit," *Ibid.*, 48, 63 (1974).

⁵⁶Arneill, B. P., "Guidelines for Design of Facilities," *Ibid.*, 49, 83 (1975).

LIST OF REFERENCES

- American Hospital Association, Hospital Services Report, National Group 190, 1st Quarter 1976, and National Group 940 1st Quarter 1976 and 1st half 1977.
- AR 40-2, "Army Medical Treatment Facilities, General Administration," Headquarters, Department of the Army, Washington, DC, July 1975.
- AR 415-17, "Emperical Cost Estimatas for Military Construction and Cost Adjustment Factors," HQ, Department of the Army, Washington, DC, 9 August 1976.
- Arneill, B. P., "Guidelines for Design of Facilities," *Hospitals*, 49, 83 (1975).
- Aylward, G. M., "Towards a Theory for Describing and Designing Adaptability in the Built Environment," *Transactions Bartlett Scoeity*, 7, 129 (1969).
- Birren, F., "The Rational Approach to Colour in Hospitals," *The Hospitel*, 17, 656 (1961).
- Carpentar, L., H. C. Abraham, G. T. King, "Tenderness and Cooking Loss of Beef and Pork," *J. Amer. Dietetic Assoc.*, 53, 353 (1968).
- Clegg, C. A. and A. M. Crowley, "Reheating Frozen Entrees," *Hospitals*, 46, 90 (1972).
- Clemence, E., "The Mystery and Mastery of Microwave," *Dimensions in Health Service*, 53, 32 (1976).
- Cost and Operational Effectiveness Analysis Handbook, USA Training and Doctrine Command, Pamphlet 11-8, Ft. Monroe, VA 23651.
- Dixon, W. J., *BMDP: Biomedical Computer Programs*, University of California Press, Berkeley, 1975.
- Eheart, M. S. and C. Gott, "Conventional and Microwave Cooking of Vegetables," *J. Amer. Dietetic Assoc.*, 44, 116 (1964).
- Ellis, C., "Old New Meld in Ready Foods System," *Modern Health Care*, 6, 41 (1976).
- Food Service Division, Brook Army Medical Center, "Staff Study on Food Service to Patients on Nursing Units," August, 1976.
- Fries, J. A. end D. M. Grahem, "Reconstituting Preplated Frozen Maals with Integral Heet," *Food Tech*, 26, 76 (1972).
- Gordon A. Friesen Internationel, Inc., "The Raady Foods System," published by Institution/Volume Feeding Magazine, Chicago, IL., 1973.

Herz, M. L., et.al., "Analysis of Alternative Patient Tray Delivery Concepts," Tech Report, NATICK/TR-78/013, September, 1977, (AD A052494).

Hitchcock, M. J., I. Noble and S. Thourd, "Effect of Holding on Broccoli Prepared in Volume," J. Amer. Dietetic Assoc., 49, 418 (1966).

HSC Progress Summary, Ft. Sam, Houston, TX, 3rd Quarter 1977.

HSC Progress Summary, Ft. Sam, Houston, TX, 4th Quarter 1975.

Hysen, P., "Ready Foods May Provide Ready Savings," Modern Hospitals, 116, 95 (1971).

Kaird, F. A., "Implementing the Chilled Food Concept," Hospitals, 46, 97 (1972).

Kirk, R. E., "Experimental Design: Procedures for the Behavioral Sciences," Brooks/Cole, Belmont, Cal, 1968.

Kylen, A. M., B. H. McGrath, E. L. Hallmark, F. O. Van Dwyne, "Microwave and Conventional Cooking of Meat," J. Amer. Dietetic Assoc., 45, 139 (1964).

Kylen, A. M., V. R. Charles, B. H. McGrath, J. W. Schleter, L. C. West, and F. O. Van Dwyne, "Microwave Cooking of Vegetables," J. Amer. Dietetic Assoc., 39, 321 (1961).

Lord, Frederick M., and Melvin R. Novick with Alan Birnbaum, "Statistical Theories of Mental Test Scores," Addison-Wesley Publishing Co., Reading, MA, 1974, p. 87.

Madge, J., "Privacy and Social Interaction," Transactions Bartlett Society, 3, 121 (1965).

Markowitz, R., "Adventures in a Pediatric Unit," Hospitals, 48, 63 (1974).

McIver, C., "Batch Cooking," Hospitals, 44, 94 (1970).

Merrick, M. and P. J. Sutton, "The Minimal Cooking Concept," Hospitals, 46, 92 (1972).

Nie, Norman H., SPSS: Statistical Package for the Social Sciences, McGraw Hill, New York, 1975.

Office of Commercial/Industrial Sales, Boston Edison Co., Boston, MA, Summer, 1977.

Peryam, D. R., and F. J. Pilgrim, "Hedonic Scale Method of Measuring Food Preferences," Food Technology, 11, 9 (1957).

Pinkert, M. S. and P. Hysen, "Pros and Cons of Three Food Systems," Canadian Hospital, 50, 13 (1973).

Pinkart, M. S., "Basic Planning Concepts for Ready Foods Systems," *Canadian Hospital*, 49, 32 (1972).

Rainsford, P., "A Study Comparing the Financial, Managerial, and Reconstitution Differences between Conventional and Convenience Food Service Systems Utilized by Selected Colleges, Universities and Hospitals," Ph.D. Thesis, Cornell University, Ithaca, New York. 1974.

Riglay, E., "An Overview of Food Service Systems," *Dimensions in Health Service*, 51, 42 (1974).

Rogers, P. S., "Design for Patient Care," *International Nursing Review*, 19, 267 (1972).

Rogozenski, J. E. and H. R. Moskowitz, "A System for the Preference Evaluation of Cyclic Menus," Tech Report NATICK/TR-75/46-OR/SA, October, 1974, (AD A005158).

Ronco, P. G., "Human Factors Applied to Hospital Patient Care," *Human Factors*, 14, 461 (1972).

Schirmer, W. E., "Convenience Foods System Saves Labor, Money," *Hospitals*, 46, 110 (1972).

Schnaider, R. F., "In-House Production Capacity Proves Effective," *Hospitals*, 48, 71 (1974).

Silvin, R. R., "Community and Commercial Usage of the Ready Foods System," *Canadian Hospital*, 50, 30 (1972).

Spivack, M., "Hospitalization, Time Without Purpose," *Ergonomics*, 41, 200 (1976).

Trueman, R. F., "A Systems Approach to Reconstitution Equipment," *Canadian Hospital*, 49, 71, June, 1972.

Tuomy, J. M. and G. C. Walker and Hinnergardt, "Pilot Plant Evaluation of Frozen Entree Items for the Navy," Tech Report NATICK/TR-76/31-FEL, September, 1976, (AD A03132).

Walker, G. C. and J. M. Tuomy, "Evaluation of Frozen Meat Entrees," Tech Report, NATICK/TR-77/24-FEL, October, 1974, (AD A000680).

Walker, G. C., J. M. Tuomy, and C. G. Kanter, "Egg Products for Use in a Cook-Freeze System," Tech Report, NATICK/TR-76/28-FEL, August, 1976, (AD A031023).

West, N. D., "Stresses Associated With ICU's Affect Patients, Families, Staff," *Hospital*, 49, 62 (1974).

Williamson, B. J., "Tomorrows System - The Food Factory - Today," *Perspective in Practice*, 66, 499 (1975).

Winer, B. J., "Statistical Principles in Experimental Design," McGraw Hill, New York, 1962.

Wohwill, F., "The Physical Environment: A Problem for a Psychology of Stimulation," *J. of Social Issues*, 22, 29 (1961).

APPENDIX A
Labor Requirements

TABLE A-1
LABOR COSTS - 100 BEDS

	Improved Conventional		Convenience		Cook-Chill (Bulk)		Ready Foods (Bulk)	
	P	L	P	L	P	L	P	L
Administrative Branch Staff	3	\$41,338	3	\$41,338			3	\$41,338
Production and Service Branch Staff								
Subsistence and Supply Section	3	30,066			3	30,066	2	20,044
Receipt Storage & Issue Unit			1	9,797				
Ingredient-Veg. Prep.-Meat Prep. Unit	2	17,452			2	17,452	2	17,452
Preparation & Service Section								
Food Prep. & Pastry Unit	7.6	90,984	4	48,590	6.4	71,133	6.4	71,133
Sanitation Unit	2	15,308	4	30,616	5.6	42,862	5.6	42,862
Patient Tray Service Unit	12.4	104,526	5	43,638	5	42,930	5	43,638
Dining Hall	5	41,810	7	58,534	7	58,534	7	58,534
Diet Therapy Branch Staff	5	51,706	5	51,706	5	51,706	4	43,804
Total	40	\$393,190	29	\$284,219	37	\$356,021	35	\$338,805
Cost/FTE		\$9,830		\$9,800		\$9,622		\$9,680
Meals/Manhour		0.31		0.23		0.29		0.27

P = Number of Personnel

L = Labor Costs

TABLE A-2
STAFFING REQUIREMENTS - 100 BEDS

Position	Grade	Improved Conventional		Convenience		Cook-Chill (Bulk)		Ready Foods (Bulk)	
		P	L	P	L	P	L	P	L
Administrative Staff									
Chief	O-3	1	\$20,482	1	\$20,462	1	\$20,462	1	\$20,462
Admin. Sec.	GS-04	1	8,870	1	8,870	1	8,870	1	8,870
NCOIC	E-6	1	12,006	1	12,006	1	12,006	1	12,006
Production Staff									
Warehouseman	WG-5		-	1	9,787		-		-
Veg. Prep./Issue Wks.	WG-4	1	9,090		-	1	9,090	1	9,090
Veg. Prep. Wks.	WG-3	1	8,362		-	1	8,362	1	8,362
Issue/Ingredient	WG-3				-				
Prod./Svc Assist NCO - Preparation & Service	E-5	3	30,066		-	3	30,066	2	20,044
First Cook Gen. Spec.									
Diets	WS-7	2	30,410	2	30,410	1	15,205	1	15,205
Cook	1WL-8, WG-8	3	36,940		-	2	25,022	2	25,022
Cook Helper	WG-4	1.6	14,544	1	9,090	1.4	12,726	1.4	12,726
Sandwich/Salad WK	WG-4	1	9,090	1	9,090	2	18,180	2	18,180
Sanitation									
Pot Washing	WG-2	1	7,654	1	30,616	1.4	42,862	1.4	42,862
Dishroom	WG-2	1	7,654	2		2.8		2.8	
Tray Assembly									
Tray Assembly	2WL-4, WG-3	8	78,502	3	28,330	2	19,968	3	28,330
Tray Delivery	WG-2	3.4	26,024	2	15,308	3	22,862	2	15,308
Dining Hall	WG-3	5	41,810	7	58,534	7	58,534	7	58,534
Diet Therapy Branch									
Chief of Dietetics	O-2	1	16,328	1	16,328	1	16,328	1	16,328
Clinical Dietitian	O-1	1	11,672	1	11,672	1	11,672	1	11,672
Diet Aids	GS-3	3	23,706	3	23,706	3	23,706	2	15,804
Total		40	\$393,180	29	\$284,218	37	\$356,021	35	\$338,805
Avg.			\$ 8,830		\$ 8,801		\$ 9,622		\$ 9,680

P = Number of Personnel

L = Labor Costs

TABLE A-3

LABOR COSTS - 260 BEDS

	Improved Conventional		Convenience		Cook-Chill (Bulk)		Ready Foods (Bulk)	
	P	L	P	L	P	L	P	L
Administrative Branch Staff	3	\$49,962	3	\$49,962	3	\$49,962	3	\$49,962
Production & Service Branch Staff	3	36,018	-	-	3	36,018	2	24,012
Subsistence & Supply Section								
Receipt Storage Issue Unit	1	20,462	3	49,485	2	29,023	2	29,023
Ingredient-Veg. Prep.-Meat Prep. Unit	3	28,871	2	18,180	3	28,871	3	28,871
Preparation & Service Section								
Food Prep. & Pastry Unit	10	110,660	4.4	50,656	8	87,622	7	75,704
Sanitation Unit	2	15,308	6	45,924	7	53,578	7	53,578
Patient Tray Service Unit	21	176,014	8.4	68,258	8.6	69,789	8.6	69,789
Dining Hall	9	78,502	8.2	71,812	8.4	73,485	8.4	73,485
Diet Therapy Branch Staff	8	92,628	11	124,760	11	124,760	11	124,760
Total	60	\$608,425	46	\$479,037	54	\$553,108	52	\$529,184
Cost/FTE		\$ 10,140		\$ 10,414		\$ 10,242		\$ 10,177
Meals/Manhour		0.26		0.20		0.24		0.23
Manhours/Meal								

P = Number of FTE Personnel

L = Labor Costs

TABLE A-4

STAFFING REQUIREMENTS - 250 BEDS

Position	Grade	Improved Conventional		Convenience		Cook-Chill (Bulk)		Ready Foods (Bulk)		
		P	L	P	L	P	L	P	L	
Administrative Staff										
Chief	0-4	1	\$24,388	1	\$24,388	1	\$24,388	1	\$24,388	
Admin. Sec.	GS-4	1	6,870	1	8,870	1	8,870	1	8,870	
Clerk Typist			-		-		-		-	
NCOIC	E-8	1	16,704	1	18,704	1	18,704	1	18,704	
Production Staff										
Prod/Svc Chief	0-3	1	20,462	2	40,924	1	20,462	1	20,462	
Warehouse										
Supervisor	E-4		-	1	8,561	1	8,561	1	8,561	
Veg. Prep./Issue Leader	WL-4	1	8,984		-	1	8,984	1	8,984	
Veg. Prep. Workers	WG-4	1	8,090	2	18,180	1	8,090	1	9,090	
Issue/Ing. Wks.			-		-		-		-	
Meat Cutter			-		-		-		-	
Meat Cutter Helper	WG-5	1	8,787		-	1	9,787	1	9,797	
Prod./Svc Ass. NCO -										
Prep. & Service	E-6	3	36,018		-	3	36,018	2	24,012	
First Cook	WL-8	1.4	18,348	1	13,104	1	13,104	1	13,104	
Cook	WG-8	2.8	33,370	2	23,836	2	23,836	1	11,818	
Cook Helper	WG-8	2	21,008		-	1.4	14,706	1.4	14,706	
Sandwich/Salad WK	WG-5	2.8	27,432	1.4	13,716	2.8	25,472	2.6	25,472	
Baker Helper	WG-8	1	10,504		-	1	10,504	1	10,504	
Sanitation Use Tray Del. Staff										
Pot Washing	WG-2		-		-	3	22,962	3	22,962	
Dishroom	WG-2	2	15,308	5	45,924	4	30,616	4	30,616	
Tray Assembly	2WL-4, 15 WG-3 (Conv't)									
	WG-3 (All Others)	17	145,398	5.6	46,827	5.5	46,627	5.6	46,827	
Tray Delivery	WG-2	4	30,816	2.8	21,431	3	22,962	3	22,962	
Dining Hall Wks	2WL-4, WG-3	9	78,502	8.2	71,812	8.4	73,485	8.4	73,485	
Diet Therapy Branch										
Chief	0-3	1	20,462	1	20,462	1	20,462	1	20,462	
Clinical Dietitians	0-2	2	32,656	3	48,984	3	48,984	3	48,984	
Diet Aids	GS-3	5	39,510	7	55,314	7	55,314	7	55,314	
Total		60	\$608,425	46	\$478,037	54	\$553,108	52	\$529,184	
Avg Salary			\$ 10,140		\$ 10,414		\$ 10,243		\$ 10,177	

P = Number of FTE Personnel

L = Labor Costs

TABLE A-5

LABOR COSTS - 550 BEDS

	Improved Conventional		Convenience		Cook-Chill (Bulk)		Ready Foods (Bulk)	
	P	L	P	L	P	L	P	L
Administrative Branch Staff	4	\$63,469	4	\$63,469	4	\$63,469	4	\$63,469
Production and Service Branch Staff	3	43,035	3	43,035	3	43,035	2	28,690
Subsistence & Supply Section								
Receipt & Storage Issue Unit	4	63,755	2	38,906	4	63,755	4	63,755
Ingredient-Veg. Prep.-Meat Prep. Unit	6	60,091	1	9,090	6	61,527	6	60,091
Preparation & Service Section								
Food Prep. & Pastry Unit	19	209,725	6	60,196	17	184,703	15	161,998
Sanitation Unit	3	22,962	11	84,194	13	99,502	12	91,848
Patient Tray Service Unit	39	319,746	16	129,544	16	129,544	16	129,544
Dining Hall	9	78,502	11	95,226	11	95,226	11	95,226
Diet Therapy Branch Staff	16	185,048	22	232,460	22	232,460	22	232,460
Total	103	\$1,046,333	76	\$756,120	96	\$973,221	92	\$927,081
Cost/FTE		\$10,158		\$9,949		\$10,138		\$10,077
Meals/Manhour		0.24		0.18		0.22		0.21
Manhours/Meal								

P = Number of FTE Personnel

L = Labor Costs

TABLE A-6

STAFFING REQUIREMENTS - 550 BEDS

Position	Grade	Improved Conventional		Convenience		Cook-Chill (Bulk)		Ready Foods (Bulk)		
		P	L	P	L	P	L	P	L	
Administrative Staff										
Chief	0-5	1	\$28,940	1	\$28,940	1	\$28,940	1	\$28,940	
Administrative Sec.	GS-5	1	9,923	1	9,923	1	9,923	1	9,923	
Clerk Typist	GS-3	1	7,902	1	7,902	1	7,902	1	7,902	
NCOIC	E-8	1	16,704	1	16,704	1	16,704	1	16,704	
Production Staff										
Production/Svc Chief	0-4	1	24,388	1	24,388	1	24,388	1	24,388	
Ass. NCO-Subsistence/Supply Warehouse	E-7	1	14,345		-	1	14,345	1	14,345	
Supervisor	WS-9	1	14,518	1	14,518	1	14,518	1	14,518	
Warehouseman	WG-6	1	10,504		-	1	10,504	1	10,504	
Veg. Prep./Issue Leader	WL-4	1	9,984		-	1	9,984	1	9,984	
Veg. Prep. Workers	WG-2	2	15,308		-	1	7,654	2	15,308	
Issue Ing. Wrk	WG-4	1	9,090	1	9,090	2	19,180	1	9,090	
Meatcutter	WS-9	1	15,912		-	1	15,912	1	15,912	
Meatcutter Helper	WG-5	1	9,797		-	1	9,797	1	9,797	
Ass. NCO-Prep. & Service	E-7	3	43,035	3	43,035	3	43,035	2	28,690	
First Cook	WS-6	2	29,036		-	1	14,519	1	14,519	
Cook	WG-8	4	47,672		-	4	47,672	2.8	33,370	
Cook Helper	WG-5	5	52,520	2	21,008	4	42,019	3.2	33,613	
Sandwich/Salad Wrk	WG-5	6	58,782	4	39,188	6	58,782	6	58,782	
Baker	WG-8	1	11,918		-	1	11,918	1	11,918	
Baker Helper	WG-5	1	9,797		-	1	9,797	1	9,797	
Sanitation Wk Trayline Cover	WG-2		-	2		3.2		2.2		
Potwashing	WG-2		-	1	84,194		99,502		91,848	
Dishroom	WG-2	3	22,962	8		9.8		9.8		
Tray Assembly	WG-3	30	250,860	10	83,620	10	93,620	10	83,620	
Tray Delivery	WG-2	9	68,889	9	45,924	6	45,324	6	45,924	
Dining Hall Wks	2WL-4, WG-3	9	76,502	11	95,226	11	95,226	11	95,226	
Diet Therapy Branch										
Chief	0-4	1	24,388	1	24,388	1	24,388	1	24,388	
Clinical Dietitian	0-2	5	81,640	5	81,640	5	81,640	5	81,640	
Diet Aids	GS-3	10	79,020	16	126,432	19	126,432	16	126,432	
Total		103	\$1,046,333	76	\$756,120	96	\$973,221	92	\$927,081	
Avg Salary			\$10,159		\$9,949		\$10,138		\$10,077	

P = Number of FTE Personnel

L = Labor Costs

APPENDIX B

Food Costs

Food Costs

The current average food cost for Army hospitals is \$1.13 per meal (Appendix G), which would result in annual costs of:

- a. 100 beds; $\$1.13 \times 730 \text{ meals/day} \times 365 \text{ days/year} = \$301,089$
- b. 250 beds; $\$1.13 \times 1295 \text{ meals/day} \times 365 \text{ days/year} = \$534,123$
- c. 550 beds; $\$1.13 \times 2450 \text{ meals/day} \times 365 \text{ days/year} = \$1,010,503$

A representative menu was prepared and costed for both the conventional and convenience systems (Table B-1). Costs of the conventional food items are representative commercial prices, and costs of convenience foods are represented by the prices charged by Armour and Campbell. This comparison shows that the food cost of an 80% convenience system is 47% greater than for the conventional system. An evaluation of the total convenience system at Franklin Square Hospital, Baltimore, MD, yielded similar results. The food cost at Franklin Square was \$1.58 per meal. The raw food costs for Franklin Square's menu, estimated using the computerized item price list at Fairfax Hospital, Falls Church, VA, were \$0.91 per meal. Thus, the food cost per meal of an 80% convenience system is:

$$\$0.91 (0.2) + \$1.58 (0.8) = \$1.45$$

or 59% higher than the conventional system costs. Based on these results, a 50% increase in convenience food costs is assumed.

TABLE B-1
REPRESENTATIVE MENUS – CONVENTIONAL VS 80% CONVENIENCE

Breakfast		
	Conventional	80% Convenience
Juice	\$0.07	\$0.08
Cereal with Milk (Cold)	.12	.12
Donut	.04	.04
Eggs (Omelette)	.10	.31
Coffee	.06	.06
Bacon or Sausage (3 Strips)	<u>.15</u>	<u>.18</u>
TOTAL	\$.54	\$.85
Lunch		
Potato (Instant Mashed/Gravy)	\$.04	\$.04
Soup – Canned	.08	.08
Entree (Average of 10 Entrees)	.31	.51
Vegetable	.09	.09
Jello Salad with Fruit	.07	.13
Dessert (Pie or Cake)	.11	.23
Milk – ½Pint Container	.09	.09
Bread and Butter	<u>.04</u>	<u>.09</u>
TOTAL	\$.83	\$1.32
Dinner		
Entree	\$.41	\$.75
Potato (Other than Instant)	.06	.12
Vegetable	.09	.09
Tossed Salad with Dressing	.06	.11
Dessert – Pudding	.07	.11
Bread and Butter	.04	.09
Milk	.09	.09
Coffee	<u>.06</u>	<u>.06</u>
TOTAL	\$.88	\$1.42
Patient Meal Cost	\$2.25	\$3.59
Condiments (Jelly-Coffee-Cream- Syrup-Catsup)	.20	.20
Nourishments (Canned Drink- Cookies-Coffee, etc)	.40	.40
Daily Food Cost	\$2.85	\$4.19
Cost/Meal	\$.95	\$1.40

APPENDIX C
Equipment Lists

TABLE C-1
AREA EQUIPMENT COSTS – 100 BEDS

	Improved Conventional	Convenience	Cook-Chill (Bulk)	Ready Foods (Bulk)
Receiving & Shipping	\$ 3,350	\$ 3,350	\$ 3,350	\$ 3,350
Trash	450	450	450	450
Bulk Stores	2,100	1,820	2,100	2,100
Day Stores & Non Food Stores	1,260	1,120	1,260	1,260
Issue & Ingredient Area	8,750	–	8,850	8,850
Rough Preparation	4,460	4,155	4,460	4,460
Refrigeration	22,600	43,500	45,500	71,300
Cold Preparation Area	13,000	12,350	13,000	13,000
Special Diet/Nourishment Station	7,190	7,190	7,190	7,190
Hot Preparation Area	63,750	28,250	58,600	58,600
Baking & Pastry	13,700	2,900	13,700	13,700
Warewashing	18,200	18,200	19,050	19,050
Portioning & Packaging	–	–	2,300	2,300
Patient Tray Assembly	22,750	13,500	13,500	13,500
Dining Hall Service	64,350	66,350	66,350	66,350
40 Bed Galley Area	18,000	68,000	68,000	68,000
GRAND TOTAL	\$263,910	\$271,135	\$326,660	\$353,460

TABLE C-2

Equipment List - 100 Beds

	Improved Conven- tional		Convenience		Cook Chill (Bulk)		Ready Foods (Bulk)	
Receiving & Shipping Area								
1. Printing Floor Scala	1	\$ 2300	1	\$ 2300	1	\$ 2300	1	\$ 2300
2. Dock Leveler	1	-	1	-	1	-	1	-
3. Table, Inspection (3'x6'x30")	1	300	1	300	1	300	1	300
4. Platform Hand Truck (30"x48")	1	400	1	400	1	400	1	400
5. Desk & Chair	1	-	1	-	1	-	1	-
6. Hand Sink	1	250	1	250	1	250	1	250
7. Hand Cart	1	100	1	100	1	100	1	100
Subtotal		\$ 3350		\$ 3350		\$ 3350		\$ 3350
Trash Area								
1. Can Crusher	-		-		-		-	
2. Compector or Bulk Haul-Off Cont.			Shared W/Hospital Waste Handling					
3. Staging Refrigerator	-		-		-		-	
4. Can Washer	1	450	1	450	1	450	1	450
Subtotal		\$ 450		\$ 450		\$ 450		\$ 450
Bulk Stores Area (15 Days @ Ambient)								
1. Shelving (24"x48"x60") (lin ft)	15	2100	13	1820	15	2100	15	2100
2. Desk & Chair	1	-	1	-	1	-	1	-
Subtotal		\$ 2100		\$ 1820		\$ 2100		\$ 2100
Day Stores & Non Food Stores Area								
1. Non Food Shelving	3	420	3	420	3	420	3	420
2. Day Stores Shalving	6	840	5	700	6	840	6	840
Subtotal		\$ 1260		\$ 1120		\$ 1260		\$ 1260
Issue & Ingredient Area								
1. St. Steel Counter W/12" Backsplash (lin ft) W/Self Draining Edge W/18" Sink W/Undershelf Bins W/Drawer	6	750			6	750	6	750
2. Dvershelf (12") (lin ft)	4	100			4	100	4	100
3. Mobile Bins W/Covers	4	600			5	700	5	700
4. Batch Carts - Bakery Rack (18"x26"x60")	4	900			4	900	4	900
5. Shelving (Spices, Sm Food Items) 18" Mobila	3	200			3	200	3	200

TABLE C-2

Equipment List - 100 Beds (cont'd)

	Improved Conven- tional		Convenience		Cook Chill (Bulk)		Ready Foods (Bulk)
Issue & Ingredient Area (cont'd)							
8. Bag Dispenser	1	\$ 150			1	\$ 150	1 \$ 150
7. Portable Electric Can Opener	—				—		—
8. Bench Scale, Table Top, Digital Readout, Metric & Avoirdupois to 12 kg	1	500			1	500	1 500
9. Bench Scale to 225 kg	—				—		—
10. Spice Scale (Portion Scale) - Metric & Avoirdupois to 1 kg	1	300			1	300	1 300
11. Refrigerator, Reach-In (No. of Compartments)	2	2000			2	2000	2 2000
12. Freezer, Reach-In (No. of Compartments)	2	2250			2	2250	2 2250
13. Trash Receptacle	1	50			1	50	1 50
14. Utility Cart	1	200			1	200	1 200
15. Platform Truck (Bulk Stores, Trash)	1	400			1	400	1 400
16. Hand Sink W/Wrist Blade Faucets & Towel & Soap Dispenser	1	250			1	250	1 250
Subtotal		\$ 8750			\$ 8850		\$ 8850
Rough Prep. (Vegetable Prep.) Area							
1. St. Steel Work Counter W/12" Backsplash (lin ft) W/3-Compartment Sink W/Right Drainboard W/Waste Disposal	11	3000	11	\$ 3000	11	3000	11 3000
2. Bench Platform Scale to 12 kg Metric & Avoirdupois	1	500	1	500	1	500	1 500
3. Cart (Bakery Rack)	2	450	1	225	2	450	2 450
4. Ingredient Tubs, Stock & Nest (2 ft ²)	8	160	4	80	8	160	8 160
5. Mobile Shelving for Container Storage 24"x72"h (lin ft)	3	350	3	350	3	350	3 350
Subtotal		\$ 4460		\$ 4155	\$ 4460		\$ 4460
Refrigeration Area							
1. Normal Walk-In Refrigerator (36°F) W/St. Steel Mobile Shelves, Dunnage Racks & Carts (ft ²)	150	9700	110	7500	150	9700	150 9700
2. Low Temperature Walk-In Refrigerator (-10°F) W/St. Steel Mobile Shelving, Dunnage Racks & Carts (ft ²)	140	10800	70	6300	140	10800	140 10800

TABLE C-2

Equipment List - 100 Beds (cont'd)

	Improved Conven- tional		Convenience		Cook Chill (Bulk)		Ready Foods (Bulk)		
Refrigeration Area (cont'd)									
3. Holding Refrigerator (35°F, 3 day)(ft ²)					60	\$ 4300			
Storage Containers						2300			
4. Holding Freezer (-10°F, 15 days)(ft ²)			260	\$18900	40	4000	320	\$21900	
Storage Containers								11700	
5. Blast Freezer, Roll-in (-50°F)					1	2250	2	3250	
Carts					1	250	2	500	
6. Pre Cooler Refrigerator (35°F)					2	2650	2	2650	
Walk-in, Roll-in (Compartments)									
7. Tempering Refrigerator (38°F)									
Roll-in (Compartments)					1	250			
Carts					1	250			
8. Tempering Refrigerator (38°F)									
Walk-in			4	3600			4	3600	
Carts			4	1000			4	1000	
9. Patient Staging Refrigerator (35°F)									
Roll-in (Compartments)	1	\$ 1850	1	1850	1	1850	1	1850	
Carts	1	250	1	250	1	250	1	250	
10. Patient Tray Delivery Cart Holding Refrigerator (36°F) (ft ²)			50	4100	50	4100	50	4100	
Subtotal		\$22800		\$43500		\$45500		\$71300	
Cold Preparation Area -Preportioning									
Salads, Cold Plates, Sandwich Assembly									
1. Steel Counter W/12" Backsplash (lin ft)	11	2800	10	2150	11	2800	1	2800	
W/2-Compartment Sink									
W/Disposal (1 H.P.)									
W/Over & Undershelf									
2. Mobile Work Table (3 to 4 ft)	3	1200	3	1200	3	1200	3	1200	
3. Portioning Conveyor	-		-		-		-		
4. Mobile Supply Cart W/Worktop	3	600	3	600	3	600	3	600	
5. Slicer W/Stand	1	1800	1	1800	1	1800	1	1800	
6. Mixer W/Stand (20 qt)	1	1550	1	1550	1	1550	1	1550	

TABLE C-2

Equipment List - 100 Beds (cont'd)

	Improved Conven- tional		Convenience		Cook Chill (Bulk)		Ready Foods (Bulk)	
Cold Preparation Area (cont'd)								
7. Refrigerator, Reach-In (Compartments)	2	\$ 2100	2	\$ 2100	2	\$ 2100	2	\$ 2100
8. Refrigerator, Walk-In (Included in Normal Temp Allocation)	—		—		—		—	
9. Freezer Reach-In (Compartments)	1	1600	1	1600	1	1600	1	1600
10. Cart (Bakery Reck)	3	600	3	600	3	600	3	600
11. Container Storage Mobile Shelves (lin ft)	4	450	4	450	4	450	4	450
12. Dish Recks or Dollies	2	250	2	250	2	250	2	250
13. Trash Receptacles	1	50	1	50	1	50	1	50
Subtotal		\$13000		\$12350		\$13000		\$13000
Special Diets/Nourishment Station Area								
1. Work Counter W/12" Backsplash (lin ft) W/1 Compartment Sink W/3 Drawers W/Undercounter Shelf	9	1500	9	1500	9	1600	9	1500
2. Overhead 12" Shelf W/Recipe Rail (lin ft)	6	150	6	150	6	150	6	150
3. Blender	1	300	1	300	1	300	1	300
4. Refrigerator, Roll-In (Cart Capacity)	1	1850	1	1850	1	1850	1	1850
5. Refrigerator, Reach-In (Compartments)	2	2100	2	2100	2	2100	2	2100
6. Portion Scale	1	300	1	300	1	300	1	300
7. Microwave Oven	—		—		—		—	
8. Storage Cabinet (lin ft)	3	600	3	500	3	600	3	600
9. Film Dispenser, Wall-Mounted	1	20	1	20	1	20	1	20
10. Disposable Cup Dispenser, Wall-Mount	3	90	3	90	3	90	3	90
11. Label Dispenser, Wall-Mount	1	30	1	30	1	30	1	30
12. Utility Cart, Undercounter	1	200	1	200	1	200	1	200
13. Trash Receptacle	1	50	1	50	1	60	1	50
14. Hand Sink W/Wrist Blade Faucets				Shared				
Subtotal		\$7190		\$7190		\$7190		\$7190
Hot Preparation Area								
1. Range, Conventional (Heating Positions)	2	600			2	600	2	600
2. Range, Hot Top (lin ft)	3	1300						
3. Broiler-Grill Combination (lin ft)	3	1800			3	1800	3	1800
4. Oven, Convection (Compartments)	2	2750	2	1400	2	2750	2	2750
5. Fryer W/Spreaders, Fat Filter	1	1900			1	1900	1	1900
6. Braising Pan	1	2150	1	2150	1	2160	1	2150
7. Steamer, Pressure (Compartments) Kettles, Wall-Mounted, Ball Valve Drain	1	1300	1	1300	1	1300	1	1300
8. 60-Gal Tilt					1	4600	1	4600
9. 40-Gal Tilt	2	8000			1	4000	1	4000

TABLE C-2

Equipment List - 100 Beds (cont'd)

	Improved Conven- tional		Convenience		Cook Chill (Bulk)		Ready Foods (Bulk)	
Hot Preparation Area (cont'd)								
10. Metered Cold Water Supply	1	\$ 200			1	\$ 200	1	\$ 200
11. Floor Grate Drains	Yes		Yes		Yes		Yes	
Kettle, Table Top, Tilting, W/Water Supply, Drain Trough, Sliding Dump Tray								
12. 10-Qt Kettle								
13. 20-Qt Kettle	1	1400	1	\$ 1400	1	1400	1	1400
14. 40-Qt Kettle	1	1700	1	1700	1	1700	1	1700
15. Cook's St. Steel Table (lin ft)	8	1800	8	1600	8	1800	8	1800
W/1 Sink & Disposer, W/3 Drawers & Undershelf								
18. Mobile Work Table	4	700			4	700	4	700
17. Undertable Utility Cart, St. Steel	1	200	1	200	1	200	1	200
18. Pot Rack, Wall-Mounted, 2-Tier (lin ft)	3	150	3	150	3	150	3	150
19. Pan Storage Shelf, Mobile (lin ft)	3	650	3	650	3	650	3	550
20. Cook's Refrigerator, Reach-In (Compartment)	1	1650	1	1650	1	1650	1	1650
21. Cook's Freezer, Reach-In (Compartments)	1	1850	1	1850	1	1850	1	1850
22. Hand Sink W/Wrist Blade Faucets	1	-	1	-	1	-	1	-
23. Exhaust Hood, Self Cleaning With Fire Protection (lin ft)		27750		10500		24000		24000
24. Floor Mixer (qt)	60	3350	30	1850	60	3350	60	3350
25. Slicer on Mobile Stand	1	1800	1	1800	1	1800	1	1800
26. Trash Receptacle	1	50	1	50	1	50	1	50
27. Hot Storage Cabinet, Mobile	1	700						
Subtotal		\$63750		\$28250		\$58600		\$58600
Baking & Pastry								
1. Ovens, Bake (# of Decks)	2	2550			2	2550	2	2550
2. Ovens, Convection (# of Compartments)	1	1450	1	1450	1	1450	1	1450
3. Kettle, Table Mount Tilt W/Drain Trough, Sliding Dump Tray & Water Supply (qt)	40	1750			40	1750	40	1750
4. Baker's Range, 2-Burner	1	650			1	650	1	650
5. Floor Grate for Kettles	Yes		Yes		Yes		Yes	
8. Exhaust Hood Self Cleaning W/Fire Prot. (lin ft)	4	1800			4	1800	4	1800
7. Baker's Table, 8-Ft Maple Top W/3 Drawers	-		-		-		-	

TABLE C-2

Equipment List - 100 Beds (cont'd)

	Improved Conven- tional		Convenience		Cook Chlll (Bulk)		Ready Foods (Bulk)	
Baking & Pastry (cont'd)								
8. St. Steel Work Table (lin ft) W/Sink, 1 Compartment W/Over Shelf & Recipe Rail	6	\$ 800	6	\$ 800	6	\$ 800	6	\$ 800
9. Mixer W/Stand (qt)	20	1600			20	1600	20	1600
10. Pot Rack, Mobila (lin ft)	3	100			3	100	3	100
11. Cooling Rack, Butterfly	1	200	1	200	1	200	1	200
12. Cart, Bakar Racks	1	250	1	250	1	250	1	250
13. Rafrigerator, Reach-In (Compartment)	2	2100			2	2100	2	2100
14. Utility Cart, Undercounter	1	200	1	200	1	200	1	200
15. Hand Sink W/Wrist Blade Controls				Shared				
16. Ingredient Bins	2	200			2	200	2	200
17. Trash Receptacles	1	50	1	50	1	50	1	50
Subtotal		\$13700		\$ 2900		\$13700		\$13700
Portioning & Packaging Area								
1. 10' Mobile Portioning Conveyor Shared W/Finish Prep.					-		-	
2. Mobile Portioning Table (lin ft)					6	700	6	700
3. Utility Cart					2	400	2	400
4. Mobile Cart, Cooler Backup					4	800	4	800
5. Preportioning Scale - Over/Under 10 kg (Bulk Pan)					1	400	1	400
6. Tray Convayor - Shared W/PTA								
7. Precooler - Included In Refrigeration					-		-	
8. Blast Freezer Refrigeration					-		-	
Subtotal						\$ 2300		\$ 2300
Warewashing Area -Pot & Pan								
1. Soak Sink for Pans (24"x24")	1	500			1	500	1	500
2. Pot Sink - 3-Compartment W/Drainboard	1	1200	1	1200	1	1200	1	1200
3. Scrapping Table W/Disposer & Overhead Rinse Hose (lin ft)	5	1550	4	1450	5	1550	5	1550
4. Transport Racks for Soiled Pans	3	750	2	500	3	750	3	750
5. Pot & Utensil Washer W/Hood & Booster Heater								
6. Floor Mats	Yes		Yes		Yes		Yes	

Table C-2

Equipment List - 100 Beds (cont'd)

	Improved Conven- tional		Convenience		Cook Chill (Bulk)		Ready Foods (Bulk)	
Warewashing Area - Dishware								
7. Soiled Dish Bussing Racks	4	\$ 1800	4	\$ 1800	4	\$ 1800	4	\$ 1800
8. Dishwasher, Single Tank, 44"W/Tables	1	7000	1	7000	1	7000	1	7000
9. Dishwasher, Carousel W/ Dryer (lin ft)	-	-	-	-	-	-	-	-
10. Scrapping Table W/Trough Disposer W/Overhead Rinse Hose (lin ft)	-	-	-	-	-	-	-	-
11. Dish Truck	5	3000	5	3000	5	3000	5	3000
12. Rack Dolly, Dishes & Mugs	2	700	4	1400	4	1400	4	1400
13. Tray Dolly, Single Stack	1	150	2	300	2	300	2	300
14. Soak Slnk, Utensils	1	500	1	500	1	500	1	500
15. Utensil Sorting Table (lin ft)	5	550	5	550	5	550	5	550
18. Carts for Soiled Pot Trays	See Tray Assembly							
17. Reck Dolly or Dish Truck	-	-	-	-	-	-	-	-
18. Trash Receptacles	1	50	1	50	1	50	1	50
19. Compactor	-	-	-	-	-	-	-	-
20. Manual Cartwash W/Detergent Injector	1	650	1	650	1	850	1	850
21. Automatic Cartwash	-	-	-	-	-	-	-	-
Subtotal		\$18200		\$18200		\$19050		\$ 19050
Patient Tray Assembly Area								
1. Tray Dispenser (# of Stacks)	1	400	1	400	1	400	1	400
2. Starter Unit	1	1000	1	1000	1	1000	1	1000
3. Tray Conveyor (# of Positions)	4	4800	2	2000	2	2000	2	2000
4. Plate Dispenser (# of Tubes)	-	-	2	750	2	750	2	750
5. Plate Dispenser, Heated (# of Tubes)	2	750	-	-	-	-	-	-
8. Veg. Dish Dispenser (# of Tubes)	-	-	2	500	2	500	2	500
7. Dish Dispenser Heated (# of Tubes)	2	650	-	-	-	-	-	-
8. Bowl Dispenser (# of Tubes)	2	650	-	-	-	-	-	-
9. Mug Dispenser (Rack Lowerator)	1	650	1	550	1	650	1	650
10. Glass Dispenser	1	450	1	450	1	450	1	450
11. Preportioned Cold Food Rack (Soup-Cold Plates)	3	800	3	600	3	600	3	600
12. Cold Food Table (Portioning Wells)	-	-	8	2800	8	2800	8	2800
13. Hot Food Table (Portioning Wells)	8	3200	-	-	-	-	-	-
14. Bread & Ambient Station (rewrapped)	1	850	1	650	1	650	1	650
15. Toaster	1	200	-	-	-	-	-	-
18. Milk Dispenser (Cooled Lowerator)	1	1000	1	1000	1	1000	1	1000
17. Cold Beverage Station W/Tea, Canned Soda, Juices, etc.	1	900	1	900	1	900	1	900
18. Hot Beverage Station W/Coffee Urn	1	1800	1	1800	1	1800	1	1800

TABLE C-2

Equipment List - 100 Beds (cont'd)

	Improved Conven- tional		Convenience		Cook Chill (Bulk)		Ready Foods (Bulk)	
Patient Tray Assembly Area (cont'd)								
19. Ice Maker/Dispenser	1	\$ 4000	-		-		-	
20. Ice Cream Dispenser (Frozen Lowerator)	1	1050	-		-		-	
Subtotal		\$22750		\$13500		\$13500		\$13500
Dining Hall Area								
1. Cashier - Headcount Position (Chair, Table, & Cash System)	1	-	1	-	1	-	1	-
2. Tray & Silver Stand, Lowerator (# Stacks)	2	700	2	700	2	700	2	700
3. Hot Food Counter/Tray Rail, Sneeze Guard (# of Wells)	7	2350	7	2350	7	2350	7	2370
4. Convection Oven (# of Compartments)			1	1400	1	1400	1	1400
5. Roll-In, Pass Thru-Hot Food Warmer (Single Cart)	1	3500						
6. Plate Lowerator, Heated (# of Tubes)	4	1500	4	1500	4	1500	4	1500
7. Bowl Lowerator, Heated (# of Tubes)	4	1500	4	1500	4	1500	4	1500
B. Vegetable Dish Lowerator, Heated	1	450	1	450	1	450	1	450
9. Short Order Counter W/Tray Rack & Sneeze Guard (# of Hot Wells)	2	2400	2	2400	2	2400	2	2400
10. Sandwich Section W/Tray Rail, Sneeze Guard & Cold Wells, Made to Order (lin ft)	4	2900	4	2900	4	2900	4	2900
11. Pass Thru Refrigerator - Holder	-		1	2800	1	2800	1	2800
12. Grill Flat Top (lin ft)	4	1800	4	1800	4	1800	4	1800
13. Fryer W/Spreader (# of Wells)	1	1200	1	1200	1	1200	1	1200
14. Exhaust Hood (lin ft)	6	4500	6	4500	6	4500	6	4500
15. Counter Top Steamer (Single Compartment)			1	1300	1	1300	1	1300
16. Undercounter Refrigerator	1	1250	1	1250	1	1250	1	1250
17. Undercounter Freezer	1	1250	1	1250	1	1250	1	1250
18. Workcounter W/Sink (lin ft)	4	1000	4	1000	4	1000	4	1000
19. Handwash Sink	1	250	1	250	1	250	1	250
20. Toaster (# of Slices)	4	300	4	300	4	300	4	300
21. Beverage Island W/Dispensers for Milk & Carborated Beverages (4), Cold Beverages (2), Iced Tea, Hot Coffee, Hot Water, Cream, & Hot Chocolate	1	14500	1	14500	1	14500	1	14500
22. Mug & Gless Lowerator (or disposables dispenser)	2	1100	2	1100	2	1100	2	1100
23. Condiment Island W/Bread Disp. Butter disp., Portion Control, Condiments & Dressings, Chilled Water Disp, Glass Lowerator, end Fruit, etc.	1	8100	1	8100	1	8100	1	8100

TABLE C-2

Equipment List - 100 Beds (cont'd)

	Improved Conven- tional	Convenience	Cook Chill (Bulk)	Ready Foods (Bulk)
Dining Hall Area (cont'd)				
24. Salad & Dessert Island - Chilled Bottom Shelf W/2 Above Shelves, & Undercounter Storage	1 \$ 4450	1 \$ 4450	1 \$ 4450	1 \$ 4450
25. Soft Ice Cream Dispenser	1 6000	1 6000	1 6000	1 6000
26. Dish Lowerator for Soft Serve	1 550	1 550	1 550	1 550
27. Cold Pass Thru Refrigerator - Salads & Desserts	1 2800	1 2800	1 2800	1 2800
Subtotal	\$64350	\$66350	\$66350	\$66350
40-Bed Galley Area				
1. Nourishment Station W/6' Work Counter, 2' Overhead Cabinet Undercounter Storage Hot Water Dispenser Undercounter Refrigerator Undercounter Freezer Work Sink Ice Maker/Dispenser Trash Receptacle	3 18000	3 18000	3 18000	3 18000
2. Rethermalization Transport Module		10 50000	10 50000	10 50000
Subtotal	\$18000	\$68000	\$68000	\$68000

TABLE C-3

Area Equipment Costs – 250 Beds

	Improved Conventional	Convenience	Cook-Chill (Bulk)	Ready Foods (Bulk)
Receiving & Shipping	\$ 4,900	\$ 5,050	\$ 4,900	\$ 4,900
Trash	450	450	450	450
Bulk Stores	3,350	3,040	3,350	3,350
Day Stores & Non Food Stores	2,100	1,960	2,100	2,100
Issue & Ingredient Area	12,700	—	12,850	12,850
Rough Preparation	11,340	6,595	11,340	11,340
Refrigeration	36,300	71,250	76,900	126,300
Cold Preparation Area	17,900	17,000	17,900	17,900
Special Diet/Nourishment Station	7,290	7,290	7,290	7,290
Hot Preparation Area	87,500	37,300	77,650	80,900
Baking & Pastry	32,900	4,650	32,900	32,900
Meat Shop	7,750	—	7,750	7,750
Warewashing	48,000	47,800	49,000	49,000
Portioning & Packaging	—	—	3,200	3,200
Patient Tray Assembly	33,650	19,450	19,450	19,450
Dining Hall	70,850	74,200	74,200	74,200
40 Bed Galley Area	42,000	172,000	172,000	172,000
GRAND TOTAL	\$418,980	\$468,035	\$573,230	\$625,880

TABLE C-4

Equipment List - 250 Beds

	Improved Conven- tional		Convenience		Cook-Chill (Bulk)		Ready Foods (Bulk)	
Receiving & Shipping Area								
1. Printing Floor Scale	1	\$ 2300	1	\$ 2300	1	\$ 2300	1	\$ 2300
2. Dock Leveler	1	-	1	-	1	-	1	-
3. Table, Inspection (3'x5'x30")	1	600	1	600	1	600	1	600
4. Platform Hand Truck (30"x48")	2	800	2	800	2	800	2	800
5. Pallet Truck	1	600	1	600	1	600	1	600
6. Pallets	5	150	10	300	5	150	5	150
7. Desk & Chair	1	-	1	-	1	-	1	-
8. Hand Sink	1	250	1	250	1	250	1	250
9. Hand Cart	2	200	2	200	2	200	2	200
Subtotal		\$ 4900		\$ 5050		\$ 4900		\$ 4900
Trash Area								
1. Can Crusher	-	-	-	-	-	-	-	-
2. Compactor or Bulk Haul-off Cont.	Shared with Hospital Waste Holding							
3. Staging Refrigerator	-	-	-	-	-	-	-	-
4. Can Washer	1	450	1	450	1	450	1	450
Subtotal		\$ 450		\$ 450		\$ 450		\$ 450
Bulk Stores Area (15 Days @ Ambient)								
1. Shelving (24"x48"x60") (lin ft)	20	2800	18	2520	20	2800	20	2800
2. Pallets (Dunnage)	5	150	4	120	5	150	5	150
3. Pallet Truck	1	400	1	400	1	400	1	400
4. Battery Charger	-	-	-	-	-	-	-	-
5. Walkie Forklift	-	-	-	-	-	-	-	-
5. Desk & Chair	1	-	1	-	1	-	1	-
Subtotal		\$ 3350		\$ 3040		\$ 3350		\$ 3350
Day Stores & Non Food Stores Area								
1. Non Food Shelving	5	700	5	700	5	700	5	700
2. Day Stores Shelving	10	1400	9	1250	10	1400	10	1400
Subtotal		\$ 2100		\$ 1950		\$ 2100		\$ 2100
Issue & Ingredient Area								
1. St. Steel Counter	B	1000			B	1000	B	1000
W/12" Backsplash (lin ft)								
W/Self Draining Edge								
W/18" Sink								
W/Undershelf Bins								
W/Drawer	2	200			2	200	2	200

TABLE C-4

Equipment List -- 250 Beds

	Improved Conven- tional		Convenience		Cook-Chill (Bulk)		Ready Foods (Bulk)
Issue & Ingredient Area (cont'd)							
2. Overshelf (12") -- (lin ft)	8	\$ 150			6	\$ 150	6 \$ 150
3. Mobile Bins W/Covers	5	700			6	850	6 850
4. Batch Carts -- Bakery Rack (18"x26"x60")	8	1800			8	1800	8 1800
5. Shelving (Spices, Sm. Food Items) 18" Mobile	4	260			4	250	4 250
6. Bag Dispenser	1	250			1	260	1 250
7. Portable Electric Can Opener	1	400			1	400	1 400
8. Bench Scale, Table Top, Digital Readout, Metric & Avoirdupois to 12 kg	—				—		—
9. Bench Scale to 226 kg	1	500			1	500	1 500
10. Spica Scale (Portion Scale) Metric & Avoirdupois to 1 kg	1	300			1	300	1 300
11. Refrigerator, Reach-in (No. of Compartments)	4	4000			4	4000	4 4000
12. Freezer, Reach-in (No. of Compartments)	2	2250			2	2250	2 2250
13. Trash Receptacle	1	50			1	50	1 50
14. Utility Cart	1	200			1	200	1 200
15. Platform Truck (Bulk Stores, Trash)	1	400			1	400	1 400
16. Can Crusher	—				—		—
17. Compactor	—				—		—
18. Hand Sink W/Wrist Blade Faucets & Towel & Soap Dispenser	1	250			1	250	1 250
Subtotal		\$12700				\$ 12850	\$ 12850
Rough Prep. (Vegetable Prep.) Area							
1. St. Steel Work Counter W/12" Backsplash (lin ft) W/3-Compartment Sink W/Right Hand Drainboard W/Waste Disposal	12	3250	12	\$ 3250	12	3250	12 3250
2. Root Veg Peeler on Fixed Stand	1	1100			1	1100	1 1100
3. Cabbage Corer, Portable	—				—		—
4. Bench Platform Scale to 12 kg, Metric & Avoirdupois	1	500	1	500	1	500	1 500

TABLE C-4

Equipment List - 250 Beds

	Improved Conventional		Convenience		Cook-Chill (Bulk)		Ready Foods (Bulk)	
Rough Prep. (Vegetable Prep.) Area								
5. Food Cutter, Counter Top	1	\$ 1700	1	\$ 1700	1	\$ 1700	1	\$ 1700
6. Storage Cabinet (lin ft)	3	450	3	450	3	450	3	450
7. Cart (Bakery Reck)	4	900	2	225	4	900	4	900
B. Ingredient Tubs, Stack & Nest (2ft ³)	12	240	6	120	12	240	12	240
9. Platform Truck for Inged. Tubs	1	400			1	400	1	400
10. Mobile Shelving for Container Storage, 24"x72"h (lin ft)	3	350	3	350	3	350	3	350
11. Work Counter W/12" Becksplash (lin ft) W/Sinks - 2 Compartments et end W/Disposer in Sink	7	1100			7	1100	7	1100
			Yes					
		1350				1350		1350
Subtotal		\$11340		\$ 6595		\$ 11340		\$ 11340
Refrigerator Area								
1. Normal Welk-in Refrigerator (35°F) W/St. Steel Mobile Shelves, Dunnage Racks & Certs - (sq ft)	260	16500	210	13750	260	16500	260	16500
2. Low Temperature Walk-in Refrigerator (-10°F) W/St. Steel Mobile Shelving, Dunnage Racks, & Certs (ft ²)	240	17700	120	7500	240	17700	240	17700
3. Holding Refrigerator (35°F, 3 days) Storage Containers					100	6900		4100
4. Holding Refrigerator (-10°F, 15 deys) Storage Containers			450	31300	140	10800	625	44100
								20700
5. Blast Freezer - Roll-in (-50°F) Carts					1	2260		
					1	250		
6. Blast Freezer Welk-in (-50°F) Certs							4	4000
							4	1000
7. Pre Cooler Refrigerator (35°F) Walk-in					4	3600	4	3600
8. Tempering Refrigerator (38°F) Roll-in (Compartments) Certs					2	2650		
					2	500		
9. Tempering Refrigerator (38°F) Walk-in			7	5300			7	5300
			7	1750			7	1750

TABLE C-4

Equipment List - 250 Beds

	Improved Conven- tional		Convenience		Cook-Chill (Bulk)		Ready Foods (Bulk)	
Refrigerator Area (cont'd)								
10. Patient Staging Refrigerator (35°F)								
Roll-in Compartments	1	\$ 1850	2	\$ 2650	2	\$ 2650	2	\$ 2650
Carts	1	250	2	500	2	500	2	500
11. Patient Tray Delivery Cart Holding Refrigerator (36°F) (ft ²)			130	8500	130	8500	130	8500
Subtotal		\$36300		\$ 71250		\$ 76900		\$126300
Cold Preparation Area - Preportioning Salads, Cold Plates, Sandwich Assembly								
1. Steel Counter W/12" Backsplash (lin ft) W/2 Compartment Sink W/Disposer (1 H.P.) W/Over & Under Shelf	13	2550	12	2450	13	2550	13	2550
2. Mobile Work Table (3 to 4 ft)	6	2400	4	1600	6	2400	6	2400
3. Portioning Conveyor	-		-		-		-	
4. Mobile Supply Cart W/Worktop	6	1200	6	1200	6	1200	6	1200
5. Slicer W/Stand	1	1800	1	1800	1	1800	1	1800
6. Mixer W/Stand (20-qt)	1	1550	1	1550	1	1550	1	1550
7. Refrigerator, Reach-in (Compartment)	4	4200	4	4200	4	4200	4	4200
8. Refrigerator, Walk-in (Included in Normal Temp Allocation)								
9. Freezer, Reach-in (Compartments)	2	2250	2	2250	2	2250	2	2250
10. Cart (Bakery Rack)	4	800	4	800	4	800	4	800
11. Container Storage Mobile Shelves (lin ft)	6	700	6	700	6	700	6	700
12. Dish Racks or Dollies	3	400	3	400	3	400	3	400
13. Trash Receptacles	1	50	1	50	1	50	1	50
Subtotal		\$17900		\$ 17000		\$ 17900		\$ 17900
Special Diets/Nourishment Station								
1. Work Counter W/12" Backsplash (lin ft) W/One Compartment Sink W/3 Drawers W/Undercounter Shelf	10	1600	10	1600	10	1600	10	1600
2. Overhead 12" shelf W/Recipe Rail (lin ft)	6	160	6	150	6	150	6	150
3. Blender	1	300	1	300	1	300	1	300
4. Refrigerator, Roll-in (Cart Capacity)	1	1860	1	1850	1	1850	1	1850

TABLE C-4

Equipment List - 250 Beds

	Improved Conven- tional		Convenience		Cook-Chill (Bulk)		Ready Foods (Bulk)	
Special Diets/Nourishment Station (cont'd)								
5. Refrigerator, Reach-in (Compartments)	2	\$ 2100	2	\$ 2100	2	\$ 2100	2	\$ 2100
6. Portion Scale	1	300	1	300	1	300	1	300
7. Microwave Oven	-		-		-		-	
8. Storage Cabinet (linear ft)	3	600	3	600	3	600	3	600
9. Film Dispenser, Wall Mounted	1	20	1	20	1	20	1	20
10. Disposable Cup Dispenser, Wall Mount	3	90	3	90	3	90	3	90
11. Label Dispenser, Wall Mount	1	30	1	30	1	30	1	30
12. Utility Cart, Undercounter	1	200	1	200	1	200	1	200
13. Trash Receptacle	1	50	1	50	1	50	1	50
14. Hand Sink W/Wrist Blade Faucets				Shared				
Subtotal		\$ 7290		\$ 7290		\$ 7290		\$ 7290
Hot Preparation Area								
1. Range, Conventional (Heating Positions)	4	1200			4	1200	4	1200
2. Range, Hot Top (linear ft)	4	1900						
3. Range, Griddle Top (linear ft)	3	1350			3	1350	3	1350
4. Broiler-Grill Comb. (linear ft)	4	2100			4	2100	4	2100
5. Oven, Convection (Compartments)	4	5500	2	2750	4	5500	2	2750
6. Oven, Convection, Roll-in							1	6000
7. Fryer W/Spreader, Fat Filter	1	2100			1	2100	1	2100
8. Broiler	-				-		-	
9. Breising Pen	1	2150	1	2150	1	2150	1	2150
10. Steamer, Convection (Compartments)	1	2600						
11. Steamer, Pressure (Compartments)	1	1300	1	1300	1	1300	1	1300
Kettles, Wall Mounted, Ball Valve Drain								
12. 80-Gal. Tilt					1	5000	1	5000
13. 60-Gal. Tilt	1	4600			1	4600	1	4600
14. 40-Gal. Tilt	1	4000						
15. Mixer for Kettle, Swing Away	1	6000			1	6000	1	6000
16. Metered Cold Water Supply	1	200			1	200	1	200

TABLE C-4

Equipment List - 250 Beds

	Improved Conven- tional		Convenience		Cook-Chill (Bulk)		Ready Foods (Bulk)	
Hot Preparation Area (cont'd)								
17. Circulated Cold Water System For Kettle Cooling	-				-		-	
18. Floor Grete Dreins Kettle, Table Top, Tilting, W/Water Supply, Drain Trough, Sliding Dumptray	Yes		Yes		Yes		Yes	
19. 10-Qt Kettle	1	\$ 1400						
20. 20-Qt Kettle	1	1400	1	\$ 1400	1	\$ 1400	1	\$ 1400
21. 40-Qt Kettle			2	3400	1	1700	1	1700
22. Cook's St. Steel Table (lin ft) W/1 Sink & Disposer W/3 Drawers & Undershelf	10 Yes Yes	2000	B	1800	10 Yes Yes	2000	10 Yes Yes	2000
23. Mobile Work Table	4	700			4	700	4	700
24. Undertable Utility Cart, St. Steel	2	400	1	200	2	400	2	400
25. Pot Rack, Wall Mounted 2 Tier (lin ft)	4	200	3	150	4	200	4	200
25. Pan Storage Shelf, Mobil (lin ft)	4	700	3	650	4	700	4	700
27. Cook's Refrigerator, Reach-in (Compartments)	2	2200	2	2200	2	2200	2	2200
28. Cook's Freezer, Reach-in (Compartments)	2	2550	2	2550	2	2550	2	2550
29. Hand Sink W/Wrist Blade Faucets	Yes		Yes		Yes		Yes	
30. Exhaust Hood, Selfcleaning with Fire Prot. (lin ft)		33750		13500		28500		28500
31. Floor Mixer (qt)	60	3900	60	3350	60	3900	60	3900
32. Slicer on Mobile Stand	1	1800	1	1800	1	1800	1	1800
33. Trash Receptacle	2	100	2	100	2	100	2	100
34. Hot Storage Cabinet, Mobile	2	1400						
Subtotal		\$87500		\$ 37300		\$ 77650		\$ 80900
Baking & Pastry Area								
1. Ovens, Convection (No. of Compartments)	-		2	2750	-		-	
2. Ovens, Beke, Rotary - 15-Pan	1	8800			1	8800	1	8800
3. Mixer Kettle W/Ball Drain Valve, 30-Gel Tilt	1	6000			1	6000	1	6000

TABLE C-4

Equipment List - 250 Beds

	Improved Conven- tional		Convenience		Cook-Chill (Bulk)		Ready Foods (Bulk)
Baking & Pastry Area (cont'd)							
4. Kettle, Table Mount Tilt W/Drain Trough, Sliding Dumptray & Water Supply (qt)	10	\$ 1450			10	\$ 1450	10 \$ 1450
5. Bakers Range, 2-Burner	1	650			1	650	1 650
8. Fryer W/Donut Attach., Spreader & Fat Filter	1	2700			1	2700	1 2700
7. Floor Grate for Kettles	Yes				Yes		Yes
8. Exhaust Hood Selfcleaning W/Fire Prot. (lin ft)	5	3700			5	3700	5 3700
9. St. Steel Wrk Table (lin ft) W/Sink 1 Compartment	8	950	8	\$ 950	8	950	8 950
10. Overshelf W/ Recipe Rail (lin ft)	6	50			6	50	8 50
11. Mixer, Floor-Mounted (qt)	60	3350			60	3350	60 3350
12. Mixer W/Stand (qt)	5	1100			5	1100	5 1100
13. Pot Rack, Mobile (lin ft)	4	150			4	150	4 150
14. Cooling Rack, Butterfly	1	200	1	200	1	200	1 200
15. Cart, Baker Racks	2	500	2	500	2	500	2 500
16. Refrigerator, Reach-in (Compartments)	2	2100			2	2100	2 2100
17. Utility Cart, Undercounter	1	200	1	200	1	200	1 200
18. Ingredient Bins	2	200			2	200	2 200
19. Bakers Scale	1	750			1	750	1 750
20. Trash Receptacles	1	50	1	50	1	50	1 50
Subtotal		\$32900		\$ 4650		\$ 32900	\$ 32900
Meat Shop							
1. Trim & Trash Receptacles	2	100			2	100	2 100
2. St. Steel Table W/2-Compartment Sink (lin ft) W/Built-in Grinder, Undertable	8	1100			8	1100	8 1100
3. Platform Floor Scale, Mobile	1	1500			1	1500	1 1500
4. Portable Meat Cutting Table (lin ft) W/Resilient Wood Top	1	1600			1	1600	1 1600
4. Portable Meat Cutting Table (lin ft) W/Resilient Wood Top	4	600			4	600	4 600
5. Patty Former	1	1700			1	1700	1 1700
8. Utility Cart	1	200			1	200	1 200
7. Platform Hand Cart	1	150			1	150	1 150
8. Hose Station W/Detergent Injector	1	200			1	200	1 200
9. Knife Rack, Magnetic	1	100			1	100	1 100
10. Hand Sink W/Wrist Blade Controls	1	350			1	350	1 350
11. Butcher Paper Dispenser, Wall	1	50			1	50	1 50
12. Meat Lugs	4	100			4	100	4 100
13. Walk-in Refrigerator, Walk-in Freezer (Included W/Allocation)							
Subtotal		\$ 7750				\$ 7750	\$ 7750

TABLE C-4

Equipment List - 250 Beds

	Improved Conven- tional		Convenience		Cook-Chill (Bulk)		Ready Foods (Bulk)
Portioning & Packaging Area							
1. 10' Mobile Portioning Conveyor Shared W/Finish Prep.					-		-
2. Mobile Portioning Table (lin ft)					10	\$ 1200	10 \$ 1200
3. Utility Cart					2	400	2 400
4. Mobile Cart, Cooler Backup					6	1200	6 1200
5. Preportioning Scale - Over/Under 10 kg (Bulk Pan)					1	400	1 400
6. Tray Conveyor Shered W/PTA							
7. Precooler (Included in Refrig. Allotment)							
8. Blast Freezer (Included in Refrig. Allotment)							
Subtotal						\$ 3200	\$ 3200
Warewashing Area - Pot & Pan							
1. Soak Sink for Pans (24"x24")	1	\$ 500			1	500	1 500
2. Pot Sink - 3-Compartment W/Drainboard	1	1200	1	\$ 1200	1	1200	1 1200
3. Scrapping Table W/Disposer & Overhead Rinse Hose (lin ft)	6	1650	4	1450	6	1650	6 1650
4. Transport Racks for Soiled Pans	4	1000	2	500	4	1000	4 1000
5. Floor Mats	Yes		Yes		Yes		Yes
Warewashing Area - Dishware							
6. Soiled Dish Bussing Racks	6	2400	6	2400	6	2400	6 2400
7. Dishwasher, Carousel W/Dryer (lin ft)	22	29000	22	29000	22	29000	22 29000
8. Scrapping Table W/Trough, Disposer & Overhead Rinse Hose (lin ft)	14	2750	14	2750	14	2750	14 2750
9. Dish Truck	10	6000	10	6000	10	6000	10 6000
10. Rack Dolly, Dishes & Mugs	4	1400	6	2100	6	2100	6 2100
11. Tray Dolly, Single Stack	2	300	4	600	4	600	4 600
12. Soak Sink, Utensils	1	500	1	500	1	500	1 500
13. Utensil Sorting Table (lin ft)	5	550	5	550	5	550	5 550
14. Carts for Soiled Pot Trays							
							Shared with PTA

TABLE C-4

Equipment List -- 250 Beds

	Improved Conven- tional	Convenience	Cook-Chill (Bulk)	Ready Foods (Bulk)
Warewashing Area -- Dishware (cont'd)				
15. Rack Dolly or Dish Truck	-	-	-	-
16. Trash Receptacles	2 \$ 100	2 \$ 100	2 \$ 100	2 \$ 100
17. Compactor	-	-	-	-
18. Manual Cartwash W/Detergent Injector	1 650	1 650	1 650	1 650
19. Automatic Cartwash	-	-	-	-
Subtotal	\$48000	\$ 47800	\$ 49000	\$ 49000
Patient Tray Assembly Area				
1. Tray Dispenser (No. of Stecks)	2 600	2 600	2 600	2 600
2. Starter Unit	1 1000	1 1000	1 1000	1 1000
3. Tray Conveyor (No. of Positions)	7 8000	4 4000	4 4000	4 4000
4. Plate Dispenser (No. of Tubes)	-	4 1150	4 1150	4 1150
5. Plate Dispenser, Haated (No. of Tubes)	4 1500	-	-	-
5. Veg. Dish Dispenser (No. of Tubes)	-	4 900	4 900	4 900
7. Dish Dispenser, Heated (No. of Tubes)	4 1300	-	-	-
8. Bowl Dispenser (No. of Tubes)	4 1300	-	-	-
9. Mug Dispenser (Rack Lowerator)	2 1300	2 1300	2 1300	2 1300
10. Glass Dispenser	2 900	2 900	2 900	2 900
11. Preportioned Cold Food Rack (Soup - Cold Plate)	4 800	5 1000	5 1000	5 1000
12. Cold Food Table (Portioning Wells)	-	8 2800	8 2800	8 2800
13. Hot Food Table (Portioning Wells)	8 3200	-	-	-
14. Bread & Ambient Station (Prewrapped)	1 650	1 650	1 650	1 650
15. Toaster	1 400	-	-	-
18. Milk Dispenser (Cooled Lowerator)	2 2000	2 2000	2 2000	2 2000
17. Cold Beverage Station W/Tee, Canned Soda, Juices, etc.	1 1350	1 1350	1 1350	1 1350
18. Hot Beverage Station W/Coffee Urn	1 1800	1 1800	1 1800	1 1800

TABLE C-4

Equipment List - 250 Beds

	Improved Conven- tional		Convenience		Cook-Chill (Bulk)		Ready Foods (Bulk)	
Patient Tray Assembly Area (cont'd)								
19. Ice Maker/Dispenser	1	\$ 5500	-	-	-	-	-	-
20. Ice Cream Dispenser (Frozen Lowerator)	1	1050	-	-	-	-	-	-
Subtotal		\$33550		\$ 19450		\$ 19450		\$ 19450
Dining Hall Area								
1. Cashier - Head Count Position (At Entrance)	1	-	1	-	1	-	1	-
2. Tray & Silver Stand, Lowerator (No. Stacks) Hot Food Counter/Tray Rail	3	1200	3	1200	3	1200	3	1200
3. Sneeze Guard (No. of Wells)	7	2350	7	2350	7	2350	7	2350
4. Convection Ovan (No. of Compartments)			2	2750	2	2750	2	2750
5. Roll-in, Pass Thru - Hot Food Warmer (Single Cart)	1	3500						
6. Plate Lowerator, Heated (No. of Tubes)	5	2000	5	2000	5	2000	5	2000
7. Bowl Lowerator, Heated (No. of Tubes)	5	2000	5	2000	5	2000	5	2000
8. Vegetable Dish Lowerator, Heated	3	1350	3	1350	3	1350	3	1350
9. Short Order Counter W/Tray Rail & Sneeze Guard (No. of Hot Wells)	3	2800	3	2800	3	2800	3	2800
10. Sandwich Section W/Tray Rail, Sneeze Guard & Cold Wells, Made to Order (lin ft)	5	3700	6	3700	5	3700	6	3700
11. Pass Thru Refrigerator-Holder	-		1	2800	1	2800	1	2800
12. Grill Flattop (lin ft)	4	1800	4	1800	4	1800	4	1800
13. Fryer W/Spreader (No. of Wells)	2	2400	2	2400	2	2400	2	2400
14. Exhaust Hood (lin ft)	7	5250	7	5250	7	5250	7	5250
15. Counter Top Steamar (Single Compart)			1	1300	1	1300	1	1300
16. Undercounter Refrigerator	1	1250	1	1250	1	1250	1	1250
17. Undercounter Freezer	1	1250	1	1250	1	1250	1	1250
18. Workcounter W/Sink (lin ft)	5	1250	5	1250	5	1250	5	1250
19. Handwash Sink	1	250	1	250	1	250	1	250
20. Toaster (No. of Slices)	5	450	5	450	6	450	6	450
21. Beverage Island W/Dispensers for Milk, Carbonated Beverages (4), Cold Beverages (2), Iced Tea, Hot Coffee, Hot Water, Cream & Hot Chocolate	1	14500	1	14500	1	14500	1	14500

TABLE C-4

Equipment List - 250 Beds

	Improved Conven- tional		Convenience		Cook-Chill (Bulk)		Ready Foods (Bulk)
Dining Hall Area (cont'd)							
22. Mug & Glass Lowerator (or Disposable Dispenser)	3	\$ 1650	3	\$ 1650	3	\$ 1650	3 \$ 1650
23. Condiment Island W/Bread Disp., Butter Disp., Portion Control Condiments & Dressing, Chilled Water Disp., Glass Lowerator, and Fruit, Etc.	1	8100	1	8100	1	8100	1 8100
24. Salad & Dessert Island - Chilled Bottom Shelf W/2 Above Shelves, Undercounter Storage	1	4450	1	4450	1	4450	1 4450
25. Soft Ice Cream Dispenser	1	6000	1	6000	1	6000	1 6000
26. Dish Lowerator for Soft Serve	1	550	1	550	1	550	1 550
27. Cold Pass Thru Refrigerator - Salads & Desserts	1	2800	1	2800	1	2800	1 2800
Subtotal		\$70850		\$ 74200		\$ 74200	\$ 74200
40-Bed Galley Area							
1. Nourishment Station W/6' Work Counter W/2' Overhead Cabinet W/Undercounter Storage W/Hot Water Dispenser W/Undercounter Refrigerator W/Undercounter Freezer W/Work Sink Ice Maker/Dispenser Trash Receptacle	7	42000	7	42000	7	42000	7 42000
2. Rethermalization Transport Module			26	130000	26	130000	26 130000
Subtotal		\$42000		\$172000		\$172000	\$172000

TABLE C-5

Area Equipment Costs, 550 Beds

	Improved Conventional	Convenience	Cook-Chill (Bulk)	Ready Foods (Bulk)
Receiving & Shipping	\$ 5,450	\$ 5,350	\$ 5,450	\$ 5,450
Trash	450	450	450	450
Bulk Stores	9,090	8300	9,090	9,090
Day Stores & Non Food Stores	4,200	3,780	4,200	4,200
Issue & Ingredient Area	18,750	—	18,850	19,000
Rough Preparation	13,220	7,385	13,220	13,220
Refrigeration	66,150	133,530	133,920	228,430
Cold Preparation Area	22,800	21,100	22,800	22,800
Special Diet/Nourishment Station	8,690	8,690	8,690	8,690
Hot Preparation Area	113,000	44,850	104,150	104,650
Baking & Pastry	50,750	6,300	50,750	50,750
Meat Shop	8,800	—	8,800	8,800
Warewashing	68,400	64,450	70,950	70,950
Portioning & Packaging	—	—	4,500	4,500
Patient Tray Assembly	54,300	30,950	30,950	30,950
Dining Hall	84,550	87,450	87,450	87,450
40 Bed Galley Area	84,000	364,000	364,000	364,000
GRAND TOTAL	\$612,600	\$779,115	\$938,220	\$1,033,380

TABLE C-6

Equipment List - 550 Beds

	Improved Conven- tional		Convenience		Cook Chill (Bulk)		Ready Foods (Bulk)	
Receiving & Shipping Area								
1. Printing Floor Scale	1	\$ 2300	1	\$ 2300	1	\$ 2300	1	\$ 2300
2. Dock Leveler	1	-	1	-	1	-	1	-
3. Table, Inspection (3'x6'x30")	1	600	1	600	1	600	1	600
4. Platform Hand Truck (30"x48")	3	1200	2	800	3	1200	3	1200
5. Pallet Truck	1	600	1	600	1	600	1	600
6. Pallets	10	300	20	600	10	300	10	300
7. Desk & Chair	1	-	1	-	1	-	1	-
8. Hand Sink	1	250	1	250	1	250	1	250
9. Hand Cart	2	200	2	200	2	200	2	200
Subtotal		\$ 5450		\$ 5360		\$ 5450		\$ 5450
Trash Area								
1. Can Crusher	-	-	-	-	-	-	-	-
2. Compactor or Bulk Haul-Off Cont.	Shared W/Hospital Waste Handling							
3. Staging Refrigerator	-	-	-	-	-	-	-	-
4. Can Washer	1	450	1	450	1	450	1	450
Subtotal		\$ 450		\$ 450		\$ 450		\$ 450
Bulk Stores Area (15 Days @ Ambient)								
1. Shelving (24"x48"x60") (lin ft)	35	4900	30	4200	35	4900	35	4900
2. Pallets (Dunnage)	13	390	10	300	13	390	13	390
3. Pallet Truck	2	800	2	800	2	800	2	800
4. Battery Charger	1	500	1	500	1	500	1	500
5. Walkie Forklift	1	2500	1	2500	1	2500	1	2500
6. Desk & Chair	1	-	1	-	1	-	1	-
Subtotal		\$ 9090		\$ 8300		\$ 9090		\$ 9090
Day Stores (4 days) & Non Food Stores Area								
1. Non Food Shelving	10	1400	10	1400	10	1400	10	1400
2. Day Stores Shelving	20	2800	17	2380	20	2800	20	2800
Subtotal		\$ 4200		\$ 3780		\$ 4200		\$ 4200

TABLE C-8

Equipment List - 550 Beds (cont'd)

	Improved Conven- tional		Convenience		Cook Chill (Bulk)		Ready Foods (Bulk)	
Issue & Ingredient Area								
1. St. Steel Counter W/12" Backsplash (lin ft) W/Shelf Draining Edge W/18" Sink W/Right Hand Drainboard W/Undershelf Bins W/Drawer	10	\$ 1200			10	\$ 1200	10	\$ 1200
2. Overshelf (12") (lin ft)	8	200			8	200	8	200
3. Mobile Bins W/Covers	9	1300			10	1400	11	1550
4. Batch Carts - Bakery Rack (18"x26"x60")	12	2700			12	2700	12	2700
5. Shelving (Spices, Sm. Food Items) 18" Mobile	5	300			5	300	5	300
6. Bag Dispenser	1	250			1	250	1	250
7. Portable Electric Can Opener	1	400			1	400	1	400
8. Bench Scale, Table Top, Digital Readout, Metric & Avoirdupois to 12 kg	-				-		-	
9. Bench Scale to 22.5 kg	1	500			1	500	1	500
10. Spice Scale (Portion Scale) - Metric & Avoirdupois to 1 kg	1	300			1	300	1	300
11. Refrigerator, Reach-In (No. of Compartments)	6	6000			6	6000	6	6000
12. Freezer, Reach-In (No. of Compartments)	4	4500			4	4500	4	4500
13. Trash Receptacle	1	50			1	50	1	50
14. Utility Cart	1	200			1	200	1	200
15. Platform Truck (Bulk Stores, Trash)	1	400			1	400	1	400
16. Can Crusher	-				-		-	
17. Compactor	-				-		-	
18. Hand Sink W/Wrist Blade Faucets & Towel & Soap Dispenser	1	250			1	250	1	250
Subtotal		\$18750				\$18850		\$19000
Rough Prep. (Vegetable Prep.) Area								
1. St. Steel Work Counter W/12" Backsplash (lin ft) W/3 Compartment Sink W/Right Hand Drainboard W/Waste Disposal	13	2000	13	2000	13	2000	13	2000
	1	1350	1	1350	1	1350	1	1350

TABLE C-6

Equipment List - 550 Beds (cont'd)

	Improved Conven- tional		Convenience		Cook Chill (Bulk)		Ready Foods (Bulk)	
Rough Prep. (Vegetable Prep.) Area								
2. Root Veg. Peeler on Fixed Stand	1	\$ 1100			1	\$ 1100	1	\$ 1100
3. Cabbage Corer, Portable	1	450			1	450	1	450
4. Bench Platform Scale to 12 kg, Metric & Avoirdupois	1	600	1	\$ 500	1	500	1	500
6. Food Cutter, Counter Top	1	1700	1	1700	1	1700	1	1700
6. Storage Cabinet (lin ft)	4	600	4	600	4	600	4	600
7. Cart (Bakery Rack)	6	1350	3	675	6	1350	6	1350
B. Ingredient Tubs, Stack & Nest (2 ft ³)	16	320	B	160	16	320	16	320
9. Platform Truck for Ingrid. Tubs	2	800			2	800	2	800
10. Mobile Shelving for Container Storage 24"x72" h (lin ft)	4	400	4	400	4	400	4	400
11. Work Counter W/12" Backsplash (lin ft) W/Sinks - 2 Compartments at End W/Disposal in Sink	9	1300			9	1300	9	1300
	Yes				Yes		Yes	
		1360				1350		1350
Subtotal		\$13220		\$ 7385		\$13220		\$13220
Refrigerator Area								
1. Normal Walk-In Refrigerator (35°F) W/St. Steel Mobile Shelves, Dunnage Recks & Carts (sq ft)	500	\$31100	370	\$22700	500	\$31100	500	\$3110
2. Low Temperature Walk-In Refrigerator (-10°F) W/St. Steel Mobile Shelving, Dunnage Recks & Carts (ft ²)	460	\$31900	230	\$18800	460	\$31900	460	\$31900
3. Holding Refrigerator (35°F, 3 Days) Storage Containers					150	9700		
						7840		
4. Holding Refrigerator (16 days, 10°F) Storage Containers			800	54600	330	23100	1100	74800
								39200
6. Blast Freezer-Roll-In (-50°F) Carts					1	2250		
					1	250		
6. Blast Freezer Walk-In (-50°F) Carts							B	6200
							B	2000
7. Pre Cooler Refrigerator (35°F) Walk-In					B	5800	B	5800
8. Tempering Refrigerator (38°F) Roll-In (Compartments) Carts			17	11200			17	11200
			17	4250			17	4250
9. Patient Staging Refrigerator (35°F) Roll-In (Compartments) Carts	2	2650	3	3630	3	3630	3	3630
	2	500	3	750	3	750	3	750
10. Patient Tray Delivery Cart Holding Refrigerator (36°F) (ft ²)			280	17600	280	17600	280	17600
Subtotal		\$86150		\$133530		\$133920		\$228430

TABLE C-8

Equipment List - 550 Beds (cont'd)

	Improved Conven- tional		Convenience		Cook Chill (Bulk)		Ready Foods (Bulk)	
Cold Preparation Area Praportioning								
Salads, Cold Plates, Sandwich Assembly								
1. Steel Counter W/12" Backsplash (lin ft) W/2 Compartment Sinks W/Disposal (1 H.P.) W/Ovar & Under Shelf	15	\$ 2850	14	\$ 2750	15	\$ 2850	15	\$ 2850
2. Mobila Work Table (3 to 4 ft)	8	3200	4	1600	8	3200	8	3200
3. Portioning Conveyor	-		-		-		-	
4. 3' Mobila Supply Cart W/Worktop	9	1800	9	1800	9	1800	9	1800
5. Slivar W/Stand	1	1800	1	1800	1	1800	1	1800
6. Mixar W/Stand (20 qt)	1	1550	1	1550	1	1550	1	1550
7. Refrigerator Reach-In (Compartments)	6	8300	6	6300	6	6300	6	6300
8. Refrigerator, Walk-In (Included In Normal Temp Allocation)								
9. Freezer Raach-In (Compartments)	2	2250	2	2250	2	2250	2	2250
10. Cart (Bakery Rack)	8	1600	8	1600	8	1600	8	1600
11. Container Storage Mobila Shelves (lin ft)	8	900	8	900	8	900	8	900
12. Dish Racks or Dollies	4	500	4	500	4	500	4	500
13. Trash Receptacles	1	50		50		50		50
Subtotal		\$22800		\$21100		\$22800		\$22800
Special Diets/Nourishment Station								
1. Work Counter W/12" Backsplash (lin ft) W/One Compartment Sink W/3 Drawers W/Undercounter Shelf	12	1800	12	1800	12	1800	12	1800
2. Dvarhead 12" Shalf W/Racipe Rail (lin ft)	6	150	6	150	6	150	6	150
3. Blender	1	300	1	300	1	300	1	300
4. Rafrigerator, Roll-In (Cart Capacity)	2	2650	2	2650	2	2650	2	2650
5. Refrigerator, Raach-In (Compartments)	2	2100	2	2100	2	2100	2	2100
6. Portion Scala	1	300	1	300	1	300	1	300
7. Microwave Oven	-		-		-		-	
8. Storage Cabinet (lin ft)	4	800	4	800	4	800	4	800
9. Film Dispenser; Wall-Mountad	1	20	1	20	1	20	1	20
10. Disposable Cup Dispenser, Wall Mount	3	90	3	90	3	90	3	90
11. Label Dispenser, Wall Mount	1	30	1	30	1	30	1	30
12. Utility Cart, Undarcountrar	2	400	2	400	2	400	2	400
13. Trash Receptacle	1	50	1	50	1	50	1	50
14. Hand Sink W/Wrist Blade Faucets	Shared							
Subtotal		\$ 8690		\$ 8690		\$ 8690		\$ 8690

TABLE C-6
Equipment List - 550 Beds (cont'd)

	Improved Conven- tional		Convenience		Cook Chill (Bulk)		Ready Foods (Bulk)
Hot Preparation Area							
1. Range Conventional (Heating Positions)	4	\$ 1200			4	\$ 1200	4 \$ 1200
2. Range Hot Top (lin ft)	4	1900					
3. Range, Griddle Top (lin ft)	5	2600			5	2600	5 2600
4. Broiler-Grill Comb. (lin ft)	4	2100			4	2100	4 2100
5. Oven, Convection (Compartments)	1	1400	3	\$ 4150	4	5500	
6. Oven, Convection Roll-In	2	12000			1	6000	2 12000
7. Fryer W/Spreader, Fat Filter	2	3200			2	3200	2 3200
8. Broiler	-				-		-
9. Braising Pan	1	2150	1	2150	1	2150	1 2150
10. Steamer Convection (Compartments)	1	2600	1	2600	1	2600	1 2600
11. Steamer, Pressure (Compartments)	2	3350	1	1300	1	1300	1 1300
Kettles, Wall-Mounted, Ball Valve Drain							
12. 80-Gal. Tilt	1	5000			2	10000	2 10000
13. 60-Gal. Tilt	1	4600					
14. Mixers for Kettle, Swing Away	1	6000			1	6000	1 6000
15. Metered Cold Water Supply	1	200			1	200	1 200
16. Circulated Cold Water System for Kettle Cooling	-				-		-
17. Floor Grate Drains	Yes		Yes		Yes		Yes
Kettle, Table Top, Tilting, W/Water Supply, Drain Trough, Sliding Dump Tray							
18. 20-Qt Kettle	2	2400	1	1400			
19. 40-Qt Kettle			2	3400	2	3400	2 3400
20. Cook's St. Steel Table (lin ft) W/1 Sink & Disposers W/3 Drawers & Undershelf	10	2000	8	1800	10	2000	10 2000
21. Mobile Work Table	8	1400			8	1400	8 1400
22. Undertable Utility Cart, St. Steel	2	400	1	200	2	400	2 400
23. Pot Rack, Wall-Mounted, 2-Tier (lin ft)	5	250	3	150	5	250	5 250
24. Pan Storage Shelf, Mobile (lin ft)	6	1300	3	650	6	1300	6 1300
25. Cook's Refrigerator, Reach-In (Compartment)	2	2200	2	2200	2	2200	2 2200
26. Cook & Freezer, Reach-In (Compartments)	2	2550	2	2550	2	2550	2 2550
27. Hand Sink W/Wrist Blade Faucets	Yes		Yes		Yes		Yes
28. Exhaust Hood, Self-cleaning With Fire Prot. (lin ft)		45000		16500		42000	

TABLE C-8

Equipment List - 550 Beds (cont'd)

	Improved Conven- tional		Convenience		Cook Chill (Bulk)		Ready Foods (Bulk)	
Hot Preparation Area (cont'd)								
29. Floor Mixer (qt)	80	\$ 3900	80	\$ 3900	80	\$ 3900	80	\$ 3900
30. Slicer on Mobile Stand	1	1800	1	1800	1	1800	1	1800
31. Trash Receptacle	2	100	2	100	2	100	2	100
32. Hot Storage Cabinet, Mobile	2	1400						
Subtotal		\$113000		\$44850		\$104150		\$104650
Baking & Pastry								
1. Ovens, Convection (No of Compartments)	2	2750	3	4200	2	2750	2	2750
2. Ovens, Bake, Rotary - 20-Pan		9400				9400		9400
3. Mixer Kettle W/8 Gall Drain Valve, 40-Gal Tilt	1	6300			1	6300	1	6300
4. Kettle, Table Mount Tilt W/Drain Trough, Sliding Dump Tray & Water Supply (qt)	3	1450			3	1450	3	1450
5. Baker's Range, 2 Burner	1	650			1	650	1	650
6. Fryer W/Donut Attach., Spreader, Fat Filter	1	2700			1	2700	1	2700
7. Floor Grate for Kettles	Yes				Yes		Yes	
8. Exhaust Hood Self-cleaning W/Fire Prot. (lin ft)	60	4500			60	4500	6	4500
9. Baker's Table, 6 ft Maple Top W/3 Drawers	1	750			1	750	1	750
10. St. Steel Work Table (lin ft) W/Sink W/1 Compartment W/Sink W/2 Compartment	10 Yes	1250	8 Yes	950	10 Yes	1250	10 Yes	1250
11. Overshelf W/Recipe Rail (lin ft)	6	50			6	50	6	50
12. Mixer, Floor-Mounted (qt)	80	3900			80	3900	80	3900
13. Mixer W/Stand (qt)	10	1450			10	1450	10	1450
14. Dough Sheeter	1	2300			1	2300	1	2300
15. Pot Rack, Mobile (lin ft)	5	200			5	200	5	200
16. Proof Cabinet	1	5100			1	5100	1	5100
17. Cooling Rack, Butterfly	2	400	2	400	2	400	2	400
18. Cart, Baker Racks	3	750	2	500	3	750	3	750
19. Refrigerator, Reach-In (Compartment)	4	4200			4	4200	4	4200
20. Pie Press	1	200			1	200	1	200
21. Dough Divider	1	1050			1	1050	1	1050
22. Utility Cart, Undercounter	2	400	1	200	2	400	2	400
23. Ingredient Bins	2	200			2	200	2	200
24. Baker's Scale	1	750			1	750	1	750
25. Trash Receptacles	1	50	1	50	1	50	1	50
Subtotal		\$50750		\$6300		\$50750		\$50750

TABLE C-6

Equipment List - 650 Beds (cont'd)

	Improved Conven- tional	Convenience	Cook Chill (Bulk)	Ready Foods (Bulk)
Meat Shop Area				
1. Trim & Trash Receptacles	3	\$ 150	3	\$ 150
2. St. Steel Table W/2 Compartment Sink (lin ft)	10	1300	10	1300
3. W/Built-In Grinder, Undertable	1	1500	1	1500
4. Platform Floor Scale, Mobile	1	1600	1	1600
5. Portable Meat Cutting Table (lin ft) W/Resilient Wood Top	6	850	6	850
6. Portion Scale	1	300	1	300
7. Patty Former	1	1700	1	1700
B. Utility Cart	1	200	1	200
9. Platform Hand Cart	2	300	2	300
10. Hose Station W/Detergent Injector	1	200	1	200
11. Knife Rack, Magnetic	1	100	1	100
12. Hand Sink W/Wrist Blade Controls	1	350	1	350
13. Butcher Paper Dispenser, Wall	1	50	1	50
14. Meat Lugs	8	200	8	200
15. Walk-In Refrigerator Included W/ Allocation				
16. Walk-In Freezer				
Subtotal		\$ 8800	\$ 8800	\$ 8800
Portioning & Packaging				
1. 10' Mobile Portioning Conveyor Shared W/Finish Prep.			-	-
2. Mobile Portioning Table (lin ft)			12	1500
3. Utility Cart			3	600
4. Mobile Cart, Cooler Backup			10	2000
5. Preportioning Scale - Over/Under 10 kg (Bulk Pan)			1	400
8. Tray Conveyor Shared W/PTA				
7. Precooler - Included in Refrigerator Allotment				
8. Blast Freezer			\$ 4500	\$ 4500

TABLE C-8

Equipment List - 650 Beds (cont'd)

	Improved Conven- tional		Convenience		Cook Chill (Bulk)		Ready Foods (Bulk)
Warewashing Area - Pot & Pan							
1. Soak Sink for Pans (24"x24")	1	\$ 500			1	\$ 500	1 \$ 500
2. Pot Sink - 3-Compartment W/Drainboard	1	1200	1	\$ 1200	1	1200	1 1200
3. Scrapping Table W/Disposer & Overhead Rinse Hose (lin ft)	6	1650	5	1550	6	1650	6 1650
4. Transport Racks for Soiled Pans	5	1250	2	500	5	1250	5 1250
5. Pot & Utensil Washer W/Hood & Booster Heater	1	5150			1	5150	1 5150
6. Floor Mats	Yes		Yes		Yes		Yes
Warewashing Area - Dishware							
7. Soiled Dish Bussing Racks	10	4000	10	4000	10	4000	10 4000
8. Dishwasher, Carousel W/Dryer (lin ft)	27	36000	27	36000	27	36000	27 36000
9. Scrapping Table W/Trough Disposer & Overhead Rinse Hose (lin ft)	19	3200	19	3200	19	3200	19 3200
10. Dish Truck	17	10200	17	10200	17	10200	17 10200
11. Rack Dolly, Dishes & Mugs	8	2800	14	4900	14	4900	14 4900
12. Tray Dolly, Single Stack	4	600	7	1050	7	1050	7 1050
13. Soak Sink, Utensils	1	500	1	500	1	500	1 500
14. Utensil Sorting Table (lin ft)	5	550	5	550	5	550	5 550
15. Carts for Soiled Pot Trays	Shared with PTA						
16. Rack Dolly or Dish Truck	-		-		-		-
17. Trash Receptacles	3	150	3	150	3	150	3 150
18. Compactor	-		-		-		-
19. Manual Cartwash W/Detergent Injector	1	650	1	650	1	650	1 650
20. Automatic Cartwash	-		-		-		-
Subtotal		\$68400		\$64450		\$70950	\$70950
Patient Tray Assembly Area							
1. Tray Dispenser (No of Stacks)	4	1200	4	1200	4	1200	4 1200
2. Starter Unit	1	1000	1	1000	1	1000	1 1000
3. Tray Conveyor (No of positions)	13	15400	7	8000	7	8000	7 8000
4. Plate Dispenser (No of Tubes)	-		8	2300	8	2300	8 2300
5. Plate Dispenser, Heated (No of Tubes)	8	3000	-		-		-
6. Veg. Dish Dispenser (No of Tubes)	-		8	1800	8	1800	8 1800
7. Dish Dispenser Heated (No of Tubes)	8	2600	-		-		-
8. Bowl Dispenser (No of Tubes)	8	2600	-		-		-
9. Mug Dispenser (Reck Lowerator)	4	2600	4	2600	4	2600	4 2600
10. Glass Dispenser	4	1800	4	1800	4	1800	4 1800

TABLE C-8

Equipment List - 550 Beds (cont'd)

	Improved Conven- tional		Convenience		Cook Chill (Bulk)		Ready Foods (Bulk)	
Patient Tray Assembly Area (cont'd)								
11. Proportioned Cold Food Rack (Soup-Cold Plate)	8	\$ 1800	9	\$ 1800	9	\$ 1800	9	\$ 1800
12. Cold Food Table (Portioning Wells)			12	4200	12	4200	12	4200
13. Hot Food Table (Portioning Wells)	12	4800						
14. Bread & Ambient Station (Rewrapped)	1	650	1	650	1	650	1	650
15. Toaster	1	400	-	-	-	-	-	-
16. Milk Dispenser (Cooled Lowerator)	2	2000	2	2000	2	2000	2	2000
17. Cold Beverage Station W/Tea, Canned Sode, Juices, Etc.	1	1800	1	1800	1	1800	1	1800
18. Hot Beverage Station W/Coffee Urn	1	1800	1	1800	1	1800	1	1800
19. Ice Maker/Dispenser	1	9000						
20. Ice Cream Dispenser (Frozen Lowerator)	1	1050						
Subtotal		\$543000		\$30950		\$30950		\$30950
Dining Hall Area								
1. Cashier - Heat Count Position Attendant's Chair, Table & Cash System	1	-	1	-	1	-	1	-
2. Tray & Silver Stand, Lowerator (No Stacks)	4	1400	4	1400	4	1400	4	1400
3. Hot Food Counter/Tray Rail, Sneeze Guard (No of Wells)	7	2350	7	2350	7	2350	7	2350
4. Convection Oven (No. of Compartments)			2	2750	2	2750	2	2750
5. Roll-In, Pass Thru - Hot Food Warmer (Single Cart)	1	3500						
6. Plate Lowerator, Heated (No of Tubes)	9	3500	9	3500	9	3500	9	3500
7. Bowl Lowerator, Heated (No of Tubes)	9	3500	9	3500	9	3500	9	3500
8. Vegetable Dish Lowerator, Heated	6	2700	6	2700	6	2700	6	2700
9. Short Order Counter W/Tray Rail & Sneeze Guard (No. of Hot Wells)	4	3100	4	3100	4	3100	4	3100
10. Sandwich Section W/Tray Rail, Sneeze Guard & Cold Wells, Made to Order (lin ft)	8	4200	8	4200	8	4200	8	4200
11. Pass Thru Refrigerator - Holder	-	-	1	2800	1	2800	1	2800
12. Grill Flat Top (lin ft)	6	2700	6	2700	6	2700	6	2700
13. Fryer W/Spreader (No of Wells)	3	3400	3	3400	3	3400	3	3400
14. Exhaust Hood (lin ft)	8	6000	8	6000	8	6000	8	6000
15. Counter Top Steamer (Single Compart)			1	1300	1	1300	1	1300
18. Undercounter Refrigerator	1	2500	1	2500	1	2500	1	2500

TABLE C-6

Equipment List -- 100 Beds (cont'd)

	Improved Conven- tional		Convenience		Cook Chill (Bulk)		Ready Foods (Bulk)	
Dining Hall Area (cont'd)								
17. Undercounter Freezer	1	\$ 2500	1	\$ 2500	1	\$ 2500	1	\$ 2500
18. Workcounter W/Sink (lin ft)	6	1500	6	1500	6	1500	6	1500
19. Handwash Sink	1	250	1	250	1	250	1	250
20. Toaster (No. of Slices)	8	550	8	550	8	550	8	550
21. Beverage Island W/Dispensers for Milk, Carbonated Beverages (4), Cold Beverages (2), Ica Taa, Hot Coffea, Hot Water, Craam, & Hot Chocolate	1	14500	1	14500	1	14500	1	14500
22. Mug & Glass Lowerator (or Disposables Dispenser)	5	2750	5	2750	5	2750	5	2750
23. Condiment Island W/Braad Disp., Buttar Disp., Portion Control Condiments & Dressings, Chilled Water Disp., Glass Lowerator, and Fruit, etc.	1	8100	1	8100	1	8100	1	8100
24. Salad & Dessert Island - Chilled Bottom Shelf W/2 Above Shelves, Undercounter Storage	1	4900	1	4450	1	4450	1	4450
25. Soft Ice Craam Dispenser	1	6000	1	6000	1	6000	1	6000
26. Dish Lowerator for Soft Serva	1	550	1	550	1	550	1	550
27. Cold Pass Thru Refrigerator - Salads & Desserts	2	4100	2	4100	2	4100	2	4100
Subtotal		\$84550		\$87450		\$87450		\$87450
40-Bed Galley Area								
1. Nourishment Station W/ 6' Work Counter 2' Overhead Cabinet Undercounter Storage Hot Water Dispenser Undercounter Refrigerator Undercounter Freezer Work Sink Ice Makar W/Dispenser Trash Receptacla	14	84000	14	84000	14	84000	14	84000
2. Rethermalization Transport Module			56	280000	56	280000	56	280000
Subtotal		\$84000		\$364000		\$364000		\$364000

APPENDIX D
Space Requirements

TABLE D-1
FUNCTIONAL SPACE ALLOTMENTS (FT²) · 100 BEDS

	Improved Conventional	Convenience	Cook-Chill (Bulk)	Ready Foods (Bulk)
Receiving & Shipping	150	150	150	150
Trash	80	80	80	80
Bulk Stores	300	280	300	300
Day Stores & Non Food Stores	180	60	180	180
Issue & Ingredient Area	150	—	150	150
Rough Preparation	150	125	150	150
Refrigeration/Freezing	290	530	460	740
Cold Preparation Area	200	180	200	200
Special Diet/Nourishment Station	100	100	100	100
Hot Preparation Area	350	225	325	325
Baking & Pastry	260	—	260	260
Warewashing	630	630	630	630
Portioning & Packaging	—	—	105	150
Patient Tray Assembly	500	450	450	450
Dining Hall	1,750	1,750	1,750	1,750
Cart Parking/Dish Storage	100	100	100	100
Janitor Closet/Detergent Storage	80	80	80	80
Office Space	<u>650</u>	<u>650</u>	<u>650</u>	<u>650</u>
TOTAL	<u>5,920</u>	<u>5,390</u>	<u>6,120</u>	<u>6,445</u>
Building Costs (\$85 sq. ft.) ⁶	\$503,200	\$458,150	\$520,200	\$547,825

TABLE D-2
FUNCTIONAL SPACE ALLOTMENTS (FT²) -- 250 BEDS

	Improved Conventional	Convenience	Cook-Chill (Bulk)	Ready Foods (Bulk)
Receiving & Shipping	200	200	200	200
Trash	100	100	100	100
Bulk Stores	520	450	520	520
Day Stores & Non Food Stores	310	100	310	310
Issue & Ingredient Area	210	—	210	210
Rough Preparation	220	160	220	220
Refrigeration/Freezing	580	980	1,000	1,515
Cold Preparation Area	250	230	250	250
Special Diet/Nourishment Station	120	120	120	120
Hot Preparation Area	450	300	475	475
Baking & Pastry	320	—	320	320
Meat Shop	180	—	180	180
Warewashing	880	880	880	880
Portioning & Packaging	—	—	150	190
Patient Tray Assembly	700	600	600	600
Dining Hall	2,300	2,300	2,300	2,300
Cart Parking/Dish Storage	230	230	230	230
Janitor Closet/Detergent Storage	90	90	90	90
Office Space	<u>940</u>	<u>1,020</u>	<u>1,020</u>	<u>1,020</u>
TOTAL	<u>8,600</u>	<u>7,760</u>	<u>9,175</u>	<u>9,730</u>
Building Cost (\$85 sq. ft.) ⁶	\$731,000	\$659,600	\$779,875	\$827,050

TABLE D-3

FUNCTIONAL SPACE ALLOTMENTS (FT²) -- 550 BEDS

	Improved Conventional	Convenience	Cook-Chill (Bulk)	Ready Foods (Bulk)
Receiving & Shipping	250	250	250	250
Trash	100	100	100	100
Bulk Stores	990	860	990	990
Day Stores & Non Food Stores	600	200	600	600
Issue & Ingredient Area	250	—	250	250
Rough Preparation	290	195	290	290
Refrigeration/Freezing	1,120	1,800	1,960	2,780
Cold Preparation Area	300	280	300	300
Special Diet/Nourishment Station	150	150	150	150
Hot Preparation Area	575	350	550	550
Baking & Pastry	580	—	580	580
Meat Shop	260	—	260	260
Warewashing	1,320	1,320	1,320	1,320
Portioning & Packaging	—	—	300	340
Patient Tray Assembly	900	750	750	750
Dining Hall	3,700	3,700	3,700	3,700
Cart Parking/Dish Storage	480	480	480	480
Janitor Closet/Detergent Storage	90	90	90	90
Office Space	<u>1,520</u>	<u>1,520</u>	<u>1,520</u>	<u>1,520</u>
TOTAL	<u>13,475</u>	<u>12,045</u>	<u>14,440</u>	<u>15,300</u>
Building Cost (\$85 sq. ft.) ⁶	\$1,145,375	\$1,023,825	\$1,227,400	\$1,300,500

TABLE D-4 DETAILED SPACE REQUIREMENTS (FT²)

	100 BEDS			250 BEDS			550 BEDS					
	Improved Conventional	Convenience	Cook-Chill	Ready Foods	Improved Conventional	Convenience	Cook-Chill	Ready Foods	Improved Conventional	Convenience	Cook-Chill	Ready Foods
		Shared				Shared				Shared		
Receiving Dock	150	150	150	150	200	200	200	200	250	250	250	250
Receiving	40	40	40	40	60	60	60	60	60	60	60	60
Trash	40	40	40	40	40	40	40	40	40	40	40	40
Can Washing												
Bulk Stores	300	280	300	300	520	450	520	520	990	860	990	990
Day Stores	120	-	120	120	210	-	210	210	400	-	400	400
Non-Food Stores	60	60	60	60	100	100	100	100	200	200	200	200
Issue & Ingredient	150	-	150	150	210	-	210	210	250	-	250	250
Normal Temp. Refrigerator	150	110	150	150	260	200	260	260	500	370	500	500
Low Temp. Refrigerator	140	70	140	140	240	120	240	240	460	230	460	460
Pre-Cooler	-	-	20	20	-	-	50	50	-	-	80	80
Blast Freezer	-	-	-	20	-	-	-	50	-	-	-	80
Holding Freezer	-	260	40	320	-	450	140	625	-	800	330	1100
Holding Refrigerator	-	-	60	-	-	-	100	-	-	-	150	-
Tempering Refrigerator	-	40	-	40	-	80	-	80	-	120	-	120
Refrigerated Cart Hold.	-	50	50	50	-	130	130	130	-	280	280	280
Meat Refrigerator	-	-	-	-	50	-	50	50	100	-	100	100
Meat Freezer	-	-	-	-	30	-	30	30	60	-	60	60
Rough Preparation	150	125	150	150	220	160	220	220	290	195	290	290
Finish Preparation	200	180	200	200	250	230	250	250	300	280	300	300
Meat Preparation	-	-	-	-	180	-	180	180	260	-	260	260
Cooking	350	225	325	325	450	300	475	475	575	350	550	550
Bakery	260	-	260	260	320	-	320	320	580	-	580	580
Portion & Packaging	-	-	105	150	-	-	150	190	-	-	300	340
Special Diet/Nourish.	100	100	100	100	120	120	120	120	150	150	150	150

TABLE D-4 DETAILED SPACE REQUIREMENTS (FT²) (Cont'd)

	100 BEDS			250 BEDS			550 BEDS					
	Improved Conventional	Convenience	Cook-Chill	Ready Foods	Improved Conventional	Convenience	Cook-Chill	Ready Foods	Improved Conventional	Convenience	Cook-Chill	Ready Foods
Tray Assembly	500	450	450	450	700	600	600	600	900	750	750	750
Cart Parking	50	50	50	50	130	130	130	130	280	280	280	280
Dish Storage	50	50	50	50	100	100	100	100	200	200	200	200
Offices — Administration	100	100	100	100	120	120	120	120	140	140	140	140
Chief — F.S. Div.	80	80	80	80	80	80	80	80	140	140	140	140
Secy./Clerk/Typist	80	80	80	80	100	100	100	100	120	120	120	120
Chief of Dietetics	80	80	80	80	100	100	100	100	200	200	200	200
Clinical Dietitian	80	80	80	80	100	100	100	100	120	120	120	120
Prod. & Serve NCO	—	—	—	—	100	100	100	100	120	120	120	120
Asst. P & S NCO or	80	80	80	80	80	80	80	80	100	100	100	100
Cook Steward	—	—	—	—	—	80	80	80	80	80	80	80
Dining Hall Super.	80	80	80	80	160	160	160	160	320	320	320	320
Diet Aides	150	150	150	150	200	200	200	200	300	300	300	300
Conference/Classroom	50	50	50	50	50	50	50	50	50	50	50	50
Employee Toilets/Lockers	Shared	Shared	Shared	Shared	Shared	Shared	Shared	Shared	Shared	Shared	Shared	Shared
Janitor's Closet	80	80	80	80	80	80	80	80	120	120	120	120
Cart Washing	550	550	550	550	800	800	800	800	1200	1200	1200	1200
Ware Washing	30	30	30	30	40	40	40	40	40	40	40	40
Detergent Storage	750	750	750	750	900	900	900	900	1300	1300	1300	1300
Dining Hall — Serving	<u>1000</u>	<u>1000</u>	<u>1000</u>	<u>1000</u>	<u>1400</u>	<u>1400</u>	<u>1400</u>	<u>1400</u>	<u>2400</u>	<u>2400</u>	<u>2400</u>	<u>2400</u>
— Dining	5920	5390	6120	6445	8600	7760	9175	9730	13475	12045	14440	15300
Total												

APPENDIX E

Energy Costs

TABLE E-1
ENERGY COSTS

Area	Improved Conventional	Convenience	Cook-Chill (Bulk)	Ready Foods (Bulk)
100 Beds				
Refrigeration	\$714	\$1,214	\$1,390	\$2,214
Hot Preparation	2,944	1,141	2,013	2,013
Dining Hall	25	368	368	368
Carts	-	851	851	851
Total	\$3,683	\$3,574	\$4,622	\$5,446
250 Beds				
Refrigeration	\$1,424	\$2,245	\$3,022	\$4,533
Hot Preparation	5,223	2,037	3,594	3,594
Dining Hall	44	657	657	657
Carts	-	2,212	2,212	2,212
Total	\$6,691	\$7,151	\$9,485	\$10,996
550 Beds				
Refrigeration	\$2,750	\$4,123	\$5,923	\$8,318
Hot Preparation	9,871	3,850	6,793	6,793
Dining Hall	83	1,242	1,242	1,242
Carts	-	4,764	4,764	4,764
Total	\$12,704	\$13,979	\$18,722	\$21,117

APPENDIX F
Projected Costs

TABLE F-2
PROJECTED COSTS -- 250 BEDS

	1977(Base)	Improved Conventional					
		78	79	80	81	82	87
Labor	\$691,275	\$742,302	\$788,074	\$835,293	\$881,567	\$927,017	\$1,169,749
Food	534,123	571,512	611,517	654,323	700,126	749,134	1,050,699
Equipment	4,222	4,509	4,780	6,057	5,330	5,618	7,308
Energy	6,691	7,360	8,096	8,906	9,796	10,776	17,355
Supplies	51,994	55,539	58,848	62,299	65,655	69,200	89,997
Total	\$1,288,305	\$1,381,222	\$1,471,315	\$1,565,878	\$1,662,474	\$1,761,745	\$2,335,108
Cost/Meal	\$2.73	\$2.92	\$3.11	\$3.31	\$3.52	\$3.75	\$4.94
Convenience							
Labor	\$536,778	\$575,339	\$610,017	\$645,413	\$680,062	\$714,230	\$891,343
Food	803,548	859,796	919,982	984,381	1,053,288	1,127,018	1,580,701
Energy	7,151	7,866	8,652	9,518	10,470	11,517	18,548
Supplies	51,994	55,539	58,848	62,299	65,655	69,200	89,997
Total	\$1,399,471	\$1,498,540	\$1,597,499	\$1,701,611	\$1,809,475	\$1,921,965	\$2,580,589
Cost/Meal	\$2.96	\$3.17	\$3.38	\$3.60	\$3.83	\$4.07	\$5.46
Cook-Chill (Bulk)							
Labor	\$621,441	\$666,378	\$706,709	\$747,975	\$788,382	\$828,195	\$1,041,413
Food	534,123	571,512	611,517	654,323	700,126	749,134	1,050,699
Energy	9,485	10,444	11,477	12,625	13,887	15,276	24,602
Supplies	51,994	55,539	58,848	62,299	65,655	69,200	89,997
Total	\$1,217,047	\$1,303,873	\$1,388,551	\$1,477,222	\$1,568,050	\$1,661,805	\$2,206,711
Cost/Meal	\$2.57	\$2.76	\$2.94	\$3.13	\$3.32	\$3.52	\$4.67
Ready Foods (Bulk)							
Labor	\$595,360	\$638,478	\$677,197	\$716,864	\$755,710	\$793,969	\$998,798
Food	523,441	560,082	599,288	641,238	686,124	734,153	1,029,688
Energy	10,996	12,096	13,305	14,836	16,099	17,709	28,521
Supplies	51,994	55,539	58,848	62,299	65,655	69,200	89,997
Total	\$1,181,791	\$1,266,195	\$1,348,638	\$1,435,037	\$1,523,588	\$1,615,031	\$2,147,004
Cost/Meal	\$2.50	\$2.68	\$2.85	\$3.04	\$3.22	\$3.42	\$4.54

TABLE F-3

PROJECTED CDSTS - 550 BEDS

	Improved Conventional						
	1977(Base)	78	79	80	81	82	87
Labor	\$1,193,467	\$1,282,110	\$1,361,466	\$1,443,756	\$1,524,425	\$1,603,570	\$2,025,869
Food	1,010,503	1,081,238	1,156,925	1,237,910	1,324,563	1,417,283	1,987,812
Equipment	9,221	9,848	10,439	11,044	11,641	12,269	15,960
Energy	12,704	13,974	15,372	16,909	18,600	20,460	32,951
Supplies	98,397	105,074	111,334	117,862	124,211	130,918	170,265
Total	\$2,324,262	\$2,492,244	\$2,655,536	\$2,827,481	\$3,003,440	\$3,184,500	\$4,229,587
Cost/Meal	\$2.60	\$2.79	\$2.97	\$3.16	\$3.36	\$3.56	\$4.73
	Convenience						
Labor	\$853,322	\$914,905	\$970,649	\$1,027,912	\$1,084,006	\$1,139,198	\$1,265,051
Food	1,520,225	1,626,641	1,740,506	1,862,341	1,992,705	2,132,195	2,990,513
Energy	13,979	15,377	16,915	18,606	20,467	22,573	36,258
Supplies	98,397	105,074	111,334	117,862	124,211	130,918	170,265
Total	\$2,485,923	\$2,661,997	\$2,839,404	\$3,026,721	\$3,221,389	\$3,424,884	\$4,462,087
Cost/Meal	\$2.78	\$2.98	\$3.18	\$3.38	\$3.60	\$3.83	\$4.99
	Cook-Chill (Bulk)						
Labor	\$1,107,121	\$1,188,466	\$1,281,742	\$1,337,547	\$1,411,847	\$1,484,793	\$1,640,751
Food	1,010,503	1,081,238	1,156,925	1,237,910	1,324,563	1,417,283	1,987,812
Energy	18,722	20,594	22,654	24,919	27,411	30,152	48,560
Supplies	98,397	105,074	111,334	117,862	124,211	130,918	170,265
Total	\$2,234,743	\$2,395,372	\$2,552,655	\$2,718,238	\$2,888,032	\$3,063,146	\$3,847,388
Cost/Meal	\$2.50	\$2.68	\$2.85	\$3.04	\$3.23	\$3.43	\$4.30
	Ready Foods (Bulk)						
Labor	\$1,055,226	\$1,132,760	\$1,202,658	\$1,275,005	\$1,345,916	\$1,415,526	\$1,563,673
Food	990,293	1,059,614	1,113,786	1,213,152	1,298,072	1,388,937	1,948,056
Energy	21,117	23,228	25,552	28,107	30,917	34,009	54,772
Supplies	98,397	105,074	111,334	117,862	124,211	130,918	170,265
Total	\$2,165,033	\$2,320,676	\$2,473,330	\$2,634,126	\$2,799,116	\$2,969,390	\$3,736,766
Cost/Meal	\$2.42	\$2.60	\$2.77	\$2.95	\$3.13	\$3.32	\$4.18

APPENDIX G
Operating Data-Summer 1977

Table G-1 is a composite of the data of those hospitals operating at workload levels approximately equivalent to 100-, 250-, and 550-bed hospitals (i.e., 11,192 monthly meals, 39,368 monthly meals, 74,480 monthly meals, respectively). The second section contains the complete set of baseline data on current operations that was collected by questionnaire. The monthly data is for Army hospital food service operations and was collected during the Summer, 1977.

TABLE G-1

HOSPITAL FOODSERVICE WORKLOADS - SUMMER 1977

Hospital	Avg Patient Load	Monthly Meal Workload		Total Meals
		Patient	Nonpatient	
a. 100-Bed				
Carson MEDDAC	106	11,212	8,738	19,950
Darnell MEDDAC	172	17,834	6,496	24,330
DeWitt MEDDAC	70	5,399	12,421	17,820
Ft. Campbell MEDDAC	173	17,652	8,268	25,920
Ireland MEDDAC	148	14,792	11,158	25,950
Irwin MEDDAC	83	8,424	8,946	17,370
Leonard Wood MEDDAC	159	17,718	6,822	24,540
Reynolds MEDDAC	114	11,549	16,081	27,630
Walson MEDDAC	176	20,286	6,834	27,120
Avg	133	13,874	9,529	23,403
Concept Analysis	100	8,655	13,537	22,192
b. 250-Bed				
Eisenhower MEDCEN	256	32,656	11,534	44,190
Fitzsimons MEDCEN	550	21,041	16,939	37,980
Hayes MEDDAC	411	14,256	18,744	33,000
Madigan MEDCEN	283	24,646	10,664	35,310
Monticief MEDDAC	231	23,424	9,246	32,670
Womack MEDDAC	259	26,013	9,867	35,880
Avg	332	23,673	12,832	36,505
Concept Analysis	250	21,652	17,716	39,368
c. 550-Bed				
Beaumont	447	47,110	17,780	64,890
Walter Reed	675	81,388	9,752	91,140
Avg	561	64,249	13,766	78,015
Concept Analysis	550	45,433	29,047	74,480

**Composite Hospitals Operating At Time
Level Of The Concept Analysis**

100 BED

ANALYSIS OF - CONSOLIDATION -9 HDSPS
 MONTH OF 577
 AVG WEEKDAY CENSUS 1201

FOOD SERVICE STAFF

TOTAL EMPLOYEES	555
FROM THE TOA	
SUPERVISORS	86
COOKS	137
FOOD SERV WORKERS	254
STOREROOM	18
MEATCUTTERS	14
BAKERS	14
DIET AIDS	26
CLINICAL DIETICIANS	15
OTHER WORKERS	30

MEAL DISTRIBUTION

INPATIENT MEAL/MONTH	100080.0
OTHER MEAL/MONTH	110550.0
TOTAL MEALS/MONTH	210630.0

PERCENT IMPATIENT MEALS	47.5
PERCENT PATIENT MEALS IN OH	10.7
PERCENT PATIENT SPECIAL DIETS	22

LABOR COST	DOLLARS	MONTHLY COST ANALYSIS	COST/MEAL	INVENTORY TURNOVER RATE
FOOD COST	659163.00	PERCENT	3.13	
SUPPLY COST	246592.00		1.17	1.22
OTHER COST	19674.00		.09	.15
TOTAL COST	1662.00		.01	
	927091.00		4.40	

MONTHLY BAKING-MEATCUTTING SUMMARY

COST	BAKING	MEATCUTTING
LABOR	14220.10	15432.70
FOOD	10392.00	97346.00
TOTAL	24612.10	112778.70
COST/MEAL	.12	.54
NUMBER OF WORKERS	14	14

250 BED

ANALYSIS OF - CONSOLIDATION -6 HOSPS
 MONTH OF 377
 AVG WEEKDAY CENSUS 1990

FOOD SERVICE STAFF

TOTAL EMPLOYEES	503
FROM THE TOA	76
SUPERVISORS	93
COOKS	222
FOOD SERV WORKERS	20
STOREROOM	9
MEATCUTTERS	10
BAKERS	30
DIET AIDS	19
CLINICAL DIETICIANS	27
OTHER WORKERS	

MEAL DISTRIBUTION	
INPATIENT MEAL/MONTH	103440.0
OTHER MEAL/MONTH	115590.0
TOTAL MEALS/MONTH	219030.0
PERCENT INPATIENT MEALS	47.2
PERCENT PATIENT MEALS IN DH	16.7
PERCENT PATIENT SPECIAL DIETS	24

LABOR COST	DOLLARS	MONTHLY COST ANALYSIS	INVENTORY TURNOVER RATE
603989.00		PERCENT	
257297.00		68.36	2.76
22259.00		29.12	1.17
20.00		2.52	1.35
883565.00		.00	.60
			4.03

MONTHLY BAKING-MEATCUTTING SUMMARY

COST	BAKING	MEATCUTTING
LABOR	10341.50	10311.40
FOOD	5805.00	109774.00
TOTAL	15946.50	120085.40
COST/MEAL	.07	.55
NUMBER OF WORKERS	10	9

550 BED

ANALYSIS OF - CONSOLIDATION -2 HOSPS
 MONTH OF 377
 AVG WEEKDAY CENSUS 1122

FOOD SERVICE STAFF

TOTAL EMPLOYEES FROM THE TOA	349
SUPERVISORS	42
COOKS	47
FOOD SERV WORKERS	191
STOREROOM	20
MEATCUTTERS	5
BAKERS	3
DIET AIDS	30
CLINICAL DIETICIANS	17
OTHER WORKERS	39

MEAL DISTRIBUTION

INPATIENT MEAL/MONTH	92550.0
OTHER MEAL/MONTH	63480.0
TOTAL MEALS/MONTH	156030.0

PERCENT INPATIENT MEALS	59.3
PERCENT PATIENT MEALS IN DM	21.7
PERCENT PATIENT SPECIAL DIETS	30

LABOR COST	368757.00	DOLLARS
FOOD COST	168548.00	
SUPPLY COST	17265.00	
OTHER COST	100.00	
TOTAL COST	554670.00	

MONTHLY COST ANALYSIS		
PERCENT	66.48	COST/MEAL
	30.39	1.08
	3.11	.11
	.02	.00
		3.55

INVENTORY TURNOVER RATE	1.43
	.15

MONTHLY BAKING-MEATCUTTING SUMMARY

COST	
LABOR	8135.60
FOOD	21844.00
TOTAL	29979.60
COST/MEAL	.19
NUMBER OF WORKERS	3

BAKING	9468.60
MEATCUTTING	63737.00
TOTAL	73205.60
COST/MEAL	.47
NUMBER OF WORKERS	5

All Hospitals

ANALYSIS OF - CONSOLIDATION-100 BEDS
 MONTH OF 677
 AVG WEEKDAY CENSUS 1512

FOOD SERVICE STAFF

TOTAL EMPLOYEES	841
FROM THE TDA	
SUPERVISORS	145
COOKS	225
FOOD SERV WORKERS	346
STOREROOM	30
MEATCUTTERS	19
BAKERS	22
DIET AIDS	33
CLINICAL DIETICANS	25
OTHER WORKERS	56

MEAL DISTRIBUTION

INPATIENT MEAL/MONTH	121680.0
OTHER MEAL/MONTH	171210.0
TOTAL MEALS/MONTH	292890.0

166

PERCENT INPATIENT MEALS	41.5
PERCENT PATIENT MEALS IN OH	7.3
PERCENT PATIENT SPECIAL DIETS	33

LABOR COST	DOLLARS	MONTHLY COST ANALYSIS	COST/MEAL	INVENTORY TURNOVER RATE
FOOD COST	947332.00	PERCENT	3.23	
SUPPLY COST	330663.00		1.13	.34
OTHER COST	34341.00		.12	.29
TOTAL COST	2247.00		.01	
	1314583.00		4.49	

MONTHLY BAKING-MEATCUTTING SUMMARY

COST	BAKING	MEATCUTTING
LABOR	22385.80	22157.90
FOOD	14638.00	132945.00
TOTAL	37023.80	155102.90
COST/MEAL	.13	.53
NUMBER OF WORKERS	22	15

ANALYSIS OF - CONSOLIDATION-250 BEDS
 MONTH OF 477
 AVG WEEKDAY CENSUS 1723

FOOD SERVICE STAFF

TOTAL EMPLOYEES	548
FROM THE IOA	
SUPERVISORS	92
COOKS	103
FOOD SERV WORKERS	229
STOREROOM	18
MEATCUTTERS	9
BAKERS	12
DIET AIOS	37
CLINICAL DIETICANS	20
OTHER WORKERS	42

MEAL DISTRIBUTION

INPATIENT MEAL/MONTH	139710.0
OTHER MEAL/MONTH	118580.0
TOTAL MEALS/MONTH	258290.0
PERCENT INPATIENT MEALS	54.5
PERCENT PATIENT MEALS IN DH	15.0
PERCENT PATIENT SPECIAL DIETS	25

MONTHLY COST ANALYSIS		
DOLLARS		
LABOR COST	684427.00	
FOOD COST	287138.00	
SUPPLY COST	22261.00	
OTHER COST	1186.00	
TOTAL COST	975012.00	
PERCENT	68.15	
COST/MEAL	2.59	
INVENTORY TURNOVER RATE	1.30	
PERCENT	29.45	
COST/MEAL	1.12	
INVENTORY TURNOVER RATE	1.30	
PERCENT	2.28	
COST/MEAL	.09	
INVENTORY TURNOVER RATE	.22	
PERCENT	.12	
COST/MEAL	.00	
INVENTORY TURNOVER RATE	3.80	

MONTHLY BAKING-MEATCUTTING SUMMARY

COST		
LABOR		
FOOD	12921.50	BAKING
TOTAL	7258.00	MEATCUTTING
COST/MEAL	20179.50	1188.60
NUMBER OF WORKERS	.08	128440.00
	.08	139628.60
	12	.54
	9	

ANALYSIS OF - CONSOLIDATION-550 BEDS
 MONTH OF 677
 AVG WEEKDAY CENSUS 2583

FOOD SERVICE STAFF

TOTAL EMPLOYEES	698
FROM THE TDA	
SUPERVISORS	68
COOKS	104
FOOD SERV WORKERS	340
STOREROOM	32
MEATCUTTERS	11
BAKERS	8
DIET AIDS	42
CLINICAL DIETICIANS	33
OTHER WORKERS	60

MEAL DISTRIBUTION

168	INPATIENT MEAL/MONTH	149850.0
	OTHER MEAL/MONTH	130170.0
	TOTAL MEALS/MONTH	280020.0
	PERCENT INPATIENT MEALS	53.5
	PERCENT PATIENT MEALS IN OH	18.3
	PERCENT PATIENT SPECIAL DIETS	29

LABOR COST	759082.00	ODOLLARS	
FOOD COST	323066.00	PERCENT	68.06
SUPPLY COST	33033.00		28.97
OTHER COST	100.00		2.96
TOTAL COST	1115281.00		.01
		MONTHLY COST ANALYSIS	
		COST/MEAL	2.71
		PERCENT	68.06
		INVENTORY TURNOVER RATE	1.31
			.26

MONTHLY BAKING-MEATCUTTING SUMMARY

COST		BAKING		MEATCUTTING	
LABOR		13553.60		15007.00	
FOOD		24790.00		122849.00	
TOTAL		38343.60		137856.00	
COST/MEAL		.14		.49	
NUMBER OF WORKERS		8		11	

ANALYSIS OF - CONSOLIDATION 33 HOSPS
 MONTH OF 577
 AVO WEEKDAY CENSUS 5818

FOOD SERVICE STAFF

TOTAL EMPLOYEES	2087
FROM THE TDA	
SUPERVISORS	325
COOKS	432
FOOD SERV WORKERS	915
STOREROOM	80
MEATCUTTERS	39
BAKERS	42
DIET AIDS	112
CLINICAL DIETICIANS	178
OTHER WORKERS	158

MEAL DISTRIBUTION

INPATIENT MEAL/MONTH	411240.0
OTHER MEAL/MONTH	417960.0
TOTAL MEALS/MONTH	829200.0

PERCENT INPATIENT MEALS	49.6
PERCENT PATIENT MEALS IN OH	11.0
PERCENT PATIENT SPECIAL DIETS	31

		MONTHLY COST ANALYSIS		INVENTORY TURNOVER RATE	
		PERCENT	COST/MEAL		
LABOR COST	DOLLARS	69.63	2.86		
FOOD COST	2370831.00	27.63	1.13		.68
SUPPLY COST	940867.00	2.63	.11		.26
OTHER COST	89635.00	.10	.00		
TOTAL COST	3633.00		4.11		
TOTAL COST	3404876.00				

MONTHLY BAKING-MEATCUTTING SUMMARY

COST		NUMBER OF WORKERS	
LABOR	BAKING	42	
FOOD	MEATCUTTING		39
TOTAL			
COST/MEAL			

APPENDIX H
Statistical Analysis of
Consumer Acceptability Ratings

PROBLEM TITLEFOOD BY PREP BY OVEN WITH CONTROL COVARIED OUT

NUMBER OF VARIABLES TO READ IN. 7
 NUMBER OF VARIABLES ADDED BY TRANSFORMATIONS. 0
 TOTAL NUMBER OF VARIABLES 7
 NUMBER OF CASES TO READ IN. 800
 CASE LABELING VARIABLES
 LIMITS AND MISSING VALUE CHECKED BEFORE TRANSFORMATIONS
 BLANKS ARE. ZEROS
 INPUT UNIT NUMBER 10
 REWIND INPUT UNIT PRIOR TO READING. YES

INPUT FORMAT
 (2F2.0,2X.5F2.0)

VARIABLES TO BE USED
 1 FOOD 2 PREP 3 MICRO 4 CONVEC 5 CONDOC
 6 INFRA 7 CONTRL

DESIGN SPECIFICATIONS

GROUP = 1 2
 DEPENO = 3 4 5 6
 COVAR = 7 7 7 7

ANALYSIS OF VARIANCE FOR 1-ST DEPENDENT VARIABLE

SOURCE	SUM OF SQUARES	DEGREES OF FREEDOM	MEAN SQUARE	F	PROB. F EXCEEDED	BETA ESTIMATES
MEAN	1267.90558	1	1267.90558	208.49924	.000	
F	825.20447	9	91.68938	15.07775	.000	
P	9.78265	2	4.89133	.80435	.448	
FP	449.11877	18	24.95104	4.10304	.000	
1-ST COVAR	508.66983	1	508.66983	83.64781	.000	.31994
ERROR	8460.14813	569	8.08110			
O	10.14331	3	3.38110	2.06241	.103	
OF	159.05643	27	5.89098	3.59338	.000	
OP	12.02911	6	2.00485	1.22292	.291	
OPF	116.89529	54	2.16473	1.32044	.000	
ERROR	2803.37073	1710	1.63940			

POOLED REGRESSION COEFFICIENTS

1-ST COVARIATE -31994

PROBLEM TITLE STARCH BY PREP BY OVEN WITH CONTROL COVARIED OUT

NUMBER OF VARIABLES TO READ IN. 7
 NUMBER OF VARIABLES ADDED BY TRANSFORMATIONS. 0
 TOTAL NUMBER OF VARIABLES 7
 NUMBER OF CASES TO READ IN. 120
 CASE LABELING VARIABLES
 LIMITS AND MISSING VALUE CHECKED BEFORE TRANSFORMATIONS
 ERRORS ARE. ZEROS
 INPUT UNIT NUMBER 10
 REWIND INPUT UNIT PRIOR TO READING. NO

INPUT FORMAT
 (2F2.0.2X.SF2.0)

VARIABLES TO BE USED
 1 FOOD 3 MICRO 4 CONVEC 5 CONDOC
 6 INFRA 7 CONTRL

DESIGN SPECIFICATIONS

GROUP = 1 2
 DEPEND = 3 4 5 6
 COVAR = 7 7 7 7

ANALYSIS OF VARIANCE FOR 1-ST DEPENDENT VARIABLE

SOURCE	SUM OF SQUARES	DEGREES OF FREEDOM	MEAN SQUARE	F	PROB. F EXCEEDED	BETA ESTIMATES
MEAN	232.06062	1	232.06062	45.07429	.000	
F	442.00603	1	442.00603	85.85303	.000	
P	64.87714	2	32.43857	6.30070	.003	
FP	5.49967	2	2.74984	.53411	.588	
1-ST COVAR	138.63023	1	138.63023	28.92684	.000	.34340
ERROR	581.76958	113	5.14840			
O	8.55000	3	2.85000	2.00803	.113	
OF	14.71666	3	4.90555	3.45832	.017	
OP	13.29999	6	2.21667	1.56180	.157	
OPF	13.53332	6	2.25555	1.58920	.149	
ERROR	485.39885	342	1.41930			

ADJUSTED REGRESSION COEFFICIENTS

1-ST COVARIATE .34340

PROBLEM TITLE VEGETABLE BY PHEP BY OVEN WITH CONTROL COVARIED OUT

NUMBER OF VARIABLES TO READ IN 7
 NUMBER OF VARIABLES ADDED BY TRANSFORMATIONS 0
 TOTAL NUMBER OF VARIABLES 7
 NUMBER OF CASES TO READ IN 120
 CASE LABELING VARIABLES
 LIMITS AND MISSING VALUE CHECKED BEFORE TRANSFORMATIONS
 GLA'S ARE ZEROS
 INPUT UNIT NUMBER 10
 REWIND INPUT UNIT PRIOR TO READING NO

INPUT FORMAT
 (2F2.0.2X.5F2.0)

VARIABLES TO BE USED
 1 FOOD 2 PREP 3 MICRO 4 CONVEC 5 CONDOC
 6 INFRA 7 CONTRL

DESIGN SPECIFICATIONS

GROUP # 1 2
 DEPENO = 3 4 5 6
 COVAR = 7 7 7 7

ANALYSIS OF VARIANCE FOR 1-ST DEPENDENT VARIABLE

SOURCE	SUM OF SQUARES	DEGREES OF FREEDOM	MEAN SQUARE	F	PROB. F EXCEEDED	BETA ESTIMATES
MEAN	109.95208	1	109.95208	17.60366	.000	
F	51.95844	1	51.95844	6.31871	.005	
P	38.10716	2	19.05358	3.05054	.051	
FP	14.41283	2	7.20642	1.15377	.319	
1-ST COVAR	106.47999	1	106.47999	17.04779	.000	.42162
ERROR	705.79477	113	6.24597			
O	25.71666	3	8.57222	5.26210	.001	
OF	4.94999	3	1.65000	1.01671	.385	
OP	4.22082	6	.70347	.43347	.856	
OFF	15.58749	6	2.59791	1.60081	.146	
ERROR	555.02480	342	1.62268			

POOLED REGRESSION COEFFICIENTS

1-ST COVARIATE .42162

PROBLEM TITLE BREAKFAST ENTREE BY PREP BY OVEN WITH CONTROL COVARIED OUT

NUMBER OF VARIABLES TO READ IN. 7
 NUMBER OF VARIABLES ADDED BY TRANSFORMATIONS. 0
 TOTAL NUMBER OF VARIABLES 7
 NUMBER OF CASES TO READ IN. 120
 CASE LABELING VARIABLES
 LIMITS AND MISSING VALUE CHECKED BEFORE TRANSFORMATIONS
 BLANKS ARC. ZEROS
 INPUT UNIT NUMBER 10
 REMIND INPUT UNIT PRIOR TO READING. NO

INPUT FORMAT
 (2F2.0,2X,5F2.0)

VARIABLES TO BE USED
 1 FOOD 3 MICRO 4 CONVEC 5 CONDOC
 6 INFRA 7 CONTRL

DESIGN SPECIFICATIONS

GROUP = 1 2
 OEPENO = 3 4 5 6
 COVAR = 7 7 7 7

ANALYSIS OF VARIANCE FOR 1-ST DEPENDENT VARIABLE

SOURCE	SUM OF SQUARES	DEGREES OF FREEDOM	MEAN SQUARE	F	PROB. F EXCEEDED	BETA ESTIMATES
MEAN	381.91052	1	381.91052	51.59488	.000	
F	.23225	1	.23225	.03138	.860	
P	57.48418	2	28.74209	3.88296	.023	
FP	11.92655	2	5.96328	.80562	.449	
1-ST COVAR	77.01233	1	77.01233	10.40412	.002	.24033
ERROR	936.43739	113	7.40210			
O	75.77498	3	25.25832	13.02231	.000	
OF	10.71668	3	3.57222	1.84171	.139	
OP	14.13748	6	2.35625	1.21480	.298	
OPF	18.02081	6	3.00347	1.54848	.162	
ERROR	663.34981	342	1.93962			

COOLED REGRESSION COEFFICIENTS

1-ST COVARIATE .24033

PRD9:EM TITLEMAIN ENTREE BY PREP BY DVEN WITH CONTROL COVARIED OUT

NUMBER OF VARIABLES TO READ IN. 7
 NUMBER OF VARIABLES ADDED BY TRANSFORMATIONS. 0
 TOTAL NUMBER OF VARIABLES 7
 NUMBER OF CASES TO READ IN. 7
 CASE LABELING VARIABLES 240
 LIMITS AND MISSING VALUE CHECKED BEFORE TRANSFORMATIONS
ZERDS
 INPUT UNIT NUMBER 10
 READ INPUT UNIT PRIOR TO READING. YES

INPUT FORMAT
 (2F2.0.2X.5F2.0)

VARIABLES TO BE USED
 1 FOOD 3 MICRO 4 CONVEC 5 CONDOC
 6 INFRA 7 CONTRL

DESIGN SPECIFICATIONS

GROUP = 1 2
 DEPENO = 3 4 5 8
 CDVAR = 7 7 7 7
 LEVEL = 4

ANALYSIS OF VARIANCE FOR 1-ST DEPENDENT VARIABLE

SOURCE	SUM OF SQUARES	DEGREES OF FREEDOM	MEAN SQUARE	F	PROB. F EXCEEDED	BETA ESTIMATES
MEAN	514.06497	1	514.06497	88.35722	.000	
F	122.36919	3	40.78973	7.01092	.000	
P	4.20450	2	2.10225	.36133	.697	
FP	268.87663	6	44.81277	7.70240	.000	
1-ST COVAR	202.00618	1	202.00618	34.72072	.000	.32943
ERROR	1320.69284	227	5.81803			
Q	10.03749	3	3.34583	2.08128	.101	
OF	18.73746	8	2.34219	1.29506	.238	
OP	26.41873	6	4.40312	2.73884	.012	
OFF	23.70618	18	1.31701	.81924	.678	
ERROR	1099.58827	684	1.60760			

COELED REGRESSION COEFFICIENTS

1-ST COVARIATE .32943

APPENDIX I
Dayroom/Dining Area Designs

Behavioral Considerations. A discussion of behavioral and psychological requirements is typically not found when a design solution is presented. In this case, however, the patient is a captive occupant and several behavioral requirements need to be appraised.

a. **Social Interaction.** One of the major purposes of the dayroom dining area is to encourage patients to leave their rooms. With more and more privacy provided in the rooms, patients are offered an opportunity for a greater degree of social interaction in the dayroom dining area. Socialization for individuals and small groups is emphasized through the lack of visual screens and the inclusion of lightweight and mobile furniture.

b. **Choice.** Rather than having the space dictate the allowable activities through the use of partitions, immovable fixtures, and heavy furniture, the patients using the dayroom dining area are afforded a wide variety of choices of activities that can be accommodated. At meal times there is a choice of table size and shape, a choice of chair style and its fabric and color, and a choice of sitting alone or with up to three other patients. During non-meal hours patients can socialize, read, watch television (where provided), use the tables for various activities, or simply sit on a sofa.

c. **Flexibility.** Many coexisting activities can occur simultaneously in the dayroom without interfering with each other. Table heights can be adjusted and the furniture can be rearranged so that the space is defined by the activity rather than by the furnishings.

d. **Stimulation.** Extremes are avoided but colors, textures, styles, and flexibility make the dayroom dining areas interesting and different.

Design Consideration.

a. **Size.** The square footage of the proposed design solutions is approximately that of a four-bed ward common to Army hospitals. Room depth in hospitals (measured from corridor wall to exterior wall) varies from 18 to 26 feet. An average of 22 feet is used as the width for the planning the dayroom dining areas. Pantries/galleys have been located contiguous to the dayroom and are sized to accommodate typical ward galley equipment and food carts.

b. **Location.** Two interior room alternatives and two corner room alternatives are given as dayroom dining areas. The room concepts are assumed to be on a peripheral corridor to maximize the amount of natural light and to provide a view from windows.

c. **Comfort.** Three areas define comfort: (1) temperature and air quality, (2) noise level, and (3) safety. In answer to these considerations, DoD instructions suggest a temperature of 70°F for dining areas. Standard air purification and ventilation systems of the hospital should be sufficient but smoking zones might be considered. Noises are attenuated through the use of carpet, drapery, and upholstery fabrics, and standard safety features are observed.

d. **Color.** The recommended color schemes are a departure from traditional Army hospital decor. The color schemes are based on the color of the painted walls with neutral colors used on all but one accent wall and with complementary colors provided by carpet, draperies, and furniture. The use of more stimulating colors makes the atmosphere of the dayroom dining areas more like a restaurant or lounge than a hospital.

a. **Lighting.** Maximum use of natural light is provided by the windows on the exterior walls which are augmented by two artificial lighting systems. Drapery materials are used to filter sunlight, to soften the hardness of the wall surface, and also to attenuate sound. For lighting systems, rheostatic devices are used to control light levels during non-daylight hours.

f. **Furniture.** The furniture selected for the design solutions meets several criteria: (1) seating is light enough to be easily moved into various arrangements, (2) designs are simple so as not to make the space too "busy" or to dominate it, (3) upholstery fabric is durable and easily cleaned, (4) seating is comfortable for extended period of time, (5) design is aesthetically pleasing to give patients a sense of comfort and class, and (6) the seating arrangement allows patients with restricted mobility to seat themselves and rise easily.

Design Solutions

The layouts, Figures 1-1 and 1-2, show the floor plans of the dayroom dining areas, the location of the galleys and the furniture arrangement (for dining purposes). The color renderings which follow represent an artist's conception of the finished rooms and their color schemes; and the accompanying color charts illustrate the suggested fabrics and materials.

a. **Layouts.** The floor plans illustrate the clusterings of furniture within the space. In all solutions, the galley has been located adjacent to the corridor so that food carts can be easily moved in and out during meal hours and that bed patients can be served from the galley area. These layouts can be readily changed (i.e., opened) in this galley area to provide more floor space if size requirements for equipment are reduced.

b. **Renderings.** In the colored sketches, the artist shows how the dayroom dining areas can look when completed. The accompanying color information describes the fabrics and materials by grade, color, and type.

Utilization Considerations

Appearance, behavioral constraints, and design constraints are all important considerations. However, the success of the dayroom dining areas will be measured by how well this area functions for users (i.e., both patients and health care personnel). The functional considerations which affect proper utilization are:

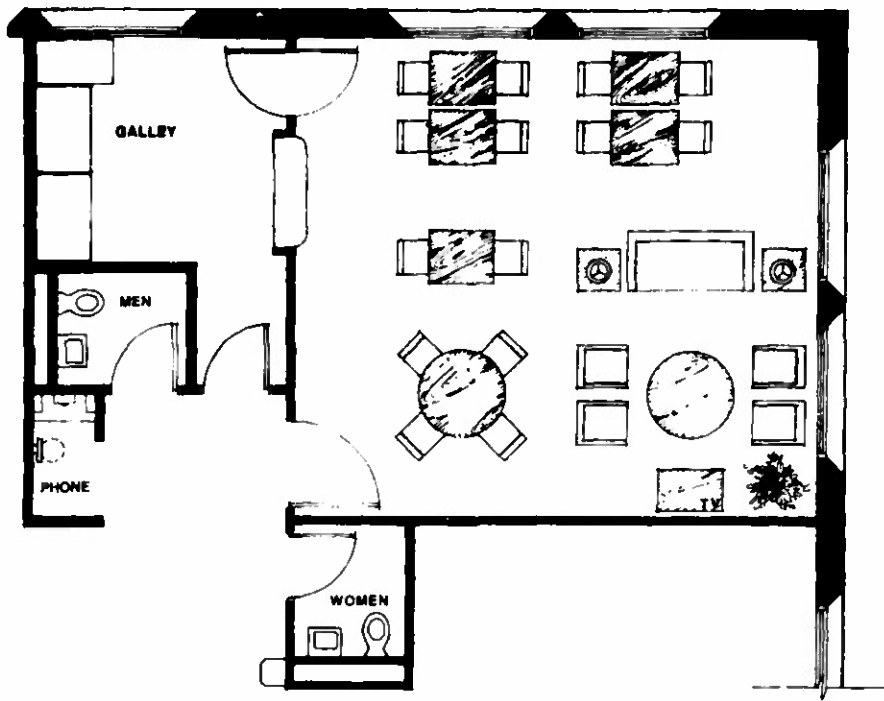

Alternative A

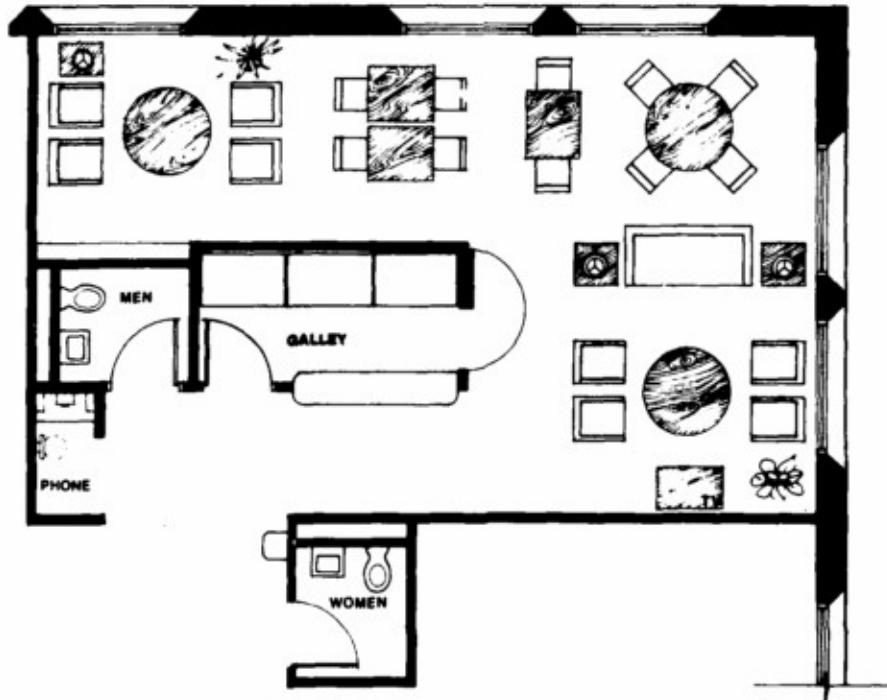
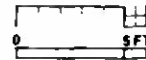

Alternative B



Figure I-1. Deyroom and Dining Area Corner Room

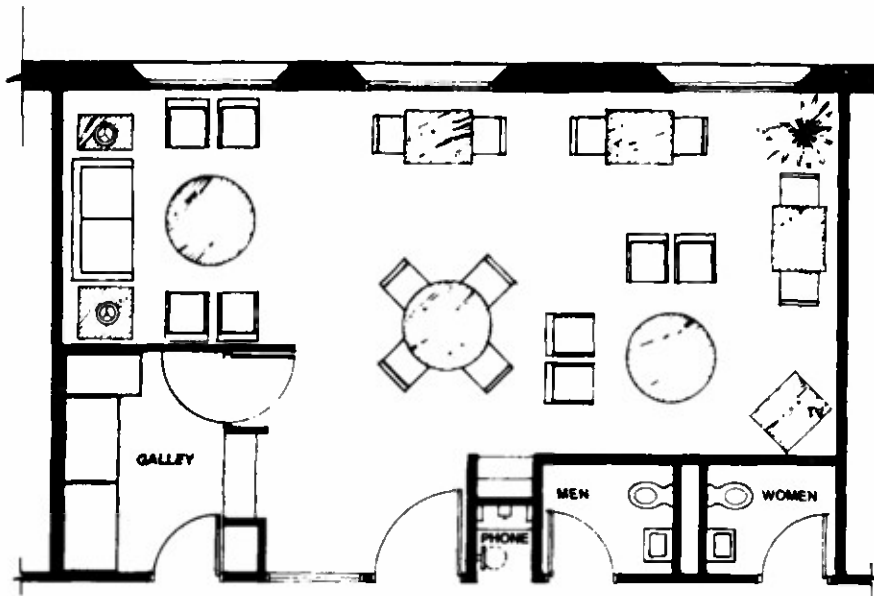

Alternative A

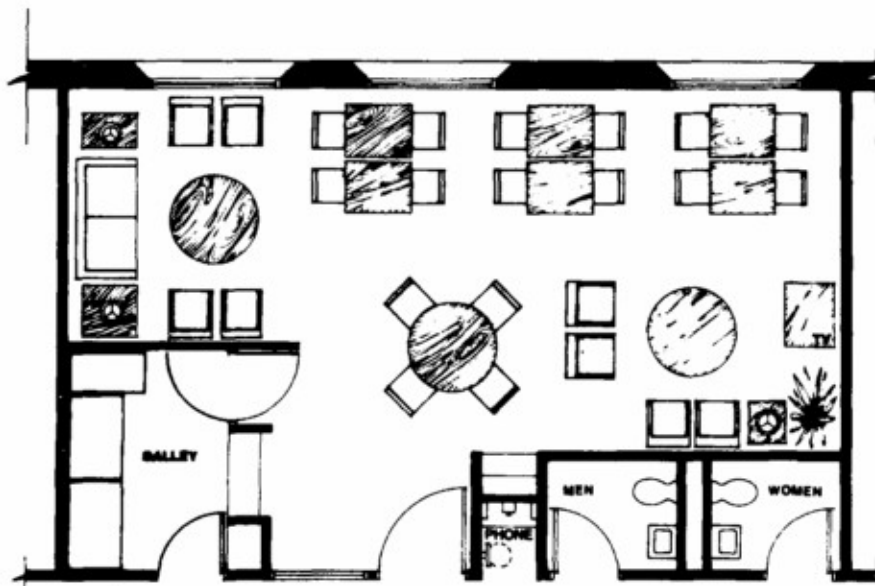

Alternative B

Figures 1-2. Dayroom and Dining Area Interior Room

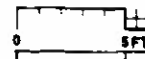



DAYROOM



DINING



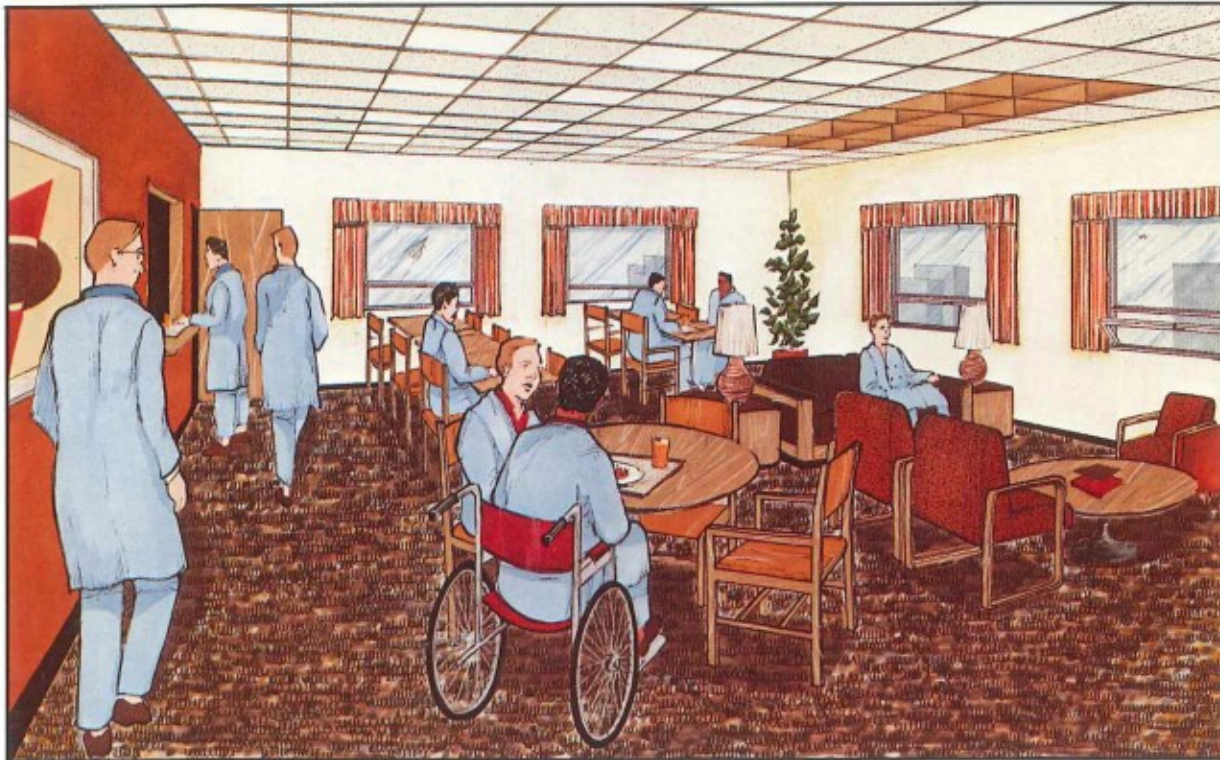

CORNER ROOM, ALTERNATIVE A: BROWN/ORANGE SCHEME

COLOR SCHEDULE: BROWN/ORANGE SCHEME

- A. CARPET:
1. Milliken: 1979 Office Park; 3 Natural Brown
 2. Bigelow: Regents Stripe; 2J11-52819; Spice Brown Stripe
- B. WALL COLORS:
1. PRIMARY WALL COLOR: Federal Standard 595a#27778 Off white
 2. ACCENT WALL COLORS:
 - a. Federal Standard 595a#32169 Rust
 - b. Federal Standard 595a#30109 Brown Orange
- C. DRAPERY: Coral; Color King; Windance - Heather/Red
- D. UPHOLSTERY:
1. DINING CHAIRS:
 - a. Davis; Gunsmith; Grade 45; Vinyl; GS-7 Russett
 - b. Davis; Rolf Solid; Grade 60; 100% Nylon; R-10
 - c. Davis; Hobnail; Grade 60; 100% Nylon; HB-304 Rust
 - d. Virco; Spirit of 76; Grade 3; Vinyl; Chestnut
 - e. Virco; Royal Nylon; Grade 5; 100% Nylon, Ginger
 - f. Virco; Spirit of 76; Grade 3; Vinyl; Burnt Orange
 2. LOUNGE CHAIRS: SAME UPHOLSTERY AS DINING CHAIRS a,b & c.
 3. LOVESEAT
 - a. Madison; Spirit of 76; Grade 5; Vinyl; U.S. 65 British Tan 4984
 - b. Madison; Spirit of 76; Grade 5; Vinyl; U.S. 75 Chestnut 4986
 - c. Madison; Erle; Grade 4; 100% Nylon; 4587 Char. Brown
 - d. Hiebert; Grade 1; 100% Nylon 1F/524 Rust/Black
 - e. Hiebert; Vinyl; v 20/2 Saddle
 - f. Hiebert; Grade 1; 100% Nylon; 1F/503 Rust
- E. WOOD FINISHES:
1. Davis; 800 Light Oak
 2. Madison; Natural Oak
 3. Hiebert; Clear Oak
- F. PLASTIC LAMINATES
1. DINING TABLES: Falcon; Formica; 346, Natural Oak
 2. OCCASIONAL TABLES: Hiebert; Russett Leather

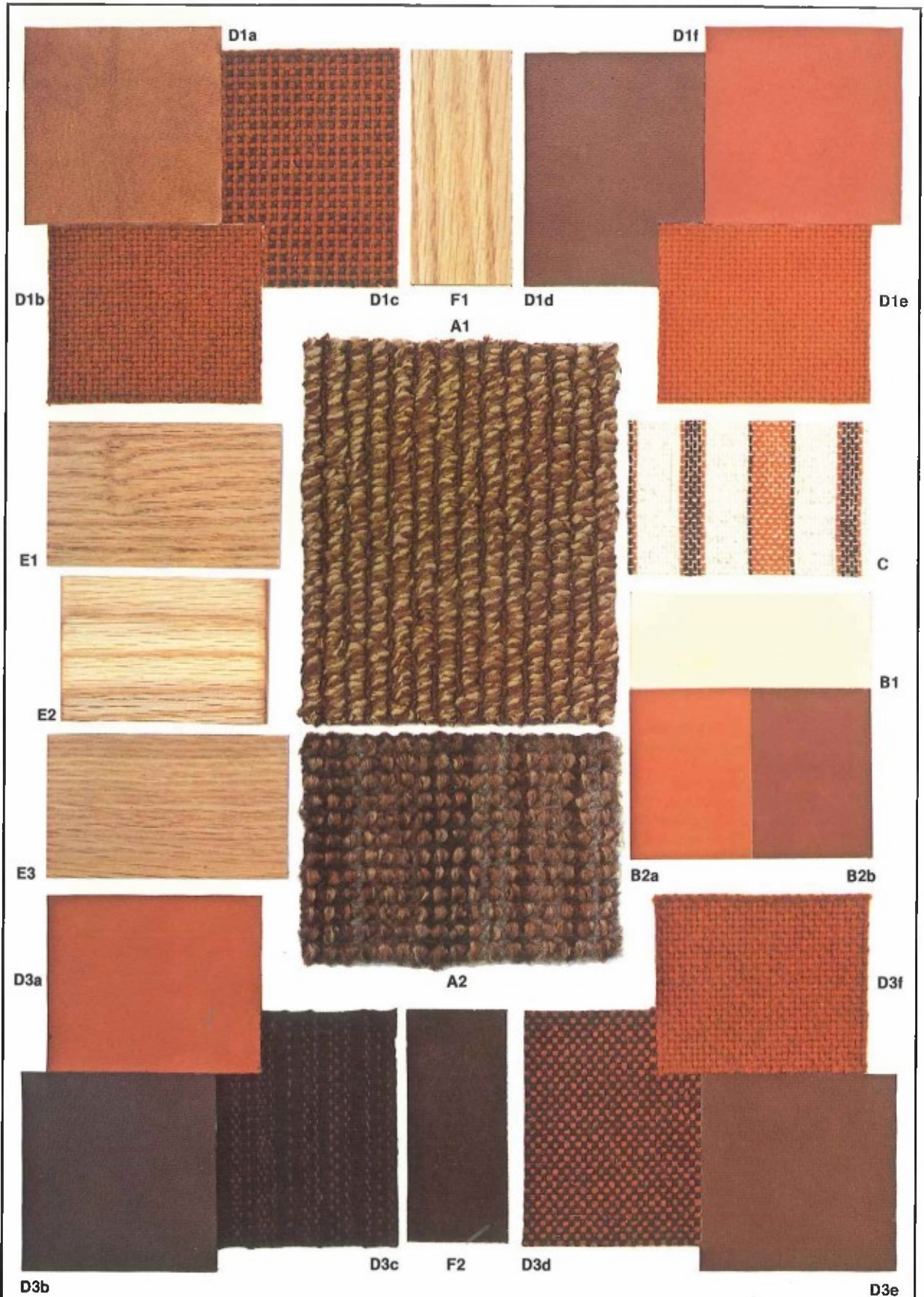

FABRIC & MATERIALS: BROWN/ORANGE SCHEME

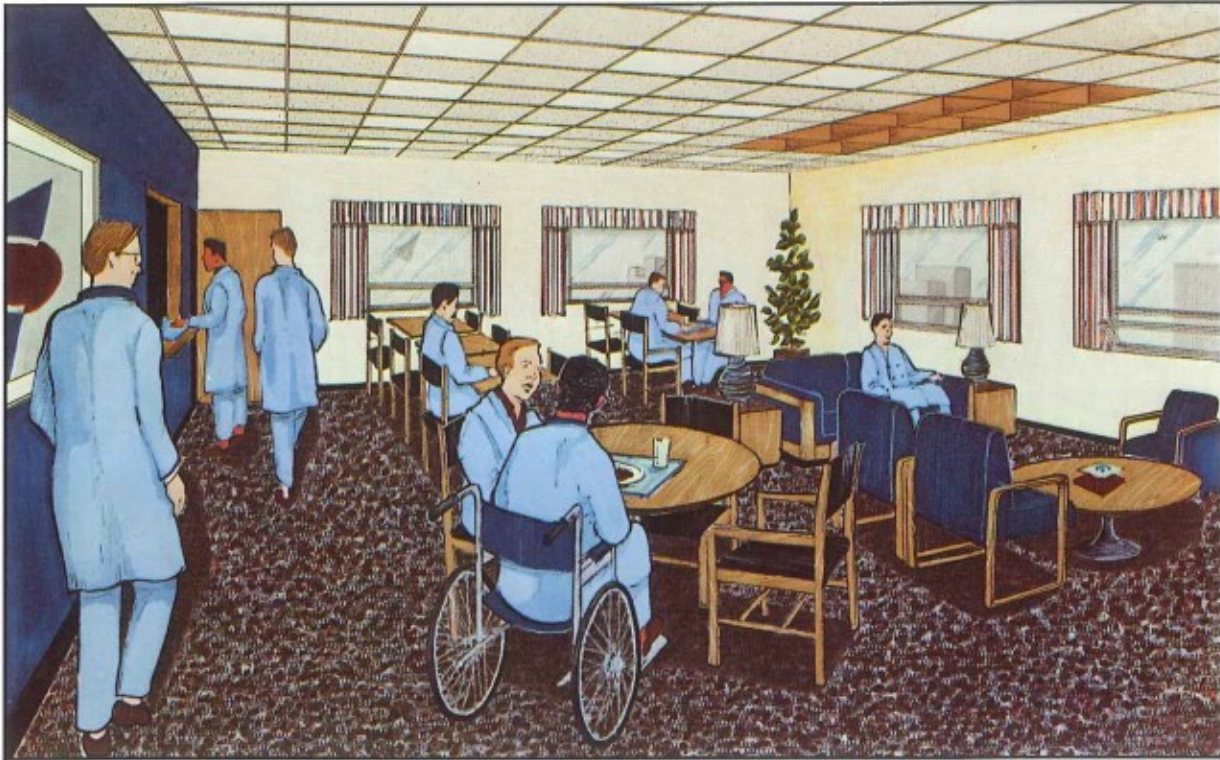

CORNER ROOM, ALTERNATIVE A: BLUE SCHEME

COLOR SCHEDULE: BLUE SCHEME

- A. CARPET:
 - 1. Milliken: 1979 Office Park; 6 Charcoal
 - 2. Bigelow: Regents Row; 3L43-51940; Bark Tweed
- B. WALL COLORS:
 - 1. PRIMARY WALL COLOR: Federal Standard 595a#33690 Off White
 - 2. ACCENT WALL COLORS:
 - a. Federal Standard 595a#35190 Light Blue
 - b. Federal Standard 595a#25102 Dark Blue
- C. DRAPERY: Coral; Color King; Tone Poem-Red/White/Blue
- D. UPHOLSTERY:
 - 1. DINING CHAIRS:
 - a. Davis; Gunsmith; Grade 45; Vinyl; GS-8 Black
 - b. Davis; Rolf Solid; Grade 60; 100% Nylon; R-23
 - c. Davis; Rold Solid, Grade 60; 100% Nylon; R-16
 - d. Virco; Royal Nylon; Grade 5; 100% Nylon; Black
 - e. Virco; Spirit of 76; Grade 3; Vinyl; Black
 - f. Virco; Spirit of 76; Grade 3; Vinyl; Regimental Blue
 - 2. LOUNGE CHAIRS: SAME UPHOLSTERY AS DINING CHAIRS a,b & c
 - 3. LOVESEAT
 - a. Madison; Erle; Grade 4; 100% Nylon; 4560 Blue
 - b. Madison; Splirt of 76; Grade 5; Vinyl; U.S. 45 Reg. Blue 4966
 - c. Madison; Erle; Grade 4; 100% Nylon; 4587 Char. Brown
 - d. Hiebert; Grade 1; 100% Nylon; 1F/623 Black
 - e. Hiebert; Vinyls; v1/2 Black and v3/2 Tahoe
 - f. Hiebert; Grade 1; 100% Nylon; 1F/593 Blue
- E. WOOD FINISHES:
 - 1. Davls; 800 Light Oak
 - 2. Madison; Natural Oak
 - 3. Hiebert; Clear Oak
- F. PLASTIC LAMINATES
 - 1. DINING TABLES: Falcon; Formica; 346, Natural Oak
 - 2. OCCASIONAL TABLES: Hiebert; Russett Leather

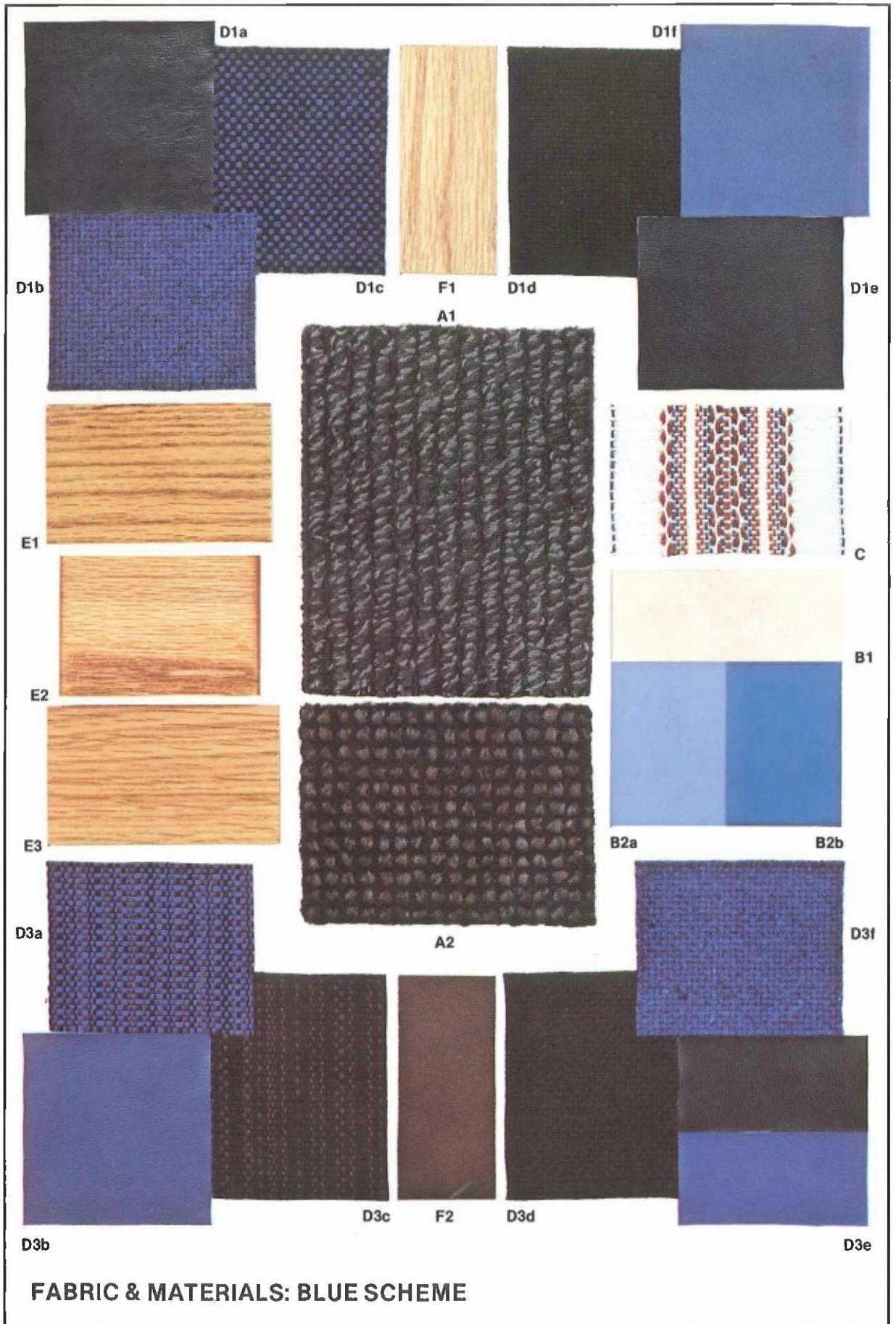

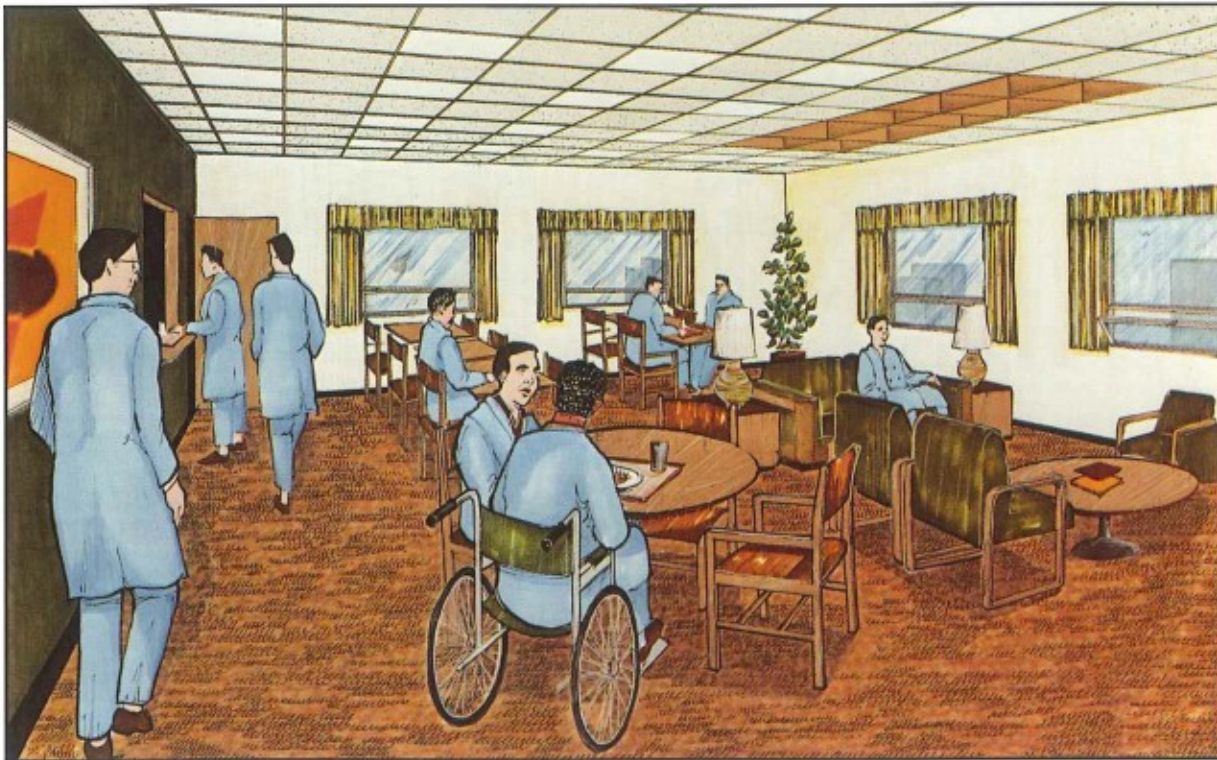

CORNER ROOM, ALTERNATIVE A: GREEN SCHEME

COLOR SCHEDULE: GREEN SCHEME

- A. CARPET:
 - 1. Milliken; 1979 Office Park; 5 Espresso Brown
 - 2. Bigelow; Regents Row; 3L43-52370; Berber Brown
- B. WALL COLORS:
 - 1. PRIMARY WALL COLOR: Federal Standard 595a#33717 Off White
 - 2. ACCENT WALL COLORS:
 - a. Federal Standard 595a#34097 Green
 - b. Federal Standard 595a#34096 Dark Green
- C. DRAPERY: Coral; Color King; Sundance - Brown/Natural
- D. UPHOLSTERY:
 - 1. DINING CHAIRS:
 - a. Davis; Gunsmith; Grade 45; Vinyl; GS-1 Saddle
 - b. Davis; Hobnail; Grade 60; 100% Nylon; HB-307 Olive
 - c. Davis; Roif Solid; Grade 60; 100% Nylon; R-14
 - d. Virco; Royal Nylon; Grade 5; 100% Nylon, Chestnut
 - e. Virco; Spirit of 76; Grade 3; Vinyl; Moss.
 - f. Virco; Spirit of 76; Grade 3; Vinyl; Chestnut
 - 2. LOUNGE CHAIRS: SAME UPHOLSTERY AS DINING CHAIRS a,b & c
 - 3. LOVESEAT
 - a. Madison; Erie; Grade 4; 100% Nylon; 4541 Gold
 - b. Madison; Spirit of 76; Grade 5; Vinyl; U.S. 75 Chestnut 4986
 - c. Madison; Erie; Grade 4; 100% Nylon; 4553 Avocado
 - d. Hiebert; Grade 1; 100% Nylon; 1F/453 Brown
 - e. Hiebert; Vinyl; v21/2 Brown
 - f. Hiebert; Grade 1; 100% Nylon; 1F/553 Green
- E. WOOD FINISHES:
 - 1. Davis; 800 Light Oak
 - 2. Madison; Natural Oak
 - 3. Hiebert; Clear Oak
- F. PLASTIC LAMINATES
 - 1. DINING TABLES: Falcon; Formica; 346 Natural Oak
 - 2. OCCASIONAL TABLES: Hiebert; Russett Leather

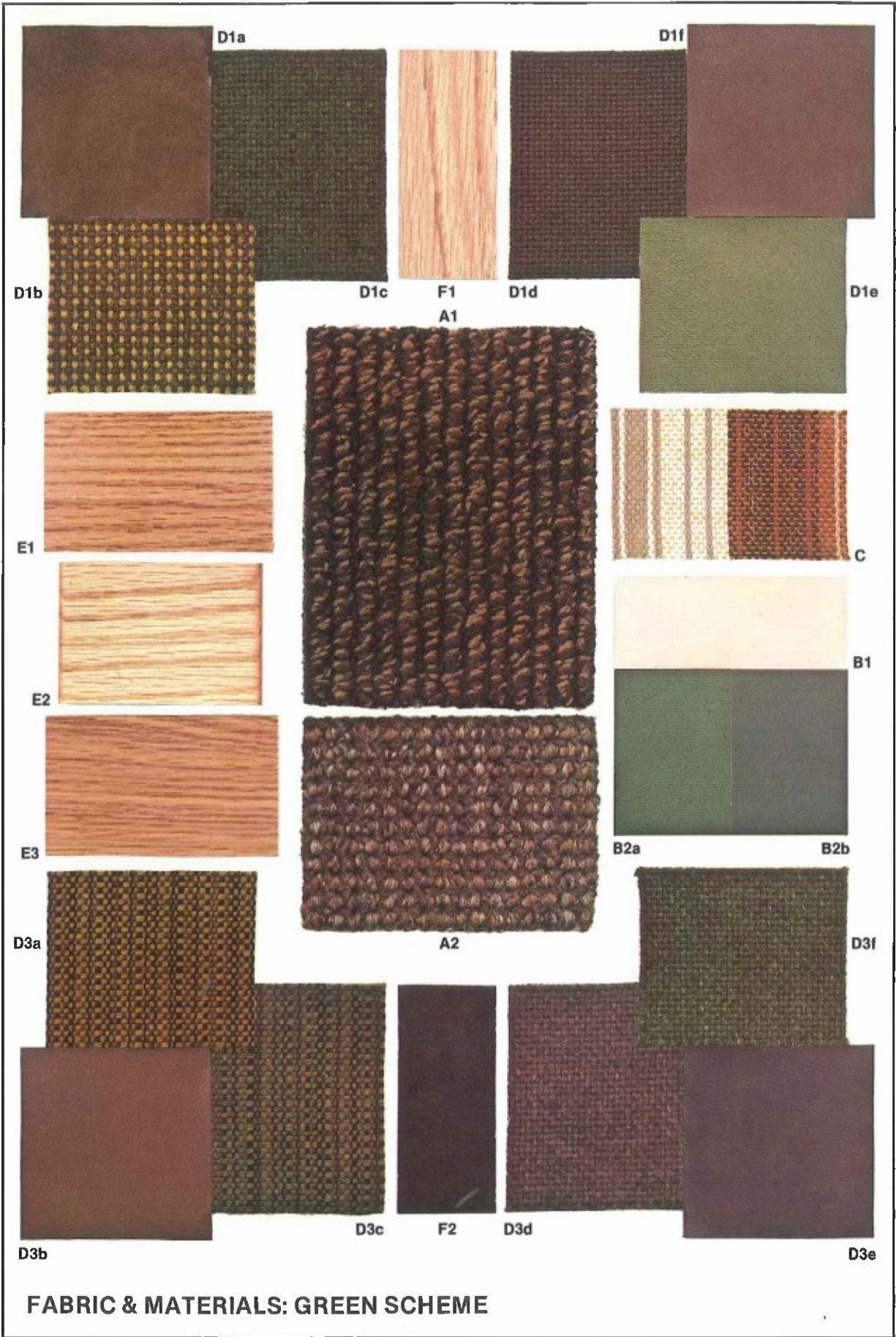

FABRIC & MATERIALS: GREEN SCHEME

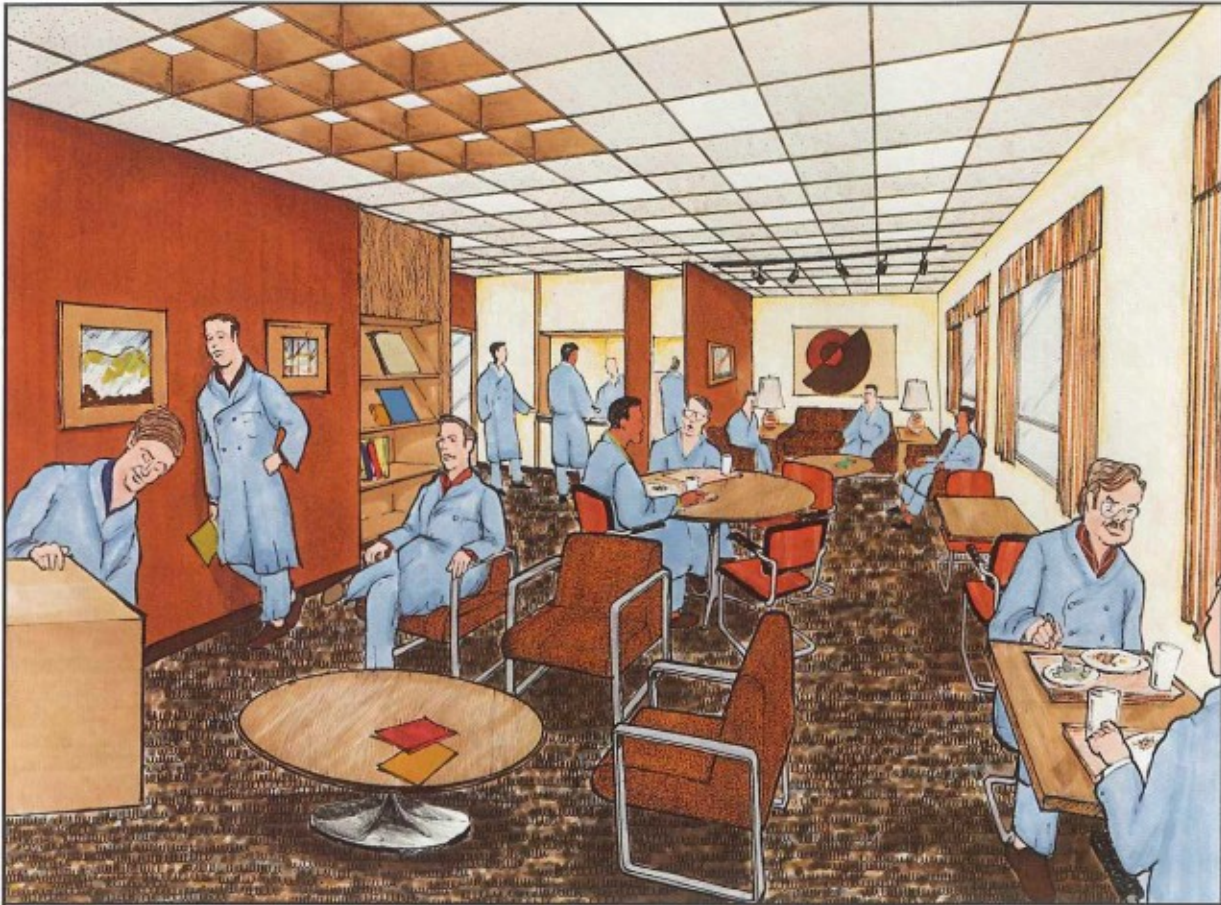

INTERIOR ROOM, ALTERNATIVE A: BROWN/ORANGE SCHEME

COLOR SCHEDULE: BROWN/ORANGE SCHEME

- A. CARPET:**
1. Milliken: 1979 Office Park; 3 Natural Brown
 2. Bigelow: Regents Stripe; 2J11-52819; Spice Brown Stripe
- B. WALL COLORS:**
1. PRIMARY WALL COLOR: Federal Standard 595a#27778 Off White
 2. ACCENT WALL COLORS:
 - a. Federal Standard 595a#32169 Rust
 - b. Federal Standard 595a#30109 Brown Orange
- C. DRAPERY:** Coral; Color King; Windance - Heather/Red
- D. UPHOLSTERY:**
1. DINING CHAIRS:
 - a. Davis; Gunsmith; Grade 45; Vinyl; GS-7 Russett
 - b. Davis; Rolf Solid; Grade 60; 100% Nylon; R-10
 - c. Davis; Hobnall; Grade 60; 100% Nylon; HB-304 Rust
 - d. Virco; Spirit of 76; Grade 3; Vinyl; Chestnut
 - e. Virco; Royal Nylon; Grade 5; 100% Nylon, Ginger
 - f. Virco; Spirit of 76; Grade 3; Vinyl; Burnt Orange
 2. LOUNGE CHAIRS: SAME UPHOLSTERY AS DINING CHAIRS a,b & c.
 3. LOVESEAT
 - a. Madison; Spirit of 76; Grade 5; Vinyl; U.S. 65 British Tan 4984
 - b. Madison; Spirit of 76; Grade 5; Vinyl; U.S. 75 Chestnut 4986
 - c. Madison; Erie; Grade 4; 100% Nylon; 4587 Char. Brown
 - d. Hiebert; Grade 1; 100% Nylon; 1F/524 Rust/Black
 - e. Hiebert; Vinyl; v20/2 Saddle
 - f. Hiebert; Grade 1; 100% Nylon; 1F/503 Rust
- E. WOOD FINISHES:**
1. Davis; 800 Light Oak
 2. Madison; Natural Oak
 3. Hiebert; Clear Oak
- F. PLASTIC LAMINATES**
1. DINING TABLES: Falcon; Formica; 346, Natural Oak
 2. OCCASIONAL TABLES: Hiebert; Russett Leather

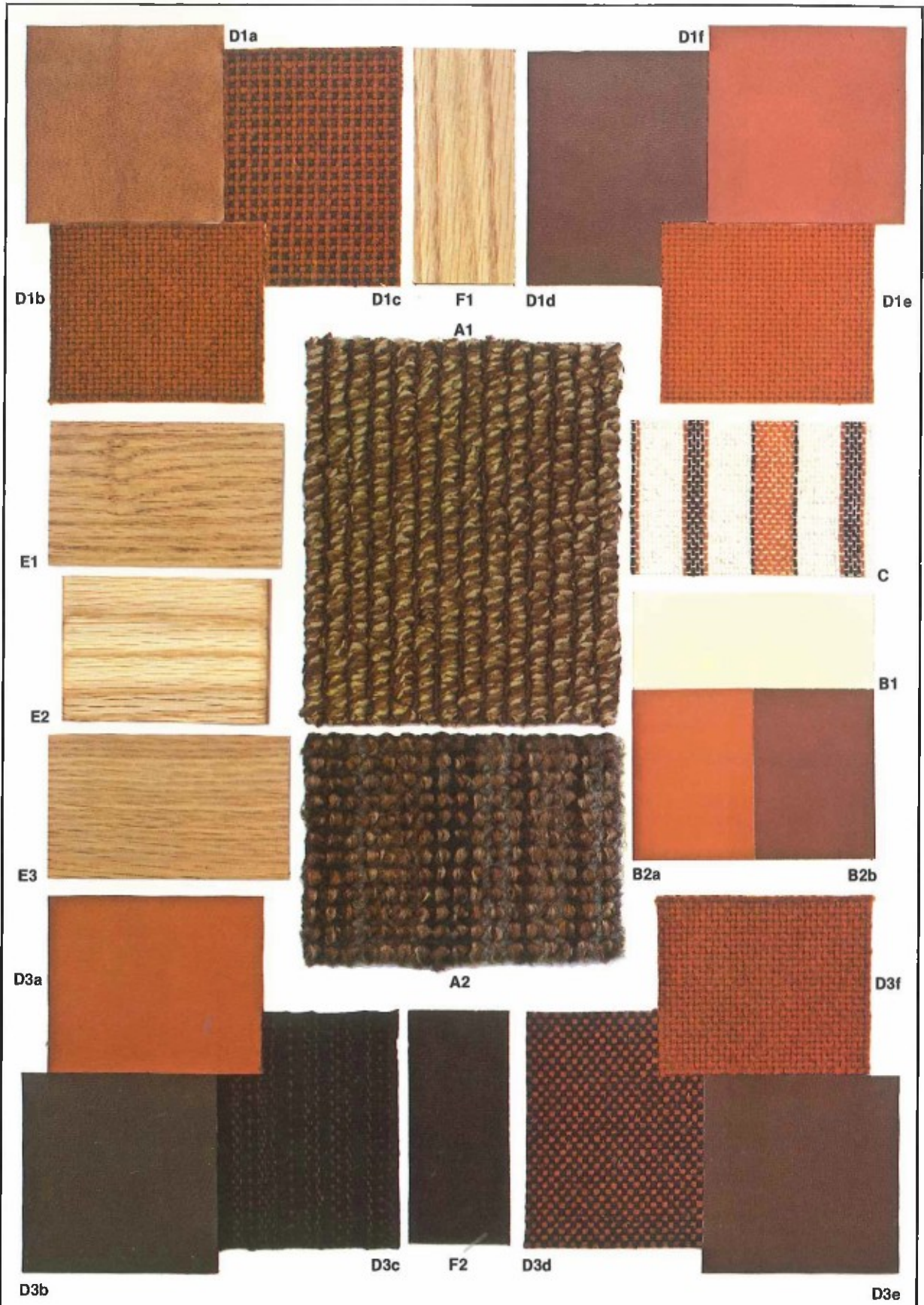

FABRIC & MATERIALS: BROWN/ORANGE SCHEME

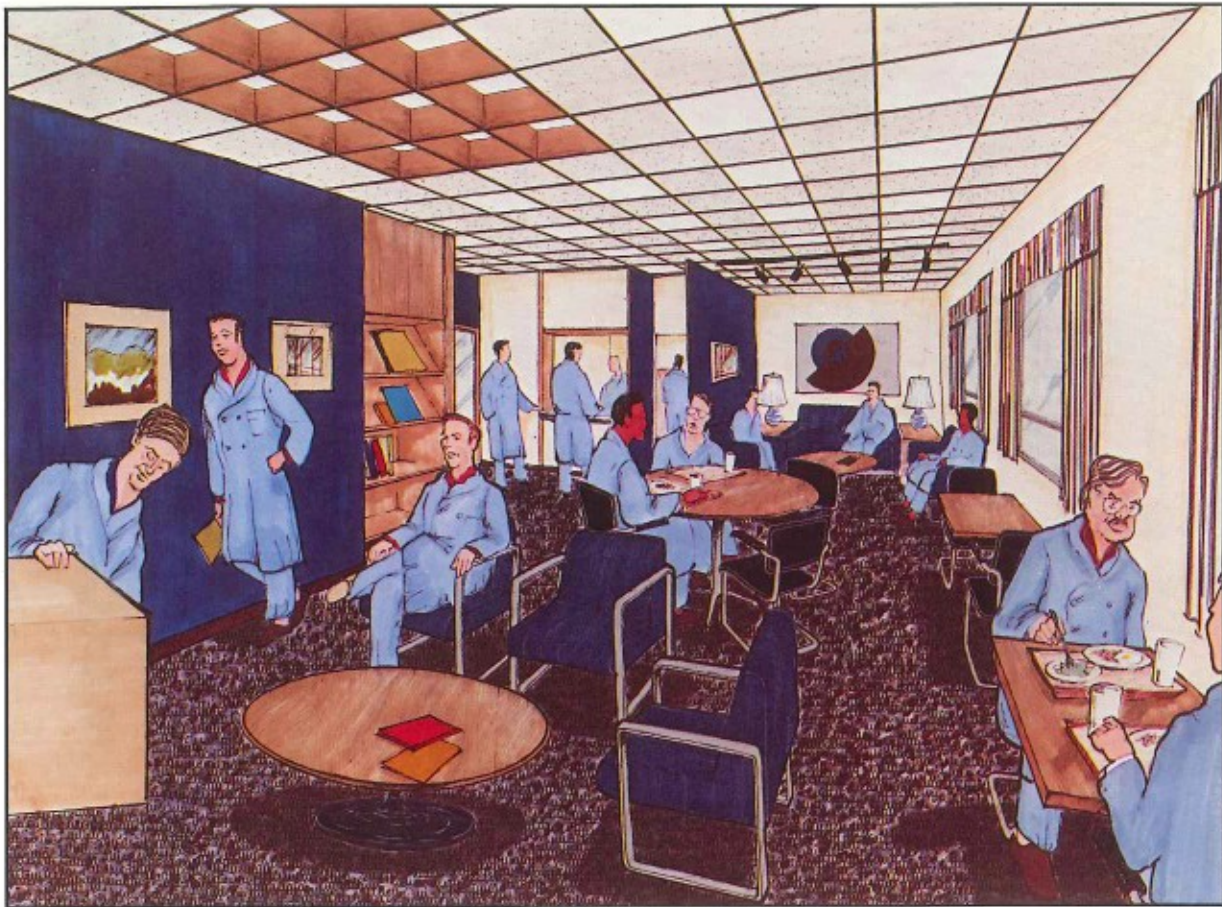

INTERIOR ROOM, ALTERNATIVE A: BLUE SCHEME

COLOR SCHEDULE: BLUE SCHEME

- A. CARPET:
 - 1. Milliken: 1979 Office Park; 6 Charcoal
 - 2. Bigelow: Regents Row; 3L43-51940; Bark Tweed
- B. WALL COLORS:
 - 1. PRIMARY WALL COLOR: Federal Standard 595a#33690 Off White
 - 2. ACCENT WALL COLORS:
 - a. Federal Standard 595a#35190 Light Blue
 - b. Federal Standard 595a#25102 Dark Blue
- C. DRAPERY: Coral; Color King; Tone Poem-Red/White/Blue
- D. UPHOLSTERY:
 - 1. DINING CHAIRS:
 - a. Davis; Gunsmith; Grade 45; Vinyl; GS-8 Black
 - b. Davis; Rolf Solid; Grade 60; 100% Nylon; R-23
 - c. Davis; Rold Solid, Grade 60; 100% Nylon; R-16
 - d. Virco; Royal Nylon; Grade 5; 100% Nylon; Black
 - e. Virco; Spirit of 76; Grade 3; Vinyl; Black
 - f. Virco; Spirit of 76; Grade 3; Vinyl; Regimental Blue
 - 2. LOUNGE CHAIRS: SAME UPHOLSTERY AS DINING CHAIRS a,b & c
 - 3. LOVESEAT
 - a. Madison; Erie; Grade 4; 100% Nylon; 4560 Blue
 - b. Madison; Spirit of 76; Grade 5; Vinyl; U.S. 45 Reg. Blue 4966
 - c. Madison; Erie; Grade 4; 100% Nylon; 4587 Char. Brown
 - d. Hiebert; Grade 1; 100% Nylon; 1F/623
 - e. Hiebert; Vinyls; v1/2 Black and v3/2 Tahoe
 - f. Hiebert; Grade 1; 100% Nylon; 1F/593 Blue
- E. WOOD FINISHES:
 - 1. Davis; 800 Light Oak
 - 2. Madison; Natural Oak
 - 3. Hiebert; Clear Oak
- F. PLASTIC LAMINATES
 - 1. DINING TABLES: Falcon; Formica; 346, Natural Oak
 - 2. OCCASIONAL TABLES: Hiebert; Russett Leather

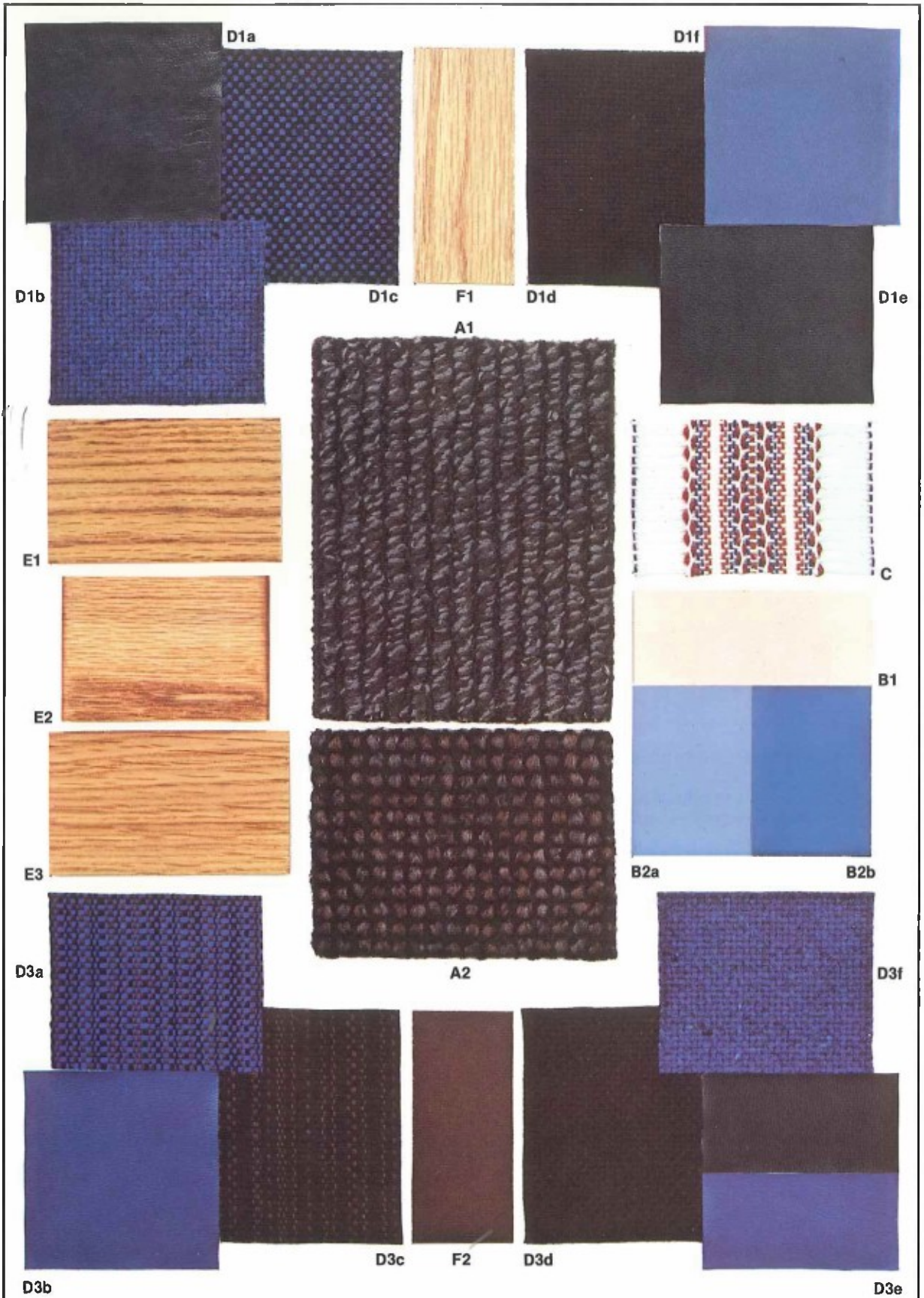

FABRIC & MATERIALS: BLUE SCHEME



INTERIOR ROOM, ALTERNATIVE A: GREEN SCHEME

COLOR SCHEDULE: GREEN SCHEME

- A. CARPET:
 - 1. Milliken: 1979 Office Park; 5 Espresso Brown
 - 2. Bigelow: Regents Row; 3L43-52370; Berber Brown
- B. WALL COLORS:
 - 1. PRIMARY WALL COLOR: Federal Standard 595a#33717 Off White
 - 2. ACCENT WALL COLORS:
 - a. Federal Standard 595a#34097 Green
 - b. Federal Standard 595a#34096 Dark Green
- C. DRAPERY: Coral; Color King; Sundance - Brown/Natural
- D. UPHOLSTERY:
 - 1. DINING CHAIRS:
 - a. Davis; Gunsmith; Grade 45; Vinyl; GS-1 Saddle
 - b. Davis; Hobnail; Grade 60; 100% Nylon; HB-307 Olive
 - c. Davis; Rolf Solid; Grade 60; 100% Nylon; R-14
 - d. Virco; Royal Nylon; Grade 5; 100% Nylon, Chestnut
 - e. Virco; Spirit of 76; Grade 3; Vinyl; Moss
 - f. Virco; Spirit of 76; Grade 3; Vinyl; Chestnut
 - 2. LOUNGE CHAIRS: SAME UPHOLSTERY AS DINING CHAIRS a, b & c
 - 3. LOVESEAT
 - a. Madison; Erie; Grade 4; 100% Nylon; 4541 Gold
 - b. Madison; Spirit of 76; Grade 5; Vinyl; US 75 Chestnut 4986
 - c. Madison; Erie; Grade 4; 100% Nylon; 4553 Avocado
 - d. Hiebert; Grade 1; 100% Nylon; 1F/453 Brown
 - e. Hiebert; Vinyl; v21/2 Brown
 - f. Hiebert; Grade 1; 100% Nylon; 1F/553 Green
- E. WOOD FINISHES:
 - 1. Davis; 800 Light Oak
 - 2. Madison; Natural Oak
 - 3. Hiebert; Clear Oak
- F. PLASTIC LAMINATES
 - 1. DINING TABLES: Falcon; Formica; 346 Natural Oak
 - 2. OCCASIONAL TABLES: Hiebert; Russett Leather

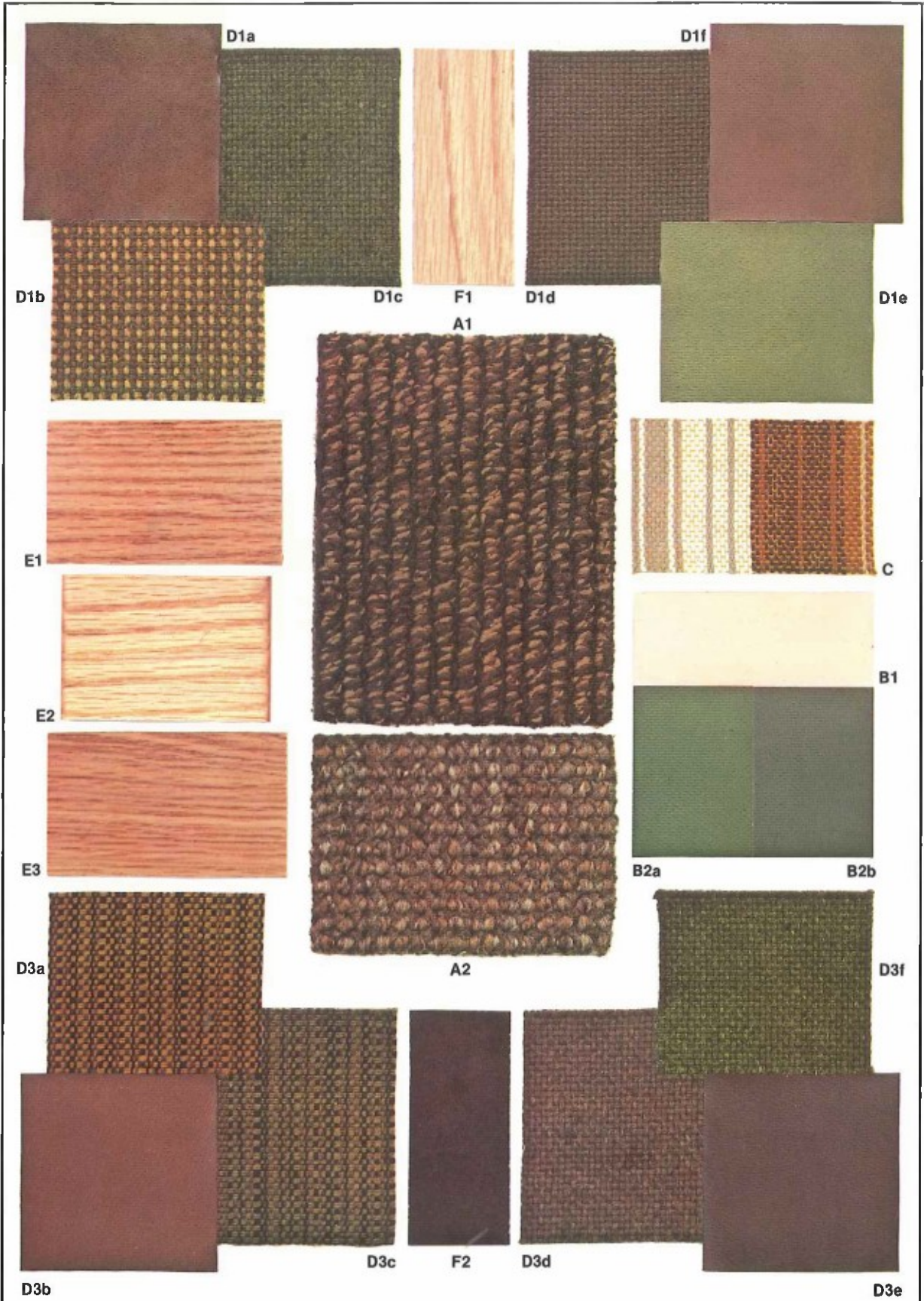

FABRIC & MATERIALS: GREEN SCHEME



A1 Matte White

Matte Black

Satin Aluminum



A2 Matte White

Teakwood (Vinyl)

Matte Black



B. Teakwood Grained Vinyl



C. Gold Brown

Matte Black

FIXTURES & ACCESSORIES

FIXTURE/ACCESSORY SCHEDULE

A. TRACK LIGHTING: LIGHTOLIER

1. Limelite Multi-Groove
 - a. 7101 Matte White
 - b. 7111 Matte White
 - c. 7100 Matte Black
 - d. 7110 Matte Black
 - e. 7104 Satin Aluminum
 - f. 7114 Satin Aluminum
2. Soft Square
 - a. 6304 Matte White
 - b. 6305 Matte White
 - c. 6307 Teakwood (Vinyl)
 - d. 6308 Teakwood (Vinyl)
 - e. 6301 Matte Black
 - f. 6302 Matte Black

B.

COFFER LIGHTING: LIGHTOLIER

1. 220 Coffer: CD3-225 Teakwood Grained Vinyl
CD3-1212 White Acrylic Diffuser

C. LAMPS: MARSHALL STUDIOS

1. Lamp 101-23-D-36 Green; FG Natural Gauze Shade
2. Lamp 101-23-D-36 Dark Blue; FG, Natural Gauze Shade
3. Lamp 101-23-D-36 Gold Brown; FG, Natural Gauze Shade
4. Lamp 101-45 Matte Black; 621 White Linen Shade

a. **Traffic Flow.** Traffic begins at the identification graphic at the entrance. Trays are available from the galley bussing window as the patient enters the room. From that location the patient with his/her tray has an unhampered view of the dining tables to choose a place to sit. When the meal is finished, trays can be returned at the galley window.

b. **Buddy System.** Non-ambulatory patients in wheelchairs and semi-ambulatory patients on crutches or walkers can use the dayroom dining area. To facilitate the use by all patients a buddy system is recommended. Rather than have nursing staff wheel patients to their tables and carry their food trays, other patients can perform these duties. These "buddies" can be roommates or other willing patients who will themselves be going for their meals. By freeing the nursing staff of this responsibility, more time can be spent by the medical staff with bed patients who often require more assistance.

c. **Food Service.** Since patient tray delivery systems can provide totally assembled trays, the bussing window may not be necessary, or desired. As mentioned earlier, any deletion of service windows or walls result in an increase of usable floor space that can then be dedicated to seating capacity.

The galley can be staffed for the delivery of food trays based on an average service time of one minute per food tray which requires food service staff in the galley for approximately 20 minutes per meal. This staff member pours drinks and hands the trays to the patients at the service/bussing window.

d. **Restrooms.** For convenience and comfort, DoD instructions prescribe restrooms in kitchen areas for both men and women staff members. While the galley area may not be strictly classified as a kitchen area, it will be staffed by food service personnel. Patient rooms do have toilet facilities and lavatories, but these were not intended for public usage. In fact, their private use by the room occupant(s) is necessary for infection control. Thus, for the convenience of patients, guests, and staff, and dayroom dining area users, and to meet DoD requirements, public restrooms are provided.

e. **Telephone.** A public telephone booth is provided in the immediate dayroom dining areas, since room telephones are not consistently placed in all Army hospitals. In this design, the telephone booth is sound insulated and, while convenient to the dayroom dining area, is located outside of the space itself to allow privacy in telephone conversations. Prevailing management policies and telephone company advice will determine the inclusion of the telephone booth.

Special Design Considerations

During the recovery process, the physically impaired patient confined to a wheelchair must be able to move about as freely and with as little assistance as possible. Since the proper care of wheelchair patients is important, the designs presented here have followed the guidelines suggested by the American Standards Association in their ASA Standard A117.1-1961, *Making Buildings and Facilities Accessible to and Usable by the Physically Handicapped*.

In these solutions, the handicapped patient has been taken into consideration from the outset, and not as an afterthought. For this reason, these flexible designs do not have to be retrofitted for the physically impaired, but can accommodate any type of patient. Equally important, these special design considerations do not represent a double standard-if the physically handicapped can use the space, then anyone can.

Wheelchair Dimensions (Figure 1-3) – The wheelchair is the basic vehicle for non-ambulatory patients and its dimensions establish the access and design requirements. Crutch-, or brace-supported, semi-ambulatory patients can maneuver within the space dimensions requirements demanded by wheelchairs. The following limits are those used by wheelchair manufacturers and were used in the design of the dayroom dining areas:

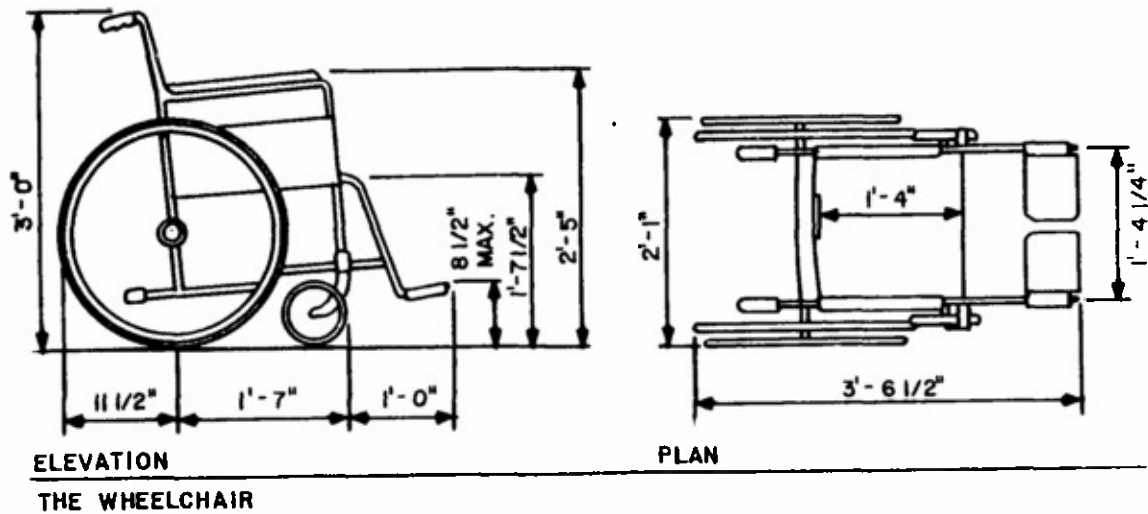

Figure 1-3. Wheelchair Dimensions

- a. Length: 42 inches
- b. Width: 25 inches
- c. Height of seat from floor: 19-1/2 inches
- d. Height of armrest from floor: 29 inches
- e. Height of pusher handles from floor: 36 inches

a. Seating. To allow wheelchairs to be able to use the dining table, 30- x 36-inch rectangular tables are specified, as are 48-inch round tables. For comfortable access the following dimensions shown in Figure 1-4 were used:

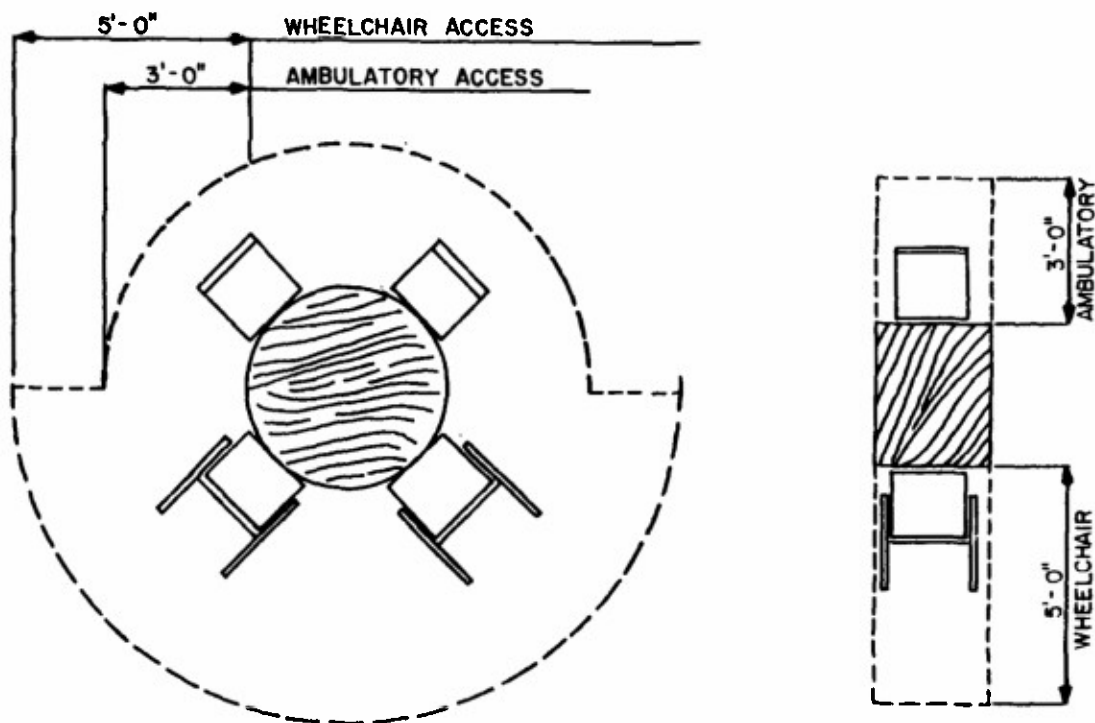
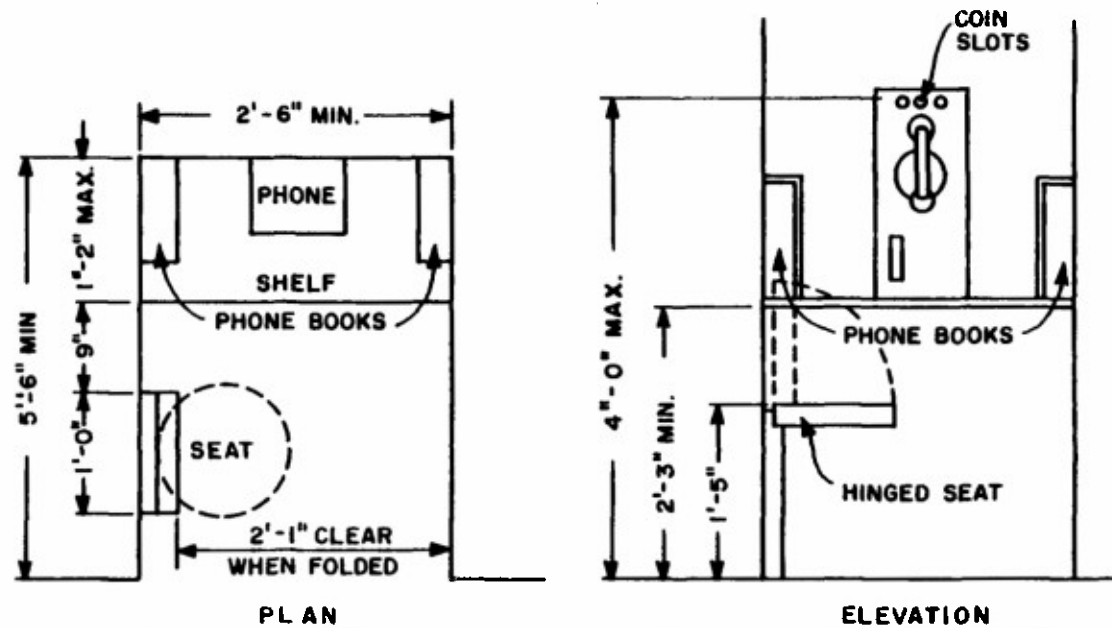

Figure 1-4. Table Design

b. Restrooms. Restrooms have been provided for patient comfort and convenience and have been designed according to hospital standards which by law must accommodate the physically handicapped. While these special design considerations are important, restrooms are carefully detailed elsewhere⁵⁶ and are not repeated in this report.

c. Telephone. A public telephone has been made a part of the dayroom dining area concept. This telephone is somewhat different from the conventional public booth in that it is not usable by most physically disabled persons. The major considerations are that a wheelchair can (1) reach the telephone, and (2) the telephone is placed so that the dial and handset can be reached from a wheelchair. The following illustration (Figure 1-5) can be used as design guidance.



PUBLIC TELEPHONES

Figure 1-5. Telephone Design

⁵⁶ DeChiara, J. and Cellender, J. H., Time-Save Standards for Building Types, New York: McGraw Hill, 1973.