

AD-A062 011

LIFE SYSTEMS INC CLEVELAND OHIO

F/G 7/4

EVALUATION OF A BREADBOARD ELECTROCHEMICAL TOC/COD ANALYZER. (U)

OCT 78 R J DAVENPORT, T A BERGER, R A WYNVEEN DAMD17-76-C-6077

UNCLASSIFIED

LSI-ER-310-4-2

NL

1 OF 1
AD
A062011



END
DATE
FILMED
3--79
DDC

LEVEL II

11
B.S.

LSI ER-310-4-2

EVALUATION OF A BREADBOARD ELECTROCHEMICAL TOC/COD ANALYZER (U)

ANNUAL REPORT

by

R.J. Davenport, T.A. Berger
and R.A. Wynveen

October, 1978

DDC
RECEIVED
DEC 11 1978
F

Project Officer: William J. Cooper
Environmental Protection Research Division
US Army Medical Bioengineering
Research and Development Laboratory
Ft., Detrick, Frederick, MD 21701

Supported by

**US ARMY MEDICAL RESEARCH
AND DEVELOPMENT COMMAND**
Ft. Detrick, Frederick, MD 21701

Contract No. DAMD17-76-C-6077

Life Systems, Inc.

Cleveland, OH 44122

78 12 04 195

Approved for Public Release; Distribution Unlimited

The findings in this report are not to be construed as an official Department
of the Army position unless so designated by other authorized documents

ADA062011

DDC FILE COPY

Disclaimer

The findings in this report are not to be construed as an official Department of the Army position, unless so designated by other authorized documents.

Disposition

Destroy this report when no longer needed. Do not return it to the originator.

UNCLASSIFIED

SECURITY CLASSIFICATION OF THIS PAGE (When Data Entered)

14

LSI-ER REPORT DOCUMENTATION PAGE

READ INSTRUCTIONS BEFORE COMPLETING FORM

1. REPORT NUMBER
LSI-310-4-2

2. GOVT ACCESSION NO.

3. RECIPIENT'S CATALOG NUMBER

6

4. TITLE (and Subtitle)
EVALUATION OF A BREADBOARD ELECTROCHEMICAL TOC/COD ANALYZER

9

5. TYPE OF REPORT & PERIOD COVERED
Annual Report, September 1, 1977 to October 31, 1978

10

7. AUTHOR(s)
R. J. Davenport, T. A. Berger and R. A. Wynveen

6. PERFORMING ORG. REPORT NUMBER
1 Sep 77 - 31 Oct 78

8. CONTRACT OR GRANT NUMBER(s)
DAMD17-76-C-6077

9. PERFORMING ORGANIZATION NAME AND ADDRESS
Life Systems, Inc.
24755 Highpoint Road
Cleveland, OH 44122

10. PROGRAM ELEMENT, PROJECT, TASK AREA & WORK UNIT NUMBERS
62720A
3E762720A83500078

11. CONTROLLING OFFICE NAME AND ADDRESS
U. S. Army Medical R & D Command
Ft. Detrick, Frederick, MD 21701

11

12. REPORT DATE
October, 1978

13. NUMBER OF PAGES
61

14. MONITORING AGENCY NAME & ADDRESS (if different from Controlling Office)
U. S. Army Medical Bioengineering Research Development Laboratory
Ft. Detrick, Frederick, MD 21707

12 63p.

15. SECURITY CLASS. (of this report)
UNCLASSIFIED

15a. DECLASSIFICATION/DOWNGRADING SCHEDULE
NA

16. DISTRIBUTION STATEMENT (of this Report)

Approved for Public Release; Distribution Unlimited

17. DISTRIBUTION STATEMENT (of the abstract entered in Block 20, if different from Report)

18. SUPPLEMENTARY NOTES

19. KEY WORDS (Continue on reverse side if necessary and identify by block number)

Breadboard, Carbon Dioxide, Chemical Oxygen Demand, Dissolved Organic Carbon, Electrochemical TOC/COD Analyzer, Electrode, Monitor, Organic Solute, Particulate Organic Carbon, Persulfate, Sensors, Total Organic Carbon

20. ABSTRACT (Continue on reverse side if necessary and identify by block number)

The Breadboard Electrochemical TOC/COD Analyzer has been assembled, tested and evaluated. The Analyzer operates on the basis of UV-catalyzed oxidation of organic solutes by persulfate. The Breadboard Analyzer has demonstrated for the first time that this technique can be used to measure COD concentrations and that COD measurements can be made simultaneously with TOC measure-

8 12 04 195 continued-

390850

20. continued -

ments using only one analyzer. Operating conditions have been optimized and synthetic and real samples have been analyzed. The results obtained with the Breadboard Analyzer agree closely with the results of standard methods. Particulates do not interfere in the analyses and samples ranging from tap water to raw sewage have been successfully analyzed.

The Breadboard Analyzer has been designed using concepts and analysis techniques that lend themselves to accurate, automated operation in the field and in industrial process monitoring and control applications. Future developments are anticipated to lead to automated, unattended operation for at least 30 days. Results, conclusions and recommendations are included.

Handwritten form with fields and checkboxes:

ADMISSION for	White Section <input checked="" type="checkbox"/>	
	Bluff Section <input type="checkbox"/>	
THIS		
DATE		
BY		
DISTRIBUTION/AVAILABILITY CODES		
	SPECIAL	

Handwritten initials "M" are present in the bottom left corner of the form.

ER-310-4-2

EVALUATION OF A BREADBOARD
ELECTROCHEMICAL TOC/COD ANALYZER (U)

ANNUAL REPORT

by

R. J. Davenport, T. A. Berger
and R. A. Wynveen

October, 1978

Distribution of this report is provided in the interest of
information exchange. Responsibility for the contents resides
in the authors or organization that prepared it.

Prepared Under Contract DAMD17-76-C-6077

by

LIFE SYSTEMS, INC.
Cleveland, OH 44122

for

U. S. Army Medical Bioengineering
Research and Development Laboratory
Ft. Detrick, Frederick, MD 21701

EXECUTIVE SUMMARY

The Electrochemical Total Organic Carbon and Chemical Oxygen Demand Analyzers were conceptually designed for a feasibility evaluation under Contract DAMD17-75-C-5070. The analyzer design goals include the capability for simple, automated monitoring of organic solute concentrations throughout the range of 0.1 to 10 ppm total organic carbon and 0.5 to 30 ppm chemical oxygen demand. They are designed for on-line field applications, but the designs are also compatible with industrial process monitoring and control applications. The designs contain the features of continuous operation and in situ generation of the required reagent. Electrochemical generation of reagents avoids the necessity of supplying reagents to the analyzers in the field and minimizes their logistic demands. It also reduces the cost of operating the analyzers by reducing labor required for reagent preparation and storage. Because of the simplicity of the analyzer designs, the end item analyzers are anticipated to be lower priced than commercially available, process-oriented analyzers.

A detailed evaluation of the analyzers indicated that many similarities exist between them. It was concluded that they could be combined into a single analyzer capable of simultaneously monitoring total organic carbon and chemical oxygen demand. Both measurements are based on the ultraviolet-catalyzed oxidation of organic solutes with persulfate, a strong chemical oxidizing agent. Total organic carbon is determined by measuring the amount of carbon dioxide produced by the organic oxidation, while chemical oxygen demand is determined by measuring the amount of persulfate consumed during the oxidation.

During a previous phase of this program (Contract DAMD17-76-C-6077), the key components of the combined Electrochemical Total Organic Carbon/Chemical Oxygen Demand Analyzer were identified, tested and evaluated. These components are the persulfate generation cell for in situ generation of persulfate, and the carbon dioxide and persulfate sensors used to measure total organic carbon and chemical oxygen demand, respectively. Results of this effort demonstrate that the required analytical performance can be obtained using the sensors and operation of the analyzer for at least thirty days without need for expendables is possible using in situ persulfate generation with an electrolyte recycle loop.

During the current phase of the program the Breadboard Electrochemical Total Organic Carbon/Chemical Oxygen Demand Analyzer was designed, fabricated, tested and evaluated. The objectives of this effort were to (1) verify that chemical oxygen demand measurements can be made by oxidizing organics using persulfate in place of potassium dichromate which is used in the standard method, (2) identify the optimum conditions for oxidizing organic solutes in the analyzer, (3) investigate the effects of potential interferences upon the organic oxidation process, (4) investigate the possible effects of oxidation products on the sensors in the analyzer and (5) perform an initial comparison of data obtained with the analyzer and standard methods.

To achieve these objectives with maximum flexibility and minimum hardware development, the Breadboard Analyzer was assembled using the sensors evaluated during the Key Components Evaluation and an ultraviolet reactor which was previously developed as part of Life Systems' Continuous, Chemical Total Organic Carbon Analyzer.

Tests performed with the Breadboard Analyzer have demonstrated that total organic carbon and chemical oxygen demand measurements can be made simultaneously using the persulfate oxidation technique. Optimum conditions for measuring concentrations up to 10 ppm total organic carbon and 30 ppm chemical oxygen demand have been identified. Conditions for higher concentration ranges have also been investigated. The only significant interference discovered during the program is chloride, which is also an interference in the standard chemical oxygen demand method. As in the standard method, the effects of chloride ions can be overcome by adding mercuric sulfate to the electrolyte in the analyzer.

A comparison of data obtained with the Breadboard Analyzer and standard methods has shown close agreement for total organic carbon measurements, even for refractory compounds and solutions that contain particulates. Chemical oxygen demand values obtained with the Breadboard Analyzer are somewhat larger than those obtained by standard methods. This is concluded to be the result of a number of things. First, volatile organics are lost from the sample during the two hour reflux in the standard method, but not from the Breadboard Analyzer. Second, persulfate is a stronger oxidizing agent than dichromate and more completely oxidizes refractory organics, resulting in larger chemical oxygen demand values. For example, pyridine is quantitatively oxidized by persulfate but is only slightly oxidized by dichromate. Finally, oxidation of some refractory organics, such as acetic acid, in the Breadboard Analyzer results in larger chemical oxygen demand values because of differences between the oxidation mechanism of those solutes and other less refractory organics.

Future recommended activities include development of an Advanced Breadboard Analyzer that incorporates all components projected for use in the end item analyzer, with the possible exception of the electrolyte recycle loop which may be added later. The Advanced Breadboard can be used to fully demonstrate and test all functions of the analyzer. Also, using the Advanced Breadboard, data can be obtained in a cost-effective manner to evaluate the performance of the analyzer under conditions similar to those anticipated in field or process monitoring and control applications.

FOREWORD

The analytical and experimental work described herein was performed by Life Systems, Inc., under U. S. Army Contract DAMD17-76-C-6077 during the period September 1, 1977 to October 31, 1978. The program was directed by Dr. R. J. Davenport. The technical effort was completed by Dr. T. A. Berger, Dr. R. J. Davenport, Mr. L. E. Wolfe and Dr. R. A. Wynveen.

Mr. William J. Cooper was the Contract Officer's Technical Representative for the U. S. Army Medical Bioengineering Research and Development Laboratory, Ft. Detrick, Frederick, MD 21701. Mr. Gerald McKee and Mr. Larry Lobring represented the Environmental Monitoring and Support Laboratory, Environmental Protection Agency, Cincinnati, OH 45268. Dr. Deh Bin Chan and Mr. Richard Saam represented the Civil Engineering Laboratory at Port Hueneme, CA 93010. Cpt. Gary R. McNutt represented the Civil and Environmental Engineering Development Office, Tyndall Air Force Base, FL 32401. Mr. David L. Tanenbaum represented the Chemical Systems Laboratory, Aberdeen Proving Ground, MD 21010.

TABLE OF CONTENTS

	<u>PAGE</u>
EXECUTIVE SUMMARY	1
FOREWORD	2
LIST OF FIGURES	4
LIST OF TABLES	5
ACRONYMS	5
INTRODUCTION	6
Definitions	7
Conceptual Design of End Item Analyzer	8
Program Organization	14
BREADBOARD ELECTROCHEMICAL TOC/COD ANALYZER	17
Design Objectives	17
Analyzer Design	17
UV Reactors	19
TOC Sensor	19
COD Sensor	19
Analyzer Logic	24
Other Circuitry	24
TEST SUPPORT ACCESSORIES	24
TEST PROGRAM	27
Checkout Tests	27
Parametric Tests	28
Interference Tests	30
Particulate Interference Study	30
Inorganic Salt Interference Study	30
Sample Analysis	34
Synthetic Samples	34
Real Samples	44
CONCLUSIONS	51
RECOMMENDATIONS	54
REFERENCES	56

LIST OF FIGURES

<u>FIGURE</u>		<u>PAGE</u>
1	Schematic of End Item Electrochemical TOC/COD Analyzer	9
2	Inorganic Carbon Stripper Schematic	10
3	Continuous Chemical TOC Analyzer Schematic	11
4	LSI'S Chemical, Continuous TOC Analyzer	12
5	Breadboard Inorganic Carbon Stripper	13
6	Osmotic Still Schematic	15
7	Schematic of Breadboard Electrochemical TOC/COD Analyzer	18
8	Breadboard Electrochemical TOC/COD Analyzer	20
9	UV Reactors Schematic	21
10	TOC Sensor Schematic	22
11	COD Sensor Schematic	23
12	TOC Sensor Response	25
13	Response of COD Sensor	26
14	COD Response of Breadboard Analyzer With NH_4HSO_4 Electrolyte	29
15	TOC Response of Breadboard Analyzer to Individual Organic Solutes	36
16	TOC Response of Breadboard Analyzer	37
17	TOC Response of Breadboard Analyzer at Low Concentrations	38
18	TOC Response of Breadboard Analyzer at High Concentrations	39
19	COD Response of Breadboard Analyzer Before Calibration	42
20	COD Response of Breadboard Analyzer After Calibration	43

LIST OF TABLES

<u>TABLE</u>		<u>PAGE</u>
1	Preliminary Design Goals and Specifications of End Item Electrochemical TOC/COD Analyzer	16
2	Results of Inorganic Particulates Study	31
3	Results of Inorganic Salts Study	33
4	Demonstration of Effectiveness of Chloride Interference Elimination	35
5	Comparisons of Organic Oxidations With and Without Persulfate	41
6	Results of Particulate-Free Sample Analyses	45
7	Documented Methods of POC Analysis	47
8	Results of TOC Analyses of Particulate-Containing Samples . . .	49
9	Results of Standard Additions TOC Study	50
10	Results of Standard Dilution TOC Study	52
11	Results of COD Analyses of Particulate-Containing Samples . . .	53

ACRONYMS

COD	Chemical Oxygen Demand
DOC	Dissolved Organic Carbon
POC	Particulate Organic Carbon
TOC	Total Organic Carbon
TSA	Test Support Accessories
UV	Ultraviolet

INTRODUCTION

During the current phase of Contract DAMD17-76-C-6077, Life Systems, Inc. (LSI) has developed, tested and evaluated the Breadboard Electrochemical Total Organic Carbon (TOC)/Chemical Oxygen Demand (COD) Analyzer. It is a unique analyzer, based on advanced concepts for monitoring organic solute concentrations in water and wastewater. Although the analyzer reports organic concentrations using the standard indices of TOC and COD, the technology on which it is based is uniquely compatible with low-cost, automated operation with minimal expendables. As a result, advanced versions of the analyzer are anticipated to find wide use in applications requiring inexpensive and simple instrumentation for monitoring organic loading.

During Contract DAMD17-75-C-5070, the conceptual designs of the Electrochemical TOC and COD Analyzers were developed, and a feasibility analysis of them was performed. (1) Both analyzers are based on the principle of oxidation of organic solutes in water using persulfate ($S_2O_8^{2-}$) with sensors to measure either carbon dioxide (CO_2) produced by the oxidation of the organics, or the concentration of persulfate consumed during the oxidation. The CO_2 evolved is proportional to the TOC concentration in the sample and the concentration of persulfate consumed is proportional to the COD content. Analyzer designs include the feature of in situ, electrochemical generation of the persulfate in an electrolyte recycle loop. This feature avoids the requirement of supplying the analyzers with reagents for long periods. The simple design of the analyzers is compatible with automated operation, small size and weight, portability and low cost.

An additional feature of the analyzers is that costly and polluting reagents are not required. The standard COD method and automated variations of it result in the discharge into the environment of significant quantities of dichromate ($Cr_2O_7^{2-}$), silver (Ag^+) and mercury (Hg^{2+}) salts. The Electrochemical TOC and COD Analyzers do not use dichromate or silver salts. The analyzer may use a small amount of mercury salt to avoid certain interferences but it will be retained with the persulfate within the electrolyte recycle loop.

The evaluation of the analyzer designs revealed that many similarities exist between the Electrochemical TOC and COD Analyzers. It was therefore considered possible to combine the CO_2 and persulfate sensors into a single analyzer capable of monitoring both TOC and COD values. Also, this would make it possible to monitor the ratio of COD to TOC. It is believed that in some applications this ratio will serve to distinguish between the types of organic solutes in the water. For example, industrial wastes in a river might be distinguished from humic and fulvic acids by differences in the COD/TOC ratio.

Because of the flexibility in combining sensors in the analyzers to result in a TOC, a COD, or a TOC/COD analyzer, this development may result in more than one analyzer. Each analyzer can be used in specific applications. For applications in which industrial wastes are monitored, a COD analyzer may be useful. In other applications where water is processed for reuse or for con-

(1) References cited in parentheses are listed at the end of this report.

sumption, TOC may be the required water quality index. Therefore, the present analyzer development is anticipated to result in a number of analyzers that can be tailored to specific applications.

The first phase of the present contract involved testing key components of the analyzer. (2) These components are the persulfate generation cell and the TOC and COD sensors. An evaluation of the data obtained with the persulfate generation cell and TOC sensor indicated that with only a moderate hardware development effort they could be readily adapted to advanced versions of the analyzer. The COD sensor, however, required extensive development due to the difficulties in monitoring persulfate concentrations without the use of consumables. The approach to the COD sensor finally selected for the Key Components Evaluation is based on a coulometric technique. This approach satisfies the analytical needs of the analyzer but will require further development to achieve the necessary speed of response and simplified operation for use in advanced analyzers.

The goal of the present phase of the program is to demonstrate the effectiveness of the persulfate oxidation of organics for TOC and COD measurements. Although TOC measurements with the persulfate oxidation technique have been demonstrated previously, as in LSI's Continuous, Chemical TOC Analyzer, COD measurements using the persulfate oxidation technique have not been demonstrated before. To make these measurements, the Breadboard Electrochemical TOC/COD Analyzer was assembled and tested. Specific objectives of the Breadboard Analyzer development are to (1) demonstrate and evaluate TOC and COD measurements using the persulfate oxidation technique, (2) identify the optimum oxidation conditions for measuring TOC and COD, (3) investigate the effects of potential interferences upon the organic oxidation process, (4) investigate the possible effects of oxidation products on the TOC and COD sensors and (5) perform an initial comparison of TOC and COD measurements made with the Breadboard Analyzer and standard methods.

Definitions

Commonly used indices of organic solute concentrations are defined below:

1. Chemical Oxygen Demand (COD): COD represents the oxygen (O_2) equivalents consumed in the chemical oxidation of oxidizable solutes (primarily organic species). The COD in the sample is determined by measuring the quantity of a strong chemical oxidizing agent consumed during oxidation of the solutes. COD is expressed in units of ppm.
2. Dissolved Organic Carbon (DOC): DOC values represent the concentration of soluble carbonaceous organic solutes in the sample and the measurement is based on the concentration of carbon in the solutes. DOC is expressed in units of ppm.
3. Particulate Organic Carbon (POC): POC values represent the concentration of particulate carbonaceous organic material, or carbonaceous material adsorbed on, or entrapped in, organic or inorganic particulates. Particulates are generally defined as material that will not pass through a 0.45μ filter. POC is measured on the basis of the

concentration of carbon in the particulate material, and is expressed in units of ppm.

4. Total Organic Carbon (TOC): TOC is the sum of the concentrations of DOC and POC and is expressed in units of ppm.

Conceptual Design of End Item Analyzer

The conceptual schematic of the Electrochemical TOC/COD Analyzer is shown in Figure 1. To avoid consumption of reagents, an electrolyte recycle loop is part of the design. The electrolyte is required in the analyzer for operation of the electrochemical components and aids the organic oxidation process. The water sample is continuously injected into the electrolyte recycle loop with a flow rate that equals that of the electrolyte. Persulfate is generated in situ in the electrochemical cell shown in the schematic by oxidation of sulfate (SO_4^{-2}) in the electrolyte:

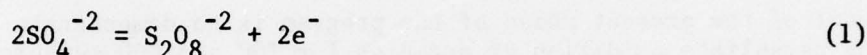

Inorganic carbon contained in the water sample (in the form of carbonate (CO_3^{-2}) or bicarbonate (HCO_3^-)) is converted by the acidic electrolyte to CO_2 :



The CO_2 formed from inorganic carbon would be detected by the TOC sensor and would produce a positive error in the TOC measurement if it was not removed from the electrolyte recycle loop. The inorganic carbon removal is accomplished by means of the inorganic carbon stripper shown schematically in Figure 2. Carbon dioxide formed by acidification of inorganic carbon in the sample diffuses through a membrane in the stripper to a more basic solution on the other side. There the inorganic carbon is reconverted to carbonate. O_3^{-2} . The partial pressure difference of CO_2 between the acidic and basic sides of the membrane results in a driving force for removal of inorganic carbon from the electrolyte.

As part of an Internal Research and Development (IRAD) program that supports the efforts of this contract, LSI developed the Continuous, Chemical TOC Analyzer, shown schematically in Figure 3. The purpose of this IRAD program was to demonstrate the effectiveness of the persulfate oxidation of organics for TOC measurements and to demonstrate the effectiveness of the inorganic carbon stripper concept. The stripper is shown in the Analyzer in Figure 4 and separately in Figure 5.

In the Electrochemical TOC/COD Analyzer, after inorganic carbon has been removed from the electrolyte, the electrolyte contains only organic solutes and persulfate. The oxidation of the organic solutes by persulfate occurs in the ultraviolet (UV) reactor downstream of the inorganic carbon stripper. A typical oxidation is shown in Equation 4 for methanol (CH_3OH):

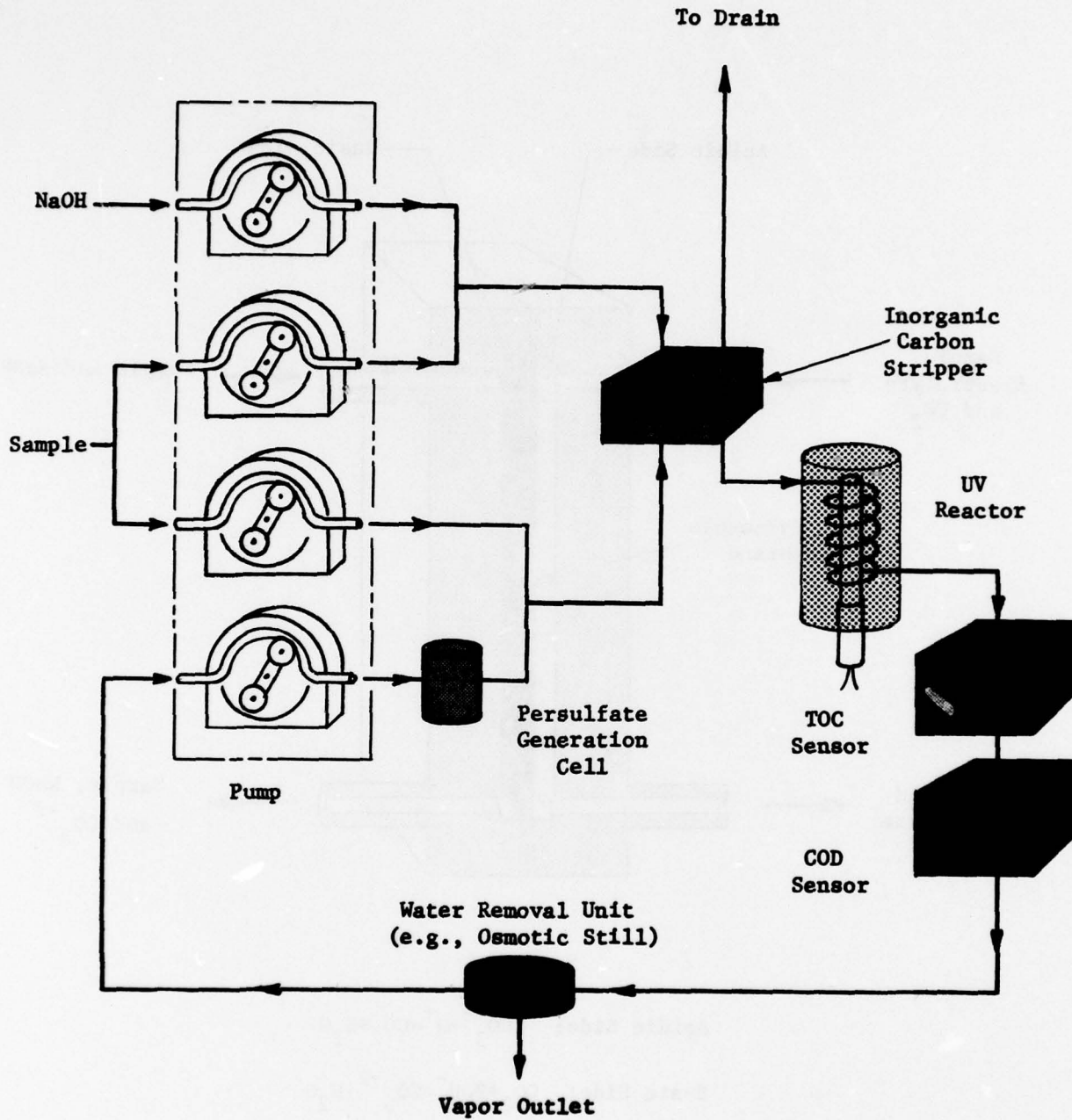

FIGURE 1 SCHEMATIC OF END ITEM ELECTROCHEMICAL TOC/COD ANALYZER

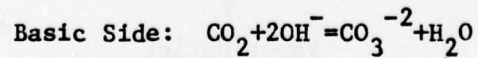
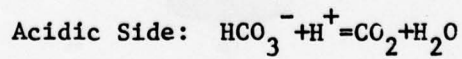
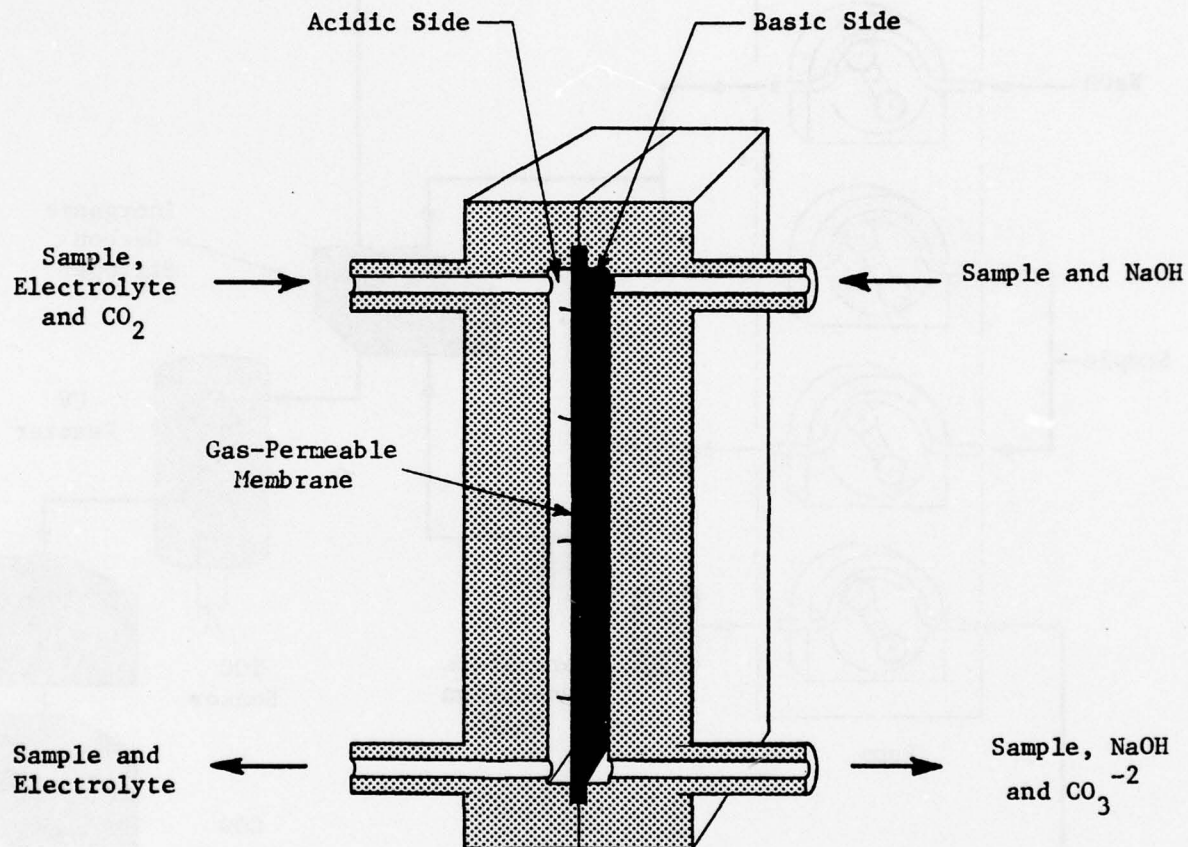

FIGURE 2 INORGANIC CARBON STRIPPER SCHEMATIC

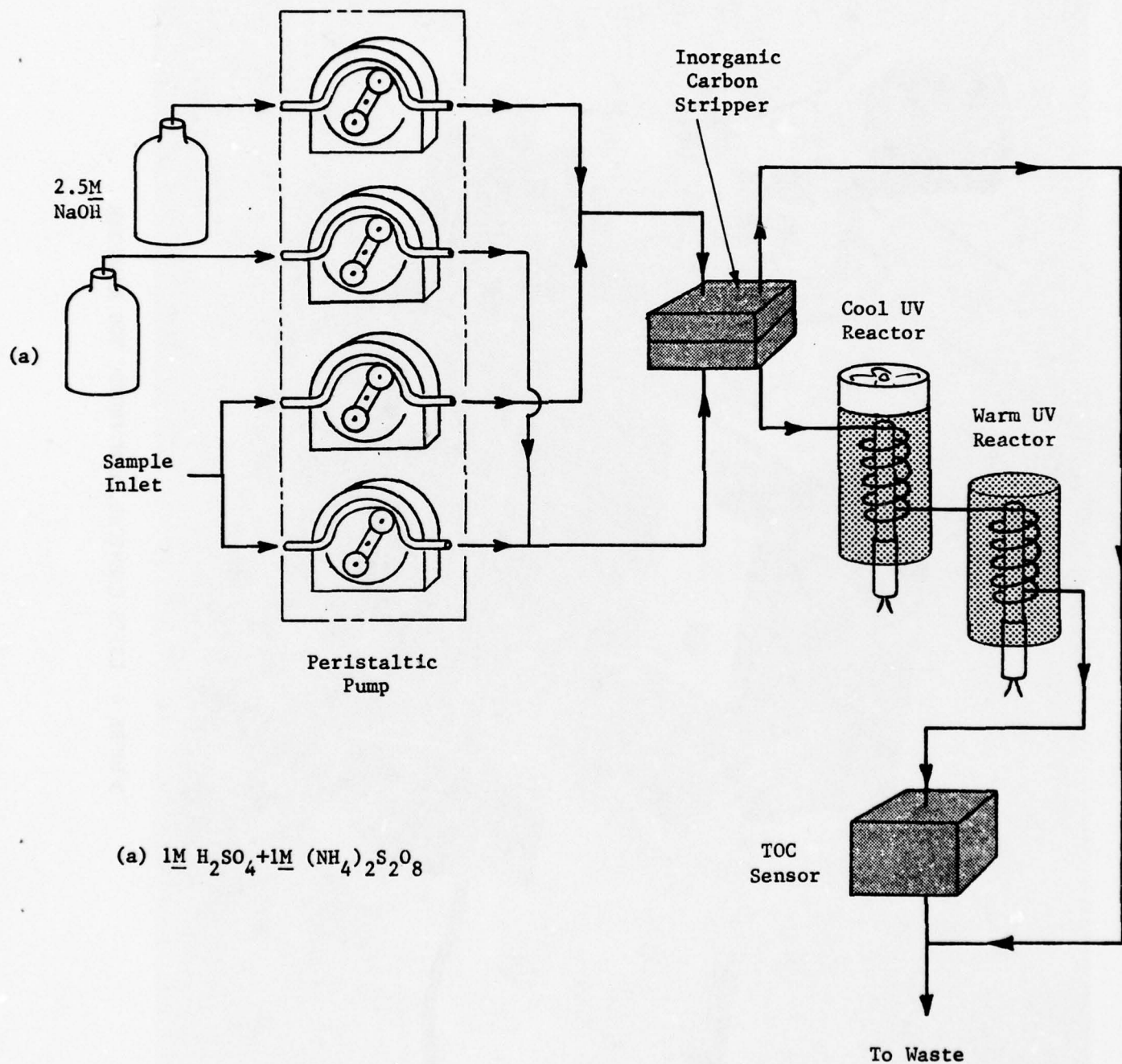

FIGURE 3 CONTINUOUS CHEMICAL TOC ANALYZER SCHEMATIC

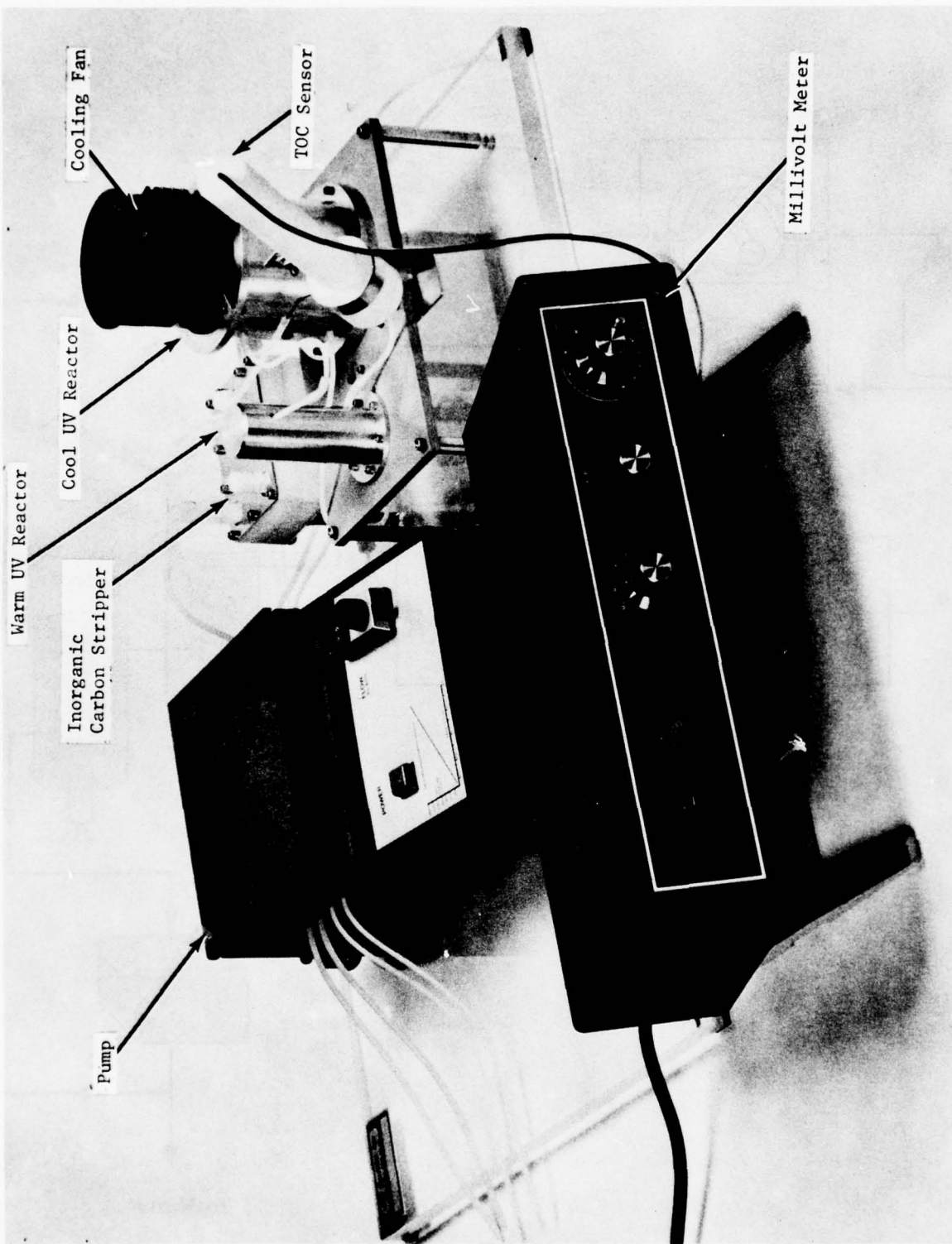

FIGURE 4 LSI'S CHEMICAL, CONTINUOUS TOC ANALYZER

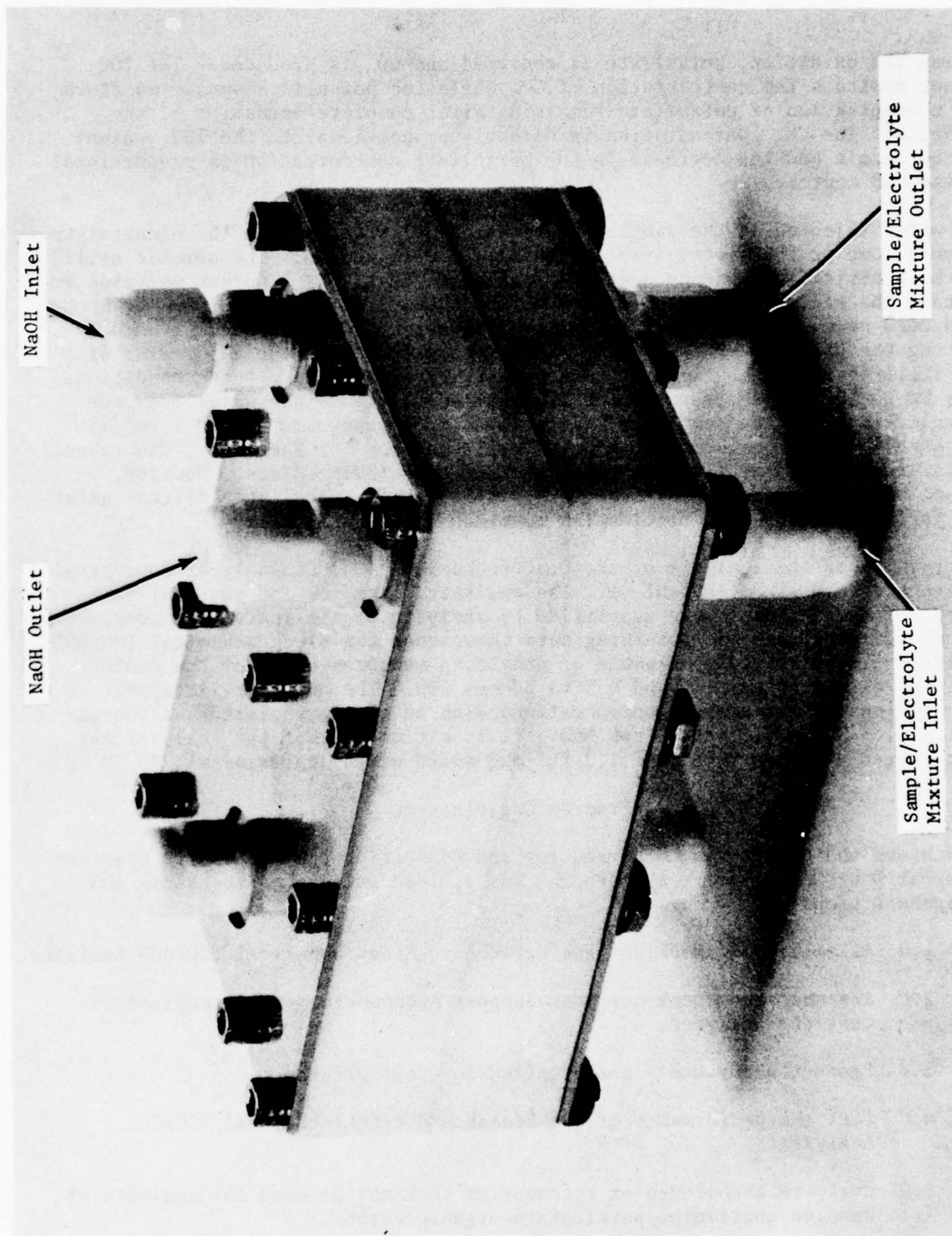
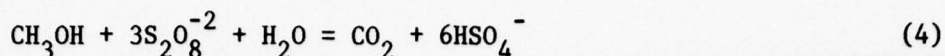

FIGURE 5 BREADBOARD INORGANIC CARBON STRIPPER



During the oxidation, persulfate is consumed and CO_2 is produced. The TOC sensor monitors the concentration of CO_2 while the persulfate sensor monitors the concentration of persulfate remaining after complete oxidation of the organics. The CO_2 concentration is directly proportional to the TOC content of the sample and the decrease in the persulfate concentration is proportional to the COD content.

The water injected at the sample inlet must be eliminated from the electrolyte recycle loop or the electrolyte concentration will change. The osmotic still, which is basically a vacuum distillation device that uses a porous membrane to contain the electrolyte, can eliminate from 6 N sulfuric acid (H_2SO_4) as much as 0.0028 cc/min of water per cm^2 of membrane area. This is accomplished by heating the still to 93 C and controlling the pressure on the vapor side of the still to a value between 2 and 6 psia (Figure 6). Under these conditions only 80 to 90 cm^2 of membrane area is required to remove the water from the recycle loop when the sample and electrolyte flow rates are each 0.1 cm^3/min . The osmotic still has been documented in literature.⁽⁵⁾ Therefore, the capability of removing water from the electrolyte recycle loop exists. However, future work may indicate that simpler, smaller and more reliable devices exist for performing the water elimination function in the analyzer.

The results of the analysis of the Electrochemical TOC/COD Analyzer conceptual design are summarized in Table 1. The analytical, system and physical parameters of the analyzer were quantified by analysis of the individual components of the analyzer, and the resulting data shows that the Electrochemical TOC/COD Analyzer is theoretically capable of providing measurements over the minimum range of 0.1 to 10 ppm TOC and 0.5 to 30 ppm COD. The analyzer is capable of determining organic solute concentrations with an accuracy of $\pm 10\%$ at concentrations of 5 ppm TOC and 10 ppm COD.³ It is estimated that the analyzer may be packaged within a volume of 1.3 ft^3 and would weigh approximately 70 lb.

Program Organization

To achieve the objectives of developing and evaluating the Breadboard Electrochemical TOC/COD Analyzer, the program was divided into seven technical and management tasks:

- 1.0 Assemble and check out the Breadboard Electrochemical TOC/COD Analyzer.
- 2.0 Assemble and check out Test Support Accessories (TSA) required to test the analyzer.
- 3.0 Product Assurance - not required for this program.
- 4.0 Test the performance of the Breadboard Electrochemical TOC/COD Analyzer.
- 5.0 Evaluate techniques or accessories that may be used for analysis of samples containing particulate organic carbon.

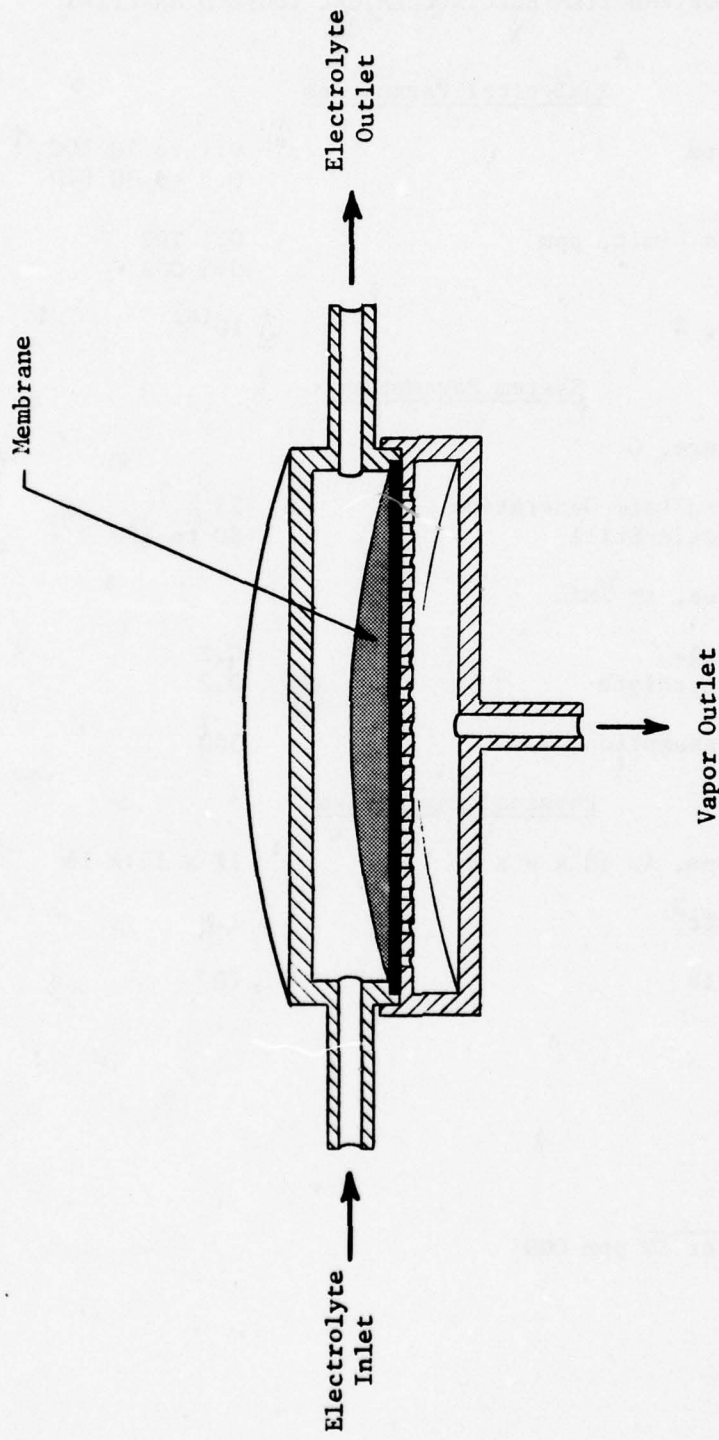

FIGURE 6 OSMOTIC STILL SCHEMATIC

TABLE 1 PRELIMINARY DESIGN GOALS AND SPECIFICATIONS
OF END ITEM ELECTROCHEMICAL TOC/COD ANALYZER

Analytical Parameters

Range, ppm	0.1 to 10 TOC 0.5 to 30 COD
Detection Limit, ppm	0.1 TOC 0.5 COD
Accuracy, %	10 ^(a)

System Parameters

Temperature, C	
Persulfate Generation Cell	25
Osmotic Still	80 to 100
Flow Rates, cm ³ /min	
Sample	0.2
Electrolyte	0.2
Power Consumption, W	300

Physical Parameters

Dimensions, in (H x W x D)	12 x 12 x 16
Volume, ft ³	1.3
Weight, lb	70

(a) At 5 ppm TOC or 10 ppm COD

- 6.0 Incorporate the Contractor's data management functions to provide internal procedures for control of the collection, preparation, quality, assessment, distribution and maintenance of data.
- 7.0 Incorporate the management needed to successfully meet the program's cost, schedule and technical performance requirements, to coordinate with the Technical Monitors through telephone discussions and to result in Customer satisfaction.

BREADBOARD ELECTROCHEMICAL TOC/COD ANALYZER

The design objectives of the Breadboard Analyzer and the components used in it are described below.

Design Objectives

The Breadboard Analyzer was developed to investigate the efficiency of the UV-catalyzed oxidation of organics by persulfate, to optimize the conditions for that oxidation and to investigate the effects of potential interferences. The objectives of the analyzer design effort, therefore, were to provide the capability for measuring the efficiency of the oxidation and to provide the flexibility required to optimize the oxidation conditions. The TOC and COD sensors were used to measure oxidation efficiency, while flexibility was achieved by manually performing some functions that would be performed automatically in the end item analyzer. The major parameters that can be adjusted to optimize the oxidation process are the electrolyte composition, the persulfate concentration and the residence time in the UV reactor.

Another objective of the Breadboard Analyzer development was to provide instrumentation for testing the TOC and COD sensors using the exact conditions they would experience in the end item Electrochemical TOC/COD Analyzer. Although they had been tested during the Key Components Evaluation, they had not been exposed to oxidation products from the UV reactor prior to the Breadboard Analyzer testing.

Analyzer Design

A schematic of the Breadboard Analyzer is shown in Figure 7. A peristaltic pump is used to introduce the sample and electrolyte solutions into the analyzer. Electrochemical generation of persulfate is simulated by manual addition of persulfate to the electrolyte solution. The function of the inorganic carbon stripper is simulated manually by acidification of the sample and sparging to remove inorganic carbon prior to analysis.

The sample and electrolyte solutions are mixed and enter the UV reactor in which the organic oxidation occurs. The solution then continues to the TOC sensor which measures the concentration of CO_2 resulting from the oxidation. From the TOC sensor the solution flows into an injection valve that is used to manually inject a portion of the sample/electrolyte solution into the COD sensor. The amount of persulfate remaining in the solution after the organic oxidation is measured by the COD sensor and can be related to the COD content of the sample. The electronic components of the analyzer consist mainly of a

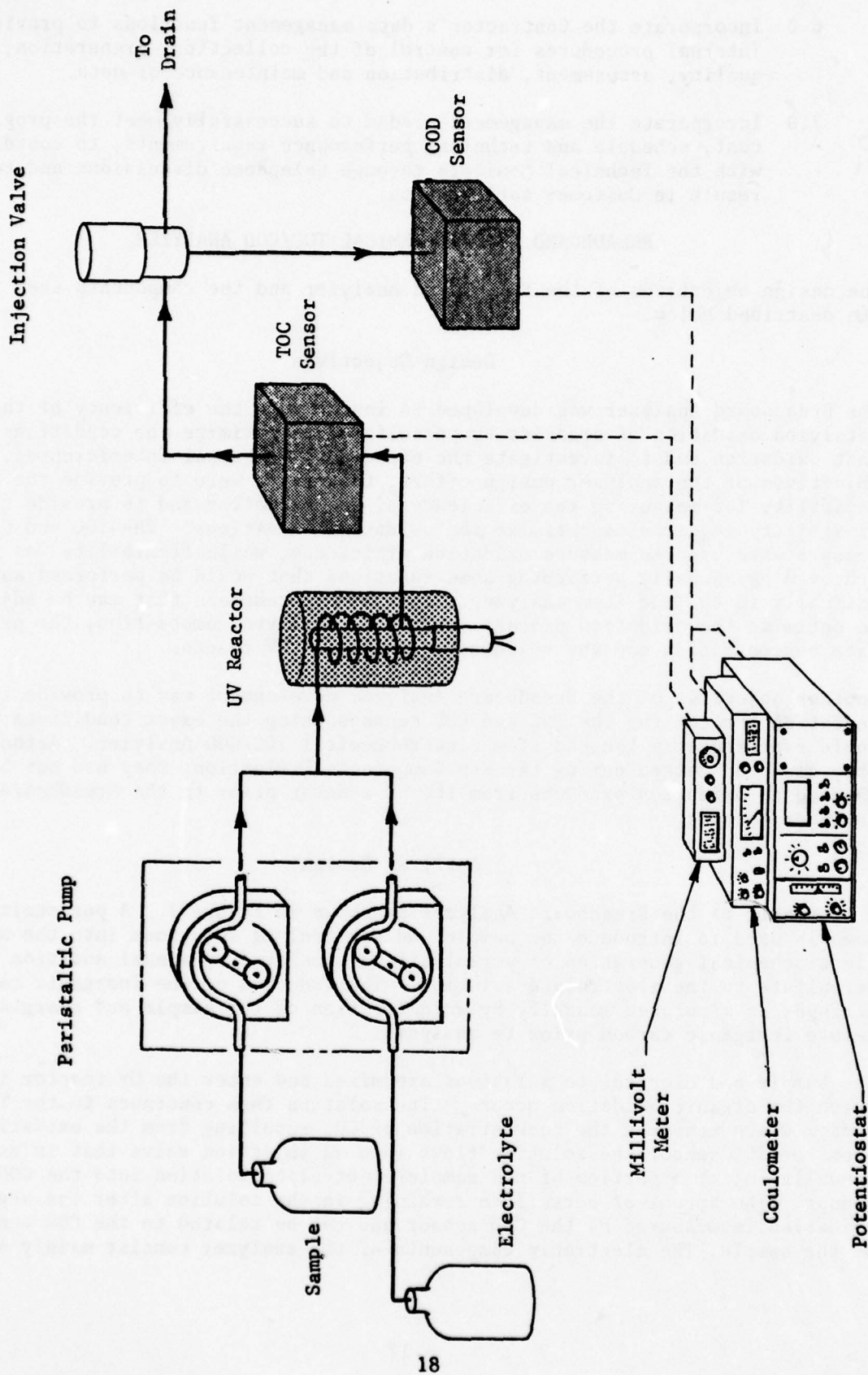

FIGURE 7 SCHEMATIC OF BREADBOARD ELECTROCHEMICAL TOC/COD ANALYZER

millivolt meter, a potentiostat and a coulometer. These components are shown in Figure 8.

UV Reactors

Two UV reactors were developed for the Continuous, Chemical TOC Analyzer and were adapted for use in the Breadboard Analyzer. Both reactors contain quartz coils surrounding UV lamps (Figure 9). However, one reactor is closed and warmed by the heat emitted by the lamp. The second reactor is open and cooled by ambient air drawn through the reactor by a cooling fan.

The UV reactors were integrated into the Breadboard Analyzer to permit use of one or both of the reactors, as required, to achieve optimum performance.

TOC Sensor

The TOC sensor monitors the concentration of CO₂ produced by the oxidation of organic solutes. The sensor consists of a probe covered with a gas-permeable membrane as shown schematically in Figure 10. The acidic sample/electrolyte mixture is pumped along one side of the membrane and CO₂ from that solution diffuses through the membrane into the less acidic internal filling solution in the sensor. The CO₂ dissolves in the internal filling solution, increasing its acidity:

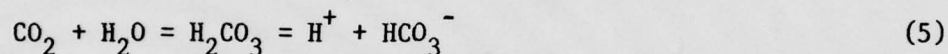

The pH change in the internal filling solution is monitored by a glass pH electrode and a reference electrode inside the sensor. The response of the sensor, E, is proportional to the CO₂ partial pressure in the sample, as shown in Equation 6:

$$E = E' - 2.303 \frac{RT}{F} \log p\text{CO}_2 \quad (6)$$

where

- E' = Constant, V.
- R = Universal Gas Constant, joules/K
- T = Temperature, K
- F = Faraday's Constant, coulombs/equivalent
- pCO₂ = Partial pressure of CO₂, atm

Since the partial pressure of CO₂ in the sample is directly related to the TOC concentration, the response of the sensor is proportional to TOC.

COD Sensor

The coulometric persulfate sensor is shown schematically in Figure 11. The cell consists of a large mercury (Hg) pool working electrode with the counter and reference electrodes separated from the test solution by fritted disks. A volume of the sample/electrolyte mixture is introduced into the cell by the sample injection valve. The working electrode is maintained at a constant potential at which only persulfate is reduced:

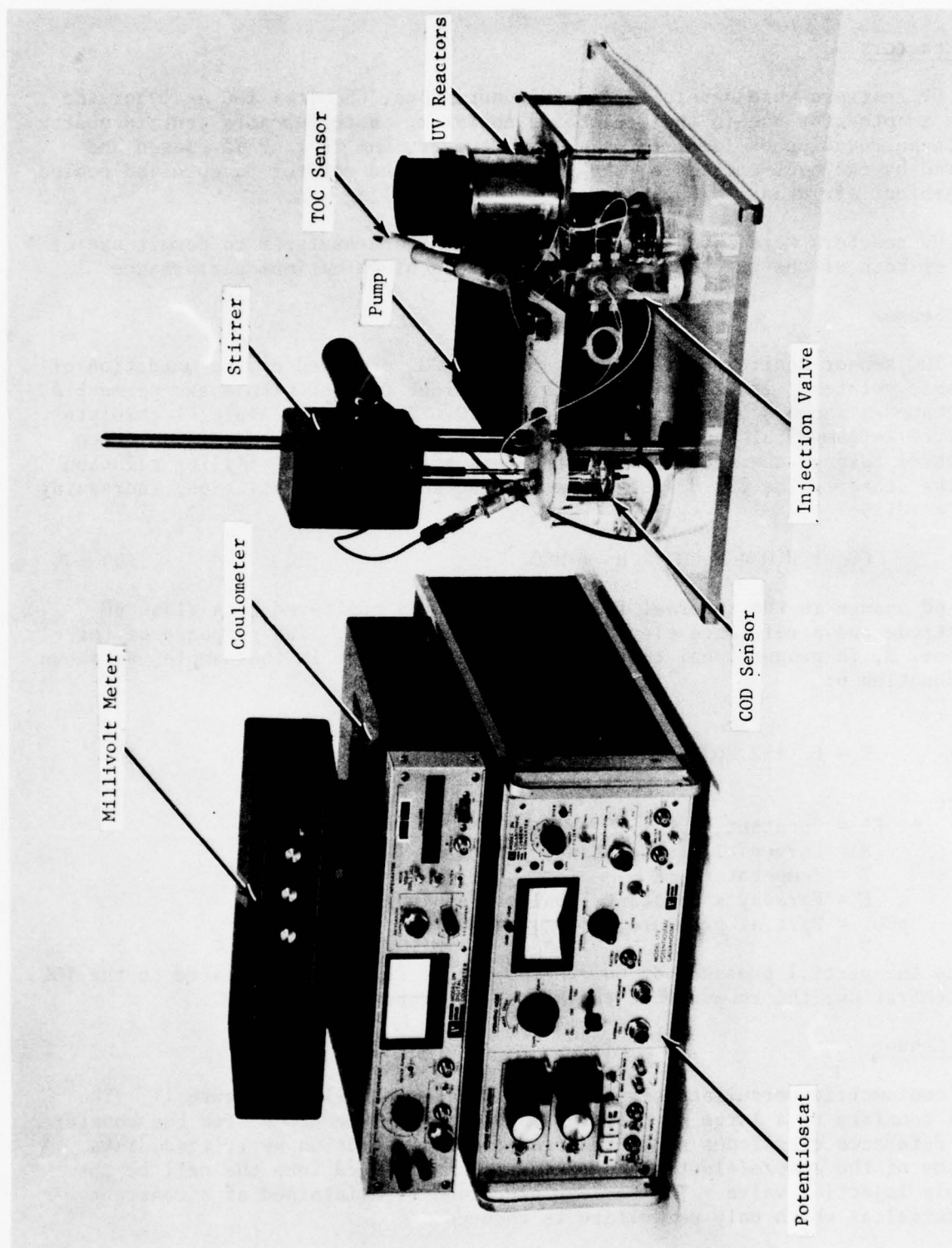

FIGURE 8 BREADBOARD ELECTROCHEMICAL TOC/COD ANALYZER

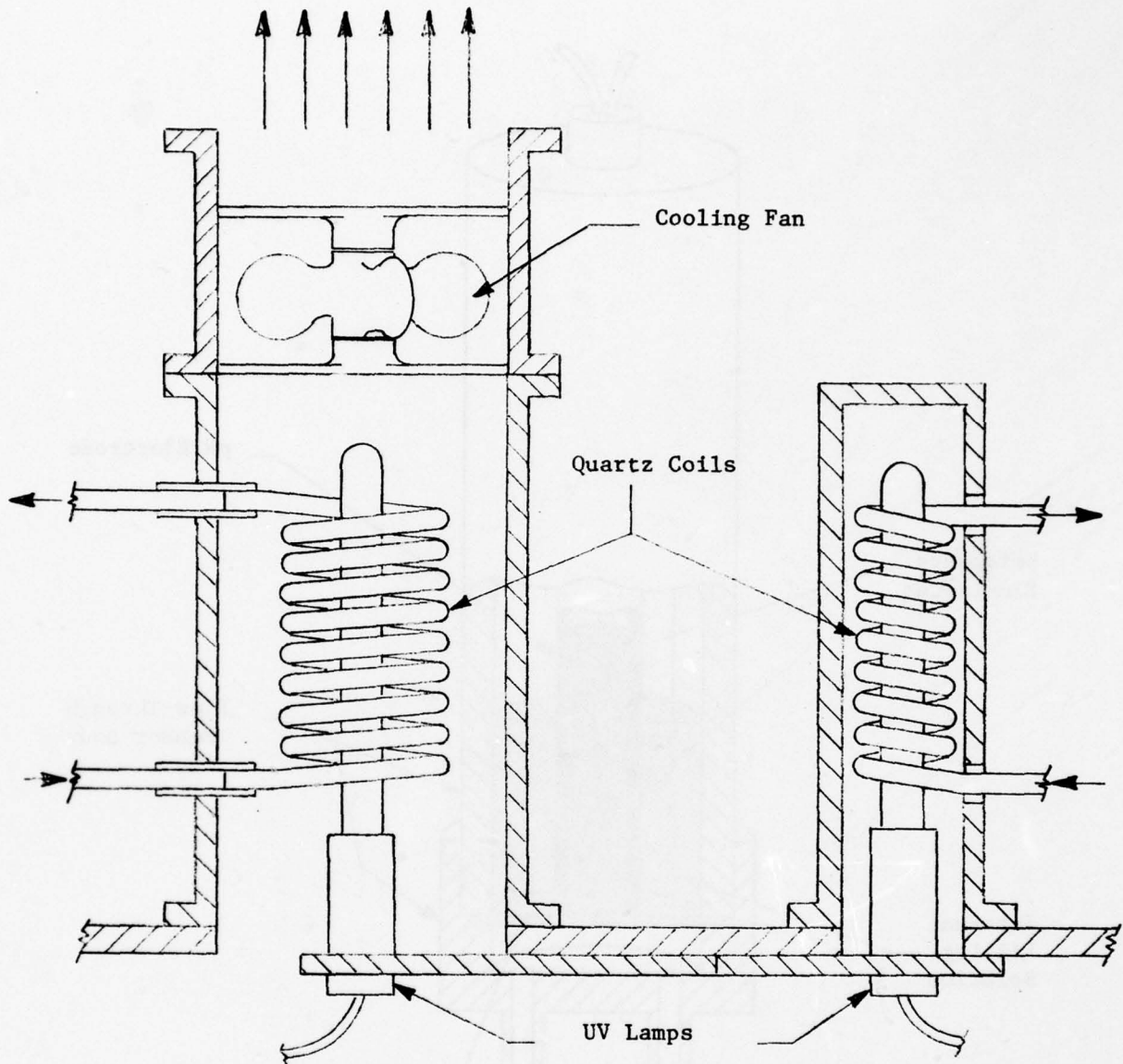

FIGURE 9 UV REACTORS SCHEMATIC

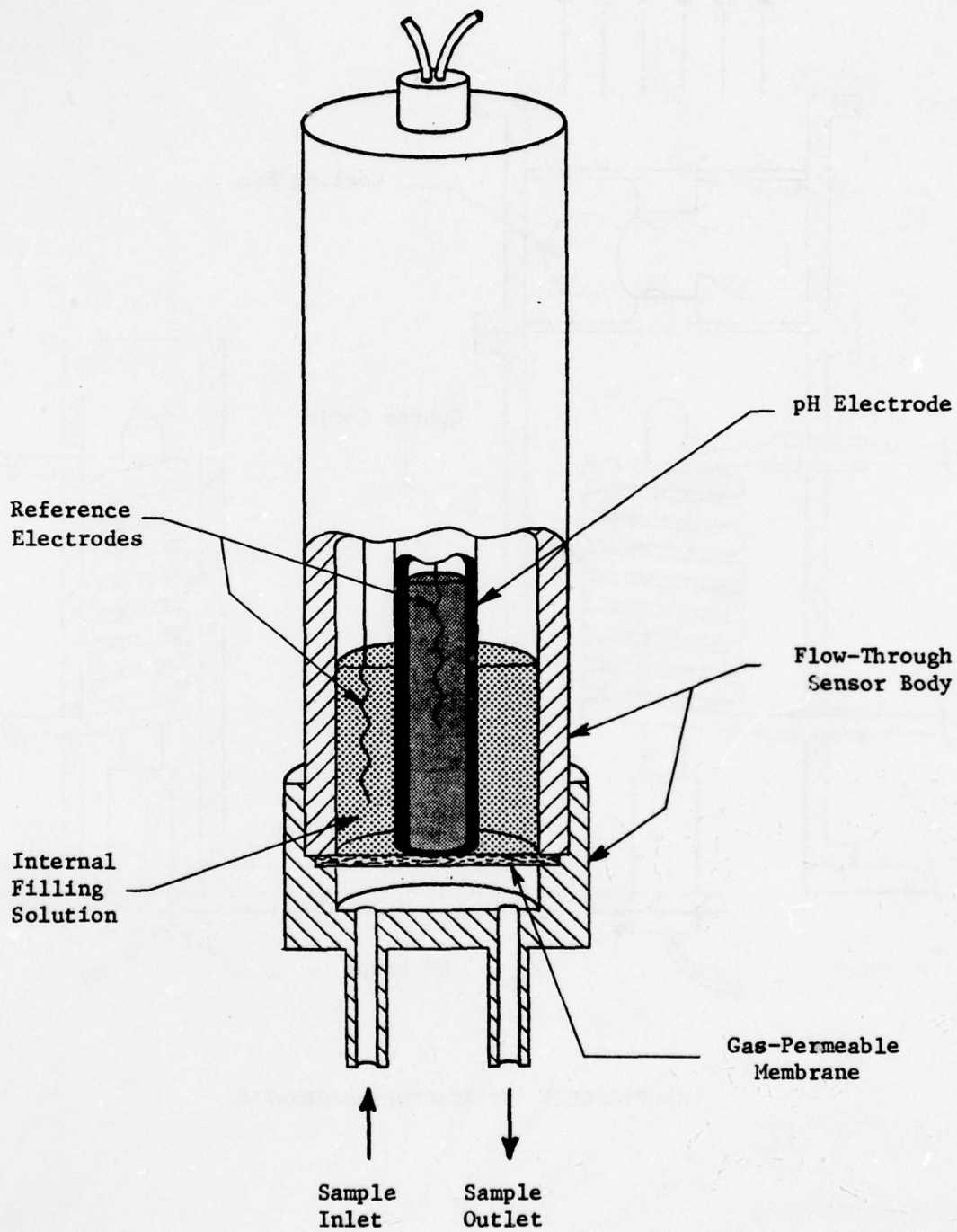

FIGURE 10 TOC SENSOR SCHEMATIC

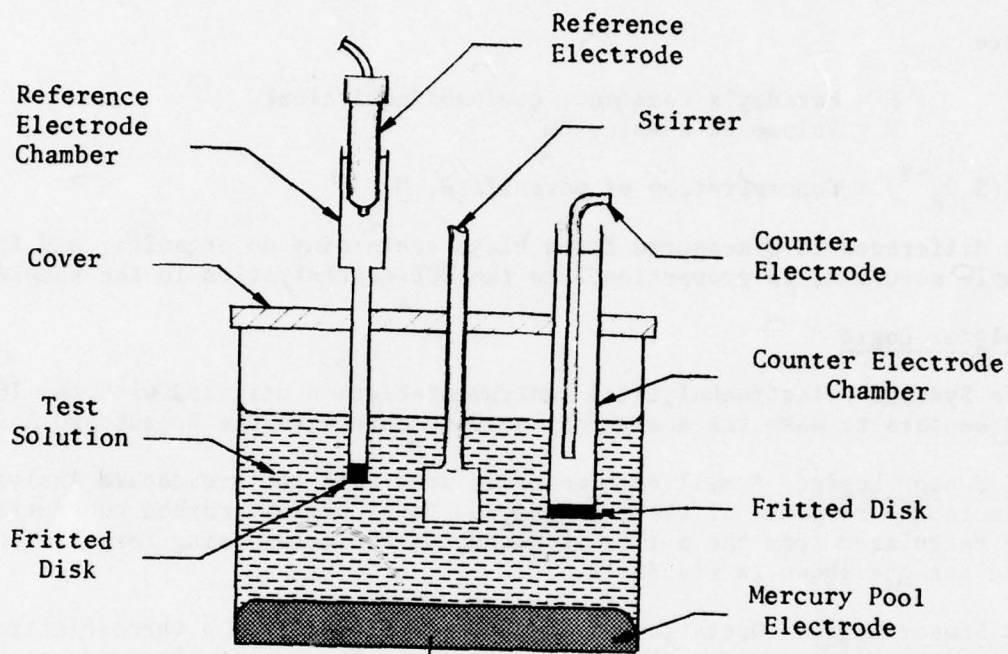

FIGURE 11 COD SENSOR SCHEMATIC



Therefore, when a portion of the sample/electrolyte mixture is injected, the charge, Q, required to reduce the persulfate in the solution is proportional to the concentration of persulfate remaining after the organic oxidation:

$$Q = \frac{FV}{500} (S_2O_8^{-2}) \quad (8)$$

where

F = Faraday's Constant, coulombs/equivalent

V = Volume of sample, cm³

(S₂O₈⁻²) = Concentration of persulfate, M

The difference in Q measured for a blank containing no organics, and for the sample solution, is proportional to the COD concentration in the sample.

Analyzer Logic

Life Systems' electroanalytical instrumentation is utilized with the TOC and COD sensors to make the analytical measurements with the Breadboard Analyzer.

TOC Sensor Logic. A millivolt meter is used with the Breadboard Analyzer to measure the response of the TOC sensor. Total organic carbon concentrations are calculated from the millivolt output of the meter using response curves like the one shown in Figure 12.

COD Sensor Logic. Operation of the COD sensor requires a three-electrode potentiostat to maintain the potential of the Hg working electrode at the optimum potential for persulfate reduction. Current flowing through the Hg electrode is integrated with a digital coulometer. The coulometer is manually reset prior to injection of a fresh portion of the sample/electrolyte mixture into the COD sensor and is allowed to integrate the current until all persulfate is reduced. The coulometer employs a background compensation feature to compensate for the small residual current that always flows through the electrodes. The response of the sensor to solutions containing various persulfate concentrations is shown in Figure 13.

Other Circuitry

Certain other electrical components are required in the Breadboard Analyzer. For example, power supplies are required for the UV lamps. Power controls are used with the pump, the cooling fan in the UV reactor and in the stirrer used with the COD sensor. Future advanced versions of the analyzer will probably centralize the controls of these circuits for simplified operation.

TEST SUPPORT ACCESSORIES

The TSA consists of all equipment and hardware necessary for testing the Breadboard Analyzer. The TSA also includes equipment for standard TOC and COD

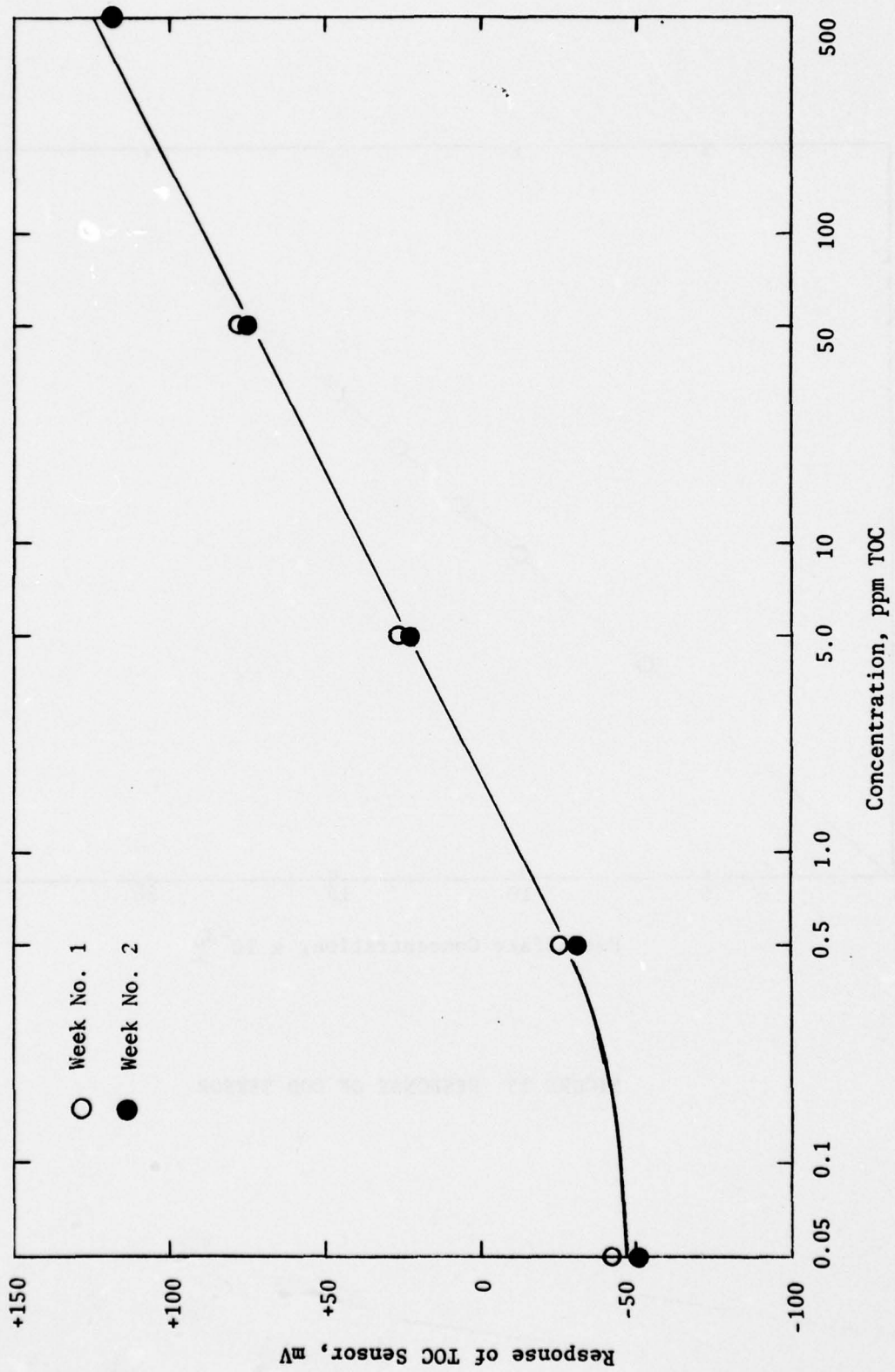

FIGURE 12 TOC SENSOR RESPONSE

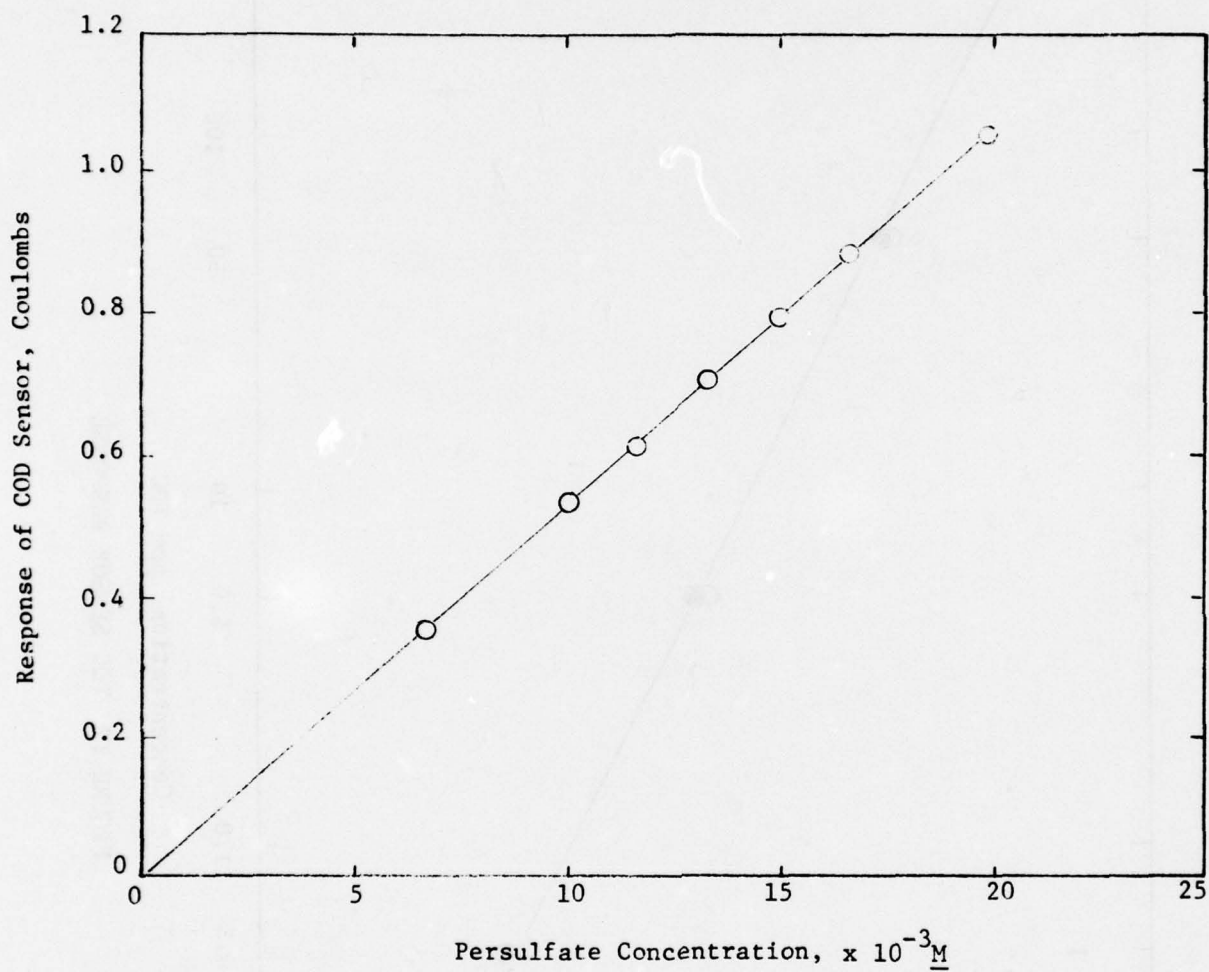

FIGURE 13 RESPONSE OF COD SENSOR

analyses. Life Systems' Dohrmann DC-50 TOC analyzer employs reductive pyrolysis followed by flame ionization detection of methane (CH_4). Samples are usually injected into the analyzer through a septum. For samples containing particulates, however, the sample injection technique was modified to allow injection with an autopipet.⁽⁴⁾

The standard COD method used by LSI utilizes a two-hour reflux with an acidic dichromate solution.⁽⁵⁾ However, it is recognized that in this method volatile organics can be lost⁽⁶⁾ and it was anticipated that the standard method might yield lower COD values than the Breadboard Analyzer.

Synthetic samples and standard solutions were prepared on a weight or volume basis. Concentrations were confirmed by standard TOC or COD analyses when necessary.

TEST PROGRAM

Tests were performed to initially check out the Breadboard Analyzer and then to optimize the parameters involved with the organic oxidation. Potential interferences were investigated to identify methods of minimizing their effects if any were found. Synthetic and real samples were analyzed then to evaluate the performance of the Breadboard Analyzer. The synthetic samples contained selected individual organic solutes of special interest and the real samples ranged from tap water to raw sewage. Samples containing particulates and particulate-free samples were analyzed.

Checkout Tests

Checkout tests of the TOC and COD sensors and the UV reactors were performed after assembly of the Breadboard Analyzer. The TOC sensor was calibrated using solutions containing sodium bicarbonate (NaHCO_3). Its response was very similar to that obtained during the Key Components Evaluation.

The COD sensor was calibrated using solutions containing known concentrations of persulfate. The response of the sensor agreed closely with that obtained during the previous Key Components Evaluation. However, during the checkout test of the COD sensor it was discovered that when the persulfate solution was pumped through the warm UV reactor, a significant decrease in the persulfate concentration⁽⁷⁾ occurred. Since thermal decomposition of persulfate has been documented, this decrease was attributed to the heat in the warm reactor. The cool reactor caused little loss of persulfate and subsequent tests were performed with the cool reactor.

A functional checkout of the UV reactor was performed using a sample containing the primary standard, potassium hydrogen phthalate (KHP). The organic concentration was 100 ppm TOC and the oxidation efficiency was 43% as determined with the TOC sensor. The concentration of ammonium persulfate ($(\text{NH}_4)_2\text{S}_2\text{O}_8$) was 0.05 M and the electrolyte was 5.0 M ammonium bisulfate (NH_4HSO_4). The residence time in the UV reactor was 40 sec.

Parametric Tests

The parametric tests were performed to optimize the conditions for organic oxidation in the Breadboard Analyzer. The parameters that are available for optimization are the electrolyte composition, the persulfate concentration in the electrolyte and the residence time in the UV reactor. Certain requirements for the optimization are inherent in the nature of the measurements. For example, TOC measurements require complete oxidation of the organic solutes. The oxidation can be expected to be most complete when the organics are mixed with large amounts of the oxidizing agent and exposed to heat and UV radiation. Therefore, the measurement of TOC concentration is facilitated by large persulfate concentrations, use of the warm UV reactor and long exposure to the UV radiation.

On the other hand, COD determinations are difference measurements. It is the decrease in the initial persulfate concentration after the oxidation that is related to the COD content of the sample. Since small differences in large numbers are difficult to measure precisely, it is beneficial for the COD measurement to utilize as low a persulfate concentration as possible while still resulting in complete oxidation of the organics. Also, since heat causes thermal decomposition of persulfate, it is necessary to avoid heating the solution so that the COD measurement is not complicated by a loss of persulfate not related to the COD content of the sample.

Four organic solutes were selected for use in the parametric tests. These were KHP, methanol, pyridine and acetic acid. It was concluded that for optimization of the oxidation, one of the more refractory organics would be used. This organic was identified by oxidizing each of the four organic solutes with 0.05 M persulfate and a UV residence time of 40 sec. The electrolyte previously used in the Key Components Evaluation was 5.0 M NH_4HSO_4 and this electrolyte was also used during the parametric test. Solutions of each of the organic solutes at a concentration of 100 ppm TOC were prepared. With these samples it was found that the oxidation of methanol was 84% complete. Acetic acid was oxidized with 55% efficiency, while the efficiencies of the KHP and pyridine oxidations were 43 and 21%, respectively. Since KHP was only partially oxidized and is a primary standard, it was selected as the baseline solute during the optimization tests so that accurate standard solutions could be prepared on a weight basis.

These initial measurements of oxidation efficiency were made using the TOC sensor, which operated normally. However, subsequent tests with the COD sensor showed that COD measurements were not reproducible and the sensor response was not linearly related to COD concentration (Figure 14). This nonlinearity was traced to the oxidation of the ammonium ion (NH_4^+) in the electrolyte by persulfate. The oxidation of NH_4^+ seems to occur in parallel with the oxidation of organic solutes but varies depending upon the organic solute and its concentration in the sample. The effect was eliminated by replacing the ammonium bisulfate electrolyte with sodium bisulfate (NaHSO_4).

A second optimized parameter was the concentration of persulfate. The design specifications required the Breadboard Analyzer to operate over the range of 0.1 to 10 ppm TOC and 0.5 to 30 ppm COD. It was recognized during the parametric

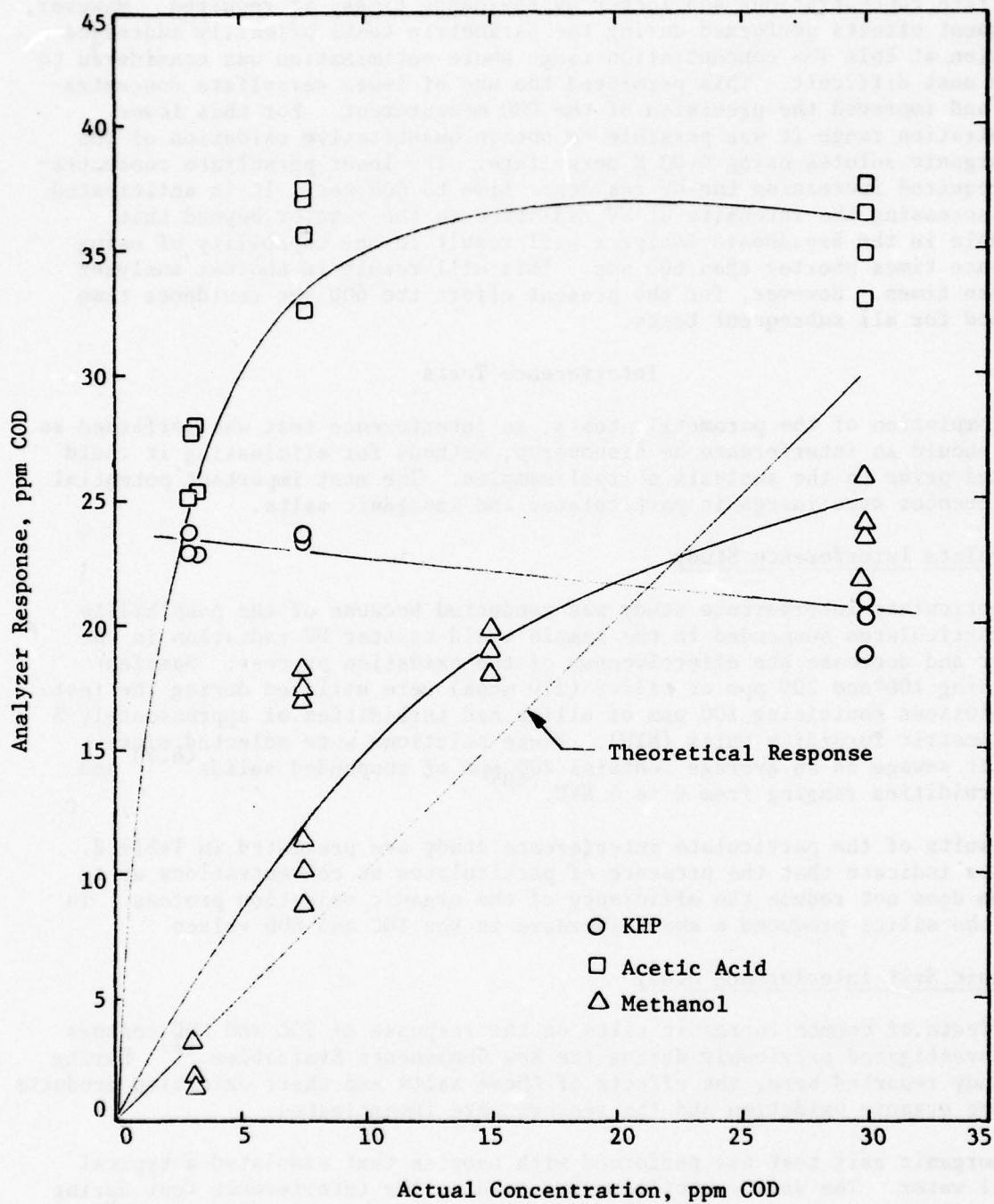

FIGURE 14 COD RESPONSE OF BREADBOARD ANALYZER WITH NH_4HSO_4 ELECTROLYTE

tests that higher concentrations could readily be analyzed by using large persulfate concentrations and longer UV residence times, if required. However, subsequent efforts performed during the parametric tests primarily addressed operation at this low concentration range where optimization was considered to be the most difficult. This permitted the use of lower persulfate concentrations and improved the precision of the COD measurement. For this lower concentration range it was possible to obtain quantitative oxidation of the four organic solutes using 0.03 M persulfate. The lower persulfate concentration required increasing the UV residence time to 600 sec. It is anticipated that increasing the intensity of UV radiation in the reactor beyond that available in the Breadboard Analyzer will result in the capability of using residence times shorter than 600 sec. This will result in shorter analyzer response times. However, for the present effort the 600 sec residence time was used for all subsequent tests.

Interference Tests

Upon completion of the parametric tests, an interference test was performed so that, should an interference be discovered, methods for eliminating it could be found prior to the analysis of real samples. The most important potential interferences were inorganic particulates and inorganic salts.

Particulate Interference Study

The particulate interference study was conducted because of the possibility that particulates suspended in the sample would scatter UV radiation in the reactor and decrease the effectiveness of the oxidation process. Samples containing 100 and 200 ppm of silica (270 mesh) were utilized during the test. The solutions containing 200 ppm of silica had turbidities of approximately 5 Nephelometric Turbidity Units (NTU). These solutions were selected since domestic sewage on an average contains 200 ppm of suspended solids^(8,9) and has turbidities ranging from 0 to 5 NTU.⁽¹⁰⁾

The results of the particulate interference study are presented in Table 2. The data indicate that the presence of particulates at concentrations up to 200 ppm does not reduce the efficiency of the organic oxidation process. In fact, the silica produced a small increase in the TOC and COD values.

Inorganic Salt Interference Study

The effects of common inorganic salts on the response of TOC and COD sensors were investigated previously during the Key Components Evaluation.⁽²⁾ During the study reported here, the effects of these salts and their oxidation products upon the organic oxidation and the sensors were investigated.

The inorganic salt test was performed with samples that simulated a typical natural water. The same composition was used in the interference test during the Key Components Evaluation. The water contained 150 ppm chloride (Cl^-), 10 ppm nitrogen (N_2) as nitrate (NO_3^-/N) and 0.3 ppm ferrous ion (Fe^{+2}). It was further assumed that prolonged analysis of this water would result in the accumulation of these ions in the electrolyte recycle loop, where Fe^{+2} would be oxidized quickly by persulfate to the ferric state (Fe^{+3}). Therefore the

TABLE 2 RESULTS OF INORGANIC PARTICULATES STUDY

Sample	Particulates Concentration, ppm	TOC Concentration, ppm		COD Concentration, ppm	
		Measured	Actual	Measured	Actual
Distilled Water	0	0	0	0	0
Particulate Sample No. 1	100	0	0	0	0
Particulate Sample No. 2	200	0	0	0	0
KHP Standard	0	5.0	5.0	12.5	12.5
Particulate Sample No. 3	100	5.0	5.0	18.8	12.5
Particulate Sample No. 4	200	6.2	5.0	19.4	12.5

test solutions used during this investigation represented three points during a month of continuous analysis of the water sample; one sample simulated initial analysis of the water before accumulation of any salts in the electrolyte, while the other two samples represented the concentrations of salts that would accumulate in the electrolyte recycle loop after 15 and 30 days of operation. To investigate the possible effects of these salts upon the organic oxidation process, the solutions also contained KHP at a concentration of 5 ppm TOC.

In Table 3 the analyses of these solutions are compared to the analyses of a distilled water blank and a KHP solution that contained no salts. These data show a large positive error for both TOC and COD measurements, even for the solution containing the lowest salt concentrations. Subsequent tests of the individual salts showed that Cl^- caused an error in the TOC measurement when the concentration of Cl^- was greater than 50 ppm. The maximum Cl^- concentration that could be analyzed without a significant error in the COD measurement was determined to be approximately 1 ppm Cl^- .

The effects of Cl^- are attributed to the fact that Cl^- is oxidized by persulfate to chlorine (Cl_2). From the decrease in the amount of persulfate when Cl^- is present, as measured by the COD sensor, it can be shown that the oxidation of Cl^- by persulfate is not a simple stoichiometric reaction. Rather, the Cl^- appears to cause a chain reaction that results in the loss of many times more persulfate than would be normally expected. Chain reactions of this sort involving persulfate have been reported before for solutions containing cupric ions (Cu^{+2}) or arsenious acid (H_3AsO_3).⁽⁷⁾ In these cases water was oxidized by highly reactive reaction intermediates. Data obtained with the Breadboard Analyzer have shown that the Cl^- oxidation consumes between 7 and 16 times as much persulfate as anticipated from the stoichiometry of the reaction. The overall reaction can be summarized by Equation 9:

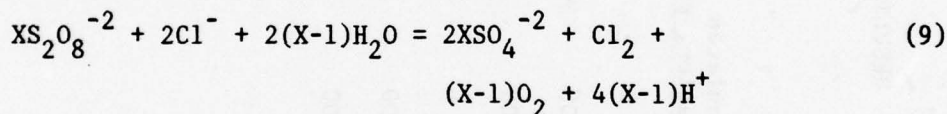

where $\text{X} = 1$ or greater

The effect on the COD measurement results because the oxidation of Cl^- consumes persulfate. The effect on the TOC measurement is attributed to the effect of the Cl_2 on the TOC sensor. The Cl_2 can diffuse through the gas-permeable membrane into the internal filling solution. There the Cl_2 disproportionates according to Equation 10:

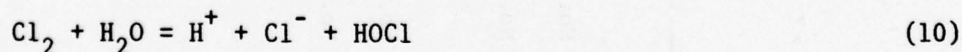

The formation of hydrogen ions (H^+) increases the acidity of the filling solution, causing a large positive error.

The effect of Cl^- upon both the TOC and COD measurements was eliminated by the addition of mercuric sulfate (HgSO_4) to the electrolyte. This approach is also used in the standard COD method.⁽⁵⁾ It is based upon complexation of the Cl^- by mercuric ions (Hg^{+2}) to form an unreactive species which is not oxidized by persulfate:

TABLE 3 RESULTS OF INORGANIC SALTS STUDY

Sample	Ion Concentrations, ppm				TOC		COD	
	Cl ⁻	NO ₃ ⁻ /N	Fe ⁺²	Fe ⁺³	Measured	Actual	Measured	Actual
Distilled Water	0	0	0	0	0	0	0	0
KHP Standard	0	0	0	0	5.0	5.0	12.5	12.5
Simulated Natural Water Samples (a)								
1st Day	150	10.2	0.3	0	>10 ⁵	5.0	358	12.5
15th Day	1280	84.0	0	2.6	>10 ⁵	5.0	308	12.5
30th Day	2560	168	0	5.2	>10 ⁵	5.0	270	12.5

(a) Containing KHP



The effectiveness of this approach is shown by Table 4 in which data from the analysis of a solution containing 150 ppm Cl^- with and without Hg^{+2} are presented. Upon the basis of this data, HgSO_4 was added to the electrolyte for all further analyses.

Sample Analysis

Upon completion of the interference tests the performance of the Breadboard Analyzer was evaluated by analysis of synthetic and real samples.

Synthetic Samples

Synthetic samples containing KHP, methanol, urea, pyridine and acetic acid were analyzed. With these samples the response of the analyzer was compared to the known concentrations of the solutions. Urea, pyridine and acetic acid were selected because they were considered to be relatively refractory. Methanol was selected because of its volatility and KHP was selected because it is commonly used as a standard for TOC and COD analyses.

TOC Analyses. The response of the Breadboard Analyzer is shown in Figure 15 for the five organics. This data shows that its response agrees closely with the actual concentrations of the solutions over the range of 1 to 12 ppm TOC.

Total organic carbon data accumulated over the course of the testing program is presented in Figure 16. These data were obtained during various tests with many different samples. The calculated least squares line through these data points has a slope of 1.0075. This verifies that the Breadboard Analyzer is capable of measuring TOC values accurately over this concentration range with a variety of organics.

The response of the Breadboard Analyzer was also investigated for lower and higher concentration ranges. The low range was investigated using standard solutions containing KHP. In Figure 17 the response of the Analyzer is shown for concentrations as low as 0.05 ppm TOC. The response is precise but the slope of the response varies somewhat from the theoretical slope calculated on the basis of the analyzer's response to standard solutions of NaHCO_3 . This discrepancy is considered to be due to the lower sensitivity of the sensor for TOC concentrations below 1 ppm (Figure 12). Nevertheless, the data in Figure 17 shows that the analyzer can be used to detect concentrations as low as 0.05 ppm TOC.

The analysis of concentrations of at least 100 ppm TOC can be performed by increasing the persulfate concentration. For example, accurate data are obtained for KHP, pyridine, methanol and acetic acid over the range of 1 to 100 ppm TOC by using a persulfate concentration of 0.15 M (Figure 18).

COD Analyses. The TOC analyses of the synthetic samples serve to show that the oxidation of the organic solutes in the Breadboard Analyzer is quantitative. The COD analyses determine the quantity of persulfate required for the oxidations. During the analyses of the individual organic solutes it was found that less

TABLE 4 DEMONSTRATION OF EFFECTIVENESS OF CHLORIDE INTERFERENCE ELIMINATION

KHP Sample	Cl ⁻ Concentration, ppm	TOC Concentration, ppm		COD Concentration, ppm	
		Without Hg ⁺²	Measured With Hg ⁺²	Without Hg ⁺²	Measured With Hg ⁺²
No. 1	150	38,000	10.0	424	31.3
No. 2	150	--	10.0	--	26.7
No. 3	150	--	8.0	--	27.8
No. 4	150	--	10.0	--	27.7
Average			9.5		28.4
			10.0		25.0

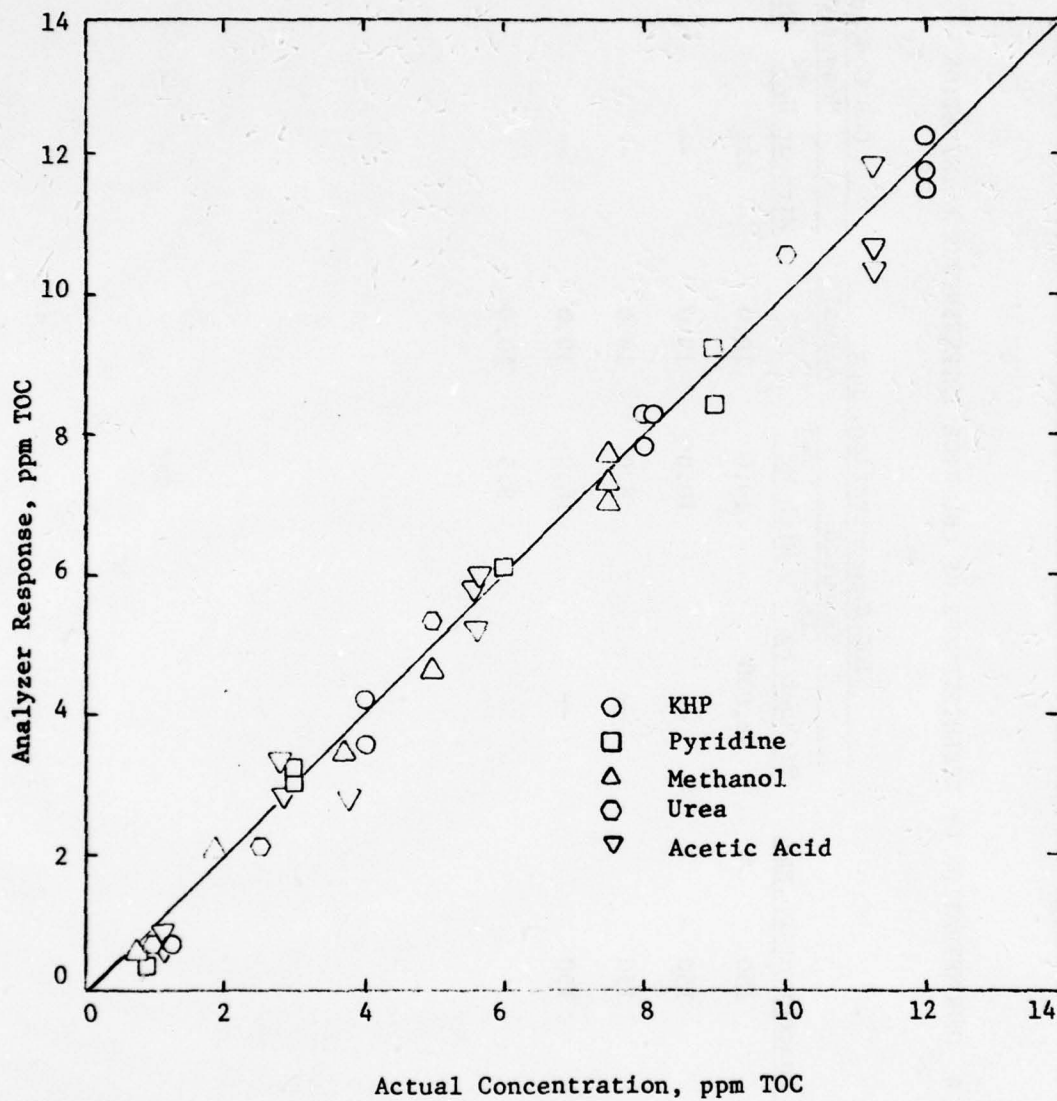

FIGURE 15 TOC RESPONSE OF BREADBOARD ANALYZER TO INDIVIDUAL ORGANIC SOLUTES

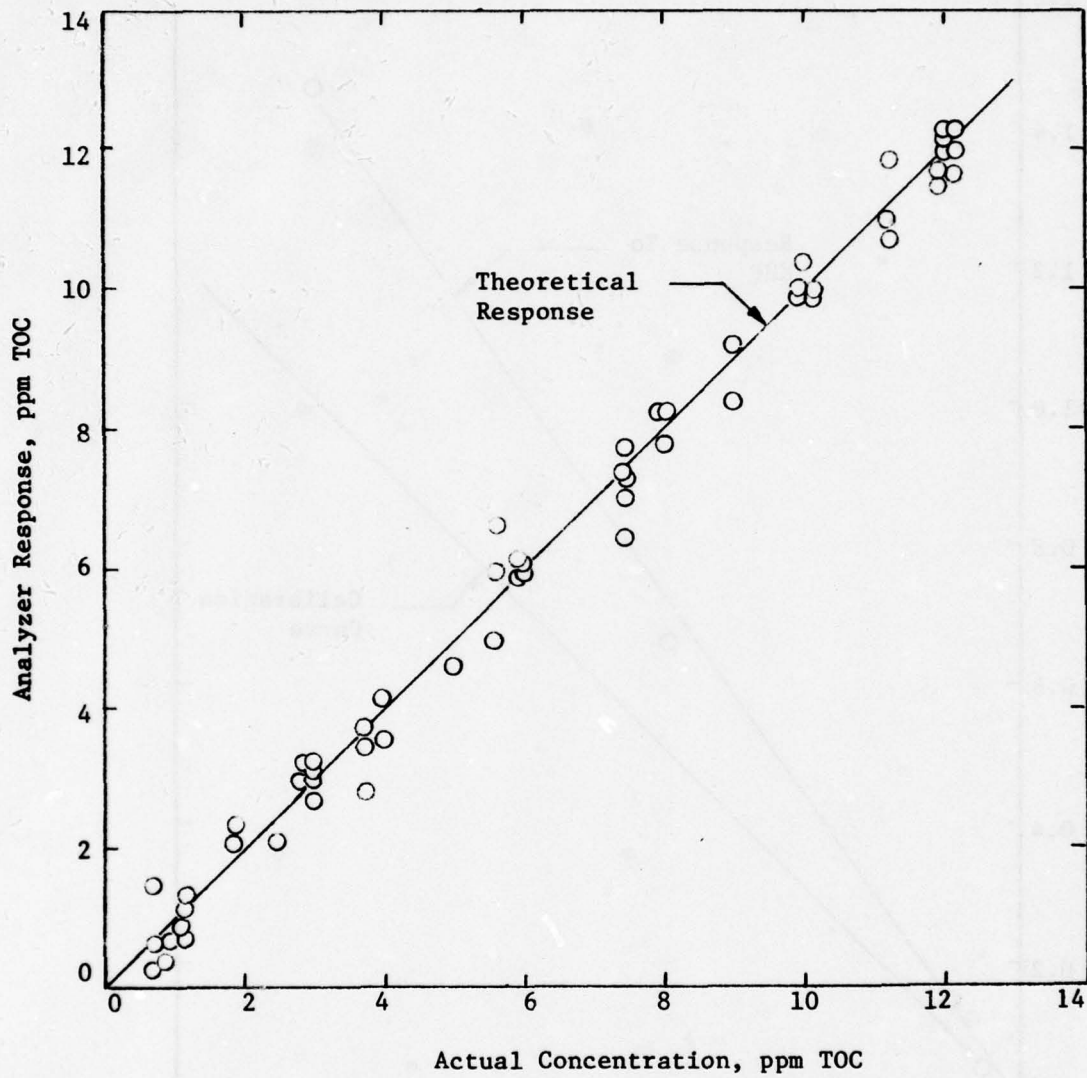

FIGURE 16 TOC RESPONSE OF BREADBOARD ANALYZER

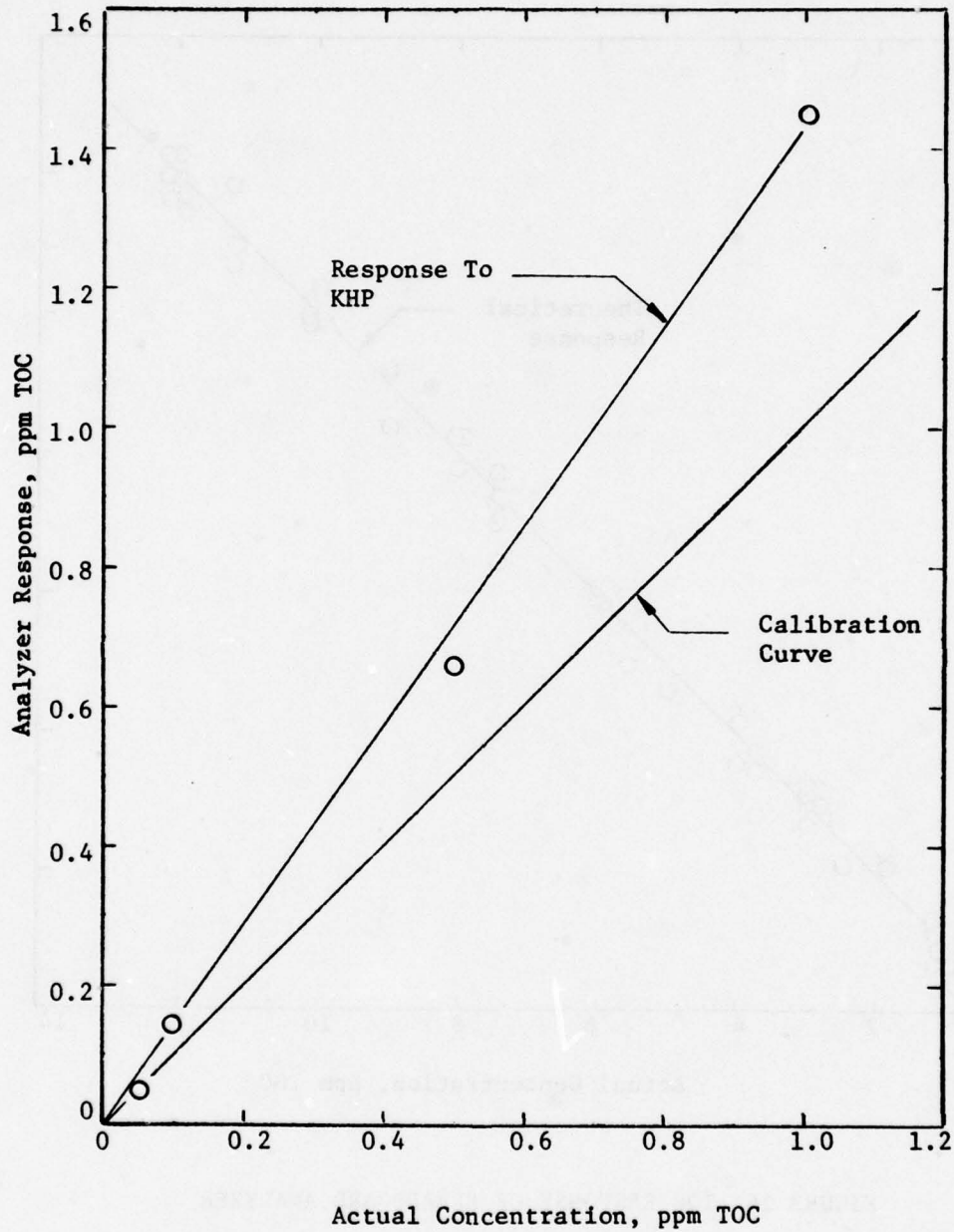

FIGURE 17 TOC RESPONSE OF BREADBOARD ANALYZER AT LOW CONCENTRATIONS

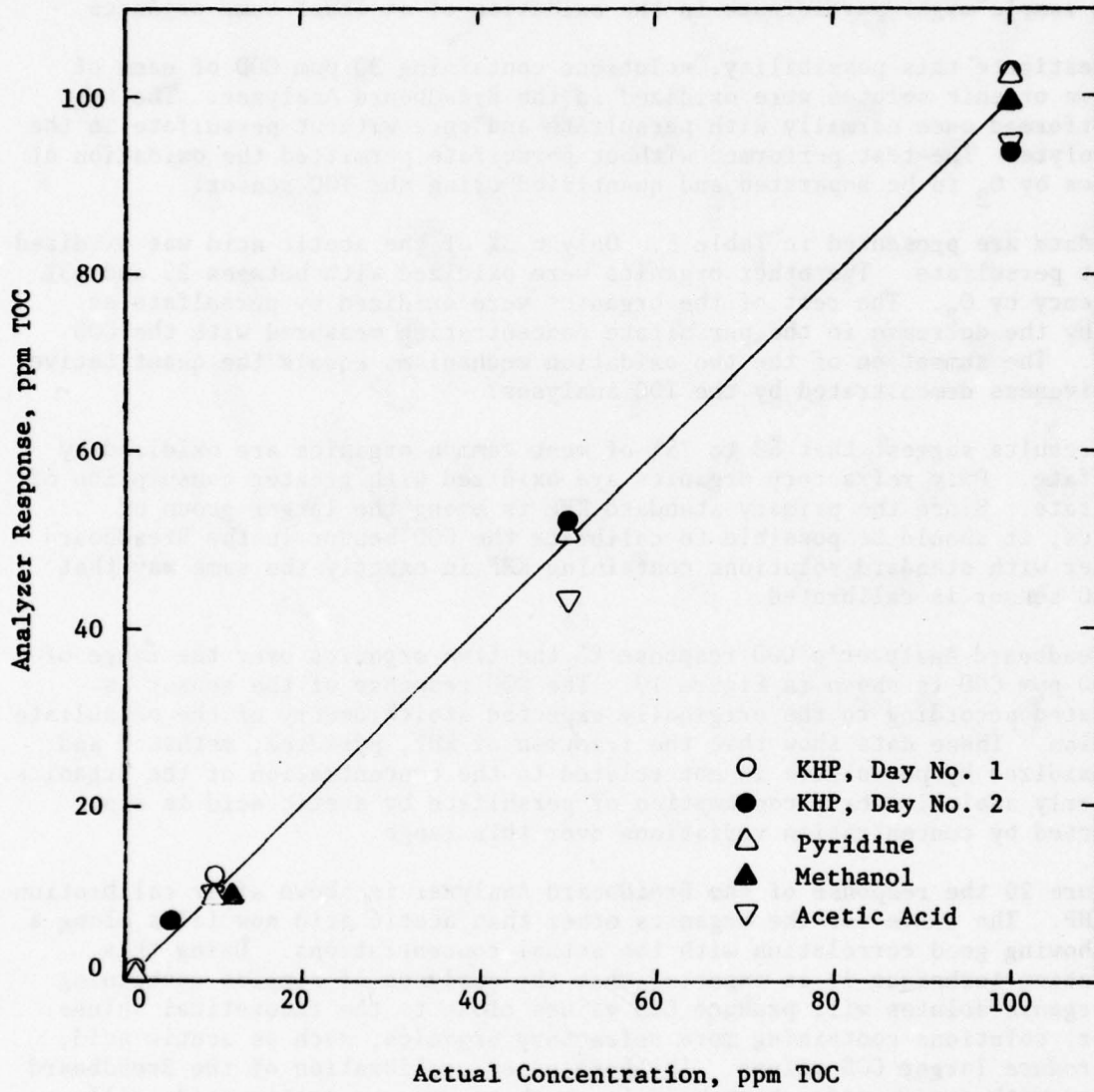

FIGURE 18 TOC RESPONSE OF BREADBOARD ANALYZER AT HIGH CONCENTRATIONS

than the expected stoichiometric amount of persulfate was required for the oxidation of all of the solutes except acetic acid. Acetic acid consumed the stoichiometric amount of persulfate. These facts imply that oxidation of the organics other than acetic acid proceeds partly through a mechanism involving an oxidizing agent other than persulfate. The UV-catalyzed oxidation of organics by O_2 has been demonstrated.⁽¹¹⁾ It seems reasonable that O_2 dissolved in the sample might participate in the oxidation of at least some organics.

To investigate this possibility, solutions containing 30 ppm COD of each of the five organic solutes were oxidized in the Breadboard Analyzer. The test was performed once normally with persulfate and once without persulfate in the electrolyte. The test performed without persulfate permitted the oxidation of organics by O_2 to be separated and quantified using the TOC sensor.

These data are presented in Table 5. Only 6.3% of the acetic acid was oxidized without persulfate. The other organics were oxidized with between 25 and 43% efficiency by O_2 . The rest of the organics were oxidized by persulfate as shown by the decrease in the persulfate concentration measured with the COD sensor. The summation of the two oxidation mechanisms equals the quantitative effectiveness demonstrated by the TOC analyses.

These results suggest that 63 to 75% of most common organics are oxidized by persulfate. Only refractory organics are oxidized with greater consumption of persulfate. Since the primary standard KHP is among the larger group of organics, it should be possible to calibrate the COD sensor in the Breadboard Analyzer with standard solutions containing KHP in exactly the same way that the TOC sensor is calibrated.

The Breadboard Analyzer's COD response to the five organics over the range of 3 to 30 ppm COD is shown in Figure 19. The COD response of the sensor is calculated according to the originally expected stoichiometry of the persulfate oxidation. These data show that the fraction of KHP, pyridine, methanol and urea oxidized by persulfate is not related to the concentration of the organics. The nearly stoichiometric consumption of persulfate by acetic acid is also unaffected by concentration variations over this range.

In Figure 20 the response of the Breadboard Analyzer is shown after calibration with KHP. The curve for the organics other than acetic acid now falls along a line showing good correlation with the actual concentrations. Using this calibration technique it is expected that the analyses of samples containing most organic solutes will produce COD values close to the theoretical values. However, solutions containing more refractory organics, such as acetic acid, will produce larger COD values. In those cases, calibration of the Breadboard Analyzer with a more refractory organic, such as urea or acetic acid, will produce closer agreement with the theoretical values.

For subsequent analyses of real samples, the TOC and COD sensors were calibrated with KHP.

TABLE 5 COMPARISONS OF ORGANIC OXIDATIONS WITH AND WITHOUT PERSULFATE

<u>Organic Solute</u>	<u>Percent Oxidation</u>		<u>Total</u>
	<u>UV and Persulfate (a)</u>	<u>UV Only (b)</u>	
KHP	64.8	43.3	108.1
Methanol	65.8	41.0	106.8
Pyridine	62.8 (c)	33.3	96.2
Urea	75.0	25.0	100.0
Acetic Acid	96.0	6.3	102.3

(a) Based on COD Sensor Response

(b) Based on TOC Sensor Response

(c) Assuming Nitrogen Oxidation Product is NH_4^+

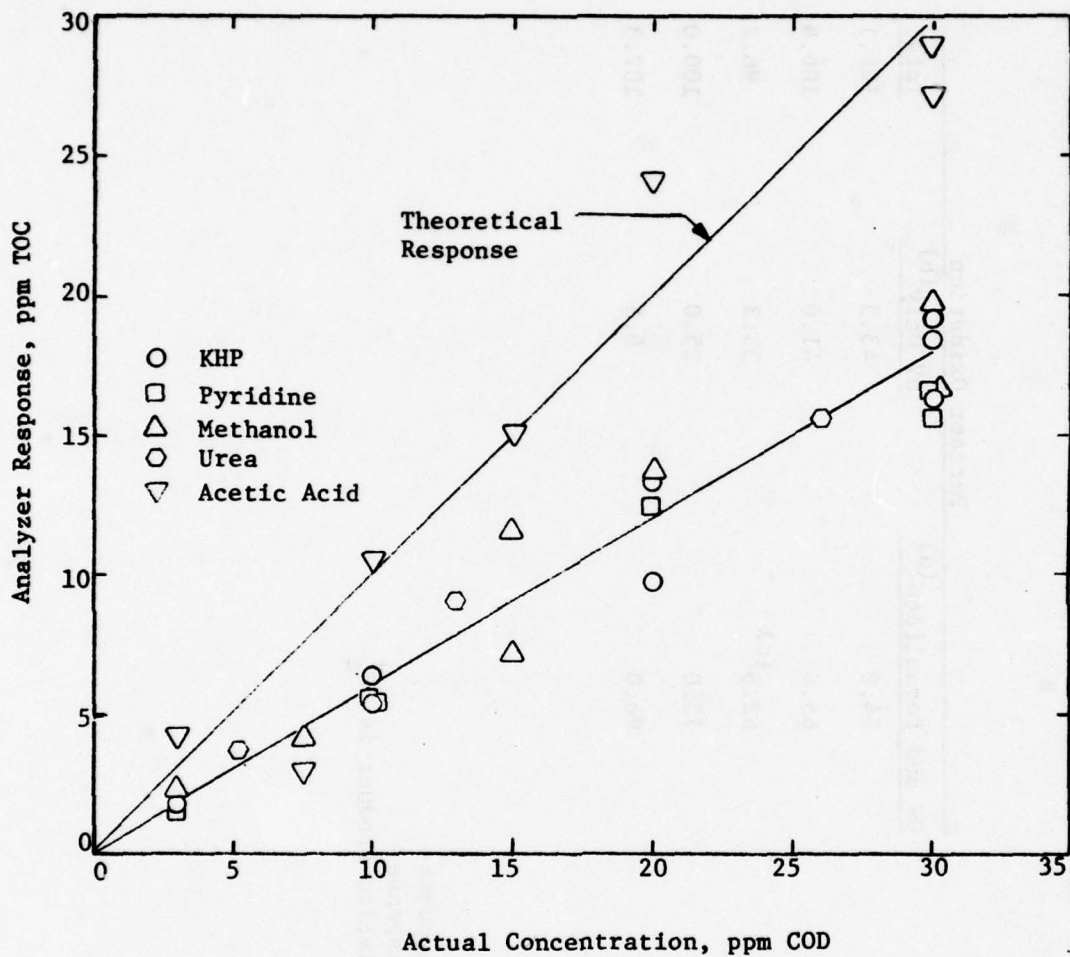

FIGURE 19 COD RESPONSE OF BREADBOARD ANALYZER BEFORE CALIBRATION

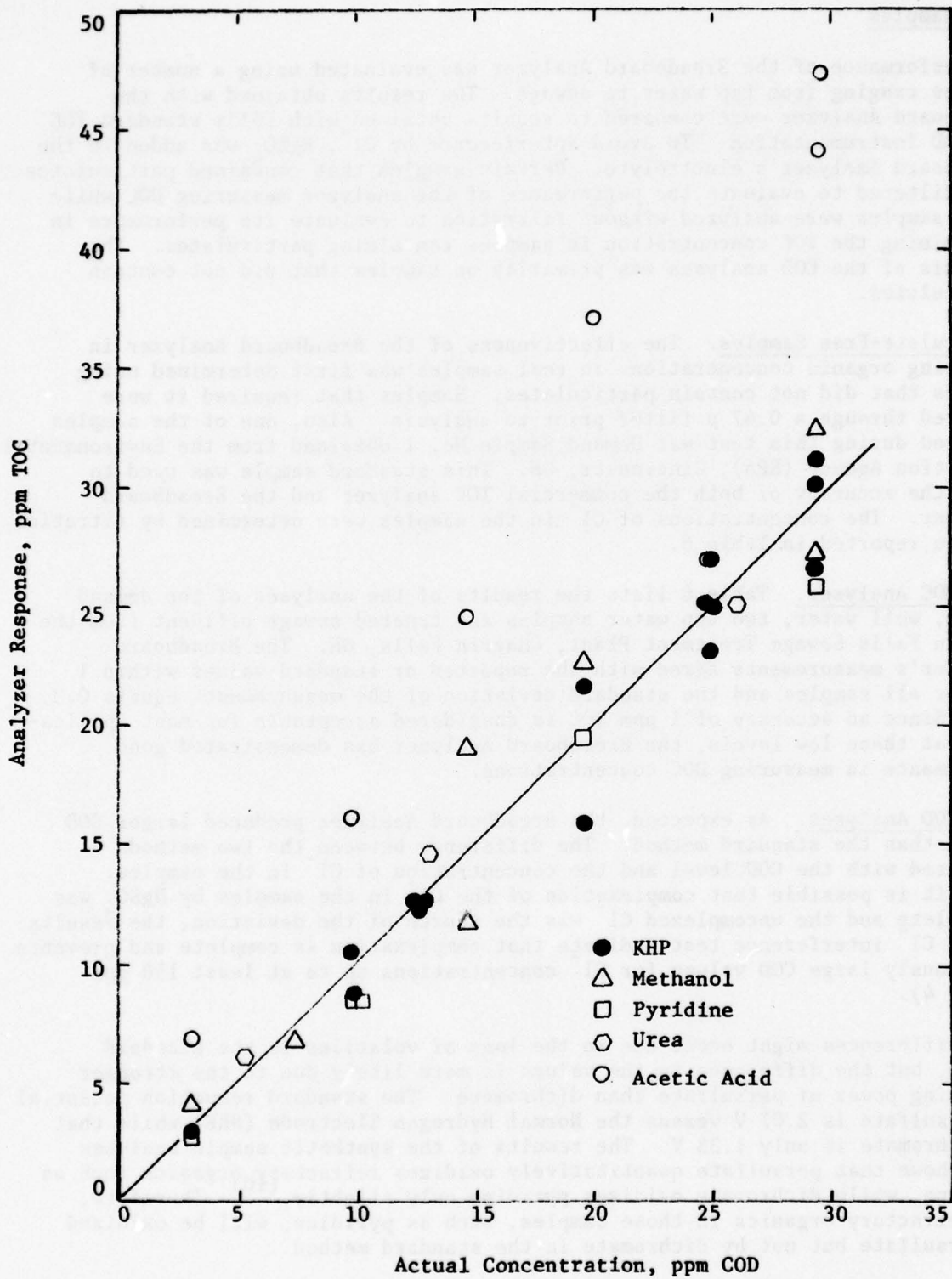

FIGURE 20 COD RESPONSE OF BREADBOARD ANALYZER AFTER CALIBRATION

Real Samples

The performance of the Breadboard Analyzer was evaluated using a number of samples ranging from tap water to sewage. The results obtained with the Breadboard Analyzer were compared to results obtained with LSI's standard TOC and COD instrumentation. To avoid interference by Cl^- , HgSO_4 was added to the Breadboard Analyzer's electrolyte. Certain samples that contained particulates were filtered to evaluate the performance of the analyzer measuring DOC while other samples were analyzed without filtration to evaluate its performance in determining the TOC concentration in samples containing particulates. The emphasis of the COD analyses was primarily on samples that did not contain particulates.

Particulate-Free Samples. The effectiveness of the Breadboard Analyzer in measuring organic concentrations in real samples was first determined using samples that did not contain particulates. Samples that required it were filtered through a 0.47μ filter prior to analysis. Also, one of the samples analyzed during this test was Demand Sample No. 1 obtained from the Environmental Protection Agency (EPA), Cincinnati, OH. This standard sample was used to check the accuracy of both the commercial TOC analyzer and the Breadboard Analyzer. The concentrations of Cl^- in the samples were determined by titration and are reported in Table 6.

DOC Analyses. Table 6 lists the results of the analyses of the demand sample, well water, two tap water samples and treated sewage effluent from the Chagrin Falls Sewage Treatment Plant, Chagrin Falls, OH. The Breadboard Analyzer's measurements agree with the reported or standard values within 1 ppm for all samples and the standard deviation of the measurements equals 0.3 ppm. Since an accuracy of 1 ppm DOC is considered acceptable for most applications at these low levels, the Breadboard Analyzer has demonstrated good performance in measuring DOC concentrations.

COD Analyses. As expected, the Breadboard Analyzer produced larger COD values than the standard method. The difference between the two methods increased with the COD level and the concentration of Cl^- in the samples. While it is possible that complexation of the Cl^- in the samples by HgSO_4 was incomplete and the uncomplexed Cl^- was the source of the deviation, the results of the Cl^- interference test indicate that complexation is complete and prevents erroneously large COD values for Cl^- concentrations up to at least 150 ppm (Table 4).

Some differences might occur due to the loss of volatiles in the standard method, but the difference in the values is more likely due to the stronger oxidizing power of persulfate than dichromate. The standard reduction potential of persulfate is 2.07 V versus the Normal Hydrogen Electrode (NHE) while that of dichromate is only 1.33 V. The results of the synthetic sample analyses have shown that persulfate quantitatively oxidizes refractory organics such as pyridine, while dichromate oxidizes pyridine only slightly. (10) Therefore, any refractory organics in those samples, such as pyridine, will be oxidized by persulfate but not by dichromate in the standard method.

TABLE 6 RESULTS OF PARTICULATE-FREE SAMPLE ANALYSES

Sample	Cl ⁻ Concentration, ppm		TOC Concentration, ppm		COD Concentration, ppm	
	Analyzer	Standard	Analyzer	Standard	Analyzer	Standard
Demand Sample No. 1: (a)						
1st Analysis	0	5.8	6.0	6.1	16.2	15.4
2nd Analysis	0	--	6.4	6.1	18.9	15.4
3rd Analysis	0	--	6.2	6.1	19.9	15.4
4th Analysis	0		6.2	6.1		15.4
Average	0		6.2	6.1	18.3	15.4
Tap Water No. 1	28	2.7	2.6	--	11.1	6.5
Tap Water No. 2	--	1.0	0.4	--	--	--
Well Water	7	3.0	3.0	--	6.4	4.1
Treated Sewage, Filtered	116	4.5	4.3	--	17.5	11.2

(a) From EPA, Cincinnati, OH

The calibration of the COD sensor in the Breadboard Analyzer was performed using standard KHP solutions. Since KHP is not a refractory compound, the calibration would not be accurate for samples having substantial amounts of refractories. Instead, a more refractory standard may be required, or the analyzer may in the future be calibrated by an initial correlation to the standard method. For example, if a correction factor of 11.2/17.5 (based on the measured values obtained with the Breadboard Analyzer and the standard method for the treated sewage sample) is applied to the results of the analyzer's COD measurements, the values equal 4.1 ppm for the well water and 7.1 ppm for the tap water. These values are in almost exact agreement with the results of the standard method. Of course, more analyses are required to fully evaluate the correlation between the persulfate-based COD measurements and the standard method.

Particulate-Containing Samples. Large numbers of environmentally important wastewaters exist that contain significant quantities of POC. Therefore, the evaluation of the Breadboard Analyzer included a test of the performance of the analyzer using samples that contain particulates.

During the early stages of the Breadboard Analyzer development it was considered possible that POC would not be completely oxidized by persulfate. This was based on two considerations. First, the presence of particulates in the sample was thought to inhibit the UV catalysis of the persulfate oxidation. However, this is not the case as shown by the inorganic particulate interference test (Table 2).

The second consideration was the assumption that carbonaceous material entrapped in particulates would be more difficult to oxidize than dissolved organics. Because of this possibility, techniques of oxidizing POC or breaking up particulates to free the organic material were evaluated for use in place of the persulfate oxidation, or as an accessory with the persulfate oxidation when POC analyses were required.

The primary criterion by which these techniques were judged is compatibility with the Electrochemical TOC/COD Analyzer. That is, they have to be compatible with continuous, automated, on-line operation. They also must be operated without expendables.

Candidate techniques were identified by a review of reported TOC and POC analysis techniques. These are summarized in Table 7. The measurement of POC is approached by these techniques in different ways. Some methods involve the measurement of the total concentration of POC and DOC in a single step. Other methods determine POC by difference by first measuring TOC and, in a separate step, measuring DOC after filtration. Other techniques involve the separate determination of POC by filtration and analysis of the solid particulates.

Various analytical techniques and instrumentation have been used for these analyses. The determination of TOC has been reported using the pyrolysis technique used by Life Systems as its standard TOC procedure. (4,12) The use of other commercial TOC analyzers have been reported. (13-15) Elemental carbon analyzers and pyrolysis equipment have also been used. (23,24) The analysis of POC by oxidation with dichromate and persulfate has been reported. (17-23)

TABLE 7 DOCUMENTED METHODS OF POC ANALYSIS

<u>Methods</u>	<u>References</u>
1. POC Plus DOC by Reductive Pyrolysis	4,12
2. POC Plus DOC by Pyrolysis	13,14,15
3. POC by Combustion	16
4. POC by Dichromate Oxidation	17,18,19,20
5. POC by Acid Persulfate Oxidation	21,22,23
6. POC by Difference, Elemental Analyzer	23,24
7. POC by Difference, Pyrolysis	25

<u>Related Methods</u>	
1. Organic Carbon from Airborne Particulates by Extraction, Reductive Pyrolysis	26
2. P in Particulates by Persulfate Oxidation	27,28
3. As in Particulates by Persulfate Oxidation	29

Also, in related procedures reported in the literature, phosphorus (P) and arsenic (As) have been determined in particulate samples through the oxidation by persulfate of the particulate matrix. (27-29)

These reports indicate that persulfate oxidation may be effective in destroying the particulate matrix and oxidizing organic compounds entrapped in or adsorbed on the particulates. Since it has been established that particulates in the sample do not significantly reduce the efficiency of organic oxidations in the Breadboard Analyzer, it was concluded that the baseline conditions used in the analyzer would be evaluated for the analysis of samples containing POC. Alternatives were considered for use as a backup in case the persulfate oxidation was ineffective. The pyrolysis and combustion techniques listed in Table 7 did not meet the criterion of ready adaptation to the analyzer. These techniques would require complex and expensive equipment since they involve gas phase reactions which cannot be easily interfaced with the liquid system used in the Breadboard Analyzer. Therefore, for the backup approach a unique alternative was considered. This was the use of ultrasonic sample digestion prior to the analysis. It is known that ultrasonics can be used to break up particulate material and it was considered likely that the digestion would expose the organics contained within the particulates for oxidation by persulfate.

Although this approach was maintained as a backup method, further evaluations of the technique showed that ultrasonic digestion generates considerable quantities of heat. Heating of the sample solution during digestion might result in the loss of volatile organics from the sample, thereby producing low TOC values. Therefore, the use of ultrasonics for particulate digestion was considered to be a much less desirable approach than internal, complete oxidation of the particulates by persulfate within the analyzer. In addition to the complexities resulting from heating by the ultrasonic pretreatment, the ultrasonic equipment is relatively expensive and would have significantly increased the cost of an end-item analyzer which incorporated ultrasonic pretreatment.

TOC Analyses. Five samples containing POC and DOC were analyzed. These results are listed in Table 8. Water from the Chagrin River plus treated and raw sewage from the Chagrin Falls Sewage Treatment Plant were analyzed by the Breadboard Analyzer and LSI's commercial TOC analyzer.

The results obtained with the Breadboard Analyzer and the commercial instrument agree to within 0.2 ppm for the river water and the treated sewage samples. Replicates of the third treated sewage sample were run during separate tests and are shown. The standard deviation of these measurements is 1.2 ppm TOC. The standard deviation for all treated sewage samples and the river water is 0.9 ppm TOC.

The raw sewage sample resulted in the largest divergence between the values obtained with the two analyzers. The Breadboard Analyzer reported 31.1 ppm TOC while the commercial instrument reported 27.3 ppm. On the basis of the standard additions test (Table 9) it is concluded that the Breadboard Analyzer reported the more accurate value. The standard additions test was performed by adding quantities of KHP to some of the particulate-containing samples in order to test the oxidation efficiency of the Breadboard Analyzer. The concen-

TABLE 8 RESULTS OF TOC ANALYSES OF PARTICULATE-CONTAINING SAMPLES

Sample	TOC Concentration, ppm		TOC Recovery, %
	Breadboard Analyzer	Standard	
Chagrin River Water	5.0	4.8	104
Treated Sewage No. 1	9.8	9.8	100
Treated Sewage No. 2	9.5	9.4	101
Treated Sewage No. 3:			
1st Analysis	7.0	7.6	
2nd Analysis	8.0	--	
3rd Analysis	8.6	--	
4th Analysis	5.9	--	
Average	7.4		97
Raw Sewage	31.1	27.3	114
			Average 103

TABLE 9 RESULTS OF STANDARD ADDITIONS TOC STUDY

Sample	Initial TOC, ppm	TOC Added, (a) ppm	TOC Recovered, ppm	Recovery, %
Chagrin River Water	5.0	47.6	42.8	90
Treated Sewage No. 1	9.5	9.1	9.3	102
Treated Sewage No. 2	8.3	10.0	9.7	97
Raw Sewage	31.1	47.6	47.4	100
			Average	97

(a) As KHP

tration of KHP added to the raw sewage sample equaled 47.6 ppm TOC, so that after the addition the TOC concentration was 78.7 ppm. The analysis of this sample produced a value of 78.5 ppm which represents the 31.1 ppm TOC initially in the sample plus recovery of 47.4 ppm of the added KHP. Therefore, the Breadboard Analyzer demonstrated 100% recovery of added TOC. Recovery of TOC added to the other samples ranged between 90 and 102%, with the average equalling 97%.

The efficiency of the organic oxidation was additionally tested by successively diluting samples to one-half and one-quarter their initial concentrations. For treated and raw sewage samples the test indicated that organics underwent complete oxidation (Table 10).

COD Analyses. The analysis of particulate-containing samples originally was scheduled to involve only TOC measurements. However, unfiltered treated and raw sewage samples were analyzed by the Breadboard Analyzer and standard methods to provide a comparison of the COD data obtained by the two methods for samples that contain particulates.

These data are shown in Table 11. For the treated sewage samples the Breadboard Analyzer produced larger values than the standard technique, as expected on the basis of the analysis of particulate-free samples. However, the values agree to within 1% for the raw sewage sample. As with the particulate-free samples, these data indicate reasonable agreement between the two COD methods. However, more extensive tests are required to fully assess the degree to which the two COD methods correlate.

CONCLUSIONS

The objectives of the Breadboard Electrochemical TOC/COD Analyzer development have been successfully achieved. The measurement of COD using the persulfate oxidation technique has been demonstrated for the first time. Various synthetic and real samples, ranging from tap water to raw sewage, have been analyzed. Results obtained with the Breadboard Analyzer compare favorably with data obtained using standard methods. Total organic carbon values agree extremely well, while COD values are somewhat higher than those obtained with the standard reflux COD method. This is probably because persulfate is a stronger oxidizing agent than dichromate used in the standard method and more completely oxidizes organics. It has been shown during the test program that as the refractory nature of organic solutes increases, the apparent COD concentration of the solution containing those solutes increases, as measured with the Breadboard Analyzer. Therefore, the correlation of COD values obtained with the analyzer and the standard method can be improved by using a more refractory organic for calibration of the COD sensor. The sensor was calibrated with KHP during this test program. In most cases a closer agreement between the COD measurements made with the analyzer and the standard method would have resulted had urea or acetic acid been used to calibrate the analyzer.

The test program has also demonstrated that the Breadboard Analyzer is capable of detecting as little as 0.05 ppm TOC and 3 ppm COD or less. Concentrations as high as 100 ppm TOC and 166.8 ppm COD have been measured. The measurement of higher concentrations is possible by using larger persulfate concentrations

TABLE 10 RESULTS OF STANDARD DILUTION TOC STUDY

<u>Sample</u>	<u>TOC Concentration, ppm</u>		<u>Calculated</u>
	<u>Breadboard Analyzer</u>	<u>Standard</u>	
Treated Sewage:			
Initial Concentration	7.4	7.6	7.6
1:1 Dilution	3.4	3.4	3.8
1:3 Dilution	1.7	1.7	1.9
Raw Sewage:			
Initial Concentration	24.2	--	24.2
1:1 Dilution	12.3	--	12.1
1:3 Dilution	5.9	--	6.0

TABLE 11 RESULTS OF COD ANALYSES OF PARTICULATE-CONTAINING SAMPLES

<u>Sample</u>	<u>Breadboard Analyzer</u>	<u>COD Concentration, ppm</u>	<u>Standard</u>	<u>Recovery, %</u>
Treated Sewage No. 1	20.4	16.8		121
Treated Sewage No. 2	30.4	23.0		132
Raw Sewage	166.8	164.5		101
			Average	118

and possibly a longer residence time in the UV reactor. The oxidation of organics in the Breadboard Analyzer has been shown to be quantitative even for relatively refractory organics such as acetic acid and urea.

The only significant interference encountered during the test program was Cl^- . This effect is similar to that experienced in the standard COD method when Cl^- is present. Large COD values are obtained with the Breadboard Analyzer when Cl^- is contained in samples since persulfate is consumed in the oxidation of Cl^- . The TOC sensor is affected by the resulting Cl_2 . However, the interference is eliminated by adding HgSO_4 to the electrolyte. This procedure is similar to that used in the standard method. However, future implementation of the electrolyte recycle loop in advanced Electrochemical TOC/COD Analyzers must consider the impact on the analyzer of the presence of HgSO_4 and complexed and uncomplexed Cl^- in the recycle loop.

Some areas for improvement in the design of future Electrochemical TOC/COD Analyzers have been noted. The coulometric COD sensor used during this program requires 45 to 60 minutes per analysis. Frequent standards must be analyzed to obtain accurate results. Although the time required for the COD measurement is less than the two hours required by the standard method, the goal of future development activities is a COD sensor that will provide COD data with a response time of 5 to 15 minutes.

In the Breadboard Analyzer considerable operator labor was required in the preparation of calibration curves and calculation of TOC and COD concentrations of unknown samples from the millivolt and coulomb outputs of the TOC and COD sensor instrumentation. To reduce this effort future analyzers should include the feature of direct readout in TOC and COD units. Eventually an automated calibration system may be incorporated to further reduce operator labor.

The Breadboard Analyzer also demonstrated the need for daily preparation of persulfate solutions when in situ generation of persulfate is not utilized in the analyzer. Daily preparation of the solution is necessary because persulfate is unstable and decomposes in a matter of hours. A constant concentration of persulfate is required for precise COD measurements. To achieve the precise measurements with less labor, future analyzers should incorporate the persulfate generation cell for in situ generation of the reagent even if the electrolyte recycle loop is not employed.

In summary, the Breadboard Analyzer has been useful in demonstrating the practicality of the Electrochemical TOC/COD Analyzer concept. It has permitted the optimum oxidation conditions in the analyzer to be defined. It has been useful in investigating potential problems and the Breadboard Analyzer has demonstrated, for selected samples, the kind of analytical performance that may be expected from future advanced Electrochemical TOC/COD Analyzers.

RECOMMENDATIONS

The Breadboard Electrochemical TOC/COD Analyzer has demonstrated that the persulfate oxidation technique is a practical method of monitoring TOC and COD concentrations. The measurements can be made automatically by integrating components such as the persulfate generation cell and the inorganic carbon

stripper with advanced versions of the UV reactor and sensors already tested. The end item Electrochemical TOC/COD Analyzer will utilize all of these components, but to insure reliable and accurate operation the components will be developed to a more advanced level than those used in the Breadboard Analyzer. In the case of certain components such as the COD sensor, a reasonably extensive development effort remains to be performed before the advanced components will be achieved. For this reason efforts are already underway to evaluate advanced concepts for the COD sensor.

It is recommended that an analyzer be developed that is intermediate between the Breadboard Analyzer and the end item. With this Advanced Breadboard the concepts to be employed in the end item components can be tested and upgraded, if necessary, before they are incorporated into the end item analyzer.

The Advanced Breadboard will also be useful in on-site tests that will challenge the ability of the analyzer to operate in the actual environments in which the end item analyzer will be used. For example, extreme temperature variations, vibrations or airborne chemicals or particulates might affect the analyzer's performance. Data and observations from the on-site tests will be used to modify the design concepts used in the Advanced Breadboard Analyzer. These modifications will result in satisfaction of the application requirements at the end item analyzer level.

It is recommended that the Advanced Breadboard Analyzer be designed to include all analyzer components for automated operation (with the exception of the electrolyte recycle loop which can be added later). It will also include direct readout of TOC and COD concentrations for cost-effective data reduction and interpretation. An advanced breadboard persulfate generation cell will be developed to reduce operator labor involved in reagent preparation and to permit long-term operation with constant concentrations of persulfate. The Advanced Breadboard will then be tested to check out the performance of these components.

After completion of the checkout and verification tests, the design of the Advanced Breadboard will be upgraded to eliminate any problem areas identified during the testing program. It is then recommended that several units of the upgraded Advanced Breadboard be prepared for on-site tests in a variety of applications. The results of these on-site tests, along with the laboratory tests of the Advanced Breadboard performed at LSI, will lead to the development of end item analyzers uniquely suited to field and in-plant process monitoring and control applications.

REFERENCES

1. Davenport, R. J. and Wynveen, R. A., "Development of Organic Solute and Total Organic Carbon Monitors," Annual Report, Contract DAMD17-75-C-5070, ER-285-3, Life Systems, Inc., Cleveland, OH, June, 1976.
2. Davenport, R. J. and Wynveen, R. A., "Fundamental Studies for Development of Electrochemical COD and TOC Analyzers," Annual Report, Contract DAMD17-76-C-6077, ER-310-4, Life Systems, Inc., Cleveland, OH, September, 1977.
3. Walsh, T. J. and Leovic, W. J., Chem. Eng. Progr., 61, 76, 1965.
4. McQuaker, N. R. and Fung, T., Anal. Chem., 47, 1435, 1975.
5. U. S. Environmental Protection Agency, "Methods for Chemical Analysis of Water and Wastes," Office of Technology Transfer, Cincinnati, OH, 1974.
6. M. H. Adelman, 18th Pittsburgh Conference on Analytical Chemical and Applied Spectroscopy, Pittsburgh, PA, March, 1967.
7. Edwards, J. O., Ed., "Peroxide Reaction Mechanisms," Interscience Publishers, New York, 1962.
8. "Laboratory Procedures for Wastewater Treatment Plant Operators," New York State Department of Health, Albany, NY.
9. Gehm, H. W. and Bregman, J. I., Eds., "Handbook for Water Resources and Pollution Control," Van Nostrand Reinhold Co., New York, 1976.
10. American Public Health Association, Inc., "Standard Methods for the Examination of Water and Wastewaters," 14th Edition, Washington, DC, 1975.
11. Goulden, P. D. and Brooksbank, P., Anal. Chem. 47, 1943, 1975.
12. Takahashi, Y., Moore, R. T. and Joyce, R. J., Am. Lab., 4, 31, 1972.
13. Van Steenderen, R. A., Water SA, 2, 156, 1976.
14. Van Hall, C. E. and Stenger, V. A., Anal. Chem., 39, 503, 1967.
15. Merz, W., Am. Lab., 8, 29, 1976.
16. Menzel, D. W. and Vaccaro, R. F., Limnol. Oceanog., 9, 138, 1964.
17. Menzel, D. W. and Ryther, J. H., Limnol. Oceanog., 9, 179, 1964.
18. Krogh, A. and Keys, A., Biol. Bull., 67, 132, 1934.
19. Kay, H., Kiel. Meeresforsch., 10, 26, 1954.

20. Duursma, E. K., Neth. J. Sea Research, 1, 1, 1961.
21. Wilson, R. F., Limnol. Oceanog., 6, 259, 1961.
22. Brooks, J. M., M.S. Thesis, Texas A&M University, 1970.
23. Malcolm, R. L. and Leenheer, J. A., Proc. 19th Ann. Meeting of the Institute of Environ. Sciences, Anaheim, CA, April, 1973.
24. Hirota, J. and Szyper, J. P., Limnol. Oceanog, 20, 296, 1975.
25. Heistand, R. N. and Humphries, H. B., Anal. Chem., 48, 1192, 1976.
26. Grosjean, D., Anal. Chem., 47, 797, 1975.
27. Canelli, E. and Mitchell, D. G., Water Res., 9, 1093, 1975.
28. Cowen, W. F. and Lee, G. F., "Algae Nutrient Availability and Limitation in Lake Ontario During IFYGL. Part 1," Contract No. R-800537-02, EPA-600/3-76-094a, University of Texas at Dallas, Richardson, TX, October, 1976.
29. Fishman, M. and Spencer, R., Anal. Chem., 49, 1599, 1977.

DISTRIBUTION LIST

Commander US Army Medical Bioengineering Research and Development Laboratory ATTN: SGRD-UBG Fort Detrick, Frederick, MD 21701	25 copies
HQDA (SGRD-AJ) Fort Detrick Frederick, MD 21701	4 copies
Defense Documentation Center (DDC) ATTN: DDC-TCA Cameron Station Alexandria, Virginia 22314	12 copies
Dean School of Medicine Uniformed Services University of the Health Sciences Office of the Secretary of Defense 6917 Arlington Road Bethesda, MD 20014	1 copy
Superintendent Academy of Health Sciences, US Army ATTN: AHS-COM Fort Sam Houston, TX 78234	1 copy