

AD-A062 018

ARMY COMMUNICATIONS-ELECTRONICS ENGINEERING INSTALLAT--ETC F/G 17/2
DIGITAL TRANSMISSION EVALUATION PROJECT UNIVERSAL LOOP MULTIPLE--ETC(U)
NOV 78 J E HAMANT, O P CONNELL, H S WALCZYK
CCC-CED-78-DTEP-017

UNCLASSIFIED

NL

1 OF 2
AD A062 018

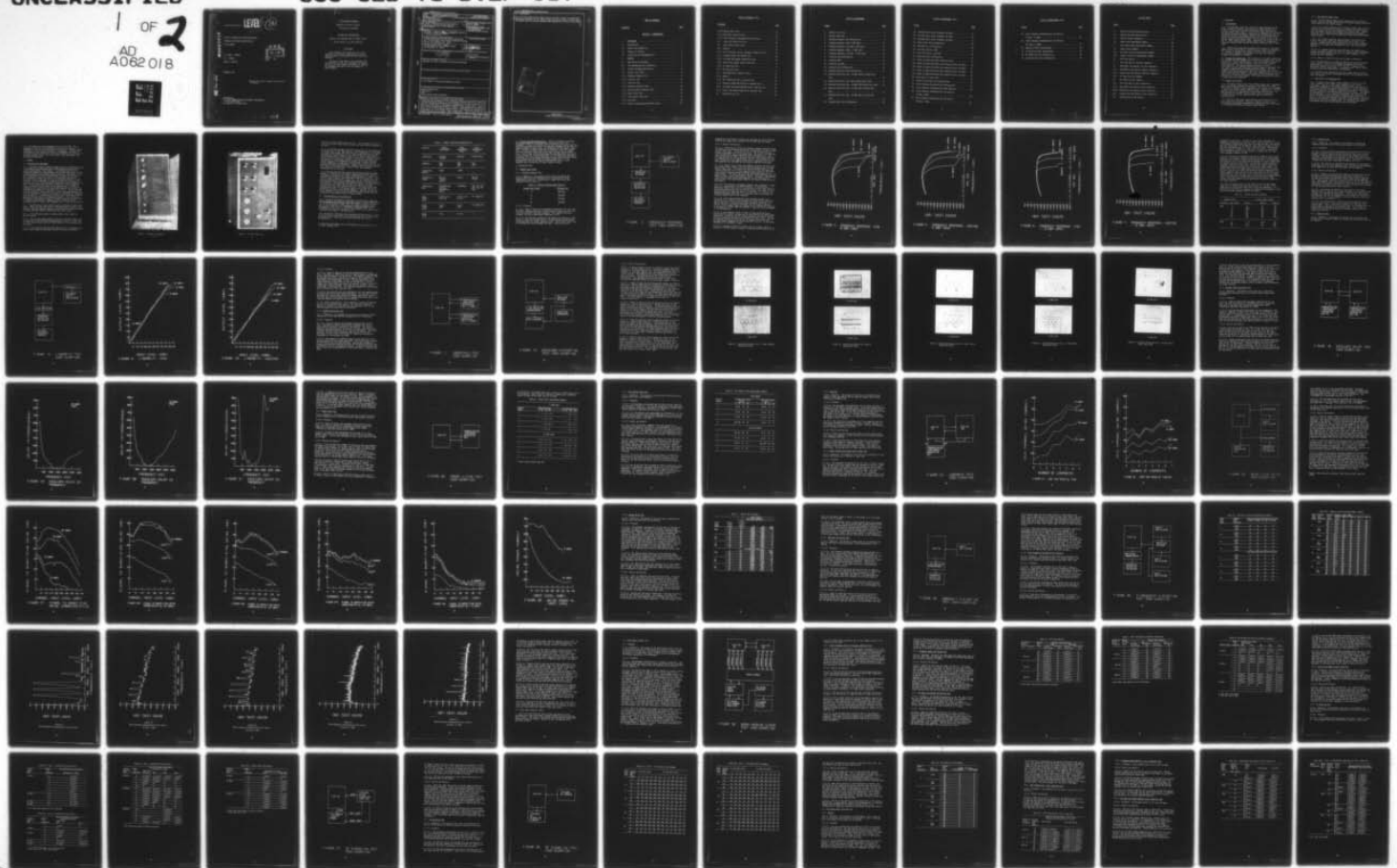

CCC-CED-78-DTEP-017

LEVEL III

19
B.S.

A046962

ADA062018

DIGITAL TRANSMISSION EVALUATION PROJECT
UNIVERSAL LOOP MULTIPLEXER ULM-101
FINAL REPORT

CPT JAMES E. HAMANT
O. P. CONNELL
HENRY S. WALCZYK

DDC
RECEIVED
DEC 11 1978
F

NOVEMBER 1978

Approved for public release; distribution unlimited

DDC FILE COPY

HEADQUARTERS
U.S. ARMY COMMUNICATIONS-ELECTRONICS ENGINEERING
INSTALLATION AGENCY
Fort Huachuca, Arizona 85613

78 12 07 03 7

DISTRIBUTION STATEMENT

Approved for public release

Distribution unlimited

DISPOSITION INSTRUCTIONS

Destroy this document when no longer needed

Do not return it to the originator

DISCLAIMER

The findings of this report are not to be construed as an official Department of the Army position unless so designated by other authorized documents.

The use of trade names in this document does not constitute an official endorsement or approval of the use of such commercial hardware or software. This document may not be cited for purpose of advertisement.

NOV 10 1981

DDC LIFE COBA

REPORT DOCUMENTATION PAGE		READ INSTRUCTIONS BEFORE COMPLETING FORM
1. REPORT NUMBER CCC-CED-78-DTEP-017	2. GOVT ACCESSION NO.	3. RECIPIENT'S CATALOG NUMBER
4. TITLE (and Subtitle) Digital Transmission Evaluation Project Universal Loop Multiplexer ULM-101. Final Report	5. TYPE OF REPORT & PERIOD COVERED FINAL REPORT, Feb 77 to Jul 78	6. PERFORMING ORG. REPORT NUMBER CCC-CED-DTEP-017
7. AUTHOR(s) CPT James E. Hamant, O. P. Connell Mr. Henry S. Walczyk USAEPG	8. CONTRACT OR GRANT NUMBER(s)	
9. PERFORMING ORGANIZATION NAME AND ADDRESS US Army Communications-Electronics Engineering Installation Agency and US Army Electronic Proving Ground, Fort Huachuca, AZ 85613	10. PROGRAM ELEMENT, PROJECT, TASK AREA & WORK UNIT NUMBERS	
11. CONTROLLING OFFICE NAME AND ADDRESS US Army Communications Command, DCSOPS Fort Huachuca, AZ 85613	12. REPORT DATE November 1978	13. NUMBER OF PAGES 102
14. MONITORING AGENCY NAME & ADDRESS (if different from Controlling Office) 12 ID4p.	15. SECURITY CLASS. (of this report) Unclassified	15a. DECLASSIFICATION/DOWNGRADING SCHEDULE
16. DISTRIBUTION STATEMENT (of this Report) Approved for public release, distribution unlimited		
17. DISTRIBUTION STATEMENT (of the abstract entered in Block 20, if different from Report)		
18. SUPPLEMENTARY NOTES To be entered in Defense Documentation Center		
19. KEY WORDS (Continue on reverse side if necessary and identify by block number) Digital transmission Multiplexer CVSD Quasi-analog signal processing		
20. ABSTRACT (Continue on reverse side if necessary and identify by block number) Testing of the ULM-101, Universal Loop Multiplexer, was initiated to establish a data base and assessment of the Continuous Variable Slope Delta (CVSD) and log CVSD modulation techniques and to evaluate its ability to process signals typical of those used in the Defense Communications System (DCS). Tests of voice channel performance showed, in general, that minimum DCS standards were met at 32 or 64 kbps channel sampling rates. Performance was marginal and unacceptable at 16 and 8 kbps rates, respectively. Voice Intelligibility Test results are not yet available. DCEC is expected to publish these results. (cont'd)		

20. (continued)

Use of various quasi-analog signal sources resulted in good to unacceptable performance depending on the channel sampling rate and type of signal source. Performance was not severely degraded when operating in an error environment.

ACCESSION NO.	
NTIS	<input type="checkbox"/>
DDC	<input type="checkbox"/>
UNANNOUNCED	<input checked="" type="checkbox"/>
JUSTIFICATION	<input type="checkbox"/>
BY	
DISTRIBUTION/AVAILABILITY CODES	
Dist.	
ALL	
SPECIAL	

CONT

TABLE OF CONTENTS

<u>Paragraph</u>		<u>Page</u>
<u>SECTION 1. INTRODUCTION</u>		
1	BACKGROUND.	1
1.1	Introduction.	1
1.2	General Test Objectives	1
1.3	Summary of Findings	1
1.4	Conclusions and Recommendations	2
2	GENERAL	3
2.1	Description of Equipment.	3
2.2	Test Methodology and Limitations.	6
2.3	ULM-101 Equipment Modification.	8
3.1	Channel Level Tests	8
3.1.1	Frequency Response Test	8
3.1.2	Linearity Test.	16
3.1.3	Crosstalk Test.	16
3.1.4	Waveform Distortion Test.	20
3.1.5	Envelope Delay Distortion Test.	29
3.1.6	Phase Jitter Test	34
3.1.7	Idle Channel Noise Test	37
3.1.8	Loop Test	39
3.1.9	Signal To Quantizing Noise Ratio Test	39

TABLE OF CONTENTS (Cont)

<u>Paragraph</u>	<u>Page</u>
3.1.10 Impulse Noise Test.	51
3.1.11 Nonlinear Distortion Test	53
3.1.12 Three Frequency Intermodulation Distortion.	55
3.2 Voice Intelligibility Tests	64
3.3 Quasi-Analog Signal Tests	65
3.3.1 General	65
3.3.2 Voice Frequency Carrier Telegraph, AN/FCC-19 Test	67
3.3.3 Telephone Modem, MD-775/GCC Test.	68
3.3.4 Low Speed Data Modem, MD-674(P)/G Test.	68
3.3.5 Digital Data Modem, Lenkurt 261A Test	72
3.3.6 SF Signalling Test.	72
3.3.7 MF Signalling Test.	77
3.4 Data Modem-Error Injection Tests.	81
3.4.1 General	81
3.4.2 VFCT (AN/FCC-19)-Error Injection Test	83
3.4.3 Telephone Modem (MD-775)-Error Injection Test	84
3.4.4 Low Speed Data Modem (MD-674)-Error Injection Test. . . .	84
3.4.5 Digital Data Modem (261A)-Error Injection Test.	88
3.5 Synchronization Test.	89

LIST OF ILLUSTRATIONS

<u>Figure</u>	<u>Page</u>
1. ULM-101, Front View	4
2. ULM-101, Back View.	5
3. Frequency Response Test Configuration	9
4. Frequency Response, CVSD, 0 dBm Input	11
5. Frequency Response, Log CVSD, 0 dBm Input	12
6. Frequency Response, CVSD, -13 dBm Input	13
7. Frequency Response, Log CVSD, -13 dBm Input	14
8. Linearity Test Configuration.	17
9. Linearity CVSD.	18
10. Linearity Log CVSD.	19
11. Crosstalk Test Configuration.	21
12. Waveform Distortion Test Configuration.	22
13. Waveform Distortion Test, -10 dBm, 1800 Hz Square Wave Input	24
14. Waveform Distortion Test, 500 Hz Square Wave Input.	25
15. Waveform Distortion Test, -10 dBm, 1750 Square Wave Input	26
16. Waveform Distortion Test, -10 dBm, 500 Hz Square Wave Input	27
17. Waveform Distortion Test, -20 dBm, 900 Hz Square Wave Input	28
18. Envelope Delay Test Configuration	30

LIST OF ILLUSTRATIONS (Cont)

<u>Figure</u>	<u>Page</u>
19. Envelope Delay versus Frequency (64 kbps)	31
20. Envelope Delay versus Frequency (32 kbps)	32
21. Envelope Delay versus Frequency (16 kbps)	33
22. Phase Jitter Test Configuration	35
23. Loop Back Test Configuration.	40
24. Loop Test Results, CVSD	41
25. Loop Test Results, Log CVSD	42
26. Quantizing Noise Configuration.	43
27. Signal to Quantizing Noise Characteristics.	45
27a Signal to Quantizing Noise with Injected Errors (64 kbps) .	46
27b Signal to Quantizing Noise with Injected Errors (32 kbps) .	47
27c Signal to Quantizing Noise with Injected Errors (16 kbps) .	48
27d Signal to Quantizing Noise with Injected Errors (8 kbps) .	49
28. Noise Power vs Input Level.	50
29. Harmonic Distortion Test Configuration.	54
30. Three Frequency Distortion Test Configuration	56
31. Three Frequency Intermodulation Input Spectrum.	59
32. Three Frequency Intermodulation Test Results (8 kbps, 0 dBm)	60
33. Three Frequency Intermodulation Test Results (64 kbps, 0 dBm).	61

LIST OF ILLUSTRATIONS (Cont)

<u>Figure</u>	<u>Page</u>
34. Three Frequency Intermodulation Test Results (8 kbps, -13 dBm)	62
35. Three Frequency Intermodulation Test Results (64 kbps, -13 dBm).	63
36. AN/FCC-19 (VFCT) Configuration.	66
37. SF Signalling Test Configuration.	76
38. MF Signalling Test Configuration.	78
39. Synchronization Test Configuration.	90

LIST OF TABLES

<u>Table</u>	<u>Page</u>
I. ULM-101 Interface Characteristics.	7
II. ULM-101 Pass Band Specification.	8
III. ULM-101 Harmonic Responses	15
IV. Phase Jitter Measurement Summary	36
V. Idle Channel Noise Measurement Summary	38
VI. Impulse Noise Summary.	52
VII. Nonlinear Distortion Measurement Summary	57
VIII. Harmonic Distortion Measurement Summary.	58
IX. VFCT Test Results.	69
X. VFCT Test Results (ULM-101 loopbacks).	70
XI. MD-775/GCC Test Results (ULM-101 loopbacks).	71
XII. MD-674(P)/G Test Results (ULM-101 loopbacks)	73
XIII. Lenkurt 261A Test Results (ULM-101 loopbacks).	75
XIV. SF Signalling Test Summary	79
XV. MF Signalling Test Summary	82
XVI. VFCT Test Results (Error Injection).	83
XVII. MD-775/GCC Test Results (Error Injection).	85
XVIII. MD-674(P)/G Test Results (Error Injection)	86
XIX. Lenkurt 261A Test Results (Error Injection).	88
XX. Synchronization Test Results	92

1. BACKGROUND

1.1 Introduction

1.1.1 This document reports the results of tests performed on the General Dynamics Universal Loop Multiplexer, Model ULM-101, which utilizes a Continuously Variable Slope Delta (CVSD) technique for encoding analog input signals. The U.S. Army Communications-Electronics Engineering Installation Agency (USACEEIA) was assigned the task of evaluating the basic performance capabilities of the ULM-101 and its ability to interface analog signals typical of those in use in the Defense Communications System (DCS). The ULM-101 was tested as part of the U.S. Army Communications Command (USACC) Digital Transmission Evaluation Project (DTEP) during the period of February 1977 to July 1978.

1.1.2 USACEEIA was authorized to perform this mission by U.S. Army Communications Systems Agency (USACSA) message, CCM-SP-C, 292035Z Nov 75. Conduct of the tests was tasked to the U.S. Army Electronics Proving Ground (USAEPG), Fort Huachuca, AZ, under the technical guidance and management of USACEEIA.

1.2 General Test Objectives. The evaluation of the Model ULM-101 has been divided into four categories to establish the capabilities of the multiplexer in four different areas. The first category consists of twelve voice channel tests conducted on the unit using standard instrumentation. The second category consists of a voice intelligibility test performed with the multiplexer by personnel from the Defense Communications Engineering Center (DCEC). The third category involves the use of the ULM-101 to interface with various typical quasi-analog equipment. The final category consists of various tests which define the level of performance of the multiplexer when operating in an error environment. This report discusses the results of these four test categories.

1.3 Summary of Findings

1.3.1 The channel level tests of the ULM-101 reveal that it generally meets minimum DCA standards (as defined in DCAC 300-175-9, Table II, DCS Technical Schedule Circuit Parameters) for channel level equipment at the 32 and 64 kbps channel sampling rates, is marginal at a 16 kbps sampling rate and is unacceptable at an 8 kbps sampling rate. The ULM-101 would be unuseable at any channel rate as a medium of transmission for circuits requiring high quality transmission characteristics.

1.3.2 Results of the Voice Intelligibility tests conducted on this unit are not yet available. Analysis of these tests are to be conducted by the Defense Communications Engineering Center (DCEC) and it is expected that DCEC will publish those results.

1.3.3 Quasi-Analog Signal Tests

1.3.3.1 The Quasi-Analog Signal tests revealed that at an 8 kbps channel sampling rate the ULM-101 would not output useable data with an input from any of the signal sources.

1.3.3.2 At a channel sampling rate of 16 kbps, useable data could be obtained with on transit once through the ULM-101 for input signals from the modems that utilize Frequency Shift Keying (FSK). Useable data could not be obtained with inputs from the Voice Frequency Telegraph Carrier (VFCT) and the Quadrature Phase Shift Keying (QPSK) signal sources.

1.3.3.3 At a channel sampling rate of 32 kbps, the ULM-101 could process both modem signal types (QPSK & FSK) error-free for one transit. Useable data could be obtained for two to seven loopbacks depending on the modem and the modem bit rate. VFCT signals were marginal.

1.3.3.4 At a channel sampling rate of 64 kbps, the ULM-101 could process the modem signals error-free for a single transit and without significant data degradation up to six or seven loopbacks. VFCT signals were still marginal.

1.3.3.5 Details of specific tests are provided in Section 3.

1.3.4 The performance of the ULM-101 with the various quasi-analog signal sources in an error environment demonstrate only slight degradation with error rates of 1×10^{-7} to 1×10^{-3} injected in the multiplexer digital group output. An injected error rate of 1×10^{-2} produced significant degradation in performance.

1.3.5 Results of the synchronization tests showed that the ULM-101 could acquire and maintain synchronization even in an extremely severe error environment.

1.4 CONCLUSIONS AND RECOMMENDATIONS

1.4.1 In general, the ULM-101 is more capable of processing a FSK signal accurately than a QPSK signal, especially in an error environment. Because of the coding technique (CVSD), the ULM-101 is capable of transmitting a quasi-analog signal in a fairly high error environment and still provide an acceptable error rate at the receive terminal, especially at sampling rates of 32 and 64 kbps. The ULM-101 was designed to be a voice type CVSD multiplexer and several of the design parameters, such as syllabic integration, were optimized for voice. If the unit were optimized for quasi-analog signals, such as by extending the frequency response limits and concentrating on constant group delay across this frequency band, it is expected that better performance with quasi-analog signals could be obtained.

1.4.2 The ULM-101 is not recommended for use in the DCS. The advantage of the CVSD coding technique that allows a reduction in bandwidth is not yet fully exploited by the ULM-101. However, future development of this type of multiplex is recommended, and specific attention should be provided to the design parameters to allow use of the quasi-analog sources. As a first step in the development, the ULM-101 performed well.

2. GENERAL

2.1 Description of Equipment

2.1.1 The General Dynamics Model ULM-101 Universal Loop Multiplex uses a Continuously Variable Slope Delta (CVSD) modulation algorithm to encode analog channel input signals. In delta modulation, the difference between the instantaneous value of the input signal and the quantized value at the previous sampling instant is quantized. It is not the magnitude of the difference which is coded, but the sign; if the difference is positive a pulse is transmitted, causing the quantized value of the signal to rise by one quantizing unit in the receiver. If the difference is negative no pulse is sent out; the receiver reacts to this by making the quantized signal decrease by one unit. Since no more than one pulse is sent out in every sampling interval, the bit rate is equal to the sampling rate. In CVSD, as implemented in the ULM-101, the output developed by the receiver is a function of the number of successive "1's" or "0's". Up to a maximum of three successive pulses, the level of the signal reproduced by the receiver increases in a positive direction in increments of increasing size for each "1". A succession of "zeros", up to a maximum of three, produces the same effect in a negative direction. This allows the multiplexer to accurately encode and reproduce signals with high rates of change of amplitude with respect to time. After the fourth successive "one" or "zero", the increment size is fixed at the maximum.

2.1.2 The ULM-101 has three different switch-selectable channel input modes: CVSD, Log CVSD, and digital. The multiplexer has four active channels, with each channel input card providing switch selection among Log CVSD, CVSD and digital processing of the input signal.

2.1.2.1 The CVSD mode encodes an analog channel input signal as described above.

2.1.2.2 The Log CVSD mode operates similarly to the CVSD except that the granularity (the smallest voltage quantizing level) is finer than for CVSD, thus allowing low level input signals to be reproduced more accurately.

2.1.2.3 In the digital mode the CVSD coding circuit is bypassed and a digital input signal at the proper channel rate can be introduced

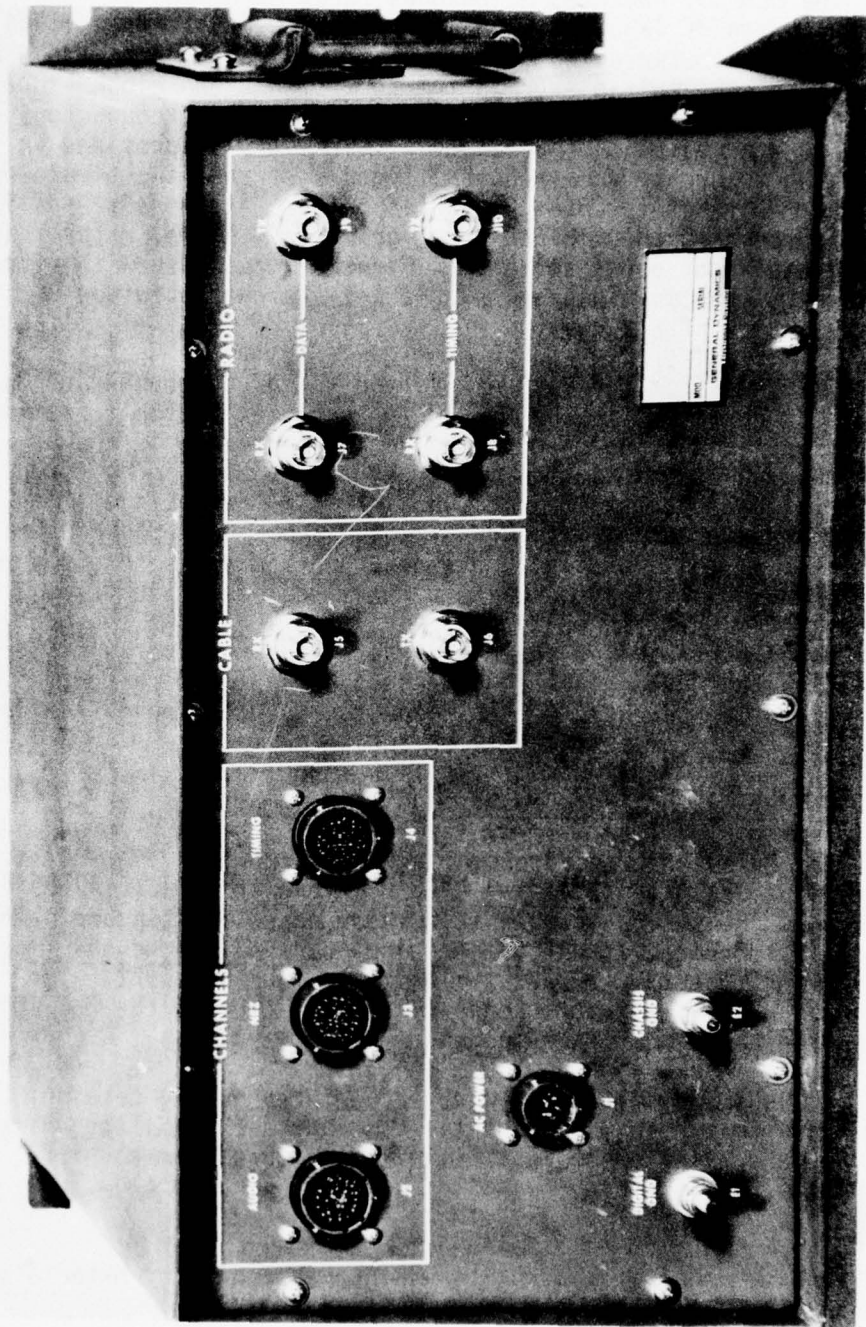

Figure 2. ULM-101, Back View

directly into the multiplexing circuitry. In this manner, any mix of up to four digital and/or analog signals can be multiplexed together in the unit.

2.1.3 The ULM-101 operates at channel rates of 8, 16, 32, and 64 kbps and group rates of 128, 256, 288, 512, and 576 kbps and at 1.544 Mbps. The group rates between 128 and 576 kbps are available on the "radio" connectors of the multiplexer in the form of NRZ and clock signals. The 1.544 Mbps rate is only available on the "cable" connectors of the ULM-101 as a RZ bi-polar (TJ) signal. Circuitry is provided in the multiplexer to create dummy channel signals so that the simulated channel capacity of the ULM-101 varies between 7 channels and 192 channels depending on combination of group and channel rates that are selected via front panel switches. Figures 1 and 2 show the front and back views of the multiplexer. Table I lists the interface characteristics of the unit.

2.1.4 The data from the four active and the proper number of dummy channels is formatted in the ULM-101 transmitter section; framing information, consisting of a pseudo random sequence, is added. The composite data stream is then converted to NRZ and timing for a radio link, or bipolar format for a cable link. In the receiver, the bit synchronizer extracts timing and NRZ data from the 1.544 Mbps bipolar data stream or, alternatively, NRZ data and timing is received directly from the radio link input and the data is routed to the frame synchronizer within the multiplex receiver. The frame synchronizer determines the start of a frame and causes the receiver section to demultiplex the data in the correct sequence. The data for the four active channels is routed to the respective channel output cards for conversion to the proper digital or analog format.

2.2 Test Methodology and Limitations

2.2.1 The detailed procedures contained in the test plan "Test Plan General Dynamics Analog/Digital CVSD Multiplexer" USACEEIA Publication No. CCC-TED-76-TR-226, October 1976, were based on standard methods such as are documented in "DCS Technical Control Procedures, Test Description", DCAC 310-70-1, Supplement 1, November 1972. The procedures were modified for specific application to the ULM-101 and to incorporate new types of instrumentation.

2.2.2 No unusual limitations were encountered during testing. Limits on the data were established by the accuracy and stability of the test equipment and all items were constantly monitored for correct calibration.¹

¹ Calibration Requirements for the Maintenance of Army Materials, DA TB 43180, December 1975.

Table I. ULM-101 Interface Characteristics

Function	Channel Input/Output	Group Input/Output Cable	Group Input/Output Radio
Termination	Balanced 4-wire	Balanced	Single Ended
Impedance	600 Ω <u>+10%</u>	100 Ω <u>+10%</u>	78 Ω <u>+10%</u>
Longitudinal Balance	>40dB	>40dB	---
Transmission Format	NRZ and timing or analog	Bipolar	NRZ and Timing
Transmission Rate	16/32/64 kbps digital/ 300-3500 Hz Voice	1.544 Mbps	128, 144, 256, 288, 512, 576 kbps
Input Signal Level	0.15v p-p to 3.0v p-p	0.15v p-p to 6v p-p	TTL Compatible
Output Signal Level	3v p-p <u>+10%</u>	6v p-p <u>+10%</u>	TTL Compatible
Output Drive	4 Km	3.2 Km	---

2.3 ULM-101 Equipment Modification. Efforts to perform an envelope delay measurement on the ULM-101 were unsuccessful when first attempted. A check of waveforms with an oscilloscope revealed that the amplitude modulated test signal introduced by the measuring set had its negative portion clipped by the loop integrator on the channel output card. A 0.047 microfarad capacitor was inserted in the line between the loop integrator output and driver input on each channel output card. This allowed the amplitude modulated envelope delay test signal to pass through the output undisturbed. It did affect the response of the output circuitry; signals below 500 Hz were attenuated with respect to the response of the unmodified channel output card. A 5 dB degradation at 200 Hz was noted on the modified circuit. This capacitor was in place for all tests except as noted.

3. DETAILS OF TEST

3.1 Channel Level Tests

3.1.1 Frequency Response Test

3.1.1.1 Objective. The purpose of this test was to define the passband and out-of-band characteristics of the ULM-101 analog input/output circuitry. The multiplex is specified to have the passbands listed in Table II.

TABLE II - ULM-101 Passband Specifications

<u>Channel Rate (kbps)</u>	<u>Passband (Hz)</u>
8	300-1500
16	300-2000
32	300-3800
64	300-3800

3.1.1.2 Procedure

3.1.1.2.1 Figure 3 depicts the equipment configuration for this test. The output frequency and level of the audio oscillator were first set using the frequency selective voltmeter. The frequency selective voltmeter used had a measurement bandwidth of 10 Hz.

3.1.1.2.2 The frequency response of the ULM-101 was measured at input levels of 0 dBm and -13 dBm, and for all combinations of multiplexer coding technique and channel sampling rates. A multiplexer group rate of 1.544 Mbps was used throughout the test. Testing with each

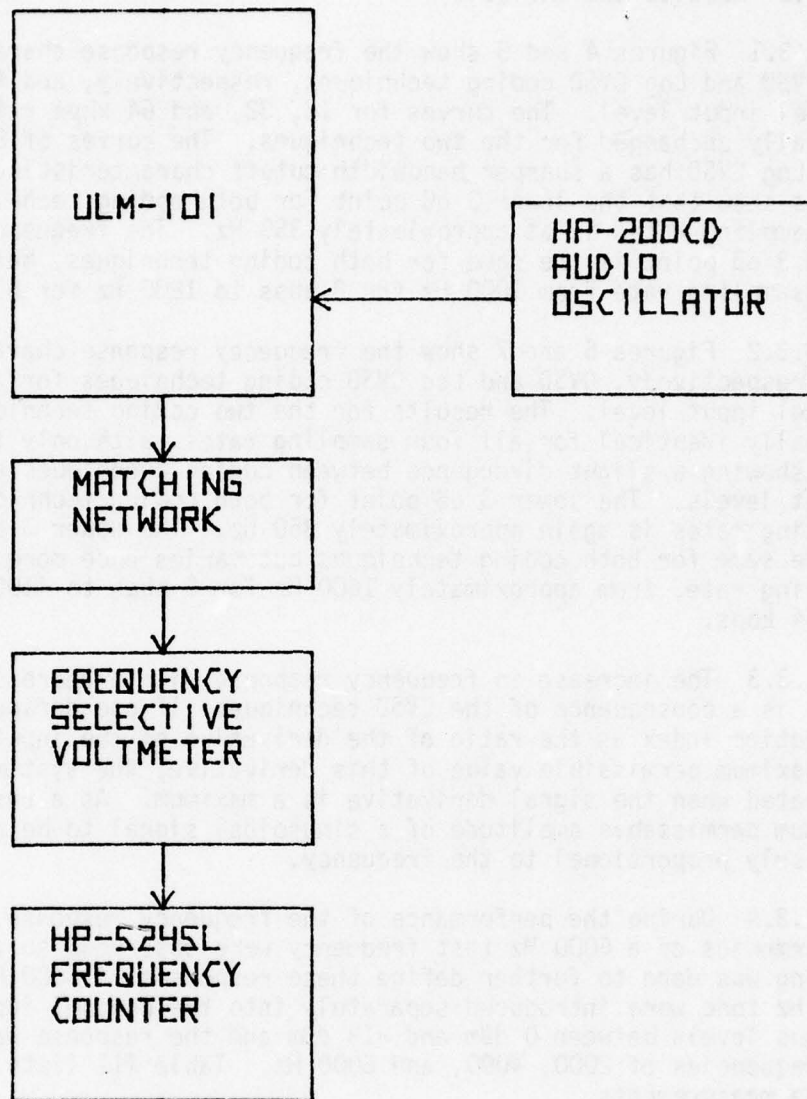

FIGURE 3. FREQUENCY RESPONSE TEST CONFIGURATION

combination of multiplexer settings was continued up to the frequency at which the output was a minimum of 30 dB lower than the input.

3.1.1.3 Results and Analysis

3.1.1.3.1 Figures 4 and 5 show the frequency response characteristics for CVSD and Log CVSD coding techniques, respectively, and for a 0 dBm channel input level. The curves for 16, 32, and 64 kbps rates are virtually unchanged for the two techniques. The curves of 8 kbps show that Log CVSD has a sharper bandwidth cutoff characteristic. The curves show that the lower 3 dB point for both coding techniques and all sampling rates is at approximately 350 Hz. The frequency for the upper 3 dB point is the same for both coding techniques, but varies with sampling rate from 1000 Hz for 8 kbps to 1800 Hz for 64 kbps.

3.1.1.3.2 Figures 6 and 7 show the frequency response characteristics for, respectively, CVSD and Log CVSD coding techniques for a -13 dBm channel input level. The results for the two coding techniques are virtually identical for all four sampling rates, with only the 8 kbps rate showing a slight divergence between coding techniques at low output levels. The lower 3 dB point for both coding techniques and all sampling rates is again approximately 350 Hz. The upper 3 dB frequency is the same for both coding techniques but varies once more with sampling rate, from approximately 1600 Hz for 8 kbps to 4100 Hz for 32 and 64 kbps.

3.1.1.3.3 The increase in frequency response with a decrease in input level is a consequence of the CVSD technique. If one defines a modulation index as the ratio of the derivative of the input signal to the maximum permissible value of this derivative, the system is fully modulated when the signal derivative is a maximum. As a result, the maximum permissible amplitude of a sinusoidal signal to be coded is inversely proportional to the frequency.

3.1.1.3.4 During the performance of the frequency response test, subharmonics of a 6000 Hz test frequency were observed, so additional testing was done to further define these responses. A 6000 Hz and a 2000 Hz tone were introduced separately into the channel input at various levels between 0 dBm and -13 dBm and the response was measured at frequencies of 2000, 4000, and 6000 Hz. Table III lists the results of the measurements.

3.1.1.3.5 The responses listed in Table III were observed for an ULM-101 sampling rate of 64 kbps and for both CVSD and Log CVSD coding techniques. A sampling rate of 32 kbps produced very similar results while no responses were observed for rates of 8 and 16 kbps. The lack of response at rates of 8 and 16 kbps is probably due to the much narrower channel bandwidth at these rates which results in a very high attenuation to the 6000 Hz signal.

3.1.1.3.6 A review of Table III reveals that the channel reacts in a radically different manner to signals in-band and out-of-band as far as

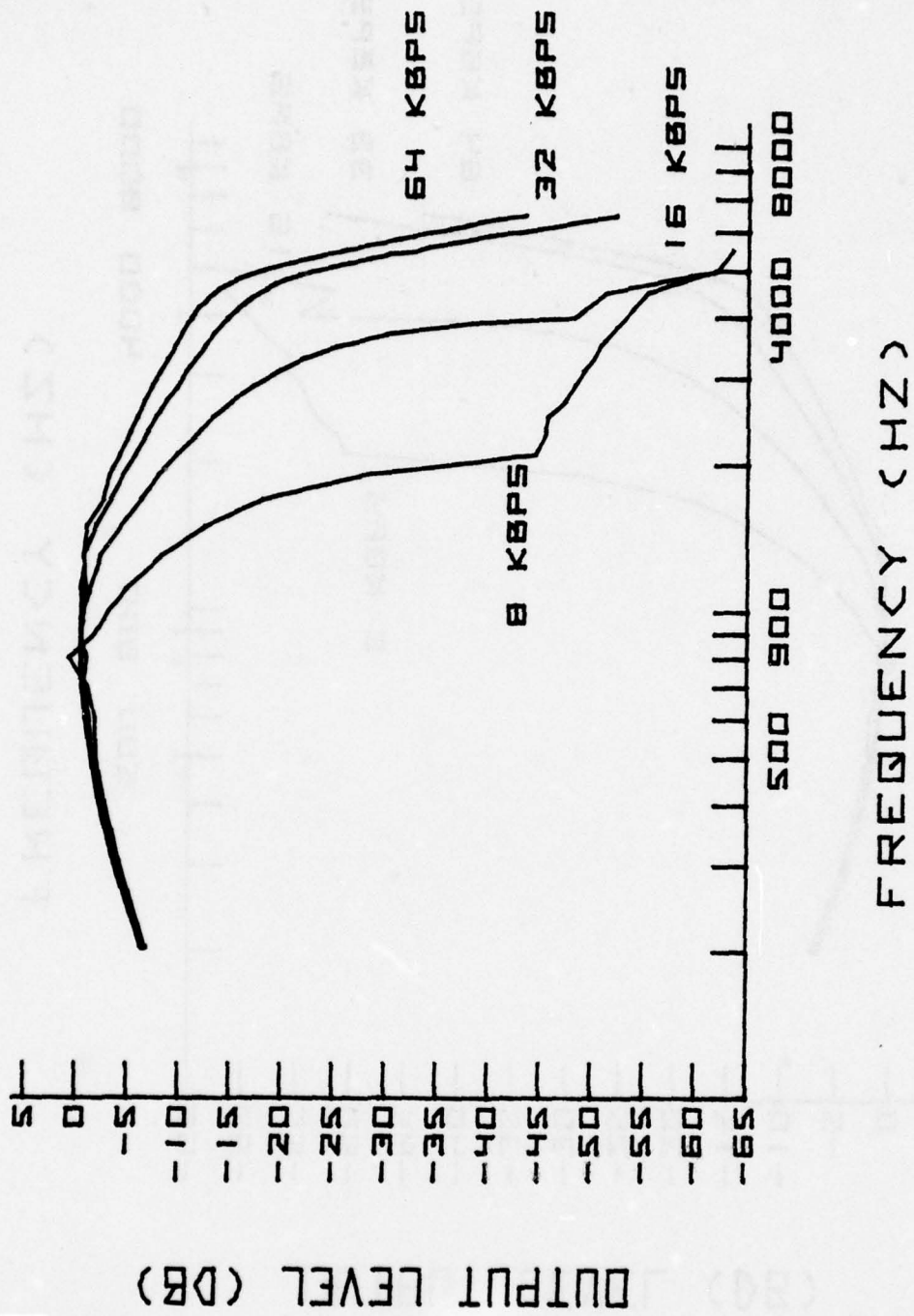

FIGURE 4. FREQUENCY RESPONSE, CVSD
0 DBM INPUT

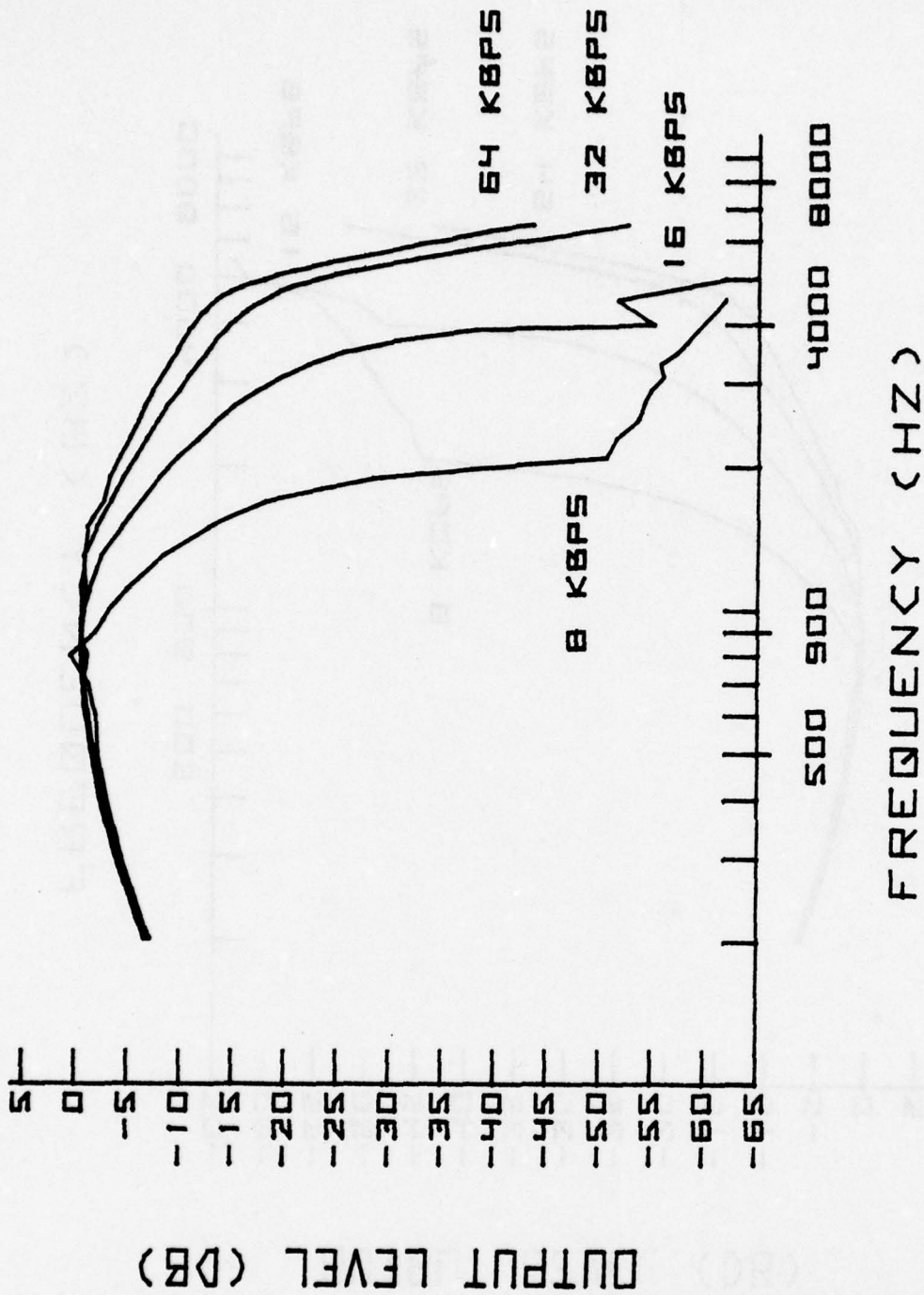

FIGURE 5. FREQUENCY RESPONSE, LOGCVSD
0 DBM INPUT

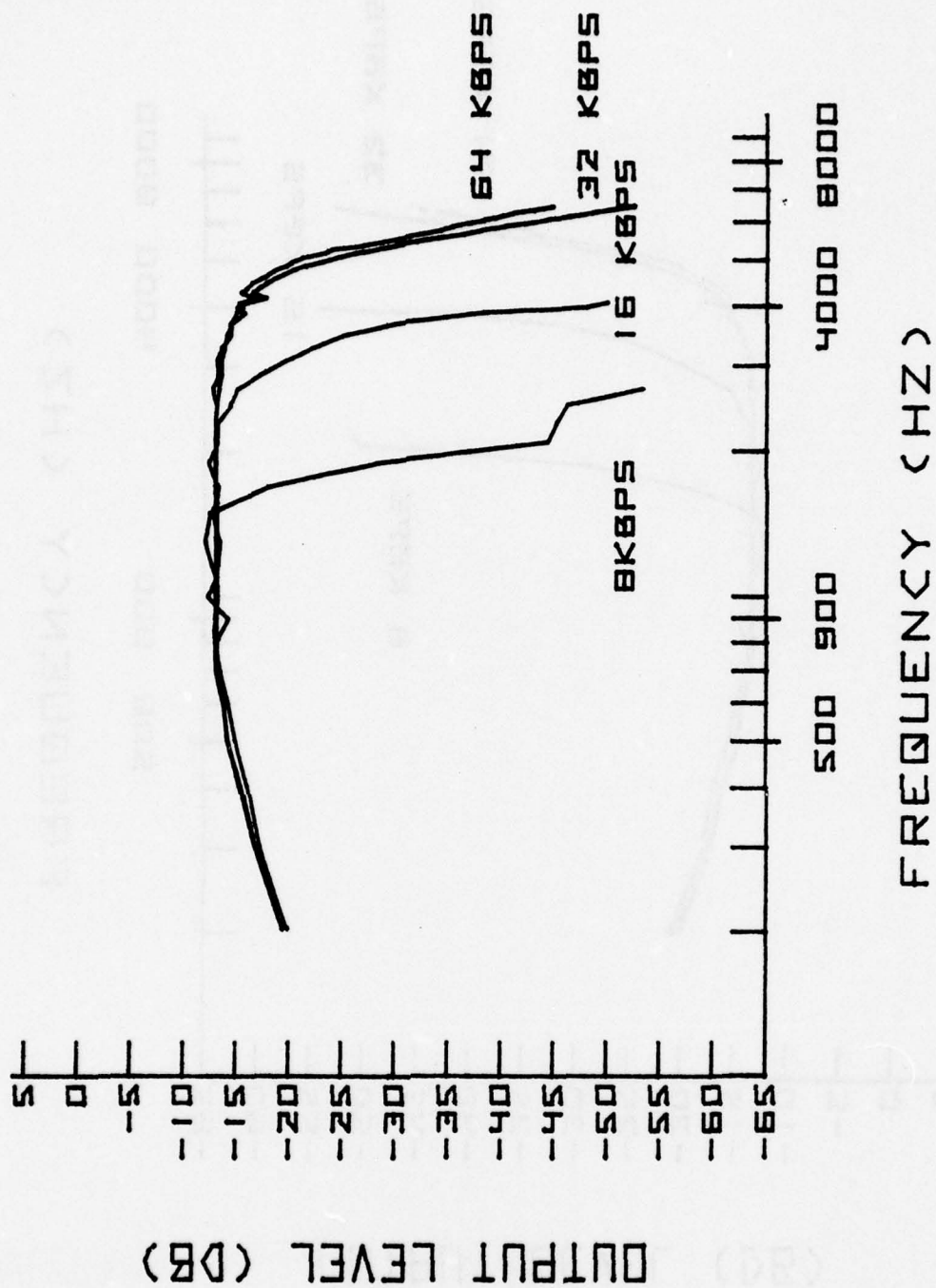

FIGURE 6. FREQUENCY RESPONSE, CVSD
 - 13 DBM INPUT

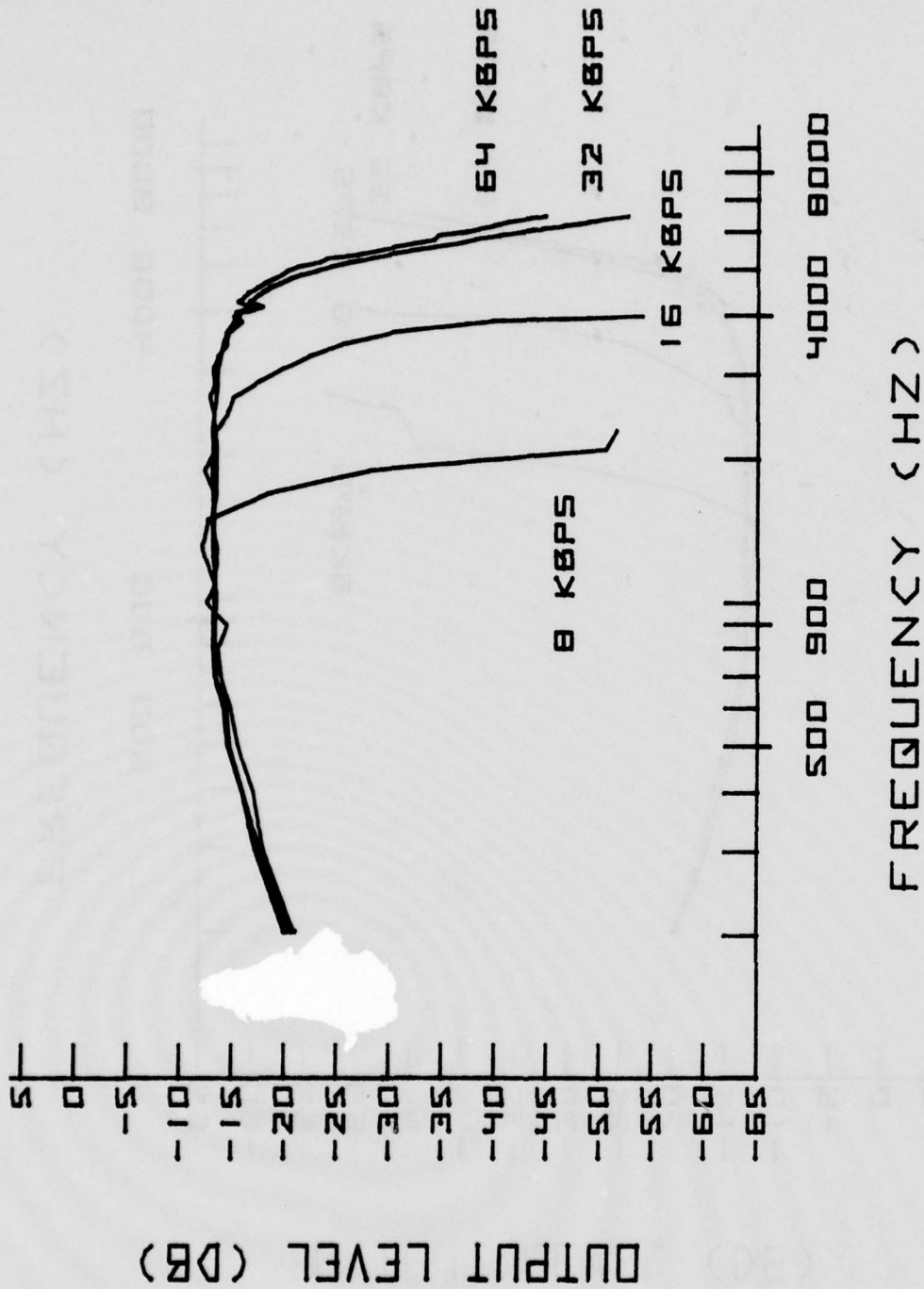

FIGURE 7. FREQUENCY RESPONSE, LOGCVSD
 - 13 DBM INPUT

harmonics are concerned. The 2000 Hz input signal resulted in a reasonably constant second harmonic signal level and relatively little third harmonic content once the signal falls below 0 dBm. By contrast, the third sub-harmonic of the 6000 Hz input signal is higher in level than the fundamental down to an input level of -8 dBm. The 2000 Hz product generally decreases in level with a decrease in input level, while the 6000 Hz signal remains constant in output level at input levels between 0 dBm and -10 dBm.

3.1.1.3.7 The spurious responses observed for a 6000 Hz input signal could not be thoroughly checked through the ULM-101 circuitry because extensive use is made of operational amplifiers and no instrumentation was available with a high enough input impedance to avoid loading down the outputs from these amplifiers. The spurious signals apparently originate from the circuitry which performs the analog-to-digital or digital-to-analog transformations of the channel input signal. The analog signal from the channel output card originates in the analog decision circuitry as an amplitude modulated digital waveform (at the channel sampling rate) from which the analog signal is derived by the loop integrator, amplified by a driver, and band-limited by an output low pass filter with an 18 dB/octave roll-off starting at approximately 5 kHz. The processing and band-limiting characteristics of the circuitry are not conducive to the generation of spurious signals at the levels observed.

3.1.1.3.8 The analog signal at the "Audio In" port of the channel input card is amplified and then band-limited by a low pass filter comprised of an operational amplifier and passive components. It is possible that the spurious responses are generated as resonances in the filter which then propagate through the system.

Table III. ULM-101 Harmonic Responses

Channel Input		Channel Output (dBm)		
Freq (Hz)	Level (dBm)	2000 Hz	4000 Hz	6000 Hz
6000	0	-28	-61	-34
	-3	-30.5	-45	-34
	-5	-33	-42	-34
	-8	-28	-45	-34
	-10	-43	-40	-34
	-11	-48	-45	-36
	-13	-60	-53	-97.5
2000	0	- 3.5	-40.5	-41
	-10	-10	-37	<-60
	-13	-13.3	-45	<-60

3.1.2 Linearity Test

3.1.2.1 Objective. The purpose of this test was to define the linearity characteristics of the analog channels of the ULM-101.

3.1.2.2 Procedure

3.1.2.2.1 Figure 8 depicts the equipment configuration for this test. The audio oscillator was adjusted to provide an input level to the ULM-101 of 0 dBm at 1000 Hz, as measured by the frequency selective voltmeter. The attenuator was then used to reduce the signal at the input to the multiplexer to the desired level. The frequency selective voltmeter was used with a measurement bandwidth of 10 Hz.

3.1.2.2.2 The linearity of the ULM-101 was measured for both coding techniques and for all four sampling rates. Testing was continued down to an input level at which non-linear operation was apparent.

3.1.2.3 Results and Analysis

3.1.2.3.1 Figures 9 and 10 show the linearity characteristics of the ULM-101 for CVSD and Log CVSD coding techniques, respectively. A straight line equation was developed using a least squares technique for the data for each combination of coding technique and sampling rate. The computed lines for Log CVSD for 16, 32, and 64 kbps sampling rates were slightly more linear than for CVSD coding; the slope for Log CVSD varied by no more than 0.5% from a value of 1 while the variation for CVSD was approximately 5% from a value of 1.

3.1.2.3.2 The obvious nonlinearity of the curves for an 8 kbps sampling rate on figures 9 and 10 were reflected in the calculated best straight lines through the data points. The slope for CVSD coding technique was .910 and the standard error of estimate for any point on this line was .74. For Log CVSD the calculated slope was .953 with a standard error of estimate of .77.

3.1.2.3.3 The curves shown in figures 9 and 10 become nonlinear at very low input levels -- less than -40 dBm for all sampling rates except 8 kbps -- due to the fact that the level of the input signal is approaching the granularity of the delta coder. For the type of signals that the CVSD multiplexer will normally process, this will create no difficulty.

3.1.3 Crosstalk Test

3.1.3.1 Objective. The purpose of this test was to determine the crosstalk levels observed between two adjacent analog channel inputs on the ULM-101.

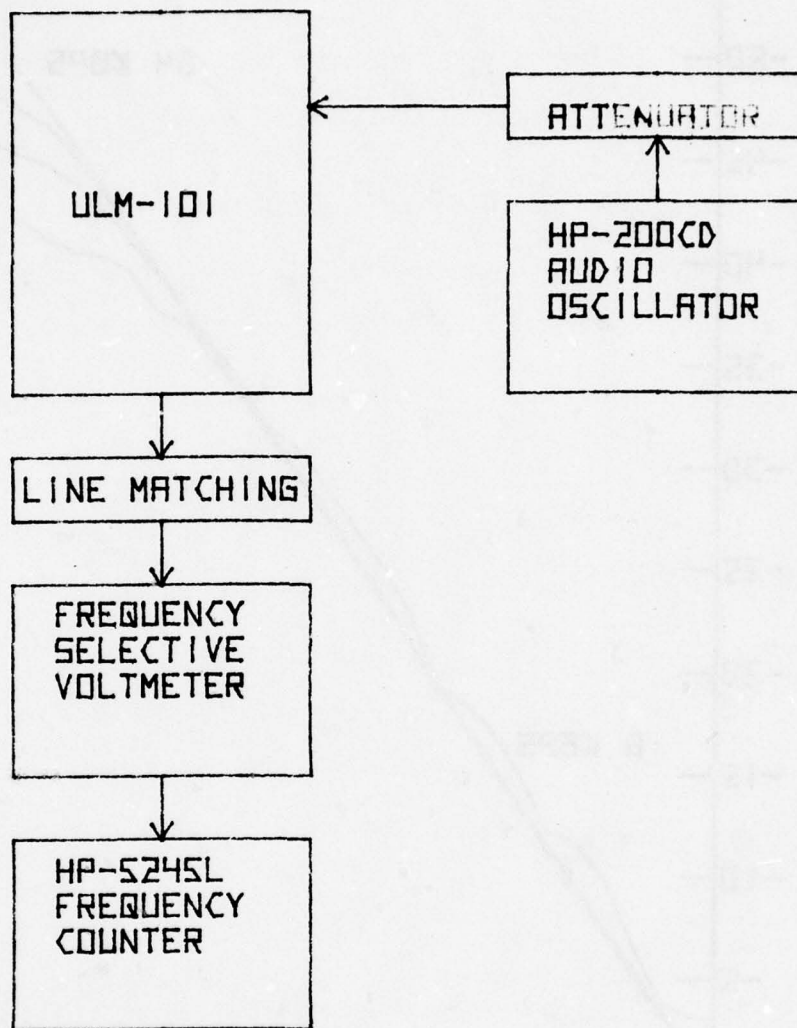

FIGURE 8. LINEARITY TEST CONFIGURATION

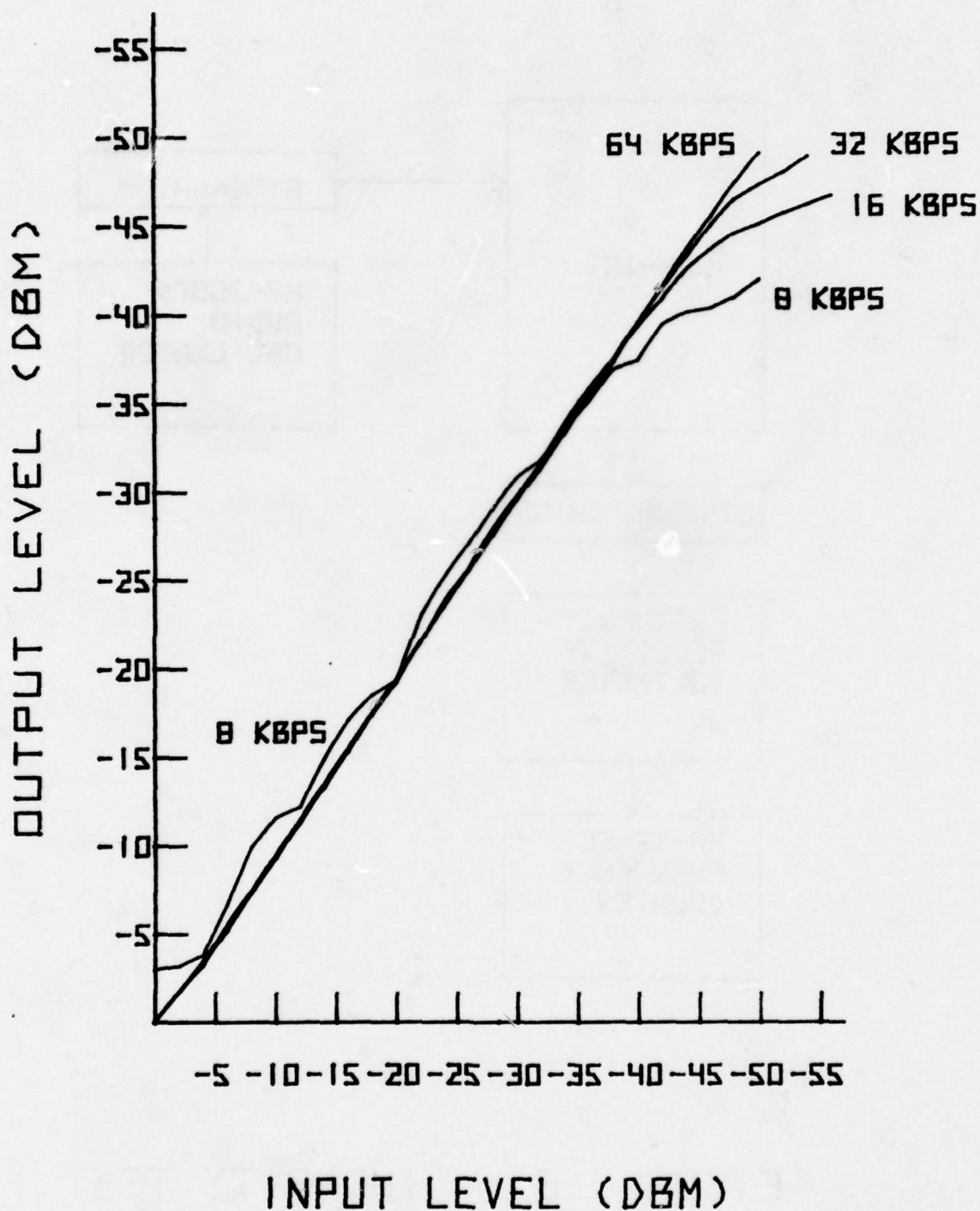

FIGURE 9. LINEARITY (VSD)

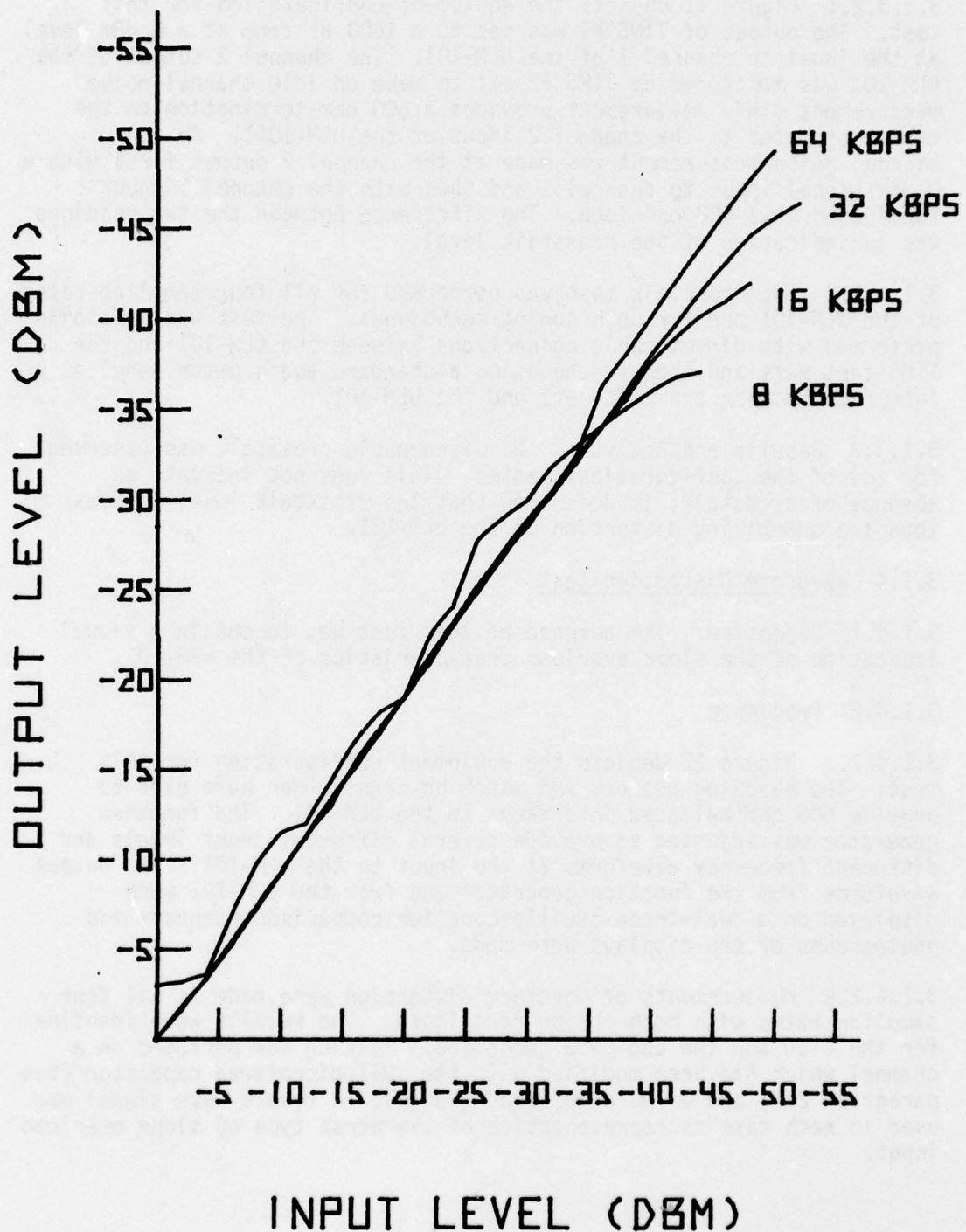

FIGURE 10. LINEARITY LOGCVSD

3.1.3.2 Procedure

3.1.3.2.1 Figure 11 depicts the equipment configuration for this test. The output of TIMS #1 was set to a 1000 Hz tone at a 0 dBm level at the input to channel 1 of the ULM-101. The channel 2 output of the ULM-101 was monitored by TIMS #2 set to make an idle channel noise measurement (this measurement provides a 600 ohm termination on the cable connected to the channel 2 input of the ULM-101). An idle channel noise measurement was made at the channel 2 output first with a 0 dBm signal input to channel 1 and then with the channel 1 input terminated in a 600 ohm load. The difference between the two readings was an indication of the crosstalk level.

3.1.3.2.2 The crosstalk test was performed for all four sampling rates of the ULM-101 and for both coding techniques. The test was initially performed with direct cable connections between the ULM-101 and the TIMS test sets and then redone using a standard audio patch panel as an interface between the test sets and the ULM-101.

3.1.3.3 Results and Analysis. No discernable crosstalk was observed for any of the configurations tested. This does not indicate an absence of crosstalk; it does show that the crosstalk level is less than the quantizing distortion of the ULM-101.

3.1.4 Waveform Distortion Test

3.1.4.1 Objective. The purpose of this test was to obtain a visual indication of the slope overload characteristics of the ULM-101.

3.1.4.2 Procedure

3.1.4.2.1 Figure 12 depicts the equipment configuration for this test. The matching network and matching transformer were used to provide 600 ohm balanced interfaces to the ULM-101. The function generator was adjusted to provide several different input levels and different frequency waveforms at the input to the ULM-101. The output waveforms from the function generator and from the ULM-101 were displayed on a dual-trace oscilloscope for comparison purposes and photographs of the displays were made.

3.1.4.2.2 Measurements of waveform distortion were made at all four sampling rates with both coding techniques. The results were identical for the CVSD and the Log CVSD technique. Testing was performed on a channel which had been modified with the .047 microfarad capacitor (see paragraph 2.3) and on an unmodified channel. A square wave signal was used in each case as representative of the worst type of slope overload input.

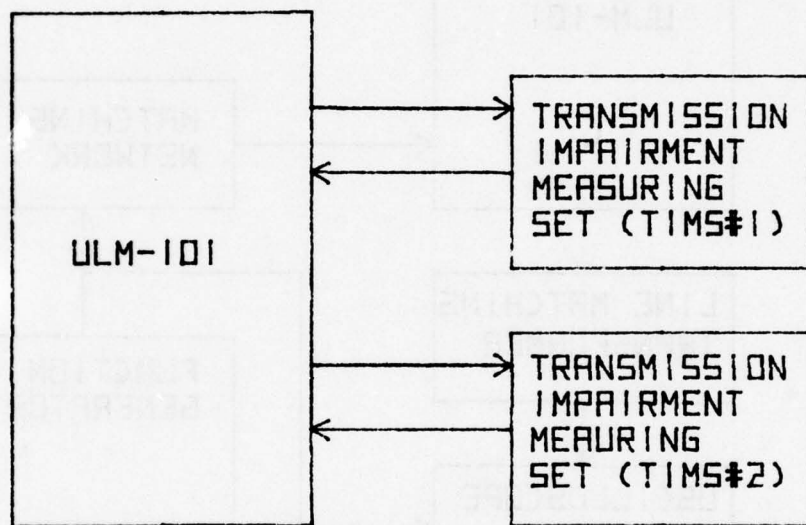

FIGURE 11. CROSSTALK TEST CONFIGURATION

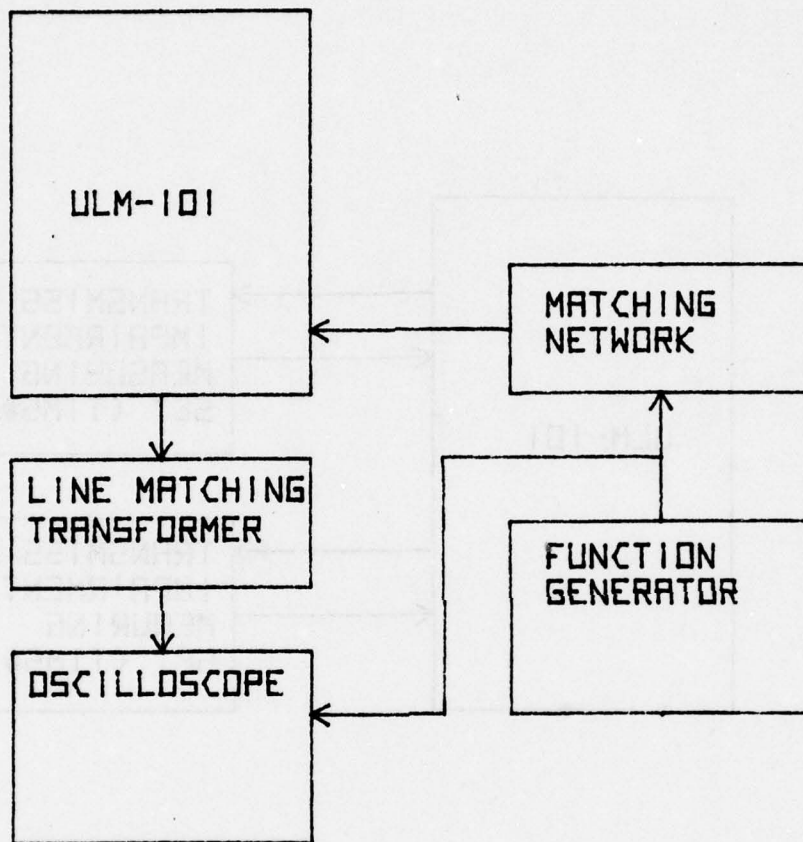

FIGURE 12. WAVEFORM DISTORTION TEST CONFIGURATION

3.1.4.3 Results and Analysis

3.1.4.3.1 Figure 13 shows the function generator outputs and ULM-101 outputs for -10 dBm 1800 Hz signal. The upper photograph shows the waveform for a 64 kbps sampling rate; the lower photograph shows the waveform for an 8 kbps sampling rate, with quantizing distortion clearly evident. The waveforms for 16 and 32 kbps were identical to that for 64 kbps. The modified channel was used for these measurements. The waveforms shown are the result of both slope overload and bandwidth effects in the multiplexer channel circuitry.

3.1.4.3.2 Figure 14 shows the function generator outputs and ULM-101 outputs for a 500 Hz square wave at -10 dBm and -20 dBm input levels at the input to the modified channel of the multiplexer. The upper photograph shows the type of waveform obtained for all four sampling rates with a -10 dBm input level. Slope overload and bandwidth limiting are still evident, but the reproduction of the input waveform is better than with an 1800 Hz signal. The lower photograph shows the type of waveform obtained for all sampling rates with a -20 dBm input level. The output waveform is degraded, with a very low signal-to-noise ratio.

3.1.4.3.3 Figure 15 shows the function generator outputs and ULM-101 outputs for a 1750 Hz square wave at a -10 dBm input level at the unmodified channel of the multiplexer. The upper photograph shows the type of waveform obtained for sampling rates of 32 and 64 kbps; this waveform is virtually identical to that obtained with the modified channel with a -10 dBm, 1800 Hz square wave input. The lower photograph shows the type of waveform obtained for sampling rates of 8 and 16 kbps; the ringing on the waveform obtained for a similar input signal to the modified channel is missing from the waveform.

3.1.4.3.4 Figure 16 shows the function generator outputs and ULM-101 outputs for a 500 Hz square wave at a -10 dBm input level at the unmodified channel of the multiplexer. The upper photograph show the type of waveform obtained for sampling rates of 16, 32, and 64 kbps. The effects of slope overload are relatively minor, the waveform is reproduced fairly accurately. The lower photograph shows the type of waveform obtained for a sampling rate of 8 kbps. The waveform is recognizable as a square wave, although slope overload effects are still clearly evident.

3.1.4.3.5 Figure 17 shows the function generator outputs and ULM-101 outputs for a 900 Hz square wave at a -20 dBm input level at the unmodified channel of the multiplexer. The upper photograph on the left, representative of sample rates of 16, 32, and 64 kbps, show similar results of those obtained for the -10 dBm, 500 Hz input. The lower photograph, representative of a sampling rate of 8 kbps, shows the signal to be very noisy. The same result was obtained with the modified channel for a similar input signal.

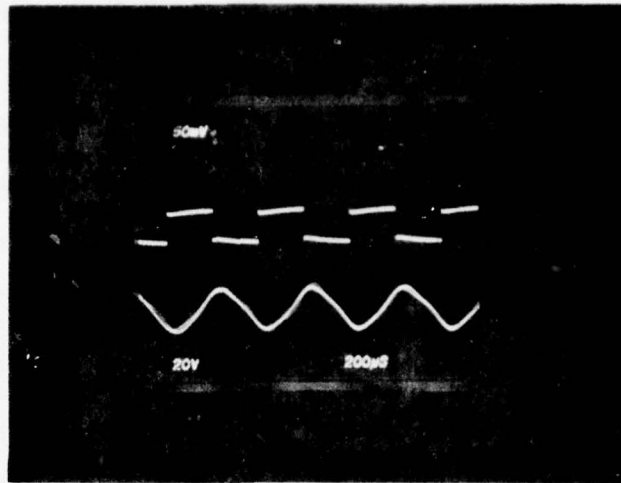

64 KBPS RATE

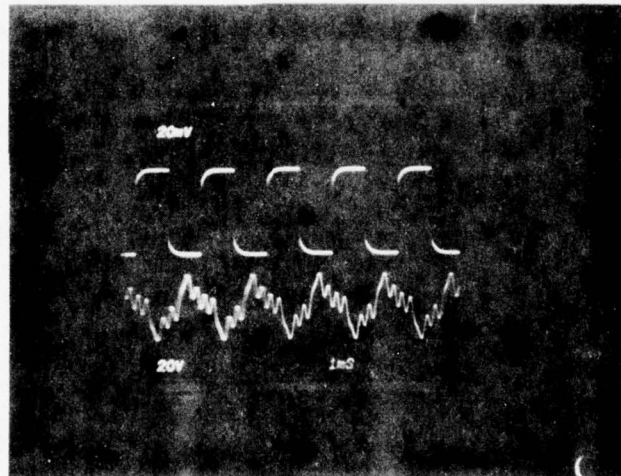

8 KBPS RATE

Figure 13. Waveform Distortion Test, -10 dBm, 1800 Hz Square Wave Input

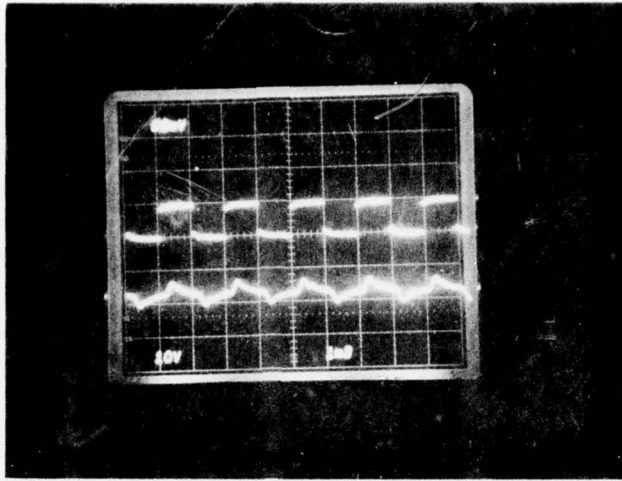

-10 dBm Input

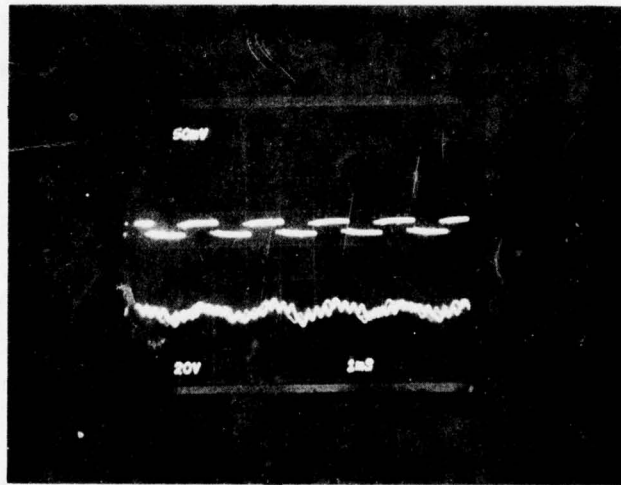

-20 dBm Input

Figure 14. Waveform Distortion Test, 500 Hz Square Wave Input

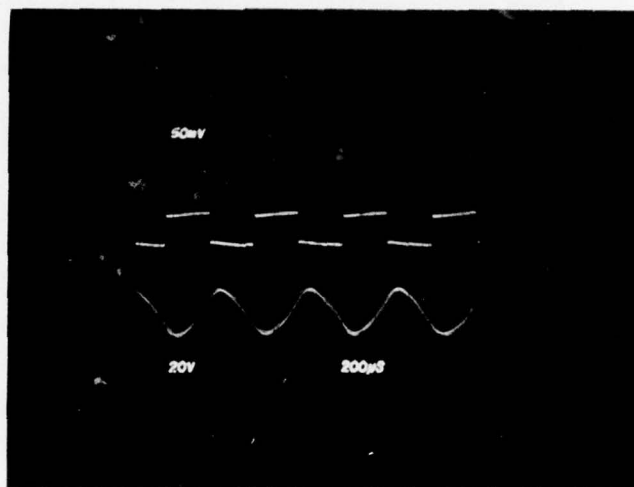

64 KBPS RATE

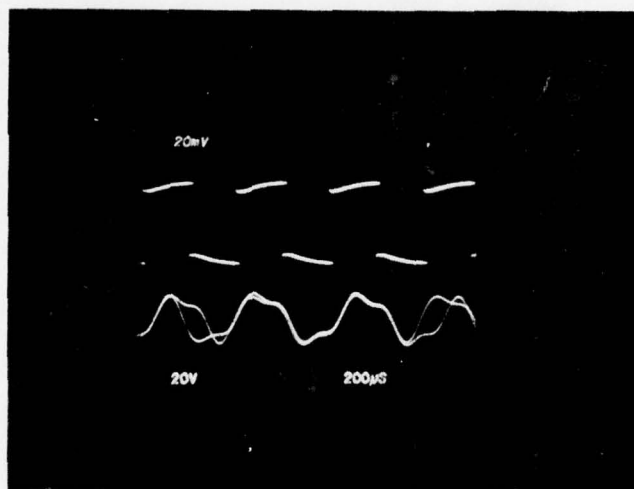

16 KBPS RATE

Figure 15. Waveform Distortion Test, -10 dBm, 1750 Hz Square Wave Input

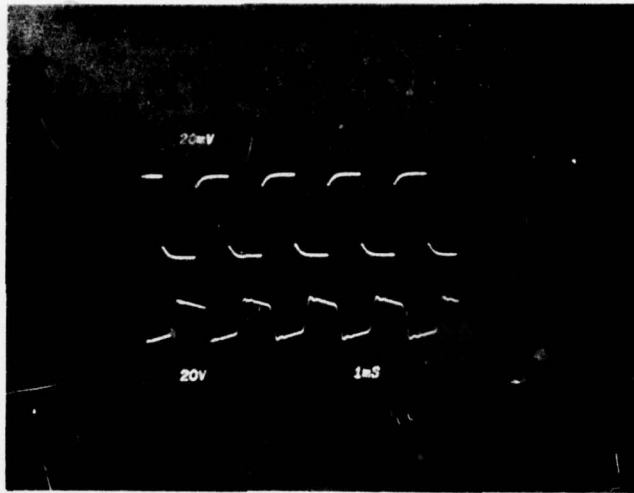

64 KBPS RATE

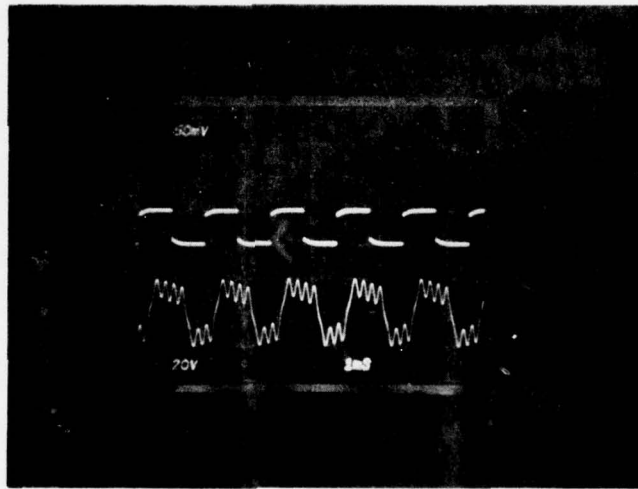

8 KBPS RATE

Figure 16. Waveform Distortion Test, -10 dBm, 500 Hz Square Wave Input

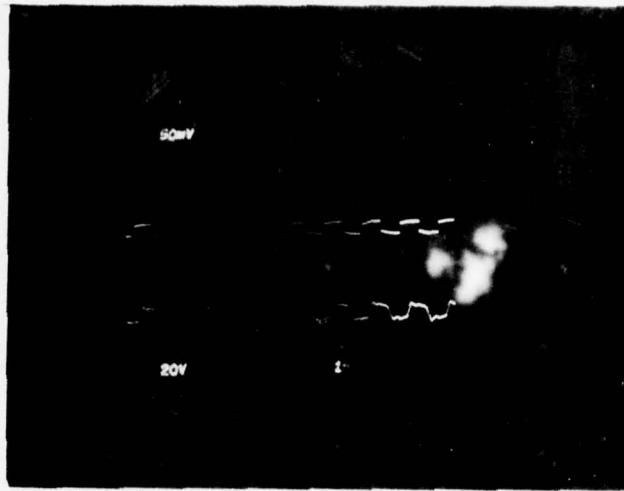

64 KBPS RATE

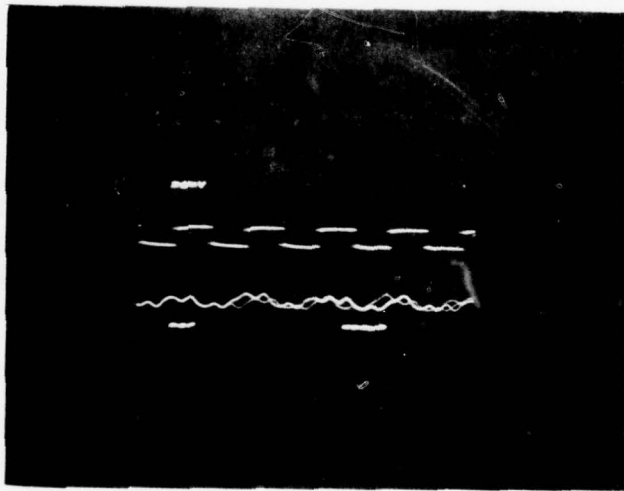

8 KBPS RATE

Figure 17. Waveform Distortion Test, -20 dBm, 900 Hz Square Wave Input

3.1.4.3.6 The results of this test indicate that at a normal operating level of -10 dBm, slope overload effects will result in serious deterioration of any input signal above 500 to 900 Hz with a high rate of change of input amplitude. The ULM-101, as modified for the envelope delay measurement, will not operate without slope overload effect for fast transition waveforms down to the minimum reception level. The unmodified ULM-101 is capable of reproducing a square wave up to 900 Hz at levels between -10 dBm to -20 dBm with some distortion, but with satisfactory accuracy. The difference between the unmodified and modified performance is due to the additional low frequency filtering on the modified channel, which, in effect, double-integrates the output waveform.

3.1.5 Envelope Delay Distortion Test

3.1.5.1 Objective. The purpose of this test was to define the envelope delay characteristics of the ULM-101 analog input/output circuitry.

3.1.5.2 Procedure

3.1.5.2.1 Figure 18 depicts the equipment configuration for this test. The test was conducted in accordance with the instructions contained in the manual for the Hewlett-Packard Model 4940A Transmission Impairment Measurement Set (TIMS).

3.1.5.2.2 The Envelope Delay Measurement test was attempted at input levels of 0 dBm and -13 dBm at the analog input to the ULM-101. The TIMS was unable to establish a loop at a 0 dBm input for any ULM-101 channel rate, so no measurements were made. At a -13 dBm input level, measurements were made at multiplexer channel rates of 16, 32, and 64 kbps for both CVSD and Log CVSD coding techniques. At an 8 kbps rate, with both coding techniques, the TIMS was unable to establish a loop.

3.1.5.3 Results and Analysis

3.1.5.3.1 The loss of loop by the TIMS test set indicates that the 83 1/3 Hz modulation frequency is lost. At a 0 dBm input level for all sampling rates and at an 8 kbps sampling rate for a -13 dBm input level, the distortion of the signal is great enough for the TIMS to interpret the carrier as lacking the required modulation frequency and the set either fails to achieve phase lock or breaks the loop.

3.1.5.3.2 Figures 19 through 21 show the curves of envelope delay as a function of frequency for CVSD coding techniques and channel sampling rates of 16, 32, and 64 kbps. Virtually identical results were obtained for Log CVSD coding techniques. The test set lost loop at 2400 Hz for a 16 kbps sampling rate, 3200 Hz for a 32 kbps sampling and was still in loop at 3900 Hz for a 64 kbps sampling rate where the test was terminated.

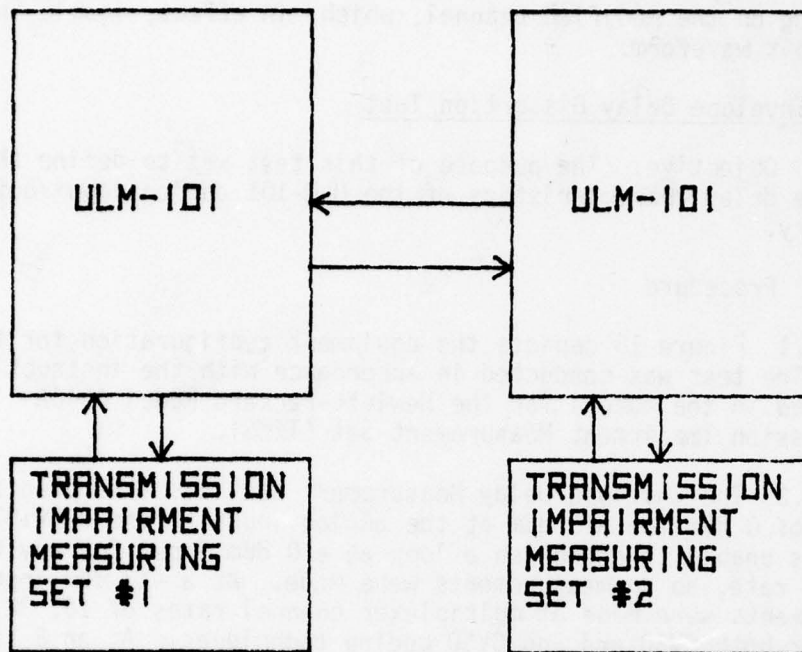

FIGURE 18. ENVELOPE DELAY TEST CONFIGURATION

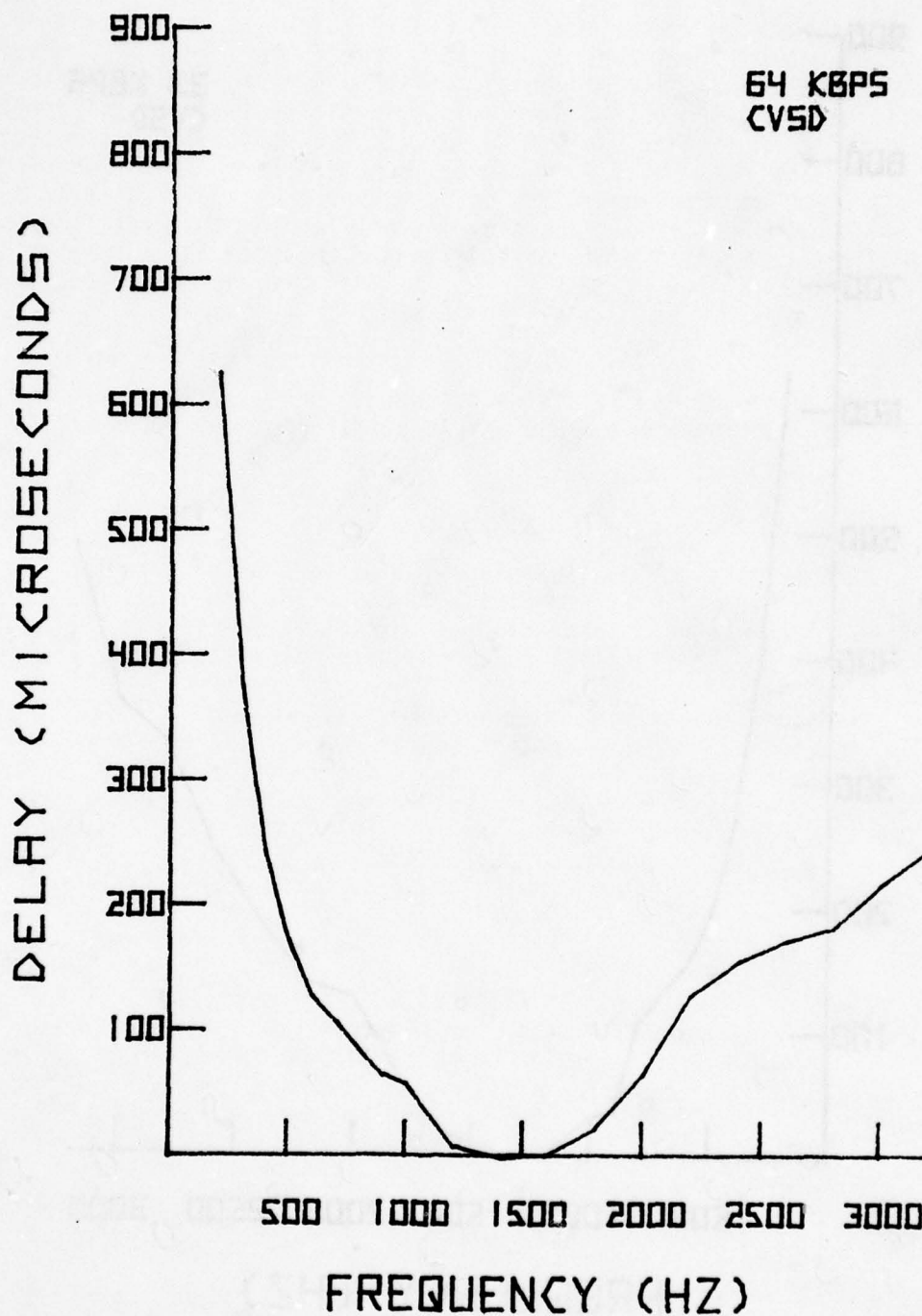

FIGURE 19. ENVELOPE DELAY VS FREQUENCY

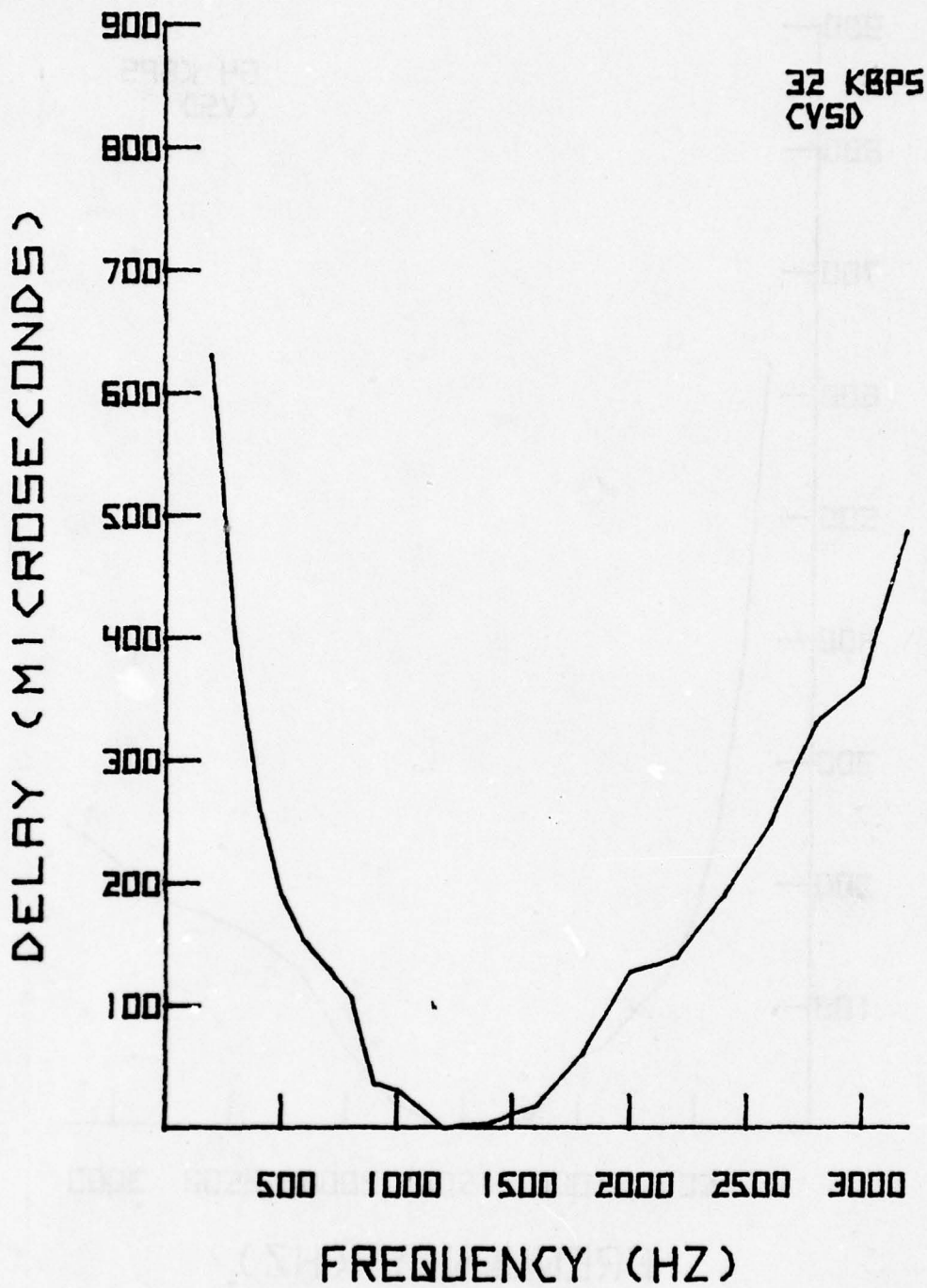

FIGURE 20. ENVELOPE DELAY VS
FREQUENCY

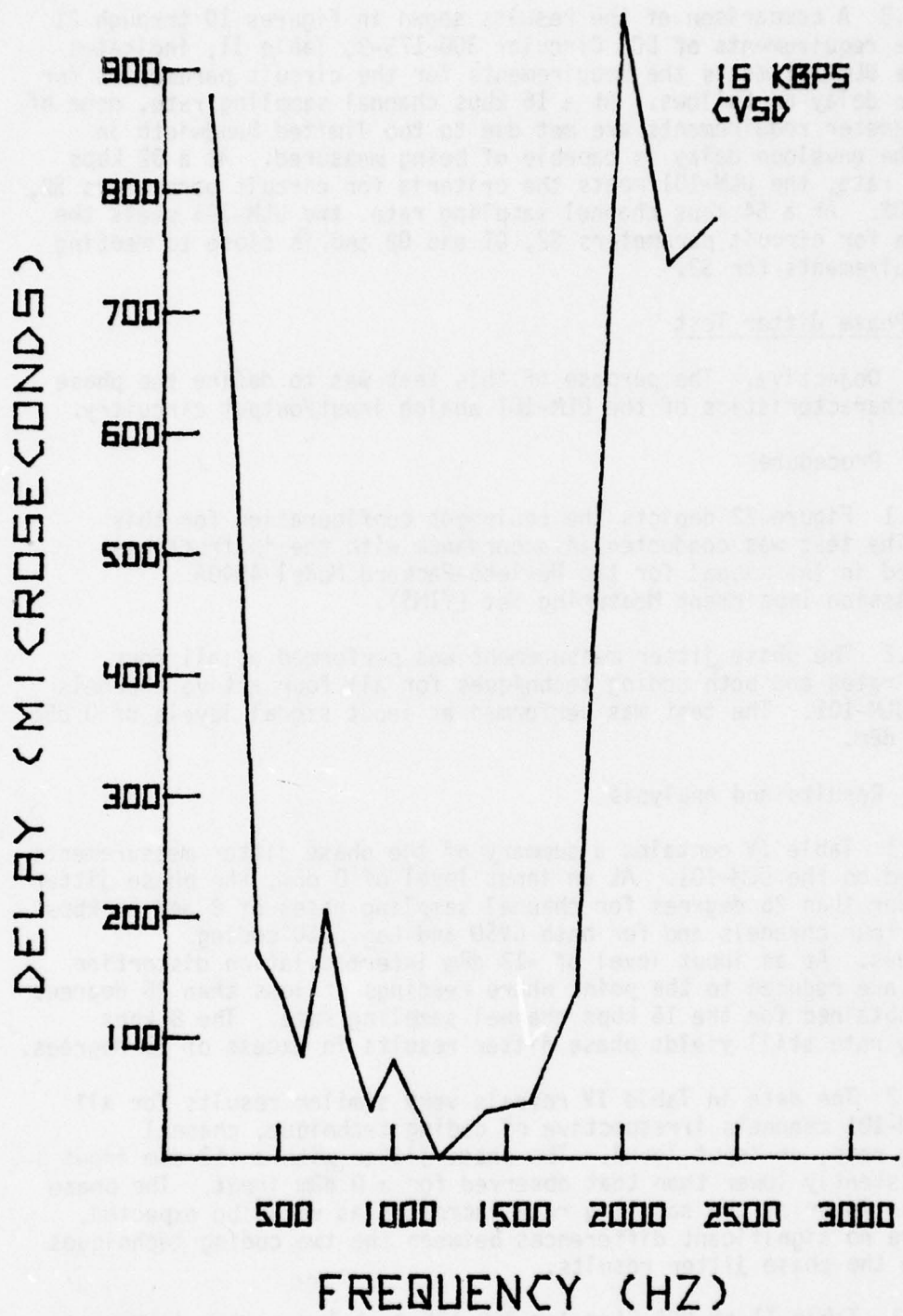

FIGURE 21. ENVELOPE DELAY VS FREQUENCY

3.1.5.3.3 A comparison of the results shown in figures 19 through 21 with the requirements of DCA Circular 300-175-9, Table II, indicates that the ULM-101 meets the requirements for the circuit parameters for envelope delay as follows. At a 16 kbps channel sampling rate, none of the parameter requirements are met due to the limited bandwidth in which the envelope delay is capable of being measured. At a 32 kbps channel rate, the ULM-101 meets the criteria for circuit parameters S2, D1 and D2. At a 64 kbps channel sampling rate, the ULM-101 meets the criteria for circuit parameters S2, D1 and D2 and is close to meeting the requirements for S3.

3.1.6 Phase Jitter Test

3.1.6.1 Objective. The purpose of this test was to define the phase jitter characteristics of the ULM-101 analog input/output circuitry.

3.1.6.2 Procedure

3.1.6.2.1 Figure 22 depicts the equipment configuration for this test. The test was conducted in accordance with the instructions contained in the manual for the Hewlett-Packard Model 4940A Transmission Impairment Measuring Set (TIMS).

3.1.6.2.2 The phase jitter measurement was performed at all four channel rates and both coding techniques for all four active channels of the ULM-101. The test was performed at input signal levels of 0 dBm and -13 dBm.

3.1.6.3 Results and Analysis

3.1.6.3.1 Table IV contains a summary of the phase jitter measurements performed on the ULM-101. At an input level of 0 dBm, the phase jitter is greater than 25 degrees for channel sampling rates of 8 and 16 kbps for all four channels and for both CVSD and Log CVSD coding techniques. At an input level of -13 dBm intermodulation distortion effects are reduced to the point where readings of less than 25 degrees can be obtained for the 16 kbps channel sampling rate. The 8 kbps sampling rate still yields phase jitter results in excess of 25 degrees.

3.1.6.3.2 The data in Table IV reveals very similar results for all four ULM-101 channels irrespective of coding technique, channel sampling rate, or input level. The phase jitter with a -13 dBm input is consistently lower than that observed for a 0 dBm input. The phase jitter is lower as the sampling rate increases as would be expected. There are no significant differences between the two coding techniques shown in the phase jitter results.

3.1.6.3.3 Table II of DCA Circular 300-175-9 states a peak jitter of 15 degrees as being a requirements for circuit parameters S1 through S3

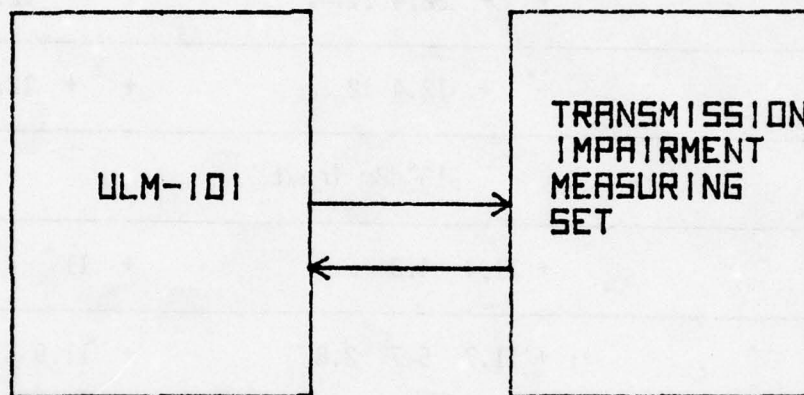

FIGURE 22. PHASE JITTER TEST CONFIGURATION

and D1 and D2. The ULM-101 meets this criteria at sampling rates of 32 and 64 kbps for input levels of 0 dBm and -13 dBm and at a sampling rate of 16 kbps for an input level of -13 dBm.

Table IV. Phase Jitter Measurement Summary

0 dBm Input								
Channel Number	CVSD Chan Rate				Log CVSD Chan Rate			
	8	16	32	64	8	16	32	64
1	+	+	11.4	9.6	+	+	11.8	9.4
2	+	+	12.1	9.5	+	+	12	9.4
3	+	+	12.4	11.4	+	+	12.3	11.1
4	+	+	12.4	12	+	+	12.3	9.5
-13 dBm Input								
1	+	11.4	4.3	3.1	+	11	4.8	3.0
2	+	11.7	5.7	2.8	+	11.9	5.5	2.8
3	+	13.4	5.7	3.9	+	13.2	5.1	3.1
4	+	13.1	5.2	3.0	+	12.6	5.4	2.9

+ = Phase Jitter greater than 25°.

3.1.7 Idle Channel Noise Test

3.1.7.1 Objective. The purpose of this test was to define the idle channel noise level of the ULM-101.

3.1.7.2 Procedure

3.1.7.2.1 The equipment interconnections for this test are identical to that shown in figure 22. The test was conducted in accordance with the instructions contained in the manual for the Hewlett-Packard Model 4940A Transmission Impairment Measuring Set (TIMS).

3.1.7.2.2 An idle channel noise measurement was performed for all four channel sampling rates and both coding techniques for all four active channels of the ULM-101. The test was conducted using both C-message and 3 kHz flat filters in the TIMS.

3.1.7.3 Results and Analysis

3.1.7.3.1 Table V contains a summary of the idle channel noise measurements performed on the ULM-101. The measurements are in terms of noise power, dBrnC for C-message filtering of the input and dBm for a 3 kHz flat filter. The conversion factor for translating the units into signal power units is $\text{dBm} = \text{dBrnC} - 90$. The wide bandwidth of the 3 kHz filter intercepts more of the noise resulting a 2 dB higher noise power reading.

3.1.7.3.2 A review of Table V shows that channel 1 of the ULM-101 has the best noise performance, approximately 3 dB better than the worst channel, channel 4. Table V shows that the noise level is identical for channel sampling rates of 8 and 16 kbps and again for sampling rates of 32 and 64 kbps. The noise level is 2-5 dB lower at 32 and 64 kbps sampling rates than at 8 and 16 kbps sampling rates. The noise level with CVSD coding is 2-4 dB higher than with the Log CVSD coding technique.

3.1.7.3.3 The noise level of a digital multiplexer is essentially determined by the granularity of the quantizing process, since the noise level of the analog circuitry is usually insignificant with respect to the smallest quantization level of the analog-to-digital converter.

3.1.7.3.4 Due to the fact that an analog-to-digital system has a noise floor which is dependent on the quantization, the circuit performance parameters of DCA Circular 300-175-0, Table II cannot be used for comparison. For example, the ULM-101 fails to meet the channel noise requirements for links up to 644 kilometers long, but meets the criteria for links between 644 and 2574 kilometers long.

Table V. Idle Channel Noise Measurement Summary

Channel Number	CVSD CODING							
	C-MSG Noise Power (dBrnC)				3kHz Noise Power (dBrn)			
	8	16	32	64	8	16	32	64
1	43	43	39	39	44	44	41	41
2	42	42	36	36	44	43	38	38
3	40	40	35	35	42	42	36	37
4	39+	39+	34	34	41	41	37	37
Log CVSD CODING								
1	39+	39+	38	38	41	41	39	39
2	37+	37+	33	33	39	39	35	35
3	33	33	31	31	34+	34+	33+	33+
4	37	37	32	32	39	39	36	36

3.1.8 Loop Test

3.1.8.1 Objective. The purpose of this test is to determine the number of times the ULM-101 can be looped at channel level without creating an unuseable link.

3.1.8.2 Procedure

3.1.8.2.1 The equipment interconnections for this test are shown in figure 23 for two loops at channel level. The transmit connection from the TMS provides a quiet 600 ohm termination for the CVSD #1 channel input. The receive input to the TMS is connected to the output of the last channel in the loop. An idle channel noise measurement is performed in this configuration. The idle channel noise measurement was chosen as the best indication of loop performance, the point where the system is noise limited.

3.1.8.2.2 The loop test was performed at all four sampling rates and both coding techniques for successive number of channel loopbacks of the ULM-101 up to the maximum number of seven. The test was conducted using C-message weighting in the TMS.

3.1.8.3 Results and Analysis

3.1.8.3.1 Figures 24 and 25 show the increase in idle channel noise with successive loopbacks for both CVSD and Log CVSD coding techniques with C-message weighting.

3.1.8.3.2 Figure 24 shows that for CVSD coding the noise generally increases as the number of loopbacks increases. Figure 25 reveals somewhat different behavior with Log CVSD coding. The trend of increasing noise with increasing number of loops is the same as for CVSD coding. The maximum level is lower than that with CVSD coding.

3.1.9 Signal-to-Quantizing Noise Ratio (S/N_q) Test

3.1.9.1 Objective. The purpose of this test was to determine the S/N_q ratio of the ULM-101 as a function of input level.

3.1.9.2 Procedure

3.1.9.2.1 The equipment configuration for this test is shown in figure 26. The audio oscillator output level was adjusted to provide a 0 dBm level at the input to the ULM-101 with the attenuation set to 0 dBm. Then the attenuator was used to vary the input level to the multiplexer between the measurement limits of 0 dBm and -40 dBm. The audio oscillator was tuned to a frequency of 1010 Hz. The frequency selective voltmeter was tuned to the maximum of the output signal from the ULM-101 and a measurement of the level of this signal was made with

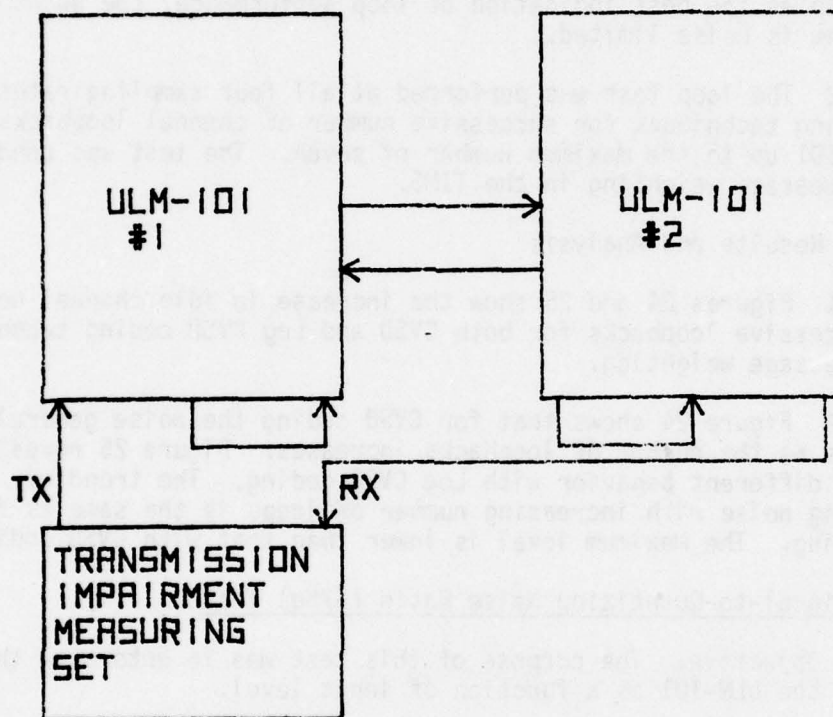

FIGURE 23. LOOPBACK TEST CONFIGURATION

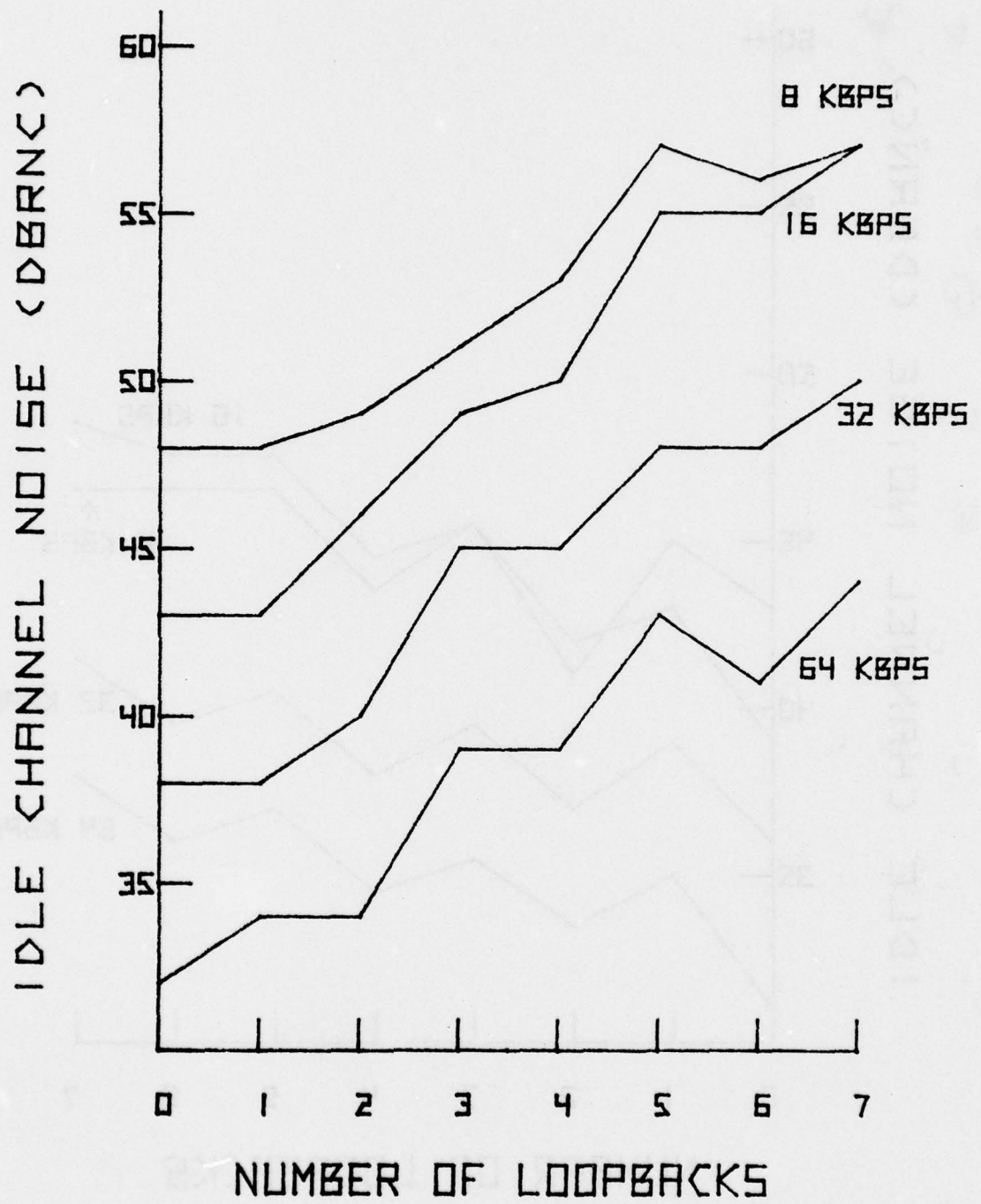

FIGURE 24. LOOP TEST RESULTS, (VSD)

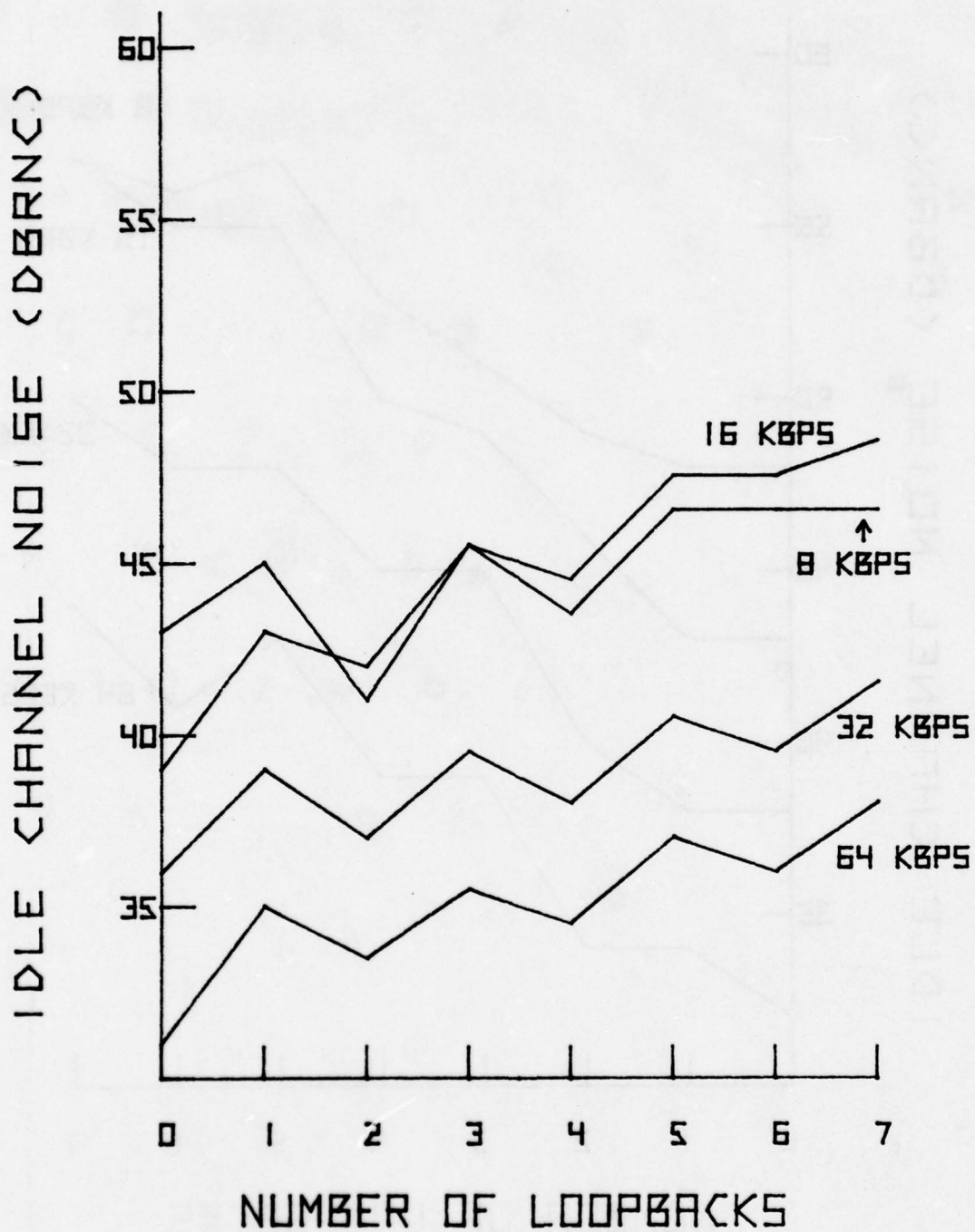

FIGURE 25. LOOP TEST RESULTS, LOGCVSD

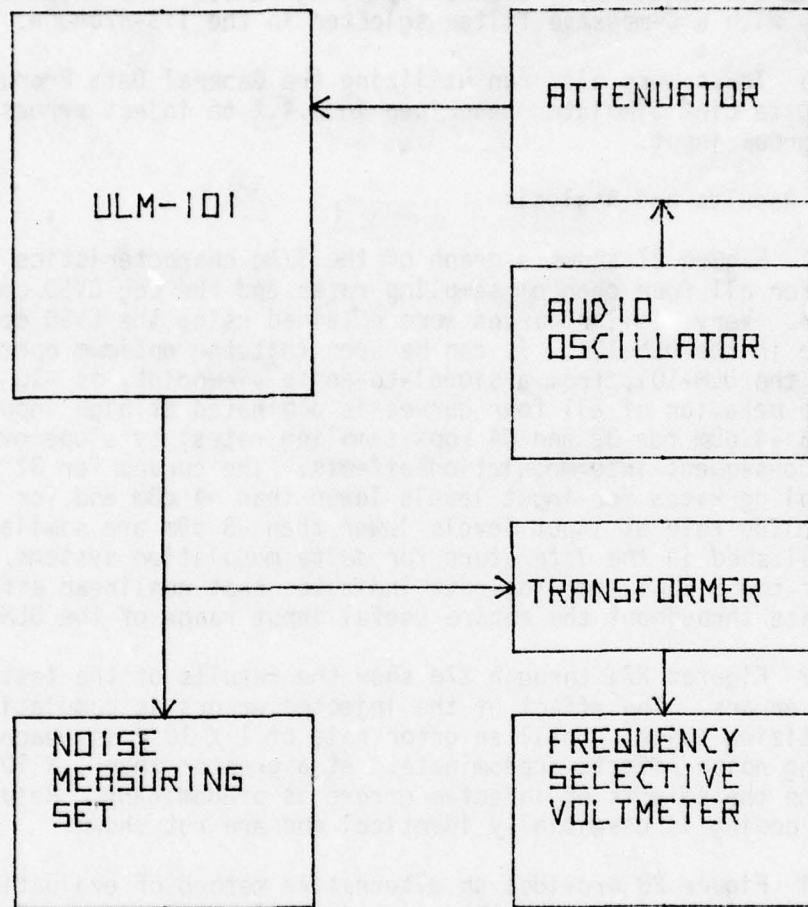

FIGURE 26. QUANTIZING NOISE CONFIGURATION

the voltmeter set to a 10 Hz measurement bandwidth. The noise measuring set used was a Northeast Electronic Model TTS-37BAQCN which contains a 1010 Hz notch filter to allow a measurement of noise power to be performed with the 1010 Hz input signal notched out. The TTS-37BAQCN has a measurement accuracy of +0.2 dB.

3.1.9.2.2 The S/Nq measurement was performed for both coding techniques and at all four channel sampling rates. The measurements were made with a C-message filter selected in the TTS-37BAQCN.

3.1.9.2.3 Tests were also run utilizing the General Data Products DLS-106 Data Link Simulator described in 3.4.1 to inject errors in the ULM-101 group input.

3.1.9.3 Results and Analysis

3.1.9.3.1 Figure 27 shows a graph of the S/Nq characteristics of the ULM-101 for all four channel sampling rates and the Log CVSD coding technique. Very similar curves were obtained using the CVSD coding technique in the ULM-101. It can be seen that the optimum operating range of the ULM-101, from a signal-to-noise viewpoint, is -10 to -20 dBm. The behavior of all four curves is dominated at high input levels (0 dBm to -4 dBm for 32 and 64 kbps sampling rates) by slope overload and the consequent intermodulation effects. The curves for 32 and 64 kbps sampling rates for input levels lower than -4 dBm and for a 16 kbps sampling rate at input levels lower than -8 dBm are similar to those published in the literature for delta modulation systems.² The curve for the 8 kbps sampling rate indicates that nonlinear effects predominate throughout the entire useful input range of the ULM-101.

3.1.9.3.2 Figures 27a through 27d show the results of the tests with injected errors. The effect of the injected errors is cumulative with the quantizing noise. Until an error rate of 1×10^{-3} is reached, quantizing noise effects predominate. At a greater than 1×10^{-3} error rate the effects of injected errors is predominant. Results with Log CVSD coding is essentially identical and are not shown.

3.1.9.3.3 Figure 28 provides an alternative method of evaluating the noise performance of the ULM-101 coding/decoding circuitry. This figure depicts the channel noise power as a function of the 1010 Hz test tone input signal power for channel sampling rates of 8 kbps and 64 kbps. The high level of the noise power and the essentially noise limited performance of the channel at an 8 kbps sampling rate are apparent from the figure. Alternatively, the curve of noise power for a 64 kbps channel rate decreases with decreasing level and in the range of -10 dBm to -20 dBm input level, decreases dB for dB with the input level, indicating linear, quieted operation in this range.

²Steele, "Delta Modulation Systems," John Wiley and Sons, New York (1975)

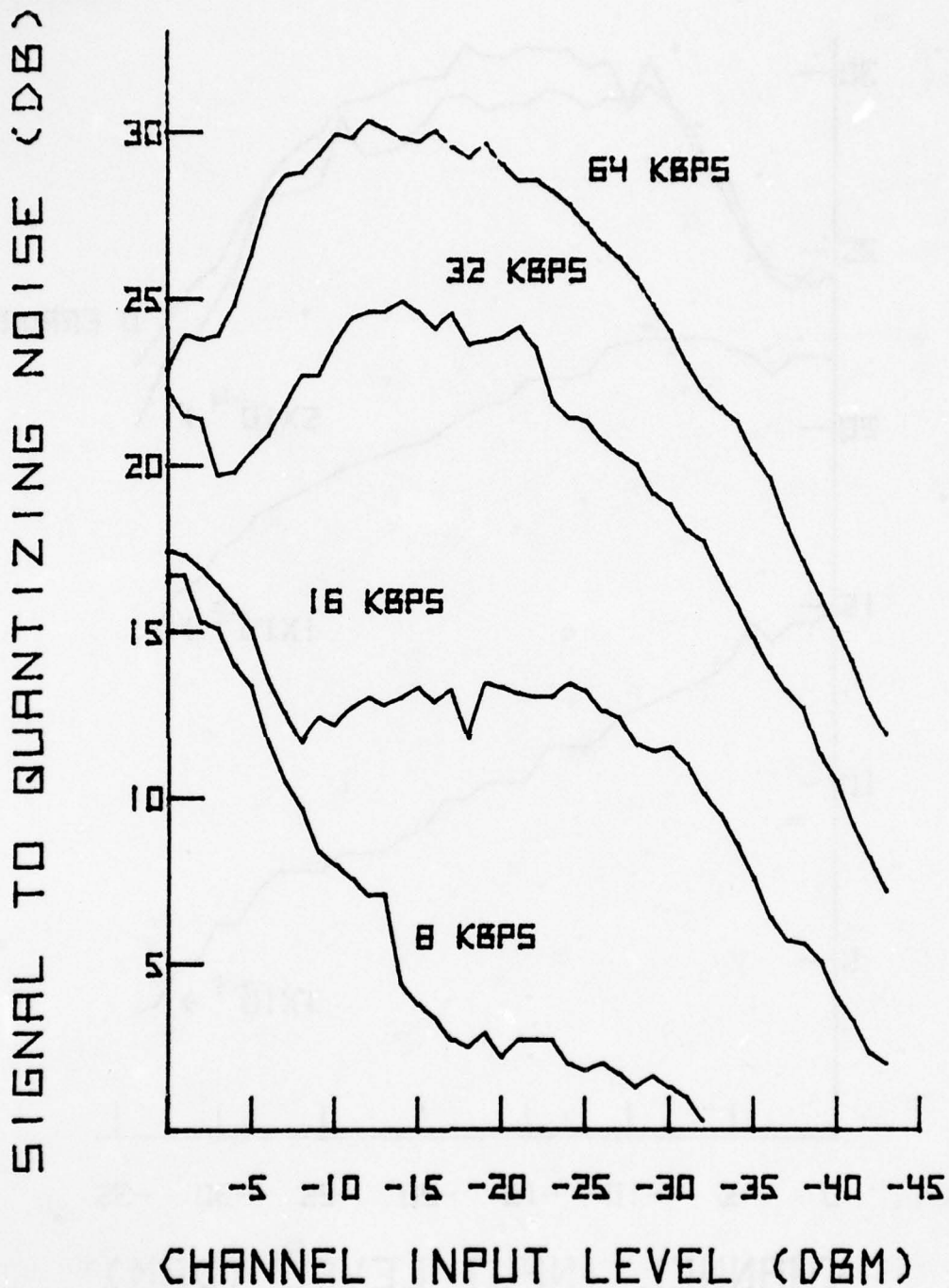

FIGURE 27. SIGNAL TO QUANTIZING NOISE CHARACTERISTICS

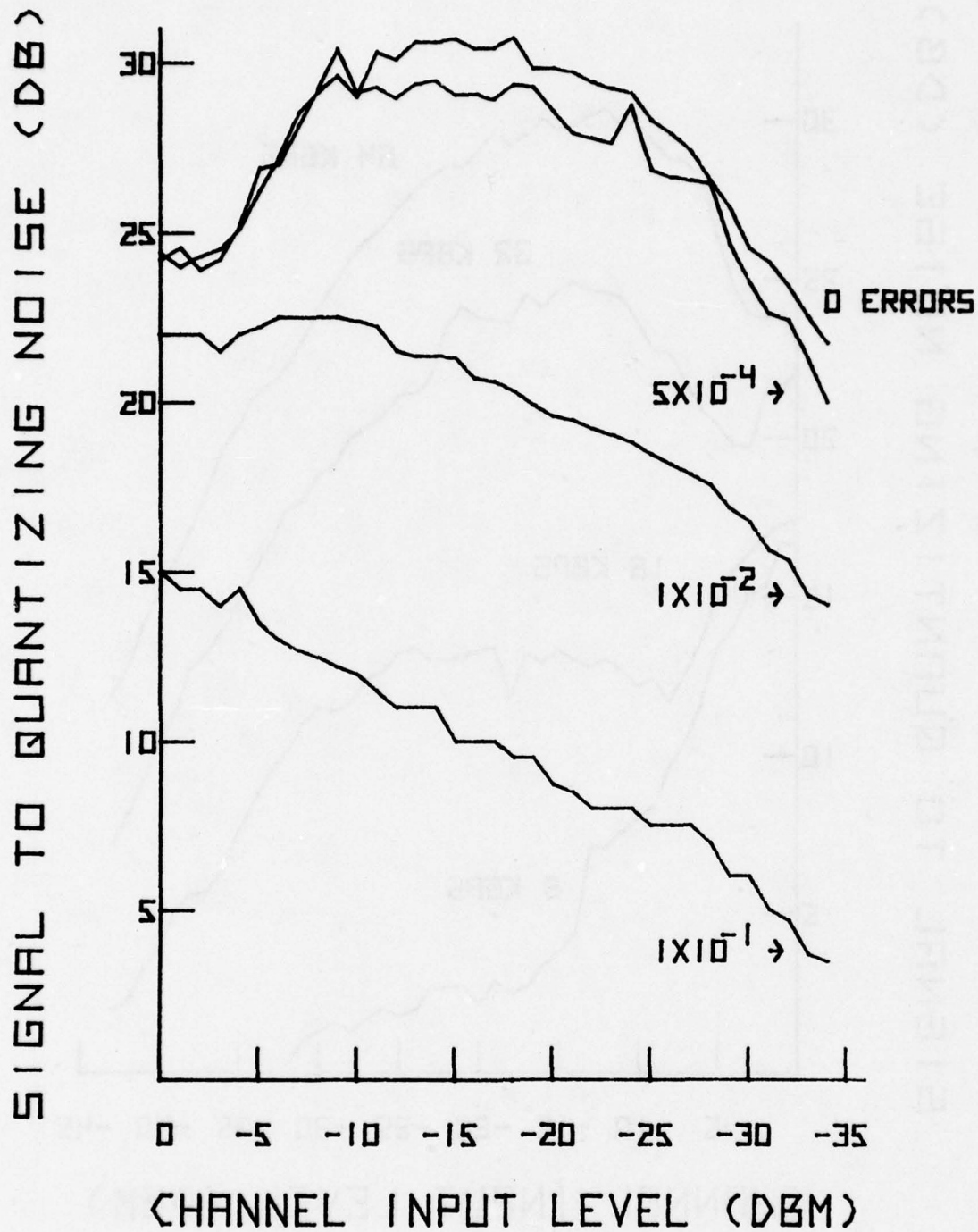

FIGURE 27A. SIGNAL TO QUANTIZING NOISE CHARACTERISTICS (64 KBPS)

SIGNAL TO QUANTIZING NOISE (DB)

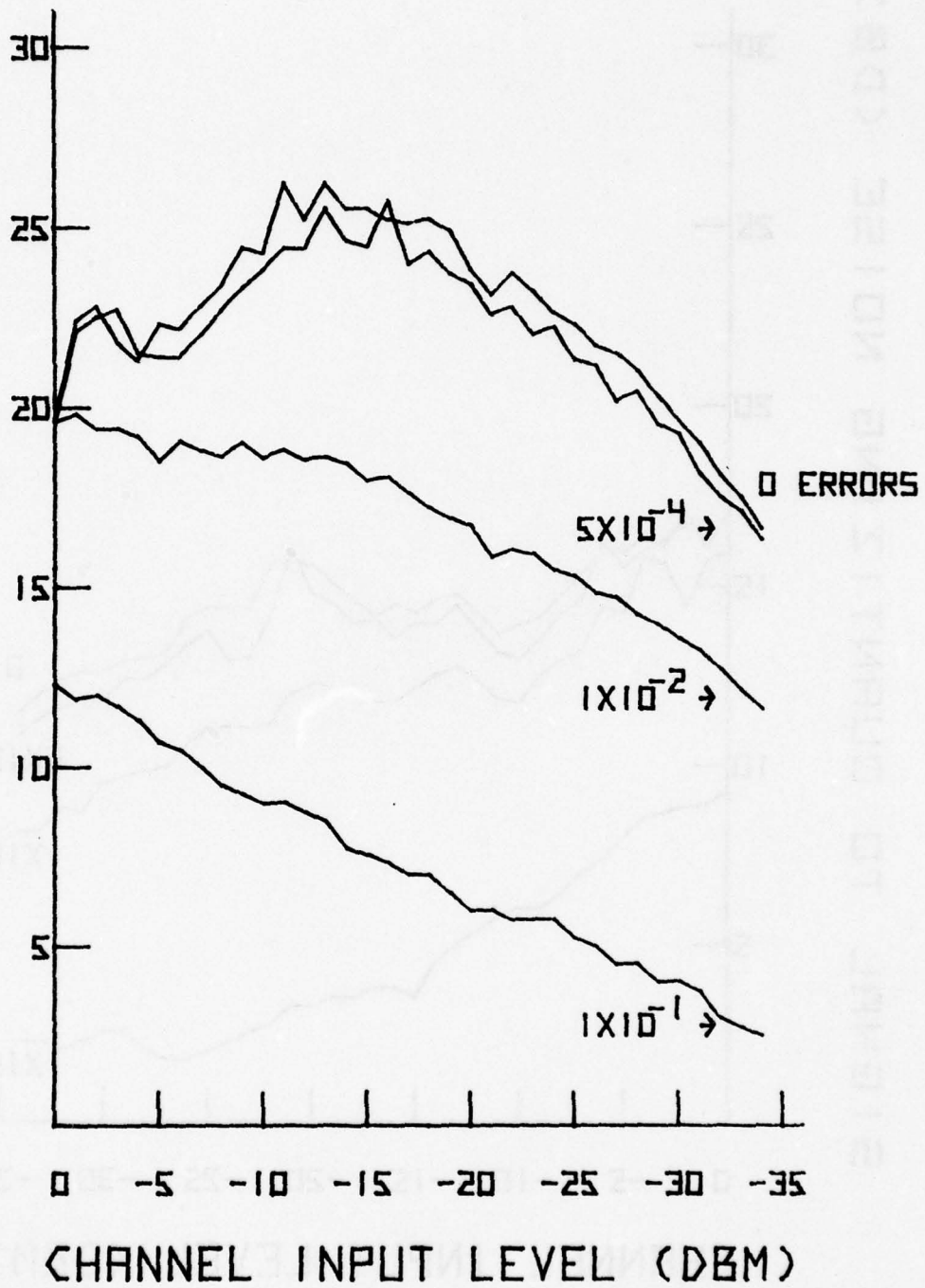

FIGURE 27B. SIGNAL TO QUANTIZING NOISE CHARACTERISTICS (32 KBPS)

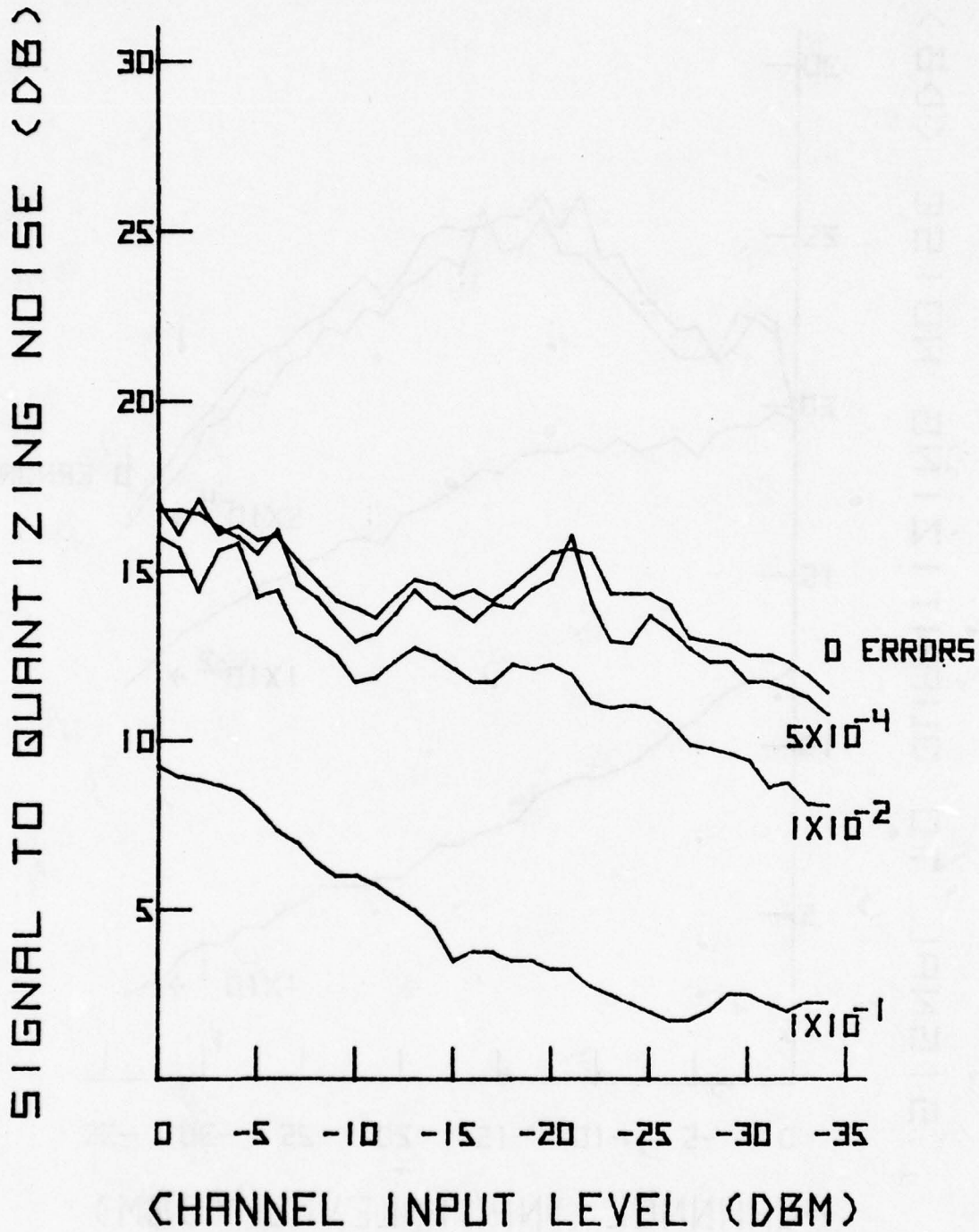

FIGURE 27C. SIGNAL TO QUANTIZING NOISE CHARACTERISTICS (16 KBPS)

SIGNAL TO QUANTIZING NOISE (DB)

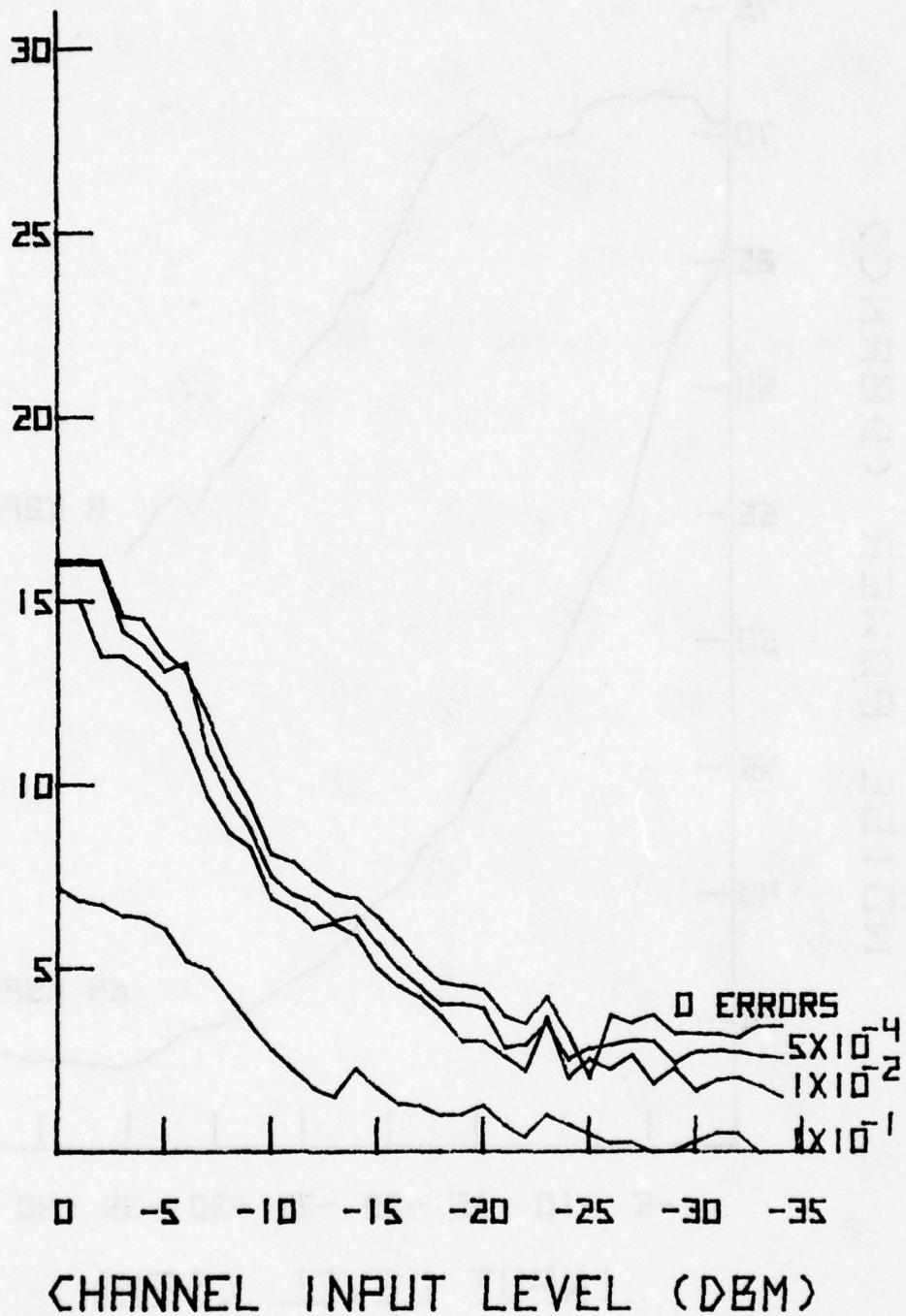

FIGURE 27D. SIGNAL TO QUANTIZING NOISE CHARACTERISTICS (8 KBPS)

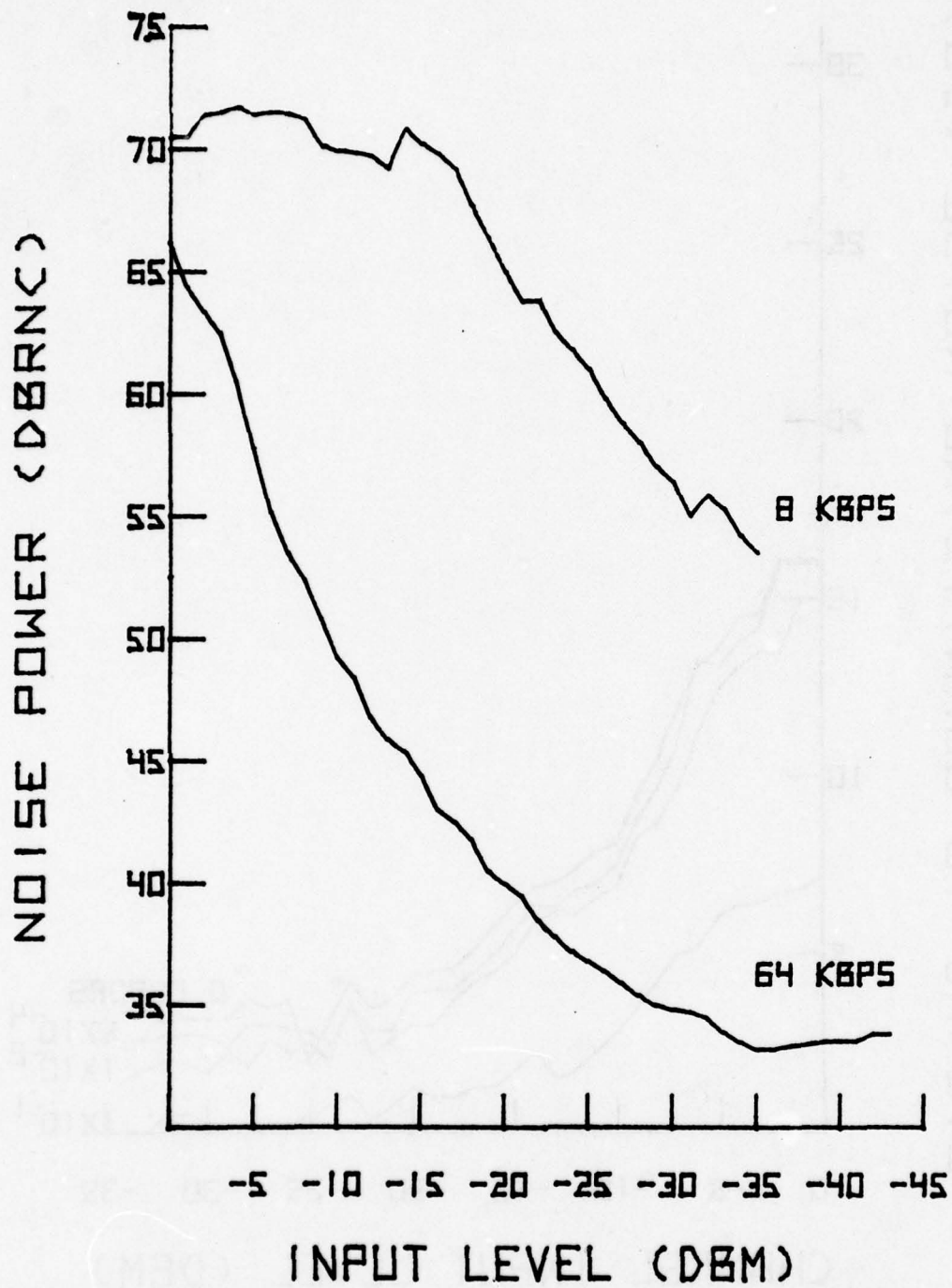

FIGURE 28. NOISE POWER VS INPUT LEVEL

3.1.10 Impulse Noise Test

3.1.10.1 Objective. The purpose of this test was to determine the impulse noise characteristics of the ULM-101.

3.1.10.2 Procedure

3.1.10.2.1 The equipment configuration for this test is the same as that shown in figure 22. The TIMS is configured to measure three parameters simultaneously: phase hits, gain hits, and noise impulses above threshold. The phase hit, gain hit and noise threshold are selected by individual controls on the front panel of the TIMS. Through an interaction within the TIMS circuitry, the phase hit and gain hit thresholds must be properly set (usually at high values) to obtain the proper reading of impulse noise hits above threshold. The low threshold for noise impulses was set, as much as possible, to a level which would give 5 to 15 counts in a 5 minute period. With the TIMS test set, the mid-threshold is then 4 dB higher than the low threshold and the high threshold is 8 dB higher than the low threshold. The C-message noise filter on the TIMS was used for this test.

3.1.10.2.2 The TIMS has switch selection of two different count rates: Bell Standard (limited to 7 counts per second) and Channel Limited (limited by noise bandwidth to 75 counts per second). The test was conducted using the channel limited setting as this provides data more consistent with digital performance.

3.1.10.2.3 The impulse noise test was conducted for all four channel sampling rates, both coding techniques and signal input levels of 0 dBm, -13 dBm, and -34 dBm. The TIMS uses a 1004 Hz signal as the test tone to perform this measurement.

3.1.10.3 Results and Analysis

3.1.10.3.1 Table VI summarizes the results of this test. It can be seen that roughly equivalent results were obtained for both coding techniques with perhaps slightly more sensitivity to impulse noise being shown with Log CVSD coding technique. The results of Table VI shows a decrease in the level of the low threshold noise power with a decrease in the input signal power as well as a decrease in the low threshold level with an increase in sampling rate. The 32 and 64 kbps sampling rates also show the effects of the slope overload (overload noise products predominant) at a 0 dBm input level.

3.1.10.3.2 Testing with the ULM-101 showed that a definite noise floor exists for the impulse noise counts. For example, a 72 dBmC low threshold level at 8 kbps sampling rate and -13 dBm input level results in continuous counts in all three categories. A one dB increase in the

Table VI. Impulse Noise Summary

		NOISE COUNTS			
		CVSD Code Technique			
Input Level (DBM)	Channel Rate (kbps)	Low Threshold Level (dBmC)	Low		
			Low	Mid	High
0dBm	8	64	22877	22668	9562
	16	72	20336	9683	2
	32	69	19558	13545	1
	64	69	17309	7026	7
-13 dBm	8	73	19835	9525	0
	16	64	21817	16495	10
	32	56	18018	6556	1
	64	51	17407	8893	15
-34 dBm	8	58	19779	12511	7
	16	51	15779	8908	30
	32	45	16200	6502	5
	64	40	17005	7539	6
		Log CVSD Code Technique			
0dBm	8	64	22873	22695	9562
	16	72	7361	6188	460
	32	69	19536	13653	84
	64	69	17036	6826	7
-13 dBm	8	73	19840	9535	0
	16	63	22086	18151	590
	32	56	18876	388	8
	64	51	17047	8039	13
-34 dBm	8	56	19893	2657	17
	16	50	15009	7046	3
	32	44	15162	4482	4
	64	40	17474	8776	20

level for the three counters results in zero counts in a five minute period in the HI counter.

3.1.10.3.3 The predominant factor in these impulse noise measurements is quantization noise. The low threshold level in each case is 4-8 dB below the level of quantization noise in the presence of a signal so the low and mid range counters are counting this noise. Once past the level of quantization noise the ULM-101 channel input circuitry is essentially quiet. The performance of the ULM-101 in a central office with normal "clicks", "pops", and "hisses" typical in those types of circuits would depend on the spectral distribution of the interference.

3.1.11 Nonlinear Distortion Test

3.1.11.1 Objective. The purpose of these tests was to determine the level of nonlinear distortion present in the analog output of the ULM-101.

3.1.11.2 Procedure

3.1.11.2.1 Two different equipment configurations were used for this test. The first configuration, which employs the HP-4940 TIMS, is identical to that shown on figure 22. In the nonlinear distortion test utilizing this configuration two tones, at 860 Hz and 1380 Hz, are simultaneously introduced into the ULM-101 channel input and the second and third order distortion products are measured. Second order distortion is represented by the power sum of $f_1 + f_2$ and $2f_2$ and $2f_1$ distortion products. Third order distortion is represented by the $2f_2 - f_1$ distortion product.

3.1.11.3.2 The second configuration used for this test is shown on figure 29. For this test, the audio oscillator was set to 1000 Hz and the frequency selective voltmeter was used to measure the signal present at 1000, 2000, 3000, 4000, and 5000 Hz. The measurement was made with the frequency selective voltmeter in the 10 Hz bandwidth position.

3.1.11.3.3 The two types of measurements of nonlinear distortion were performed for both coding techniques and at all four channel sampling rates of the ULM-101. Input levels of 0, -10, -13, and -16 dBm for the combined tones were used for the test.

3.1.11.3 Results and Analysis

3.1.11.3.1 Table VII shows the results of the nonlinear distortion measurements made with the TIMS. It can be seen that there is no significant difference between the results obtained with CVSD coding and those obtained using Log CVSD coding. At input levels of -10, -13, and -16 dBm for channel sampling rates of 8, 16, and 32 kbps, the level

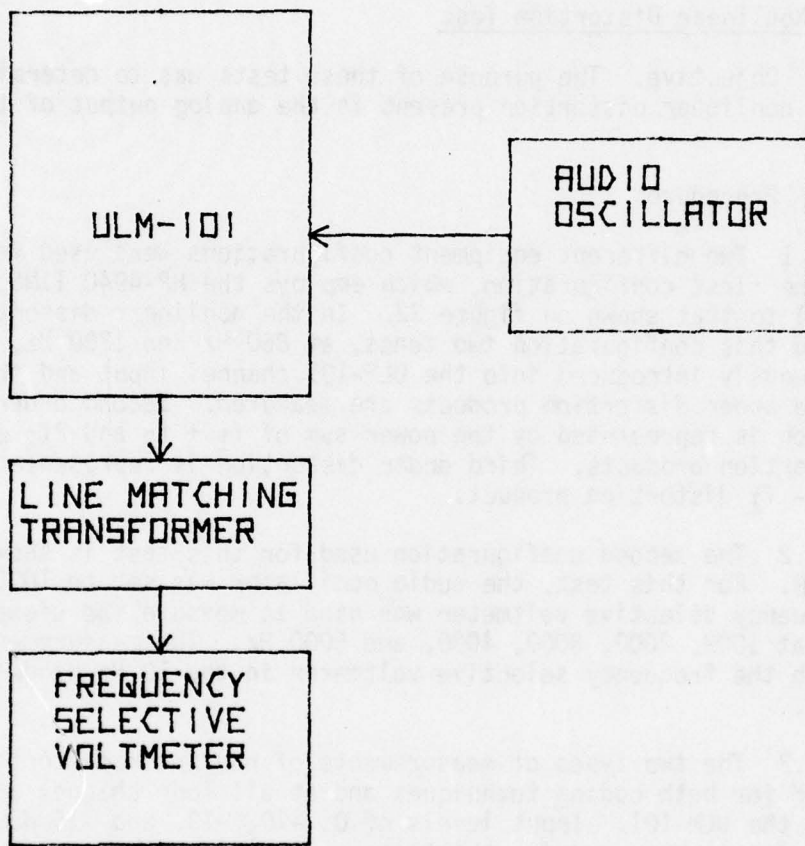

FIGURE 29. HARMONIC DISTORTION TEST CONFIGURATION

of the second order and third order products is approximately the same. With a sampling rate of 64 kbps at these input levels, the third order products are significantly lower than the second order products. At an input level of 0 dBm, the third order products are significantly higher than the second order products, and also higher than the third order products at lower input levels, again a result of slope overload effects.

3.1.11.3.2 Table VIII presents the results of the harmonic distortion measurements made with the frequency selective voltmeter. The measurement accuracy at low power levels is only +10 dB due to oscillations of the signal. With this consideration, there is no significant difference between the results with the two coding techniques at the lower input levels; the levels of all the harmonics for a particular channel sampling rate are approximately the same. The results for a 0 dBm input show the strong third harmonic at an 8 kbps sampling rate noted in the nonlinear distortion test. It will be noted that the level of the harmonics for the 8 kbps sampling rate remains reasonably constant as the input level decreases while the level of the harmonics for the other sampling rates decreases in level with input level down to -13 dBm and then remain relatively constant.

3.1.12 Three Frequency Intermodulation Distortion

3.1.12.1 Objective. The purpose of this test was to determine the level of intermodulation products present in a channel output of the ULM-101 with a channel input consisting of three equal level tones.

3.1.12.2 Procedure

3.1.12.2.1 The equipment configuration for this test is shown in figure 30. Three audio oscillators, tuned to frequencies of 860 Hz, 1380 Hz, and 1900 Hz, respectively, were resistively matched to provide a composite 600 ohm input to the ULM-101. The output levels of the three oscillators were equal and were adjusted to provide a total input signal power of 0 dBm and -13 dBm. The frequency selective voltmeter was used to measure the signal power at each of the second and third intermodulation distortion product frequencies.

3.1.12.2.2 The test was performed for both coding techniques and for all four sampling rates of the ULM-101. The results were recorded on oscilloscope photographs, X-Y plots, and readings with the frequency selective voltmeter.

3.1.12.3 Results and Analysis

3.1.12.3.1 There are 21 frequencies in the passband of the ULM-101 where second and third order intermodulation products can appear. The energy of these products is scattered throughout the passband and no

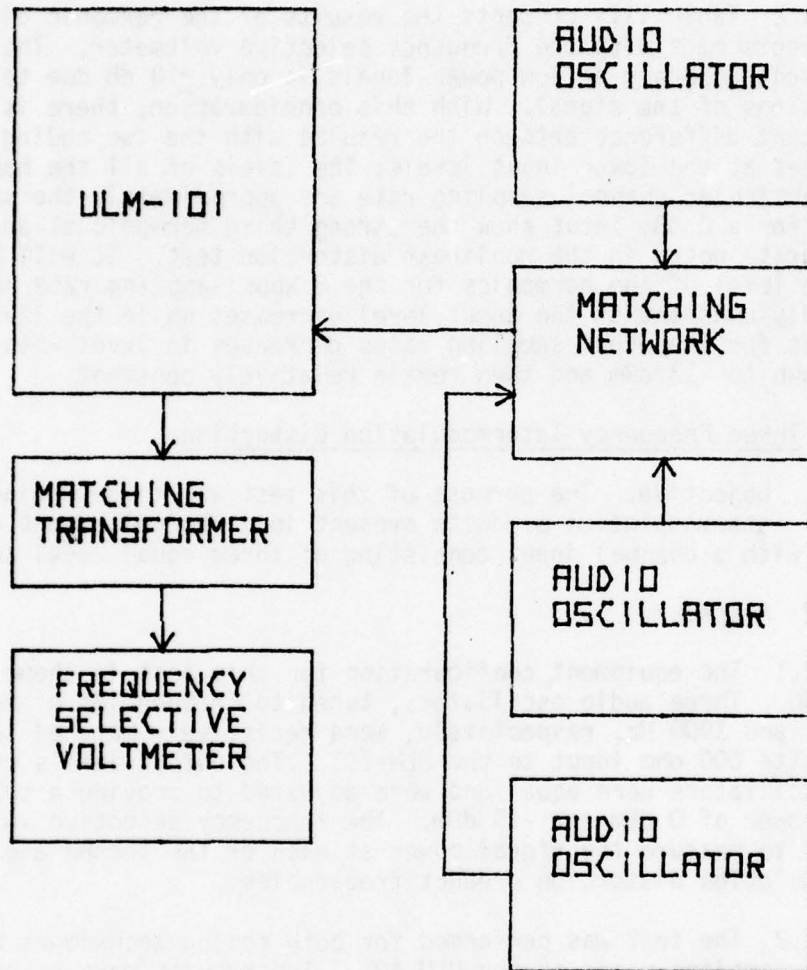

FIGURE 30. 3 FREQUENCY DISTORTION TEST CONFIGURATION

Table VII. Nonlinear Distortion Measurement Summary

INPUT LEVEL (dBm)	CHANNEL CODE TECHNIQUE	2nd Order Nonlinear Distortion (dB)			
		8 kbps	16 kbps	32 kbps	64 kbps
0	CVSD	25	32	28	24
	Log CVSD	26	32	29	24
-10	CVSD	26	28	30	27
	Log CVSD	26	28	30	27
-13	CVSD	22	27	32	29
	Log CVSD	22	29	32	29
-16	CVSD	21	29	34	32
	Log CVSD	20	29	33	31
		3rd Order Nonlinear Distortion (dB)			
0	CVSD	17	16	17	18
	Log CVSD	17	16	18	18
-10	CVSD	20	27	31	35
	Log CVSD	20	30	30	34
-13	CVSD	24	30	36	43
	Log CVSD	23	29	32	41
-16	CVSD	22	31	36	46
	Log CVSD	21	31	36	44

Table VIII. Harmonic Distortion Measurement Summary

Input Level (dBm)	Channel Code Technique	Channel Rate (kbps)	Harmonic Level (dBm)				
			1000 Hz (Fund)	2000 Hz	3000 Hz	4000 Hz	5000 Hz
0	CVSD	8	-3.7	-50	-23	-57	-35
		16	-2.6	-25	-29	-26	-43
		32	-2.8	-33	-29	-38	-35
		64	-2.5	-31	-37	-48	-43
	Log CVSD	8	-3.8	-50	-22	-57	-44
		16	-2.8	-25	-29	-26	-53
		32	-3.0	-34	-29	-44	-58
		64	-2.8	-31	-38	-50	-65
-10	CVSD	8	-12.7	-21.8	-32	-27	-43
		16	-12.5	-28.5	-40	-30	-47
		32	-12.4	-49	-44	-50	-52
		64	-12.2	-47	-51	-59	-70
	Log CVSD	8	-13.2	-23	-31	-27	-44
		16	-13.2	-33	-48	-48	-53
		32	-12.8	-50	-48	-54	-56
		64	-12.7	-47	-52	-57	-66
-13	CVSD	8	-12.7	-22	-31	-27	-43
		16	-15.5	-54	-45	-45	-42
		32	-15.4	-50	-48	-51	-45
		64	-15.2	-57	-55	-65	-60
	Log CVSD	8	-13.5	-23	-32	-27	-45
		16	-16	-51	-48	-29	-45
		32	-16	-48	-51	-58	-56
		64	-15.8	-51	-46	-64	-65
-16	CVSD	8	-17.5	-27	-31	-36	-34
		16	-18.5	-50.1	-51	-55	-60
		32	-18.4	-54	-48	-50	-60
		64	-18	-56	-58	-63	-60
	Log CVSD	8	-19	-28	-31	-33	-42
		16	-19	-38	-50	-48	-40
		32	-19	-55	-51	-54	-52
		64	-18.8	-55	-56	-65	-60

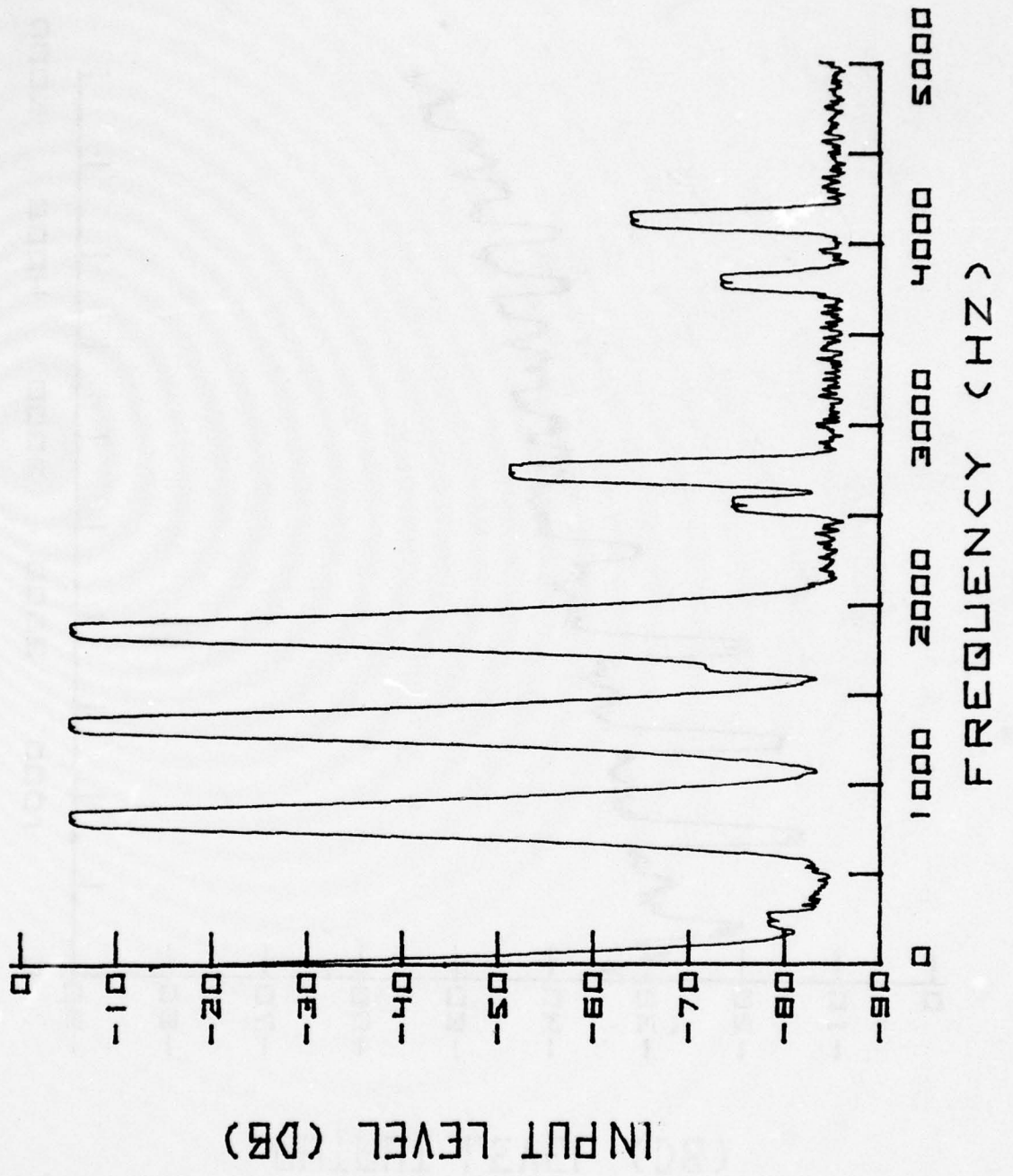

Figure 31.
 Three Frequency Intermodulation Input Spectrum

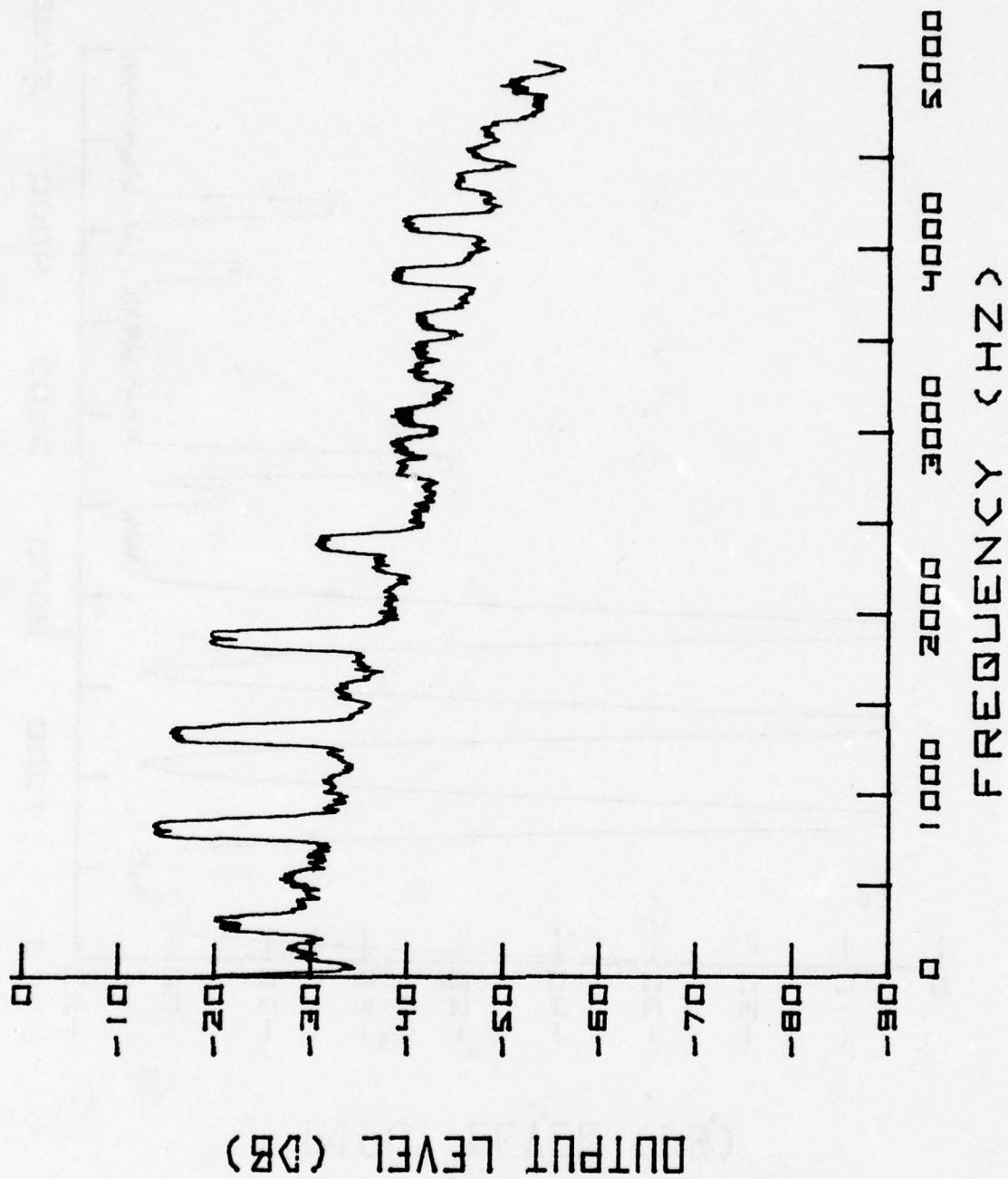

Figure 32.
 Three Frequency Intermodulation Test Results
 (8 kbps, 0 dBm)

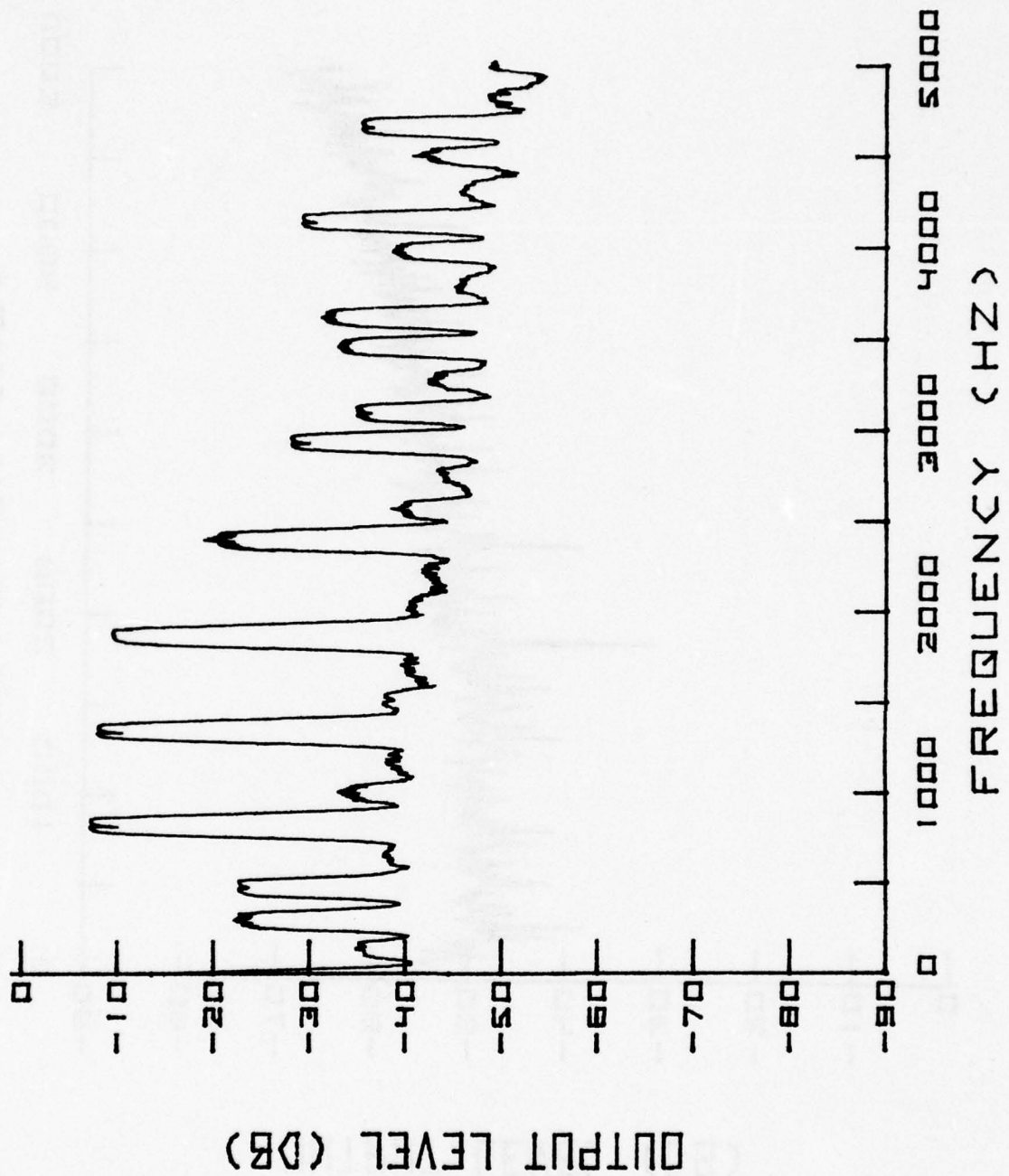

Figure 33.
 Three Frequency Intermodulation Test Results
 (64 kbps, 0 dBm)

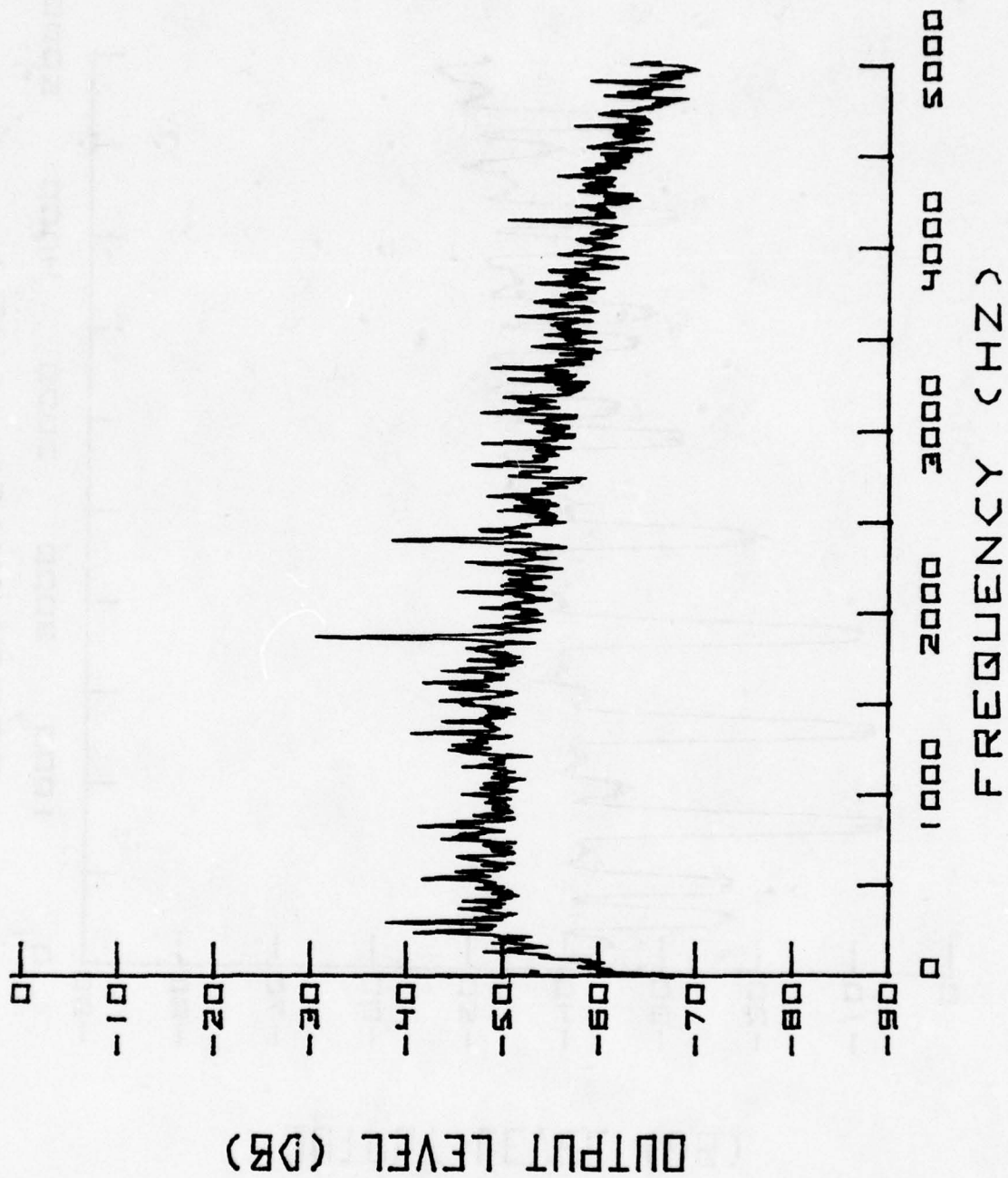

Figure 34.
 Three Frequency Intermodulation Test Results
 (8 kbps, -13 dBm)

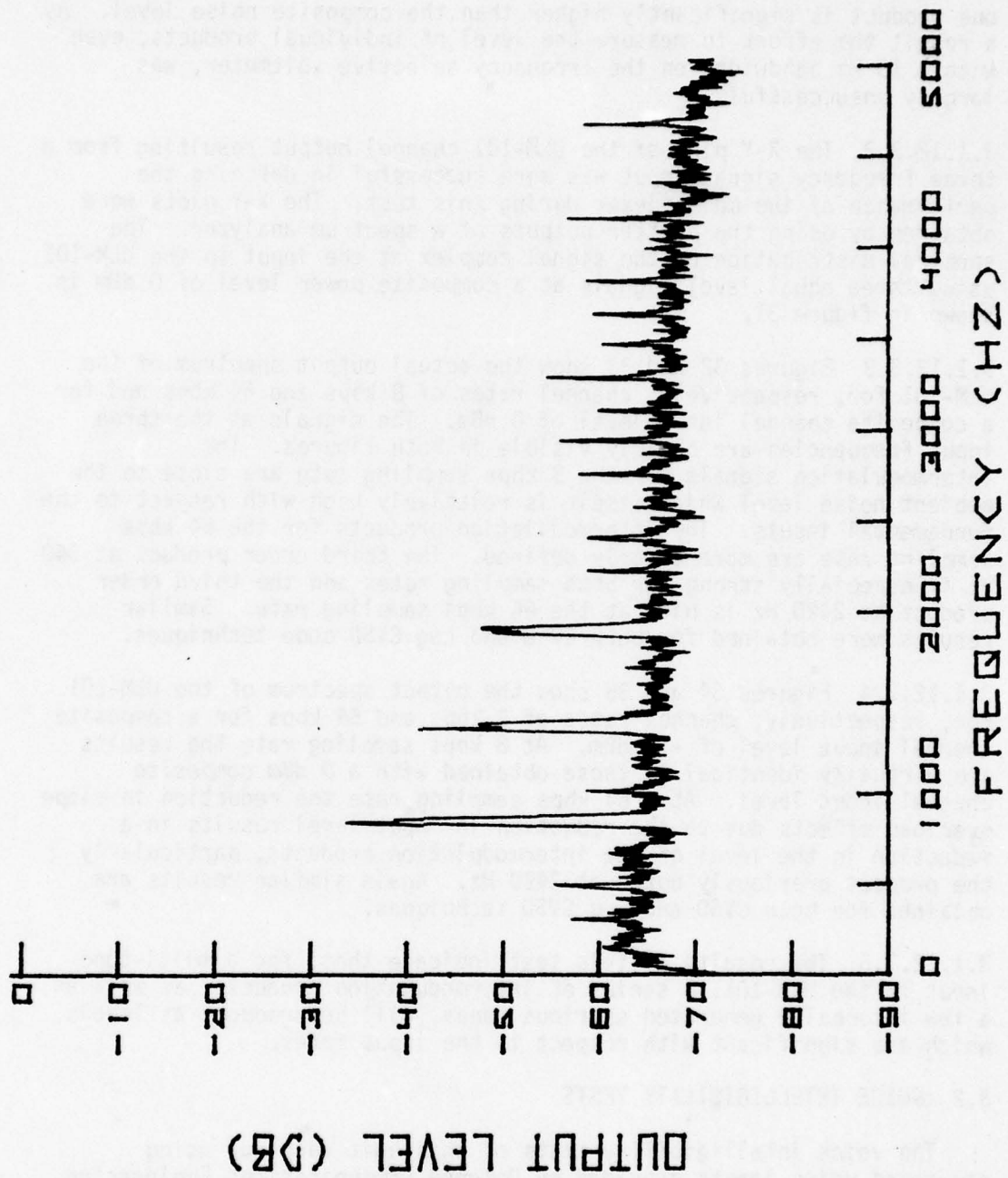

Figure 35.
 Three Frequency Intermodulation Test Results
 (64 kbps, -13 dBm)

one product is significantly higher than the composite noise level. As a result the effort to measure the level of individual products, even with a 10 Hz bandwidth on the frequency selective voltmeter, was largely unsuccessful.

3.1.12.3.2 The X-Y plot of the ULM-101 channel output resulting from a three frequency signal input was more successful in defining the performance of the multiplexer during this test. The X-Y plots were obtained by using the plotter outputs of a spectrum analyzer. The spectral distribution of the signal complex at the input to the ULM-101 using three equal level signals at a composite power level of 0 dBm is shown in figure 31.

3.1.12.3.3 Figures 32 and 33 show the actual output spectrum of the ULM-101 for, respectively, channel rates of 8 kbps and 64 kbps and for a composite channel input level of 0 dBm. The signals at the three input frequencies are clearly visible in both figures. The intermodulation signals for the 8 kbps sampling rate are close to the ambient noise level which itself is relatively high with respect to the fundamental inputs. The intermodulation products for the 64 kbps sampling rate are more clearly defined. The third order product at 340 Hz is especially strong for both sampling rates and the third order product at 2420 Hz is high at the 64 kbps sampling rate. Similar results were obtained for both CVSD and Log CVSD code techniques.

3.1.12.3.4 Figures 34 and 35 show the output spectrum of the ULM-101 for, respectively, channel rates of 8 kbps and 64 kbps for a composite channel input level of -13 dBm. At 8 kbps sampling rate the results are virtually identical to those obtained with a 0 dBm composite channel input level. At a 64 kbps sampling rate the reduction in slope overload effects due to the reduction in input level results in a reduction in the level of the intermodulation products, particularly the product previously noted at 2420 Hz. Again similar results are obtained for both CVSD and Log CVSD techniques.

3.1.12.3.5 The results of this test indicate that, for a multi-tone input to the ULM-101, a series of intermodulation products, as well as a few internally generated spurious tones, will be produced at levels which are significant with respect to the input tones.

3.2 VOICE INTELLIGIBILITY TESTS

The voice intelligibility tests of this unit were run using pre-taped voice inputs provided by Defense Communications Engineering Center (DCEC). The output of the ULM-101 was recorded and these tapes provided to DCEC for rating. Results of test are expected to be published by DCEC.

3.3 QUASI-ANALOG SIGNAL TESTS

3.3.1 General

3.3.1.1 Objective. The purpose of the quasi-analog signal tests was to determine the ability of the ULM-101 to process the output signals of digital data modems and a Voice Frequency Carrier Telegraph (VFCT). The ULM-101 is to pass these signals without creating unacceptable performance degradation in the equipment.

3.3.1.2 Procedure

3.3.1.2.1 The equipment configuration is as shown in figure 36. The interface between the quasi analog signal source and the test equipment used to produce input digital data (HP 1645A Data Error Analyzer) is a RS-232C interface.

3.3.1.2.2 The digital data modem is set to operate on internal timing; the modem transmit clock is used to provide a clock signal to the HP-1645A, which operates in external clock. The HP-1645A outputs data at the modem clock rate in a pseudo-random pattern 2047 bits long. The received data pattern is compared to the transmitted pattern and each mis-compare results in an error pulse output. The error pulse outputs are counted, the sampling time period is set, and at the end of each sampling period, the total number of errors is printed by a digital printer. The period used to sample for errors is dependent on the error rate. At high error rates, sampling is conducted for a period long enough to measure 50-100 errors. As the number of errors decreases, the sample period is increased, up to 600 seconds. Five measurement sequences are made for each test configuration; the statistical mean of the five readings is used as the representative number of errors for that configuration. If no errors are obtained during the initial 600-second sample period, a single 6000-second measurement is made and recorded as the error performance for that test configuration. If no errors are obtained during a 6000 second period, the error rate is calculated assuming 1 error during that period and recorded as being less than this error rate. Occasionally during the test measurements were also made overnight for a 57,600 second period.

3.3.1.2.3 The Voice Frequency (VF) output of the data modem is wired to a patch panel, as are the analog inputs and outputs of the four active channels of both of the ULM-101 multiplexers. The cable receive and transmit signals of the two multiplexers are interconnected as shown in figure 36 to allow multiple looping at channel level to be accomplished. The VF signal from the data modem is connected from the output of one channel to the input to the the next channel the necessary number of times to create the desired loopback configuration; the maximum number of loopbacks is seven. Tests were performed with 0 to 7 loopbacks unless otherwise noted.

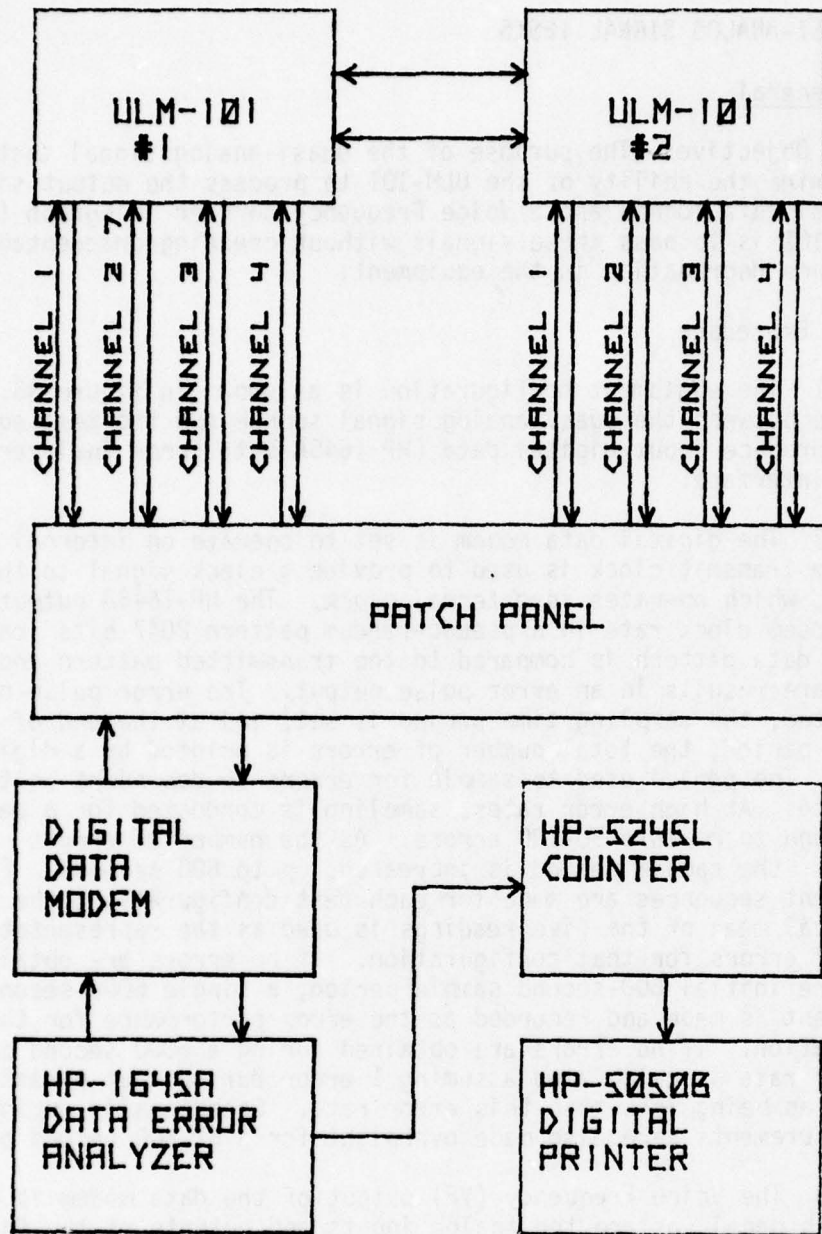

FIGURE 36. QUASI-ANALOG SIGNAL TEST CONFIGURATION

3.3.1.2.4 Both coding techniques and all four sampling rates of the ULM-101 were utilized.

3.3.2 Voice Frequency Carrier Telegraph, AN/FCC-19 Test

3.3.2.1 Procedure. For this test, the general procedure of 3.3.1 was modified to use a Data-Tek 9600 to originate a test message and provide this message as a dry contact keyer to one channel of the AN/FCC-19. Fourteen of the remaining 15 channels of the AN/FCC-19 were looped together and loaded with the dotter (r-y) output of the AN/FCC-19. The remaining channel was inoperative. The output of the AN/FCC-19 channel under test was connected back to the Data-Tek 9600 to allow measurement of errors and distortion to be made. The center frequencies of the AN/FCC-19 channels tested were 425, 1275, and 2975 Hz and the AN/FCC-19 was operating at 100 words per minute.

3.3.2.2 Results and Analysis

3.3.2.2.1 Table IX shows the results of the measurements made for a single loop through the ULM-101. The error counts were accumulated over a two minute time period in each case.

3.3.2.2.2 It can be seen from a review of Table IX that approximately the same results were obtained for CVSD and Log CVSD coding techniques. At 8 and 16 kbps sampling rates, the number of errors was lower for a center frequency of 1275 Hz than for either of the other center frequencies. In general, the distortion increased with an increase in center frequency. At 32 and 64 kbps, the number of errors was approximately the same for all three center frequencies.

3.3.2.2.3 The results of this test show that the AN/FCC-19 would be unuseable with the ULM-101 for sampling rates of 8 kbps and 16 kbps.

3.3.2.2.4 Table X shows the results of the measurements made on the AN/FCC-19 for successive number of loopbacks at channel level through the ULM-101. Only sampling rates of 32 and 64 kbps are shown since sampling rates of 8 and 16 kbps result in maximum readings of errors and distortion. Similar results were obtained for CVSD and Log CVSD coding techniques so only the CVSD coding results are shown. At four loopbacks through the ULM-101 the AN/FCC-19 ceased to function for any sampling rate.

3.3.2.2.5 As can be seen from a review of Table X, the number of errors and amount of distortion increases with increasing numbers of loopbacks. The number of errors observed using the 1275 Hz center frequency channel are consistently smaller than either of the other center frequencies.

3.3.2.2.6 The results of Table X indicate that even one loopback at channel level of the ULM-101 results in an increase in errors and distortion which would result in unuseable operation of the AN/FCC-19 in most cases. It is possible that, using a center frequency of 1275 Hz and a ULM-101 sampling rate of 64 kbps, message traffic could be passed but it would be of extremely marginal quality.

3.3.3 Telephone Modem, MD-775/GCC Test

3.3.3.1 Procedure. The tests were performed with modem input rates of 150, 300, 600, 1200 and 2400 baud. The modem utilizes QPSK modulation with a carrier frequency of 1800 Hz.

3.3.3.2 Results and Analysis

3.3.3.2.1 Results of this test are shown in Table XI. The 8 kbps channel sampling rate is not shown as the test set could not achieve lock at zero loopbacks; therefore, the ULM-101 is not useable at 8 kbps with the MD-775. The average error rate for a 16 kbps channel sampling rate is sufficiently high to be considered unuseable at all baud rates of the MD-775. Error-free data could be obtained at all baud rates of the MD-775 at a ULM-101 channel sampling rate of 32 kbps with zero loopbacks. At one loopback, useable data could be obtained at only the 1200 and 2400 baud rates. With two loopbacks the data at 1200 and 2400 baud is marginal. At three or more loopbacks the ULM-101 is unuseable. At a 64 kbps channel sampling rate error free data was obtained with zero and one loopback. At two loops through the ULM-101, the data was marginal at MD-775 rates of 150, 300 and 600 baud and unuseable with more loops. Error free data was obtained with up to seven loopbacks with the 1200 and 2400 baud rates.

3.3.4 Low Speed Data Modem, MD-674(P)/G Test

3.3.4.1 Procedure. The MD-674(P)/G operates at 150, 300, 600 and 1200 bps using the MX-7374/G, MX-7375/G and MX-7379/G plug-in modems. The incoming data switches on line a mark oscillator or a space oscillator. The MX-7375/G uses 680 Hz for a mark and 1360 Hz for a space. The MX-7379/G uses 1200 Hz for a mark and 2400 Hz for a space. The MX-7374/G uses 765 Hz for a mark and 935 Hz for a space.

3.3.4.2 Results and Analysis

3.3.4.2.1 Table XII shows the results for this test. With the MX-7374/G modem subassembly which operates at an 150 bps rate, error free data was obtained for all channel sampling rates with zero or one loopback. With a channel sampling rate of 8 kbps system performance started to degrade at two loopbacks with unuseable data obtained after three loopbacks. With a channel sampling rate of 16 kbps useable data was passed with seven loopbacks. With 32 and 64 kbps sampling the MX-7374/G modem subassembly data was passed error free.

Table IX. VFCT Test Results

AN/FCC-19 Channel Center Frequency	Channel Rate (kbps)	Channel Code Technique			
		CVSD		Log CVSD	
		Average Error Rate	Distortion (%)	Average Error Rate	Distortion (%)
425 Hz	8	3.74×10^{-2}	24	4.22×10^{-2}	24
	16	1.01×10^{-2}	22	9.89×10^{-3}	10
	32	2.22×10^{-4}	14	2.22×10^{-4}	14
	64	1.11×10^{-4}	10	* 1.11×10^{-4}	14
1275 Hz	8	5.27×10^{-2}	28	2.97×10^{-2}	24
	16	6.33×10^{-3}	20	4.22×10^{-3}	14
	32	2.22×10^{-4}	16	1.11×10^{-4}	14
	64	* 1.11×10^{-4}	14	* 1.11×10^{-4}	14
2975 Hz	8	3.99×10^{-2}	30	3.83×10^{-2}	29
	16	1.12×10^{-2}	28	1.07×10^{-2}	24
	32	3.33×10^{-4}	32	5.56×10^{-4}	20
	64	* 1.11×10^{-4}	16	* 1.11×10^{-4}	16

* Less than value shown (no errors occurred)

Table X. VFCT Test Results (ULM-101 Loop Backs)

AN/FCC-19 Center Frequency	Number of Loop Backs	Channel Rate (kbps)			
		32		64	
		Average Error Rate	Distortion (%)	Average Error Rate	Distortion (%)
425 Hz	0	2.2×10^{-4}	14	1.11×10^{-4}	10
	1	1.64×10^{-2}	22	9.78×10^{-3}	22
	2	2.07×10^{-2}	22	1.48×10^{-2}	24
	3	2.47×10^{-2}	26	2.41×10^{-2}	24
1275 Hz	0	2.2×10^{-4}	16	* 1.11×10^{-4}	14
	1	4.89×10^{-3}	20	2.44×10^{-3}	18
	2	8.67×10^{-3}	21	3.89×10^{-3}	18
	3	1.38×10^{-2}	22	6×10^{-3}	19
2975 Hz	0	3.33×10^{-4}	22	* 1.11×10^{-4}	16
	1	2.42×10^{-2}	22	1.42×10^{-2}	22
	2	3.99×10^{-2}	28	3.18×10^{-2}	28
	3	3.54×10^{-2}	30	4.17×10^{-2}	30

* Less than value shown (no errors occurred)

Table XI MD-775/GCC Test Results (ULM-101 Loopbacks)

Channel Rate	Number of Loopbacks	Average Error Rate of Input Rates				
		150	300	600	1200	2400
16 kbps	0	4.1×10^{-2}	3.7×10^{-2}	1.7×10^{-2}	2.0×10^{-3}	2.7×10^{-3}
	1	6.4×10^{-2}	5.2×10^{-2}	**	2.3×10^{-2}	**
	2	**	**	**	**	**
32 kbps	0	$*4 \times 10^{-6}$	$*2 \times 10^{-6}$	$*1 \times 10^{-6}$	$*5 \times 10^{-7}$	$*2.5 \times 10^{-7}$
	1	7.5×10^{-4}	5.9×10^{-3}	1.6×10^{-3}	3.9×10^{-6}	2.7×10^{-5}
	2	1.9×10^{-2}	2.2×10^{-2}	1.6×10^{-2}	3.7×10^{-4}	9.1×10^{-4}
	3	**	**	**	6.3×10^{-3}	5.3×10^{-3}
	4	**	**	**	1.8×10^{-2}	9.5×10^{-3}
	5	**	**	**	2.1×10^{-2}	1.9×10^{-2}
	6	**	**	**	**	**
64 kbps	0	$*4 \times 10^{-6}$	$*2 \times 10^{-6}$	$*1 \times 10^{-6}$	$*5 \times 10^{-7}$	$*2.7 \times 10^{-7}$
	1	$*4 \times 10^{-6}$	$*2 \times 10^{-6}$	$*1 \times 10^{-6}$	$*5 \times 10^{-7}$	$*2.7 \times 10^{-7}$
	2	5.6×10^{-5}	$*2 \times 10^{-6}$	2×10^{-5}	$*5 \times 10^{-7}$	$*2.7 \times 10^{-7}$
	3	6.9×10^{-4}	1.8×10^{-3}	6.4×10^{-4}	$*5 \times 10^{-7}$	$*2.7 \times 10^{-7}$
	4	**	**	**	$*5 \times 10^{-7}$	$*2.7 \times 10^{-7}$
	5				$*5 \times 10^{-7}$	$*2.7 \times 10^{-7}$
	6				$*5 \times 10^{-7}$	$*2.7 \times 10^{-7}$

* Less than value shown

** Test set out of lock

3.3.4.2.2 With the MX-7375/G modem subassembly which operates at 300 and 600 bps, error free data was passed for up to seven loopbacks when the ULM-101 channel sampling rates of 32 and 64 kbps were used. At a ULM-101 channel sampling rate of 8 kbps, no useable data could be passed. At a 16 kbps ULM-101 rate error free data was passed at zero loopbacks. At one loopback the error rate (on the order of 10^{-4}) was high enough to be objectionable. At three loopbacks the error rate was sufficient to prohibit the test set from acquiring lock.

3.3.4.2.3 With the MX-7379/G modem subassembly which operates at 150, 300, 600 and 1200 bps, error free data was passed for all input rates and ULM-101 channel sampling rates of 16, 32 and 64 kbps without loopbacks. No useable data could be obtained for a ULM-101 rate of 8 kbps regardless of modem input rate. After 1 loopback, data passed with a 16 kbps ULM-101 rate was marginal for all modem input rates. With ULM-101 rates of 32 and 64 kbps the quality of data passed was dependent on the modem input rate as shown in Table XII, Part 3.

3.3.5 Digital Data Modem, Lenkurt 261A Test

3.3.5.1 Procedure. The Lenkurt 261A was used in place of the MD-701. The 261A is electrically equivalent to the MD-701 which was not available. The 261A uses a duobinary technique in which signal transitions are synchronized with shift frequency transitions; 2400 bps data occupies the same bandwidth with duobinary coding as 1200 bps FM or FSK data does. There is, however, a 3 dB noise penalty with respect to the 1200 bps binary FM.

3.3.5.2 Results and Analysis

3.3.5.2.1 Results are shown in Table XIII. At a ULM-101 channel sampling rate of 8 kbps the error rate was too great to allow the test set to achieve lock and the 261A was not useable with the ULM-101. At 16 kbps the test set could achieve lock but the data passed is unuseable. At 32 kbps, error free data was passed when no loopbacks were used but with more than one loopback the quality of data passed was unacceptable. At 64 kbps, error free data was passed with up to two loopbacks and data quality degraded with increasing numbers of loopbacks until, with seven loopbacks, it was unacceptable.

3.3.6 SF Signaling Test

3.3.6.1 Objective. The purpose of this test is to determine the ability of the ULM-101 to pass SF signaling at various pulse rates and input levels.

3.3.6.2 Procedure

3.3.6.2.1 The equipment configuration for this test is shown in figure 37. The Northeast Electronics TTS-26B pulse signaling test set and

Table XII. Part 1 - MD-674(P)/G Test Results

Channel Sample Rate	Number of Loopbacks	MX-7374/G Modem Subassembly	
		Average Error Rate	
8 kbps	0-1	$*4.2 \times 10^{-6}$	
	2	8.9×10^{-6}	
	3	3.2×10^{-3}	
	4	8.3×10^{-3}	
	5	2.1×10^{-2}	
	6	2.7×10^{-2}	
	7	4×10^{-2}	
16 kbps	0-5	$*4.2 \times 10^{-6}$	
	6	4.4×10^{-6}	
	7	4.9×10^{-5}	
32 kbps	0-7	$*4.2 \times 10^{-6}$	
64 kbps	0-7	$*4.2 \times 10^{-6}$	

* Less than value shown (0 error occurred)

Table XII. Part 2 - MD-674(P)/G Test Results

Channel Sampling Rate	Number of Loopbacks	MX-7375/G Modem Subassembly	
		Average Error Rate	
		Input Rate 300	600
8 kbps	0	3.7×10^{-3}	**
	1	**	
16 kbps	0	$*2.1 \times 10^{-6}$	$*1.06 \times 10^{-6}$
	1	1.3×10^{-4}	1.5×10^{-4}
	2	6.6×10^{-4}	**
	3	**	**
32 kbps	7	$*2.1 \times 10^{-6}$	$*1.06 \times 10^{-6}$
64 kbps	7	$*2.1 \times 10^{-6}$	$*1.06 \times 10^{-6}$

* Less than value shown - no error occurred

** Test set out of lock (total crash)

Table XII - Part 3 MD-674(P)/G Test Results

Channel Sampling Rate	Number of Loopbacks	MX-7375/G Modem Subassembly Average Error Rate			
		Input Rate 150 Baud	300	1200	600
16 kbps	0	*4.2x10 ⁻⁶	*2.11x10 ⁻⁶	*5.28x10 ⁻⁷	1.05x10 ⁻⁶
	1	3.7x10 ⁻³	3.67x10 ⁻³	5.3x10 ⁻⁴	9x10 ⁻⁴
	2	5.2x10 ⁻³	5.11x10 ⁻³	**	**
	3	4x10 ⁻²	**	**	**
	4-7	**	**	**	**
32 kbps	0	*4.2x10 ⁻⁶	*5.6x10 ⁻⁷	*5.3x10 ⁻⁷	*1x10 ⁻⁶
	1	*4.2x10 ⁻⁶	*5.6x10 ⁻⁷	*5.3x10 ⁻⁷	9.3x10 ⁻⁸
	2	1.1x10 ⁻⁴	*5.6x10 ⁻⁷	1.7x10 ⁻⁴	6.5x10 ⁻⁵
	3	3.6x10 ⁻⁴	*5.6x10 ⁻⁷	1.4x10 ⁻³	6.9x10 ⁻⁴
	4	6.4x10 ⁻⁴	7.8x10 ⁻⁶	**	**
	5	2.3x10 ⁻³	4x10 ⁻⁵	**	**
	6	5.9x10 ⁻³	**	**	**
	7	**	**	**	**
64 kbps	0-2			*5.28x10 ⁻⁷	
	3			2.78x10 ⁻⁶	
	4			6.1x10 ⁻⁶	
	5	*4.2x10 ⁻⁶		1.9x10 ⁻⁴	*1x10 ⁻⁶
	6	1x10 ⁻⁵		9.9x10 ⁻⁴	5.3x10 ⁻⁵
	7	1.6x10 ⁻⁵	*2.1x10 ⁻⁶	**	1.6x10 ⁻⁴

* Less than value shown (0 errors occurred)

Table XIII Lenkurt 261A Test Results

Channel Sampling Rate	Number of Loopbacks	Average Error Rate	
		CVSD	Log CVSD
16 kbps	0	1.4×10^{-2}	1.4×10^{-2}
	1-7	**	**
32 kbps	0	$*2.6 \times 10^{-7}$	$*2.6 \times 10^{-7}$
	1	2.2×10^{-4}	1.4×10^{-4}
	2	1.8×10^{-3}	1.4×10^{-3}
	3	7×10^{-3}	7.9×10^{-3}
	4-7	**	**
	64 kbps	0-2	$*2.6 \times 10^{-7}$
	3	1.3×10^{-5}	6.4×10^{-6}
	4	7.7×10^{-5}	2.5×10^{-4}
	5	3.7×10^{-4}	1.0×10^{-4}
	6	3.4×10^{-4}	1.1×10^{-4}
	7	4.7×10^{-3}	1.4×10^{-3}

* Less than value shown (0 errors occurred)

** Test set out of lock

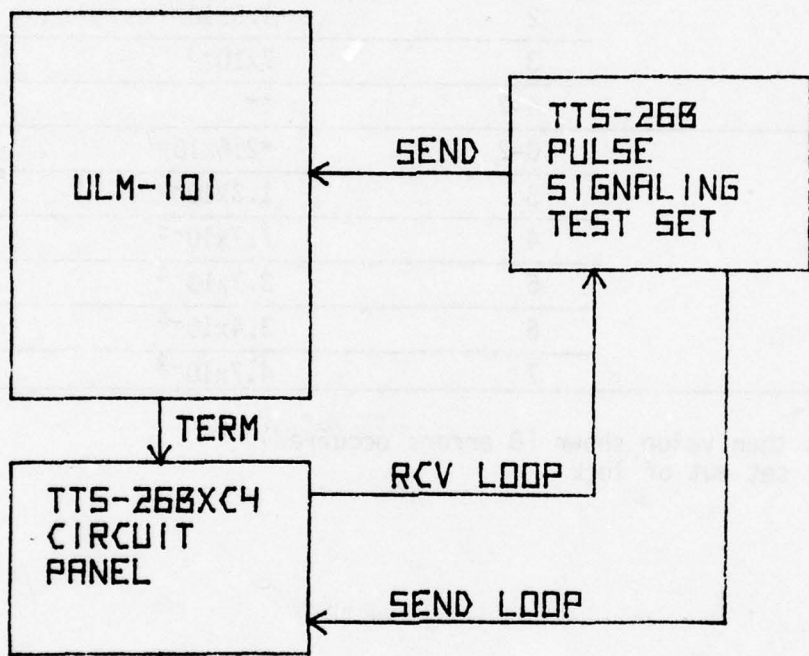

FIGURE 37. SF SIGNALING TEST CONFIGURATION

TTS-26BXS-1 Signaling Circuit Panel were used to originate a SF signal at pulse rates of 6, 8, 10, 12, 14, and 20 pps and at levels of -13, -16, -20, and -24 dBm. The carrier frequency was also varied between 1, 1.6, 2.4, and 2.6 kHz. The percent break of the transmitted signal was set to 67 percent. The percent break of the received signal from the ULM-101 was measured with the TTS-26B and recorded.

3.3.6.2.2 The test was performed for both coding techniques and all four sampling rates of the ULM-101.

3.3.6.3 Results and Analysis

3.3.6.3.1 Table XIV shows the results of the SF signaling test for a Log CVSD coding technique. Similar results were obtained for CVSD coding technique. The table shows that a ULM-101 sampling rate of 8 kbps resulted in an unacceptable signal for any input level, oscillator frequency, or pulsing rate. The 16 kbps sampling rate provided a useable signal at a few combinations of input level, oscillator frequency and pulsing rate but was generally also unuseable. The 32 kbps sampling rate, while providing more consistent results than either of the lower sampling rates, generally provided unacceptable signaling results. Only at a 64 kbps sampling rate did the ULM-101 provide signaling which might be useful in a commercial installation, and even this rate provided a few marginal results.

3.3.6.3.2 An overall review of the SF signaling test of the ULM-101 leads to the conclusion that the ULM-101 is unsatisfactory as a medium for transmitting SF signaling information. Data from a signaling test involving repeated loopbacks of the ULM-101 reveals that after two loopbacks, even the 64 kbps sampling rate yields unacceptable signaling information.

3.3.7 MF Signaling Test

3.3.7.1 Objective. The purpose of this test is to determine the ability of the ULM-101 to pass MF signaling information accurately.

3.3.7.2 Procedure

3.3.7.2.1 The equipment configuration for this test is shown on figure 38. The TTS-59B was used to originate a seven digit number which was transmitted via the ULM-101 to the TTS-2761 where the received frequency combination was detected, decoded and the number displayed. The TTS-59B transmitted the MF combinations at a level of -22 dBm.

3.3.7.2.2 The test was initially performed with the configuration of figure 38 and then was repeated for increasing number of loopbacks of the ULM-101 as described in paragraph 3.1.8 for the loop test.

3.3.7.2.3 The test was performed for both coding techniques and all four sampling rates of the ULM-101. The digits of the TTS-59B selector

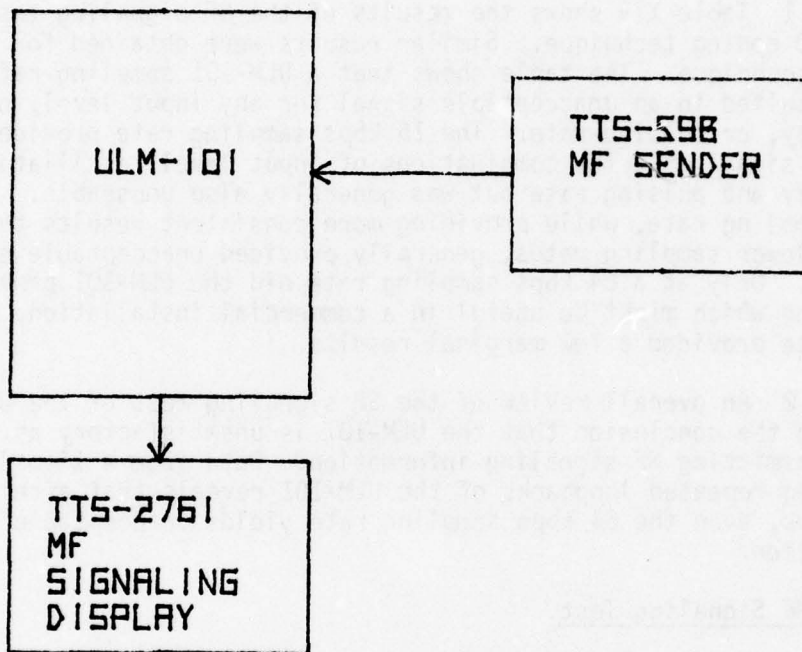

FIGURE 38. MF SIGNALING TEST CONFIGURATION

Table XIV. Part 1 - SF Signaling Test Summary

INPUT LEVEL (dBm)	ULM-101 SAMPLE RATE (kbps)	1 kHz Oscillator						1.6 kHz Oscillator					
		6	8	10	12	14	20	6	8	10	12	14	20
-13	8	95	100	100	100	100	100	94	100	100	100	100	100
	16	100	100	95	100	100	98	100	100	100	100	100	100
	32	74	76	77	81	82	90	75	80	82	87	88	96
	64	67	67	67	67	68	69	68	69	71	71	70	74
-16	8	92	100	100	100	100	100	90	100	100	100	100	100
	16	100	98	100	100	100	100	100	100	95	100	100	100
	32	70	80	79	81	82	90	75	78	80	88	88	92
	64	68	67	70	72	79	70	68	69	69	75	70	74
-20	8	97	100	100	100	100	100	95	100	100	100	100	100
	16	80	66	68	80	75	71	70	75	75	77	72	74
	32	77	78	80	85	85	95	75	78	82	85	88	97
	64	67	67	67	68	68	71	67	70	71	72	74	77
-24	8	100	100	100	100	100	100	100	100	100	100	100	100
	16	100	100	100	100	100	100	100	97	88	100	95	100
	32	72	72	75	76	80	85	76	75	78	80	85	90
	64	68	65	67	70	68	71	69	68	67	69	69	74

Table XIV. Part 2 - SF Signaling Test Summary

INPUT LEVEL (dBm)	ULM-101 SAMPLE RATE (kbps)	2.4 kHz Oscillator					2.6 kHz Oscillator						
		6	8	10	12	14	20	6	8	10	12	14	20
-13	8	10	5	25	20	20	25	15	25	15	22	30	35
	16	67	67	67	67	67	69	100	100	100	100	100	100
	32	75	77	80	82	86	94	86	78	84	85	90	97
	64	69	70	72	73	75	78	70	70	74	72	75	79
-16	8	5	0	25	10	10	20	5	15	20	20	15	10
	16	66	67	67	72	67	69	100	100	100	74	100	100
	32	75	78	80	96	85	95	75	77	81	88	87	96
	64	69	70	71	77	74	76	69	71	71	76	74	77
-20	8	5	10	20	25	15	20	5	10	15	20	20	20
	16	68	67	68	67	69	73	100	100	100	100	100	100
	32	70	71	72	73	77	81	77	81	84	88	94	100
	64	70	72	73	74	76	80	70	72	74	75	76	83
-24	8	100	10	0	20	10	15	5	15	15	35	20	20
	16	75	98	100	100	100	100	97	95	100	95	100	100
	32	68	75	79	85	87	96	76	76	80	84	85	96
	64	5	68	68	71	70	75	69	68	68	74	70	75

for each test run were varied so that all ten digits were used. Two measurements were made at each sampling rate.

3.3.7.3 Results and Analysis

3.3.7.3.1 Table XV shows the results of the test of MF signaling combinations with the ULM-101. For a single transit through the ULM-101, only the 8 kbps sampling rate provided an erroneous digit; at other sampling rates the dialing information was correctly transmitted. As the MF signal was looped-back through the ULM-101, errors were introduced in the dialing information at all sampling rates.

3.3.7.3.2 When errors occurred in the transmission of digits, the indication on the signaling display was that more than two tones had been received (the signaling is based on pairs of tones from the basic six tones available). When a wrong number was decoded, the cause was probably the detection circuits of the signaling using an erroneous tone in its decision of what number was transmitted. The erroneous tones are created by intermodulation of the two basic tones and by internally generated spurious signals. Repeated loopbacks through the ULM-101 strengthen those unwanted tones.

3.3.7.3.3 The use of the ULM-101 for the transmission of MF signaling combinations is questionable. Normal noise encountered in a switching network would probably be sufficient to create errors in the transmission of signaling information when passed through the ULM-101.

3.4 DATA MODEM-ERROR INJECTION TEST

3.4.1 General

3.4.1.1 Objective. The purpose of the Data Modem - Error Injection test is to continue the evaluation of paragraph 3.3 with a simulated error environment at the output of the ULM-101.

3.4.1.2 Procedure

3.4.1.2.1 The test configuration was identical to that of paragraph 3.3 with two exceptions. Only one ULM-101 multiplexer was used and a General Data Products DLS-106 Data Link Simulator and model BAMI/TTL interface converter were connected between the CABLE Transmit and CABLE Receive ports of the ULM-101. Other interfaces are unchanged. The DLS-106 Data Link Simulator was used to inject errors in the ULM-101 output. Error rates of 10^{-2} to 10^{-7} were used.

3.4.1.2.2 The DLS-106 Data Link Simulator creates errors in a digital pattern by inverting bits in a pseudo-random manner throughout the pattern. Error rates between 0.5 and 1×10^{-9} can be created while operating at data rates up to 13 Mbps. The error rate created by the DLS-106 is selected using five front-panel thumbwheel switches. The

Table XV. MF Signalling Test Summary

Number of Loopbacks	Code Technique	Channel Rate (kbps)	Number of Errors	
			1st Attempt	2d Attempt
0	CVSD	8	1	0
		16	0	0
		32	0	0
		64	0	0
	Log CVSD	8	3	1
		16	0	0
		32	0	0
		64	0	0
1	CVSD	8	6	5
		16	4	1
		32	0	0
		64	1	1
	Log CVSD	8	4	5
		16	1	1
		32	2	0
		64	0	0
2	CVSD	8	4	6
		16	2	1
		32	2	2
		64	1	0
	Log CVSD	8	5	3
		16	1	1
		32	3	2
		64	3	1
3	CVSD	8	6	5
		16	4	3
		32	3	1
		64	4	1
	Log CVSD	8	6	4
		16	3	3
		32	3	3
		64	1	4

error rate can be represented by the equation $ER=(m \times 10^{-n})(OPQ)$ where m and n are separate switches selectable from 0 through 9 and OPQ are three switches to set a three digit number between 000 and 999. The number set for OPQ represents the number of errors in a single burst. For the evaluation of the General Dynamics ULM-101, OPQ was set to 001. The DLS-106 was used in the T1 line (CABLE Rx and Tx Connectors) of the ULM-101. Since the DLS-106 is a TTL NRZ device, an interface box had to be used to convert from bipolar AMI to NRZ on the input side, and from NRZ to bipolar AMI on the output side. The General Data Products Model BAMI/TTL Interface Converter was used for this purpose. This box converts from a 100 ohm balanced bipolar alternate mark inverted signal at +3 volts to NRZ data and clock signals at TTL levels and back again. The unit operates at a T1 rate of 1.544 Mbps.

3.4.2 VFCT (AN/FCC-19) - Error Injection Test

3.4.2.1 Procedure. The procedure for this test is as given in 3.3.2.1 and 3.4.1.

3.4.2.2 Results and Analysis

3.4.2.2.1 Results are given in Table XVI. At ULM-101 rates of 8 and 16 kbps the data passed was unacceptable as would be expected considering the results of paragraph 3.3.4. At ULM-101 rates of 32 and 64 kbps, performance of the ULM-101-AN/FCC-19 combination is essentially unchanged with injected error rates of 10^{-2} to 10^{-7} . Although Table XVI shows lower error rates than Table IX, this reflects long sampling times only.

Table XVI. VFCT Test Results (Error Injection)

AN/FCC-19 Channel Frequency	ULM-101 Sampling Rate (kbps)	Range of Average Output Error Rate Injected Error Rate of 10^{-2} to 10^{-7}	
		CVSD Coding	Log CVSD Coding
425 Hz	8	1.1×10^{-1} to 9×10^{-2}	1.37×10^{-1} to 1.03×10^{-1}
	16	1.6×10^{-2} to 1.1×10^{-2}	1.68×10^{-2} to 1.08×10^{-2}
	32	2.41×10^{-2} to 4.89×10^{-4}	2.78×10^{-2} to 4.4×10^{-4}
	64	9.11×10^{-3} to 1.38×10^{-4}	8.18×10^{-5} to 1.38×10^{-4}
1615 Hz	8	1.06×10^{-1} to 8.1×10^{-2}	9.3×10^{-2} to 9.1×10^{-2}
	16	1.02×10^{-2} to 7.36×10^{-3}	1.03×10^{-2} to 7.07×10^{-3}
	32	6.22×10^{-4} to 3.46×10^{-4}	7.11×10^{-4} to 2.76×10^{-4}
	64	1.24×10^{-4} to 8.88×10^{-5}	1.24×10^{-4} to 3.11×10^{-5}
2975 Hz	8	1.17×10^{-1} to 9.1×10^{-2}	1.16×10^{-1} to 9.6×10^{-2}
	16	6.46×10^{-3} to 5.44×10^{-3}	6.04×10^{-3} to 5.11×10^{-3}
	32	4.44×10^{-5} to 2.44×10^{-5}	6.22×10^{-5} to 1.55×10^{-5}
	64	less than 6.94×10^{-7}	less than 2.22×10^{-6}

3.4.3 Telephone Modem (MD-775) - Error Injection Test

3.4.3.1 Procedure. The procedure given in 3.4.1 was followed.

3.4.3.2 Result and Analysis

3.4.3.2.1 Results of this test are given in Table XVII. ULM-101 channel sampling rates of 8 and 16 kbps are not shown, as no useable data could be passed at these rates.

3.4.3.2.2 The MD-775 operated virtually error free (BER no worse than 10^{-6}) at all baud rates with an injected ULM-101 output error rate between 10^{-7} and 10^{-4} and an ULM-101 sampling rate of 32 kbps. At an injected error rate of 10^{-3} the data output of the modem becomes marginal (10^{-4} to 10^{-5} BER) at all baud rates. The MD-775 data was unuseable with an injected error rate of 10^{-2} .

3.4.3.2.3 At a ULM-101 sampling rate of 64 kbps, the MD-775 operated error-free at all baud rates with an injected group error rate between 10^{-3} and 10^{-7} . At a ULM-101 injected error rate of 10^{-2} the data from the MD-775 at all baud rates was marginal.

3.4.4 Low Speed Data Modem (MD-674) Error Injection Test

3.4.4.1 Procedure. The procedure given in 3.4.1 was followed.

3.4.4.2 Results and Analysis

3.4.4.2.1 Results of this test are given in Table XVIII. Useable data could not be obtained for a ULM-101 sampling rate of 8 kbps except with the MX-7374/G modem subassembly operating at 150 baud. Error free data was obtained with injected group error rates of 10^{-2} to 10^{-7} .

3.4.4.2.2 At a 16 kbps channel sampling rate, injected group error rates of 10^{-6} or 10^{-7} resulted in no degradation in the MD-674 for all three modem subassemblies. At injected group error rates of 10^{-4} or 10^{-5} the data was marginal except when using the MX-7374/G subassembly which operated error free. At injected error rates of 10^{-2} and 10^{-3} data from the MD-674 was unuseable for the MX-7375/G and MX-7379/G modem subassemblies. The MX-7374/G was still error free.

3.4.4.2.3 At a 32 kbps channel sampling rate, essentially error-free data was obtained from the MD-674 with injected error rates of 10^{-3} to 10^{-7} . An injected error rate of 10^{-2} resulted in marginal to unuseable data from the MX-7375/G and MX-7379/G modem subassemblies. The MX-7374/G was still error free.

Table XVII. MD-775/GCC Test Results (Error Injection)

Modem Baud Rate Coding	ULM-101 Channel Sampling Rate (kbps)	Burst Error Rate	CVSD Coding	Log CVSD
2400	32	10 ⁻³	4.85x10 ⁻⁵	5x10 ⁻⁵
		10 ⁻⁴ 10 ⁻⁵ to 10 ⁻⁷	1.94x10 ⁻⁶ 3.91x10 ⁻⁷	2.91x10 ⁻⁶ 9.03x10 ⁻⁷
1200	32	10 ⁻²	2.08x10 ⁻⁵	2.25x10 ⁻⁵
		10 ⁻³ to 10 ⁻⁷	7.23x10 ⁻⁹	6.94x10 ⁻⁸
600	32	10 ⁻³	4.94x10 ⁻⁵	4.81x10 ⁻⁵
		10 ⁻⁴ to 10 ⁻⁷	8.33x10 ⁻⁷	1.39x10 ⁻⁷
300	32	10 ⁻²	1.08x10 ⁻⁵	1.28x10 ⁻⁵
		10 ⁻³ to 10 ⁻⁷	1.45x10 ⁻⁸	1.39x10 ⁻⁷
150	32	10 ⁻³	3.17x10 ⁻⁵	1.97x10 ⁻⁴
		10 ⁻⁴ to 10 ⁻⁷	5.56x10 ⁻⁷	4.34x10 ⁻⁷
150	64	10 ⁻²	3.36x10 ⁻⁴	3.79x10 ⁻⁴
		10 ⁻³ to 10 ⁻⁷	3.78x10 ⁻⁷	2.78x10 ⁻⁷
150	64	10 ⁻³	4.56x10 ⁻⁵	6x10 ⁻⁵
		10 ⁻⁴ to 10 ⁻⁷	5.56x10 ⁻⁷	1.11x10 ⁻⁶
150	64	10 ⁻²	2.61x10 ⁻⁴	2.66x10 ⁻⁴
		10 ⁻³ to 10 ⁻⁷	5.56x10 ⁻⁷	5.56x10 ⁻⁷
150	64	10 ⁻³	1.06x10 ⁻⁴	1x10 ⁻⁴
		10 ⁻⁴ to 10 ⁻⁷	5.78x10 ⁻⁷	1.11x10 ⁻⁶
150	64	10 ⁻²	9.95x10 ⁻⁴	9.2x10 ⁻⁴
		10 ⁻³ to 10 ⁻⁷	1.11x10 ⁻⁶	1.11x10 ⁻⁶

Table XVIII. Part 1 - MD-674(P)/G Test Results (Error Injection)

Modem Subassembly	Modem Baud Rate	ULM-101 Channel Sampling Rate (kbps)	Burst Error Rate	Average Output Error Rate		
				CVSD Coding	Log CVSD Coding	
MX-7379	1200	16	10 ⁻³	1.59x10 ⁻³	1.72x10 ⁻³	
			10 ⁻⁴	1.59x10 ⁻⁴	1.48x10 ⁻⁴	
			10 ⁻⁵	1.75x10 ⁻⁵	1.52x10 ⁻⁵	
			10 ⁻⁶	1.53x10 ⁻⁶	8.33x10 ⁻⁷	
			10 ⁻⁷	*1.39x10 ⁻⁷	*1.39x10 ⁻⁷	
		32	10 ⁻²	9.7x10 ⁻⁴	7.8x10 ⁻⁵	
		10 ⁻³	9.7x10 ⁻⁶	1x10 ⁻⁵		
		10 ⁻⁴ to 10 ⁻⁷	*2.78x10 ⁻⁷	*5.56x10 ⁻⁷		
		64	10 ⁻²	1.08x10 ⁻⁵	1.14x10 ⁻⁵	
			10 ⁻³ to 10 ⁻⁷	*1.4x10 ⁻⁷	*1.45x10 ⁻⁸	
	600	16	16	10 ⁻²	1.37x10 ⁻²	1.43x10 ⁻²
				10 ⁻³	1.61x10 ⁻³	1.71x10 ⁻³
				10 ⁻⁴	1.69x10 ⁻⁴	1.66x10 ⁻⁴
				10 ⁻⁵	1.72x10 ⁻⁵	1.66x10 ⁻⁵
				10 ⁻⁶	2.22x10 ⁻⁶	5.55x10 ⁻⁷
			10 ⁻⁷	2.78x10 ⁻⁷	2.78x10 ⁻⁷	
			32	10 ⁻²	1.2x10 ⁻³	1.13x10 ⁻³
				10 ⁻³	1.33x10 ⁻⁵	1x10 ⁻⁵
			10 ⁻⁴ to 10 ⁻⁷	*5.56x10 ⁻⁷	*5.56x10 ⁻⁷	
		64	10 ⁻²	1.33x10 ⁻⁵	1.11x10 ⁻⁵	
				*5.56x10 ⁻⁷	*5.56x10 ⁻⁷	
150		16	16	10 ⁻²	1.58x10 ⁻²	1.42x10 ⁻²
	10 ⁻³			1.46x10 ⁻³	1.42x10 ⁻³	
	10 ⁻⁴			1.4x10 ⁻⁴	1.53x10 ⁻⁴	
	10 ⁻⁵			1.77x10 ⁻⁵	1.77x10 ⁻⁵	
	10 ⁻⁶ to 10 ⁻⁷			*1.11x10 ⁻⁶	1.11x10 ⁻⁶	
			32	10 ⁻²	1.02x10 ⁻³	8.04x10 ⁻⁴
			10 ⁻³	8.88x10 ⁻⁶	1.33x10 ⁻⁵	
			10 ⁻⁴ to 10 ⁻⁷	*1.11x10 ⁻⁶	*1.11x10 ⁻⁶	
		64	10 ⁻²	1.11x10 ⁻⁵	8.89x10 ⁻⁶	
			10 ⁻³ to 10 ⁻⁷	1.11x10 ⁻⁶	1.11x10 ⁻⁶	

* Less than value shown

AD-A062 018

ARMY COMMUNICATIONS-ELECTRONICS ENGINEERING INSTALLAT--ETC F/G 17/2
DIGITAL TRANSMISSION EVALUATION PROJECT UNIVERSAL LOOP MULTIPLE--ETC(U)
NOV 78 J E HAMANT, O P CONNELL, H S WALCZYK
CCC-CED-78-DTEP-017

UNCLASSIFIED

2 OF 2

AD
A062 018

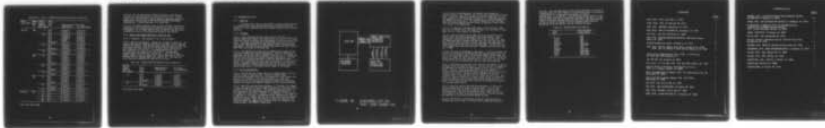

NL

END
DATE
FILMED
3--79
DDC

Table XVIII. Part 2 - MD-674(P)/G Test Results (Error Injection)

Modem Subassembly	Modem Baud Rate	ULM-101 Channel Sampling Rate (kbps)	Burst Error Rate	Average Output Error Rate	
				CVSD Coding	Log CVSD Coding
MX-7375	600	8	10 ⁻⁶	4.87x10 ⁻³	4.27x10 ⁻³
			10 ⁻⁷	4.78x10 ⁻³	4.82x10 ⁻³
		16	10 ⁻²	3.01x10 ⁻³	3.17x10 ⁻³
			10 ⁻³	1.93x10 ⁻⁴	2.05x10 ⁻⁴
			10 ⁻⁴	8.85x10 ⁻⁵	8.94x10 ⁻⁵
			10 ⁻⁵	5x10 ⁻⁶	6.67x10 ⁻⁶
			10 ⁻⁶ to10 ⁻⁷	1.67x10 ⁻⁶	1.11x10 ⁻⁶
		32	10 ⁻²	2.03x10 ⁻⁴	2.15x10 ⁻⁴
	10 ⁻³		1.67x10 ⁻⁶	1.67x10 ⁻⁶	
	10 ⁻⁴ to10 ⁻⁷		*2.78x10 ⁻⁷	*2.78x10 ⁻⁷	
	64	10 ⁻²	7.22x10 ⁻⁶	1.11x10 ⁻⁵	
		10 ⁻³ to10 ⁻⁷	*2.89x10 ⁻⁸	*2.78x10 ⁻⁷	
	300	16	10 ⁻²	1.6x10 ⁻²	1.96x10 ⁻²
			10 ⁻³	1.23x10 ⁻³	1.26x10 ⁻³
			10 ⁻⁴	1.43x10 ⁻⁴	1.34x10 ⁻⁴
			10 ⁻⁵	1.11x10 ⁻⁵	2.11x10 ⁻⁵
			10 ⁻⁶ to10 ⁻⁷	*3.33x10 ⁻⁶	*1.04x10 ⁻⁶
			32	10 ⁻²	1.39x10 ⁻³
		10 ⁻³		5.56x10 ⁻⁶	5.56x10 ⁻⁶
		10 ⁻⁴ to10 ⁻⁷		*5.56x10 ⁻⁷	*5.56x10 ⁻⁷
64		10 ⁻²	2.56x10 ⁻⁵	7.56x10 ⁻⁵	
		10 ⁻³ to10 ⁻⁷	*5.56x10 ⁻⁷	*5.56x10 ⁻⁷	
		150	16	10 ⁻²	1.28x10 ⁻²
10 ⁻³				6.93x10 ⁻⁴	7.51x10 ⁻⁴
10 ⁻⁴	5.56x10 ⁻⁵			8.88x10 ⁻⁵	
10 ⁻⁵ to10 ⁻⁷	*8.1x10 ⁻⁷			*1.11x10 ⁻⁶	
32	10 ⁻²		8.53x10 ⁻⁴	8.18x10 ⁻⁴	
	10 ⁻³ to10 ⁻⁷		*2.54x10 ⁻⁶	8.89x10 ⁻⁶	
64	10 ⁻² to10 ⁻⁷	*6.67x10 ⁻⁶	*3.33x10 ⁻⁶		
MX-7374	150	8	10 ⁻²	*4.44x10 ⁻⁶	*1.5x10 ⁻⁶
		16	10 ⁻²	*1.11x10 ⁻⁶	*1.16x10 ⁻⁷
		32	10 ⁻²	*1.11x10 ⁻⁶	*1.11x10 ⁻⁶
		64	10 ⁻²	*1.11x10 ⁻⁶	*1.11x10 ⁻⁶

* Less than value shown

3.4.4.2.4 At a 64 kbps channel sampling rate error free data was obtained for injected group error rates of 10^{-3} to 10^{-7} . A 10^{-2} inject error rate resulted in good to marginal data from the MD-674 depending on the baud rate of the MX-7375/G and MX-7379/G modem subassemblies. The MX-7374/G was still error free.

3.4.4.2.5 At ULM-101 sampling rates of 32 and 64 kbps, satisfactory transmission can be obtained with the MD-674 in a fairly harsh error environment. At a 16 kbps sampling rate, the MD-674 data was quite vulnerable to errors in the group data stream of the ULM-101.

3.4.5 Digital Data Modem (261A)-Error Injection Test

3.4.5.1 Procedure. The procedure in 3.4.1 was followed.

3.4.5.2 Results and Analysis. Results are as shown in Table XIX. No useable data could be obtained with the 8 or 16 kbps channel sampling rates of the ULM-101. With the 32 channel sampling rate, the 261A data was passed with error rates of 10^{-7} or better when injected group error rates were 10^{-4} to 10^{-7} . An injected group error rate of 10^{-3} resulted in an output error rate of 10^{-5} . The data was unuseable when the group error rate was 10^{-2} . With the 64 kbps channel sampling rate, an output error rate on the order of 10^{-6} was obtained with an injected group error rate of 10^{-2} . The data was error free with injected error rates of 10^{-3} to 10^{-7} .

Table XIX. Lenkurt 261A Test Results (Error Injection)

ULM-101 Channel Sampling Rate (kbps)	Burst Error Rate	Average Output CVSD Coding	Error Rate Log CVSD Coding
32	10^{-2}	1.1×10^{-3}	1.2×10^{-3}
	10^{-3}	1.8×10^{-5}	2×10^{-5}
	10^{-4}	6.9×10^{-7}	8.3×10^{-7}
	10^{-5} to 10^{-7}	$*2.6 \times 10^{-7}$	$*2.8 \times 10^{-7}$
64	10^{-2}	7.2×10^{-6}	4.6×10^{-6}
	10^{-3} to 10^{-7}	$*2.6 \times 10^{-7}$	$*2.6 \times 10^{-7}$

* Less than value shown

3.5 SYNCHRONIZATION TEST

3.5.1 Objective

To determine the time for the ULM-101 to acquire synchronization at different error rates and determine the error rate at which the ULM-101 will lose synchronization after proper synchronization has been acquired.

3.5.2 Procedure

3.5.2.1 Figure 39 shows the test setup used for this test. A Hewlett-Packard Model 5262A Time Interval Unit was used in the HP-5245L Electronic Counter to measure the time between a start pulse and a stop pulse. The start pulse used was obtained from the search test point (TP3) on the Demultiplexer and Frame Synchronization circuit card of the ULM-101. The stop pulse was derived from either the CHECK (TP8) or LOCK (TP7) test points on the same card.

3.5.2.2 The ULM-101 was forced into the SEARCH mode by means of the front panel FRAME LOCK indicator/pushbutton. When this pushbutton is depressed, the counters used to determine when the set is in CHECK and LOCK are reset and the unit re-initiates sync acquisition. The time for the unit to proceed from CHECK to LOCK was measured for each condition of injected errors from a zero error rate to an error rate of 1×10^{-2} . The General Data Products Model DLS-106 Data Link Simulator and Model BAMI/TTL Interface Converter were used to inject errors in a pseudo-random manner in the group digital output of the ULM-101.

3.5.3 Results and Analysis

3.5.3.1 The ULM-101 uses frames 193 bits in length frames, with the 193rd bit being a frame sync bit. The total ULM-101 frame synchronization pattern is an 8-bit PN sequence with the property that each bit is a function of the previous three bits. Once four consecutive bits are received, the system can compute the remaining sequence and compare the computed sequence with the received sequence.

3.5.3.2 When the synchronization procedure is initiated, five frames of data are required to load the sample registers for frame sync before a check of frame sync can begin. The computed frame sync pattern is then compared to the incoming pattern on a frame-by-frame basis. If the comparison is positive, a counter is incremented; if the comparison is negative, a slip pulse is generated and the incoming pulse train is slipped one bit to compare the next bit in the frame with the computed frame sync sequence. When five consecutive positive comparisons are obtained between the computed and received frame sync sequences, the system advances from SEARCH to CHECK mode.

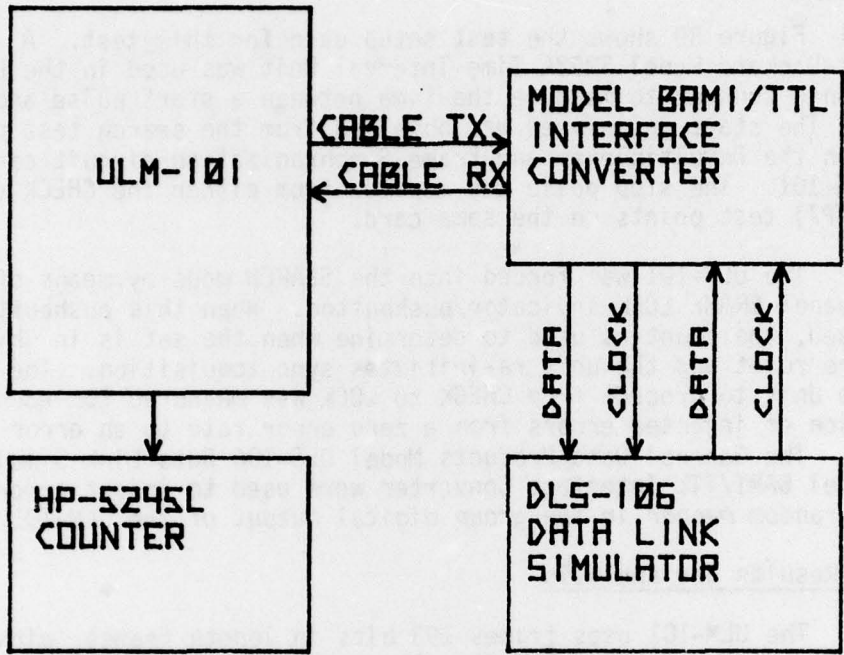

FIGURE 39. SYNCHRONIZATION TEST CONFIGURATION

3.5.3.3 Once in the CHECK mode, the ULM-101 uses a Sequential Probability Ratio Test (SPRT) as the criteria for advancing to the LOCK mode. A positive comparison between the received frame sync bit and the computed sync bit increments a counter by 1; a negative comparison decrements the counter by 2. The ULM-101 advances to the LOCK mode when the counter reads 28 positive counts; 28 negative counts results in a return to the SEARCH mode.

3.5.3.4 It requires a minimum of 28 frames x 193 bits/frame = 5404 bits for the ULM-101 to go from CHECK to LOCK. At a bit rate of 1.544 Mbps, this is a time interval of 3500 msec.

3.5.3.5 Three test points are brought out of the circuitry on the Demultiplexer and Frame Synchronizer card of the ULM-101. These signals are, respectively, NOT SEARCH, NOT CHECK, and NOT LOCK. The NOT SEARCH test point changes state when the unit goes into the CHECK mode; the NOT CHECK test point changes state when the CHECK mode is entered and when the unit goes into the LOCK mode. The NOT LOCK test point changes state when the LOCK mode is entered and if the unit goes out of LOCK.

3.5.3.6 The test was conducted in two phases. In the first phase, the ULM-101 was forced into the SEARCH mode and time was measured for the unit to go from CHECK to LOCK, using the NOT SEARCH and NOT CHECK test points to trigger the start and stop inputs of the counter. During the second phase, the unit was synchronized at a zero error rate and then the error rate was increased until the unit lost synchronization.

3.5.3.7 The results of the test of the time for the ULM-101 to acquire synchronization are shown on Table XX. The unit was able to advance to the LOCK mode in minimum time consistently at error rates as high as 1×10^{-4} . At error rates worse than 1×10^{-4} , the unit required a longer period to acquire synchronization, but was able to do so even at an error rate of 0.5. The error rates of 500×10^{-6} and 250×10^{-5} represent burst of 500 and 250 errors to create the error rate. This results in the unit requiring a slightly longer period to synchronize since the probability of an error occurring in a frame sync bit is higher in this case than when the errors are distributed individually in a pseudo-random fashion.

3.5.3.8 Once the unit had acquired synchronization, it maintained synchronization at error rates as high as 1×10^{-1} . The unit was tested for 15 minutes at an error rate of 1×10^{-1} without losing synchronization. The unit was designed to have a mean time to lose lock falsely of 23 years at an error rate of 0.2. An error rate of 1 was necessary to lose lock with the ULM-101 at DTEP.

3.5.3.9 The ability of the ULM-101 to maintain synchronization at extremely poor error rates is of great value in many applications of

the unit. Poor received signal quality can be tolerated in the case of transmitted voice or VFCT signals, so a multiplexer which will maintain synchronization in a high error environment is valuable. Alternatively, if the ULM-101 is used to process modem signals or other types of data which must be transmitted accurately, the ability of the ULM-101 to maintain synchronization at high error rates means that the ability of the entire system to maintain synchronization will be determined by the end devices, not the transmission media.

Table XX. Synchronization Test Results

Error Rate	Time From CHECK To LOCK (Msec)
0	3501
1x10 ⁻⁶	3501
1x10 ⁻⁵	3501
1x10 ⁻⁴	3501
500x10 ⁻⁶	4626-6126
1x10 ⁻³	3501-6376
5x10 ⁻³	6376
250x10 ⁻⁵	6376-7252
1x10 ⁻²	6502-6876
1x10 ⁻¹	6501-10877
5x10 ⁻¹	3501-16252

DISTRIBUTION

	<u>COPIES</u>
AFCS, ATTN: EETC, Scott AFB, IL 62225	1
AFTEC, ATTN: TEEC, Kirtland AFB, NM 87115	1
CSAF, ATTN: RDPE/PRCX, Washington, DC 20310	2
HQDA, ATTN: DAAC-SIT-SPE/DAMA-CSC, Washington, DC 20310	2
DCA, ATTN: Code 470, Washington, DC 20305	1
DCEC, ATTN: R105/R220/R320/R710/R110/R123, 1860 Wiehle Avenue, Reston, VA 22070	6
Defense Documentation Center, Alexandria, VA 22314	15
ECAC, ATTN: CAS (Mr. Mager), North Severn, Annapolis, MD 21402	2
ATTN: CAA (LTC Mitchell), North Severn, Annapolis, MD 21402	1
Joint Tactical Communications Office, ATTN: TT-E/TT-RI-TA, 197 Hance Road, New Shrewsbury, NJ	2
JTO, TRI-TAC, Fort Huachuca, AZ 85613	1
Mitre Corp., P.O. Box 208, ATTN: Mail Stop A160, Bedford, MA 01730	2
National Bureau of Standards, Electromagnetic Division, ATTN: W. J. Alspach, Boulder, CO 80302	1
Naval Telecommunications Command, ATTN: 621, Massachusetts Ave, NW, Washington, DC 20390	1
Naval Electronics Systems Command, ATTN: ELEX 51032, Washington, DC 20360	1
NCA, ATTN: EPE, Griffis AFB, NY 13440	2
NSA, ATTN: Code R15/S254/4023, Fort Meade, MD 20755	3
RADC, ATTN: DCLD/DCC, Griffis AFB, NY 13440	3
USACC, ATTN: CC-OPS-PT/CC-OPS-ST, Ft Huachuca, AZ 85613	4

DISTRIBUTION (Cont)

	<u>COPIES</u>
USACEEIA, ATTN: CCC-CED/CCC-TCO/CCC-TED/CCC-PRSO/CCC-CED-SET/ CCC-EMEO-PED, Ft Huachuca, AZ 85613	18
USACSA, ATTN: CCM-CCS/CCM-RD/CCM-CG/CCM-TD, Ft Monmouth, NJ 07703	4
US Department of Commerce, Office of Telecommunications, Institute for Telecommunications Sciences, ATTN: Richard Skerjanec, Boulder, CO 80302	1
USAEPG, STEEP-MT-GT, Ft Huachuca, AZ 85613	4
HQ ESD, ATTN: DCF, Hanscom AFB, MA 01731	2
National Technical Information Service, 5185 Port Royal Road, Springfield, VA 22161	1
USATECOM, ATTN: DRSTE-EL, Aberdeen Proving Ground, MD 21005	2
USACORADCOM, ATTN: DRDCO-COM-RM/DRDCO-COM-RF, Ft Monmouth, NJ 07703	5
DCA-PAC, ATTN: P308, Wheeler AFB, HI 96854	1
DCA-EUR, ATTN: E420, APO New York 09131	1
USACEEIA-PAC, ATTN: CCCP-PO, Ft Shafter, HI 96858	1
USACEEIA-EUR, APO New York 09056	1
USACEEIA-CONUS, Ft Ritchie, MD 21719	1