

AD-A062 024

MASSACHUSETTS INST OF TECH CAMBRIDGE DEPT OF MATERIA--ETC F/G 11/6
HYDROGEN INDUCED INTERGRANULAR CRACKING OF NICKEL-BASE ALLOYS.(U)
OCT 78 R M LATANISION, F T LEE, M KURKELA N00014-78-C-0002

UNCLASSIFIED

TR-2

NL

1 OF 1
AD
A062 024



END
DATE
FILMED
3--79
DDC

LEVEL II

12

AD A062024

DDC FILE COPY

6 HYDROGEN INDUCED INTERGRANULAR CRACKING OF NICKEL-BASE ALLOYS.

10 by R.M. /Latanision, F.T.S. /Lee and M. /Kurkela

9 Technical Report, No. 2 ✓ 14 TR-2

15 Office of Naval Research Contract No. N00014-78-C-0002 NR 036-127/8-24-77(471)

Reproduction in whole or in part is permitted for any purpose of the United States Government.

DDC RECEIVED DEC 11 1978

12 28p. Corrosion Laboratory

Department of Materials Science and Engineering Massachusetts Institute of Technology

Cambridge, Massachusetts 02139

ACCESSION for DTIC White Section [X] DTIC Gift Section [] UNANNOUNCED [] JUSTIFICATION Per Its. on file BY DISTRIBUTION/AVAILABILITY CODES Sig. AVAIL. and/or SPECIAL A

11 October 1978

DISTRIBUTION STATEMENT A Approved for public release; Distribution Unlimited

78 11 16 025 409 463 LB

REPORT DOCUMENTATION PAGE		READ INSTRUCTIONS BEFORE COMPLETING FORM
1. REPORT NUMBER	2. GOVT ACCESSION NO.	3. RECIPIENT'S CATALOG NUMBER
4. TITLE (and Subtitle) Hydrogen Induced Intergranular Cracking of Nickel-Base Alloys		5. TYPE OF REPORT & PERIOD COVERED Technical Report
		6. PERFORMING ORG. REPORT NUMBER
7. AUTHOR(s) R.M. Latanision, F.T.S. Lee, M. Kurkela		8. CONTRACT OR GRANT NUMBER(s) N00014-78-C-0002 NR 036-127/8-24/77(471)
9. PERFORMING ORGANIZATION NAME AND ADDRESS Massachusetts Institute of Technology Cambridge, Massachusetts 02139		10. PROGRAM ELEMENT, PROJECT, TASK AREA & WORK UNIT NUMBERS
11. CONTROLLING OFFICE NAME AND ADDRESS Office of Naval Research 800 Quincy Street Arlington, VA 22217		12. REPORT DATE October 1978
		13. NUMBER OF PAGES 12
14. MONITORING AGENCY NAME & ADDRESS (if different from Controlling Office)		15. SECURITY CLASS. (of this report)
		15a. DECLASSIFICATION/DOWNGRADING SCHEDULE
16. DISTRIBUTION STATEMENT (of the report) <div style="border: 1px solid black; padding: 5px; text-align: center;">DISTRIBUTION STATEMENT A Approved for public release; Distribution Unlimited</div>		
17. DISTRIBUTION STATEMENT (of the abstract entered in Block 20, if different from Report)		
18. SUPPLEMENTARY NOTES hydrogen permeation, hydrogen embrittlement, nickel alloys, impurities		
19. KEY WORDS (Continue on reverse side if necessary and identify by block number)		
20. ABSTRACT (Continue on reverse side if necessary and identify by block number) This report is intended to summarize the activities pursued during the first year of a program directed toward an evaluation of the susceptibility of nickel and nickel base alloys to embrittlement by cathodically produced hydrogen. Preliminary results suggest that hydrogen permeation in unstrained membranes occurs by lattice diffusion rather than by alternate short circuiting mechanisms. Work is in progress to evaluate the contribution of dislocation transport to the permeation flux.		

1. Introduction

Earlier work [1] has shown that commercially pure nickel tensile specimens are susceptible to intergranular cracking when exposed to cathodically produced hydrogen in aqueous electrolytes at ambient conditions. Cracking was associated with the accumulation of impurities such as Sn, Sb, P and S and the depletion of Cu in the grain boundaries. The segregated elements are known to be poisons for the combination of hydrogen adatoms produced by proton reduction and, hence, stimulate the absorption of hydrogen by the metal. Significantly, this susceptibility may be eliminated if the above grain boundary partitioning is avoided during heat treatment [2]. The intergranular cracking of nickel-base alloys used, for example, as tubing material in pressurized water reactor (PWR) steam generators [3] as well as in oil and gas production [4][5] and chemical processing applications is in many respects phenomenologically similar to that of pure nickel [6]. Hence, the principal aim of this program is to examine the cracking of alloys such as Inconel 600, Incoloy 800, and Hastelloy C-276 polarized cathodically in aqueous electrolytes at ambient conditions in the context that cracking may be induced by hydrogen.

This report is intended to serve as a summary of our activities during the first year of this program. Research in progress is proceeding in essentially two directions: firstly, straining electrode experiments are underway on nickel-base alloys polarized

cathodically in acid and alkaline electrolytes under ambient conditions. At the same time, parallel hydrogen permeation experiments are being performed on membranes of the same alloys having identical metallurgical histories. This report will emphasize the permeation measurements which are furthest along.

Experimental

The basis for the permeation experiments which are being pursued may be understood with the aid of Figure 1. Hydrogen permeation may be presumed to occur by means of lattice diffusion, grain boundary diffusion or, in the case of specimens undergoing plastic deformation, dislocation transport [8][9]. We expect that some hydrogen may be preferentially absorbed into the matrix at grain boundary intersections with the free surface and then travel along such boundaries throughout the bulk. Of course, hydrogen enters the solid at locations other than poisoned grain boundaries, evidence for which is the fact that serrated yielding occurs during tensile deformation of nickel single crystals charged with hydrogen while being deformed [10]. Dislocation-hydrogen interactions have been observed in precharged nickel single crystals as well [11]. Hence, some hydrogen is likely to be dragged into the interior along with mobile dislocations and may accumulate at grain boundaries as suggested in Figure 1. Lattice diffusion in nickel single crystals is relatively slow:

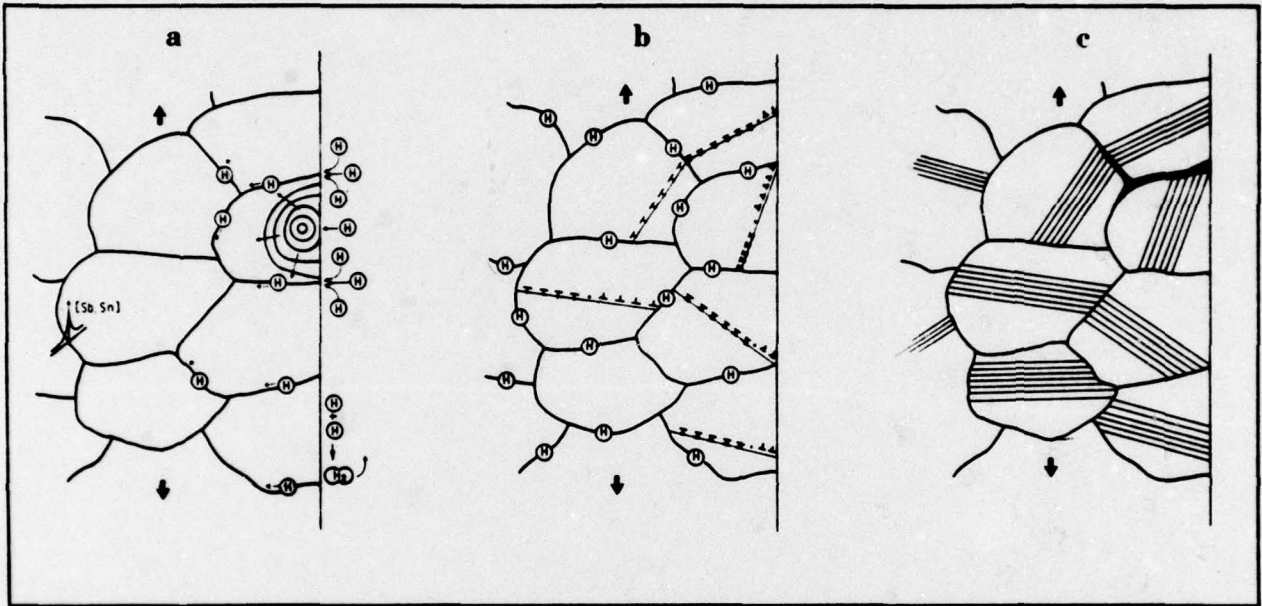

FIGURE 1. Processes likely to be involved in embrittlement [7].

78 11 16 025

the diffusion coefficient for hydrogen at 25°C is of the order of 10^{-10} cm²/sec [12][13]. The present work is intended to determine the contribution of each such transport process in the permeation of hydrogen through nickel and nickel-base alloys.

The experimental cell which is being used in this work is shown in Figure 2. This cell is of the Devanathan design [14] with the exception that provision has been made to allow the membranes under study to be plastically deformed while being cathodically charged with hydrogen. In this technique, cathodically generated atomic hydrogen is absorbed into a metal specimen (typically 100 - 150 μm thick), travels the thickness and is subsequently oxidized on the anodically polarized exit side, as shown schematically in Figure 3. The hydrogen oxidation current is a direct measure of the rate at which hydrogen permeates the membrane. A typical transient for a palladium membrane is shown in Figure 4. Palladium is perhaps the most hydrogen permeable metal, and serves in this case to demonstrate the operational performance of our permeation cell. Detailed analysis of such transients presents some uncertainties as described by Namboodhiri and Nanis [15] or more recently by Early [16]. Nevertheless, one may calculate with reasonable confidence both the hydrogen diffusion coefficient and the concentration of hydrogen just beneath the cathode surface. In the case of Figure 4, the diffusivity of hydrogen in Pd was determined to be $1.0 \pm 0.3 \times 10^{-7}$ cm²/sec which compares very well indeed with values reported in the literature for both electrochemical and non-electrochemical measurements.

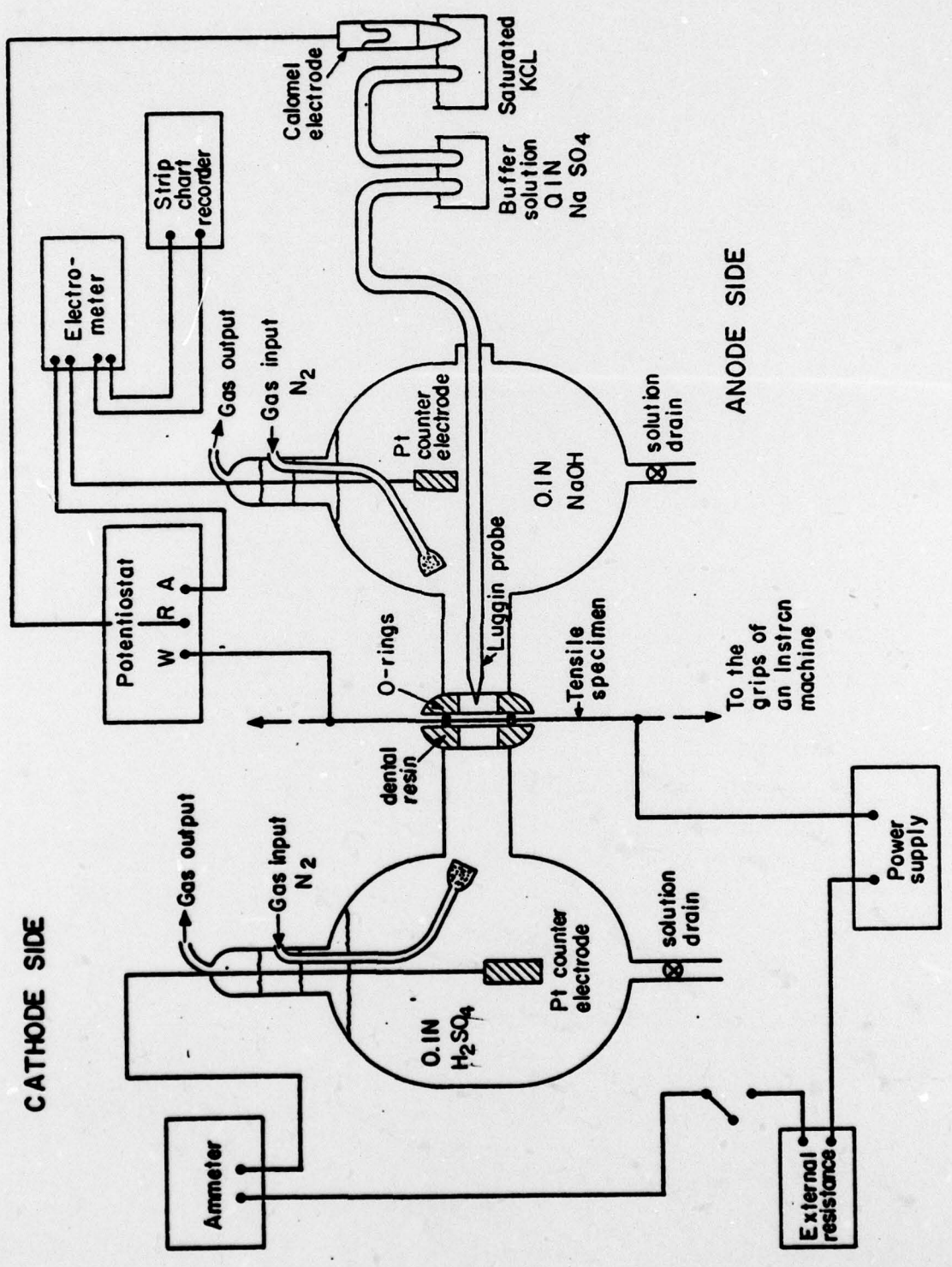

FIGURE 2. Schematic of Devanathan type permeation cell, modified to allow plastic deformation of the specimen while being cathodically charged.

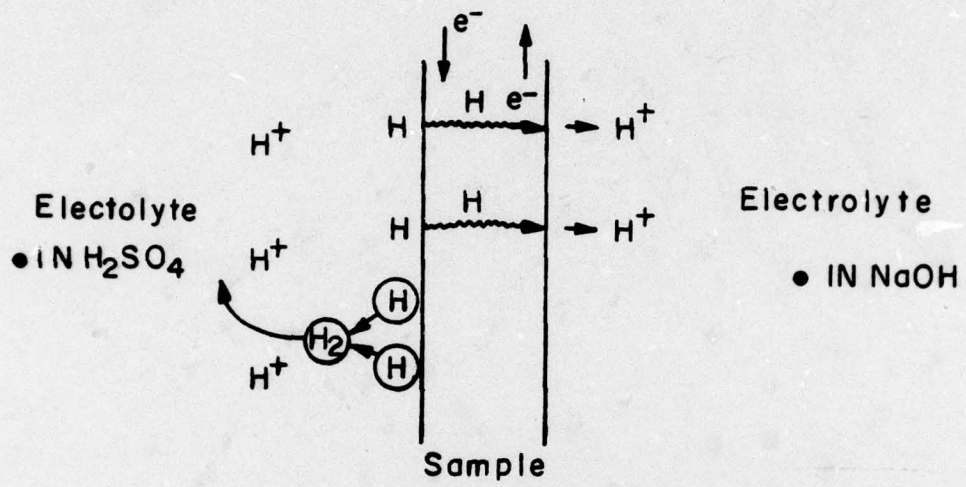

FIGURE 3. The permeation experiment in illustrated format.

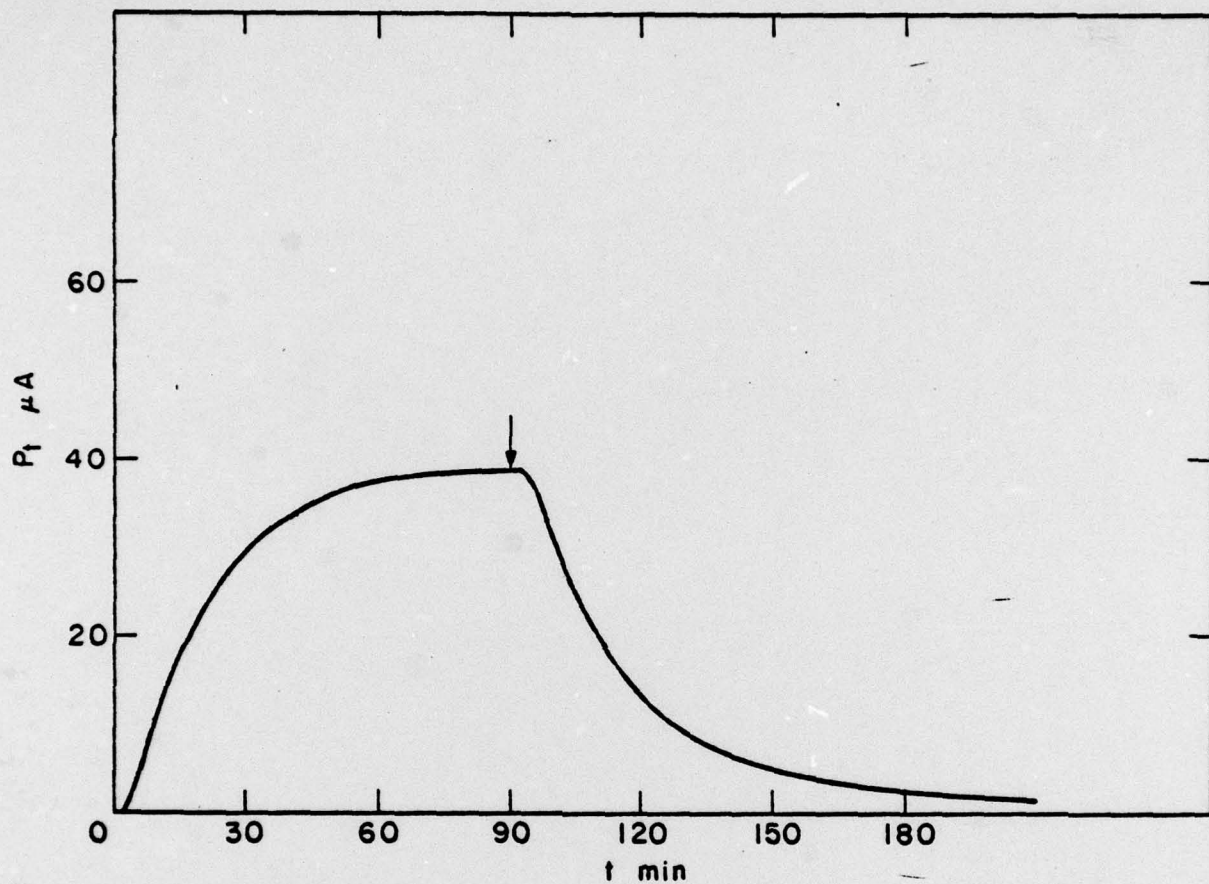

FIGURE 4. Typical permeation transient for an unstrained polycrystalline palladium membrane.

The results of some of the experiments which are in progress on Ni 270 specimens are described in the following section. Additional work which is in progress but not sufficiently advanced at this point to warrant discussion will be treated in subsequent reports.

Results

In the following, we summarize the results of preliminary experiments performed on unstrained membranes with a view to evaluating the grain size dependence of the hydrogen permeation flux. In particular, we have chosen in this case to examine nickel membranes prepared from specimens heat treated similarly to samples found susceptible to embrittlement in earlier work [1][2]. Hence, specimens were encapsulated in the presence of a nitrogen atmosphere and heat treated at 1000°C for various periods of time, thereby producing membranes with grain size in the range 200 - 800 μ m. Typical rise transients are shown in Figure 5 and 6 and a tabulation of measured diffusion coefficients (D_H), steady state permeation flux (J_∞), and concentration (C_O) is given in Table I.

TABLE I: Summary of Preliminary Permeation Data

<u>Grain Diameter (μm)</u>	<u>J_∞ (μA)</u>	<u>C_O (g·atom/cm³)</u>	<u>D_H (cm²/sec)</u>
200	0.29	8.55×10^{-5}	6.85×10^{-10}
600	0.15	1.21×10^{-4}	2.40×10^{-10}
800	0.37	3.30×10^{-4}	2.06×10^{-10}

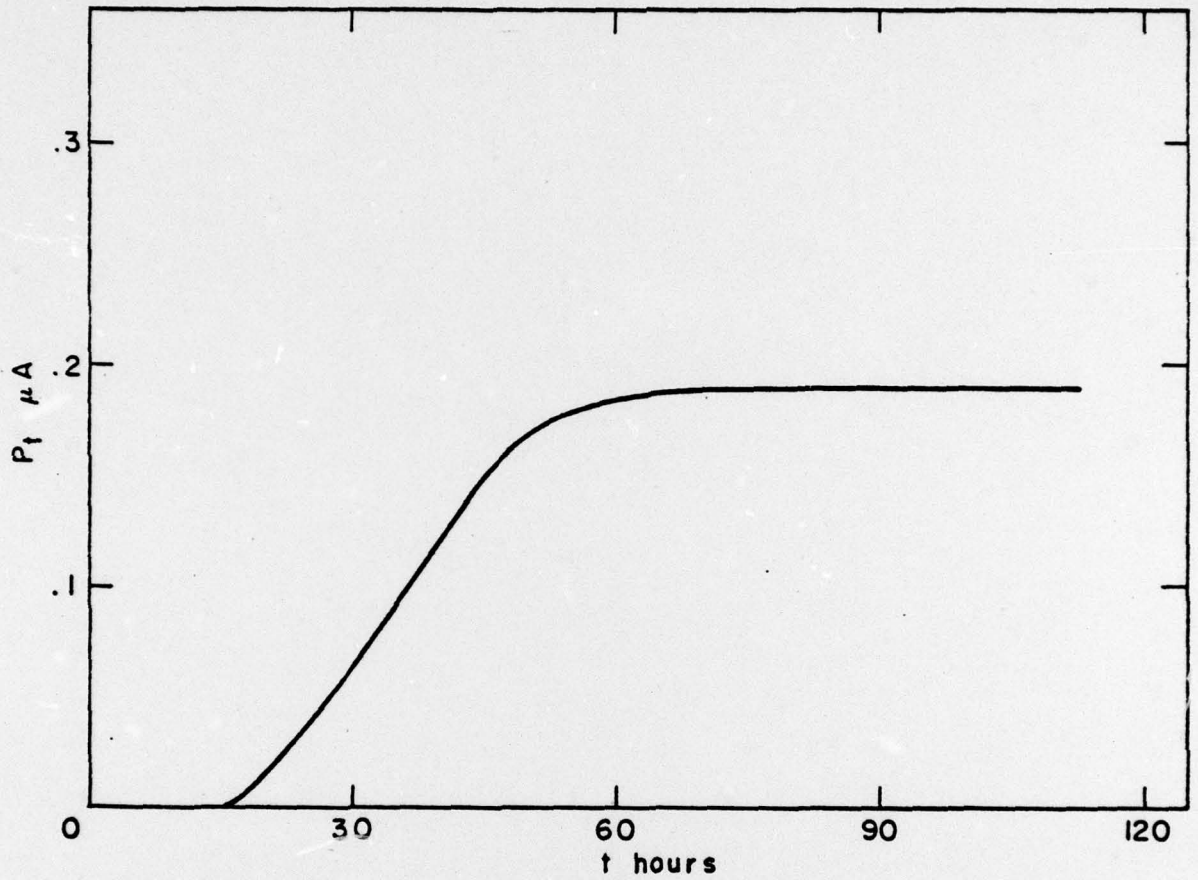

FIGURE 5. Permeation transient for 200 μ m grain-size nickel membrane. The anodically polarized side of the membrane was electrolessly plated with a thin palladium layer in order to reduce the background oxidation current, charging current 12.5 mA/cm².

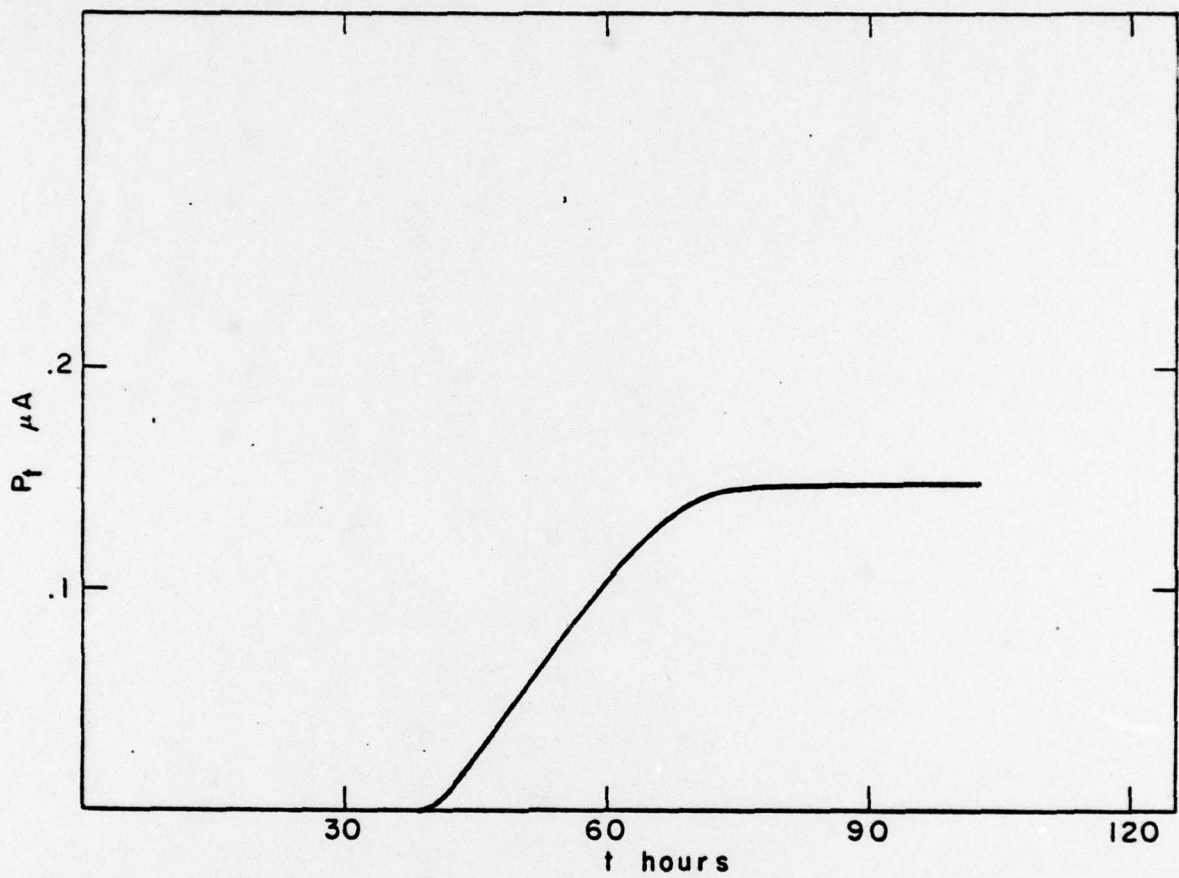

FIGURE 6. Rise transient for 600 μ m grain-size nickel specimens. Charging current 12.5 mA/cm².

It seems to us premature at this stage to comment in detail on these data. It might be worth noting, however, that the diffusion coefficients which have been observed are of a magnitude typical of lattice diffusion and not grain boundary diffusion, the latter of which one might expect to be somewhat higher. Robertson [17] and more recently Fiore et al. [18] have reported somewhat similar observations in permeation experiments performed using molecular and electrochemical hydrogen sources, respectively. This finding, which is still being pursued in our laboratory, suggests by implication that the transport of hydrogen by mobile dislocations may have contributed significantly to the ingress of hydrogen during experiments such as those described earlier [1][2]. We will, of course, examine this hypothesis in detailed experiments utilizing the straining cell which is described in Figure 2. The work will be treated in subsequent reports.

Concluding Remarks

This report is intended to summarize activities pursued during the first year of a program directed toward an evaluation of the susceptibility of nickel and nickel-base alloys to embrittlement by cathodically produced hydrogen. Preliminary results suggest that hydrogen permeation in unstrained membranes occurs by lattice diffusion rather than by alternate short circuiting mechanisms. Work is in progress to evaluate the contribution of dislocation transport to the permeation flux.

References

1. R.M. Latanision and H. Opperhauser, Jr., Met. Trans. 5, 483 (1974).
2. R.M. Latanision and H. Opperhauser, Jr., Met. Trans. 6A, 233 (1975).
3. D. van Rooyen, Corrosion, 31, 327 (1975).
4. R.D. Kane, M. Watkins, D.F. Jacobs, and G.L. Hancock, Corrosion, 33, 309, 1977.
5. R.D. Kane and B.J. Berkowitz, Private Communication, October 1978.
6. R.M. Latanision, O.H. Gastine, and C.R. Compeau, First Technical Report to ONR (January 1978). To be published in Proc. Symposium on Environment Sensitive Fracture of Engineering Materials, Z.A. Foroulis, ed., in press.
7. R.M. Latanision and H. Opperhauser, Jr., Proc. 3rd International Conference on Strength of Metals and Alloys, Vol. 1, 472 (1973).
8. J.K. Tien, A.W. Thompson, I.M. Bernstein and R.J. Richards, Met. Trans., 7A, 821 (1976).
9. H.H. Johnson and J.P. Hirth, Met. Trans., 7A, 1543 (1976).
10. R.M. Latanision and R.W. Staehle, Scripta Met., 2, 667 (1968).
11. A.H. Windle and G.C. Smith, Metal Science Journal, 2, 187 (1968).
12. E. Eichenauer, Mem. Sci. Rev. Met., 57, 943 (1960).
13. Y. Ebisuzaki, W.J. Kass and M. O'Keefe, J. Chem. Phys., 46, 1378 (1967).
14. M.A. Devanathan and Z. Stachurski, Proc. Roy. Soc., A270, 90 (1962).
15. T. Nambodhiri and L. Nanis, Acta Met., 21, 663 (1973).
16. J.G. Early, Acta Met. 26, 1215 (1978).
17. W.M. Robertson, Z. Metallk., 64, 436 (1973).
18. N.F. Fiore, A. Atrens and D. Mezzanotte, Paper presented at Fall Meeting of AIME, St. Louis, October 1978.

BASIC DISTRIBUTION LIST

Technical and Summary Reports

April 1978

<u>Organization</u>	<u>Copies</u>	<u>Organization</u>	<u>Copies</u>
Defense Documentation Center Cameron Station Alexandria, VA 22314	12	Naval Air Propulsion Test Center Trenton, NJ 08628 ATTN: Library	1
Office of Naval Research Department of the Navy 800 N. Quincy Street Arlington, VA 22217		Naval Construction Battalion Civil Engineering Laboratory Port Hueneme, CA 93043 ATTN: Materials Division	1
ATTN: Code 471	1	Naval Electronics Laboratory San Diego, CA 92152 ATTN: Electron Materials Sciences Division	1
Code 102	1		
Code 470	1		
Commanding Officer Office of Naval Research Branch Office Building 114, Section D 666 Summer Street Boston, MA 02210	1	Naval Missile Center Materials Consultant Code 3312-1 Point Mugu, CA 92041	1
Commanding Officer Office of Naval Research Branch Office 536 South Clark Street Chicago, IL 60605	1	Commanding Officer Naval Surface Weapons Center White Oak Laboratory Silver Spring, MD 20910 ATTN: Library	1
Office of Naval Research San Francisco Area Office 760 Market Street, Room 447 San Francisco, CA 94102	1	David W. Taylor Naval Ship Research and Development Center Materials Department Annapolis, MD 21402	1
Naval Research Laboratory Washington, DC 20375		Naval Undersea Center San Diego, CA 92132 ATTN: Library	1
ATTN: Codes 6000	1	Naval Underwater System Center Newport, RI 02840 ATTN: Library	1
6100	1		
6300	1		
6400	1		
2627	1	Naval Weapons Center China Lake, CA 93555 ATTN: Library	1
Naval Air Development Center Code 302 Warminster, PA 18964 ATTN: Mr. F. S. Williams	1	Naval Postgraduate School Monterey, CA 93940 ATTN: Mechanical Engineering Department	1

BASIC DISTRIBUTION LIST (cont'd)

<u>Organization</u>	<u>Copies</u>	<u>Organization</u>	<u>Copies</u>
Naval Air Systems Command Washington, DC 20360 ATTN: Codes 52031 52032	1	NASA Headquarters Washington, DC 20546 ATTN: Code:RRM	1
Naval Sea System Command Washington, DC 20362 ATTN: Code 035	1	NASA Lewis Research Center 21000 Brookpark Road Cleveland, OH 44135 ATTN: Library	1
Naval Facilities Engineering Command Alexandria, VA 22331 ATTN: Code 03	1	National Bureau of Standards Washington, DC 20234 ATTN: Metallurgy Division Inorganic Materials Div.	1 1
Scientific Advisor Commandant of the Marine Corps Washington, DC 20380 ATTN: Code AX	1	Director Applied Physics Laboratory University of Washington 1013 Northeast Forthieth Street Seattle, WA 98105	1
Naval Ship Engineering Center Department of the Navy Washington, DC 20360 ATTN: Code 6101	1	Defense Metals and Ceramics Information Center Battelle Memorial Institute 505 King Avenue Columbus, OH 43201	1
Army Research Office P.O. Box 12211 Triangle Park, NC 27709 ATTN: Metallurgy & Ceramics Program	1	Metals and Ceramics Division Oak Ridge National Laboratory P.O. Box X Oak Ridge, TN 37380	1
Army Materials and Mechanics Research Center Watertown, MA 02172 ATTN: Research Programs Office	1	Los Alamos Scientific Laboratory P.O. Box 1663 Los Alamos, NM 87544 ATTN: Report Librarian	1
Air Force Office of Scientific Research Bldg. 410 Bolling Air Force Base Washington, DC 20332 ATTN: Chemical Science Directorate Electronics & Solid State Sciences Directorate	1 1	Argonne National Laboratory Metallurgy Division P.O. Box 229 Lemont, IL 60439	1 1
Air Force Materials Laboratory Wright-Patterson AFB Dayton, OH 45433	1	Brookhaven National Laboratory Technical Information Division Upton, Long Island New York 11973 ATTN: Research Library	1
Library Building 50, Rm 134 Lawrence Radiation Laboratory Berkeley, CA	1	Office of Naval Research Branch Office 1030 East Green Street Pasadena, CA 91106	1

C
April 1978

SUPPLEMENTARY DISTRIBUTION LIST

Technical and Summary Reports

Dr. T. R. Beck
Electrochemical Technology Corporation
10035 31st Avenue, NE
Seattle, Washington 98125

Professor I. M. Bernstein
Carnegie-Mellon University
Schenley Park
Pittsburgh, Pennsylvania 15213

Professor H. K. Birnbaum
University of Illinois
Department of Metallurgy
Urbana, Illinois 61801

Dr. Otto Buck
Rockwell International
1049 Camino Dos Rios
P.O. Box 1085
Thousand Oaks, California 91360

Dr. David L. Davidson
Southwest Research Institute
8500 Culebra Road
P.O. Drawer 28510
San Antonio, Texas 78284

Dr. D. J. Duquette
Department of Metallurgical Engineering
Rensselaer Polytechnic Institute
Troy, New York 12181

Professor R. T. Foley
The American University
Department of Chemistry
Washington, D.C. 20016

Mr. G. A. Gehring
Ocean City Research Corporation
Tennessee Avenue & Beach Thorofare
Ocean City, New Jersey 08226

Dr. J. A. S. Green
Martin Marietta Corporation
1450 South Rolling Road
Baltimore, Maryland 21227

Professor R. H. Heidersbach
University of Rhode Island
Department of Ocean Engineering
Kingston, Rhode Island 02881

Professor H. Herman
State University of New York
Material Sciences Division
Stony Brook, New York 11794

Professor J. P. Hirth
Ohio State University
Metallurgical Engineering
Columbus, Ohio 43210

Dr. D. W. Hoepfner
University of Missouri
College of Engineering
Columbia, Missouri 65201

Dr. E. W. Johnson
Westinghouse Electric Corporation
Research and Development Center
1310 Beulah Road
Pittsburgh, Pennsylvania 15235

Professor R. M. Latanision
Massachusetts Institute of Technology
77 Massachusetts Avenue
Room E19-702
Cambridge, Massachusetts 02139

Dr. F. Mansfield
Rockwell International Science Center
1049 Camino Dos Rios
P.O. Box 1085
Thousand Oaks, California 91360

Professor A. E. Miller
University of Notre Dame
College of Engineering
Notre Dame, Indiana 46556

Dr. Jeff Perkins
Naval Postgraduate School
Monterey, California 93940

C
Apr 11 1978

SUPPLEMENTARY DISTRIBUTION LIST
(Continued)

Professor H. W. Pickering
Pennsylvania State University
Department of Material Sciences
University Park, Pennsylvania 16802

Professor R. W. Staehle
Ohio State University
Department of Metallurgical Engineering
Columbus, Ohio 43210

Dr. E. A. Starke, Jr.
Georgia Institute of Technology
School of Chemical Engineering
Atlanta, Georgia 30332

Dr. Barry C. Syrett
Stanford Research Institute
333 Ravenswood Avenue
Menlo Park, California 94025

Dr. R. P. Wei
Lehigh University
Institute for Fracture and
Solid Mechanics
Bethlehem, Pennsylvania 18015

Professor H. G. F. Wilsdorf
University of Virginia
Department of Materials Science
Charlottesville, Virginia 22903