

AD-A062 109

ARMY ENGINEER WATERWAYS EXPERIMENT STATION VICKSBURG MISS F/G 8/8
OUTLET STRUCTURE FOR MERAMEC LAKE, MERAMEC RIVER, MISSOURI. HYD--ETC(U)
OCT 78 B P FLETCHER
WES-TR-H-78-15

UNCLASSIFIED

NL

| OF |

AD
A062109

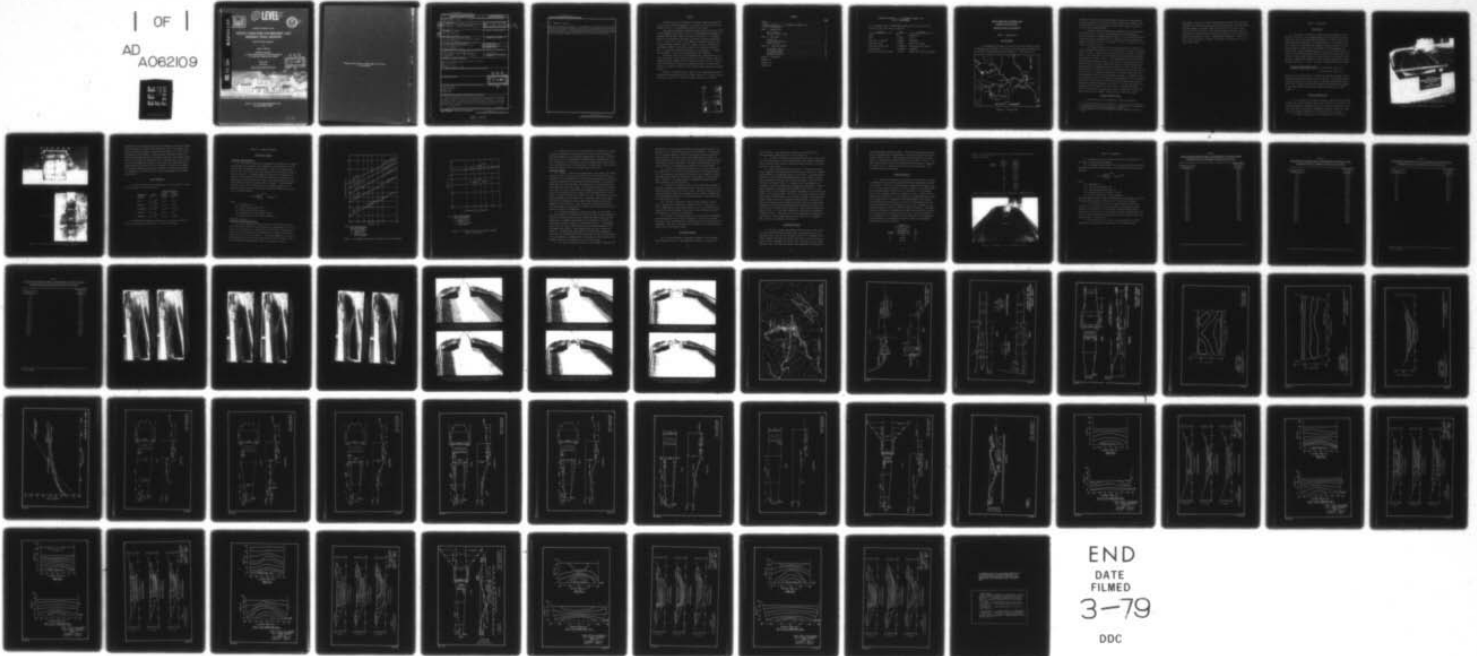

END
DATE
FILMED
3-79
DDC

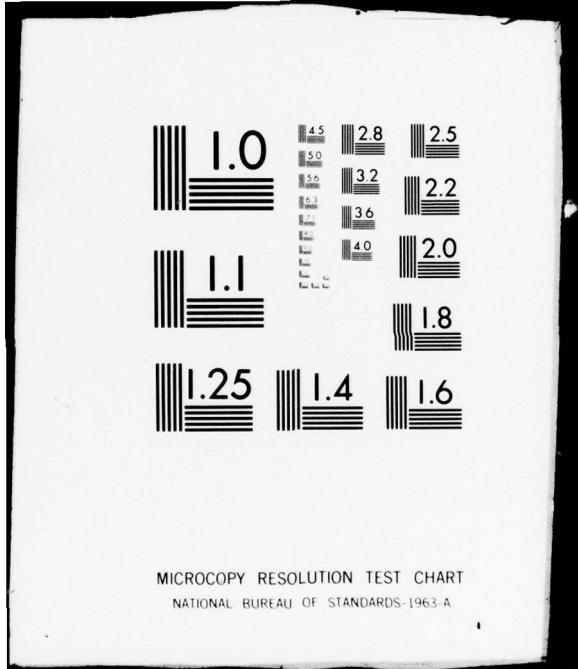

MICROCOPY RESOLUTION TEST CHART
NATIONAL BUREAU OF STANDARDS-1963-A

AD A062109

DDC FILE COPY

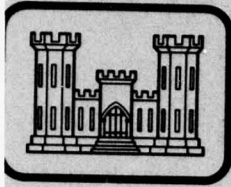

LEVEL II



TECHNICAL REPORT H-78-15

OUTLET STRUCTURE FOR MERAMEC LAKE MERAMEC RIVER, MISSOURI

Hydraulic Model Investigation

by

Bobby P. Fletcher

Hydraulics Laboratory

U. S. Army Engineer Waterways Experiment Station
P. O. Box 631, Vicksburg, Miss. 39180

October 1978

Final Report

Approved For Public Release; Distribution Unlimited

DDC
RECEIVED
DEC 14 1978
B

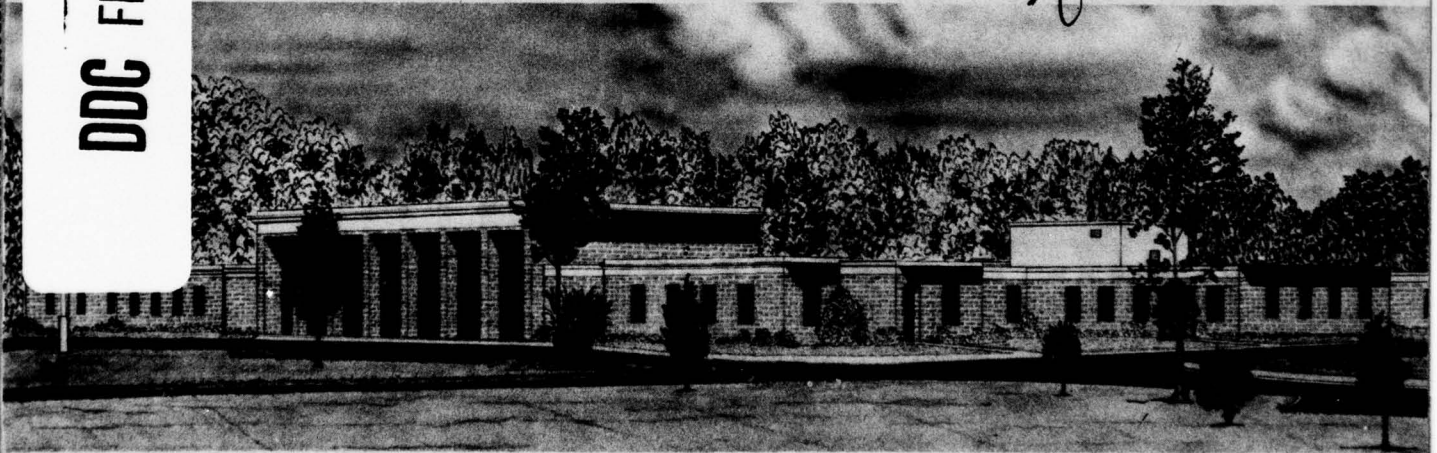

Prepared for U. S. Army Engineer District, St. Louis
St. Louis, Missouri 63101

12 11 032

Destroy this report when no longer needed. Do not return
it to the originator.

Unclassified

SECURITY CLASSIFICATION OF THIS PAGE (When Data Entered)

REPORT DOCUMENTATION PAGE		READ INSTRUCTIONS BEFORE COMPLETING FORM
1. REPORT NUMBER Technical Report H-78-15	2. GOVT ACCESSION NO.	3. RECIPIENT'S CATALOG NUMBER
4. TITLE (and Subtitle) OUTLET STRUCTURE FOR MERAMEC LAKE, MERAMEC RIVER, MISSOURI, Hydraulic Model Investigation.	5. TYPE OF REPORT & PERIOD COVERED Final report, Jul 74-Apr 76	6. PERFORMING ORG. REPORT NUMBER
7. AUTHOR(s) Bobby P. Fletcher	8. CONTRACT OR GRANT NUMBER(s)	
9. PERFORMING ORGANIZATION NAME AND ADDRESS U. S. Army Engineer Waterways Experiment Station Hydraulics Laboratory P. O. Box 631, Vicksburg, Mississippi 39180	10. PROGRAM ELEMENT, PROJECT, TASK AREA & WORK UNIT NUMBERS	
11. CONTROLLING OFFICE NAME AND ADDRESS U. S. Army Engineer District, St. Louis 210 N. 12th Street St. Louis, Missouri 63101	12. REPORT DATE October 1978	13. NUMBER OF PAGES 59
14. MONITORING AGENCY NAME & ADDRESS (if different from Controlling Office) WES-TR-H-78-15	15. SECURITY CLASS. (of this report) Unclassified	15a. DECLASSIFICATION/DOWNGRADING SCHEDULE
16. DISTRIBUTION STATEMENT (of this Report) Approved for public release; distribution unlimited. 64 p.		
17. DISTRIBUTION STATEMENT (of the abstract entered in Block 20, if different from Report)		
18. SUPPLEMENTARY NOTES		
19. KEY WORDS (Continue on reverse side if necessary and identify by block number) Hydraulic models Intake structures Meramec Lake Outlet works		
20. ABSTRACT (Continue on reverse side if necessary and identify by block number) Model investigation of the outlet works for Meramec Lake was concerned with verification and improvement of the hydraulic performance of the intake structure, transition, conduit, stilling basin, and exit channel. Hydraulic performance of the original and revised outlet works with 22- and 14-ft-wide horseshoe-shaped conduits, respectively, was investigated by means of 1:40- and 1:25.5-scale models. Flow distribution into the stilling basin was improved by (Continued)		

DDC
 RECEIVED
 DEC 14 1978
 B

DD FORM 1 JAN 73 1473

EDITION OF 1 NOV 65 IS OBSOLETE

Unclassified

SECURITY CLASSIFICATION OF THIS PAGE (When Data Entered)

038 100

elt

Unclassified

SECURITY CLASSIFICATION OF THIS PAGE(When Data Entered)

20. ABSTRACT (Continued).

Cont → providing a 38-ft-long horizontal apron immediately downstream of the 14-ft-wide conduit and placing the sidewalls 1 laterally in 16 longitudinally from the exit portal to the end sill. General discharge characteristics of the outlet works were defined as well as the minimum size and extent of stone protection required in the exit channel immediately downstream of the flared stilling basin. ↑

Unclassified

SECURITY CLASSIFICATION OF THIS PAGE(When Data Entered)

PREFACE

The model study of the Meramec Park outlet works was authorized by the Office, Chief of Engineers, U. S. Army, on 1 July 1974, at the request of the U. S. Army Engineer District, St. Louis.

The study was conducted during the period July 1974 to April 1976 in the Hydraulics Laboratory of the U. S. Army Engineer Waterways Experiment Station (WES) under the direction of Messrs. H. B. Simmons, Chief of the Hydraulics Laboratory, and under the general supervision of J. L. Grace, Jr., Chief of the Hydraulic Structures Division, and J. Bohan (former employee) and N. R. Oswalt, Chiefs of the Spillways and Channels Branch. The project engineer for the model study was Mr. B. P. Fletcher, assisted by Messrs. E. D. Rothwell, W. A. Walker, and B. Perkins. This report was prepared by Mr. Fletcher.

During the course of the investigation, Mr. Malcolm Dove of the Lower Mississippi Valley Division and Messrs. Charles Denzel, Robert L. Barkau, Marlin W. Hornak, and Ms. Nancy H. Hsieh of the St. Louis District visited WES to discuss the program and results of model tests, observe the model in operation, and correlate these results with design studies.

Directors of WES during the conduct of the investigation and the preparation and publication of this report were COL G. H. Hilt, CE, and COL John L. Cannon, CE. Technical Director was Mr. F. R. Brown.

ACCESSION FOR	
NTIS	WETS Section <input checked="" type="checkbox"/>
DOC	WETS Section <input type="checkbox"/>
UNCLASSIFIED	<input type="checkbox"/>
JUSTIFICATION	
BY	
DISTRIBUTION/AVAILABILITY CODES	
Dist	or SPECIAL
A	

CONTENTS

	<u>Page</u>
PREFACE	1
CONVERSION FACTORS, U. S. CUSTOMARY TO METRIC (SI)	
UNITS OF MEASUREMENT	3
PART I: INTRODUCTION	4
The Prototype	4
Purpose of Model Study	5
PART II: THE MODEL	7
Description	7
Design Considerations	7
Scale Relations	10
PART III: TESTS AND RESULTS	11
22-ft-Wide Conduit	11
14-ft-Wide Conduit	15
Recommended Design	16
Riprap Protection	17
PART IV: DISCUSSION	19
TABLES 1-4	
PHOTOS 1-12	
PLATES 1-30	

CONVERSION FACTORS, U. S. CUSTOMARY TO METRIC (SI)
UNITS OF MEASUREMENT

U. S. customary units of measurement used in this report can be converted to metric (SI) units as follows:

<u>Multiply</u>	<u>By</u>	<u>To Obtain</u>
inches	25.4	millimetres
feet	0.3048	metres
miles (U. S. statute)	1.609344	kilometres
feet per second	0.3048	metres per second
cubic feet per second	0.02831685	cubic metres per second
pounds (mass)	0.4535924	kilograms
feet per second per second	0.3048	metres per second per second

OUTLET STRUCTURE FOR MERAMEC LAKE

MERAMEC RIVER, MISSOURI

Hydraulic Model Investigation

PART I: INTRODUCTION

The Prototype

1. The Meramec River Basin is located in the east-central portion of Missouri and is bounded on the north by the Missouri River Basin and on the east by the Mississippi River (Figure 1). The dam will be

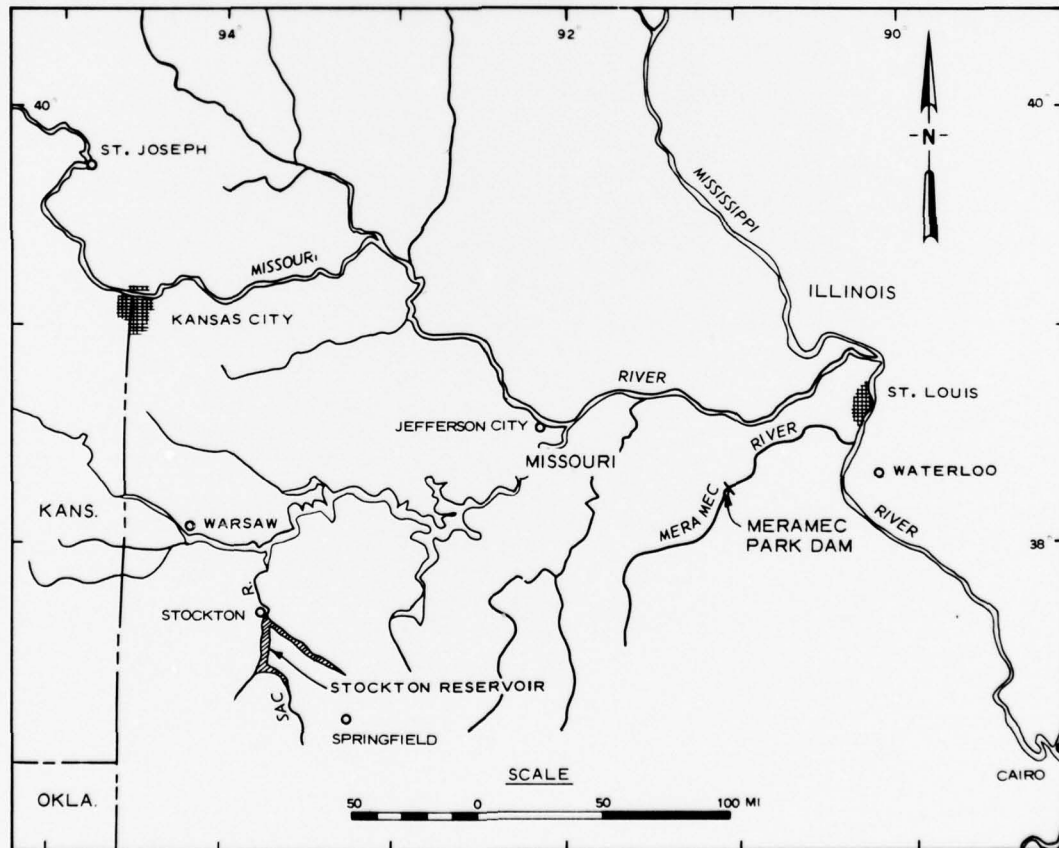

Figure 1. Vicinity map

located in Crawford and Washington Counties, Missouri, approximately 50 miles* southwest of St. Louis and will provide flood control, downstream releases for water-quality control, water supply, recreation, and fish and wildlife benefits.

2. The dam, outlet structure, and spillway will be located near river mile 108.7. The main dam embankment will be approximately 3,000 ft long with a maximum height of 183 ft. The uncontrolled 600-ft-long broad-crested spillway crest (el 709**) will pass a maximum discharge of 203,800 cfs at a pool elevation of 733.5. The top of the dam will be located at el 739.

3. Discharges through the outlet structure will be required for normal reservoir operation when the reservoir pool is below the spillway crest (el 709). A general plan and profile of the structure is shown in Plates 1 and 2 and details of the intake transition and stilling basin are presented in Plates 3 and 4. The intake structure will be provided with a water temperature control weir (el 655) located upstream of the conduit intake. The gated intake structure will contain two gate passages capable of discharging the flood release of 8,000 cfs, when the elevation of the reservoir surface is at the bottom of the flood control pool (el 675). A transition section will be provided between the two gate passages and the 14-ft-wide horseshoe conduit. A parabolic drop to the stilling basin will be provided at the downstream end of the conduit. The stilling basin will be of the conventional hydraulic-jump type designed for a maximum discharge of 8,000 cfs. The stilling basin's apron elevation will be located at el 558. The exit channel will have a 35-ft bottom width and 1V-on-3H side slopes. Riprap will provide protection for the exit channel invert and the 1V-on-3H side slopes.

Purpose of Model Study

4. The model tests were conducted to study the hydraulic

* A table of factors for converting U. S. customary units of measurement to metric (SI) units is presented on page 3.

** All elevations (el) cited herein are in feet referred to mean sea level.

performance of the outlet works including pressures and flow conditions throughout the intake structure, the transition, conduit, stilling basin, and exit channel. The model study was also utilized to observe wave action and current patterns in the exit area and to determine the size and extent of stone protection required for protection of the downstream channel side slopes and invert. Modifications, described in PART III of this report, were made to improve the hydraulic performance of the proposed outlet works.

PART II: THE MODEL

Description

5. Initially, a 1:40-scale, undistorted model (Figures 2 and 3) was used for study of the original design of the proposed outlet works. Sufficient area of the reservoir was reproduced to obtain natural flow conditions in the approach to the intake structure. The intake structure, conduit, and stilling basin sidewalls were constructed of transparent plastic to permit visual observation of flow throughout the outlet works. About midway through the study, the sponsor revised the design of the horseshoe-shaped conduit by reducing its width from 22 ft to 14 ft. Rather than reconstruct a major portion of the model it was decided to simulate the change in conduit width by changing the scale of the model from 1:40 to 1:25.5. This was accomplished by the following:

$$\frac{\text{Revised conduit width (14 ft)}}{\text{Original conduit width (22 ft)}} \times \text{Original model scale (40)} \\ = \text{Revised model scale (25.5)}$$

Water used in the operation of the model was supplied by pumps and discharges were measured by means of orifice meters. Water-surface elevations were obtained with point gages. Velocities were measured with a pitot tube. Current patterns were determined by observing the movement of dye injected into the water and confetti sprinkled on the water surface.

Design Considerations

6. In the design of the model, geometric similitude was preserved between model and prototype by means of an undistorted scale ratio. The accepted equations of hydraulic similitude, based on the Froudian relation, were used to express the mathematical relation between the dimensional and hydraulic quantities of the model and the prototype.

7. To make a valid study of flow conditions in the structure



Figure 2. The 1:40-scale model (looking upstream)

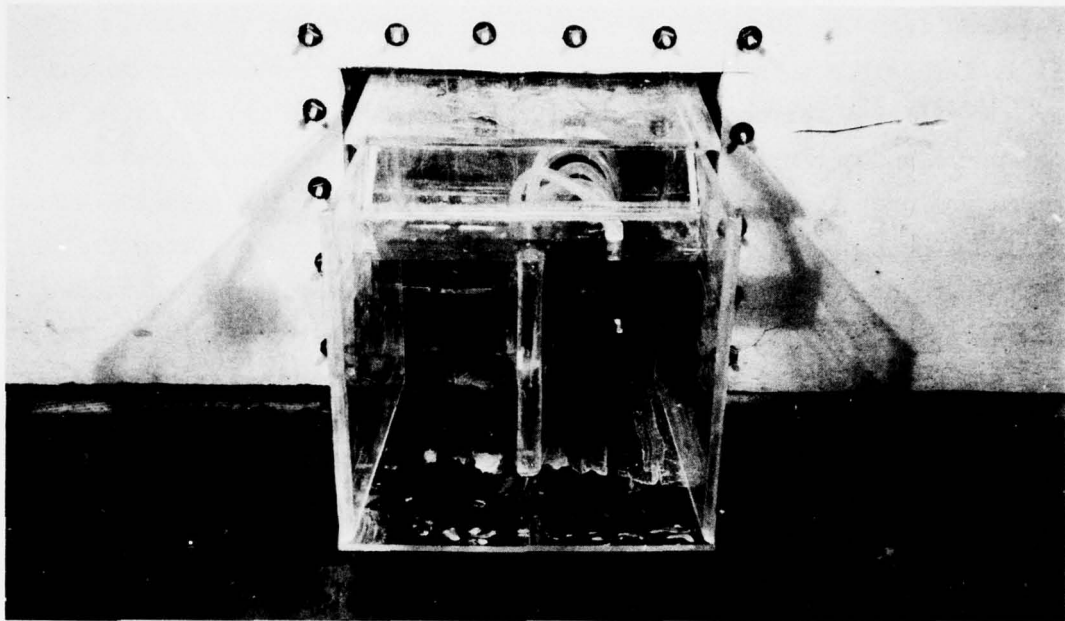

a. Intake

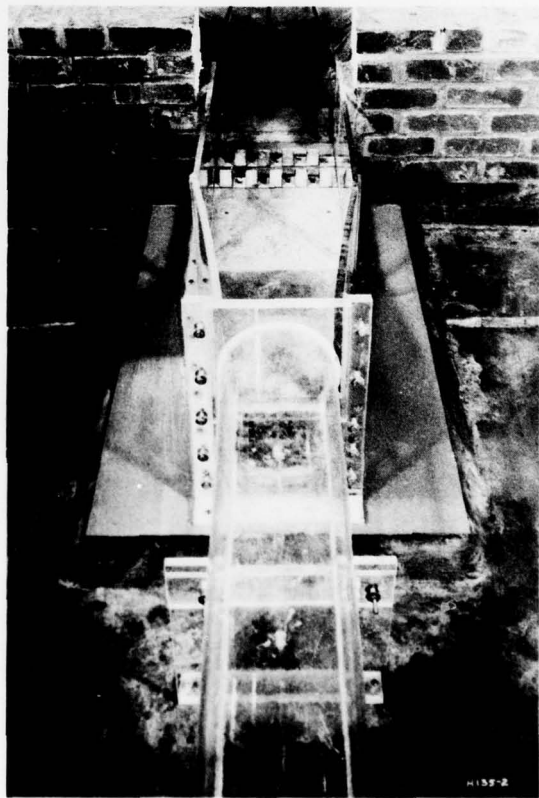

b. Outlet

Figure 3. Model intake and outlet, looking downstream

required that the prototype grade line be simulated in the model conduit. It is impossible to satisfy the requirements of both the Reynolds and Froude criteria for complete similitude when water is the fluid in both the model and the prototype. Since hydraulic similitude between the model and prototype was based on Froudian relations, the Reynolds number of flow in the model was lower than that of the prototype, with the result that the hydraulic resistance of the model was disproportionately higher than that anticipated in the prototype. Therefore, the length of the model conduit was reduced to compensate for the greater hydraulic resistance of the model relative to that anticipated in the prototype conduit.

Scale Relations

8. General relations for transference of the model data to prototype equivalents are presented below.

<u>Dimension</u>	<u>Ratio</u>	<u>Scale Relations</u>	
		<u>14-ft Conduit</u>	<u>22-ft Conduit</u>
Length	L_r	1:25.5	1:40
Time	$T_r = L_r^{1/2}$	1:5.05	1:6.32
Velocity	$V_r = L_r^{1/2}$	1:5.05	1:6.32
Discharge	$Q_r = L_r^{5/2}$	1:3,283	1:10,119
Pressure	$P_r = L_r$	1:25.5	1:40
Roughness	$N_r = L_r^{1/6}$	1:1.715	1:1.850

9. Quantitative transfer of model data to prototype equivalents by the scale relations listed above is considered reliable.

PART III: TESTS AND RESULTS

22-ft-Wide Conduit

Discharge characteristics

10. The intake structure was schematically simulated in the model and approach flow conditions were symmetrical and satisfactory for the entire range of discharges investigated. A plot of discharge versus head on the center line of the gate opening for various gate openings is shown in Figure 4. A general equation describing the discharge coefficient of the proposed outlet works was obtained by plotting the coefficients for each ratio of the areas or gate opening shown in Figure 4 versus percent of gate opening as shown in Figure 5. The following equation can be used for determining the discharge capacity of the proposed outlet works for various gate openings and heads on the center line of any gate opening.

$$Q = 0.68 \left(\frac{A_o}{A_t} \right)^{0.05} A_o (2gH_o)^{1/2}$$

where

Q = discharge, cfs

A_o = area of gate opening, ft²

A_t = area with gates fully open, ft

g = acceleration due to gravity, ft/sec²

H_o = head on center line of gate opening, ft

Transition, conduit, trajectory, and stilling basin

11. With a discharge of 8,000 cfs and a pool elevation of 709, flow exiting the conduit was concentrated as a standing wave in the center of the trajectory as it entered the stilling basin. Energy dissipation in the stilling basin was unbalanced as indicated by velocities measured over the end sill (Plate 5). Velocities measured 50 and 120 ft downstream from the end sill are presented as isovels in Plates 6 and 7. The anticipated tailwater rating curve is presented in Plate 8.

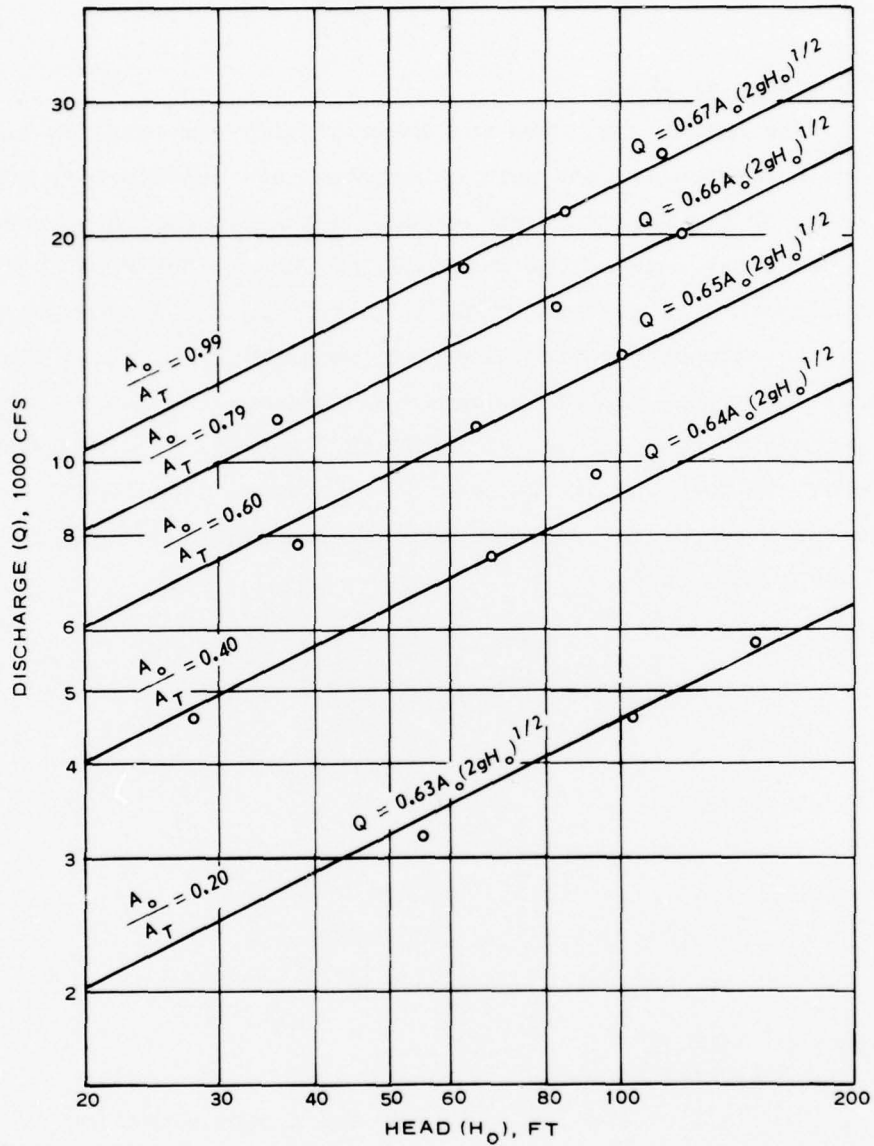
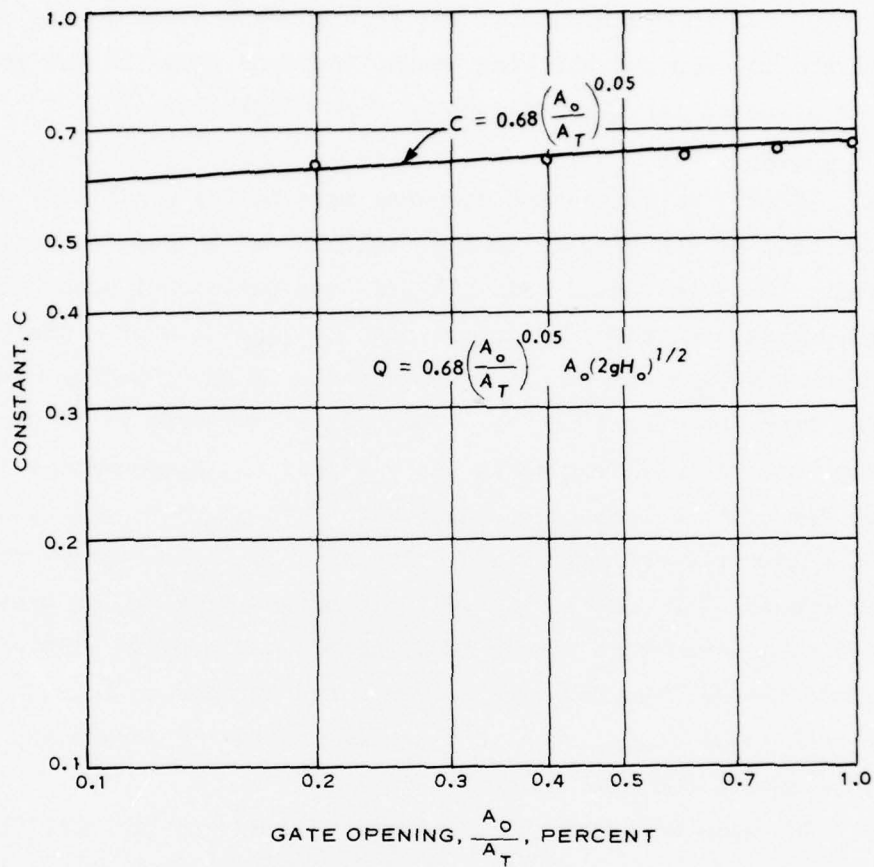

Figure 4. Discharge versus head on center line of gate opening



NOTE: DATA OBTAINED WITH
BOTH GATES OPENED
EQUAL DISTANCES

A_o = AREA OF GATE
OPENING, FT²

A_T = AREA WITH GATES
FULLY OPEN

Figure 5. Constant versus ratio of gate opening
area to total area

12. Observation of flow in the transition indicated that a standing wave was created by the intersection of the two jets issuing from the gate passages into the transition downstream of the pier or divider wall (Plate 3). The standing wave remained intact throughout the conduit and appeared to contribute to the flow concentration in the center of the parabolic drop and stilling basin. Adverse flows in the stilling basin were observed for all anticipated flow conditions.

Alternate designs

13. Efforts to reduce the standing wave in the conduit by streamlining the tail of the pier or divider wall in the transition were unsuccessful. Tests indicated that a 60-ft-long horizontal apron (Plate 9) installed downstream from the conduit exit and upstream of a trajectory would spread the flow and reduce the magnitude of the standing wave as it emerged from the outlet portal. The trajectory (type 2) of the parabolic drop into the stilling basin was designed to accommodate a velocity of 65 fps exiting from the conduit which was measured with a discharge of 13,000 cfs and a pool elevation of 675. Satisfactory stilling basin performance was observed for all discharges equal to or greater than 2,000 cfs; however, a severe eddy formed in the basin with discharges less than 2,000 cfs. The currents and turbulence in such an eddy are capable of moving rocks and debris that would abrade the stilling basin elements and sidewalls.

14. Attempts were made to eliminate the eddy in the stilling basin and improve the distribution of flow entering the basin during low flows by providing an adverse slope between the outlet portal and the beginning of a parabolic drop located at an elevation 4 ft above the outlet portal (type 3 trajectory) as shown in Plate 10. At discharges below 2,000 cfs, severe eddies formed in the stilling basin and flow performance was similar to that observed with the type 2 trajectory (Plate 9). During greater discharges, the adverse slope appeared to accentuate the standing wave at the conduit exit portal and contributed to the formation of a standing wave in the center of the trajectory that produced uneven flow distribution in the stilling basin.

15. The type 4 trajectory (Plate 11) was intended to improve the

distribution of flow entering the basin by depressing the sides of the parabolic drop to permit more flow along the sidewalls. It consisted of two identical parabolic curves for the center and side portions of the trajectory. The curves on the sides originated at a point 5 ft farther upstream than the origin of the center curve, thereby providing a depression along the sidewalls. The type 4 trajectory was only partially effective in eliminating the eddies in the stilling basin.

16. The type 5 trajectory was similar to the type 4 except that more depression of the invert was provided along the sidewalls (Plate 12). The depressed sides permitted additional flow along the sidewalls and significantly improved the hydraulic performance of the stilling basin. However, a few combinations of discharge and head produced severe eddies in the stilling basin.

17. The type 6 trajectory (Plate 13) also provided a depression along the sidewalls by originating the side curves at a point 20 ft upstream from the origin of the center curve. The type 6 trajectory provided satisfactory hydraulic performance for the larger discharges but was only partially effective in eliminating eddies in the stilling basin for flows below 2,000 cfs.

18. The type 7 trajectory (Plate 14) was developed from the type 6 trajectory by reducing the sidewall flare to 1 laterally in 16.45 longitudinally and the basin width to 40 ft. No eddies were observed at the low discharges and stilling basin performance appeared satisfactory for flows up to 13,000 cfs.

19. The type 8 trajectory (Plate 15) was obtained by eliminating the depressed sides of the type 7 trajectory. Flow in the stilling basin was evenly distributed and no adverse eddies were evident with low discharges. The type 8 trajectory was considered to be a satisfactory design for the 22-ft-wide conduit.

14-ft-Wide Conduit

20. The time required for emergency drawdown of the reservoir was increased by the U. S. Army Engineer District, St. Louis, from

30 to 120 days. This permitted a reduction in the width of the horseshoe-shaped conduit from 22 to 14 ft (Plate 16).

21. In order to simulate the reduction in the size of the conduit, the 1:40-scale model of the stilling basin and exit channel downstream from the conduit were revised to reproduce these portions of the outlet works at a 1:25.5 scale.

22. Model tests indicated the need for a 38-ft-long horizontal invert immediately downstream from the exit portal (Plate 16) to spread and distribute flow discharged from the exit portal. Horizontal aprons shorter than 38 ft permitted standing waves in the conduit to travel down the parabolic drop and into the stilling basin. Tests also indicated that a sidewall flare of 1 laterally in 16 longitudinally is necessary to provide satisfactory stilling basin performance. Observations of hydraulic performance with sidewalls that flared at a rate greater than 1 in 16 indicated an uneven distribution of flow and severe eddies in the stilling basin. The type 1 (14-ft-wide conduit) stilling basin (Plate 16) was installed in the model. Energy of the design discharge (8,000 cfs) was not dissipated satisfactorily, and severe currents and turbulence were observed downstream from the stilling basin. Satisfactory stilling basin performance was observed with flows below 5,000 cfs and no adverse eddies developed. Water-surface profiles are shown in Plate 17. Basic data obtained from the model are tabulated in Tables 1 and 2. Velocities for various discharges are presented in Plates 18-25. Wave heights along the side slopes for a discharge of 9,400 cfs are also indicated in Plate 25.

Recommended Design

23. The type 2 basin was developed from the type 1 basin (Plate 16) by extending the flared sidewall from the downstream end of the parabolic drop to the end sill as shown in Plate 26. Extension of the flared sidewalls increased the width of the basin at the end sill, reduced the unit discharge over the end sill, and induced a more stable hydraulic jump. No eddies or adverse flow conditions were observed in

the stilling basin during low flows. Flow in the exit channel was more evenly distributed and the magnitudes of the velocities and waves were reduced (Plates 27-30). Water-surface profiles through the stilling basin for discharges of 8,000 and 9,400 cfs are shown in Plate 26. The basic water-surface profile data obtained from the model are tabulated in Tables 3 and 4. Photos 1-12 show various flow conditions in the stilling basin and exit channel.

Riprap Protection

24. Tests were conducted to determine the minimum size and extent of riprap protection required downstream from the recommended stilling basin design. Initially, riprap having an average stone diameter (d_{50}) of 12 in. was placed $2d_{50}$ thick in the exit channel and was subjected to the following hydraulic conditions for a period of 1 hr (prototype): pool el 675, discharge 8,000 cfs, tailwater el 582.5. Failure was observed from the end sill to a point about 50 ft downstream from the end sill (riprap failure is regarded as any displacement of the stones). The riprap from the end sill to a point 65 ft downstream from the end sill was replaced with riprap having a d_{50} of 15 in. (scheme A). The scheme A riprap was stable for flows as large as 8,000 cfs. Additional tests were conducted to determine the riprap sizes required for protection of the channel downstream from the 15-in. stone. The following is a tabulation of the averages sizes and locations of the riprap protection required for discharges as large as 8,000 cfs and minimum anticipated tailwater elevations:

<u>Scheme</u>	Segment of Channel Relative to Distance Downstream of End Sill, ft	d_{50} in.
A	0-65	15
B	65-150	12
C	150-300	9

Based on the above average stone sizes, the following gradations are considered adequate:

<u>Scheme</u>	<u>Rock Diameter in.</u>	<u>Percent Finer by Weight</u>
A	28	85-100
	24	50-85
	15	15-50
	7	0-15
B	22	85-100
	19	50-85
	12	15-50
	5	0-15
C	17	85-100
	14	50-85
	9	15-50
	4	0-15

Figure 6 illustrates the extent of the recommended riprap protection.

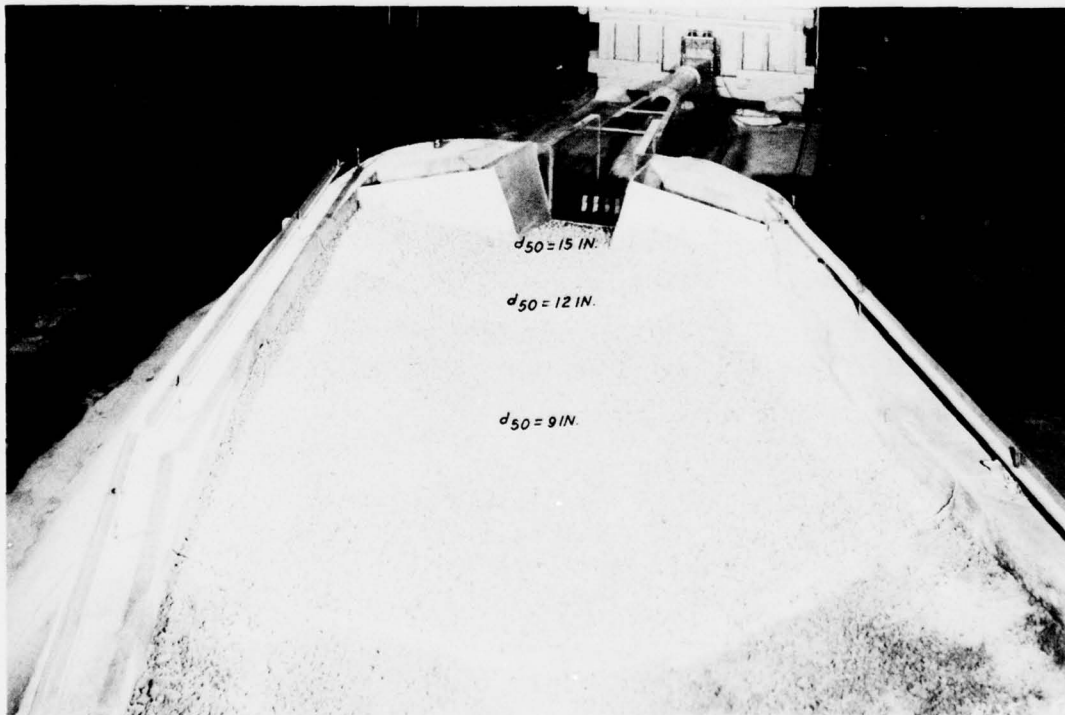

Figure 6. Recommended plan of riprap protection

PART IV: DISCUSSION

25. Approach flows to the intake structure were satisfactory for the range of discharges investigated.

26. Discharge characteristics of the outlet works associated with gate-controlled flows at the intake can be calculated by the following equation:

$$Q = 0.68 \left(\frac{A_o}{A_t} \right)^{0.05} A_o (2gH_o)^{1/2}$$

where

Q = discharge, cfs

A_o = area of gate opening, ft²

A_t = area with gates fully open, ft

g = acceleration due to gravity, ft/sec²

H_o = head on center line of gate opening, ft

The above equation can be used for determining the discharge for various gate openings and heads on the center line of any gate opening.

27. Flow exiting from the outlet portal was more evenly distributed on the parabolic drop by providing a 38-ft-long horizontal expansion downstream from the 14-ft-wide horseshoe-shaped conduit. Eddies that developed in the stilling basin during discharges less than 2,000 cfs were eliminated by extending the 1-on-16 sidewall flare from the exit portal to the end sill.

28. The minimum size and extent of stone protection required downstream from the flared stilling basin were determined also.

Table 1

Water-Surface Elevations, Type 1 Stilling Basin, 14-ft-Wide ConduitDischarge 8,000 cfs, Tailwater El 582.5, Pool El 675.0

<u>Distance from Exit Portal, ft</u>	<u>Water-Surface Elevation ft msl</u>
0.0	583.3
8.5	584.0
25.0	588.0
38.5	588.5
50.0	586.7
62.5	584.2
75.0	581.7
87.5	578.2
100.0	573.2
112.5	568.2
117.5	566.0
125.0	570.5
137.5	573.2
150.0	576.0
162.5	579.5
175.0	584.5
187.5	587.7
200.0	588.0
220.0	587.0

Table 2

Water-Surface Elevations, Type 1 Stilling Basin, 14-ft-Wide ConduitDischarge 9,400 cfs, Tailwater El 584.0, Pool El 709.0

<u>Distance from Exit Portal, ft</u>	<u>Water-Surface Elevation ft msl</u>
0.0	583.3
8.5	584.0
25.0	588.0
36.3	588.3
50.0	587.5
62.5	585.3
75.0	582.5
82.5	578.5
100.0	574.0
112.5	568.3
125.0	568.0
137.5	572.8
150.0	575.5
162.5	578.2
175.0	583.0
187.5	588.8
200.0	588.9
220.0	588.0

Table 3

Water-Surface Elevations, Type 2 Stilling Basin, 14-ft-Wide Conduit
Discharge 8,000 cfs, Tailwater El 582.5, Pool El 675.0

<u>Distance from Exit</u> <u>Portal, ft</u>	<u>Water-Surface</u> <u>Elevation</u> <u>ft msl</u>
25	588.5
50	587.0
75	581.5
100	573.7
115	566.7*
125	567.8
150	572.9
175	580.5
200	584.4
220	583.2

* Toe of jump.

Table 4

Water-Surface Elevations, Type 2 Stilling Basin, 14-ft-Wide Conduit
Discharge 9,400 cfs, Tailwater El 584.0, Pool El 709.0

<u>Distance from Exit Portal, ft</u>	<u>Water-Surface Elevation ft msl</u>
0.0	583.3
8.5	584.0
25.0	588.0
36.3	588.3
50.0	587.7
62.5	585.3
75.0	582.5
82.5	578.5
100.0	574.0
112.5	568.3
120.0	567.5*
150.0	573.5
175.0	582.5
200.0	586.0
220.0	585.5

* Toe of jump.

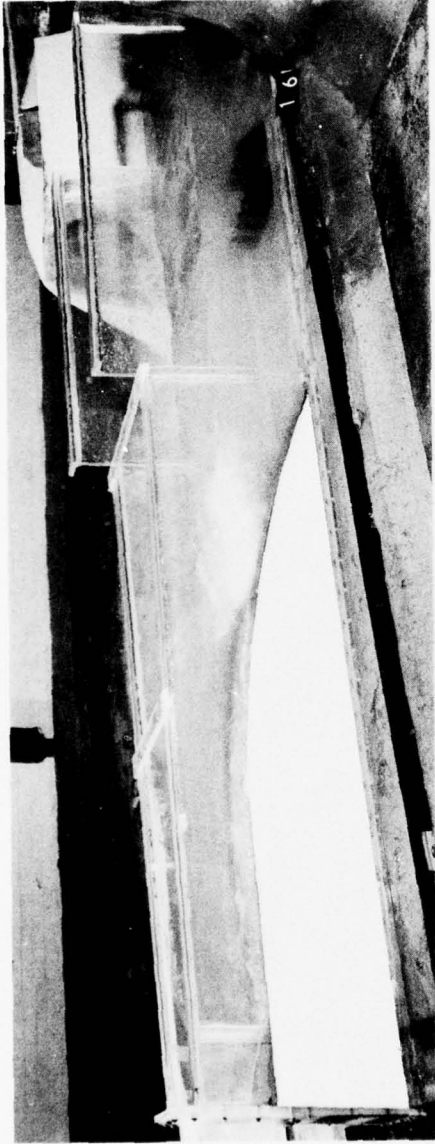

Photo 1. Flow conditions in stilling basin, recommended design;
pool el 675, tailwater el 573, discharge 300 cfs

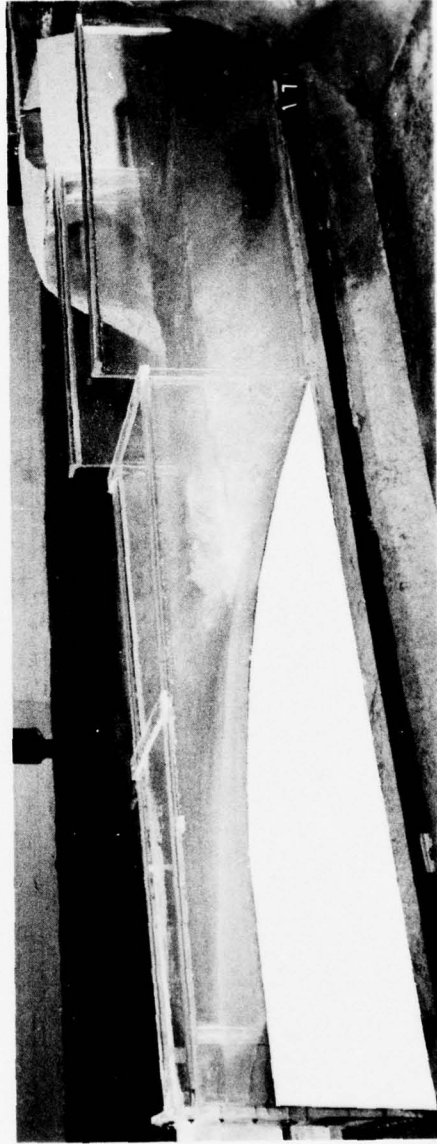

Photo 2. Flow conditions in stilling basin, recommended design;
pool el 600, tailwater el 577, discharge 2,000 cfs

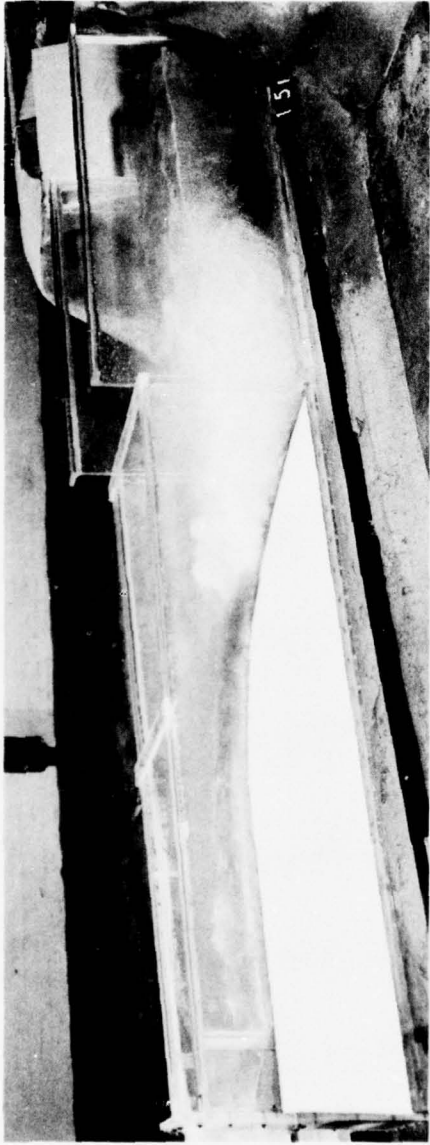

Photo 3. Flow conditions in stilling basin, recommended design;
pool el 675, tailwater el 577, discharge 2,000 cfs

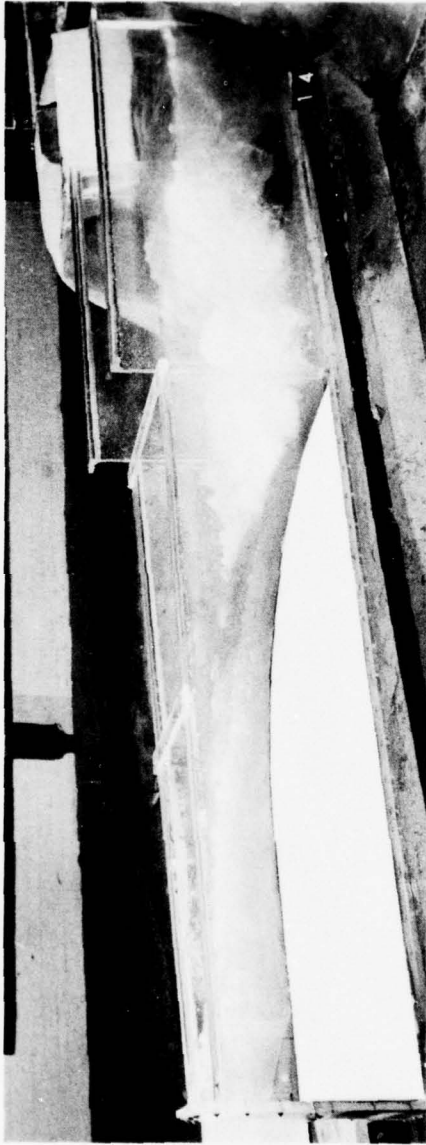

Photo 4. Flow conditions in stilling basin, recommended design;
pool el 675, tailwater el 580.5, discharge 5,000 cfs



Photo 5. Flow conditions in stilling basin, recommended design;
pool el 675, tailwater el 582.5, discharge 8,000 cfs

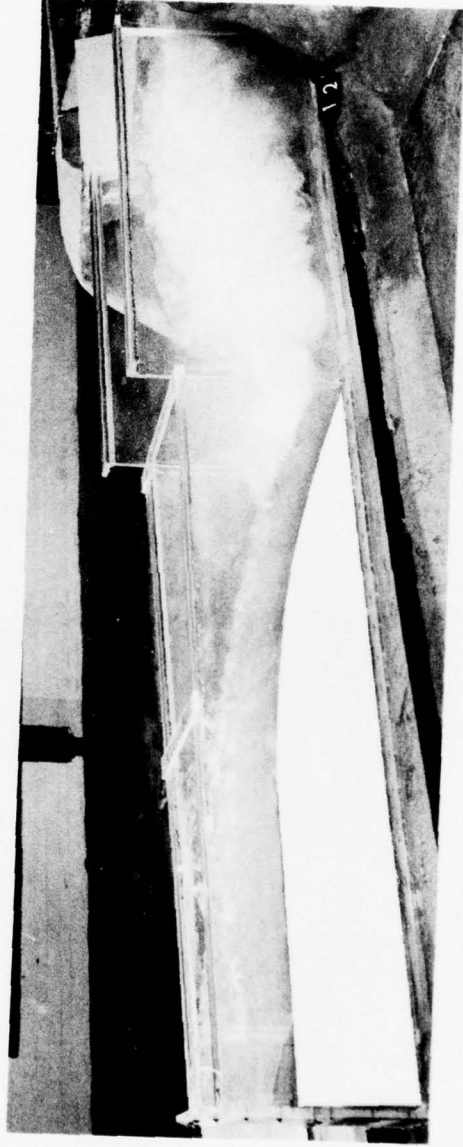

Photo 6. Flow conditions in stilling basin, recommended design;
pool el 709, tailwater el 584, discharge 9,400 cfs

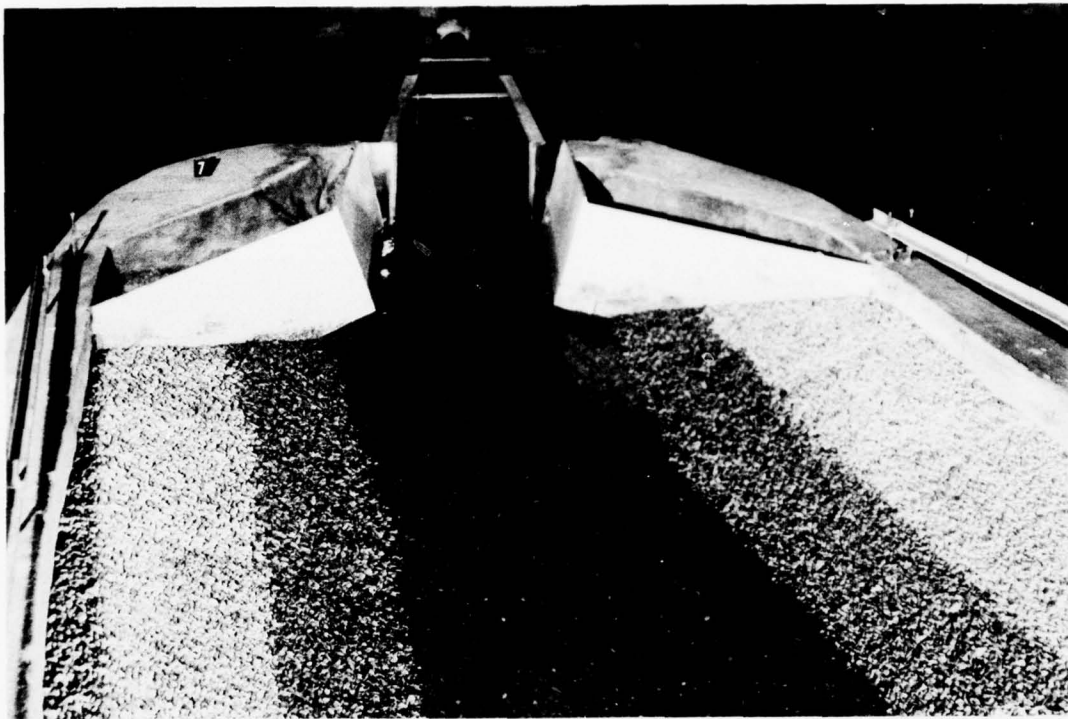

Photo 7. Flow conditions in exit channel, recommended design;
pool el 675, tailwater el 573, discharge 300 cfs

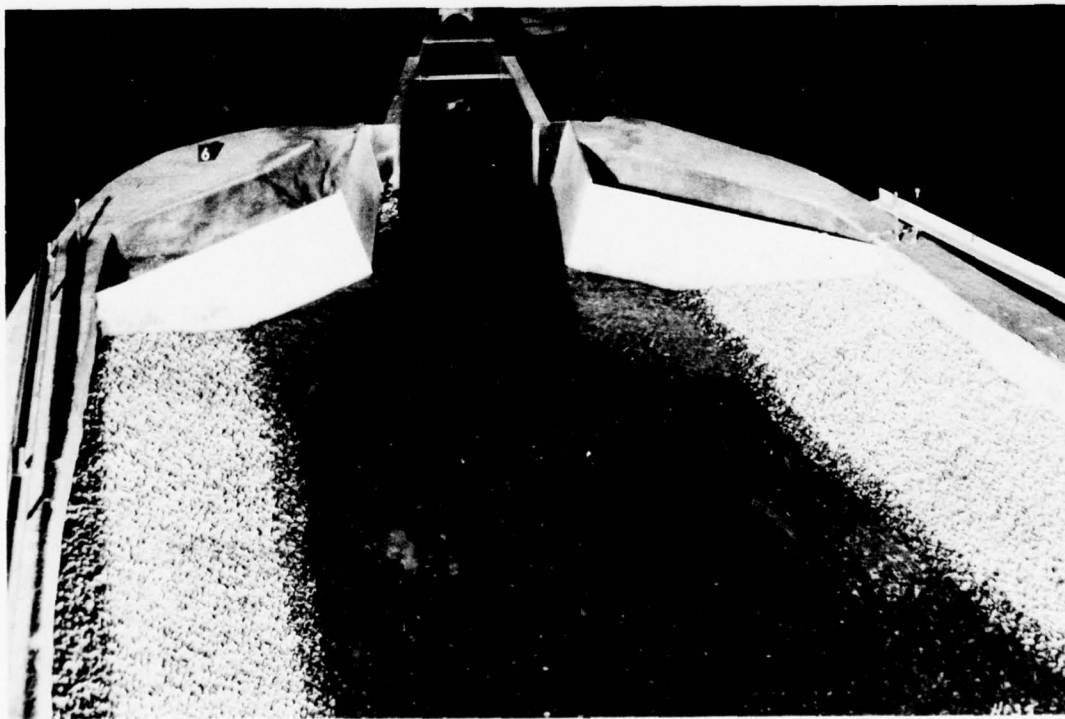

Photo 8. Flow conditions in exit channel, recommended design;
pool el 600, tailwater el 577, discharge 2,000 cfs

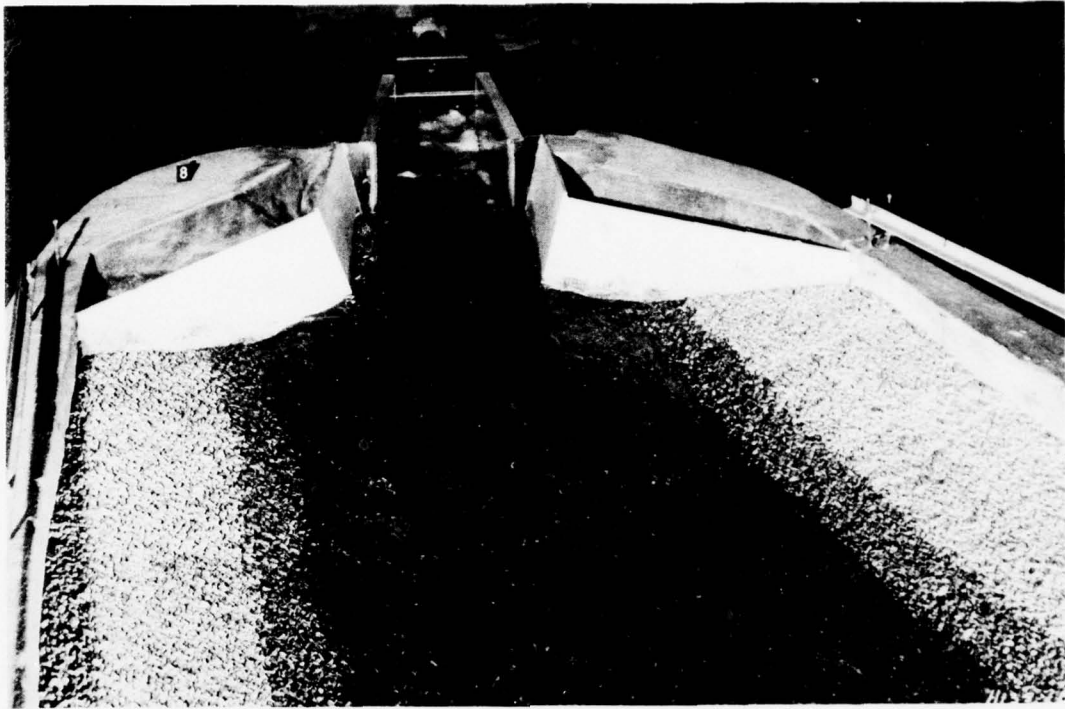

Photo 9. Flow conditions in exit channel, recommended design;
pool el 675, tailwater el 577, discharge 2,000 cfs



Photo 10. Flow conditions in exit channel, recommended design;
pool el 675, tailwater el 580.5, discharge 5,000 cfs



Photo 11. Flow conditions in exit channel, recommended design;
pool el 675, tailwater el 582.5, discharge 8,000 cfs

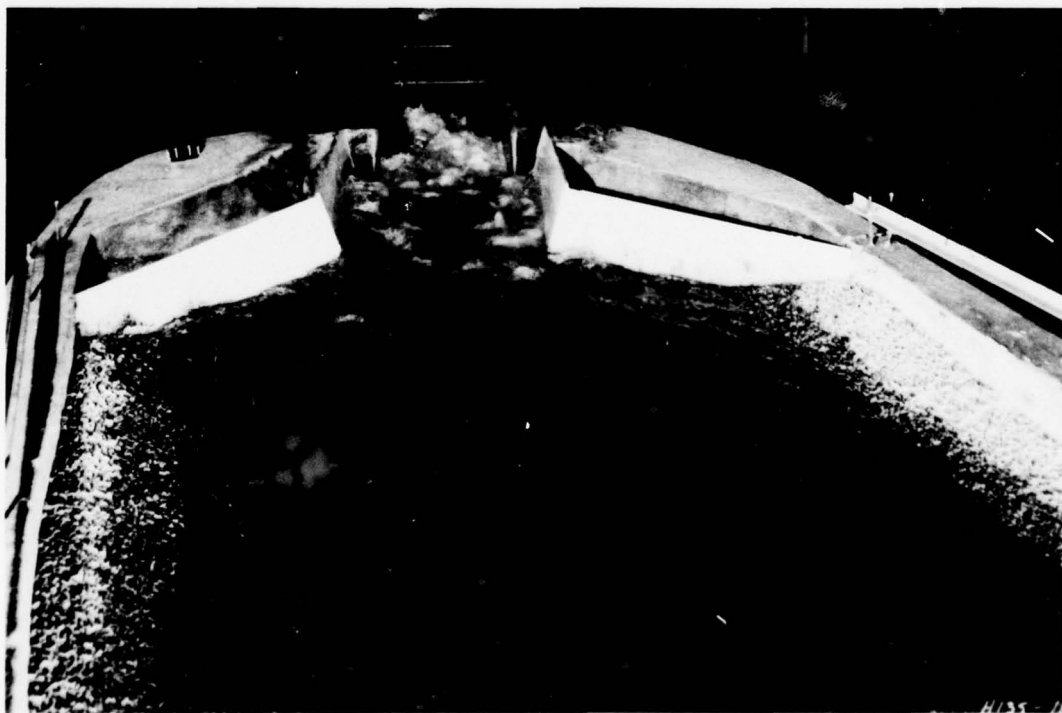
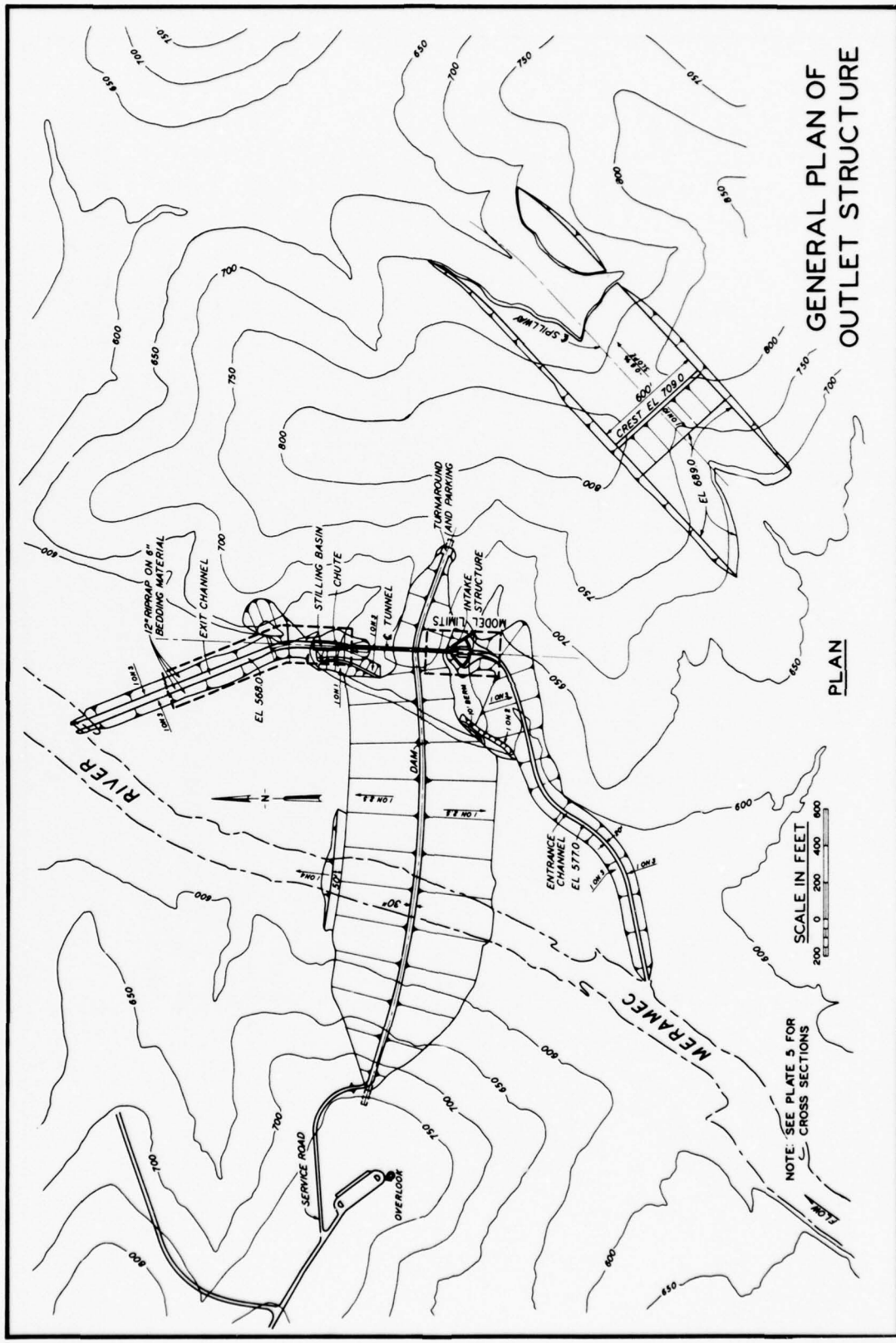

Photo 12. Flow conditions in exit channel, recommended design;
pool el 709, tailwater el 584, discharge 9,400 cfs



GENERAL PLAN OF
OUTLET STRUCTURE

PLAN

SCALE IN FEET
0 200 400 600

NOTE: SEE PLATE 5 FOR
CROSS SECTIONS

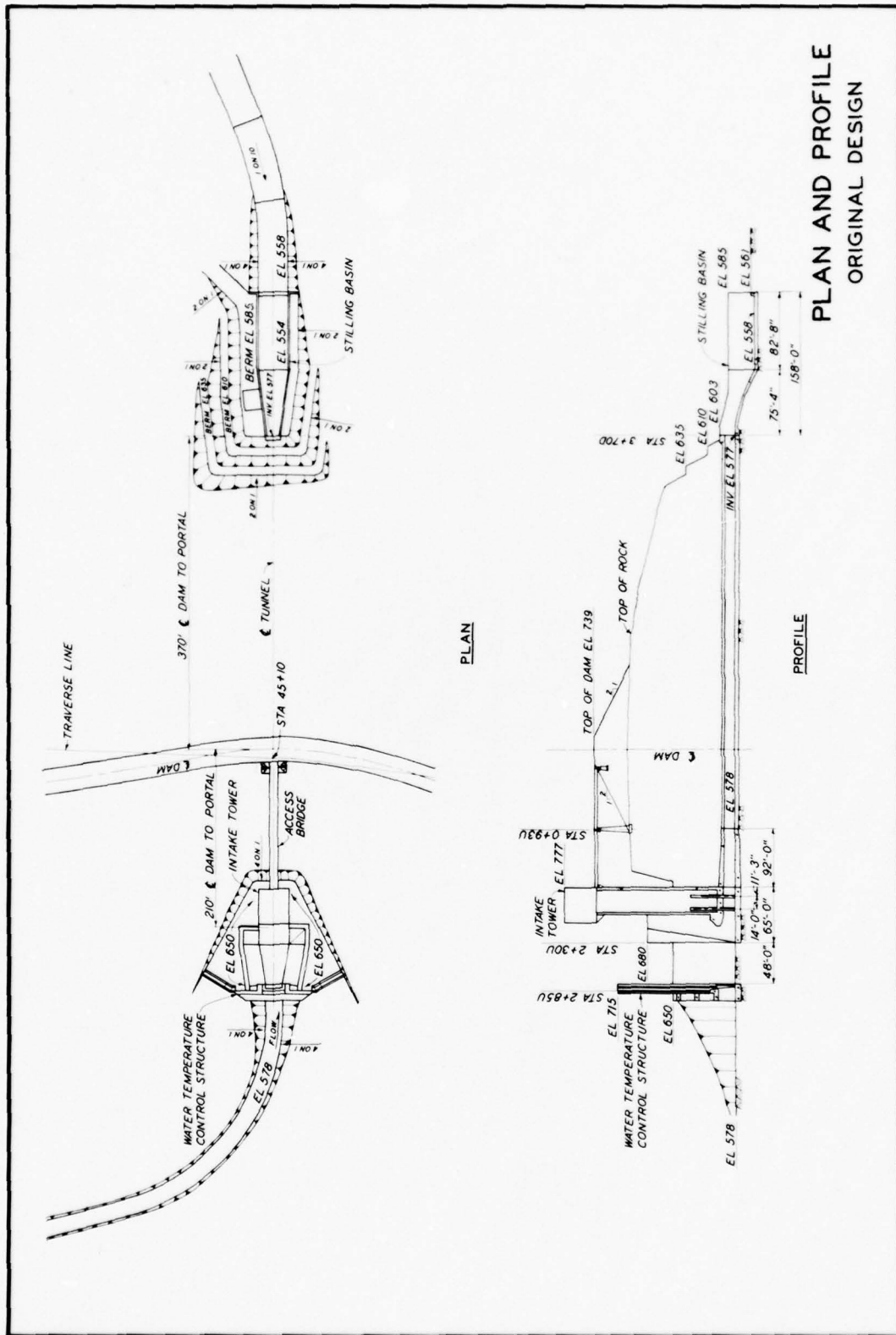
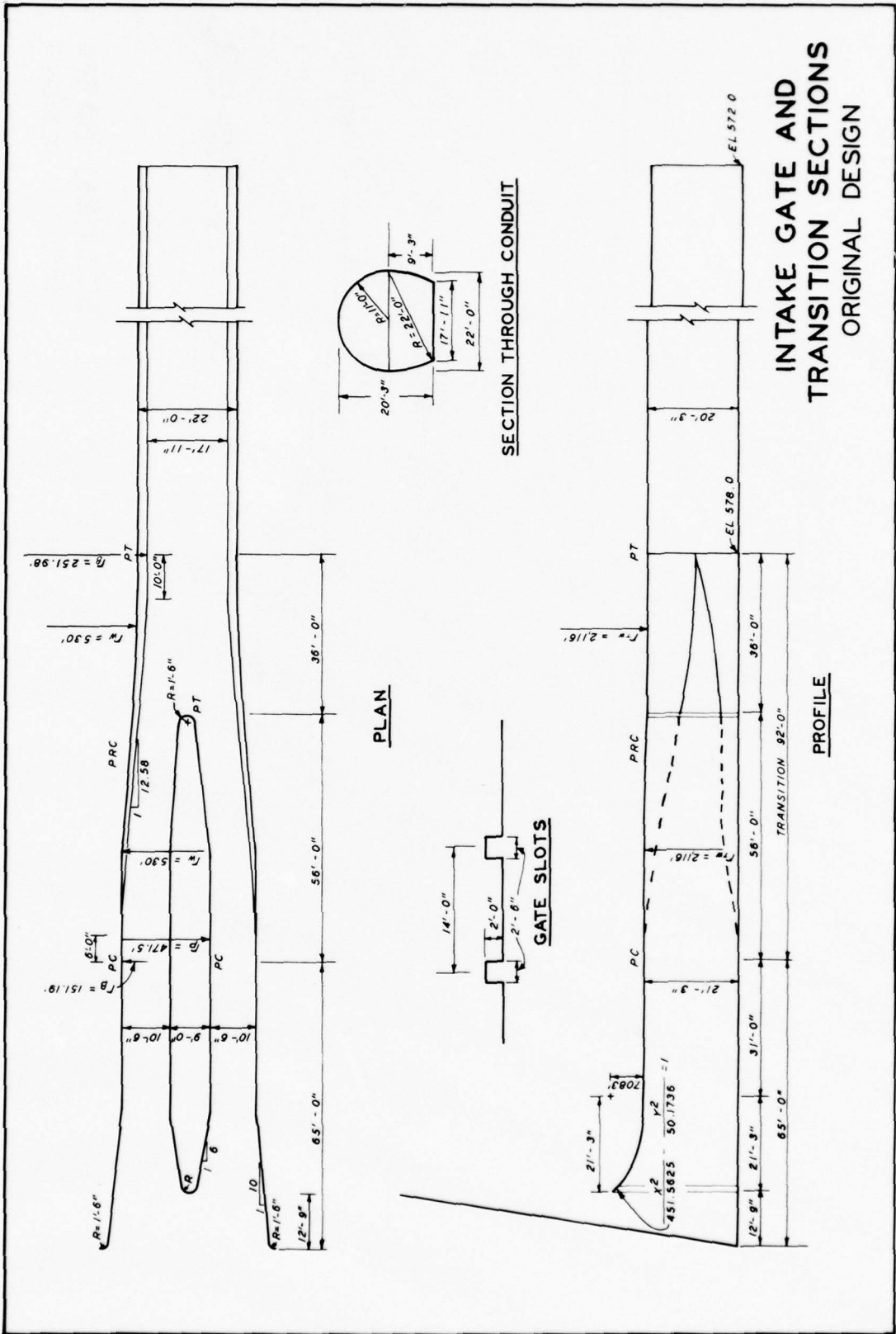
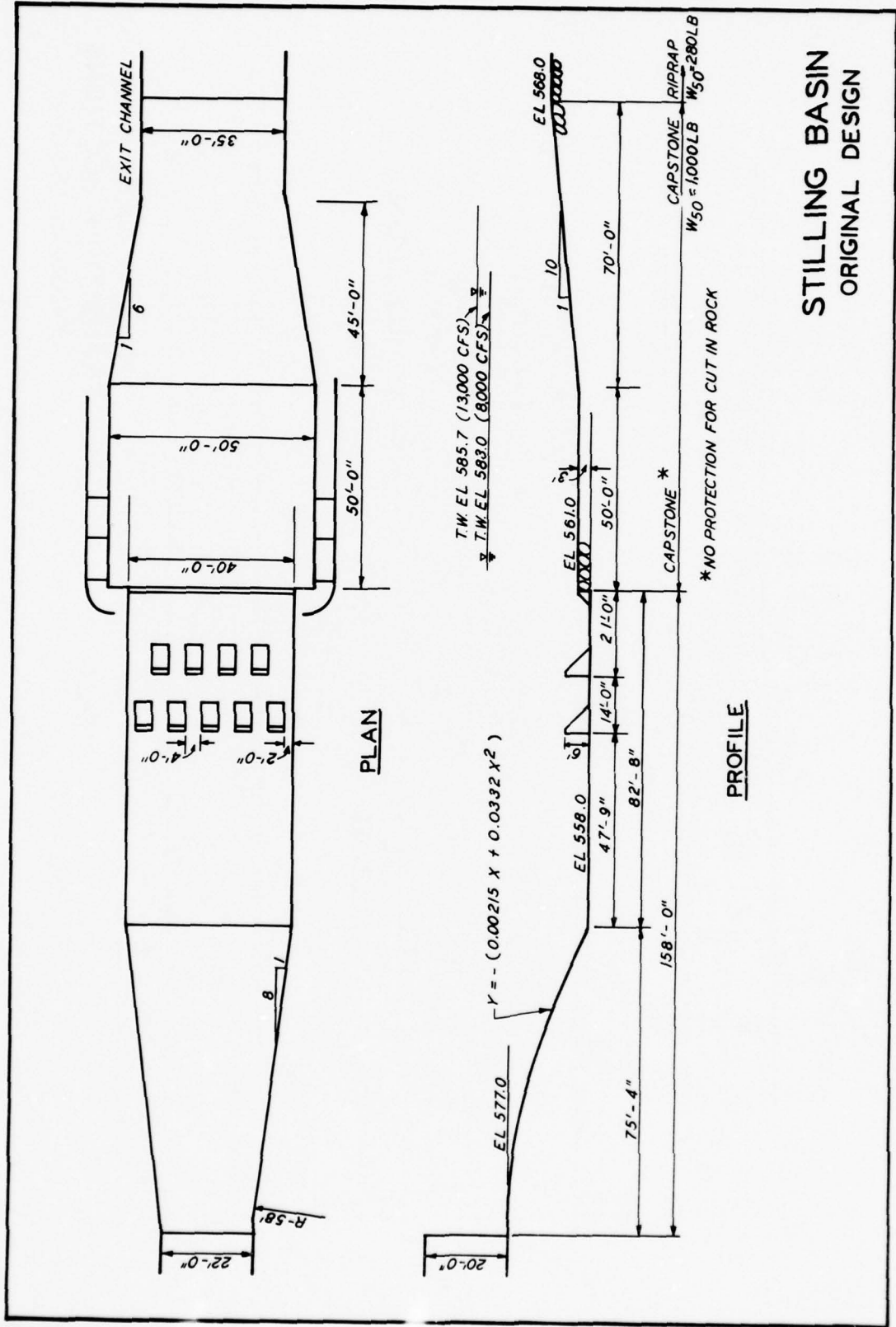
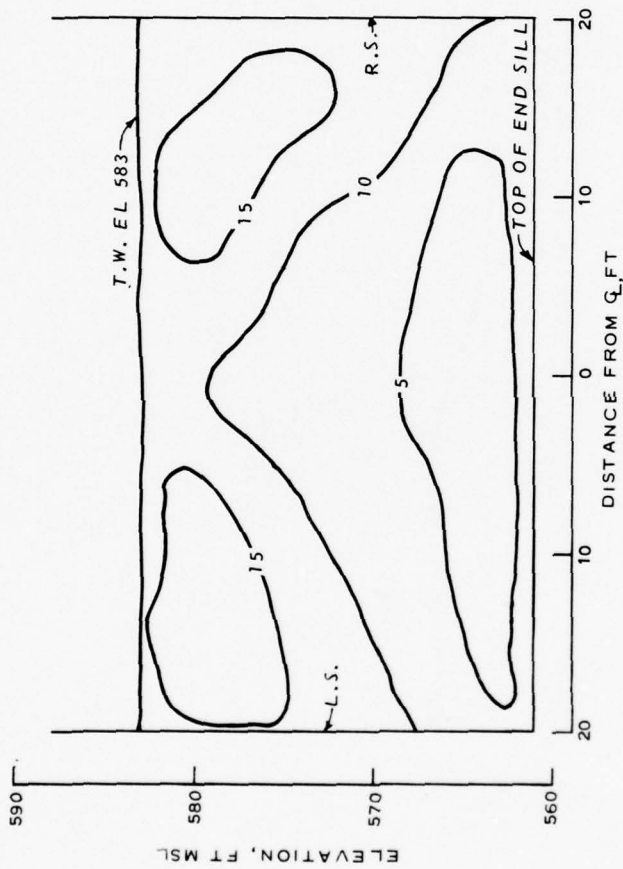

PLATE 2





**STILLING BASIN
ORIGINAL DESIGN**



TEST CONDITIONS

DISCHARGE 8000 CFS
 POOL EL 709 FT
 TAILWATER EL 583 FT

NOTE: VELOCITIES ARE IN PROTOTYPE
 FEET PER SECOND

ISOVELS AT END SILL
 ORIGINAL DESIGN
 22-FT - WIDE CONDUIT

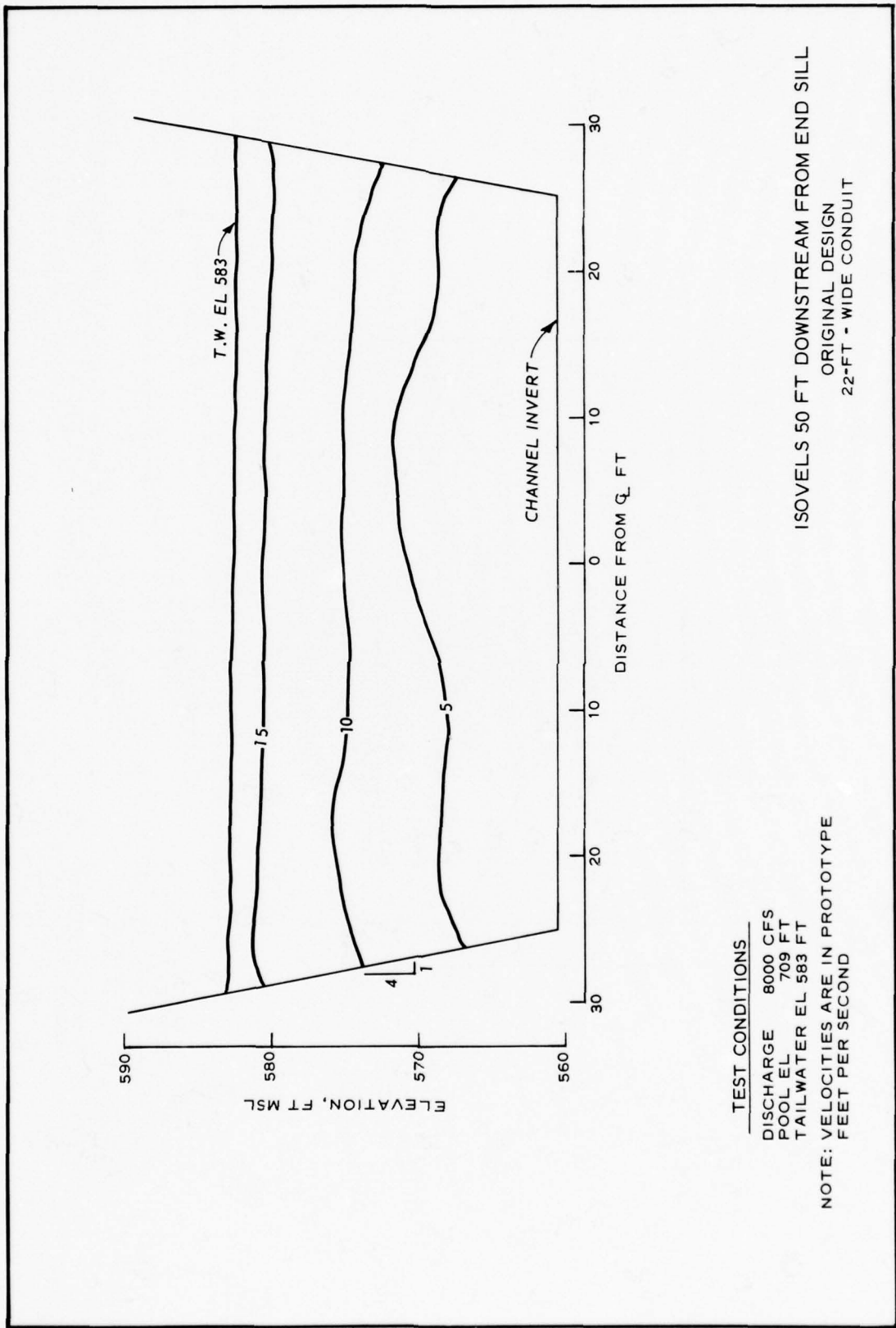

TEST CONDITIONS
 DISCHARGE 8000 CFS
 POOL EL 709 FT
 TAILWATER EL 583 FT
 NOTE: VELOCITIES ARE IN PROTOTYPE
 FEET PER SECOND

ISOVELS 50 FT DOWNSTREAM FROM END SILL
 ORIGINAL DESIGN
 22-FT - WIDE CONDUIT

PLATE 6

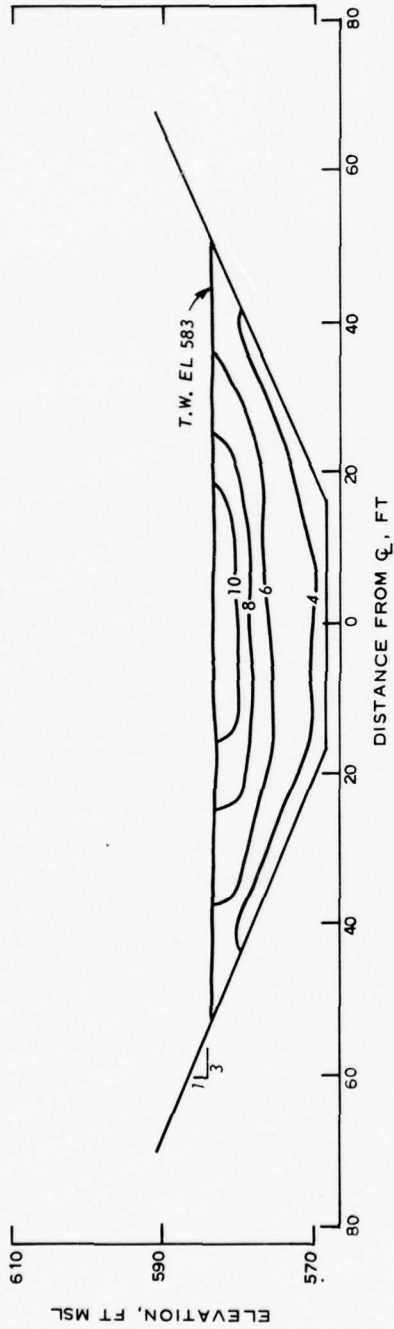

TEST CONDITIONS

DISCHARGE 8000 CFS
 POOL EL 709 FT
 TAILWATER EL 583 FT
 FEET PER SECOND

NOTE: VELOCITIES ARE IN PROTOTYPE

ISOVELS 120 FT DOWNSTREAM FROM END SILL
 ORIGINAL DESIGN
 22-FT - WIDE CONDUIT

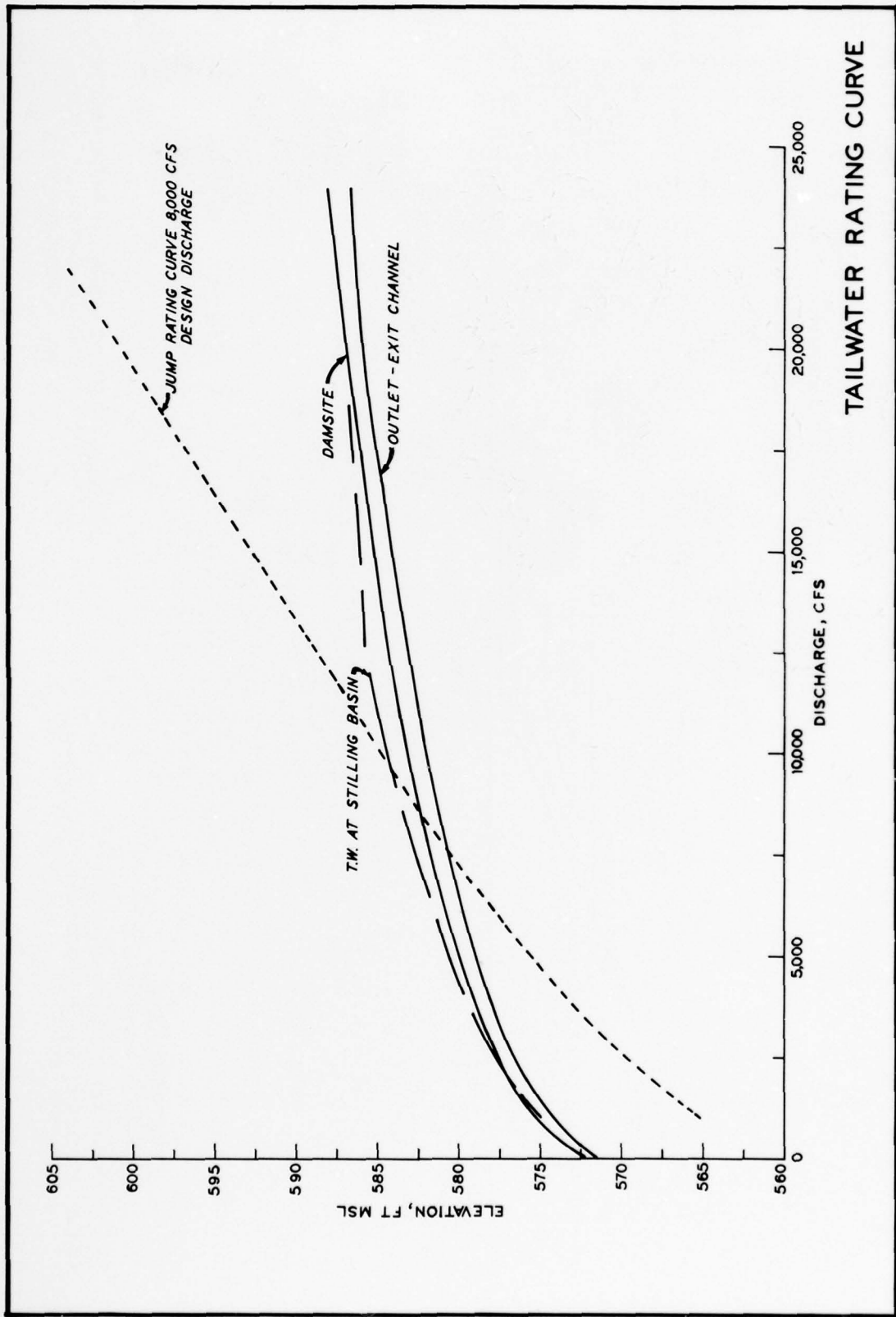
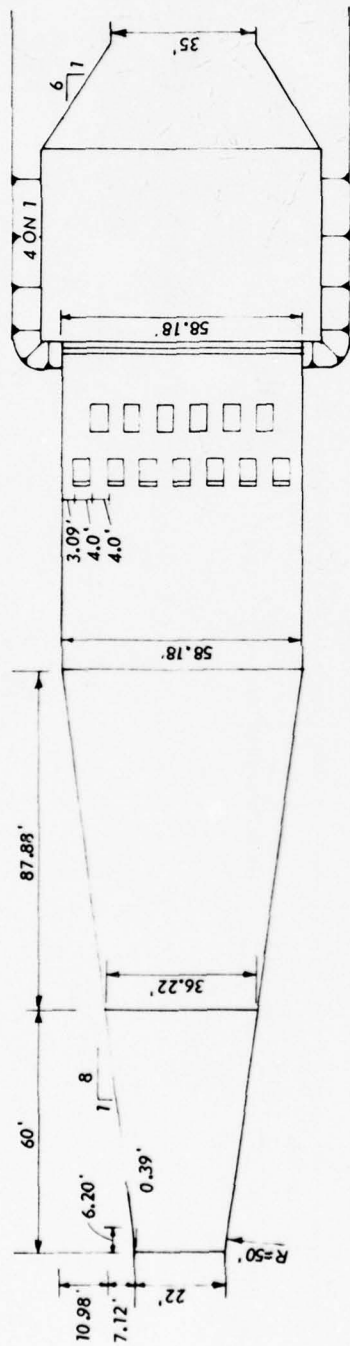
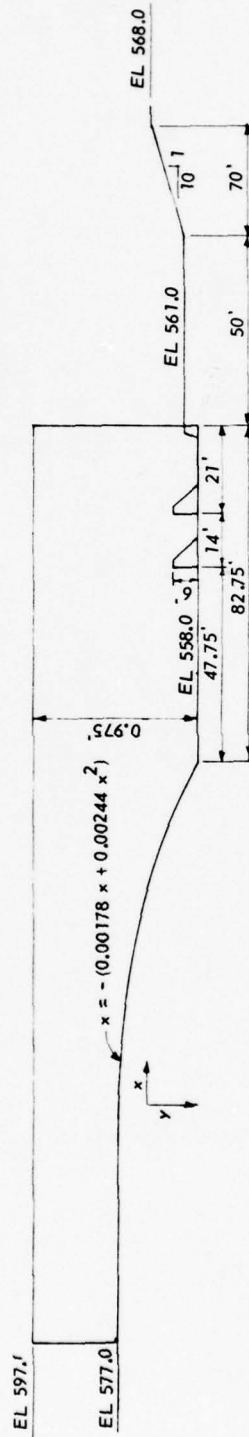

PLATE 8



PLAN



ELEVATION

TYPE 2 TRAJECTORY
22-FT - WIDE CONDUIT

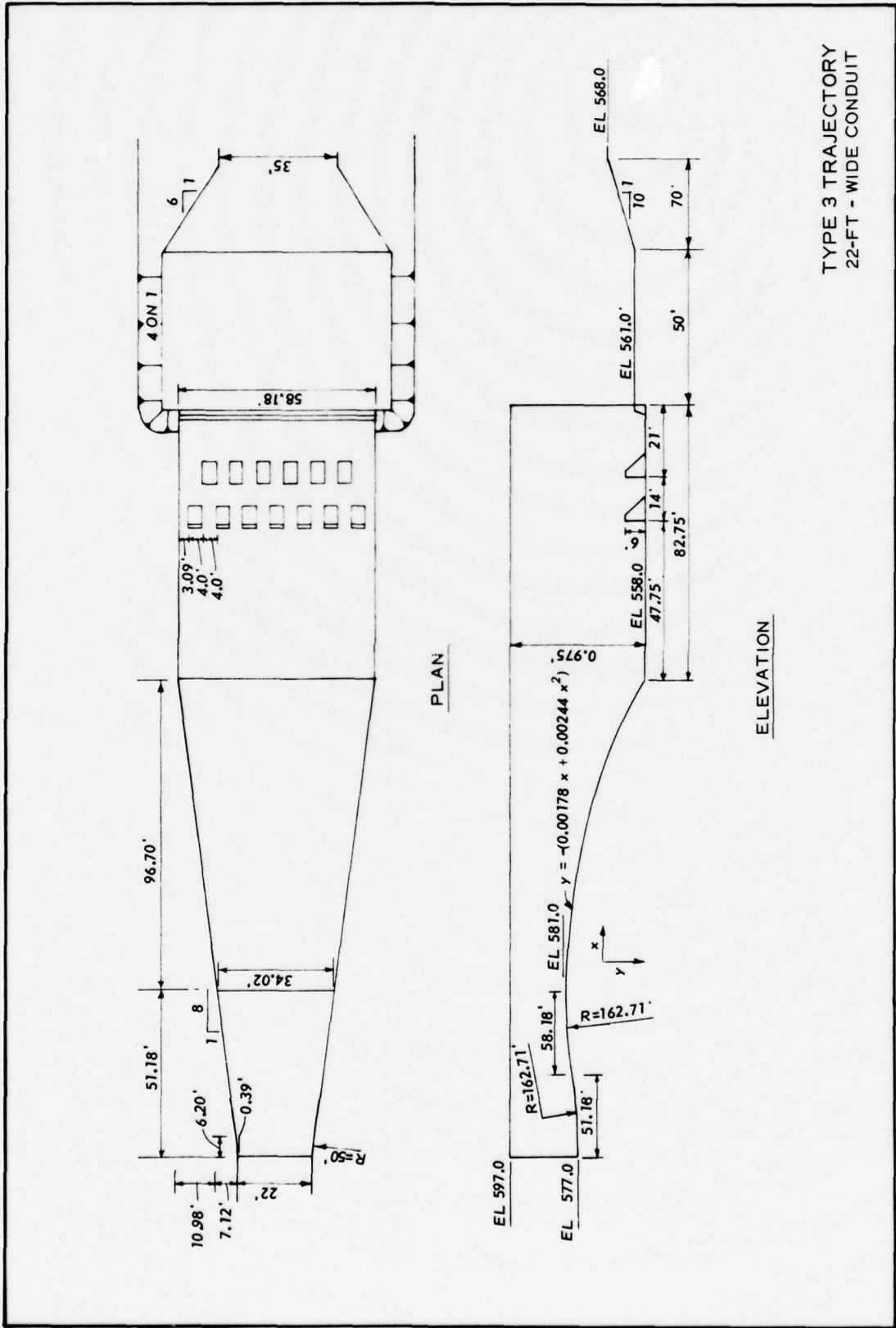

TYPE 3 TRAJECTORY
22-FT - WIDE CONDUIT

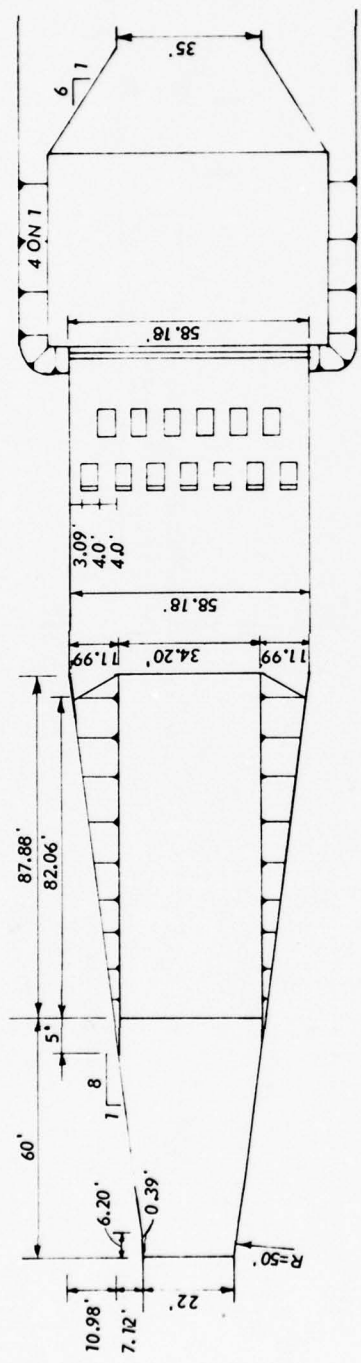

PLAN

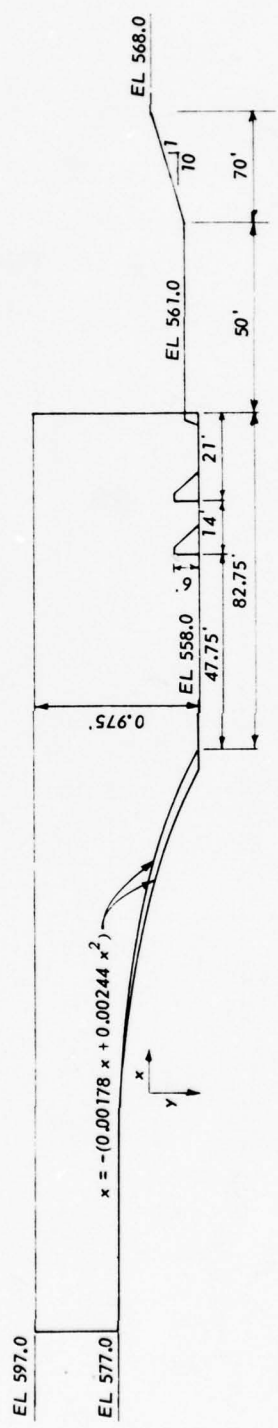

ELEVATION

TYPE 4 TRAJECTORY
22-FT - WIDE CONDUIT

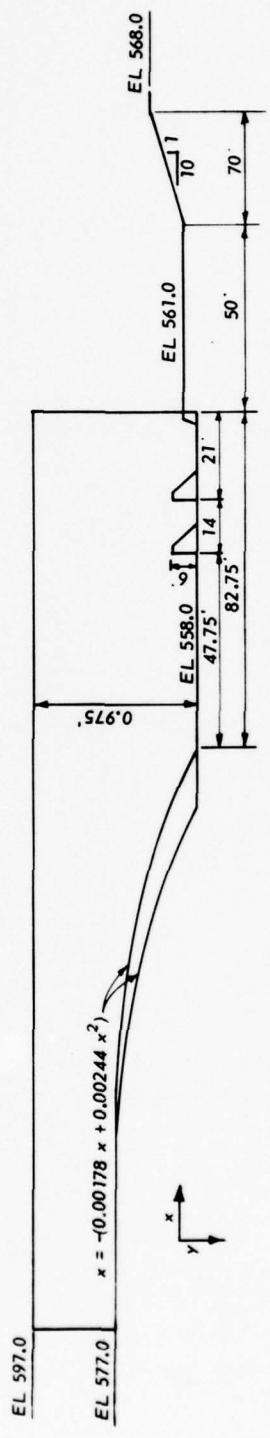
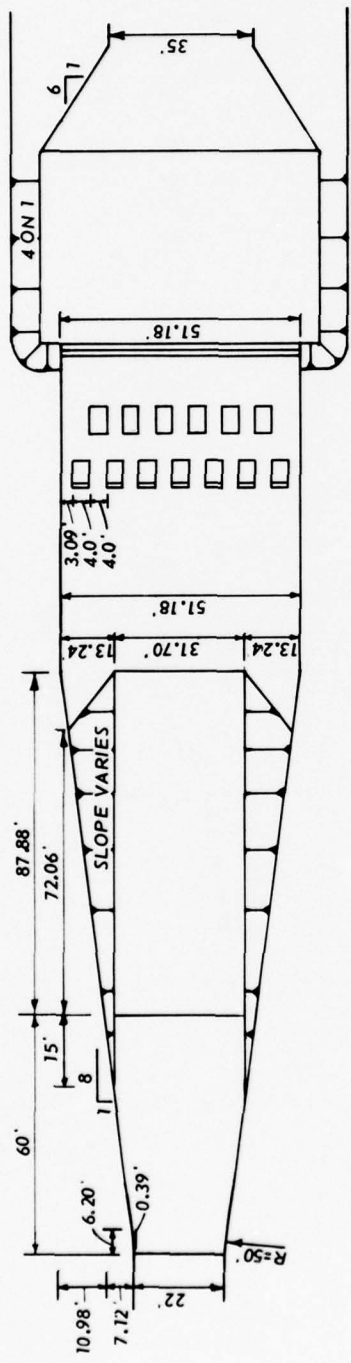

TYPE 5 TRAJECTORY
22-FT - WIDE CONDUIT

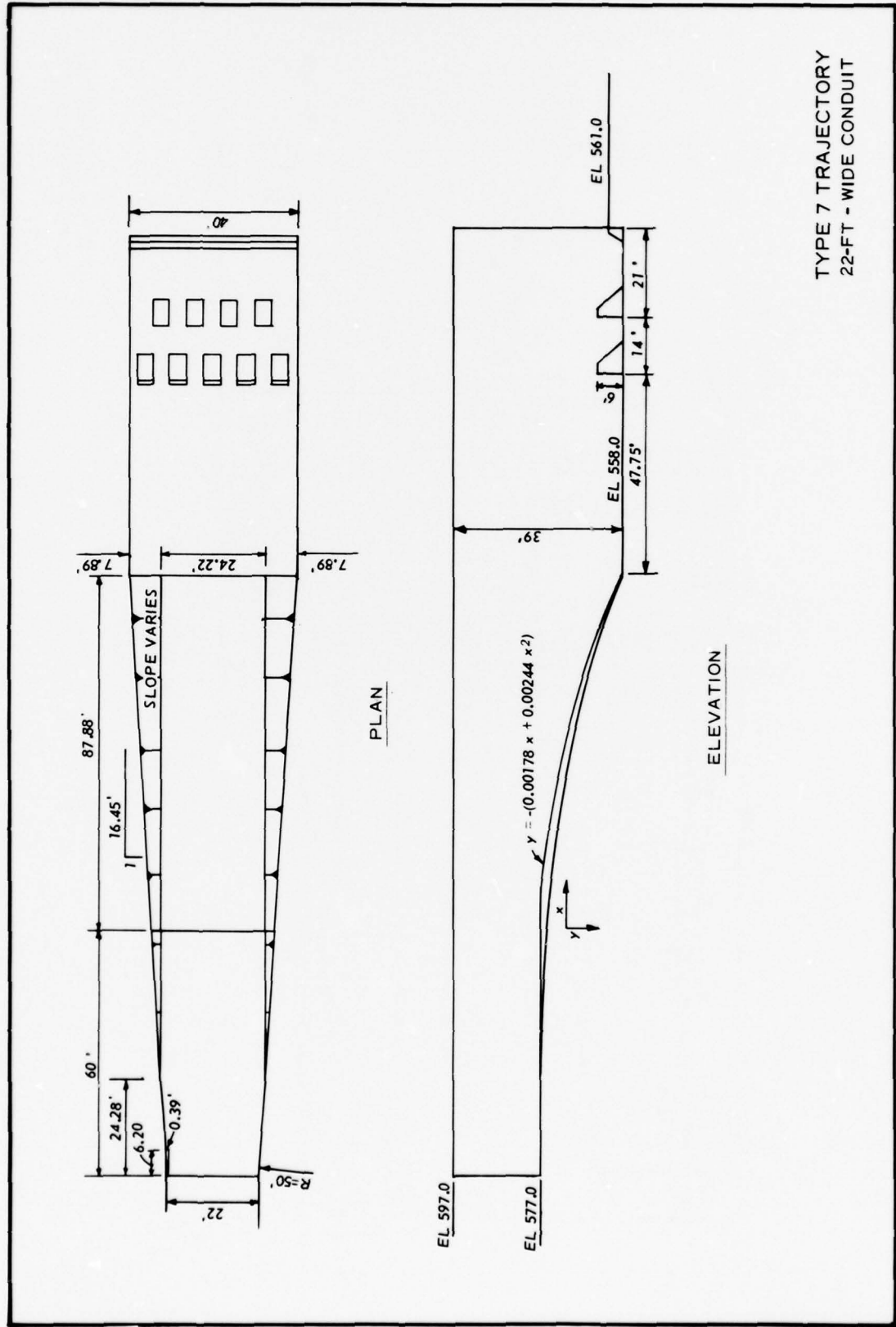

TYPE 7 TRAJECTORY
22-FT - WIDE CONDUIT

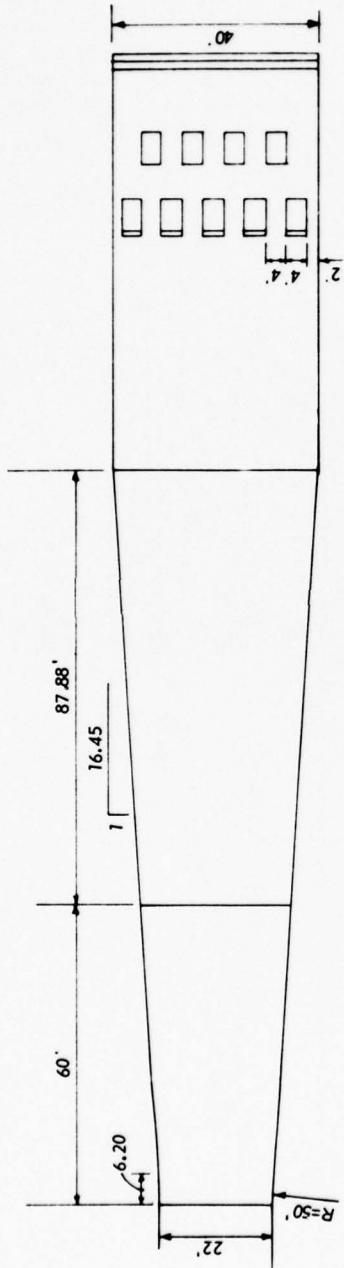

PLAN

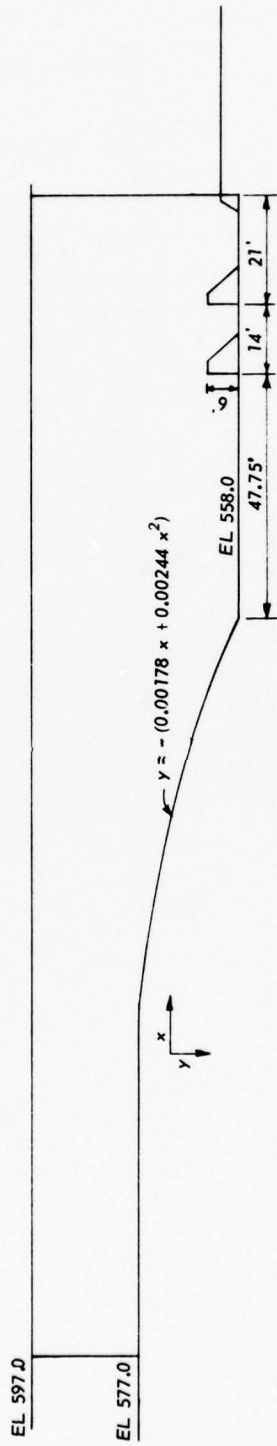

ELEVATION

TYPE 8 TRAJECTORY
22-FT - WIDE CONDUIT

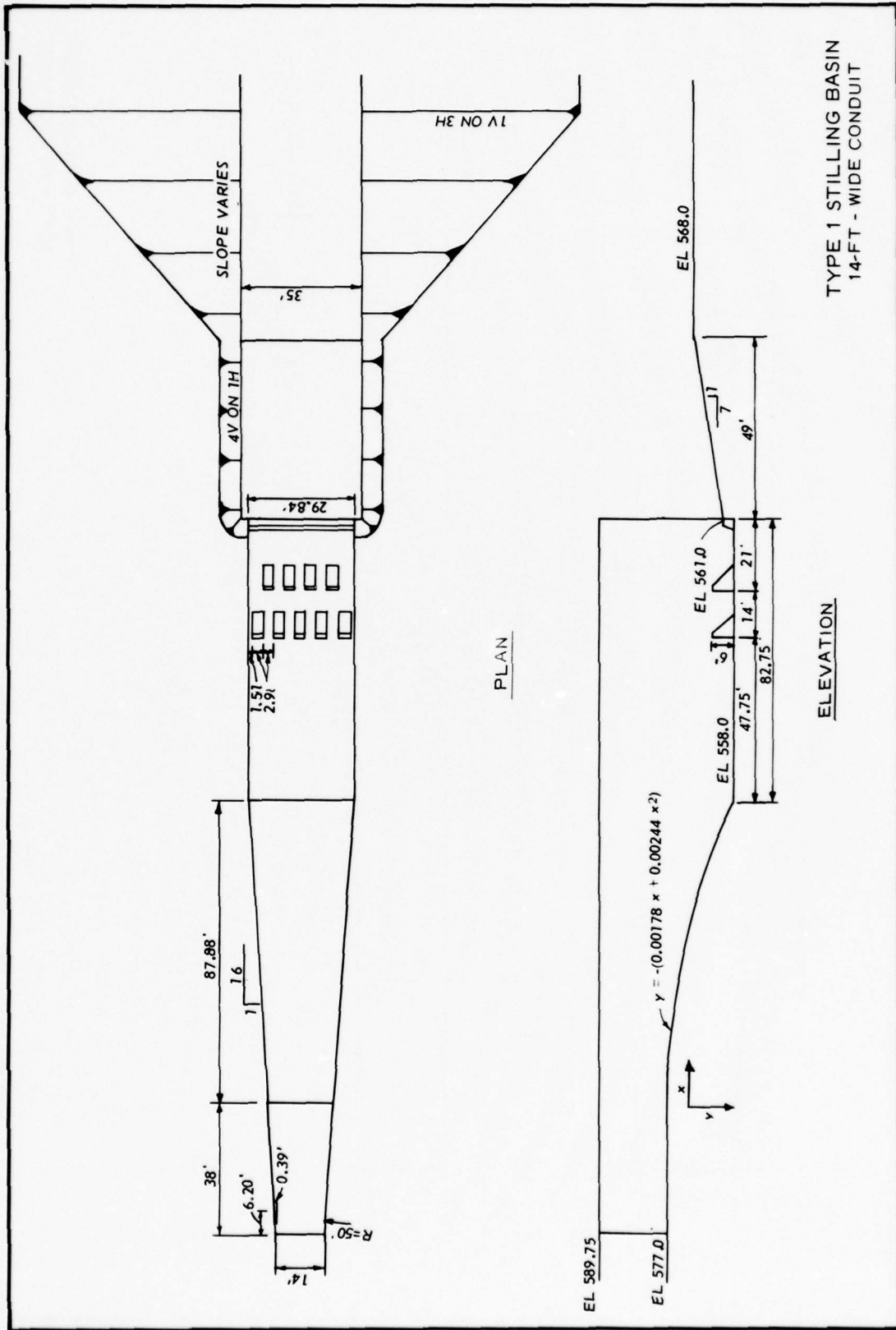

PLAN

ELEVATION

TYPE 1 STILLING BASIN
14-FT - WIDE CONDUIT

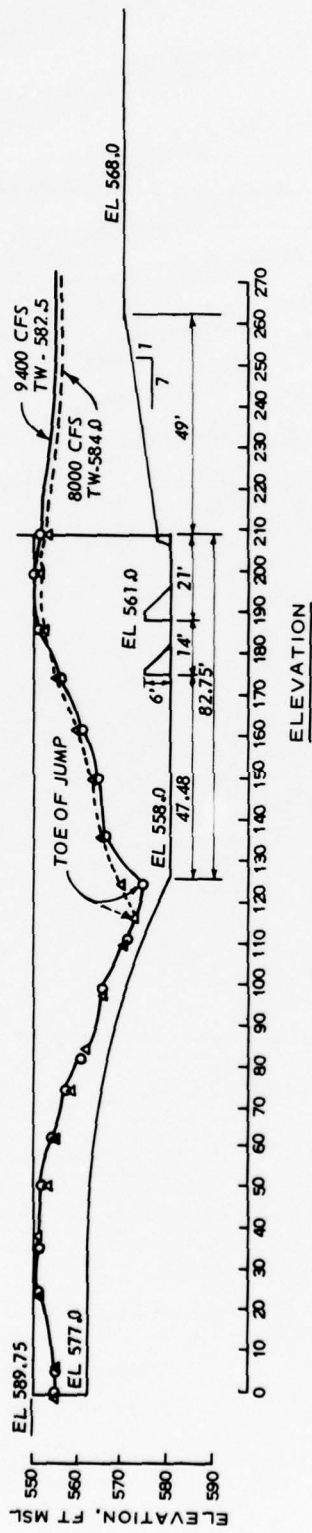

LEGEND
 —○— 9400 CFS
 - - - - - 8000 CFS

TYPE 1 STILLING BASIN
 14-FT - WIDE CONDUIT
 WATER - SURFACE PROFILES

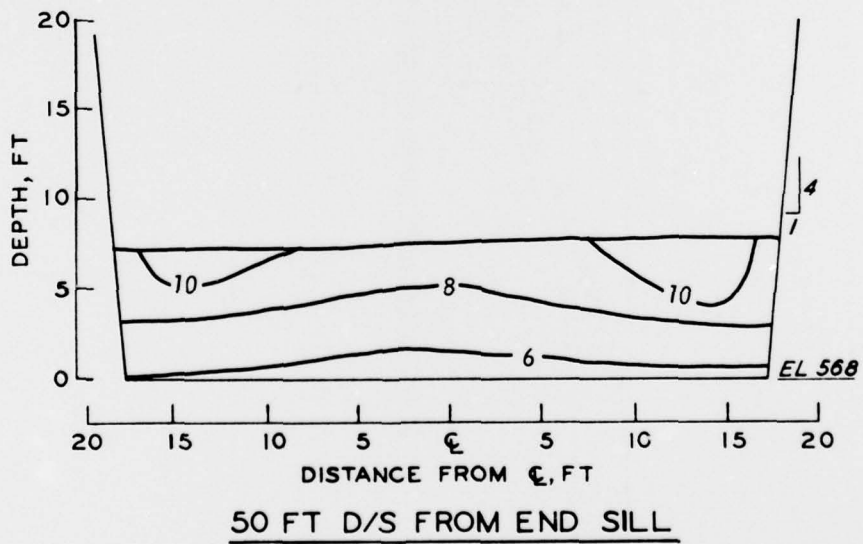
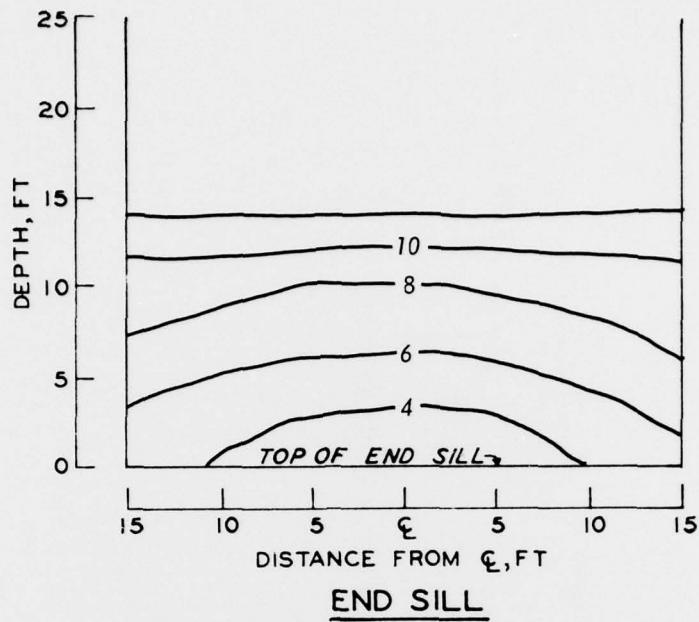

TYPE 1 STILLING BASIN
14-FT-WIDE CONDUIT
ISOVELS
DISCHARGE 2000 CFS
TAILWATER EL 577.0 FT
POOL EL 675.0 FT

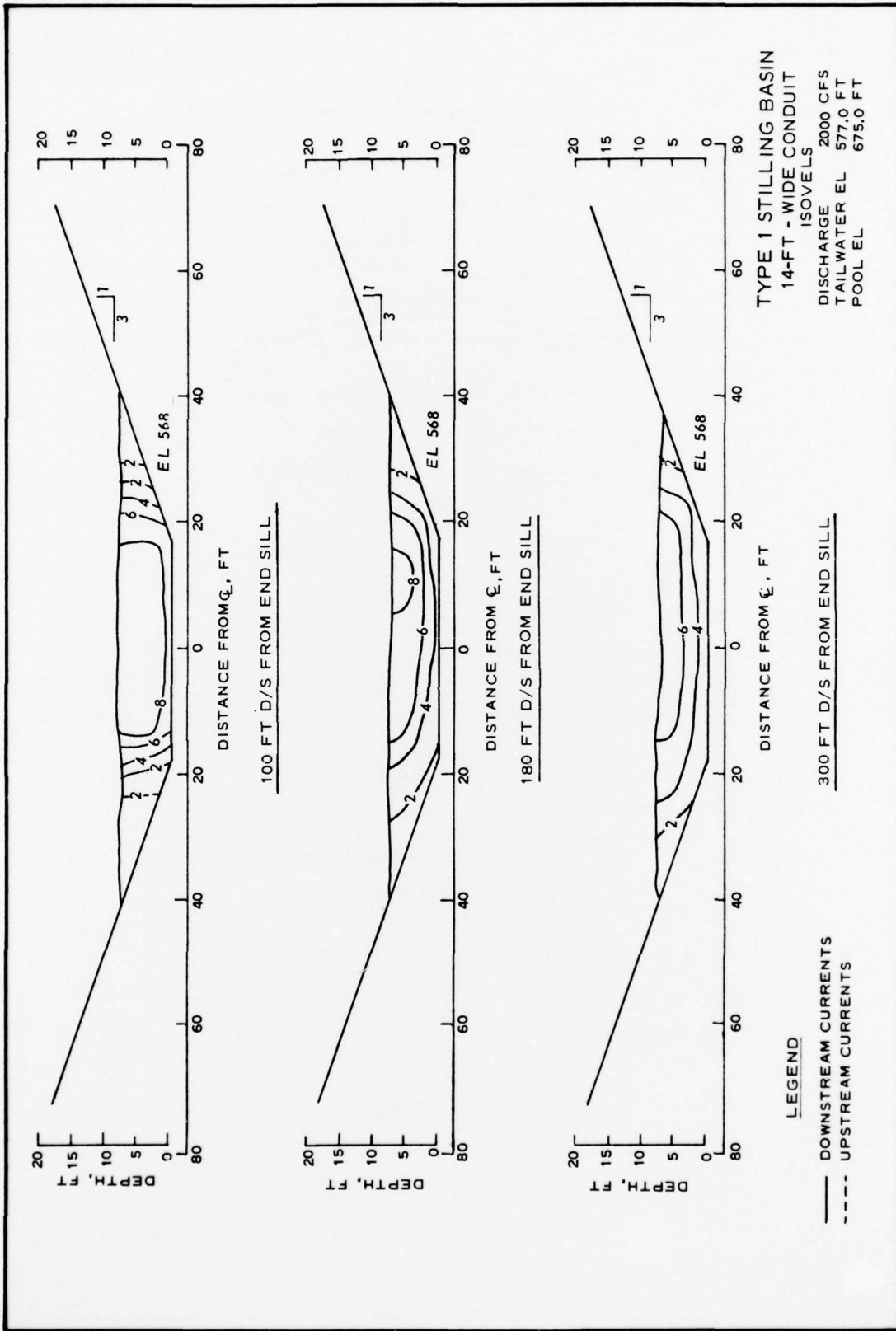

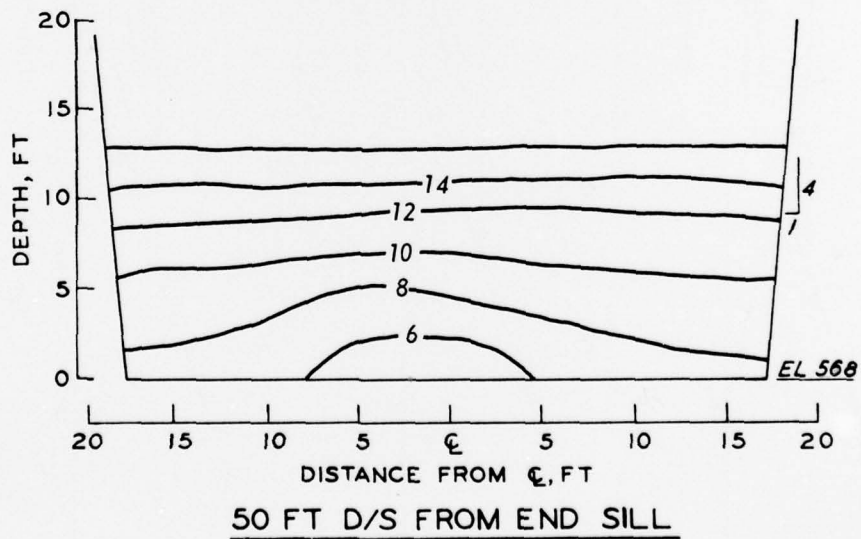
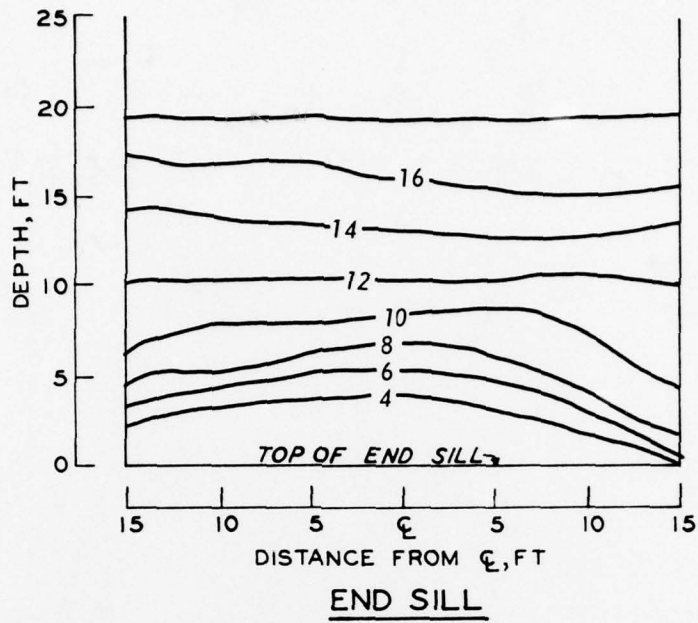

TYPE 1 STILLING BASIN
14-FT-WIDE CONDUIT

ISOVELS
DISCHARGE 5000 CFS
TAILWATER EL 580.5 FT
POOL EL 675.0 FT

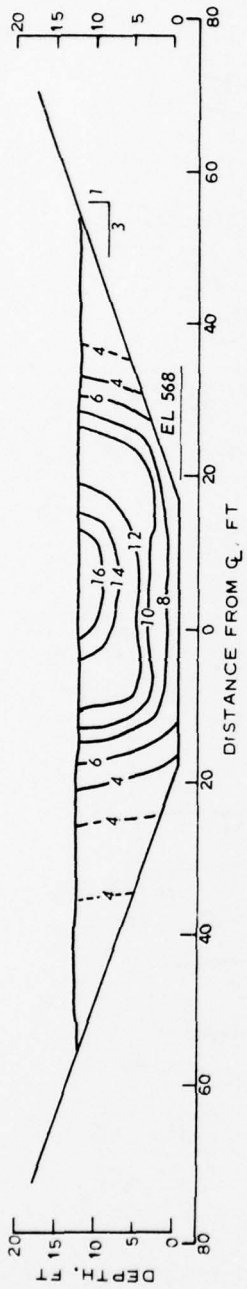

100 FT D/S FROM END SILL

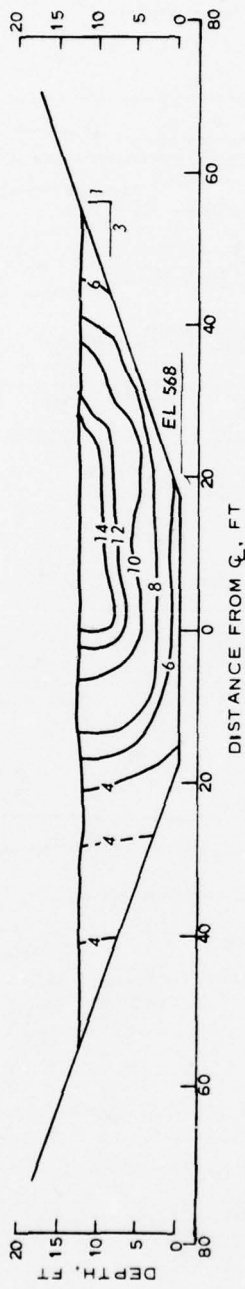

180 FT D/S FROM END SILL

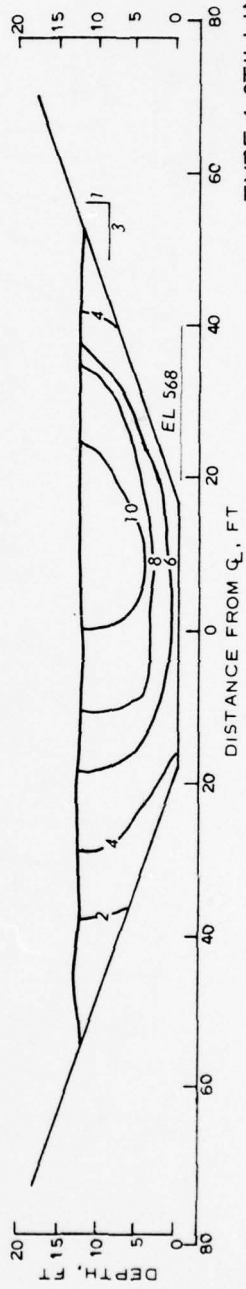

300 FT D/S FROM END SILL

LEGEND
 ——— DOWNSTREAM CURRENTS
 - - - UPSTREAM CURRENTS

TYPE 1 STILLING BASIN
14-FT - WIDE CONDUIT
 ISOVELS
 DISCHARGE 5000 CFS
 TAILWATER EL 580.5 FT
 POOL EL 675.0 FT

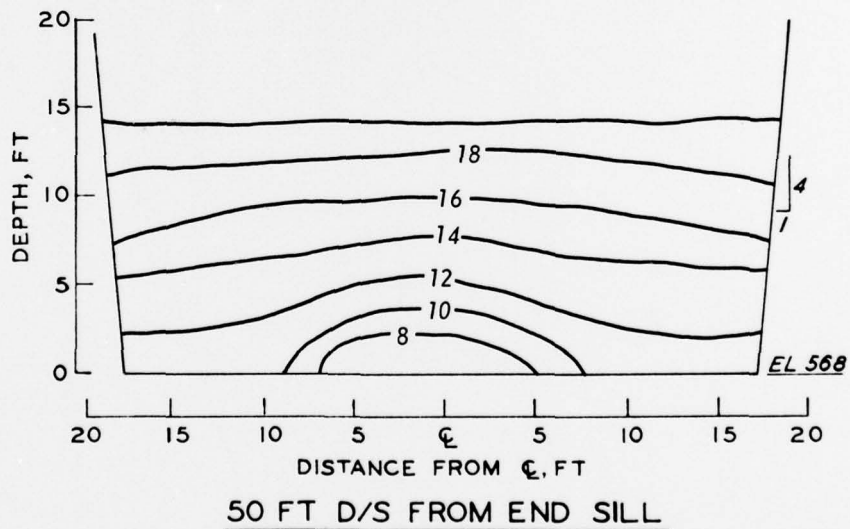
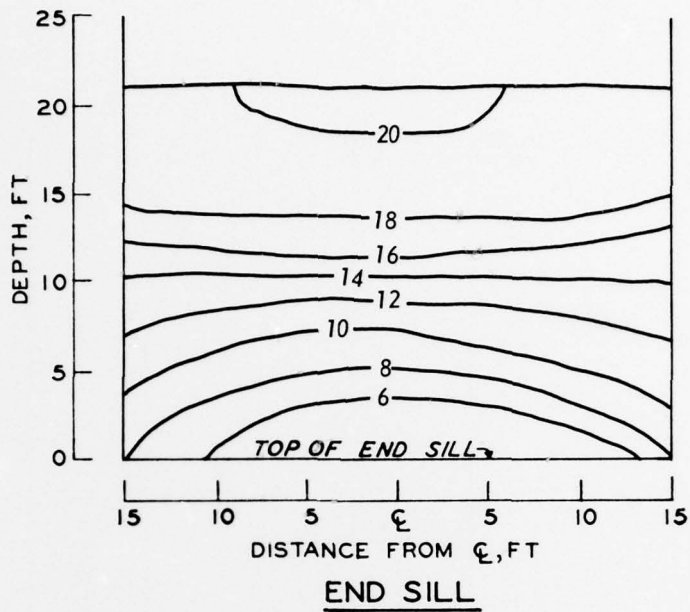

**TYPE 1 STILLING BASIN
14-FT-WIDE CONDUIT
ISOVELS**

DISCHARGE 8000 CFS
TAILWATER EL 582.5 FT
POOL EL 675.0 FT

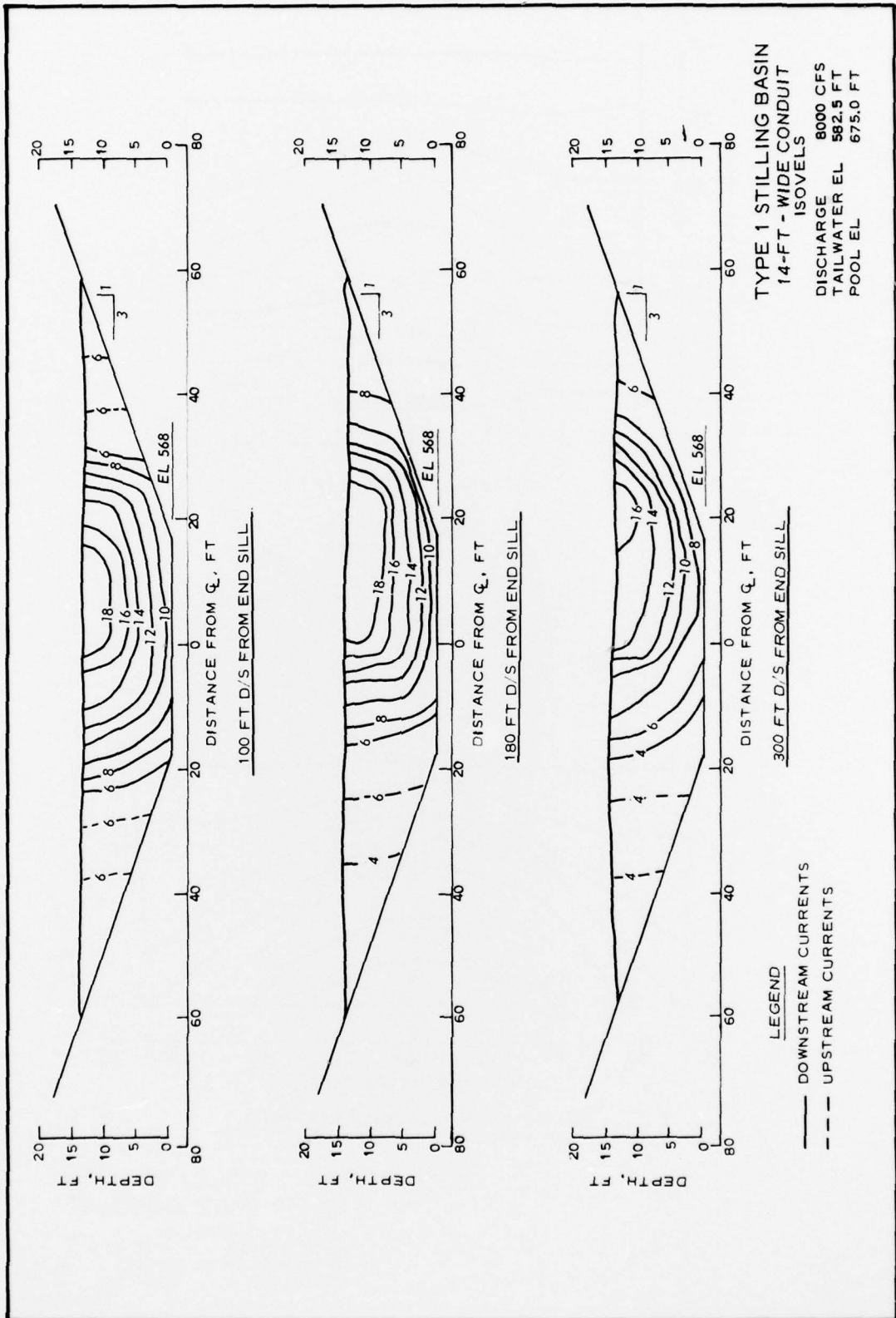

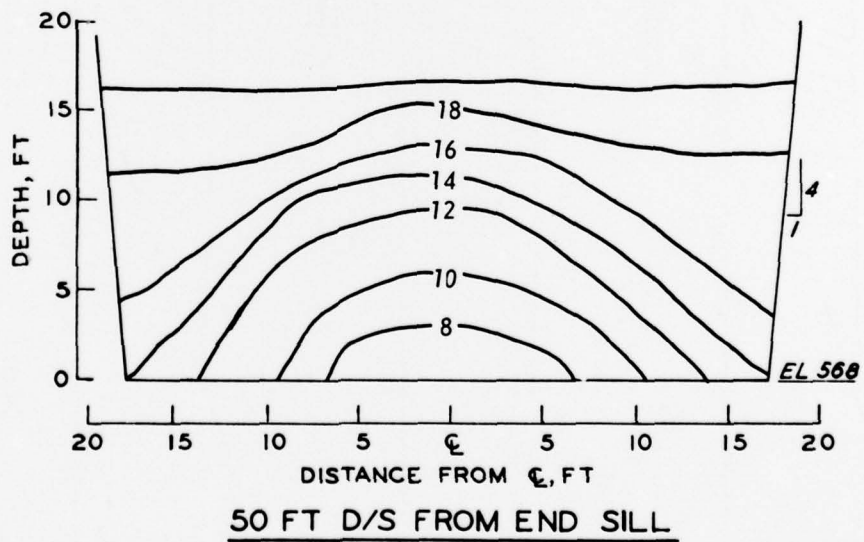
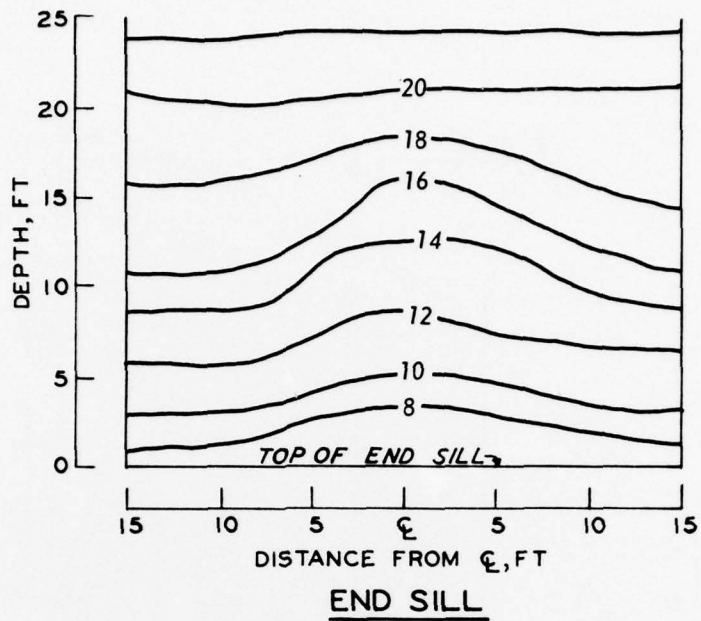

TYPE 1 STILLING BASIN
14-FT-WIDE CONDUIT
ISOVELS
DISCHARGE 9400 CFS
TAILWATER EL 584.0 FT
POOL EL 709.0 FT

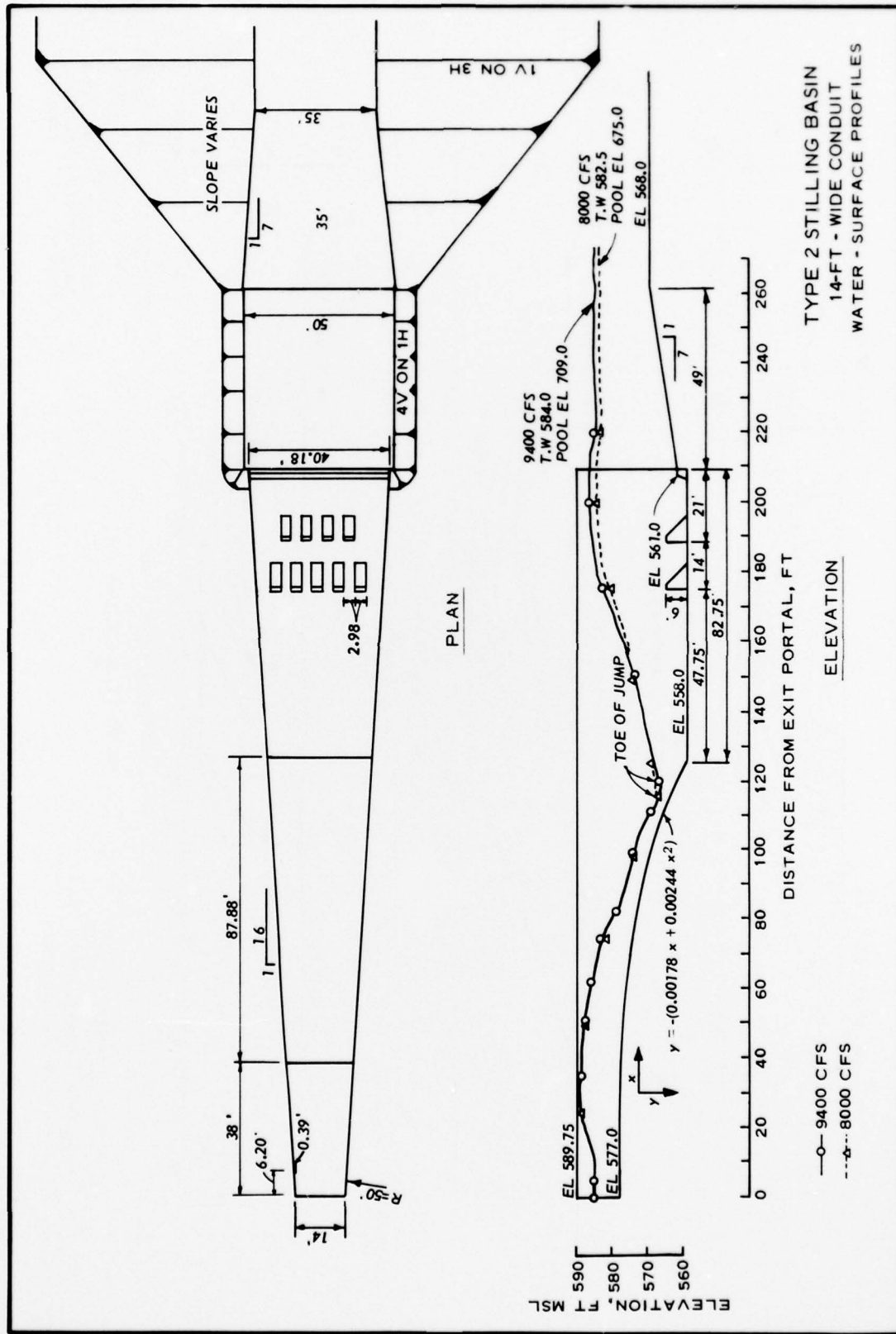

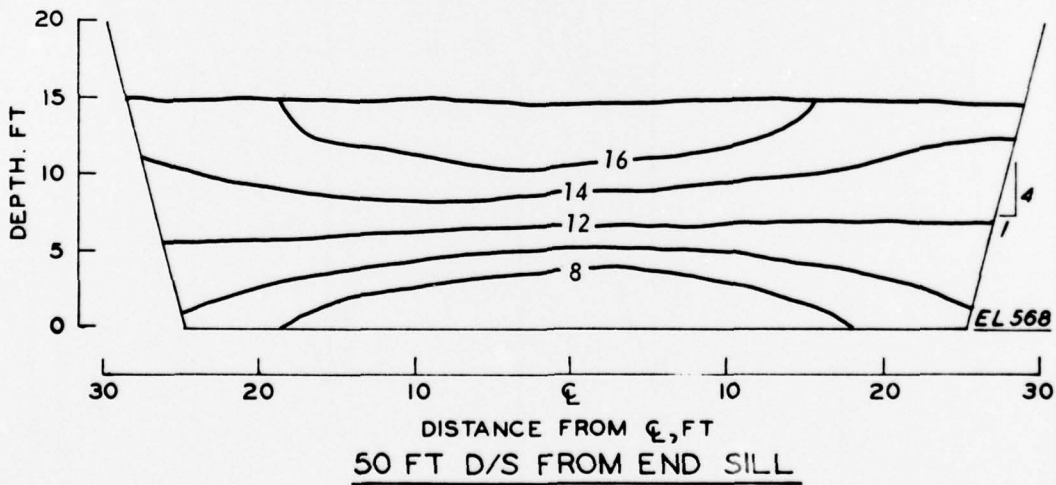
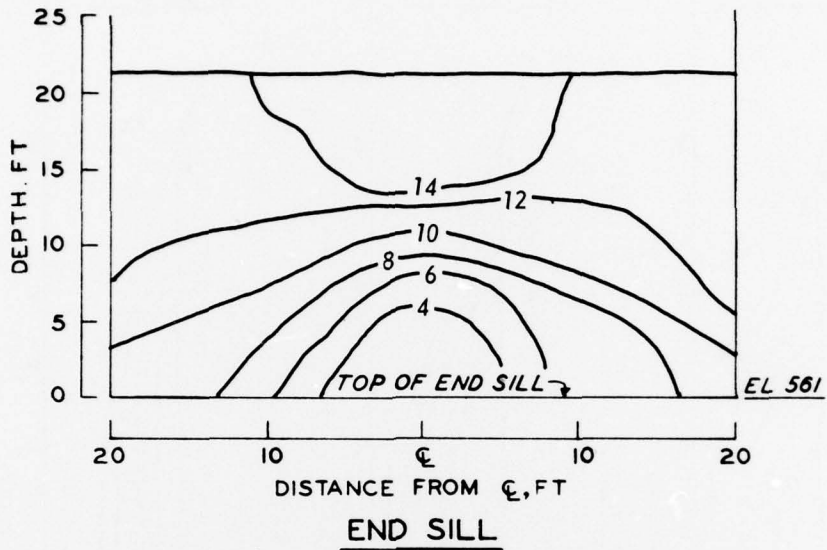

TYPE 2 STILLING BASIN
14-FT-WIDE CONDUIT
ISOVELS

DISCHARGE 8000 CFS
TAILWATER EL 582.5 FT
POOL EL 675.0 FT

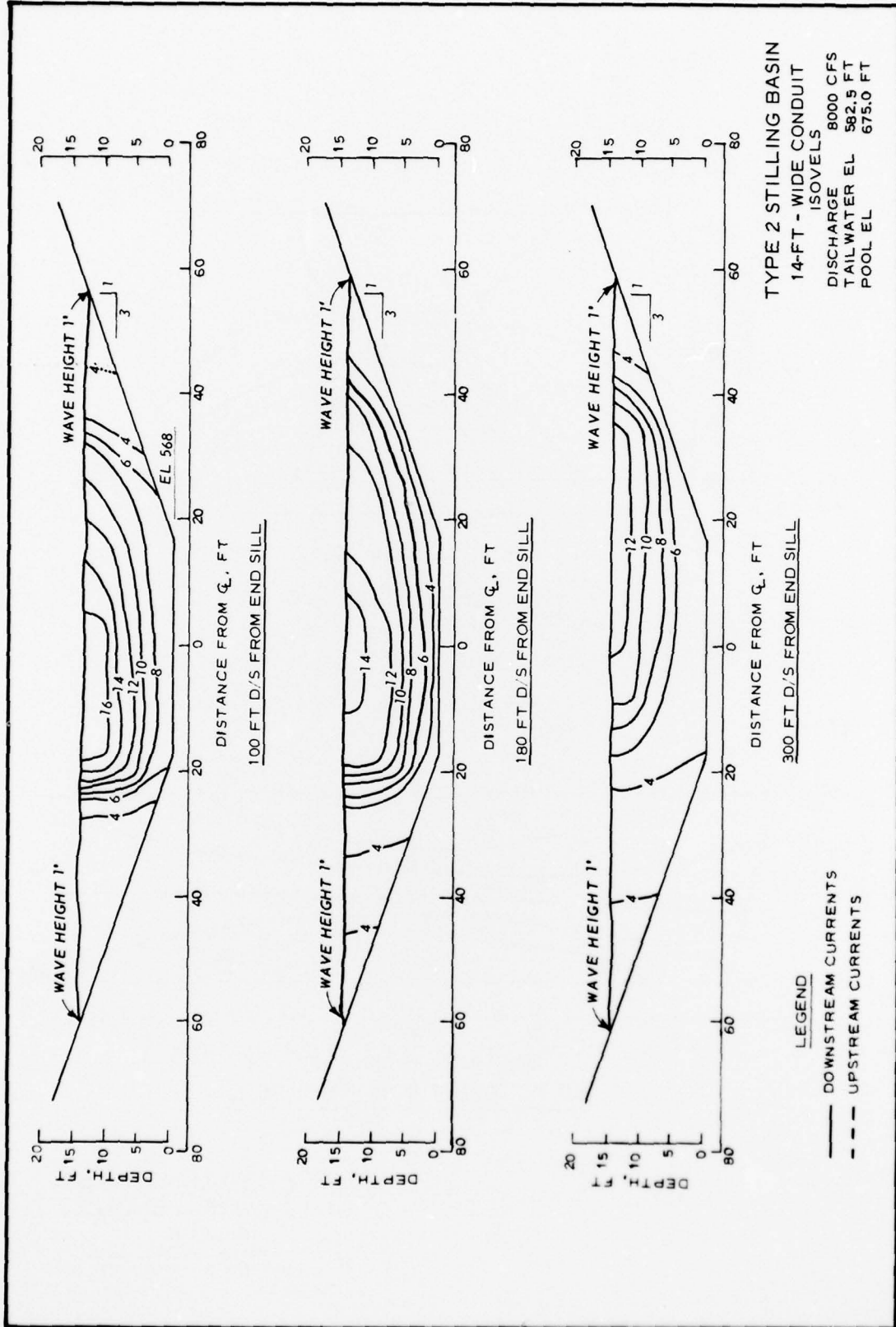
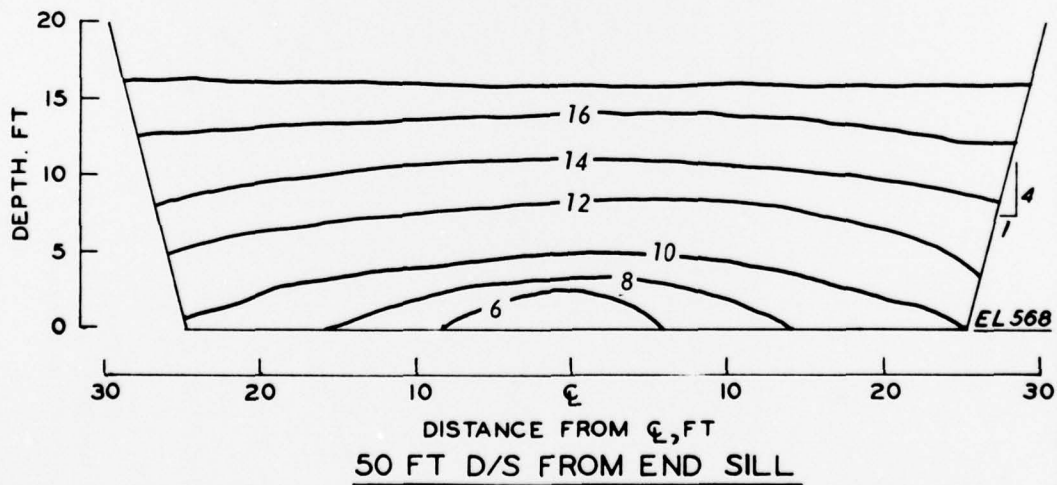
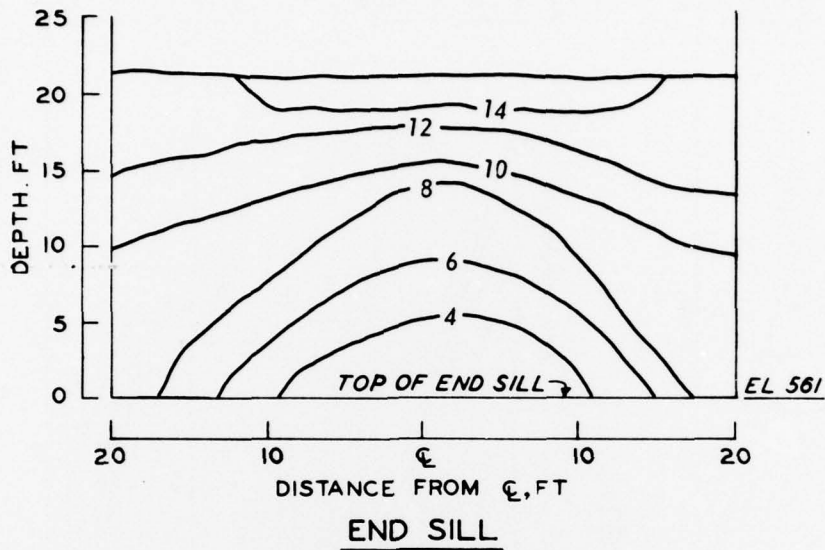

PLATE 28



TYPE 2 STILLING BASIN

14-FT-WIDE CONDUIT

ISOVELS

DISCHARGE 9400 CFS
 TAILWATER EL 584.0 FT
 POOL EL 709.0 FT

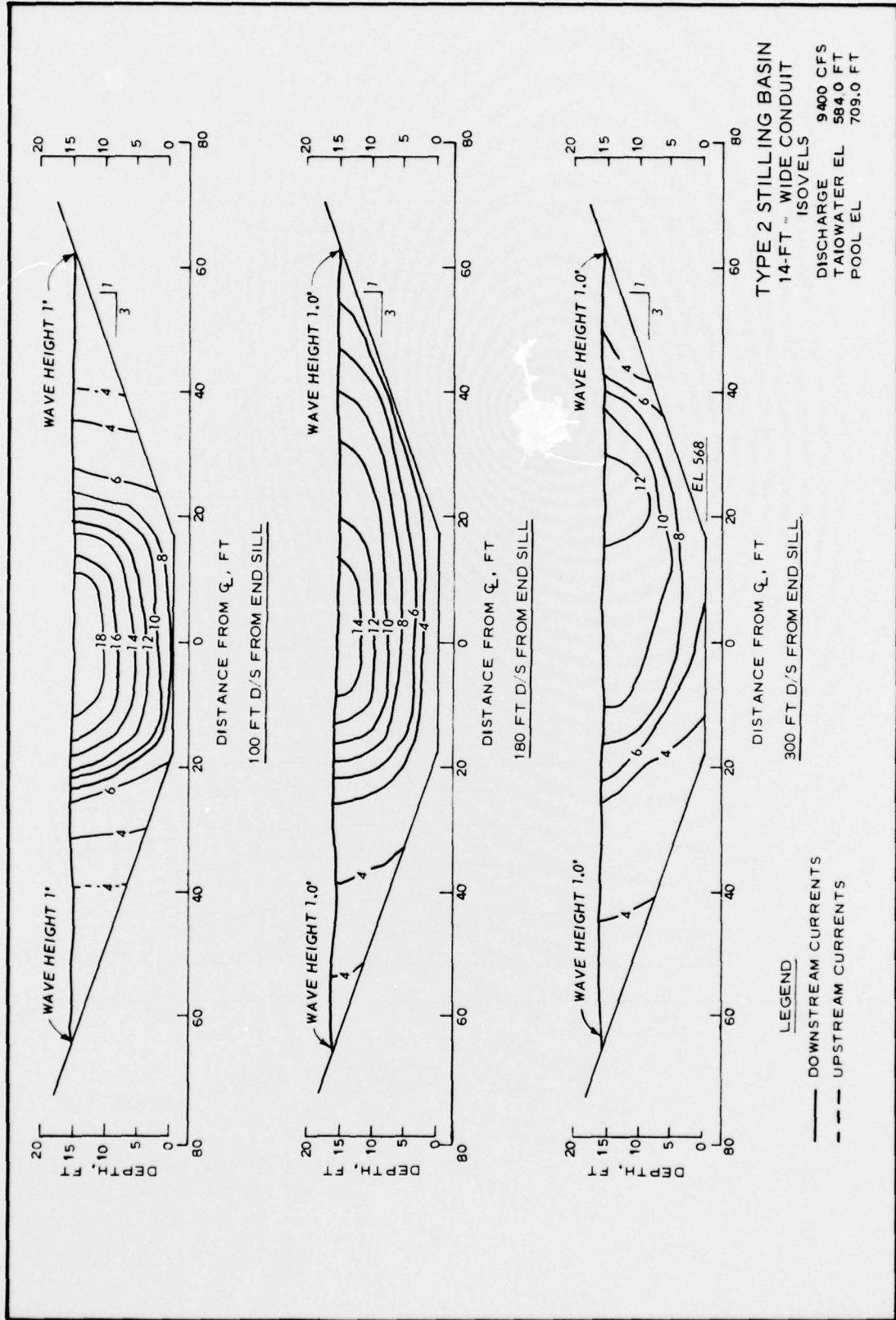

PLATE 30

In accordance with letter from DAEN-RDC, DAEN-ASI dated 22 July 1977, Subject: Facsimile Catalog Cards for Laboratory Technical Publications, a facsimile catalog card in Library of Congress MARC format is reproduced below.

Fletcher, Bobby P

Outlet structure for Meramec Lake, Meramec River, Missouri; hydraulic model investigation / by Bobby P. Fletcher. Vicksburg, Miss. : U. S. Waterways Experiment Station ; Springfield, Va. : available from National Technical Information Service, 1978.

19, [10] p., 30 leaves of plates : ill. ; 27 cm. (Technical report - U. S. Army Engineer Waterways Experiment Station ; H-78-15)

Prepared for U. S. Army Engineer District, St. Louis, St. Louis, Missouri.

1. Hydraulic models. 2. Intake structures. 3. Meramec Lake. 4. Outlet works. I. United States. Army. Corps of Engineers. St. Louis District. II. Series: United States. Waterways Experiment Station, Vicksburg, Miss. Technical report ; H-78-15. TA7.W34 no.H-78-15