

AD-A062 251

OREGON STATE UNIV CORVALLIS DEPT OF AGRICULTURAL CHE--ETC F/G 7/3
METABOLISM OF HYDRAZINE.(U)
SEP 78 F N DOST, D L SPRINGER

UNCLASSIFIED

[OF]

AD
A062251



AMRL-TR-78-47

F33615-77-C-0500

NL



END
DATE
FILMED
3 --79
DDC

ADA062251

AMRL-TR-78-47

LEVEL

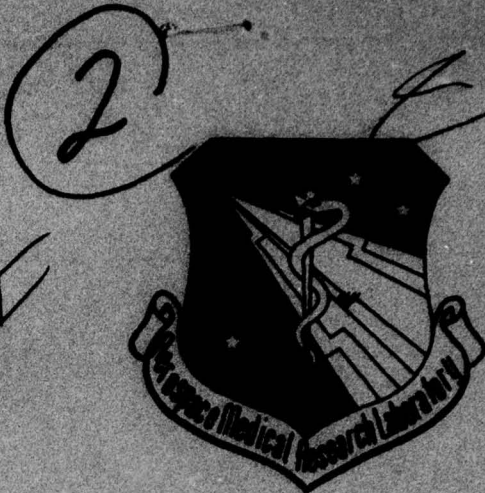

METABOLISM OF HYDRAZINE

F. N. DOST

D. L. SPRINGER

OREGON STATE UNIVERSITY

DEPARTMENT OF AGRICULTURAL CHEMISTRY

CORVALLIS, OREGON 97331

SEPTEMBER 1978

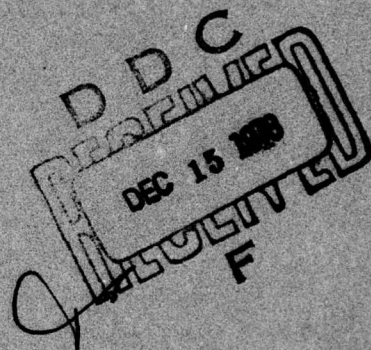

DDC FILE COPY

Approved for public release; distribution unlimited.

AEROSPACE MEDICAL RESEARCH LABORATORY
AEROSPACE MEDICAL DIVISION
AIR FORCE SYSTEMS COMMAND
WRIGHT-PATTERSON AIR FORCE BASE, OHIO 45433

78 11 28 019

NOTICES

When US Government drawings, specifications, or other data are used for any purpose other than a definitely related Government procurement operation, the Government thereby incurs no responsibility nor any obligation whatsoever, and the fact that the Government may have formulated, furnished, or in any way supplied the said drawings, specifications, or other data, is not to be regarded by implication or otherwise, as in any manner licensing the holder or any other person or corporation, or conveying any rights or permission to manufacture, use, or sell any patented invention that may in any way be related thereto.

Please do not request copies of this report from Aerospace Medical Research Laboratory. Additional copies may be purchased from:

National Technical Information Service
5285 Port Royal Road
Springfield, Virginia 22161

Federal Government agencies and their contractors registered with Defense Documentation Center should direct requests for copies of this report to:

Defense Documentation Center
Cameron Station
Alexandria, Virginia 22314

TECHNICAL REVIEW AND APPROVAL

AMRL-TR-78-47

The experiments reported herein were conducted according to the "Guide for the Care and Use of Laboratory Animals," Institute of Laboratory Animal Resources, National Research Council.

This report has been reviewed by the Information Office (OI) and is releasable to the National Technical Information Service (NTIS). At NTIS, it will be available to the general public, including foreign nations.

This technical report has been reviewed and is approved for publication.

FOR THE COMMANDER

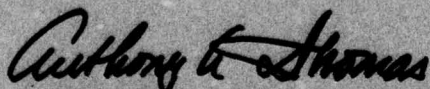

ANTHONY A. THOMAS, MD
Director
Toxic Hazards Division
Aerospace Medical Research Laboratory

19 REPORT DOCUMENTATION PAGE		READ INSTRUCTIONS BEFORE COMPLETING FORM	
1. REPORT NUMBER 18 AMRL TR-78-47	2. GOVT ACCESSION NO.	3. RECIPIENT'S CATALOG NUMBER Kept.	
4. TITLE (and Subtitle) 6 METABOLISM OF HYDRAZINE		5. TYPE OF REPORT & PERIOD COVERED 9 Annual 17 Jan 77-17 Jan 78	
7. AUTHOR(s) 19 F. N. Dost D. L. Springer		8. CONTRACT OR GRANT NUMBER(s) 15 F33615-77-C-0500 new	
9. PERFORMING ORGANIZATION NAME AND ADDRESS Dept of Agricultural Chemistry Oregon State Univ., Corvallis, OR 97331		10. PROGRAM ELEMENT, PROJECT, TASK AREA & WORK UNIT NUMBERS 16 61101F 2312-V1-116	
11. CONTROLLING OFFICE NAME AND ADDRESS Aerospace Medical Research Laboratory Aerospace Medical Division Air Force Systems Command Wright-Patterson AFB, Ohio 45433		12. REPORT DATE 11 September 1978	
14. MONITORING AGENCY NAME & ADDRESS (if different from Controlling Office) 12 22p.		13. NUMBER OF PAGES 22	
		15. SECURITY CLASS. (of this report) UNCLASSIFIED	
		15a. DECLASSIFICATION/DOWNGRADING SCHEDULE	
16. DISTRIBUTION STATEMENT (of this Report) Approved for public release; distribution unlimited			
17. DISTRIBUTION STATEMENT (of the abstract entered in Block 20, if different from Report)			
18. SUPPLEMENTARY NOTES			
19. KEY WORDS (Continue on reverse side if necessary and identify by block number) Nitrogen-15 Hydrazine metabolism Respiratory gases			
20. ABSTRACT (Continue on reverse side if necessary and identify by block number) A closed, vacuum tight animal maintenance system has been devised that enables recovery of very small amounts of respiratory ¹⁵ N over extended periods. Animals with indwelling cannulas for injection and sampling are placed in a closed, circulating atmosphere of 75% SF ₆ / 25% O ₂ . CO ₂ is removed in a soda lime trap, and O ₂ is added by a peristaltic pump controlled by a pressure sensitive switch. At the time of collection the animal is euthanized and the atmosphere is circulated through a pyrogallol trap to remove most of the oxygen, then transferred			

406 810
78

11 28 019

2002
JP

by temperature gradient to a high vacuum system where SF_6 is frozen out. The remaining oxygen is removed by passage through a reaction column and the ^{15}N is trapped at liquid nitrogen temperature on activated carbon in a removable gas-tight trap. The trap contents are then analyzed by mass spectroscopy. About 15% of administered ^{15}N -hydrazine was converted to $^{15}N_2$. The conversion was very rapid after a single dose, and did not increase appreciably over several hours even though hydrazine was detectable in blood.

↳ Preliminary studies of the disposition of intact hydrazine and its derivatives in rats are described. Substantial amounts of a metabolite tentatively identified as diacetyl hydrazine were found in urine. During continuous infusion of hydrazine, some animals maintained a constant blood hydrazine level, others were unregulated and experienced a continuous increase for the duration of infusion.

SUMMARY

A closed, vacuum tight animal maintenance system has been devised that enables recovery of very small amounts of respiratory ^{15}N over extended periods. Animals with indwelling cannulas for injection and sampling are placed in a closed, circulating atmosphere of 75% SF_6 /25% O_2 . CO_2 is removed in a soda lime trap, and O_2 is added by a peristaltic pump controlled by a pressure sensitive switch. At the time of collection the animal is euthanized and the atmosphere is circulated through a pyrogallol trap to remove most of the oxygen, then transferred by temperature gradient to a high vacuum system where SF_6 is frozen out. The remaining oxygen is removed by passage through a reaction column and the ^{15}N is trapped at liquid nitrogen temperature on activated carbon in a removable gas-tight trap. The trap contents are then analyzed by mass spectroscopy. About 15% of administered ^{15}N -hydrazine was converted to $^{15}\text{N}_2$. The conversion was very rapid after a single dose, and did not increase appreciably over several hours even though hydrazine was detectable in blood.

Preliminary studies of the disposition of intact hydrazine and its derivatives in rats are described. Substantial amounts of a metabolite tentatively identified as diacetyl hydrazine were found in urine. During continuous infusion of hydrazine, some animals maintained a constant blood hydrazine level, others were unregulated and experienced a continuous increase for the duration of infusion.

PREFACE

The research reported herein is conducted in the Department of Agricultural Chemistry, Oregon State University, under contract F33615-77-C-0500. The principal investigator is Dr. F.N. Dost. Contract monitor for 6570th Aerospace Medical Research Laboratory is Dr. Kenneth C. Back, Chief, Toxicology Branch, Toxic Hazards Division.

ADMISSION IN	
NTIS	White Section <input checked="" type="checkbox"/>
DOC	Buff Section <input type="checkbox"/>
UNANNOUNCED	<input type="checkbox"/>
JUSTIFICATION	
BY	
DISTRIBUTION/AVAILABILITY CODES	
DIAL	AVAIL. DOC/SP. SPECIAL
A	

INTRODUCTION

The objective of the first year of work has been to devise a method for detecting and measuring $^{15}\text{N}_2$ as a metabolite of ^{15}N -hydrazine, and to achieve a general body inventory of hydrazine nitrogen following administration to rats.

The work has proceeded on two fronts. The first has required development of methodology for detection of very small amounts of $^{15}\text{N}_2$ evolved from intact rats or tissue preparations, followed by experiments to identify $^{15}\text{N}_2$ as a metabolite of ^{15}N -hydrazine.

The other thrust is to measure some kinetic characteristics of unlabeled intact hydrazine during and after single injections and continuous infusions to rats. Existing methods have been adapted to enable micro determinations of hydrazine that permit serial blood analyses in individual animals, and differentiation of hydrazine and at least some of its derivatives.

The existing history of study of hydrazine metabolism has not been extended since the proposal for this work was developed. It is short and may be usefully repeated here:

McKennis et al. (1955) found that a variable but substantial amount of hydrazine emerged in urine of dogs within 48 hours after acute dosage with 15 mg/kg hydrazine, a treatment which is frequently lethal. In later work (McKennis et al., 1959), hydrazine was found to be diacetylated to a considerable extent by the rabbit, but only minimally by the dog. Elevation of blood ammonia by hydrazine (McKennis and Weatherby, 1956) suggests that some hydrazine can cause alteration in ammonia metabolism or even may proceed to formation of ammonia. Studies of intact rabbits and isolated rat tissues have suggested that hydrazine may be converted enzymatically to ammonia in vivo (Procellati and Preziosi, 1954).

Dambrauskas and Cornish (1964) followed the time course of tissue levels and excretion of hydrazine as measured spectrophotometrically following reaction with p-dimethylaminobenzaldehyde. Hydrazine continued to appear in urine for 20 hours or more after a single injection, and tissue concentrations decreased steadily over the same period. About 50% of the administered hydrazine could not be found in either tissues or urine, and was assumed to have been metabolized. The amount "metabolized" was almost constant throughout the time course, indicating that it was either lost experimentally or was not subject to the apparently time-consuming processes mediating removal of nominally intact hydrazine from tissues.

Very few in vivo chemical reactions of hydrazine have been documented. McKennis et al. (1959) observed significant diacetylation of hydrazine in rabbits but found that such conversion in the dog was limited. Acetylation of many hydrazine derivatives, notably isoniazid, is known to be genetically determined within humans (Evans et al., 1960; Dufour et al., 1964) and possibly other species, and the significance to other hydrazine reactions of such differences in this pathway can only be speculated upon. Hydrazine is a carbonyl reagent and is generally accepted as a reactor in vivo with pyridoxal phosphate and possibly other aldehydes and ketones. Hydrazine was used in

studying the physiology and chemistry of hemoglobin around the turn of the century; the reaction was stated by Buckmaster (1913, 1914) to form gaseous nitrogen.

In view of the incomplete inventories of previous studies, we have suggested the possibility that much of the "lost" hydrazine may be accounted for as nitrogen gas, and have designed the program to answer that question first. We have found that about 15-20% of a one mmole ^{15}N -hydrazine dose/kg given to rats will emerge very quickly as $^{15}\text{N}_2$. Small amounts of hydrazine vapor also apparently emerge following parenteral administration.

DISPOSITION OF ^{15}N HYDRAZINE IN EXPERIMENTAL ANIMALS

METHODS

Description of the Animal Metabolism System and Vacuum Line

In design of the animal metabolism chamber, several requirements were obvious. The system should: 1) utilize a filling gas that is condensible or otherwise separable, and non-toxic; 2) be able to withstand substantial vacuum; 3) be designed to permit acute or continuous injection of intoxicants or other agents to experimental animals without opening the system; 4) have a sensitive, demand-driven oxygen supply; and 5) include CO_2 and water traps that do not otherwise compromise the experimental atmosphere.

There must be associated capability to remove oxygen, remove the bulk condensible gas, trap ^{15}N or other noncondensable gases, and move them to a mass spectrometer for analysis.

The system includes an animal chamber, soda lime and Drierite traps for CO_2 and water, a circulatory pump, an O_2 replenishing system, and a source of sulfur hexafluoride (SF_6), the bulk gas of the system (Figure 1). The components were designed and fabricated locally, and assembled with "O" ring joints. Soda lime and Drierite traps were made of 2 inch Pyrex pipe, with "O" ring joints which are clamped with bolted flanges to assure a gas-tight seal. Demountable components are joined by hand-tightened Ultratorr fittings (Cajon Company). Stainless steel flexible joints (Cajon Company) are used where flexibility was necessary.

The animal chamber was constructed in two pieces from 3-1/2" Corning Pyrex sewer pipe, using the standard joint and clamp with a Teflon gasket for vacuum seal. The chamber has a removable urine trap, a port for insertion of a watering tube, and a port for gas-tight entrance of cannulas. (Indwelling cannulas are connected to needle stock inserted through a thick soft rubber stopper at the top of the chamber.)

The O_2 replenishing system is controlled by a mercury manometer pressure switch, which in turn activates a relay to the peristaltic oxygen pump. The pump draws from a large reservoir of polyethylene film maintained at slightly more than ambient pressure. Ultrapure oxygen (99.995% O_2 ; Airco Products) is used in all phases of this study to prevent build up of argon which is noncondensable and may accumulate in sufficient volume to interfere with

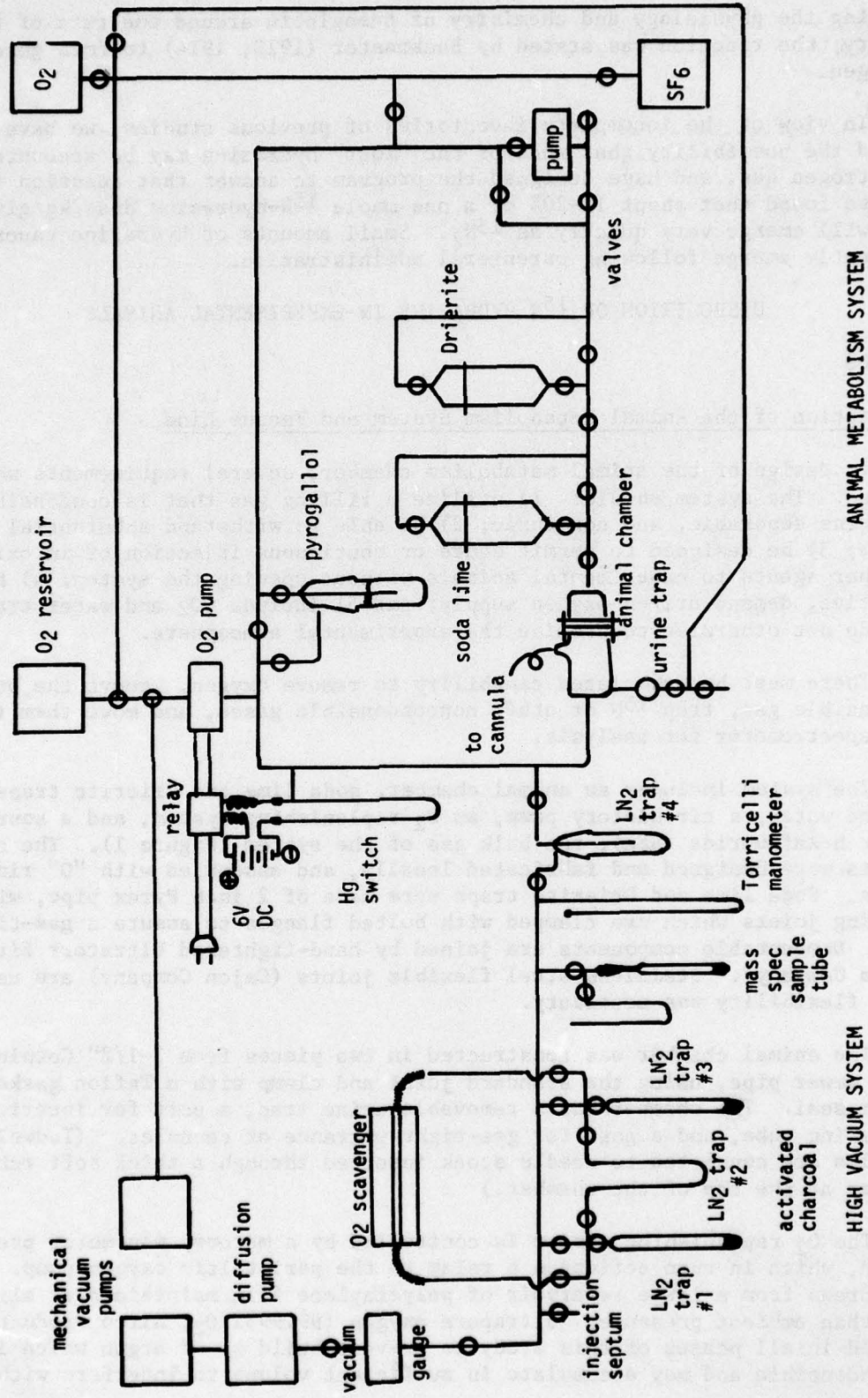

Figure 1 Schematic of closed animal system for collection of respiratory gases and vacuum manifold for gas separation.

$^{15}\text{N}_2$ collection at the end of the experimental period. Currently, we are applying slight positive pressure within the polyethylene bag by a continuous flow (25 ml/min) of O_2 to reduce the potential for inward diffusion of atmospheric nitrogen. We have found that by maintaining a low backing pressure directly from the oxygen tank to the peristaltic pump (2-5 psi), the pump serves as a regulator, is leak tight, and greatly reduces $^{14}\text{N}_2$ contamination. This simpler system is now being installed.

The vacuum system was modified extensively from a portable high vacuum system (Delmar Scientific Laboratories, Inc.). The primary manifold was constructed according to Figure 1 from 1" glass tubing with vacuum valves from Kontes Glass or J.T. Young. Where rapid attachment and removal of components was necessary, 3/8" Ultratorr connectors (Cajon Company) were employed.

Mass spectrometer sample tubes were constructed according to Figure 2 and were usually loaded with 1.0 g charcoal. This construction enables sample storage for several days and allows easy transport to the mass spectrometer.

Animals and Administration of Chemicals

Male Sprague-Dawley rats weighing 250-300 g were utilized in all experiments. An indwelling intraperitoneal cannula was employed in each animal, with the external end emerging in the dorsal neck area. At the time the animal was placed in the chamber, the cannula was connected to a hubless

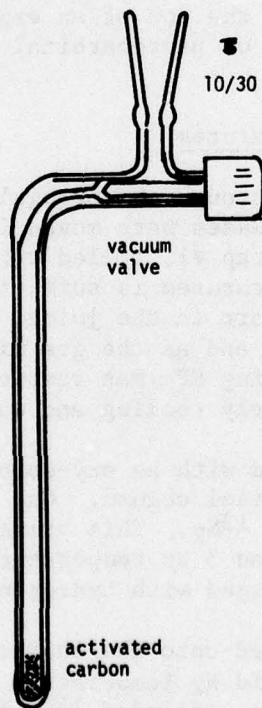

Figure 2 Mass spectrometer sample transfer tube

needle inserted through the rubber stopper in the cannula port, and tubing was similarly attached on the outside. This arrangement will accommodate several cannulas if required. Hydrazine or other agent was administered as a single dose or as a continuous infusion. Hydrazine as the base and hydrazine sulfate (^{15}N or ^{14}N) were diluted or dissolved in glass distilled water and pH was adjusted to about 4 for stability during brief storage and injection.

Preparation and Start-Up of an Experiment

It is essential to prepare each of the components of the system in the proper sequence to prevent inward leakage of atmospheric gases. Before each experiment the charcoal traps were heated for 5 minutes with a 500°F heat gun while being evacuated to remove any gases remaining on the charcoal from previous experiments. The pyrogallol (PGA) trap to be used for oxygen scavenging at the end of the experiment was filled with 200 ml of aqueous 50% KOH containing 30 g of pyrogallol acid, flushed for 10 minutes with SF_6 (1.0 l/min), and attached according to Figure 1. The animal was then placed in the restrainer and inserted into the animal chamber which was flushed for 15 minutes with 100% O_2 to remove atmospheric gases, with care to avoid excessive pressure changes. The remaining portion of the system was then evacuated and refilled with O_2 . With the circulating pump operating, the entire animal system was flushed for 10 minutes with 100% O_2 , then with a 1:4 mixture of O_2 - SF_6 for an additional 15 minutes at a flow rate of 1.25 l/min. The system was closed, the oxygen supply switched on, and the gases circulated continuously throughout the duration of the experiment. At present, single experiments range from 1-24 hours. At the end of an experiment the animal was euthanized, usually by injection of pentobarbital through an indwelling cannula.

Removal and Separation of Gas Mixtures

The atmosphere was cycled through the pyrogallol trap for 15 minutes, which removes > 90% of the O_2 . Gases were moved from the animal system into the vacuum manifold by cooling trap #1, filled with activated carbon. The adsorptive capacity at low temperatures is sufficient to generate negative pressures on the order of 10^{-3} torr in the joined systems. Traps 2 and 4 were also cooled with liquid nitrogen and as the gas mixture passed through, most of the SF_6 was removed. Any remaining SF_6 was removed by one or more additional passes across trap 2 by alternately cooling and warming traps 1 and 3.

The remaining O_2 was removed with an oxy-sorb (Altech Associates) column heated at 200°C in a stainless steel column. One pass was sufficient to remove the remaining O_2 without loss of $^{15}\text{N}_2$. This transfer was also powered by movement in and out of traps 1 and 3 by temperature shifting with liquid N_2 . The oxy-sorb column can be recharged with hydrogen gas at 135°C for 2 hrs.

The residual gases were moved onto the charcoal of the mass spectrometer sampling tube (Figure 2) at liquid N_2 temperature and the volume estimated manometrically. The gas remaining included $^{15}\text{N}_2$ from administered ^{15}N -hydrazine sulfate, $^{14}\text{N}_2$ and O_2 leaked in from the atmosphere, small amounts of CH_4 from bacterial metabolism, and argon as an O_2 impurity, with a total volume up to 25 ml during a 20-24 hr experiment. If needed, $^{14}\text{N}_2$ was added to bring the total volume to 25 ml, the valve closed and the device detached

for transport to the mass spectrometer. The 25 ml volume is near the maximum volume that can be accepted by the mass spectrometer without loss of linearity of response. Leakage occurring over the course of an experiment can theoretically be tolerated to that extent.

Mass Spectrometer Quantitation

The mass spectrometer used in this program is a Varian CH 7 with a sample cavity volume of about 1.5 liters. The entry into the "batch cell" is small enough that an insignificant amount of gas is lost over a 10 to 15 minute measuring cycle. Our procedure was to allow sample into the cell, record a mass spectrum, draw the cell volume back into the sample tube at liquid N₂ temperature, and then release the sample back into the mass spectrometer for another measurement. If the mass ratios are similar and if the ¹⁵N₂ net masses are similar in the two measurements they were accepted and the valves closed. ¹⁵N₂ may be used as an internal standard by connecting a sample tube containing 1 ml ¹⁵N gas to the instrument after the unknown has been pulled into the sample cavity and then "washed" into the mass spectrometer to mix with the unknown. While the system varied in response with volume of sample, the one ml addition did not cause a significant deviation due to volume change.

There is an inherent variability in the output of the mass spectrometer which is designed for compound identification but not quantitation. Under these circumstances, the most convenient method for mass measurement is based on an internal standard or "spike". We find that either ¹⁵N₂ or neon (non-condensable), or Freon-14 (CF₄) (condensable) were useful, and other gases could probably also be used. As an example, a known volume (usually one ml) of Freon-14 was injected into the vacuum manifold just prior to collection of the unknown gas sample into the mass spectrometer tube.

Gases for standardization were volumetrically measured with disposable plastic syringes, using 23 gauge, 3 1/2 inch long needles to reduce exchange with the atmosphere. This method was simple and more accurate than standard vacuum line techniques. All volumetric measurements were corrected to standard conditions. The major masses observed for Freon-14 were m/e 69 (CF₃⁺) and m/e 50.

To establish the validity of such methods (room temperature and atmospheric pressure) a standard curve was prepared with constant volumes of Freon-14 (1.0 ml) and volumes of ¹⁵N₂ varied between 0.25 ml and 2.5 ml. The total sample volume is adjusted with ¹⁴N₂ to 25 ml in each case. The ratio of mass spectrometer output for m/e 30 to m/e 69 plotted against the volume of ¹⁵N₂ was linear. All values were ultimately corrected for standard conditions.

Capability for recovery of ¹⁵N₂ from the entire animal system was evaluated by injecting a known volume of ¹⁵N₂ through a diaphragm into the animal system containing a typical test atmosphere, circulating for 2 hours followed by transfer and measurement as described. The amount of ¹⁵N₂ recovered was greater than 95%.

Chemicals

Sulfur hexafluoride, 99.8%, and carbon tetrafluoride, 99%, were obtained from Matheson Gas Products, East Rutherford, NJ; hydrazine sulfate ¹⁵N (99.1

TABLE 1
 CONVERSION OF A SINGLE IP DOSE OF 1 MMOLE/KG
¹⁵N-HYDRAZINE/KG TO ¹⁵N₂ BY RATS

Rat Weight (g)	Dose ¹⁵ N-Hydrazine Sulfate (mmole)	Collection Time (hr)	Amount ¹⁵ N ₂ Collected		% of Dose Converted to N ₂
			ml STP	mmole	
310	.31	1	.92	.041	13.2
295	.30	1	1.0	.045	15.1
210	.20	4	.56	.025	12.5
245	.24	4	.52	.023	9.6
250	.25	4	.58	.026	10.3
230	.23	4	.89	.039	17.2
280	.28	12	.96	.042	15.3
220	.22	20	.82	.037	16.6
Average					13.7

atom %) and ¹⁵N nitrogen, 99 atom % (Prochem) from U.S. Services, Inc., Summit, NJ; oxygen (ultra-pure) from Liquid Air Inc., San Francisco, CA; oxy-sorb from Altech; Drierite from W.A. Hammond Drierite Co., Xenia, Ohio; Sodasorb (soda lime) from Dewey & Almy, Cambridge, MA; activated carbon, type Cal 12 x 40 from Calgon, Pittsburgh, PA; and pyrogallic acid from Mallinckrodt. All other chemicals were reagent grade.

RESULTS

Single Dose

Animals administered a single dose of 1.0 mmole ¹⁵N-hydrazine sulfate per kg body weight through an implanted intraperitoneal cannula converted approximately 14% of the administered hydrazine to nitrogen gas (Table 1). The respiratory gases were collected for 1, 4, 12, or 20 hours; the similarity of recovery at various times after administration suggests a very rapid initial conversion with little or no further reaction.

Infusion

Two rats administered 2 mmole ¹⁵N-hydrazine sulfate per kg body weight over a 6 hr period converted 12.4% and 15.2% of the dose to ¹⁵N₂ in 8 hours (Table 2). There appears to be little difference in ¹⁵N₂ production between single injection and infusion experiments but the limited number of infusion observations does not permit a conclusion.

Whole Blood Metabolism of Hydrazine

The mechanism and site of the metabolic reaction may involve hemoglobin or other heme proteins. Incubation of ¹⁵N-hydrazine in heparinized whole

TABLE 2
 CONVERSION OF ^{15}N -HYDRAZINE TO $^{15}\text{N}_2$ BY RATS DURING AND AFTER
 CONTINUOUS IP INFUSION OF 2 MMOLE/KG OVER SIX HOURS
 (gases were collected over 8 hr from beginning of infusion)

Rat Weight (g)	Dose ^{15}N -Hydrazine Sulfate (μmole)	Amount $^{15}\text{N}_2$ Collected		% of Dose Converted to $^{15}\text{N}_2$
		ml STP	μmole	
280	.23	.64	.028	12.4
275	.23	.80	.035	15.2

blood in an ($\text{O}_2:\text{SF}_6$; 1:4) atmosphere at 37°C for 3 hours converted 9-10% of the hydrazine to $^{15}\text{N}_2$. Further measurements in presence and absence of oxygen are in progress.

PROBLEMS IN DEVELOPMENT OF EXPERIMENTAL METHODS

Leakage

Assembly and operation of a high vacuum system is inevitably accompanied by many leaks, a few of which usually defy location. Among other interesting difficulties, we encountered a batch of heavy vacuum tubing that was quite permeable at pressures below 10^{-2} torr. In the initial stages of the work, problems of this kind consumed a significant amount of time.

Leakage in the animal system is a major problem because many joints are of large cross section and must be taken apart frequently. There appears to be little exchange during collection periods, because the pressure gradient across the chamber wall is essentially zero. At the time of transfer, however, all of the joints must "set" quickly when vacuum is applied and in this phase the potential for leakage is high unless the entire assembly is carefully prepared. As methods have developed we find that we can accommodate 25 and possibly as much as 40 ml of non-condensable gas per sample without loss of measurement integrity. As a consequence we can tolerate limited leakage, although with increased duration the tolerance becomes more critical.

O₂ Removal for Samples

Initially, O_2 was effectively removed with a Supelco oxygen scavenging column at 450°C but 20% to 60% of the $^{15}\text{N}_2$ was also lost, apparently by oxidation. The reaction with O_2 in that system is exothermic and unless oxygen entry is carefully controlled the stainless steel support tubing will fuse or burn. Column temperature must be lowered to 320°C to prevent destruction of the column but O_2 then does not react adequately; the method was abandoned.

Mass Spectrometer Variability

The mass spectrometer available is designed primarily for identification and structure determination for volatile organic molecules. The output from this instrument is determined by the ionization energy for a given fragment. $^{15}\text{N}_2$ is a simple molecule with two possible species visible to the mass spectrometer, m/e 30, $^{15}\text{N}_2^+$ and m/e 15, $^{15}\text{N}^+$. For a given amount of $^{15}\text{N}_2$ the mass spectrometer output for m/e 30 and m/e 15 will be constant if no changes occur internally in the instrument (constant focus, basic fluctuation, etc.). Since we are using the mass spectrometer as an analytical tool it is critical that the output be reproducible within a given experiment. We have observed considerable variability (coefficient of variation of 0.2) when comparing output for m/e 30 for several standards. The output is altered by pressure changes which are dependent on sample size among other variables and by composition of the sample gases. In an effort to overcome this problem, we have experimented with various internal standards, particularly Freon-14 or neon, added to the sample before transfer to the mass spectrometer. Freon-14 (carbon tetrafluoride) has the advantage of adsorbing to charcoal at liquid N_2 temperature and desorbing at 200°C . This method still occasionally gives us erratic results and we are attempting other internal standard systems.

Presently we are also evaluating other sources of variability in the instrument and in sample preparation. A critical cause of sample variability is an unclean electron source in the instrument. Diligent attention to that problem has aided our precision.

Potential Errors in Sources of Observed ^{15}N

When hydrazine- ^{15}N is injected and we find $^{15}\text{N}_2$ in chamber gases it is fair to assume that the $^{15}\text{N}_2$ is biological in origin. We must, however, demonstrate that it did not arise from exhaled hydrazine that was then degraded non-enzymatically in the chamber. In part this can be resolved by observing degradation of hydrazine placed in the animal system, without an animal, but with a water laden atmosphere, and all traps and accessories in place. We have been unable to demonstrate ^{15}N -hydrazine conversion to $^{15}\text{N}_2$ in these circumstances.

DISPOSITION OF INTACT UNLABELED HYDRAZINE IN BLOOD, TISSUES, AND URINE OF EXPERIMENTAL ANIMALS

In parallel with investigations of the fate of the nitrogen of hydrazine, we are also measuring levels of intact hydrazine in blood, urine, and tissues under various experimental conditions. In tissues particularly, any differences between distribution of ^{15}N and intact hydrazine will be quite informative as we design studies of ^{15}N binding within cells.

The observations of hydrazine distribution have been made following administration of single doses and continuous infusion of hydrazine over several hours. The assays have measured both hydrazine and a further fraction that emerges in the samples following acid hydrolysis. We assume, pending mass spectroscopic analyses, that the component yielding hydrazine upon hydrolysis is di- and/or monoacetyl hydrazine.

METHODS

Hydrazine concentrations in whole blood, urine, and tissue extracts are determined by a modification of the method of Reynolds and Thomas (1965), employing p-dimethylaminobenzaldehyde (DMBA) as a color reagent. DMBA (Eastman), 10% in 100% ethanol, is slightly yellow, but is satisfactory for our purposes without further purification. Standard hydrazine solutions are prepared from the 99+% free base as supplied (Eastman).

Blood is diluted with distilled water (0.1 ml blood/0.3 ml water) to rupture cells. 1.0 ml trichloroacetic acid (10% aqueous) is added, mixed, and the sample centrifuged to precipitate protein. One ml of the supernatant is added to 2 ml DMBA solution, the mixture is incubated 20 minutes at room temperature, and absorbance is read at 470 nm. Samples must be read within two hours; a slight fading of color begins after about 20 minutes. In most use, 0.03 and 0.06 μg hydrazine in 0.4 ml rat serum are the working standards and are processed in the same way.

The assay is linear between 0.2 and 3.0 μg hydrazine (0.006–0.09 μmoles) and detectability extends considerably lower.

Urine samples are measured, frozen, and stored at -80°C . At the time of analysis samples are diluted with TCA according to a quick range finding test to a known volume so that concentration of hydrazine will be no more than 2 $\mu\text{g}/\text{ml}$ (TCA concentration must be at least 7%). The color reaction is measured as described above.

There are some interfering substances in urine; we have established that urea produces the same interference in water solution or when added to urine, but we have not proven the identity of urea in urine. Until this can be accomplished we consider our urinary analyses as estimates only. Preliminary findings indicate that urease treatment eliminates most of the interferences.

Hydrolyzable hydrazine derivatives in urine (probably diacetyl hydrazine) are released by a modification of the methods reported for diacetyl hydrazine (Ellard et al., 1972; Peters et al., 1965) then analyzed for hydrazine as already described. Additional reagents are 2 N HCl and diacetyl hydrazine prepared according to Twiner (1947).

Diacetyl hydrazine standards of 0.03 and 0.06 $\mu\text{m}/0.5$ ml are prepared. To unknowns, controls, and standards is added 0.5 ml of 2 N HCl and the samples are incubated 48 hours at 45°C and analyzed as above. (Incubation for 24 hours is suggested in the literature, but hydrolysis does not appear complete at 24 hours in our use. Hydrazine as it exists in urine is stable at least 24 hours under these conditions.)

Two ml DMBA is added to each tube after cooling and the analysis carried out as described.

It is important that parallel determination of hydrazine in hydrolyzed and non-hydrolyzed samples be made at the same time to establish the respective levels of the acetylated and nonacetylated hydrazine.

Tissue samples are cut into small pieces, on ice, frozen as soon as possible in liquid N₂, then stored at -80°C. At the time of assay, samples are further cooled with liquid N₂ and ground in a cold mortar. Samples are then extracted for 10 minutes with TCA and centrifuged at 22,000 g for 20 minutes. Any particles suspended in the supernatant fluid are removed with a millipore filter. Samples can be stored at -80°C at this point if desired. A 1 ml aliquot is analyzed as described; if necessary TCA can be used as a diluent.

RESULTS

Assays of blood levels of hydrazine during continuous infusion showed that in some animals blood hydrazine concentration rises continuously throughout the six hour infusion period (Figure 3). In others, the hydrazine concentration reaches a relatively constant level. As an early interpretation, the difference suggests that there may be two populations with respect to hydrazine excretion or metabolism. We have measured urinary output and blood levels simultaneously in only two animals thus far, one with low blood hydrazine and one high with excretion higher in the former. (¹⁵N₂ data showed no evidence of two classes of metabolism.) In animals that maintain a relatively constant blood hydrazine level during infusion, the relation between dose rate and blood concentration appears approximately linear. A series of experiments is in progress to observe blood hydrazine levels at lower rates of infusion over periods longer than 6 hours; early results indicate that at low dose rates a steady hydrazine concentration can be maintained by some animals for at least 12 hours.

Tissue hydrazine concentrations have been measured after continuous infusion for varying periods. In one series the infusion rate was 3 mmole/kg/6 hr (0.5 mmole/kg/hr); animals were sacrificed after total doses of 0.3, 1.0, and 3.0 mmole/kg. In the other the rate was 3 mmole/kg/8 hr (0.375 mmole/kg/hr). In the first group the animals received total doses of 0.4, 1.0, and 2.0 mmole/kg. In each series, concentration of hydrazine in kidney and liver appeared linearly related to total dose (Figure 4). The limited study so far completed may indicate that infusion rate also governs tissue accumulation in liver but not kidney, but the data as yet is too scanty to justify such an observation. Tissues from a larger number are stored for later analysis, to determine if possible whether some discrete range of tissue and blood hydrazine concentrations is associated with the appearance of gross toxicity.

Very little hydrazine, as such, was found retained in brain, gut, or muscle. Concentration in the kidney was highest of all tissues, and blood was the only tissue with a total burden of more than 1% of dose.

Urinary excretion accounted for almost all of the free or acetylated hydrazine and the total recovery was about 36% of a single injection of 1 mmole/kg and about 55% of a similar dose extended over 6 hours.

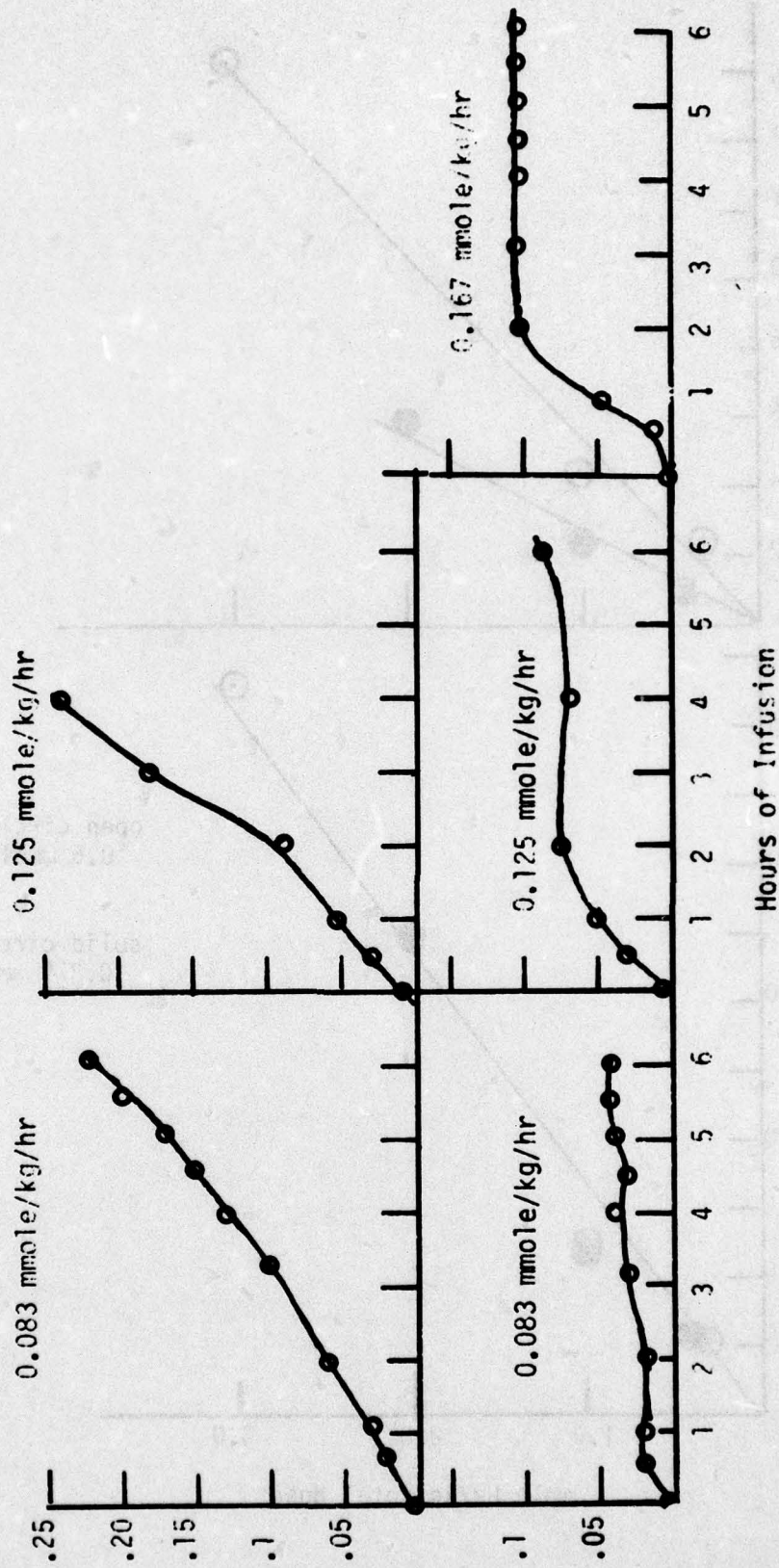

Figure 3 Blood levels of hydrazine during continuous infusion

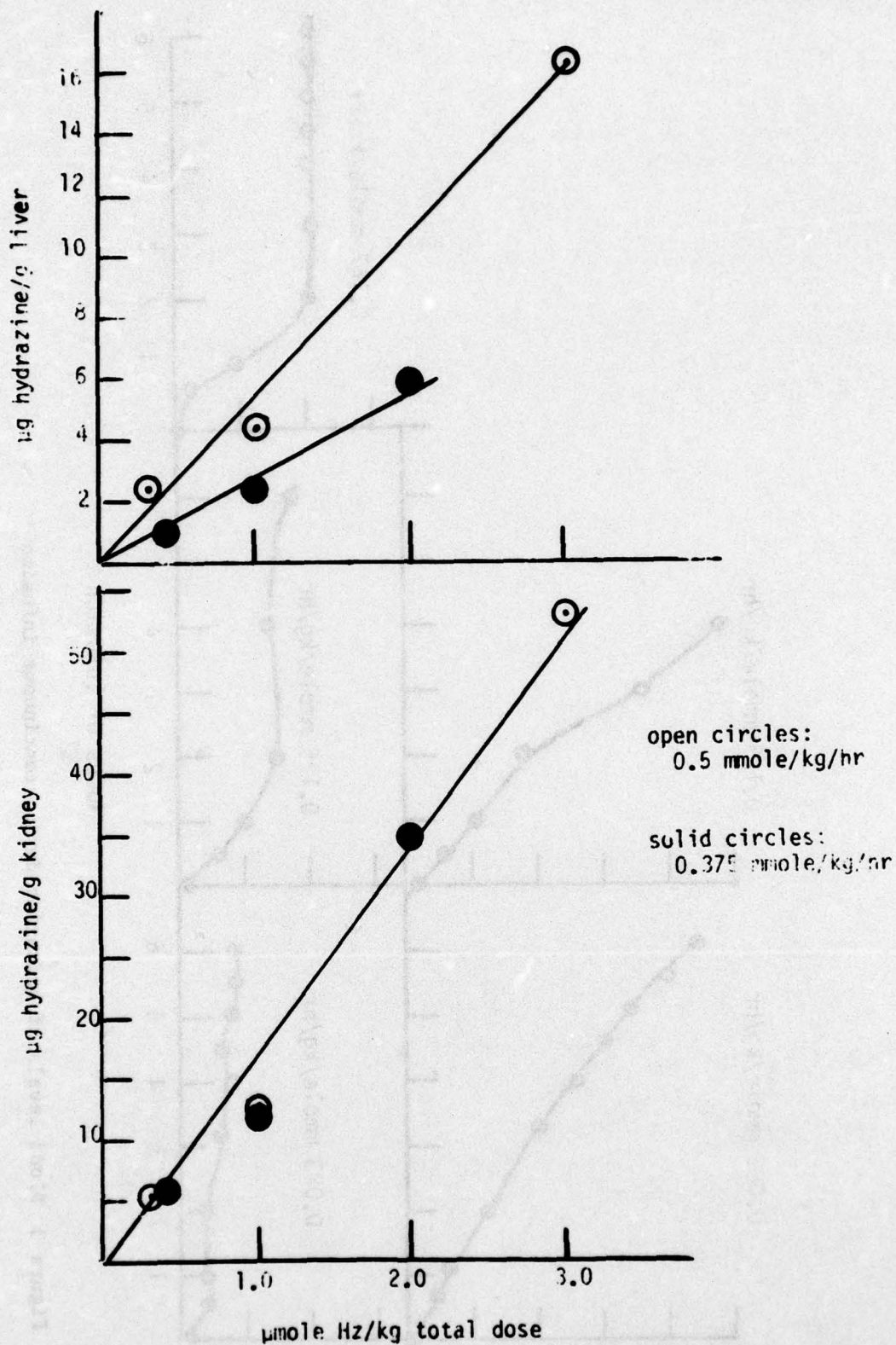

Figure 4 Tissue hydrazine concentration at the end of varying periods of infusion relative to total hydrazine administered

When the data from animals given either single doses or six hour infusions of ^{15}N hydrazine are added to the above data, total accountability is about 70% following infusion, and about 55% following single doses. A number of potential components have yet to be examined, the most important of which are ammonia, and urea.

The disposition of intact hydrazine in blood, tissues, and urine following a single injection of one mmole/kg and the same amount infused continuously over a six-hour period were compared.

Neither liver nor kidney hydrazine concentrations were appreciably affected by the mode of administration in the limited number of animals studied. Blood of continuously infused rats, as expected, contained less hydrazine than those given a single injection. The pooled remaining tissues contained approximately similar concentrations. Muscle, stomach, and small intestine were assayed and contained in most cases less than 0.1% of the total administered. Total urinary hydrazine and diacetyl hydrazine differed substantially in animals given 1 mmole/kg. The two continuously infused rats converted 22.5 and 20.4% to the presumed diacetyl derivative and about 33.5 and 31.5% emerged unchanged as hydrazine. Singly dosed animals converted 13.5 and 11.7% to acetylhydrazine and excreted 23.5 and 23% unchanged. The ratio of hydrazine to acetyl hydrazine was about the same in both pairs.

Blood hydrazine concentration was measured periodically following termination of an infusion of 0.166 mmole/kg/hr to two animals (Figure 5). Hydrazine concentrations decreased steadily but measurable levels remained in blood for many hours after infusion stopped.

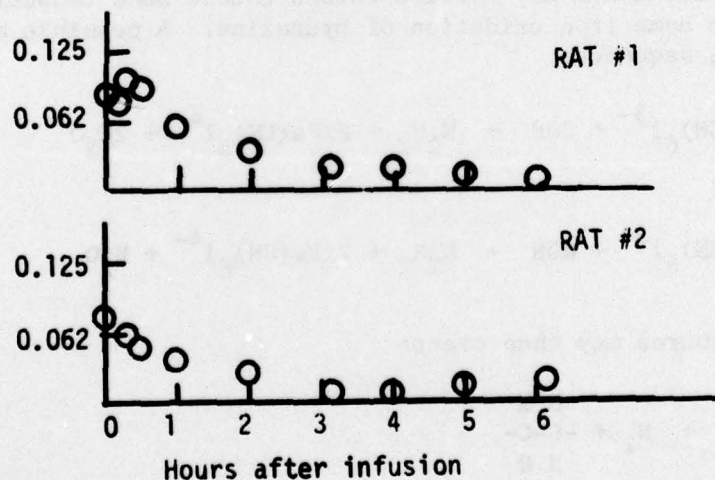

Figure 5 Disappearance of hydrazine from blood following infusion of two rats of 0.167 mm/kg/hr for six hours

DISCUSSION

The rapid evolution of ^{15}N following hydrazine administration and the relatively constant but limited conversion regardless of dose rate is somewhat paradoxical. Such rapid conversion should hardly be expected to stop abruptly if it arises from an enzymatic process.

One immediate suspicion of rapidly reacting impurity in the ^{15}N -hydrazine was considered. Hydrazine analysis of ^{15}N -hydrazine sulfate, ^{14}N -hydrazine sulfate and the 99+% hydrazine base showed that all were of similar purity on a molar basis within the limits of the variability of the analytical method. It should be recalled that Dambrauskas and Cornish (1964), in observing disappearance of administered hydrazine, suggested that some kind of metabolic degradation of hydrazine proceeded rapidly for 30-120 minutes and then stopped abruptly.

The schemes by which ^{15}N might arise from hydrazine were reviewed in the proposal for this study. We have suggested the possibility of a pathway that may include intermediate formation of diimide (H-N=N-H) (also known as diazene). Hydrazine oxidation to nitrogen by two electron transfer agents has been described by Higgenson et al. (1953) as quantitative, proceeding through diimide formation. Nitrogen will arise from diimide, but ammonia cannot. Most important in our studies, one-electron transfer agents give a variable stoichiometry, with the two qualitative pathways as follows:

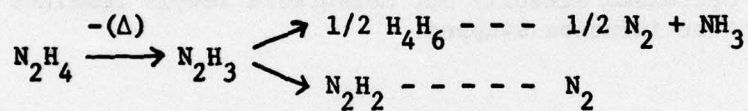

A second possible mechanism may involve carbon double bond reduction, possibly coupled with heme iron oxidation of hydrazine. A possible model may have the following sequence:



or



N_2H_2 from either source may then react:

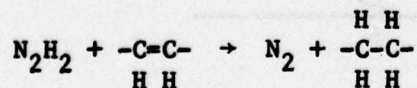

The explanation for the peculiar kinetics of ^{15}N appearance may lie in the experiments of Higgenson et al. (1953) who laid out a split pathway for an "activated" N_2H_3 formed from hydrazine. They found that any hydrazine passing through the diimide step was committed to nitrogen formation. It may be that an early "sorting" of N_2H_3 to N_2H_2 or $1/2 \text{N}_4\text{H}_6$ as proposed may account for the rapid yet discrete formation of N_2 .

Blood concentration of hydrazine during infusion may indicate two populations of animals with respect to metabolism or excretion. These experiments are intended for range finding and because of dosage differences cannot be strictly compared.

STUDIES PLANNED FOR YEAR TWO

DISPOSITION OF ^{15}N -HYDRAZINE IN EXPERIMENTAL ANIMALS

1. Establish time course of production of $^{15}\text{N}_2$ following single IP doses. Present work indicates this process may be complete within 30 minutes.
2. Determine the role of liver in this process by comparing intraportal and subcutaneous administration, and in animals pretreated with phenobarbital for induction of mixed function oxidases.
3. Evaluate all possible non-biological oxidative routes, although present evidence suggests that this kind of reaction is not significant.
4. Conduct in vitro studies with oxygenated and deoxygenated blood. Blood is capable of $^{15}\text{N}_2$ formation from hydrazine, but the effect of oxygenation status has not been established.
5. Determine the extent of ^{15}N ammonia and ^{15}N urea formation.
6. Inventory total ^{15}N arising from ^{15}N hydrazine in tissues and sub-cellular fractions.

The latter two objectives will utilize the Kjeldahl-Rittenberg technique as modified by Ross and Martin (1970) and Porter and O'Deen (1977).

DISTRIBUTION AND EXCRETION OF CHEMICALLY INTACT HYDRAZINE

1. Excretion of intact hydrazine in respiratory gases. (Initial experiments suggested limited exhalation, more precise later experiments have been negative.)
2. Complete measurements of intact hydrazine concentration in tissues at various dose levels.
3. Establish blood levels of hydrazine during continuous infusion over long periods at lower dose rates.
4. Determine blood level of hydrazine corresponding to onset of symptoms in rats.

REFERENCES

- Buckmaster, G.A. (1913). The behavior of blood with hydrazin hydrate. Jour. Physiol. (Proceedings) 46:XIVIII.
- Buckmaster, G.A. (1914). Action of hydrazine hydrate on methemoglobin. Jour. Physiol. (Proceedings) 48:XXV.

- Dambrauskas, R., and H.H. Cornish (1964). The distribution, metabolism, and excretion of hydrazine in rat and mouse. *Toxicol. Appl. Pharmacol.* 6:653.
- Dufour, A.P., R.A. Knight, and H.W. Harris (1964). Genetics of isoniazid metabolism in Caucasian, Negro, and Japanese populations. *Science* 145: 391.
- Ellard, G.A., P.T. Gammon, and S.M. Wallace (1972). The determination of isoniazid and its metabolites acetylisoniazid monoacetylhydrazine, diacetylhydrazine, isonicotinic acid, and isonicotinylglycine in serum and urine. *Biochem. J.* 126:449.
- Evans, D.A.P., K.A. Manley, and V.A. McKusick (1960). Genetic control of isoniazid metabolism in man. *Br. Med. Jour.* II:485.
- Higginson, W.C.E., D. Sutton, and P. Wright (1953). The oxidation of hydrazine in aqueous solution. Part I. The nature of 1- and 2-electron-transfer reactions, with particular reference to the oxidation of hydrazine. *J. Chem. Soc.* 1953:1380.
- McKennis, H., J.H. Weatherby, and L.B. Witkin (1955). Studies on the excretion of hydrazine and metabolites. *J. Pharm. Exptl. Therap.* 114:385.
- McKennis, H., and J.H. Weatherby (1956). Blood ammonia following administration of various hydrazino compounds. *Fed. Proc.* 15:458.
- McKennis, H., A.S. Yard, J.H. Weatherby, and J.A. Hagy (1959). Acetylation of hydrazine and the formation of 1,2-diacetylhydrazine in vivo. *J. Pharm. Exptl. Therap.* 126:109.
- Peters, J.H., K.S. Miller, and P. Brown (1965). Studies on the metabolic basis for the genetically determined capacities for isoniazid inactivation in man. *J. Pharm. Exptl. Therap.* 150:298.
- Porter, L.K., and W.A. O'Deen (1977). Apparatus for preparing nitrogen from ammonium chloride for nitrogen-15 determinations. *Anal. Chem.* 49:514.
- Porcellati, G., and P. Preziosi (1954). Biological transformation of isonicotinoyl hydrazide. *Enzymologia* 17:47.
- Reynolds, B.A., and A.A. Thomas (1965). A colorimetric method for the determination of hydrazine and monomethylhydrazine in blood. *Am. Ind. Hygiene Assoc. Jour.* 26:527.
- Ross, P.J., and A.E. Martin (1970). A rapid procedure for preparing gas samples for nitrogen-15 determination. *Analyst* 95:817.
- Turner, R.A. (1947). Reactions of semi carbazones. *J. Amer. Chem. Soc.* 69: 875.