

AD A062259

DDC FILE COPY

18 AFGL TR-78-0039

14 EDL-SRL-78-1

LEVEL A

6 AIRCRAFT-BORNE INFRARED MEASUREMENTS

9 Final rept. 1 Oct 74 - 10 Sep 77

10 Ronald J. Huppi
John H. Schummers

Electro-Dynamics Laboratories (SRL)
Utah State University
Logan, Utah 84322

16 76703
S99QSH

11 1 January 1978

12 62p.

17 16, 1004

DEC 18 1978

15 Final Report
Contract F19628-74-C-0190, W ARPA Order - 2656
Period Covered: 1 Oct 74 to 10 Sep 77

Approved for public release; distribution unlimited.

Partly supported by Defense Advanced Research Projects Agency, ARPA Order 2656, monitored by U.S. Army Missile Command under MIPR A3168E-37-7W02, Subject: Aircraft and Background Infrared Signature Measurements and partly sponsored by the Defense Nuclear Agency under Subtask S99QSHI004, Work Unit 11, entitled: Infrared Phenomenology and Optical Code Development.

AIR FORCE GEOPHYSICS LABORATORY
AIR FORCE SYSTEMS COMMAND
UNITED STATES AIR FORCE
HANSCOM AFB, MASSACHUSETTS 01731

✓ 123 870
78 12 13 001

Handwritten signature

ARPA Order No. 2656
Utah State University
MIPR effective 6 Jan 77
MIPR expiration 28 Feb 78
Reporting Period: Oct 74-Sep 77
Aircraft-borne Infrared Measurements

MIPR A3168Z-37-7W02
Contract No. F19628-74-C-0190
P.I.: Brian P. Sandford/AFGL
Project Scientist: Ronald J. Huppi/USU(SRL) (617)275-8273

Qualified requestors may obtain additional copies from the
Defense Documentation Center. All others should apply to the
National Technical Information Service.

UNCLASSIFIED

SECURITY CLASSIFICATION OF THIS PAGE (When Data Entered)

REPORT DOCUMENTATION PAGE		READ INSTRUCTIONS BEFORE COMPLETING FORM
1. REPORT NUMBER AFGL-TR-78-0039	2. GOVT ACCESSION NO.	3. REPORT'S CATALOG NUMBER EDL-SRL-78-1
4. TITLE (and Subtitle) AIRCRAFT-BORNE INFRARED MEASUREMENTS		5. TYPE OF REPORT & PERIOD COVERED Final Report 1 Oct 74 to 10 Sep 77
		6. PERFORMING ORG. REPORT NUMBER
7. AUTHOR(s) Ronald J. Huppi and John H. Schummers		8. CONTRACT OR GRANT NUMBER(s) F19628-74-C-0190
9. PERFORMING ORGANIZATION NAME AND ADDRESS Utah State Univ. of Agriculture & Applied Sciences, University Hill Logan, Utah 84322		10. PROGRAM ELEMENT, PROJECT, TASK AREA & WORK UNIT NUMBERS 62101F/7670/1101 62704H/CDNA0004 62301E
11. CONTROLLING OFFICE NAME AND ADDRESS Air Force Geophysics Laboratory Hanscom AFB, Mass., 01731 Monitor/Brian P. Sandford/OPR		12. REPORT DATE
		13. NUMBER OF PAGES 63
14. MONITORING AGENCY NAME & ADDRESS (if different from Controlling Office)		15. SECURITY CLASS. (of this report) UNCLASSIFIED
		15a. DECLASSIFICATION/DOWNGRADING SCHEDULE
16. DISTRIBUTION STATEMENT (of this Report) Approved for public release, distribution unlimited.		
17. DISTRIBUTION STATEMENT (of the abstract entered in Block 20, if different from Report)		
18. SUPPLEMENTARY NOTES The views and conclusions contained in this document are those of the authors and should not be interpreted as necessarily representing the official policies either expressed or implied of the Defense Advanced Research Projects Agency. (Continued)		
19. KEY WORDS (Continue on reverse side if necessary and identify by block number) Interferometer, radiometer, infrared measurements, aircraft, platform, aircraft source, aurora, spatial data system. <i>microaster</i>		
20. ABSTRACT (Continue on reverse side if necessary and identify by block number) Infrared measurements of natural and induced infrared sources were measured. The measurements included: near infrared atmospheric measurements in an auroral region with radiometers in the 1.7 μm and 2.8 μm region; infrared measurements of aircraft emissions and reflections in the 2.5 to 7.5 μm spectral region; and spectral measurements of the airglow emissions produced by fundamental hydroxyl chemiluminescent processes in (Continued)		

DD FORM 1 JAN 73 1473 EDITION OF 1 NOV 65 IS OBSOLETE

UNCLASSIFIED

SECURITY CLASSIFICATION OF THIS PAGE (When Data Entered)

78 12 13 001

UNCLASSIFIED

SECURITY CLASSIFICATION OF THIS PAGE(When Data Entered)

Item 18 (Continued)

Partly supported by Defense Advanced Research Projects Agency ARPA Order 2656, monitored by U.S. Army Missile Command under MIPR A3168E-37-7W02, Subject: Aircraft and Background Infrared Signature Measurements and partly sponsored by the Defense Nuclear Agency under Subtask S99QSHI004, Work Unit 11, entitled: Infrared Phenomenology and Optical Code Development.

Item 20 (Continued)

the upper atmosphere. All of the measurements were made from AFGL's NKC-135A S/N 53120 aircraft.

To accomplish the measurements it was necessary to modify, maintain, calibrate, and operate various interferometer and radiometer systems. Processing and reduction of the data were also major efforts which were necessary to allow proper presentation of the measurements in scientific reports. The data reduction techniques were continually improved to efficiently provide the desired graphs and tables. An important advancement was made in the spatial radiometer data reduction process. A system was designed and techniques were developed which enable one to accurately calibrate the spatial data taken with the existing AFGL spatial radiometers. Citations are provided to

The measured data and significant hardware advances have been presented in scientific reports and open literature. References to these reports are given herein.

UNCLASSIFIED

SECURITY CLASSIFICATION OF THIS PAGE(When Data Entered)

TABLE OF CONTENTS

	Page
ACKNOWLEDGEMENTS.....	9
SUMMARY.....	11
NEAR INFRARED MEASUREMENTS IN THE AURORAL REGION.....	12
NIR RADIOMETER MODIFICATION.....	20
RADIOMETER MEASUREMENTS OF AIRCRAFT EMISSIONS AND REFLECTIONS.....	27
SPECTRAL MEASUREMENTS OF FUNDAMENTAL HYDROXYL ATMOSPHERIC EMISSIONS.....	28
MAINTENANCE AND CALIBRATION OF INSTRUMENTATION.....	32
SPATIAL DATA REDUCTION.....	36
SCIENTIFIC REPORTS.....	40
REFERENCES.....	42

SEARCHED	INDEXED	<input checked="" type="checkbox"/>
SERIALIZED	FILED	<input type="checkbox"/>
BY _____		
DISTRIBUTION AVAILABILITY CODES		
GPO	AVAIL. CODE	SPECIAL
A		

RE: AFGL TR-78-0039, Classified references, distribution unlimited
 No change per Capt. Ronald P. Walker,
 AFGL/OPR

LIST OF FIGURES

		Page
Figure 1.	Liquid nitrogen cooled chopper and radiometer system.....	13
Figure 2.	Measurements made with aircraft-borne instrumentation on March 7, 1976 showing significant infrared enhancements which are correlated with aurora.....	16
Figure 3.	Measured data for March 7, 1976 plotted on an expanded time scale to show the correlation between the 2.94 μm emissions and the 3914A emissions during a period when small enhancements occurred.....	17
Figure 4.	Measured data for March 7, 1976 plotted on an expanded time scale to show the excellent spatial and time correlation between the 3914A emissions and the 2.94 μm emissions during rapidly fluctuating auroral conditions.....	18
Figure 5.	Measured data for March 7, 1976 plotted on an expanded time scale to illustrate the correlation between the 3914A emissions and the 2.94 μm emissions during a period when a large enhancement occurred.....	19
Figure 6.	Pictorial of the head assembly of the modified radiometer.....	21
Figure 7.	Infrared viewer used for aiming the four channel radiometer.....	22
Figure 8.	Optical and electrical layout of the four channel radiometer.....	24
Figure 9.	Liquid nitrogen cooled chopper and interferometer system.....	29
Figure 10.	Fundamental hydroxyl spectrum measured on March 26, 1976 from the AFGL NKC-135 aircraft.....	30
Figure 11.	Comparison of measured hydroxyl spectrum with a synthetic spectrum.....	31

LIST OF FIGURES (Cont'd)

	Page
Figure 12. Calibration set up for the liquid nitrogen cooled chopper-collimator.....	34

LIST OF TABLES

	Page
Table 1. Instrument specifications for 1975 and 1976 ICECAP airborne measurements.....	15
Table 2. Probeye infrared viewer specifications.....	23
Table 3. Summary of the four channel radiometer specifications.....	26
Table 4. Optical transmission of the liquid N ₂ chopper system with Ca ₂ F ₁ and GE-106 ² windows for various fields of view of a radiometer.....	35

ACKNOWLEDGEMENTS

The Defense Nuclear Agency and Defense Advanced Research Projects Agency sponsored the research covered by this contract. The efforts were defined and monitored by AFGL. The continued support of these agencies was greatly appreciated.

Several employees of the Electro-Dynamics Laboratories (EDL) were instrumental in the completion of the contractual efforts. Supervision of the efforts was performed by Ronald J. Huppi and Doran J. Baker. Engineering and field measurement support were provided by Randy B. Shipley, Larry B. Smith, Dr. John H. Schummers, Brent Bartschi, Roy W. Esplin and Ronald J. Huppi. Thomas Hudson IV provided laboratory technician support. Data reduction and analysis efforts were accomplished by Ronald J. Huppi, John H. Schummers, Gene Ware and Charles Eastman. In addition, the complete EDL team was available for consultation providing great depth for solving the required problems.

The authors would also like to recognize the direction given by Brian P. Sandford and Dr. A.T. Stair of AFGL. Their guidance and interest in the efforts were appreciated.

SUMMARY

Under this contract Utah State University (USU) has planned and performed spectral measurements of natural and induced background and target sources, maintained and improved radiometer and interferometer instrumentation, and performed data reduction and analysis on measured data. Measured data and instrumentation descriptions have been presented in AFGL reports and open literature. This report summarizes the contractual work which was performed and the reports which were written. The applicable reports include three scientific reports (*Huppi and Baker* [1976], *Huppi* [1976], *Huppi and Reed* [1977]) and a series of reports co-authored with AFGL/Optical Physics Division, *Sandford et al.* [1976a, 1976b, 1976c, 1976d, 1977a, 1977b]. The measurements are a continuation of those performed on contract number F19628-73-C-0302 which was previously completed by USU.

The major contractual efforts have been as follows:

1. Near infrared measurements in the auroral region were made with radiometers in the 1.70 μm and 2.8 μm regions.
2. An existing USU radiometer was modified to operate as part of the NIR radiometer system in the aircraft in the 2.0 to 7.5 μm spectral region.
3. Infrared measurements of aircraft emissions and reflections from 2.5 μm to 7.5 μm were made with the four channel NIR radiometer.
4. Interferometric spectral measurements of the hydroxyl fundamental region were made of the atmosphere with the Type III interferometer system.
5. Periodic calibrations and inspections were made of the radiometers and the interferometer systems.

6. A data reduction system was designed for the AFGL spatial radiometers.

7. Scientific reports and open literature reports were written and published.

NEAR INFRARED MEASUREMENTS IN THE AURORAL REGION

Significant infrared emission enhancements in the 2.75 to 3.04 μm region were measured from the AFGL NKC 135A aircraft while viewing an aurorally excited atmosphere with a radiometer. The measured enhancements occurred while viewing all types of auroral forms during the 1975 and 1976 ICECAP measurement program, and they became significant with respect to the night sky background emissions whenever the N_2^+ emissions at 3914A exceeded about 20 kiloRayleighs.

The 2.75 to 3.04 μm measurements were made with the Type III interferometer-radiometer system. A layout of the instrument system is shown in Figure 1. The system consists of an uncooled radiometer which is operated behind a liquid nitrogen cooled chopper. The cold chopper modulates the incoming atmospheric emissions and provides a cold reference source for the radiometer. As the chopper spins an alternating signal is seen by the radiometer which is due almost entirely to the emissions from the atmosphere. The chopper is mounted outside the aircraft with all the windows and the radiometer components mounted inside. Therefore, the thermal emissions from the window and radiometer components are not chopped and they do not contribute to the alternating signal. Thus, only the atmospheric emissions are detected when the alternating signal of the radiometer is synchronously demodulated using a reference signal from the chopper.

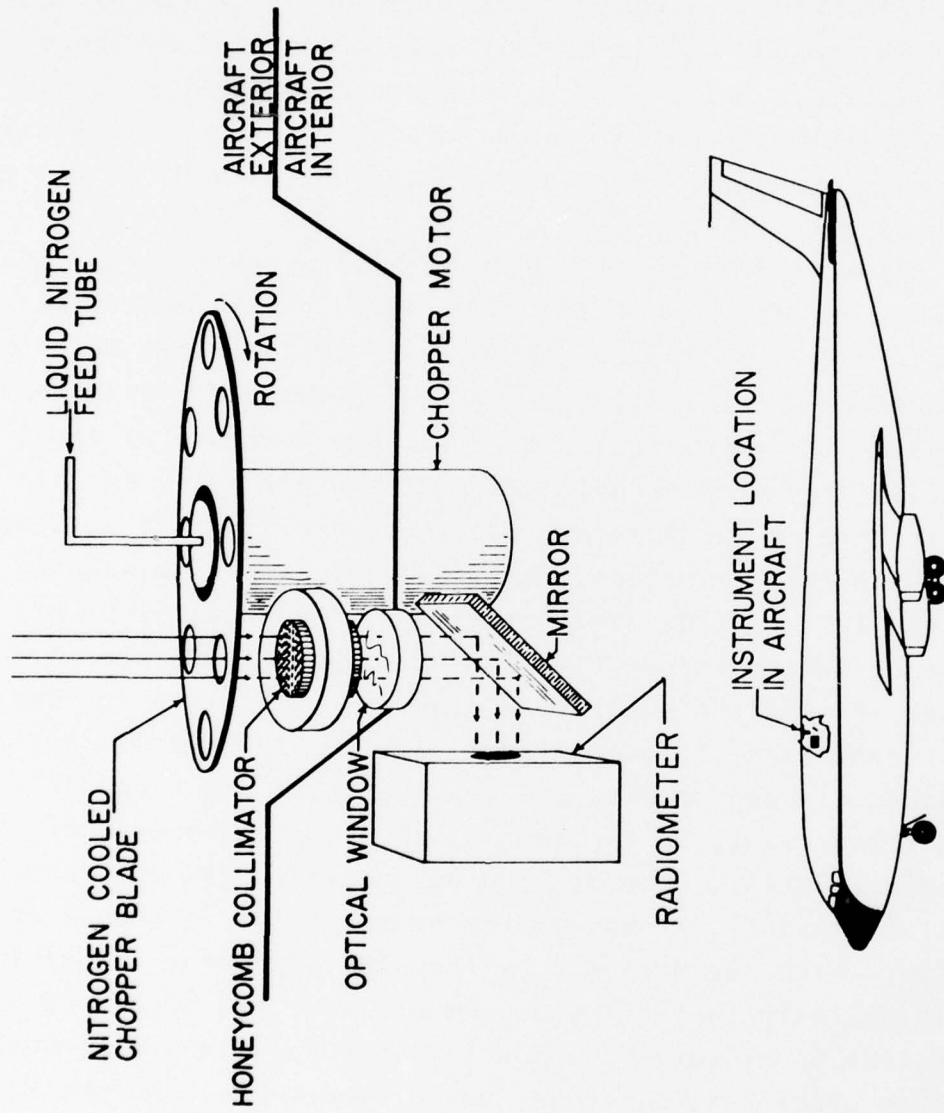

Figure 1. Liquid nitrogen cooled chopper and radiometer system.

In addition to the cold chopper-radiometer system, three other instrument systems were operated to provide additional monitors of the atmospheric conditions. They included the NIR radiometer developed by *Huppi* [1977], a 3914A photometer and an all-sky camera operated by Photometrics, Inc. All of the instruments were co-aligned and looked vertically out of the aircraft with identical fields of view. A summary of the specifications of all the instruments is given in Table 1.

Scientific Report No. 3, which was a contractual effort, presents and analyzes the data measured by the instrumentation, *Huppi and Reed* [1977]. An example of typical data which was measured on March 7, 1976 is shown in Figure 2. From top to bottom the figure gives the latitude location of the aircraft, the longitude location of the aircraft, the air temperature at the aircraft altitude, the aircraft altitude, the 3914A (N_2^+) emissions, the 2.94 μm infrared emissions, and the 1.70 μm (OH, $\Delta V=2$) emissions. Expanded plots of three of the enhancement periods are shown in Figures 3, 4, and 5. Within the angular resolution capabilities of the instrumentation, the measured 2.75 to 3.04 μm (2.94 μm) enhancements appeared to co-vary spatially and temporally with enhancements in the ionization prompt fluorescence of the N_2^+ at 3914A. However, the enhancements did not correlate with the (5,3) band of the hydroxyl $\Delta V=2$ sequence at 1.7 μm , which was measured by the NIR radiometer. Therefore, it is unlikely that the enhancements were the result of increases in hydroxyl fundamental sequences due to perturbed airglow processes, since one would expect the fundamental hydroxyl emissions in the 2.75 to 3.04 μm region to behave similar to the overtone emissions as given by *Baker* [1976]. It is suggested by *Huppi and Reed* [1977] and *Stair et al.* [1975] that first overtone nitric oxide is the most probable source creating the enhanced infrared emissions.

TABLE 1. Instrument specifications for 1975 and 1976 ICE CAP airborne measurements.

Instrument/Year	Field of View (Degrees Circular)	Spectral Response (μm)		Noise Equivalent Radiance*(kiloRayleighs RMS)
		Center λ	$\Delta\lambda$ (50%)	
Type III Radiometer 1975	10	2.83	.155	3.9
1976	10	2.94	.20	6.0
1976	5	2.76	.56	9.0
NIR Radiometer 1975 & 1976	10	1.70	.07	1.0
Photometer 1975	10	.5914	.0014	.007**
1976	10	.5914	.0014	.007**
1976	5	.5914	.0014	.010**
All Sky Camera 1975 & 1976	165	Film	Film	N/A

* Measured for a noise equivalent bandwidth of .05 Hz.

** Noise level is limited by the dark current of the photomultiplier tube.

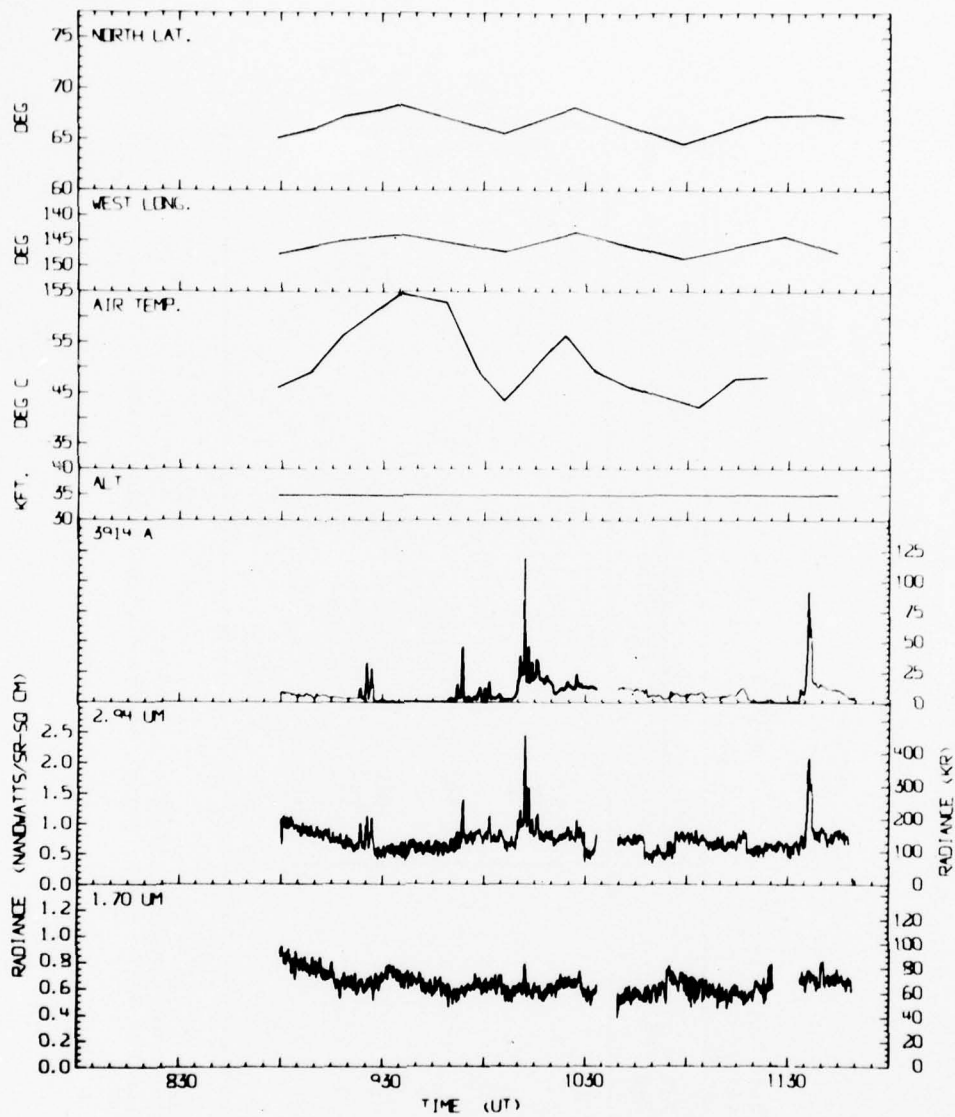

Figure 2. Measurements made with aircraft-borne instrumentation on March 7, 1976 showing significant infrared enhancements which are correlated with aurora.

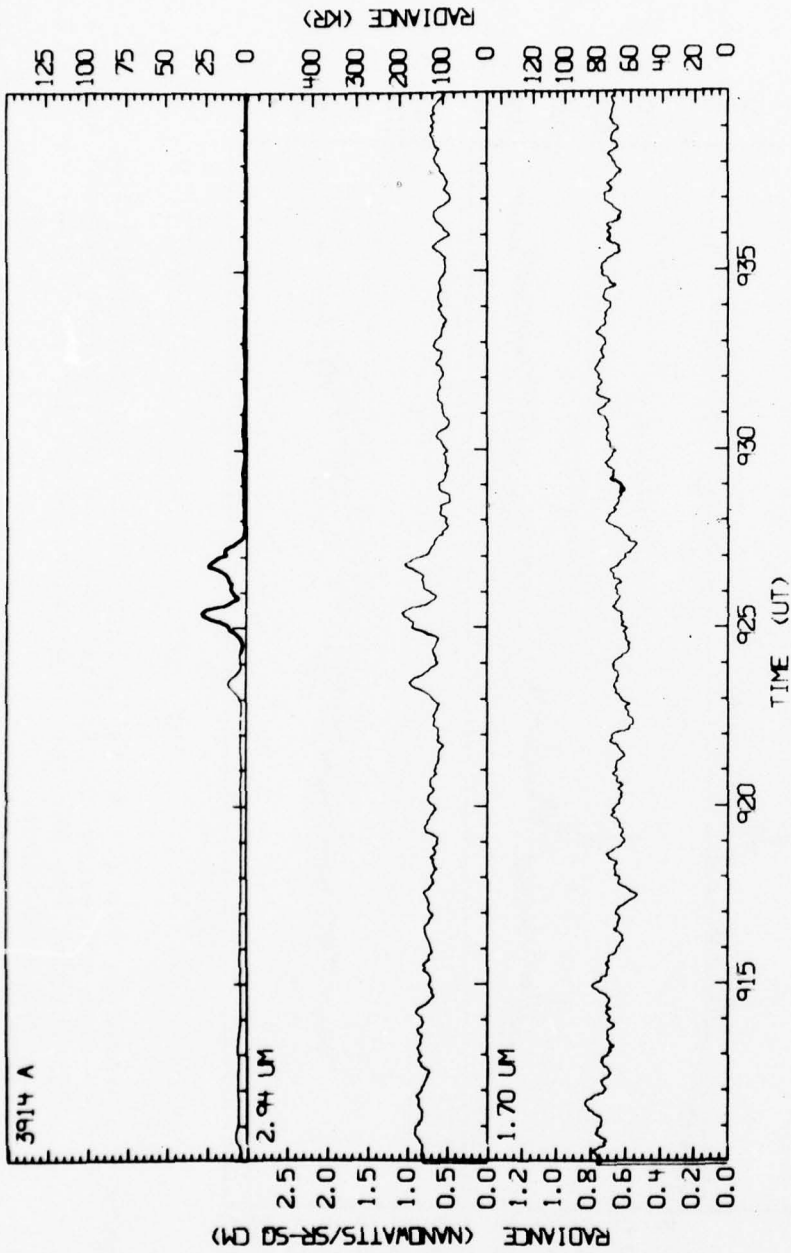

Figure 3. Measured data for March 7, 1976 plotted on an expanded time scale to show the correlation between the 2.94 μm emissions and the 3914A emissions during a period when small enhancements occurred.

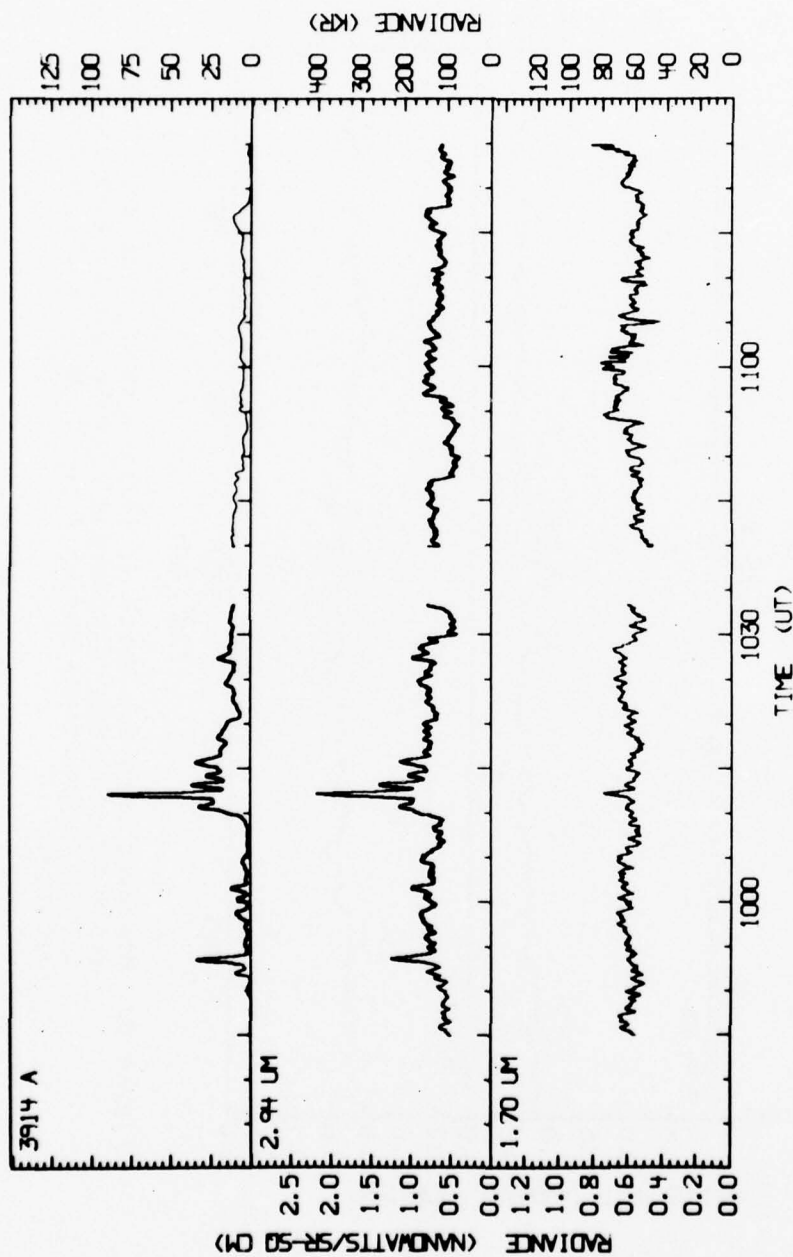

Figure 4. Measured data for March 7, 1976 plotted on an expanded time scale to show the excellent spatial and time correlation between the 3914A emissions and the 2.94 μm emissions during rapidly fluctuating auroral conditions.

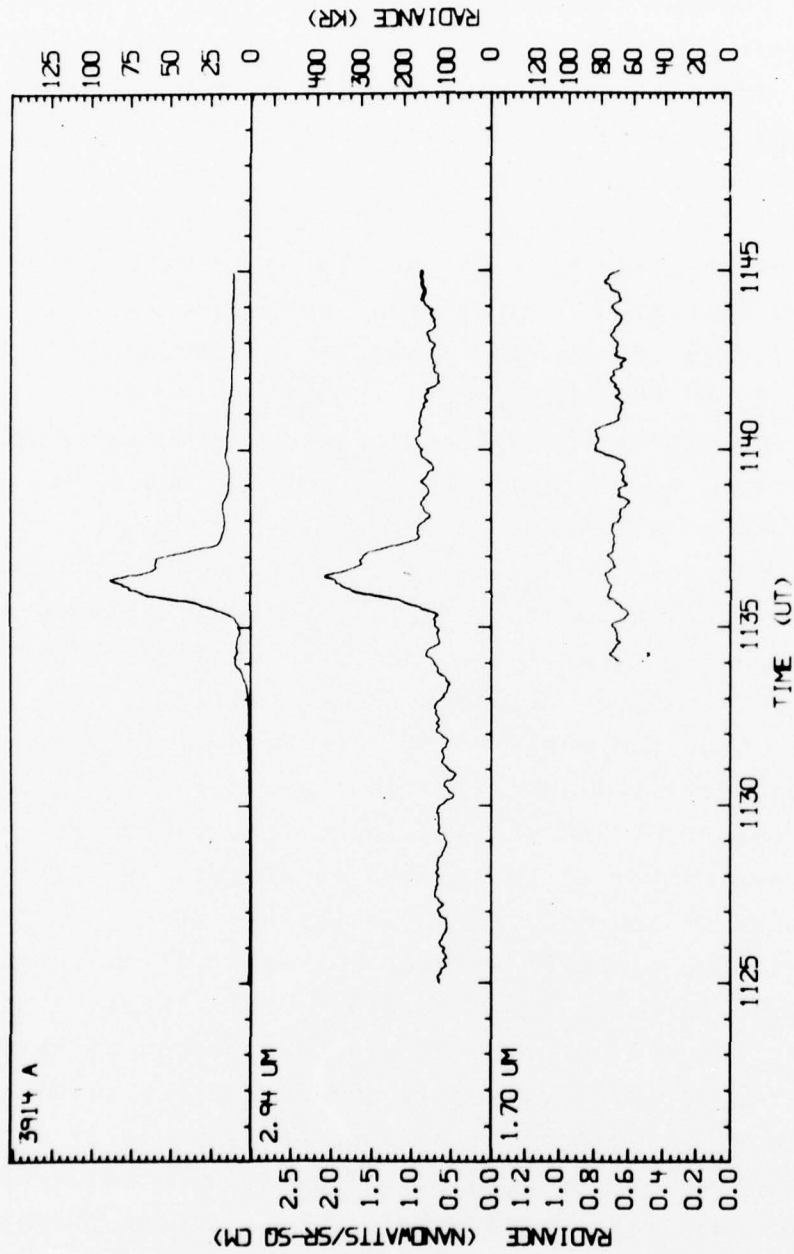

Figure 5. Measured data for March 7, 1976 plotted on an expanded time scale to illustrate the correlation between the 3914A emissions and the 2.94 μm emissions during a period when a large enhancement occurred.

NIR RADIOMETER MODIFICATION

A four channel radiometer, which was constructed using the techniques given in Scientific Report No. 2 by *Huppi* [1976], was modified to operate as part of the NIR aircraft-borne radiometer system. The basic radiometer including optics and electronics was existant in USU's inventory of instruments. In order to apply the radiometer to the Teal Ruby measurement program it was necessary to make modifications to the instrument. Provisions were made to allow spectral coverage from 2.0 to 7.5 μm , to match the instrument fields of view to the measurement requirements, and to allow aiming the instrument through an infrared germanium window.

A pictorial of the head assembly of the modified radiometer is shown in Figure 6. As shown in the figure, an infrared viewer made by Hughes Aircraft Company was mounted to the top of the radiometer. This viewer was co-aligned with the fields of view of the radiometer channels, and it was modified by USU to include an aiming reticle. The optical layout of the modified infrared viewer is shown in Figure 7, and detailed specifications are given in Table 2. The image properties and sensitivity of the viewer allow the radiometer and viewer to be tracked on almost any object or infrared emission source. This is possible even through a germanium window, since the viewer converts infrared images which transmit through germanium, to visible images that can be seen with the eye. During many data missions we have found that the infrared viewer is sufficient for viewing and tracking almost all practical measurement sources of interest.

The main radiometer consists of four independent optical and detector channels, which make use of a common chopper. Figure 8 shows an optical and electrical layout which is representative of each channel. The collecting lens, L_1 ,

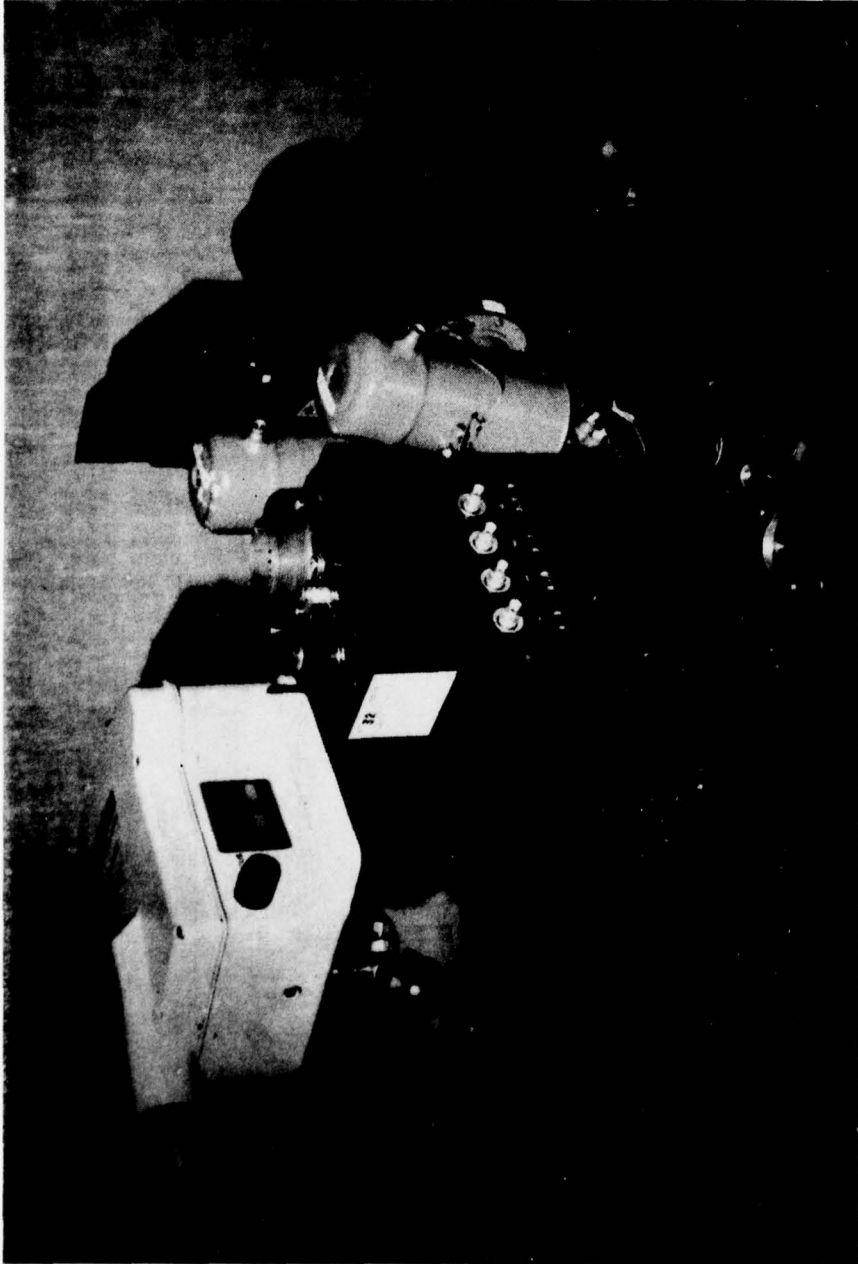

Figure 6. Pictorial of the head assembly of the modified radiometer.

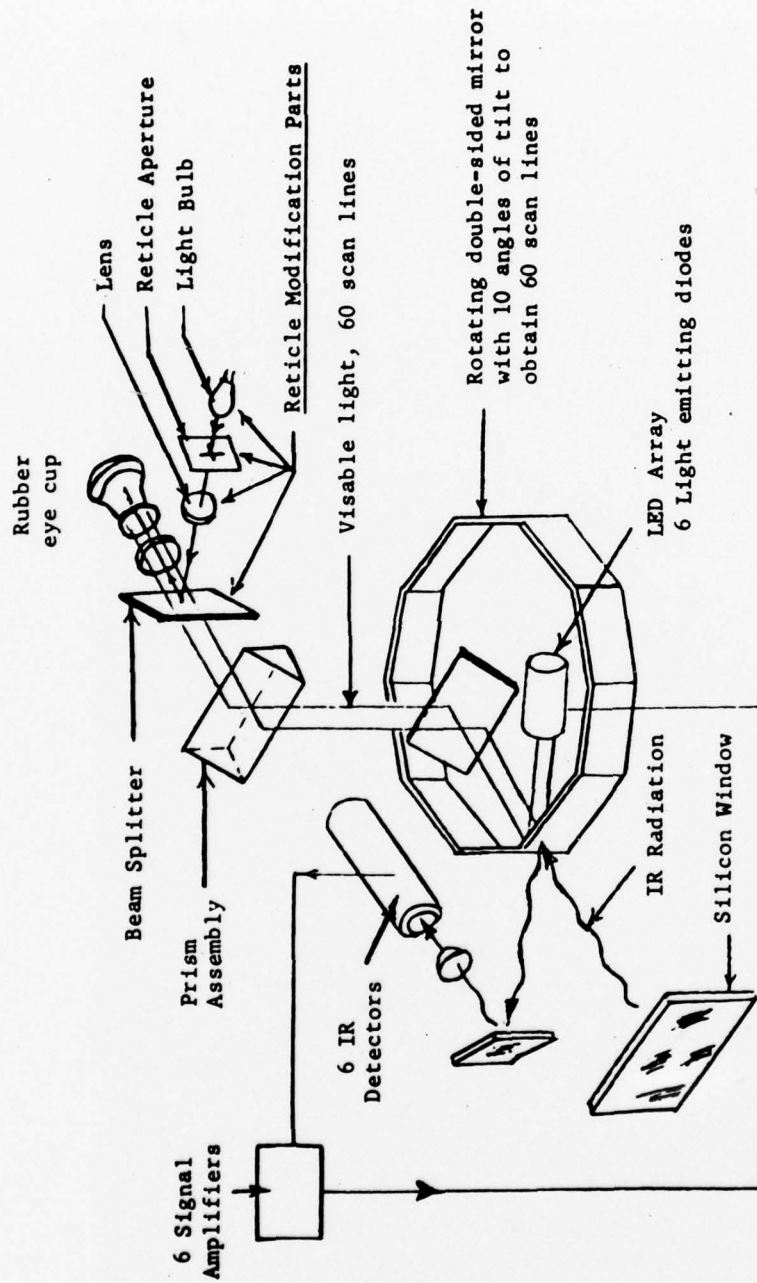
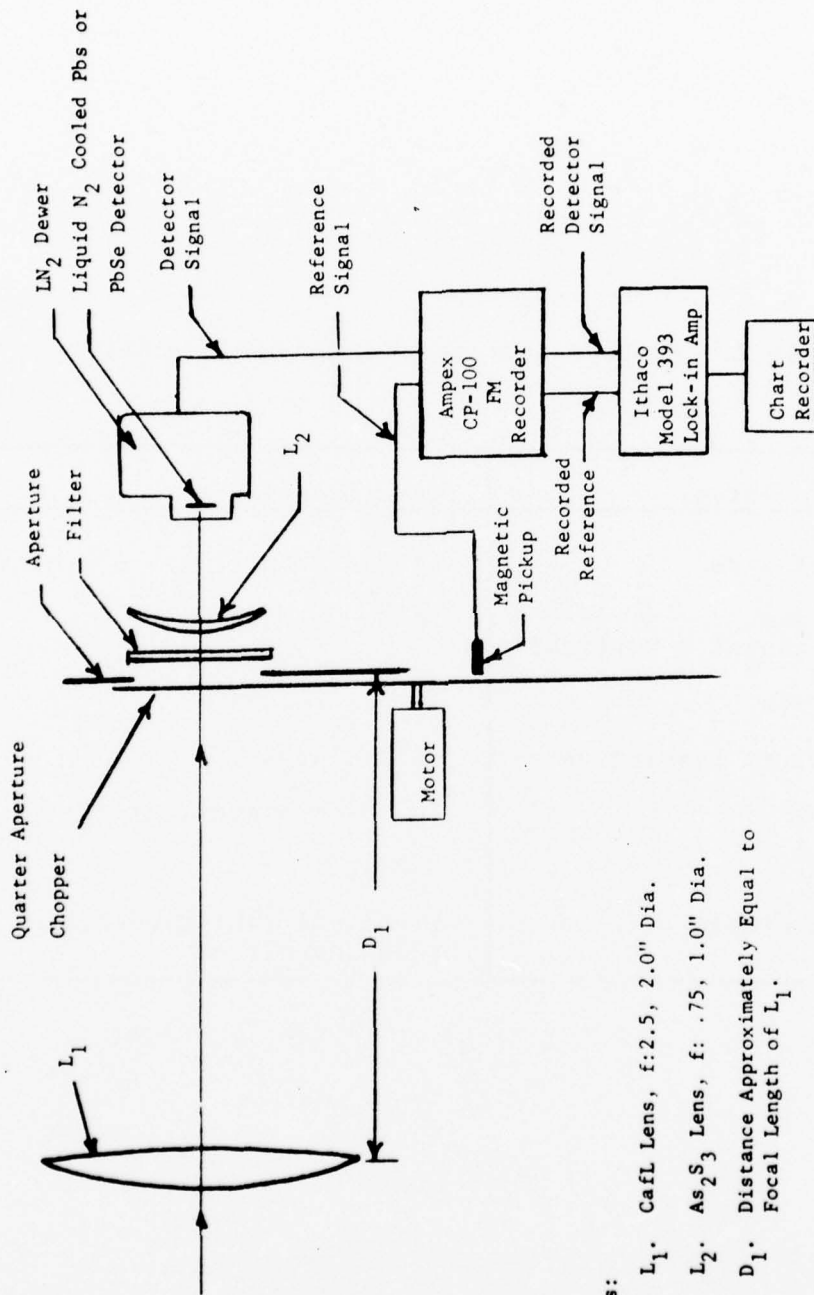

Figure 7. Infrared viewer used for aiming the four channel radiometer.

Table 2. Probeye Infrared Viewer Specifications

Characteristics	Specifications
Field of view	18 ^o horizontal x 7.5 ^o vertical
Resolution (horizontal & vertical)	.12 ^o
Frame rate	15 per second
Temperature resolution	.5 ^o C minimum
Detector	InSb (6 element array)
Weight	7.2 lb.
Viewing display	Light emitting diodes and scanning mirror



Notes:

L_1 . CaF₂ Lens, f:2.5, 2.0" Dia.

L_2 . As₂S₃ Lens, f: .75, 1.0" Dia.

D_1 . Distance Approximately Equal to Focal Length of L_1 .

Figure 8. Optical and electrical layout of the four channel radiometer.

focuses incident radiation on the aperture. The energy that passes through this aperture is optically filtered with a changeable interference filter and is collected by lens, L_2 . Lens, L_2 , then focuses the energy on a liquid nitrogen cooled detector.

Proper selection and integration of detectors into the system was one necessary modification which was made to the existing USU radiometer to facilitate the taking of measurements over the 2.0 to 7.5 μm range. Two PbS detectors were incorporated to cover the 2 to 4 μm region and two PbSe detectors were used to cover the 3.5 to 5 μm and 5 to 7 μm regions. All detectors were cooled to 77^oK. A summary of the instrument specifications using these detectors is given in Table 3.

The fields of view of the various channels of the radiometer were matched to individual measurement requirements. Fields of views ranging from $.5^{\circ} \times .5^{\circ}$ to $2^{\circ} \times 8^{\circ}$ were used at various times. The fields of view are changed by modifying the aperture and chopper in the radiometer. Basically, the maximum field of view of a radiometer channel is defined by the size of the aperture, since sources at infinity are focused on the aperture plane (see Figure 8). The FOV defined by the aperture plate can be divided into smaller FOV's by selecting an optical chopper blade with smaller openings than the opening in the aperture plate. Thus, the chopper efficiently modulates only sources which are imaged in an area smaller than or equal to the selected chopper blade opening. Reticle chopping techniques described by *Huppi* [1976] were used to design and balance the blade and aperture openings such that the detector receives constant unmodulated radiation from the blade and instrument at all times during operation. When operated in this mode, the detector also receives constant and unmodulated signals from uniform sources which fill the complete aperture.

Table 3. Summary of The Four Channel Radiometer Specifications

Channel	Spectral Region Being Used	Detector Type	Detector Temperature	Detector D* (Peak, 350,1) cm x Hz ^{1/2} /watt	Typical Minimum Detectable Irradiance for .1 μ m Spectral Band. Watts/cm ²
1	5 μ m to 7 μ m	Extended PbSe	77 ^o K	1.7 X 10 ¹⁰	1.5 X 10 ⁻¹⁰
2	3.5 μ m to 5 μ m	PbS	77 ^o K	1.7 X 10 ¹⁰	3 X 10 ⁻¹¹
3	2 μ m to 4 μ m	PbS	77 ^o K	1.0 X 10 ¹¹	6.0 X 10 ⁻¹²
4	2 μ m to 4 μ m	PbS	77 ^o K	1.0 X 10 ¹¹	6.0 X 10 ⁻¹²

The minimum detectable signal level is not detector noise limited. The level is dependent on background balance and background subtraction capabilities. The values given are for low background conditions. If the background is more than 5000 times brighter than the values given in the table, the minimum detectable signal will be dependent on the background level.

If the signal is synchronously rectified using a reference signal from the blade, only modulated signals which are synchronized with the chopper will be detected at the output. Thus, unmodulated uniform backgrounds and thermal emissions from the instrument will not be detectable, but small sources which are modulated are detectable even in bright backgrounds. The radiometer operating in this mode has provided excellent time history measurements of the emissions from various small sources for the Teal Ruby measurement program.

RADIOMETER MEASUREMENTS OF AIRCRAFT EMISSIONS AND REFLECTIONS

Infrared emissions generated or reflected from various aircrafts during flight were monitored with the four channel radiometer from the AFGL NKC-135 flying laboratory. Typically twelve selectable spectral bands in the 2.5 to 7.5 μm range were monitored on each aircraft, as defined by *Sandford et al.* [1976a]. Time histories of the irradiances of the aircraft sources were measured for various power increases, power decreases, fixed power settings and aircraft maneuvers. Absolute irradiance numbers were obtained for the various power conditions. Specific radiometric measurements and supporting comparisons with the data from the AFGL interferometer-spectrometer and the thermal spatial scanners has been presented in co-authored reports by *Sandford et al.* [1976c , 1976d, 1977a, 1977b]. To accomplish comparison between the radiometric data and the interferometer spectral data, the spectra were integrated over the passbands of the radiometer. As verified in the reports, the radiometer measurements and interferometer measurements are in good agreement. Due to the classified nature of this data, no sample information is given here.

SPECTRAL MEASUREMENTS OF FUNDAMENTAL HYDROXYL ATMOSPHERIC EMISSIONS

A Michelson interferometer, referred to as the Type III-1, was used in conjunction with the liquid nitrogen cooled chopper system to measure the airglow emissions spectra resulting from chemiluminescent reactions of the fundamental hydroxyl (OH) sequences. Scientific Report No. 1, *Huppi and Baker* [1976], gives detailed information about the temporal and spatial variations of hydroxyl emissions. The measurements that will be reported here add to this study by providing a spectrum of the emissions. The measurements were made from the AFGL NKC-135A aircraft looking overhead.

The basic measurement set up is shown in Figure 9. As described by *Huppi* [1974], the interferometer operates at ambient temperatures inside the aircraft while the chopper acts as a cold reference and provides a method for distinguishing the atmospheric emissions from the thermal emissions of the instrument and aircraft structures. Using this measurement technique, sources with spectral radiances in the range of 10^{-9} to 10^{-8} watts/cm²-ster- μ m can be measured in the 2 to 3.5 μ m region, thus providing a technique for measuring the OH fundamental sequences.

A measured spectrum of a portion of the OH fundamental region is shown in Figure 10. The spectrum was measured March 26, 1976, and was reduced by coadding about 30 minutes of data. The emission levels are relatively small; and therefore the signal to noise ratio is not large. However, a comparison of the measured spectrum with a synthetic hydroxyl model, as shown in Figure 11, makes it apparent that the measured emissions result from fundamental hydroxyl processes. In fact a considerable improvement in signal to

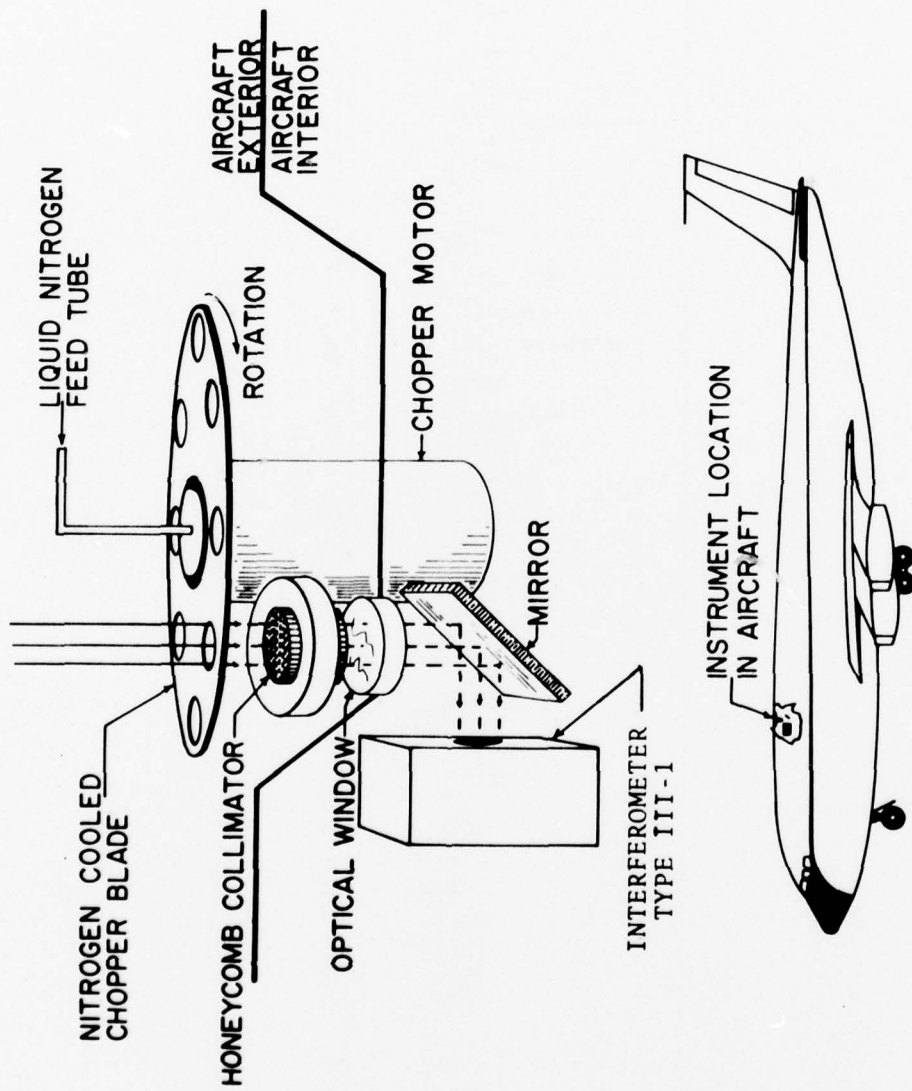

Figure 9. Liquid nitrogen cooled chopper and interferometer system.

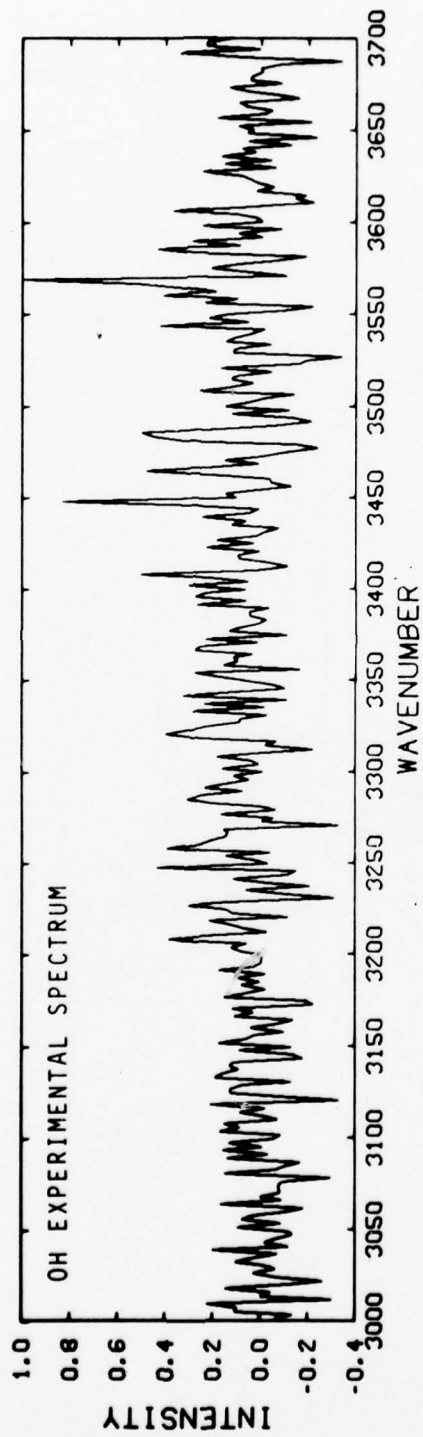

Figure 10. Fundamental hydroxyl spectrum measured on March 26, 1976 from the AFGL NKC-135 aircraft.

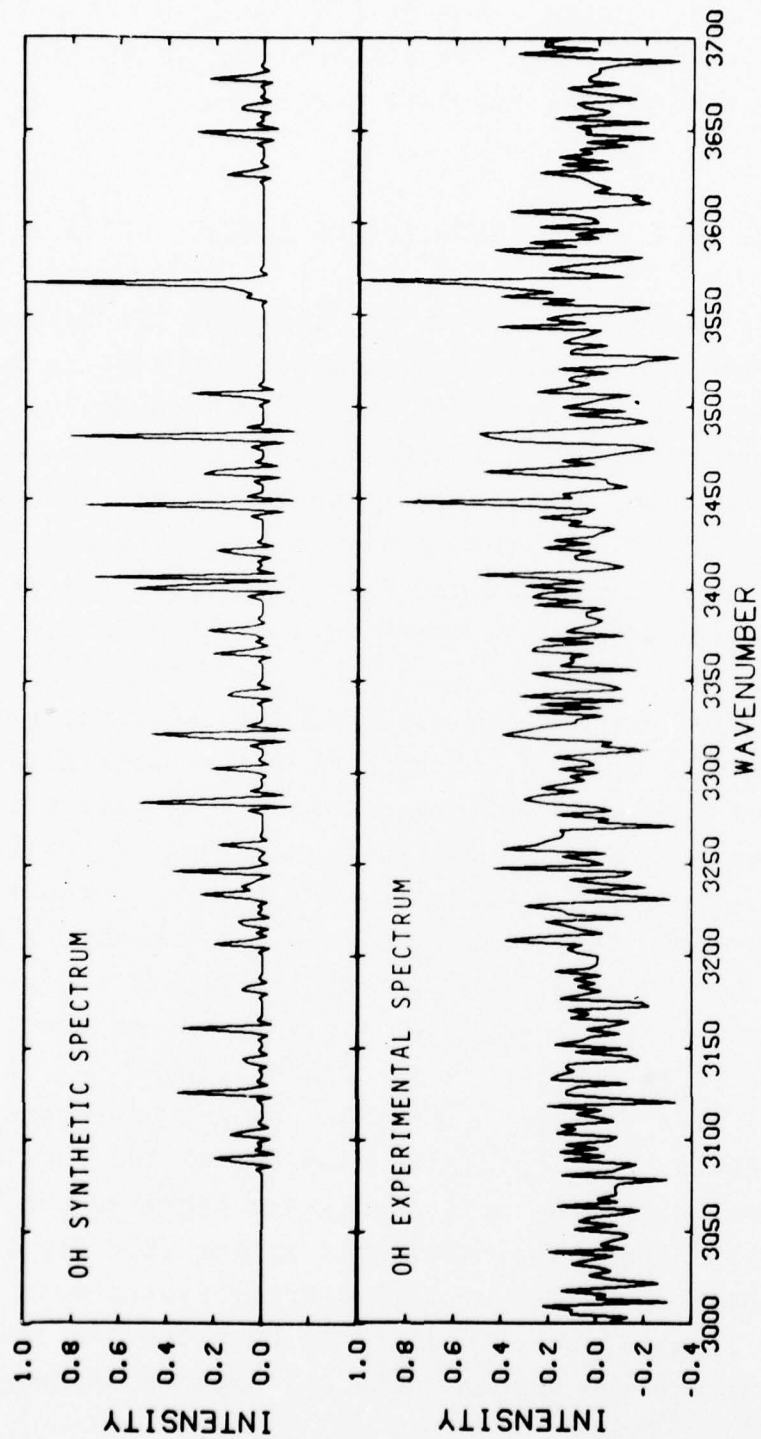

Figure 11. Comparison of measured hydroxyl spectrum with a synthetic spectrum.

noise can be gained through the use of correlation procedures which effectively compare the measured data with a synthetic model. Using a correlation technique *Huppi* [1978] has further verified that the measured emissions did indeed result from fundamental hydroxyl processes.

MAINTENANCE AND CALIBRATION OF INSTRUMENTATION

The NIR radiometer system and the Type III interferometer-radiometer system were maintained and kept in a state of readiness. The optical, electrical and mechanical parts were thoroughly inspected in the laboratory before and after each series of data missions. Inspections were also made during data flights and during each set of data missions. Parts were replaced as needed to insure proper operation of the instruments and to keep them in a constant state of readiness.

In addition to regular maintenance, each instrument was calibrated before and after each set of data missions. Calibrations were also performed on-board the aircraft during flight as necessary. The calibration methods described by *Sandford et al.* [1976a] were used for the radiometers and interferometers. Typically, laboratory calibrations are done using both a point source and an extended source. The inflight calibrations are done with an extended source which can be related to the laboratory calibrations.

In addition to the calibrations of the radiometers and interferometers, the Type III system has an added calibration problem, since the instruments are operated behind a cold optical chopper and collimator system (See Figures 1 and 9). The attenuation of this chopper system must be determined if absolute values are to be placed on data measured through the system. The calibration is complicated

by the fact that the attenuation of the collimator portion varies as a function of angle, and therefore, the throughput will vary when used with instruments having different fields of view.

The best way to calibrate the attenuation effect of the collimator is to perform a measurement using an extended source, the chopper system, and the actual radiometer or interferometer which is to be used. This process was performed for a radiometer for three field of view settings. The calibration set up is shown in Figure 12. As shown, a point source is chopped and sent into an integrating sphere. The sphere converts the point source to an extended source which is then measurable with the radiometer through the chopper system. During this process, the chopper blade is left in the open position. Then the chopper system is removed and the measurement is repeated. The ratio between the first and second measurement gives the integrated attenuation of the collimator and aperture for the specific field of view characteristics of the radiometer. Table 4 summarizes the attenuation of the chopper system for the three fields of views which were measured with the type III radiometer whose entrance aperture is partially vignetted by the chopper aperture. These values give a rough overview of typical attenuations for a practical radiometer with typical fields of view. To complete the calibration of the chopper system, the above results must be multiplied by the chopping efficiency of the rotating chopper. This efficiency can be readily calculated from the geometry of the system. The actual chopper blade modulates the incoming radiation in almost a sinusoidal fashion and has an efficiency of about 40%. This is only slightly less than an optimum square wave chopper which has an efficiency of 50%.

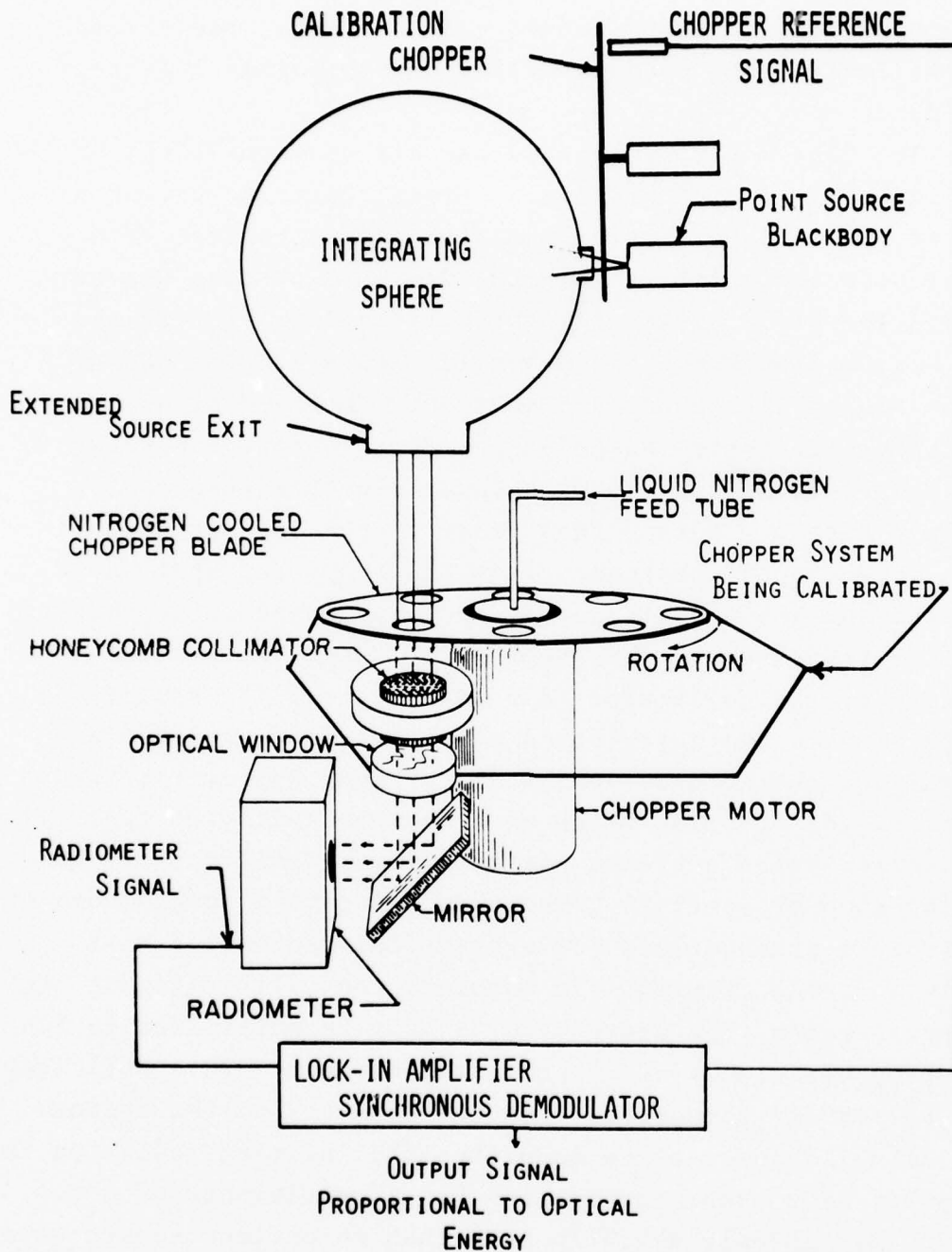

Figure 12. Calibration set up for the liquid nitrogen cooled chopper-collimator.

Table 4. Optical Transmissions of the Liquid N₂ Chopper System with Ca₂F1 and GE-106 Windows for Various Fields of View of Radiometers.

Field of View (Degrees)	Window Type	Measurement Wavelength (μm)	Window & Collimator Transmittance Unchopped (Percent)
10	Ca ₂ F1	2.9	23.5
10	GE-106	2.9	19.1
5	Ca ₂ F1	2.9	51.0
5	GE-106	2.9	28.7
2	Ca ₂ F1	2.9	34.5
2	GE-106	2.9	51.0

SPATIAL DATA REDUCTION

One of the important efforts performed under this contract was the development of a system to quantitatively analyze spatial data that is being acquired by AFGL. Instrument parameters and illustrative data are contained in the reports by *Sandford et al.* [1976a,b,c,d, 1977a,b]. The analysis of the spatial data is valuable since it measures the spatial distribution of the infrared energy produced by a scene being viewed. For many problems, this spatial measurement may be of great importance in determining where the energy measured by spectral or radiometric instruments is distributed in their fields of view. It is also important for determining whether a localized target can be discriminated against various types of backgrounds.

A detailed description of the entire instrument and analysis system will be forthcoming as an AFGL technical report with joint AFGL and SRL authorship. In this section of this report, a brief overview will be given, covering the primary contributions that SRL make to this development program.

Several years ago, AFGL obtained an instrument system potentially capable of making accurate, quantitative measurements of the spatial distribution of infrared energy over a fairly wide field of view. Since this information was of secondary importance to that produced by spectral and temporal radiometers, the only analysis performed on the data was the making of qualitative pictures showing which portions of the field of view were emitting more infrared energy than the other portions. Accurate numeric measurements could not be made since the procedure involved making Polaroid snapshots of a CRT screen that was displaying the scene as measured by the instrument. The pictures did not contain

any reference measurements so that effective brightness could be compared to that produced by known radiance levels. Thus large changes in radiance levels from picture to picture were difficult to determine.

As the measurement programs at AFGL evolved, the spatial measurements greatly increased in importance. It became obvious that analysis procedures, and equipment to implement these procedures, were needed. Equipment was purchased by AFGL containing the necessary computing power, storage capacity, digital input and output, and graphic and pictorial display devices. Although this equipment was purchased by AFGL, a great deal of consultation with SRL personnel was performed to insure that all necessary equipment was available without raising the cost unnecessarily.

Once the equipment was obtained, the large task of designing and implementing the necessary procedures for accurate analysis of the spatial data had to be performed. As in the procurement of the data analysis equipment, the basic software was written by AFGL, but the procedures to be implemented, and the techniques to implement them, were determined largely through interaction and consultation with SRL.

The basic procedures for analyzing the spatial data are described in the following paragraphs. The first step is to determine basically what scene was being viewed as a function of time and which bandpass filters were used during a data collective run. This is done by monitoring various housekeeping functions and voice channels. Once the intervals of time to be analyzed have been determined, the computer can be commanded to digitize several infrared pictures and store them on a digital disc memory. Once a large number of pictures have been digitized, they are displayed on the pictorial display device. By careful examination of

each digitized picture, individual pictures can be selected for further processing, or in cases where the scene is stationary for several pictures, the pictures can be averaged for better signal to noise levels and then further processed.

The next step is to eliminate, as much as possible, any distortions introduced by the measurement system. The most important distortions introduced into the data are caused by the ac coupling of each detector in the instrument before the detectors are multiplexed together to form the analog video signal. This ac coupling was introduced to reduce the large amount of low frequency noise produced by the detectors, but it also eliminates the low frequency structure in the pictures. In the most general situation, the low frequencies cannot be re-inserted into the data; but under many circumstances, the appropriate low frequency signals can be assumed known, and higher frequencies boosted to compensate for the attenuation by the instrument. Other types of distortions can also be reduced. Since each detector is ac coupled independently the average level can shift due to differences in the scene from detector to detector. If however, all detectors see the same radiance during some part of the picture, they can be forced to agree in that region and thereby reduce the offsets in average level between detectors. If large noise spikes occur in certain spots, the picture can be filtered in small regions to eliminate or reduce the noise.

The remaining major procedures to be implemented are calibration and display. Once the response of each detector is known for each bandpass filter that was used, calibration of the data frame is reasonably straight forward. One difficulty arises when the filter passband is not flat and the spectral distribution of energy across the band is not uniform. The programs were written to allow the spectral

calibration to be used with an input spectral energy distribution, but in most cases neither is known accurately. In these cases, appropriate assumptions have to be made.

One of the most difficult problems encountered was to obtain calibrations of the detectors that were repeatable and stable with time. Many erroneous calibrations were performed due to high background levels that were not subtracted out, measurement procedures that were inadequate, or calibration signals that were not the necessary size and shape. These problems have been sorted out and accurate calibrations can now be made.

The last step to be discussed concerns storage and display of the corrected and calibrated pictures. Storage is important since many pictures are analyzed and comparisons between many pictures are desired. The storage problem was solved by giving each file a name that described its type, i.e., data or calibration, the bandpass filter used, and the time of measurement, and then storing it on the disc file storage area. Each picture can then be recovered, further processed or displayed at any time. An adequate display of the final results is a critical part of the analysis as well, since a proper type of display is necessary to pass the information on to the user. Calibrated pictorial display, contour plotting and perspective plotting are some of the display means currently available.

SCIENTIFIC REPORTS

The measured data and the data reduction performed under this contract led or contributed to reports. The reports are published as AFGL scientific reports or in the open literature. Three scientific reports were contractually required; however, as requested in the contract, additional reports and articles were written on the contractual efforts. The following is a detailed list of the publications:

Baker, Doran, William Pendleton, Jr., Allan Steed, Ronald Huppi and A.T. Stair, Jr., "Near-Infrared Spectrum of an Aurora," *Journal of Geophysical Research*, Vol.82, No. 10, pp. 1601-1609, April 1, 1977.

Huppi, Ronald J., *Radiometric Instrumentation and Techniques for Measuring Infrared Emissions from the Atmosphere and Targets*, USAF Report No. AFGL-TR-76-0253, Scientific Report No. 2, Contract No. F19628-74-C-0190, Electrodynamics Laboratories, Utah State University, Logan, Utah; October 29, 1976.

Huppi, Ronald J., "Aircraft Borne Measurements, HAES Data Review" AFGL-OP-TM-05, Falmouth, Mass., Proceedings, Vol. 1 Air Force Geophysics Laboratory, Hanscom Air Force Base, Mass., 13-15 June 1977.

Huppi, Ronald J., "A Versatile Radiometer for Infrared Emission Measurements of the Atmosphere and Targets", *J. Soc. Photo-Optical Instr. Engrs.*, Sep/Oct 1977, p. 485.

Huppi, Ronald J., and Doran J. Baker, "Intensity Variations of Atmospheric Hydroxyl Emissions," Scientific Report No. 1, Contract F19628-74-C-0190, USAF AFCRL-TR-75-0032, Air Force Geophysics Laboratory, Hanscom AFB, MA., January 1, 1976.

Sandford, Brian P., John H. Schummers, John D. Rex, Jack Shumsky, Ronald J. Huppi, Randall B. Sluder, "(U) Aircraft Signatures in the Infrared 1.2 to 5.5 Micron

Region," Volume I-- Instrumentation, AFGL-TR-76-0133[I], Hanscom Air Force Base, Mass., 28 June 1976.

Sandford, Brian P., John H. Schummers, John D. Rex, Jack Shumsky, Ronald J. Huppi, Randall B. Sluder, "(U) Aircraft Signatures in the Infrared 1.2 to 5.5 Micron Region", Volume II--Background Measurements, AFGL-TR-76-0133 [II], Hanscom Air Force Base, Mass., 28 June 1976.

Sandford, Brian P., John H. Schummers, John D. Rex, Jack Shumsky, Ronald J. Huppi, Randall B. Sluder, "(U) Aircraft Signatures in the Infrared 1.2 to 5.5 Micron Region," Volume III--Aircraft Measurements, Secret, AFGL-TR-76-0133 [III], Hanscom Air Force Base, Mass., 28 June 1976.

Sandford, Brian P., John H. Schummers, John D. Rex, Jack Shumsky, Ronald J. Huppi, Randall B. Sluder, "(U) Aircraft Signatures in the Infrared 1.2 to 5.5 Micron Region," Volume IV--Aircraft Data Packs for C135, C9A, C141A and F111E, Secret, AFGL-TR-76-0133 [IV], Hanscom Air Force Base, Mass., 28 June 1976.

Sandford, Brian P., Ronald P. Walker, Capt., USAF, John D. Rex, Jack Shumsky, John K. Little, 1Lt USAF, John H. Schummers, Ronald J. Huppi and Randall B. Sluder, "(U) Aircraft Signatures in the Infrared 1.2 to 5.5 Micron Region", Volume V--Aircraft Data Packs for C5A, E4A, B52G, B52H and A7D, Secret, AFGL-TR-77-0138, Hanscom AFB, Mass., 22 June 1977.

Sandford, Brian P., John H. Schummers, John D. Rex, Jack Shumsky, John W. Reed, Major, USAF, Ronald J. Huppi and Randall B. Sluder, "(U) Infrared Signatures of T38A Aircraft in the 1.7 to 7.5 Micron Region", Confidential, AFGL-TR-77-0156, Hanscom AFB, MA., 15 July 1977.

Huppi, R.J., and J.W. Reed, Jr., "Aircraftborne Measurements of Infrared Enhancements During ICECAP 1975 and 1976", AFGL-TR-77-0232, HAES Report #68, Hanscom AFB, Mass., Scientific Report #3, AF 19628-74-C-0190.

REFERENCES

Baker, D.J. [1976], "The Upper-Atmospheric Hydroxyl Airglow," Manuscript, Air Force Geophysics Laboratory, Hanscom AFB, Mass., and Utah State University, Logan, Utah, May 1976, p. 23.

Huppi, E.R. [1978], private communication regarding correlation techniques for increasing the signal to noise of a spectrum.

Huppi, Ronald J., and Doran J. Baker, "Intensity Variations of Atmospheric Hydroxyl Emissions," Scientific Report No. 1, Contract F19628-74-C-0190, USAF AFCRL-TR-75-0032, Air Force Geophysics Laboratory, Hanscom AFB, MA., January 1, 1976.

Huppi, E.R., Rogers, J.W., and Stair, A.T., Jr. [1974] "Aircraft Observations of the Infrared Emission of the Atmosphere in the 700-2800 cm^{-1} Region", Applied Optics, Vol. 13, No. 6, June 1974, p. 1466.

Huppi, R.J. [1977] "A Versatile Radiometer for Infrared Emission Measurements of the Atmosphere and Targets", Op. Engrg. Vol. 16, No.5, October 1977, p. 485.

Huppi, R.J. [1976] "Radiometric Instrumentation and Techniques for Measuring Infrared Emissions from the Atmosphere and Targets," USAF Report No. AFGL-TR-76-0253, Scientific Report No. 2, Contract No. F19628-74-C-0190, Electro-Dynamics Laboratories, Utah State University, Logan, Utah; October 29, 1976.

Huppi, R.J. and Reed, J.W., Jr. [1977] "Aircraftborne Measurements of Infrared Enhancements During ICECAP 1975 and 1976", AFGL-TR-77-0232, HAES Report #68, Hanscom AFB, Mass., Scientific Report #3, AF 19628-74-C-0190.

Sandford, Brian P., John H. Schummers, John D. Rex, Jack Shumsky, Ronald J. Huppi, Randall B. Sluder, [1976a]

"(U) Aircraft Signatures in the Infrared 1.2 to 5.5 Micron Region," Volume I--Instrumentation, AFGL-TR-76-0133[I], Hanscom Air Force Base, Mass., 28 June 1976.

Sandford, Brian P., John H. Schummers, John D. Rex, Jack Shumsky, Ronald J. Huppi, Randall B. Sluder, [1976b], "(U) Aircraft Signatures in the Infrared 1.2 to 5.5 Micron Region", Volume II--Background Measurements, AFGL-TR-76-0133 [II], Hanscom Air Force Base, Mass., 28 Jun 76.

Sandford, Brian P., John H. Schummers, John D. Rex, Jack Shumsky, Ronald J. Huppi, Randall B. Sluder, [1976c], "(U) Aircraft Signatures in the Infrared 1.2 to 5.5 Micron Region", Volume III--Aircraft Measurements, AFGL-TR-76-0133 [III], Hanscom Air Force Base, Mass., 28 June 1976. (Secret)

Sandford, Brian P., John H. Schummers, John D. Rex, Jack Shumsky, Ronald J. Huppi, Randall B. Sluder [1976d], "(U) Aircraft Signatures in the Infrared 1.2 to 5.5 Micron Region," Volume IV--Aircraft Data Packs for C135, C9A, C141A, and F111E, AFGL-TR-76-0133 [IV], Hanscom Air Force Base, Mass., 28 June 1976. (Secret)

Sandford, Brian P., Ronald P. Walker, Capt., USAF, John D. Rex, Jack Shumsky, John K. Little, 1Lt. USAF, John H. Schummers, Ronald J. Huppi and Randall B. Sluder, [1977a] "(U) Aircraft Signatures in the Infrared 1.2 to 5.5 Micron Region", Volume V--Aircraft Data Packs for C5A, E4A, B52G, B52H and A7D, Secret, AFGL-TR-77-0138, Hanscom AFB, Mass., 22 June 1977.

Sandford, Brian P., John H. Schummers, John D. Rex, Jack Shumsky, John W. Reed, Major, USAF, Ronald J. Huppi and Randall B. Sluder, [1977b] "(U) Infrared Signatures of T38A Aircraft in the 1.7 to 7.5 Micron Region", Confidential, AFGL-TR-77-0156, Hanscom AFB, MA., 15 June 1977.

Stair, A.T., Jr., J.C. Ulwick, K.D. Baker, D.J. Baker [1975], "Rocketborne Observations of Atmospheric Infrared Emissions in the Auroral Region", *Atmospheres of Earth and the Planets*, D. Reidel Pub. Co., Holland, 1975, p. 335.

DISTRIBUTION LIST

Director
Defense Advanced Rsch Proj Agency
Architect Building
1400 Wilson Blvd.
Arlington, VA 22209
Attn: Lt Col W.A. Whitaker

Director
Defense Advanced Rsch Proj Agency
Architect Building
1400 Wilson Blvd.
Arlington, VA 22209
Attn: Lt. Col. W. Cuneo

Defense Documentation Center
Cameron Station
Alexandria, VA 22314
Attn: TC

Defense Documentation Center
Cameron Station
Alexandria, VA 22314
Attn: TC

Director
Defense Nuclear Agency
Washington, DC 20305
Attn: RAAE Charles A. Blank

Director
Defense Nuclear Agency
Washington, DC 20305
Attn: TITL Tech Library

Director
Defense Nuclear Agency
Washington, DC 20303
Attn: TITL Tech Library

Director
Defense Nuclear Agency
Washington, DC 20305
Attn: RAEV Harold C. Fitz, Jr.

Director
Defense Nuclear Agency
Washington, D.C. 20305
Attn: TISI Archives

Director
Defense Nuclear Agency
Washington, DC 20305
Attn: DDST

Director
Defense Nuclear Agency
Washington, DC 20305
Attn: Major R. Bigoni/RAAE

Director of Defense Research
and Engineering
Department of Defense
Washington, DC 20301
Attn: DD/S&SS (OS)
Daniel Brockway

Director of Defense Research
& Engineering
Department of Defense
Washington, DC 20301
Attn: DD/S&SS
Daniel Brockway

Commander
Field Command
Defense Nuclear Agency
Kirtland AFB, NM 87115
Attn: FCPR

Chief Livermore Division
Field Command DNA
Lawrence Livermore Lab.
P.O. Box 808
Livermore, CA 94550
Attn: FCPRL

Commander/Director
Atmospheric Sciences Laboratory
US Army Electronics Command
White Sands Missile Range,
New Mexico 88002
Attn: H. Ballard (3 copies)

Commander/Director
Atmospheric Sciences Laboratory
US Army Electronics Command
White Sands Missile Range,
New Mexico 88002
Attn: DRSEL-BL-SY-A F. Niles
(3 copies)

Commander
Harry Diamond Laboratories
2800 Powder Mill Road
Adelphi, MD 20783
Attn: DRXDO-NP, F.H. Wiminetz

Commander
US Army Nuclear Agency
Fort Bliss, TX 79916
Attn: MONA-WE

Director
BMD Advanced Tech Center
Huntsville, AL 35808
Attn: ATC-T, M. Capps

Director
BMD Advanced Tech Center
Huntsville, AL 35807
Attn: ATC00, W. Davies

Dep.Chief of Staff for Rsch,
DEV & ACO
Department of the Army
Washington, DC 20310
Attn: MBC Division

Dep.Chief of Staff for Rsch,
DEV & ACO
Department of the Army
Washington, DC 20310
Attn: DAMA-CSZ-0

Dep.Chief of Staff for Rsch
DEV & ACO
Department of the Army
Washington, DC 20310
Attn: DAMA-WSZC

Director
US Army Ballistic Research Lab
Aberdeen Proving Grounds
Maryland 21005
Attn: DRXBR-AM G. Keller

Director
US Army Ballistic Research Lab
Aberdeen Proving Grounds
Maryland 21005
Attn: DRXRD-BSP J. Heimerl

Director
US Army Ballistic Research Lab
Aberdeen Proving Grounds
Maryland, 21005
Attn: John Mester

Director
US Army Ballistic Research Lab
Aberdeen Proving Grounds
Maryland, 21005
Attn: Tech Library

Commander
US Army Electronics Command
Fort Monmouth, NJ 37703
Attn: Inst for Expl Research

Commander
US Army Electronics Command
Fort Monmouth, NJ 37703
Attn: DRSEL (5 copies)

Commander
US Army Electronics Command
Fort Monmouth, NJ 37703
Attn: Stanley Kronenberger

Commander
US Army Electronics Command
Fort Monmouth, NJ 37703
Attn: Weapons Effects Sec.

Commander
US Army Foreign Sci & Tech Ctr
220 7th Street, NE
Charlottesville, VA 22901
Attn: Robert Jones

Chief
US Army Research Office
P.O. Box 12211
Triangle Park, NC 27709
Attn: Robert Mace

Commander
Naval Oceans Systems Center
San Diego, CA 92152
Attn: Code 2200 I. Rothmuller

Commander
Naval Oceans Systems Center
San Diego, CA 92152
Attn: Code 2200 W. Moler

Commander
Naval Oceans Systems Center
San Diego, CA 92152
Attn: Code 2200 H. Hughes

Commander
Naval Oceans Systems Center
San Diego, CA 92152
Attn: Code 2200 R. Pappert

Commander
Naval Oceans Systems Center
San Diego, CA 92152
Attn: Code 2200 J.R. Richter

Director
Naval Research Laboratory
Washington, DC 20375
Attn: Code 7712 D.P. McNutt

Director
Naval Research Laboratory
Washington, DC 20375
Attn: Code 7701 Jack D. Brown

Director
Naval Research Laboratory
Washington, DC 20375
Attn: Code 2600 Tech Lib.

Director
Naval Research Laboratory
Washington, DC 20375
Attn: Code 7127 C.Y. Johnson

Director
Naval Research Laboratory
Washington, DC 20375
Attn: Code 7700 T.P. Coffey

Director
Naval Research Laboratory
Washington, DC 20375
Attn: Code 7709 Wahab Ali

Director
Naval Research Laboratory
Washington, DC 20375
Attn: Code 7750 D.F. Strobel

Director
Naval Research Laboratory
Washington, DC 20375
Attn: Code 7750 P. Julienne

Director
Naval Research Laboratory
Washington, DC 20375
Attn: Code 7750 J. Fedder

Director
Naval Research Laboratory
Washington, DC 20375
Attn: Code 7750 S. Ossakow

Director
Naval Research Laboratory
Washington, DC 20375
Attn: Code 7750 J. Davis

Superintendent
Naval Post Graduate School
Monterey, CA 93940
Attn: Tech Reports Librarian

Commander
Naval Surface Weapons Center
White Oak, Silver Spring, MD 20910
Attn: Code WA501 Navy Nuc Prgms

Commander
Naval Surface Weapons Center
White Oaks, Silver Spring MD 20910
Attn: Technical Library

Commander
Naval Intelligence Support Center
4301 Suitland Rd. Bldg 5
Washington, DC 20390
Attn: Document Control

AF Geophysics Laboratory, AFSC
Hanscom AFB, MA 01731
Attn: LKB Kenneth S W Champion

AF Geophysics Laboratory, AFSC
Hanscom AFB, MA 01731
Attn: OPR Alva T. Stair
(5 copies)

AF Geophysics Laboratory, AFSC
Hanscom AFB, MA 01731
Attn: Opr J. Ulwick

AF Geophysics Laboratory, AFSC
Hanscom AFB, MA 01731
Attn: OPR R. Murphy

AF Geophysics Laboratory, AFSC
Hanscom AFB, MA 01731
Attn: OPR J. Kennealy

AF Geophysics Laboratory, AFSC
Hanscom AFB, MA 01731
Attn: PHG J.C. McClay

AF Geophysics Laboratory, AFSC
Hanscom AFB, MA 01731
Attn: LKD Rosco Narcisi

AF Geophysics Laboratory, AFSC
Hanscom AFB, MA 01731
Attn: LKO R. Huffman

AF Weapons Laboratory, AFSC
Kirtland AFB, NM 87117
Attn: Maj G. Ganong, DYM

Commander
ASD
WPAFB, OH 45433
Attn: ASD-YH-EX
Lt Col Robert Leverette

SAMSO/AW
P.O. Box 92960
Worldway Postal Center
Los Angeles, CA 90009
Attn: SZJ Major L. Doan

SAMSO/SW
P.O. Box 92960
Worldway Postal Center
Los Angeles, CA 90009
Attn: AW

AFTAC
Patric AFB, FL 32925
Attn: Tech Library

AFTAC
Patric AFB, FL 32925
Attn: TD

HQ Air Force Systems Command
Andrews AFB
Washington, DC 20331
Attn: DLS

HQ Air Force Systems Command
Andrews AFB
Washington, DC 20331
Attn: Tech Library

HQ Air Force Systems Command
Andrews AFB
Washington, DC 20331
Attn: OLCAE

HQ Air Force Systems Command
Andrews AFB
Washington, DC 20331
Attn: DLTW

HQ Air Force Systems Command
Andrews AFB
Washington, DC 20331
Attn: DLXP

HQ Air Force Systems Command
Andrews AFB
Washington, DC 20331
Attn: SDR

HQ USAF/RD
Washington, DC 20330
Attn: RDQ

Commander
Rome Air Development Center
Griffiss AFB, NY 13440
Attn: J.J. Simons OCSC

Div. of Military Application
US Energy Rsch & Dev Admin
Washington, DC 20545
Attn: DOC CON

Los Alamos Scientific Lab
P.O. Box 1663
Los Alamos, NM 87545
Attn: DOC CON R.A. Jeffries

Los Alamos Scientific Lab
P.O. Box 1663
Los Alamos, NM 87545
Attn: DOC CON CR Mehl ORG 5230

Los Alamos Scientific Lab
P.O. Box 1663
Los Alamos, NM 87545
Attn: DOC CON H.V. Argo

Los Alamos Scientific Lab
P.O. Box 1663
Los Alamos, NM 87545
Attn: DOC CON M. Tierney J-10

Los Alamos Scientific Lab
P.O. Box 1663
Los Alamos, NM 87545
Attn: DOC CON Robert Brownlee

Los Alamos Scientific Lab
P.O. Box 1663
Los Alamos, NM 87545
Attn: DOC CON Wm Maier

Los Alamos Scientific Lab
P.O. Box 1663
Los Alamos, NM 87545
Attn: DOC CON John Zinn

Los Alamos Scientific Lab
P.O. Box 1663
Los Alamos, NM 87545
Attn: DOC CON Reference Lib.
Ann Beyer

Sandia Laboratories
Livermore Laboratory
P.O. Box 965
Livermore, CA 94556
Attn: DOC CON T. Cook ORG
8007

Sandia Laboratories
P.O. Box 5800
Albuquerque, NM 87115
Attn: DOC CON
W.D. Brown ORG 1353

Sandia Laboratories
P.O. Box 5800
Albuquerque, NM 87115
Attn: DOC CON
L. Anderson ORG 1247

Sandia Laboratories
P.O. Box 5800
Albuquerque, NM 87115
Attn: DOC CON
Morgan Kramma ORG 5720

Sandia Laboratories
P.O. Box 5800
Albuquerque, NM 87115
Attn: DOC CON
Frank Hudson ORG 1722

NASA
Goddard Space Flight Center
Greenbelt, MD 20771
Attn: J. Siry

NASA
600 Independence Avenue S.W.
Washington, DC 20545
Attn: A. Gessow

NASA
600 Independence Avenue S.W.
Washington, DC 20546
Attn: D.P. Cauffman

NASA
600 Independence Avenue S.W.
Washington, DC 20546
Attn: Lt Col D.R. Hallenbeck
Code SG

NASA
600 Independence Avenue S.W.
Washington, DC 20545
Attn: R. Fellows

NASA
600 Independence Avenue S.W.
Washington, DC 20546
Attn: A. Schardt

NASA
600 Independence Avenue S.W.
Washington, DC 20546
Attn: M. Tepper

NASA
Langley Research Center
Langley Station
Hampton, VA 23365
Attn: C. Schexnayder MS-168

NASA
Ames Research Center
Moffett Field, CA 90435
Attn: N-25404 W. L. Starr

NASA
Ames Research Center
Moffett Field, CA 94035
Attn: N-254-4 R. Whitten

NASA
Ames Research Center
Moffett Field, CA 94035
Attn: N-254-4 I.G. Poppoff

NASA
Ames Research Center
Moffett Field, CA 94035
Attn: N-254-3 N.H. Farlow

NASA
George C. Marshall Space Flt.
Center
Huntsville, AL 35812
Attn: C. R. Balcher

NASA
George C. Marshall Space Flt.
Center
Huntsville, AL 35812
Attn: N. H. Stone

NASA
George C. Marshall Space Flt.
Center
Huntsville, AL 35812
Attn: W. A. Oran

NASA
George C. Marshall Space Flt.
Center
Huntsville, AL 35812
Attn: Code ES22 John Watts

NASA
George C. Marshall Space Flt.
Center
Huntsville, AL 35812
Attn: W. T. Roberts

NASA
George C. Marshall Space Flt.
Center
Huntsville, AL 35812
Attn: R. D. Hudson

NASA
George C. Marshall Space Flt.
Center
Huntsville, AL 35812
Attn: R. Chappell

Sandia Laboratories
P.O. Box 5800
Albuquerque, NM 87115
Attn: DOC CON ORG 3422
Sandia Repts Coll.

Argonne National Laboratory
Records Control
9700 South Cass Avenue
Argonne, IL 60439
Attn: DOC CON D. W. Green

Argonne National Laboratory
Records Control
9700 South Cass Avenue
Argonne, IL 60439
Attn: DOC CON
LIR SVCS RPTS SEC

Argonne National Laboratory
Records Control
9700 South Cass Avenue
Argonne, IL 60439
Attn: DOC CON S. Garelnick

Argonne National Laboratory
Records Control
9700 South Cass Avenue
Argonne, IL 60439
Attn: DOC CON G.T. Reedy

University of California
Lawrence Livermore Laboratory
P.O. Box 808
Livermore, CA 94550
Attn: W.H. Duerwer Gen L-404

University of California
Lawrence Livermore Laboratory
P.O. Box 808
Livermore, CA 94550
Attn: Julius Chang L-71

University of California
Lawrence Livermore Laboratory
P.O. Box 808
Livermore, CA 94550
Attn: G.P. Haugen L-404

University of California
Lawrence Livermore Laboratory
P.O. Box 808
Livermore, CA 94550
Attn: D.J. Wuerales L-142

California, State of
Air Resource Board
9528 Telsia Avenue
Al Monte, CA 91731
Attn: Leo Zafonte

Calif. Institute of Technology
Jet Propulsion Laboratory
4800 Oak Grove Drive
Pasadena, CA 91103
Attn: Joseph A. Jello

US Energy Rsch & Dev Admin
Div. of Headquarters Services
Library Branch G-043
Washington, DC 20545
Attn: DOC CON Class Tech Lib

Department of Transportation
Office of the Secretary
TAD-44. 1, Room 10402-B
400 7th Street S.W.
Washington, DC 20590
Attn: Samuel C. Coroniti

NASA
Goddard Space Flight Center
Greenbelt, MD 20771
Attn: A. C. Aiken

NASA
Goddard Space Flight Center
Greenbelt, MD 20771
Attn: A. Tempkin

NASA
Goddard Space Flight Center
Greenbelt, MD 20771
Attn: A. J. Bauer

NASA
Goddard Space Flight Center
Greenbelt, MD 20771
Attn: Technical Library

Albany Metallurgy Research Ctr.
US Bureau of Mines
P.O. Box 70
Albany, OR 97321
Attn: Eleanor Abshire

Central Intelligence Agency
RD/SI RM 5G48 HQ Building
Washington, DC 20505
Attn: NED/OSI-2G48 HQS

Department of Commerce
National Bureau of Standards
Washington, DC 20234
Attn: Sec Officer James Devoe

Department of Commerce
National Bureau of Standards
Washington, DC 20234
Attn: Sec Officer S. Abramowitz

Department of Commerce
National Bureau of Standards
Washington, DC 20234
Attn: Sec Officer J Cooper

Department of Commerce
National Bureau of Standards
Washington, DC 20234
Attn: Sec Officer G.A. Sinnatt

Department of Commerce
National Bureau of Standards
Washington, DC 20234
Attn: Sec Officer K Kessler

Department of Commerce
National Bureau of Standards
Washington, DC 20234
Attn: Sec Officer M. Krauss

Department of Commerce
National Bureau of Standards
Washington, DC 20234
Attn: Sec Officer L. Gevantman

Nat'l Oceanic & Atmospheric
Administration
Environmental Research Lab
Department of Commerce
Boulder, CO 80302
Attn: George C. Reid
Aeronomy Lab

Nat'l Oceanic & Atmospheric
Administration
Environmental Research Lab
Department of Commerce
Boulder, CO 80302
Attn: Eldon Ferguson

Nat'l Oceanic & Atmospheric
Administration
Environmental Research Lab
Department of Commerce
Boulder, CO 80302
Attn: Fred Fehsenfeld

Aero-Chem Resch Lab, Inc.
P.O. Box 12
Princeton, NJ 08540
Attn: A. Fontijn

Aero-Chem Resch Lab, Inc.
P.O. Box 12
Princeton, NJ 08540
Attn: H. Pergament

Aerodyne Research, Inc.
Bedford Research Park
Crosby Drive
Bedford, MA 01730
Attn: F. Bien

Aerodyne Research, Inc.
Bedford Research Park
Crosby Drive
Bedford, MA 01730
Attn: M. Camac

Aeronomy Corporation
217 S. Neil Street
Champaign, IL 61828
Attn: A. Bowhill

Aerospace Corporation
P.O. Box 92957
Los Angeles, CA 90009
Attn: N. Cohen

Aerospace Corporation
P.O. Box 92957
Los Angeles, CA 90009
Attn: Harris Mayer

Aerospace Corporation
P.O. Box 92957
Los Angeles, CA 90009
Attn: Sidney W. Kash

Aerospace Corporation
P.O. Box 92957
Los Angeles, CA 90009
Attn: T. Widhopf

Aerospace Corporation
P.O. Box 92957
Los Angeles, CA 90009
Attn: R. J. McNeal

Aerospace Corporation
P.O. Box 92957
Los Angeles, CA 90009
Attn: R. Grove

Aerospace Corporation
P.O. Box 92957
Los Angeles, CA 90009
Attn: Irving M. Garfunkel

Aerospace Corporation
P.O. Box 92957
Los Angeles, CA 90009
Attn: Thomas D. Taylor

Aerospace Corporation
P.O. Box 92957
Los Angeles, CA 90009
Attn: V. Josephson

Aerospace Corporation
P.O. Box 92957
Los Angeles, CA 90009
Attn: Julian Reinheimer

Aerospace Corporation
P.O. Box 92957
Los Angeles, CA 90009
Attn: R. D. Rawcliffe

Avco-Everett Research Lab, Inc.
2385 Revere Beach Parkway
Everett, MA 02149
Attn: Technical Library

Avco-Everett Research Lab, Inc.
2385 Revere Beach Parkway
Everett, MA 02149
Attn: George Sutton

Battelle Memorial Institute
505 King Avenue
Columbus, OH 43201
Attn: Donald J. Hamman

Battelle Memorial Institute
505 King Avenue
Columbus, OH 43201
Attn: Donald J. Ham

Battelle Memorial Institute
505 King Avenue
Columbus, OH 43201
Attn: STOIAC

Battelle Memorial Institute
505 King Avenue
Columbus, OH 43201
Attn: Richard K. Thatcher

Brown Engineering Co., Inc.
Cummings Research Park
Huntsville, AL 35807
Attn: N. Passino

The Trustees of Boston College
Chestnut Hill Campus
Chestnut Hill, MA 02167
Attn: Chairman Dept. of Chem.

Brown Engineering Co., Inc.
Cummings Research Park
Huntsville, AL 35807
Attn: Ronald Patrick

California at Riverside, Univ. of
Riverside, CA 92502
Attn: Alan C. Lloyd

California at Riverside, Univ. of
Riverside, CA 92502
Attn: James N. Pitts, Jr.

California at San Diego, Univ. of
3175 Miramar Road
La Jolla, CA 92037
Attn: S. C. Lin

California University of
Berkeley Campus Room 318
Sproul Hall
Berkeley, CA 94720
Attn: Sec Officer for
Harold Johnston

California University of
Berkeley Campus Room 318
Sproul Hall
Berkeley, CA 94720
Attn: Sec Officer for F. Mozer

California University of
Berkeley Campus Room 318
Sproul Hall
Berkeley, CA 94720
Attn: Sec Officer for Dept of
Chem. W. H. Miller

California, State of
Air Resources Board
9528 Telstar Avenue
El Monte, CA 91731
Attn: Leo Zafonte

Calspan Corporation
P.O. Box 235
Buffalo, NY 14221
Attn: C. E. Treanor

Calspan Corporation
P.O. Box 235
Buffalo, NY 14221
Attn: G. C. Valley

Calspan Corporation
P.O. Box 235
Buffalo, NY 14221
Attn: M. G. Dunn

Calspan Corporation
P.O. Box 235
Buffalo, NY 14221
Attn: W. Wurster

Colorado, University of
Office of Contracts & Grants
380 Administrative Annex
Boulder, CO 80302
Attn: A. Phelps JILA

Colorado, University of
Office of Contracts & Grants
380 Administrative Annex
Boulder, CO 80302
Attn: Jeffrey B. Pearce LASP

Colorado, University of
Office of Contracts & Grants
380 Administrative Annex
Boulder, CO 80302
Attn: C. Beaty JILA

Colorado, University of
Office of Contracts & Grants
380 Administrative Annex
Boulder, CO 80302
Attn: C. Lineberger JILA

Colorado, University of
Office of Contracts & Grants
380 Administrative Annex
Boulder, CO 80302
Attn: C. A. Barth LASP

Columbia University, Trustees
City of New York
La Mont Doherty Geological
Observatory-Torrey Cliff
Palisades, NY 19064
Attn: B. Phelan

Columbia University, Trustees
City of New York
116th Street & Broadway
New York, NY 10027
Attn: Richard N. Zare

Columbia University, Trustees
City of New York
116th & Broadway
New York, NY 10027
Attn: Sec Officer H.M. Foley

Concord Sciences
P.O. Box 113
Concord, MA 01742
Attn: Emmett A. Sutton

Denver, University of
Colorado Seminary
Denver Research Institute
P.O. Box 10127
Denver, CO 80210
Attn: Sec. Officer for Van Zyl

Denver, University of
Colorado Seminary
Denver Research Institute
P.O. Box 10127
Denver, CO 80210
Attn: Sec Officer for D. Murcray

General Electric Company
Tempo-Center for Advanced Studies
816 State Street (P.O. Drawer QO)
Santa Barbara, CA 93102
Attn: DASAIC

General Electric Company
Tempo-Center for Advanced Studies
816 State Street (PO Drawer QO)
Santa Barbara, CA 93102
Attn: Warren S. Knapp

General Electric Company
Tempo-Center for Advanced Studies
816 State Street (PO Drawer QO)
Santa Barbara, CA 93102
Attn: Tim Stephens

General Electric Company
Tempo-Center for Advanced St.
816 State St. (PO Drawer QO)
Santa Barbara, CA 93102
Attn: Don Chandler

General Electric Company
Tempo-Center for Advanced St.
816 State St. (PO Drawer QO)
Santa Barbara, CA 93102
Attn: B. Cambill

General Elec. Co. Space Div.
Valley Forge Space Center
Goddard Blvd.
King of Prussia
P.O. Box 8555
Philadelphia, PA 19101
Attn: M. H. Bortner
Space Science Lab

General Elec. Co. Space Div.
Valley Forge Space Center
Goddard Blvd. King of Prussia
P.O. Box 8555
Philadelphia, PA 19101
Attn: J. Burns

General Elec. Co. Space Div.
Valley Forge Space Center
Goddard Blvd. King of Prussia
P.O. Box 8555
Philadelphia, PA 19101
Attn: F. Alyea

General Elec. Co. Space Div.
Valley Forge Space Center
Goddard Blvd. King of Prussia
P.O. Box 8555
Philadelphia, PA 19101
Attn: P. Z. Sands

General Elec. Co. Space Div.
Valley Forge Space Center
Goddard Blvd. King of Prussia
P.O. Box 8555
Philadelphia, PA 19101
Attn: R. H. Edsall

General Elec. Co. Space Div.
Valley Forge Space Center
Goddard Blvd. King of Prussia
P.O. Box 8555
Philadelphia, PA 19101
Attn: T. Baurer

General Research Corporation
P.O. Box 3587
Santa Barbara, CA 93105
Attn: John Ise, Jr.

Geophysical Institute
University of Alaska
Fairbanks, AK 99701
Attn: D. Henderson

Geophysical Institute
University of Alaska
Fairbanks, AK 99701
Attn: J. S. Wagner Physics Dept.

Geophysical Institute
University of Alaska
Fairbanks, AK 99701
Attn: B. J. Watkins

Geophysical Institute
University of Alaska
Fairbanks, AK 99701
Attn: T. N. Davis

Geophysical Institute
University of Alaska
Fairbanks, AK 99701
Attn: R. Parthasarathy

Geophysical Institute
University of Alaska
Fairbanks, AK 99701
Attn: Neal Brown

Lowell, University of
Center for Atmospheric Research
450 Aiken Street
Lowell, MA 01854
Attn: G. T. Best

Lockheed Missiles & Space Co.
3251 Hanover Street
Palo Alto, CA 94304
Attn: John Kumer Dept 52-54

Lockheed Missiles & Space Co.
3251 Hanover Street
Palo Alto, CA 94304
Attn: John Cladis Dept 52-12

Lockheed Missiles & Space Co.
3251 Hanover Street
Palo Alto, CA 94304
Attn: B. McCormac Dept 52-54

Lockheed Missiles & Space Co.
3251 Hanover Street
Palo Alto, CA 94304
Attn: T. James Dept 52-54

Lockheed Missiles & Space Co.
3251 Hanover Street
Palo Alto, CA 94304
Attn: B. Reagan Dept 52-12

Lockheed Missiles & Space Co.
3251 Hanover Street
Palo Alto, CA 94304
Attn: M. Walt Dept 52-10

Lockheed Missiles & Space Co.
3251 Hanover Street
Palo Alto, CA 94304
Attn: R. Johnson Dept 52-12

Lockheed Missiles & Space Co.
3251 Hanover Street
Palo Alto, CA 94304
Attn: R. Sears Dept 52-14

Lockheed Missiles & Space Co.
3251 Hanover Street
Palo Alto, CA 94304
Attn: J. R. Winkler

Institute for Defense Analyse
400 Army-Navy Drive
Arlington, VA 22202
Attn: Ernest Bauer

Institute for Defense Analyse
400 Army-Navy Drive
Arlington, VA 22202
Attn: Hans Wolfhard

Mission Research Corporation
735 State Street
Santa Barbara, CA 93101
Attn: D. Archer

Mission Research Corporation
735 State Street
Santa Barbara, CA 93101
Attn: D. Fischer

Mission Research Corporation
735 State Street
Santa Barbara, CA 93101
Attn: M. Scheibe

Mission Research Corporation
735 State Street
Santa Barbara, CA 93101
Attn: D. Sappenfield

Mission Research Corporation
735 State Street
Santa Barbara, CA 93101
Attn: D. Sowle

Photometrics, Inc.
442 Marrett Road
Lexington, MA 02173
Attn: Irving L. Kofsky

Physical Dynamics, Inc.
P.O. Box 1069
Berkeley, CA 94701
Attn: J. B. Workman

Physical Dynamics, Inc.
P.O. Box 1069
Berkeley, CA 94701
Attn: A. Thompson

Physical Sciences, Inc.
30 Commerce Way
Woburn, MA 01801
Attn: Kurt Wray

Physical Sciences, Inc.
30 Commerce Way
Woburn, MA 01801
Attn: R. L. Taylor

Physical Sciences, Inc.
30 Commerce Way
Woburn, MA 01801
Attn: G. Caledonia

Physics International Co.
2700 Merced Street
San Leandro, CA 94577
Attn: Doc Con for Tech Lib

Pittsburgh, University of
Commonwealth Sys of Higher Ed.
Cathedral of Learning
Pittsburgh, PA 15213
Attn: Wade L. Fite

Pittsburgh, University of
Commonwealth Sys of Higher Ed.
Cathedral of Learning
Pittsburgh, PA 15213
Attn: Manfred A. Biondi

Pittsburgh, University of
Commonwealth Sys of Higher Ed.
Cathedral of Learning
Pittsburgh, PA 15213
Attn: Frederick Kaufman

Pittsburgh, University of
Commonwealth Sys of Higher Ed.
Cathedral of Learning
Pittsburgh, PA 15213
Attn: Edward Gerjuoy

Princeton Univ. Trustees of
Forrestal Campus Library
Box 710
Princeton University
Princeton, NJ 08540

R & D Associates
P.O. Box 9695
Marina Del Rey, CA 90291
Attn: Richard Latter

R & D Associates
P.O. Box 9695
Marina Del Rey, CA 90291
Attn: R. G. Lindgren

Science Applications, Inc.
P.O. Box 2351
La Jolla, CA 92038
Attn: Daniel A. Hamlin

R & D Associates
P.O. Box 9695
Marina Del Rey, CA 90291
Attn: Bryan Gabbard

Science Applications, Inc.
P.O. Box 2351
La Jolla, CA 92038
Attn: David Sachs

R & D Associates
P.O. Box 9695
Marina Del Rey, CA 90291
Attn: H. A. Oru

Space Data Corporation
1333 W. 21st St.
Tempe, AZ 85282
Attn: Edward F. Allen

R & D Associates
P.O. Box 9695
Marina Del Rey, CA 90291
Attn: Robert E. Lelevier

SRI International
333 Ravenswood Avenue
Menlo Park, CA 94025
Attn: M. Baron

R & D Associates
P.O. Box 9695
Marina Del Rey, CA 90291
Attn: R. P. Turco

SRI International
333 Ravenswood Avenue
Menlo Park, CA 94025
Attn: L. Leadabrand

R & D Associates
P.O. Box 9695
Marina Del Rey, CA 90291
Attn: Forrest Gilmore

SRI International
333 Ravenswood Avenue
Menlo Park, CA 94025
Attn: Walter G. Chestnut

R & D Associates
P.O. Box 9695
Marina Del Rey, CA 90291
Attn: D. Dee

SRI International
1611 North Kent Street
Arlington, VA 22209
Attn: Warren W. Berning

R & D Associates
1815 N. Ft. Myer Drive 11th fl.
Arlington, VA 22209
Attn: Herbert J. Mitchell

SRI International
1611 North Kent Street
Arlington, VA 22209
Attn: Charles Hulbert

R & D Associates
1815 N. Ft. Myer Drive 11th fl.
Arlington, VA 22209
Attn: J. W. Rosengren

Stewart Radiance Laboratory
1 DeAngelo Drive
Bedford, MA 01730
Attn: R. J. Huppi
(25 copies)

Rand Corporation
1700 Main Street
Santa Monica, CA 90406
Attn: Cullen Crain

Technology International Corp.
75 Wiggins Avenue
Bedford, MA 01730
Attn: W. P. Roquist

United Technologies Corp.
755 Main Street
Hartford, CT 06103
Attn: H. Michels

United Technologies Corp.
755 Main Street
Hartford, CT 06103
Attn: Robert Bullis

Utah State University
Logan, UT 84322
Attn: Doran Baker

Utah State University
Logan, UT 84322
Attn: Kay Baker

Utah State University
Logan, UT 84322
Attn: C. Wyatt

Utah State University
Logan, UT 84322
Attn: D. Burt

Visidyne, Inc.
19 Third Avenue
Northwest Industrial Park
Burlington, MA 01803
Attn: Henry J. Smith

Visidyne, Inc.
19 Third Avenue
Northwest Industrial Park
Burlington, MA 01803
Attn: J. W. Carpenter

Visidyne, Inc.
19 Third Avenue
Northwest Industrial Park
Burlington, MA 01803
Attn: William Reidy

Visidyne, Inc.
19 Third Avenue
Northwest Industrial Park
Burlington, MA 01803
Attn: T. C. Degges

Visidyne, Inc.
19 Third Avenue
Northwest Industrial Park
Burlington, MA 01803
Attn: Charles Humphrey

Visidyne, Inc.
19 Third Avenue
Northwest Industrial Park
Burlington, MA 01803
Attn: J. Reed

Wayne State University
1064 MacKenzie Hall
Detroit, MI 48202
Attn: Pieter K. Rol
Chem Engrg & Mat Sci

Wayne State University
1064 MacKenzie Hall
Detroit, MI 48202
Attn: R. H. Kummler

Wayne State University
Dept. of Physics
Detroit, MI 48202
Attn: Walter E. Kauppila

Yale University
New Haven, CT 06520
Attn: Engineering Dept.

AF Geophysics Laboratory, AFSC
Hanscom AFB, MA 01731
Attn: OPR B. Sandford
(10 copies)

Director
Defense Advanced Rsch Proj Agcy
Architect Building
1400 Wilson Blvd.
Arlington, VA 22209
Attn: S. Zakanycz /STO

Director
Defense Advanced Rsch Proj Agcy
Architect Building
1400 Wilson Blvd.
Arlington, VA 22209
Attn: P. Clark /STO

Director
Defense Advanced Rsch Proj Agcy
Architect Building
1400 Wilson Blvd.
Arlington, VA 22209
Attn: E. Kopf /STO

Director
Defense Advanced Rsch Proj Agcy
Architect Building
1400 Wilson Blvd.
Arlington, VA 22209
Attn: Program Management
(MIS Division)
(2 copies)

Director
Defense Advanced Rsch Proj Agcy
Architect Building
1400 Wilson Blvd.
Arlington, VA 22209
Attn: J. Jenney /STO

Commander
Naval Electronics Systems Command
Naval Electronics Systems Command Hq.
Washington, DC 20360
Attn: PME 117

OSD-ASDI the Pentagon
Washington, DC 20301
Attn: Mr. W. Henderson

OSD-ASDI the Pentagon
Washington, DC 20301
Attn: Mr. A. Albrecht

US Arms Control & Disarmament
Agency
Department of State
Washington, DC 20451
Attn: Dr. F. Elmer

Commander, US Army Missile
Command
Redstone Arsenal, AL 35809
Attn: DRDMI-NS Mr. Drake

Commander, US Army Missile
Command
Redstone Arsenal, AL 35809
Attn: DRDMI/REI Mr. Jackson

Missile Intelligence Agency
Redstone Arsenal
Huntsville, AL 35809
Attn: DRSMI-YDL

Hq USAF
Washington, DC 20330
Attn: Col L. Deliso, RDSD

Hq USAF
Washington, DC 20330
Attn: Lt Col C. Heimach, RDSD

Hq USAF
Washington DC 20330
Attn: Lt Col G. Watts, RDSD

Air Force Systems Command
Andrews Air Force Base
Washington, DC 20334
Attn: Capt D. Beadner, DLCEA

Air Force Systems Command
Andrews Air Force Base
Washington, DC 20334
Attn: Maj W. Kurowski, XRID

SAMSO, P.O. Box 92960
Worldwide Postal Center
Los Angeles, CA 90009
Attn: Col J. McCormick, SZ

SAMSO, P.O. Box 92960
Worldwide Postal Center
Los Angeles, CA 90009
Attn: Col R. W. Johnson, DY

SAMSO, P.O. Box 92960
Worldwide Postal Center
Los Angeles, CA 90009
Attn: Lt Col R. Shields, SZD

SAMSO, P.O. Box 92960
Worldwide Postal Center
Los Angeles, CA 90009
Attn: Lt Col E. Gee, DYA

Rome Air Develop. Center, AFSSO
Griffiss Air Force Base
Rome, NY 13440
Attn: Mr. D. D. Dylis, IRAD

Air Force Propulsion Lab
Edwards Air Force Base, CA 93523
Attn: Dr. J. D. Stewart

Air Force Armament Lab
Eglin Air Force Base, FL 32542
Attn: Capt W. Rothschild, DLMQ

Foreign Technology Division
Wright-Patterson AFB OH 45433
Attn: Mr. T. Larson

Foreign Technology Division
Wright-Patterson AFB OH 45433
Attn: Mr. R. C. Frick

Air Force Avionics Lab
Air Force Systems Command
Wright-Patterson AFB, OH 45433
Attn: Mr. W. Edwards

Arnold Engineering Development
Center, TN 37389
Attn: Dr. H. E. Scott

Arnold Engineering Development
Center, TN 37389
Attn: Dr. W. K. McGregor

Arnold Engineering Development
Center, TN 37389
Attn: Dr. C. Peters

Naval Weapons Center
China Lake, CA 93555
Attn: Mr. W. L. Capps

Naval Weapons Center
China Lake, CA 93555
Attn: Dr. M. Benton

Naval Weapons Center
China Lake, CA 93555
Attn: Dr. L. Wilkins

Central Intelligence Agency
Washington, DC 20505
Attn: Mr. Bergquist

Aerospace Corporation
El Segundo Operations
P.O. Box 95085
Los Angeles, CA 90045
Attn: Dr. F. Simmons

Aerospace Corporation
El Segundo Operations
P.O. Box 95085
Los Angeles, CA 90045
Attn: Dr. R. Lee

Aerospace Corporation
El Segundo Operations
P.O. Box 95085
Los Angeles, CA 90045
Attn: Dr. C. Randall

Aerospace Corporation
El Segundo Operations
P.O. Box 95085
Los Angeles, CA 90045
Attn: Dr. H. Graff

Aerospace Corporation
El Segundo Operations
P.O. Box 95085
Los Angeles, CA 90045
Attn: Dr. J. Ator

Institute for Defense Analysis
400 Army-Navy Drive
Arlington, VA 22202
Attn: Dr. H. G. Wolfhard

Institute for Defense Analysis
400 Army-Navy Drive
Arlington, VA 22202
Attn: Dr. L. Biberman

Aerodyne Research, Inc.
Bedford Research Park
Crosby Drive
Bedford, MA 01730
Attn: Dr. J. Draper

Aerodyne Research Inc.
Bedford Research Park
Crosby Drive
Bedford, MA 01730
Attn: Dr. H. Camac

Block Engineering
19 Blackstone Street
Cambridge, MA 02139
Attn: Dr. M. Weinberg

Carson System, Inc.
4630 Campus Drive
Newport Beach, CA 92660
Attn: Dr. John Carson

CALSPAN
4455 Genesee St.
Buffalo, NY 14221
Attn: Dr. C. Treanor

CALSPAN
4455 Genesee St.
Buffalo, NY 14221
Attn: Dr. W. Wurster

Environmental Research Inst of
Michigan
P.O. Box 618
Ann Arbor, MI 48107
Attn: Mr. G. Lindquist

Environmental Research Inst of
Michigan
P.O. Box 618
Ann Arbor, MI 48107
Attn: Mr. R. Legault

GASL
Merrick & Stewart Avenues
Westbury, NY 11590
Attn: R. R. Vaglio-Laurin

Grumman Aerospace Corp.
Research Dept - Plant 35
Bethpage, Long Island, NY 11714
Attn: Dr. M. Slack

Grumman Aerospace Corp.
Research Dept - Plant 35
Bethpage, Long Island, NY 11714
Attn: Dr. D. Moyer

Hughes Aircraft Company
Culver City, CA 90230
Attn: Mr. I. Sandback

Lockheed Missiles & Space Co.
3251 Hanover Street
Palo Alto, CA 94304
Attn: Dr. D. Pecka

Lockheed Missiles & Space Co.
3251 Hanover Street
Palo Alto, CA 94304
Attn: Dr. E. Smith

Riverside Research Institute
1701 Fort Myer Drive
Arlington, VA 22209
Attn: R. C. Passut

Rockwell International Corp.
Space Division/SF12
12214 S. Lakewood Blvd.
Downey, CA 90241
Attn: Richard T. Pohlman

Science Applications, Inc.
P.O. Box 2531
La Jolla, CA 92037
Attn: Dr. Jim Myer

Defense Intelligence Agency
Washington, DC 20301
Attn: Mr. S. Berler DT-1A

R&D Associates
4640 Admiralty Way
P.O. Box 9695
Marina Del Ray, CA 90291
Attn: Mr. Bryan Gabbard

General Electric Company
Aircraft Engine Group
Evandale Plant
Cincinnati, OH 45215
Attn: B. Wilton, Mail Code E198

Boeing Aerospace Co.
P.O. Box 3707
Seattle, WA 98124
Attn: D.M. Owens M/S 8H27

Northrup Aircraft Division
3901 W. Broadway
Hawthorne, CA 90250
Attn: Dr. J. Cashen

Air Force Avionics Lab
Wright-Patterson AFB, OH 45433
Attn: Dr. R. B. Sanderson/WRP

Air Force Avionics Lab
Wright-Patterson AFB, OH 45433
Attn: B. J. Sabo/WRA-1/Library

Aeronautical Systems Division
Wright-Patterson AFB, OH 45433
Attn: D.J. Wallick/ENFTV