

AD-A062 268

SOUTHWEST RESEARCH INST SAN ANTONIO TEX
DESIGN OF A WATER DELUGE TO EXTINGUISH M-1 PROPELLANT FIRES IN --ETC(U)
SEP 78 J W GEHRING, R M RINDNER, W O SEALS

F/G 13/12

DAAA21-76-C-0255

ARLCD-CR-78023

NL

UNCLASSIFIED

1 OF 1
AD
A0 62268

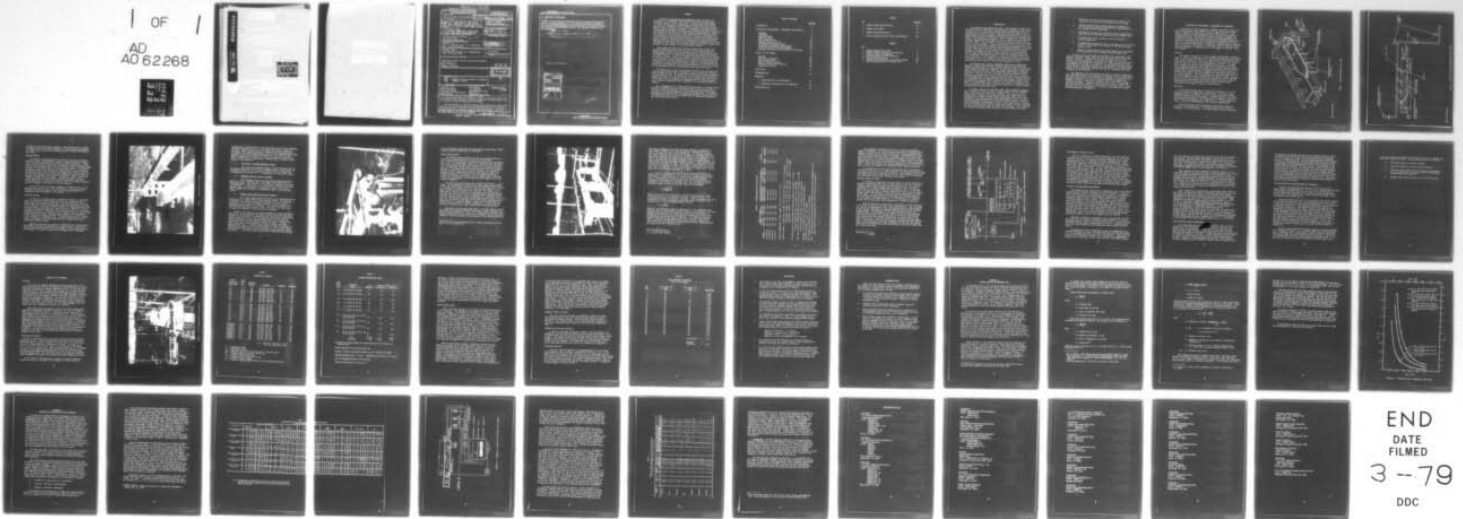

END
DATE
FILMED
3-79
DDC

AD A062268

JDC FILE COPY

DDC
RECEIVED
DEC 19 1978
B



Unclassified

18 ARLCD SBIE

SECURITY CLASSIFICATION OF THIS PAGE (When Data Entered)

REPORT DOCUMENTATION PAGE		READ INSTRUCTIONS BEFORE COMPLETING FORM
1. REPORT NUMBER Contractor Report ARLCD-CR-78023	2. GOVT ACCESSION NO. 19 CR-78023, AD-E488 326	3. RECIPIENT'S CATALOG NUMBER
4. TITLE (and Subtitle) 6 DESIGN OF A WATER DELUGE TO EXTINGUISH M-1 PROPELLANT FIRES IN CLOSED CONVEYORS.		5. TYPE OF REPORT & PERIOD COVERED 9 Final Report
7. AUTHOR(s) J. W. Gehring, SwRI R. M. Rindner, ARRADCOM, Project Leader W. Seals, ARRADCOM, Project Engineer		6. PERFORMING ORG. REPORT NUMBER
9. PERFORMING ORGANIZATION NAME AND ADDRESS Southwest Research Institute 328 200 6220 Culebra Road San Antonio, Texas 78284		8. CONTRACT OR GRANT NUMBER(s) 15 DAAA-21-76-C-0255
11. CONTROLLING OFFICE NAME AND ADDRESS ARRADCOM, TSD Scientific and Tech. Info. Div. (DRDAR-TSS) Dover, New Jersey 07801		10. PROGRAM ELEMENT, PROJECT, TASK AREA & WORK UNIT NUMBERS
14. MONITORING AGENCY NAME & ADDRESS (if different from Controlling Office) ARRADCOM, LCWSL Manufacturing Technology Div. (DRDAR-LCM-SP) Dover, New Jersey 07801		12. REPORT DATE 11 September 1978
		13. NUMBER OF PAGES 52
		15. SECURITY CLASS. (of this report) Unclassified
		15a. DECLASSIFICATION/DOWNGRADING SCHEDULE
16. DISTRIBUTION STATEMENT (of this Report) Approved for public release; distribution unlimited. 12 53 p.		
17. DISTRIBUTION STATEMENT (of the abstract entered in Block 20, if different from Report) DDC DEC 19 1978 B		
18. SUPPLEMENTARY NOTES 10 J. William /Gehring, Richard M. /Rindner William O. /Seals		
19. KEY WORDS (Continue on reverse side if necessary and identify by block number) Propellant fires Fire sensors Ammunition plant Propellant drying M-1 propellant hazards Plant modernization Army ammunition plant Production base modernization Radford AAP Fire detectors Ammunition plant safety		
20. ABSTRACT (Continue on reverse side if necessary and identify by block number) A water deluge system was designed to protect a vibrating conveyor line at Radford AAP which transports in-process propellant in various parts of the new Continuous Automated Single Base Line (CASBL). Full scale tests on a simulated conveyor line proved that a water deluge system can be effectively used to control propellant fires and to prevent the hazardous rise of pressure within the enclosed conveyor. An ultraviolet detector proved to be the most responsive type of fire sensor. → over		

DD FORM 1473 1 JAN 73 EDITION OF 1 NOV 68 IS OBSOLETE

328 200

Unclassified 78 10 26 027
SECURITY CLASSIFICATION OF THIS PAGE (When Data Entered)

20. ABSTRACT (Continued)

The use of this system will eliminate the costly fire gates which had been proposed. Since the pressure rise in the closed conveyor can be limited to less than 5.5×10^4 Pa (~8 psi), the proposed pressure vents can be eliminated. By using the more responsive UV detectors, the redundant IR detectors can also be abandoned.

55000 pa (approximately 8 psi)

Page 42 Is Misnumbered

ACCESSION for	
NTIS	White Section <input checked="" type="checkbox"/>
DOC	Buff Section <input type="checkbox"/>
UNANNOUNCED	<input type="checkbox"/>
JUSTIFICATION	
BY	
DEPARTMENT/BRANCH/UNIT CODES	
Dist. AVAIL. and/or SPECIAL	
A	

1473B

SUMMARY

In support of the Radford Army Ammunition Plant and under the direction of the ARRADCOM Manufacturing Technology Division, SwRI conducted a series of full-scale tests to evaluate the effectiveness of a water deluge system in combating an M-1 propellant fire and the prevention of a hazardous rise of pressure within an enclosed conveyor. The U.S. Army is currently involved in a Production Base Modernization Program under which many new explosive and propellant production facilities are being built and others are being renovated and modernized. Significant attention is being given to both increased safety and production efficiencies for the in-process operations. For each new facility such as the Continuous Automated Single Base Line (CASBL) at the Radford AAP, specific areas of the operations are singled out as being particularly hazardous and full-scale tests are then designed and conducted to evaluate the extent of this hazard and methods by which the personnel exposure and potential facility damage can be significantly reduced.

The program described in this report evaluated the various fire detection sensors which are available and a water deluge system was designed which could contain and extinguish a fire, and accomplish this extinguishment without a significant and hazardous pressure rise within the closed conveyor. Critical constraints were placed on the test series to conduct full-scale tests and to simulate building restrictions related to the proximity of roof and walls and the location of the detectors and construction of the water deluge system. Design of the water system had to consider the water pressure and water adequacy at the Radford AAP and ignition of the propellant fire was always assumed to occur at the bottom of the propellant bed, thus simulating the most severe fire case.

The results of the tests on the Radford conveyor line indicated that a water deluge system could be designed to operate within the available water pressure and that the system could control and eventually extinguish a closed conveyor fire. An evaluation of the available fire detectors demonstrated that a UV detector was the most reliable sensor and, because of its rapid action in sensing and triggering the water deluge system, a fire could be extinguished with negligible rise in pressure within the conveyor.

As a consequence of the demonstrated effectiveness of a deluge system, the report recommends that the proposed pressure relief ports in the conveyors could be eliminated and that the expensive fire gates between the cells at the Radford Ammunition Plant were unnecessary. This latter recommendation should result in a significant savings of money, both from the installation costs of the fire gates and the subsequent maintenance that would have been required.

TABLE OF CONTENTS

	<u>Page No.</u>
Introduction	1
Discussion of Experiments - Equipment and Techniques	3
Conveyor	3
Propellant	3
Ignition Source	6
Detector Systems	6
Water Deluge System	10
Sequence Timing of Events	14
Photographic Coverage of Tests	16
Pressure and Temperature Measurements	16
Propellant Burn Velocity Measurements	17
Propellant Recovery and Determination of Residue	18
Results of the Program	20
Overview	20
Propellant and Ignitor	20
Water Deluge System	24
Sequence Timing of Events	25
Pressure Rise and Burn Velocity	25
Propellant Recovery	25
Conclusions	27
Recommendations	28
Appendixes	
A Hazard Analysis of Pressure Rise	29
B Comparative Evaluation of Fire Detectors	35
Distribution List	43

TABLES

<u>No.</u>		<u>Page No.</u>
1	Radford Deluge Specifications	13
2	Radford Test Results	22
3	Radford Confirmatory Shots	23
4	M1-SP Propellant Recovery (Wet vs Dry Weight)	26

FIGURES

<u>No.</u>		
1	Radford Conveyor Test Setup	4
2	Sketch of Radford Conveyor Deluge System	5
3	Loaded Conveyor (Top Removed)	7
4	Detectors Mounted in End of Conveyor	9
5	Closed Radford Conveyor	11
6	Schematic of Water Deluge Event-Timing Network	15
7	View of Residue after 5.1 cm Layer Test	21

INTRODUCTION

At the Radford Army Ammunition Plant, a new facility is under construction for the production of single base M-1 propellant. This project is part of the U.S. Army Production Base Modernization Program which is charged with the responsibility of upgrading and renovating all of the Army ammunition plants to markedly increase production rate through automation, and to greatly increase plant safety through lower personnel exposure to the manufacturing hazards. This new facility is the Continuous Automated Single Base Line (CASBL) which is a modular type facility of concrete "cells". Each fireproof cell houses a process step in the manufacture of M-1 Propellant. Interconnecting each cell is a closed, vibrating conveyor line which transports the in-process propellant, and it is to this element of the process that Hazard Analysis indicated a potential problem. The Radford AAP encountered this problem when the firegate installation between the cells became prohibitive in cost, hence the use of a water deluge system to control the fire spread was suggested as a replacement for these firegates. Since this conveyor line is enclosed, the rate of fire spread and the subsequent pressure rise within the conveyor would, as a minimum, require very rapid fire detection and large quantities of water to control and extinguish the fire.

To address these problems, ARRADCOM, Manufacturing Technology Division, together with Southwest Research Institute, considered the design and installation of a water deluge system in light of construction costs, delays in production schedules, system complexities, water adequacy of the plant facility, and an expeditious time frame to complete the study. The first and most important question was whether a water deluge system regardless of cost or water application rate, could control and extinguish a large propellant fire in time to prevent transition to a detonation and the resultant major property damage. Should an M-1 propellant fire transcend into a detonation, the entire operation would have to be reclassified from a Class 1.3 fire hazard to a Class 1.1 explosive operation, thus either curtailing production or requiring expensive additional construction costs.

To answer these vital questions, SwRI, under ARRADCOM's guidance, was contracted to design and test a deluge system for use in fighting fires in full-scale M-1 propellant conveyors. The objective of the program was to evaluate the various fire detection sensors which are available and to design a water deluge system which could contain and extinguish a fire and accomplish this extinguishment without a significant and hazardous pressure rise within the closed conveyor. The proposed system had to be designed to control fires under the most critical in-plant conditions using a water deluge system which would be compatible with the in-plant water supply and water line pressures. Thus, critical but realistic constraints were placed on the test series as follows:

- Full-scale tests of a 3.96 m long section of conveyor containing up to 45.4 kg of M-1 propellant would be tested
- In-plant building restrictions relating to proximity of roof and walls, location of detectors and construction of the conveyor would be maintained
- Commercially available fire detectors would be evaluated to sense the fire at the most remote end of the conveyor line
- A maximum static water pressure of 620 kPa (90 psi) would be maintained
- A maximum water application rate of less than 611 liter per minute per sq. meter had to be achieved to meet in-plant water adequacy limits
- Ignition of the propellant fire would always be at the bottom of the propellant bed to simulate the most severe case

In Section II of this report the details of the experiments, the design of the water deluge system and the techniques used to record the data are discussed. Section III discusses the results of the test firings. Several significant conclusions are drawn from the test results with regard to the design and functioning of a deluge system and these conclusions are discussed in Section IV. By application of these results to the design of propellant manufacturing facilities it is believed that safety can be significantly improved and that the cumbersome and costly firegates can be eliminated.

Two appendices are included with the report to give the reader more depth and appreciation of the complexities involved, first in defining the fire hazard and second in the selection of equipment to attack the fire. Appendix A attempts to relate by analytical methods the quantity of propellant burned to the would-be pressure rise in the actual in-plant conveyor environment. Appendix B describes the results of almost 300 test firings made to compare the sensitivity and response times of three detectors (UV, IR, and visible) to a variety of fire sources as viewed through atmospheric contaminants.

DISCUSSION OF EXPERIMENTS - EQUIPMENT AND TECHNIQUES

The purpose of this program was to obtain the design criteria for water deluge systems to be installed in the vibrating conveyor lines used to transport M-1 propellant in the new CASBL facility. These design criteria were then implemented into a full-scale test program to demonstrate that the system will provide personnel, equipment and facility protection. The testing program to be described herein was conducted to determine the required operating characteristics and flow rates of a water deluge system to provide and to demonstrate the adequacy of the system design and to eliminate or minimize damage resulting from any incident. This section of the report will describe the equipment and experimental techniques used in the conduct of the test evaluation program.

Conveyor

The Radford conveyor test setup is shown schematically in Figures 1 and 2. All of the elements of the water deluge system have been identified. The conveyor was a steel box, 3.96m x 0.305m x 0.15m deep with the fire detectors mounted at one end, and ignition was caused by an electric match to occur at a point 3.81 m away from the detectors. The main water supply line with its primac high-speed valve control are shown in the schematic drawings, and the four nozzle deluge system is shown projecting through the steel lid which was placed over the conveyor and clamped into a fixed position. An exhaust port was left open in the bottom of the conveyor under the detectors to simulate the same port on the actual conveyor. The test conveyor was a more rigid test than in the actual ammunition plant conveyor for two reasons: first, the input port on the left end of the conveyor was omitted to allow for maximum pressure rise; and secondly, the pressure vent ports set to vent at approximately (2 psi overpressure) 14 kPa normally placed between the nozzles were omitted to allow the pressure rise.

Propellant

To evaluate the most severe in-plant fire condition, all of the tests were conducted using single perforated M-1 propellant grains measuring 0.0011 m in diameter x 0.0051 m long, and having a single 0.00033 m diameter hole in the center. The bulk density of the single perforated M-1 propellant is 624.8 kg/m³ and its chemical content is 84.2 percent nitrocellulose (13.15 percent N), 9.9 percent dinitrotoluene, 4.9 percent dibutylthalate, and 1 percent diphenylamine.

In the test series, the thickness of the propellant layer was varied; 2.5 cm uniform depth, 5 cm uniform depth, and a buildup of propellant at the ignition end. All tests used M-1 single perforated

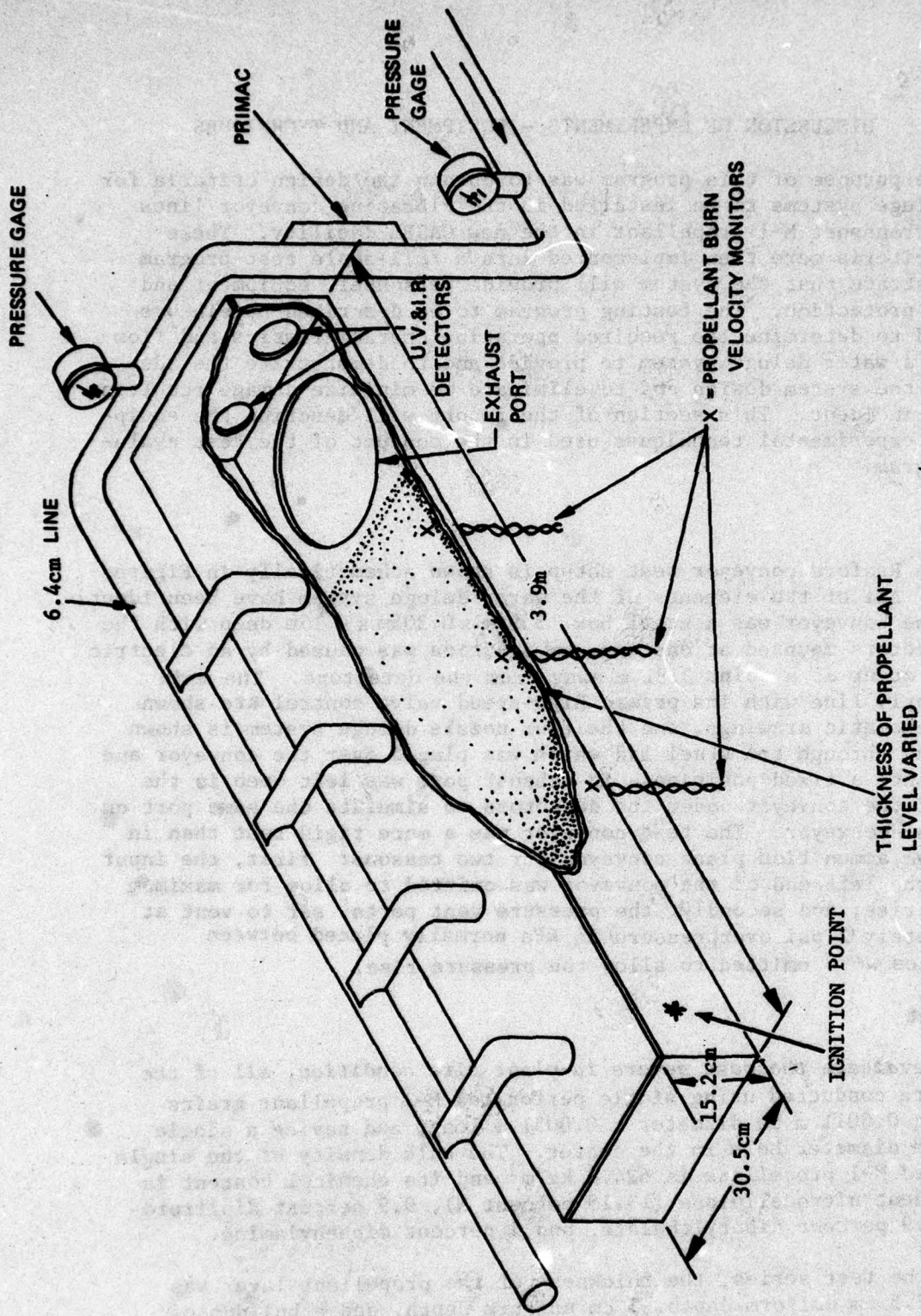

NOTE: NOT TO SCALE.

FIGURE 1. RADFORD CONVEYOR TEST SETUP

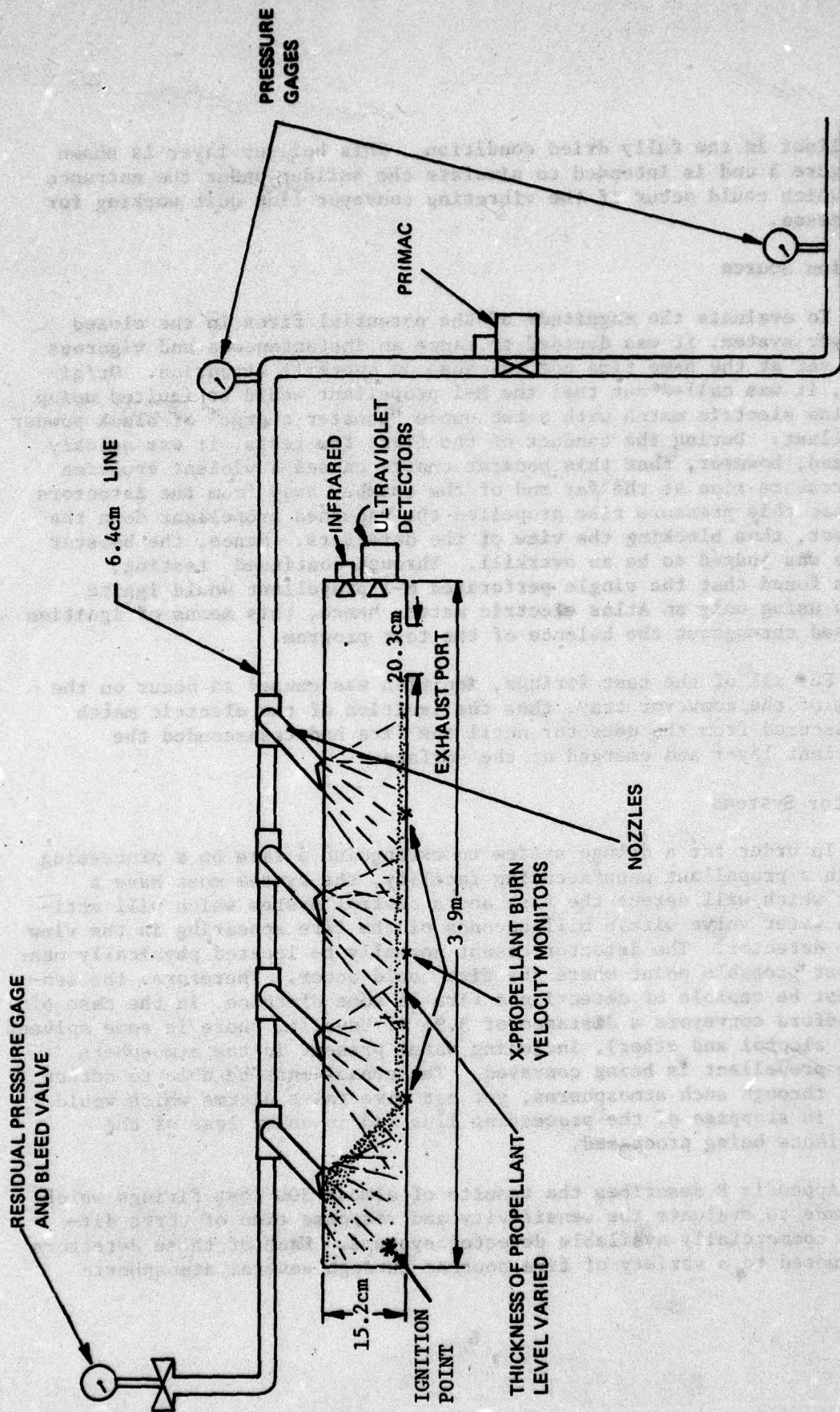

FIGURE 2. SKETCH OF RADFORD CONVEYOR DELUGE SYSTEM

propellant in the fully dried condition. This buildup layer is shown in Figure 3 and is intended to simulate the buildup under the entrance port which could occur if the vibrating conveyor line quit working for any reason.

Ignition Source

To evaluate the magnitude of the potential fires in the closed conveyor system, it was decided to cause an instantaneous and vigorous fire, yet at the same time not to cause an overkill situation. Originally, it was called out that the M-1 propellant would be ignited using an Atlas electric match with a two ounce "booster charge" of black powder propellant. During the conduct of the first few tests, it was quickly realized, however, that this booster charge caused a violent eruption and pressure rise at the far end of the chamber away from the detectors and that this pressure rise propelled the unburned propellant down the conveyor, thus blocking the view of the detectors. Hence, the booster charge was judged to be an overkill. Through continued testing, it was found that the single perforated M-1 propellant would ignite easily using only an Atlas electric match, hence, this means of ignition was used throughout the balance of the test program.

For all of the test firings, ignition was caused to occur on the bottom of the conveyor tray, thus the ignition of the electric match was obscured from the detector until the fire had transcended the propellant layer and emerged at the surface.

Detector Systems

In order for a deluge system to extinguish a fire on a processing line in a propellant manufacturing facility, the system must have a sensor which will detect the fire and a control system which will activate a water valve within milliseconds of the fire appearing in the view of the detector. The detector cannot normally be located physically near the most probable point where the fire could occur. Therefore, the sensor must be capable of detecting a fire at some distance, in the case of the Radford conveyors a distance of 3.96 m. Usually, there is some solvent (ethyl alcohol and ether), including water present in the atmosphere as the propellant is being conveyed. The sensor must be able to detect a fire through such atmospheres, yet not give false alarms which would result in stoppage of the processing line and in undue loss of the propellants being processed.

Appendix B describes the results of almost 300 test firings which were made to evaluate the sensitivity and response time of three different commercially available detector systems. Each of these detectors was exposed to a variety of fire sources through several atmospheric

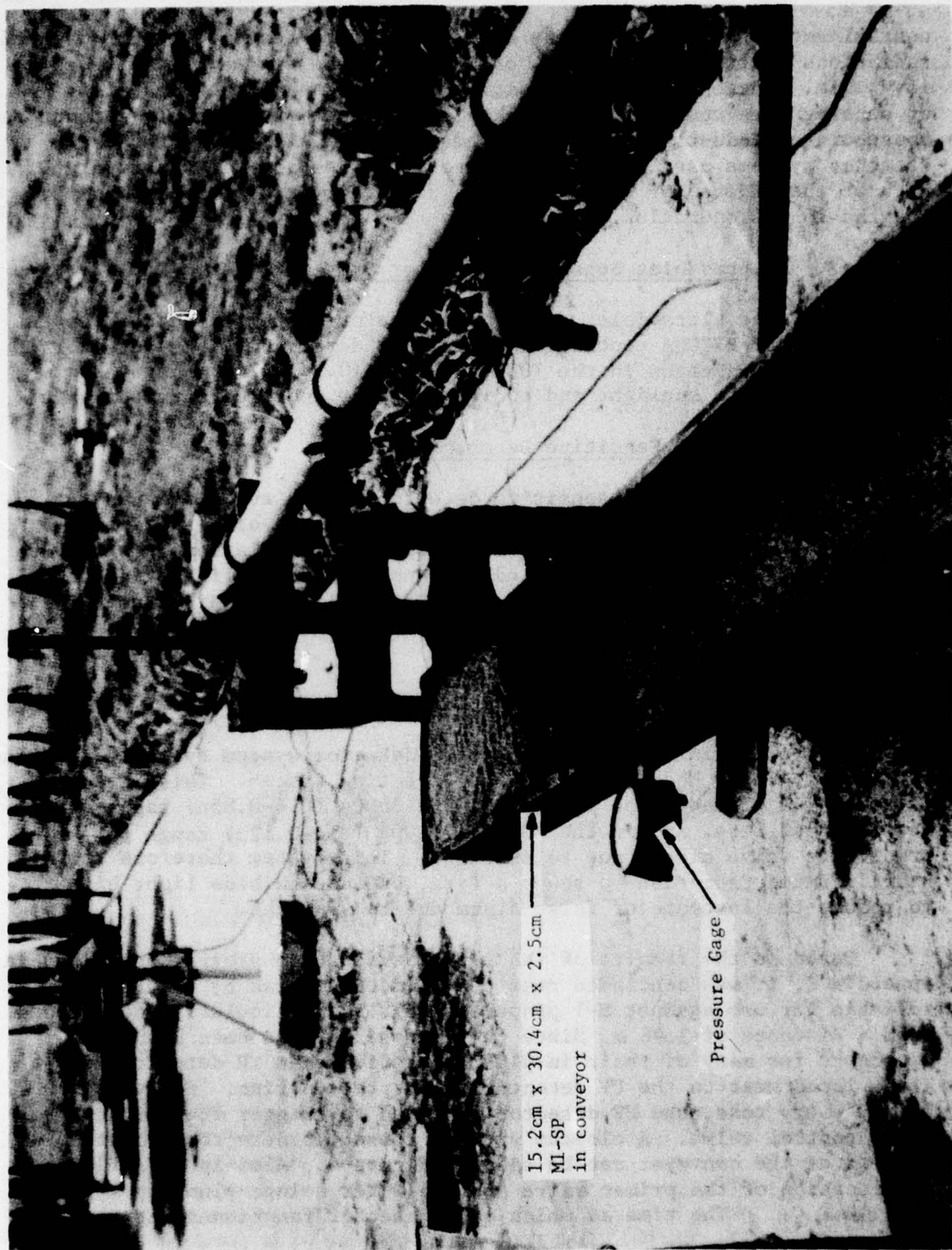

15.2cm x 30.4cm x 2.5cm
MI-SP
in conveyor

Pressure Gage

FIGURE 3. LOADED CONVEYOR (TOP REMOVED)

contaminants. All three of the detector systems react to electromagnetic radiations emitted by the fire, or in short, the flames, visible or invisible. These radiation sensitive detectors have the capability of sensing fire remotely and quickly, which the more commonly-encountered household or industrial sensor systems do not. All three of these detector systems use, or can use, a relay to operate the water valve. Each of these detector systems uses a different band of radiation wave lengths in its operation.

- Ultraviolet Sensitive Detector System

The ultraviolet sensitive detector system evaluated was the Det Tronics DE-R7300A controller and C7037B detector. This detector is sensitive to radiation in the 1850 to 2450Å (0.18-0.24μ) range, and is insensitive to sunlight and to incandescent and fluorescent lights.

- Infrared Sensitive Detector System

The infrared sensitive detector system evaluated was the American District Telegraph (ADT) 5925 SIGMAC ultra-high-speed fire detection system. This detector is sensitive to radiation in the 7000 to 28,000Å (0.7 - 2.8μ) range, and is sensitive to sunlight and incandescent light, but insensitive to fluorescent light. This system must be masked from sunlight or incandescent light to preclude false alarms.

- Visible Light Sensitive Detector System

The visible light sensitive detector system evaluated was the Pyrotector, Inc., Model Optical Fire Detection System. This detector is sensitive to radiation in the 6000 to 8500Å (0.6-0.85μ) range for detection of fire, and in the 4000 to 5200Å (0.4-0.52μ) range for precluding false alarms due to sunlight. This system therefore uses near infrared radiation to sense a fire, but uses a blue light bias to reduce the instance of false alarm due to sunlight.

Based on the results of the sensor evaluation program described in Appendix B, it was concluded that the UV detector was by far the most reliable for use against M-1 propellant fires, particularly when viewed from a distance of 3.96 m. Since the Radford AAP had been using IR detectors for many of their in-plant operations, an IR detector was also placed next to the UV detector in the test series. However, in nearly every test, the UV detector was used to trigger the primac water control valve. A closeup view of these two detectors mounted in the end of the conveyor can be seen in Figure 4. Also in this figure, the location of the primac valve and the water deluge plumbing system are shown. The time at which each detector functioned was recorded



FIGURE 4. DETECTORS MOUNTED IN END OF CONVEYOR

on an oscilloscope along with the other events as they occur. This sequence timing of events will be described.

Water Deluge System

The primary design criterion of any water deluge system is to provide the necessary liters per minute per square meter area coverage to be effective in quenching and eventually extinguishing a fire. The system must, however, be comparable with the static line pressures and the total water adequacy of the plant in which it is to be installed. These restrictions of water pressure and water adequacy at the Radford AAP were governing factors for the design of the water deluge to be used in the test program. For purposes of explanation, the complete water deluge system used by SwRI in the testing program will be described. The mounting of the deluge system over and into the conveyor was seen schematically in Figures 1 and 2, and a photograph of the closed conveyor ready to test fire is seen in Figure 5.

The SwRI field test program used a 15,140 liter tank as a water supply, and this supply was pumped to the water deluge system using a Hale pump, Model 50FB. This pump had a 12.7cm suction line and a 10.2 cm discharge line pumping water at 1,514 liters per minute at a distance of 137.2 m from the pump to the test pad. The output of the pump could be varied to control the effective static line pressure at the test site and to control the liters per minute discharge through the water deluge nozzles. Prior to testing, all of the water lines from the pump through the output nozzles were preprimed, and flow of the water was controlled by the use of an in-line Primac high-speed valve manufactured by the Grinnell Company. This valve uses two explosive primers (Hercules MK131) to shear a holding pin, at which time the line water pressure forces open a valve, thus releasing the water.

Downstream from the high-speed valve to the water deluge nozzles, the system was designed following the hydraulic design principles set forth in NFPA Standards Nos. 13 and 15.¹ Realistically, however, the SwRI test system had to be flexible so that changes could be instituted rapidly to evaluate the good and bad features of the design parameters.

¹"National Fire Protection Association," Boston, Massachusetts, Code Nos. 13 and 15, dated 1973.

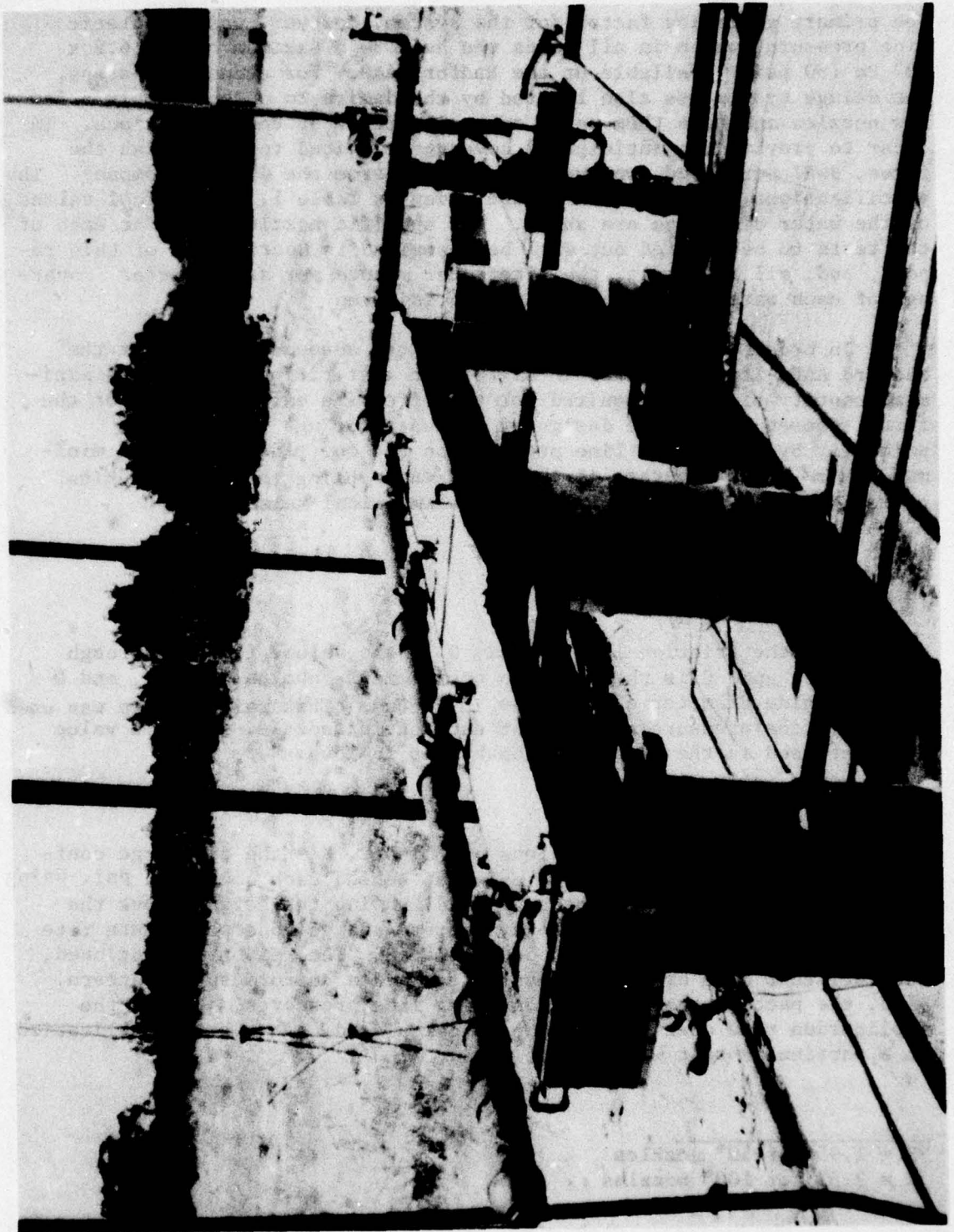

FIGURE 5. Closed Radford Conveyor

The primary governing factor for the system, however, was the static line pressure, which in all cases was held to a maximum of the 6.2×10^5 Pa (90 psig) available at the Radford AAP. For economic reasons, the deluge system was also limited by the desire to purchase only a few new nozzles and have them serve over a latitude of test conditions. In order to provide the anticipated coverage required to extinguish the fires, SwRI purchased two types of nozzles from the Grinnell Company. The specifications of these nozzles are given in Table 1, and typical values of the water discharge are shown. The specific nozzles used for each of the tests to be carried out will be described in Section III of this report, and, all important, the liters per minute per square meter coverage of each water deluge configuration is given.

In order to satisfy the critical water adequacy problem at the Radford AAP, it was desired in all of the test firings to use the minimum quantity of water required for the effective extinguishment of the fire. Consequently, the design of the water deluge was governed primarily by the static line pressure on the one side and by the minimum LPM/m² area coverage at the other end. Using the English units, hydraulic design criteria followed the empirical relationship

$$P = \frac{4.52 Q^{1.85}}{C^{1.85} D^{4.89}}$$

where P is the friction loss in psi, Q is the volume flowing through the pipe in gpm, C is the friction coefficient (nominally 120), and D is the inside diameter of the pipe in inches. This relationship was used to calculate the pressure existing at each outlet nozzle, and this value could be used in the next relationship as follows:

$$Q = K\sqrt{P}$$

where Q = the discharge in gallons per minute, K = the discharge coefficient*, and P is the pressure existent behind each nozzle in psi. Using a projection of the nozzle cone angle and knowing the height above the surface to be protected, the spray pattern and gallons per minute rate of application on the fire can be estimated. The reader is cautioned, however, that none of the nozzles tested had a uniform spray pattern. Also, the pattern changed with changing line pressures. Hence, the application rate over an area can be calculated, but not the application on a particular spot within that area.

*K = 1.95 for 50° nozzles
K = 2.52 for 100° nozzles

TABLE 1. RADFORD DELUGE SPECIFICATIONS

Nozzle	Water Pressure		Flow Rate (LPM) X No. of Nozzles + Square Meters of Conveyor (LPM/m ²)		Total	
	Static kPa (psi)	Residual kPa (psi)	Square Meters of Conveyor (LPM/m ²)	Square Feet of Conveyor (GPM/ft ²)	LPM/m ²	(GPM/ft ²)
S-1C-100-16	621 (90)	552 (88)	89 x 4/1.21	23.6 x 4/13	208	(7.3)
S-1C-100-16	345 (50)	345 (50)	67 x 4/1.21	17.8 x 4/13	224	(5.5)
S-1C-50-12	621 (90)	607 (88)	69 x 4/1.21	18.3 x 4/13	232	(5.7)
S-1C-50-12	245 (50)	331 (48)	51 x 4/1.21	13.5 x 4/13	171	(4.2)

Conveyor Dimensions: .305m x 3.96m x 15.2 cm (1' x 13' x 6")

Conveyor Volume: 15.2cm deep = $0.18m^3$ = 184 liters (6" deep = $6.5 ft^3$ = 48.6 gals)

5.1cm deep = $0.06m^3$ = 61 liters (2" deep layer = $2.16 ft^3$ = 16.2 gals)

2.5cm deep = $0.03m^3$ = 31 liters (1" deep layer = $1.08 ft^3$ = 8.1 gals)

50° Nozzle @ 621 x 10^4 Pa yields 69 liters per minute x 4 nozzles = 277 LPM

(@ 90 psi yields 18.3 gpm x 4 nozzles = 73.2 total gpm)

100° Nozzle @ 621 x 10^3 Pa yields 89 liters per minute x 4 nozzles = 357 LPM

(@ 90 psi yields 23.6 gpm x 4 nozzles = 94.4 total gpm)

Therefore, for a typical 10 sec burn time using 100° nozzles,

357 LPM x 0.166 min + $1.21m^2$ = $49.3 LPM/m^2$

(94.4 gal/min x 0.166 min + $13 ft^2$) to extinguish.

Note: All nozzles were fitted with blow-off plastic caps to allow prepriming of line.

Caps blow-off at approximately 140×10^3 Pa (20 psi) line pressure.

Two experimental techniques were used to verify the hydraulic design calculations. The first technique consisted of placing pressure gauges at various points along the main water line and monitoring the residual pressure while the water was flowing. Simultaneously, a pitot tube was placed under each nozzle to determine the rate of water flow from that nozzle. The second experimental technique consisted of using simple catch buckets which were placed on the conveyor trays at the same distance from the nozzle as would be the propellant in the experimental tests. These catch buckets had a known presented area, hence the rate of water flow into the buckets as a function of time could be monitored.

It is significant to note that by calculation and by experimental verification that the rate of water application as determined by all three techniques varied by no more than 10 percent. The reported values of LPM per square meter given in Section III of this report reflect an average value obtained from the three techniques noted above.

Sequence Timing of Events

To validate the response of the fire sensor to detect the fire, to actuate a high-speed valve, and to release water to the fire, the time response of each event for each test shot was monitored. The event timing network is shown schematically in Figure 6, and each event is monitored as a function of time from the ignition pulse. In the schematic, the ignition pulse is shown to ignite the fire, start the oscilloscope traces, and activate a flash bulb which is monitored by a high-speed camera. The four-channel oscilloscope electronically monitors the time from the ignition pulse to the triggering of the UV detector, to the firing of the Primac detonator, to the shorting of a water-on switch, and in some cases to the triggering of a backup IR detector.

Special attention is called here to the points at which the times to be cited in Section III of this report were measured. Each investigator has his own experimental setup, and each measures the time response of the various instruments at possibly different points along the event timing network. For instance, in the tests described herein, the response time of the UV detector was monitored from the ignition pulse (A_I) to the activation of the sensor (D_O)*. The second oscilloscope trace measures the time between ignition and the output pulse of the detector relay (G_O). This is the pulse that triggers the Primac water valve. The third oscilloscope trace measures the time from the ignition pulse to the triggering of a simple mechanical switch which was placed under one of the water nozzles and was shorted as soon as the water came out of the nozzle (K_O).

*Subscript I = input
o = output

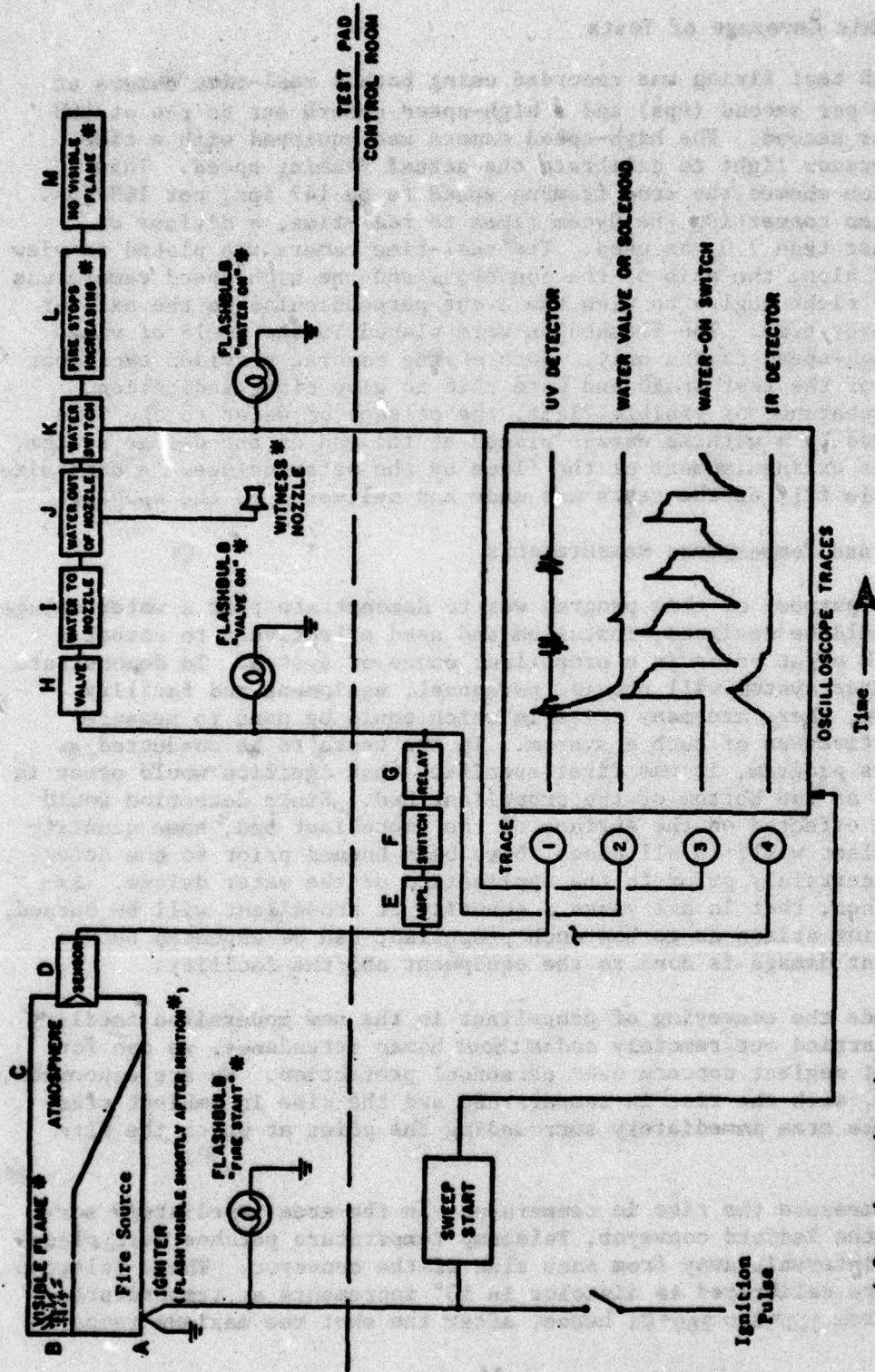

* Seen in motion pictures.

FIGURE 6. SCHEMATIC OF WATER DELUGE EVENT-TIMING NETWORK

Photographic Coverage of Tests

Each test firing was recorded using both a real-time camera at 24 frames per second (fps) and a high-speed camera set to run at 168 frames per second. The high-speed camera was equipped with a time-mark generator light to calibrate the actual framing speed. This calibration showed the true framing speed to be 147 fps, not 168 fps. Hence, when converting the Hycam times to real-time, a divisor of 6.09 rather than 7.0 was used. The real-time camera was placed to view the event along the axis of the conveyor, and the high-speed camera was placed at right angles to view the event perpendicular to the axis of the conveyor tray. The flashbulbs were placed in the field of view of the high-speed camera only. Both of the cameras provided excellent coverage of the test shots and were able to give clear indication of the appearance of visible flame, the release of water to the fire as measured by a witness nozzle placed at the end of the deluge system, and of the extinguishment of the flame by the water deluge. A composite 16-mm movie film of the tests was made and delivered to the sponsor.

Pressure and Temperature Measurements

The purpose of this program was to demonstrate that a water deluge system could be designed, installed and used effectively to combat a fire which might occur in a propellant conveyor system. To demonstrate that a water system will provide personnel, equipment and facility protection, there are many criteria which could be used to measure the effectiveness of such a system. In the tests to be conducted under this program, it was first specified that ignition would occur in all cases at the bottom of the propellant bed. Since detection would always be effected on the surface of the propellant bed, some quantity of propellant will, in all cases, have been burned prior to the detection and certainly prior to the application of the water deluge. Assuming, then, that in all cases a quantity of propellant will be burned, the question arises as to how much propellant can be expended before significant damage is done to the equipment and the facility.

Since the conveying of propellant in the new modernized facility will be carried out remotely and without human attendance, we can for the moment neglect concern over personnel protection. We are concerned, therefore, with the rise in temperature and the rise in ambient pressure in the area immediately surrounding the point at which the fire occurs.

To measure the rise in temperature in the area immediately surrounding the Radford conveyor, Teletemp temperature patches were placed at 3.1 m intervals away from each side of the conveyor. These Teletemp patches are calibrated to discolor in 10° increments at temperatures ranging from 3.1°C to 260°C ; hence, after the shot the maximum tempera-

ture as a function of distance away from the fire could be measured and recorded. Although these measurements are not precise, it is believed that they do reflect the nominal temperatures that would be felt by an adjacent piece of operating equipment or by a structural wall near the operating conveyor. One can use these approximate temperatures together with the recorded time-to-extinguish to estimate the possible damage caused to the equipment or the facility.

More important than the temperature increase caused by a conveyor fire would be the potential rise of internal pressure as a result of the gas generated during the burning of the propellant. This pressure rise could cause a catastrophic failure of the conveyor and possibly serious damage to adjacent equipment, the building housing the conveyor and to personnel within the vicinity of such an explosion. During the conduct of the first few experimental test firings, it was apparent that the burning of the propellant did not transcend into a high order detonation and that deformation or rupture of the conveyor did not occur.

With a desire to be certain that a catastrophic event would not take place, two steps were taken to determine quantitatively what the anticipated pressure rise could be in the conveyor being studied. Experimentally, pressure transducers and maxi-pointer pressure gages were placed in the conveyor as illustrated best in Figure 3. These transducers and pressure gages recorded values between 1.4 to 3.5×10^4 Pa. In addition, a more sophisticated approach was taken to be certain that those recorded pressures were valid and indeed there was no possibility of a catastrophic explosion. An analytical effort was undertaken to study the pressure buildup as a result of burning large quantities of M-1 propellant in a small and confined (sealed or partially sealed) conveyor. The approach to this analysis and the results obtained are given in detail in Appendix A of this report. The analysis did verify the experimentally determined pressure measurements in that, depending upon the vent area allowed in the conveyor, calculated pressures ranged from $0.7 - 5.9 \times 10^4$ Pa.

Propellant Burn Velocity Measurements

As an additional input to the analysis study, and as a definition of the effectiveness of a water deluge to control a propellant fire, it was desired to measure the rate at which the propellant burned in the conveyor. Burn velocity could then be translated into the quantity of propellant burned and, hence, the rate of gas evolution as a result of the fire. A simple technique of using twisted pair wire which would be shorted by the burning propellant and transmit a signal to a counterchronograph was used. This technique is usually simple and quite reliable. However, when a propellant bed

is ignited at the bottom, the rate of gas evolution causes an "eruption" which lifts and loosens the entire propellant bed, allowing for the venting of hot gases to the successive velocity measuring stations. Consequently, the recorded measurements were often totally out of order and misleading. The high-speed motion picture records revealed this eruption phenomenon and led to the abandonment of any further efforts to measure the burn velocity. Also, because of the rapid application of water, the propellant grains were wetted down, and the rate of burn was thus retarded. The above negative comments notwithstanding, propellant burn velocities in the neighborhood of 0.61 to 4.6 m per second were recorded, and these velocities do appear to be in keeping with the total burn time of a given fire and with the weight of the propellant recovered following a fire. Where applicable, the propellant burn velocities are reported and discussed in Section III of this report.

Propellant Recovery and Determination of Residue

No doubt, the most important measure of the success of the water deluge in extinguishing the fire was that of determining the weight of propellant recovered after the test shot. The reported data in Section III showed the percent of the original propellant mass which was recovered. The reported value always reflects the weight of the propellant in the "dried" state.

After each test firing, all of the propellant that was not burned in the test was recovered. Due to the gaseous eruption at the start of each test, and later to the forceful impingement of the water deluge, a significant quantity of loose propellant was always ejected from the conveyor bottom hole. This unburned material was gathered up immediately following the test firing, and this propellant was added to the propellant recovered from within the conveyor. The total mass of all propellant recovered was then weighed in the wet condition to allow for a determination of the water retention by the wet material. For field test operations, the total mass of recovered propellant was then spread out on a concrete pad and allowed to dry for three to four days before reweighing in the dried condition. It was then possible to record the percent of water retention and the percent of propellant recovered from each shot, and these values are given in Section III.

The test series consisted of firing a matrix of variables bounded by two primary variables, i.e., propellant depth and water application rate. Following a set of "preliminary" tests to assess the effectiveness of the deluge, the water application rate was fixed. Then a set of "confirmatory" tests was made to verify the deluge system. It is important to realize that these confirmatory tests were made under

restricted conditions designed to duplicate as closely as possible the real life in-plant situation. These restrictions were as follows:

- Full-scale tests in a shallow conveyor
- Detectors located 3.81 m from point of ignition
- Closed conveyor except for 0.2 m diameter bottom exhaust port (top input port and pressure vent port eliminated to make worst-case condition)
- Maximum static water pressure = 6.2×10^5 Pa (90 psig)

RESULTS OF THE PROGRAM

Overview

The total test program consisted of fifty-six (56) shots, 29 of which were fired to check out the diagnostic instrumentation and to make qualitative evaluation of several important factors. It was first realized that the full burn (without water deluge) of the entire conveyor contents would not cause a pressure rise sufficient to rupture the conveyor; and second, that a water deluge, of any small quantity, would act to suppress the fire, lengthen the total burn time, and result in some quantity of propellant "recovered". As was noted in Section II, the measure of propellant recovered was only one means used to assess the success of the test. For purposes of illustration, Figure 7 shows the residue 32.3 kg recovered from shot No. 46 (original weight of 5.1 cm layer = 38.1 kg. Therefore, 85 percent was recovered.

Twenty-seven shots were made to evaluate the water deluge effectiveness in suppressing the Radford Conveyor fires, and the summary of these tests is given in Table 2. Shown here are the results of 17 "preliminary" tests and also 10 "confirmatory" tests. The preliminary tests evaluated the variables of UV vs IR detectors, open vs closed conveyor, and the effects of water pressure and nozzle spray angle in attacking and extinguishing fires in several thicknesses of propellant. Following the preliminary shots a best estimate was made as to the most effective deluge system, and the series of 10 confirmatory shots (all shots fired using identical detector and deluge system) was fired. For convenience, the results of these 10 confirmatory shots are summarized in Table 3 for each of three propellant thickness variations. A review of these data and the observations made during all 56 Radford Conveyor tests follow.

Propellant and Ignitor

For all of the shots fired in this test series, M1-single perforated propellant was used. The loose propellant was loaded into the conveyor and leveled off to a depth of either 2.5 cm (19.1 kg), 5.1 cm (38.1 kg) or with a buildup layer that is described in Table 2 as being 15.2 x 15.2 x 2.5 cm (27.7 kg) or 12.5 x 30.4 x 2.5 cm (29.5 kg), and lastly, 15.2 x 45.7 x 2.5 cm (37.6 kg). Each of these buildup layers is intended to simulate the condition in the AAP plant wherein the conveyor stops vibrating and the propellant would pile up at one end due to the influx from the loading chute. For the buildup cases, the remaining propellant level throughout the length of the conveyor was held constant at 2.5 cm.

At the outset of the experiments a number of different ignition sources were used, all intended to be examined for their ability to

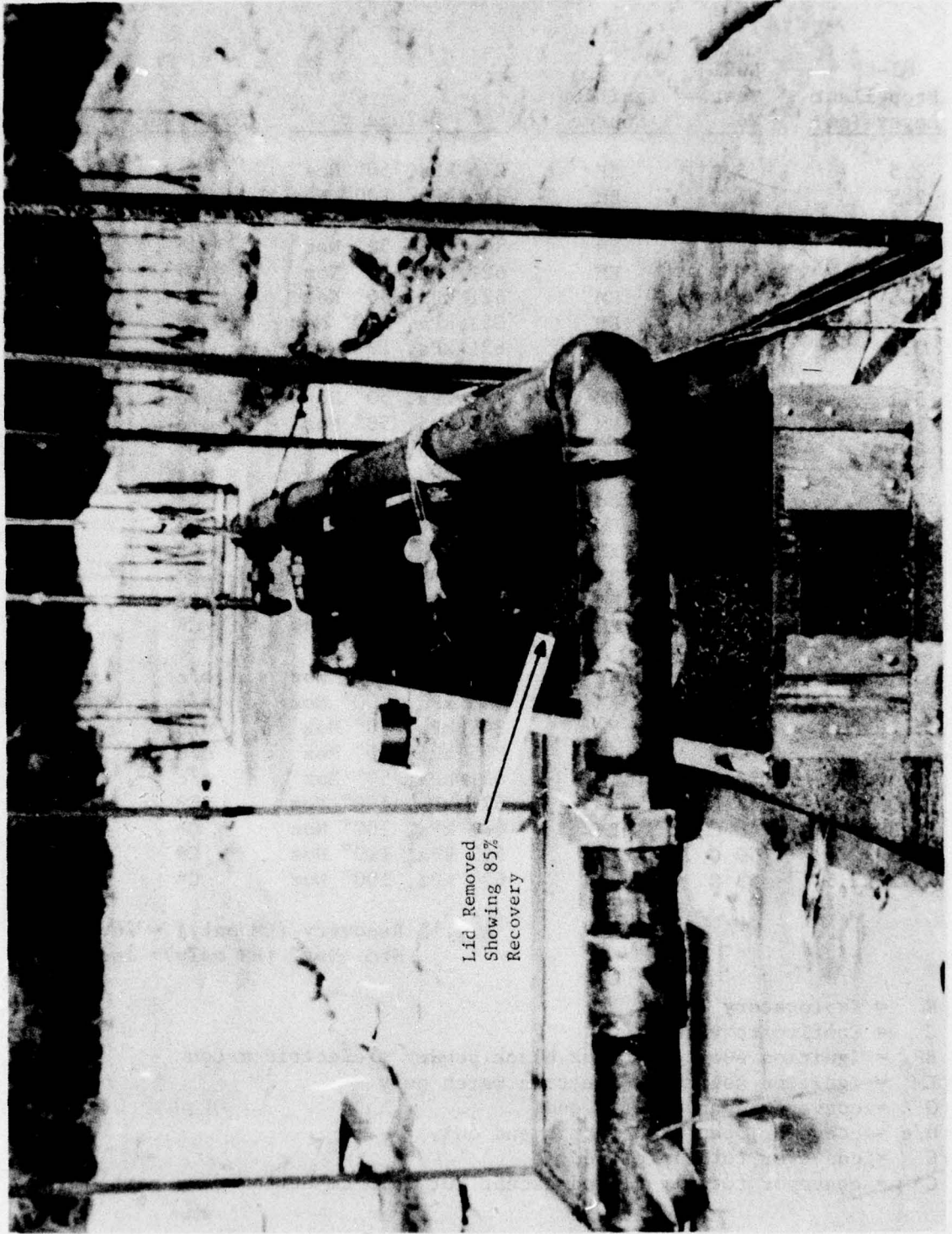

Lid Removed
Showing 85%
Recovery

FIGURE 7. VIEW OF RESIDUE AFTER 5-1cm LAYER TEST

TABLE 2
RADFORD TEST RESULTS

<u>Ml-SP Propellant Layer (cm)</u>	<u>SwRI Test No.</u>	<u>Ignition Source</u>	<u>Deluge</u>	<u>Conveyor</u>	<u>% Recovery</u>
2.5	5 E	BP	276 kPa, 50° Noz	C	46
2.5	11 E	EM	345 kPa, 100° Noz	O	75
2.5	12 E	EM	345 kPa, 100° Noz	O	81
2.5	23 E	EM	345 kPa, 50° Noz	o/c	89
2.5	41 E	EM	621 kPa, 50° Noz	C*	92
2.5	44 E	EM	621 kPa, 50° Noz	C*	79
2.5	51 C	EM	621 kPa, 100° Noz	C*	71
2.5	54 C	EM	621 kPa, 100° Noz	C*	86
5.1	17 E	EM	345 kPa, 50° Noz	o/c	74
5.1	18 E	EM	345 kPa, 50° Noz	o/c	83
5.1	19 E	EM	345 kPa, 50° Noz	O	87
5.1	24 E	EM	345 kPa, 50° Noz	o/c	82
5.1	25 E	EM	621 kPa, 50° Noz	C*	82
5.1	42 E	EM	621 kPa, 50° Noz	C*	62
5.1	45 C	EM	621 kPa, 100° Noz	C*	77
5.1	46 C	EM	621 kPa, 100° Noz	C*	85
5.1	52 C	EM	621 kPa, 100° Noz	C*	76
5.1	55 C	EM	621 kPa, 100° Noz	C*	83
15x46x2.5	13 E	BP	345 kPa, 100° Noz	o/c	19
15x46x2.5	14 E	EM	345 kPa, 100° Noz	o/c	10
15x15x2.5	21 E	EM	345 kPa, 50° Noz	o/c	75
15x30x2.5	22 E	EM	345 kPa, 50° Noz	o/c	57
15x46x2.5	26 E	EM	621 kPa, 50° Noz	o/c	81
15x30x2.5	47 C	EM	621 kPa, 100° Noz	C*	75
15x30x2.5	48 C	EM	621 kPa, 100° Noz	C*	72
15x30x2.5	50 C	EM	621 kPa, 100° Noz	C*	95
15x30x2.5	53 C	EM	621 kPa, 100° Noz	C*	88

Avg. % Recovery (EM only) = 76.7%
Std. Dev. (EM only) = 16.3

- E = Exploratory Test
- C = Confirmatory Test
- BP = Ignition source of 2 oz black powder + electric match
- EM = Ignition source of electric match only
- O = conveyor open at both ends
- o/c = conveyor open at detector end only
- C = conveyor totally closed
- C* = conveyor totally closed except for 20.3 cm bottom dump port

TABLE 3

RADFORD CONFIRMATORY SHOTS

SwRI Test No.	Propellant Layer	% Recovery	Response Times (sec)*	
			I-Detection	I-Water On
51	2.5 cm-M1 SP (19 kg)	71	.56	.62
54	2.5 cm-M1 SP (19 kg)	86	.70	.95
45	5.1 cm-M1 SP (38 kg)	77	.50	1.02
46	5.1 cm-M1 SP (38 kg)	85	.50	.58
52	5.1 cm-M1 SP (38 kg)	76	.48	.55
55	5.1 cm-M1 SP (38 kg)	83	.45	.55
47	15.2 cm x 38.1 cm x 25 cm M1 SP (28 kg)	75	1.02	1.16
48	15.2 cm x 38.1 cm x 25 cm M1 SP (28 kg)	72	0.6	1.55
50	15.2 cm x 38.1 cm x 25 cm M1 SP (28 kg)	95	.80	.80
53	15.2 cm x 38.1 cm x 25 cm M1 SP (28 kg)	88	.95	1.00
	Avg.	80.8%	0.71	0.88
	Std. Dev.	7.8%	0.29	0.31

Conveyor was closed except for bottom dump hole (20 cm diam.) at detector end.

Bottom ignition at 3.8 m from detectors.

Deluge: 4 each, S-1C-100-16 nozzles at 45°, yielded 301 L/m²

Maximum pressure rise = 28 kPa Maximum burn velocity = 4.3 m/sec

Time to Extinguish fires = 9-18 seconds.

*Reference discussion in Section II

generate an instant and intense fire within the propellant bed. In all cases, an Atlas electric match was used as the primary ignitor, and this in some instances was supplemented by a small bag containing black powder used to boost the electric match ignition into a full deflagration within the M-1 propellant. It was found very early in the testing that the black powder actually created a "mini explosion" at the ignition end of the conveyor and the resulting expanding gases forced the remaining unburned propellant all the way down the full length of the conveyor, such that all the burning occurred at the far end rather than along the full length of the tray. Consequently, for the balance of the tests only an electric match was used for ignition. This was found to be a more than adequate source with which to generate an almost instantaneous intense fire within the Radford conveyor.

Water Deluge System

One of the first concerns in the design of a water deluge system is the selection of an appropriate fire sensor with which to trigger that water deluge. The comparative evaluation of fire detectors as described in Appendix B of this report has indicated that the IR and visible detectors were incapable of seeing an M-1 propellant fire at the required conveyor length distance of 3.96 m. Nonetheless, through a series of 16 preliminary test firings, both an IR and UV detector were mounted side by side in the end of the conveyor and were wired such that the water deluge would trigger on an either/or basis. That is, the first detector which saw the fire would trigger the water deluge while simultaneously sending a signal to an oscilloscope for the recording of the relative response times of each of the detector instruments. In only two of these 16 tests did the IR detector function and only when the fire was triggered at distances of 1.8 or 2.7 m from the detector. At no time did the IR detector sense a fire at a distance of 3.96 m. Conversely, the UV detector sensed the fire on 15 of the 16 test firings and on this basis, the UV detector was judged to be the most reliable for use during the confirmatory test series.

Early in the testing a number of different nozzles were examined for possible use in the water deluge system, most of which were discarded because of their inability to provide a uniform coverage within the narrow confines of the Radford conveyor. Similarly, a few early experiments indicated that coverage in the amounts of 40.7-162.9 liters per minute per square meter would be unable to extinguish an M-1 propellant fire. With this basic information, the deluge system which was shown in Figures 1 and 2 was decided upon, and this system encompassed the use of either the 50° spray nozzles or the 100° spray nozzles (see Table 1 for details) and a static water supply pressure of 345 to 621 kPa. Upon examination

of the data shown in Table 2, it is apparent that there is no statistical difference between the percentage of recovery of M-1 propellant when either the 50° or 100° nozzles are used. Also, there does not appear to be any statistical difference between the percent recovery when operating with a static water pressure of either 621 kPa or 345 kPa. In keeping with the allowable water adequacy studies at the Radford AAP, and the knowledge that 621 kPa was the standard line pressure within the plant, 621 kPa was used for all of the so-called "confirmatory" tests. Since the 100° nozzles gave more uniform coverage than did the 50° nozzles, the 100° nozzles were used for the confirmatory test firings. In terms of water coverage, the 100° nozzles provided either 301 L/M/m² or 224 L/M/m² at 621 kPa and 345 kPa, respectively, while the 50° nozzle allowed 232 or 171 L/M/m² at 621 kPa and 345 kPa, respectively. Note that for the "confirmatory" tests using the 100° nozzles, the results showed 80.8 percent recovery, with a standard deviation of 7.8 (see Table 3).

Sequence Timing of Events

For all of the test firings, the sequence of events was timed both electronically and via the flashing of bulbs placed in view of the high speed camera coverage. These techniques were described in Section II. The response times of the events were then averaged for all of the confirmatory test firings and the results are reported in Table 3.

Pressure Rise and Burn Velocity

Using the techniques described in Section II of this report, the average burn velocity down the Radford conveyor tray was measured to be 137 cm/sec under the open conveyor condition and 350 cm/sec using a closed conveyor. The pressure rise within the open conveyor was recorded to be between 0 and 13 kPa, and the pressure rise for closed conveyor between 13 kPa and 27 kPa maximum. The calculated values varied from 6 kPa - 59 kPa, depending upon the vent area of the conveyor (see Appendix A).

Propellant Recovery

The total time from ignition to extinguishment for all the tests varies between 9 and 18 seconds. Examination of Tables 2 and 3 will reveal that the average percent recovery of the M-1 propellant from all the tests was 80.8 percent, and there seemed to be little difference between the percent recovery for each of the layer thicknesses tested. After every test, the recovered propellant was drained of water and weighed; then it was air dried for several days and the dry weight obtained. A comparison of these weights is shown in Table 4.

TABLE 4

MI-SP PROPELLANT RECOVERY
(Wet vs Dry Weight)

Test No.	Wet Weight (W) (kg)	Dry Weight (D) (kg)	Ratio W/D
2	21	15	1.35
4	10	8	1.35
5	10	7	1.37
6	10	6	1.61
11	20	16	1.22
12	24	18	1.35
13	10	8	1.39
14	5	4	1.5
17	53	32	1.64
18	54	36	1.47
19	58	38	1.52
21	31	19	1.64
22	25	15	1.61
23	34	20	1.74
24	50	36	1.38
25	45	36	1.23
26	37	30	1.22
47	33	21	1.58
48	28	20	1.38
50	34	28	1.21
51	23	14	1.70
52	47	29	1.63
53	30	25	1.22
54	25	16	1.5
Average W/D			= 1.45
Standard Deviation			= 0.17

CONCLUSIONS

1. The results of the tests on the Radford conveyor line indicated that a water deluge system designed to operate within the 62×10^4 Pa (90 psi) available water pressure will certainly act to extinguish a fire occurring with a conveyor.
2. It was also clearly shown that only a small pressure rise occurred as a result of a conveyor fire, and this pressure caused no deformation, rupture or explosion within the conveyor. The maximum pressure rise will be approximately 5.5×10^4 Pa (8 psi), hence the proposed pressure relief ports can be eliminated.
3. Following an extensive series of tests to evaluate the visible, IR and UV detectors, together with the simultaneous use of both IR and UV detectors viewing conveyor fires, it was found that the UV detector was the only reliable fire sensor for use in the 3.96 m long conveyor. The use of multiple IR detectors at short viewing distances will only add to the costs of the system.
4. The temperature rise in the environment surrounding the detector was found to be negligible; hence, no thermal damage would be done to the conveyor or the equipment operating that conveyor.
5. Using a four nozzle deluge system (S-1C-100-16 nozzles) operating at 62×10^4 Pa (90 psi) and yielding a total of 301.5 liters per minute per meter square (7.3 GPM/ft^2) activated by a UV detector, the response times of the deluge system were as follows:
 - Ignition to detector - 0.71 second
 - Ignition to primac valve - 0.78 second
 - Ignition to water on - 0.88 second
 - Ignition to full extinguishment - 9-18 seconds
6. As a measure of the effectiveness of the deluge system, an average of 80.8% of the original weight of M-1 propellant was recovered following the fire in the conveyor.
7. As a result of the effective use of a water deluge system, propagation of the fire down the conveyor and out the bottom exhaust port could be contained. The use of expensive fire gates at the Radford facility could be eliminated, thus resulting in a significant savings of money, both from the installation costs of the fire gates and the maintenance that would have been required.

RECOMMENDATIONS

Based upon the results of the test program to evaluate the effectiveness of a water deluge system in containing and extinguishing M-1 propellant conveyor fires and the conclusions drawn therefrom, the following recommendations are made:

1. Of the three fire detectors evaluated, having spectral response in either the visible, the IR or the UV range, only the UV detector was found to be reliable in its response to a fire at a distance of 3.96m down the conveyor. This detector should therefore be used.
2. Pressure rise in the conveyor will be minimal, hence the pressure relief ports can be eliminated.
3. Since the deluge system was demonstrated to be effective in extinguishing a fire, the use of fire gates between the cells at the Radford Ammunition Plant can be eliminated.
4. Under the most severe fire condition, originating at a point close to the intersection between two cells, momentary flame could be propagated into the next cell; hence, it is recommended that, through a selective triggering circuit between the detector and the primac valve, the water deluge system in the two adjacent cells be activated simultaneously with the activation of the water deluge system directly on the origin of the fire.

APPENDIX A
HAZARD ANALYSIS OF PRESSURE RISE

An important part of the research program was the analytical effort to study the pressure buildup as a result of burning large quantities of M-1 propellant and how this pressure buildup would be affected, should it be confined in a sealed or partially sealed conveyor. It is obvious that in any accidental propellant fire, some quantity of propellant will be burned before the detector can sense the fire and a water deluge system activated to extinguish that fire. The question then is asked, "How much propellant can one tolerate to be burned before secondary catastrophic events could occur, i.e., the rupture of a sealed conveyor, the possible blowoff of a frangible roof of the building, or the possible collapse of the building walls as a result of an internal pressure?" SwRI took several approaches to this descriptive analysis and these will be discussed.

Of interest was the peak static pressure that could develop in a plenum due to the accidental burning of a large quantity of propellant. The "plenums" of interest to this study were the Radford M-1 propellant conveyors which are 3.96m long x 30.48 cm wide x 15.24 cm high. The conveyor is closed with a lid which can, if necessary, be provided with blowout ports should a pressure buildup be suspected. For the SwRI experimental program, these pressure ports in the conveyor were not used, but the test conditions were: ends of the conveyor open, one end open-one end closed, and two ends closed. For the latter series of tests, Tests No. 40 and following, the conveyor was provided with a drop chute at one end of the conveyor simulating the part through which the propellant passes in leaving the vibrating conveyor line. It was also assumed that the ignition would always occur at a point far distant from any vent hole with the consequence that any pressure buildup had to travel down the closed conveyor before being vented through one of the ports.

Quick reference to the Handbook* revealed that M-1 propellant produces 858 ml/gm (14.3 ft³/lb) of gas when burned completely and after the gas has cooled to ambient temperature. This value can be increased by an order of magnitude if the gas is still contained within the "fire-ball" of still burning propellant at a temperature in excess of 2400 K. Consider for example the most severe case of all tests conducted. In Test No. 45 (see Table 3) 8.76 kg of M-1 at 180m³/kg = 76.6m³ of gas were generated in approximately 13 seconds prior to extinguishment. Without any venting this pressure rise could result in the explosive rupture of the conveyor.

* Properties of Explosives of Military Interest, AMCP 706-177, Engineering Design Handbook, Explosives Series, March 1967.

To examine this problem, SwRI referred to the Filler* method of calculating the peak static pressure resulting from the generation of a gas in a closed vessel. This method can be used when the gases generated are a small percentage of the gases in the vessel at the time of occurrence.

Filler derived the relationship in English units

$$P = \frac{H(r-1)}{V}$$

where

P = pressure rise

H = heat added to the gas

r = ratio of specific heats Cp/Cv

V = volume of the room

Using the specific heat ratio of 1.4 for air, the pressures being considered and conversion factors, this equation can be expressed as:

$$P = \frac{3844 Wh}{V}$$

where

P = pressure rise in psi

W = weight of propellant in lbs

h = heat of combustion in K cal/gr

V = volume in ft³

referring again to Test No. 45, i.e., 8.76 kgm (19.32 lb) of M-1 burned combustion of M-1.†

*Wm. S. Filler, "Fast Detonation Pressure & Thermal Studies of Solid High Explosives in a Closed Chamber", NAVORD Reports 2934 and 3890, Sixth Symposium on Combustion, Reinhold Publishers, Inc., N.Y. pp. 648-657.

† "Military Explosives", TM-9-1910, TO 11A-1-34, Table VIII.

$$P = \frac{3844 \times 19.32 \times 2.975}{6.5}$$

$$P = 3.4 \times 10^4 \text{ psi}$$

$$= 489 \times 10^4 \text{ psf}$$

$$= 2388 \times 10^4 \text{ kg/m}^2$$

Obviously these pressures would rupture the conveyor. More realistically, however, the conveyors are vented and this case is now considered. Since the conveyor resembles a pipe configuration, reference was made to the work of Rouse & Howe* and the equation used to calculate pressure rise in the conveyor was then derived:

$$\Delta P = \frac{Pv^2}{2} + \frac{Pv^2 FL}{2D}$$

where

$$P = \text{density of the gas, } \left(\frac{.0025085 \text{ lb} \cdot \text{sec}^2}{\text{ft}^4} \right)$$

$$v = \frac{Q}{A} \quad Q = \text{volumetric flow rate in ft}^3/\text{sec}$$

$$A = \text{vent area in ft}^2$$

L = length of conveyor in ft

D = diameter of equivalent pipe (needed in calculating Reynolds No.)

F = friction factor (F = 0.03, based on Reynold's No. of 1×10^{-6} and a relative roughness (D/K) of 223),

and P = pressure rise in psi

This equation was used to consider three cases based upon actual Radford test firings conducted by SwRI. In the first case, SwRI Test No. 18, a 5.08 cm bed of propellant was burned and the fire was extinguished after burning a total of 7.26 kg of propellant. In the second case, SwRI

* H. Rouse & J. W. Howe, "Basic Mechanical of Fluids", John Wiley & Son, 1953.

Test No. 23, a 2.5 cm bed of propellant was burned and the fire was extinguished after having burned a total of 2.27 kg of propellant. The third case was SwRI Test No. 48, a 15.2 x 30.5 x 2.5 cm buildup in which the fire was extinguished in 9.3 sec after burning 7.75 kg of M-1.

The above three cases were then applied to each of five different vent hole configurations as are shown in Figure A-1. The results of the calculations indicate the obvious - the greater the vent area, the less will be the pressure rise within the conveyor. For the case where both end ports were open, plus the bottom slot, the pressure rise was less than 6.9kPa. Conversely, for the case where only one port was open and the bottom slot and second port closed, the pressure averaged a maximum of almost 41.4kPa. It should be pointed out that these calculations agree very well with the 13.8-27.6kPa which were actually measured in the early test firings.

Particular attention is called to the boxed square points on the curves of Figure A-1. These points correspond to the vent area configuration used in all of the "Confirmatory Tests" (See Table 3). When the in-plant conveyor is closed, with the only vent being the 20.3 cm meter exit hole in the bottom, the calculated pressure rise varies from 14.5kPa for a 2.27 kg burn to 59.3kPa for the worst case 7.75 kg burn.

These pressure rises would not and in actual test, did not, cause either deformation or rupture of the conveyor.

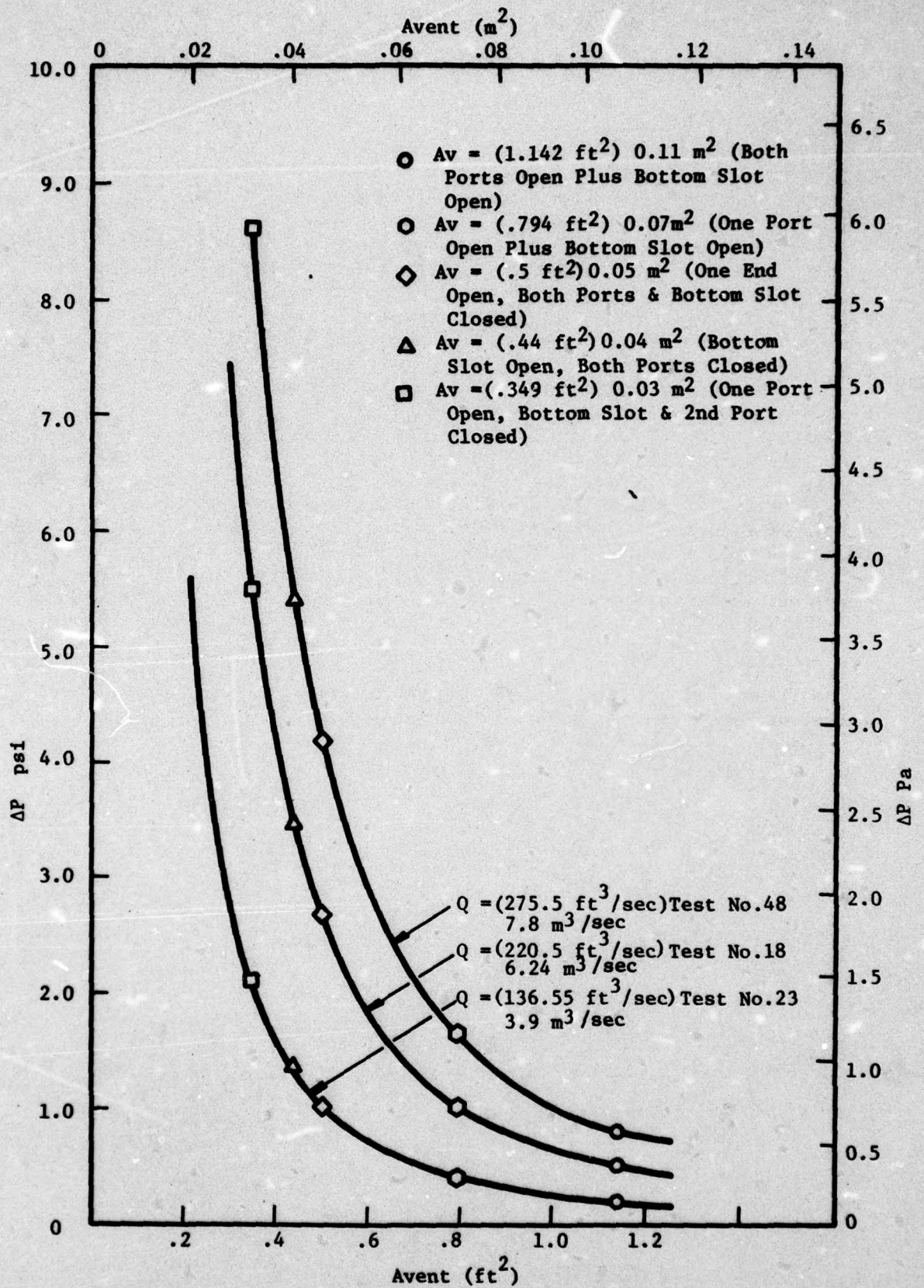

FIGURE A-1. PRESSURE RISE IN CONVEYOR VS VENT AREA

**APPENDIX B
COMPARATIVE EVALUATION OF FIRE DETECTORS**

In order for a deluge system to extinguish a fire on a processing line in an explosives or propellant handling facility, the system must have a sensor which will detect the fire and a control system which will activate a water valve within milliseconds of the fire appearing in the view of the detector. The detector cannot normally be located physically near the most probable point where fire could occur. Therefore the sensor must be capable of detecting a fire at a distance of up to 6.1 m. Usually there is some solvent, including water, present during the handling processes, or dust is created, or the fire may be obscured by smoke. The sensor must be able to detect a fire through such atmospheres. Finally the sensor must not give false alarms, as for example when sunlight or incandescent or fluorescent lights suddenly appear in the view of the sensor. Such false alarms would result in stoppage of the processing line and in undue loss of the explosive being processed. The potential sources of the fire are the explosives or propellants being processed, both low and high explosives, the solvents being used in the processes and other combustible materials which could be present.

To detect and cause a reaction to a fire, there are a variety of detectors available with a wide variation in spectral response and time of reaction. As an adjunct to the major program SwRI made a cursory survey of these available detectors and elected to evaluate three candidates.

The three detector systems evaluated are ones which have been selected for use in explosives handling facilities or were selected as a result of earlier programs. All three of the detector systems react to electromagnetic radiations emitted by the fire, or in short the flames, visible or invisible. These radiation sensitive detectors have the capability of sensing fire remotely and quickly, which the more commonly encountered household or industrial sensor systems do not. All three of these detector systems use, or can use, a relay to operate the water valve. Each of these detector systems uses a different band of radiation wave lengths in its operation as follows:

- Ultraviolet - Detronics, Inc., 1850-2450 Å
- Infrared - ADT Corp., 7000-28,000 Å
- Visible - Pyrotector 4000-8500 Å

The purpose of the program was to measure the reaction time of each of the three detectors responding to identical flame sources, and their capability to activate a Primac water deluge valve.

A test matrix was established to monitor the detector response at four different distances, and to monitor what effect three different dust, solvent, water, and smoke concentrations will have upon the detector ability to sense a fire. Hence, this test matrix would encompass $4 \times 3^4 = 324$ tests for each fire source. A total of seven fire sources were selected for evaluation, and these were selected to be representative of either propellants, high explosives or their commonly used solvents such as ethyl alcohol and ether. Thus, the total matrix encompassed 324 tests for each of seven sources for a total of 2268 shots. For redundancy, this number of tests could be multiplied by a factor of two or three shots each, depending upon the statistical reliability one might be interested in. The total number of tests, therefore, constitutes what might be considered an unreasonable number of tests. Consequently, SwRI approached the evaluation of the test matrix using a statistical technique commonly known as "Fractional Factorial Analysis".* The results of this statistical analysis led to the establishment of the test matrix shown in Table 5 which will be discussed in detail later.

The test program used the experimental setup as shown in Figure B-1. Within the test chamber a fire was started at one end and the radiation was shielded from the detectors by a window which, when opened, would expose the flame source to the detectors which were mounted at the far end of the conveyor. The distance between the flame source and the detectors was varied, as was the ambient atmosphere between flame and detectors. As shown in the schematic drawing, the signal from each of the three detectors was transmitted back through an amplifier, a switch and a relay and the response of the detectors was displayed on an oscilloscope. The output signal from the relay was used to trigger a flashbulb which was indicative that a signal had been sent to a Primac water deluge valve. Each of the three oscilloscope traces were started when the window was opened. Hence, the response time of each detector was recorded and the comparative response times between the three detectors was similarly displayed on the same oscilloscope record. The response of each of the detectors, as a function of the variables within the test matrix, is reported.

Displayed in Table 5 are the response times for the three detectors when they were exposed to seven different fire sources. In column 2 of Table , it can be seen that each flame source was placed at a distance of 3.7, 2.7, 1.8 or 0.9 m from the detectors, and the re-

* Owen L. Davies, "Design and Analysis of Industrial Experiments," Hafner Pub. Co., 1967.

TABLE 5

MEAN RESPONSE TIME OF EACH DETECTOR FOR
DISTANCE AND ATMOSPHERE

To Detect Fire of	At Distance (m)	Response in seconds through														
		Air				Black Powder Smoke				Dust (AC Fine)				Acetone		
		N	UV	IR	V	N	UV	IR	V	N	UV	IR	V	N	UV	
Ni Propellant	3.7	8/5	.08	.29	.24	1	.12	NR	NR	1	NR	NR	NR	3	.15	.04
	2.7	2	.08	.21	.22	2	.06/NR	.12/NR	.10/NR	1	.23	NR	.50	1	.12	.04
	1.8	1	.05	.08	.07	1	NR	NR	NR	4/3	.10/NR	.31/NR	.14/NR	1	.04	.04
	.9	1	.02	.05	.05	1	.09	.24	.10	1/0	.08	.06	-			
WC 870	3.7	2/1	.15	NR	.25	1	NR	NR	NR	1	NR	NR	NR	1	.10	.04
	2.7	4/3	.07	1.46/NR	.07	1	NR	NR	NR	2	.10	NR	.18	1	.10	.04
	1.8	1	.04	.20	.03	1	.22	NR	.10	1/0	NR	NR	-	1	.06	.04
	.9	1	.04	.08	.03				.03	1/0	.16	NR	-			
Ethyl Alcohol	3.7	2/1	.22	NR	NR					1	NR	NR	NR	1	1.47	.04
	2.7	2/1	.15	NR	NR					1	NR	NR	NR	1	.25	.04
	1.8	2/1	.08	NR	NR	1	NR	NR	NR	2/0	1.14	NR	-	1	.07	.04
	.9	2/1	.05	NR	NR	1	NR	NR	NR					1	.05	.04
Ether	3.7	2/1	.14	NR	NR					1	3.77	NR	NR	1	.69	.04
	2.7	2/1	.08	NR	NR									1	.12	.04
	1.8	2/1	.05	1.36/NR	NR					1/0	.36	NR	-	1	.07	.04
	.9	2/1	.04	.23	NR	1	.07	2.59	NR	1/0				1	.05	.16
Composition B	3.7	3	.10	.34/NR	2.25	1/0	NR	NR	-	2	NR	NR	NR	1	1.08	.04
	2.7	2	.17	.48	8.94/NR					1/0	NR	NR	NR	4	.58	.04
	1.8	1	.10	.24	.83					1/0	NR	NR	-	1	.05	.25
	.9	1	.03	.03	.04	1/0	.18	NR	-	1/0	.15	1.38	-			
Composition C4	3.7	1	.18	NR	NR	1/0	NR	NR	-	2	.72	NR	NR	1	.54	.04
	2.7	1	.11	NR	NR									1	.13	.04
	1.8	1	.05	NR	NR					1/0	.20	NR	-	1	.05	.04
	.9	3	.03	NR	NR	1/0	NR	NR	-	1/0				1	.01	.04
Black Powder	3.7	2/1	NR	.06	.04	1	NR	NR	NR	1	NR	NR	NR	1	NR	.04
	2.7	2/1	NR	.05	.04					1	NR	NR	.07	2	NR	.04
	1.8	1	NR	.06	.05	1	NR	NR	NR	1	NR	NR		1	NR	.10
	.9	1	.16	.07	.06	1	NR	.08	.06	1/0	NR	.11	-	1	.10	.10

Note: The sample size N, is given for all sets of data. In several of the tests, data were obtained from the UV and IR detectors only; therefore, when two values of N are given, the value to the left of the slash is for the UV and IR detectors and the value to the right for the V detector.

.09	1/0	.05	NR	-	1	.05	NR
.06	1	.75	NR	.05	1	.05	.36
.07	1	.04	.37	.04	1	.03	.11
NR	1	1.09	NR	NR	1	.34	NR
NR	1	.36	NR	NR	1	.17	NR
NR	1	.07	NR	NR	1	.07	NR
NR	1	.05	NR	NR	1	.05	NR
NR	1	.20	NR	NR	1	.10	NR
NR	1	.07	NR	NR	1	.09	NR
1.20	1	.07	NR	NR	1	.05	NR
NR	1	.05	.37	2.22	1	.05	1.11
NR	2	.28	.50/NR	2.24	1	.20	NR
.10	2	1.59	.27/NR	.28/NR	2	.13	.32/NR
.12	2	.11	.11/NR	1.03	1	.15	.20
NR	1	.10	.79	2.36			
NR	1	.15	NR	NR	1	.12	NR
NR	2	.24	NR	NR	1	.07	NR
NR	1	.05	NR	NR	1	.05	NR
NR	1	.03	NR	NR	2	.04	NR
07	2/1	NR	.08	.05	2/1	NR	.09
07	1/0	NR			1/0	NR	.06
05	1/0	NR			1/0	NR	.05
04	1	.11	.06	.05	1	.08	.05

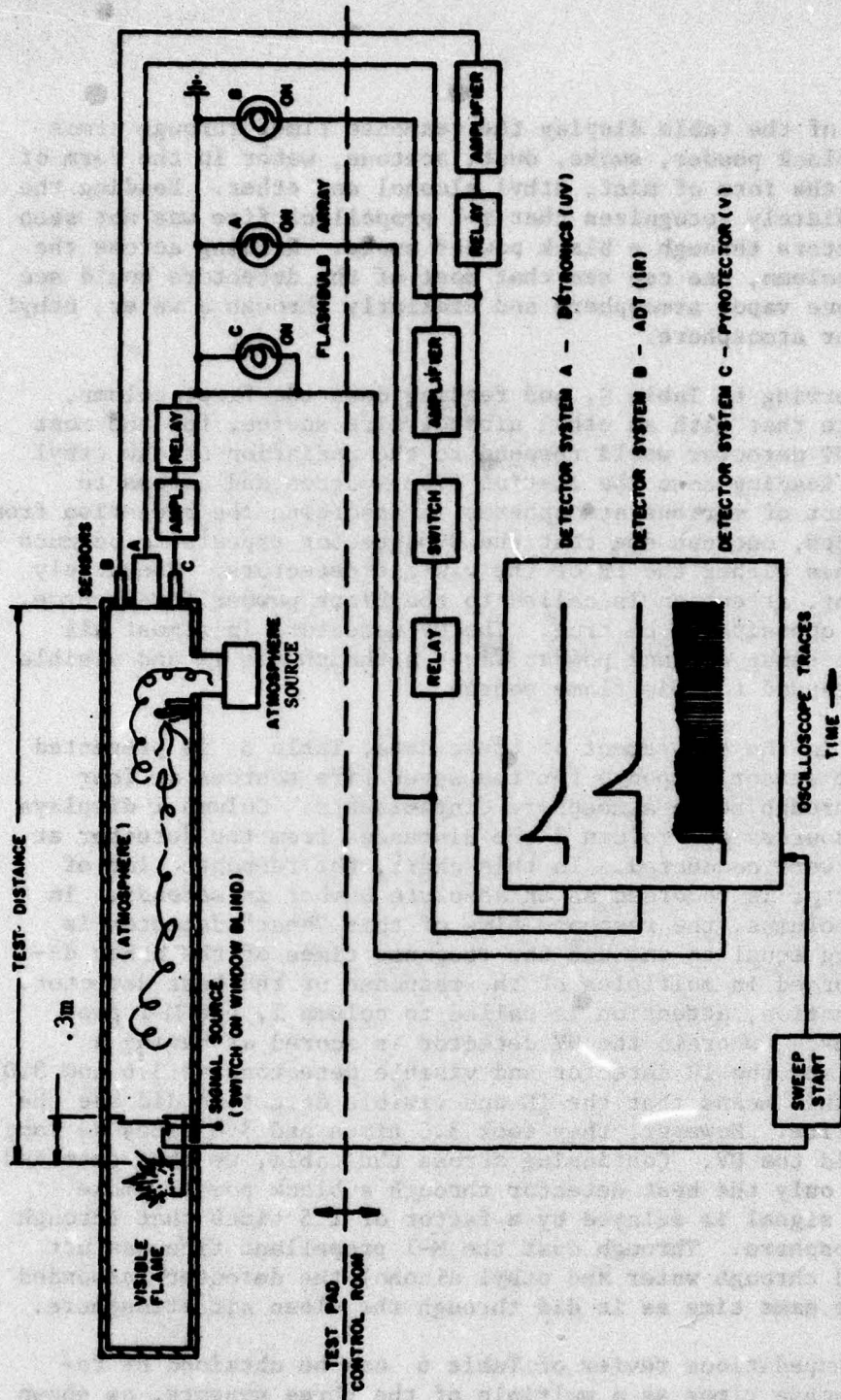

FIGURE B-1. Schematic of Detector Evaluation Test Chamber

maining columns of the table display the response times through atmospheres of air, black powder, smoke, dust, acetone, water in the form of steam, water in the form of mist, ethyl alcohol and ether. Reading the table, one immediately recognizes that M-1 propellant fire was not seen by several detectors through a black powder smoke. Reading across the M-1 propellant column, one can see that most of the detectors could see through an acetone vapor atmosphere and similarly through a water, ethyl alcohol and ether atmosphere.

Still referring to Table 5, and reading down the first column, the data indicate that with an ethyl alcohol fire source, for the most part, only the UV detector would respond to the radiation of the ethyl alcohol flame. Reading down the list of fire sources and across to observe the effect of various atmospheres in absorbing the radiation from those fire sources, one can see that the UV detector appears to be much more reliable than either the IR or the visible detectors. Conversely to this statement, attention is called to the black powder fire source. Here we see the opposite to be true. The UV detector, in almost all cases, would not sense a black powder fire, although the IR and visible detectors did respond to this flame source.

To assist in the assessment of these data, Table 6 is presented to summarize the sensor response for the seven fire sources at four distances and through seven atmosphere contaminants. Column 1 displays the seven fire sources and column 2 the distances from the detector at which the tests were conducted. In this chart, the response time of the "best" detector is recorded as an absolute number in seconds. In the next three columns, the response time of this "best" detector is recorded as being equal to one and the response times of the other detectors are recorded in multiples of the response of the best detector. By way of explanation, attention is called to column 1, the M-1 propellant fire source, wherein the UV detector is scored as having a response of one and the IR detector and visible detectors as 3.6 and 3.0, respectively. This means that the IR and visible detectors did see the M-1 propellant fire. However, they took 3.6 times and 3.0 times as long to respond as did the UV. Continuing across the table, we then examined the response of only the best detector through a black powder smoke atmosphere, the signal is delayed by a factor of 1.5 times that through a clean air atmosphere. Through dust the M-1 propellant fire was not seen at all, and through water and ethyl alcohol the detector responded at nominally the same time as it did through the clean air atmosphere.

The most expeditious review of Table 6 can be obtained by reviewing the response times as a multiple of the three sensors, as shown in columns 4, 5 and 6 of the table. Here one can readily see that the UV detector responded well for all of the flame sources with the exception of the black powder. Reviewing column 5 for the response of the IR detector, one can see that the IR was incapable of seeing an ethyl

TABLE 6

Summary of Sensor Response Data for Seven Fire Sources, Four Distances and Eight Atmosphere Contaminants

To Detect Fire Of	At Distance (m)	Response Time of Best (sec)	Response Time Multiple of Sensors (Time Best / Time Sensor)			Black Powder Smoke	Dist. (Stems)	MSE (Min)	Alcohol	Soot	Acetone
			UV	IR	V						
M Propellant	3.7	.08	1	3.6	3.0	1.5	-	1	1	1.5	1.9
	2.7	.08	1	2.6	2.6	1.0	2.9	1	1	1	1.5
	1.8	.05	1	1.6	1.4	-	2.0	1.2	1	1	1
	0.9	.02	1	2.5	2.5	4.5	4	-	-	-	-
BC 670	3.7	.15	1	ND	1.7	-	-	1	1	1	1
	2.7	.07	1	ND	1	-	1.4	1	1	5.1	1.4
	1.8	.05	1.3	6.7	1	3.3	-	2.3	1	1	1.5
	0.9	.03	1.3	2.7	1	1	4	-	-	-	-
Ethyl Alcohol	3.7	.22	1	ND	ND	-	1.5	1.2	5.9	1.5	6.7
	2.7	.15	1	ND	ND	-	1	1.1	2.4	1.1	1.7
	1.8	.08	1	ND	ND	-	1	1	1	1	1
	0.9	.05	1	ND	ND	-	22.0	1.2	1	1	1
Ether	3.7	.14	1	ND	ND	-	1	1.1	1.4	1	4.9
	2.7	.08	1	ND	ND	47.1	1.1	2.3	1	1.1	1.5
	1.8	.05	1	ND	ND	-	1.8	1.4	1	1	1.4
	0.9	.04	1	5.6	ND	1.8	1.3	1.3	1.3	1.3	1.3
Composition B	3.7	.16	1	ND	22.5	-	2	1.5	2.8	2.8	10.3
	2.7	.17	1	2.6	ND	-	1	1	9.4	1	3.4
	1.8	.10	1	2.4	8.3	-	-	1	1.1	1.5	1
	0.9	.03	1	1	1.3	6.0	3	-	3.3	-	-
Composition C5	3.7	.18	1	ND	ND	-	1.2	1	1	1	3
	2.7	.11	1	ND	ND	-	6.5	2.8	2.2	1	1.2
	1.8	.05	1	ND	ND	-	6.7	1	1	1	1
	0.9	.03	1	ND	ND	-	-	1.4	1	1.3	1
Black Powder	3.7	.04	ND	1.5	1	-	3.3	1.8	1.3	1.8	2.5
	2.7	.04	ND	1.3	1	-	2.8	1.8	1.8	1.8	2.5
	1.8	.05	ND	1.2	1	-	1	1	1	1	2
	0.9	.06	2.7	1.2	1	1	2	1	1	1	1.7

alcohol and composition C-4 fire, and was only marginally responsive to the VC870 propellant, the Comp. B, and the ether flame sources. The IR detector did, however, respond to the black powder flame source. The response of the visible detector is seen in column 6. This detector performed best when viewing a black powder fire, but was incapable of seeing ethyl alcohol, ether, composition C-4, and only marginally responsive to a Composition B flame source. Other investigators* have reported that the UV detector can be used to view black powder fires, however, their fire "samples" were much larger fires. For instance, MRC Corporation agrees with our tests in that they, too, could not see a one square foot fire at any distance. Larger fires, 1.9 square meters and over, could be detected but only out to distances of 3.7 meters. Day and Zimmerman were able to detect very large black powder fires with a UV detector.

Conclusions - The most important conclusion to be gained from a survey of these data is the unquestionable fact that one must carefully consider the flame source and the distance to the detector in selecting the appropriate system for use in fire detection. It would appear that the UV detector, overall, is the best for use with most of the flame sources, and in most cases, the response time of the UV was shorter than for either the IR or the visible detectors. There are, however, notable exceptions, probably the most prominent being that the UV detector was incapable of seeing a small black powder flame source.

In conducting this comparative evaluation, it was realized that the number of variables were many, and that only a relatively few parameters could be addressed. These experiments, while yielding quantitative numerical results, are most valuable if used in a qualitative sense by recognizing how these tests were conducted and then relating these results to a particular plant environment and potential fire source.

* MRC Corporation, Report No. 653, June 5, 1974, and Day and Zimmerman Corp., GOCO Contractors at Lone Star AAP, private communication.

DISTRIBUTION LIST

Commander
U.S. Army Armament Research and
Development Command

ATTN: DRDAR-CG
DRDAR-LC
DRDAR-LCM
DRDAR-LCM-S (12)
DRDAR-SF
DRDAR-TSS (5)
DRDAR-LCU-P

Dover, NJ 07801

Commander
U.S. Army Materiel Development and
Readiness Command

ATTN: DRCDE
DRCIS-E
DRCPA-E
DRCPP-I
DRCDI
DRCSG-S

5001 Eisenhower Avenue
Alexandria, VA 22333

Commander
U.S. Army Armament Materiel and
Readiness Command

ATTN: DRSAR-IR (2)
DRSAR-IRC
DRSAR-ISE (2)
DRSAR-IRC-E
DRSAR-PDM
DRSAR-LC (2)
DRSAR-ASF (2)
DRSAR-SF (3)

Rock Island, IL 61299

Commander
USDRC Installations and Services Agency
ATTN: DRCIS-RI-IU
DRCIS-RI-IC
Rock Island, IL 61299

Chairman
Dept of Defense Explosives Safety Board
Hoffman Bldg 1, Room 856C
2461 Eisenhower Avenue
Alexandria, VA 22331

Project Manager for Munition Production
Base Modernization and Expansion
U.S. Army Materiel Development and
Readiness Command
ATTN: DRCPM-PBM-LA
DRCPM-PBM-T-SF
DRCPM-PBM-EP (2)
Dover, NJ 07801

Director
Ballistic Research Laboratory
ARRADCOM
ATTN: DRDAR-BLE (C. Kingery) (2)
Aberdeen Proving Ground, MD 21010

Defense Documentation Center (12)
Cameron Station
Alexandria, VA 22314

Commander
U.S. Army Construction Engineering
Research Laboratory
ATTN: DERL-ER
Champaign, IL 61820

Office, Chief of Engineers
ATTN: DAEN-MCZ-E
Washington, DC 20314

Commander
U.S. Army Armament Research and
Development Command
ATTN: DRDAR-CC
DRDAR-LC
DRDAR-LCM
DRDAR-LCM-2 (W)
DRDAR-SF
DRDAR-TSS-12
DRDAR-LCU-9
Dover, NJ 07801

Commander
U.S. Army Materiel Development and
Readiness Command
ATTN: DRDE
DRCIS-E
DRCPA-E
DRCPM-I
DRCDI
DRCSO-2
2461 Eisenhower Avenue
Alexandria, VA 22331

Commander
U.S. Army Armament Materiel and
Readiness Command
ATTN: DRDAR-R (2)
DRDAR-RS
DRDAR-RSE (2)
DRDAR-RSE
DRDAR-RM
DRDAR-LC (2)
DRDAR-ASE
DRDAR-SF (2)
Rock Island, IL 61299

U.S. Army Engineer District, Huntsville
ATTN: Construction Division-HAD-ED (2)
P.O. Box 1600 West Station
Huntsville, AL 35807

Commander
Indiana Army Ammunition Plant
ATTN: SARIN-OR (2)
SARIN-SF
Charlestown, IN 47111

Commander
Kansas Army Ammunition Plant
ATTN: SARKA-CE
Parsons, KS 67537

Commander
Lone Star Army Ammunition Plant
ATTN: SARLS-IE
Texarkana, TX 57701

Commander
Milan Army Ammunition Plant
ATTN: SARMI-S
Milan, TN 38358

Commander
Radford Army Ammunition Plant
ATTN: SARRA-IE (2)
Radford, VA 24141

Commander
Badger Army Ammunition Plant
ATTN: SARBA (2)
Baraboo, WI 53913

Commander
Holston Army Ammunition Plant
ATTN: SARHO-E
Kingsport, TN 37662

Commander
Iowa Army Ammunition Plant
ATTN: SARJO-A
Middletown, IA 52638

Commander
Joliet Army Ammunition Plant
ATTN: SARJO-SS-E
Joliet, IL 60436

Commander
Longhorn Army Ammunition Plant
ATTN: SARLO-O
Marshall, TX 75670

Commander
Louisiana Army Ammunition Plant
ATTN: SARLA-S
Shreveport, LA 71102

Commander
Newport Army Ammunition Plant
ATTN: SARNE-S
Milan, TN 38358

Commander
Pine Bluff Arsenal
ATTN: SARPB-ETA
Pine Bluff, AR 71601

Commander
Sunflower Ammunition Plant
ATTN: SARSU-O
Lawrence, KS 66044

Commander
Volunteer Army Ammunition Plant
ATTN: SARVO-T
Chattanooga, TN 37401

Southwest Research Institute
ATTN: Mr. J. W. Gehring (10)
6220 Culebra Road
San Antonio, TX 78284

Weapon System Concept Team/CSL
ATTN: DRDAR-ACW
Aberdeen Proving Ground, MD 21010

Technical Library
ATTN: DRDAR-CLJ-L
Aberdeen Proving Ground, MD 21010

Technical Library
ATTN: DRDAR-TSB-S
Aberdeen Proving Ground, MD 21005

Benet Weapons Laboratory
Technical Library
ATTN: DRDAR-LCB-TL
Watervliet, NY 12189

Commander
U.S. Army Armament Materiel
Readiness Command
ATTN: DRSAR-LEP-L
Rock Island, IL 61299

U.S. Army Materiel Systems Analysis Activity
ATTN: DRXSY-MP
Aberdeen Proving Ground, MD 21005

46