

AD-A062 397

ANALYTICS INC WILLOW GROVE PA  
BREADBOARD DROPSONDE-MINIREFRACTIONSONDE ANALYZER. VOLUME 1.(U)  
NOV 78 M C WERST

F/G 4/1

N62269-77-C-0095

UNCLASSIFIED

NADC-76335-30

NL

1 OF 3  
ADA  
062397



DA  
239

AD A062397

(12)

LEVEL II  
SC



DDC FILE COPY

DDC  
RECEIVED  
DEC 19 1978  
RECEIVED  
F

This document has been approved  
for public release and sale; its  
distribution is unlimited.



ANALYTICS

## **DISCLAIMER NOTICE**

**THIS DOCUMENT IS BEST QUALITY  
PRACTICABLE. THE COPY FURNISHED  
TO DDC CONTAINED A SIGNIFICANT  
NUMBER OF PAGES WHICH DO NOT  
REPRODUCE LEGIBLY.**

Report NADC -76335-30  
Contract N62269-77-C-0095

12

DDC FILE COPY AD A0 62397

BREADBOARD DROPSONDE -  
MINIREFRACTIONS SONDE  
ANALYZER  
VOLUME I

DDC  
RECEIVED  
DEC 19 1978  
F

Mervin C. Worst

Analytix  
2500 Maryland Road  
Willow Grove, PA 19090

22 November 1978

Final Report for Period  
23 December 1976 - 22 November 1978

Approved for public release;  
distribution unlimited.

Prepared for:  
Sensors and Avionics Technology Department, Code 3044  
Naval Air Development Center  
Warminster, PA 18974

ANALYTICS

2500 MARYLAND RD., WILLOW GROVE, PA. 19090

78 12 13 061



Unclassified

(9) Final rept. 23 Dec 76-22 Nov 78

SECURITY CLASSIFICATION OF THIS PAGE (When Data Entered)

19 REPORT DOCUMENTATION PAGE		READ INSTRUCTIONS BEFORE COMPLETING FORM
1. REPORT NUMBER (18) NADC-76335-30	2. GOVT ACCESSION NO.	3. RECIPIENT'S CATALOG NUMBER
4. TITLE (and Subtitle) (6) Breadboard Dropsonde-Minirefraktionsonde Analyzer, Volume 1.		5. TYPE OF REPORT & PERIOD COVERED Final Report 12/23/76 - 11/22/78
		6. PERFORMING ORG. REPORT NUMBER
7. AUTHOR(s) (10) Mervin C./Werst	8. CONTRACT OR GRANT NUMBER(s) (15) N62269-77-C-0095	
9. PERFORMING ORGANIZATION NAME AND ADDRESS Analytics 2500 Maryland Road Willow Grove, Pa. 19090 (16) W05341		10. PROGRAM ELEMENT, PROJECT, TASK AREA & WORK UNIT NUMBERS 63207N W05340000 RB301
11. CONTROLLING OFFICE NAME AND ADDRESS Naval Air Development Center Warminster, Pa. 18974		12. REPORT DATE (11) 22 November 1978
		13. NUMBER OF PAGES 383
14. MONITORING AGENCY NAME & ADDRESS (if different from Controlling Office) (17) W0534000		15. SECURITY CLASS. (of this report) Unclassified
		15a. DECLASSIFICATION/DOWNGRADING SCHEDULE
16. DISTRIBUTION STATEMENT (of this Report) Approved for public release; distribution unlimited. (12) 286p.		
17. DISTRIBUTION STATEMENT (of the abstract entered in Block 20, if different from Report)		
18. SUPPLEMENTARY NOTES		
19. KEY WORDS (Continue on reverse side if necessary and identify by block number) Atmospheric Soundings      Refractive Anomaly Detector Radio Propagation Anomalies      Propagation Duct Locator Atmospheric Refraction Analysis      Radio Surveillance Radio Refraction Analyzer      Surveillance Radar		
20. ABSTRACT (Continue on reverse side if necessary and identify by block number) A programmable atmospheric refraction analyzer has been assembled to aid development of dropsonde and minirefraktionsonde (miniaturized balloon-sonde) sensor systems for the Navy's Meteorological Measuring System (MMS). Its Tektronix 4051 Graphic Display Computing System with specially interfaced digitizing equipment acquires and stores sonde data in real-time. Its variety of outputs include traditional meteorological profiles and special radio refraction profiles for		

DD FORM 1 JAN 73 1473 EDITION OF 1 NOV 65 IS OBSOLETE

Unclassified

SECURITY CLASSIFICATION OF THIS PAGE (When Data Entered)

405 904

Jsu



## TABLE OF CONTENTS

1.	INTRODUCTION	
1.1	Background . . . . .	1-1
1.2	Purpose . . . . .	1-1
1.3	Report Organization . . . . .	1-2
2.	ANALYZER SYSTEM DESCRIPTION	
2.1	Components . . . . .	2-2
2.2	Special Equipment and Interfaces . . . . .	2-2
2.3	System Capacity . . . . .	2-6
2.4	Portability Features . . . . .	2-8
2.5	Program Organization and Operation . . . . .	2-8
3.	TECHNICAL DESIGN BASIS	
3.1	Calculation of Telemetered Resistance . . . . .	3-1
3.2	Calculate Thermistor's Apparent Temperature, $T_T$ . . . . .	3-1
3.3	Calculation of Apparent Relative Humidity, $H_H$ . . . . .	3-3
3.4	Calculate Air Temperature, $T_A$ . . . . .	3-5
3.5	Calculate Relative Humidity of the Air . . . . .	3-5
3.6	Calculate Pressure . . . . .	3-7
3.7	Calculate Saturated Water Vapor Pressure, $e_s$ . . . . .	3-7
3.8	Calculate Refractivity, $N$ . . . . .	3-9
3.9	Calculate and Classify Refractivity Gradient . . . . .	3-9
3.10	Determine Modified Refractivity, M-Units . . . . .	3-10
3.11	Determine Dew-Point Depression . . . . .	3-10
3.12	Calculate Absolute Humidity, HABS . . . . .	3-11
3.13	Calculate Thickness of Atmospheric Layer . . . . .	3-11
3.14	Reference, Temperature and Pressure Data Restoration . . . . .	3-12
3.15	Humidity Data Restoration . . . . .	3-12
3.16	Data Reduction . . . . .	3-13
3.17	Gap Processing . . . . .	3-15
3.18	Determination of Surface Parameters . . . . .	3-16
3.19	Three-Cycle Stack Operations . . . . .	3-18
3.20	Other Software Design Features . . . . .	3-19
4.	OPERATING INSTRUCTIONS	
4.1	Precautions . . . . .	4-1
4.2	Baroswitch Dropsonde Processing . . . . .	4-2
4.3	CAPS Dropsonde and Minirefractionsonde Processing . . . . .	4-5
5.	PROGRAM DOCUMENTATION	
5-1	Program Listings and Annotation . . . . .	5-1
5-2	Assignment of Variables . . . . .	5-2



TABLE OF CONTENTS (continued)

6. OPERATIONAL RECORDER-ANALYZER INVESTIGATIONS

6.1	Baroswitch Calibration Simplification . . . . .	6-1
6.2	Signal Conditioner-Decommutator Performance . . . . .	6-7
6.3	Data Smoothing and Reduction . . . . .	6-17
6.4	Humidity Calculation . . . . .	6-18
6.5	Synchronous Decommutation . . . . .	6-26
6.6	Operational Output . . . . .	6-27
6.7	Analysis Algorithm Improvements . . . . .	6-28
6.8	Special Topics . . . . .	6-28

7. CONCLUSIONS AND RECOMMENDATIONS

7.1	Analysis Techniques for Noise-Effects Reduction . . . . .	7-1
7.2	Analysis Techniques for Processing-Load Reduction . . . . .	7-3
7.3	Other Recommendations . . . . .	7-5

APPENDICES:

A.	Analysis Example for Baroswitch Dropsonde
B.	Analysis Example for CAPS Dropsonde
C.	Analysis Example for Minirefractionsonde
D.	Program Listing for Baroswitch Dropsonde Analysis
E.	Program Listing for CAPS Dropsonde Analysis
v. 1 v. 2 F.	Program Listing for Minirefractionsonde Analysis
G.	Baroswitch Calibration Redundancy Eliminator Program Listing
H.	Example of Program Output from Redundancy Eliminator
I.	Program Test Results
J.	First Data Run for Conditioner-Decommutator
K.	Second Data Run for Conditioner-Decommutator
L.	Third Data Run for Conditioner-Decommutator



## 1. INTRODUCTION

### 1.1 BACKGROUND

Early in the 1970s, the Navy's weather squadron (WP-3A aircraft) was scheduled to be dismantled as its supply of AN/AMT-6 dropsondes neared exhaustion. An improved dropsonde was put into development because the previous dropsonde was not completely satisfactory and there was a need for continuing measurements of increased accuracy, density, and frequency as outlined by the Advanced Development Objective of the Meteorological Measuring System.

The dropsonde development was undertaken by the Naval Air Development Center with the objective of achieving compatibility with the existing logistics and launch facilities for sonobuoys, while also achieving simpler dropsonde preparation procedures and automatic data reduction.

### 1.2 PURPOSE

This report documents work performed under contract N62269-77-C-0095. The contract was awarded by the Naval Air Development Center to Analytics on 23 December 1976 for the purpose of providing a Breadboard Dropsonde Analyzer in which automatic data reduction algorithms could be refined for the baroswitch pressure sensing dropsonde and with which the equipment under development could be evaluated. On 9 June 1977, the contract was augmented to include an investigation of techniques to simplify handling of baroswitch calibration data. Again, on 23 January 1978, the contract was augmented to include balloon-borne minirefractionsonde operations and continuous analog pressure sensing dropsonde operations in the breadboard and in addition, operations-related investigations to guide the development of the operational microprocessor-based recorder-analyzer.

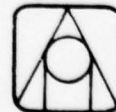

1.3 REPORT ORGANIZATION

This report is organized as an integrated report in compliance with the terms of the contract modification and covers all work performed under the contract as amended. This report therefore includes, in final form, all material that was published earlier in preliminary form under the contract.



## 2. ANALYZER SYSTEM DESCRIPTION

The Breadboard Dropsonde-Minirefractiosonde Analyzer can be used for analysis of three different types of soundings:

- (1) Dropsonde with baroswitch pressure sensor.
- (2) Dropsonde with continuous analog pressure sensor (CAPS).
- (3) Balloon-borne minirefractiosonde (with CAPS).

The equipment complement of the system is the same for analyzing all three types of soundings. The one exception is that the EECO Paper Tape Reader is not used in analyzing soundings using the CAPS dropsonde and the minirefractiosonde. The three types of analysis are accommodated by simply using a different program to control the processing.

The Breadboard Dropsonde-Minirefractiosonde Analyzer's design and development are based partially on principles that were implemented and shown feasible in the Engineering Prototype Processor that was developed by Analytics for NADC (Contract No. N62269-75-C-0382 -- Technical Report 1167, "An Engineering Prototype Processor Incorporating Data for Refractive Index Profiles").

Some departures from the Engineering Prototype Processor's software design were dictated by differences in system equipment complement and accompanying differences in performance capability. The analyzer design is based on a dedicated on-site processing system with tape files and graphic displays, whereas the earlier prototype processor used a non-dedicated remote system with drum files and without graphic displays. The system change was made to gain graphic display and cost advantages.



## 2.1 COMPONENTS

The Breadboard Dropsonde-Minirefractiionsonde Analyzer System is depicted in Figure 2-1. The system components are listed in Table 2-1.

## 2.2 SPECIAL EQUIPMENT AND INTERFACES

### 2.2.1 Signal Digitizing Counter

A Hewlett-Packard model 5328A/011 Universal Counter was selected to digitize the incoming signal periods for the following reasons:

- (1) It can perform all the necessary functions.
- (2) It is plug compatible with the Tektronix General Purpose Interface Bus (GPIB), and therefore requires no special interface design.
- (3) Its universal and programmable features make it a valuable addition to the 4051 system, permitting its use for a wide variety of counting, frequency measurement, and period measurement applications.
- (4) Its purchase and interface costs appeared less than any other alternative available at the time of selection.
- (5) It was available with timely delivery.

The real-time data acquisition by the 4051 was accomplished by reducing the amount of processing required with each measurement obtained from the HP counter. To effect this reduction, it was necessary to modify the HP counter's decimal point positioning. The modification consists of a simple switch installation in the counter, as shown in Figure 2-2.

When the switch is closed, the decimal point shifts four places to the left changing neither the contents of the display register nor the exponent. Thus, it effectively divides the displayed value by 10,000. This change permits the 4051 program to be simple and short with no operations having long execution time; it is thus capable of real-time acquisition, packing and internal storage.



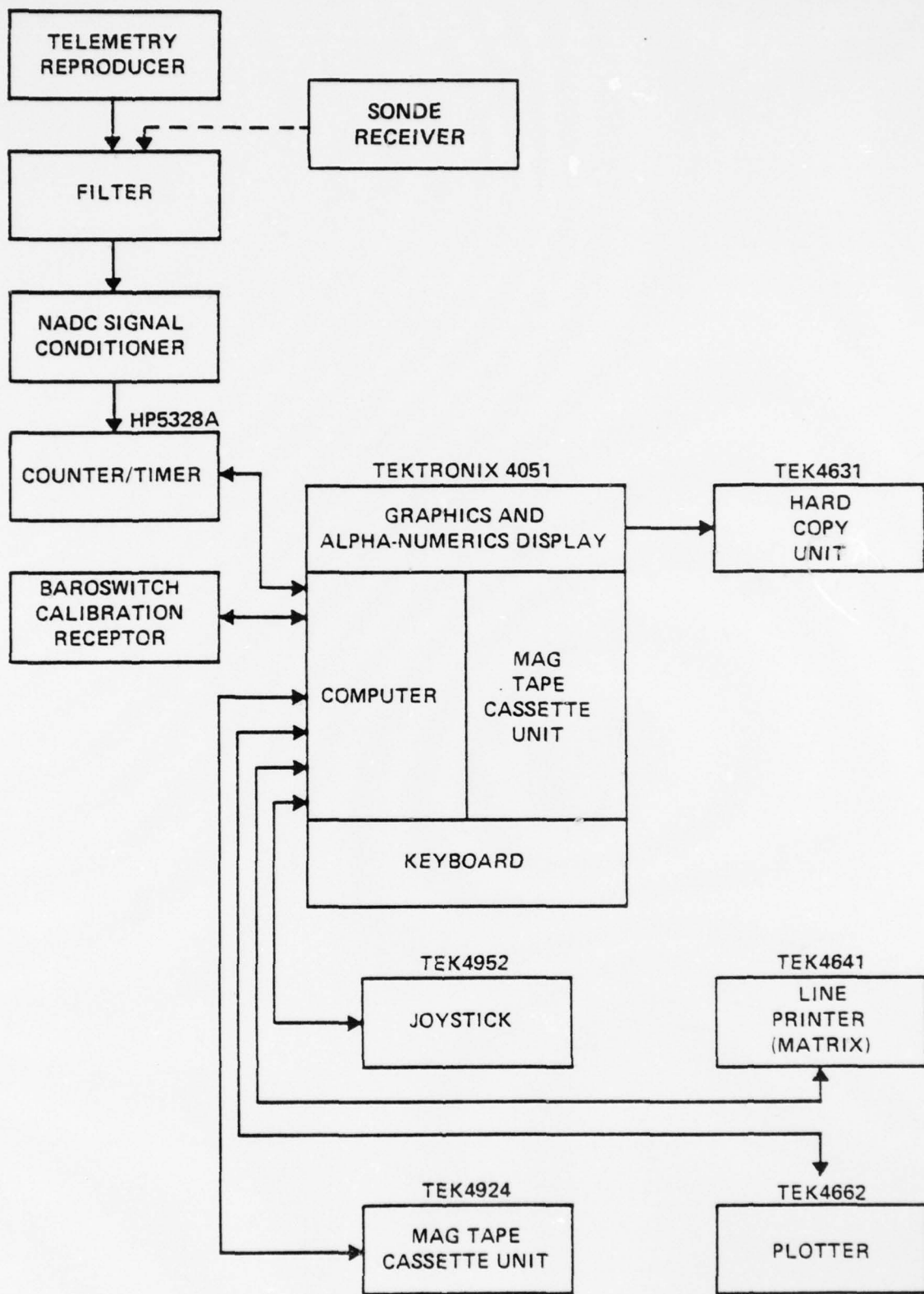

Figure 2-1. Breadboard Dropsonde Mini Refraction Sonde Analyzer Block Diagram



Table 2-1. Breadboard Dropsonde-Minirefraktionssonde Analyzer  
System Components List

BASIC Graphic Unit (Tektronix 4051; 32K Memory)  
Hard Copy Unit (Tektronix 4631)  
Interactive Plotter (Tektronix 4662)\*  
Line Printer (Tektronix 4641)  
Magnetic Cassette Drive (Tektronix 4924)\*  
Joy Stick (Tektronix 4952)\*  
Interconnecting cables for all above units  
Operating Manuals for Tektronix 4051  
System Cassettes for Tektronix 4051  
Data Storage Cassettes for Tektronix 4051  
Telemetry Tape Reproducer (Multispeed)  
NADC Conditioner for Reproduced Telemetry Signal  
Frequency Signals Receptor (HP5328A/011)  
Baroswitch Calibration Receptor (EECO Paper Tape Reader)\*\*  
Interface Electronics for EECO Reader\*\*  
High and Low Pass Electronic Filter

---

\*These units are available in the breadboard system although they have not been programmed into the three instant analysis cases for portability reasons.

\*\*The EECO paper reader is not used for analysis of CAPS dropsonde and CAPS minirefraktionssonde soundings.



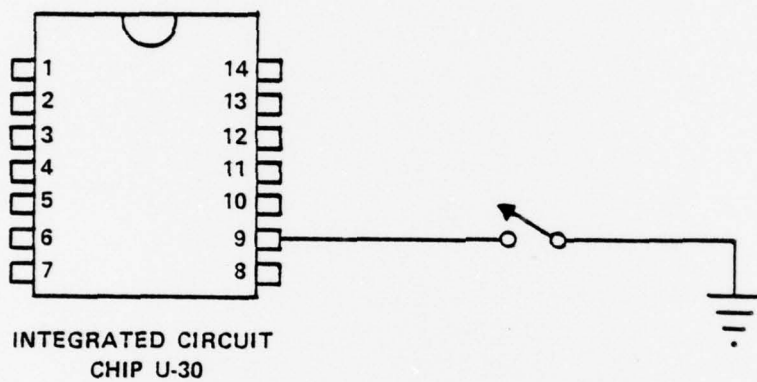

NOTE: SWITCH IS LOCATED UNDER TOP COVER OF COUNTER. WHEN IN CLOSED POSITION, IT MOVES THE DECIMAL POINT 4 PLACES TO THE LEFT, EFFECTIVELY DIVIDING THE DISPLAYED VALUE BY 10,000.

Figure 2-2. Decimal Point Position Modification in HP 4328A/011 Universal Counter



The counter can be restored easily to normal operation by removing the top cover and changing the switch position.

### 2.2.2 Calibration Tape Reader

An EECO Micromate paper tape reader was selected as the input device for calibration data for the baroswitches. The selection was based on the following considerations:

- (1) Excellent engineering design features show good prospects for high reliability, ruggedness, low tape wear, and data fidelity.
- (2) TTL interface employing voltage levels compatible with GPIB and thus permitting simplified interface.
- (3) Low cost.

The electrical interface is limited to hand-shaking operations, since the data levels were electrically compatible. The electrical interface circuitry is shown in Figure 2-3. It is assembled in a small module that plugs into and clips fast to the EECO connector. The GPIB cable from the 4051 then connects to the interface module.

A data inversion is necessary to complete the interface. This is accomplished by a software interface in the 4051, which uses the transparent READ BYTE statement to accept the byte regardless of data content. A 256-complement operation accomplishes the bit-by-bit inversion of the byte.

### 2.3 SYSTEM CAPACITY

The analyzer stores data in real-time as they are received from the magnetic tape reproducer (or from the sonde via telemetry). The sounding measurements are stored in approximately 30,000 bytes of memory using approximately five bytes per measurement. Thus, roughly 6,000 measurements are stored. At the nominal sampling rate of 10 measurements per second, this provides about 10 minutes of real-time data storage capacity for drop-soundings. The data acquisition and storage program for the balloon-borne



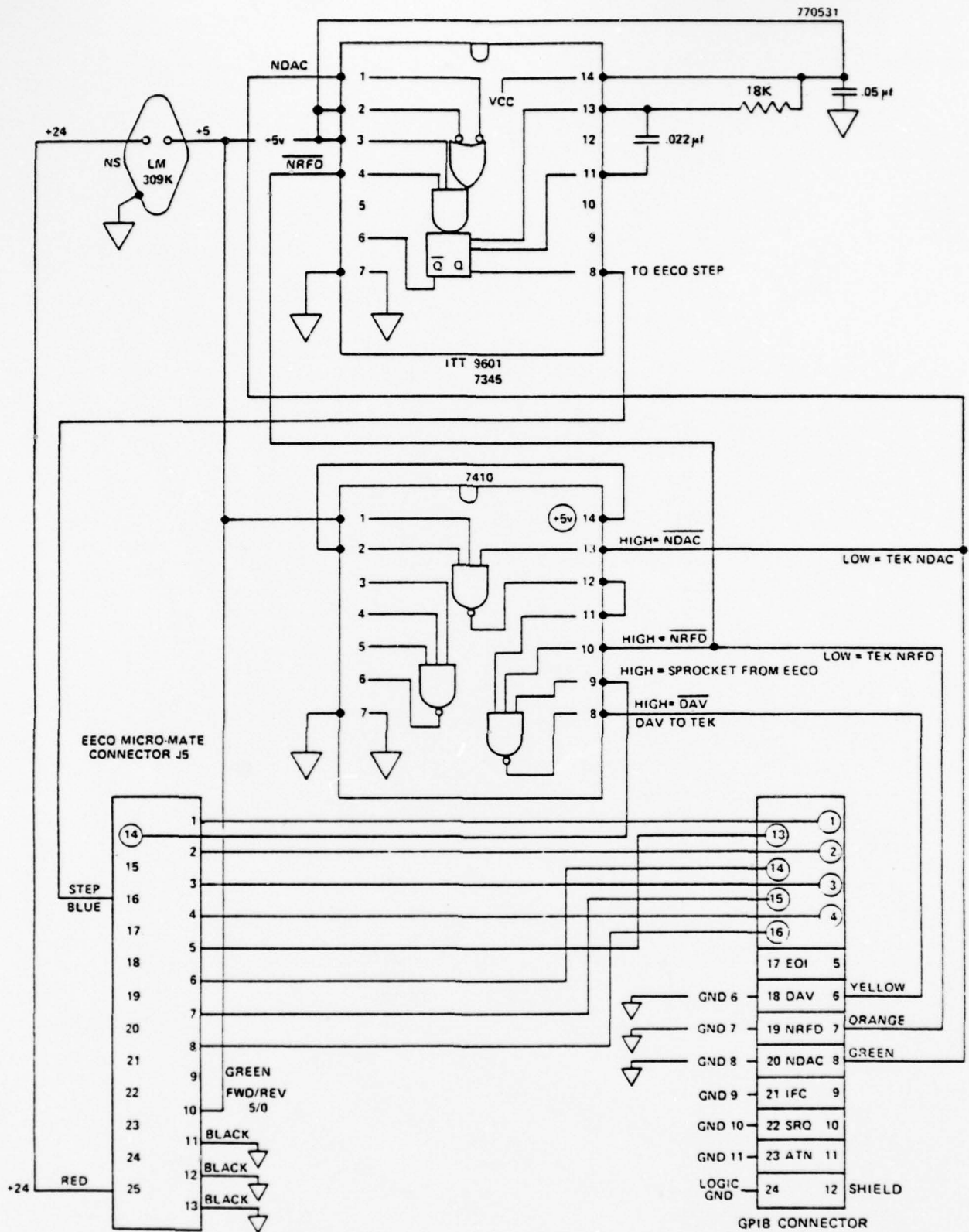

Figure 2-3. Interface Electronics for EECO Paper Tape Reader



minirefractionsonde stores only every third sample because the spatial sampling density is roughly three times as great. Thus, approximately 30 minutes of real-time data can be stored for a balloonsounding.

The system performs calculations with an accuracy that exceeds ten digits of precision. This permits algorithms to be evaluated for fidelity well beyond the three or four significant digits normally associated with the most accurate of meteorological soundings. It further assures that algorithms can be developed with such high accuracy that processing errors will be small relative to the overall system error.

#### 2.4 PORTABILITY FEATURES

The Tektronix 4051 Graphic System used to implement the analyzer includes a remote magnetic tape cartridge unit, an X-Y plotter with joy stick, a high speed printer, and a hard copy unit in addition to the keyboard-display-tape unit housing the computer. However, the software has been organized so that soundings can be analyzed using only the keyboard-display-tape unit and the high speed printer. This permits easy transportation of the analyzer system to a test site for on-location analysis of the sounding data.

#### 2.5 PROGRAM ORGANIZATION AND OPERATION

The three analysis programs are stored on individual tape cassettes: Baroswitch Dropsonde on cassette V, CAPS Dropsonde on cassette IX, minirefractionsonde on cassette X. Each program cassette contains all the programs needed to run the complete analysis.

Programs for the three different types of soundings are organized similarly into four program files as follows:

<u>File No.</u>	<u>File Name</u>
1	Calibration-Acquisition
2	Reduced Data File Builder
3	Temp, Press., Hum. Table Builder
4	Output Report Generator



- (1) File 1 performs acquisition of calibration and signal data and files the data on a cassette.
- (2) File 2 converts the unabridged data file on tape into a reduced data file stored in internal memory. This data is then processed to eliminate incongruous samples.
- (3) File 3 calculates temperature, pressure, and humidity and in the case of the baroswitch dropsonde, performs sensor lag compensation.
- (4) File 4 calculates all other desired atmospheric parameters and reports these utilizing graphic displays and a printed output.

The first file automatically loads into the 4051 internal memory and executes when the AUTOLOAD key is depressed. This program immediately provides the operator with a selection of programs to be run. If calibration-acquisition is selected, the program remains resident and performs the selected functions. If analysis is selected, the program deletes the calibration and acquisition routines and appends the second file from the cassette, making the second program file resident in internal memory.

If calibration-acquisition (file 1) is selected, it begins with the construction of a calibration data file. Launch parameters and constants characteristic of individual sondes are entered here and are stored in a magnetic tape file. Then acquisition of raw data begins.

In the case of the dropsonde: every sample is collected and packaged two per word becoming integer first, then decimal. Next, the raw data are written into a magnetic tape file whose first entry indicates the number of samples contained in the file.

In the minirefractinsonde case: the same procedure is used as for the dropsonde with the following exceptions. Every third sample is collected; the data are packed into words in reverse order becoming first decimal and then integer; the packed words are written on magnetic tape also



in reverse order. Again, the first file entry indicates the number of samples contained in the file.

The effects of these variations is to make minirefractiionsonde data resemble the dropsonde's data so that analysis software differences can be minimized.

If analysis (file 2) is selected, it executes automatically and builds an internal file of reduced data representing the entire sounding. The reduced data file consists of time-tagged period ratios for temperature, pressure, and humidity. To build this reduced data file, the program performs synchronization, validation, and restoration of data in a three-cycle stack. The last operation in the stack is the conversion of the data into period ratios. At this point, the period ratios are reduced in the "significant period ratio" subroutine, and then the final operation in file 2, "Gap Processing" is performed. At the completion of program file 2, file 2 is deleted and file 3 is appended and executes automatically, with file 3 the only program resident in memory.

The third program is automatically executed and processes the internal file of reduced data to produce profiles in temperature, pressure, and humidity. In the case of the baroswitch dropsonde, file 3 also compensates for sensor lag. Before calculating the entire temperature, pressure, and humidity profile, however, the program allows the operator to see the three atmospheric parameters for any given time tag in order to check them for reasonability. As before, when program file 3 has been executed, it is deleted and file 4 is automatically appended, making it the only program resident in memory.

File 4 now performs the final processing and reporting. First, in order to build an altitude file, the program determines surface conditions of temperature, pressure, and humidity, and allows the operator to change these if desired. An altitude profile is now constructed, building



up from the surface, and is stored in an array along with the temperature pressure and humidity profiles. Refractivity in terms of N-units is also calculated and stored in the same array. All parameters other than those stored in the aforementioned array, however, are calculated each time they are used, due to lack of storage space. The following tabulation depicts the organization of the completed P-array in which the quantities mentioned above are stored from this point on in the program's execution. The P-array is dimensioned to 3 x 400.

N (Levels)	P(1,N)	P(2,N)	P(3,N)
1	Time-Tag.Temperature	Altitude.Pressure	Refractivity.Humidity
2	" "	" "	" "
3	" "	" "	" "
4	" "	" "	" "
.	" "	" "	" "
.	" "	" "	" "
T	" "	" "	" "
T+1	0	0	0
T+2	0	0	0
.	0	0	0
.	0	0	0
399	0	0	0
400	T	T	T

where T = number of levels declared significant in file 2  
 and temperature is stored in  $(\text{deg-c}/1000) + 0.1$   
 altitude is stored in feet x 100  
 pressure is stored in MB/10000  
 refractivity is stored in N-units x 1000  
 humidity is stored in %/1000



Note that the time-tag for a pressure (or humidity) value is the time-tag for the temperature value on the same level + 1(+2). Also note that the altitude and refractivity values refer to temperature, pressure and humidity values on the same level.

At this point, the program begins its reporting with the "Detailed List of Atmospheric Parameters" which is output on the high speed printer. This list contains for every cycle in the P-array, altitude (ft. and M), pressure (MB), temperature (deg-c), relative humidity (%), refractivity N- and M-units), saturated vapor pressure (MB), dew point depression, refractivity gradient, and refractivity gradient classification. When this list is completed, the reporting switches over to the CRT display where temperature, humidity, and refractivity in N-units and M-units are plotted against altitude and recorded by the hard copy unit.

Now the high speed printer is employed again to print out the list of "significant levels." This listing is of the same parameters printed out in the "detailed list," but only for those levels deemed "significant" by an algorithm similar to that used in file 2. Here, though, the fit is made to linear trends of temperature and humidity vs. altitude.

Finally, the last item reported is a third list of the same parameters. Here, though, the values are chosen for specified values of pressure. This printout is entitled "Mandatory Levels" and is the final function of the program.

It should be noted that there are several program monitoring outputs which appear on the CRT display during program execution. When the program has been validated against a sufficient number of soundings, these outputs may be eliminated.



### 3. TECHNICAL DESIGN BASIS

Important software design features for analyzing all three types of soundings are described in this section. Where differences exist among the sondes, they are identified and described. If no difference is noted, the feature applies to all three sondes. Some of these features are adaptations from the Engineering Prototype Processor.

#### 3.1 CALCULATION OF TELEMETERED RESISTANCE

##### 3.1.1 Baroswitch Dropsonde

The telemetered resistance, R, is calculated in kilohms using the equation,

$$R = 52.718 \frac{F_r}{F} - 47.718,$$

where  $F_r/F$  is the ratio of reference frequency to parameter frequency.

##### 3.1.2 CAPS Dropsonde and Minirefractiionsonde

Telemetered resistance is not calculated. The commutation technique makes it more convenient to calculate telemetered voltages which are included in calculations that follow.

#### 3.2 CALCULATE THERMISTOR'S APPARENT TEMPERATURE, $T_T$

First, the thermistor resistance,  $R_T$ , is set equal to the telemetered parameter resistance, R, expressed in kilohms.

$$R_T = R$$



Next, the thermistor resistance ratio,  $r_T$ , is determined using

$$r_T = \frac{R_T}{R_{TLI}}$$

where  $R_{TLI}$  equals thermistor lock-in resistance (kilohms). Then the thermistor's apparent temperature,  $T_T$ , is determined from

$$T_T = \frac{65.30}{1 - \sqrt{1 - 0.0480921 \ln \frac{r_T}{0.33785(10)^{-3}}}} - 273.16$$

which is the quadratic form of the thermistor characteristics equation developed by Analytics to replace the previously used thermistor calibration table with interpolation between table values.

### 3.2.2 CAPS Dropsonde and Minirefractionsonde

The apparent thermistor temperature is calculated for both CAPS-equipped sondes as described here. First, the thermistor's resistance ratio,  $r_T$ , is calculated using the following equation:

$$r_T = 22.1(1/(KR_T) - 1)/R_{TLI}$$

where:

- K = ratio of supply voltage to reference voltage, supplied with sonde
- $R_T$  = ratio of reference period to temperature period ( $R_T < 1$ )
- $R_{TLI}$  = thermistor lock-in resistance in kilohms.

Next, the apparent thermistor temperature,  $T_T$ , is calculated from the thermistor resistance ratio,  $r_T$ , using the equation in the last paragraph.



### 3.3 CALCULATION OF APPARENT RELATIVE HUMIDITY, $H_H$

#### 3.3.1 Baroswitch Dropsonde

First, the hygistor resistance,  $R_H$ , is calculated according to

$$R_H = \frac{(R - 7.1) (250)}{250 - (R - 7.1)}$$

Then the hygister ratio,  $r_H$ , is determined from

$$r_H = \frac{R_H}{R_{HLI}}$$

where  $R_{HLI}$  is the hygistor lock-in resistance.

Next, a two-dimensional interpolative procedure is utilized to obtain hygistor's apparent relative humidity,  $H_H$ , from the table of  $r_H$  values.

#### 3.3.2 CAPS Dropsonde and Minirefraktionssonde

(1) Relative Humidity Resistance -- The following relationship converts measured humidity period ratio to resistance value of the humidity element.

$$R_h = (-249(18.2 - K(18.2 + 7.15)) (P_r/P_h)) / (18.2 - K(18.2 + 7.15 + 249)(P_r/P_h))$$

where:

$R_h$  = calculated resistance of the humidity element in  
K ohms

$P_r/P_h$  = ratio of reference period to humidity period

$K$  = ratio of reference voltage to dropsonde sensor  
supply voltage,  $V_{cc}$  ( $K$  = constant supplied with  
dropsonde)



(2) Apparent Relative Humidity ( $H_H$ ) -- The apparent relative humidity is then calculated using the following set of algorithms:

for  $R_h$  equal to or greater than  $R_o$ ,

$$H_H = 33 + a (\ln((R_h/R_o)^b))^c$$

where:

$$a = .02T + 3.2$$

$$b = 15$$

$$c = .9 - (.001425T + .25) (\log(\log(R_h/R_o) + 1))^{1/3}$$

and for  $R_h$  less than  $R_o$ ,

$$H_H = 33 - a (\ln((R_o/R_h)^b))^c$$

where:

$$a = .02T + 3.2$$

$$b = 20$$

$$c = .9 - (.001425T + .25) (\log(\log(R_o/R_h) + 1))^{1/3}$$

In the foregoing algorithm,

$H_H$  = calculated apparent relative humidity in percent

$T$  = air temperature in  $^{\circ}C$

$R_h$  = calculated resistance of the humidity element  
in K ohms

$R_o$  = humidity element "lock-in" resistance in  
K ohms ( $R_o$  = constant supplied with dropsonde)

$\ln$  = natural logarithm (base e)

$\log$  = logarithm to base ten



3.4 CALCULATE AIR TEMPERATURE,  $T_A$

3.4.1 Baroswitch and CAPS Dropsondes

$$T_A = T_T + L_T \frac{dT_T}{dt}$$

$T_T$  = thermistor's apparent temperature

$L_T$  = thermistor's lag coefficient

$t$  = time (sec)

3.4.2 Minirefractionsonde

$T_A$  is assumed equal to  $T_T$  due to low velocity of balloon sounding.

3.5 CALCULATE RELATIVE HUMIDITY OF THE AIR

3.5.1 Baroswitch and CAPS Dropsondes

First, determine  $H_H$  rate of change,  $dH_H/dt$ :

$$\frac{dH_H}{dt} = \frac{H_{H_i} - H_{H_{i-1}}}{t_i - t_{i-1}} = \dot{H}_H$$

if  $\dot{H}_H > 0$ , then  $K_1 = 0.17$ ;  $K_2 = 0.36$ ;  $K_3 = 17$ .

if  $\dot{H}_H < 0$ , then  $K_1 = 0.2$ ;  $K_2 = 0.75$ ;  $K_3 = 19.3$ .

If  $\dot{H}_H = 0$ , do not apply lag compensation. To apply lag compensation ( $\dot{H}_H \neq 0$ ), calculate the hygistor lag coefficient,  $L_H$ , as follows:

$$L_H = K_1 \left( \frac{273.16}{T_A + 273.16} \right) + K_2 \left( \frac{273.16}{T_A + 273.16} \right)^{K_3}$$



Finally, calculate the relative humidity of the air,  $H_A$ .

$$H_A = H_H + L_H \frac{dH_H}{dt}$$

### 3.5.2 Minirefractiionsonde

$H_A$  is assumed equal to  $H_H$  due to low velocity of balloon sounding.

## 3.6 CALCULATE PRESSURE

### 3.6.1 Baroswitch Dropsonde

Pressures for baroswitch dropsondings are calculated by first determining time-tags for baroswitch contact breaks, then establishing the contact numbers associated with the break time-tags and finally retrieving from the calibration table the pressures associated with each contact number's time-tag. From these retrieved pressure values, a table of time-tags with associated pressure is built.

Whenever pressure is needed in later processing, it is calculated for any desired time-tag by table look-up and linear interpolation of pressure between time-tags.

The most difficult part of this pressure calculation procedure is the automatic detection of contact breaks, which is illustrated by the flowchart in Figure 3-1. The flowchart illustrates contact break detection, although the program is organized in such a way that it can also be used for make detection.

### 3.6.2 CAPS Dropsonde and Minirefractiionsonde

Both of these sondes use the Honeywell-developed CAPS type sensor for pressure measurement. An equation for calculating CAPS-measured pressure has been furnished by Mr. Curt Machenbacher of Honeywell. It employs 18



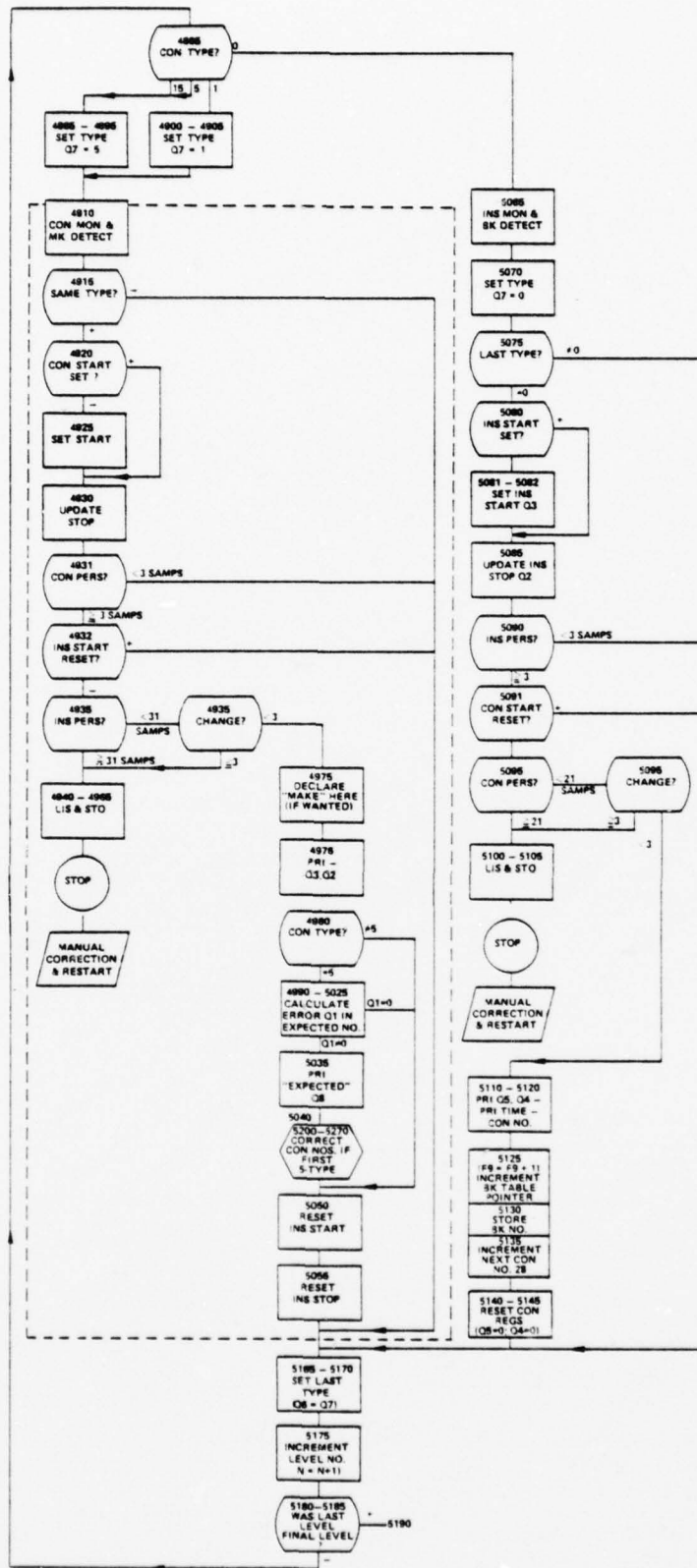

Figure 3-1. Flowchart of Break Detection Processing



coefficients that are customized on a sensor-by-sensor basis and is the basis for the following method, used for calculating pressure (mb) for CAPS-equipped sondes:

$$P = (L_{1,1} + L_{1,2} V_{cc} + L_{1,3} V_{cc}^2) (L_{1,4} + L_{1,5} T_p + L_{1,6} T_p^2) \\ + (L_{2,1} + L_{2,2} V_{cc} + L_{2,3} V_{cc}^2) (L_{2,4} + L_{2,5} T_p + L_{2,6} T_p^2) K V_{cc} R_p \\ + (L_{3,1} + L_{3,2} V_{cc} + L_{3,3} V_{cc}^2) (L_{3,4} + L_{3,5} T_p + L_{3,6} T_p^2) K^2 V_{cc}^2 R_p^2$$

where:

$P$  = pressure in millibars

$V_{cc}$  = supply voltage at input to pressure sensor measured at approximately 0°C and supplied with sonde

$T_p$  = temperature of pressure sensor in degrees Kelvin

$K$  = ratio of reference voltage to supply voltage, supplied with each sonde

$R_p$  = ratio of reference period to pressure period ( $R_p < 1$ )

$L_{1,1} \dots L_{3,6}$  = 18 sensor calibration coefficients supplied with each sonde.

### 3.7 CALCULATE $e_s$

Saturated water vapor pressure in millibars,  $e_s$ , is calculated for all three sondes according to:

$$e_s = \frac{1013.246 \times 10^{8.1328 \times 10^{-3}} [10^{-3.49149 (\frac{1-t}{t})} - 1]}{t^{5.02808} \times 10^{7.90298 (\frac{1-t}{t})} \times 10^{1.3816 \times 10^{-7}} [10^{11.344(1-t)} - 1]}$$

where

$$t = \frac{T + 273.16}{373.16}$$

$T$  = air temperature (°C)



3.8 CALCULATE REFRACTIVITY, N

N is calculated for all three sondes according to:

$$N = \frac{77.6P - .056 H_R e_s}{T_A + 273.16} + \frac{3750 H_R e_s}{(T_A + 273.16)^2}$$

$T_A$  = air temperature ( $^{\circ}\text{C}$ )

$H_R$  = relative humidity (%)

$e_s$  = saturated water vapor pressure (mb)

$P$  = total pressure (mb)

3.9 CALCULATE AND CLASSIFY REFRACTIVITY GRADIENT

The refractivity gradient,  $\frac{dN}{dA}$ , is calculated for all three sondes according to:

$$\frac{dN}{dA} = - \frac{N_i - N_{i-1}}{A_i - A_{i-1}}$$

where

$N_i$  = refractivity at current altitude,  $A_i$

$N_{i-1}$  = refractivity at previous altitude,  $A_{i-1}$

$A_i$  and  $A_{i-1}$  are altitudes in feet

$A_i > A_{i-1}$

The refractivity Gradient,  $\frac{dN}{dA}$ , is classified for all three sondes according to the following:



<u>Range</u>	<u>Classification</u>
$\frac{dN}{dA} < -0.048$	Trapping
$-0.048 \leq \frac{dN}{dA} < -0.024$	Superfractive
$-0.024 \leq \frac{dN}{dA} < 0$	Normal
$0 \leq \frac{dN}{dA}$	Subfractive

3.10 DETERMINE M-UNITS

M-units are determined for all three sondes as follows:

$$M = N + 0.048 A$$

where

A = altitude (feet)

3.11 DETERMINE DEW POINT DEPRESSION

First, partial pressure due to water vapor is calculated for all three sonde types per the expression:

$$e_w = \frac{H_R}{100} e_s$$

Next, temperature is found (by reiterative calculation) at which  $e_s$  will equal the above calculated value of  $e_w$ . This is the dew point temperature.



Finally, dew point temperature is subtracted from air temperature,  $T_A$ , to obtain dew point depression.

3.12 CALCULATE ABSOLUTE HUMIDITY,  $H_{ABS}$

The following formula is utilized for all three sondes:

$$H_{ABS} = D_o \frac{e_w}{P_o} \frac{T_o + 273.16}{T_A + 273.16} \text{ grams/m}^3$$

where

$D_o$  = vapor density in  $\text{g/m}^3$  at temperature  $T_o$  °C and pressure  $P_o$  millibars

$e_w$  = partial pressure due to water vapor (millibars)

$T_A$  = air temperature (°C)

3.13 CALCULATE THICKNESS OF ATMOSPHERIC LAYER

Layer thickness is obtained for all three sonde types by:

$$\text{Thickness (meters)} = -29.263242 \bar{T}' \left( \ln \frac{P_u}{1000} - \ln \frac{P_u}{1000} \right)$$

where

$$\bar{T}' = \frac{28.8 (273.16 + \bar{T}) \bar{P}}{18 \frac{\bar{H}_R}{100} e_s (\bar{T}) + 28.8 \left[ \bar{P} - \frac{\bar{H}_R}{100} e_s (\bar{T}) \right]}$$

$\bar{P}$  = the geometric mean of the two pressures

$\bar{T}$  = the average temperature

$\bar{H}_R$  = the average relative humidity

$e_s(\bar{T})$  = the saturated vapor pressure at the average temperature,  $\bar{T}$



Altitude to any pressure is obtained by summation of thickness from surface pressure to desired altitude's pressure.

3.14 REFERENCE, TEMPERATURE, AND PRESSURE DATA RESTORATION

There are limits to the amount of change that can be detected by a sensor as a function of time. However, due to noise that can enter the system during data transmission, any given data signal can become distorted, usually by some multiple of five percent. Therefore, tests are performed to discover deviant samples, and when found they are restored to a value equal to the average of their bounding samples, if their bounding samples have been found to be reasonable.

When dealing with temperature, pressure, and reference signals, a reasonable sample-to-sample change is much less than five percent. Thus, a simple algorithm is used that determines if a sample deviates from its predecessor by more than a specified tolerance, and if the test proves positive, that value is restored.

3.15 HUMIDITY DATA RESTORATION

In the case of humidity, considerably larger signal changes can occur very quickly. If the aforementioned method of data testing were used, tolerances would have to be large enough to allow large data spikes to pass unrestored. Thus, to eliminate data spikes in humidity measurements, the following scheme was devised:

given  $\left\{ \begin{array}{l} A = \text{sample preceding one being tested} \\ B = \text{sample being tested} \\ C = \text{sample succeeding one being tested} \end{array} \right.$

If  $A \geq C$ , then:

If  $\frac{B}{A} > \frac{C}{A} (1.02)$  or if  $\frac{B}{C} < \frac{A}{C} (\frac{1}{1.02})$  then restore



Altitude to any pressure is obtained by summation of thickness from surface pressure to desired altitude's pressure.

### 3.14 REFERENCE, TEMPERATURE, AND PRESSURE DATA RESTORATION

There are limits to the amount of change that can be detected by a sensor as a function of time. However, due to noise that can enter the system during data transmission, any given data signal can become distorted, usually by some multiple of five percent. Therefore, tests are performed to discover deviant samples, and when found they are restored to a value equal to the average of their bounding samples, if their bounding samples have been found to be reasonable.

When dealing with temperature, pressure, and reference signals, a reasonable sample-to-sample change is much less than five percent. Thus, a simple algorithm is used that determines if a sample deviates from its predecessor by more than a specified tolerance, and if the test proves positive, that value is restored.

### 3.15 HUMIDITY DATA RESTORATION

In the case of humidity, considerably larger signal changes can occur very quickly. If the aforementioned method of data testing were used, tolerances would have to be large enough to allow large data spikes to pass unrestored. Thus, to eliminate data spikes in humidity measurements, the following scheme was devised:

given  $\left\{ \begin{array}{l} A = \text{sample preceeding one being tested} \\ B = \text{sample being tested} \\ C = \text{sample succeeding one being tested} \end{array} \right.$

If  $A \geq C$ , then:

If  $\frac{B}{A} > \frac{C}{A} (1.02)$  or if  $\frac{B}{C} < \frac{A}{C} (\frac{1}{1.02})$  then restore



If  $A < C$ , then:

If  $\frac{A}{B} > \frac{A}{C} (1.02)$  or if  $\frac{C}{B} < \frac{C}{A} (\frac{1}{1.02})$  then restore

By this method, all large changes that occur for a span of only one data point are deemed noise spikes. These spikes are then restored to the average value of their bounding samples, if these bounding samples pass a reasonableness test.

### 3.16 DATA REDUCTION

Since more data are acquired than is practical to process, an algorithm is employed to reduce the amount of data without losing significant information. This algorithm selects a data point for storage only if its succeeding data point deviates by more than some specified tolerance from the linear trend established by previous data. See diagram below.

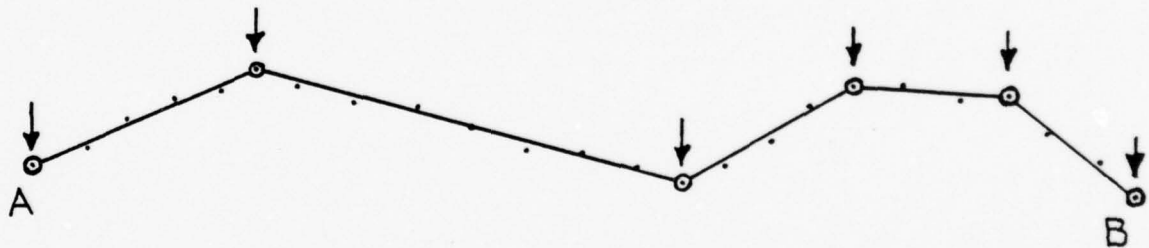

The points above represent a random sampling of data. The points indicated by the arrows are deemed significant being the last points that follow within a tolerance of a linear trend. Note that the first and last points, A and B, are automatically declared significant. See Figure 3-2 for the data reduction algorithm. Also incorporated into the algorithm is a feature that causes an entire cycle, meaning a temperature, a pressure,



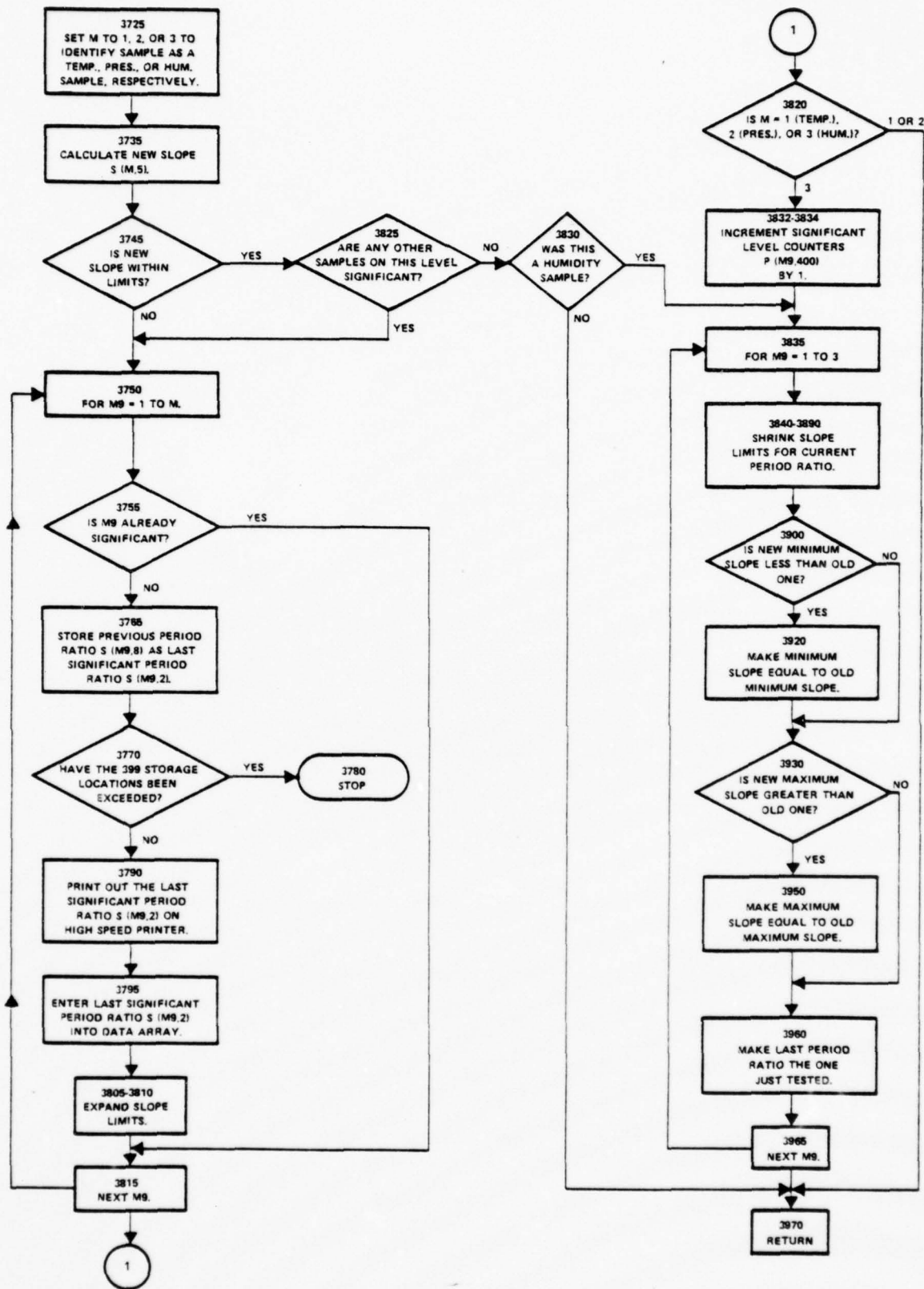

Figure 3-2. Subroutine: Declaration of Significant Period Ratios for CAPS-Equipped Sondes



and a humidity sample which occurred in succession, to be declared significant when any parameter in that cycle is found significant by testing its slope. This way, the number of temperature, pressure, and humidity samples is the same, and if one parameter is known at a particular time, the other two are known at nearly the same time.

### 3.17 GAP PROCESSING

Due to noise and/or other forms of interference, periods of erroneous data may be acquired. To these erroneous samples are applied various invalid data tags to make their future identification easy. Because of this and other interference effects, the reduced data array can contain tagged samples and other unreasonable quantities that passed through data restoration and reduction. To prevent undesirable values from proceeding further in the processing, a more complete data restoration, "Gap Processing," is performed. The regions of invalid data, called "gaps," are defined by the following two tests.

$$\text{If } M < \left( \frac{P_{N+1}}{P_N} \right)^{\frac{4}{T_{N+1} - T_N + R}} > \frac{1}{M} \text{ then } P_{N+1} \text{ is a gap}$$

where

$P_{N+1}$  is sample being tested

$P_N$  is the last sample found not to be a gap

$T_{N+1}$  is time-tag of sample being tested

$T_N$  is time-tag of the last sample found not to be a gap

$R$  is the number of time-tags of trend equivalent to noise

$M$  is allowed trend of ratio per frame (a frame being one complete cycle of reference, temperature, pressure, and humidity signals)

This algorithm proclaims the existence of a gap when the ratio between two data points does not lie within a range determined by the maximum



allowable change due to trend over the specified time period plus a constant term representing the probable maximum change due to noise.

The second test discovers samples which had been tagged invalid. This is done by seeing if they are outside the allowed range of data. If so, they are declared to be gaps.

When a gap has been found, the program will continue searching until it finds the next valid sample. Then, if the gap spans a time period less than two seconds, it will automatically be replaced with values that are geometrically interpolated between the samples bounding the gap. If, however, the gap spans a time greater than two seconds, the program stops. At this point, the operator can either run the program after the stop to execute the aforementioned geometric interpolation, or to fill the gap manually if other information is known.

Figure 3-3 shows an example of information displayed by the gap processing monitor. After a sufficient sampling of soundings has been processed to demonstrate that gap processing is "tuned" properly, the display may be eliminated.

### 3.18 DETERMINATION OF SURFACE PARAMETERS

#### 3.18.1 Baroswitch and CAPS Dropsondes

The program chooses the data array's last time-tag plus two as the time-tag for surface pressure. Then the value of surface pressure is determined by extrapolating to that surface time-tag using the linear slope determined from recent pressure samples. Here the operator may intervene and put in a different surface pressure value if desired. If this option is chosen, the program calculates the time-tag for the operator-entered surface pressure, again, by linear extrapolation. This can be done because of the nearly linear behavior of pressure with time. However, this argument is not



```

PC(1.99) CHANGED FROM 2725.00051836 TO 2725.64470835
PC(1.100) CHANGED FROM 2729.82236462 TO 2729.64472276
POST-GAP RATIO = 2733.64370697
                ES=0.240320002434
                ES=1.03254908713
DATA GAP <2 SEC BEING RESTORED
PRE-GAP VALUE =2766.64626932
PC(1.103) CHANGED FROM 2770.00051804 TO 2770.64633177
PC(1.104) CHANGED FROM 2774.78320921 TO 2774.64639423
POST-GAP RATIO = 2778.64736304
                END M=1
                START M=2
                ES=1.09241925163
                ES=1.03992542545
                ES=0.565466509971
                ES=0.000956314942
4300 IF INT(CE4)-INT(P(M,ES))<21 THEN 4320
DATA GAP EXCEEDS 2 SEC. SHOULD IT BE RESTORED?
STOP IN LINE 4313 PRIOR TO LINE 4320
DATA GAP <2 SEC BEING RESTORED
PRE-GAP VALUE =234.636894303
PC(N.4) CHANGED FROM 238.99990210 TO 238.636875974
PC(N.5) CHANGED FROM 234.9999 TO 234.637915913
PC(N.6) CHANGED FROM 233.999911832 TO 233.637036432
PC(N.7) CHANGED FROM 272.000011831 TO 272.637058407
POST-GAP RATIO = 276.637033082
                ES=0.240676841025
                ES=0.247764203093
                ES=0.410197113115
                ES=0.452096526583
                ES=0.993033032143
4300 IF INT(CE4)-INT(P(M,ES))<21 THEN 4320

```

Figure 3-3. Monitor Display Illustrating Operation of Gap Processor



valid for temperature and pressure. For these two parameters, the program either repeats the last samples in the data array or inputs operator selected values. To keep the surface level in the same format as the previous data, the time-tags for surface temperature and humidity are chosen to be the surface pressure's time-tag minus one and plus one respectively.

### 3.18.2 Minirefractiionsonde

The surface conditions should already be resident in the data array because the balloonsonde should start transmitting several seconds before launch. The program first prints out the pressure values from the bottom up until it passes through a range of ten millibars, since the desired quantity lies near the end of the data. Now the program scans the data from the bottom up and the last value encountered before an increasing trend occurs is chosen as the surface pressure. The operator is still given a choice, however, to make the surface pressure any of the displayed values. Surface temperature and humidity automatically become the samples in the same level of the data array as the surface pressure.

### 3.19 THREE-CYCLE STACK OPERATIONS

Most of the analyzer's processing of raw data is accomplished while the data are moving through a three-cycle stack. The stack holds three complete commutation cycles and the four reference values that bound them.

A cycle is declared in sync if it consists of three consecutive values in the data range and is bounded by two values in the reference range. The cycle is validated and found qualified for analysis if its individual values pass reasonableness checks in which they are compared with their corresponding values in the predecessor and/or successor cycles. The data restoration functions are also performed in the stack. The last stage of processing in stack results in the calculation of time-tagged period ratios that eliminate the need for carrying reference values any further. Only the significant period ratios are stored in the reduced data file.



The elimination of reference values and insignificant data values causes the data bank to be small enough for residence in internal memory, greatly reducing the processing time.

The operations of the three-cycle stack are detailed in the flowchart shown in Figure 3-4.

### 3.20 OTHER SOFTWARE DESIGN FEATURES

In addition to the 19 design features already described, graphic display monitors and reports are included in the analyzer software as illustrated in this report. Further design features include a software system architecture applicable for microprocessor use in the fleet and a front end that can be used for storing digitized data either on magnetic tape or on a RAM board.



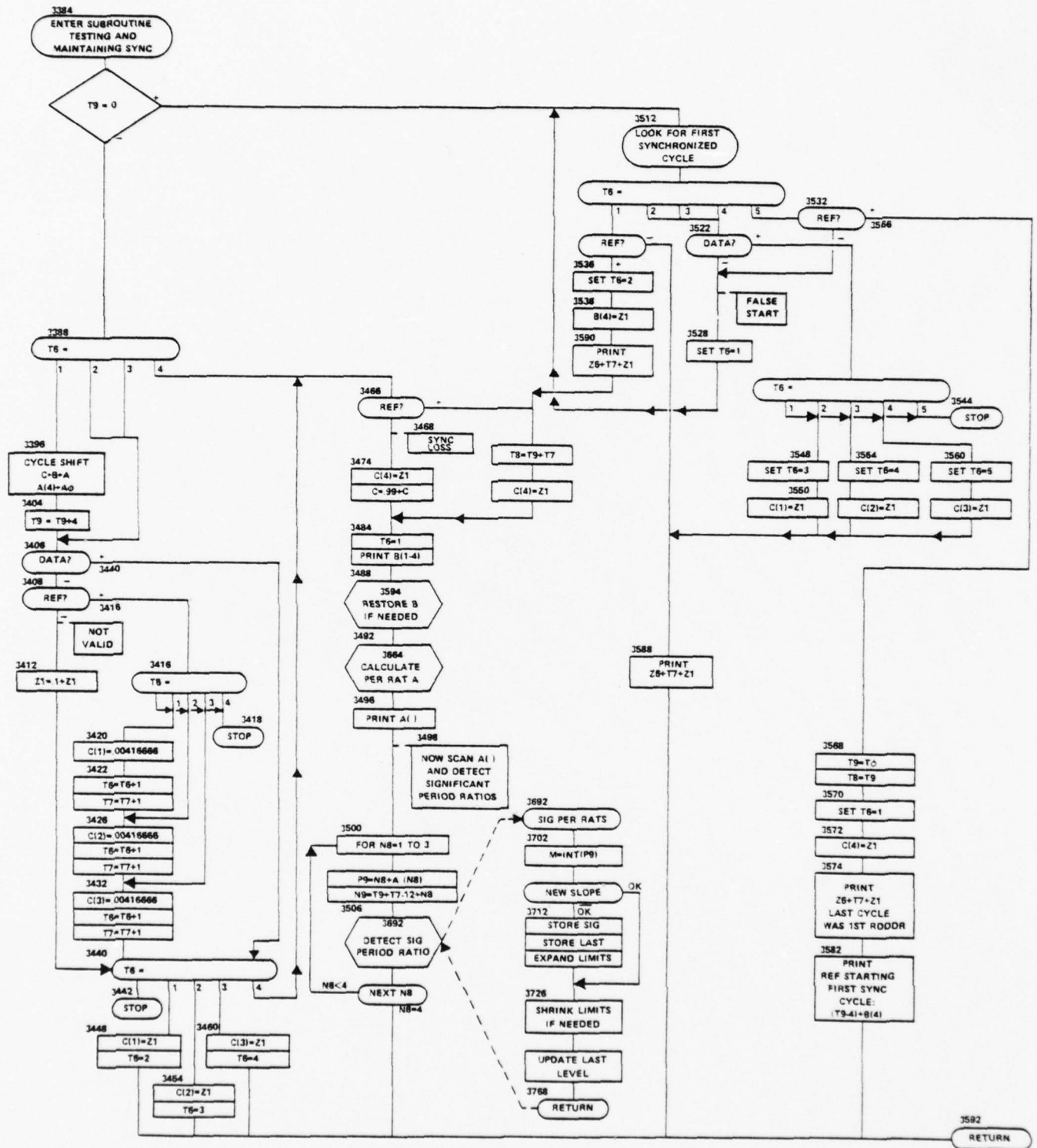

Figure 3-4. Operation of 3-Cycle Stack



## 4. OPERATING INSTRUCTIONS

It is assumed that the operator has some familiarity with the Tektronix 4051 Graphic Computing System such as can be gained in several hours of reading the Tektronix manuals and experimenting with the system. It is also assumed, of course, that the operator is of a technician or engineer skill level and is familiar with computer terminology.

### 4.1 PRECAUTIONS

The tape cassette read head must be cleaned periodically. Follow Tektronix instructions. Note that the program cassette appropriate to the baroswitch dropsonde (cassette V or VIII), the CAPS dropsonde (cassette IX), or the minirefractionsonde (cassette X) must be inserted. All three programs are on "backup" cassette XIII.

----- C A U T I O N -----

The cassettes have a "safe" lock to prevent accidental writing on the tape. When writing is wanted, make sure the cassette is set off "safe" before attempting the write operation. If this is not done, an error message will be produced when file marking (or writing) is attempted. If such an error occurs, make certain the FIND statement is repeated. Failure to do so may cause loss of other files from tape.

Before a cassette is used in the program ensure that it has at least the first file already marked or the possibility exists of the tape running off of one of its reels. Also note that when a mark statement is executed, all files on tape succeeding that marked file are destroyed.



Time does not permit the investigation of all possible combinations of operating conditions in a complex computer system. Therefore, seemingly trivial departures from these operating instructions might cause improper operation. Follow the instructions carefully.

#### 4.2 BAROSWITCH DROPSONDE PROCESSING

Operating instructions are included in the program and cover operations peculiar to dropsonde processing. These instructions are included in the software in interactive fashion and are very explicit. Other instructions that could not be conveniently included in the program are included in this section.

##### 4.2.1 Calibration and Acquisition

All controls, buttons, keys, etc. are found on the 4051, unless otherwise noted.

- (1) Turn on the 4051, hard copy unit, HP counter, EECO reader.
- (2) Press PAGE button on 4051 keyboard when screen floods.
- (3) Insert the Breadboard Dropsonde Analyzer program cassette V into internal unit of the 4051 and press AUTOLOAD.
- (4) Follow instructions given on the screen of the 4051.
- (5) When the screen indicates that the tape reader should be prepared for operation, make certain the tape reader is connected to the GPIB and the calibration tape is loaded in the reader with the start block's center at the photo electric reader. The start block is a series of about 30 or 40 rubouts (all holes punched).
- (6) When the screen indicates that the HP counter should be prepared for operation, make certain the following conditions exist (these conditions should be achieved with GPIB disconnected to make certain there is no accidental data entry or interrupt of the 4051):



- (a) Magnetic tape reproducer unit turned on with tape loaded and ready to start reading tape several seconds before signal start.
- (b) Magnetic tape reproducer unit's output signal connected through filter to HP counter input A and from HP counter output A to decommutator unit.
- (c) Decommulator Unit turned on and preadjusted for synchronous decommutation in accordance with its operating instructions.
- (d) Decommulator's read enable output connected to channel B of HP counter.
- (e) HP counter controls set as follows:
  - GPIB address = 3 (on rear of counter)
  - function PER AVG = A
  - N = 10
  - sample rate = HOLD
  - Level A settings
    - trigger = 12:30 o'clock (approx. zero volt level)
    - delay = OFF
    - slope = +
    - atten = 1
  - Level B settings
    - trigger = 3:00 o'clock (approx. 1.2 volt level)
    - slope = +
    - atten = 1
    - coupling = DC
  - Channel connections = SEP, 1 M $\Omega$
- (f) Above conditions should be achieved and a dry run started with GPIB disconnected to measure time duration of data and to ascertain that reasonable counts are being obtained on HP counter (and that satisfactory decommutation trace is observed on oscilloscope, if helpful).
- (g) Re-establish start conditions after OK operation is confirmed.



Connect the GPIB cable. The counter is now ready to enter data into the 4051, and the return key on the 4051 should be depressed only after all the above preparations have been made and the time duration has been entered into the 4051.

After the return key has been depressed, the 4051 is waiting for interrupts from the HP counter. The tape reproduction unit should then be turned on, and the data entry will commence.

When all the data have been entered, stop the reproducer.

- (7) Following data entry, the screen will display the data obtained so that it may be checked for reasonableness. The operator will then be given an option to re-enter the data, if desired. If the operator elects to continue, a copy of the data may be made and the data will be recorded on a magnetic cassette. The magnetic tape cassette number and file numbers should be recorded for future use.
- (8) The data file and calibration files have been built when so advised by the screen.

#### 4.2.2 Analysis

Further processing is accomplished by simply reinserting program cassette V in the internal unit and pressing AUTOLOAD. When the screen asks for a selection of option, select analysis instead of calibration and acquisition.

As before, the screen will give explicit instructions whenever something is to be done by the operator. Most of these instructions are concerned with options the operator may select. The analysis will continue through files 2 and 3 and conclude with production of reports by file 4.



### 4.3 CAPS DROPSONDE AND MINIREFRACTIONSSONDE PROCESSING

Operating instructions are included in the program and cover operations peculiar to CAPS-equipped sondes. These instructions are included in the software in interactive fashion and are very explicit as they appear on the screen. Other instructions that could not be conveniently included in the program are included in this section.

#### 4.3.1 Calibration and Acquisition

All controls, buttons, keys, etc. are found on the 4051, unless otherwise noted.

- (1) Turn on the 4051, hard copy unit, HP counter, EECO reader.
- (2) Press PAGE button on 4051 keyboard when screen floods.
- (3) Insert the Breadboard Dropsonde Analyzer program cassette\* into the internal unit of the 4051 and press AUTOLOAD.
- (4) Follow instructions given on the screen of the 4051.
- (5) When the screen indicates that the HP counter should be prepared for operation, make certain the following conditions exist (these conditions should be achieved with GPIB disconnected to make certain there is no accidental data entry or interrupt of the 4051):
  - (a) Magnetic tape reproducer unit turned on with tape loaded and ready to start reading tape several seconds before signal start.
  - (b) Magnetic tape reproducer unit's output signal connected through filter to HP counter input A and from HP counter output A to Decommulator Unit.

\*Insert cassette IX if CAPS Dropsonde, X if Minirefractionsonde.



(c) Decommutator Unit turned on and preadjusted for synchronous decommutation in accordance with its operating instructions.

(d) Decommutator's rear enable output connected to arming signal input on rear of HP counter.

(e) HP counter controls set as follows:

GPIB address = 3 (on rear of counter)

function PER AVG = A

N = 10

sample rate = HOLD

Level A settings

trigger = 12:30 o'clock (approx. zero volt level)

delay = OFF

slope = +

atten = 1

Level B settings

trigger = 3:00 o'clock (approx. 1.2 volt level)

slope = +

atten = 1

coupling = DC

Channel connections = SEP, 1 M $\Omega$

(f) Above conditions should be achieved and a dry run started with GPIB disconnected to measure time duration of data and to ascertain that reasonable counts are being obtained on HP counter (and that satisfactory decommutation trace is observed on oscilloscope, if helpful).

(g) Re-establish start conditions after OK operation confirmed.

Connect the GPIB cable. The counter is now ready to enter data into the 4051, and the return key on the 4051 should be depressed only after all the above preparations have been made and the data time duration has been input to the 4051.

After the return key has been depressed, the 4051 is waiting for interrupts from the HP counter. The tape



reproduction unit should then be turned on, and the data entry will commence.

When all the data have been entered, stop the reproducer.

- (6) Following data entry, the screen will display the data obtained so that it may be checked for reasonableness. The operator will then be given an option to re-enter the data, if desired. If the operator elects to continue a copy of the data may be made and the data will be recorded on a magnetic cassette. The magnetic tape cassette number and file numbers should be recorded for future use.
- (7) The data file and calibration files have been built when so advised by the screen.

#### 4.3.2 Analysis

Further processing is accomplished by simply reinserting the program cassette\* into the internal unit and pressing AUTOLOAD. When the screen asks for a selection of option, select analysis instead of calibration and acquisition.

As before, the screen will give explicit instructions whenever something is to be done by the operator. Most of these instructions are concerned with options the operator may select. Analysis will proceed through files 2 and 3 and conclude with reports output by file 4. Note that in the case of program stops encountered during "gap processing," section 3.17 explains the options provided.

\*Cassette IX if CAPS Dropsonde, X if Minirefraktionssonde.



reproduction unit should then be turned on, and the data entry will commence.

When all the data have been entered, stop the reproducer.

- (7) Following data entry, the screen will display the data obtained so that it may be checked for reasonableness. The operator will then be given an option to re-enter the data, if desired. If the operator elects to continue a copy of the data may be made and the data will be recorded on a magnetic cassette. The magnetic tape cassette number and file numbers should be recorded for future use.
- (8) The data file and calibration files have been built when so advised by the screen.

#### 4.3.2 Analysis

Further processing is accomplished by simply reinserting the program cassette\* into the internal unit and pressing AUTOLOAD. When the screen asks for a selection of option, select analysis instead of calibration and acquisition.

As before, the screen will give explicit instructions whenever something is to be done by the operator. Most of these instructions are concerned with options the operator may select. Analysis will proceed through files 2 and 3 and conclude with reports output by file 4. Note that in the case of program stops encountered during "gap processing", section 3.17 explains the options provided.

\*Cassette IX if CAPS Dropsonde, X if Minirefraktionsonde.



## 5. PROGRAM DOCUMENTATION

### 5.1 PROGRAM LISTINGS AND ANNOTATION

The programs are written in Tektronix Extended Basic for the Tektronix 4051 Graphic System. The listings of the four files of each program are presented in Appendixes D, E and F as shown below.

#### DIRECTORY OF PROGRAM LISTINGS

<u>PROGRAM NAME</u>	<u>FILE NUMBER AND NAME</u>	<u>APPENDIX</u>	<u>FIGURE</u>
BAROSWITCH DROPSONDE	1. Calibration-Acquisition	D	D-1
BAROSWITCH DROPSONDE	2. Reduced Data File Builder	D	D-2
BAROSWITCH DROPSONDE	3. T, P, H Table Builder	D	D-3
BAROSWITCH DROPSONDE	4. Output Report Generator	D	D-4
CAPS DROPSONDE	1. Calibration-Acquisition	E	E-1
CAPS DROPSONDE	2. Reduced Data File Builder	E	E-2
CAPS DROPSONDE	3. T, P, H Table Builder	E	E-3
CAPS DROPSONDE	4. Output Report Generator	E	E-4
MINIREFRACTIONSONDE	1. Calibration-Acquisition	F	F-1
MINIREFRACTIONSONDE	2. Reduces Data File Builder	F	F-2
MINIREFRACTIONSONDE	3. T, P, H Table Builder	F	F-3
MINIREFRACTIONSONDE	4. Output Report Generator	F	F-4

Note that remark (REM) statements are used liberally throughout the program to explain what is being done and to define variables used in sub-routine interfaces and within the programs. Many of the subroutines are very simple and such remarks make them self-explanatory.

Where adequate, the remark statements are the preferred method of program documentation because they are easily updated and they "follow" the program whenever it is renumbered automatically.



See Sections 3.19, 3.16 and 3.20 of Technical Design Basis for flowcharts on three-cycle stack operations, significant period ratio determination, and baroswitch make/break detection.

## 5.2 ASSIGNMENT OF VARIABLES

The number of variables assigned in the three programs approaches the total number of variables allowed by the programming languages. As a guide, Table 5-1 gives the variables assigned in the CAPS dropsonde and minirefractionsonde programs. The variables with numbers of order 7, 8, or 9 (for example M9 or D7) are usually short-lived, and may have several different designations. Most variables of low number (for example F0 or L1) are long-lived and may have only one designation. Pure letter variables (such as B or D) are usually subscripted and represent arrays.



Table 5-1. List of Variables in Programs  
for CAPS Dropsonde and Mini Refraction Sonde

	b	0	1	2	3	4	5	6	7	8	9	\$
A	✓	✓	✓								✓	✓
B	✓	✓									✓	✓
C	✓				✓	✓	✓	✓	✓	✓	✓	
D	✓	✓	✓						✓	✓	✓	
E				✓	✓	✓	✓	✓	✓	✓	✓	
F	✓	✓	✓							✓	✓	
G		✓	✓	✓	✓	✓	✓	✓				
H		✓	✓	✓	✓	✓	✓	✓	✓	✓	✓	
I	✓								✓	✓	✓	
J	✓	✓										
K		✓									✓	
L	✓	✓	✓	✓					✓	✓	✓	
M	✓										✓	✓
N	✓	✓								✓	✓	✓
O	✓											✓
P	✓		✓	✓			✓	✓	✓	✓	✓	
Q	✓	✓	✓	✓	✓	✓	✓	✓	✓	✓	✓	
R	✓				✓	✓				✓	✓	
S	✓	✓								✓	✓	✓
T	✓	✓	✓	✓	✓	✓	✓	✓	✓	✓	✓	✓
U	✓						✓	✓	✓	✓	✓	✓
V		✓	✓			✓	✓	✓	✓	✓	✓	
W			✓	✓	✓	✓	✓	✓	✓	✓	✓	✓
X	✓											
Y	✓											
Z	✓	✓	✓					✓	✓	✓	✓	✓



## 6. OPERATIONAL RECORDER-ANALYZER INVESTIGATIONS

The investigations reported in this section were directed toward simplifying the data recording and analysis for operational adaptation.

### 6.1 BAROSWITCH CALIBRATION SIMPLIFICATION

#### 6.1.1 Introduction

##### 6.1.1.1 Purpose

The goal of this effort was to simplify the equipment and/or procedures for introducing baroswitch calibration data into dropsounding processors.

##### 6.1.1.2 Background

The baroswitch calibration data are obtained by automatically recording each contact-make pressure while the pressure is slowly decreased. Each switch is purchased with calibration data in two forms:

- (1) A printed table of pressure values in millibars, showing the pressure for each contact-make during pressure reduction; and
- (2) A punched paper tape containing the same pressure values

Both the table and tape contain the switch serial number and pressure data check sum to provide confidence in switch identification and data.



#### 6.1.1.3 Data Entry Problems

There are two data entry methods that can be implemented, based on the existing data forms:

- (1) By using the printed table, the pressures can be entered manually with a keyboard that already exists in the processing system.
- (2) By using the tape, the pressures can be entered with a punched tape reader that would be interfaced with the processor specifically for that purpose.

Both methods have disadvantages. The manual method is very slow, resulting in poor processing response and high operating cost. The second method requires the addition of a dedicated punched paper tape reader, causing higher procurement and logistics costs.

#### 6.1.1.4 Solution by Eliminating Data Redundancies

If the quantity of calibration data can be reduced so that entry can be accomplished with the existing keyboard about as quickly as by tape reader, there will be an advantage, assuming that the reduced quantity of data can be produced automatically at a cost that is less than the data introduction cost using either previous alternative.

The automatic baroswitch calibration redundancy eliminator described here has been tested and evaluated and found capable of greatly reducing the quantity of data entries, while maintaining a controlled accuracy. It operates on a digital basis so that reconstruction of the contact pressures can be accomplished with zero error. However, significant further reductions are frequently possible by permitting small tolerable errors.



## 6.1.2 Redundancy Elimination Program

### 6.1.2.1 Program Description

The redundancy eliminator has been implemented in the Bread-board Dropsonde Analyzer in the following way.

A punched tape input is used to build an internally stored file of pressures. These pressures for individual contacts are then used to calculate and file the pressure intervals between successive contacts. A profile of local interval averages is calculated and used as a basis for calculating each interval's deviation. The intervals are smoothed by adjusting intervals in the order of their deviation, largest first. The adjustments are made to obtain agreement with neighboring intervals. When all deviations are small, roughly 0.7 millibar or less, final smoothing is applied by scanning the intervals and adjusting to a "staircase" type of profile, with the staircase risers representing the quantized interval changes and the staircase trends representing the persistence of each interval. Processing to achieve staircase is directed toward a near-minimum number of interval adjustments.

The interval staircase is encoded into a data block containing the initial interval, followed by the persistence of each interval, and concluded by the check sum of all the data in the staircase block. The staircase data block typically contains 15 to 20 hexadecimal digits. The smoothed intervals can be reconstructed from this staircase block.

The adjusted interval numbers are encoded into an intervals array containing the initial contact's deviation from standard pressure, followed by the increments between successive adjusted interval numbers, and concluding with a check sum. There are typically 30 to 35 adjusted intervals. The array contains about 20 to 25 digits including initial pressure and check sum digits when encoded with error tolerance. It identifies the staircase intervals that must be adjusted to obtain the original interval's profile.



Finally, the actual adjustments are encoded into an adjustment array of about 20 to 25 digits. The three arrays of roughly 70 digits contain all the data needed to reconstruct the pressure table.

A simplified flow chart depicting program operation is shown in Figure 6-1. A listing of the program is given in Appendix G.

#### 6.1.2.2 Program Operation

The program has been used to obtain smoothed interval profiles from five punched tapes selected at random from the representative tapes supplied by the government. The program uses the graphic display as a monitor providing a soft copy record of operations performed. A hard copy of the monitor display can be obtained by simply pressing the "copy" button before pressing "page". The monitor's displays include the pressure table.

The program output is printed on the line printer in such a way that accuracy and length of encoded message can be assessed easily. The printed outputs include the original intervals array, the interval adjustments and sequence during preliminary smoothing, the array of smoothed intervals, and the array of interval adjustments.

The hard copy of monitor displays and the line printer copy for baroswitch serial number 104-9661 are shown in Appendix H as an example of the complete program output obtained in a typical run.

The program operating instructions are simple: "FIND", "OLD" and "RUN" the program file. Respond to operator instructions as they appear on the monitor display. The program is stored in cassette IV, file 32 and in cassette I, file 25.



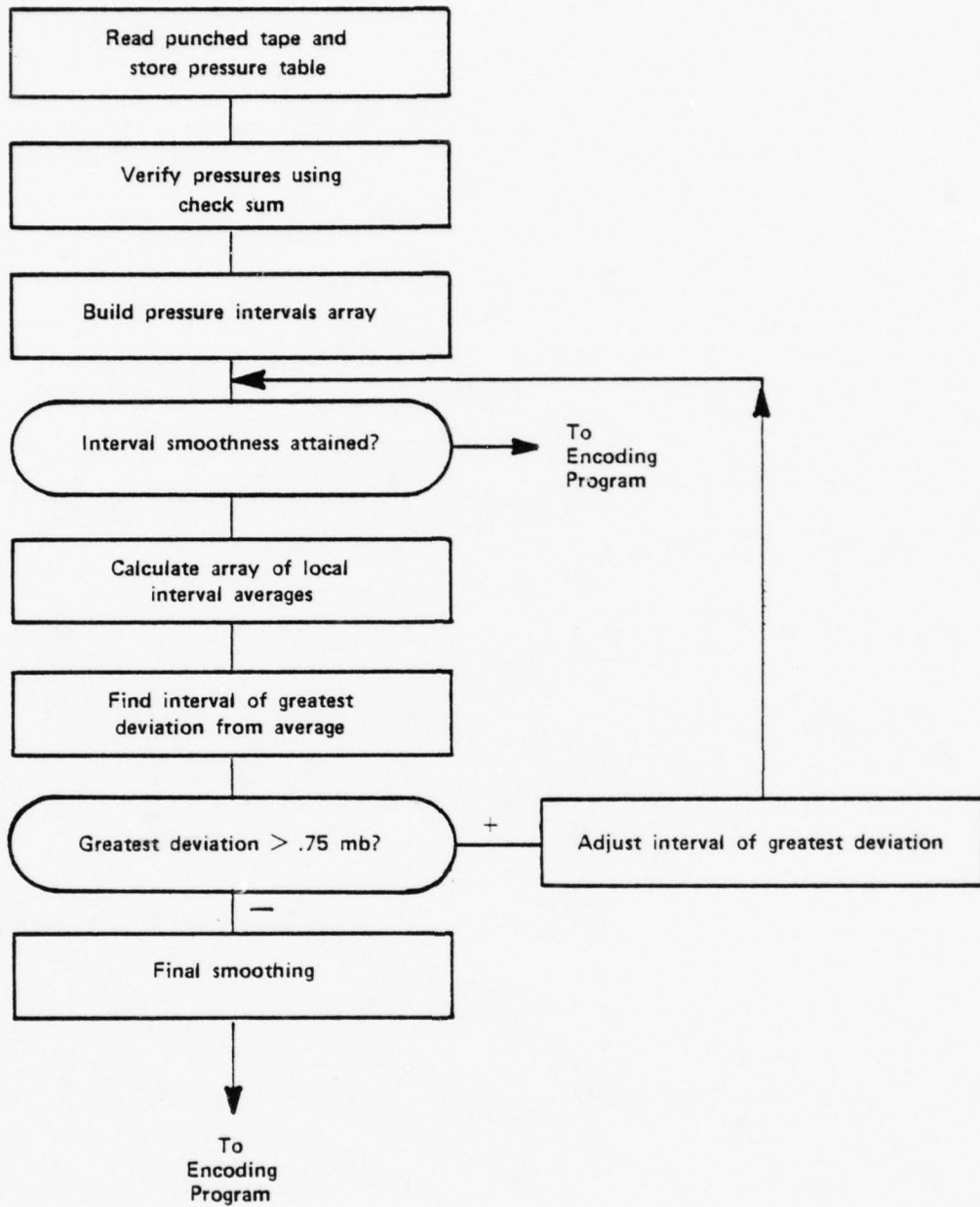

Figure 6-1. Simplified Flow Chart for Redundancy Eliminator



### 6.1.3 Program Test and Evaluation

#### 6.1.3.1 Test Results

The results of test runs on the five representative baroswitches, mentioned earlier, are shown in Appendix I. The results shown there are confined to the outputs essential for evaluation of the results and consist of pressure tables, original interval tables, adjustment tables, and smoothed interval tables. These tables are shown for each of the five baroswitches on a switch-by-switch basis for maximum clarity.

#### 6.1.3.2 Evaluation of Test Results

A detailed examination of the test results of Appendix I shows that the program achieves the desired smoothing of intervals as described in Section 6.1.2.1, and that the intervals, adjustments, and initial pressure are encodable as described for reconstruction of the original pressure table with absolute precision or with an error tolerance to obtain further reduction of data.

### 6.1.4 Conclusions

Development of the calibration redundancy eliminator has been advanced to the point where feasibility of the described approach has been demonstrated.

However, recent developments in the manufacture of baroswitches make it unadvisable to proceed into a more detailed implementation at this time. The manufacturer has recently introduced a "linear" contact board and improved the calibration resolution from 0.5 to 0.2 millibars and is planning further refinements in the near future. In addition, a "continuous" pressure sensor with advantages of weight and interpretation has recently been developed and might replace the baroswitch. Thus, baroswitch implementation in the dropsonde is uncertain and if it is in fact used, its performance should be assessed before finalizing the resolution and accuracy of the calibration redundancy eliminator.



## 6.2 SIGNAL CONDITIONER-DECOMMUTATOR PERFORMANCE

The signal conditioner-decommutator in the Bendix Recorder-Analyzer was designed to operate with asymmetrical signals of constant pulse width and variable pulse repetition rate. A design change to symmetrical signal (pulses of 50% duty factor) with variable pulse repetition rate was being considered. The signal conditioner-decommutator was operated with a symmetrical signal to obtain data illustrating its operation and which could be used as a guide by the manufacturer in making a design change. That investigation and its results are described here.

### 6.2.1 Introduction and Purpose

The Bendix signal conditioner and decommutator are designed to operate with pulsed signals of variable duty factor. The objective of this test was to assess its operation with symmetrical signals (50% duty factor). The testing took three runs showing significant differences between "Bendix-produced" data and "reference" data produced by a special test setup. Table 6-1 summarizes the salient setup features for the three runs.

### 6.2.2 Equipment Setup

Figure 6-2 shows the setup for the first data run. This run was taken on 13 January 1978 at 3:40 P.M.

Figure 6-3 shows the setup for the second data run. This run was taken on 16 January 1978 at 10:15 A.M.

Figure 6-4 shows the setup for the third data run. This run was taken on 16 January 1978 at 2:30 P.M.

### 6.2.3 Data Interpretation

The data resulting from the three runs can be found in Appendixes J, K, and L. These data can be interpreted in the following way. There are



Table 6-1. Summary of Run Conditions<sup>1</sup>

	FIRST RUN	SECOND RUN	THIRD RUN
Time, Date	3:40 P.M., 1/13/78	10:15 A.M., 1/16/8	2:30 P.M., 1/16/78
Signal to HP5328A From	Honeywell Repro	Bendix Conditioner (from point "F")	SKL Low Pass (2KHz cutoff)
Signal Arming HP5328A From	Bendix 60m-sec (from point "E")	Bendix 60m-sec (from point "E")	Special Purpose NADC Assembly pro- cessing HP Marker Output
Observed Trigger Level for Bendix Conditioner	~1.6 Volts <sup>2</sup>	~1.6 Volts <sup>2</sup>	Not Applicable
HP Trigger Level	0 Volts (+ slope)	+1 Volt (+ slope)	0 Volts (+ slope)

- Notes: 1. For more complete information of the three setups, see the diagrams in Section 2.
2. Approximately 1.6 volts observed with Tektronix 7633 set to 2 volts per division; later, 1.2 volts was observed with 1 volt per division.



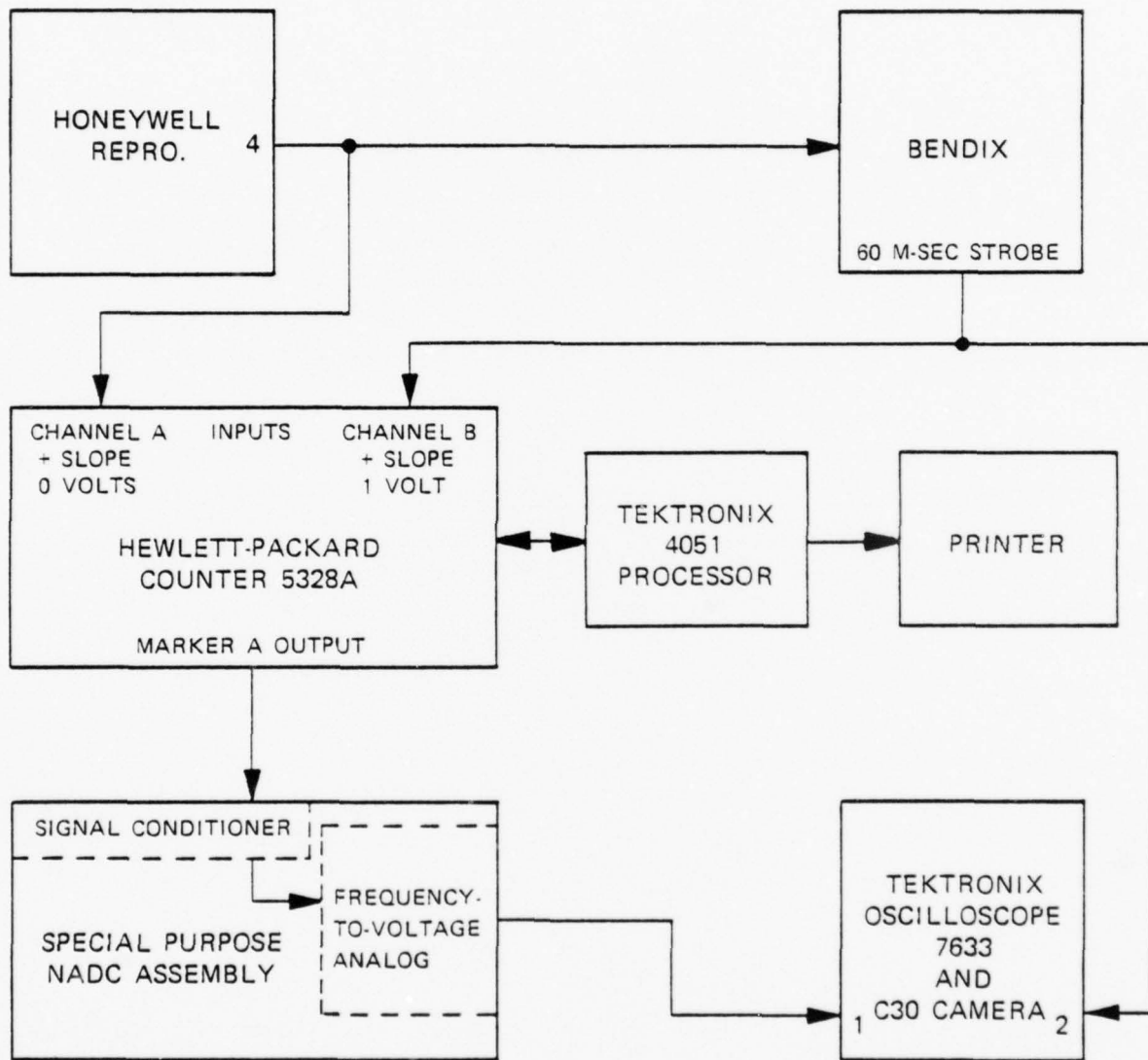

Figure 6-2 Setup of run at 3:40 PM, 13 January 1978.

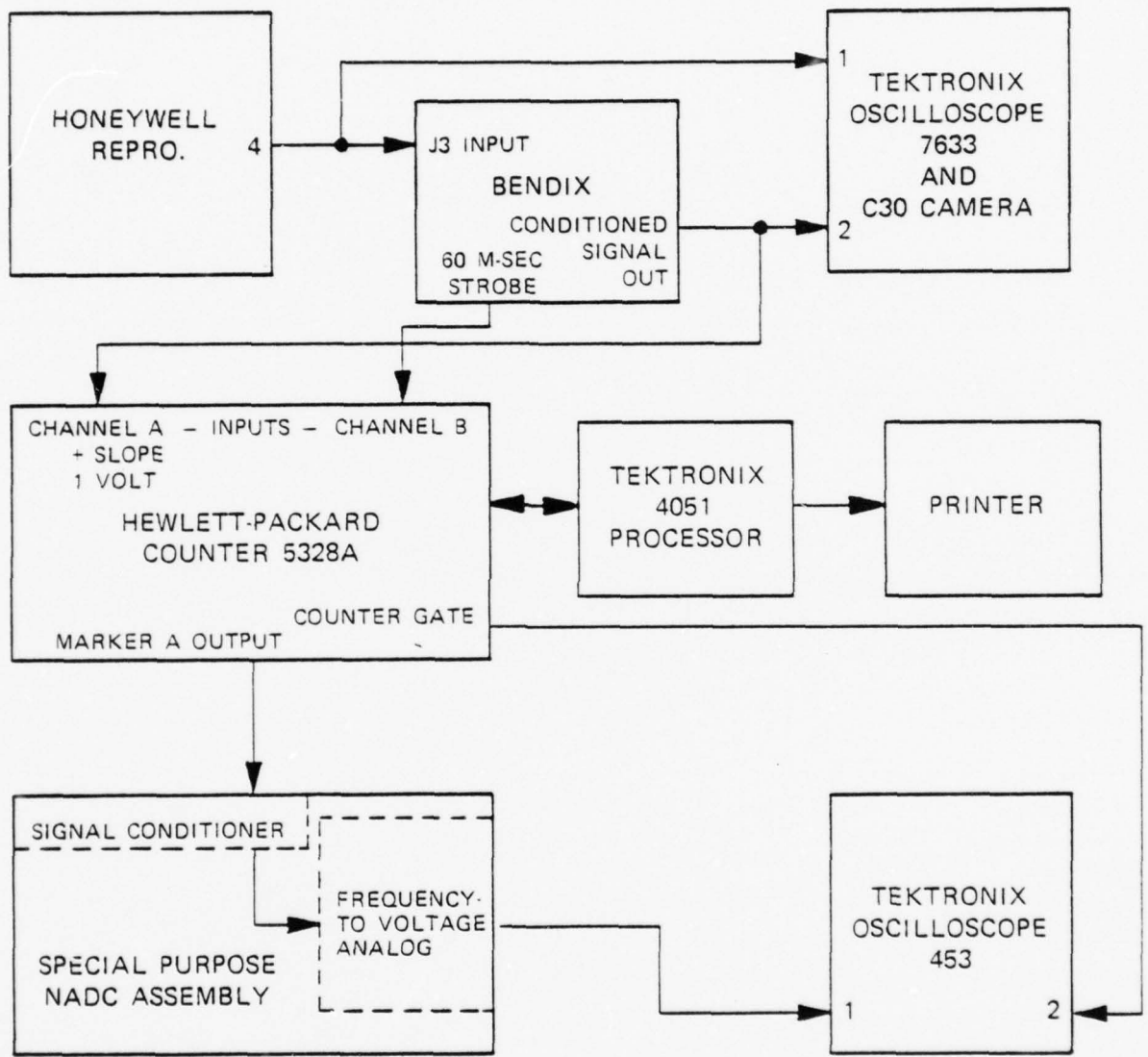

Figure 6-3 Setup of run at 10:15 AM, 16 January 1978.

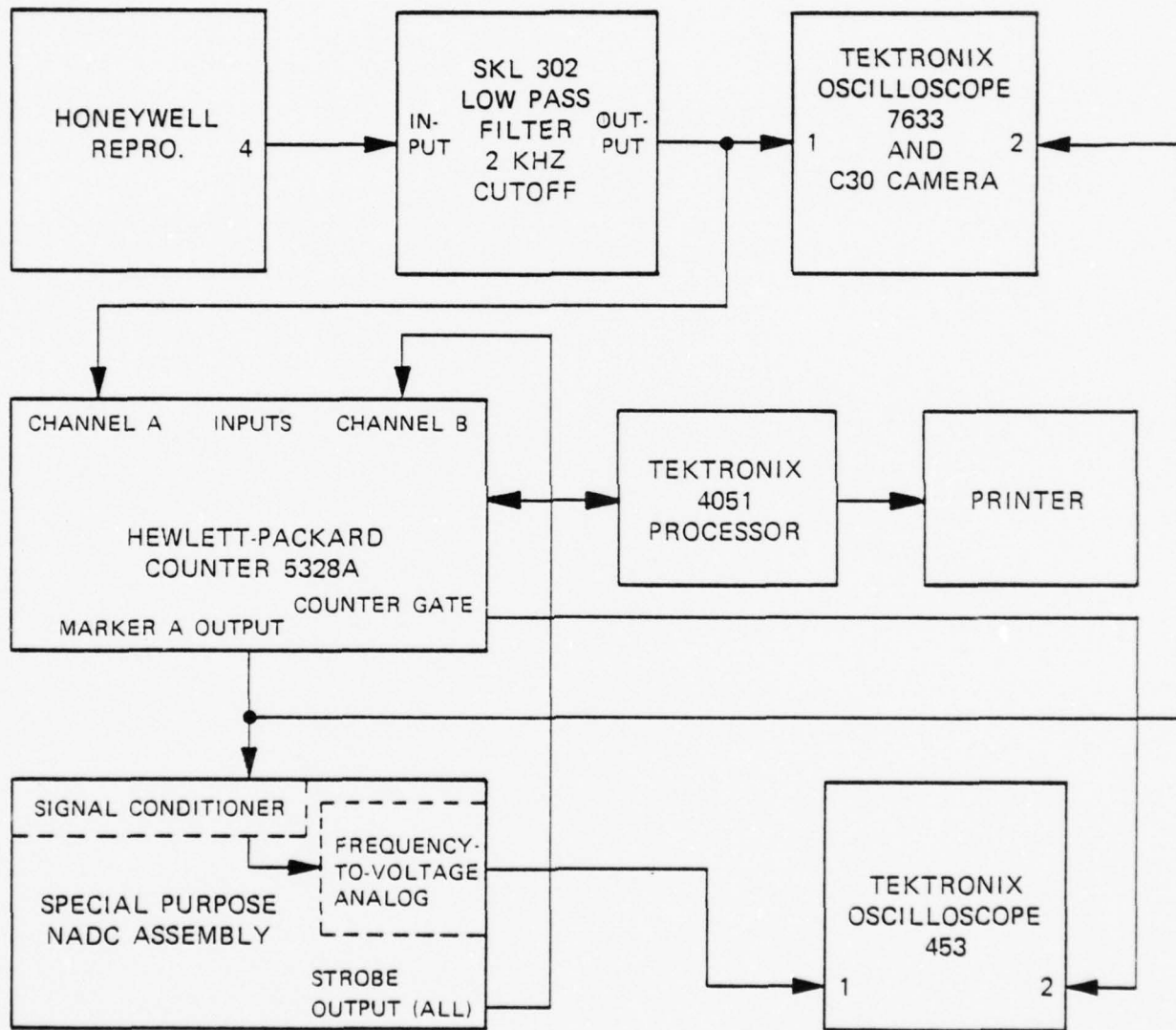

Figure 6-4 Setup of run started at 2:30 PM, 16 January 1978.

four words per line, each word containing two period samples separated by a decimal point. The sample to the left of the decimal point (integer portion of word) is in units of  $10^{-8}$  seconds. To obtain units of seconds, divide by  $10^8$ . The sample to the right of the decimal point (decimal portion) is in units of  $10^{-2}$  seconds. To obtain units of seconds, divide by  $10^2$ . For example, in column one of row one in the data from Appendix J, the word is "51506.079014," where 51506. is .00051506 seconds and .079014 is .00079014 seconds. Note that a period of .00051506 seconds corresponds to a frequency of 1942 Hertz which is in the reference frequency range.

The data (Appendix L) resulting from the third run were confirmed by oscillographic examination to be a good representation of the signal from the balloonsonde and is considered a satisfactory reference for evaluating the Bendix-produced data. The discrepancies between the data from the third run (Appendix L) and the data from the first (Appendix J) and second (Appendix K) runs are possibly explained in part by the photographs in Section 6.2.4, which show some of the cycle marking conditions observed during the runs.

#### 6.2.4 Monitoring and Photographing of Signal Conditions

During the three data runs and in trial runs made before any data were recorded, signals were carefully monitored via a Tektronics oscilloscope model 7633 equipped with a Tektronics camera model C30. This section contains photographs taken of some of the peculiarities which were found during the first and second runs.

There should have been a  $100\mu$ -sec pulse triggered by a positive slope at 1 volt. The triggered pulse was observed at 1.6 volts in the first run and at 1.2 volts in the second run. Other types of observed peculiarities were pulses that lasted longer than  $100\mu$ -sec and which triggered below the normal level. Other cases consisted of combinations of both of these.

During the third run, in which the Bendix unit was omitted, no discrepancies were observed in the production of conditioned signals.



780113 0900 MCW

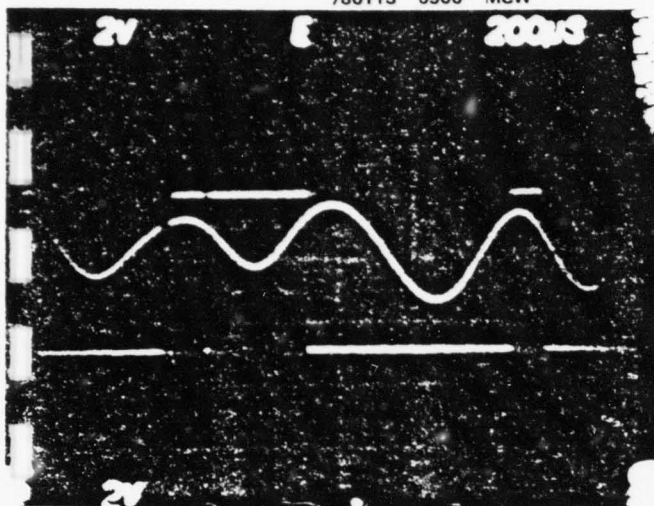

No. 1 Wallops No. 3 1933

780113 0904 MCW

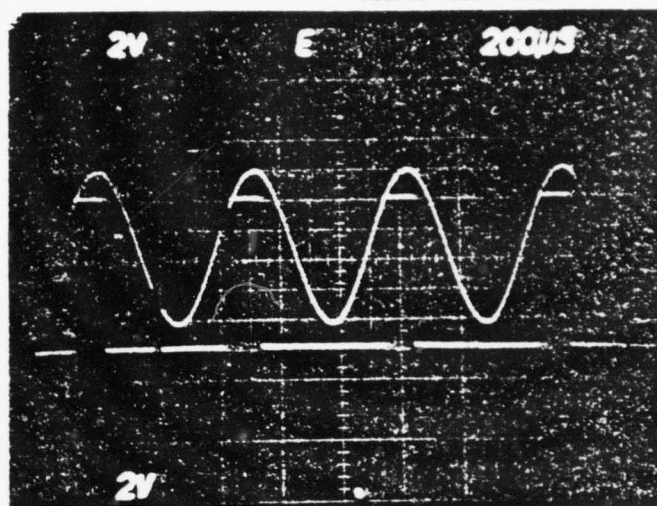

No. 2 Wallops No. 3 1937

780113 0907 MCW

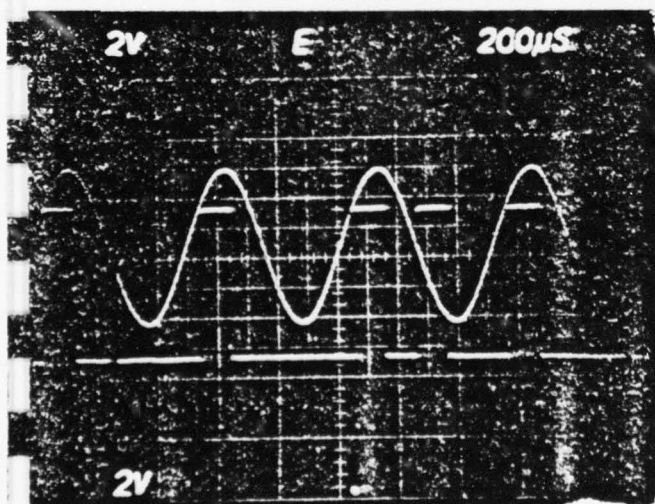

No. 3 Wallops No. 3 1940

780113 0918 MCW/PK

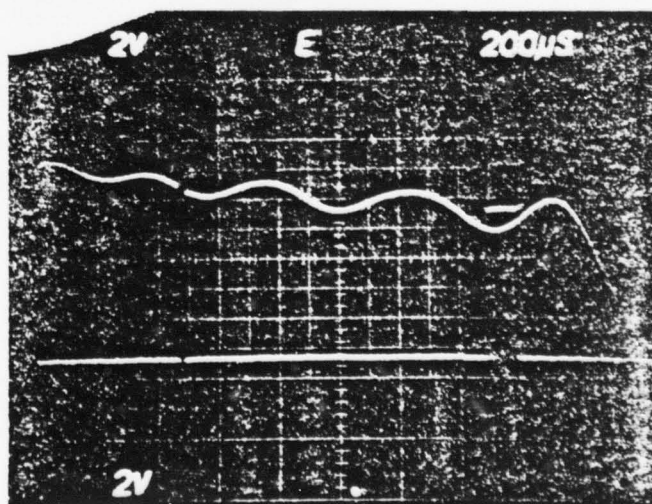

No. 4 Wallops No. 3 1951

Photographs taken during trial run on 13 January 1978

780113 0924 MCW/PK

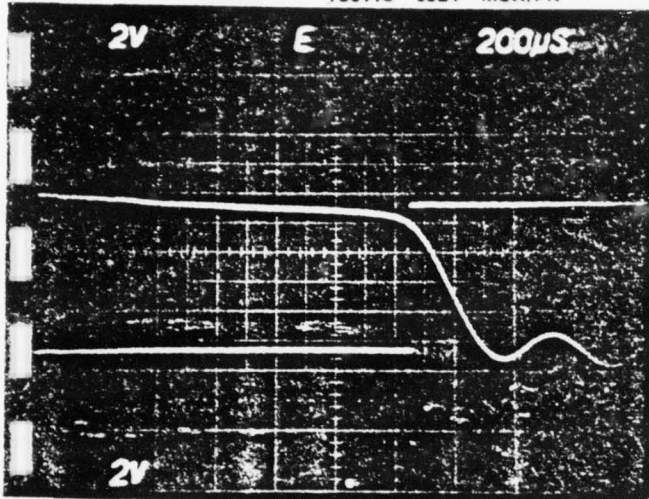

No. 5 WALLOPS No. 5 1957

780113 0928 MCW/PK

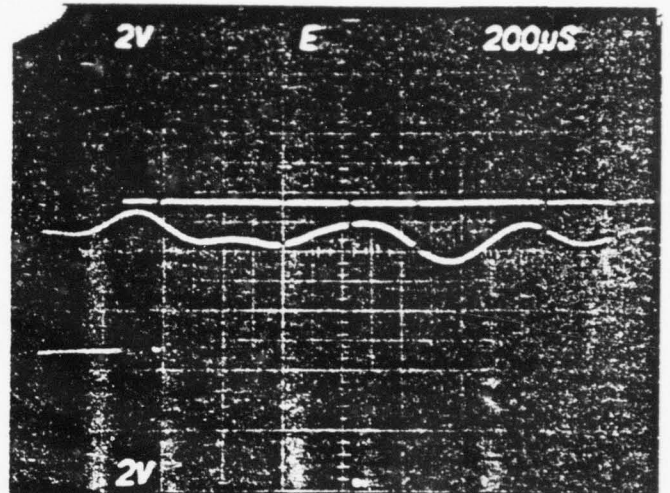

No. 6 WALLOPS No. 3 1906

780113 0939 MCW/PK

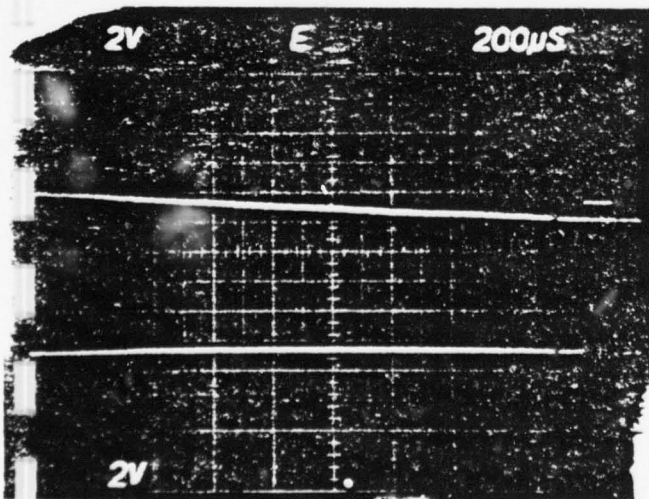

No. 7 WALLOPS No. 3 1917

780113 1015 MCW/PK

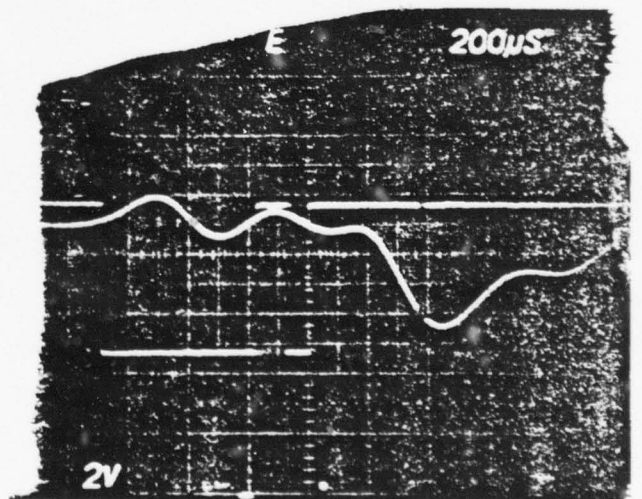

No. 8 WALLOPS No. 3 1953

Photographs taken during trial run on 13 January 1978

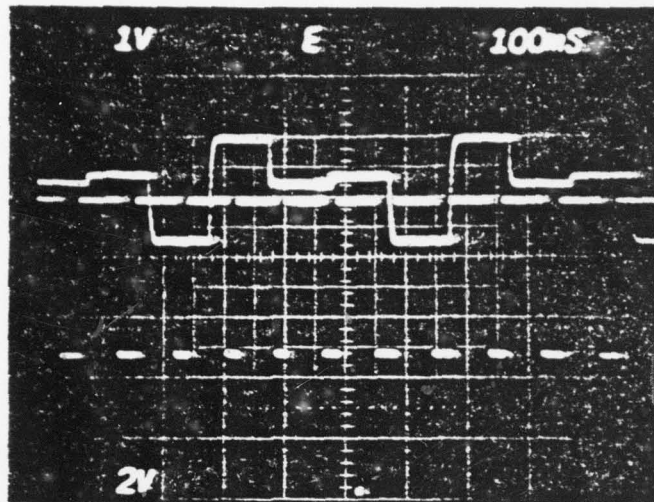

"PRE-TWEEK"

The above photograph was taken before the oscillator was "tweaked" to free-run at the sonde sample rate. The photographs below were taken after "tweaking" was accomplished.

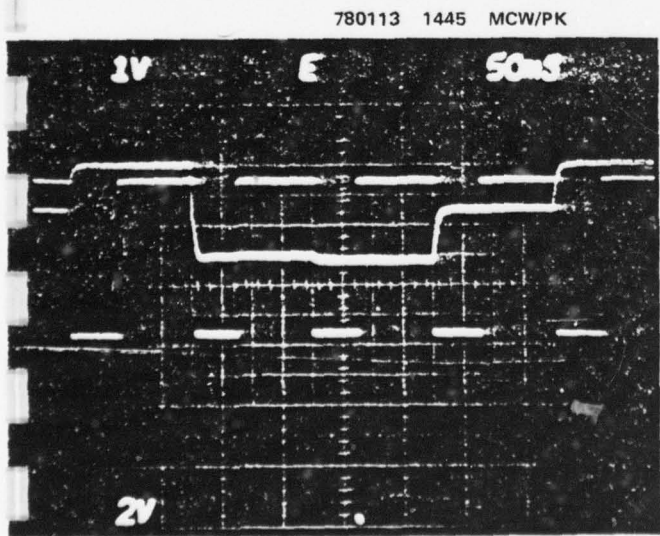

1943

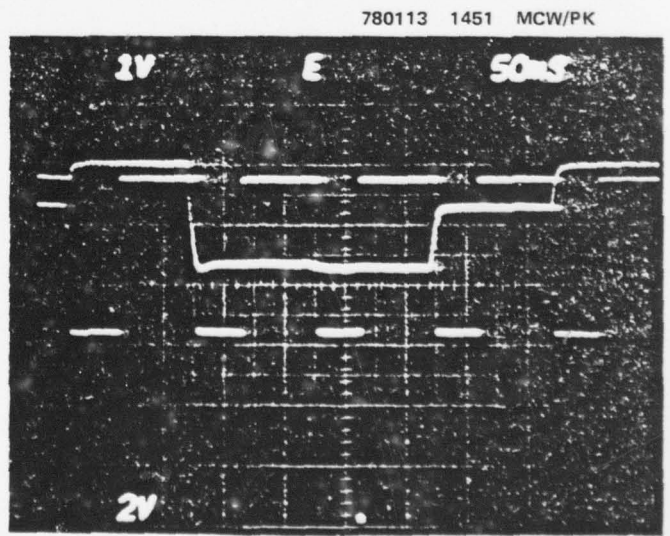

1949

780113 1543 MCW/PK

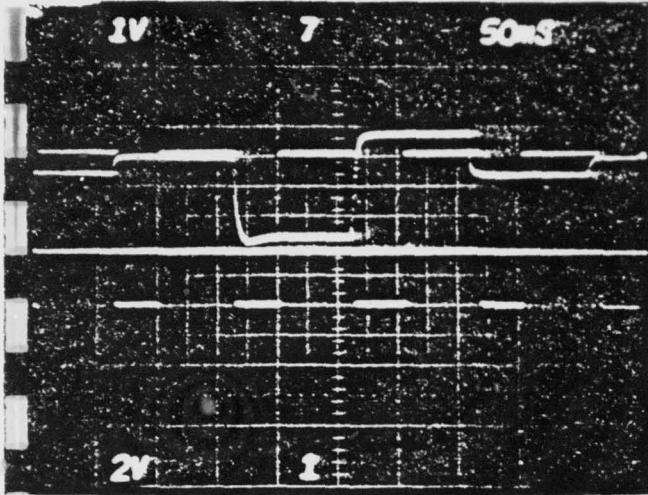

No. 1 1909:14

780113 1550 MCW/PK

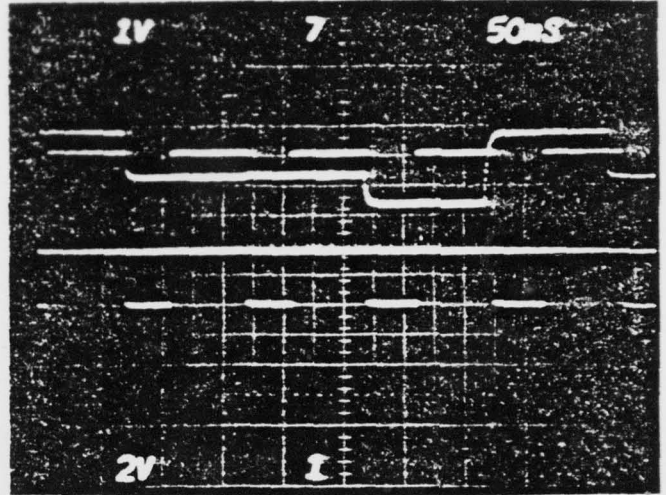

No. 2 1915:41

The above photographs were taken during the first data run. The photographs below were taken during the second data run.

780116 10:17 MCW/PK

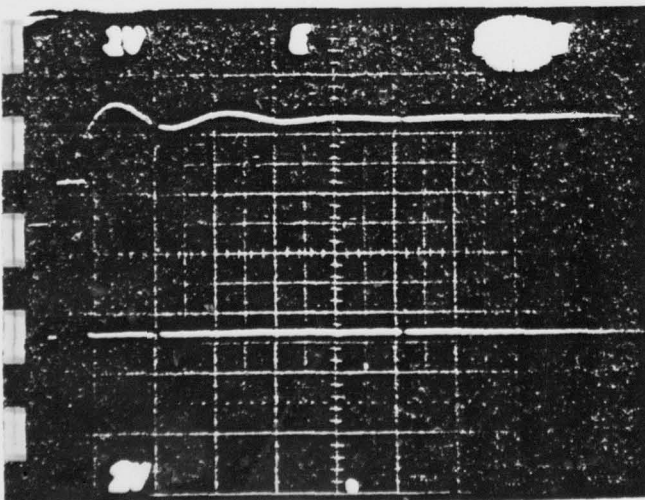

No. 1 WALLOPS No. 3 1909:42

780116 10:26 MCW/PK

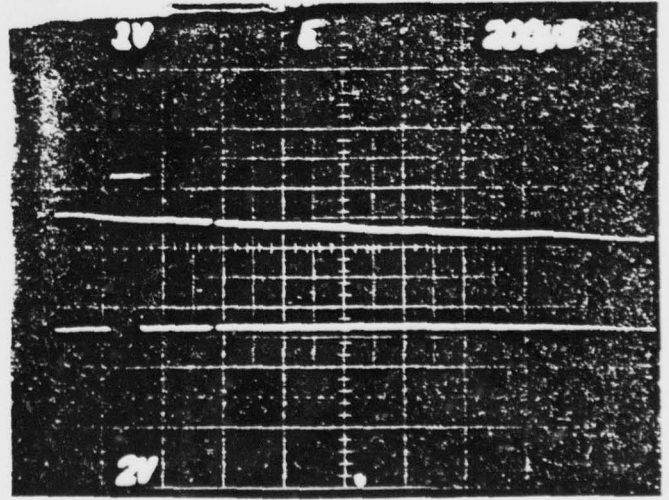

No. 2 WALLOPS No. 3 1917:33

The photographs are annotated such that the upper border contains the date and time of exposure and the lower right border contains the approximate time from the tape.

### 6.3 DATA SMOOTHING AND REDUCTION

A short investigation was made into the selection of significant period ratios for storage in the reduced data file. It has shown that the selected samples are, in general, distorted by noise somewhat more than the unselected samples. The investigation showed that three-point averaging would sufficiently reduce the noise content of the noisiest values so that the selected values would be considerably less noisy.

Another short investigation into smoothing and reduction techniques has suggested that the data might be smoothed and reduced at the same time by a series of data fittings by linear regression with a series of simultaneous equation solutions to determine the "significant" values at which trends change. While this technique shows promise of achieving good results in both the smoothing and the data reduction, it suffers from the disadvantage that it would probably require considerably more processing power to operate in near realtime. Also, there are numerous ways of implementing the linear regression technique, requiring somewhat more effort for its implementation.

As a result of the short investigations, it has been concluded that three-point averaging will significantly reduce noise with little effort required for implementation and that linear regression will provide more noise reduction with somewhat more effort for implementation.

Before it is clear whether either of these techniques should be used, the effects of noise should be evaluated.



#### 6.4 HUMIDITY CALCULATION

A new algorithm, 3.3.2(2), determines relative humidity from the humidity element's resistance ratio and air temperature. It uses an equation to replace the current common method of calculating humidity; that is, linear interpolation between data points that were determined under laboratory conditions. This algorithm, in equation form, will eliminate the noise produced by interpolation. The equation has been adapted to calculation of humidity in the breadboard analyzer and is described in paragraph 3.3.2.

Figure 6-5 contains graphs of percent relative humidity vs. resistance ratio as described by the equation (continuous curve), overlaid with the individual characteristic data points obtained from characteristic data sheet of the humidity element. The plots are on a semi-logarithmic scale and depict temperatures of -40, 0, 25, and 40 degrees Celsius respectively. Note that the greatest departure of the curves from the data points occurs where the temperature is  $-40^{\circ}\text{C}$  and the resistance ratios are less than one. This deviation is of no great concern because in regions of low temperature and low relative humidity, the absolute humidity is so small that the absolute error is minimal. Also, no attempt was made to fit the local irregularities ("wiggles") in the data because these are known to contain small departures from the humidity element's actual behavior. In view of the facts that the equation fits the data within the bounds exhibited by the "wiggles," and that new data are expected to be devoid of such irregularities, there is no object in trying to make the equation fit the data any better than it already does.

The algorithm was determined by curve fitting with the aid of the Tektronix 4051 computer system. A program was devised that will plot a desired function and then compare it with any of the characteristic curves pertaining to a given temperature. This program's listing can be found in Figure 6-6. Note that the data statements contain the characteristic data



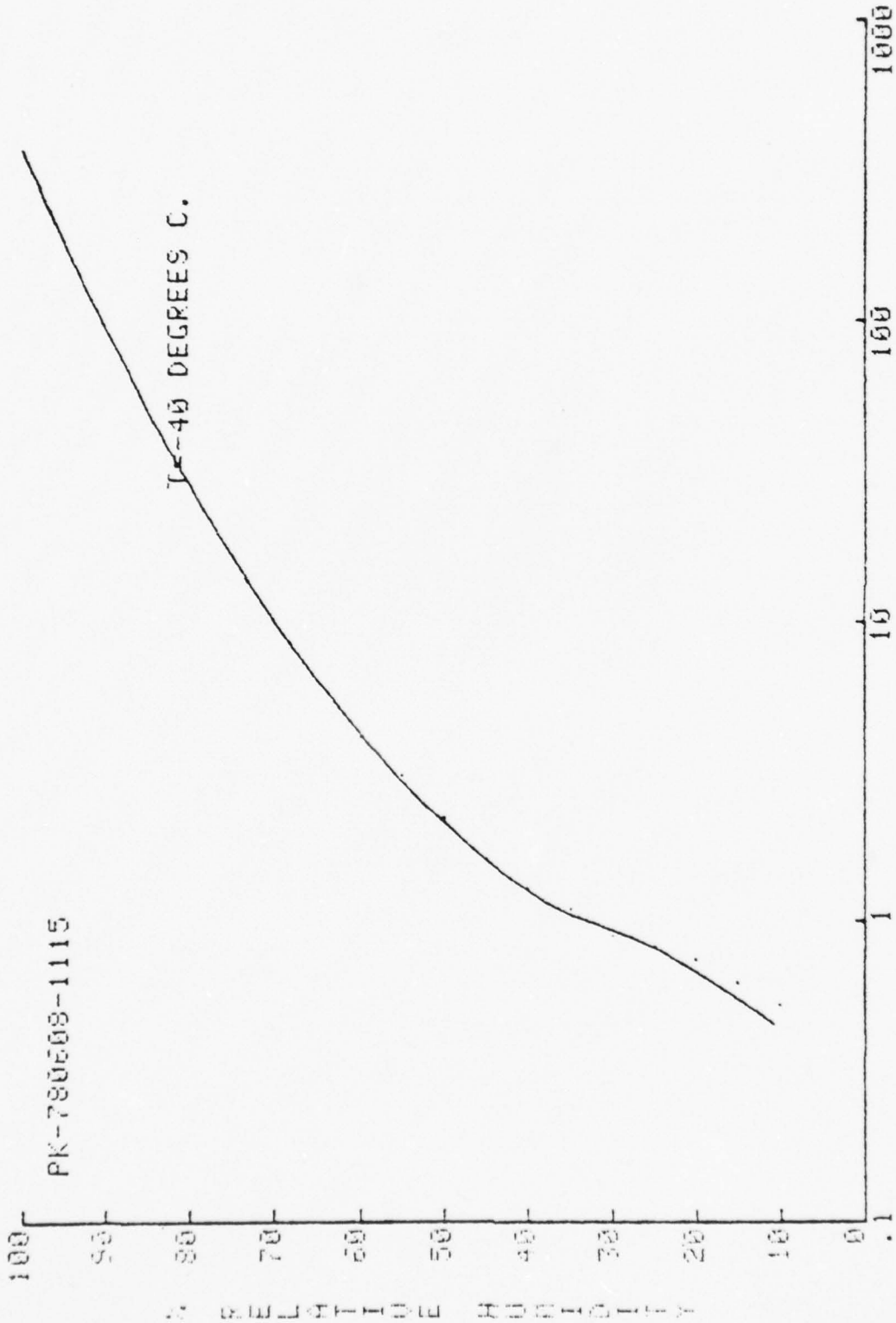

HUMIDITY ELEMENT RESISTANCE RATIO

Figure 6.5. Humidity Equation for -40° C Plotted with Calibration Points (page 1 of 4)



T=0 DEGREES C.

PK-780608-1120

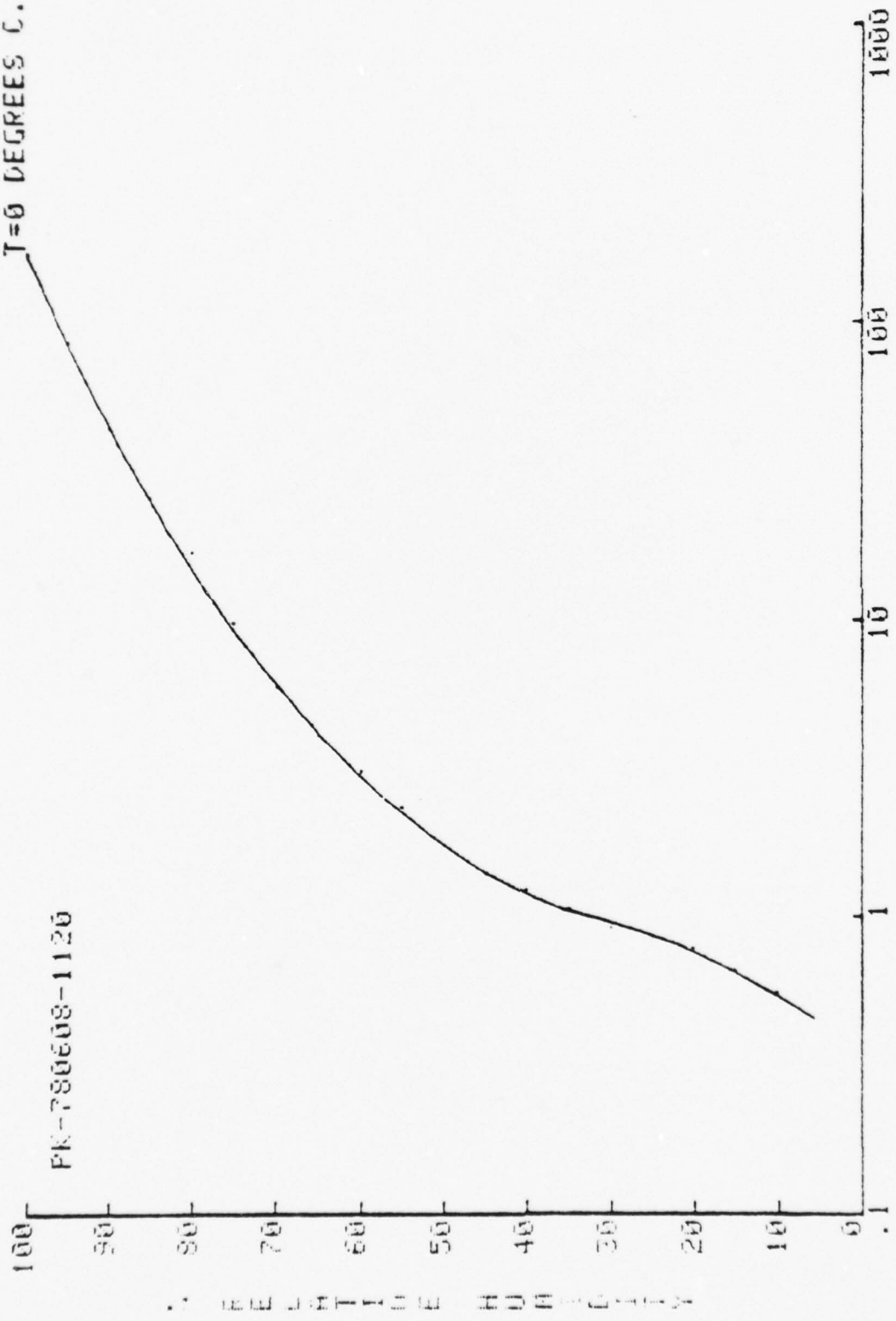

HUMIDITY ELEMENT RESISTANCE RATIO

Figure 6-5. Humidity Equation for 0° C Plotted with Calibration Points (Page 2 of 4)



T=25 DEGREES C.

PK-780608-1122

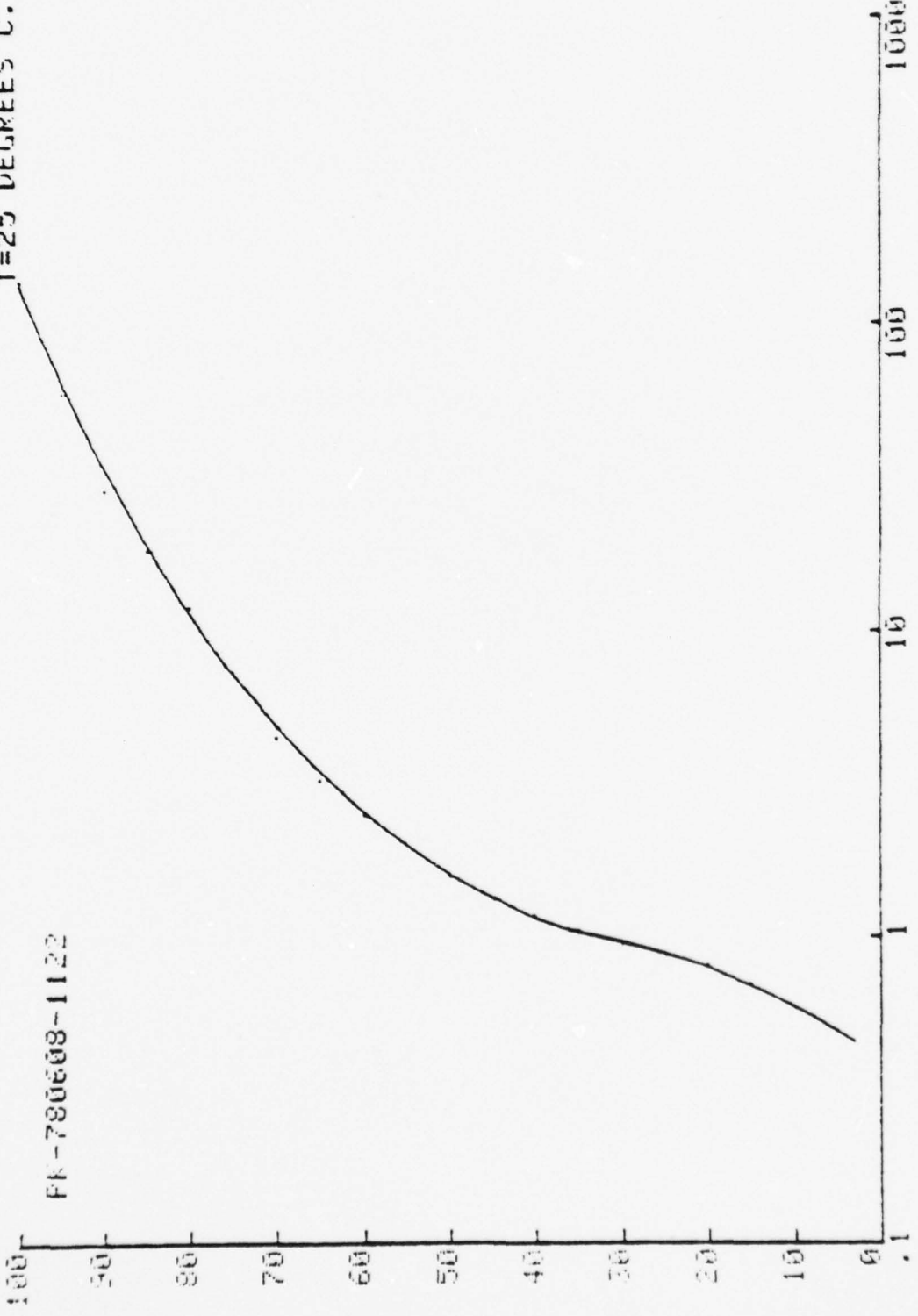

HUMIDITY ELEMENT RESISTANCE RATIO

Figure 6-5. Humidity Equation for 25°C Plotted with Calibration Points (Page 3 of 4)

RELATIVE HUMIDITY



f=40 DEGREES C.

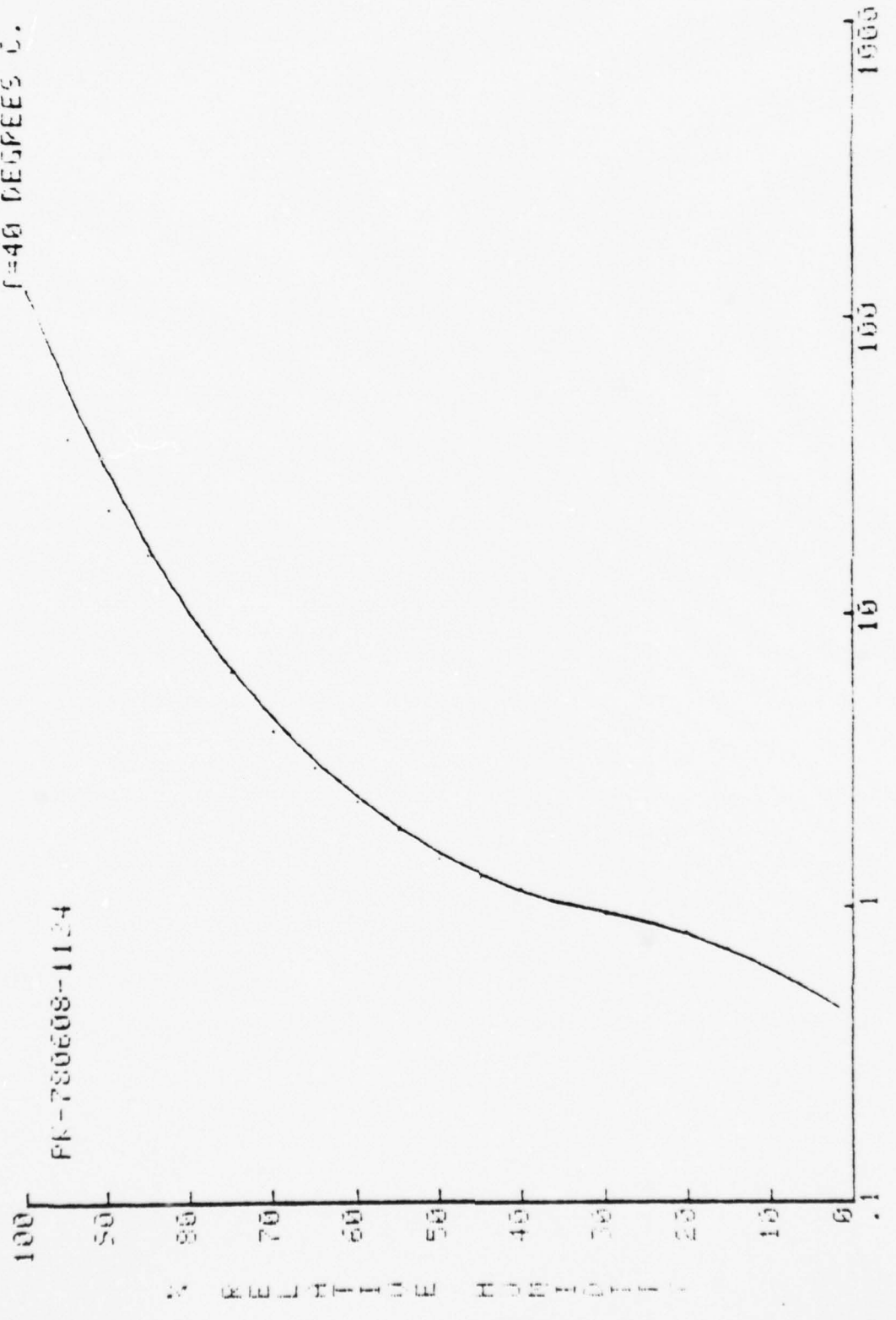

PK-780608-1124

HUMIDITY ELEMENT PERSISTENCE RATIO

Figure 6-5. Humidity Equation for 40°C Plotted with Calibration Points (Page 4 of 4)



```

50000 INIT
50010 REM-TEMPERATURE IN DEGREES C.
50020 DATA 0
50030 REM- NUMBER OF DATA POINTS.
50040 DATA 20
50050 DATA 0.52,10,0.62,15,0.74,20,0.82,25,0.9,30
50060 DATA 1,33,1.1,35,1.3,40,1.63,45,2.23,50,3.1,55,4.2,60
50070 DATA 6.5,65,10.2,70,17,75,29,80,29,80,29,80,29,80,29,80
50080 DATA 0.55,10,0.65,15,0.78,20,0.85,25,0.92,30
50090 DATA 1,33,1.06,35,1.23,40,1.4,45,1.75,50,2.35,55,3.1,60
50100 DATA 4.1,65,6,70,9.8,75,17,80,26,85,44,90,86,95,170,100
50110 DATA 0.585,10,0.695,15,0.8,20,0.875,25,0.94,30
50120 DATA 1,33,1.05,35,1.175,40,1.32,45,1.58,50,2,55,2.5,60
50130 DATA 3.25,65,4.5,70,7.3,75,12,80,18.5,85,29,90,60,95,140,100
50140 DATA 0.61,10,0.72,15,0.82,20,0.89,25,0.95,30
50150 DATA 1,33,1.04,35,1.15,40,1.27,45,1.47,50,1.85,55,2.3,60
50160 DATA 3,65,4,70,6.4,75,10,80,16,85,23,90,40,95,126,100
50170 RESTORE 50020
50180 READ T
50190 PAGE
50200 PRINT 'ENTER OPERATOR-DATE-TIME- *';
50210 INPUT Z$
50220 PAGE
50230 MOVE 15,95
50240 PRINT Z$
50250 WINDOW -1,3,0,100
50260 VIEWPORT 10,125,15,100
50270 AXIS 1,10,-1,0
50280 MOVE -1,99
50290 PRINT 'HHH100'
50300 MOVE -1,89
50310 PRINT 'HH90'
50320 MOVE -1,79
50330 PRINT 'HH80'
50340 MOVE -1,69
50350 PRINT 'HH70'
50360 MOVE -1,59
50370 PRINT 'HH60'
50380 MOVE -1,49
50390 PRINT 'HH50'
50400 MOVE -1,39
50410 PRINT 'HH40'
50420 MOVE -1,29
50430 PRINT 'HH30'
50440 MOVE -1,19
50450 PRINT 'HH20'
50460 MOVE -1,9
50470 PRINT 'HH10'
50480 MOVE -1,0
50490 PRINT 'H0'
50500 MOVE -1,100

```

Figure 6-6. Program Listing for Humidity Curve-Fitting Aid (Page 1 of 3)



```

50510 PRINT "BBBBBJJJJJJ%BJ BJRBJEJLBJABJTBJJIBJVBJE"
50520 MOVE -1,50
50530 PRINT "BBBBBJ BJHHJUBJMBJIBJDBJIBJTBJY"
50540 MOVE -1,0
50550 PRINT "JB.1"
50560 MOVE 0,0
50570 PRINT "J1"
50580 MOVE 1,0
50590 PRINT "JB10"
50600 MOVE 2,0
50610 PRINT "JBH100"
50620 MOVE 3,0
50630 PRINT "JBHH1000"
50640 MOVE -1,0
50650 PRINT "JJJ                                HUMIDITY ELEMENT RESISTANCE RATIO"
50660 MOVE LGT(1),33
50670 PRINT @41:" ",Z$
50680 PRINT @41:
50690 PRINT @41:" ", "CALCULATED HUMIDITIES FOR TEMP=";T
50700 PRINT @41:
50710 PRINT @41:" ", "RATIO", "%RH"
50720 R=0.45
50730 GOSUB 51160
50740 H=33-H9
50750 X=LGT(R)
50760 MOVE X,H
50770 FOR N9=0 TO 1000
50780 R=R*1.1
50790 IF R<1 THEN 50820
50800 GOSUB 51200
50810 GO TO 50850
50820 GOSUB 51160
50830 H=33-H9
50840 GO TO 50860
50850 H=33+H9
50860 PRINT @41:" ",R,H
50870 IF H>103 THEN 50920
50880 X=LGT(R)
50890 DRAW X,H
50900 NEXT N9
50910 RESTORE 50040
50920 READ D
50930 IF T=25 THEN 51010
50940 GO TO T/40+2 OF 50970,50990,51030
50950 LIST 50930,50940
50960 STOP
50970 RESTORE 50050
50980 GO TO 51050
50990 RESTORE 50080
51000 GO TO 51050
51010 RESTORE 50110

```

Figure 6-6. Program Listing for Humidity Curve-Fitting Aid (Page 2 of 3)



```

51020 GO TO 51050
51030 RESTORE 50140
51040 GO TO 51050
51050 FOR I=1 TO D
51060 READ R1,H1
51070 L=LGT(R1)
51080 MOVE L,H1
51090 DRAW L,H1
51100 NEXT I
51110 PRINT 'T=';T;' DEGREES C.'
51120 LIST @41:51160,51260
51130 PRINT @41:
51140 PRINT @41:' ',Z$
51150 END
51160 REM- ENTRY POINT FOR R<1.
51170 B=20
51180 R9=1/R
51190 GO TO 51230
51200 REM- ENTRY POINT FOR R=>1.
51210 B=15
51220 R9=R
51230 A=0.02*T+3.2
51240 D=0.9-(0.001425*T+0.25)*LGT(LGT(R9)+1)^0.33333333333333
51250 H9=A*LOG(R9^B)^D
51260 RETURN

```

Figure 6-6. Program Listing for Humidity Curve-Fitting Aid (Page 3 of 3)



points for the humidity element. To use the curve fitting program, enter the desired temperature in data statement 50020, and adjust the equation as desired in subroutine 51160.

#### 6.5 SYNCHRONOUS DECOMMUTATION

The Breadboard Dropsonde-MRS Analyzer currently receives its input data from a breadboard decommutator that produces a cycle sampling sequence of four strobe pulses each time a reference sample appears. Experience in processing noisy data from soundings (both drop and MRS) has shown that noise can cause faulty decommutation of the data.

Various means of improving the breadboard's performance with noisy signals have been investigated and found helpful. They include pass-band filtering, signal conditioning based on slope-level triggering and selection of low pass, high pass and triggering values based on each drop's observed signal and noise characteristic. Although these precautions provide marked improvement in the decommutator's operation, they lengthen considerably the time required to analyze data from a sounding. In addition, even with these precautions and a fairly noise-free signal, occasional cycle decommutation failures still occur.

The decommutation failures, when observed with multi-channel oscilloscope, appeared to be associated with a "noise-spike" that occurred during the reference cycle and caused double appearance and/or jittering of the reference strobes. The reference strobe malfunctions were also frequently accompanied by loss of temperature sample.

This radical behavior of the decommutator thus appears to be caused by a noise spike in a single reference sample and could probably be improved dramatically by generating the sample strobes from a fly-wheel oscillator. Such a synchronous decommutator is expected to maintain synchronization with the signal even if the signal is interrupted from several cycles.



A preliminary investigation has suggested a number of useful techniques for implementing a fly-wheel oscillator for synchronous demodulation. Among them are TV type of raster scanning oscillators, phase-locked loop, bias-controlled RC oscillators, digitized oscillators, sync-gated oscillators and S/N-adaptive integration interval.

#### 6.6 OPERATIONAL OUTPUT

Experience gained during the contract has provided some insight into output characteristics that would be effective in the operational environment.

First, it is important that a real-time output provide a basis for evaluating the sounding. If a sounding is giving nonvalid results, it is important that it be known soon so that a new sounding can be started. This could be accomplished by occasional display of temperature, humidity and pressure during sounding.

Second, it is important that the sounding provide a near real-time indication of the refraction layers that are present. This could be done by indicating the deficit, thickness and altitude for each layer considered in excess of marginal exploitability. If this display shows a significant departure from expected conditions, the sounding crew can take immediate appropriate action with respect to forwarding the information to the platform commander, to E/WEPS, etc. Printout of this information is desirable to expedite forwarding and utilization of the information.

Third, it is important that a post-sounding refractivity profile be transferred into E/WEPS as soon as possible. An electrical transfer between I/O ports of the recorder-analyzer and E/WEPS using ASCII is contemplated, based on preliminary agreement with E/WEPS development staff at Navy Ocean Systems Center (NOSC).



Fourth, fifth and sixth; the sounding results are needed by the local Navy Meteorological Unit (NMU) for updating its weather information, by FNWC for inclusion in its predictions and data dissemination services and by archives for research and development activities. Ballistic winds can also be calculated when the wind option is included. The Navy Environmental Display Station appears to be the most logical means of passing the sounding results to these three users. An ASCII transfer to NEDS of significant and mandatory levels of temperature, pressure and dew point depression in WMO format appears the best way of accomplishing these three outputs, since NEDS has the communication facilities for all three users.

## 6.7 ANALYSIS ALGORITHM IMPROVEMENTS

### 6.7.1 Smoothing of Calculated M-Unit Values

An adaptation of significant values selection is seen as a good means of representing the M-units profile in a noise-smoothed manner. It is believed that the noise excursions can be smoothed to obtain a virtually zero false alarm rate since the "minimum exploitable duct" has been defined as having fairly large dimensions. Thus the refractive layers selector can look for fairly large effects that are not likely to be masked by noise. Such a refractive layer selector could be adapted for operation with all of the outputs described in paragraph 6.6.

### 6.7.2 Classification of Refractivity Gradients

Some research into this classification activity is needed. It is not clear who needs this information, or why. There is a great deal of latitude on interpretation of how the classification should be performed, but these classifications, by themselves, don't appear very useful. If the classification processing can be eliminated, it would result in a significant simplification of the analyzer.



### 6.7.3 Pressure-Based Analysis

The introduction of CAPS provides an essentially continuous record of atmospheric measurements which suggests that pressure or some function of pressure, instead of time, might be used as the "measuring stick" during analysis. For example, data smoothing and reduction might be accomplished by two analyses instead of three: temperature vs. pressure and humidity vs. pressure instead of temperature vs. time and pressure vs. time and humidity vs. time. Elimination of time would also reduce the volume of data to be stored.

### 6.7.4 Humidity Calculations Improvement

Improved humidity elements are expected to become available in the near future. They are expected to have more accuracy and repeatability and less hysteresis than the present elements. Also, improved data for the present elements is expected soon. It is believed the new data will provide a better fit to the element's actual performance. It is expected that the humidity equation's coefficients can be adjusted, if appropriate, to give a good fit of the new data.

### 6.7.5 Improvement of $e_s$ Calculation

It is believed, based on short investigation, that the calculation of saturated water vapor pressure,  $e_s$ , could be simplified considerably while still preserving accuracy through about 4 digits.

### 6.7.6 Calculation of CAPS-Measured Pressure

The CAPS pressure equation was produced using classical curve fitting techniques of general utility. Curve-fitting experience has shown that a customized approach for a specific type of device usually provides a simpler expression which can be calculated more rapidly in a computer. It is expected that the pressure equation could be simplified significantly by a customized curve fitting approach.



## 6.8 SPECIAL TOPICS

### 6.8.1 Humidity Accuracy Effects

Humidity plays a large role in determining refractivity of the air. However, humidity is the parameter that is measured with least accuracy. Improvements in humidity accuracy are expected to make significant improvements in the ability to analyze refractivity effects. Because the humidity elements' output can legitimately change very rapidly, it is more difficult to discriminate against noise than it is with other sensors. Investigation of actual sounding data has shown that special measures must be taken in the case of humidity elements. Rate discrimination has been applied in addition to value discrimination. Further improvement is probably possible and may be desirable.

### 6.8.2 Surface Measurements

In the case of a refractivity layer near the surface, it is not possible to know whether the layer's effect extends to the surface unless the surface values and some intermediate values are known. Thus the measurement of surface values takes on a special value. It is particularly difficult in the case of a dropsonde to know if the end of the received data is actually the time of splash. If there are several seconds missed, an important refractivity layer could be missed as well.

But the problem is not limited to dropsondes. If a balloon-sonde is launched from a distance of 40 to 60 feet above water, it will also be difficult to determine whether or not a near-surface effect actually extends down to the surface.

### 6.8.3 Wet Sensors

Wetting of sensors by rain or fine droplets can cause a problem since errors in temperature and humidity measurement can occur. Some attention has been given to this subject and more understanding is needed.



## 7. CONCLUSIONS AND RECOMMENDATIONS

Use of the analyzer for processing of sounding data and for evaluation of operational equipment has identified a number of problems. In general, the analysis-associated problems fall into two major categories, being caused by noise or processing load, as discussed in Sections 7.1 and 7.2.

Some problems not affected by analysis, but meriting attention, are identified in Section 7.3.

### 7.1 ANALYSIS TECHNIQUES FOR NOISE-EFFECTS REDUCTION

A number of noise effects have been observed, including loss of decommutator synchronization, period measurement errors, selection of noisy period-ratios as "significant," degraded noise discrimination in gap processor and small random-appearing variations in the output plots and reports.

Some of the possible solutions for these problems are attractive because they promise effectiveness by improving performance substantially with little cost. They are enumerated as recommendations in the paragraphs that follow.

#### 7.1.1 Noise-Rejection Filtering

Filtering is recommended for rejection of noise outside the passbands occupied by the reference and data signals. To improve the marking of cycles for period measurement and thus reap further benefits from filtering, a symmetrical waveshape is recommended to reduce harmonic content and zero cross-over detection is recommended to reduce extraneous cycle marks.



#### 7.1.2 Improvement of Decommulation Synchronization

An improved flywheel oscillator is recommended for driving the decommutator, and improved triggering is recommended for maintaining oscillator synchronization through short periods of signal interruption. Pattern correlation with integration over a number of sample intervals is recommended for trigger improvement.

#### 7.1.3 Significant Ratios Noise Smoothing

Short-interval averaging, in the order of three to six points, is recommended as a means of reducing the effects of noise in the selection of significant ratios. Rejection of noisy (large deviation) samples before averaging is recommended.

#### 7.1.4 Gap-Processor Rate-Based Noise Discrimination

Rate-based noise discrimination is recommended for the gap processor to permit restoration of signals that have potential for change in excess of noise during a signal interruption.

#### 7.1.5 Interpolative Noise Reduction

Calculation of humidity by equation is recommended instead of by table lookup with interpolation. The equation method of calculation virtually eliminates errors caused by interpolation. These errors can have a noise-like appearance in the analysis output.

#### 7.1.6 Adjustment of Report Resolution to Exploitation Threshold

Adjustment of sampling resolution in reporting is recommended to achieve close correspondence to recently identified thresholds for exploitation of refractive effects. This will increase the interval between reported samples and cause a noise reduction relative to the refraction change in the increased intervals, without compromising the ability to report exploitable refractive effects.



## 7.2 ANALYSIS TECHNIQUES FOR PROCESSING-LOAD REDUCTION

The analyzer's processing time for a sounding is roughly an hour or more, depending upon the drop length and number of "significant" period ratios selected for processing. The processing is slow because the programming language is BASIC and is interpreted "on the fly" by the Tektronix 4051 computer.

Although the processing is slow, it is very good for exploration of processing simplifications because of its ease of reprogramming. The following recommendations are directed toward making significant reductions in the analyzer's processing time and identifying simplifications that can be incorporated in the operational equipment for reduction of its processing load.

### 7.2.1 Sample Count Reduction

A reduction in the number of samples to be processed is recommended for the reduction of processing load. For good effectiveness, the reduction should be made early with little processing required and should be as great as possible without compromising the detectability of exploitable refractive effects or the accuracy needed for the normal weather analysis.

Linear regression applied to averaged values with trend change detection is recommended as a candidate technique for development because of its excellent smoothing characteristics. Further, its application in a suitably transformed data space is recommended as a potential means of achieving maximum sample count reduction without compromising the accuracy and with possible identification of doubtful and missing data. The transformed data space could be based on pressure as described in Section 6.7.3.

In this method, the reduced samples would be determined by simultaneous solution of the intersecting trend equations.



## 7.2 ANALYSIS TECHNIQUES FOR PROCESSING-LOAD REDUCTION

The analyzer's processing time for a sounding is roughly an hour or more, depending upon the drop length and number of "significant" period ratios selected for processing. The processing is slow because the programming language is BASIC and is interpreted "on the fly" by the Tektronix 4051 computer.

Although the processing is slow, it is very good for exploration of processing simplifications because of its ease of reprogramming. The following recommendations are directed toward making significant reductions in the analyzer's processing time and identifying simplifications that can be incorporated in the operational equipment for reduction of its processing load.

### 7.2.1 Sample Count Reduction

A reduction in the number of samples to be processed is recommended for the reduction of processing load. For good effectiveness, the reduction should be made early with little processing required and should be as great as possible without compromising the detectability of exploitable refractive effects or the accuracy needed for the normal weather analysis.

Linear regression applied to averaged values with trend change detection is recommended as a candidate technique for development because of its excellent smoothing characteristics. Further, its application in a suitably transformed data space is recommended as a potential means of achieving maximum sample count reduction without compromising the accuracy and with possible identification of doubtful and missing data. The transformed data space could be based on pressure as described in Section 6.7.3.

In this method, the reduced samples would be determined by simultaneous solution of the intersecting trend equations.



### 7.2.2 Sample Processing-Time Reduction

Reduction of the sample processing-time by simplification of algorithms is recommended as a further means of reducing the processing load. The following algorithms are candidates for simplification:

- Calculation of saturated water vapor pressure.
- Calculation of pressure.
- Calculation of dew point depression.
- Calculation of layer thickness.

### 7.2.3 Storage of Values Having Multiple Application

Some values are calculated whenever needed to reduce the amount of memory dedicated to data storage. The reduction of sample count should make some memory available for storage of additional calculated data. Thus, storage of calculated data is recommended to eliminate the need for recalculation.

### 7.2.4 Report Simplification

Restructuring of the output reports is recommended to reduce the processing load associated with reporting. This restructuring would follow the guidelines in Section 6.6 of this report and would include new features as their need is identified.

The present understanding of requirements suggests that the reporting load can be reduced to considerably less than half and that more useful reports can be obtained, including, for example, an index of normalized propagation path curvature that would be of immediate benefit to an air crew receiving the report.

### 7.2.5 Effectiveness Investigation

Although each of the recommendations for reducing processing load will improve performance, some will be more effective than others. A preliminary investigation is recommended to rank their effectiveness and establish priorities for implementation.



### 7.3 OTHER RECOMMENDATIONS

#### 7.3.1 Baroswitch Operations

If baroswitch pressure measurements are implemented in operational soundings, some precautions are recommended. "Make-detection" in preference to "break-detection" is recommended in drop as well as balloon sounding, because makes have been observed to be "cleaner" than breaks. The new linear type of baroswitch is recommended in preference to the old type for more accurate measurement by make-detection in dropsoundings and a new baseline procedure is recommended to accommodate the change from break-detection to make-detection.

Also, if baroswitch measurements are implemented for dropsoundings, a qualification program is recommended to assure that the baroswitch baseline is being maintained through the shock and accelerations of handling and launch. Finally, if baroswitch is implemented, inclusion of the redundancy eliminator is recommended to simplify calibration.

#### 7.3.2 Humidity Measurements

If the new type humidity element in development is judged satisfactory by preliminary tests, qualification testing is recommended to include evaluation of accuracy, hysteresis effects, cycling effects, speed of response, and adaptability to automatic humidity calculation.

#### 7.3.3 Wet Sensors Effects

Short tests in the laboratory for the purpose of establishing humidity rate limits have shown that humidity measurements are "super-humid" when the element becomes wet. This can cause a cloud to appear thicker than it really is. In addition, it is expected that temperature measurements will be low due to evaporative cooling while the thermistor is drying. Temperature measurements are also likely to have additional lag due to the thermal capacity of the water on the thermistor.



There is no known way of compensating for these wet sensor effects. Design efforts to prevent or restrict wetting are recommended.

#### 7.3.4 Deferred Reporting of Operational Soundings

In the case of the airborne processor, three or four soundings might be obtained in the course of a mission. Each sounding's last report from the processor, intended for surface-based analysis operations, is recommended for retention in the processor's memory, to permit quick access to the data after the mission and without requiring reprocessing.

#### 7.3.5 Near-Surface Measurements

The near-surface portion of the atmospheric profiles is of vital concern and is subject to misinterpretation if measured in a manner not consistent with the rest of the profile. Study of near-surface measurement techniques is recommended for both dropsoundings and balloonsoundings.

Splash detection would be a valuable aid in drop sounding analysis, and near-surface (within roughly 10 feet) launch or simulated launch would be a valuable aid in analyzing soundings by the minirefractiionsonde.



APPENDIX A  
ANALYSIS EXAMPLE FOR BAROSWITCH DROPSONDE



APPENDIX A  
ANALYSIS EXAMPLE FOR BAROSWITCH DROPSONDE

The Baroswitch Dropsonde program on cassette V was operated on 23 September 1977, shortly after its completion, and its results were given immediately to NADC for examination and evaluation. It was used to process data from 1976 Test Drop No. 1 off the Atlantic City coast on 5 August 1976. This appendix illustrates the Baroswitch Dropsonde data processing operations by presenting that drop's computer-generated displays and printouts that are peculiar to Baroswitch Dropsonde.

The calibration and analysis displays are not shown here because of their similarity to those obtained with the CAPS Dropsonde program example illustrated in Appendix B. The only difference is the entry of calibration data as directed in detail by the display.

The analysis portion of the processing is different from the CAPS Dropsonde only when the pressure table is being built. Therefore, that portion of the analysis is illustrated here. Figure A-1 shows the display of baroswitch calibration data produced by the computer after being directed by the operator to perform analysis in preference to calibration and acquisition and after reading the calibration data from the cassette file selected by the operator.

Figure A-2 shows the computer printout of the drop's pressure table obtained by look up of pressure values in the calibration table after detection and identification of contact breaks. The tables' values are composed of time tag in deciseconds in the integer portion of each value and of pressure in dekabars in the decimal portion of each value.



REFRACTION DROPSONDE DATA ANALYZER -- NADC AUTO

ENTER PROG SELECTION 1 OR 2: 1-CAL&ACC 2-ANALYSIS -- 2  
 WILL READ DATA ANALYSIS PROG FROM INTERNAL CASSETTE FILE 2  
 ENTER R WEN RDY -- R  
 LOAD "SAFE" DATA CASSETTE INTO CONSOLE. ENTER FILE NOS. OF  
 CALIBRATION AND DATA FILES TO BE PROCESSED (CC DD) -- 22 21  
 BAROSW TAPE HDR: 999 99 105 9642 50 0 9797 (CHECK SER. NO.)  
 ENTER + IF OK & RDY TO PROCEED --- +

0	0.0	1064.0	1052.0	1040.0	1029.3	1017.3	1003.3	991.0	980.3	969.3
10	59.3	945.3	934.3	923.0	912.3	901.3	888.3	877.3	867.3	856.3
20	87.3	833.3	823.3	813.0	803.3	793.3	781.3	771.3	761.3	751.3
30	74.3	733.3	723.3	714.0	705.3	696.3	685.3	676.3	667.3	658.3
40	55.3	539.3	530.3	521.0	513.3	505.3	495.3	487.3	480.3	472.3
50	54.3	547.3	539.3	531.0	524.3	516.3	515.3	507.3	500.3	493.3
60	48.3	478.3	471.3	463.0	457.3	450.3	441.3	434.3	429.3	421.3
70	41.3	405.3	400.3	393.0	387.3	381.3	375.3	369.3	365.3	357.3
80	35.3	343.3	339.3	332.0	327.3	321.3	314.3	308.3	305.3	297.3
90	29.3	287.3	282.3	276.0	271.3	265.3	259.3	255.3	250.3	245.3
100	24.3	235.3	231.3	226.0	221.3	216.3	210.3	207.3	202.3	197.3
110	19.3	191.3	187.3	183.0	179.3	175.3	171.3	167.3	164.3	160.3
120	15.3	153.3	149.3	146.0	142.3	139.3	135.3	132.3	129.3	125.3
130	11.3	119.3	116.3	113.0	110.3	107.3	104.3	100.3	97.3	94.3
140	8.3	87.3	84.3	82.0	79.3	76.3	73.3	69.3	67.3	64.3
150	5.3	58.3	55.3	53.0	50.3	47.3	44.3	42.3	39.3	36.3
160	3.3	31.3	29.3	28.0	26.3	24.3	23.3	21.3	19.3	18.3
170	7.3	4.3	1.3	0.0	0.0	0.0	0.0	0.0	0.0	0.0
180	0.0	0.0	0.0	6870.6	0.0	0.0	0.0	0.0	0.0	0.0

CAL FILE OPR-DATE CODE = NCW770629

PRESSURE SUM = 66870.6 (CK SUM OK)

ENTER TIME INTERVAL (SEC.) FROM LAUNCH TO XMITTER ON -- 1  
 FOR AUTOCOPY&PAGE, ENTER 1; AUTOPAGE ONLY, 2; NEITHER, 3 -- 3  
 SELECT DATA SOURCE: 1=PACKED FILE, 2=REDUCED FILE -- 1  
 1.0021813 1.00163988993 2.00282659998 3.  
 00384532 3.00282929998 4.00368407 5.00

Figure A-1. Display of Baroswitch Calibration Data





Figures A-3 and A-4 show the processing results as graphic presentations of altitude profiles for temperature and humidity and for refractivity (N-units) and modified refractivity (M-units).



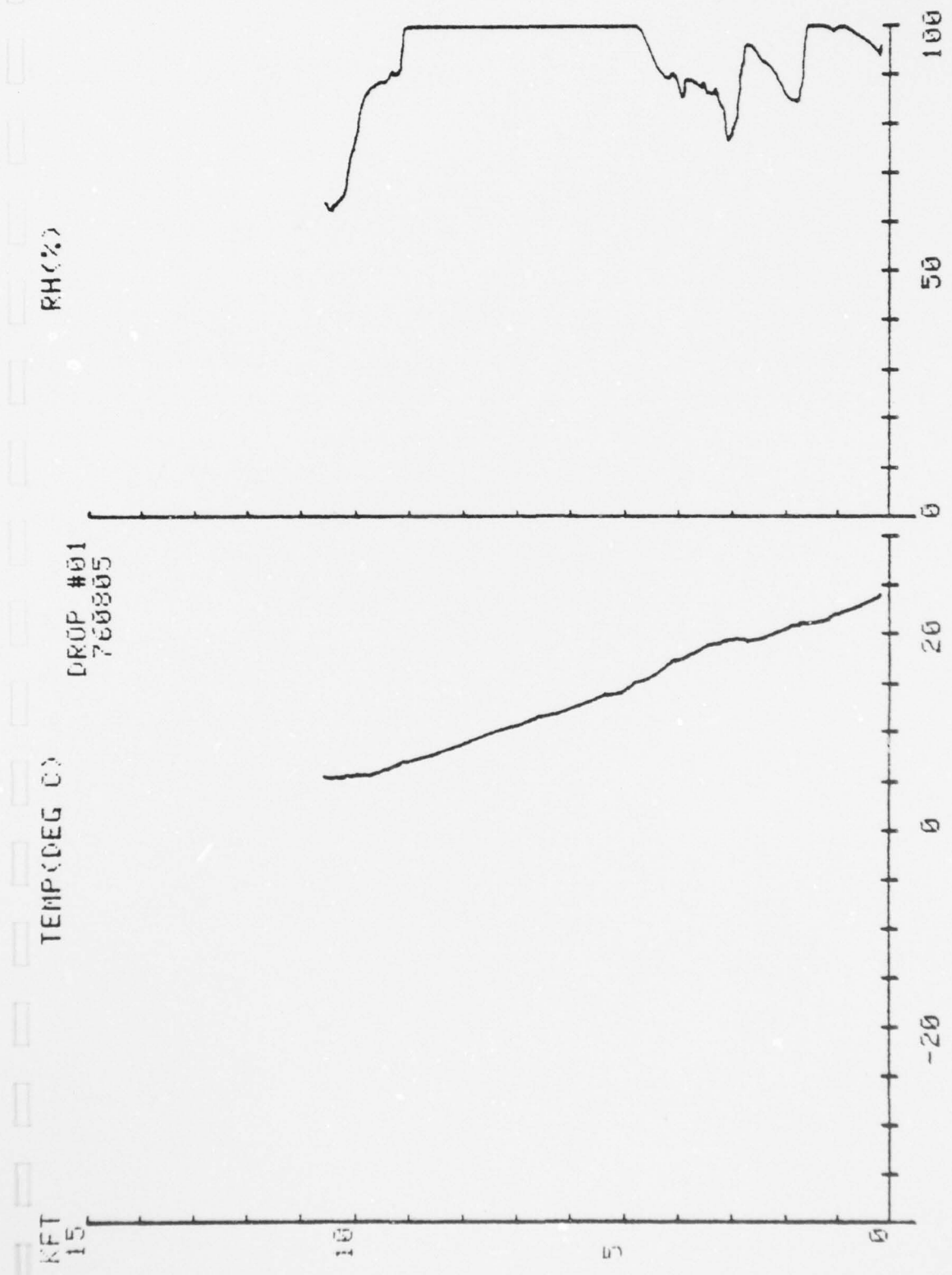

Figure A-3. 1976 Drop No. 1 Profiles of Temperature and Humidity



AD-A062 397

ANALYTICS INC WILLOW GROVE PA  
BREADBOARD DROPSONDE-MINIREFRACTIONSONDE ANALYZER. VOLUME 1.(U)  
NOV 78 M C WERST

F/G 4/1

N62269-77-C-0095

UNCLASSIFIED

NADC-76335-30

NL

2 OF 3  
ADA  
062397

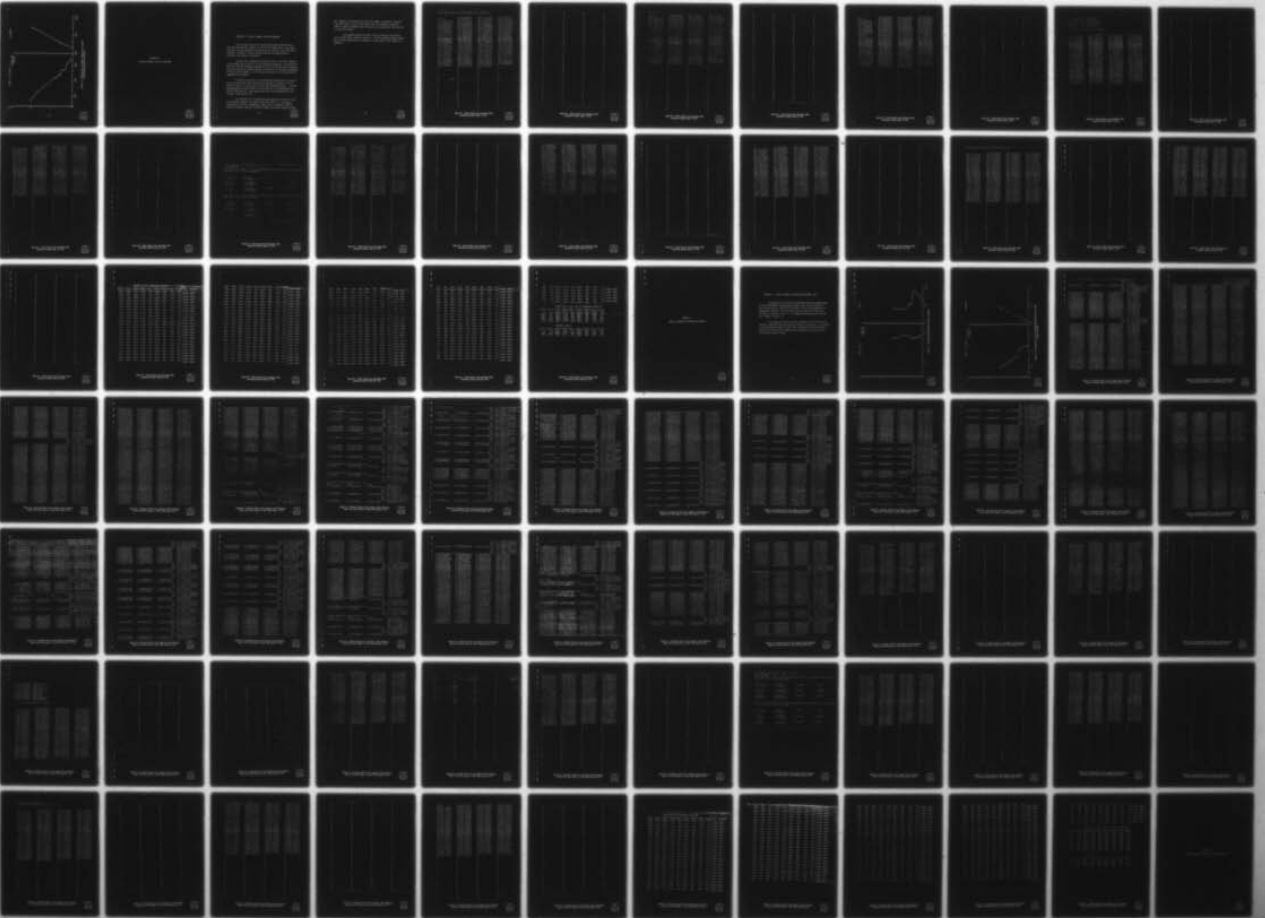

2 OF  
ADA

3

062397

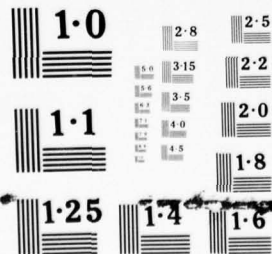

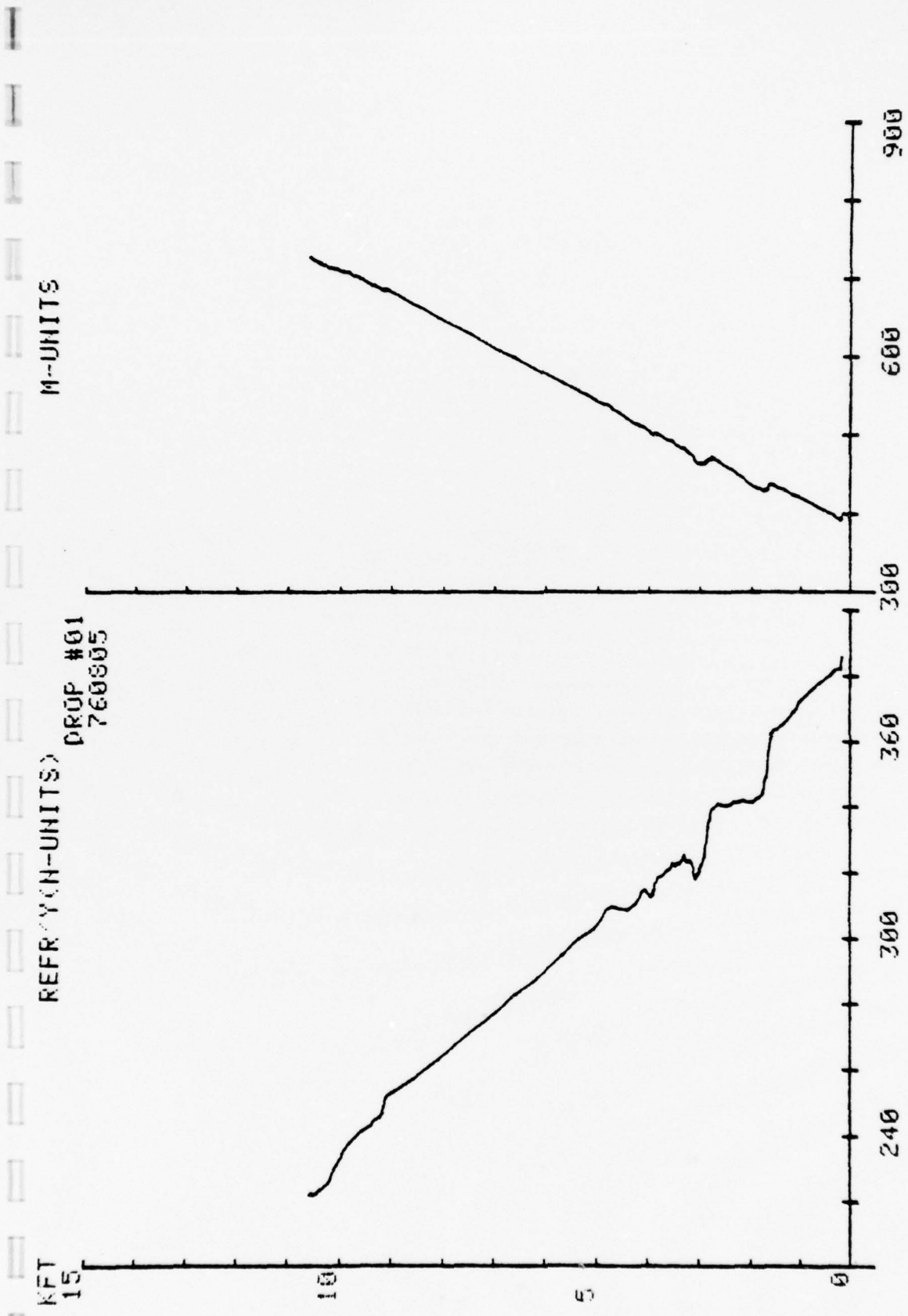

Figure A-4. 1976 Drop No. 1 Profiles of Refractivity in N-Units and Modified Refractivity in M-Units



APPENDIX B  
ANALYSIS EXAMPLE FOR CAPS DROPSONDE



## APPENDIX B. ANALYSIS EXAMPLE FOR CAPS DROPSONDE

The calibration portion of the CAPS Dropsonde program has been used and found operable; however, at the time of preparation of this report, there were no data available for acquisition and analysis from a CAPS drop-sounding. Therefore, the CAPS program operation was demonstrated by analytical and simulation techniques.

The four-level commutation and sampling rate of the CAPS dropsonde in the program are the same as for the baroswitch dropsonde. The acquisition portion of the CAPS Dropsonde program was taken from the Baroswitch Dropsonde. Since the acquisition program operates satisfactorily for baroswitch dropsonde and has not been changed, it will operate satisfactorily for the identically-commuanted CAPS Dropsonde.

The analysis portions of the program were demonstrated to be operative by using the San Diego minirefraction sounding to simulate a file of packed raw data as an input source for the CAPS Dropsonde analysis. The CAPS dropsonde analysis outputs were virtually identical to those obtained from the San Diego analysis: they agreed within the limits expected due to differences in data acquisition.

The simulated file of packed data was produced by using the following techniques combined in a single "data acquisition" run: the tape of recorded data (receiver's demodulated output) was run backward instead of forward to simulate "descent" instead of ascent; the spatial sampling density



was "reduced" by accepting only every third sample to simulate a "descent" rate three times as great as the ascent rate; the commutation sequence reversal caused by backward play of tape was also corrected by the selection of every third sample.

The computer-produced printout from the simulation and analysis run of 31 May 1978 is shown in Figure B-1. The CRT-displayed graphic outputs were found by comparison to be identical to those shown in the figures of Appendix C.







**Figure B-1. Printer Output from Simulated CAPS Dropsonde Analysis (Page 2 of 30)**



11	6.621221530005	214.6566094509	116.99080016
1264.999	166.0008118863	172.0009111881	179.64786816
1380.64646869	184.6570668966	190.6578933811	194.6008149782
1501.000910884	206.0009111881	210.0009111881	216.6494168900
1618.660990895	228.64646869	230.640990895	236.64646869
1736.000816895	251.0009110798	250.641990895	256.64646869
1854.000816895	273.594441895	270.641990895	276.64646869
1972.000816895	296.0009111881	290.641990895	296.64646869
2090.000816895	318.594441895	310.641990895	316.64646869
2208.000816895	341.0009111881	330.641990895	336.64646869
2326.000816895	363.594441895	350.641990895	356.64646869
2444.000816895	386.0009111881	370.641990895	376.64646869
2562.000816895	408.594441895	390.641990895	396.64646869
2680.000816895	431.0009111881	410.641990895	416.64646869
2798.000816895	453.594441895	430.641990895	436.64646869
2916.000816895	476.0009111881	450.641990895	456.64646869
3034.000816895	498.594441895	470.641990895	476.64646869
3152.000816895	521.0009111881	490.641990895	496.64646869
3270.000816895	543.594441895	510.641990895	516.64646869
3388.000816895	566.0009111881	530.641990895	536.64646869
3506.000816895	588.594441895	550.641990895	556.64646869
3624.000816895	611.0009111881	570.641990895	576.64646869
3742.000816895	633.594441895	590.641990895	596.64646869
3860.000816895	656.0009111881	610.641990895	616.64646869
3978.000816895	678.594441895	630.641990895	636.64646869
4096.000816895	701.0009111881	650.641990895	656.64646869
4214.000816895	723.594441895	670.641990895	676.64646869
4332.000816895	746.0009111881	690.641990895	696.64646869
4450.000816895	768.594441895	710.641990895	716.64646869
4568.000816895	791.0009111881	730.641990895	736.64646869
4686.000816895	813.594441895	750.641990895	756.64646869
4804.000816895	836.0009111881	770.641990895	776.64646869
4922.000816895	858.594441895	790.641990895	796.64646869
5040.000816895	881.0009111881	810.641990895	816.64646869
5158.000816895	903.594441895	830.641990895	836.64646869
5276.000816895	926.0009111881	850.641990895	856.64646869
5394.000816895	948.594441895	870.641990895	876.64646869
5512.000816895	971.0009111881	890.641990895	896.64646869
5630.000816895	993.594441895	910.641990895	916.64646869
5748.000816895	1016.0009111881	930.641990895	936.64646869
5866.000816895	1038.594441895	950.641990895	956.64646869
5984.000816895	1061.0009111881	970.641990895	976.64646869
6102.000816895	1083.594441895	990.641990895	996.64646869
6220.000816895	1106.0009111881	1010.641990895	1016.64646869
6338.000816895	1128.594441895	1030.641990895	1036.64646869
6456.000816895	1151.0009111881	1050.641990895	1056.64646869
6574.000816895	1173.594441895	1070.641990895	1076.64646869
6692.000816895	1196.0009111881	1090.641990895	1096.64646869
6810.000816895	1218.594441895	1110.641990895	1116.64646869
6928.000816895	1241.0009111881	1130.641990895	1136.64646869
7046.000816895	1263.594441895	1150.641990895	1156.64646869
7164.000816895	1286.0009111881	1170.641990895	1176.64646869
7282.000816895	1308.594441895	1190.641990895	1196.64646869
7400.000816895	1331.0009111881	1210.641990895	1216.64646869
7518.000816895	1353.594441895	1230.641990895	1236.64646869
7636.000816895	1376.0009111881	1250.641990895	1256.64646869
7754.000816895	1398.594441895	1270.641990895	1276.64646869
7872.000816895	1421.0009111881	1290.641990895	1296.64646869
7990.000816895	1443.594441895	1310.641990895	1316.64646869
8108.000816895	1466.0009111881	1330.641990895	1336.64646869
8226.000816895	1488.594441895	1350.641990895	1356.64646869
8344.000816895	1511.0009111881	1370.641990895	1376.64646869
8462.000816895	1533.594441895	1390.641990895	1396.64646869
8580.000816895	1556.0009111881	1410.641990895	1416.64646869
8698.000816895	1578.594441895	1430.641990895	1436.64646869
8816.000816895	1601.0009111881	1450.641990895	1456.64646869
8934.000816895	1623.594441895	1470.641990895	1476.64646869
9052.000816895	1646.0009111881	1490.641990895	1496.64646869
9170.000816895	1668.594441895	1510.641990895	1516.64646869
9288.000816895	1691.0009111881	1530.641990895	1536.64646869
9406.000816895	1713.594441895	1550.641990895	1556.64646869
9524.000816895	1736.0009111881	1570.641990895	1576.64646869
9642.000816895	1758.594441895	1590.641990895	1596.64646869
9760.000816895	1781.0009111881	1610.641990895	1616.64646869
9878.000816895	1803.594441895	1630.641990895	1636.64646869
10000.000816895	1826.0009111881	1650.641990895	1656.64646869

Figure B-1. Printer Output from Simulated CAPS  
Dropsnde Analysis (Page 3 of 30)



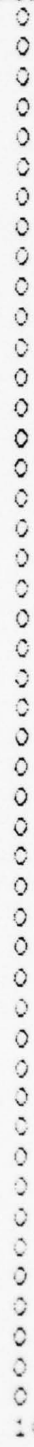
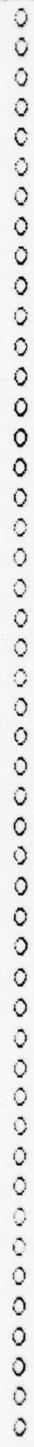
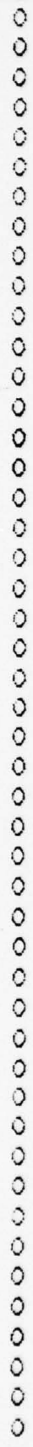

107

**Figure B-1. Printer Output from Simulated CAPS  
Dropsonde Analysis (Page 4 of 30)**







**Figure B-1. Printer Output from Simulated CAPS Dropsonde Analysis (Page 6 of 30)**





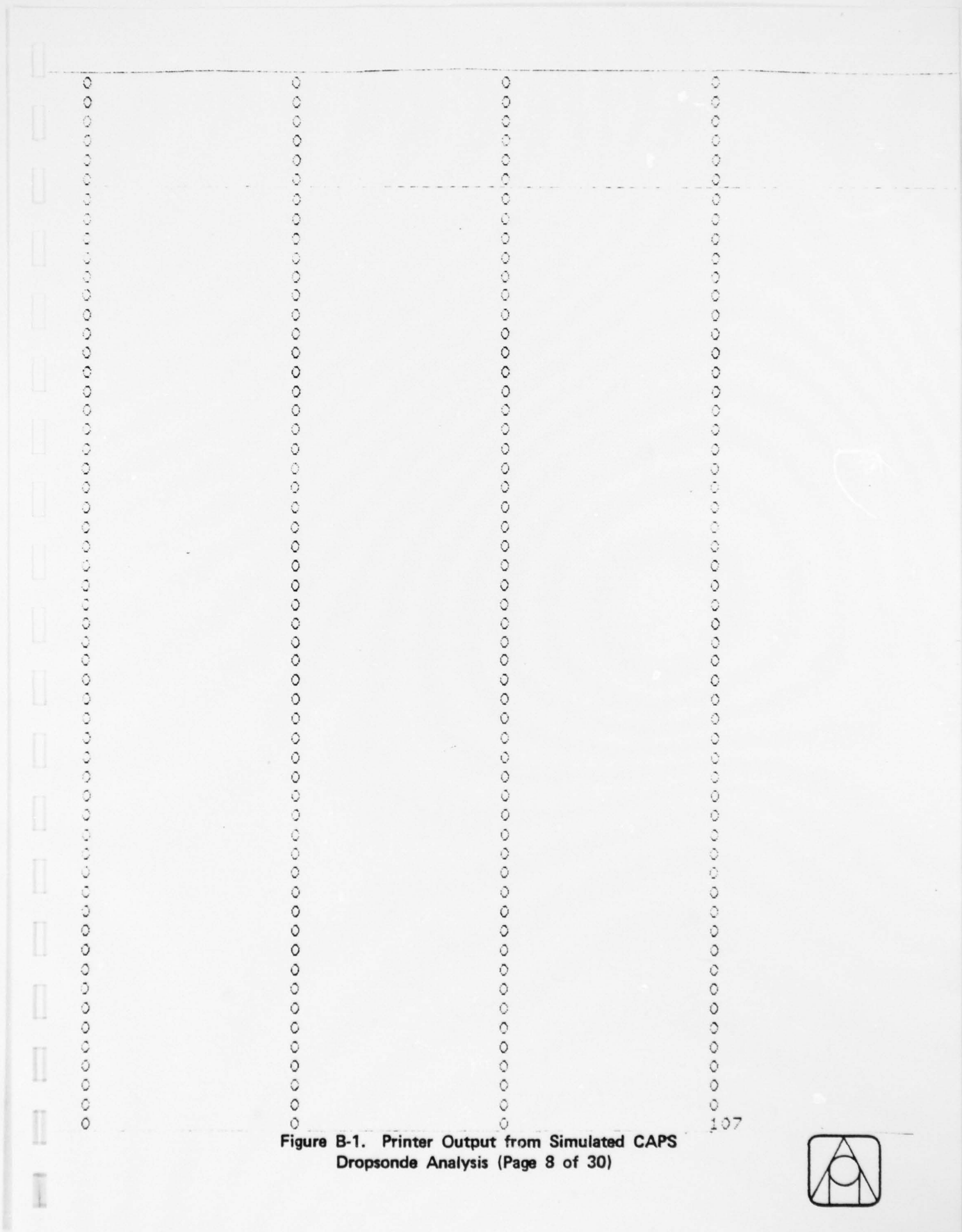

Figure B-1. Printer Output from Simulated CAPS  
Dropsonde Analysis (Page 8 of 30)

107







Figure B-1. Printer Output from Simulated CAPS  
Dropsonde Analysis (Page 10 of 30)







**Figure B-1. Printer Output from Simulated CAPS  
Dropsonde Analysis (Page 12 of 30)**



OPR-ENTERED EBT OF SLRF PRES= 1011.1 HB  
T4 = 15 DEG C  
TIME TAG, TEMP, PRES, HUM= 15 10.2618104889 785.651772161 40.6701131424  
PRES COEF L(3,6) ARE AS FOLLOWS:

33.0042e	3.770e2	-0.15574	3.5323e
-0.01776997	3.04286E-5		
333.173	-66.71563	2.75357	0.8213251
0.00108737	-1.513306E-6		
0.7770e	-0.17717	0.010342	6.01033
-0.031607	4.571193E-5		

TIME TAG, TEMP, PRES, HUM= 2830 15.8974650984 1009.96545438 64.2107582199  
PRES COEF L(3,6) ARE AS FOLLOWS:

33.0042e	3.770e2	-0.15574	3.5323e
-0.01776997	3.04286E-5		
333.173	-66.71563	2.75357	0.8213251
0.00108737	-1.513306E-6		
0.7770e	-0.17717	0.010342	6.01033
-0.031607	4.571193E-5		

Figure B-1. Printer Output from Simulated CAPS  
Dropsonde Analysis (Page 13 of 30)





107

Figure B-1. Printer Output from Simulated CAPS  
Dropsonde Analysis (Page 15 of 30)







---

--	--	--	--

---

107

**Figure B-1. Printer Output from Simulated CAPS  
Dropsonde Analysis (Page 17 of 30)**







Figure B-1. Printer Output from Simulated CAPS  
Dropsonde Analysis (Page 19 of 30)







Figure B-1. Printer Output from Simulated CAPS  
Drosopside Analysis (Page 21 of 30)











108

**Figure B-1. Printer Output from Simulated CAPS  
Dropsonde Analysis (Page 25 of 30)**



DETAILED LIST OF ATMOSPHERIC PARAMETERS

ALT(FT)	ALT(M)	PR(MB)	T(DEG-C)	RH(%)	N-UNITS	H-UNITS	G/M3	D-PT-DEP	N/H	N/H-CLASS
7717.	2352.	767.7	10.20	42.2	234.6	605.	4.06	12.3	-0.0262	NORML-
7078.	2157.	785.8	11.59	40.7	239.7	579.	4.28	12.9	0.0000	SUBFR+
7077.	2157.	785.8	11.59	40.7	239.7	579.	4.28	12.9	-0.0034	NORML-
7072.	2155.	786.0	11.57	40.7	239.7	579.	4.27	12.9	-0.0037	NORML-
7071.	2155.	786.0	11.57	40.7	239.7	579.	4.27	12.9	0.0000	SUBFR+
7070.	2155.	786.0	11.57	40.7	239.7	579.	4.27	12.9	-0.0186	NORML-
7047.	2148.	786.7	11.51	40.6	239.9	578.	4.25	12.9	-0.0356	NORML-
7013.	2138.	787.7	11.65	40.6	240.2	577.	4.29	12.9	-0.0226	NORML-
6989.	2130.	788.4	11.74	40.5	240.4	576.	4.30	13.0	-0.0241	NORML-
7044.	2147.	786.8	11.84	40.4	240.0	578.	4.32	13.0	-0.0260	NORML-
7039.	2145.	786.9	11.85	40.4	240.0	578.	4.32	13.0	-0.0260	NORML-
7030.	2143.	787.2	11.86	40.4	240.1	578.	4.32	13.0	-0.0260	NORML-
7024.	2141.	787.4	11.86	40.4	240.2	577.	4.32	13.0	-0.0260	NORML-
7019.	2139.	787.5	11.87	40.4	240.2	577.	4.32	13.0	-0.0253	NORML-
7013.	2138.	787.7	11.87	40.4	240.2	577.	4.32	13.0	-0.0257	NORML-
6912.	2107.	790.6	11.87	40.4	241.0	573.	4.32	13.0	-0.0164	NORML-
6912.	2107.	790.6	11.88	40.4	241.0	573.	4.32	13.0	-0.0216	NORML-
6937.	2114.	789.9	11.99	40.3	240.9	574.	4.34	13.1	-0.0058	NORML-
6908.	2106.	790.7	11.89	40.2	240.9	573.	4.30	13.1	-0.0312	NORML-
6907.	2105.	790.7	11.89	40.1	240.9	572.	4.30	13.1	-0.0301	NORML-
6906.	2105.	790.7	11.90	40.1	240.9	572.	4.30	13.1	-0.0440	NORML-
6891.	2100.	791.2	12.02	40.1	241.2	572.	4.33	13.1	-0.0039	NORML-
6875.	2095.	791.6	11.90	40.1	241.2	571.	4.30	13.1	-0.0242	NORML-
6872.	2095.	791.7	11.90	40.1	241.2	571.	4.30	13.1	-0.0229	NORML-

Figure B-1. Printer Output from Simulated CAPS  
Dropsonde Analysis (Page 26 of 30)



6870.	2094.	791.8	11.90	40.1	241.2	571.	4.30	13.1	-0.0230	NORML-
6835.	2083.	792.8	11.95	40.0	241.4	570.	4.30	13.2	-0.0276	NORML-
6615.	2016.	799.2	12.42	39.6	243.3	561.	4.39	13.3	0.0720	SUBFR+
6610.	2015.	799.3	12.42	39.4	243.2	560.	4.37	13.4	0.0977	SUBFR+
6606.	2013.	799.4	12.43	39.1	243.1	560.	4.34	13.5	-0.0288	NORML-
6540.	1993.	801.4	12.50	39.1	243.6	558.	4.36	13.5	-0.0638	NORML-
6533.	1991.	801.6	12.45	39.3	243.8	557.	4.36	13.4	-0.0308	NORML-
6531.	1991.	801.6	12.45	39.3	243.8	557.	4.37	13.4	-0.0319	NORML-
6528.	1990.	801.7	12.46	39.3	243.8	557.	4.37	13.4	-0.0331	NORML-
6493.	1979.	802.7	12.56	39.3	244.2	556.	4.39	13.5	-0.1145	SPRF--
6495.	1980.	802.7	12.48	39.3	244.1	556.	4.37	13.4	-0.0887	SPRF--
6492.	1979.	802.8	12.58	39.3	244.2	556.	4.40	13.5	-0.0289	NORML-
5838.	1780.	822.0	13.67	38.8	249.9	530.	4.65	13.7	-0.0247	NORML-
5897.	1797.	820.3	13.67	38.9	249.5	533.	4.65	13.7	-0.0347	NORML-
5894.	1797.	820.4	13.67	38.9	249.5	532.	4.65	13.7	-0.0341	NORML-
5889.	1795.	820.5	13.68	38.9	249.6	532.	4.66	13.7	-0.0347	NORML-
5886.	1794.	820.6	13.68	38.9	249.6	532.	4.66	13.7	-0.0347	NORML-
5883.	1793.	820.7	13.68	38.9	249.7	532.	4.66	13.7	-0.0323	NORML-
5832.	1778.	822.2	13.71	39.0	250.2	530.	4.68	13.7	-0.0264	NORML-
5632.	1717.	828.2	14.35	38.2	251.8	522.	4.77	14.0	-0.2083	TRP---
5632.	1717.	828.2	14.36	38.3	251.8	522.	4.78	14.0	-0.2031	TRP---
5631.	1716.	828.2	14.37	38.3	251.8	522.	4.79	14.0	-0.1386	SPRF--
5622.	1714.	828.5	14.48	38.6	252.2	522.	4.86	13.9	-0.0184	NORML-
5502.	1677.	832.1	14.55	38.1	252.9	517.	4.82	14.1	-0.0335	NORML-
5499.	1676.	832.2	14.56	38.1	252.9	517.	4.82	14.1	-0.0335	NORML-
5496.	1675.	832.3	14.57	38.1	253.0	517.	4.82	14.1	-0.0335	NORML-

Figure B-1. Printer Output from Simulated CAPS  
Dropsnde Analysis (Page 27 of 30)



5451.	1661.	833.6	14.68	38.1	253.4	515.	4.85	14.1a	-0.0338	NORML-
4460.	1359.	863.9	15.61	39.6	263.6	478.	5.34	13.7	-0.0406	NORML-
3859.	1175.	882.8	15.89	42.2	271.1	456.	5.79	12.8	-0.0692	NORML-
3548.	1112.	889.5	15.44	46.2	275.5	451.	6.16	11.5	-0.1145	SPRF--
3546.	1111.	889.6	15.43	46.3	275.6	451.	6.17	11.4	-0.1131	SPRF--
3543.	1110.	889.6	15.42	46.4	275.7	451.	6.18	11.4	-0.1132	TRF---
3541.	1110.	889.7	15.33	47.0	276.1	451.	6.23	11.2	-0.0644	NORML-
3104.	1099.	890.9	15.42	47.4	275.8	450.	6.32	11.1	0.0088	SUBFR+
3636.	1106.	889.9	14.97	48.6	275.9	451.	6.30	10.7	-0.0647	NORML-
3629.	1106.	890.1	14.98	48.7	277.0	451.	6.31	10.7	-0.0646	NORML-
3623.	1104.	890.3	14.98	48.8	277.1	451.	6.33	10.7	-0.0488	NORML-
3527.	1075.	893.3	15.04	49.4	279.5	448.	6.43	10.5	-0.0594	NORML-
1352.	1022.	899.1	13.96	53.7	281.7	443.	6.54	9.2	0.0307	SUBFR+
3217.	981.	903.4	13.36	51.3	280.5	435.	6.03	9.8	0.0070	SUBFR+
7064.	934.	908.5	13.53	48.6	280.1	427.	5.77	10.6	-0.0461	NORML-
2935.	895.	912.7	13.07	50.3	282.0	423.	5.81	10.1	-0.1143	SPRF--
2604.	855.	917.1	12.43	56.6	286.5	421.	6.27	8.4	-0.2046	TRF---
2736.	834.	919.4	11.68	63.8	290.8	422.	6.75	6.6	-0.3810	TRF---
2663.	812.	921.8	11.72	75.9	299.2	427.	8.05	4.1	0.2236	SUBFR+
2693.	821.	920.8	11.47	80.3	301.2	430.	8.39	3.3	-0.0915	SPRF--
2604.	794.	923.8	11.64	82.4	303.6	429.	8.69	2.9	0.3418	SUBFR+
2604.	794.	923.8	11.62	82.5	303.7	429.	8.69	2.9	0.3418	SUBFR+
2604.	794.	923.8	11.60	82.6	303.7	429.	8.70	2.8	-0.0827	SPRF--
2608.	795.	923.8	11.36	83.4	303.6	429.	8.64	2.7	-0.0994	SPRF--
2381.	726.	931.3	11.66	89.9	310.5	425.	9.50	1.6	-0.0207	NORML-
1980.	604.	945.0	11.74	87.7	313.0	408.	9.31	2.0	-0.0093	NORML-

Figure B-1. Printer Output from Simulated CAPS  
Dropsonde Analysis (Page 28 of 30)



1776.	541.	952.1	12.22	83.9	313.6	399.	9.18	2.6	-0.0261	NORML-
1774.	541.	952.1	12.23	83.9	313.6	399.	9.18	2.6	-0.0265	NORML-
1766.	538.	952.4	12.24	83.8	313.7	398.	9.18	2.6	-0.0331	NORML-
1729.	527.	953.7	12.31	83.6	314.0	397.	9.19	2.7	-0.0306	NORML-
1593.	486.	958.4	12.63	82.4	315.3	392.	9.25	2.9	0.5965	SUBFR+
1593.	485.	958.4	12.59	82.4	315.2	392.	9.22	2.9	0.0972	SUBFR+
1592.	485.	958.4	12.60	82.3	315.1	392.	9.22	2.9	0.0958	SUBFR+
1590.	485.	958.5	12.61	82.2	315.1	391.	9.21	2.9	0.0466	SUBFR+
1579.	481.	958.9	12.67	81.5	314.9	391.	9.17	3.1	-0.0249	NORML-
1162.	354.	973.5	13.72	76.9	318.1	374.	9.24	4.0	-0.0165	NORML-
1008.	307.	978.9	13.93	75.3	318.9	367.	9.16	4.3	-0.0334	NORML-
1000.	305.	979.2	13.94	75.3	318.9	367.	9.16	4.3	-0.0333	NORML-
991.	302.	979.5	13.97	75.2	319.0	367.	9.17	4.3	-0.0336	NORML-
986.	301.	979.7	13.98	75.2	319.1	366.	9.17	4.3	-0.0334	NORML-
945.	288.	981.1	14.08	74.9	319.5	365.	9.19	4.4	-0.0329	NORML-
940.	287.	981.3	14.09	74.9	319.5	365.	9.20	4.4	-0.0336	NORML-
936.	285.	981.4	14.10	74.8	319.6	365.	9.20	4.4	-0.0179	NORML-
779.	237.	987.0	14.12	73.9	320.4	358.	9.09	4.6	0.5555	SUBFR+
784.	239.	986.8	14.53	73.9	321.3	359.	9.32	4.6	-0.0045	NORML-
650.	198.	991.6	14.77	71.7	321.5	353.	9.18	5.0	-0.0008	NORML-
431.	131.	999.4	15.82	66.2	321.5	342.	9.03	6.3	0.0147	SUBFR+
419.	131.	999.5	15.81	66.1	321.5	342.	9.02	6.3	0.0160	SUBFR+
425.	130.	999.6	15.80	66.1	321.5	342.	9.01	6.3	0.0043	SUBFR+
388.	118.	1001.0	15.67	65.9	321.4	340.	8.92	6.3	0.2326	SUBFR+
382.	116.	1001.2	16.00	64.4	321.0	339.	8.89	6.7	-0.0327	NORML-

Figure B-1. Printer Output from Simulated CAPS  
Dropsonde Analysis (Page 29 of 30)



375.	114.	1001.5	16.01	64.4	321.1	339.	8.89	6.7	-0.0322	NORML-
368.	112.	1001.7	16.02	64.4	321.1	339.	8.90	6.7	-0.0364	NORML-
272.	83.	1005.2	16.15	64.3	322.2	335.	8.94	6.7	-0.0794	SPRF--
249.	76.	1006.0	16.35	64.2	322.8	335.	9.04	6.8	-0.0677	NORML-
139.	42.	1010.0	16.90	64.2	325.0	332.	9.35	6.8	-0.0318	NORML-
0.	0.	1015.0	16.90	64.2	326.4	326.	9.35	6.8		

SIGNIF LEVS (T1,H10) LIST OF ATMOSPHERIC PARAMETERS

ALT(FT)	ALT(M)	PR(MB)	T(DEG-C)	RH(%)	N-UNITS	M-UNITS	G/M3	D-PT-DEP
0.	0.	1015.0	16.90	64.2	326.4	326.	9.35	6.8
1980.	504.	945.0	11.74	87.7	313.0	408.	9.31	2.0
2663.	812.	921.8	11.72	75.9	299.2	427.	8.05	4.1
3064.	934.	908.5	13.53	48.6	280.1	427.	5.77	10.6
3859.	1176.	882.8	15.89	42.2	271.1	456.	5.79	12.8
7013.	2138.	787.7	11.65	40.6	240.2	577.	4.29	12.9
7078.	2157.	765.8	11.59	40.7	239.7	579.	4.28	12.9

MANDATORY LEVELS

ALT(FT)	ALT(M)	PR(MB)	T(DEG-C)	RH(%)	N-UNITS	M-UNITS	G/M3	D-PT-DEP
0.	0.	1015.0	16.90	64.2	326.4	326.	9.35	6.8
407.	124.	1000.0	15.74	66.0	321.5	341.	8.96	6.3
4465.	1361.	850.0	15.61	39.6	263.6	478.	5.34	13.7

Figure B-1. Printer Output from Simulated CAPS  
Dropsonde Analysis (Page 30 of 30)



APPENDIX C  
ANALYSIS EXAMPLE FOR MINIREFRACTIONSONDE



APPENDIX C. ANALYSIS EXAMPLE FOR MINIREFRACTIONSONDE (MRS)

The operation of the Minirefractionsonde program was demonstrated by using the magnetic tape-reproduced output signal from the receiver in the San Diego test of 2 May 1978 using MRS #8. The CRT-displayed plots of temperature, humidity, refractivity and modified refractivity (M-units) are shown in Figures C-1 and C-2. The computer-produced printout from the run is shown in Figure C-3.

This processing run was limited to roughly the first half of the sounding's tape where data were found satisfactory for analysis. The analysis run was performed at 0925 on 25 May 1978. Approximately one minute after launch the processing was switched from the Honeywell receiver output to the Microdyne receiver output.



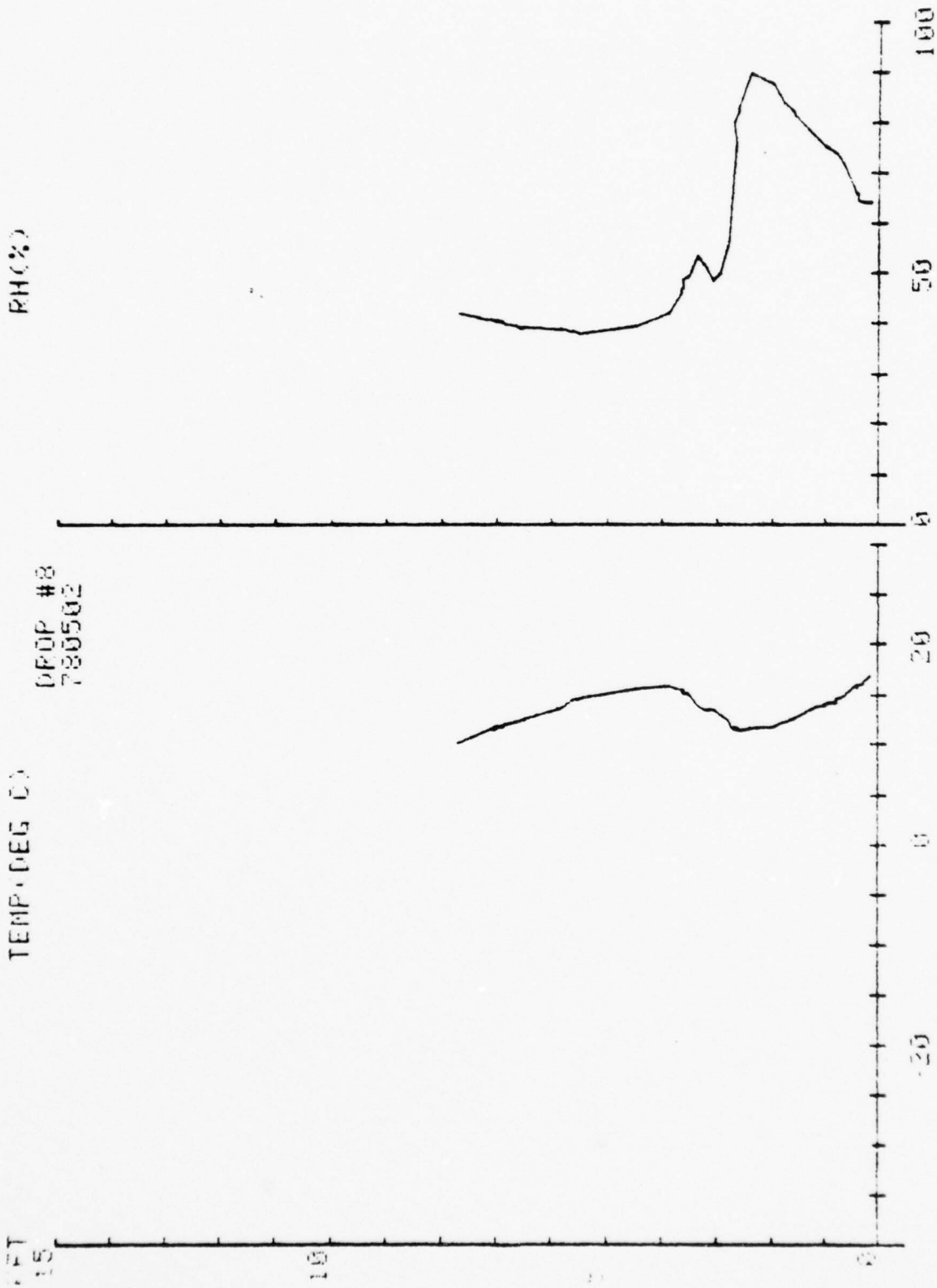

Figure C-1. Temperature and Humidity Profiles in Altitude



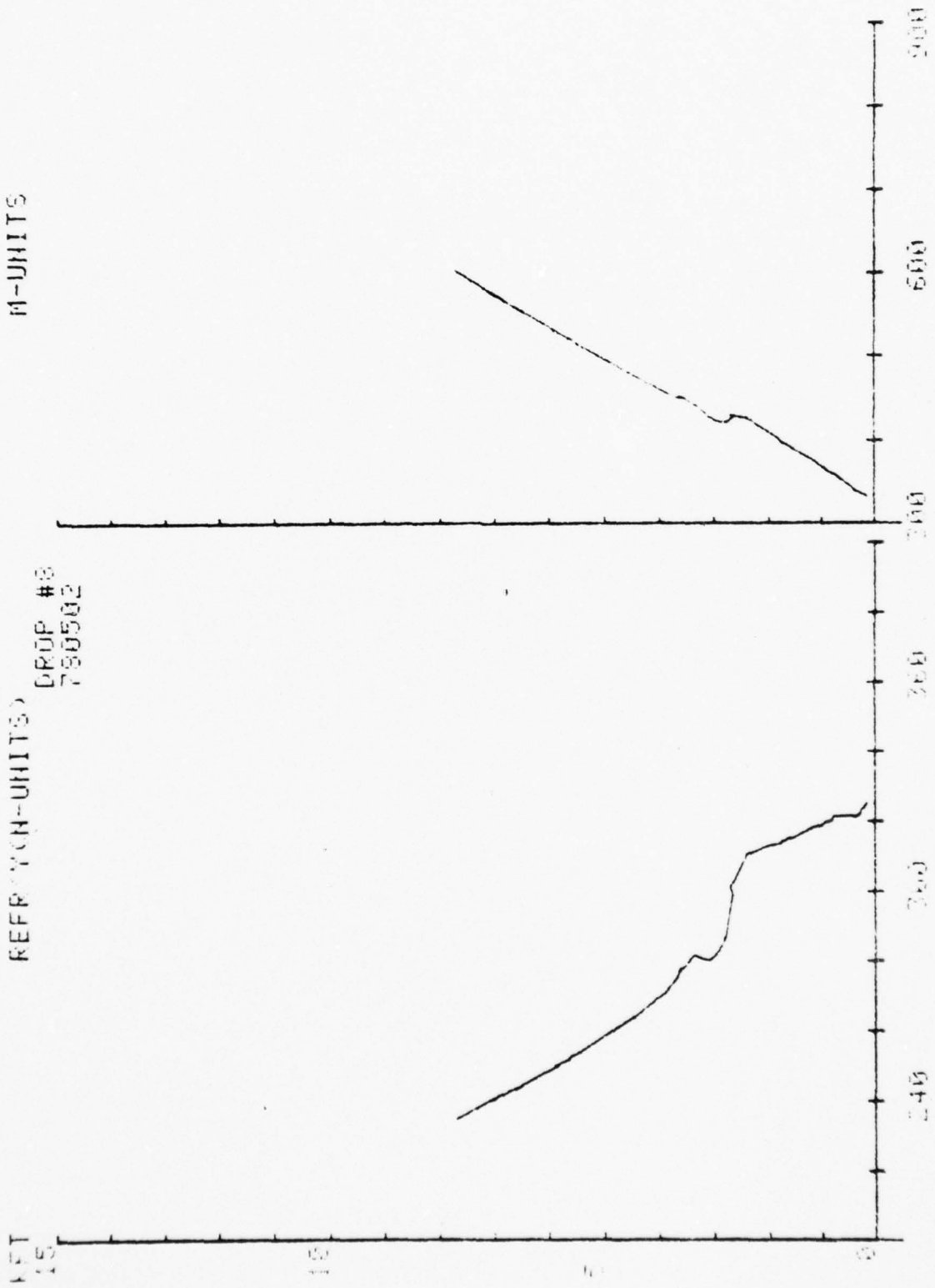

Figure C-2. Refractivity (N = units) and Modified Refractivity (M = units) Profiles in Altitude



			M=1	S.L.=1
			M=2	S.L.=2
			M=3	S.L.=3
0.54137235127	0.551967447297	0.531384045475		12.00051077
			M=1	S.L.=5.54002542785
			M=2	S.L.=6.55033100424
			M=3	S.L.=7.53065956952
0.542212072246	0.552038109674	0.529122736679		16.00050901
0.541400023317	0.550558034508	0.530253237407		20.00051015
0.54286284612	0.551990515683	0.52994250466		24.00050952
0.541931625533	0.551630287749	0.525946194887		28.00050997
0.544081242883	0.552228540482	0.525895934248		32.00050972
0.541888257098	0.551784108271	0.524346084286		36.00050873
0.542637834457	0.552487055612	0.526448579991		40.00051136
0.544590543579	0.553859701412	0.527762426864		44.000510705
0.543898549529	0.553452725636	0.528231734658		48.00051005
0.544188875609	0.554053521766	0.529804557904		52.00051021
0.542399200292	0.554588478486	0.52886042858		56.00050929
0.543122654923	0.554263312998	0.531730350523		60.0005101
0.543431266891	0.554160458515	0.532740030318		64.00050899
0.54288347609	0.553168585795	0.534829285474		68.00051121
			M=1	S.L.=81.54345126689
			M=2	S.L.=62.5541604585
			M=3	S.L.=63.5327400303
0.545507442347	0.555428670865	0.53596779034		72.00051019
0.543870597359	0.554884090637	0.534697800946		76.00050901
0.543818619108	0.554477969349	0.536290454221		80.00050981
0.544468241204	0.556187867611	0.537548128396		84.00050956
0.543566021883	0.555763317996	0.53889593711		88.00050991
0.545304364208	0.556536330642	0.541912766356		92.00051021
0.545488337773	0.556124675438	0.541370943919		96.0005093
0.546271192243	0.557559696191	0.543780486518		100.00051109
0.546479957058	0.556939424053	0.543665829105		104.0005089
0.545770687515	0.557098040073	0.54411372958		108.0005104
0.547419943821	0.557552541558	0.545629363432		112.00050991
0.547067629334	0.557800242886	0.545658154594		116.00050976
0.547591049843	0.558399395585	0.54743392121		120.00051019
0.548160849913	0.557997732248	0.548124924763		124.00050929
0.547982162089	0.558312233512	0.550997287105		128.00050944
0.54859309487	0.558184983249	0.553488090246		132.00051023
0.549093337581	0.559066505971	0.556158040134		136.00051029
0.549085743112	0.558980484117	0.558116762102		140.00050995
0.549084645073	0.559886223862	0.557324357294		144.00050987
0.549680231174	0.560265133611	0.556903111347		148.00050971
0.549387773256	0.559994286782	0.557526964433		152.00050987
0.549304389774	0.560189661993	0.557099543236		156.00050992
0.551374011965	0.5606468855837	0.558676207883		160.00051039
0.549870629047	0.560353357667	0.556923305664		164.00050896
0.55049154891	0.561299372868	0.556349192649		168.00051137

Figure C-3. Computer Printout from Analysis of Mini Refraction Sonde Test at San Diego on 2 May 1978 (Page 1 of 57)



M=1 S.L.=161.549670629  
M=2 S.L.=162.560353358  
M=3 S.L.=163.556925306

0.551072658591	0.561612079029	0.553921252016	172.00050854
0.549393311998	0.561074757089	0.550610900674	176.00051008
0.551105062534	0.5630800128	0.552766105447	180.00051048
0.550630830469	0.56173641942	0.550289391923	184.00050933
0.551106370378	0.563298477303	0.552759222269	188.00051095
0.55230558885	0.563205392703	0.553163486323	192.00051004
0.551574005479	0.563653330094	0.554335676353	196.00051077
0.551932433655	0.563592688718	0.556458918307	200.00050984
0.552005415458	0.563936130217	0.55699154001	204.00051014
0.552535821564	0.563936781609	0.556578981019	208.00051036
0.552166432534	0.56338806267	0.55683991098	212.00050944
0.551617692388	0.563082742526	0.554498703958	216.00050876
0.552047735996	0.563267113054	0.55501886663	220.00050912
0.551806002776	0.563497863106	0.555713306209	224.00050876
0.553346123172	0.564624606657	0.555268546167	228.00051041
0.553723202372	0.564734096171	0.554406132783	232.00050924
0.552783539207	0.565068341173	0.551737401129	236.00050942
0.553369555022	0.566356687332	0.553631728578	240.00051009
0.553493499292	0.56568796137	0.553267873953	244.00050911
0.55338309369	0.56689455839	0.554526985147	248.00051079
0.554284367442	0.56765212559	0.554403993591	252.0005107
0.554438265342	0.567701552329	0.551032048723	256.00050963
0.553796060882	0.567256568263	0.551165219461	260.00051032
0.554530284626	0.567105321705	0.549312212304	264.00050929
0.553643450539	0.566831765819	0.549529525213	268.00050925
0.554193410163	0.56771628109	0.550605235958	272.00051013
0.55414357262	0.56851446931	0.549760925882	276.00050908
0.55484549416	0.567577907245	0.550860105386	280.00050962
0.554430023441	0.568378309033	0.550739994567	284.00050938
0.555654238785	0.569766792191	0.552828925324	288.0005104
0.556141747866	0.568768052102	0.551823791117	292.00050964
0.556100463551	0.569073108653	0.551751570751	296.0005099
0.557518616292	0.569419004646	0.553387286802	300.00050977
0.557672535399	0.570047742036	0.553438078002	304.00050992
0.558413901243	0.571715179162	0.553498093922	308.00051026
0.559131861085	0.569862018882	0.554718268844	312.00050985
0.559111735065	0.572064296283	0.554963808163	316.00051085
0.560076691807	0.571229409986	0.555278698363	320.0005094
0.559291370963	0.570740865277	0.554774934137	324.00050903
0.558945165338	0.571567847418	0.55728863477	328.00051107
0.560266242132	0.572405091684	0.55704605034	332.0005097
0.559611481678	0.57314291493	0.557203227978	336.00051046
0.560720641262	0.573233854307	0.557641275439	340.00051063

Figure C-3. Computer Printout from Analysis of Mini Refraction  
Sonde Test at San Diego on 2 May 1978 (Page 2 of 57)



			M#1	S.L.=333.559611482
			M#2	S.L.=334.573142915
			M#3	S.L.=333.557203225
0.559934175912	0.573302165631	0.556279257228		344.00050963
0.55996748946	0.573683263212	0.557292524818		348.00051031
0.56022902111	0.57255256537	0.557049531114		352.0005092
0.559632500187	0.57340992978	0.557962905269		356.00050991
0.560168244995	0.573127664121	0.559122939821		360.00050925
0.559207421061	0.573511686649	0.557287158734		364.00050901
0.560021548567	0.574013602378	0.560235012711		368.00051053
0.561523696874	0.575234155743	0.560288227548		372.0005102
0.562008396387	0.575244141726	0.561043287326		376.00051003
0.563405596072	0.574931834056	0.561968000864		380.00051052
0.563209162621	0.576431429282	0.560899729317		384.00050951
0.56255657283	0.576472916431	0.561949659932		388.00051004
0.563305126721	0.575899666686	0.562215189418		392.00050936
0.5633621549421	0.577198306121	0.562774507474		396.00051013
0.565444795077	0.577213819771	0.564428031493		400.00051058
0.565233040745	0.577345597303	0.563704366886		404.00051004
0.565447361933	0.57758601177	0.564532870683		408.00051067
0.565867236495	0.576885229214	0.563315062402		412.00050939
0.564340944618	0.577905948006	0.564120815389		416.00050962
0.5653387007743	0.576750138743	0.564665688312		420.00050884
0.565557298194	0.576323368224	0.566210911797		424.00051064
0.566739584336	0.578235687488	0.565666430547		428.00050968
0.566925390035	0.579263096902	0.565651694159		432.00051002
0.566838562531	0.579110510599	0.566181210227		436.00051006
0.567528032454	0.57957500937	0.566879158078		440.00051056
0.567835283298	0.57986442837	0.566378371379		444.00050912
0.5668717549	0.58033529472	0.567960738221		448.00051068
0.567999956141	0.580063687024	0.567122088832		452.00050942
0.56641315332	0.58134380235	0.568002784134		456.00051085
0.568618994644	0.58189596245	0.568638317325		460.00051068
0.567583793529	0.582231701692	0.567414923484		464.00051024
0.567638949137	0.582617425928	0.568566026547		468.0005111
0.56817069231	0.58123212597	0.566064668927		472.00050916
0.566049535113	0.58146558122	0.565770036802		476.00050937
0.566948050494	0.582476051289	0.567336013605		480.00051093
0.568092099506	0.584279680581	0.567550674939		484.00051066
0.567075203047	0.583936721458	0.567125000939		488.00051033
0.568633680983	0.583684210526	0.566779646533		492.00050995
0.568654727822	0.584053920951	0.567704393946		496.00050996
0.569430335355	0.582874285714	0.568767772909		500.00051007
0.569050940474	0.583467801925	0.568657765459		504.00050961
0.569559099799	0.583757681173	0.570437885422		508.00051067
0.570622466063	0.584009661283	0.569481828513		512.0005097
0.569461819198	0.584585324486	0.570454067703		516.00051053
0.570085634878	0.585716907127	0.571147440045		520.00051089
0.571040452116	0.586220752681	0.570714641286		524.00051033
0.570627126249	0.585057431696	0.570874082254		528.00050939
0.571341683667	0.584717284092	0.571177797276		532.00051024
0.571009626482	0.586333747184	0.572533282637		536.00050984

Figure C-3. Computer Printout from Analysis of Mini Refraction Sonde Test at San Diego on 2 May 1978 (Page 3 of 57)



0.571223260294	0.585694408495	0.572988827987	540.00050945
0.571698687176	0.58632634038	0.57308662901	544.00050955
0.57255301767	0.585880230714	0.574634731963	548.00051028
0.573942554758	0.587371825118	0.57535478222	552.00051049
0.57539141556	0.588462469594	0.576008580868	556.00051041
0.575744755557	0.586920748898	0.575327242578	560.00050967
0.575062609969	0.587373999194	0.575314189761	564.00051007
0.574785002384	0.588125367694	0.576038362066	568.00050961
0.574596502069	0.587767520658	0.576667460265	572.00051039
0.576435944538	0.590094099695	0.577454953465	576.00051052
0.576640811785	0.589784139444	0.578449129475	580.00051134
0.577115285002	0.590674084527	0.576377419602	584.00051003
0.575884796203	0.59077496326	0.578643286153	588.00051103
0.577037414841	0.59026146136	0.576802459848	592.00050893
0.575033317158	0.589613741854	0.576980780577	596.00050984
0.577943829197	0.590367094616	0.578629857737	600.00051009
0.577604458549	0.590964350635	0.579357068667	604.00051073
0.579520700018	0.591846194852	0.580532226986	608.00051069
0.580080900035	0.591710625471	0.578945881218	612.00051007
0.580076194445	0.592359054752	0.580346071537	616.00051015
0.580698958573	0.591164062862	0.581254489169	620.00051001
0.580846252884	0.592135523137	0.580539993608	624.0005096
0.580753525473	0.592572390182	0.582539267574	628.00051158
0.581640090029	0.593016500116	0.579929691659	632.00050912
0.578836512236	0.591979999791	0.580324575343	636.00050901
0.579396872299	0.591642560903	0.581756414589	640.00050955
0.580527246466	0.592927144003	0.581186363689	644.00051051
0.582059350423	0.594366197183	0.582623134179	648.00051073
0.582529593773	0.594227721849	0.581207305766	652.00050925
0.581871545859	0.59424834468	0.581462692241	656.00051029
0.582192837614	0.593797682138	0.581778689476	660.00050932
0.582140450384	0.594267263487	0.581371892457	664.0005103
0.583507606924	0.596569480284	0.583962539655	668.00051154
0.584944373172	0.595158714431	0.582964720809	672.00050955
0.582943645688	0.596174071564	0.582992626048	676.00051079
0.584353687103	0.596297377796	0.58407814379	680.00051025
0.583203770105	0.59610799439	0.583158933191	684.00050981
0.584804059569	0.596912280702	0.584805942266	688.00051091
0.584338627465	0.596926299039	0.58300360723	692.00050944
0.582966423919	0.596592902758	0.583579163959	696.00051071
0.585512664054	0.598591054014	0.584548640561	700.00051063
0.584316936038	0.597762024723	0.583017962628	704.00050969
0.584503128448	0.598563555347	0.585292571616	708.00051122
0.585239115345	0.599290280955	0.585127414683	712.00051051
0.584317003912	0.598304329471	0.584730025994	716.00050991
0.584678300571	0.598848605063	0.585495753111	720.00051054
0.585513265118	0.599438789288	0.585137225288	724.00051058
0.585780012108	0.600021154818	0.585337391503	728.0005105
0.586347553002	0.599682595662	0.584748585688	732.00050974
0.584357306274	0.598783337835	0.583930698097	736.00051
0.586405490296	0.599576968273	0.585328929999	740.00051048
0.585398170839	0.600360110151	0.585127016319	744.00050982

Figure C-3. Computer Printout from Analysis of Mini Refraction  
Sonde Test at San Diego on 2 May 1978 (Page 4 of 57)



0.58632105594	0.60000940601	0.586221942569	748.00051082
0.587263123405	0.601747749022	0.586417735403	752.00051037
0.585784484778	0.601343943413	0.584999601865	756.00050981
0.586900335487	0.600790816627	0.585090449069	760.00050972
0.58614472505	0.601228550523	0.585168783199	764.00050917
0.586861723979	0.599761072467	0.585137340532	768.00050998
0.586594557795	0.602834993678	0.585149272346	772.00051027
0.587537588321	0.601390019706	0.584665807981	776.00050905
0.588043454925	0.601671506481	0.585099060797	780.00051035
0.588521658965	0.603000993237	0.585032766485	784.00050959
0.588805876728	0.60312788141	0.585653489056	788.00051083
0.59082364812	0.604420903119	0.585986554007	792.00051046
0.589755140529	0.605546136792	0.58741492462	796.00051106
0.590678142563	0.604612489348	0.586864971443	800.00051059
0.590892783218	0.605660377358	0.585994653522	804.00051019
0.589451635466	0.604953137976	0.585964621158	808.00050964
0.591417067446	0.604667718703	0.584703467123	812.0005096
		M=1	S.L.=805.589451635
		M=2	S.L.=806.604953136
		M=3	S.L.=807.585964621
0.59071319517	0.606452533226	0.586247694094	816.00051072
0.592811609889	0.605219464178	0.585380758012	820.00050991
0.592253751882	0.606806102187	0.586490527577	824.00051075
0.592671590689	0.606469435038	0.586640493453	828.00051012
0.592599262235	0.60668799277	0.585764475713	832.00051022
0.59176283156	0.607289497173	0.585484578161	836.00051033
0.591268832288	0.606067805469	0.587293640176	840.00051007
0.591999724044	0.607332150216	0.585587450819	844.00050975
0.590564226341	0.607283640391	0.586007607365	848.00051011
0.591618241457	0.607049328635	0.585130193119	852.00050983
0.59155105328	0.608775824412	0.585841338972	856.00051032
0.592185708513	0.608540204269	0.58759850478	860.00051092
0.593242380851	0.609429978888	0.586745829021	864.00051096
0.593664354833	0.610868240943	0.586619499891	868.00051189
0.594047412596	0.609145686672	0.58603933552	872.00050916
0.592051765836	0.610631650767	0.587369876998	876.00051112
0.594571239042	0.61101006354	0.587921045769	880.00051011
0.592585279208	0.609729561703	0.587145509652	884.00050987
0.593691451263	0.611073202849	0.588014187202	888.00051105
0.595137126577	0.611435756197	0.588203437138	892.00051017
0.594282588214	0.612224569152	0.587373053964	896.00051009
0.595263098008	0.61169179872	0.589079834672	900.00051053
0.59463301573	0.61142274961	0.587009583226	904.00050969
0.595225179446	0.612115363868	0.589264921656	908.0005116
0.597141105353	0.613073377979	0.588115842622	912.00051005
0.595303850034	0.612074448298	0.587436230492	916.00051007
0.597233928251	0.612763402774	0.589095714096	920.00051061
0.596506666982	0.61258083127	0.586772267492	924.0005087
0.59522821447	0.612485425456	0.58815710936	928.00051039
0.597513083291	0.614154234841	0.590272398917	932.00051058
0.595998530868	0.614085607791	0.589907266411	936.00051089
0.59740461002	0.614926756461	0.590420798776	940.00051086

Figure C-3. Computer Printout from Analysis of Mini Refraction  
Sonde Test at San Diego on 2 May 1978 (Page 5 of 57)



0.59768601567	0.614753703481	0.589775749702	944.00051
0.597581836599	0.614409943873	0.589551291618	948.00051024
0.598630878567	0.61444999699	0.589761226	952.0005103
0.597854358621	0.615488982959	0.588822167438	956.00051039
0.599190537031	0.61513570189	0.589319736419	960.00051044
0.598750484119	0.61655519606	0.588461456161	964.00051097
0.599140155862	0.61610310622	0.587046051173	968.00051011
0.599104441829	0.616530461989	0.586852923622	972.00051137
0.599459907322	0.617359516616	0.586001611927	976.00051036
0.598600753802	0.617443701725	0.586525001726	980.00051125
0.599037256453	0.617432434065	0.586619712446	984.00051086
0.598878521711	0.618387116304	0.585826804034	988.00051053
0.599000082792	0.617257814768	0.585203287575	992.00050997
0.598499786077	0.617121531054	0.584444482689	996.00051028
0.599570722989	0.618047487656	0.586492987807	1000.00051113
0.599932486895	0.618945137052	0.584774646518	1004.00051034
0.59869470948	0.618470658116	0.583657510631	1008.00051005
0.599890671074	0.619217427164	0.584153945302	1012.00051099
0.599269539247	0.618912790416	0.582586227266	1016.00050982
0.599828256834	0.618318482148	0.583020942026	1020.00051022
0.59970490084	0.619532996404	0.582007174321	1024.00050966
0.598531002805	0.620735179597	0.582616069274	1028.00051061
0.600189249866	0.6197203612	0.582126738301	1032.00051059
0.599464576263	0.620973627871	0.582640859157	1036.00051039
0.600275259812	0.620195463496	0.582648027399	1040.00051003
0.600420935627	0.620211665937	0.581942462923	1044.00050966
0.600233562136	0.621385630142	0.583281978013	1048.00051155
0.601659349722	0.621368852758	0.582189162881	1052.00050962
0.600132424086	0.622744365492	0.581716468055	1056.00051051
0.601529273721	0.622512923047	0.583104966332	1060.00051071
0.602486432294	0.622964119707	0.582830126537	1064.00051054
0.601023750357	0.622281150939	0.583232385126	1068.00051025
0.601443040544	0.622277801501	0.581782711986	1072.00050985
0.600659795871	0.622916564837	0.581014698569	1076.00050969
0.600828161199	0.623767095662	0.583396072024	1080.00051103
0.602335563392	0.623836627012	0.583191526436	1084.00051049
0.602113548549	0.624957179211	0.583754127513	1088.00051114
0.602417101262	0.623248598268	0.582878808029	1092.00050928
0.60069690203	0.623409513556	0.581619731172	1096.00050982
0.601322768129	0.625453098212	0.584939074157	1100.00051167
0.603263787593	0.625520399667	0.583146737008	1104.00051003
0.602106612495	0.626049801994	0.584666488395	1108.00051122
0.603922068587	0.626872532915	0.586436918694	1112.00051151
0.601860031065	0.625853299835	0.583968531894	1116.00050982
0.602743411425	0.626250291479	0.585129978409	1120.00051073
0.602643011117	0.626581657073	0.585374599296	1124.00051036
0.602183582444	0.627128012361	0.585529037135	1128.00051078
0.603154825679	0.627379416283	0.58527314625	1132.00051028
0.602464535437	0.627083307708	0.584320397646	1136.00050937
0.60259237539	0.626154280662	0.586072119463	1140.00051046
0.60412498734	0.627981832057	0.585669099397	1144.00050991
0.603132944409	0.628367065544	0.586769928627	1148.00051091

Figure C-3. Computer Printout from Analysis of Mini Refraction  
Sonde Test at San Diego on 2 May 1978 (Page 6 of 57)



0.605123131145	0.627900681645	0.585495352513	1152.00050973
0.604185176349	0.629497600868	0.585709535005	1156.00051095
0.603582068572	0.625963876804	0.58631933232	1160.00050972
0.604893717101	0.629284930121	0.586796938043	1164.00051059
0.605493817436	0.630261646931	0.587392389256	1168.00051027
0.605217579192	0.628820476149	0.586538902998	1172.00050979
0.605196125302	0.630500580634	0.587280914114	1176.00051094
0.606359756063	0.630850116483	0.588536099384	1180.00051134
0.606509192285	0.629187842305	0.586278528429	1184.0005088
0.605054900996	0.630379652882	0.586988806351	1188.00051036
0.605840480955	0.630027422303	0.58796312766	1192.00050973
0.606092589671	0.63059267508	0.586349833318	1196.00050956
0.606293619497	0.631362303848	0.589102603605	1200.00051111
0.607115244509	0.63193482134	0.588833471417	1204.0005104
0.606424500228	0.632087620887	0.587801974124	1208.00051051
0.607218488005	0.632582096768	0.589440454208	1212.00051006
0.605859335516	0.632321592346	0.588456615271	1216.00051033
0.607230337653	0.633353584447	0.590521231425	1220.00051132
0.607724375512	0.633025873713	0.589826956933	1224.00050989
0.606143823547	0.632442691277	0.586385326647	1228.00050981
0.60720750338	0.632708889027	0.589008791663	1232.00051018
0.606141550277	0.633083743108	0.588450082146	1236.00050949
0.606310218641	0.633183923317	0.58909891029	1240.00051043
0.606383040111	0.634676788133	0.591023955742	1244.00051126
		M=1	S.L.=1237.806310224
		M=2	S.L.=1238.63316392
		M=3	S.L.=1239.56909891
0.60818463921	0.635431180334	0.590738810102	1248.00051031
0.608632890636	0.635390373401	0.591430622595	1252.00051111
0.608950737630	0.635804850129	0.5909774787	1256.00051029
0.607912514978	0.635496444627	0.590313369946	1260.00051033
0.609810854217	0.636029723404	0.591580282246	1264.00051173
0.610734969597	0.635942923255	0.591274161045	1268.00051145
0.610688072603	0.635300259778	0.591934194889	1272.00051191
0.61210663177	0.637776607436	0.590869411141	1276.00051291
AGS 127641280 FAIL REF COMP:ADD .999			
0.99083711399	0.99080018	0.991249129999	1281.9908111
		M=1	S.L.=1277.01217863
		M=2	S.L.=1278.01377091
		M=3	S.L.=1279.01449117
AGS 128041284 FAIL REF COMP:ADD .999			
0.990797359991	0.99081317	0.990426819993	1280.99081234
		M=1	S.L.=1278.99083712
		M=2	S.L.=1279.99080218
		M=3	S.L.=1280.99124913
TAGS 128741291 FAIL REF COMP:ADD .999			
0.999	0.990807939996	0.999	1292.00051113
5.11642886E-4	5.116441382E-4	5.116453904E-4	1296.00051114
		M=1	S.L.=1289.999
		M=2	S.L.=1290.99080794
		M=3	S.L.=1291.999
5.116476949E-4	5.116491472E-4	5.116503994E-4	1300.00051114

Figures C-3. Computer Printout from Analysis of Mini Refraction Sonde Test at San Diego on 2 May 1978 (Page 7 of 57)



			M=1	S.L.=1293.00051184
			M=2	S.L.=1294.00051184
			M=3	S.L.=1295.00051185
0.611954779547	0.637671027664	0.591760349371		1304.00051046
			M=1	S.L.=1297.00051185
			M=2	S.L.=1298.00051185
			M=3	S.L.=1299.00051185
0.612671351248	0.639267959073	0.592972143031		1308.00051148
			M=1	S.L.=1301.61195478
			M=2	S.L.=1302.63767103
			M=3	S.L.=1303.59176035
0.612883313603	0.638851385139	0.593104134383		1312.00051058
0.612219249732	0.637687411687	0.590605957867		1319.00050935
5.141060876E-4	5.143521328E-4	5.145115296E-4		1323.00050992
			M=1	S.L.=1316.61221925
			M=2	S.L.=1317.63768741
			M=3	S.L.=1318.59060595
5.100675985E-4	5.102100995E-4	5.103526005E-4		1330.00051049
			M=1	S.L.=1320.00051411
			M=2	S.L.=1321.00051435
			M=3	S.L.=1322.00051451
5.106701034E-4	5.108451053E-4	5.110201072E-4		1335.00051119
5.111951098E-4	5.111951105E-4	5.111951113E-4		1339.00051119
0.622323762263	0.64022141956	5.103325964E-4		1343.00051004
			M=1	S.L.=1336.00051112
			M=2	S.L.=1337.00051112
			M=3	S.L.=1338.00051112
0.612531975006	0.637804826036	5.11944275E-4		1347.00050944
			M=1	S.L.=1340.52232576
			M=2	S.L.=1341.64022142
			M=3	S.L.=1342.00051033
TAGS 134931353 FAIL REF COMP:ADD .999				
0.99082832	0.990830079997	0.99081259		1354.9908576
			M=1	S.L.=1344.61253198
			M=2	S.L.=1345.63780483
			M=3	S.L.=1346.00051194
TAGS 135341357 FAIL REF COMP:ADD .999				
0.99065402	0.990747489999	0.99086047		1358.99103081
			M=1	S.L.=1351.99082832
			M=2	S.L.=1352.99083008
			M=3	S.L.=1353.99081259
TAGS 135741361 FAIL REF COMP:ADD .999				
0.999	0.999	0.999		1362.00050995
5.107232232E-4	5.10975976E-4	5.112287287E-4		1366.00051097
			M=1	S.L.=1359.999
			M=2	S.L.=1360.999
			M=3	S.L.=1361.999
5.112837838E-4	5.110860861E-4	5.108883884E-4		1370.00051016
			M=1	S.L.=1363.00051072
			M=2	S.L.=1364.00051098
			M=3	S.L.=1365.00051123
0.613943389791	0.641789543815	5.133540038E-4		1376.00051092

Figure C-3. Computer Printout from Analysis of Mini Refraction Sonde Test at San Diego on 2 May 1978 (Page 8 of 57)



			M=1	S.L.=1367.00051128
			M=2	S.L.=1368.00051109
			M=3	S.L.=1369.00051089
0.60455145278	5.157242258E-4	5.157529826E-4		1380.00051104
			M=1	S.L.=1373.61394339
			M=2	S.L.=1374.64178954
			M=3	S.L.=1375.00051335
0.594917353082	5.11097611E-4	5.111253613E-4		1384.00051115
			M=1	S.L.=1377.60455145
			M=2	S.L.=1378.00051572
			M=3	S.L.=1379.00051575
0.616156686448	0.641878226789	0.594700148313		1388.00051081
			M=1	S.L.=1381.59491735
			M=2	S.L.=1382.00051111
			M=3	S.L.=1383.00051113
0.614509493019	0.641660904005	0.593043740757		1392.00050985
			M=1	S.L.=1385.61615669
			M=2	S.L.=1386.64187823
			M=3	S.L.=1387.59470015
0.613910115662	0.641122246502	0.595044500225		1396.00051112
0.614780783333	0.62975366663	0.594085833956		1400.00050995
			M=1	S.L.=1393.61391012
			M=2	S.L.=1394.64112225
			M=3	S.L.=1395.5950445
0.613933459407	0.642070484582	0.593864213482		1404.0005103
			M=1	S.L.=1397.61478078
			M=2	S.L.=1398.62975367
			M=3	S.L.=1399.59408583
0.614144236301	0.642757300626	0.594147908693		1408.00051054
0.612898773742	0.643035327319	0.593244675653		1413.00051024
			M=1	S.L.=1405.61414424
			M=2	S.L.=1406.6427573
			M=3	S.L.=1407.59414791
0.614696356928	0.643821627142	0.594594914162		1417.00051108
0.614621295683	0.644164814874	0.594805450851		1421.00051072
0.614208769058	0.643965930064	0.595627806658		1425.00051146
0.614918186553	0.64493238642	0.594364224685		1429.0005101
0.613542663184	0.644985539165	0.595181998702		1436.00051157
5.163098678E-4	5.163158948E-4	5.162075764E-4		1440.0005116
			M=1	S.L.=1433.61354266
			M=2	S.L.=1434.64498554
			M=3	S.L.=1435.595162
5.116063644E-4	5.11612615E-4	5.116188656E-4		1444.00051162
			M=1	S.L.=1437.00051631
			M=2	S.L.=1438.00051632
			M=3	S.L.=1439.00051631
0.614715467406	0.645756970601	0.594990037144		1448.0005102
			M=1	S.L.=1441.00051161
			M=2	S.L.=1442.00051161
			M=3	S.L.=1443.00051162
0.614453953624	0.646170094356	0.595000465792		1452.00051155

Figure C-3. Computer Printout from Analysis of Mini Refraction  
Sonde Test at San Diego on 2 May 1978 (Page 9 of 57)



			M=1 - S.L.=1445.61471547
			M=2 - S.L.=1448.64575697
			M=3 - S.L.=1447.59479004
0.616131892102	0.646066634647	0.594890617211	1457.00051076
0.615401764353	0.646251787726	0.594973664931	1461.00051046
0.615304148232	0.645812638974	0.594746395704	1465.00051015
0.615115389423	0.645335397575	0.594473588125	1469.00050979
0.614496729165	0.646409747673	0.59595829193	1473.00051071
0.616533039601	0.645779042358	0.596130932746	1477.00051037
0.61483808976	0.647733899816	0.595571087903	1481.00051121
0.616218277267	0.647105392434	0.596616924724	1485.00051044
0.615283529551	0.64792737597	0.596363075334	1489.00051024
0.61559051335	0.647706954234	0.597866307777	1493.00051144
0.61720899902	0.648068748724	0.596636710134	1497.00051037
0.616883581878	0.648157311758	0.596273974249	1501.00051075
0.617770162818	0.647261657191	0.597090950227	1505.00051037
0.617564406168	5.152296715E-4	0.597288998403	1509.0005106
			M=1 S.L.=1502.61777016
			M=2 S.L.=1503.64726166
			M=3 S.L.=1504.59709095
0.617907653959	0.622222148972	0.597664103084	1513.00051082
			M=1 S.L.=1506.61756441
			M=2 S.L.=1507.00051523
			M=3 S.L.=1508.597289
0.618887695393	0.649511976483	0.598499652536	1517.00051133
			M=1 S.L.=1510.61790765
			M=2 S.L.=1511.62222215
			M=3 S.L.=1512.5976641
0.619768618655	0.651541017482	0.598945335365	1521.00051142
			M=1 S.L.=1514.6188877
			M=2 S.L.=1515.64951198
			M=3 S.L.=1516.59849965
0.619330631565	0.651374447006	0.598983768676	1525.00051129
0.61886686571	0.651544991131	0.59834855188	1529.00051073
0.618013016282	0.651441472384	0.597587673737	1533.00051017
0.618960993478	0.649988537167	0.599101784468	1537.00051117
0.619796963716	0.651890973893	0.598604168478	1541.00051063
0.619496637671	0.651589476415	0.599353851893	1545.00051084
0.619823928463	0.651338113601	0.597942426432	1549.00051058
0.618399368791	0.650958923326	0.597687472867	1553.00050972
0.618906579596	0.650951458461	0.598439967526	1557.00051036
0.617277669868	0.651582319095	0.596566770121	1561.00050964
0.618184734885	0.652092007934	0.59899960029	1565.00051151
0.619116941529	0.654009003929	0.599482190712	1569.00051102
0.618048661981	0.653791533018	0.596345487807	1573.000511
0.620343279708	0.654077987667	0.598175514767	1580.00051118
0.620339018418	0.655403588242	0.59852988923	1584.00051142
0.619633424939	0.654392116303	0.597278975651	1588.0005097
0.618050171863	0.654034449172	0.598071024714	1592.00051096
0.620631113894	0.653754591647	0.598756641459	1597.00051061
0.62191692722	0.655348831245	0.597952435302	1601.00051159
0.625767733574	0.655963566041	0.597828370427	1605.00051109

Figure C-3. Computer Printout from Analysis of Mini Refraction Sonde Test at San Diego on 2 May 1978 (Page 10 of 57)



0.621537609345	0.655552129986	0.597166337337	1609.00051047
0.621080629635	0.655319940107	0.59868258916	1613.0005112
0.621994713985	0.656688399443	0.597415613922	1617.0005102
0.621137526266	0.656185740636	0.5971699302	1621.00051093
0.622243463195	0.656518560012	0.597744226786	1625.00051123
0.622677594706	0.656815986345	0.597473677314	1629.00051071
0.622448971835	0.657971646588	0.59907771272	1633.00051137
0.622607366587	0.656992897216	0.59896376957	1637.00051007
0.621424216349	0.65638029496	0.598063985829	1641.00051005
0.6243135567	0.657500830181	0.599030455477	1645.00051166
0.624636513534	0.658839988661	0.598208521827	1649.00050997
0.621770715431	0.657369334038	0.596837038811	1656.00051007
0.623256904072	0.657601824774	0.596628002029	1660.00050966
0.623510524762	0.658698442357	0.597315023695	1664.00051071
0.624892957149	0.660294934926	0.597763275702	1668.00051107
0.624220133753	0.660764808475	0.598715775282	1672.00051186
0.624450791509	0.659463083787	0.598742158977	1676.00051102
0.623596500324	0.659998708177	0.597832071144	1680.00051079
0.624170813531	0.660717517776	0.598843207982	1684.00051134
0.624247604604	0.660670440154	0.598569121814	1688.00051114
0.623825131952	0.660605551318	0.59785330669	1692.00051083
0.623065292133	0.660606217349	0.598985814213	1696.00051089
0.622681207147	0.660308010871	0.596936209555	1700.00050955
0.623339081373	0.66057420975	0.599018266937	1704.00051109
0.623598351556	0.661320376289	0.598786771095	1708.00051106
0.622860893988	0.662587344595	0.598192971166	1712.00051114
0.572730225759	0.662973043027	0.599244735709	1719.00051196
		M=1	S.L.=1709.62288089
		M=2	S.L.=1710.66258734
		M=3	S.L.=1711.59819297
5.166520342E-4	5.165305623E-4	5.165740946E-4	1723.00051176
		M=1	S.L.=1716.57273023
		M=2	S.L.=1717.66297304
		M=3	S.L.=1718.59924474
5.11708867E-4	5.116576165E-4	5.11606366E-4	1728.00051155
		M=1	S.L.=1720.00051665
		M=2	S.L.=1721.00051653
		M=3	S.L.=1722.00051657
0.623337557982	0.662229223364	5.109326063E-4	1732.00051072
		M=1	S.L.=1725.00051171
		M=2	S.L.=1726.00051166
		M=3	S.L.=1727.00051161
0.622552062925	0.663072322747	5.111451104E-4	1736.00051128
		M=1	S.L.=1729.62333756
		M=2	S.L.=1730.66222922
		M=3	S.L.=1731.00051093
0.622887661015	0.664502839617	0.598827138281	1740.00051135
		M=1	S.L.=1733.62255206
		M=2	S.L.=1734.66307232
		M=3	S.L.=1735.00051115
0.623109226511	0.663548550433	0.59840313651	1744.00051082

Figure C-3. Computer Printout from Analysis of Mini Refraction Sonde Test at San Diego on 2 May 1978 (Page 11 of 57)



			M=1	S.L.=1737.62288786
			M=2	S.L.=1738.66450284
			M=3	S.L.=1739.59882714
0.624064170039	0.664527997712	0.598317831313		1748.00051145
0.624538993235	0.665058329323	0.599779484628		1752.00051129
0.625408163489	0.664980888739	0.600119650982		1756.00051189
0.625499786565	0.666588463296	0.599136420696		1760.00051119
0.6246165615	0.665762956249	0.599342469989		1764.0005108
0.624552411004	0.666529790188	0.600405512744		1768.00051181
0.626326094081	0.667675292154	0.600521964867		1772.00051203
0.627634793034	0.667658341815	0.601134098604		1776.00051133
0.626379890131	0.666953719289	0.600522889618		1780.00051099
0.627015090705	0.667210525629	0.600867351344		1784.00051135
0.504883372228	0.667912349244	0.600236076321		1788.00051097
			M=1	S.L.=1781.62701509
			M=2	S.L.=1782.66721053
			M=3	S.L.=1783.60086735
5.157159309E-4	0.667503788275	0.600388028497		1792.00051101
			M=1	S.L.=1785.50488337
			M=2	S.L.=1786.66791235
			M=3	S.L.=1787.60023608
0.629839217678	0.667366434644	0.600662045473		1796.00051104
			M=1	S.L.=1789.00051572
			M=2	S.L.=1790.66750379
			M=3	S.L.=1791.60038803
0.628823112826	0.668917327471	0.601208815763		1800.00051136
			M=1	S.L.=1793.62983922
			M=2	S.L.=1794.66736643
			M=3	S.L.=1795.60066205
0.630116818451	0.667619719045	0.602922801189		1804.00051138
0.63060060647	0.667195137201	0.601997801727		1808.00051115
0.629806745187	0.668905736471	0.60067513139		1812.00051055
0.629442406165	0.670272960654	0.603080528032		1816.00051293
0.631306223171	0.670431467093	0.600090421134		1820.00051043
0.629511613517	0.669584703893	0.602433566281		1824.00051145
0.631316377372	0.66996604481	0.601949075775		1828.00051061
0.631568713804	0.670188639671	0.602169463256		1832.00051187
0.633038776708	0.671067655358	0.60228516562		1836.00051077
0.631046495145	0.672302409115	0.601449872383		1840.00051117
0.63269442782	0.671128822595	0.602169720289		1844.00051108
0.631602375525	0.670446278579	0.601769852321		1848.00051012
0.631073544972	0.671264579416	0.60177820812		1852.00051086
0.633025051277	0.671297026061	0.602863128001		1856.00051123
0.632884864788	0.672548142103	0.601988689725		1860.00051068
0.633221628424	0.673843458559	0.604334869987		1864.00051243
0.63530258171	0.673689058491	0.602756189416		1868.00051151
0.634109532652	0.674918863295	0.602990748213		1872.00051164
0.634259604713	0.673999288266	0.604111033682		1876.0005111
0.633776880878	0.673764288634	0.603164583269		1880.00051096
0.633974870818	0.674448827728	0.60362139323		1884.00051141
0.63458292836	0.674729089397	0.603829709099		1888.00051098
0.633940647775	0.674461428798	0.603498072497		1892.00051091

Figure C-3. Computer Printout from Analysis of Mini Refraction  
Sonde Test at San Diego on 2 May 1978 (Page 12 of 57)



0.635508643703	0.674605688643	0.604311724551	1896.00051132
0.634736250834	0.674375462132	0.60209660852	1900.00051017
0.633938112819	0.674602859937	0.603768063403	1904.00051072
0.634890591061	0.674600972464	0.603213475986	1908.00051041
0.634539650433	0.676232436294	0.603727705872	1912.00051181
0.636186287023	0.677070526803	0.605256943017	1916.00051253
0.636740744856	0.677522641422	0.604927732805	1920.00051162
0.635775630335	0.67689628688	0.604116419375	1924.00051071
0.635141521898	0.676834677152	0.604216135435	1928.00051173
0.636517150931	0.67843410236	0.603785108487	1932.00051162
0.636500721942	0.678606932202	0.60558163818	1936.00051233
0.637190690197	0.679060730248	0.605089878693	1940.00051168
0.636611710317	0.678612663066	0.604196464632	1944.00051103
0.636867750123	0.678260061837	0.604460319767	1948.00051123
0.636309044832	0.678993572036	0.603657245889	1952.00051128
0.637344528545	0.678946879397	0.604698787138	1956.00051173
0.63733627595	0.679880806683	0.603736454564	1963.00051043
5.152811294E-4	5.154192392E-4	5.154830455E-4	1967.00051088
		M=1	S.L.=1960.63733628
		M=2	S.L.=1961.67988081
		M=3	S.L.=1962.60373645
5.109913544E-4	5.111026044E-4	5.112138544E-4	1971.00051132
		M=1	S.L.=1964.00051528
		M=2	S.L.=1965.00051542
		M=3	S.L.=1966.00051548
0.63825602899	0.679863282747	0.605353836466	1975.00051114
		M=1	S.L.=1968.00051099
		M=2	S.L.=1969.0005111
		M=3	S.L.=1970.00051121
0.638541348597	0.680566637567	0.605725878075	1979.00051216
		M=1	S.L.=1972.63825603
		M=2	S.L.=1973.67986328
		M=3	S.L.=1974.60535384
0.638722531875	0.681600225491	0.604883334762	1983.00051129
0.638235287765	0.681986543639	0.605990058714	1987.00051244
TAGS 1987&1991 FAIL REF COMP;ADD .999			
0.99080137	0.990801889999	0.99075042	1992.99084348
		M=1	S.L.=1984.63823529
		M=2	S.L.=1985.68198654
		M=3	S.L.=1986.60599006
TAGS 1991&1995 FAIL REF COMP;ADD .999			
0.99084287	0.990843169997	0.99128004	1996.99080148
		M=1	S.L.=1989.99080137
		M=2	S.L.=1990.99080189
		M=3	S.L.=1991.99075042
TAGS 1995&1999 FAIL REF COMP;ADD .999			
0.999	0.999	0.999	2000.00051102
5.116791792E-4	5.118268268E-4	5.119744745E-4	2004.00051161
		M=1	S.L.=1997.999
		M=2	S.L.=1998.999
		M=3	S.L.=1999.999
5.118468468E-4	5.115715716E-4	5.112962963E-4	2008.00051051

Figure C-3. Computer Printout from Analysis of Mini Refraction Sonde Test at San Diego on 2 May 1978 (Page 13 of 57)



			M=1	S.L.=2001.00051168
			M=2	S.L.=2002.00051183
			M=3	S.L.=2003.00051197
0.636727227345	0.682334317432	0.605677925445		2012.00051104
			M=1	S.L.=2005.00051185
			M=2	S.L.=2006.00051157
			M=3	S.L.=2007.00051113
0.637537579004	0.683005531653	0.605938582687		2016.00051131
			M=1	S.L.=2009.63672723
			M=2	S.L.=2010.68233432
			M=3	S.L.=2011.60567793
0.639220527579	0.683311283059	0.606185542174		2020.00051132
0.639799136709	0.684303421718	0.606902401881		2024.00051222
0.639893414319	0.684056867225	0.607569361277		2028.00051169
0.640024399952	0.684523012664	0.605662135685		2032.00051096
0.639640910196	0.684818725046	0.606533115978		2036.00051131
0.640502882466	0.684637832483	0.606337644269		2040.00051158
0.639976724308	0.685033776539	0.605130361917		2044.0005106
0.639489965839	0.684603115031	0.606437351548		2048.00051091
0.640574650647	0.684503550851	0.605579665164		2052.00051078
0.640175151511	0.685646452859	0.605523978931		2056.00051136
0.642057579642	0.687482366216	0.605609141141		2061.00051164
0.642710428567	0.687813571861	0.604909820596		2065.00051087
0.641920231019	0.687203563343	5.117676118E-4		2071.00051206
			M=1	S.L.=2062.64271043
			M=2	S.L.=2063.68781357
			M=3	S.L.=2064.60490982
5.150783002E-4	5.148096866E-4	5.169111563E-4		2075.00051219
			M=1	S.L.=2068.64192023
			M=2	S.L.=2069.68720356
			M=3	S.L.=2070.00051177
0.606589428038	5.122526179E-4	5.122838687E-4		2079.00051231
			M=1	S.L.=2072.00051508
			M=2	S.L.=2073.00051481
			M=3	S.L.=2074.00051691
0.643386090161	0.689298886443	0.60648147958		2083.00051174
			M=1	S.L.=2076.60658943
			M=2	S.L.=2077.00051225
			M=3	S.L.=2078.00051238
0.641725593846	0.688913949517	0.60694725904		2087.00051209
			M=1	S.L.=2080.64338609
			M=2	S.L.=2081.68929889
			M=3	S.L.=2082.60648148
0.64262436027	0.687537823357	0.604762439364		2091.00051054
0.642865675234	0.688224209684	0.605374120765		2095.00051223
0.643549698611	0.689698607109	0.606779101198		2099.0005116
0.641870264277	0.689878456178	0.604959887875		2103.0005112
0.641355754848	0.688975583191	0.604903107504		2107.00051135
0.642443062182	0.689530372935	0.605476325786		2111.00051172
0.641833463821	0.690481019165	0.604359139342		2115.00051062
0.642339848326	0.689634234834	0.605174713831		2119.00051168
0.644247468203	0.691578932185	0.605494810923		2123.00051176

Figure C-3. Computer Printout from Analysis of Mini Refraction Sonde Test at San Diego on 2 May 1978 (Page 14 of 57)



0.642671005634	0.69193066323	0.606108606096	2127.00051173
0.644073128642	0.690484552871	0.605856201305	2131.00051085
0.643863404548	0.691943190319	0.604767532261	2135.00051133
0.644042813489	0.691664749163	0.606321049067	2139.00051149
0.644390461257	0.690811429571	0.605018458839	2143.00051098
0.643785181768	0.691727441786	0.60488353829	2147.00051149
0.645719201914	0.692609132443	0.605961295091	2151.00051184
0.644920728247	0.692603925601	0.605105502939	2155.00051151
0.644180624443	0.692039085196	0.604792430965	2159.00051113
0.644720076919	0.693470974586	0.604901525897	2163.00051192
0.64528553883	0.69412929952	0.604293764271	2167.00051106
0.645317204848	0.693065275976	0.605097340277	2171.00051214
0.646913103394	0.693516243006	0.60336058339	2175.00051106
0.645788335302	0.695418465763	0.604822790515	2179.00051229
0.647076095936	0.695773019516	0.60575955118	2183.00051154
0.644797061685	0.694878630847	0.602853230928	2187.00051096
0.643743935994	0.69460662857	0.604282013665	2191.00051214
0.64556298606	0.69486162034	0.603306116121	2195.00051128
0.643839704206	0.695775504326	0.603156395878	2199.00051151
0.646100820973	0.696402588085	0.604486239696	2203.00051255
0.645705169565	0.696096223373	0.602836753146	2207.00051125
0.643270008565	0.696096839601	0.602516156684	2211.00051172
0.64495863716	0.696208303629	0.600951638125	2215.00051101
0.644014984701	0.69714179866	0.601238892383	2219.00051146
0.644701533241	0.697460418354	0.601546773052	2223.00051113
0.643965160096	0.698025816739	0.600196213254	2227.00051071
0.644538040747	0.697320874016	0.601143978821	2231.00051219
0.645257658568	0.699144435203	0.59959867778	2235.00051071
0.642890834426	0.696761924071	0.598541871739	2239.00051139
0.644809977131	0.699308529449	0.599192360791	2243.0005121
0.644763184955	0.700321649195	0.598257621205	2247.00051121
0.643673054038	0.700665667647	0.59906516127	2251.00051186
0.645372656689	0.700782933562	0.599131216813	2255.00051211
0.644410894967	0.701621407065	0.599141315114	2259.00051172
0.643692533303	0.701159962722	0.599342366666	2263.00051235
0.644573877192	0.700907964385	0.599784718312	2267.00051137
0.6446802373083	0.702758925147	0.5997044813479	2271.00051217
0.644519885266	0.702375498733	0.599777375614	2275.00051231
0.641875758963	0.702748549096	0.599127337051	2279.00051122
0.642146637398	0.7016465368189	0.5997721118513	2283.0005115
0.643973618532	0.702769124466	0.5991076197312	2287.00051124
0.643225009793	0.703533559661	0.599797453408	2291.00051147
0.642148173061	0.701268569329	0.599633924459	2295.00051015
0.641232513532	0.701455940984	0.599730956706	2299.00051123
0.642809553486	0.703691980835	0.598064645302	2303.00051191
0.643523110034	0.703803299803	0.596801567779	2307.00051142
0.642213006699	0.703151003991	0.596838030619	2311.00051106
0.642796976598	0.704967277501	0.598472002637	2315.00051122
0.643218428878	0.70575370899	0.5997457126095	2319.00051079
0.643336725557	0.705523377411	0.598925489732	2323.00051236
0.644755881147	0.706477230331	0.598997659851	2327.00051247
0.644150990797	0.707881468399	0.600085490311	2331.00051233

Figure C-3. Computer Printout from Analysis of Mini Refraction  
Sonde Test at San Diego on 2 May 1978 (Page 15 of 57)



0.643252702868	0.706975325983	0.600632242706	2335.00051195
0.643436019641	0.706538557168	0.598036286816	2339.00051092
0.642065293149	0.706425633026	0.598403753838	2343.00051173
0.642973830606	0.707498894711	0.599004502639	2347.00051137
0.641500726247	0.706607222939	0.597765568059	2351.00051102
0.641513452805	0.706493503202	0.599311093291	2355.00051117
0.64305829491	0.706533459713	0.59731311949	2359.00051088
0.64162219336	0.706734691875	0.597264234674	2363.00051144
0.643790738933	0.707737314775	0.59898679763	2367.00051175
0.642794317012	0.708366789533	0.597812992532	2371.00051133
0.64251798602	0.70944306246	0.598604883865	2375.00051207
0.642763887322	0.71014271397	0.596013218914	2379.00051197
0.643902237661	0.710911362914	0.597585376077	2383.00051224
0.643789574704	0.711211322443	0.598646800877	2387.0005129
0.643632241845	0.711672751727	0.598008724933	2391.00051235
0.64185776463	0.711306048864	0.59709504519	2395.00051176
0.642950041205	0.710449189417	0.596167394391	2399.00051123
0.641676076	0.710724557365	0.595866368573	2403.00051146
0.643034538637	0.710036741634	0.594951163024	2407.00051101
0.64234224887	0.709524927353	0.595138149883	2411.00051115
0.642245834767	0.712235381465	0.594550216349	2415.00051161
0.644783428632	0.711979963626	0.5947632590771	2419.00051179
0.64523052322	0.7142069617	0.594888110904	2423.00051174
0.64533531098	0.714275758535	0.596225405378	2427.00051308
0.645990343294	0.713633700223	0.59406697031	2431.00051104
0.644360971062	0.713992307477	0.592124162475	2435.00051099
0.644492544976	0.714975407938	0.594094448279	2439.00051234
0.645129150721	0.716887022563	0.59406482163	2443.00051245
0.645382131462	0.71687555767	0.595467428085	2447.00051251
0.64782033979	0.715377311986	0.595010497194	2451.00051234
0.646436221355	0.716722402949	0.594123851666	2455.0005113
0.647499139549	0.71480333338	0.593763765107	2459.00051207
0.646387117893	0.715395262852	0.592491653766	2463.00051117
0.64597677382	0.716601972599	0.592554395457	2467.00051146
0.647089518991	0.715163590548	0.592662648694	2471.00051151
0.646756037333	0.715984201948	0.591677273865	2475.00051103
0.648296484927	0.716777976978	0.593162639333	2479.00051283
0.648121678003	0.718545318037	0.59336507379	2483.00051183
0.646947682952	0.718180796619	0.592792594253	2487.00051254
0.648531043503	0.7184952899324	0.591498559658	2491.00051179
0.647579604685	0.719892226611	0.590170964931	2495.00051194
0.647404203995	0.720838675179	0.591995233276	2499.0005128
0.647036355775	0.719398668418	0.590936087733	2503.00051211
0.646370779031	0.719611918872	0.589556883125	2507.0005122
0.646863077979	0.719725178905	0.588896291463	2511.0005123
0.646797413733	0.720099357328	0.588059223987	2515.00051099
0.644903891301	0.719344303753	0.586828080917	2519.00051104
0.64505314458	0.720428070352	0.585956117723	2523.00051153
0.645312026502	0.721642507319	0.584761348554	2527.00051177
0.646472389979	0.720732447206	0.584389120398	2531.00051253
0.646361762737	0.722100069541	0.583016413249	2535.00051208
0.645692269691	0.723296378441	0.581439301196	2539.00051218

Figure C-3. Computer Printout from Analysis of Mini Refraction  
Sonde Test at San Diego on 2 May 1978 (Page 16 of 57)



			M=1	S.L.=2532.84638176
			M=2	S.L.=2533.72210007
			M=3	S.L.=2534.58301841
0.647165621173	0.723079630518	0.581222081242		2543.00051293
0.646236282635	0.725139819047	0.57864443702		2547.00051133
0.644591097127	0.722668600048	0.577525912655		2551.00051122
0.645837007026	0.723865093299	0.576884966274		2555.00051246
0.6454607789	0.724767077842	0.57624808429		2559.00051281
0.646509335989	0.724584649064	0.576481294367		2563.00051297
0.645315879376	0.724485027791	0.572541522307		2567.00051051
0.64342614654	0.724114726437	0.571070952584		2571.00051194
0.643928421019	0.723686247614	0.569487118062		2575.00051128
0.642609914727	0.725070841149	0.56790879448		2579.00051223
0.64535739837	0.726446375724	0.566037054304		2583.00051312
0.644262300923	0.726765224406	0.561174088834		2587.00051143
0.642408539487	0.725855441225	0.558848433056		2592.00051146
0.642210526613	0.725070520469	0.556793313227		2596.00051116
0.642276928244	0.726665437264	0.556149124324		2600.0005131
0.642753735763	0.727261761158	0.553631081655		2604.00051183
0.641133730786	0.725975315648	0.549583272139		2608.00051165
0.640245812419	0.727909291249	0.547500566478		2612.0005123
0.641056367639	0.728383913081	0.545268949783		2616.00051207
0.639120506908	0.729025459931	0.542677596388		2620.00051189
0.638809492704	0.728751281759	0.539263845576		2624.00051151
0.638529071033	0.729068144265	0.534622734112		2628.00051216
			M=1	S.L.=2621.63860949
			M=2	S.L.=2622.72875128
			M=3	S.L.=2623.53926385
0.637733891405	0.730684216531	0.532199527332		2632.00051261
0.639071818661	0.730110761073	0.529425455794		2636.00051175
0.636563797944	0.730270856523	0.525817160874		2640.00051171
0.636675954579	0.73004233121	0.522265878348		2644.0005127
0.636383670972	0.731660637913	0.518035299231		2648.00051243
0.635559650031	0.732272162475	0.516509224694		2652.000513
0.635458220234	0.732920408353	0.514161136131		2656.00051292
0.63475386456	0.733104631218	0.511672921221		2660.00051284
0.633104339369	0.732486396161	0.509281969898		2664.00051259
0.632431233433	0.731940793234	0.504751719674		2668.00051171
0.631487602725	0.733226037196	0.501596425101		2672.00051334
0.632642051719	0.733776645241	0.499714619753		2676.00051179
0.629772356354	0.732187611887	0.495774595798		2680.00051071
0.629381698629	0.732157177225	0.496322925462		2684.00051185
0.631156891456	0.733544049769	0.494713765308		2688.00051162
0.62906278317	0.734980557588	0.495054624797		2692.00051284
0.630342721884	0.735697579314	0.496066917554		2696.00051259

Figure C-3. Computer Printout from Analysis of Mini Refraction  
 Sonde Test at San Diego on 2 May 1978 (Page 17 of 57)



			M=1	S.L.=2689.62906278
			M=2	S.L.=2690.73498056
			M=3	S.L.=2691.49505462
0.629876798908	0.733533448913	0.498574843642		2700.00051132
0.628725679685	0.73533299806	0.499032589371		2704.00051219
0.630840204137	0.734986795269	0.499946300394		2708.00051197
0.628237495874	0.734585085164	0.501388385577		2712.00051188
0.628398700208	0.734354605046	0.503309098502		2716.00051206
0.629322635106	0.73537942009	0.506627170532		2720.00051224
0.629163291245	0.736876546051	0.508158967194		2724.00051249
0.629966554266	0.736586593786	0.5079915266		2728.00051166
0.627854542978	0.737903632876	0.507878962033		2732.00051165
0.627443408181	0.736381560957	0.508249567196		2736.00051167
0.62870551402	0.737302296102	0.507479259499		2740.00051203
0.627888944939	0.737809884617	0.508514494398		2744.00051236
0.628455786096	0.738328530259	0.508903476976		2748.00051244
0.627366289918	0.738488928613	0.507066063908		2752.00051211
0.626969361978	0.738729124001	0.50812363213		2756.00051233
0.627111901416	0.738595555043	0.511513717028		2760.00051191
0.626631957972	0.740254580131	0.516821106578		2764.00051273
0.627200119599	0.739931602719	0.521892239351		2768.00051278
			M=1	S.L.=2761.62665196
			M=2	S.L.=2762.74025456
			M=3	S.L.=2763.51682111
0.627427334726	0.739231479878	0.522683403673		2772.00051144
0.626093395652	0.739327529704	0.524976164788		2776.00051278
0.626785889713	0.739856663969	0.52421982492		2780.00051113
0.62572775786	0.741586137954	0.523416661965		2784.00051243
0.626586226168	0.740894901145	0.526286351182		2788.00051285
0.628297898754	0.742762128326	0.528082915887		2792.00051234
0.62672468682	0.741573440236	0.53044065918		2796.00051247
0.627170001936	0.74208787387	0.537590315725		2800.00051173
0.628202189998	0.742194637393	0.537093393639		2804.00051189
0.62576095517	0.742899438341	0.536731013291		2808.00051187
0.62622493869	0.74167934507	0.537531771435		2812.00051187
0.626115746292	0.743659538638	0.537958737861		2817.00051264
0.626902948892	0.743870415506	0.538258265443		2821.00051283
0.626927498412	0.744368259938	0.537231783344		2825.00051224
			M=1	S.L.=2818.62690295
			M=2	S.L.=2819.74387042
			M=3	S.L.=2820.53825527
0.627204041887	0.743918204358	0.536419708403		2829.00051218
0.625664326763	0.743901548126	0.534451077641		2833.00051186
0.624769735269	0.746144775046	0.534159224765		2837.00051294
0.626816352452	0.744835850811	0.533657598034		2841.00051255
0.625379915389	0.743915479079	0.532278679854		2845.00051195
0.624214038916	0.745285481576	0.536234035057		2849.00051322
0.624923854735	0.748147063472	0.531280058269		2853.00051259
0.623371640703	0.74772474976	0.535429540678		2857.0005117
0.623702025406	0.747264664796	0.521890764372		2861.00051283

Figure C-3. Computer Printout from Analysis of Mini Refraction  
Sonde Test at San Diego on 2 May 1978 (Page 18 of 57)



0.623342970902	0.747773709147	0.512207917033	2865.00051171
0.621694701497	0.74734208243	0.514298813082	2869.00051313
0.623753705192	0.746767130934	0.511330787232	2873.00051131
0.621084201625	0.746523470941	0.508331236444	2877.00051169
0.623753705192	0.747165175926	0.503108058062	2881.00051227
0.623115875773	0.748673559377	0.495192300167	2885.00051153
0.620337475312	0.748651922434	0.4910927795851	2889.00051279
0.622439801277	0.748270115416	0.486334511636	2893.00051237
0.621610786427	0.748635435913	0.48335080978	2897.00051157
0.621544892498	0.748767932584	0.4851749453692	2901.00051243
0.620108572537	0.749546302594	0.481184736497	2905.00051134
0.618702550663	0.750880125204	0.475753005235	2909.00051194
0.619766579821	0.750355598252	0.473782532582	2913.00051141
0.618246747476	0.750645579298	0.466037321192	2917.00051179
0.617753793024	0.750227106481	0.467820190142	2921.00051231
0.618516367487	0.751441369133	0.463900155823	2925.00051029
0.617924873916	0.750836382853	0.446226365843	2930.00051122
M=1 S.L.=2925.51851637			
M=2 S.L.=2924.75144127			
M=3 S.L.=2925.46390018			
0.617124304628	0.751333168118	0.435687249717	2934.00051158
0.618332369958	0.752875338275	0.4259443756142	2938.00051232
0.618331180981	0.752939923896	0.414718264537	2942.00051131
0.618275931231	0.753931728175	0.401024376060	2946.00051234
0.613691612685	0.753540701522	0.377600125059	2950.00051214
0.613347142638	0.754108490635	0.307513553194	2954.00051101
M=1 S.L.=2946.7535407			
M=2 S.L.=2943.32940013			
0.613304165164	0.755193992491	0.234021484508	2958.00051277
0.613324884857	0.755850303021	0.189234470193	2962.00051142
M=1 S.L.=2955.61380417			
M=2 S.L.=2956.75519399			
M=3 S.L.=2957.23402148			
0.611517482912	0.755274914849	0.182313563277	2966.00051265
M=1 S.L.=2959.66938486			
M=2 S.L.=2960.7558503			
M=3 S.L.=2961.18923447			
0.610892099246	0.755178310802	0.176795413378	2970.00051244
0.612685938292	0.755672442244	0.171454969127	2974.00051334
0.612060736643	0.75769469576	0.165436710989	2978.00051173
0.610206052962	0.75825476934	0.163728289599	2982.00051293
0.610234348166	0.756531750952	0.162590647281	2986.00051211
0.610443564858	0.757918418092	0.160758798323	2990.00051205
0.610550798175	0.75803229196	0.159932691512	2994.00051237

Figure C-3. Computer Printout from Analysis of Mini Refraction Sonde Test at San Diego on 2 May 1978 (Page 19 of 57)



			M=1	S.L.=2987.61044356
			M=2	S.L.=2988.75791842
			M=3	S.L.=2989.1607588
0.610985948248	0.76002786754	0.158483115431		2998.00051309
0.610046041274	0.759105653726	0.155465762304		3002.0005119
0.610810569727	0.757378818798	0.15182998223		3006.00051247
0.610266082804	0.758877603974	0.147752810638		3010.00051118
0.60930630233	0.758807125799	0.143496956412		3014.00051195
0.610827508939	0.75995727827	0.138425136964		3018.00051267
0.610619759644	0.761234703576	0.131881386143		3022.0005125
0.611795797039	0.762822990693	0.128975327249		3026.00051368
0.612314565735	0.763064777509	0.150141500167		3030.00051281
			M=1	S.L.=3023.6117958
			M=2	S.L.=3024.76282299
			M=3	S.L.=3025.12897533
0.611545480845	0.762691563755	0.179609277423		3034.0005124
0.611300637504	0.760465357848	0.179192540126		3038.00051254
			M=1	S.L.=3031.61154548
			M=2	S.L.=3032.76269156
			M=3	S.L.=3033.17960928
0.610724674966	0.762746324679	0.190887257697		3042.00051163
0.611538323996	0.762943671404	0.205036258985		3046.00051369
			M=1	S.L.=3039.61072468
			M=2	S.L.=3040.76274633
			M=3	S.L.=3041.19088726
0.612253909481	0.764653230498	0.20462474907		3050.00051145
0.610675300032	0.763534865695	0.206286016906		3054.000513
			M=1	S.L.=3047.61225391
			M=2	S.L.=3048.76465323
			M=3	S.L.=3049.20462475
0.612745919702	0.763765634306	0.207849926961		3058.00051289
0.611822480363	0.765691064199	0.24225093059		3062.00051211
			M=1	S.L.=3055.61274592
			M=2	S.L.=3056.76376563
			M=3	S.L.=3057.20784993
0.611411196726	0.763026955184	0.243260598295		3066.00051246
			M=1	S.L.=3059.61162248
			M=2	S.L.=3060.76569106
			M=3	S.L.=3061.24225093
0.611398009031	0.76304109916	0.187707872291		3070.0005132
			M=1	S.L.=3063.6114112
			M=2	S.L.=3064.76302696
			M=3	S.L.=3065.2432606
0.612160519564	0.76509816793	0.193302501882		3074.00051246
			M=1	S.L.=3067.61139801
			M=2	S.L.=3068.7650411
			M=3	S.L.=3069.18770787
0.612201125655	0.765379155771	0.159313921948		3078.000512
			M=1	S.L.=3071.61216052
			M=2	S.L.=3072.76509817
			M=3	S.L.=3073.1933025
0.612052275878	0.766134218752	0.135655697623		3082.00051249
0.611402116905	0.765357036152	0.122282511465		3086.00051217

Figure C-3. Computer Printout from Analysis of Mini Refraction  
Sonde Test at San Diego on 2 May 1978 (Page 20 of 57)



			M=1	S.L.=3079.61205228
			M=2	S.L.=3080.76613422
			M=3	S.L.=3081.1356557
0.612248069735	0.765976220743	0.122418590074		3090.00051217
0.611566425707	0.768385771273	0.122484184014		3094.00051258
			M=1	S.L.=3087.61224807
			M=2	S.L.=3088.76597622
			M=3	S.L.=3089.12241859
0.611579867258	0.766926635031	0.122597793747		3098.00051208
0.610703681985	0.767023586672	0.122564467076		3102.00051228
0.611215803621	0.768002396824	0.136489198145		3106.00051308
			M=1	S.L.=3099.61070368
			M=2	S.L.=3100.76702359
			M=3	S.L.=3101.12256447
0.61148705269	0.768817123658	0.136499222136		3110.00051203
0.611703398823	0.76972271847	0.144682057155		3114.00051341
0.612423936185	0.769577274771	0.140574802235		3118.00051336
			M=1	S.L.=3111.61170339
			M=2	S.L.=3112.76972272
			M=3	S.L.=3113.14468206
0.612372385386	0.76986447183	0.156403689425		3122.00051367
			M=1	S.L.=3115.61242694
			M=2	S.L.=3116.76957727
			M=3	S.L.=3117.1405748
0.610578470004	0.770335215667	0.203319066013		3126.00051217
0.609711397186	0.769109546894	0.199716355386		3130.00051273
			M=1	S.L.=3123.61057847
			M=2	S.L.=3124.77033522
			M=3	S.L.=3125.20331907
0.609821315107	0.770010367677	0.122332576446		3134.00051222
			M=1	S.L.=3127.6097114
			M=2	S.L.=3128.76910955
			M=3	S.L.=3129.19971636
0.608845480415	0.771033590565	0.12312014512		3138.00051292
			M=1	S.L.=3131.60982132
			M=2	S.L.=3132.77001037
			M=3	S.L.=3133.12233258
0.610902995121	0.770983357638	0.123612711547		3142.00051275
0.610312764316	0.770418364126	0.124634205127		3146.00051223
0.6099333680701	0.771443199615	0.12538484135		3150.00051237
0.609355849623	0.770104737254	0.125491042871		3154.00051113
0.60925906268	0.772008927225	0.125771095443		3158.00051277
0.611544333574	0.773840769904	0.126859985645		3162.00051325
0.611600758015	0.774332543504	0.127636214813		3166.00051285
0.610997558407	0.77380215333	0.128316494624		3170.00051199
0.611327358738	0.773070419133	0.129043029979		3174.00051205
0.611925149058	0.774513653939	0.13019673128		3178.00051353
0.613452257158	0.774326872313	0.131235505213		3182.00051315
0.612780068395	0.774178928604	0.131165238739		3186.00051177
0.611755365117	0.775502178122	0.132119750095		3190.00051363
0.613087490265	0.774878402465	0.133027445687		3194.00051234
0.612827319845	0.776484222327	0.133933139935		3198.00051279

Figure C-3. Computer Printout from Analysis of Mini Refraction  
Sonde Test at San Diego on 2 May 1978 (Page 21 of 57)



0.614167079217	0.775946571467	0.135323605541	3202.00051312
0.614299147085	0.777118477091	0.137028427396	3206.00051235
0.613228714438	0.7772973465	0.139395970226	3210.0005129
0.615237709685	0.776732560782	0.141508626779	3214.00051252
0.614889343134	0.777350621777	0.143007505133	3218.00051255
0.613539034241	0.77873977309	0.145462955	3222.00051372
0.616707705637	0.779191594036	0.147745702726	3226.0005126
0.616410816882	0.779951341899	0.151027547467	3230.00051327
0.617345097992	0.778749848246	0.152423084973	3234.00051306
0.616942617993	0.779660372191	0.15363975425	3238.00051171
0.616070892943	0.77768164777	0.155342615345	3242.00051301
0.618252611388	0.779736017761	0.156676436358	3246.00051253
		M=1	S.L.=3239.31307089
		M=2	S.L.=3240.77763165
		M=3	S.L.=3241.15534262
0.618257377145	0.782293014555	0.157279830948	3250.00051406
0.619033418435	0.781435530522	0.158201077185	3254.00051259
0.617896425845	0.779682694357	0.157492853558	3258.00051157
0.615778960409	0.781026353135	0.158961366695	3262.00051209
0.617980648956	0.780690390917	0.160058108864	3266.00051241
0.617706638931	0.780726491167	0.159743756192	3270.00051195
0.617420682588	0.78157649894	0.159926160969	3274.0005129
0.61869216954	0.783410736656	0.161276955137	3278.00051271
0.617427847099	0.783982511924	0.162335977204	3282.00051299
0.618952539474	0.783154231286	0.164000421931	3286.00051313
0.618286833489	0.782006867608	0.165344363949	3290.00051189
0.618098142386	0.783807556983	0.166205540812	3294.00051306
0.619828744514	0.78412462908	0.167340191064	3298.00051223
0.618970265285	0.785045011942	0.168162464129	3302.00051329
0.619317908431	0.784579024659	0.169419569242	3306.0005125
TAGS 3308&3312 FAIL REF COMP;ADD .999			
0.990827589999	0.99065261	0.992984729996	3313.99297498
		M=1	S.L.=3303.61931791
		M=2	S.L.=3304.78457902
		M=3	S.L.=3305.16941957
TAGS 3312&3316 FAIL REF COMP;ADD .999			
0.990904399976	0.9908285	0.990652949996	3317.99294998
		M=1	S.L.=3310.99082759
		M=2	S.L.=3311.99065261
		M=3	S.L.=3312.99298473
TAGS 3316&3320 FAIL REF COMP;ADD .999			
0.999	0.999	0.999	3321.0005121
5.130179961E-4	5.134234058E-4	5.136288154E-4	3325.00051372
		M=1	S.L.=3318.999
		M=2	S.L.=3319.999
		M=3	S.L.=3320.999
5.141816739E-4	5.141291227E-4	5.140765715E-4	3329.00051351
		M=1	S.L.=3322.00051302
		M=2	S.L.=3323.00051342
		M=3	S.L.=3324.00051383
0.619574521891	0.787281669277	0.179634051287	3333.00051331

Figure C-3. Computer Printout from Analysis of Mini Refraction  
Sonde Test at San Diego on 2 May 1978 (Page 22 of 57)



			M=1	S.L.=3326.00051418
			M=2	S.L.=3327.00051413
			M=3	S.L.=3328.00051408
0.620040831387	0.786924227504	0.181930774512		3337.00051243
			M=1	S.L.=3330.61957452
			M=2	S.L.=3331.78728167
			M=3	S.L.=3332.17963405
0.620513328697	0.787085816714	0.183769595119		3341.00051234
0.6208725827	0.788820329836	0.185401592119		3345.0005133
0.621784976588	0.788379681558	0.188189036586		3349.00051306
0.621793857038	0.7890020435	0.189866699602		3353.00051269
0.62219293732	0.787793990299	0.190293748751		3357.00051223
0.62205425679	0.789779457721	0.191359773341		3361.00051273
0.621549145821	0.790241825252	0.193181258151		3365.00051332
0.623362725485	0.789347289676	0.195098922013		3369.0005122
0.621899890486	0.789559321218	0.196566228787		3373.00051159
0.622646480823	0.790239715142	0.198091164612		3377.00051294
0.624397400742	0.789555102498	0.199275934579		3381.00051285
0.623645800734	0.791729031055	0.201347869712		3385.00051312
0.624669719323	0.791333052054	0.203247662893		3389.00051278
0.623773871398	0.79004749231	0.20417231229		3393.00051188
0.62370627916	0.793478420862	0.20609606168		3397.00051331
0.625741953816	0.793641210746	0.207602310377		3401.00051363
0.626001520264	0.794400469288	0.207976513881		3405.00051237
0.623583762314	0.792675938001	0.208921862772		3409.00051256
0.624392403645	0.792850066371	0.21077967464		3413.0005125
0.625309517319	0.794401061455	0.211410445166		3417.00051304
0.625258837597	0.795614384207	0.212955555359		3421.00051413
0.625980505209	0.795888323648	0.213794449467		3425.00051333
0.625239012194	0.795572522288	0.215184312705		3429.00051342
0.626588605991	0.795062907931	0.215760466406		3434.00051272
0.625814549896	0.796775234264	0.217085911133		3438.00051316
0.625690595464	0.796479477575	0.217699442443		3442.00051261
0.625963124768	0.795912188912	0.218416231881		3446.0005127
0.625935057373	0.796032016877	0.22095715609		3450.00051364
0.627466674026	0.797492932368	0.221767852308		3454.00051318
0.625863080532	0.797199210432	0.222963101611		3458.00051264
0.626415925412	0.797523296878	0.224542715331		3462.00051264
0.627024415988	0.797563290647	0.225282188243		3466.0005125
0.627199954208	0.797267861588	0.22554120566		3470.00051234
0.628451363224	0.799075978559	0.225264098759		3474.00051329
0.626828033119	0.797966022444	0.224090062627		3478.00051066
0.626212465598	0.797796581117	0.225365332771		3482.00051328
0.6289845223	0.800663078243	0.224842367994		3486.00051309
0.628480518742	0.801420046241	0.225334402272		3490.00051292

Figure C-3. Computer Printout from Analysis of Mini Refraction  
Sonde Test at San Diego on 2 May 1978 (Page 23 of 57)



			M=1	S.L.=3483.62898452
			M=2	S.L.=3484.80066308
			M=3	S.L.=3485.22484237
0.627843377655	0.800789416206	0.223882712316		3494.00051366
0.628337518886	0.799886143864	0.225448078402		3498.00051205
0.627321762237	0.799686461697	0.226922141414		3502.00051326
0.628561629166	0.800980575854	0.225319192023		3506.0005127
0.627980568305	0.800930196201	0.226065720026		3510.00051193
0.624336902183	0.800459253011	0.227176249154		3514.00051293
0.629330651118	0.802926876579	0.228540376055		3518.00051313
0.629151701495	0.802433036761	0.229303873945		3522.00051323
0.630483521879	0.803335524668	0.231238060792		3526.00051324
0.629507284092	0.802894172523	0.231130417419		3530.00051285
0.628662178489	0.802748920458	0.233074590002		3534.00051352
0.630348835608	0.802573866348	0.23315050963		3538.00051294
0.628503155785	0.803094365624	0.236913595421		3542.00051274
0.629423422673	0.804330449502	0.241240497391		3546.00051365
TAGS 35481352 FAIL REF COMP ADD .999				
0.990813809996	0.990814	0.990636749994		3553.99211215
			M=1	S.L.=3543.62942342
			M=2	S.L.=3544.80433045
			M=3	S.L.=3545.2412405
TAGS 355513559 FAIL REF COMP ADD .999				
0.992111359984	0.99211203	0.99211029999		3560.99210481
			M=1	S.L.=3550.99081381
			M=2	S.L.=3551.990814
			M=3	S.L.=3552.99063675
TAGS 356213566 FAIL REF COMP ADD .999				
0.997	0.997	0.997		3567.00051154
5.124799771E-4	5.12707902E-4	5.133358329E-4		3574.00051325
			M=1	S.L.=3564.999
			M=2	S.L.=3565.999
			M=3	S.L.=3566.999
5.137367803E-4	5.137137128E-4	5.136886873E-4		3581.00051315
			M=1	S.L.=3571.00051248
			M=2	S.L.=3572.00051291
			M=3	S.L.=3573.00051334
5.131526301E-4	5.131501306E-4	5.13147631E-4		3588.00051314
5.129051285E-4	5.128651255E-4	5.124251226E-4		3595.00051218
5.124251226E-4	5.126651255E-4	5.129051285E-4		3602.00051314
5.131351302E-4	5.13125129E-4	5.131151277E-4		3609.0005131
5.133576302E-4	5.136101338E-4	5.138626375E-4		3616.00051411
5.139526391E-4	5.13790137E-4	5.136276349E-4		3623.00051346
5.132651313E-4	5.130651277E-4	5.128651282E-4		3630.00051286
5.127401272E-4	5.128151277E-4	5.128901282E-4		3637.00051296
5.127201265E-4	5.124751243E-4	5.122501221E-4		3644.00051198
5.124251226E-4	5.126651255E-4	5.133051298E-4		3651.00051374
5.134784577E-4	5.132401302E-4	5.129876288E-4		3658.00051273
5.127701267E-4	5.128051261E-4	5.128401254E-4		3662.00051287
5.129651267E-4	5.130551286E-4	5.131451305E-4		3669.00051323
5.131701317E-4	5.131051311E-4	5.130401304E-4		3676.00051297

Figure C-3. Computer Printout from Analysis of Mini Refraction Sonde Test at San Diego on 2 May 1978 (Page 24 of 57)



5.129276297E-4	5.128801276E-4	5.128326266E-4	3683.00051278
5.128301265E-4	5.128751276E-4	5.129201266E-4	3690.00051296
5.129551292E-4	5.129451288E-4	5.129351284E-4	3697.00051292
5.130026291E-4	5.130801302E-4	5.131576313E-4	3704.00051323
5.130426304E-4	5.128501284E-4	5.126576265E-4	3711.00051246
5.124651246E-4	5.124651246E-4	5.124651246E-4	3718.00051246
5.125551255E-4	5.126451254E-4	5.127351258E-4	3725.00051282
5.129076276E-4	5.129901289E-4	5.130726302E-4	3732.00051315
5.133101327E-4	5.134651338E-4	5.136201349E-4	3739.00051377
5.135976346E-4	5.134201333E-4	5.13242632E-4	3746.00051306
5.129526292E-4	5.128401277E-4	5.127276263E-4	3750.00051261
5.126251253E-4	5.126351257E-4	5.126451261E-4	3757.00051265
5.126986752E-4	5.127426238E-4	5.168799162E-4	3764.00051283
5.128738696E-4	5.129176182E-4	5.129613668E-4	3768.000513
5.130326194E-4	5.130601233E-4	5.130876272E-4	3773.00051311
5.178907641E-4	5.180048108E-4	5.173078142E-4	3777.0005132
0.810025966202	0.259679066605	5.132638798E-4	3781.00051328
		M=1	S.L.=3774.00051789
		M=2	S.L.=3775.000518
		M=3	S.L.=3776.00051731
0.633914999315	0.810076906511	0.259991632002	3785.00051265
		M=1	S.L.=3778.81002597
		M=2	S.L.=3779.25967907
		M=3	S.L.=3780.00051326
0.634441712267	0.810940234116	0.263176506531	3789.00051353
		M=1	S.L.=3782.633915
		M=2	S.L.=3783.81007691
		M=3	S.L.=3784.25999163
0.635953212325	0.811282272917	0.263980225665	3793.00051331
0.634222448278	0.81166620848	0.263321567307	3797.00051249
0.634878473433	0.81187397452	0.264340145395	3801.00051367
0.635611944465	0.811172598382	0.266037528573	3805.00051222
0.634908131491	0.812138758201	0.267664355355	3809.00051356
0.636793081461	0.81277331904	0.269206825194	3813.00051229
0.635331005476	0.812188917923	0.270074984406	3817.00051253
0.635727996989	0.812471255177	0.274954675163	3821.00051276
0.63772114415	0.813961384857	0.27833792732	3825.00051332
0.63763303772	0.81638653257	0.281996181804	3829.00051355
0.638035440513	0.818175447793	0.285582218968	3833.00051362
0.638479890466	0.816240194701	0.289077086911	3837.0005129
0.639104533265	0.815004920058	0.294420743084	3841.0005129
		M=1	S.L.=3834.63847989
		M=2	S.L.=3835.81624019
		M=3	S.L.=3836.26907707
0.639465799876	0.81538130746	0.298876387573	3845.00051339
0.638851186075	0.81741200343	0.301870715046	3849.00051274

Figure C-3. Computer Printout from Analysis of Mini Refraction Sonde Test at San Diego on 2 May 1978 (Page 25 of 57)



0.6339914862004	0.817682024419	0.311010260602	3853.0005135
0.641122017271	0.817403691195	0.315526798698	3857.00051311
0.639786644953	0.81777248711	0.320715760365	3861.00051308
0.642095995422	0.818362329121	0.324986221328	3865.00051313
0.641439179218	0.818920079297	0.329754963318	3869.00051242
0.64072964623	0.818622041129	0.337762833271	3873.00051369
0.642920647372	0.819054302973	0.340908632105	3877.00051211
0.640760816742	0.818815305132	0.344158000211	3881.0005129
0.643528133131	0.819566634237	0.347744368434	3885.00051364
0.644865585123	0.820196608509	0.350600298552	3889.00051259
0.643482210112	0.821937658726	0.354277339016	3893.00051378
0.644973742674	0.821788033555	0.357824820284	3897.00051334
0.6438986600966	0.821560135969	0.356402924965	3901.0005126
		M=1	S.L.=3894.64497374
		M=2	S.L.=3895.82178803
		M=3	S.L.=3896.35782462
0.643890291794	0.821166177706	0.359292410623	3905.00051348
0.645555360475	0.822041760531	0.361248188675	3909.00051302
0.643875872284	0.824058897513	0.364588089706	3913.00051323
0.646165787309	0.823731768103	0.369056060616	3917.00051398
0.645808971013	0.823074826053	0.36655716202	3921.00051274
0.645898661056	0.823397212652	0.372132319515	3925.00051318
0.647082367534	0.822627193153	0.374945172401	3929.00051285
0.646063731386	0.824829963731	0.375398504456	3933.00051309
0.646758169851	0.825268166564	0.3765628899116	3937.00051323
0.646808724124	0.823604561561	0.378874251032	3941.00051168
0.643604492977	0.824045171857	0.379633605327	3945.00051274
0.648282807728	0.825348463636	0.381264191577	3949.00051401
0.646742560624	0.827464844459	0.382885010745	3953.00051342
0.648058887661	0.82852058255	0.385812378689	3957.00051432
0.649669783023	0.827535109772	0.386375624893	3961.00051328
0.648661109573	0.827284441975	0.386772191166	3965.00051338
0.649241266087	0.827134035563	0.387989526577	3969.00051354
0.650512573959	0.826850924356	0.381521055404	3973.00051334
		M=1	S.L.=3966.64924127
		M=2	S.L.=3967.62713404
		M=3	S.L.=3968.36798933
0.650063936363	0.829565837603	0.376503218665	3977.00051344
0.651013198462	0.828881714167	0.380988350214	3981.00051309
0.651505914173	0.82945637053	0.379686700697	3985.00051313
0.651782081181	0.830122142376	0.379792316464	3989.00051315
		M=1	S.L.=3982.66150591
		M=2	S.L.=3983.62948667
		M=3	S.L.=3984.37968667
0.652925339512	0.829488509861	0.378552507945	3993.00051306
0.653616604312	0.832206117205	0.380799625283	3997.00051315
0.654163738631	0.832147768923	0.385262989541	4001.00051397
0.654838682721	0.831271950444	0.38284821965	4005.000513
0.653804734637	0.830488033195	0.384770332957	4009.00051345
0.655178784286	0.830897220051	0.38675512639	4013.00051319

TIME-TAGGED PERIOD RATIOS BEFORE GAP PROCESSING

Figure C-3. Computer Printout from Analysis of Mini Refraction Sonde Test at San Diego on 2 May 1978 (Page 26 of 57)







Figure C-3. Computer Printout from Analysis of Mini Refraction Sonde Test at San Diego on 2 May 1978 (Page 28 of 57)







Figure C-3. Computer Printout from Analysis of Mini Refraction Sonde Test at San Diego on 2 May 1978 (Page 30 of 57)







Figure C-3. Computer Printout from Analysis of Mini Refraction Sonde Test at San Diego on 2 May 1978 (Page 32 of 57)



INVALID SAMPLE - 1280.99124913  
 INVALID SAMPLE - 1291.999  
 INVALID SAMPLE - 1353.99081259  
 INVALID SAMPLE - 1361.999  
 INVALID SAMPLE - 1991.99075042  
 INVALID SAMPLE - 1999.999  
 INVALID SAMPLE - 3566.999  
 INVALID SAMPLE - 3776.00051731  
 INVALID SAMPLE - 3780.00051326

PERIOD RATIOS AFTER GAP PROCESSING

1	5.54002542785	61.5434512669	161.549870629
333.559611482	805.589451635	1237.60631022	1273.61210663
1278.61209973	1289.61208454	1293.61207902	1297.6120735
1301.61195478	1316.61221925	1320.61223062	1336.6122761
1340.61228747	1344.61253198	1351.6126197	1359.61271998
1363.61277012	1367.61282027	1373.61394339	1377.61406965
1381.61419594	1385.61615669	1393.61391012	1397.61478078
1405.61414424	1433.61354266	1437.61360962	1441.61367658
1445.61471547	1502.61777016	1506.61758441	1510.61790765
1514.6188877	1709.62288089	1716.6229164	1720.62293669
1725.62296205	1729.62333756	1733.62255206	1737.62288786
1781.62701509	1785.62717613	1789.62733721	1793.62983922
1950.63733628	1964.6373888	1968.63744132	1972.63825603
1984.63823529	1989.63816164	1997.63804382	2001.63798492
2005.63792603	2009.63672723	2062.64271043	2068.64192023
2072.6420039	2076.64208759	2080.64338609	2532.64636176
2621.63980949	2689.62906278	2761.62663196	2818.62690295
2854.62337164	2923.61851637	2947.61369161	2955.61380417
2959.61238488	2987.61044356	3023.6117958	3031.61154548
3039.61072468	3047.61225391	3055.61274592	3059.61162246
3063.6114112	3067.61139801	3071.61216052	3079.61205226
3087.61224807	3099.61070368	3111.6117034	3115.61242694
3123.61057847	3127.6097114	3131.60982132	3239.61607089
3303.61931791	3310.61933462	3318.61935371	3322.61936326
3326.6193728	3330.61957452	3483.62898452	3543.62942342
3550.62947257	3564.62957087	3571.62962003	3774.63104727
3778.63107543	3782.633915	3834.63247989	3894.64497374
3966.64924127	3982.65150591	0	0

Figure C-3. Computer Printout from Analysis of Mini Refraction Sonde Test at San Diego on 2 May 1978 (Page 33 of 57)





Figure C-3. Computer Printout from Analysis of Mini Refraction  
Sonde Test at San Diego on 2 May 1978 (Page 34 of 57)





Figure C-3. Computer Printout from Analysis of Mini Refraction Sonde Test at San Diego on 2 May 1978 (Page 35 of 57)







110

Figure C-3. Computer Printout from Analysis of Mini Refraction Sonde Test at San Diego on 2 May 1978 (Page 37 of 57)





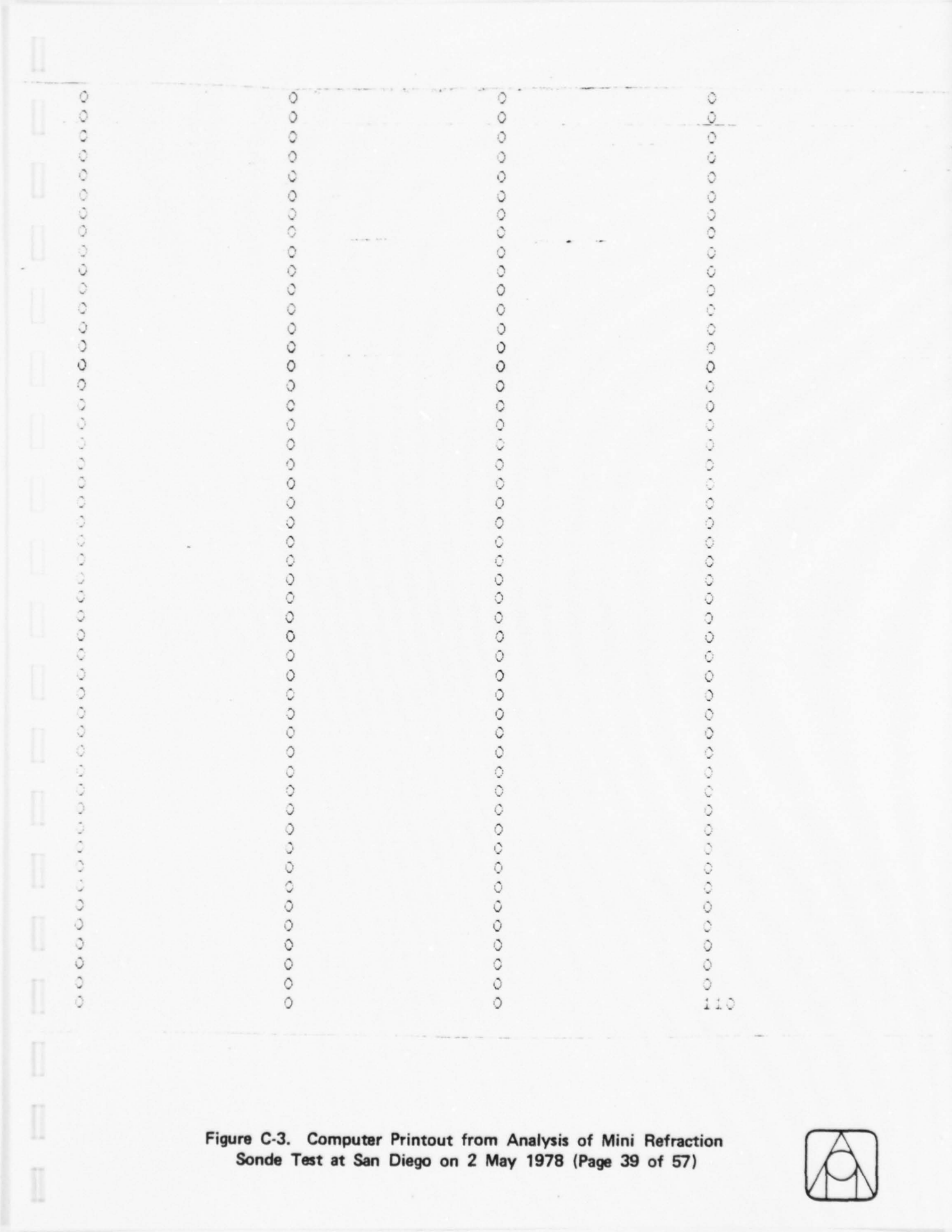

110

Figure C-3. Computer Printout from Analysis of Mini Refraction Sonde Test at San Diego on 2 May 1978 (Page 39 of 57)



OPR-ENTERED EST OF SURF PRES= 1011.1 MB

T4 = 15 DEG C

TIME TAG, TEMP, PRES, HUM= 15 2.82469127439 689.861966875 48.5617697307

PRES COEF L(3,6) ARE AS FOLLOWS:

35.00426	3.77062	-0.18574	3.58264
-0.01778997	3.04286E-5		
533.173	-66.71563	2.76587	0.8233251
0.00108737	-1.613306E-6		
0.77706	-0.17717	0.010342	6.21053
-0.031607	4.571193E-5		

TIME TAG, TEMP, PRES, HUM= 3982 16.6853776844 1008.37834958 64.3631736131

PRES COEF L(3,6) ARE AS FOLLOWS:

35.00426	3.77062	-0.18574	3.58264
-0.01778997	3.04286E-5		
533.173	-66.71563	2.76587	0.8233251
0.00108737	-1.613306E-6		
0.77706	-0.17717	0.010342	6.21053
-0.031607	4.571193E-5		

Figure C-3. Computer Printout from Analysis of Mini Refraction  
Sonde Test at San Diego on 2 May 1978 (Page 40 of 57)







Figure C-3. Computer Printout from Analysis of Mini Refraction  
Sonde Test at San Diego on 2 May 1978 (Page 42 of 57)







Figure C-3. Computer Printout from Analysis of Mini Refraction  
Sonde Test at San Diego on 2 May 1978 (Page 44 of 57)







Figure C-3. Computer Printout from Analysis of Mini Refraction  
Sonde Test at San Diego on 2 May 1978 (Page 46 of 57)







Figure C-3. Computer Printout from Analysis of Mini Refraction Sonde Test at San Diego on 2 May 1978 (Page 48 of 57)







Figure C-3. Computer Printout from Analysis of Mini Refraction  
Sonde Test at San Diego on 2 May 1978 (Page 50 of 57)







Figure C-3. Computer Printout from Analysis of Mini Refraction Sonde Test at San Diego on 2 May 1978 (Page 52 of 57)



DETAILED LIST OF ATMOSPHERIC PARAMETERS

ALT(FT)	ALT(M)	PR(MB)	T(DEG-C)	RH(%)	N-UNITS	M-UNITS	G/M3	D-PT-DEP	N/M	N/M-CLASS
10700.	3261.	685.5	2.75	48.8	210.6	724.	2.89	9.7		
									-0.0261	NORML-
10529.	3209.	689.9	3.17	48.6	212.0	717.	2.96	9.8		
									-0.0144	NORML-
10253.	3125.	697.1	3.95	45.6	213.2	705.	2.93	10.7		
									-0.0275	NORML-
9692.	2954.	711.9	5.13	45.6	217.9	683.	3.17	10.8		
									-0.0247	NORML-
8329.	2539.	748.8	8.81	41.5	228.1	628.	3.66	12.4		
									-0.0285	NORML-
7164.	2184.	781.5	10.91	41.0	238.2	582.	4.14	12.7		
									-0.0320	NORML-
6977.	2127.	786.9	11.64	40.7	240.1	575.	4.30	12.9		
									-0.1476	SPRF--
6977.	2127.	786.9	11.64	40.7	240.1	575.	4.30	12.9		
									-0.1373	SPRF--
6978.	2127.	786.8	11.64	40.7	240.0	575.	4.29	12.9		
									-0.1435	SPRF--
6978.	2127.	786.8	11.64	40.7	240.0	575.	4.29	12.9		
									-0.1435	SPRF--
6978.	2127.	786.8	11.64	40.7	240.0	575.	4.29	12.9		
									-0.1051	SPRF--
6981.	2128.	786.7	11.62	40.6	239.9	575.	4.28	12.9		
									-0.7030	TRP---
6981.	2128.	786.8	11.65	40.8	240.1	575.	4.31	12.9		
									-0.0185	NORML-
6977.	2126.	786.9	11.66	40.8	240.1	575.	4.31	12.9		
									-0.0182	NORML-
6960.	2122.	787.3	11.66	40.7	240.2	574.	4.30	12.9		
									-0.0253	NORML-
6879.	2097.	789.7	11.66	40.7	240.8	571.	4.30	12.9		
									-0.0252	NORML-
6976.	2126.	786.9	11.69	40.7	240.1	575.	4.31	12.9		
									-0.0224	NORML-
6966.	2123.	787.2	11.70	40.7	240.2	575.	4.31	12.9		
									-0.0225	NORML-
6955.	2120.	787.5	11.72	40.6	240.2	574.	4.31	12.9		
									-0.0225	NORML-
6949.	2118.	787.7	11.72	40.6	240.3	574.	4.31	12.9		
									-0.0225	NORML-
6943.	2116.	787.8	11.73	40.6	240.3	574.	4.31	12.9		
									-0.0282	NORML-
6816.	2077.	791.5	11.87	40.6	241.4	569.	4.34	13.0		
									-0.0505	NORML-
6816.	2077.	791.5	11.89	40.6	241.4	569.	4.34	13.0		
									-0.0505	NORML-
6815.	2077.	791.5	11.90	40.5	241.4	569.	4.35	13.0		
									0.0707	SUBFR+

Figure C-3. Computer Printout from Analysis of Mini Refraction Sonde Test at San Diego on 2 May 1978 (Page 53 of 57)



6811.	2076.	791.6	12.15	40.1	241.3	568.	4.28	13.2	-0.0536	NORML-
6843.	2086.	790.7	11.87	40.0	240.8	569.	4.28	13.2	-0.1868	TRP---
6838.	2084.	790.9	11.98	40.2	241.1	569.	4.33	13.1	-0.0220	NORML-
6777.	2066.	792.6	11.90	40.2	241.5	567.	4.30	13.1	-0.0191	NORML-
6689.	2039.	795.2	11.82	40.0	242.0	563.	4.26	13.2	-0.0424	NORML-
6687.	2038.	795.2	11.83	40.0	242.0	563.	4.27	13.2	-0.0424	NORML-
6685.	2038.	795.3	11.84	40.0	242.0	563.	4.27	13.2	-0.0399	NORML-
6658.	2029.	796.1	11.97	40.0	242.4	562.	4.31	13.2	-0.0281	NORML-
6597.	2011.	797.9	12.35	39.6	242.9	560.	4.37	13.3	0.0046	SUBFR+
6592.	2009.	798.0	12.33	39.6	242.9	559.	4.36	13.3	-0.0175	NORML-
6586.	2008.	798.2	12.37	39.5	242.9	559.	4.36	13.4	-0.0255	NORML-
6507.	1983.	800.5	12.50	39.3	243.5	556.	4.38	13.4	-0.0290	NORML-
5992.	1826.	815.6	13.00	39.4	248.1	536.	4.53	13.5	0.0039	SUBFR+
5977.	1822.	816.0	13.01	39.2	248.1	535.	4.50	13.5	-0.0144	NORML-
5979.	1822.	816.0	13.01	39.2	248.0	535.	4.50	13.5	-0.0148	NORML-
5981.	1823.	815.9	13.01	39.2	248.0	535.	4.51	13.5	-0.0207	NORML-
6006.	1831.	815.2	13.06	39.2	247.9	536.	4.52	13.5	-0.0185	NORML-
5973.	1821.	816.1	12.96	39.2	248.1	535.	4.49	13.5	-0.0309	NORML-
5918.	1804.	817.8	13.00	39.3	248.6	533.	4.51	13.5	-0.0310	NORML-
5811.	1771.	821.0	13.53	38.9	249.6	529.	4.61	13.7	-0.0394	NORML-
5784.	1763.	821.8	13.55	39.0	249.9	528.	4.64	13.7	-0.0273	NORML-
5799.	1768.	821.3	13.57	39.0	249.8	528.	4.64	13.7	0.1570	SUBFR+
5803.	1769.	821.2	13.89	38.9	250.0	529.	4.72	13.7	-0.0291	NORML-
5318.	1621.	835.7	14.85	38.3	254.3	510.	4.93	14.0	-6.8898	TRP---
5318.	1621.	835.7	14.86	38.3	254.3	510.	4.93	14.1	-7.2178	TRP---
5318.	1621.	835.7	14.86	38.3	254.3	510.	4.93	14.1	-1.7597	TRP---

Figure C-3. Computer Printout from Analysis of Mini Refraction Sonde Test at San Diego on 2 May 1978 (Page 54 of 57)



5318.	1621.	835.7	14.97	38.0	254.1	509.	4.92	14.2		
5237.	1596.	838.1	14.97	37.8	254.7	506.	4.90	14.2	-0.0222	NORML-
5237.	1596.	838.2	14.96	37.8	254.7	506.	4.90	14.2	0.0000	SUBFR+
5236.	1596.	838.2	14.94	37.9	254.7	506.	4.90	14.2	0.0000	SUBFR+
5235.	1596.	838.2	14.93	37.9	254.7	506.	4.90	14.2	0.0000	SUBFR+
5235.	1596.	838.2	14.93	37.9	254.7	506.	4.89	14.2	-0.0067	NORML-
5225.	1592.	838.5	14.77	37.9	254.7	505.	4.85	14.2	0.0066	SUBFR+
5014.	1528.	844.9	15.54	38.1	257.2	498.	5.11	14.2	-0.0399	NORML-
5037.	1535.	844.2	15.44	38.1	256.9	499.	5.08	14.2	-0.0445	NORML-
5032.	1534.	844.4	15.45	38.0	256.9	498.	5.08	14.2	-0.0193	NORML-
5028.	1533.	844.5	15.46	38.0	257.0	498.	5.08	14.2	-0.0193	NORML-
4957.	1511.	846.6	15.63	37.8	257.5	495.	5.09	14.3	-0.0247	NORML-
3740.	1140.	884.5	16.02	42.3	271.7	451.	5.84	12.3	-0.0384	NORML-
3503.	1080.	892.1	15.04	48.7	277.6	445.	6.33	10.7	-0.0810	SFRF--
3236.	1101.	889.1	13.79	53.6	281.5	439.	6.47	9.2	-0.0588	NORML-
3101.	745.	905.1	13.48	51.2	281.0	430.	6.06	9.9	0.0083	SUBFR+
2974.	905.	909.3	13.51	48.7	280.4	423.	5.77	10.6	0.0161	SUBFR+
2841.	885.	913.7	13.07	50.2	282.1	418.	5.79	10.1	-0.0429	NORML-
2714.	827.	917.9	12.45	56.6	286.8	417.	6.28	8.4	-0.1214	SFRF--
2644.	806.	920.3	11.84	63.9	291.3	418.	6.82	6.6	-0.2098	TRF---
2587.	789.	922.2	11.85	75.9	299.5	424.	8.12	4.1	-0.4747	TRF---
2505.	782.	922.9	11.67	80.3	302.2	425.	8.49	3.3	-0.3953	TRF---
2495.	761.	925.2	11.43	83.7	304.4	424.	8.71	2.6	-0.1046	SFRF--
2328.	709.	930.9	11.60	88.7	309.4	421.	9.33	1.8	-0.0989	SFRF--
2332.	711.	930.8	11.57	81.4	304.7	417.	8.55	3.1	-3.3647	TRF---
2301.	710.	930.8	11.47	80.1	303.7	415.	8.36	3.3	2.1953	SUBFR+
									-0.0057	NORML-

Figure C-3. Computer Printout from Analysis of Mini Refraction  
Sonde Test at San Diego on 2 May 1978 (Page 55 of 57)



2265.	690.	933.0	11.66	78.7	303.9	413.	8.31	3.6	-0.0385	NORML-
2295.	700.	932.0	11.72	78.4	303.5	414.	8.31	3.6	0.0849	SUBFR+
2230.	680.	934.2	11.60	75.1	301.8	409.	7.91	4.2	-0.0532	NORML-
2253.	687.	933.5	11.55	75.0	301.5	410.	7.87	4.3	-23.7756	TRP---
2253.	687.	933.5	11.55	80.5	304.9	413.	8.44	3.2	0.2202	SUBFR+
2250.	686.	933.5	11.65	79.9	304.7	413.	8.43	3.3	-0.4758	TRP---
2215.	675.	934.7	11.63	87.5	309.8	416.	9.22	2.0	1.0017	SUBFR+
2221.	677.	934.6	11.66	90.0	311.4	418.	9.51	1.6	0.0173	SUBFR+
2186.	666.	935.7	11.46	90.0	311.2	416.	9.39	1.6	0.0476	SUBFR+
2094.	638.	938.9	11.59	86.0	309.9	410.	9.04	2.3	0.4183	SUBFR+
2099.	640.	938.7	11.68	86.7	310.5	411.	9.17	2.1	0.6907	SUBFR+
2074.	632.	939.6	11.45	78.8	305.3	405.	8.21	3.5	-0.0303	NORML-
2118.	645.	938.1	11.34	79.2	304.9	406.	8.20	3.5	-0.7580	TRP---
2085.	636.	939.2	11.35	90.0	311.9	412.	9.32	1.6	-0.0102	NORML-
1823.	556.	948.1	12.14	84.5	312.7	400.	9.20	2.5	-0.0276	NORML-
1594.	486.	956.1	12.55	82.7	314.7	391.	9.24	2.8	0.0084	SUBFR+
1588.	484.	956.3	12.55	82.6	314.7	391.	9.22	2.9	0.0083	SUBFR+
1551.	482.	956.5	12.56	82.5	314.6	391.	9.21	2.9	0.0079	SUBFR+
1578.	481.	956.7	12.56	82.4	314.6	390.	9.20	2.9	0.0088	SUBFR+
1575.	480.	956.8	12.56	82.3	314.6	390.	9.20	2.9	-0.0076	NORML-
1504.	458.	959.2	12.58	81.5	314.8	387.	9.12	3.1	-0.0282	NORML-
1059.	323.	974.8	13.78	77.0	318.6	369.	9.27	4.0	-0.0056	NORML-
939.	286.	979.0	13.84	75.5	318.8	364.	9.12	4.3	-0.0333	NORML-
937.	286.	979.1	13.84	75.5	318.8	364.	9.13	4.3	-0.0325	NORML-
933.	284.	979.3	13.86	75.4	318.9	364.	9.13	4.3	-0.0333	NORML-
931.	284.	979.3	13.86	75.4	318.9	364.	9.13	4.3	-0.0329	NORML-

Figure C-3. Computer Printout from Analysis of Mini Refraction Sonde Test at San Diego on 2 May 1978 (Page 56 of 57)



871.	265.	981.5	14.04	74.9	319.5	361.	9.17	4.4	
870.	265.	981.5	14.05	74.9	319.5	361.	9.17	4.4	-0.0303 NORML-
750.	229.	985.7	14.41	73.9	320.7	357.	9.25	4.6	-0.0342 NORML-
549.	167.	992.9	15.00	71.5	322.2	349.	9.28	5.1	-0.0237 NORML-
367.	112.	999.4	15.84	66.1	321.5	339.	9.02	6.3	0.0131 SUBFR+
193.	59.	1005.7	16.39	63.6	322.3	332.	8.99	6.9	-0.0163 NORML-
118.	36.	1005.4	16.69	64.4	324.3	330.	9.25	6.7	-0.0847 SPRF--

SIGNIF LEVS (T1,H10) LIST OF ATMOSPHERIC PARAMETERS

ALT(FT)	ALT(M)	PR(MB)	T(DEG-C)	RH(%)	N-UNITS	M-UNITS	G/M3	D-PT-DEP
118.	36.	1008.4	16.69	64.4	324.3	330.	9.25	6.7
2085.	636.	739.2	11.35	70.0	311.9	412.	9.32	1.6
2115.	645.	735.1	11.34	72.2	304.9	406.	8.20	3.5
2174.	662.	737.6	11.45	73.8	305.3	405.	8.21	3.5
2215.	675.	734.7	11.63	67.5	309.8	416.	9.22	2.0
2250.	687.	733.5	11.55	75.0	301.5	410.	7.87	4.3
2322.	709.	730.9	11.60	68.7	309.4	421.	9.33	1.8
2367.	733.	722.2	11.65	73.9	299.5	424.	8.12	4.1
2441.	756.	713.7	13.07	50.2	282.1	418.	5.79	10.1
3740.	1140.	584.5	16.02	42.3	271.7	451.	5.84	12.8
3803.	1169.	581.2	13.69	38.9	250.0	529.	4.72	13.7
3784.	1163.	581.8	13.55	39.0	249.9	525.	4.64	13.7
3829.	1209.	589.9	5.17	45.5	212.0	717.	2.95	9.8

MANDATORY LEVELS

ALT(FT)	ALT(M)	PR(MB)	T(DEG-C)	RH(%)	N-UNITS	M-UNITS	G/M3	D-PT-DEP
118.	36.	1008.4	16.67	64.3	324.2	330.	9.24	6.7
193.	60.	1000.0	16.38	63.7	322.3	332.	8.99	6.9
3740.	1141.	580.0	16.01	42.3	271.7	451.	5.84	12.8
3898.	1196.	700.0	5.12	45.5	217.8	583.	3.17	10.8

Figure C-3. Computer Printout from Analysis of Mini Refraction Sonde Test at San Diego on 2 May 1978 (Page 57 of 57)





APPENDIX D  
PROGRAM LISTING FOR BAROSWITCH DROPSONDE ANALYSIS



AD-A062 397

ANALYTICS INC WILLOW GROVE PA F/G 4/1  
BREADBOARD DROPSONDE-MINIREFRACTIONSONDE ANALYZER. VOLUME 1.(U)  
NOV 78 M C WERST N62269-77-C-0095

UNCLASSIFIED

NADC-76335-30

NL

3 OF 3  
ADA  
062397



3 OF  
ADA

3

062397

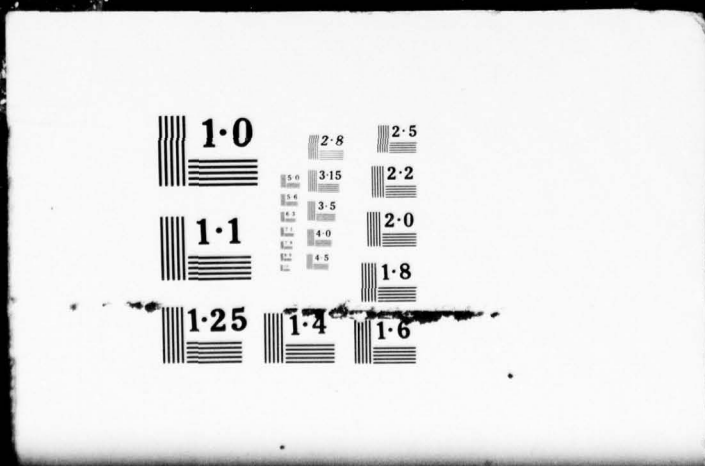

APPENDIX D. PROGRAM LISTING FOR BAROSWITCH DROPSONDE ANALYSIS

The four program files of Cassette V, Baroswitch Dropsonde Analysis, are listed in the four figures of this appendix as tabulated below.

<u>Cassette Number</u>	<u>File on Cassette</u>	<u>Program Name</u>	<u>Figure Number</u>
V	1	CALIBRATION AND ACQUISITION	D-1
V	2	REDUCED DATA FILE BUILDER	D-2
V	3	TEMP, PRES, HUM TABLE BUILDER	D-3
V	4	OUTPUT REPORT GENERATOR	D-4

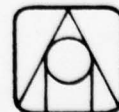

```

100 GO TO 1000
110 DELETE 1000,3110
120 PRINT 'SET HP AS ADDR 3 FOR INPUT. ENTER MINUTES OF DATA ( <10.9 )'
130 INIT
140 Y=0
150 DELETE T
160 INPUT M
170 M=320*M+160
180 DIM Z$(2),T(M),U$(17),T$(14)
190 PRINT @3,32:'PF7G1S17;R'
200 ON SRQ THEN 220
210 WAIT
220 FOR N=1 TO M
230 INPUT @3:U$
240 T$=SEG(U$,7,6)
250 INPUT @3:U$
260 U$=SEG(U$,6,7)
270 T#=T$&U$
280 T(N)=VAL(T$)
290 NEXT N
300 OFF SRQ
310 PRINT 'PRS CR WEN RDY TO CK INPUT'
320 INPUT Z$
330 FOR N=4 TO M STEP 4
340 PRINT T(N-3),T(N-2),T(N-1),T(N)
350 NEXT N
360 PRINT 'ENTER 1(REDISPLAY) OR 2(CONTINUE) OR 3(ABORT)'
370 INPUT Z$
380 GO TO VAL(Z$) OF 310,410,390
390 PRINT 'RUN ABORTED'
400 END
410 PRINT 'PREPARE TO STORE DATA ON INTERNAL TAPE. ENTER FILE NO.'
420 INPUT Y
430 PRINT 'WILL STORE IN FILE ';Y;'. ENTER + WEN RDY'
440 INPUT Z$
450 IF Z$='+' THEN 490
460 LIST 410
470 PRINT 'RUN ABORTED'
480 STOP
490 FIND Y
500 MARK 1,10*(M+1)
510 FIND Y
515 WRITE M
520 FOR N=1 TO M
530 WRITE T(N)
540 NEXT N
550 PRINT 'FILE WRITTEN'
560 END
1000 PAGE
1005 PRINT '          REFRACTION DROPSONDE DATA ANALYZER -- NADC AVTD'
1010 PRINT

```

Figure D-1. Listing for First File of Baroswitch  
Dropsonde Program (Page 1 of 4)



```

1020 PRINT 'ENTER PROG SELECTION 1 OR 2: 1-CAL&ACQ 2-ANALYSIS -- ';
1030 INPUT Z
1040 GO TO Z OF 2000,3000
2000 INIT
2010 PRINT ' ', 'CALIBRATION AND DATA ACQUISITION'
2020 PRINT
2030 PRINT
2050 PRINT 'ENTER DROP DATE AND NUMBER (YYMMDD NN) -- ';
2060 INPUT D,N$
2070 PRINT 'ENTER ZULU LAUNCH TIME (HHMMSS) -- ';
2080 INPUT T$
2090 PRINT 'ENTER ZULU SPLASH TIME (HHMMSS) -- ';
2100 INPUT U$
2110 PRI 'ENTER PRESSURE ALT AT LAUNCH & PRES AT SURFACE (KFT,MB) -- ';
2120 INPUT P1,P2
2130 PRINT 'ENTER SONDE SERIAL NO. (NNNNNN) -- ';
2140 INPUT S$
2150 PRINT 'THERM LOCKIN: ENTER KOHMS AND DEG C (RR.RRR ,TT.T) -- ';
2160 INPUT R3,T3
2170 PRINT 'ENTER HYGR LOCKIN RES IN KOHMS (RR.RRR) -- ';
2180 INPUT R4
2190 PRINT 'ENTER BAROSWITCH SERIAL NUMBER (NNNNNNN) -- ';
2200 INPUT M$
2210 PRINT 'ENTER OPERATOR-DATE CODE (ABCYYMMDD) -- ';
2220 INPUT O$
2230 PRI 'PREPARE FOR PAPER TAPE ENTRY: LOAD TAPE WITH CENTER OF START'
2240 PRINT 'BLOCK AT READ HEAD; PRESS CR WHEN READY'
2250 INPUT Z$
2260 DIM B$(1450)
2270 B$=' '
2280 FOR A1=1 TO 1410
2290 RBYTE A
2300 A=255-A
2310 P9=A
2315 GO TO 2330
2320 GOSUB 2790
2330 IF A>127 THEN 2390
2340 IF A=10 THEN 2290
2350 A$=CHR(A)
2360 B$=B$&A$
2370 NEXT A1
2380 GO TO 2410
2390 A=A-128
2400 GO TO 2340
2410 PRINT 'READER SHOULD STOP NEAR CENTER OF END BLOCK.'
2420 PRINT ' ', ' ', ' ', 'PRESS CR WHEN READY TO CONTINUE.'
2430 INPUT Z$
2432 PRINT 'IF WANT COPY OF THIS PAGE, ENTER + (IF NOT, ENTER -) -- ';
2434 INPUT Z$
2436 IF Z$<>'+' THEN 2440
2438 COPY

```

Figure D-1. Listing for First File of Baroswitch  
Dropsonde Program (Page 2 of 4)



```

2440 PAGE
2450 PRI 'DATE(YYMMDD): ;D;' DROP NO. ;N;' SONDE SER. NO. ;S;
2470 PRINT
2480 PRI 'THERM LOCK-IN: ;R3;' KOHMS AT ;T3;' DEG C', ' HYGR: ;R4;'K'
2490 PRINT
2500 PRINT ' ', 'LAUNCH', 'SPLASH'
2510 PRINT 'TIME (HHMMSS)', T$, U$
2520 PRINT 'PRES. (KFT,MB)', P1, P2
2530 PRINT
2540 PRINT 'BAROSWITCH ;M;' CALIBRATION DATA FROM PAPER TAPE'
2550 PRINT B$;
2560 PRINT ' ', 0$
2580 PRINT 'CK BARO SER NO. IN FIRST LINE OF DATA.'
2590 PRINT 'ENTER 1-TAPE REENTRY OR 2-COPY OR 3-CONTINUE -- ';
2610 INPUT S
2620 GO TO S OF 2230,2630,2640
2630 COPY
2640 PAGE
2650 PRINT 'TAKE READER OFF GPIB & PUT OTHER UNITS ON GPIB'
2660 PRI 'PREPARE TO STORE CAL DATA: NOTE CASS NO. & LOAD CASS IN 4051'
2670 PRINT 'ENTER CASSETTE NO. AND ADDRESS OF CASSETTE UNIT (NN) -- ';
2680 INPUT X
2690 TLIST
2700 PRINT 'ENTER FILE NO. FOR STORING CAL DATA (FF) -- ';
2710 INPUT Z1
2720 FIND Z1
2730 MARK 1,3000
2740 FIND Z1
2750 PRINT @33:D,N$,T$,U$,P1,P2,S$,T3,R3,R4,M$,B$,0$
2760 PRINT 'CAL DATA STORED IN FILE ;Z1;' ON CASSETTE ;X;' ;0$
2761 PRINT 'IF WANT TO WRITE ANOTHER CAL DATA FILE, ENTER + (- IF NOT)'
2762 INPUT Z$
2763 IF Z$='+' THEN 2660
2765 GO TO 110
2770 STOP
2780 REM: WRITTEN 770302; DEBUGGED 770303. MCW
2790 REM: SUBRT FOR CK OF P9 EVEN PARITY
2800 P8=128
2810 P7=0
2820 FOR P6=1 TO 8
2830 IF P9<P8 THEN 2860
2840 P9=P9-P8
2850 P7=P7+1
2860 P8=P8/2
2870 NEXT P6
2880 GO TO P7 OF 2890,2910,2890,2910,2890,2910,2890,2910
2890 PRINT 'P9 FAILED PARITY CK'
2900 STOP
2910 RETURN
2920 REM:DEBUGGED 770502 MCW
2990 STOP

```

Figure D-1. Listing for First File of Baroswitch  
Dropsonde Program (Page 3 of 4)

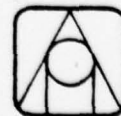

```
3000 REM:DATA ANALYSIS STARTS HERE
3010 DELETE 100,2990
3020 PRINT "WILL READ DATA ANALYSIS PROG FROM INTERNAL CASSETTE FILE 2"
3030 PRINT "  ENTER R WEN RDY  --  ";
3040 INPUT S$
3050 IF S$="R" THEN 3090
3060 LIST 3020
3070 PRINT "RUN ABORTED"
3080 STOP
3090 FIND 2
3100 APPEND 3110
3105 REM:FILED IN CASS 5, FILE 1. 770621 MCW 770629 MCW
3110 REM:DATA ANALYSIS PROG WILL BE APPENDED HERE
```

Figure D-1. Listing for First File of Baroswitch  
Dropsonde Program (Page 4 of 4)



```

3110 REM:THIS PROGRAM (FROM FILE 2) ASSIGNS FILE NOS. TO BE PROCESSED
3112 DELETE 2991,3109
3114 PRI 'LOAD ''SAFE'' DATA CASSETTE INTO CONSOLE. ENTER FILE NOS. OF'
3116 PRINT 'CALIBRATION AND DATA FILES TO BE PROCESSED (CC 00) -- ';
3118 INPUT Z9,Z8
3120 REM:READ CAL FILE, CHECK SUM OF PRESSURES, BUILD PRESSURE TABLE
3122 DELETE Q
3124 DIM Q(184)
3126 Q(183)=0
3128 FIND Z9
3130 INPUT @33:D0,N0,T1,T2,P1,P2,S0,T3,R3,R4,B0
3132 INPUT @33:Q1,Q2,Q3,Q4,Q5,Q6
3134 IF Q1=99999 AND Q5=0 THEN 3142
3136 PRINT 'BAROSWITCH TAPE HEADER TEST FAILED (SEE LINE BELOW)'
3138 LIST 3134
3140 STOP
3142 PRINT 'BAROSW TAPE HDR: ';Q1;Q2;Q3;Q4;Q5;Q6;' (CHECK SER. NO.)'
3144 PRINT 'ENTER + IF OK & RDY TO PROCEED -- ';
3146 INPUT S#
3148 IF S#='+' THEN 3156
3150 LIST 3144
3152 PRINT 'PROGRAMMED STOP'
3154 STOP
3156 FOR I=0 TO 170 STEP 10
3158 IF I=0 THEN 3164
3160 INPUT @33:Q(184),Q0,Q1,Q2,Q3,Q4,Q5,Q6,Q7,Q8,Q9
3162 GO TO 3168
3164 INPUT @33:Q(184),Q1,Q2,Q3,Q4,Q5,Q6,Q7,Q8,Q9
3166 Q0=0
3168 IF Q(184)=I THEN 3178
3170 PRINT 'FAILED BARO CONTACT NO. TEST WITH I=';I;' (SEE TEST BELOW)'
3172 LIST 3160,3168
3174 PRINT 'PROGRAMMED STOP'
3176 STOP
3178 IF I=0 THEN 3182
3180 Q(I)=Q0
3182 Q(I+1)=Q1
3184 Q(I+2)=Q2
3186 Q(I+3)=Q3
3188 Q(I+4)=Q4
3190 Q(I+5)=Q5
3192 Q(I+6)=Q6
3194 Q(I+7)=Q7
3196 Q(I+8)=Q8
3198 Q(I+9)=Q9
3200 PRINT USING 3202:I,Q0,Q1,Q2,Q3,Q4,Q5,Q6,Q7,Q8,Q9
3202 IMAGE 3D,5D.D,5D.D,5D.D,5D.D,5D.D,5D.D,5D.D,5D.D,5D.D,5D.D,4D.D
3204 Q(183)=Q(183)+Q0+Q1+Q2+Q3+Q4+Q5+Q6+Q7+Q8+Q9
3206 NEXT I
3208 INPUT @33:Q(184),Q(180),Q(181),Q(182)
3210 IF Q(184)=180 THEN 3218

```

Figure D-2. Listing for Second File of Baroswitch  
Dropsonde Program (Page 1 of 9)



```

3212 LIST 3210,3214
3214 STOP
3216 INPUT @33:Q(180),Q(181),Q(182)
3218 IF Q(180)=0 AND Q(181)=0 THEN 3226
3220 LIST 3218,3224
3222 PRINT 'PROGRAMMED STOP'
3224 STOP
3226 PRINT USING 3228:Q(180),Q(181),Q(182)
3228 IMAGE'180',5D.D,5D.D,5D.D
3230 Q(183)=Q(183)+Q(180)+Q(181)
3232 INPUT @33:0$
3234 N=0
3236 N=N+1
3238 Z$=SEG(0$,N,1)
3240 IF Z$>' ' AND Z$<='*' THEN 3244
3242 GO TO 3236
3244 0$=SEG(0$,N,9)
3246 PRINT 'CAL FILE OPR-DATE CODE = ':0$
3248 PRINT ' ',',',',','PRESSURE SUM = ':Q(183);
3250 IF Q(183)-Q(182)>9999.9 THEN 3258
3252 PRINT ' (FAILED CK SUM TEST)'
3254 LIST 3250,3256
3256 STOP
3258 PRINT ' (CK SUM OK)'
3260 PRINT 'ENTER TIME INTERVAL (SEC.) FROM LAUNCH TO XMITTER ON -- ':
3262 INPUT T0
3264 PRI 'FOR AUTOCOPY&PAGE, ENTER 1; AUTOPAGE ONLY, 2; NEITHER, 3 -- ':
3266 INPUT S9
3268 GO TO S9 OF 3274,3280,3286
3270 END
3272 REM:WRITTEN770415,LOADED770504,DEBUGGED770505,INTEGRATED770705 MCW
3274 REM:START HERE FOR AUTOCOPY&PAGE
3276 PRINT @32,26:3
3278 GO TO 3290
3280 REM:START HERE FOR AUTOPAGE
3282 PRINT @32,26:2
3284 GO TO 3290
3286 REM:START HERE FOR MANUAL COPY&PAGE
3288 PRINT @32,26:0
3290 REM:READ & UNPACK DATA FROM FILE
3292 DIM A(4),B(4),C(4),D(4)
3294 RESTORE 3298
3296 READ @34:T9,T8,T7,T6,A,B,C,D
3298 DATA 0,0,0,1,0,0,0,0,0,0,0,0,0,0,0,0,2.0E-5,3.0E-6,3.0E-4,1.5E-6
3300 REM:INITIALIZE FOR GETTING SIG PER RATIOS USING SIG LEV SUBRT
3302 DIM P(3,400),S(3,8)
3304 FOR I9=1 TO 3
3306 FOR I8=1 TO 400
3308 P(I9,I8)=0
3310 NEXT I8
3312 NEXT I9

```

Figure D-2. Listing for Second File of Baroswitch  
Dropsonde Program (Page 2 of 9)



```

3314 RESTORE 3318
3316 READ @34:P(1,400),P(2,400),P(3,400),S
3318 DATA 0,0,0,7.0E-4,0,-9.9E+99,9.9E+99,0,0,0,0,1.0E-3,0,-9.9E+99
3320 DATA 9.9E+99,0,0,0,0,8.0E-4,0,-9.9E+99,9.9E+99,0,0,0,0
3322 PRINT 'SELECT DATA SOURCE: 1=PACKED FILE, 2=REDUCED FILE -- ':
3324 INPUT S9
3326 GO TO S9 OF 3346,3330
3328 STOP
3330 PRINT 'PUT''SAFE''CASS (FILE 23=P ARRAY) IN 4051. ENT R UN RDY - ':
3332 INPUT S#
3334 IF S#="R" THEN 3338
3336 GO TO 3330
3338 DIM P(3,400)
3340 FIND Z3
3342 READ @33:P
3343 PRINT 'CK & CORRECT P(M,N), THEN ''RUN(LINE # AFTER STOP)''.'
3344 STOP
3345 GO TO 3382
3346 FIND Z8
3348 READ @33:Z7
3350 Z6=0
3352 Z6=Z6+1
3354 READ @33:Z0
3356 GO TO 3360
3358 PRINT @41:Z6,Z0;
3360 REM:UNPACK FIRST HALF Z0 TO GET PERIOD Z1
3362 Z1=INT(Z0)/1.0E+8
3364 REM:PROCESS UNPACKED VALUE
3366 GOSUB 3384
3368 REM:UNPACK & PROCESS SECOND PERIOD
3370 Z1=(Z0-INT(Z0))/100
3372 GOSUB 3384
3374 REM:WAS THIS WORD THE LAST IN FILE?
3376 IF Z6=Z7 THEN 3380
3378 GO TO 3352
3380 PRINT 'LAST ENTRY HAS BEEN READ FROM PACKED DATA FILE'
3382 GO TO 3770
3384 REM:TESTING & MAINTAINING SYNC
3385 REM:T9 SAMPS ENTERED STACK SINCE LAUNCH. T8=LAST REF TAG
3386 IF T9=0 THEN 3512
3388 GO TO T6 OF 3396,3406,3406,3466
3390 LIST 3388
3392 PRINT 'T6=';T6
3394 STOP
3396 REM:CYCLE SHIFT
3398 A0=A(4)
3400 A=B
3402 B=C
3404 T9=T9+4
3406 IF Z1>1/1500 AND Z1<1/240 THEN 3440
3408 IF Z1=>1/1800 AND Z1<=1/1500 THEN 3416

```

Figure D-2. Listing for Second File of Baroswitch  
Dropsonde Program (Page 3 of 9)



```

3410 REM:Z1 NOT DATA AND NOT REF. APPLY NON-VALID TAG (.1)
3412 Z1=0.1+Z1
3414 GO TO 3440
3416 GO TO T6 OF 3420,3426,3432,3418
3418 STOP
3420 C(1)=0.00416666
3422 T6=T6+1
3424 T7=T7+1
3426 C(2)=0.00416666
3428 T6=T6+1
3430 T7=T7+1
3432 C(3)=0.00416666
3434 T6=T6+1
3436 T7=T7+1
3438 GO TO 3384
3440 GO TO T6 OF 3448,3454,3460,3466
3442 LIST 3440
3444 PRINT 'T6=';T6
3446 STOP
3448 C(1)=Z1
3450 T6=2
3452 GO TO 3592
3454 C(2)=Z1
3456 T6=3
3458 GO TO 3592
3460 C(3)=Z1
3462 T6=4
3464 GO TO 3592
3466 IF Z1=>1/1800 AND Z1<=1/1500 THEN 3480
3468 REM:REF EXPECTED BUT MISSING; ADD SYNC-LOSS TAG .99 TO DDR SAMPS
3476 C(4)=Z1
3478 C=0.99+C
3479 GO TO 3484
3482 T8=T9+T7
3483 C(4)=Z1
3484 T6=1
3485 PRINT 'T9,T7,T8=',T9,T7,T8
3486 PRINT 'B=';T9+T7-7+B(1),T9+T7-6+B(2),T9+T7-5+B(3),T9+T7-4+B(4)
3488 REM:RESTORE CYCLE IN ARRAY B, IF NEEDED
3490 GOSUB 3594
3492 REM:CALCULATE PERIOD RATIOS IN ARRAY A
3494 GOSUB 3664
3496 PRINT @41:A(1),A(2),A(3),T9+T7-8+A(4)
3498 REM:SCAN ARRAY A & DETECT SIG RATIOS
3500 FOR N8=1 TO 3
3502 P9=N8+A(N8)
3504 N9=T9+T7-12+N8
3506 GOSUB 3692
3508 NEXT N8
3510 GO TO 3592
3512 REM:LOOKING FOR FIRST SYNCHRONIZED CYCLE

```

Figure D-2. Listing for Second File of Baroswitch  
Dropsonde Program (Page 4 of 9)



```

3514 GO TO T6 OF 3516,3522,3522,3522,3532
3516 REM:IS Z1 A REF SIGNAL?
3518 IF Z1>=1/1800 AND Z1<=1/1500 THEN 3536
3520 GO TO 3588
3522 REM:IS Z1 A DATA SIGNAL?
3524 IF Z1>=1/1500 AND Z1<=1/240 THEN 3542
3526 PRINT 'FALSE START. T6=';T6
3528 T6=1
3530 GO TO 3512
3532 IF Z1>=1/1800 AND Z1<=1/1500 THEN 3566
3534 GO TO 3526
3536 T6=2
3538 B(4)=Z1
3540 GO TO 3588
3542 GO TO T6 OF 3544,3548,3554,3560,3544
3544 LIST 3542
3546 STOP
3548 T6=3
3550 C(1)=Z1
3552 GO TO 3588
3554 T6=4
3556 C(2)=Z1
3558 GO TO 3588
3560 T6=5
3562 C(3)=Z1
3564 GO TO 3588
3566 REM:T9 IS NO. OF SAMPS TO 'ENTER' STACK SINCE LAUNCH
3568 T9=T0*10+8
3569 T8=T9
3570 T6=1
3572 C(4)=Z1
3574 PRINT Z6+T7+Z1
3576 PRINT
3578 PRINT 'LAST 5 SAMPS ARE FIRST CYCLE PASSING RDDDR RANGE TEST'
3580 PRINT
3582 PRINT 'REF STARTING 1ST SYNC CYCLE (TIME-TAG + PER): ';T9-4+8(4)
3584 PRINT 'FOLLOWING SAMPS ARE OUTPUT FROM SYNC TEST & MAINTENANCE'
3586 GO TO 3592
3588 REM:PRINT FILE ENTRY NO.(Z6) & PERIOD
3590 PRINT Z6+T7+Z1;'      ';
3592 RETURN
3594 REM:VALIDATE DATA IN ARRAY C USING LIMITS IN D
3596 FOR N9=1 TO 4
3598 GO TO N9 OF 3606,3600,3604,3606
3600 D(2)=400*D(2)
3602 GO TO 3606
3604 D(2)=D(2)/400
3606 IF ABS(A(N9)-C(N9))<D(N9) OR ABS(B(N9)-C(N9))<D(N9) THEN 3610
3608 PRINT 'C(';N9;') FAILS VAL TEST.TIME-TAGGED PER.=';T9+T7-4+N9+C(N9)
3610 NEXT N9
3612 REM:RESTORE DATA IN ARRAY B

```

Figure D-2. Listing for Second File of Baroswitch  
Dropsonde Program (Page 5 of 9)



```

3614 N8=0
3616 FOR N9=1 TO 4
3618 IF ABS(A(N9)-B(N9))<D(N9) THEN 3642
3620 REM:B(N9) NOT OK. CAN C(N9) BE USED TO RESTORE?
3622 IF ABS(A(N9)-C(N9))<D(N9) THEN 3628
3624 REM:C(N9) NOT OK FOR RESTORATION
3626 GO TO 3642
3628 REM:RESTORE B(N9)
3630 PRINT
3632 PRINT "RESTORED PACK-WORD";Z6-1; FROM ";T9+T7-8+N9+B(N9);" TO ";
3634 B(N9)=(A(N9)+C(N9))/2
3636 PRINT T9+T7-8+N9+B(N9)
3638 PRINT
3640 GO TO 3646
3642 REM:NO RESTORATION. INCREMENT COUNT OF NON-RESTORED SAMPS (N8)
3644 N8=N8+1
3646 NEXT N9
3648 IF N8<4 THEN 3652
3650 GO TO 3660
3652 PRINT
3654 PRINT "RESTORED CYCLE FOLLOWS:"
3656 PRINT T9+T7-7+B(1),T9+T7-6+B(2),T9+T7-5+B(3),T9+T7-4+B(4)
3658 PRINT
3660 N8=0
3662 RETURN
3664 REM:CALCULATE PERIOD RATIOS IN ARRAY A
3666 IF A(1)=0 AND A(2)=0 AND A(3)=0 THEN 3690
3668 IF A0=>1/1800 AND A0<=1/1500 AND ABS(A0-A(4))<D(4) THEN 3676
3669 C(1)=0.999
3670 C(2)=0.999
3671 C(3)=0.999
3672 PRINT @41:"TAGS ";T9+T7-13;"&"T9+T7-9;" FAIL REF COMP;ADD .999"
3674 GO TO 3690
3676 FOR N9=1 TO 3
3678 IF A(N9)<0.00416666 THEN 3686
3680 LIST 3678
3682 PRINT "PROGRAMMED STOP"
3684 STOP
3686 A(N9)=(A0*(4-N9)+A(4)*N9)/(4*A(N9))
3688 NEXT N9
3690 RETURN
3692 REM:FIND SIGNIFICANT PERIOD RATIOS
3694 REM:INPUT IS ID-TAGGED PERIOD RATIO P9 AT TIME N9 (SAMPLE NO.)
3696 REM:INPUT TOLERANCES ARE S(M,1)
3698 REM:OUTPUTS ARE TIME-TAGGED SIGNIFICANT LEVELS P(M,N)
3700 REM:P(M,400) IS NO. OF SIGNIF LEVS STORED
3702 M=INT(P9)
3704 REM:CALCULATE NEW SLOPE S(M,5)
3706 S(M,5)=(P9-INT(P9)-(S(M,2)-INT(S(M,2))))/(N9-INT(S(M,2)))
3708 REM:TEST NEW SLOPE
3710 IF S(M,5)>=S(M,3) AND S(M,5)<=S(M,4) THEN 3726

```

Figure D-2. Listing for Second File of Baroswitch  
Dropsonde Program (Page 6 of 9)





```

3890 E9=E7
3900 GO TO 3920
3910 E9=E6
3920 REM:FIND FIRST RATIO IN EXPECTED RANGE
3930 N=1
3940 E3=P(M,N)
3950 IF E3-INT(E3)>0.1 AND E3-INT(E3)<0.95 THEN 3980
3960 N=N+1
3970 GO TO 3940
3980 E3=N
3990 N=N+1
4000 E4=P(M,N)
4010 E5=(E4-INT(E4))/(P(M,E3)-INT(P(M,E3)))
4020 E5=E5^(10/(INT(E4)-INT(P(M,E3))))
4030 IF E5<E9 AND E5>1/E9 THEN 4130
4040 REM:RATIO CHANGE IS EXCESSIVE. FIND NEXT RATIO WITHIN CHANGE LIMIT
4041 PRINT ' ',E5=';E5
4042 S9=INT(P(1,P(1,400)))
4043 Z9=INT(P(3,P(3,400)))
4044 IF M=3 AND INT(E4)>S9 AND Z9-INT(E4)<20 THEN 4048
4047 GO TO 4050
4048 PRINT 'BAD HUM PAST TEMP END & WITHIN 2 SEC OF HUM END'
4049 GO TO 4070
4050 IF N<P(M,400) THEN 4300
4060 PRINT 'REACHED END OF FILE P(';M;'N). LAST OK SAMP=';P(M,E3)
4070 PRINT 'FOLLOWING SAMPs BEING DELETED:'
4080 N=E3
4085 N=N+1
4090 PRINT ' ',P(M,N)
4100 P(M,N)=0
4110 IF N=P(M,400) THEN 4122
4120 GO TO 4085
4122 P(M,400)=E3
4124 GO TO 4300
4130 REM:RATIO CHANGE IS WITHIN EXPECTED LIMITS
4140 IF E3=N-1 THEN 4290
4150 IF INT(E4)-INT(P(M,E3))<21 THEN 4190
4160 LIST 4150
4170 PRINT 'DATA GAP EXCEEDS 2 SEC. SHOULD IT BE RESTORED?'
4180 STOP
4190 PRINT 'DATA GAP <2 SEC BEING RESTORED'
4200 PRINT 'PRE-GAP VALUE =';P(M,E3)
4210 E3=E3+1
4220 PRINT 'P(';M;'',';E3;') CHANGED FROM ';P(M,E3);' TO '
4230 E2=E5^(((INT(P(M,E3))-INT(P(M,E3-1)))/10)
4240 P(M,E3)=INT(P(M,E3))+(P(M,E3-1)-INT(P(M,E3-1)))*E2
4250 PRINT P(M,E3)
4260 IF E3=N-1 THEN 4280
4270 GO TO 4210
4280 PRINT 'POST-GAP RATIO = ';P(M,N)
4290 E3=N

```

Figure D-2. Listing for Second File of Baroswitch  
Dropsonde Program (Page 8 of 9)



```
4300 IF N=>P(M,400) THEN 4320
4310 GO TO 3990
4320 PRINT ' ', 'END M=';M
4321 NEXT M
4322 PRINT 'TO LIST PER. RATIOS AFTER GAP PROC'G, ENTR '**+' -- ';
4324 INPUT S$
4326 IF S$<>'+' THEN 4330
4328 PRINT @41:'PERIOD RATIOS AFTER GAP PROCESSING'
4329 PRINT @41:F
4330 STOP
4340 REM:NOW IMPORT SOFTWARE FOR PROCESSING DATA FROM ARRAY.
4345 PRI 'LOAD ''SAFE'' PROG CASS IN INTERNL UNIT. ENTR R WEN RDY -- ';
4350 INPUT S$
4355 IF S$='R' THEN 4365
4360 GO TO 4345
4365 FIND 3
4370 DELETE 100,4360
4375 APPEND 4750
4750 REM:PROG FILE 3 GETS APPENDED HERE
```

Figure D-2. Listing for Second File of Baroswitch  
Dropsonde Program (Page 9 of 9)

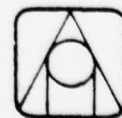

```

4750 REM:THIS PROG FROM FILE 3 APPENDS TO END OF PROG FROM FILE 2
4755 REM:ANALYZE DATA FROM INTERNAL FILE
4760 DELETE 100,4749
4765 REM:CALCULATE MB PRESSURE (Q9) AT LAUNCH ALT
4770 REM:INPUTS- PRESSURE ALT P1 (KFT), SURFACE PRESSURE P2 (MB)
4775 Q9=(P2*0.190263-0.0256553*P1)*5.255883
4780 REM:Q9+10*=PRESS AT 1ST OBSERVABLE CON BK (~3 SEC AFTER LAUNCH)
4785 REM:FETCH FIRST BARO BK NO. Q0 THAT WILL OCCUR AFTER Q9+5
4790 Q0=100
4795 IF Q(Q0)>Q9+5 THEN 4810
4800 Q0=Q0-1
4805 GO TO 4795
4810 PRINT 'FIRST CONTACT NO. EXPECTED IS APPROX ';Q0
4815 Q8=Q0
4820 REM:BREAK DETECTION & CONTACT NO. ASSIGNMENT
4825 REM:Q8=NEXT EXPECTED CON NO.; Q7=THIS CON TYP; Q6= LAST CON TYP
4830 REM:Q5=CON START TIME; Q4=CON STOP; Q3= INS START; Q2= INS STOP
4835 REM:Q1=CON NO. ERROR; Q0=EXPECTED INITIAL CON; F9=PREP FILE POINTER
4836 REM:F8=LAST SIGNIF RATIO
4840 Q8=Q0
4845 DIM F(100)
4850 RESTORE 4860
4855 READ @34:N,Q7,Q6,Q5,Q4,Q3,Q2,F9,F8
4860 DATA 1,9,9,0,0,0,0,0,0
4865 IF INT(P(2,N))-INT(F(F9))>200 THEN 4868
4866 GO TO 4876
4868 PRINT 'CON BK OVERDUE. TIME-TAG=';INT(P(2,N));
4869 Q8=100*(F(F9)-INT(F(F9)))+INT((INT(P(2,N))-INT(F(F9)))/110+0.5)
4870 PRINT '. NOW EXPECTING BK #';Q8
4876 IF P(2,N)-INT(P(2,N))<1.0E-4 THEN 5175
4877 IF ABS(P(2,N)-INT(P(2,N))-(F8-INT(F8)))=>0.01 THEN 5165
4878 GO TO (P(2,N)-INT(P(2,N))-0.52)/0.14 OF 4885,4885,4900
4880 IF P(2,N)-INT(P(2,N))<0.59 THEN 5065
4882 LIST 4880
4883 STOP
4885 REM:CONTACT IS 5- OR 15-TYPE
4890 Q7=5
4895 GO TO 4910
4900 REM:CONTACT IS 1-TYPE
4905 Q7=1
4910 REM:CONTACT MONITOR & MAKE DETECTOR
4920 IF Q5>0 THEN 4930
4925 Q5=INT(F8)
4930 Q4=INT(P(2,N))
4931 IF Q4-Q5<8 THEN 5165
4932 IF Q3=0 THEN 5165
4935 IF Q2-Q3<120 AND Q5-Q2<21 THEN 4970
4940 LIST 4935
4960 PRI 'WILL ASSIGN TENT CON NO. ';Q8;' IF TEST FAILURE IS OVERRIDDEN'
4965 STOP
4970 REM:DECLARE '**MAKE**' HERE (IF WANTED) & CLR INS REGS

```

Figure D-3. Listing for Third File of Baroswitch  
Dropsonde Program (Page 1 of 8)



```

4976 PRINT ' ', ' ', 'Q3=';Q3,'Q2=';Q2
4980 IF Q7<>5 THEN 5050
4985 REM:THIS CON IS 5-TYPE. IS 5-TYPE EXPECTED?
4990 Q1=5*(Q8/5-INT(Q8/5))
4995 IF Q1=0 THEN 5050
5000 GO TO Q1 OF 5035,5035,5015,5025
5005 LIST 5000
5010 STOP
5015 Q1=-2
5020 GO TO 5035
5025 Q1=-1
5035 PRINT 'CON NO. EXPECTED= ';Q8;', BUT 5- OR 15-TYPE WAS DETECTED.'
5040 GOSUB 5200
5050 Q3=0
5055 Q2=0
5060 GO TO 5165
5065 REM:INSULATOR MONITOR & BREAK DETECTOR
5070 Q7=0
5080 IF Q3>0 THEN 5085
5081 REM:SET INS START TIME
5082 Q3=INT(F8)
5085 Q2=INT(P(2,N))
5090 IF Q2-Q3<8 THEN 5165
5091 IF Q5=0 THEN 5165
5095 IF Q4-Q5<80 AND Q3-Q4<21 THEN 5110
5100 LIST 5095
5105 STOP
5110 REM:DECLARE BREAK & CLR CON REGS
5116 PRINT 'Q5=';Q5,'Q4=';Q4
5120 PRINT 'BARO-BREAK: ';Q4+2+Q8/100
5125 F9=F9+1
5130 F(F9)=Q4+2+Q8/100
5135 Q8=Q8-1
5140 Q5=0
5145 Q4=0
5150 GO TO 5165
5165 REM:SET LAST TYPE REG & READ NEXT SIGNIF RATIO
5166 F8=P(2,N)
5170 Q6=Q7
5175 N=N+1
5180 IF N>P(2,400) THEN 5190
5185 GO TO 4865
5190 PRINT 'END OF BARO PERIOD RATIO PROCESSING'
5191 F(F9+1)=INT(F(F9))+2 MAX Q4+2
5192 F(F9+1)=F(F9) MAX Q2+2
5193 F9=F9+1
5194 GO TO 5300
5200 REM:CORRECTION OF CON NO.
5205 IF Q0-Q8<5 THEN 5235
5210 REM:CON NO. CORRECTION NEEDED. GET PRINT OF CON NO. ASSIGNMENTS.
5215 REM:MANUALLY ANALYZE & CORRECT. NOTE IF CAN AUTOCORRECT; PROCEED

```

Figure D-3. Listing for Third File of Baroswitch  
Dropsonde Program (Page 2 of 8)



```

5220 LIST 5205,5215
5225 STOP
5230 GO TO 5270
5235 PRI 'THIS IS 1ST 5-/15-TYPE CON; CORRECT Q8 & EARLIER CONS BY -Q1'
5240 Q8=Q8-Q1
5245 N9=0
5250 IF F(F9+N9)-INT(F(F9+N9))<=Q0 THEN 5255
5251 Q0=Q0-Q1
5252 GO TO 5270
5255 F(F9-N9)=F(F9-N9)-Q1/100
5260 N9=N9+1
5265 GO TO 5250
5270 RETURN
5300 REM: CONVERT CON NOS. TO MB IN F ARRAY
5310 FOR N=1 TO F9-1
5320 F(N)=INT(F(N))+Q(100*(F(N)-INT(F(N))))/10000
5330 NEXT N
5335 F(100)=F9-1
5340 FOR N=F9 TO 99
5345 F(N)=0
5350 NEXT N
5360 PRINT 'OPR-ENTERED ESTIMATE OF SURFACE PRESSURE=';P2
5365 PRINT 'OK FOLLOWING CON BK TIMES & PRESSURES (SEE IF LOOK OK)''
5400 REM: LIST PRESSURE-TIME PROFILE
5410 PRINT
5420 PRINT
5430 PRINT 'F(N), TAG.P                TIME (APPROX. SEC)    PRESSURE (MB)''
5440 FOR N=1 TO F9-1
5450 PRINT F(N), ' ', INT(F(N))/10, (F(N)-INT(F(N)))*10000
5460 NEXT N
5470 PRINT
5480 PRINT ' ', 'END OF DATA'
5485 PRINT 'PRESSURES F(N) LIST LOOK OK? IF NOT, CHANGE BEFORE TEMP RUN'
5490 STOP
5500 REM: CALCULATE TEMPS. T9=RES RATIO, T8=THIS APPARENT TEMP, T7=LAST
5502 REM: APP TEMP, T6=THIS TIME, T5=LAST TIME
5503 PRINT 'STARTING TEMP CALCS'
5506 REM: J0 & J1 ARE LAG COMP FACTORS FOR TEMP & HUM RANGING 0 TO 1
5508 RESTORE 5509
5509 DATA -99,0,0
5510 READ @34:T9,J0,J1
5511 PRINT 'COMPS SET AT T: ';J0; ' & H: ';J1; ' WANT CHANGE? (1+/2-) - ';
5513 INPUT Z9
5514 GO TO Z9 OF 5516,5520
5515 GO TO 5511
5516 PRINT 'ENTR COMP SETTINGS IN RANGE 0-1 (NONE-FULL) (T.TT H.HH)- ';
5517 INPUT J0,J1
5518 GO TO 5511
5520 PRINT @41: '      LAG-COMP LEVELS ARE SET TO T: ';J0; ' & H: ';J1
5522 FOR N=1 TO P(1,400)
5523 T9=P(1,N)-INT(P(1,N))

```

Figure D-3. Listing for Third File of Baroswitch  
Dropsonde Program (Page 3 of 8)



```

5525 T6=INT(P(1,N))
5530 IF T9>0.1 THEN 5560
5540 LIST 5530
5550 GO TO 5640
5560 REM:CALCULATE RES RATIO
5565 T9=(52.718/T9-47.718)/R3
5570 REM:CALCULATE APPARENT TEMP
5575 T8=65.3/(1-SQR(1-0.0480921*LOG(T9/3.3785E-4)))-273.16
5580 P(1,N)=INT(P(1,N))+T8/1000
5584 GO TO 5590
5585 PRINT 'TIME-TAGGED APPARENT TEMP(MILLIDEG C)=';P(1,N)
5590 IF T7>-70 THEN 5620
5600 LIST 5590
5610 STOP
5620 REM:LAG-COMP OF TEMP; JO=COMP-LEVEL SETTING (0-1: NONE-FULL)
5630 Z9=INT((T6+T5)/2+0.5)
5632 P(1,N-1)=Z9+0.1+1.0E-3*((T8+T7)/2+(T8-T7)/(T6-T5)*20*JO)
5634 GO TO 5640
5635 PRINT 'TAG:';INT(P(1,N)), 'LC TEMP:';(P(1,N)-INT(P(1,N))-0.1)*1000
5637 PRINT 1000*(P(1,N-1)-INT(P(1,N-1))-0.1)
5640 T7=T8
5650 T5=T6
5670 NEXT N
5672 P(1,P(1,400))=0
5674 P(1,400)=P(1,400)-1
5680 PRINT 'END'
5690 STOP
6000 REM:OVERLAY P(3,N) ARRAY WITH COMP HUM VALUES.
6020 REM:C9=LAST APP HUM, C8=LAST APP HUM TIME-TAG, C7=MEAN APP HUM
6040 REM:C3=MEAN TAG, C5= APP HUM RATE, C4=THIS APP HUM TIME TAG
6050 PRINT 'STARTING HUM CALCS'
6060 RESTORE 6100
6080 READ @34:C9,D7
6100 DATA 999,1
6160 FOR N=1 TO P(3,400)
6180 REM:CALC HYGR RES RATIO R8
6200 R8=P(3,N)-INT(P(3,N))
6209 PRINT 'PER RATIO = ';R8;
6210 IF R8=0 THEN 6860
6220 R8=52.718/R8-47.718-7.1
6230 R8=250*R8/(250-R8)/R4
6239 PRINT ' RES RATIO=';R8
6240 REM:FETCH CORRESPONDING COMP TEMP T6 FOR APP HUM CALC
6260 C4=INT(P(3,N))
6270 D9=C4
6279 PRINT 'TIME=';C4/10;
6280 GOSUB 7000
6281 PRINT ' TEMP=';D8;
6300 T6=D8
6320 REM:CALC APP HUM
6340 GOSUB 8000

```

Figure D-3. Listing for Third File of Baroswitch  
Dropsonde Program (Page 4 of 8)



```

6359 PRINT "    APP H=";H9
6360 IF C9>101 OR H9=999 THEN 6370
6365 GO TO 6380
6370 IF N<=1 THEN 6800
6375 P(3,N-1)=INT(P(3,N-1))+0.999
6377 GO TO 6800
6380 REM:CAL MEAN AP HUM C7, MEAN-TAG TEMP C6 & HUM RATE C5 FOR HUM SEG
6400 C7=(H9+C9)/2
6420 C3=INT((C4+C8)/2+0.5)
6440 C5=(H9-C9)/(C4-C8)*10
6460 REM:FETCH COMP TEMP C6 FOR TIME-TAG C3
6480 D9=C3
6499 PRINT "TIME=";D9/10;
6500 GOSUB 7000
6501 PRINT "    TEMP=";D8;
6502 IF D8<>999 THEN 6520
6504 IF C3-INT(P(1,P(1,400)))>0 AND C3-INT(P(1,P(1,400)))<=4 THEN 6510
6506 GO TO 6520
6510 PRINT "TAG IS WITHIN 4 SEC OF TEMP END. LAST TEMP WILL BE USED"
6512 D8=C6
6514 PRINT "    TEMP=";D8
6520 C6=D8
6540 GOSUB 9000
6541 PRINT "    ", "COMP H=";G6
6545 IF G6<=100 THEN 6560
6549 LIST 6545
6550 PRINT "COMP HUM CHANGED FROM ";G6;" TO 100; TIME TAG= ";C6
6560 P(3,N-1)=C3+1.0E-3*(G6 MIN 100)
6800 REM:SET-UP FOR PROCESSING NEXT N
6820 C9=H9
6840 C8=C4
6860 NEXT N
6880 P(3,P(3,400))=0
6900 P(3,400)=P(3,400)-1
6920 PRI "COMP HUM VALUES HAVE BEEN STORED IN REDUCED DATA FILE P(3,N)"
6940 PRINT @41:P
6960 GO TO 9100
7000 REM:APPEND TEMP-FETCH HERE
7020 REM:FETCH COMP-TEMP D8 FOR TIMETAG D9 USING POINTER D7
7022 IF INT(P(1,1))<=D9 AND INT(P(1,P(1,400)))=>D9 THEN 7040
7024 PRINT "TIME-TAG D9 (";D9;" ) IS OUTSIDE LIMITS OF REDUCED TEMP DATA"
7026 D8=999
7028 GO TO 7360
7040 IF D7=>1 AND D7<=P(1,400) THEN 7080
7050 IF D7<>0 THEN 7080
7060 D8=999
7070 GO TO 7360
7080 D8=INT(P(1,D7))
7100 IF D8<>D9 THEN 7160
7120 D8=1000*(P(1,D7)-0.1-D8)
7140 GO TO 7360

```

Figure D-3. Listing for Third File of Baroswitch  
Dropsonde Program (Page 5 of 8)



```

7160 IF D8<D9 THEN 7220
7180 D7=D7-1
7200 GO TO 7040
7220 D7=D7+1
7240 D8=INT(P(1,D7))
7260 IF D8=D9 THEN 7120
7280 IF D8>D9 THEN 7320
7300 GO TO 7220
7320 D8=(D9-INT(P(1,D7-1)))/(D8-INT(P(1,D7-1)))
7340 D8=D8*(P(1,D7)-INT(P(1,D7))-(P(1,D7-1)-INT(P(1,D7-1))))
7350 D8=1000*(P(1,D7-1)-INT(P(1,D7-1))-0.1+D8)
7360 RETURN
8000 REM:CALC %RH- INPUT COMP TEMP T6 & HYG RATIO R8; OUTPUT RH ZH9
8001 IF T6<>999 THEN 8005
8002 H9=999
8003 GO TO 8515
8005 DATA 0.52,0.62,0.74,0.82,0.9,1.1,1.3,1.63,2.23
8010 DATA 3.1,4.2,6.5,10.2,17,29,45,45,45,45
8015 DATA 0.55,0.65,0.78,0.85,0.92,1.06,1.23,1.4,1.75
8020 DATA 2.35,3.1,4.1,6,9.8,17,26,44,86,170,250
8025 DATA 0.585,0.695,0.8,0.875,0.94,1.05,1.175,1.32,1.58
8030 DATA 2,2.5,3.25,4.5,7.3,12,18.5,29,60,140,220
8035 DATA 0.61,0.72,0.82,0.89,0.95,1.04,1.15,1.27,1.47
8040 DATA 1.85,2.3,3,4,6.4,10,16,23,40,126,206
8045 H1=0
8050 H2=0
8055 H3=0
8060 H4=0
8065 IF T6=>-40 AND T6<0 THEN 8075
8070 GO TO 8090
8075 RESTORE 8005
8080 H1=999
8085 GOSUB 8290
8090 IF T6=>-40 AND T6<25 THEN 8100
8095 GO TO 8115
8100 RESTORE 8015
8105 H2=999
8110 GOSUB 8290
8115 IF T6>0 AND T6<40 THEN 8125
8120 GO TO 8140
8125 RESTORE 8025
8130 H3=999
8135 GOSUB 8290
8140 IF T6>25 AND T6<=40 THEN 8150
8145 GO TO 8165
8150 RESTORE 8035
8155 H4=999
8160 GOSUB 8290
8165 IF T6<-40 OR T6>40 THEN 8175
8170 GO TO 8190
8175 LIST 8165

```

Figure D-3. Listing for Third File of Baroswitch  
Dropsonde Program (Page 6 of 8)



```

8180 PRINT 'T6= ';T6,' - TILT!!! TEMP EXCEEDS HYG RATIO LIMITS'
8181 PRINT 'WILL SET H9=999 & RETURN'
8182 GO TO 8002
8185 STOP
8190 REM:TEMP INTERPOLATION OF RH BEGINS HERE
8195 IF H1>0 AND H2=0 AND H3=0 AND H4=0 THEN 8455
8200 IF H1=0 AND H2>0 AND H3=0 AND H4=0 THEN 8465
8205 IF H1=0 AND H2=0 AND H3>0 AND H4=0 THEN 8475
8210 IF H1=0 AND H2=0 AND H3=0 AND H4>0 THEN 8485
8215 IF H1>0 AND H2>0 AND H3=0 AND H4=0 THEN 8225
8220 GO TO 8235
8225 H9=H1+(H2-H1)*(T6+40)/40
8230 GO TO 8495
8235 IF H1=0 AND H2>0 AND H3>0 AND H4=0 THEN 8245
8240 GO TO 8255
8245 H9=H2+(H3-H2)*T6/25
8250 GO TO 8495
8255 IF H1=0 AND H2=0 AND H3>0 AND H4>0 THEN 8265
8260 GO TO 8275
8265 H9=H3+(H4-H3)*(T6-25)/15
8270 GO TO 8495
8275 LIST 8255
8280 PRINT 'PROGRAMMED STOP'
8285 STOP
8290 REM:INTERPOLATE RATIO TO GET HUM; PUT HUM IN PLACE OF 999 VALUE
8295 H7=5
8300 READ @34:H8
8305 IF R8=>H8 THEN 8320
8310 H5=9.9
8315 GO TO 8370
8320 H7=H7+5
8325 IF H7<=105 THEN 8345
8330 LIST 8325
8335 PRINT 'HYGR RATIO EXCEEDS LIMITS, (=';R8;')'
8340 GO TO 8002
8345 H6=H8
8350 READ @34:H8
8355 IF R8>H8 THEN 8320
8360 REM:R8 IS IN RANGE OF H6 - H8; WILL INTERPOLATE RATIO TO GET HUM
8365 H5=H7+5*(R8-H6)/(H8-H6)
8370 REM:REPLACE999 WITH H5 THEN RETURN
8375 IF H1=999 AND H2<106 AND H3<106 AND H4<106 THEN 8410
8380 IF H1<106 AND H2=999 AND H3<106 AND H4<106 THEN 8420
8385 IF H1<106 AND H2<106 AND H3=999 AND H4<106 THEN 8430
8390 IF H1<106 AND H2<106 AND H3<106 AND H4=999 THEN 8440
8395 LIST 8390
8400 PRINT 'PROGRAMMED STOP'
8405 STOP
8410 H1=H5
8415 GO TO 8450
8420 H2=H5

```

Figure D-3. Listing for Third File of Baroswitch  
Dropsonde Program (Page 7 of 8)



```

8425 GO TO 8450
8430 H3=H5
8435 GO TO 8450
8440 H4=H5
8445 GO TO 8450
8450 RETURN
8455 H9=H1
8460 GO TO 8495
8465 H9=H2
8470 GO TO 8495
8475 H9=H3
8480 GO TO 8495
8485 H9=H4
8490 GO TO 8495
8495 IF H9<=100 THEN 8515
8500 PRINT 'APP HUM CHANGED FROM ';H9;' TO 100; TIME-TAG=';INT(P(3,N))
8505 H9=100
8510 REM:THIS PROG MODIFIED, DEBUGGED & WORKING AT SBRT LEVEL. MCW770809
8515 RETURN
9000 REM:LAG-COMP HUM. INPUTS- HUM C7, TEMP C6, HUM RATE C5; OUTPUT G6
9001 REM:J1=HUM LAG-COMP SETTING (0-1: NONE-FULL)
9005 IF C5<0 THEN 9020
9010 G6=0.17*(273.16/(C6+273.16))+0.36*(273.16/(C6+273.16))17
9015 GO TO 9025
9020 G6=0.2*(273.16/(C6+273.16))+0.75*(273.16/(C6+273.16))19.3
9025 G6=C7+G6*C5*J1
9030 REM:END OF HYGRISTOR LAG-COMPENSATION PROG
9035 RETURN
9100 STOP
9110 PRINT 'SAFE PROG CASS IN CONSOL . WEN RDY FOR FILE 4, ENTR R - ';
9120 INPUT S$
9130 IF S$='R' THEN 9150
9140 GO TO 9110
9150 FIND 4
9160 DELETE 4750,6960
9170 DELETE 8000,9140
9180 APPEND 9200
9200 REM:FILE 4 GETS APPENDED HERE

```

Figure D-3. Listing for Third File of Baroswitch  
Dropsonde Program (Page 8 of 8)



```

9200 REM:FILE4. TO BE APPENDED TO FILE 3 AT LINE 9200
9210 DELETE 9150,9180
9230 REM:EXTRAPOLATE PRES TO SURFACE. U9=SURF TAG, U8=LAST BK TAG
9240 REM:U7=2ND LAST BK TAG, U6=LAST BK PRES, U5=2ND LAST BK PRES
9250 U9=(INT(P(1,P(1,400))) MAX INT(P(3,P(3,400))))+4
9260 F(100)=F(100)+1
9270 U8=INT(F(F(100)-1))
9280 U7=INT(F(F(100)-2))
9290 U6=F(F(100)-1)-U8
9300 U5=F(F(100)-2)-U7
9320 S9=U9+U5+(U9-U7)/(U8-U7)*(U6-U5)
9325 PRINT 'OPR-ENTERED SURFACE PRES ESTIMATE = ';P2;' MB.'
9330 PRINT 'TAGGED-PRES EXTRAPOLATION TO SURF= ';S9
9340 PRINT ' ','WANT TO CHANGE XTRAPLTD PRES? ENTR 1(+) OR 2(-) - ';
9350 INPUT Z9
9360 GO TO Z9 OF 9380,9400
9370 GO TO 9340
9380 PRINT 'ENTR DESIRED MB PRES FOR SURFACE (PPPP.P) -- ';
9382 INPUT S9
9384 REM:EXTRAPOLATE & BUILD TAG.P FOR SURFACE
9386 Z9=F(F(100)-1)-INT(F(F(100)-1))
9387 Z8=F(F(100)-2)-INT(F(F(100)-2))
9388 Z9=(S9/10000-Z8)/(Z9-Z8)
9390 Z9=INT(F(F(100)-2))+Z9*(INT(F(F(100)-1))-INT(F(F(100)-2)))
9392 S9=INT(Z9+0.5)+S9/10000
9400 PRINT 'F(100)=';F(100)
9402 PRINT 'WILL STORE ENTRY AS FOLLOWS: F(';F(100);')=';S9
9404 PRINT 'WANT TO REENTER BEFORE STORAGE? ENTR 1(+) OR 2(-)';
9410 INPUT Z9
9420 GO TO Z9 OF 9440,9450
9430 GO TO 9400
9440 GO TO 9380
9450 F(F(100))=S9
9455 REM:ASSIGN TEMP & HUM AT SURF
9460 PRINT 'LAST TAG.TEMP & TAG.HUM= ';P(1,P(1,400));' & ';P(3,P(3,400))
9470 PRINT ' OK TO EXTEND THESE VALUES TO SURF? 1 (YES) 2 (NO) -- ';
9480 INPUT Z9
9490 GO TO Z9 OF 9540,9510
9500 GO TO 9460
9510 PRINT 'ENTR SURF TAG.T & TAG.H (TTTT.TTT,TTTT.HHHH)- ';
9520 INPUT P(1,P(1,400)+1),P(3,P(3,400)+1)
9525 P(1,400)=P(1,400)+1
9530 P(3,400)=P(3,400)+1
9535 GO TO 9590
9540 REM:EXTEND LAST T & H TO SURF (IF OPR-SELECTED)
9541 FOR N=1 TO 3 STEP 2
9545 IF INT(P(N,P(N,400)))=INT(F(F(100))) THEN 9570
9550 P(N,P(N,400)+1)=INT(F(F(100)))+P(N,P(N,400))-INT(P(N,P(N,400)))
9560 P(N,400)=P(N,400)+1
9570 NEXT N
9590 REM:CALC ALTITUDE.REFRACTIVITY PROFILE F(2,N)

```

Figure D-4. Listing for Four File of Baroswitch  
Dropsonde Program (Page 1 of 10)



```

9600 REM:SET SURF ALT=0
9610 P(2,400)=P(3,400)
9620 FOR N=1 TO 399
9630 P(2,N)=0
9640 NEXT N
9650 REM:FETCH SURFACE PRES
9660 V9=10000*(F(F(100))-INT(F(F(100))))
9670 REM:CALC LAYER THICKNESSES, INT(P(2,N)) CENTIFEET, V9=BOTTOM PRES,
9680 REM:V8=TOP PR, V7=AVG RH, V6=AVG TEMP, V5=SAT VAP PR, V4=THKNS (M)
9690 FOR N=P(3,400)-1 TO 1 STEP -1
9700 REM:FETCH TOP PRES
9710 V8=F(100)
9720 V8=V8-1
9730 IF INT(F(V8))<=INT(P(3,N)) AND V8>1 THEN 9770
9740 IF V8>1 THEN 9720
9742 IF V8<=1 THEN 9750
9744 PRINT 'REACHED END OF PRES FILE WITH ';N;' LAYER(S) NOT CALCULATED'
9746 GO TO 9940
9750 LIST 9740
9760 STOP
9770 Z9=(INT(P(3,N))-INT(F(V8+1)))/(INT(F(V8))-INT(F(V8+1)))
9780 Z9=Z9*(F(V8)-INT(F(V8))-(F(V8+1)-INT(F(V8+1))))
9790 V8=10000*(F(V8+1)-INT(F(V8+1))+Z9)
9792 IF V8<V9 THEN 9800
9794 LIST 9792
9796 PRINT 'TOP PR=';V8,'BOTTOM PR=';V9
9798 STOP
9800 REM:CALC AVG RH
9810 V7=500*(P(3,N)-INT(P(3,N))+P(3,N+1)-INT(P(3,N+1)))
9820 REM:FETCH AVG TEMP V6
9830 D9=(INT(P(3,N))+INT(P(3,N+1)))/2
9840 GOSUB 7000
9850 V6=D9
9860 REM:CALC SAT VAP PRES V5 USING V6
9870 GOSUB 15000
9880 REM:CALC THICKNESS V4 & INCREMENT ALTITUDE INT(P(2,N))
9890 V4=28.8*(V6+273.16)*(V9*V8)^0.5
9900 V4=V4/(0.18*V7*V5+28.8*((V9*V8)^0.5-0.01*V7*V5))
9910 V4=-29.263242*V4*(LOG(V8/1000)-LOG(V9/1000))
9912 IF V4>0 THEN 9920
9914 LIST 9912
9916 PRINT 'THKNS=';V4,'N=';N
9918 STOP
9920 P(2,N)=P(2,N+1)+INT(100*V4/0.3048+0.5)
9925 V9=V8
9930 NEXT N
9940 PRINT 'WANT CENTIFT ALTS CORRESPND'G TO HUM VALUES? 1(+), 2(-) - ';
9950 INPUT Z9
9960 GO TO Z9 OF 9980,10000
9970 GO TO 9940
9980 PRINT @41:'FOLLOWING ARE LISTS OF TAG.TEMP, ALT.0, TAG.HUM:'

```

Figure D-4. Listing for Fourth File of Baroswitch  
Dropsonde Program (Page 2 of 10)



```

9990 PRINT @41:F
10000 REM:CALC REFRACTIVITIES & ADD TO ALTS
10010 FOR N=1 TO F(3,400)
10020 REM:GET TIME-TAG D9 FOR SAMPLE F(3,N)
10030 D9=INT(F(3,N))
10040 REM:FETCH TEMP D8 AT TAG D9
10050 GOSUB 7000
10060 V6=D8
10070 REM:CALC SAT VAP PRES V5 FOR TEMP V6
10080 GOSUB 15000
10090 REM:FETCH PRES V8 MB FOR TAG D9
10100 V8=D9
10105 IF F(2,N)=0 AND N<>P(2,400) THEN 10160
10110 GOSUB 20000
10115 IF V8=9999 THEN 10160
10120 REM:CALC REFR'Y N-UNITS, V4
10125 Z9=1000*(F(3,N)-INT(F(3,N)))
10130 V4=(77.6*V8-0.056*Z9*V5)/(D8+273.16)
10140 V4=V4+3750*Z9*V5/(D8+273.16)^2
10150 F(2,N)=F(2,N)+V4/1000
10160 NEXT N
10170 PRINT "WANT P(2,N) LIST OF ALT.N ? 1(+) OR 2(-) -- ";
10180 INPUT Z9
10190 GO TO Z9 OF 10220,10230
10200 GO TO 10170
10210 PRINT @41:"FOLLOWING ARE LISTS OF TAG.T, ALT.N, TAG.H:"
10220 PRINT @41:F
10230 GO TO 21000
15000 REM:CALC SAT VAP FR V5 MB FOR TEMP V6 DEG C; Z9=(1-t)/t
15010 Z9=(1-(V6+273.16)/373.16)/((V6+273.16)/373.16)
15020 V5=1013.246*10^(0.0081238*(10^(-3.49149*Z9)-1))
15030 Z8=(V6+273.16)/373.16
15040 V5=V5/(Z8^5.02808*10^(7.90298*Z9))
15050 V5=V5/10^(1.3816E-7*(10^(11.344*(1-Z8))-1))
15060 RETURN
20000 REM:FETCH PRES V8 MB FOR TAG D9
20010 IF D9=>INT(F(1)) AND D9<=INT(F(F(100))) THEN 20060
20020 LIST 20010
20030 PRINT "TAG=";D9;" & IS OUTSIDE TAG RANGE FOR PRES FILE"
20035 PRINT "NON-VALID CODE **9999** APPLIED TO PRES V8 (AT N=";N;")"
20040 V8=9999
20045 GO TO 20170
20060 Z9=1
20070 Z9=Z9+1
20080 IF INT(F(Z9))=>D9 THEN 20140
20090 GO TO 20070
20140 V8=(D9-INT(F(Z9-1)))/(INT(F(Z9))-INT(F(Z9-1)))
20150 V8=V8*(F(Z9)-INT(F(Z9))-(F(Z9-1)-INT(F(Z9-1))))
20160 V8=10000*(F(Z9-1)-INT(F(Z9-1))+V8)
20170 RETURN
21000 REM:LIST FT,M,MB,DEG-C,%RH,N,M-UNITS,G/M3,D-PT-DEP,N/H,N/H-CLASS
21002 PRINT @41:

```

Figure D-4. Listing for Fourth File of Baroswitch  
Dropsonde Program (Page 3 of 10)



```

21004 PRINT @41:
21006 PRINT @41: " ", "DETAILED LIST OF ATMOSPHERIC PARAMETERS"
21008 PRINT @41:
21010 PRINT @41: "ALT(FT)  ALT(M)  PR(MB)  T(DEG-C)  RH(%)  N-UNITS ";
21020 PRINT @41: " M-UNITS  G/M3  D-PT-DEF  N/M  N/M-CLASS"
21030 Z$=" -----"
21040 PRINT @41: Z$; Z$; " -----"
21050 REM: W9=NTH VALUE OF ALT(FT), W8=NTH VALUE OF REFR'Y
21060 FOR N=1 TO P(2,400)
21070 W9=0.01*INT(P(2,N))
21072 IF W9=0 AND N<P(2,400) THEN 21400
21080 W8=1000*(P(2,N)-INT(P(2,N)))
21110 REM: FETCH PR V8 MB FOR TAG D9
21120 D9=INT(P(3,N))
21130 GOSUB 20000
21132 IF V8=9999 THEN 21400
21140 REM: FETCH TEMP D8 DEG C FOR TAG D9
21150 GOSUB 7000
21170 W1=1000*(P(3,N)-INT(P(3,N)))
21180 GOSUB 21420
21190 IMAGE6D.X,6D.X,5D.DX,4D.2DX,5D.DX,5D.DX,6D.X,4D.2DX,5D.DX
21200 PRINT @41: USING 21190: W9; 0.3048*W9; V8; D8; W1; W8; W8+0.048*W9; W2; W3
21210 IF N=P(2,400) THEN 21400
21220 W7=0.01*INT(P(2,N+1))
21230 W6=1000*(P(2,N+1)-INT(P(2,N+1)))
21240 REM: CALC N/M GRAD W5
21250 W5=(W8-W6)/(W9-W7)/0.3048
21280 IF W5<-0.07874 THEN 21340
21290 IF W5<0 THEN 21320
21300 W$=" SUBFR+ "
21310 GO TO 21390
21320 W$=" NORML- "
21330 GO TO 21390
21340 IF W5<-0.1575 THEN 21380
21360 W$=" SPRF-- "
21370 GO TO 21390
21380 W$=" TRF--- "
21390 PRINT @41: USING "74D.4DX,8A": W5; W$
21400 NEXT N
21410 GO TO 21580
21420 REM: CALC ABS HUM W2 GRAMS/CUBIC-M AND DEW POINT DEF W3 DEG C
21425 REM: FIRST CALC W2
21430 V6=D8
21440 GOSUB 15000
21450 W2=596*10*(P(3,N)-INT(P(3,N)))*V5/1013.25*373.16/(D8+273.16)
21455 REM: ENTR SBRT HERE IF W2 IS KNOWN & ONLY W3 IS WANTED
21460 REM: NOW CALC DEW-POINT DEF W3
21470 V6=D8
21480 GOSUB 15000
21490 W4=0.01*(1000*(P(3,N)-INT(P(3,N))))*V5
21500 V4=V5
21510 V6=D8-1

```

Figure D-4. Listing for Fourth File of Baroswitch  
Dropsonde Program (Page 4 of 10)



```

21520 GOSUB 15000
21530 IF ABS(V5-W4)<1.0E-3*W4 THEN 21560
21540 V6=D8-(D8-V6)*(V4-W4)/(V4-V5)
21550 GO TO 21520
21560 W3=D8-V6
21570 RETURN
21580 LIST 21600
21585 PRINT 'IF WANT COPY DISPLAY, DO SO BEFOR CONTINUING RUN'
21590 STOP
21600 REM:END OF PRINTOUT; WILL GO TO PLOT.
30000 REM:PLOT ALTITUDE PROFILES OF TEMP & HUM
30005 PAGE
30010 REM:SELECT ALT SCALE
30011 N=1
30012 U0=0
30014 U0=U0 MAX INT(P(2,N))
30015 IF U0>INT(P(2,N)) THEN 30020
30017 N=N+1
30018 GO TO 30014
30020 IF 0.01*U0>15000 THEN 30050
30030 U0=15000
30040 GO TO 30095
30050 U0=30000
30095 REM:PLOT TEMP AXES
30100 VIEWPORT 5,75,5,95
30110 WINDOW -40,30,-500,U0
30120 AXIS 5,U0/15,-40,0
30130 MOVE -40,U0
30140 PRINT 'KHHKFT', 'TEMP(DEG C)', ' ', 'RH(%)'
30150 PRINT U0/1000, ' ', 'HHDROP #';N$;'JHHHHHHH';D
30160 MOVE -40,2*U0/3
30170 PRINT 'HH';2*U0/3000
30180 MOVE -40,U0/3
30190 PRINT 'HH';U0/3000
30200 MOVE -40,0
30210 PRINT 'H0'
30220 MOVE 0,-500
30230 PRINT 'JOK'
30240 MOVE -20,-500
30250 PRINT 'JHH-20K'
30260 MOVE 20,-500
30270 PRINT 'JH20K'
30280 REM:PLOT TEMPS
30290 D7=1
30300 FOR N=2 TO P(3,400)
30310 D9=INT(P(3,N-1))
30320 GOSUB 7000
30325 D0=0.01*INT(P(2,N-1))
30330 IF ABS(D8)>60 OR D0=0 THEN 30390
30340 MOVE D8,D0
30350 D9=INT(P(3,N))
30360 GOSUB 7000
30365 D0=0.01*INT(P(2,N))

```

Figure D-4. Listing for Fourth File of Baroswitch  
Dropsonde Program (Page 5 of 10)



```

30370 IF ABS(D9)>60 OR D0=0 THEN 30390
30380 DRAW D8,D0
30390 NEXT N
30395 REM:PLOT HUM AXES
30400 VIEWPORT 77,127,5,95
30410 WINDOW 0,100,-500,U0
30420 AXIS 10,U0/15
30430 MOVE 0,-500
30440 PRINT 'JOK'
30450 MOVE 50,-500
30460 PRINT 'JH50K'
30470 MOVE 100,-500
30480 PRINT 'JHH100K'
30490 REM:PLOT HUMS
30500 FOR N=2 TO P(3,400)
30510 D9=1000*(P(3,N-1)-INT(P(3,N-1)))
30515 D0=0.01*INT(P(2,N-1))
30520 IF D9>100 OR D0=0 THEN 30570
30530 MOVE D9,D0
30540 D9=1000*(P(3,N)-INT(P(3,N)))
30545 D0=0.01*INT(P(2,N))
30550 IF D9>100 OR D0=0 THEN 30570
30560 DRAW D9,D0
30570 NEXT N
30580 COPY
30582 COPY
30584 COPY
40000 REM:PLOT ALTITUDE PROFILES OF N- & M-UNITS
40050 VIEWPORT 5,75,5,95
40060 WINDOW 200,400,-500,U0
40070 AXIS 20,U0/15,200,0
40080 MOVE 200,U0
40090 PRINT 'KBHKT','REFRY(N-UNITS)', ' ','M-UNITS'
40100 PRINT U0/1000,' ','BHROP #';N$;'JHHHHHHH';D
40110 MOVE 200,2*U0/3
40120 PRINT 'HH';2*U0/3000
40130 MOVE 200,U0/3
40140 PRINT 'HH';U0/3000
40150 MOVE 200,0
40160 PRINT 'H0'
40170 MOVE 300,-500
40180 PRINT 'JH300K'
40190 MOVE 240,-500
40200 PRINT 'JH240K'
40210 MOVE 360,-500
40220 PRINT 'JH360K'
40230 REM:PLOT N-UNITS
40240 D7=1
40250 FOR N=2 TO P(2,400)
40260 D8=1000*(P(2,N-1)-INT(P(2,N-1)))
40270 D0=0.01*INT(P(2,N-1))
40280 IF ABS(D8-600)>400 OR D0=0 THEN 40340

```

Figure D-4. Listing for Fourth File of Baroswitch Dropsonde Program (Page 6 of 10)



```

40290 MOVE D8,D0
40300 D8=1000*(F(2,N)-INT(F(2,N)))
40310 D0=0.01*INT(F(2,N))
40320 IF ABS(D8-600)>400 OR D0=0 THEN 40340
40330 DRAW D8,D0
40340 NEXT N
40350 VIEWPORT 77,127,5,95
40360 WINDOW 300,900,-500,U0
40370 AXIS 100,U0/15,300,0
40380 MOVE 300,-500
40390 PRINT 'JH300K'
40400 MOVE 600,-500
40410 PRINT 'JH600K'
40420 MOVE 900,-500
40430 PRINT 'JH900K'
40440 REM:PLOT M-UNITS
40450 FOR N=2 TO F(2,400)
40460 D9=1000*(F(2,N-1)-INT(F(2,N-1)))
40465 D9=D9+0.048*0.01*INT(F(2,N-1))
40467 D0=0.01*INT(F(2,N-1))
40470 IF ABS(D9-600)>390 OR D0=0 THEN 40520
40480 MOVE D9,D0
40490 D9=1000*(F(2,N)-INT(F(2,N)))
40495 D9=D9+0.048*0.01*INT(F(2,N))
40497 D0=0.01*INT(F(2,N))
40500 IF ABS(D9-600)>390 OR D0=0 THEN 40520
40510 DRAW D9,D0
40520 NEXT N
40522 COPY
40524 COPY
40526 COPY
40528 PAGE
45000 REM:LIST SIGNIF LEVELS (BASED ON LINEAR FIT OF T&H TO ALT)
45002 PRINT @41:
45003 PRINT @41:
45005 PRI @41:' ', 'SIGNIF LEVS (T1,H10) LIST OF ATMOSPHERIC PARAMETERS'
45007 PRINT @41:
45010 DELETE S
45020 DIM S(2,9),D(9)
45030 RESTORE 45050
45040 READ @34:S9,S8,S,0,M
45050 DATA 2,0,1.0E-3,0,-9.0E+99,9.0E+99,0,0,0,0,0.01,0,-9.0E+99
45055 DATA 9.0E+99,0,0,0,0,0,9.0E+99,0,0,0,0,0,0,1
45060 REM:LIST FT,M,MB,DEG-C,%RH,N,M-UNITS,G/M3,D-PT-DEF
45070 PRINT @41:'ALT(FT) ALT(M) PR(MB) T(DEG-C) RH(%) N-UNITS ':
45080 PRINT @41:' M-UNITS G/M3 D-PT-DEF'
45090 Z$=' -----'
45100 PRINT @41:Z$;Z$;' -----'
45110 REM:W9=NTH VALUE OF ALT(FT), W8=NTH VALUE OF REFR'Y
45120 FOR N=F(2,400) TO 1 STEP -1
45130 W9=0.01*INT(F(2,N))
45150 W8=1000*(F(2,N)-INT(F(2,N)))

```

Figure D-4. Listing for Fourth File of Baroswitch  
Dropsonde Program (Page 7 of 10)



```

45160 REM:FETCH PR V8 MB FOR TAG D9
45170 D9=INT(F(3,N))
45180 GOSUB 20000
45190 IF V8=9999 THEN 45500
45200 REM:FETCH TEMP D8 DEG C FOR TAG D9
45210 GOSUB 7000
45220 W1=1000*(F(3,N)-INT(F(3,N)))
45222 REM:CALC ABS HUM W2 & DEW-PT-DEF W3
45224 GOSUB 21420
45230 F9=1.1+D8/1000
45240 N9=100*W9+1.0E-3
45250 IF N9=1.0E-3 AND INT(S(M,9))=0 AND INT(S(M,2))>0 THEN 45500
45260 GOSUB 45520
45270 F9=2+W1/1000
45280 GOSUB 45520
45285 IF N=1 THEN 45300
45290 IF S8<>1 THEN 45340
45300 S8=0
45320 IMAGE6D.X,6D.X,5D.DX,4D.2DX,5D.DX,5D.DX,6D.X,4D.2DX,5D.DX
45330 PRINT @41: USING 45320:D
45340 D(1)=W9
45350 D(2)=0.3048*W9
45360 D(3)=V8
45370 D(4)=D8
45380 D(5)=W1
45390 D(6)=W8
45400 D(7)=W8+0.048*W9
45410 D(8)=W2
45420 D(9)=W3
45500 NEXT N
45510 GO TO 49000
45520 REM:FIND SIGNIFICANT VALUES
45530 REM:INPUT IS ID-TAGGED VALUE P9 & LINEARITY BASE N9
45540 REM:INPUT TOLERANCES ARE S(M,1)
45550 REM:OUTPUTS:BASE-TAGGED VALUES S(M,2) WITH FLAG S8=1 WEN SIGNIF
45560 M=INT(P9)
45570 REM:CALCULATE NEW SLOPE S(M,5)
45580 S(M,5)=(P9-INT(P9)-(S(M,2)-INT(S(M,2))))/(N9-INT(S(M,2)))
45660 REM:TEST NEW SLOPE
45670 IF S(M,5)>S(M,3) AND S(M,5)<=S(M,4) THEN 45692
45680 REM:NEW SLOPE NOT OK; SET FLAG
45690 S8=1
45692 REM:UPDATE LAST LEVEL
45694 S(M,8)=S(M,9)
45696 S(M,9)=INT(N9)+(P9-INT(P9))
45700 IF M<S9 THEN 45930
45720 REM:FOR ALL M, DECLARE LAST VALUE IF SIGNIF, SET NEW LIMITS
45730 FOR M=1 TO S9
45735 IF S8<>1 THEN 45762
45740 S(M,2)=S(M,8)
45750 S(M,3)=-9.0E+99
45760 S(M,4)=9.0E+99
45762 REM:CALCULATE NEW ACCEPTANCE SLOPE LIMITS

```

Figure D-4. Listing for Fourth File of Baroswitch  
Dropsonde Program (Page 8 of 10)



```

45764 IF N9>INT(S(M,2)) THEN 45772
45766 S(M,6)=S(M,9)-INT(S(M,9))+S(M,1)-(S(M,2)-INT(S(M,2)))
45767 S(M,6)=S(M,6)/(N9-INT(S(M,2)))
45768 S(M,7)=S(M,9)-INT(S(M,9))-S(M,1)-(S(M,2)-INT(S(M,2)))
45769 S(M,7)=S(M,7)/(N9-INT(S(M,2)))
45770 GO TO 45780
45772 S(M,6)=S(M,9)-INT(S(M,9))-S(M,1)-(S(M,2)-INT(S(M,2)))
45773 S(M,6)=S(M,6)/(N9-INT(S(M,2)))
45774 S(M,7)=S(M,9)-INT(S(M,9))+S(M,1)-(S(M,2)-INT(S(M,2)))
45775 S(M,7)=S(M,7)/(N9-INT(S(M,2)))
45780 REM:UPDATE SLOPE ACCEPTANCE LIMITS. START WITH TEST OF MIN SLOPE
45790 IF S(M,6)>S(M,3) THEN 45820
45800 REM:MIN ACCEPTABLE SLOPE OK AS IS
45810 GO TO 45840
45820 REM:UPDATE MIN ACCEPTABLE SLOPE
45830 S(M,3)=S(M,6)
45840 REM:NOW TEST MAX SLOPE
45850 IF S(M,7)<S(M,4) THEN 45880
45860 REM:MAX ACCEPTABLE SLOPE O.K. AS IS
45870 GO TO 45900
45880 REM:UPDATE MAX ACCEPTABLE SLOPE
45890 S(M,4)=S(M,7)
45900 NEXT M
45901 M=M-1
45930 RETURN
49000 REM:LIST ATMOSPHERIC PARAMETERS AT MANDATORY PRES LEVELS Y(M)
49001 PRINT @41:
49002 PRINT @41:
49003 PRINT @41: " ", "MANDATORY LEVELS"
49004 PRINT @41:
49005 PRINT @41: "ALT(FT) ALT(M) PR(MB) T(DEG-C) RH(%) N-UNITS ";
49006 PRINT @41: " M-UNITS G/M3 D-FT-DEF"
49007 Z$= " ----- "
49008 PRINT @41: Z$; Z$; " ----- "
49010 DIM Y(7)
49020 RESTORE 49040
49030 READ @34: Y, M
49040 DATA 1000, 850, 700, 500, 400, 300, 250, 0
49050 REM:FETCH SURF PRES FROM F ARRAY
49060 V8=10000*(F(F(100))-INT(F(F(100))))
49070 REM:FETCH TIME-TAG D9 FROM F ARRAY USING PR V8
49080 GOSUB 49370
49090 REM:USE TAG D9 IN P(3,N) TO FIND N & INTERP FRACTION NO
49095 IF D9=1 THEN 49360
49100 GOSUB 49510
49110 REM:USE N & NO TO GET ALT W9 FROM I(2,N)
49120 W9=INT(P(2,N))
49130 Z9=INT(P(2,N-1))
49140 W9=0.01*(W9+NO*(Z9-W9))
49150 REM:USE N & NO TO GET N-UNITS W8 FROM P(2,N)
49160 W8=P(2,N)-INT(P(2,N))
49170 Z9=P(2,N-1)-INT(P(2,N-1))

```

Figure D-4. Listing for Fourth File of Baroswitch  
Dropsonde Program (Page 9 of 10)



```

49180 W8=1000*(W8+N0*(Z9-W8))
49190 REM:FETCH TEMP D8 FOR TAG D9
49200 GOSUB 7000
49210 REM:USE N & N0 TO GET ZRH, W1
49220 W1=P(3,N)-INT(P(3,N))
49230 Z9=P(3,N-1)-INT(P(3,N-1))
49240 W1=1000*(W1+N0*(Z9-W1))
49250 REM:CALC ABS HUM W2
49252 V6=D8
49254 GOSUB 15000
49256 W2=596*0.01*W1*V5/1013.25*373.16/(D8+273.16)
49258 REM:CALC DEW-PT-DEF W3
49260 GOSUB 21455
49270 PRINT @41: USING 45320:W9,0.3048*W9,V8,D8,W1,W8,W8+0.048*W9,W2,W3
49280 IF M>0 THEN 49320
49290 REM:SURF PR DONE. OMIT 1000 MB IF SURF PR <=1000
49300 IF V8>1000 THEN 49320
49310 M=M+1
49320 M=M+1
49330 IF M=8 THEN 49360
49340 V8=Y(M)
49350 GO TO 49070
49355 PRINT 'END OF PROCESSING'
49360 END
49370 REM:FETCH TAG D9 FOR PR V8
49380 D9=F(100)
49390 Z8=10000*(F(D9)-INT(F(D9)))
49400 Z9=10000*(F(D9-1)-INT(F(D9-1)))
49410 IF V8<Z9 THEN 49480
49420 IF V8<=Z8 THEN 49460
49430 LIST 49420
49440 PRINT 'PR V8 TOO GREAT FOR TABLE F( )'
49450 STOP
49460 D9=INT(F(D9))+INT((V8-Z8)/(Z9-Z8)*(INT(F(D9-1))-INT(F(D9)))+0.5)
49470 GO TO 49500
49480 D9=D9-1
49485 IF D9=1 THEN 49500
49490 GO TO 49390
49500 RETURN
49510 REM:USE TAG D9 TO FIND INTERP BASE N & FRACTION N0 FROM P(3, )
49520 N=P(3,400)
49530 Z8=INT(P(3,N))
49540 Z9=INT(P(3,N-1))
49550 IF D9<Z9 THEN 49620
49560 IF D9<=Z8 THEN 49600
49570 LIST 49560
49580 PRINT 'TAG D9 > TABLE TAGS'
49590 STOP
49600 N0=(D9-Z8)/(Z9-Z8)
49610 GO TO 49640
49620 N=N-1
49630 GO TO 49530
49640 RETURN

```

Figure D-4. Listing for Fourth File of Baroswitch  
Dropsonde Program (Page 10 of 10)



APPENDIX E  
PROGRAM LISTING FOR CAPS DROPSONDE ANALYSIS



APPENDIX E. PROGRAM LISTING FOR CAPS DROPSONDE ANALYSIS

The four program files of cassette IX, CAPS Dropsonde Analysis, are listed in the four figures of this appendix as tabulated below.

<u>Cassette Number</u>	<u>File on Cassette</u>	<u>Program Name</u>	<u>Figure Number</u>
IX	1	CALIBRATION AND ACQUISITION	E-1
IX	2	REDUCED FILE BUILDER	E-2
IX	3	TEMP, PRES, HUM TABLE BUILDER	E-3
IX	4	OUTPUT REPORT GENERATOR	E-4



```

100 GO TO 1000
110 DELETE 1000,3110
120 PRINT 'SET HP AS ADDR 3 FOR INPUT. ENTER MINUTES OF DATA ( <11.0 )'
130 INIT
140 Y=0
160 INPUT M
170 M=320*M+160
180 DIM Z$(2),T(M),U$(17),T$(14)
185 T=0
190 PRINT @3,32:'PF7G1S17;R'
200 ON SRQ THEN 220
210 WAIT
220 FOR N=1 TO M
230 INPUT @3:U$
240 T$=SEG(U$,7,6)
250 INPUT @3:U$
260 U$=SEG(U$,6,7)
270 T$=T$&U$
280 T(N)=VAL(T$)
290 NEXT N
300 OFF SRQ
310 PRINT 'PRS CR WEN RDY TO CK INPUT'
320 INPUT Z$
330 PRINT T
360 PRINT 'ENTER 1(REDISPLAY) OR 2(CONTINUE) OR 3(ABORT)'
370 INPUT Z$
380 GO TO VAL(Z$) OF 310,410,390
390 PRINT 'RUN ABORTED'
400 END
410 PRINT 'PREPARE TO STORE DATA ON INTERNAL TAPE. ENTER FILE NO.'
420 INPUT Y
430 PRINT 'WILL STORE IN FILE ';Y;'. ENTER + WEN RDY'
440 INPUT Z$
450 IF Z$='+' THEN 490
460 LIST 410
470 PRINT 'RUN ABORTED'
480 STOP
490 FIND Y
500 MARK 1,10*(M+1)
510 FIND Y
515 WRITE M
520 WRITE T
550 PRINT 'FILE WRITTEN'
560 END
1000 PAGE
1005 PRINT '          REFRACTION DROPSONDE DATA ANALYZER -- NADC AVTD'
1010 PRINT
1020 PRINT 'ENTER PROG SELECTION 1 OR 2: 1-CAL&ACQ 2-ANALYSIS -- ';
1030 INPUT Z
1040 GO TO Z OF 2000,3000
2000 INIT

```

Figure E-1. Listing for First File of CAPS Dropsonde Program, 8 June 1978 (Page 1 of 3)



```

2010 PRINT ' ', 'CALIBRATION AND DATA ACQUISITION'
2020 PRINT
2030 PRINT
2050 PRINT 'ENTER DROP DATE AND NUMBER (YYMMDD NN) -- ';
2060 INPUT D,N$
2070 PRINT 'ENTER ZULU LAUNCH TIME (HHMMSS) -- ';
2080 INPUT T$
2090 PRINT 'ENTER ZULU SPLASH TIME (HHMMSS) -- ';
2100 INPUT U$
2110 PRI 'ENTER PRESSURE ALT AT LAUNCH & PRES AT SURFACE (KFT,MB) -- ';
2120 INPUT P1,P2
2130 PRINT 'ENTER SONDE SERIAL NO. (NNNNNN) -- ';
2140 INPUT S$
2144 PRINT 'ENTER REFERENCE VOLTAGE RATIO -- ';
2146 INPUT K0
2150 PRINT 'THERM LOCKIN: ENTER KOHMS AND DEG C (RR.RRR ,TT.T) -- ';
2160 INPUT R3,T3
2170 PRINT 'ENTER HUML LOCKIN RES IN KOHMS (RR.RRR) -- ';
2180 INPUT R4
2181 DIM L(3,6)
2182 PRINT 'ENT PRES COEF L(1,1-6) ';
2183 INPUT L(1,1),L(1,2),L(1,3),L(1,4),L(1,5),L(1,6)
2185 PRINT 'ENT PRES COEF L(2,1-6) ';
2186 INPUT L(2,1),L(2,2),L(2,3),L(2,4),L(2,5),L(2,6)
2188 PRINT 'ENT PRES COEF L(3,1-6) ';
2189 INPUT L(3,1),L(3,2),L(3,3),L(3,4),L(3,5),L(3,6)
2210 PRINT 'ENTER OPERATOR-DATE CODE (ABCYYMMDD) -- ';
2220 INPUT O$
2432 PRINT 'IF WANT COPY OF THIS PAGE, ENTER + (IF NOT, ENTER -) -- ';
2434 INPUT Z$
2436 IF Z$<>'+' THEN 2440
2438 COPY
2440 PAGE
2450 PRI 'DATE(YYMMDD): ';D;' DROP NO. ';N$;' SONDE SER. NO. ';S$
2470 PRINT
2480 PRI 'THERM LOCK-IN: ';R3;' KOHMS AT ';T3;' DEG C', ' HUML: ';R4;'K'
2490 PRINT
2500 PRINT ' ', 'LAUNCH', 'SPLASH'
2510 PRINT 'TIME (HHMMSS)', T$, U$
2515 PRINT
2520 PRINT 'PRES. (KFT,MB)', P1, P2
2530 PRINT
2534 PRINT 'PRESSURE COEFF OF ARRAY L(3,6) ARE AS FOLLOWS:'
2536 PRINT L
2538 PRINT
2560 PRINT ' ', O$
2570 PRINT 'WANT CHANGE CAL DATA? (ENTR+ IF YES, - IF NO):'
2575 INPUT Z$
2580 IF Z$<>'-' THEN 2584
2582 GO TO 2630
2584 PRINT 'ENTR CHANGE (EG:P1=NN.N) THEN RUN AFTER STOP'
2586 STOP

```

Figure E-1. Listing for First File of CAPS Dropsonde Program, 8 June 1978 (Page 2 of 3)



```

2588 GO TO 2440
2630 COPY
2632 PRINT @41:
2634 PRINT @41:
2636 PRI @41:"DATE(YMMDD): ";D;" DROP NO.;"N$;" SONDE SER. NO. ";S$
2637 PRI @41:"THER LOC-IN: ";R3;" KOHMS @ ";T3;" DEG C"," HUML: ";R4;"K"
2638 PRINT @41:"LAUNCH ALT ";P1;"KFT","LAUNCH PRES ";P2;"MB"
2639 PRINT @41:"PRESSURE COEFF OF ARRAY L(3,6) ARE AS FOLLOWS:"
2640 PRINT @41:L
2645 PAGE
2660 PRI "PREPARE TO STORE CAL DATA: NOTE CASS NO. & LOAD CASS IN 4051"
2665 PRINT "ASCERTAIN FILE 1 ON CASS HAS BEEN MARKED BEFORE CONTINUING"
2670 PRINT "ENTER CASSETTE NO. AND ADDRESS OF CASSETTE UNIT (NN) -- ";
2680 INPUT X
2690 TLIST
2695 PRINT "ANY FILE # >= SPECIFIED # WILL BE DESTROYED"
2700 PRINT "ENTER FILE NO. FOR STORING CAL DATA (FF) -- ";
2710 INPUT Z1
2720 FIND Z1
2730 MARK 1,3000
2740 FIND Z1
2750 PRINT @33:D,N$,T$,U$,P1,P2,S$,T3,R3,R4,L,K0,0$
2755 CLOSE
2760 PRINT "CAL DATA STORED IN FILE ";Z1;" ON CASSETTE ";X;" ";0$
2761 PRINT "IF WANT TO WRITE ANOTHER CAL DATA FILE, ENTER + (- IF NOT)"
2762 INPUT Z$
2763 IF Z$="+" THEN 2660
2765 GO TO 110
2990 STOP
3000 REM:DATA ANALYSIS STARTS HERE
3010 DELETE 100,2990
3020 PRINT "WILL READ DATA ANALYSIS PROG FROM INTERNAL CASSETTE FILE 2"
3030 PRINT " ENTER R WEN RDY -- ";
3040 INPUT S$
3050 IF S$="R" THEN 3090
3060 LIST 3020
3070 PRINT "RUN ABORTED"
3080 STOP
3090 FIND 2
3100 APPEND 3110
3105 REM:FILED IN CASS 8, FILE 1. PK-MCW-780216
3107 REM:MODIFIED FOR CONTINUOUS PRESSURE SENSOR. PK-780216
3108 REM:MODIFICATION- ADD OF REFERENCE VOLTAGE RATIO (K0) INPUT
3110 REM:DATA ANALYSIS PROG WILL BE APPENDED HERE

```

Figure E-1. Listing for First File of CAPS Dropsonde Program, 8 June 1978 (Page 3 of 3)



```

3110 REM:THIS PROGRAM (FROM FILE 2) ASSIGNS FILE NOS. TO BE PROCESSED
3111 DELETE L
3112 DELETE 2991,3109
3113 DIM L(3,6)
3114 PRI *LOAD **SAFE** DATA CASSETTE INTO CONSOLE. ENTER FILE NOS. OF *
3116 PRINT *CALIBRATION AND DATA FILES TO BE PROCESSED (CC DD) -- *;
3118 INPUT Z9,Z8
3119 GO TO 4225
3120 REM:READ CAL FILE
3121 FIND Z9
3122 INPUT @33:D1,N0,T1,T2,P1,P2,S0,T3,R3,R4,L,K0
3123 GO TO 3260
3150 REM:LOOKING FOR DATA SPIKES
3151 IF A(N9)=0 OR C(N9)=0 THEN 3170
3152 IF A(N9)=>C(N9) THEN 3162
3154 L9=C(N9)/A(N9)
3156 L8=B(N9)/A(N9)
3158 L7=B(N9)/C(N9)
3160 GO TO 3168
3162 L9=A(N9)/C(N9)
3164 L8=A(N9)/B(N9)
3166 L7=C(N9)/B(N9)
3168 IF L8>L9*1.02 OR L7<1/L9/1.02 THEN 3174
3170 L9=1
3172 GO TO 3176
3174 L9=2
3176 RETURN
3260 PRINT *ENTER TIME INTERVAL (SEC.) FROM LAUNCH TO XMITTER ON -- *;
3262 INPUT T0
3264 PRI *FOR AUTOCOPY&PAGE, ENTER 1; AUTOPAGE ONLY, 2; NEITHER, 3 -- *;
3266 INPUT S9
3268 GO TO S9 OF 3274,3280,3286
3270 END
3272 REM:WRITTEN770415,LOADED770504,DEBUGGED770505,INTEGRATED770705 MCW
3274 REM:START HERE FOR AUTOCOPY&PAGE
3276 PRINT @32,26:3
3278 GO TO 3290
3280 REM:START HERE FOR AUTOPAGE
3282 PRINT @32,26:2
3284 GO TO 3290
3286 REM:START HERE FOR MANUAL COPY&PAGE
3288 PRINT @32,26:0
3290 REM:READ & UNPACK DATA FROM FILE
3292 DIM A(4),B(4),C(4),D(4)
3294 RESTORE 3298
3296 READ @34:T9,T8,T7,T6,A,B,C,D
3298 DATA 0,0,0,1,0,0,0,0,0,0,0,0,0,0,0,0,0,0,3.0E-5,3.0E-5,1.0E-3,2.0E-5
3300 REM:INITIALIZE FOR GETTING SIG PER RATIOS USING SIG LEV SUBRT
3302 DIM F(3,400),S(3,8)
3304 FOR I9=1 TO 3
3306 FOR I8=1 TO 400
3308 F(I9,I8)=0
3310 NEXT I8

```

Figure E-2. Listing for Second File of CAPS Dropsonde Program, 8 June 1978 (Page 1 of 8)



```

3312 NEXT I9
3314 RESTORE 3318
3316 READ @34:P(1,400),P(2,400),P(3,400),S
3318 DATA 0,0,0,0.007,0,-9.9E+99,9.9E+99,0,0,0,0,0.007,0,-9.9E+99
3320 DATA 9.9E+99,0,0,0,0,0.008,0,-9.9E+99,9.9E+99,0,0,0,0
3322 PRINT *SELECT DATA SOURCE: 1=PACKED FILE, 2=REDUCED FILE -- *;
3324 INPUT S9
3326 GO TO S9 OF 3346,3330
3328 STOP
3330 PRINT *PUT**SAFE**CASS (FILE 23=P ARRAY) IN 4051. ENT R WN RDY - *;
3332 INPUT S$
3334 IF S$="R" THEN 3338
3336 GO TO 3330
3338 DIM P(3,400)
3340 FIND 23
3342 READ @33:P
3343 PRINT *CK & CORRECT P(M,N), THEN **RUN(LINE # AFTER STOP)**.*
3344 STOP
3345 GO TO 3382
3346 FIND Z8
3348 READ @33:Z7
3350 Z6=0
3352 Z6=Z6+1
3354 READ @33:Z0
3356 GO TO 3360
3358 PRINT @41:Z6,Z0;
3360 REM:UNPACK FIRST HALF Z0 TO GET PERIOD Z1
3362 Z1=INT(Z0)/1.0E+8
3364 REM:PROCESS UNPACKED VALUE
3366 GOSUB 3384
3368 REM:UNPACK & PROCESS SECOND PERIOD
3370 Z1=(Z0-INT(Z0))/100
3372 GOSUB 3384
3374 REM:WAS THIS WORD THE LAST IN FILE?
3375 REM:SEV SEC PRE-LAUNCH DATA MUST BE IN PACK FILE FOR SURF VALUE
3376 IF Z6=Z7 THEN 3378
3377 GO TO 3352
3378 T9=T9+4
3379 A=0
3380 GOSUB 3498
3381 PRINT *LAST ENTRY HAS BEEN READ FROM PACKED DATA FILE*
3382 GO TO 3975
3383 GO TO 4195
3384 REM:TESTING & MAINTAINING SYNC
3385 REM:T9 SAMPS ENTERED STACK SINCE LAUNCH. T8=LAST REF TAG
3386 IF T9=0 THEN 3512
3388 GO TO T6 OF 3396,3406,3406,3466
3390 LIST 3388
3392 PRINT *T6=";T6
3394 STOP
3396 REM:CYCLE SHIFT
3398 A0=A(4)

```

Figure E-2. Listing for Second File of CAPS Dropsonde Program, 8 June 1978 (Page 2 of 8)



```

3400 A=B
3402 B=C
3404 T9=T9+4
3406 IF Z1>1/L1 AND Z1<1/L0 THEN 3440
3408 IF Z1=>1/L2 AND Z1<=1/L1 THEN 3416
3410 REM:Z1 NOT DATA AND NOT REF. APPLY NON-VALID TAG (.1)
3412 Z1=0.1+Z1
3414 GO TO 3440
3416 GO TO T6 OF 3420,3426,3432,3418
3418 STOP
3420 C(1)=0.99999
3422 T6=T6+1
3424 T7=T7+1
3426 C(2)=0.99999
3428 T6=T6+1
3430 T7=T7+1
3432 C(3)=0.99999
3434 T6=T6+1
3436 T7=T7+1
3438 GO TO 3384
3440 GO TO T6 OF 3448,3454,3460,3466
3442 LIST 3440
3444 PRINT 'T6=';T6
3446 STOP
3448 C(1)=Z1
3450 T6=2
3452 GO TO 3592
3454 C(2)=Z1
3456 T6=3
3458 GO TO 3592
3460 C(3)=Z1
3462 T6=4
3464 GO TO 3592
3466 IF Z1=>1/L2 AND Z1<=1/L1 THEN 3482
3468 REM:REF EXPECTED BUT MISSING; ADD SYNC-LOSS TAG .99 TO DDDR SAMPS
3476 C(4)=Z1
3478 C=0.99+C
3479 GO TO 3484
3482 T8=T9+T7
3483 C(4)=Z1
3484 T6=1
3485 PRINT 'T9,T7,T8=',T9,T7,T8
3486 PRINT 'B=';T9+T7-7+B(1),T9+T7-6+B(2),T9+T7-5+B(3),T9+T7-4+B(4)
3488 REM:RESTORE CYCLE IN ARRAY B, IF NEEDED
3490 GOSUB 3594
3492 REM:CALCULATE PERIOD RATIOS IN ARRAY A
3494 GOSUB 3664
3496 PRINT @41:A(1),A(2),A(3),T9+T7-8+A(4)
3498 REM:SCAN ARRAY A & DETECT SIG RATIOS
3500 FOR N8=1 TO 3
3502 P9=N8+A(N8)

```

Figure E-2. Listing for Second File of CAPS Dropsonde Program, 8 June 1978 (Page 3 of 8)



```

3504 N9=T9+T7-12+N8
3506 GOSUB 3695
3508 NEXT N8
3510 GO TO 3592
3512 REM:LOOKING FOR FIRST SYNCHRONIZED CYCLE
3514 GO TO T6 OF 3516,3522,3522,3522,3532
3516 REM:IS Z1 A REF SIGNAL?
3518 IF Z1=>1/L2 AND Z1<=1/L1 THEN 3536
3520 GO TO 3588
3522 REM:IS Z1 A DATA SIGNAL?
3524 IF Z1>1/L1 AND Z1<=1/L0 THEN 3542
3526 PRINT "FALSE START. T6=";T6
3528 T6=1
3530 GO TO 3512
3532 IF Z1=>1/L2 AND Z1<=1/L1 THEN 3566
3534 GO TO 3526
3536 T6=2
3538 B(4)=Z1
3540 GO TO 3588
3542 GO TO T6 OF 3544,3548,3554,3560,3544
3544 LIST 3542
3546 STOP
3548 T6=3
3550 C(1)=Z1
3552 GO TO 3588
3554 T6=4
3556 C(2)=Z1
3558 GO TO 3588
3560 T6=5
3562 C(3)=Z1
3564 GO TO 3588
3566 REM:T9 IS NO. OF SAMPS TO "ENTER" STACK SINCE LAUNCH
3568 T9=T0*10+8
3569 T8=T9
3570 T6=1
3572 C(4)=Z1
3574 PRINT Z6+T7+Z1
3576 PRINT
3578 PRINT "LAST 5 SAMPS ARE FIRST CYCLE PASSING RDDDR RANGE TEST"
3580 PRINT
3582 PRINT "REF STARTING 1ST SYNC CYCLE (TIME-TAG + PER): ";T9-4+B(4)
3584 PRINT "FOLLOWING SAMPS ARE OUTPUT FROM SYNC TEST & MAINTENANCE"
3586 GO TO 3592
3588 REM:PRINT FILE ENTRY NO.(Z6) & PERIOD
3590 PRINT Z6+T7+Z1;" ";
3592 RETURN
3594 REM:VALIDATE DATA IN ARRAY C USING LIMITS IN D
3596 FOR N9=1 TO 4
3598 GO TO N9 OF 3606,3600,3604,3606
3600 D(2)=400*D(2)
3602 GO TO 3606
3604 D(2)=D(2)/400

```

Figure E-2. Listing for Second File of CAPS Dropsonde Program, 8 June 1978 (Page 4 of 8)



```

3606 IF ABS(A(N9)-C(N9))<D(N9) OR ABS(B(N9)-C(N9))<D(N9) THEN 3610
3608 PRINT 'C(';N9;') FAILS VAL TEST.TIME-TAGGED PER.=';T9+T7-4+N9+C(N9)
3610 NEXT N9
3612 REM:RESTORE DATA IN ARRAY B
3613 N8=0
3614 FOR N9=1 TO 4
3615 IF N9<3 THEN 3619
3616 IF A(N9)/B(N9)<1.02 AND A(N9)/B(N9)>0.980392 THEN 3642
3617 GOSUB 3150
3618 GO TO L9 OF 3642,3628
3619 IF ABS(A(N9)-B(N9))<D(N9) THEN 3642
3620 REM:B(N9)NOT OK. CAN C(N9) BE USED TO RESTORE?
3622 IF ABS(A(N9)-C(N9))<D(N9) THEN 3628
3624 REM:C(N9) NOT OK FOR RESTORATION
3626 GO TO 3642
3628 REM:RESTORE B(N9)
3630 PRINT
3632 PRINT 'RESTORED PACK-WORD';Z6-1; FROM ';T9+T7-8+N9+B(N9);'TO ';
3634 B(N9)=(A(N9)+C(N9))/2
3636 PRINT T9+T7-8+N9+B(N9)
3638 PRINT
3640 GO TO 3646
3642 REM:NO RESTORATION. INCREMENT COUNT OF NON-RESTORED SAMPS (N8)
3644 N8=N8+1
3646 NEXT N9
3648 IF N8<4 THEN 3652
3650 GO TO 3660
3652 PRINT
3654 PRINT 'RESTORED CYCLE FOLLOWS:'
3656 PRINT T9+T7-7+B(1),T9+T7-6+B(2),T9+T7-5+B(3),T9+T7-4+B(4)
3658 PRINT
3660 N8=0
3662 RETURN
3664 REM:CALCULATE PERIOD RATIOS IN ARRAY A
3666 IF A(1)=0 AND A(2)=0 AND A(3)=0 THEN 3690
3668 IF A0=>1/L2 AND A0<=1/L1 AND ABS(A0-A(4))<D(4) THEN 3676
3669 C(1)=0.999
3670 C(2)=0.999
3671 C(3)=0.999
3672 PRINT @41:'TAGS ';T9+T7-13; '&';T9+T7-9;' FAIL REF COMP;ADD .999'
3674 GO TO 3690
3676 FOR N9=1 TO 3
3678 IF A(N9)<1/L0 THEN 3686
3680 LIST 3678
3682 PRINT 'A(N9)= ';A(N9)
3686 A(N9)=(A0*(4-N9)+A(4)*N9)/(4*A(N9))
3688 NEXT N9
3690 RETURN
3695 REM:THIS SBRT MODIFIED TO MAKE ENTIRE LEVEL SIG IF ANY
3700 REM:ON THAT LEVEL ARE SIG- PK-780310
3705 REM:INPUT IS ID-TAGGED PERIOD RATIO P9 AT TIME N9 (SAMPLE NO.)
3710 REM:INPUT TOLERANCES ARE S(M,1)
3715 REM:OUTPUTS ARE TIME-TAGGED SIGNIFICANT LEVELS P(M,N)
3720 REM:P(M,400) IS NO. OF SIGNIF LEVS STORED

```

Figure E-2. Listing for Second File of CAPS Dropsonde  
Program, 8 June 1978 (Page 5 of 8)



```

3980 REM:DATA CONTINUITY TESTING AND RESTORATION
3985 REM:E9=RATIO RATE LIMIT, E8=TEMP RATE LIM, E7=PRES LIM E6=HUM LIM,
3990 REM:E5=RATIO RATE, E4=THIS TAG-RATIO, E3=POINTER TO LAST CON RATIO
3995 PRINT 'TO LIST PER. RATIOS BEFOR GAP PROC'G, ENTR '**+' -- ';
4000 INPUT S$
4005 IF S$<>'+' THEN 4030
4010 PRINT @41:'TIME-TAGGED PERIOD RATIOS BEFORE GAP PROCESSING'
4015 PRINT @41:F
4020 PRINT 'CK DATA LIST & MAKE NEEDED CHANGES BEFOR CONTINUING RUN'
4025 STOP
4030 DIM P(3,400),R(3)
4035 RESTORE 4045
4037 REM:E8,E7,E6 ARE ALLOWED T,F,H TRENDS- RAT OF RAT PER FRAME
4038 REM:R IS # OF T-TAGS OF TREND = NOISE
4040 READ @34:E8,E7,E6,R
4045 DATA 1.003,1.003,1.32,14,14,3.3
4050 FOR M=1 TO 3
4055 PRINT ' ', 'START M=';M
4060 GO TO M OF 4065,4075,4085
4065 E9=E8
4070 GO TO 4090
4075 E9=E7
4080 GO TO 4090
4085 E9=E6
4090 REM:FIND FIRST RATIO IN EXPECTED RANGE
4095 N=1
4100 E3=P(M,N)
4105 IF E3-INT(E3)>0.1 AND E3-INT(E3)<0.95 THEN 4120
4110 N=N+1
4115 GO TO 4100
4120 E3=N
4125 N=N+1
4130 E4=P(M,N)
4135 E5=(E4-INT(E4))/(P(M,E3)-INT(P(M,E3)))
4140 E5=E5^(4/(INT(E4)-INT(P(M,E3))+R(M)))
4145 IF E5<E9 AND E5>1/E9 THEN 4290
4147 GO TO 4150
4148 PRINT @41:'INVALID SAMPLE - ';E4
4150 REM:RATIO CHANGE IS EXCESSIVE. FIND NEXT RATIO WITHIN CHANGE LIMIT
4155 PRINT ' ', 'E5=';E5
4160 S9=INT(P(1,P(1,400)))
4165 Z9=INT(P(3,P(3,400)))
4170 IF M=3 AND INT(E4)>S9 AND Z9-INT(E4)<20 THEN 4180
4175 GO TO 4190
4180 PRINT 'BAD HUM PAST TEMP END & WITHIN 2 SEC OF HUM END'
4185 GO TO 4245
4190 IF N<P(M,400) THEN 4375
4195 REM: TRAP AFTER STATEMENT 3120
4200 PRINT 'LOOK AT P(M,400)'S, ARE THEY OK'
4205 STOP
4210 GO TO 3122
4215 PRINT 'REACHED END OF FILE P(';M;'N). LAST OK SAMP=';P(M,E3)

```

Figure E-2. Listing for Second File of CAPS Dropsonde Program, 8 June 1978 (Page 7 of 8)



```

3725 M=INT(P9)
3730 REM:CALCULATE NEW SLOPE S(M,5)
3735 S(M,5)=(P9-INT(P9)-(S(M,2)-INT(S(M,2))))/(N9-INT(S(M,2)))
3740 REM:TEST NEW SLOPE
3745 IF S(M,5)>S(M,3) AND S(M,5)<=S(M,4) THEN 3825
3750 FOR M9=1 TO M
3755 IF P(M9,P(M9,400)+1)<>0 THEN 3815
3760 REM:NEW SLOPE N.G.; STORE SIGNIFICANT & LAST VALUE ; EXPAND LIMITS
3765 S(M9,2)=S(M9,8)
3770 IF P(M9,400)<399 THEN 3790
3775 LIST 3770
3780 STOP
3790 PRINT @41: " ", " ", " ", " ", " " M=";M9;" S.L.=";S(M9,2)
3795 P(M9,P(M9,400)+1)=S(M9,2)
3805 S(M9,3)=-9.0E+99
3810 S(M9,4)=9.0E+99
3815 NEXT M9
3820 GO TO M OF 3970,3970,3832
3825 IF P(1,P(1,400)+1)<>0 THEN 3750
3830 IF M=3 THEN 3835
3831 GO TO 3970
3832 FOR M9=1 TO 3
3833 P(M9,400)=P(M9,400)+1
3834 NEXT M9
3835 FOR M9=1 TO 3
3840 REM:NEW SLOPE O.K.; SHRINK ACCEPTANCE SLOPE LIMITS IF NEEDED
3845 IF N9>INT(S(M9,2)) THEN 3875
3850 S(M9,6)=A(M9)-INT(A(M9))+S(M9,1)-(S(M9,2)-INT(S(M9,2)))
3855 S(M9,6)=S(M9,6)/(N9+M9-3-INT(S(M9,2)))
3860 S(M9,7)=A(M9)-INT(A(M9))-S(M9,1)-(S(M9,2)-INT(S(M9,2)))
3865 S(M9,7)=S(M9,7)/(N9+M9-3-INT(S(M9,2)))
3870 GO TO 3895
3875 S(M9,6)=A(M9)-INT(A(M9))-S(M9,1)-(S(M9,2)-INT(S(M9,2)))
3880 S(M9,6)=S(M9,6)/(N9+M9-3-INT(S(M9,2)))
3885 S(M9,7)=A(M9)-INT(A(M9))+S(M9,1)-(S(M9,2)-INT(S(M9,2)))
3890 S(M9,7)=S(M9,7)/(N9+M9-3-INT(S(M9,2)))
3895 REM:TEST MIN SLOPE
3900 IF S(M9,6)>S(M9,3) THEN 3915
3905 REM:MIN ACCEPTABLE SLOPE OK AS IS
3910 GO TO 3925
3915 REM:UPDATE MIN ACCEPTABLE SLOPE
3920 S(M9,3)=S(M9,6)
3925 REM:TEST MAX SLOPE
3930 IF S(M9,7)<S(M9,4) THEN 3945
3935 REM:MAX ACCEPTABLE SLOPE O.K. AS IS
3940 GO TO 3955
3945 REM:UPDATE MAX ACCEPTABLE SLOPE
3950 S(M9,4)=S(M9,7)
3955 REM:ACCEPTANCE SLOPE LIMITS UPDATED; NOW UPDATE LAST LEVEL
3960 S(M9,8)=N9+M9-3+(A(M9)-INT(A(M9)))
3965 NEXT M9
3970 RETURN
3975 REM:ARRAY OF SIGNIFICANT PERIOD RATIOS HAS BEEN BUILT.

```

Figure E-2. Listing for Second File of CAPS Dropsonde Program, 8 June 1978 (Page 6 of 8)



```

4220 GO TO 4245
4225 LO=200
4230 L1=1925
4235 L2=1975
4240 GO TO 3120
4245 PRINT 'FOLLOWING SAMPS BEING DELETED:'
4250 N=E3
4255 N=N+1
4260 PRINT ' ', ' ', P(M,N)
4265 P(M,N)=0
4270 IF N=P(M,400) THEN 4280
4275 GO TO 4255
4280 P(M,400)=E3
4285 GO TO 4375
4290 REM:RATIO CHANGE IS WITHIN EXPECTED LIMITS
4292 REM:IS DATA TAGGED 'NO GOOD'
4293 IF E4-INT(E4)>0.99 OR E4-INT(E4)<0.05 THEN 4148
4295 IF E3=N-1 THEN 4370
4300 IF INT(E4)-INT(P(M,E3))<21 THEN 4320
4305 LIST 4300
4310 PRINT 'DATA GAP EXCEEDS 2 SEC. SHOULD IT BE RESTORED?'
4315 STOP
4320 PRINT 'DATA GAP <2 SEC BEING RESTORED'
4325 PRINT 'PRE-GAP VALUE =';P(M,E3)
4330 E3=E3+1
4335 PRINT 'P(';M;',';E3;') CHANGED FROM ';P(M,E3);' TO ';
4340 E2=E5^(((INT(P(M,E3))-INT(P(M,E3-1)))/10)
4345 P(M,E3)=INT(P(M,E3))+P(M,E3-1)-INT(P(M,E3-1))*E2
4350 PRINT P(M,E3)
4355 IF E3=N-1 THEN 4365
4360 GO TO 4330
4365 PRINT 'POST-GAP RATIO = ';P(M,N)
4370 E3=N
4375 IF N=>P(M,400) THEN 4385
4380 GO TO 4125
4385 PRINT ' ', 'END M=';M
4390 NEXT M
4395 PRINT 'TO LIST PER. RATIOS AFTER GAP PROC'G, ENTR '+'' -- ';
4400 INPUT S$
4405 IF S$<>'+' THEN 4420
4407 PRINT @41:
4410 PRINT @41:'PERIOD RATIOS AFTER GAP PROCESSING'
4415 PRINT @41:P
4420 STOP
4425 REM:NOW IMPORT SOFTWARE FOR PROCESSING DATA FROM ARRAY.
4430 PRI 'LOAD ''SAFE'' PROG CASS IN INTERNL UNIT. ENTR R WEN R0Y -- ';
4435 INPUT S$
4440 IF S$='R' THEN 4450
4445 GO TO 4430
4450 FIND 3
4455 DELETE 100,4445
4460 APPEND 4750
4750 REM:PROG FILE 3 GETS APPENDED HERE

```

Figure E-2. Listing for Second File of CAPS Dropsonde  
Program, 8 June 1978 (Page 8 of 8)



```

4750 REM:THIS PROG FROM FILE 3 APPENDS TO END OF PROG FROM FILE 2
4752 REM:ANALYZE DATA FROM INTERNAL FILE
4754 DELETE 100,4749
4756 PRINT 'SELECT APP HUM SBRT(1=INTERP,2=EQN) -- ';
4758 INPUT FO
4760 REM:CALCULATE MB PRESSURE (Q9) AT LAUNCH ALT
4762 REM:INPUTS- PRESSURE ALT P1 (KFT), SURFACE PRESSURE P2 (MB)
4763 GO TO 4770
4764 Q9=(P2^0.190263-0.0256553*P1)^5.255883
4766 PRINT 'CALC PRES FROM ALT= ';Q9;' MB'
4768 PRINT @41:'CALC PRES FROM ALT= ';Q9;' MB'
4770 PRINT 'OPR-ENTERED EST OF SURF PRES= ';P2;' MB'
4772 PRINT @41:'OPR-ENTERED EST OF SURF PRES= ';P2;' MB'
4774 PRINT 'ENTER EST OF VOLT REG TEMP T4 -- ';
4776 INPUT T4
4778 PRINT @41:'T4 = ';T4;' DEG C'
4779 GO TO 8530
5500 REM:CALCULATE TEMPS. T9=RES RATIO, T8=THIS APPARENT TEMP, T7=LAST
5502 REM:APP TEMP, T6=THIS TIME, T5=LAST TIME
5503 PRINT 'STARTING TEMP CALCS'
5504 GO TO 5522
5505 REM:LAG COMP BEING SKIPPED FOR NOW
5506 REM:J0 & J1 ARE LAG COMP FACTORS FOR TEMP & HUM RANGING 0 TO 1
5508 RESTORE 5509
5509 DATA -99,0,0
5510 READ @34:T9,J0,J1
5511 PRINT 'COMPS SET AT T: ';J0;' & H: ';J1;' WANT CHANGE? (1+/2-) - ';
5513 INPUT Z9
5514 GO TO Z9 OF 5516,5520
5515 GO TO 5511
5516 PRINT 'ENTR COMP SETTINGS IN RANGE 0-1 (NONE-FULL) (T.TT H.HH)- ';
5517 INPUT J0,J1
5518 GO TO 5511
5520 PRINT @41:' LAG-COMP LEVELS ARE SET TO T: ';J0;' & H: ';J1
5522 FOR N=1 TO P(1,400)
5523 T9=P(1,N)-INT(P(1,N))
5525 T6=INT(P(1,N))
5530 IF T9>0.1 THEN 5560
5550 GO TO 5640
5560 REM:CALCULATE RES RATIO
5562 REM: WILL BYPASS THER RES RATIO CALC FOR BAROSWITCH DROPSONDE
5563 GO TO 5568
5565 T9=(52.718/T9-47.718)/R3
5568 T9=22.1*(1/(K0*T9)-1)/R3
5570 REM:CALCULATE APPARENT TEMP
5575 T8=65.3/(1-SQR(1-0.0480921*LOG(T9/3.3785E-4)))-273.16
5580 P(1,N)=INT(P(1,N))+T8/1000+0.1
5584 GO TO 5590
5585 PRINT 'TIME-TAGGED APPARENT TEMP(MILLIDEG C)=';P(1,N)
5590 IF T7>-70 THEN 5615
5600 LIST 5590

```

Figure E-3. Listing for Third File of CAPS Dropsonde Program, 8 June 1978 (Page 1 of 8)



```

5610 STOP
5615 GO TO 5670
5620 REM:LAG-COMP OF TEMP; J0=COMP-LEVEL SETTING (0-1: NONE-FULL)
5630 Z9=INT((T6+T5)/2+0.5)
5632 P(1,N-1)=Z9+0.1+1.0E-3*((T8+T7)/2+(T8-T7)/(T6-T5)*20*J0)
5634 GO TO 5640
5635 PRINT "TAG:";INT(P(1,N)),"LC TEMP:";(P(1,N)-INT(P(1,N))-0.1)*1000
5637 PRINT 1000*(P(1,N-1)-INT(P(1,N-1))-0.1)
5640 T7=T8
5650 T5=T6
5670 NEXT N
5671 GO TO 5700
5672 P(1,P(1,400))=0
5674 P(1,400)=P(1,400)-1
5680 PRINT "END"
5690 STOP
5700 PRINT "STARTING PRES CALCS"
5705 REM: OVERLAY P(2,N) ARRAY WITH PRES VALUES
5710 D7=1
5720 FOR N=1 TO P(2,400)
5730 D9=INT(P(1,N))
5740 D8=(P(1,N)-0.1-D9)*1000
5745 IF D8=999 THEN 5764
5750 GOSUB 8750
5760 P(2,N)=D9+1+P5/10000
5763 GO TO 5765
5764 P(2,N)=INT(P(2,N))+0.9999
5765 NEXT N
5770 PRINT "END OF PRES CALC"
6000 REM:OVERLAY P(3,N) ARRAY WITH COMP HUM VALUES.
6020 REM:C9=LAST APP HUM, C8=LAST APP HUM TIME-TAG, C7=MEAN APP HUM
6040 REM:C3=MEAN TAG, C5= APP HUM RATE, C4=THIS APP HUM TIME TAG
6050 PRINT "STARTING HUM CALCS"
6060 RESTORE 6100
6080 READ @34:C9,D7
6100 DATA 999,1
6160 FOR N=1 TO P(3,400)
6180 REM:CALC HUML RES RATIO R8
6200 R8=P(3,N)-INT(P(3,N))
6209 PRINT "PER RATIO = ";R8;
6210 IF R8=0 THEN 6860
6215 REM: WILL BYPASS HUML RES RATIO CALC FOR BAROSWITCH DROPSONDE
6217 GO TO 6235
6220 R8=52.718/R8-47.718-7.1
6230 R8=250*R8/(250-R8)/R4
6235 R8=249*(18.2-R8*K0*25.35)/(K0*R8*274.35-18.2)/R4
6239 PRINT " RES RATIO=";R8
6240 REM:FETCH CORRESPONDING COMP TEMP T6 FOR APP HUM CALC
6260 C4=INT(P(3,N))
6270 D9=C4-2
6279 PRINT "TIME TAG= ";C4;

```

Figure E-3. Listing for Third File of CAPS Dropsonde Program, 8 June 1978 (Page 2 of 8)



```

6280 D8=(P(1,N)-0.1-D9)*1000
6281 PRINT '    TEMP=";D8;
6300 T6=D8
6320 REM:CALC APP HUM
6330 GO TO F0 OF 6340,6350
6332 LIST 6330
6335 STOP
6340 GOSUB 8000
6345 GO TO 6357
6350 GOSUB 8600
6355 PRINT '    APP H=";H9
6357 GO TO 6845
6360 IF C9>101 OR H9=999 THEN 6370
6365 GO TO 6380
6370 IF N<=1 THEN 6800
6375 P(3,N-1)=INT(P(3,N-1))+0.999
6377 GO TO 6800
6380 REM:CAL MEAN AP HUM C7, MEAN-TAG TEMP C6 & HUM RATE C5 FOR HUM SEG
6400 C7=(H9+C9)/2
6420 C3=INT((C4+C8)/2+0.5)
6440 C5=(H9-C9)/(C4-C8)*10
6460 REM:FETCH COMP TEMP C6 FOR TIME-TAG C3
6480 D9=C3
6499 PRINT 'TIME=";D9/10;
6500 GOSUB 7000
6501 PRINT '    TEMP=";D8;
6502 IF D8<>999 THEN 6520
6504 IF C3-INT(P(1,P(1,400)))>0 AND C3-INT(P(1,P(1,400)))<=4 THEN 6510
6506 GO TO 6520
6510 PRINT 'TAG IS WITHIN 4 SEC OF TEMP END. LAST TEMP WILL BE USED'
6512 D8=C6
6514 PRINT '    TEMP=";D8
6520 C6=D8
6540 GOSUB 9000
6541 PRINT '    ', 'COMP H=";G6
6545 IF G6<=100 THEN 6560
6549 LIST 6545
6550 PRINT 'COMP HUM CHANGED FROM ";G6;" TO 100; TIME TAG= ";C6
6560 P(3,N-1)=C3+1.0E-3*(G6 MIN 100)
6800 REM:SET-UP FOR PROCESSING NEXT N
6820 C9=H9
6840 C8=C4
6845 REM:WRITE BALLOON HUM
6850 P(3,N)=D9+2+H9/1000
6860 NEXT N
6870 GO TO 6940
6880 P(3,P(3,400))=0
6900 P(3,400)=P(3,400)-1
6920 PRI 'COMP HUM VALUES HAVE BEEN STORED IN REDUCED DATA FILE P(3,N)'
6940 PRINT @41:P
6960 GO TO 9100

```

Figure E-3. Listing for Third File of CAPS Dropsonde Program, 8 June 1978 (Page 3 of 8)



```

7000 REM:APPEND TEMP-FETCH HERE
7020 REM:FETCH COMP-TEMP D8 FOR TIMETAG D9 USING POINTER D7
7021 GO TO 7040
7022 IF INT(F(1,1))<=D9 AND INT(F(1,F(1,400)))>=D9 THEN 7040
7024 PRINT 'TIME-TAG D9 (';D9;) IS OUTSIDE LIMITS OF REDUCED TEMP DATA'
7026 D8=999
7028 GO TO 7360
7040 IF D7=>1 AND D7<=F(1,400) THEN 7080
7050 IF D7<>0 THEN 7080
7060 D8=999
7070 GO TO 7360
7080 D8=INT(F(1,D7))
7100 IF D8<>D9 THEN 7160
7120 D8=1000*(F(1,D7)-0.1-D8)
7140 GO TO 7360
7160 IF D8<D9 THEN 7220
7180 D7=D7-1
7200 GO TO 7040
7220 D7=D7+1
7240 D8=INT(F(1,D7))
7260 IF D8=D9 THEN 7120
7280 IF D8>D9 THEN 7320
7300 GO TO 7220
7320 D8=(D9-INT(F(1,D7-1)))/(D8-INT(F(1,D7-1)))
7340 D8=D8*(F(1,D7)-INT(F(1,D7))-(F(1,D7-1)-INT(F(1,D7-1))))
7350 D8=1000*(F(1,D7-1)-INT(F(1,D7-1))-0.1+D8)
7360 RETURN
8000 REM:CALC %RH-INPUT COMP TEMP T6 & HUML RATIO R8; OUTPUT %RH H9
8001 IF T6<>999 THEN 8005
8002 H9=999
8003 GO TO 8515
8005 DATA 0.52,0.62,0.74,0.82,0.9,1.1,1.3,1.63,2.23
8010 DATA 3.1,4.2,6.5,10.2,17,29,45,45,45,45,45
8015 DATA 0.55,0.65,0.78,0.85,0.92,1.06,1.23,1.4,1.75
8020 DATA 2.35,3.1,4.1,6,9.8,17,26,44,86,170,250
8025 DATA 0.585,0.695,0.8,0.875,0.94,1.05,1.175,1.32,1.58
8030 DATA 2,2.5,3.25,4.5,7.3,12,18.5,29,60,140,220
8035 DATA 0.61,0.72,0.82,0.89,0.95,1.04,1.15,1.27,1.47
8040 DATA 1.85,2.3,3,4,6.4,10,16,23,40,126,206
8045 H1=0
8050 H2=0
8055 H3=0
8060 H4=0
8065 IF T6=>-40 AND T6<0 THEN 8075
8070 GO TO 8090
8075 RESTORE 8005
8080 H1=999
8085 GOSUB 8290
8090 IF T6=>-40 AND T6<25 THEN 8100
8095 GO TO 8115
8100 RESTORE 8015

```

Figure E-3. Listing for Third File of CAPS Dropsonde Program, 8 June 1978 (Page 4 of 8)



```

8105 H2=999
8110 GOSUB 8290
8115 IF T6>0 AND T6<40 THEN 8125
8120 GO TO 8140
8125 RESTORE 8025
8130 H3=999
8135 GOSUB 8290
8140 IF T6>25 AND T6<=40 THEN 8150
8145 GO TO 8165
8150 RESTORE 8035
8155 H4=999
8160 GOSUB 8290
8165 IF T6<-40 OR T6>40 THEN 8175
8170 GO TO 8190
8175 LIST 8165
8180 PRINT 'T6= ';T6,' - TILT!!! TEMP EXCEEDS HYG RATIO LIMITS'
8181 PRINT 'WILL SET H9=999 & RETURN'
8182 GO TO 8002
8185 STOP
8190 REM:TEMP INTERPOLATION OF RH BEGINS HERE
8195 IF H1>0 AND H2=0 AND H3=0 AND H4=0 THEN 8455
8200 IF H1=0 AND H2>0 AND H3=0 AND H4=0 THEN 8465
8205 IF H1=0 AND H2=0 AND H3>0 AND H4=0 THEN 8475
8210 IF H1=0 AND H2=0 AND H3=0 AND H4>0 THEN 8485
8215 IF H1>0 AND H2>0 AND H3=0 AND H4=0 THEN 8225
8220 GO TO 8235
8225 H9=H1+(H2-H1)*(T6+40)/40
8230 GO TO 8495
8235 IF H1=0 AND H2>0 AND H3>0 AND H4=0 THEN 8245
8240 GO TO 8255
8245 H9=H2+(H3-H2)*T6/25
8250 GO TO 8495
8255 IF H1=0 AND H2=0 AND H3>0 AND H4>0 THEN 8265
8260 GO TO 8275
8265 H9=H3+(H4-H3)*(T6-25)/15
8270 GO TO 8495
8275 LIST 8255
8280 PRINT 'PROGRAMMED STOP'
8285 STOP
8290 REM:INTERPOLATE RATIO TO GET HUM; PUT HUM IN PLACE OF 999 VALUE
8295 H7=5
8300 READ @34:H8
8305 IF R8=>H8 THEN 8320
8310 H5=9.9
8315 GO TO 8370
8320 H7=H7+5
8325 IF H7<=105 THEN 8345
8330 LIST 8325
8335 PRINT 'HYGR RATIO EXCEEDS LIMITS, (=';R8;')'
8340 GO TO 8002
8345 H6=H8

```

Figure E-3. Listing for Third File of CAPS Dropsonde Program, 8 June 1978 (Page 5 of 8)



```

8350 READ @34:H8
8355 IF R8>H8 THEN 8320
8360 REM:R8 IS IN RANGE OF H6 - H8; WILL INTERPOLATE RATIO TO GET HUM
8365 H5=H7+5*(R8-H6)/(H8-H6)
8370 REM:REPLACE999 WITH H5 THEN RETURN
8375 IF H1=999 AND H2<106 AND H3<106 AND H4<106 THEN 8410
8380 IF H1<106 AND H2=999 AND H3<106 AND H4<106 THEN 8420
8385 IF H1<106 AND H2<106 AND H3=999 AND H4<106 THEN 8430
8390 IF H1<106 AND H2<106 AND H3<106 AND H4=999 THEN 8440
8395 LIST 8390
8400 PRINT "PROGRAMMED STOP"
8405 STOP
8410 H1=H5
8415 GO TO 8450
8420 H2=H5
8425 GO TO 8450
8430 H3=H5
8435 GO TO 8450
8440 H4=H5
8445 GO TO 8450
8450 RETURN
8455 H9=H1
8460 GO TO 8495
8465 H9=H2
8470 GO TO 8495
8475 H9=H3
8480 GO TO 8495
8485 H9=H4
8490 GO TO 8495
8495 IF H9<=100 THEN 8515
8500 PRINT "APP HUM CHANGED FROM ";H9;" TO 100; TIME-TAG=";INT(P(3,N))
8505 H9=100
8510 REM:THIS PROG MODIFIED, DEBUGGED & WORKING AT SBRT LEVEL. MCW770809
8515 RETURN
8530 PRINT "SEL CALC MODE(1=CALC & DISP T,P,H; 2=CALC ALL T,P,H) ";
8532 INPUT F1
8534 IF F1=2 THEN 5500
8536 PRINT "SELECT TIME TAG (MUST BE =< MAX TIME TAG-2)";
8538 INPUT D9
8540 REM: SBRT WILL RETRIEVE TEM PER RAT D8 OF SPEC TIME TAG
8542 D7=1
8544 GOSUB 7000
8545 D8=D8/1000+0.1
8546 T9=22.1*(1/(K0*D8)-1)/R3
8548 T8=65.3/(1-SQR(1-0.0480921*LOG(T9/3.3785E-4)))-273.16
8550 D8=T8
8551 N=D7
8552 GOSUB 8750
8554 R8=P(3,N)-INT(P(3,N))
8556 R8=249*(18.2-R8*K0*25.35)/(K0*R8*274.35-18.2)/R4
8558 T6=T8

```

Figure E-3. Listing for Third File of CAPS Dropsonde Program, 8 June 1978 (Page 6 of 8)



```

8560 GOSUB 8600
8562 PRINT 'TIME TAG, TEMP, PRES, HUM= ';D9;' ';T8;' ';P5;' ';H9
8564 PRINT @41:'TIME TAG, TEMP, PRES, HUM= ';D9;' ';T8;' ';P5;' ';H9
8566 PRINT @41:'PRES COEF L(3,6) ARE AS FOLLOWS:'
8568 PRINT @41:L
8570 GO TO 8530
8600 REM: CALC APP HUM H9 FROM HUML RATIO R8 AND TEMP T6 DEG C.
8605 IF R8=>1 THEN 8625
8610 GOSUB 8640
8615 H9=33-H0
8620 GO TO 8700
8625 GOSUB 8660
8630 H9=33+H0
8635 GO TO 8700
8640 REM: ENTRY POINT FOR R8<1
8645 B9=20
8650 R9=1/R8
8655 GO TO 8675
8660 REM: ENTRY POINT FOR R8=>1
8665 B9=15
8670 R9=R8
8675 A9=0.02*T6+3.2
8680 K9=0.9-(0.001425*T6+0.25)*LGT(LGT(R9)+1)^0.33333333333333
8685 H0=A9*LOG(R9^B9)^K9
8690 RETURN
8695 REM: THIS SBRT TESTED & DEBUGGED 780213 PK-MCW
8700 RETURN
8750 REM: CALC PRES
8760 REM: INPUTS-K0=REF CONST, P(2,N)=PRES PER RAT, D8=COM TEMP
8770 REM: INPUTS-COEF IN L ARRAY
8780 REM: OUTPUT-PRES P5 (MB)
8790 REM: CALC SUPPLY VOLTS V0
8800 V0=7.629+0.0076*T4
8810 G0=L(1,1)+L(1,2)*V0+L(1,3)*V0^2
8820 G2=L(2,1)+L(2,2)*V0+L(2,3)*V0^2
8830 G4=L(3,1)+L(3,2)*V0+L(3,3)*V0^2
8840 D8=D8+273.16
8850 G1=L(1,4)+L(1,5)*D8+L(1,6)*D8^2
8860 G3=L(2,4)+L(2,5)*D8+L(2,6)*D8^2
8870 G5=L(3,4)+L(3,5)*D8+L(3,6)*D8^2
8880 D8=D8-273.16
8890 V1=V0*(P(2,N)-INT(P(2,N)))*K0
8900 P5=G0*G1+G2*G3*V1+G4*G5*V1^2
8910 RETURN
9000 REM:LAG-COMP HUM. INPUTS- HUM C7, TEMP C6, HUM RATE C5; OUTPUT G6
9001 REM:J1=HUM LAG-COMP SETTING (0-1: NONE-FULL)
9005 IF C5<0 THEN 9020
9010 G6=0.17*(273.16/(C6+273.16))+0.36*(273.16/(C6+273.16))^17
9015 GO TO 9025
9020 G6=0.2*(273.16/(C6+273.16))+0.75*(273.16/(C6+273.16))^19.3
9025 G6=C7+G6*C5*J1

```

Figure E-3. Listing for Third File of CAPS Dropsonde Program, 8 June 1978 (Page 7 of 8)



```
9030 REM:END OF HYGRISTOR LAG-COMPENSATION PROG
9035 RETURN
9100 STOP
9110 PRINT 'SAFE PROG CASS IN CONSOL . WEN RDY FOR FILE 4, ENTR R - ';
9120 INPUT S$
9130 IF S$='R' THEN 9145
9140 GO TO 9110
9145 DELETE L
9150 FIND 4
9160 DELETE 4750,6960
9170 DELETE 8000,9145
9180 APPEND 9200
9190 REM: MODIFIED FOR CONTINUOUS PRESSURE SENSOR. PK-780216
9192 REM: MODIFICATION- CALC OF THERM AND HUML RES RATIOS
9200 REM:FILE 4 GETS APPENDED HERE
```

Figure E-3. Listing for Third File of CAPS Dropsonde  
Program, 8 June 1978 (Page 8 of 8)



```

9200 REM:FILE4. TO BE APPENDED TO FILE 3 AT LINE 9200
9210 DELETE 9150,9180
9230 REM:EXTRAPOLATE PRES TO SURF. U9=SURF TAG, U6=LAST PRES,
9240 REM:U5=2ND LAST PRES, U7=TAG LAST-TAG 2ND LAST,
9250 REM:U8=SURF TAG-LAST SURF TAG, S9=SURF PRES
9260 F9=INT(P(1,P(2,400))+1)
9270 U9=(INT(P(1,P(1,400))) MAX INT(P(1,P(3,400))))+4 MAX F9+2
9280 U6=P(2,P(2,400))-INT(P(2,P(2,400)))
9290 U5=P(2,P(2,400)-1)-INT(P(2,P(2,400)-1))
9300 U7=INT(P(1,P(2,400)))-INT(P(1,P(2,400)-1))
9310 U8=U9-F9
9320 S9=U6+U8*(U6-U5)/U7
9325 PRINT 'OPR-ENTERED SURF PRES ESTIMATE = ';P2;' MB'
9330 PRINT 'TAGGED-PRES EXTRAPOLATION TO SURF = ';S9
9340 PRINT 'WANT TO CHANGE XTRAPLTD PRES? ENTR 1(+) OR 2(-) - ';
9350 INPUT Z9
9360 GO TO Z9 OF 9380,9400
9370 GO TO 9340
9380 PRINT 'ENTR DESIRED MB PRES FOR SURF (PPPP,P) -- ';
9382 INPUT S9
9384 REM:EXTRAPOLATE & BUILD TAG.P FOR SURF
9386 Z9=U6
9387 Z8=U5
9388 Z9=(S9/10000-Z8)/(Z9-Z8)
9390 Z9=INT(P(1,P(2,400)))+Z9*U7
9392 S9=INT(Z9+0.5)+S9/10000
9400 PRINT 'P(2,400)= ';P(2,400)
9402 PRINT 'WILL STORE ENTRY AS FOLLOWS: P(2, ';P(2,400)+1;')= ';S9
9404 PRINT 'WANT TO RE-ENTR BEFORE STORAGE? ENTR 1(+) OR 2(-)';
9410 INPUT Z9
9420 GO TO Z9 OF 9440,9445
9430 GO TO 9400
9440 GO TO 9380
9445 P(2,400)=P(2,400)+1
9450 P(2,P(2,400))=S9
9455 REM:ASSIGN TEMP & HUM AT SURF
9460 PRINT 'LAST TAG.TEMP & TAG.HUM= ';P(1,P(1,400));' & ';P(3,P(3,400))
9470 PRINT 'OK TO EXTEND THESE VALUES TO SURF? 1(+) OR 2(-) -- ';
9480 INPUT Z9
9490 GO TO Z9 OF 9540,9510
9500 GO TO 9460
9510 PRINT 'ENTR SURF TAG.T & TAG.H (TTTT,TTT,TTTT,HHHH)- ';
9520 INPUT P(1,P(1,400)+1),P(3,P(3,400)+1)
9525 P(1,400)=P(1,400)+1
9530 P(3,400)=P(3,400)+1
9535 GO TO 9590
9540 REM:EXTEND LAST T & H TO SURF (IF OPR-SELECTED)
9541 FOR N=1 TO 3 STEP 2
9545 P(N,P(N,400)+1)=P(N,P(N,400))-INT(P(N,P(N,400)))
9550 P(N,P(N,400)+1)=P(N,P(N,400)+1)+INT(P(2,P(2,400))-2+N)
9560 P(N,400)=P(N,400)+1

```

Figure E-4. Listing for Fourth File of CAPS Dropsonde Program, 8 June 1978 (Page 1 of 11)



```

9570 NEXT N
9580 DELETE 9200,9570
9590 REM:CALC ALTITUDE,REFRACTIVITY PROFILE INT(P(2,N))
9600 REM:MAKE SURE INT(P(2,N)) ARE ALL 0
9615 FOR N=1 TO 399
9620 P(2,N)=P(2,N)-INT(P(2,N))
9625 NEXT N
9650 REM:FETCH SURFACE PRES
9660 V9=10000*(P(2,P(2,400))-INT(P(2,P(2,400))))
9670 REM:CALC LAYER THICKNESSES, INT(P(2,N)) CENTIFEET. V9=BOTTOM PRES,
9680 REM:V8=TOP PR, V7=AUG RH, V6=AUG TEMP, V5=SAT VAP PR, V4=THKNS (M)
9690 FOR N=P(2,400) TO 1 STEP -1
9700 REM:FETCH TOP PRES
9710 V8=P(2,400)
9720 V8=V8-1
9730 IF INT(P(1,V8)+1)<INT(P(1,N)+1) AND V8>1 THEN 9770
9740 IF V8>1 THEN 9720
9742 IF V8<>1 THEN 9750
9744 PRINT 'REACHED END OF PRES FILE WITH ';N;' LAYER(S) NOT CALCULATED'
9746 GO TO 9940
9750 LIST 9740
9760 STOP
9770 Z9=INT(P(1,V8+1))-INT(P(1,V8))
9775 V8=10000*(P(2,V8)-INT(P(2,V8)))
9780 I7=(V9-V8)/Z9
9785 V9=V9+I7
9790 V8=V8+I7
9792 IF V8<V9 THEN 9800
9793 GO TO 9800
9794 LIST 9792
9796 PRINT 'TOP PR=';V8,'BOTTOM PR=';V9
9798 STOP
9800 REM:CALC AVG RH
9810 V7=500*(P(3,N-1)-INT(P(3,N-1))+P(3,N)-INT(P(3,N)))
9820 REM:FETCH AVG TEMP V6
9830 D9=(INT(P(3,N-1))+INT(P(3,N)))/2
9840 GOSUB 7000
9850 V6=D8
9860 REM:CALC SAT VAP PRES V5 USING V6
9870 GOSUB 15000
9880 REM:CALC THICKNESS V4 & INCREMENT ALTITUDE INT(P(2,N))
9890 V4=28.8*(V6+273.16)*(V9*V8)^0.5
9900 V4=V4/(0.18*V7*V5+28.8*((V9*V8)^0.5-0.01*V7*V5))
9910 V4=-29.263242*V4*(LOG(V8/1000)-LOG(V9/1000))
9920 P(2,N-1)=INT(P(2,N))+INT(100*V4/0.3048+0.5)+P(2,N-1)-INT(P(2,N-1))
9925 V9=V8-I7
9930 NEXT N
9940 PRINT 'WANT CENTIFT ALTS CORRESPND'G TO HUM VALUES? 1(+), 2(-) - *;
9950 INPUT Z9
9960 GO TO Z9 OF 9980,10000
9970 GO TO 9940
9980 PRINT @41:'FOLLOWING ARE LISTS OF TAG,TEMP, ALT,PRES, TAG,HUM:'

```

Figure E-4. Listing for Fourth File of CAPS Dropsonde Program, 8 June 1978 (Page 2 of 11)



```

9990 PRINT @41:P
10000 REM:CALC REFRACTIVITIES & STORE IN INT(P(3,N))
10002 FOR N=1 TO 399
10004 F(3,N)=F(3,N)-INT(F(3,N))
10006 NEXT N
10010 FOR N=1 TO F(3,400)
10040 REM:FETCH TEMP D8 AT TAG D9
10050 D8=(P(1,N)-0.1-INT(P(1,N)))*1000
10060 V6=D8
10070 REM:CALC SAT VAP PRES V5 FOR TEMP V6
10080 GOSUB 15000
10090 REM:FETCH PRES V8 MB FOR TAG D9
10105 IF P(2,N)=0 AND N<>P(3,400) THEN 10160
10110 V8=(P(2,N)-INT(P(2,N)))*10000
10115 IF V8=9999 THEN 10160
10120 REM:CALC REFR'Y N-UNITS, V4
10125 Z9=1000*(P(3,N)-INT(P(3,N)))
10130 V4=(77.6*V8-0.056*Z9*V5)/(D8+273.16)
10140 V4=V4+3750*Z9*V5/(D8+273.16)^2
10150 F(3,N)=F(3,N)+INT(V4*1000+0.5)
10160 NEXT N
10170 PRINT "WANT LIST OF ALT AND N UNITS? 1(+) OR 2(-) -- ";
10180 INPUT Z9
10190 GO TO Z9 OF 10210,10230
10200 GO TO 10170
10210 PRINT @41:"FOLLOWING ARE LISTS OF TAG,T, ALT,P, N,H:"
10220 PRINT @41:P
10230 GO TO 21000
15000 REM:CALC SAT VAP PR V5 MB FOR TEMP V6 DEG C; Z9=(1-t)/t
15010 Z9=(1-(V6+273.16)/373.16)/((V6+273.16)/373.16)
15020 V5=1013.246*10^(0.0081238*(10^(-3.49149*Z9)-1))
15030 Z8=(V6+273.16)/373.16
15040 V5=V5/(Z8^5.02808*10^(7.90298*Z9))
15050 V5=V5/10^(1.3816E-7*(10^(11.344*(1-Z8))-1))
15060 RETURN
20000 REM:FETCH PRES V8 MB FOR TAG D9
20005 D9=D9+1
20010 IF D9=>INT(P(1,1))+1 AND D9<=INT(P(1,P(2,400)))+1 THEN 20060
20020 LIST 20010
20030 PRINT "TAG=";D9;" & IS OUTSIDE TAG RANGE FOR PRES FILE"
20035 PRINT "NON-VALID CODE **9999** APPLIED TO PRES V8 (AT N=";N;")"
20040 V8=9999
20045 GO TO 20170
20060 Z9=1
20070 Z9=Z9+1
20080 IF INT(P(1,Z9)+1)=>D9 THEN 20140
20090 GO TO 20070
20140 V8=(D9-INT(P(1,Z9-1)+1))/(INT(P(1,Z9)+1)-INT(P(1,Z9-1)+1))
20150 V8=V8*(P(2,Z9)-INT(P(2,Z9))-(P(2,Z9-1)-INT(P(2,Z9-1))))
20160 V8=10000*(P(2,Z9-1)-INT(P(2,Z9-1))+V8)
20165 D9=D9-1

```

Figure E-4. Listing for Fourth File of CAPS Dropsonde Program, 8 June 1978 (Page 3 of 11)



```

20170 RETURN
21002 PRINT @41:
21004 PRINT @41:
21006 PRINT @41: " ", "DETAILED LIST OF ATMOSPHERIC PARAMETERS"
21008 PRINT @41:
21010 PRINT @41: "ALT(FT)  ALT(M)  PR(MB)  T(DEG-C)  RH(%)  N-UNITS ";
21020 PRINT @41: " M-UNITS  G/M3  D-PT-DEF  N/M  N/M-CLASS"
21030 Z$=" -----"
21040 PRINT @41: Z$; Z$; " -----"
21050 REM: W9=NTH VALUE OF ALT(FT), W8=NTH VALUE OF REFR'Y
21060 FOR N=1 TO P(3,400)
21070 W9=0.01*INT(P(2,N))
21072 IF W9=0 AND N<P(3,400) THEN 21400
21080 W8=INT(P(3,N))/1000
21110 REM: FETCH PR V8 MB FOR TAG D9
21130 V8=(P(2,N)-INT(P(2,N)))*10000
21132 IF V8=9999 THEN 21400
21140 REM: FETCH TEMP D8 DEG C FOR TAG D9
21150 D8=(P(1,N)-0.1-INT(P(1,N)))*1000
21170 W1=1000*(P(3,N)-INT(P(3,N)))
21180 GOSUB 21420
21190 IMAGE6D.X,6D.X,5D.DX,4D.2DX,5D.DX,5D.DX,6D.X,4D.2DX,5D.DX
21200 PRINT @41: USING 21190: W9; 0.3048*W9; V8; D8; W1; W8; W8+0.048*W9, W2, W3
21210 IF N=P(3,400) THEN 21400
21220 W7=0.01*INT(P(2,N+1))
21230 W6=INT(P(3,N+1))/1000
21240 REM: CALC N/M GRAD W5
21250 W5=(W8-W6)/(W9-W7)/0.3048
21280 IF W5<-0.07874 THEN 21340
21290 IF W5<0 THEN 21320
21300 W$=" SUBFR+ "
21310 GO TO 21390
21320 W$=" NORML- "
21330 GO TO 21390
21340 IF W5<-0.1575 THEN 21380
21360 W$=" SPRF-- "
21370 GO TO 21390
21380 W$=" TRP--- "
21390 PRINT @41: USING "74D.4DX,8A": W5; W$
21400 NEXT N
21410 GO TO 21580
21420 REM: CALC ABS HUM W2 GRAMS/CUBIC-M AND DEW POINT DEF W3 DEG C
21430 V6=D8
21440 GOSUB 15000
21450 W2=596*10*(P(3,N)-INT(P(3,N)))*V5/1013.25*373.16/(D8+273.16)
21455 REM: ENTR SBRT HERE IF W2 IS KNOWN & ONLY W3 IS WANTED
21470 V6=D8
21480 GOSUB 15000
21490 W4=0.01*(1000*(P(3,N)-INT(P(3,N))))*V5
21500 V4=V5
21510 V6=D8-1

```

Figure E-4. Listing for Fourth File of CAPS Dropsonde Program, 8 June 1978 (Page 4 of 11)



```

21520 GOSUB 15000
21530 IF ABS(V5-W4)<1.0E-3*W4 THEN 21560
21540 V6=D8-(D8-V6)*(V4-W4)/(V4-V5)
21550 GO TO 21520
21560 W3=D8-V6
21570 RETURN
21580 LIST 21600
21585 PRINT 'IF WANT COPY DISPLAY, DO SO BEFOR CONTINUING RUN'
21590 STOP
21600 REM:END OF PRINTOUT; WILL GO TO PLOT.
30000 REM:PLOT ALTITUDE PROFILES OF TEMP & HUM
30005 PAGE
30010 REM:SELECT ALT SCALE
30011 N=1
30012 U0=0
30014 U0=U0 MAX INT(P(1,N))+1
30015 IF U0>INT(P(1,N))+1 THEN 30020
30017 N=N+1
30018 GO TO 30014
30020 IF 0.01*U0>15000 THEN 30050
30030 U0=15000
30040 GO TO 30095
30050 U0=30000
30095 REM:PLOT TEMP AXES
30100 VIEWPORT 5,75,5,95
30110 WINDOW -40,30,-500,U0
30120 AXIS 5,U0/15,-40,0
30130 MOVE -40,U0
30140 PRINT 'KBHKT', 'TEMP(DEG C)', ' ', 'RH(%)'
30150 PRINT U0/1000, ' ', 'HHDROP #';NO;'JBBBBBBBB';D1
30160 MOVE -40,2*U0/3
30170 PRINT 'HH';2*U0/3000
30180 MOVE -40,U0/3
30190 PRINT 'HH';U0/3000
30200 MOVE -40,0
30210 PRINT 'H0'
30220 MOVE 0,-500
30230 PRINT 'JOK'
30240 MOVE -20,-500
30250 PRINT 'JHH-20K'
30260 MOVE 20,-500
30270 PRINT 'JB20K'
30280 REM:PLOT TEMPS
30290 D7=1
30300 FOR N=2 TO P(3,400)
30320 D8=(P(1,N-1)-0.1-INT(P(1,N-1)))*1000
30325 D0=0.01*INT(P(2,N-1))
30330 IF ABS(D8)>60 OR D0=0 THEN 30390
30340 MOVE D8,D0
30360 I8=(P(1,N)-0.1-INT(P(1,N)))*1000
30365 D0=0.01*INT(P(2,N))

```

Figure E-4. Listing for Fourth File of CAPS Dropsonde Program, 8 June 1978 (Page 5 of 11)



```

30370 IF ABS(D8)>60 OR D0=0 THEN 30390
30380 DRAW D8,D0
30390 NEXT N
30395 REM:PLOT HUM AXES
30400 VIEWPORT 77,127,5,95
30410 WINDOW 0,100,-500,U0
30420 AXIS 10,U0/15
30430 MOVE 0,-500
30440 PRINT 'J0K'
30450 MOVE 50,-500
30460 PRINT 'JH50K'
30470 MOVE 100,-500
30480 PRINT 'JHH100K'
30490 REM:PLOT HUMS
30500 FOR N=2 TO P(3,400)
30510 D9=1000*(P(3,N-1)-INT(P(3,N-1)))
30515 D0=0.01*INT(P(2,N-1))
30520 IF D9>100 OR D0=0 THEN 30570
30530 MOVE D9,D0
30540 D9=1000*(P(3,N)-INT(P(3,N)))
30545 D0=0.01*INT(P(2,N))
30550 IF D9>100 OR D0=0 THEN 30570
30560 DRAW D9,D0
30570 NEXT N
30574 COPY
30576 FOR N=1 TO 2200
30578 NEXT N
30580 COPY
30582 FOR N=1 TO 2200
30583 NEXT N
30584 COPY
30586 PAGE
40000 REM:PLOT ALTITUDE PROFILES OF N- & M-UNITS
40050 VIEWPORT 5,75,5,95
40060 WINDOW 200,400,-500,U0
40070 AXIS 20,U0/15,200,0
40080 MOVE 200,U0
40090 PRINT 'KBBKFT','REFR'Y(N-UNITS)',',',',M-UNITS'
40100 PRINT U0/1000,',',',BBIDROP #';NO;'JBBBBBBBB';01
40110 MOVE 200,2*U0/3
40120 PRINT 'HH';2*U0/3000
40130 MOVE 200,U0/3
40140 PRINT 'HH';U0/3000
40150 MOVE 200,0
40160 PRINT 'H0'
40170 MOVE 300,-500
40180 PRINT 'JH300K'
40190 MOVE 240,-500
40200 PRINT 'JH240K'
40210 MOVE 360,-500
40220 PRINT 'JH360K'

```

Figure E-4. Listing for Fourth File of CAPS Dropsonde Program, 8 June 1978 (Page 6 of 11)



```

40230 REM:PLOT N-UNITS
40240 D7=1
40250 FOR N=2 TO P(3,400)
40260 D8=INT(P(3,N-1))/1000
40270 D0=0.01*INT(P(2,N-1))
40280 IF ABS(D8-600)>400 OR D0=0 THEN 40340
40290 MOVE D8,D0
40300 D8=INT(P(3,N))/1000
40310 D0=0.01*INT(P(2,N))
40320 IF ABS(D8-600)>400 OR D0=0 THEN 40340
40330 DRAW D8,D0
40340 NEXT N
40350 VIEWPORT 77,127,5,95
40360 WINDOW 300,900,-500,U0
40370 AXIS 100,U0/15,300,0
40380 MOVE 300,-500
40390 PRINT 'JH300K'
40400 MOVE 600,-500
40410 PRINT 'JH600K'
40420 MOVE 900,-500
40430 PRINT 'JHH900K'
40440 REM:PLOT M-UNITS
40450 FOR N=2 TO P(2,400)
40460 D9=INT(P(3,N-1))/1000
40465 D9=D9+0.048*0.01*INT(P(2,N-1))
40467 D0=0.01*INT(P(2,N-1))
40470 IF ABS(D9-600)>390 OR D0=0 THEN 40520
40480 MOVE D9,D0
40490 D9=INT(P(3,N))/1000
40495 D9=D9+0.048*0.01*INT(P(2,N))
40497 D0=0.01*INT(P(2,N))
40500 IF ABS(D9-600)>390 OR D0=0 THEN 40520
40510 DRAW D9,D0
40520 NEXT N
40522 COPY
40524 FOR N=1 TO 2200
40526 NEXT N
40528 COPY
40530 FOR N=1 TO 2200
40532 NEXT N
40534 COPY
40536 PAGE
45000 REM:LIST SIGNIF LEVELS (BASED ON LINEAR FIT OF T&H TO ALT)
45002 PRINT @41:
45003 PRINT @41:
45005 FRI @41:' ', 'SIGNIF LEVS (T1,H10) LIST OF ATMOSPHERIC PARAMETERS'
45007 PRINT @41:
45010 DELETE S
45020 DIM S(2,9),O(9)
45030 RESTORE 45050
45040 READ @34:S9,S8,S,O,M

```

Figure E-4. Listing for Fourth File of CAPS Dropsonde Program, 8 June 1978 (Page 7 of 11)



```

45050 DATA 2,0,1.0E-3,0,-9.0E+99,9.0E+99,0,0,0,0,0,0,0.01,0,-9.0E+99
45055 DATA 9.0E+99,0,0,0,0,0,9.0E+99,0,0,0,0,0,0,0,0,1
45060 REM:LIST FT,M,MB,DEG-C,%RH,N,M-UNITS,G/M3,D-PT-DEF
45070 PRINT @41:"ALT(FT) ALT(M) PR(MB) T(DEG-C) RH(%) N-UNITS ";
45080 PRINT @41:" M-UNITS G/M3 D-PT-DEF"
45090 Z$=" ----- "
45100 PRINT @41:Z$;Z$;" -----"
45110 REM:W9=NTH VALUE OF ALT(FT), W8=NTH VALUE OF REFR'Y
45120 FOR N=P(2,400) TO 2 STEP -1
45130 W9=0.01*INT(P(2,N))
45150 W8=INT(P(3,N))/1000
45160 REM:FETCH PR V8 MB FOR TAG D9
45180 V8=(P(2,N)-INT(P(2,N)))*10000
45190 IF V8=9999 THEN 45500
45200 REM:FETCH TEMP D8 DEG C FOR TAG D9
45210 D8=(P(1,N)-0.1-INT(P(1,N)))*1000
45220 W1=1000*(P(3,N)-INT(P(3,N)))
45222 REM:CALC ABS HUM W2 & DEW-PT-DEF W3
45224 GOSUB 21420
45230 P9=1.1+D8/1000
45240 N9=100*W9+1.0E-3
45250 IF N9=1.0E-3 AND INT(S(M,9))=0 AND INT(S(M,2))>0 THEN 45500
45260 GOSUB 45520
45270 P9=2+W1/1000
45280 GOSUB 45520
45285 IF N=1 THEN 45300
45290 IF S8<>1 THEN 45340
45300 S8=0
45320 IMAGE6D.X,6D.X,5D.DX,4D.2DX,5D.DX,5D.DX,6D.X,4D.2DX,5D.DX
45330 PRINT @41: USING 45320:0
45340 O(1)=W9
45350 O(2)=0.3048*W9
45360 O(3)=V8
45370 O(4)=D8
45380 O(5)=W1
45390 O(6)=W8
45400 O(7)=W8+0.048*W9
45410 O(8)=W2
45420 O(9)=W3
45500 NEXT N
45510 GO TO 49000
45520 REM:FIND SIGNIFICANT VALUES
45530 REM:INPUT IS ID-TAGGED VALUE P9 & LINEARITY BASE N9
45540 REM:INPUT TOLERANCES ARE S(M,1)
45550 REM:OUTPUTS:BASE-TAGGED VALUES S(M,2) WITH FLAG S8=1 WEN SIGNIF
45560 M=INT(P9)
45570 REM:CALCULATE NEW SLOPE S(M,5)
45580 S(M,5)=(P9-INT(P9)-(S(M,2)-INT(S(M,2))))/(N9-INT(S(M,2)))
45660 REM:TEST NEW SLOPE
45665 IF N<=2 THEN 45690
45670 IF S(M,5)>S(M,3) AND S(M,5)<=S(M,4) THEN 45692

```

Figure E-4. Listing for Fourth File of CAPS Dropsonde Program, 8 June 1978 (Page 8 of 11)



```

45680 REM:NEW SLOPE NOT OK; SET FLAG
45690 S8=1
45692 REM:UPDATE LAST LEVEL
45694 S(M,8)=S(M,9)
45696 S(M,9)=INT(N9)+(P9-INT(P9))
45700 IF M<S9 THEN 45930
45720 REM:FOR ALL M, DECLARE LAST VALUE IF SIGNIF, SET NEW LIMITS
45730 FOR M=1 TO S9
45735 IF S8<>1 THEN 45762
45740 S(M,2)=S(M,8)
45750 S(M,3)=-9.0E+99
45760 S(M,4)=9.0E+99
45762 REM:CALCULATE NEW ACCEPTANCE SLOPE LIMITS
45764 IF N9>INT(S(M,2)) THEN 45772
45766 S(M,6)=S(M,9)-INT(S(M,9))+S(M,1)-(S(M,2)-INT(S(M,2)))
45767 S(M,6)=S(M,6)/(N9-INT(S(M,2)))
45768 S(M,7)=S(M,9)-INT(S(M,9))-S(M,1)-(S(M,2)-INT(S(M,2)))
45769 S(M,7)=S(M,7)/(N9-INT(S(M,2)))
45770 GO TO 45780
45772 S(M,6)=S(M,9)-INT(S(M,9))-S(M,1)-(S(M,2)-INT(S(M,2)))
45773 S(M,6)=S(M,6)/(N9-INT(S(M,2)))
45774 S(M,7)=S(M,9)-INT(S(M,9))+S(M,1)-(S(M,2)-INT(S(M,2)))
45775 S(M,7)=S(M,7)/(N9-INT(S(M,2)))
45780 REM:UPDATE SLOPE ACCEPTANCE LIMITS. START WITH TEST OF MIN SLOPE
45790 IF S(M,6)>S(M,3) THEN 45820
45800 REM:MIN ACCEPTABLE SLOPE OK AS IS
45810 GO TO 45840
45820 REM:UPDATE MIN ACCEPTABLE SLOPE
45830 S(M,3)=S(M,6)
45840 REM:NOW TEST MAX SLOPE
45850 IF S(M,7)<S(M,4) THEN 45880
45860 REM:MAX ACCEPTABLE SLOPE O.K. AS IS
45870 GO TO 45900
45880 REM:UPDATE MAX ACCEPTABLE SLOPE
45890 S(M,4)=S(M,7)
45900 NEXT M
45901 M=M-1
45930 RETURN
49000 REM:LIST ATMOSPHERIC PARAMETERS AT MANDATORY PRES LEVELS Y(M)
49001 PRINT @41:
49002 PRINT @41:
49003 PRINT @41:" ", "MANDATORY LEVELS"
49004 PRINT @41:
49005 PRINT @41:"ALT(FT)  ALT(M)  PR(MB)  T(DEG-C)  RH(%)  N-UNITS ";
49006 PRINT @41:" M-UNITS  G/M3  D-PT-DEF"
49007 Z$=" ----- "
49008 PRINT @41:Z$;Z$;" -----"
49010 DIM Y(7)
49020 RESTORE 49040
49030 READ @34:Y,M,T9
49040 DATA 1000,850,700,500,400,300,250,0,1

```

Figure E-4. Listing for Fourth File of CAPS Dropsonde Program, 8 June 1978 (Page 9 of 11)



```

49050 REM:FETCH SURF PRES FROM P ARRAY
49060 V8=10000*(P(2,P(2,400))-INT(P(2,P(2,400))))
49070 REM:FETCH TIME-TAG D9 FROM P ARRAY USING PR V8
49080 GOSUB 49370
49090 REM:USE TAG D9 IN (P(1,N)+2) TO FIND N & INTERP FRACTION NO
49095 IF D9=1 THEN 49355
49100 GOSUB 49510
49110 REM:USE N & NO TO GET ALT W9 FROM P(2,N)
49120 W9=INT(P(2,N))
49122 IF M>0 THEN 49130
49124 W9=INT(P(2,P(2,400)))/100
49126 GO TO 49150
49130 Z9=INT(P(2,N-1))
49140 W9=0.01*(W9+NO*(Z9-W9))
49145 IF T9=>W9 THEN 49355
49150 REM:USE N & NO TO GET N-UNITS W8 FROM INT(P(3,N))
49160 W8=INT(P(3,N))/1000000
49170 Z9=INT(P(3,N-1))/1000000
49180 W8=1000*(W8+NO*(Z9-W8))
49190 REM:FETCH TEMP D8 FOR TAG D9
49195 D9=D9-2
49200 GOSUB 7000
49205 D9=D9+2
49210 REM:USE N & NO TO GET %RH, W1
49220 W1=P(3,N)-INT(P(3,N))
49230 Z9=P(3,N-1)-INT(P(3,N-1))
49240 W1=1000*(W1+NO*(Z9-W1))
49250 REM:CALC ABS HUM W2
49252 V6=D8
49254 GOSUB 15000
49256 W2=596*0.01*W1*V6/1013.25*373.16/(D8+273.16)
49258 REM:CALC DEW-PT-DEP W3
49260 GOSUB 21455
49270 PRINT @41: USING 45320:W9,0.3048*W9,V8,D8,W1,W8,W8+0.048*W9,W2,W3
49275 T9=W9
49280 IF M>0 THEN 49320
49290 REM:SURF PR DONE. OMIT 1000 MB IF SURF PR <=1000
49300 IF V8>1000 THEN 49320
49310 M=M+1
49320 M=M+1
49330 IF M=8 THEN 49355
49340 V8=Y(M)
49350 GO TO 49070
49355 PRINT *END OF PROCESSING*
49357 REM: THIS FILE ALTERED FOR CONT PRES SENSOR; PK-MCW-780314
49360 END
49370 REM:FETCH TAG D9 FOR PR V8
49380 D9=P(2,400)
49390 Z8=10000*(P(2,D9)-INT(P(2,D9)))
49400 Z9=10000*(P(2,D9-1)-INT(P(2,D9-1)))
49410 IF V8<Z9 THEN 49480

```

Figure E-4. Listing for Fourth File of CAPS Dropsonde Program, 8 June 1978 (Page 10 of 11)



```

49420 IF V8<=Z8 THEN 49460
49430 LIST 49420
49440 PRINT 'PR V8 TOO GREAT FOR TABLE F(2, )'
49450 STOP
49460 F9=(Z9-Z8)*(INT(P(1,D9-1)+1)-INT(P(1,D9)+1))+0.5
49465 D9=INT(P(1,D9)+1)+INT((V8-Z8)/F9)
49470 GO TO 49500
49480 D9=D9-1
49485 IF D9=1 THEN 49500
49490 GO TO 49390
49500 RETURN
49510 REM:USE TAG D9 TO FIND INTERP BASE N & FRACTION NO FROM F(3, )
49520 N=P(3,400)
49530 Z8=INT(P(1,N))+2
49540 Z9=INT(P(1,N-1))+2
49550 IF D9<Z9 THEN 49620
49560 IF D9<=Z8 THEN 49600
49570 LIST 49560
49580 PRINT 'TAG D9 > TABLE TAGS'
49590 STOP
49600 N0=(D9-Z8)/(Z9-Z8)
49610 GO TO 49640
49620 N=N-1
49630 GO TO 49530
49640 RETURN

```

Figure E-4. Listing for Fourth File of CAPS Dropsonde  
Program, 8 June 1978 (Page 11 of 11)



APPENDIX F  
PROGRAM LISTING FOR MINIREFRACTIONSONDE ANALYSIS



APPENDIX F. PROGRAM LISTING FOR MINIREFRACTIONSONDE ANALYSIS

The four program files of cassette X, Minirefractiosonde Analysis, are listed in the four figures of this appendix as tabulated below.

<u>Cassette Number</u>	<u>File on Cassette</u>	<u>Program Name</u>	<u>Figure Number</u>
X	1	CALIBRATION AND ACQUISITION	F-1
X	2	REDUCED DATA FILE BUILDER	F-2
X	3	TEMP, PRES, HUM TABLE BUILDER	F-3
X	4	OUTPUT REPORT GENERATOR	F-4



```

100 GO TO 1000
110 DELETE 1000,3110
120 PRINT 'SET HP AS ADDR 3 FOR INPUT. ENTER MINUTES OF DATA ( <34.5 )'
130 INIT
140 Y=0
160 INPUT M
170 M=INT(105*M+33)
180 DIM Z$(2),T(M),U$(17),T$(14)
185 T=0
190 PRINT @3,32:'PF7G1S17;R'
200 ON SRQ THEN 220
210 WAIT
220 FOR N=1 TO M
230 INPUT @3:U$
240 T$=SEG(U$,6,7)
244 INPUT @3:U$
246 INPUT @3:U$
250 INPUT @3:U$
260 U$=SEG(U$,7,6)
270 T$=U$&T$
280 T(N)=VAL(T$)
284 INPUT @3:U$
286 INPUT @3:U$
290 NEXT N
300 OFF SRQ
310 PRINT 'PRS CR WEN RDY TO CK INPUT'
320 INPUT Z$
330 PRINT T
360 PRINT 'ENTER 1(REDISPLAY) OR 2(CONTINUE) OR 3(ABORT)'
370 INPUT Z$
380 GO TO VAL(Z$) OF 310,410,390
390 PRINT 'RUN ABORTED'
400 END
410 PRINT 'PREPARE TO STORE DATA ON INTERNAL TAPE. ENTER FILE NO.'
420 INPUT Y
430 PRINT 'WILL STORE IN FILE ';Y;'. ENTER + WEN RDY'
440 INPUT Z$
450 IF Z$='+' THEN 490
460 LIST 410
470 PRINT 'RUN ABORTED'
480 STOP
490 FIND Y
500 MARK 1,10*(M+1)
510 FIND Y
515 WRITE M
520 FOR N=M TO 1 STEP -1
530 WRITE T(N)
540 NEXT N
550 PRINT 'FILE WRITTEN'
560 END
1000 PAGE

```

Figure F-1. Listing for First File of Mini Refraction  
Sonde Program, 8 June 1978 (Page 1 of 3)



```

1005 PRINT '          REFRACTION BALLOONSONDE DATA ANALYZER -- NADC AVTD'
1010 PRINT
1020 PRINT 'ENTER PROG SELECTION 1 OR 2: 1-CAL&ACQ 2-ANALYSIS -- ';
1030 INPUT Z
1040 GO TO Z OF 2000,3000
2000 INIT
2010 PRINT '  ', 'CALIBRATION AND DATA ACQUISITION'
2020 PRINT
2030 PRINT
2050 PRINT 'ENTER LAUNCH DATE AND NUMBER (YYMMDD NN) -- ';
2060 INPUT D,N$
2070 PRINT 'ENTER ZULU LAUNCH TIME (HHMMSS) -- ';
2080 INPUT T$
2110 PRINT 'ENTER ALT & PRES AT LAUNCH (M,MB) -- ';
2120 INPUT P1,P2
2130 PRINT 'ENTER SONDE SERIAL NO. (NNNNNN) -- ';
2140 INPUT S$
2144 PRINT 'ENTER REFERENCE VOLTAGE RATIO -- ';
2146 INPUT KO
2150 PRINT 'THERM LOCKIN: ENTER KOHMS AND DEG C (RR.RRR ,TT.T) -- ';
2160 INPUT R3,T3
2170 PRINT 'ENTER HUML LOCKIN RES IN KOHMS (RR.RRR) -- ';
2180 INPUT R4
2181 DIM L(3,6)
2182 PRINT 'ENT PRES COEF L(1,1-6) ';
2183 INPUT L(1,1),L(1,2),L(1,3),L(1,4),L(1,5),L(1,6)
2185 PRINT 'ENT PRES COEF L(2,1-6) ';
2186 INPUT L(2,1),L(2,2),L(2,3),L(2,4),L(2,5),L(2,6)
2188 PRINT 'ENT PRES COEF L(3,1-6) ';
2189 INPUT L(3,1),L(3,2),L(3,3),L(3,4),L(3,5),L(3,6)
2210 PRINT 'ENTER OPERATOR-DATE CODE (ABCYYMMDD) -- ';
2220 INPUT O$
2432 PRINT 'IF WANT COPY OF THIS PAGE, ENTER + (IF NOT, ENTER -) -- ';
2434 INPUT Z$
2436 IF Z$ <> '+' THEN 2440
2438 COPY
2440 PAGE
2450 PRI 'DATE(YYMMDD): ';D;' LAUNCH NO. ';N$;' SONDE SER. NO. ';S$
2470 PRINT
2480 PRI 'THERM LOCK-IN: ';R3;' KOHMS AT ';T3;' DEG C', ' HUML: ';R4;'K'
2490 PRINT
2500 PRINT '  ', 'LAUNCH'
2510 PRINT 'TIME (HHMMSS)',T$
2520 PRINT 'P1 ALT. (M)',P1
2530 PRINT 'P2 PRES. (MB)',P2
2532 PRINT
2534 PRINT 'PRESSURE COEFF OF ARRAY L(3,6) ARE AS FOLLOWS:'
2536 PRINT L
2538 PRINT
2560 PRINT '  ',O$
2570 PRINT 'WANT CHANGE CAL DATA? (ENTR + IF YES, - IF NO):';

```

Figure F-1. Listing for First File of Mini Refraction  
Sonde Program, 8 June 1978 (Page 2 of 3)



```

2575 INPUT Z$
2580 IF Z$<>'-' THEN 2584
2582 GO TO 2630
2584 PRINT 'ENTR CHANGE (EG: P1=NN.N) THEN RUN AFTER STOP'
2586 STOP
2588 GO TO 2440
2630 COPY
2632 PRINT @41:
2634 PRINT @41:
2636 PRI @41:'DATE(YMMDD): ';D;' LAUNCH NO. ';N$;' SONDE SER. NO. ';S$
2637 PRI @41:'THER LOC-IN: ';R3;' KOHMS @ ';T3;' DEG C';' HUML: ';R4;'K'
2638 PRI @41:'LAUNCH ALT = ';P1;'M', 'LAUNCH PRES = ';P2;'MB'
2639 PRINT @41:'PRESSURE COEFF OF ARRAY L(3,6) ARE AS FOLLOWS:'
2640 PRINT @41:L
2645 PAGE
2660 PRI 'PREPARE TO STORE CAL DATA: NOTE CASS NO. & LOAD CASS IN 4051'
2665 PRI '(ASCERTAIN FILE 1 ON CASS HAS BEEN MARKED BEFORE CONTINUING)'
2670 PRINT 'ENTER CASSETTE NO. AND ADDRESS OF CASSETTE UNIT (NN) -- ';
2680 INPUT X
2690 TLIST
2695 PRINT 'ANY FILE # >= SPECIFIED # WILL BE DESTROYED'
2700 PRINT 'ENTER FILE NO. FOR STORING CAL DATA (FF) -- ';
2710 INPUT Z1
2720 FIND Z1
2730 MARK 1,3000
2740 FIND Z1
2750 PRINT @33:D,N$,T$,P1,P2,S$,T3,R3,R4,L,K0,Q$
2755 CLOSE
2760 PRINT 'CAL DATA STORED IN FILE ';Z1;' ON CASSETTE ';X;' ';O$
2761 PRINT 'IF WANT TO WRITE ANOTHER CAL DATA FILE, ENTER + (- IF NOT)'
2762 INPUT Z$
2763 IF Z$='+' THEN 2660
2765 GO TO 110
2990 STOP
3000 REM:DATA ANALYSIS STARTS HERE
3010 DELETE 100,2990
3020 PRINT 'WILL READ DATA ANALYSIS PROG FROM INTERNAL CASSETTE FILE 2'
3030 PRINT ' ENTER R WEN RDY -- ';
3040 INPUT S$
3050 IF S$='R' THEN 3090
3060 LIST 3020
3070 PRINT 'RUN ABORTED'
3080 STOP
3090 FIND 2
3100 APPEND 3110
3105 REM:FILED IN CASS 8, FILE 1. PK-MCW-780216
3107 REM:MODIFIED FOR CONTINUOUS PRESSURE SENSOR. PK-780216
3108 REM:MODIFICATION- ADD OF REFERENCE VOLTAGE RATIO (KO) INPUT
3110 REM:DATA ANALYSIS PROG WILL BE APPENDED HERE

```

Figure F-1. Listing for First File of Mini Refraction  
Sonde Program, 8 June 1978 (Page 3 of 3)





```

3312 NEXT I9
3314 RESTORE 3318
3316 READ @34:F(1,400),F(2,400),F(3,400),S
3318 DATA 0,0,0,0.007,0,-9.9E+99,9.9E+99,0,0,0,0,0.007,0,-9.9E+99
3320 DATA 9.9E+99,0,0,0,0,0.008,0,-9.9E+99,9.9E+99,0,0,0,0
3322 PRINT 'SELECT DATA SOURCE: 1=PACKED FILE, 2=REDUCED FILE -- ';
3324 INPUT S9
3326 GO TO S9 OF 3346,3330
3328 STOP
3330 PRINT 'PUT "SAFE" CASS (FILE 23=P ARRAY) IN 4051. ENT R WN RBY - ';
3332 INPUT S$
3334 IF S$='R' THEN 3338
3336 GO TO 3330
3338 DIM F(3,400)
3340 FIND 23
3342 READ @33:F
3343 PRINT 'CK & CORRECT F(M,N), THEN "RUN(LINE # AFTER STOP)"';
3344 STOP
3345 GO TO 3382
3346 FIND Z8
3348 READ @33:Z7
3350 Z6=0
3352 Z6=Z6+1
3354 READ @33:Z0
3356 GO TO 3360
3358 PRINT @41:Z6,Z0;
3360 REM:UNPACK FIRST HALF Z0 TO GET PERIOD Z1
3362 Z1=INT(Z0)/1.0E+8
3364 REM:PROCESS UNPACKED VALUE
3366 GOSUB 3384
3368 REM:UNPACK & PROCESS SECOND PERIOD
3370 Z1=(Z0-INT(Z0))/100
3372 GOSUB 3384
3374 REM:WAS THIS WORD THE LAST IN FILE?
3375 REM:SEV SEC PRE-LAUNCH DATA MUST BE IN PACK FILE FOR SURF VALUE
3376 IF Z6=Z7 THEN 3378
3377 GO TO 3352
3378 T9=T9+4
3379 A=0
3380 GOSUB 3498
3381 PRINT 'LAST ENTRY HAS BEEN READ FROM PACKED DATA FILE'
3382 GO TO 3975
3383 GO TO 4195
3384 REM:TESTING & MAINTAINING SYNC
3385 REM:T9 SAMPS ENTERED STACK SINCE LAUNCH. T8=LAST REF TAG
3386 IF T9=0 THEN 3512
3388 GO TO T6 OF 3396,3406,3406,3466
3390 LIST 3388
3392 PRINT 'T6=';T6
3394 STOP
3396 REM:CYCLE SHIFT
3398 A0=A(4)
3400 A=B

```

Figure F-2. Listing for Second File of Mini Refraction  
Sonde Program, 8 June 1978 (Page 2 of 8)



```

3402 B=C
3404 T9=T9+4
3406 IF Z1>1/L1 AND Z1<1/L0 THEN 3440
3408 IF Z1=>1/L2 AND Z1<=1/L1 THEN 3416
3410 REM:Z1 NOT DATA AND NOT REF. APPLY NON-VALID TAG (.1)
3412 Z1=0.1+Z1
3414 GO TO 3440
3416 GO TO T6 OF 3420,3426,3432,3418
3418 STOP
3420 C(1)=0.99999
3422 T6=T6+1
3424 T7=T7+1
3426 C(2)=0.99999
3428 T6=T6+1
3430 T7=T7+1
3432 C(3)=0.99999
3434 T6=T6+1
3436 T7=T7+1
3438 GO TO 3384
3440 GO TO T6 OF 3448,3454,3460,3466
3442 LIST 3440
3444 PRINT 'T6=';T6
3446 STOP
3448 C(1)=Z1
3450 T6=2
3452 GO TO 3592
3454 C(2)=Z1
3456 T6=3
3458 GO TO 3592
3460 C(3)=Z1
3462 T6=4
3464 GO TO 3592
3466 IF Z1=>1/L2 AND Z1<=1/L1 THEN 3482
3468 REM:REF EXPECTED BUT MISSING; ADD SYNC-LOSS TAG .99 TO DDR SAMPS
3476 C(4)=Z1
3478 C=0.99+C
3479 GO TO 3484
3482 T8=T9+T7
3483 C(4)=Z1
3484 T6=1
3485 PRINT 'T9,T7,T8=',T9,T7,T8
3486 PRINT 'B=';T9+T7-7+B(1),T9+T7-6+B(2),T9+T7-5+B(3),T9+T7-4+B(4)
3488 REM:RESTORE CYCLE IN ARRAY B, IF NEEDED
3490 GOSUB 3594
3492 REM:CALCULATE PERIOD RATIOS IN ARRAY A
3494 GOSUB 3664
3496 PRINT @41:A(1),A(2),A(3),T9+T7-8+A(4)
3498 REM:SCAN ARRAY A & DETECT SIG RATIOS
3500 FOR N8=1 TO 3
3502 F9=N8+A(N8)
3504 N9=T9+T7-12+N8
3506 GOSUB 3695
3508 NEXT N8

```

Figure F-2. Listing for Second File of Mini Refraction  
Sonde Program, 8 June 1978 (Page 3 of 8)



```

3510 GO TO 3592
3512 REM:LOOKING FOR FIRST SYNCHRONIZED CYCLE
3514 GO TO T6 OF 3516,3522,3522,3522,3532
3516 REM:IS Z1 A REF SIGNAL?
3518 IF Z1=>1/L2 AND Z1<=1/L1 THEN 3536
3520 GO TO 3588
3522 REM:IS Z1 A DATA SIGNAL?
3524 IF Z1>1/L1 AND Z1<=1/L0 THEN 3542
3526 PRINT 'FALSE START. T6=';T6
3528 T6=1
3530 GO TO 3512
3532 IF Z1=>1/L2 AND Z1<=1/L1 THEN 3566
3534 GO TO 3526
3536 T6=2
3538 B(4)=Z1
3540 GO TO 3588
3542 GO TO T6 OF 3544,3548,3554,3560,3544
3544 LIST 3542
3546 STOP
3548 T6=3
3550 C(1)=Z1
3552 GO TO 3588
3554 T6=4
3556 C(2)=Z1
3558 GO TO 3588
3560 T6=5
3562 C(3)=Z1
3564 GO TO 3588
3566 REM:T9 IS NO. OF SAMPS TO 'ENTER' STACK SINCE LAUNCH
3568 T9=T0*10+8
3569 T8=T9
3570 T6=1
3572 C(4)=Z1
3574 PRINT Z6+T7+Z1
3576 PRINT
3578 PRINT 'LAST 5 SAMPS ARE FIRST CYCLE PASSING RODDR RANGE TEST'
3580 PRINT
3582 PRINT 'REF STARTING 1ST SYNC CYCLE (TIME-TAG + PER): ';T9-4+B(4)
3584 PRINT 'FOLLOWING SAMPS ARE OUTPUT FROM SYNC TEST & MAINTENANCE'
3586 GO TO 3592
3588 REM:PRINT FILE ENTRY NO.(Z6) & PERIOD
3590 PRINT Z6+T7+Z1;' '
3592 RETURN
3594 REM:VALIDATE DATA IN ARRAY C USING LIMITS IN D
3596 FOR N9=1 TO 4
3598 GO TO N9 OF 3606,3600,3604,3606
3600 D(2)=400*D(2)
3602 GO TO 3606
3604 D(2)=D(2)/400
3606 IF ABS(A(N9)-C(N9))<D(N9) OR ABS(B(N9)-C(N9))<D(N9) THEN 3610
3608 PRINT 'C(';N9;') FAILS VAL TEST.TIME-TAGGED PER.=';T9+T7-4+N9+C(N9)
3610 NEXT N9
3612 REM:RESTORE DATA IN ARRAY B

```

Figure F-2. Listing for Second File of Mini Refraction  
Sonde Program, 8 June 1978 (Page 4 of 8)



```

3613 N8=0
3614 FOR N9=1 TO 4
3615 IF N9<3 THEN 3619
3616 IF A(N9)/B(N9)<1.02 AND A(N9)/B(N9)>0.980392 THEN 3642
3617 GOSUB 3150
3618 GO TO L9 OF 3642,3628
3619 IF ABS(A(N9)-B(N9))<D(N9) THEN 3642
3620 REM:B(N9)NOT OK. CAN C(N9) BE USED TO RESTORE?
3622 IF ABS(A(N9)-C(N9))<D(N9) THEN 3628
3624 REM:C(N9) NOT OK FOR RESTORATION
3626 GO TO 3642
3628 REM:RESTORE B(N9)
3630 PRINT
3632 PRINT "RESTORED PACK-WORD";Z6-1;" FROM ";T9+T7-8+N9+B(N9);" TO ";
3634 B(N9)=(A(N9)+C(N9))/2
3636 PRINT T9+T7-8+N9+B(N9)
3638 PRINT
3640 GO TO 3646
3642 REM:NO RESTORATION. INCREMENT COUNT OF NON-RESTORED SAMPS (N8)
3644 N8=N8+1
3646 NEXT N9
3648 IF N8<4 THEN 3652
3650 GO TO 3660
3652 PRINT
3654 PRINT "RESTORED CYCLE FOLLOWS:"
3656 PRINT T9+T7-7+B(1),T9+T7-6+B(2),T9+T7-5+B(3),T9+T7-4+B(4)
3658 PRINT
3660 N8=0
3662 RETURN
3664 REM:CALCULATE PERIOD RATIOS IN ARRAY A
3666 IF A(1)=0 AND A(2)=0 AND A(3)=0 THEN 3690
3668 IF A0=>1/L2 AND A0<=1/L1 AND ABS(A0-A(4))<D(4) THEN 3676
3669 C(1)=0.999
3670 C(2)=0.999
3671 C(3)=0.999
3672 PRINT @41:"TAGS ";T9+T7-13;"8";T9+T7-9;" FAIL REF COMP;ADD .999"
3674 GO TO 3690
3676 FOR N9=1 TO 3
3678 IF A(N9)<1/L0 THEN 3686
3680 LIST 3678
3682 PRINT "A(N9)= ";A(N9)
3686 A(N9)=(A0*(4-N9)+A(4)*N9)/(4*A(N9))
3688 NEXT N9
3690 RETURN
3695 REM:THIS SBRT MODIFIED TO MAKE ENTIRE LEVEL SIG IF ANY
3700 REM:ON THAT LEVEL ARE SIG- PK-780310
3705 REM:INPUT IS ID-TAGGED PERIOD RATIO P9 AT TIME N9 (SAMPLE NO.)
3710 REM:INPUT TOLERANCES ARE S(M,1)
3715 REM:OUTPUTS ARE TIME-TAGGED SIGNIFICANT LEVELS P(M,N)
3720 REM:P(M,400) IS NO. OF SIGNIF LEVS STORED
3725 M=INT(P9)
3730 REM:CALCULATE NEW SLOPE S(M,5)
3735 S(M,5)=(P9-INT(P9)-(S(M,2)-INT(S(M,2))))/(N9-INT(S(M,2)))

```

Figure F-2. Listing for Second File of Mini Refraction  
Sonde Program, 8 June 1978 (Page 5 of 8)





```

3995 PRINT 'TO LIST PER. RATIOS BEFOR GAP PROC'G, ENTR '**+' -- ';
4000 INPUT S$
4005 IF S$<>'+' THEN 4030
4010 PRINT @41:'TIME-TAGGED PERIOD RATIOS BEFORE GAP PROCESSING'
4015 PRINT @41:P
4020 PRINT 'CK DATA LIST & MAKE NEEDED CHANGES BEFOR CONTINUING RUN'
4025 STOP
4030 DIM P(3,400),R(3)
4035 RESTORE 4045
4037 REM:E8,E7,E6 ARE ALLOWED T,P,H TRENDS- RAT OF RAT PER FRAME
4038 REM:R IS # OF T-TAGS OF TREND = NOISE
4040 READ @34:E8,E7,E6,R
4045 DATA 1.003,1.003,1.32,14,14,3.3
4050 FOR M=1 TO 3
4055 PRINT ' ', 'START M=';M
4060 GO TO M OF 4065,4075,4085
4065 E9=E8
4070 GO TO 4090
4075 E9=E7
4080 GO TO 4090
4085 E9=E6
4090 REM:FIND FIRST RATIO IN EXPECTED RANGE
4095 N=1
4100 E3=P(M,N)
4105 IF E3-INT(E3)>0.1 AND E3-INT(E3)<0.95 THEN 4120
4110 N=N+1
4115 GO TO 4100
4120 E3=N
4125 N=N+1
4130 E4=P(M,N)
4135 E5=(E4-INT(E4))/(P(M,E3)-INT(P(M,E3)))
4140 E5=E5^(4/(INT(E4)-INT(P(M,E3))+R(M)))
4145 IF E5<E9 AND E5>1/E9 THEN 4290
4147 GO TO 4150
4148 PRINT @41:'INVALID SAMPLE - ';E4
4150 REM:RATIO CHANGE IS EXCESSIVE. FIND NEXT RATIO WITHIN CHANGE LIMIT
4155 PRINT ' ', 'E5=';E5
4160 S9=INT(P(1,P(1,400)))
4165 Z9=INT(P(3,P(3,400)))
4170 IF M=3 AND INT(E4)>S9 AND Z9-INT(E4)<20 THEN 4180
4175 GO TO 4190
4180 PRINT 'BAD HUM PAST TEMP END & WITHIN 2 SEC OF HUM END'
4185 GO TO 4245
4190 IF N<P(M,400) THEN 4375
4195 REM: TRAP AFTER STATEMENT 3120
4200 PRINT 'LOOK AT P(M,400)'S, ARE THEY OK'
4205 STOP
4210 GO TO 3122
4215 PRINT 'REACHED END OF FILE P(';M;'N). LAST OK SAMP=';P(M,E3)
4220 GO TO 4245
4225 L0=200
4230 L1=1925
4235 L2=1975

```

Figure F-2. Listing for Second File of Mini Refraction  
Sonde Program, 8 June 1978 (Page 7 of 8)



```

4240 GO TO 3120
4245 PRINT 'FOLLOWING SAMPS BEING DELETED:'
4250 N=E3
4255 N=N+1
4260 PRINT ' ', ' ', P(M,N)
4265 F(M,N)=0
4270 IF N=P(M,400) THEN 4280
4275 GO TO 4255
4280 F(M,400)=E3
4285 GO TO 4375
4290 REM:RATIO CHANGE IS WITHIN EXPECTED LIMITS
4292 REM:IS DATA TAGGED 'NO GOOD'
4293 IF E4-INT(E4)>0.99 OR E4-INT(E4)<0.05 THEN 4148
4295 IF E3=N-1 THEN 4370
4300 IF INT(E4)-INT(F(M,E3))<21 THEN 4320
4305 LIST 4300
4310 PRINT 'DATA GAP EXCEEDS 2 SEC. SHOULD IT BE RESTORED?'
4315 STOP
4320 PRINT 'DATA GAP <2 SEC BEING RESTORED'
4325 PRINT 'PRE-GAP VALUE =';P(M,E3)
4330 E3=E3+1
4335 PRINT 'P(';M;',';E3;') CHANGED FROM ';P(M,E3);' TO ';
4340 E2=E5^((INT(P(M,E3))-INT(P(M,E3-1)))/10)
4345 F(M,E3)=INT(P(M,E3))+P(M,E3-1)-INT(P(M,E3-1))*E2
4350 PRINT P(M,E3)
4355 IF E3=N-1 THEN 4365
4360 GO TO 4330
4365 PRINT 'POST-GAP RATIO = ';P(M,N)
4370 E3=N
4375 IF N=>P(M,400) THEN 4385
4380 GO TO 4125
4385 PRINT ' ', 'END M=';M
4390 NEXT M
4395 PRINT 'TO LIST PER. RATIOS AFTER GAP PROC'G, ENTR '+'' -- ';
4400 INPUT S$
4405 IF S$<>'+' THEN 4420
4407 PRINT @41:
4410 PRINT @41:'PERIOD RATIOS AFTER GAP PROCESSING'
4415 PRINT @41:P
4420 STOP
4425 REM:NOW IMPORT SOFTWARE FOR PROCESSING DATA FROM ARRAY.
4430 PRI 'LOAD 'SAFE' PROG CASS IN INTERNL UNIT. ENTR R WEN ROY -- ';
4435 INPUT S$
4440 IF S$='R' THEN 4450
4445 GO TO 4430
4450 FIND 3
4455 DELETE 100,4445
4460 APPEND 4750
4750 REM:PROG FILE 3 GETS APPENDED HERE

```

Figure F-2. Listing for Second File of Mini Refraction  
Sonde Program, 8 June 1978 (Page 8 of 8)



```

4750 REM:THIS PROG FROM FILE 3 APPENDS TO END OF PROG FROM FILE 2
4752 REM:ANALYZE DATA FROM INTERNAL FILE
4754 DELETE 100,4749
4756 PRINT "SELECT APP HUM SBRT(1=INTERP,2=EQN) -- ";
4758 INPUT F0
4760 REM:CALCULATE MB PRESSURE (Q9) AT LAUNCH ALT
4762 REM:INPUTS- PRESSURE ALT P1 (KFT), SURFACE PRESSURE P2 (MB)
4763 GO TO 4770
4764 Q9=(P2^0.190263-0.0256553*P1)^5.255883
4766 PRINT "CALC PRES FROM ALT= ";Q9;" MB"
4768 PRINT @41:"CALC PRES FROM ALT= ";Q9;" MB"
4770 PRINT "OPR-ENTERED EST OF SURF PRES= ";P2;" MB"
4772 PRINT @41:"OPR-ENTERED EST OF SURF PRES= ";P2;" MB"
4774 PRINT "ENTER EST OF VOLT REG TEMP T4 -- ";
4776 INPUT T4
4778 PRINT @41:"T4 = ";T4;" DEG C"
4779 GO TO 8530
5500 REM:CALCULATE TEMPS. T9=RES RATIO, T8=THIS APPARENT TEMP, T7=LAST
5502 REM:APP TEMP, T6=THIS TIME, T5=LAST TIME
5503 PRINT "STARTING TEMP CALCS"
5504 GO TO 5522
5506 REM:J0 & J1 ARE LAG COMP FACTORS FOR TEMP & HUM RANGING 0 TO 1
5508 RESTORE 5509
5509 DATA -99,0,0
5510 READ @34:T9,J0,J1
5511 PRINT "COMPS SET AT T: ";J0;" & H: ";J1;" WANT CHANGE? (1+/2-) - ";
5513 INPUT Z9
5514 GO TO Z9 OF 5516,5520
5515 GO TO 5511
5516 PRINT "ENTR COMP SETTINGS IN RANGE 0-1 (NONE-FULL) (T.TT H.HH)- ";
5517 INPUT J0,J1
5518 GO TO 5511
5520 PRINT @41:" LAG-COMP LEVELS ARE SET TO T: ";J0;" & H: ";J1
5522 FOR N=1 TO P(1,400)
5523 T9=P(1,N)-INT(P(1,N))
5525 T6=INT(P(1,N))
5530 IF T9>0.1 THEN 5560
5550 GO TO 5640
5560 REM:CALCULATE RES RATIO
5562 REM: WILL BYPASS THER RES RATIO CALC FOR BAROSWITCH DROPSONDE
5563 GO TO 5568
5565 T9=(52.718/T9-47.718)/R3
5568 T9=22.1*(1/(K0*T9)-1)/R3
5570 REM:CALCULATE APPARENT TEMP
5575 T8=65.3/(1-SQR(1-0.0480921*LOG(T9/3.3785E-4)))-273.16
5580 P(1,N)=INT(P(1,N))+T8/1000+0.1
5584 GO TO 5590
5585 PRINT "TIME-TAGGED APPARENT TEMP(MILLIDEG C)=";P(1,N)
5590 IF T7>-70 THEN 5615
5600 LIST 5590
5610 STOP
5615 GO TO 5670
5620 REM:LAG-COMP OF TEMP; J0=COMP-LEVEL SETTING (0-1; NONE-FULL)

```

Figure F-3. Listing for Third File of Mini Refraction  
Sonde Program, 8 June 1978 (Page 1 of 7)



```

5630 Z9=INT((T6+T5)/2+0.5)
5632 P(1,N-1)=Z9+0.1+1.0E-3*((T8+T7)/2+(T8-T7)/(T6-T5)*20*J0)
5634 GO TO 5640
5635 PRINT 'TAG: ';INT(P(1,N)), 'LC TEMP: ';(P(1,N)-INT(P(1,N))-0.1)*1000
5637 PRINT 1000*(P(1,N-1)-INT(P(1,N-1))-0.1)
5640 T7=T8
5650 T5=T6
5670 NEXT N
5671 GO TO 5700
5672 P(1,P(1,400))=0
5674 P(1,400)=P(1,400)-1
5680 PRINT 'END'
5690 STOP
5700 PRINT 'STARTING PRES CALCS'
5705 REM: OVERLAY P(2,N) ARRAY WITH PRES VALUES
5710 D7=1
5720 FOR N=1 TO P(2,400)
5730 D9=INT(P(1,N))
5740 D8=(P(1,N)-0.1-D9)*1000
5745 IF D8=999 THEN 5764
5750 GOSUB 8750
5760 P(2,N)=D9+1+P5/10000
5763 GO TO 5765
5764 P(2,N)=INT(P(2,N))+0.9999
5765 NEXT N
5770 PRINT 'END OF PRES CALC'
6000 REM:OVERLAY P(3,N) ARRAY WITH COMP HUM VALUES.
6020 REM:C9=LAST APP HUM, C8=LAST APP HUM TIME-TAG, C7=MEAN APP HUM
6040 REM:C3=MEAN TAG, C5= APP HUM RATE, C4=THIS APP HUM TIME TAG
6050 PRINT 'STARTING HUM CALCS'
6060 RESTORE 6100
6080 READ @34:C9,D7
6100 DATA 999,1
6160 FOR N=1 TO P(3,400)
6180 REM:CALC HUML RES RATIO R8
6200 R8=P(3,N)-INT(P(3,N))
6209 PRINT 'PER RATIO = ';R8;
6210 IF R8=0 THEN 6860
6215 REM: WILL BYPASS HUML RES RATIO CALC FOR BAROSWITCH DROPSONDE
6217 GO TO 6235
6220 R8=52.718/R8-47.718-7.1
6230 R8=250*R8/(250-R8)/R4
6235 R8=249*(18.2-R8*K0*25.35)/(K0*R8*274.35-18.2)/R4
6239 PRINT ' RES RATIO=';R8
6240 REM:FETCH CORRESPONDING COMP TEMP T6 FOR APP HUM CALC
6260 C4=INT(P(3,N))
6270 D9=C4-2
6279 PRINT 'TIME TAG= ';C4;
6280 D8=(P(1,N)-0.1-D9)*1000
6281 PRINT ' TEMP=';D8;
6300 T6=D8
6320 REM:CALC APP HUM
6330 GO TO FO OF 6340,6350

```

Figure F-3. Listing for Third File of Mini Refraction  
Sonde Program, 8 June 1978 (Page 2 of 7)



```

6332 LIST 6330
6335 STOP
6340 GOSUB 8000
6345 GO TO 6357
6350 GOSUB 8600
6355 PRINT '    APP H=';H9
6357 GO TO 6845
6360 IF C9>101 OR H9=999 THEN 6370
6365 GO TO 6380
6370 IF N<=1 THEN 6800
6375 P(3,N-1)=INT(P(3,N-1))+0.999
6377 GO TO 6800
6380 REM:CAL MEAN AP HUM C7, MEAN-TAG TEMP C6 & HUM RATE C5 FOR HUM SEG
6400 C7=(H9+C9)/2
6420 C3=INT((C4+C8)/2+0.5)
6440 C5=(H9-C9)/(C4-C8)*10
6460 REM:FETCH COMP TEMP C6 FOR TIME-TAG C3
6480 D9=C3
6499 PRINT 'TIME=';D9/10;
6500 GOSUB 7000
6501 PRINT '    TEMP=';D8;
6502 IF D8<999 THEN 6520
6504 IF C3-INT(P(1,P(1,400)))>0 AND C3-INT(P(1,P(1,400)))<=4 THEN 6510
6506 GO TO 6520
6510 PRINT 'TAG IS WITHIN 4 SEC OF TEMP END. LAST TEMP WILL BE USED'
6512 D8=C6
6514 PRINT '    TEMP=';D8
6520 C6=D8
6540 GOSUB 9000
6541 PRINT '    ', 'COMP H=';G6
6545 IF G6<=100 THEN 6560
6549 LIST 6545
6550 PRINT 'COMP HUM CHANGED FROM ';G6;' TO 100; TIME TAG= ';C6
6560 P(3,N-1)=C3+1.0E-3*(G6 MIN 100)
6800 REM:SET-UP FOR PROCESSING NEXT N
6820 C9=H9
6840 C8=C4
6845 REM:WRITE BALLOON HUM
6850 P(3,N)=D9+2+H9/1000
6860 NEXT N
6870 GO TO 6940
6880 P(3,P(3,400))=0
6900 P(3,400)=P(3,400)-1
6920 PRI 'COMP HUM VALUES HAVE BEEN STORED IN REDUCED DATA FILE P(3,N)'
6940 PRINT @41:P
6960 GO TO 9100
7000 REM:APPEND TEMP-FETCH HERE
7020 REM:FETCH COMP-TEMP D8 FOR TIMETAG D9 USING POINTER D7
7021 GO TO 7040
7022 IF INT(P(1,1))<=D9 AND INT(P(1,P(1,400)))=>D9 THEN 7040
7024 PRINT 'TIME-TAG D9 (';D9;) IS OUTSIDE LIMITS OF REDUCED TEMP DATA'
7026 D8=999
7028 GO TO 7360

```

Figure F-3. Listing for Third File of Mini Refraction  
Sonde Program, 8 June 1978 (Page 3 of 7)



```

7040 IF D7=>1 AND D7<=P(1,400) THEN 7080
7050 IF D7<>0 THEN 7080
7060 D8=999
7070 GO TO 7360
7080 D8=INT(P(1,D7))
7100 IF D8<>D9 THEN 7160
7120 D8=1000*(P(1,D7)-0.1-D8)
7140 GO TO 7360
7160 IF D8<D9 THEN 7220
7180 D7=D7-1
7200 GO TO 7040
7220 D7=D7+1
7240 D8=INT(P(1,D7))
7260 IF D8=D9 THEN 7120
7280 IF D8>D9 THEN 7320
7300 GO TO 7220
7320 D8=(D9-INT(P(1,D7-1)))/(D8-INT(P(1,D7-1)))
7340 D8=D8*(P(1,D7)-INT(P(1,D7))-(P(1,D7-1)-INT(P(1,D7-1))))
7350 D8=1000*(P(1,D7-1)-INT(P(1,D7-1))-0.1+D8)
7360 RETURN
8000 REM:CALC %RH-INPUT COMP TEMP T6 & HUMID RATIO R9; OUTPUT %RH H9
8001 IF T6<>999 THEN 8005
8002 H9=999
8003 GO TO 8515
8005 DATA 0.52,0.62,0.74,0.82,0.9,1.1,1.3,1.63,2.23
8010 DATA 3.1,4.2,6.5,10.2,17,29,45,45,45,45,45
8015 DATA 0.55,0.65,0.78,0.85,0.92,1.06,1.23,1.4,1.75
8020 DATA 2.35,3.1,4.1,6,9.8,17,26,44,86,170,250
8025 DATA 0.585,0.695,0.8,0.875,0.94,1.05,1.175,1.32,1.58
8030 DATA 2,2.5,3.25,4.5,7.3,12,18.5,29,60,140,220
8035 DATA 0.61,0.72,0.82,0.89,0.95,1.04,1.15,1.27,1.47
8040 DATA 1.85,2.3,3,4,6.4,10,16,23,40,126,206
8045 H1=0
8050 H2=0
8055 H3=0
8060 H4=0
8065 IF T6=>-40 AND T6<0 THEN 8075
8070 GO TO 8090
8075 RESTORE 8005
8080 H1=999
8085 GOSUB 8290
8090 IF T6=>-40 AND T6<25 THEN 8100
8095 GO TO 8115
8100 RESTORE 8015
8105 H2=999
8110 GOSUB 8290
8115 IF T6>0 AND T6<40 THEN 8125
8120 GO TO 8140
8125 RESTORE 8025
8130 H3=999
8135 GOSUB 8290
8140 IF T6>25 AND T6<=40 THEN 8150
8145 GO TO 8165

```

Figure F-3. Listing for Third File of Mini Refraction  
Sonde Program, 8 June 1978 (Page 4 of 7)



```

8150 RESTORE 8035
8155 H4=999
8160 GOSUB 8290
8165 IF T6<-40 OR T6>40 THEN 8175
8170 GO TO 8190
8175 LIST 8165
8180 PRINT 'T6= ';T6,' - TILT!!! TEMP EXCEEDS HYG RATIO LIMITS'
8181 PRINT 'WILL SET H9=999 & RETURN'
8182 GO TO 8002
8185 STOP
8190 REM:TEMP INTERPOLATION OF RH BEGINS HERE
8195 IF H1>0 AND H2=0 AND H3=0 AND H4=0 THEN 8455
8200 IF H1=0 AND H2>0 AND H3=0 AND H4=0 THEN 8465
8205 IF H1=0 AND H2=0 AND H3>0 AND H4=0 THEN 8475
8210 IF H1=0 AND H2=0 AND H3=0 AND H4>0 THEN 8485
8215 IF H1>0 AND H2>0 AND H3=0 AND H4=0 THEN 8225
8220 GO TO 8235
8225 H9=H1+(H2-H1)*(T6+40)/40
8230 GO TO 8495
8235 IF H1=0 AND H2>0 AND H3>0 AND H4=0 THEN 8245
8240 GO TO 8255
8245 H9=H2+(H3-H2)*T6/25
8250 GO TO 8495
8255 IF H1=0 AND H2=0 AND H3>0 AND H4>0 THEN 8265
8260 GO TO 8275
8265 H9=H3+(H4-H3)*(T6-25)/15
8270 GO TO 8495
8275 LIST 8255
8280 PRINT 'PROGRAMMED STOP'
8285 STOP
8290 REM:INTERPOLATE RATIO TO GET HUM; PUT HUM IN PLACE OF 999 VALUE
8295 H7=5
8300 READ @34:H8
8305 IF R8=>H8 THEN 8320
8310 H5=9.9
8315 GO TO 8370
8320 H7=H7+5
8325 IF H7<=105 THEN 8345
8330 LIST 8325
8335 PRINT 'HYGR RATIO EXCEEDS LIMITS, (=';R8;')'
8340 GO TO 8002
8345 H6=H8
8350 READ @34:H8
8355 IF R8>H8 THEN 8320
8360 REM:R8 IS IN RANGE OF H6 - H8; WILL INTERPOLATE RATIO TO GET HUM
8365 H5=H7+5*(R8-H6)/(H8-H6)
8370 REM:REPLACE999 WITH H5 THEN RETURN
8375 IF H1=999 AND H2<106 AND H3<106 AND H4<106 THEN 8410
8380 IF H1<106 AND H2=999 AND H3<106 AND H4<106 THEN 8420
8385 IF H1<106 AND H2<106 AND H3=999 AND H4<106 THEN 8430
8390 IF H1<106 AND H2<106 AND H3<106 AND H4=999 THEN 8440
8395 LIST 8390
8400 PRINT 'PROGRAMMED STOP'

```

Figure F-3. Listing for Third File of Mini Refraction  
Sonde Program, 8 June 1978 (Page 5 of 7)



```

8405 STOP
8410 H1=H5
8415 GO TO 8450
8420 H2=H5
8425 GO TO 8450
8430 H3=H5
8435 GO TO 8450
8440 H4=H5
8445 GO TO 8450
8450 RETURN
8455 H9=H1
8460 GO TO 8495
8465 H9=H2
8470 GO TO 8495
8475 H9=H3
8480 GO TO 8495
8485 H9=H4
8490 GO TO 8495
8495 IF H9<=100 THEN 8515
8500 PRINT 'APP HUM CHANGED FROM ';H9;' TO 100; TIME-TAG=';INT(P(3,N))
8505 H9=100
8510 REM:THIS PROG MODIFIED, DEBUGGED & WORKING AT SBRT LEVEL. MCW7708
8515 RETURN
8530 PRINT 'SEL CALC MODE(1=CALC & DISP T,P,H; 2=CALC ALL T,P,H) ';
8532 INPUT F1
8534 IF F1=2 THEN 5500
8536 PRINT 'SELECT TIME TAG (MUST BE =< MAX TIME TAG-2)';
8538 INPUT D9
8540 REM: SBRT WILL RETRIEVE TEM PER RAT D8 OF SPEC TIME TAG
8542 D7=1
8544 GOSUB 7000
8545 D8=D8/1000+0.1
8546 T9=22.1*(1/(K0*D8)-1)/R3
8548 T8=65.3/(1-SQR(1-0.0480921*LOG(T9/3.3785E-4)))-273.16
8550 D8=T8
8551 N=D7
8552 GOSUB 8750
8554 R8=P(3,N)-INT(P(3,N))
8556 R8=249*(18.2-R8*K0*25.35)/(K0*R8*274.35-18.2)/R4
8558 T6=T8
8560 GOSUB 8600
8562 PRINT 'TIME TAG, TEMP, PRES, HUM= ';D9;' ';T8;' ';P5;' ';H9
8564 PRINT @41:'TIME TAG, TEMP, PRES, HUM= ';D9;' ';T8;' ';P5;' ';H9
8566 PRINT @41:'PRES COEF L(3,6) ARE AS FOLLOWS:'
8568 PRINT @41:L
8570 GO TO 8530
8600 REM: CALC APP HUM H9 FROM HUML RATIO R8 AND TEMP T6 DEG C.
8605 IF R8=>1 THEN 8625
8610 GOSUB 8640
8615 H9=33-H0
8620 GO TO 8700
8625 GOSUB 8660
8630 H9=33+H0

```

Figure F-3. Listing for Third File of Mini Refraction  
Sonde Program, 8 June 1978 (Page 6 of 7)



```

8635 GO TO 8700
8640 REM: ENTRY POINT FOR R8<1
8645 B9=20
8650 R9=1/R8
8655 GO TO 8675
8660 REM: ENTRY POINT FOR R8=>1
8665 B9=15
8670 R9=R8
8675 A9=0.02*T6+3.2
8680 K9=0.9-(0.001425*T6+0.25)*LGT(LGT(R9)+1)^0.333333333333
8685 H0=A9*LOG(R9^B9)^K9
8690 RETURN
8695 REM: THIS SBRT TESTED & DEBUGGED 780213 FK-MCW
8700 RETURN
8750 REM: CALC PRES
8760 REM: INPUTS-K0=REF CONST, P(2,N)=PRES PER RAT, D8=COM TEMP
8770 REM: INPUTS-COEF IN L ARRAY
8780 REM: OUTPUT-PRES P5 (MB)
8790 REM: CALC SUPPLY VOLTS V0
8800 V0=7.629+0.0076*T4
8810 G0=L(1,1)+L(1,2)*V0+L(1,3)*V0^2
8820 G2=L(2,1)+L(2,2)*V0+L(2,3)*V0^2
8830 G4=L(3,1)+L(3,2)*V0+L(3,3)*V0^2
8840 D8=D8+273.16
8850 G1=L(1,4)+L(1,5)*D8+L(1,6)*D8^2
8860 G3=L(2,4)+L(2,5)*D8+L(2,6)*D8^2
8870 G5=L(3,4)+L(3,5)*D8+L(3,6)*D8^2
8880 D8=D8-273.16
8890 V1=V0*(P(2,N)-INT(P(2,N)))*K0
8900 P5=G0*G1+G2*G3*V1+G4*G5*V1^2
8910 RETURN
9000 REM:LAG-COMP HUM. INPUTS- HUM C7, TEMP C6, HUM RATE C5; OUTPUT G6
9001 REM:J1=HUM LAG-COMP SETTING (0-1; NONE-FULL)
9005 IF C5<0 THEN 9020
9010 G6=0.17*(273.16/(C6+273.16))+0.36*(273.16/(C6+273.16))^17
9015 GO TO 9025
9020 G6=0.2*(273.16/(C6+273.16))+0.75*(273.16/(C6+273.16))^19.3
9025 G6=C7+G6*C5*J1
9030 REM:END OF HYGRISTOR LAG-COMPENSATION PROG
9035 RETURN
9100 STOP
9110 PRINT 'SAFE PROG CASS IN CONSOL . WEN RDY FOR FILE 4, ENTR R - *';
9120 INPUT S$
9130 IF S$='R' THEN 9145
9140 GO TO 9110
9145 DELETE L
9150 FIND 4
9160 DELETE 4750,6960
9170 DELETE 8000,9145
9180 APPEND 9200
9190 REM: MODIFIED FOR CONTINUOUS PRESSURE SENSOR, FK-780216
9192 REM: MODIFICATION- CALC OF THERM AND HUML RES RATIOS
9200 REM:FILE 4 GETS APPENDED HERE

```

Figure F-3. Listing for Third File of Mini Refraction  
Sonde Program, 8 June 1978 (Page 7 of 7)



```

9200 REM:FILE4. TO BE APPENDED TO FILE 3 AT LINE 9200
9210 DELETE 9150,9180
9220 GO TO 50000
9590 REM:CALC ALTITUDE,REFRACTIVITY PROFILE INT(P(2,N))
9600 REM:MAKE SURE INT(P(2,N)) ARE ALL 0
9615 FOR N=1 TO 399
9620 P(2,N)=P(2,N)-INT(P(2,N))
9625 NEXT N
9650 REM:FETCH SURFACE PRES
9660 V9=10000*(P(2,P(2,400))-INT(P(2,P(2,400))))
9670 REM:CALC LAYER THICKNESSES, INT(P(2,N)) CENTIFEET, V9=BOTTOM PRES,
9680 REM:V8=TOP PR, V7=AVG RH, V6=AVG TEMP, V5=SAT VAP PR, V4=THKNS (M)
9684 REM: ENTER SURF ALT IN P-ARRAY WITH SURF PRES
9686 P(2,P(2,400))=P(2,P(2,400))+INT(P1*100/0.3048+0.5)
9690 FOR N=P(2,400) TO 1 STEP -1
9700 REM:FETCH TOP PRES
9710 V8=P(2,400)
9720 V8=V8-1
9730 IF INT(P(1,V8)+1)<INT(P(1,N)+1) AND V8>1 THEN 9770
9740 IF V8>1 THEN 9720
9742 IF V8<>1 THEN 9750
9744 PRINT "REACHED END OF PRES FILE WITH ";N;" LAYER(S) NOT CALCULATED"
9746 GO TO 9940
9750 LIST 9740
9760 STOP
9770 Z9=INT(P(1,V8+1))-INT(P(1,V8))
9775 V8=10000*(P(2,V8)-INT(P(2,V8)))
9780 I7=(V9-V8)/Z9
9785 V9=V9+I7
9790 V8=V8+I7
9792 IF V8<V9 THEN 9800
9793 GO TO 9800
9794 LIST 9792
9796 PRINT "TOP PR=";V8,"BOTTOM PR=";V9
9798 STOP
9800 REM:CALC AVG RH
9810 V7=500*(P(3,N-1)-INT(P(3,N-1))+P(3,N)-INT(P(3,N)))
9820 REM:FETCH AVG TEMP V6
9830 D9=(INT(P(3,N-1))+INT(P(3,N)))/2
9840 GOSUB 7000
9850 V6=D8
9860 REM:CALC SAT VAP PRES V5 USING V6
9870 GOSUB 15000
9880 REM:CALC THICKNESS V4 & INCREMENT ALTITUDE INT(P(2,N))
9890 V4=28.8*(V6+273.16)*(V9*V8)^0.5
9900 V4=V4/(0.18*V7*V5+28.8*((V9*V8)^0.5-0.01*V7*V5))
9910 V4=-29.263242*V4*(LOG(V8/1000)-LOG(V9/1000))
9912 IF V4>0 THEN 9920
9913 GO TO 9920
9914 LIST 9912
9916 PRINT "THKNS=";V4,"N=";N
9918 STOP
9920 P(2,N-1)=INT(P(2,N))+INT(100*V4/0.3048+0.5)+P(2,N-1)-INT(P(2,N-1))

```

Figure F-4. Listing for Fourth File of Mini Refraction  
Sonde Program, 8 June 1978 (Page 1 of 10)



```

9925 V9=V8-I7
9930 NEXT N
9940 PRINT 'WANT CENTIFT ALTS CORRESPND'G TO HUM VALUES? 1(+), 2(-) - ';
9950 INPUT Z9
9960 GO TO Z9 OF 9980,10000
9970 GO TO 9940
9980 PRINT @41:'FOLLOWING ARE LISTS OF TAG,TEMP, ALT.PRES, TAG.HUM:'
9990 PRINT @41:P
10000 REM:CALC REFRACTIVITIES & STORE IN INT(P(3,N))
10002 FOR N=1 TO 399
10004 P(3,N)=P(3,N)-INT(P(3,N))
10006 NEXT N
10010 FOR N=1 TO P(3,400)
10040 REM:FETCH TEMP D8 AT TAG D9
10050 D8=(P(1,N)-0.1-INT(P(1,N)))*1000
10060 V6=D8
10070 REM:CALC SAT VAP PRES V5 FOR TEMP V6
10080 GOSUB 15000
10090 REM:FETCH PRES V8 MB FOR TAG D9
10105 IF P(2,N)=0 AND N<>P(3,400) THEN 10160
10110 V8=(P(2,N)-INT(P(2,N)))*10000
10115 IF V8=9999 THEN 10160
10120 REM:CALC REFR'Y N-UNITS, V4
10125 Z9=1000*(P(3,N)-INT(P(3,N)))
10130 V4=(77.6*V8-0.056*Z9*V5)/(D8+273.16)
10140 V4=V4+3750*Z9*V5/(D8+273.16)^2
10150 P(3,N)=P(3,N)+INT(V4*1000+0.5)
10160 NEXT N
10170 PRINT 'WANT LIST OF ALT AND N UNITS? 1(+) OR 2(-) -- ';
10180 INPUT Z9
10190 GO TO Z9 OF 10210,10230
10200 GO TO 10170
10210 PRINT @41:'FOLLOWING ARE LISTS OF TAG,T, ALT,P, N,H:'
10220 PRINT @41:P
10230 GO TO 21000
15000 REM:CALC SAT VAP PR V5 MB FOR TEMP V6 DEG C; Z9=(1-t)/t
15010 Z9=(1-(V6+273.16)/373.16)/((V6+273.16)/373.16)
15020 V5=1013.246*10^(0.0081238*(10^(-3.49149*Z9)-1))
15030 Z8=(V6+273.16)/373.16
15040 V5=V5/(Z8^5.02808*10^(7.90298*Z9))
15050 V5=V5/10^(1.3816E-7*(10^(11.344*(1-Z8))-1))
15060 RETURN
20000 REM:FETCH PRES V8 MB FOR TAG D9
20005 D9=D9+1
20010 IF D9=>INT(P(1,1)+1) AND D9<=INT(P(1,P(2,400))+1) THEN 20060
20020 LIST 20010 .
20030 PRINT 'TAG=';D9;' & IS OUTSIDE TAG RANGE FOR PRES FILE'
20035 PRINT 'NON-VALID CODE ''9999'' APPLIED TO PRES V8 (AT N=';N;')'
20040 V8=9999
20045 GO TO 20170
20060 Z9=1
20070 Z9=Z9+1
20080 IF INT(P(1,Z9)+1)=>D9 THEN 20140

```

Figure F-4. Listing for Fourth File of Mini Refraction  
Sonde Program, 8 June 1978 (Page 2 of 10)



```

20090 GO TO 20070
20140 V8=(D9-INT(P(1,Z9-1)+1))/(INT(P(1,Z9)+1)-INT(P(1,Z9-1)+1))
20150 V8=V8*(P(2,Z9)-INT(P(2,Z9))-(P(2,Z9-1)-INT(P(2,Z9-1))))
20160 V8=10000*(P(2,Z9-1)-INT(P(2,Z9-1))+V8)
20165 D9=D9-1
20170 RETURN
21000 REM:LIST FT,M,MB,DEG-C,%RH,N,M-UNITS,G/M3,D-PT-DEF,N/M,N/M-CLASS
21002 PRINT @41:
21004 PRINT @41:
21006 PRINT @41: ' ', 'DETAILED LIST OF ATMOSPHERIC PARAMETERS'
21008 PRINT @41:
21010 PRINT @41: 'ALT(FT)  ALT(M)  PR(MB)  T(DEG-C)  RH(%)  N-UNITS  ';
21020 PRINT @41: ' M-UNITS  G/M3  D-PT-DEF  N/M  N/M-CLASS'
21030 Z$=' -----'
21040 PRINT @41: Z$; Z$; ' -----'
21050 REM: W9=NTH VALUE OF ALT(FT), W8=NTH VALUE OF REFR'Y
21060 FOR N=1 TO P(3,400)
21070 W9=0.01*INT(P(2,N))
21072 IF W9=0 AND N<P(3,400) THEN 21400
21080 W8=INT(P(3,N))/1000
21110 REM: FETCH PR V8 MB FOR TAG D9
21130 V8=(P(2,N)-INT(P(2,N)))*10000
21132 IF V8=9999 THEN 21400
21140 REM: FETCH TEMP D8 DEG C FOR TAG D9
21150 D8=(P(1,N)-0.1-INT(P(1,N)))*1000
21170 W1=1000*(P(3,N)-INT(P(3,N)))
21180 GOSUB 21420
21190 IMAGE6D,X,6D,X,5D,DX,4D,2DX,5D,DX,5D,DX,6D,X,4D,2DX,5D,DX
21200 PRINT @41: USING 21190: W9; 0.3048*W9; V8; D8; W1; W8; W8+0.048*W9; W2; W3
21210 IF N=P(3,400) THEN 21400
21220 W7=0.01*INT(P(2,N+1))
21230 W6=INT(P(3,N+1))/1000
21240 REM: CALC N/M GRAD W5
21250 W5=(W8-W6)/(W9-W7)/0.3048
21280 IF W5<-0.07874 THEN 21340
21290 IF W5<0 THEN 21320
21300 W$=' SUBFR+ '
21310 GO TO 21390
21320 W$=' NORML- '
21330 GO TO 21390
21340 IF W5<-0.1575 THEN 21380
21360 W$=' SPRF-- '
21370 GO TO 21390
21380 W$=' TRF--- '
21390 PRINT @41: USING '74D,4DX,8A': W5; W$
21400 NEXT N
21410 GO TO 21580
21420 REM: CALC ABS HUM W2 GRAMS/CUBIC-M AND DEW POINT DEF W3 DEG C
21425 REM: FIRST CALC W2
21430 V6=D8
21440 GOSUB 15000
21450 W2=596*10*(P(3,N)-INT(P(3,N)))*V6/1013.25*373.16/(D8+273.16)
21455 REM: ENTR SBRT HERE IF W2 IS KNOWN & ONLY W3 IS WANTED

```

Figure F-4. Listing for Fourth File of Mini Refraction  
Sonde Program, 8 June 1978 (Page 3 of 10)



```

21460 REM:NOW CALC DEW-POINT DEF W3
21470 V6=D8
21480 GOSUB 15000
21490 W4=0.01*(1000*(P(3,N)-INT(P(3,N))))*V5
21500 V4=V5
21510 V6=D8-1
21520 GOSUB 15000
21530 IF ABS(V5-W4)<1.0E-3*W4 THEN 21560
21540 V6=D8-(D8-V6)*(V4-W4)/(V4-V5)
21550 GO TO 21520
21560 W3=D8-V6
21570 RETURN
21580 LIST 21600
21585 PRINT 'IF WANT COPY DISPLAY, DO SO BEFOR CONTINUING RUN'
21590 STOP
21600 REM:END OF PRINTOUT; WILL GO TO PLOT.
30000 REM:PLOT ALTITUDE PROFILES OF TEMP & HUM
30005 PAGE
30010 REM:SELECT ALT SCALE
30011 N=1
30012 U0=0
30014 U0=U0 MAX INT(P(1,N))+1
30015 IF U0>INT(P(1,N))+1 THEN 30020
30017 N=N+1
30018 GO TO 30014
30020 IF 0.01*U0>15000 THEN 30050
30030 U0=15000
30040 GO TO 30095
30050 U0=30000
30095 REM:PLOT TEMP AXES
30100 VIEWPORT 5,75,5,95
30110 WINDOW -40,30,-500,U0
30120 AXIS 5,U0/15,-40,0
30130 MOVE -40,U0
30140 PRINT 'KHHKFT', 'TEMP( DEG C)', ' ', 'RH(%)'
30150 PRINT U0/1000, ' ', 'HIDROP #';NO;'JHHHHHHH';D1
30160 MOVE -40,2*U0/3
30170 PRINT 'HH';2*U0/3000
30180 MOVE -40,U0/3
30190 PRINT 'HH';U0/3000
30200 MOVE -40,0
30210 PRINT 'H0'
30220 MOVE 0,-500
30230 PRINT 'JOK'
30240 MOVE -20,-500
30250 PRINT 'JHH-20K'
30260 MOVE 20,-500
30270 PRINT 'JH20K'
30280 REM:PLOT TEMPS
30290 D7=1
30300 FOR N=2 TO P(3,400)
30320 D8=(P(1,N-1)-0.1-INT(P(1,N-1)))*1000
30325 D0=0.01*INT(P(2,N-1))

```

Figure F-4. Listing for Fourth File of Mini Refraction  
Sonde Program, 8 June 1978 (Page 4 of 10)



```

30330 IF ABS(D8)>60 OR D0=0 THEN 30390
30340 MOVE D8,D0
30360 D8=(P(1,N)-0.1-INT(P(1,N)))*1000
30365 D0=0.01*INT(P(2,N))
30370 IF ABS(D8)>60 OR D0=0 THEN 30390
30380 DRAW D8,D0
30390 NEXT N
30395 REM:PLOT HUM AXES
30400 VIEWPORT 77,127,5,95
30410 WINDOW 0,100,-500,U0
30420 AXIS 10,U0/15
30430 MOVE 0,-500
30440 PRINT "J0K"
30450 MOVE 50,-500
30460 PRINT "JH50K"
30470 MOVE 100,-500
30480 PRINT "JHH100K"
30490 REM:PLOT HUMS
30500 FOR N=2 TO P(3,400)
30510 D9=1000*(P(3,N-1)-INT(P(3,N-1)))
30515 D0=0.01*INT(P(2,N-1))
30520 IF D9>100 OR D0=0 THEN 30570
30530 MOVE D9,D0
30540 D9=1000*(P(3,N)-INT(P(3,N)))
30545 D0=0.01*INT(P(2,N))
30550 IF D9>100 OR D0=0 THEN 30570
30560 DRAW D9,D0
30570 NEXT N
30574 COPY
30576 FOR N=1 TO 2200
30578 NEXT N
30580 COPY
30582 FOR N=1 TO 2200
30583 NEXT N
30584 COPY
30586 PAGE
40000 REM:PLOT ALTITUDE PROFILES OF N- & M-UNITS
40050 VIEWPORT 5,75,5,95
40060 WINDOW 200,400,-500,U0
40070 AXIS 20,U0/15,200,0
40080 MOVE 200,U0
40090 PRINT "KHKFT", "REFR'Y(N-UNITS)", " ", "M-UNITS"
40100 PRINT U0/1000, " ", "HIDROP #";NO;"JHHHHHHH";D1
40110 MOVE 200,2*U0/3
40120 PRINT "HH";2*U0/3000
40130 MOVE 200,U0/3
40140 PRINT "HH";U0/3000
40150 MOVE 200,0
40160 PRINT "H0"
40170 MOVE 300,-500
40180 PRINT "JH300K"
40190 MOVE 240,-500
40200 PRINT "JH240K"

```

Figure F-4. Listing for Fourth File of Mini Refraction  
Sonde Program, 8 June 1978 (Page 5 of 10)



```

40210 MOVE 360,-500
40220 PRINT 'JH360K'
40230 REM:PLOT N-UNITS
40240 D7=1
40250 FOR N=2 TO P(3,400)
40260 D8=INT(P(3,N-1))/1000
40270 D0=0.01*INT(P(2,N-1))
40280 IF ABS(D8-600)>400 OR D0=0 THEN 40340
40290 MOVE D8,D0
40300 D8=INT(P(3,N))/1000
40310 D0=0.01*INT(P(2,N))
40320 IF ABS(D8-600)>400 OR D0=0 THEN 40340
40330 DRAW D8,D0
40340 NEXT N
40350 VIEWPORT 77,127,5,95
40360 WINDOW 300,900,-500,U0
40370 AXIS 100,U0/15,300,0
40380 MOVE 300,-500
40390 PRINT 'JH300K'
40400 MOVE 600,-500
40410 PRINT 'JH600K'
40420 MOVE 900,-500
40430 PRINT 'JHH900K'
40440 REM:PLOT M-UNITS
40450 FOR N=2 TO P(2,400)
40460 D9=INT(P(3,N-1))/1000
40465 D9=D9+0.048*0.01*INT(P(2,N-1))
40467 D0=0.01*INT(P(2,N-1))
40470 IF ABS(D9-600)>390 OR D0=0 THEN 40520
40480 MOVE D9,D0
40490 D9=INT(P(3,N))/1000
40495 D9=D9+0.048*0.01*INT(P(2,N))
40497 D0=0.01*INT(P(2,N))
40500 IF ABS(D9-600)>390 OR D0=0 THEN 40520
40510 DRAW D9,D0
40520 NEXT N
40522 COPY
40524 FOR N=1 TO 2200
40526 NEXT N
40528 COPY
40530 FOR N=1 TO 2200
40532 NEXT N
40534 COPY
40536 PAGE
45000 REM:LIST SIGNIF LEVELS (BASED ON LINEAR FIT OF T&H TO ALT)
45002 PRINT @41:
45003 PRINT @41:
45005 PRI @41:' ','SIGNIF LEVS (T1,H10) LIST OF ATMOSPHERIC PARAMETERS'
45007 PRINT @41:
45010 DELETE S
45020 DIM S(2,9),O(9)
45030 RESTORE 45050
45040 READ @34:S9,S8,S,O,M

```

Figure F-4. Listing for Fourth File of Mini Refraction  
Sonde Program, 8 June 1978 (Page 6 of 10)



```

45050 DATA 2,0,1.0E-3,0,-9.0E+99,9.0E+99,0,0,0,0,0,0,0.01,0,-9.0E+99
45055 DATA 9.0E+99,0,0,0,0,0,9.0E+99,0,0,0,0,0,0,0,0,1
45060 REM:LIST FT,M,MB,DEG-C,%RH,N,M-UNITS,G/M3,I-PT-DEF
45070 PRINT @41:"ALT(FT) ALT(M) PR(MB) T(DEG-C) RH(%) N-UNITS ";
45080 PRINT @41:" M-UNITS G/M3 I-PT-DEF"
45090 Z$=" ----- "
45100 PRINT @41:Z$;Z$;" -----"
45110 REM:W9=NTH VALUE OF ALT(FT), W8=NTH VALUE OF REFR'Y
45120 FOR N=P(2,400) TO 2 STEP -1
45130 W9=0.01*INT(P(2,N))
45150 W8=INT(P(3,N))/1000
45160 REM:FETCH PR V8 MB FOR TAG I9
45180 V8=(P(2,N)-INT(P(2,N)))*10000
45190 IF V8=9999 THEN 45500
45200 REM:FETCH TEMP I8 DEG C FOR TAG I9
45210 I8=(P(1,N)-0.1-INT(P(1,N)))*1000
45220 W1=1000*(P(3,N)-INT(P(3,N)))
45222 REM:CALC ABS HUM W2 & DEW-PT-DEF W3
45224 GOSUB 21420
45230 P9=1.1+I8/1000
45240 N9=100*W9+1.0E-3
45250 IF N9=1.0E-3 AND INT(S(M,9))=0 AND INT(S(M,2))>0 THEN 45500
45260 GOSUB 45520
45270 P9=2+W1/1000
45280 GOSUB 45520
45285 IF N=1 THEN 45300
45290 IF S8<>1 THEN 45340
45300 S8=0
45320 IMAGE6D,X,6D,X,5D,DX,4D,2DX,5D,DX,5D,DX,6D,X,4D,2DX,5D,DX
45330 PRINT @41: USING 45320:D
45340 O(1)=W9
45350 O(2)=0.3048*W9
45360 O(3)=V8
45370 O(4)=I8
45380 O(5)=W1
45390 O(6)=W8
45400 O(7)=W8+0.048*W9
45410 O(8)=W2
45420 O(9)=W3
45500 NEXT N
45510 GO TO 49000
45520 REM:FIND SIGNIFICANT VALUES
45530 REM:INPUT IS ID-TAGGED VALUE P9 & LINEARITY BASE N9
45540 REM:INPUT TOLERANCES ARE S(M,1)
45550 REM:OUTPUTS:BASE-TAGGED VALUES S(M,2) WITH FLAG S8=1 WEN SIGNIF
45560 M=INT(P9)
45570 REM:CALCULATE NEW SLOPE S(M,5)
45580 S(M,5)=(P9-INT(P9)-(S(M,2)-INT(S(M,2))))/(N9-INT(S(M,2)))
45660 REM:TEST NEW SLOPE
45665 IF N<=2 THEN 45690
45670 IF S(M,5)=>S(M,3) AND S(M,5)<=S(M,4) THEN 45692
45680 REM:NEW SLOPE NOT OK; SET FLAG
45690 S8=1

```

Figure F-4. Listing for Fourth File of Mini Refraction  
Sonde Program, 8 June 1978 (Page 7 of 10)



```

45692 REM:UPDATE LAST LEVEL
45694 S(M,8)=S(M,9)
45696 S(M,9)=INT(N9)+(P9-INT(P9))
45700 IF M<S9 THEN 45930
45720 REM:FOR ALL M, DECLARE LAST VALUE IF SIGNIF, SET NEW LIMITS
45730 FOR M=1 TO S9
45735 IF S8<>1 THEN 45762
45740 S(M,2)=S(M,8)
45750 S(M,3)=-9.0E+99
45760 S(M,4)=9.0E+99
45762 REM:CALCULATE NEW ACCEPTANCE SLOPE LIMITS
45764 IF N9>INT(S(M,2)) THEN 45772
45766 S(M,6)=S(M,9)-INT(S(M,9))+S(M,1)-(S(M,2)-INT(S(M,2)))
45767 S(M,6)=S(M,6)/(N9-INT(S(M,2)))
45768 S(M,7)=S(M,9)-INT(S(M,9))-S(M,1)-(S(M,2)-INT(S(M,2)))
45769 S(M,7)=S(M,7)/(N9-INT(S(M,2)))
45770 GO TO 45780
45772 S(M,6)=S(M,9)-INT(S(M,9))-S(M,1)-(S(M,2)-INT(S(M,2)))
45773 S(M,6)=S(M,6)/(N9-INT(S(M,2)))
45774 S(M,7)=S(M,9)-INT(S(M,9))+S(M,1)-(S(M,2)-INT(S(M,2)))
45775 S(M,7)=S(M,7)/(N9-INT(S(M,2)))
45780 REM:UPDATE SLOPE ACCEPTANCE LIMITS. START WITH TEST OF MIN SLOPE
45790 IF S(M,6)>S(M,3) THEN 45820
45800 REM:MIN ACCEPTABLE SLOPE OK AS IS
45810 GO TO 45840
45820 REM:UPDATE MIN ACCEPTABLE SLOPE
45830 S(M,3)=S(M,6)
45840 REM:NOW TEST MAX SLOPE
45850 IF S(M,7)<S(M,4) THEN 45880
45860 REM:MAX ACCEPTABLE SLOPE O.K. AS IS
45870 GO TO 45900
45880 REM:UPDATE MAX ACCEPTABLE SLOPE
45890 S(M,4)=S(M,7)
45900 NEXT M
45901 M=M-1
45930 RETURN
49000 REM:LIST ATMOSPHERIC PARAMETERS AT MANDATORY PRES LEVELS Y(M)
49001 PRINT @41:
49002 PRINT @41:
49003 PRINT @41:" *,"MANDATORY LEVELS"
49004 PRINT @41:
49005 PRINT @41:"ALT(FT) ALT(M) PR(MB) T(DEG-C) RH(%) N-UNITS *;
49006 PRINT @41:" M-UNITS G/M3 D-PT-DEF"
49007 Z$="-----"
49008 PRINT @41:Z$;Z$;"-----"
49010 DIM Y(7)
49020 RESTORE 49040
49030 READ @34:Y,M,T9
49040 DATA 1000,850,700,500,400,300,250,0,1
49050 REM:FETCH SURF PRES FROM P ARRAY
49060 V8=10000*(P(2,P(2,400))-INT(P(2,P(2,400))))
49070 REM:FETCH TIME-TAG D9 FROM P ARRAY USING PR V8
49080 GOSUB 49370

```

Figure F-4. Listing for Fourth File of Mini Refraction  
Sonde Program, 8 June 1978 (Page 8 of 10)



```

49090 REM:USE TAG D9 IN (P(1,N)+2) TO FIND N & INTERP FRACTION NO
49095 IF D9=1 THEN 49355
49100 GOSUB 49510
49110 REM:USE N & NO TO GET ALT W9 FROM F(2,N)
49120 W9=INT(F(2,N))
49122 IF M>0 THEN 49130
49124 W9=INT(F(2,F(2,400)))/100
49126 GO TO 49150
49130 Z9=INT(F(2,N-1))
49140 W9=0.01*(W9+NO*(Z9-W9))
49145 IF T9=>W9 THEN 49355
49150 REM:USE N & NO TO GET N-UNITS W8 FROM INT(F(3,N))
49160 W8=INT(F(3,N))/1000000
49170 Z9=INT(F(3,N-1))/1000000
49180 W8=1000*(W8+NO*(Z9-W8))
49190 REM:FETCH TEMP D8 FOR TAG D9
49195 D9=D9-2
49200 GOSUB 7000
49205 D9=D9+2
49210 REM:USE N & NO TO GET %RH, W1
49220 W1=F(3,N)-INT(F(3,N))
49230 Z9=F(3,N-1)-INT(F(3,N-1))
49240 W1=1000*(W1+NO*(Z9-W1))
49250 REM:CALC ABS HUM W2
49252 V6=D8
49254 GOSUB 15000
49256 W2=596*0.01*W1*V5/1013.25*373.16/(D8+273.16)
49258 REM:CALC DEW-PT-DEF W3
49260 GOSUB 21455
49270 PRINT @41: USING 45320:W9,0.3048*W9,V8,D8,W1,W8,W8+0.048*W9,W2,W3
49275 T9=W9
49280 IF M>0 THEN 49320
49290 REM:SURF PR DONE. OMIT 1000 MB IF SURF PR <=1000
49300 IF V8>1000 THEN 49320
49310 M=M+1
49320 M=M+1
49330 IF M=8 THEN 49355
49340 V8=Y(M)
49350 GO TO 49070
49355 PRINT *END OF PROCESSING*
49357 REM: THIS FILE ALTERED FOR CONT PRES SENSOR; PK-MCW-780314
49360 END
49370 REM:FETCH TAG D9 FOR PR V8
49380 D9=P(2,400)
49390 Z8=10000*(F(2,D9)-INT(F(2,D9)))
49400 Z9=10000*(F(2,D9-1)-INT(F(2,D9-1)))
49410 IF V8<Z9 THEN 49480
49420 IF V8<=Z8 THEN 49460
49430 LIST 49420
49440 PRINT *PR V8 TOO GREAT FOR TABLE F(2, )*
49450 STOP
49460 F9=(Z9-Z8)*(INT(F(1,D9-1)+1)-INT(F(1,D9)+1))+0.5
49465 D9=INT(F(1,D9)+1)+INT((V8-Z8)/F9)

```

Figure F-4. Listing for Fourth File of Mini Refraction  
Sonde Program, 8 June 1978 (Page 9 of 10)



```

49470 GO TO 49500
49480 D9=D9-1
49485 IF D9=1 THEN 49500
49490 GO TO 49390
49500 RETURN
49510 REM:USE TAG D9 TO FIND INTERP BASE N & FRACTION NO FROM P(3, )
49520 N=P(3,400)
49530 Z8=INT(P(1,N))+2
49540 Z9=INT(P(1,N-1))+2
49550 IF D9<Z9 THEN 49620
49560 IF D9<=Z8 THEN 49600
49570 LIST 49560
49580 PRINT "TAG D9 > TABLE TAGS"
49590 STOP
49600 N0=(D9-Z8)/(Z9-Z8)
49610 GO TO 49640
49620 N=N-1
49630 GO TO 49530
49640 RETURN
50000 REM:DETERMIME SURF PRES
50010 PRINT "P(2, ";P(2,400);")= ";P(2,P(2,400))
50020 FOR N=1 TO P(2,400)
50030 U9=P(2,P(2,400))-INT(P(2,P(2,400)))
50040 U8=P(2,P(2,400)-N)-INT(P(2,P(2,400)-N))
50050 PRINT "P(2, ";P(2,400)-N;")= ";P(2,P(2,400)-N)
50060 IF U9-U8=>1.0E-3 THEN 50080
50070 NEXT N
50080 FOR U5=N TO 1 STEP -1
50090 U7=P(2,P(2,400)-U5)-INT(P(2,P(2,400)-U5))
50100 U6=P(2,P(2,400)-U5+1)-INT(P(2,P(2,400)-U5+1))
50110 IF U6-U7<=0 THEN 50130
50120 NEXT U5
50130 N=P(2,400)-U5
50140 PRINT "P(2, ";N;") HAS BEEN CHOSEN AS SURF PRES"
50150 PRINT "WANT TO CHANGE SURF PRES? ENTR 1(+) OR 2(-)";
50160 INPUT Z9
50170 GO TO Z9 OF 50190,50210
50180 GO TO 50150
50190 PRINT "CHOOSE SURF PRES FROM LIST OF P(2,N); ENTR N ";
50200 INPUT N
50210 P(1,400)=N
50220 P(2,400)=N
50230 P(3,400)=N
50240 PRINT @41:"SURF PRES= ";10000*(P(2,P(2,400))-INT(P(2,P(2,400))))
50250 GO TO 9590

```

Figure F-4. Listing for Fourth File of Mini Refraction  
Sonde Program, 8 June 1978 (Page 10 of 10)

