

AD-A062 414

POLYTECHNIC INST OF NEW YORK BROOKLYN DEPT OF ELECTR--ETC F/6 5/1
THE USE OF CONSENSUS IN ANALYTICAL SAFETY.(U)
FEB 77 M L SHOUMAN, S SINKAR

N00014-75-C-0858

NL

UNCLASSIFIED

POLY-EE77-305

| OF |

AD
A062414



END
DATE
FILMED
3-79
DDC

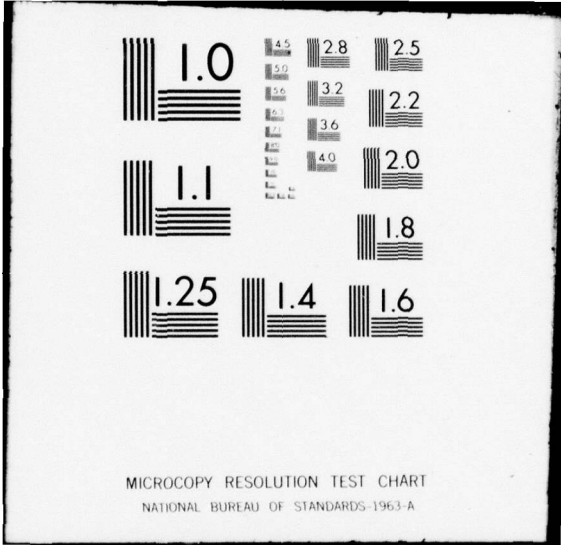

MICROCOPY RESOLUTION TEST CHART
NATIONAL BUREAU OF STANDARDS-1963-A

AD A062414

DDC FILE COPY

Polytechnic Institute of New York

2 *B.S.*

LEVEL #

11 FEBRUARY 1977

6 THE USE OF CONSENSUS IN ANALYTICAL SAFETY.

9 Technical rept.

10 by M. L. Shooman and S. Sinkar

14 POLY-EE-77-305
POLY-SMART-105

12 88p.

Program in SYSTEM AND DEVICE RELIABILITY

15 Contract No. N00014-75-C-0858
Office of Naval Research

DISTRIBUTION STATEMENT A
Approved for public release
Distribution Unlimited

DDC
RECEIVED
DEC 21 1978
RECEIVED
A

408 717 *Lee*
78 11 24 071

Unclassified

SECURITY CLASSIFICATION OF THIS PAGE (When Data Entered)

REPORT DOCUMENTATION PAGE		READ INSTRUCTIONS BEFORE COMPLETING FORM
1. REPORT NUMBER POLY EE-77-305	2. GOVT ACCESSION NO.	3. RECIPIENT'S CATALOG NUMBER
4. TITLE (and Subtitle) THE USE OF CONSENSUS IN ANALYTICAL SAFETY	5. TYPE OF REPORT & PERIOD COVERED Technical	
	6. PERFORMING ORG. REPORT NUMBER SMART 105	
7. AUTHOR(s) M. L. Shooman, and S. Sinkar	8. CONTRACT OR GRANT NUMBER(s) N00014-75-C-0858	
9. PERFORMING ORGANIZATION NAME AND ADDRESS Polytechnic Institute of New York 333 Jay Street Brooklyn, New York 11201	10. PROGRAM ELEMENT, PROJECT, TASK AREA & WORK UNIT NUMBERS Project NR 042-301	
11. CONTROLLING OFFICE NAME AND ADDRESS Chief Naval Research (Code 436) 800 N. Quincy Arlington, Virginia 22203	12. REPORT DATE February 1977	
	13. NUMBER OF PAGES 86	
14. MONITORING AGENCY NAME & ADDRESS (if different from Controlling Office) Office of Naval Research 207 W. 24th Street New York, New York 10011	15. SECURITY CLASS. (of this report) Unclassified	
	15a. DECLASSIFICATION/DOWNGRADING SCHEDULE	
16. DISTRIBUTION STATEMENT (of this Report) Reproduction in whole or in part is permitted for any purpose of the United States Government.		
17. DISTRIBUTION STATEMENT (of the abstract entered in Block 20, if different from Report)		
18. SUPPLEMENTARY NOTES		
19. KEY WORDS (Continue on reverse side if necessary and identify by block number) Failure Rate Data, Safety Probabilities, Data Collection, Consensus, Delphi Method, Expert Opinion, Fault Tree Probabilities, Clustering		
20. ABSTRACT (Continue on reverse side if necessary and identify by block number) Sometimes hard, quotable data is not available for the purpose of reliability analysis. Some of the reasons for non-availability of data are: (a) Field data is improperly or not recorded at all. (b) Data is of a proprietary nature and cannot be released. (c) Newness of concept or design prevents one from having a recorded history of field experience. (d) Failures occur with such a low frequency that many years (decades) are required to obtain significant failure data.		

REF	White Section	<input checked="" type="checkbox"/>
ENC	Buff Section	<input type="checkbox"/>
UNCLASSIFIED		<input type="checkbox"/>
JUSTIFIED		
<i>Att. on file</i>		
DISTRIBUTION AVAILABILITY CODES		
Dist.	AVAIL.	SPECIAL
A		

DD FORM 1 JAN 73 1473

EDITION OF 1 NOV 65 IS OBSOLETE

Unclassified

SECURITY CLASSIFICATION OF THIS PAGE (When Data Entered)

78 11 24 071

ABSTRACT

Sometimes hard, quotable data is not available for the purpose of reliability analysis. Some of the reasons for non-availability of data are:

- (a) Field data is improperly or not recorded at all.
- (b) Data is of a proprietary nature and cannot be released.
- (c) Newness of concept or design prevents one from having a recorded history of field experience.
- (d) Failures occur with such a low frequency that many years (decades) are required to obtain significant failure data.

Initiation of new data collection programs are often not feasible, in terms of money as well as time. Specifically, under the above circumstances it is costly to set up a laboratory life test or carefully monitor equipment already deployed in the field. Furthermore, in the safety area it is unthinkable to set up laboratory tests that expose humans to additional hazards.

As an aid in providing initial approximate numerical values where no data exists, the consensus approach is recommended. The consensus approach is really just an averaging of intelligent guesses by experts based on experience and partial data. In fact, sometimes actual proprietary data is available, and can only be furnished if it is reported as an "expert guess."

In this paper we will discuss analytical consenses, meaning a systematic approach involving careful descriptions of the assumptions about the experts and the resulting choice of statistical approach used in analyzing their opinions. This technique is different from, but has some of the same flavor as the technique used for estimation of prior densities in Bayesian Analysis and the Delphi Technique for forecasting.

In the consensus approach we ask a panel of experts to give their estimates (guesses) for the basic probabilities or failure rates for a well described system. The correctness of the results depends upon the knowledge and unbiasedness of the experts and the size of the sample (panel). The results based on the first round of the estimation can be fed back to the experts with the request that they provide revised estimates. If no names are used in the distributed results, some experts who are unsure of themselves and have guessed very high or very low may tend to revise their guesses closer to the mean of the group. If names are released, and one of the experts is well known and respected in the field, his opinions may dominate the second round.

To control the accuracy of the end results, the experts may be asked to rate their expertise on a suitable scale depending upon whether the guess is backed up by hard data, partial data, data on similar products, etc.

The expert may be requested to give a point estimate, a range estimate (minimum and maximum) or a three-point estimate (minimum, maximum and mean).

The estimates of the experts are then combined using a choice of techniques:

- (1) Maximum Likelihood Estimation (MLE)
- (2) An Unbiased Linear Combination (ULC)
- (3) A Linear Unbiased Minimum Variance (LUMV) estimator
- (4) Preanalysis of the data to determine if clustering is present (e. g., separate groups of optimists and pessimists) and segregation of the data into homogeneous groups. Subsequently, one of the above estimation techniques is applied to each group separately,

All these techniques result in relatively simple formulae which are presented along with the mathematical development in Appendix B.

These techniques have been applied to the shock hazard problem in power lawn mowers. This study was conducted in conjunction with the Consumer Product Safety Commission's (CPSC) Safety Standard Study Committee chaired by Consumers Union. This Committee participated in the formulation of safety standards presently being considered by the CPSC. The results of an analysis of the relative safety against shock hazards for two lawn mower designs is included. The basic event probabilities were generated by consensus analysis of about 10 expert opinions, and combined using fault tree analysis to yield equipment safety.

1.0 Introduction

1.1 Objectives: The purpose of this report is threefold: (a) to illustrate how the well-known analytical techniques of fault tree analysis can be used to study system safety; (b) to document a study using fault tree techniques which was performed to quantitatively investigate the relative electric shock safety of two different electric power lawn mower designs; (c) to develop new statistical techniques for handling in a scientific fashion the "guesstimates" of a group of experts as to the necessary elemental probabilities in safety analyses (consensus methods).

1.2 Fault Trees: The principles of fault tree analysis have been well documented in the literature. (Ref. 1, 2, 3, 4) The major reason for constructing a fault tree is to provide an analytical tool (in this case a topological vehicle) about which to focus the safety analysis. The analysis begins by a single engineer or a group listing all the possible modes of failure in the system and tracing in a cause and effect manner their consequences. Those modes which can cause injury or fatality (and in some cases property damage) are retained for the safety analysis. Borrowing a term from reliability analysis, this procedure can be called failure modes and effects analysis, FMEA. The fault tree is then constructed as a diagram which has a tree top event, injury or fatality, and lower events which branch out to include the combinations of elementary events (branch tips) which result in the tree top event. Logical AND and OR symbols are used to connect the events (faults) in the fault tree, which derives its name from the "branch like" structure beneath the top event.

1.3 Lack of Data: Safety analysis shares the problem with reliability analysis that there is almost always a problem in obtaining sufficient data. The fundamental reason for the problem is that we are dealing with rare events (which we wish to cause to be rarer still) and there is, therefore, little available failure data. It is

very costly in terms of dollars and time to set up a laboratory life test or carefully monitor equipment already deployed in the field to accumulate such data. Invariably such data gathering deals with previous designs and must be extrapolated with care to apply it to new designs.

In the case of the field of reliability which is 25-30 years old, much data has been accumulated. Although a large portion of this data is questionable with regard to accuracy and applicability, there is at least a partial data base to build on. Whenever an elementary event is included in the reliability data base, this data can be used. Since a large number of elementary events are important to safety but not reliability analysis, and safety analysis is perhaps only 5-10 years old, a paucity of safety data exists. Also most of the existing reliability data has been accumulated to support DOD or NASA projects and was paid for by them (e. g., the Minuteman Missile Program, the Apollo Program). The only large, funded, safety projects which have developed such data are those involving nuclear safety. The work on atomic weapons is still deeply classified, and the Rasmussen Study (Ref. 5) of the Safety of Nuclear Power Reactors has only been published in the last year. *

* In view of the fact that lack of data was one of the major stumbling blocks in this analysis, the NRC (successor to the AEC which sponsored the Rasmussen Study) is now sponsoring a study to construct a nuclear power reactor failure rate data manual. Similarly, the difficult and costly job of documenting "field failures" of deployed nuclear power reactors is in its embryonic stages and is being actively pursued by the NRC.

1.4 The Consensus Approach: As an aid in providing initial approximate numbers where no data exists, the consensus approach is recommended. The consensus approach is really just an averaging of intelligent guesses and partial data by experts. In this report we will deal with analytical consensus, meaning a more careful description of the assumptions about the experts and the resulting choices of statistical approaches to the averaging of the data. This work is different from, but has some of the flavor of, the techniques for estimation of prior densities in Bayesian Analysis.

The basis of the entire approach is that the experts to be queried have access to implicit or explicit data. First of all, in some cases an expert will have actual data which because of valid or imagined proprietary reasons, he is reluctant to reveal. For example, is it in the best interests of company X to reveal that in the last ten years during which they made and sold 1,000,000 toasters per year, three people were electrocuted by inserting a fork into that toaster to retrieve a jammed piece of toast without pulling the plug. Certainly an engineer would have fewer reservations in performing his calculations in private and basing his estimate on the results. In the former case we can make our own computations to check the accuracy of his interpretation, and we know our result is backed up by hard data. In the latter case we have no less accurate a result; however, unless we ask our expert for not only his estimate, but some feeling for whether or not it is based on data, we cannot comment on how believable the estimate is. Let us suppose that expert Y at another toaster company can find no data in his company's legal files of any electrocution suits involving the 300,000 toasters per year his company sells. He might estimate one such occurrence and calculate an upper bound on the probability. Suppose a third engineer at company Z which makes power hand tools but no toasters is asked for his estimate. Suppose he is familiar with shock problems with his own

products and has just read a study by the Consumer Product Safety Commission about electrocution and appliance cords. He learns that most of the injuries are due to young children contacting a live surface with their mouth. Other causes are much smaller. Suppose he estimates that the fork-toaster event should be about as probable as one of the "other causes" and bases his estimate on this line of reasoning.

Based on a knowledge of the three experts' sources of information, we would give most weight to expert X, less to expert Y, and least to expert Z. Lacking any knowledge of their expertise or data sources, we would treat them equally. Section 4.0 and the Appendix of this report formalize some of these assumptions and their statistical consequences.

We now explore how to test a second estimate by a new expert who also works at company X. We will call our old expert X_1 and our new one X_2 . If we knew that X_1 and X_2 were using the same data and obtained the same results, very little new information has been added (except that we are now less inclined to check X_1 's math since X_2 has already done this). If we know that X_2 worked from a different source or used a different approach than X_1 , then we must include him as a fourth independent estimate.

In attempting to apply the consensus method, we may borrow from the related Delphi Method^(Ref. 6), often used to estimate future events, and subject our experts to feedback. By feedback we mean that a second round of guesses is solicited after the results of the first round have been distributed. If no names are used in the distributed results, some experts who are unsure of themselves and have guessed very high or low may tend to revise their guesses closer to the mean of the group; whereas individuals very sure of themselves would "stand pat". If names were published with the results, the senior or recognized expert might tend to shift the guesses closer to his estimate. It is not clear whether feedback does result in improved estimates.

When guesses are given, they can be either a single point or a range. Although only a point guess was used in the Lawn Mower Study which is discussed in Section 5, the authors recommend an interval guess (high and low values) should be used. This is discussed in detail in Section 4 and in the Appendix.

One must also be concerned with a uniform bias on the part of the experts, perhaps due to a mood or an influential report or study which many of them have read. The best example of this is the statistician's fable of the time many centuries ago when a statistician wished to estimate the height of the Emperor of China. He asked 1 million Chinese, and because of the large size of the sample, estimated his height as ten feet with an extremely small variance. Unfortunately, none of these Chinese had seen the Emperor and guessed he must be a super human being. In the sense of our problem, none of them were experts since none of them had ever seen the Emperor.

The authors must emphasize that the merit of the consensus method is based upon the existence of some factual quantitative knowledge about failures by the experts. If the experts know little more about quantitative values than, say, a random selection of the general public, then the results will be of no value.

2.0 High Level Fault Tree for a Power Lawn Mower

2.1 Purpose of the Study: A fault tree diagram has many uses. In this high level study it is used to insure that a certain proposed standard* does not omit any hazards (injury modes). Fault tree diagrams will also be used in Section 3.0 to insure that the proposed standard guards against as many of the injury causative events as possible. The object of the studies in Sections 2.0 and 3.0 is to develop

*Standard developed by the members of the Consumers Union Study Group for use in the development of a Consumers Product Safety Commission Safety Standard for Power Lawn Mowers.

the expression for the probability of hazard and to study qualitative and quantitative effects of various sections of the safety standard suggested by members of the study group.

2.2 Correlation of Study to Safety Standard: As previously stated, the fault tree analyses of this section and the following section were performed as an aid in the evolution and study of a safety standard for power lawn mowers. Consumers Union, under contract to the U.S. Consumer Product Safety Commission, called together a group of interested consumer and industry representatives to work on the development of a draft standard. The written documents, evolving drafts, testimony, etc., would be carefully considered when subsequently the Consumer Product Safety Commission established the government standard.

Professor Shooman volunteered his services and was chosen as a consumer member of this study group. Prior to receiving a copy of the first draft of the standard prepared by Consumers Union as a working document for the first round of meetings, he prepared, with the assistance of his graduate class in reliability analysis, the fault tree given in Fig. B1. Several days later when a draft copy of the standard arrived, a detailed comparison of the standard and the fault tree showed that except for minor differences in grouping, both documents dealt by and large with the same hazards. The authors view this result as a check on the completeness of the documents.

2.3 Fault Tree Analysis: A first level fault tree is depicted in Fig. B1. Various hazards $H_1, H_2, H_3, \dots, H_{11}$ are linked by OR gates such that the occurrence of any of the hazards H_1, H_2, \dots, H_{11} leads to the occurrence of the top event. Hazards H_1, H_2, \dots, H_{11} are as follows:

- H₁ : Flying objects
- H₂ : Noise (Hearing)
- H₃ : Fire (Gas or Electric)
- H₄ : Limbs Touch Blade
- H₅ : Electric Shock (Gas or Electric)
- H₆ : Burns
- H₇ : Explosion
- H₈ : Recoil Starter
- H₉ : Curious Children
- H₁₀ : Out of Control
- H₁₁ : Flying object.

Basically the hazards H₁ and H₁₁ are the same, i. e. , flying objects. The difference lies in their effects. H₁ is the hazard where flying objects cause injury to the operator, whereas H₁₁ is the hazard where flying objects cause injury to bystanders, i. e. , people other than the operator.

2.4 Probability Expression: The probability of injury P_I is our numerical risk index (or probability of safety, P_S = 1 - P_I) and is related to the hazards by a probability expression.

Using the fault tree diagram and the principles of combinatorial logic and probability^(Ref. 7) we can write an expression for the probability of injury P_I. The legend on Fig. B2 indicates that the OR logic symbol is union (i. e. , one or more events must occur before the output event can occur) and the AND symbol is intersection (i. e. , the output occurs only if all inputs occur). The symbol + is used in our equation for union (OR) and the symbol · for intersection (AND).

In Fig. B1, injury occurs if one or more of the 11 hazards occur; therefore, the expression consists of the union of the 11 hazards:

$$P_I = P(H_1 + H_2 + H_3 + \dots + H_{11}) \quad (1)$$

Lower level fault trees can be developed for each of the hazards H_1, H_2, \dots, H_{11} and, similarly, probability expressions can be developed for each of the hazards H_1, H_2, \dots, H_{11} . (cf. Section 3.0)

2.5 Use in Design and Standard Making: The fact that the fault tree can be used from the conceptual stages through completion of the design makes it particularly useful in studying the effectiveness of the proposed standard. A fault tree for the top event (injury) is drawn and the probability expression for the top event is developed. It is then numerically evaluated using the probabilities of each event (before implementation of the proposed standard). The general probability expression pinpoints the events having maximum impact on the probability of the top event, thus helping us to direct our efforts toward regulations which will reduce the probability of such events. Numerical values of the probabilities evaluated using reduced event probabilities (after implementation of the standard) will give us a quantitative basis for justifying the proposed standard.

3.0 Lower Level Fault Tree for Power Lawn Mower Electric Shock Hazard

3.1 Purpose of Study: As was previously mentioned, one purpose of this study is to develop an expression for the safety probability of electric shock hazard and to study the qualitative and/or quantitative effects on safety of various clauses in the proposed standard. Specifically, we wish to compare the shock hazard of grounded type lawn mowers with the doubly insulated type.

E_7 : The event live wire touches conductive part of the mower.
This could be due to improper or loose connection at any terminal on the lawn mower.

E_8 : The event insulation of lawn mower does not work.
This could be either due to manufacturing defect, environment, or prolonged and rough use. Moisture or chemical deposition may render conductivity to insulating surfaces or cause corrosion. Excessive heat or rough use may develop cracks in insulation making it thus ineffective.

3.3 Fault Tree Analysis-Doubly Insulated Type: A fault tree for electric shock hazard of a doubly insulated lawn mower is depicted in Fig. B3.

All the events (primed) have the same meaning as the corresponding events in the case of grounded type lawn mowers except the following event:

E'_6 : The event protecting insulation does not work.
This could be either due to a manufacturing defect, environment, or prolonged and rough use.

For readers not familiar with insulation terminology we include suggested definitions*:

Double Insulation: An insulation system comprised of both functional insulation and supplementary insulation, with the two insulations physically separated and so arranged that they are not simultaneously subjected to the same deteriorating influences (temperature, contaminants, etc.) to the same degree. (See Fig. B4.)

*These definitions are taken from working documents of the CU/CPSC study (Ref. 8)

3.2 Fault Tree Analysis - Grounded Type Lawn Mower: A fault tree for electric shock hazard of a grounded type of lawn mower is depicted in Fig. B2.

The various possible events are linked by standard OR and AND gates. The outputs of lower level gates are fed as inputs to the higher level gates, thus leading to the top event electric shock (e. g., hazard 5 in Fig. B1).

A further explanation of the various events is given below:

- E_g: The event that a person is grounded or has a low resistance while operating the lawn mower. (Low resistance is that resistance which is sufficiently small to cause an electric shock for the specified operating voltage.)
- E₀: The event that the wire-plug of the mower is in while the mower is being repaired or adjusted.
- E₁: The event that a person touches a "live" part of the lawn mower. The live part considered here is a part which is normally live when a mower is connected to the supply, and not a part that has become live due to a fault.
- E₂: The event that a person touches cut (E₃) or damaged (E₄) cord when the mower is connected to the supply.
- E₃: The event that the cord is cut due to some sharp object either while the mower is in operation or stored.
- E₄: The event insulation of the cord does not work. (Damage due to environment, prolonged and or abusive use, etc.)
- E₅: The event that a person touches the conductive part of the mower (includes handle, blade, etc.) when the mower is connected to the supply.
- E₆: The event grounding does not work.
 This event is comprised of one or more of the following:
 - i) consumer does not have a grounded outlet box,
 - ii) ground wire is either broken or disconnected at the grounding terminal,
 - iii) high impedance grounding circuit exists.

Protective Insulation: An independent insulation provided in addition to the functional insulation to ensure protection against electric shock in case of failure of the functional insulation. An enclosure of insulating material may form a part or the whole of the protective insulation.

3.4 Probability Expression - Exact: Before we derive a hazard probability expression, we will briefly discuss the expansion of the probability of a union.

Assuming that event Y is the union of two disjoint events $X_1 + X_2$, we obtain:

$$Y = X_1 + X_2$$

$$P(Y) = P(X_1 + X_2) = P(X_1) + P(X_2) \quad (2)$$

If we consider the case of two events X_1 and X_2 which are not disjoint, we obtain:

$$P(X_1 + X_2) = [P(Z_1) + P(Z_2)] + [P(Z_3) + P(Z_2)] - P(Z_2)$$

$$= P(X_1) + P(X_2) - P(X_1 \cdot X_2) \quad (3)$$

Thus when events X_1 and X_2 are not disjoint, we must subtract the probability of the intersection of X_1 and X_2 from the sum of the probabilities.

Similarly, we can show that if X_1 , X_2 , and X_3 are not disjoint then:

$$P(X_1 + X_2 + X_3) = P(X_1) + P(X_2) + P(X_3)$$

$$- P(X_1 \cdot X_2) - P(X_2 \cdot X_3)$$

$$- P(X_1 \cdot X_3) + P(X_1 \cdot X_2 \cdot X_3) \quad (4)$$

The general expression for the union of n events follows by analogy. *

From Fig. B2 we see that the top event H (electric shock) occurs when the event E_g and at least one of the events E_A , E_B , and E_C occur simultaneously. Hence,

$$P(H) = P\{E_g \cdot (E_A + E_B + E_C)\} \quad (5)$$

* M. Shooman, op. cit., Eq. 2.12.

Events E_g , E_A , E_B , and E_C are independent and therefore:

$$\begin{aligned}
 P(H) &= P(E_g) P(E_A + E_B + E_C) \\
 &= P(E_g) \{ P(E_A) + P(E_B) + P(E_C) - P(E_A \cdot E_B) \\
 &\quad - P(E_B \cdot E_C) - P(E_A \cdot E_C) + P(E_A \cdot E_B \cdot E_C) \} \\
 &= P(E_g) \{ P(E_A) + P(E_B) + P(E_C) - P(E_A)P(E_B) \\
 &\quad - P(E_B)P(E_C) - P(E_A)P(E_C) + P(E_A)P(E_B)P(E_C) \} \quad (6)
 \end{aligned}$$

Similarly, from Fig. B3 we derive an expression for probability $P(H')$ as:

$$\begin{aligned}
 P(H') &= P(E_g) \{ P(E'_A) + P(E'_B) + P(E'_C) - P(E'_A)P(E'_B) \\
 &\quad - P(E'_B)P(E'_C) - P(E'_A)P(E'_C) + P(E'_A)P(E'_B)P(E'_C) \} \quad (7)
 \end{aligned}$$

3.5 Approximate Probability Expressions: We know that the ultimate use of the above expressions is to estimate the numerical values of the probability of hazard occurrence so that the probabilities of hazards for two different types (e. g. , grounded type and doubly insulated type) can be compared on a quantitative basis. It is therefore necessary to expand this expression further into probabilities of the basic events E_g, E_1, \dots, E_8 . The use of the method of consensus to obtain these probabilities is discussed in Section 5.0. Substitution of these probabilities will give us numerical values for the probability of hazard.

We see that the above expression is complicated, and further expansion into the probabilities of the basic events will give rise to a very complex expression. It is therefore desirable to approximate the expressions, Eq. 6 and 7, without losing significant terms.

For a grounded type lawn mower, the probabilities of the events E_A , E_B , and E_C are small, and therefore, a product of the two or more such terms becomes negligibly small. Neglecting these product terms from Eq. 6, we get our first approximation as:

$$P(H) \approx P(E_g) [P(E_A) + P(E_B) + P(E_C)] \quad (8)$$

From Fig. B2, we see that the event E_A occurs only when event E_0 and event E_1 occur simultaneously. Event E_A therefore is the intersection of the two events E_0 and E_1 . Probability of the event E_A is thus given as:

$$P(E_A) = P(E_0 \cdot E_1)$$

and assuming that events E_0 and E_1 are independent:

$$P(E_A) = P(E_0)P(E_1) \quad (9)$$

Similarly, probabilities of events E_B and E_C can be expressed as follows:

$$\begin{aligned} P(E_B) &= P\{E_2 \cdot (E_3 + E_4)\} \\ &= P(E_2)P(E_3 + E_4) \\ &= P(E_2)\{P(E_3) + P(E_4) - P(E_3 \cdot E_4)\} \\ &= P(E_2)\{P(E_3) + P(E_4) - P(E_3)P(E_4)\} \end{aligned} \quad (10)$$

$$\begin{aligned} P(E_C) &= P[E_5 \cdot E_6 \cdot (E_7 + E_8)] \\ &= P(E_5)P(E_6)P(E_7 + E_8) \\ &= P(E_5)P(E_6)[P(E_7) + P(E_8) - P(E_7 \cdot E_8)] \\ &= P(E_5)P(E_6)[P(E_7) + P(E_8) - P(E_7)P(E_8)] \end{aligned} \quad (11)$$

Substituting the expressions for $P(E_A)$, $P(E_B)$, and $P(E_C)$ into Eq. 8, we get our first approximation as:

$$\begin{aligned} P(H) &= P(E_g)\{P(E_0)P(E_1) + P(E_2)[P(E_3) + P(E_4) - P(E_3)P(E_4)] \\ &\quad + P(E_5)P(E_6)[P(E_7) + P(E_8) - P(E_7)P(E_8)]\} \end{aligned} \quad (12)$$

Since all the probabilities of basic events are small, $P(E_1) < 1$, we can make further approximations. In the above expression we see that the product term $P(E_3)P(E_4)$ is very small compared to the sum term $[P(E_3)+P(E_4)]$, and the product term $P(E_7)P(E_8)$ is also very small compared to $[P(E_7)+P(E_8)]$. We can therefore omit these terms without the loss of much accuracy in the final value. The final approximation for $P(H)$, therefore, is:

$$P(H) \approx P(E_g) \left\{ P(E_0)P(E_1) + P(E_2)[P(E_3)+P(E_4)] + P(E_5)P(E_6)[P(E_7)+P(E_8)] \right\} \quad (13)$$

In the case of the doubly insulated type lawn mower, following similar arguments, we obtain as the final approximation for the probability of hazard $P(H')$:

$$P(H') \approx P(E'_g) \left\{ P(E'_0)P(E'_1) + P(E'_2)[P(E'_3)+P(E'_4)] + P(E'_5)P(E'_6)[P(E'_7)+P(E'_8)] \right\} \quad (14)$$

4.0 Consensus Approach to Estimation of Hazard Probabilities

4.1 Basis of Consensus: In our Lawn Mower Safety Studies, hard quotable data was not available; therefore, we adopted a consensus approach to the estimation of hazard probabilities. The reasons for non-availability of hard data in this case are:

- (a) Improper or non-recording of hard data: In our electric shock hazard study we needed frequency of shock injury, but we could not get such data as it is not recorded. The reasons for non-recording of such data are: Firstly there is no central agency which maintains records on lawn mower injuries.*

* The NEISS injury data collection system (Ref. 9) run by the U. S. Consumer Product Safety Commission collects injury data by maintaining a survey at statistically selected hospital emergency rooms. Little data exists on lawn mower electric shock which is a few years old. Cases of electrocution or minor shock discomfort may never pass through a hospital emergency room.

Secondly, for minor shocks people are unlikely to spend time in reporting the shock. Thirdly, in case of severe injuries, they might not report either due to emotional upset or based on counsel from the legal adviser who would be concerned how such a report might affect their compensation.

- (b) Proprietary Data: In some cases failure data is recorded by the manufacturer, but because of perceived or real competitive and legal pressures, he will not permit the data to be directly released and attributed to the firm. In many cases he would, however, report such data (perhaps in summary form) as an estimate.
- (c) Newness of Concept or Design: When some new product is introduced (by new product we mean the concept itself is new and not just an old product introduced by a new company), it takes several years before any significant real data is accumulated.

4.2 Knowledge of the Expert: In the consensus approach we ask a panel of experts to give their estimates (guesses) for the basic probabilities. The 'correctness' of the results depends upon the knowledge of the experts and the size of the sample (panel).

By knowledge of experts, we mean the experience and familiarity with the particular problem and not their general credentials. In our study (electric shock hazard) estimates from electrical, mechanical, and industrial engineers would show better results than those from bank tellers and secretaries. On the other hand, if we wish to study availability (or reliability) of electric typewriters, estimates from secretaries and clerks would be more valuable than those from electrical engineers.

Members of our panel were qualified engineers working in manufacturing, designing, management, or academic fields. In addition, many of the panel were also working members of the Consumers' Union Study Group for the development of a Safety Standard for Power Lawn Mowers. This working group was familiar with the reports published by CPSC, CU, NEISS, etc., on the available injury data concerning Power Lawn Mower Shock hazards, as well as similar problems with other electrical appliances. In our first estimate twelve experts participated, and seven of these submitted revised estimates after seeing a summary of the original results.

4.3 Different Types of Consensus: Clearly, there are several ways to implement the concepts of consensus using statistical estimation principles. Some statisticians have proposed using Bayesian Analysis techniques, and the Appendix of this report develops a set of techniques which are related to classical maximum likelihood theory. Although the details differ, the end numerical results should be similar.

When one asks an expert for a probabilistic estimate, he might request a point estimate, a range estimate (min and max), or a min, max, and average estimate. In Section 5 the panel of lawn mower experts were asked to give a point estimate. We then contemplated using either the mean, the median, or the maximum or minimum as our estimator, which is discussed in Section 5. Subsequent to this study, the authors concluded that a two or three point estimate was superior, and the estimator formulas given in the Appendix were generated.

In addition to the number of points guessed by each expert, we may wish to rate the experts (either a self-rating or a rating by those who analyze the data). If such ratings appear meaningful, we may wish to give greater weight to some experts.

In all cases of interest the random variable will be time to occurrence of some failure or unsafe condition. Experience in the reliability field has shown that either exponential or Weibull distributions are the most appropriate models. General formulas for any one and two parameter distributions, as well as specifically the exponential and Weibull models, are derived in Appendix A.

4.4 Analytical Approach to Consensus: We have already discussed in Section 1 the several approaches one may take to estimation of probabilities using consensus. Appendix A contains a mathematical development of each of these methods. We will summarize the results only in this section, and we refer the reader to Appendix A for details.

If we have a single expert, we could generate from one to three estimates depending on how he is instructed. If asked to give one best guess, only one data point would be obtained. However, if he were asked to guess the minimum and maximum, two data points would result. Similarly, if he is asked for a minimum, maximum, and mean, three data points result. We consider the two and three data point cases in Appendix A and discuss the single data point case in Section 5 (for n experts). If the underlying failure density is assumed exponential (constant hazard), then the single failure rate parameter, λ , and its variance is estimated using formulas A16-A19. Similar expressions for a Weibull density function (hazard = kt^m) are derived in Eqs. A21-A28. In this case we must estimate both the scale parameter k and the shape parameter m and their variances.

For the case of n independent experts, these expressions generalize (as intuition would predict) to Eqs. A29-A36. Note that the exponential case can be considered a special case of the Weibull, where $m = 0$, and $k \equiv \lambda$.

As was previously discussed, we may not wish to give all experts' guesses the same weighting. In this case a simple approach is to use the equations cited above for the single expert case and obtain a set of estimates for each expert. These can then be combined via the linear combination given in Eq. A37. If we wish the estimate to be unbiased, the weighting factors must sum to unity as in Eq. A38. If we wish to use experience and judgment to assign the relative weights to the various a_i 's, then the form given in Eq. A39 is more convenient. On the other hand, if we wish the variance of the estimator to be minimized, then the weighting coefficients, a_i 's, are inversely proportional to the variance of the individual guesses as shown in Eq. A40.

5.0 Results of the Lawn Mower Shock Hazard Study

5.1 Introduction: As discussed previously, while the mathematical basis of consensus estimation was being explored, in parallel the concepts were being applied in the Lawn Mower Safety Study. Because of circumstances, much of the application preceded the theoretical studies. Thus, in this section we deal with a single estimate from each of the experts and use the median of the distribution as our parameter estimator.

5.2 Consensus Estimates: Early in the discussions of the CU/CPSC Electric Shock Hazard Subcommittee, we decided that it would be a useful learning exercise to apply Fault Tree Analysis and Consensus Estimation to the quantitative analysis of lawn mower shock hazards. In addition, the group felt it would be of use in comparing the shock hazards due to grounded type and doubly insulated type electric lawn mowers.

Initially twelve experts participated in the estimation process. After receiving a summary of the first round of estimation, and a discussion of a

subcommittee meeting, the group was asked to send in revised estimates, and seven responded.

On the second round the experts were asked to estimate the probabilities associated with present lawn mowers, as well as how they would change if the proposed safety standard were implemented in the form envisioned at that time. Not all the respondents gave both estimates on the second round.

Although all the estimates were shown individually to the Committee, they were coded by number (only known to Mr. Sinkar, who did not participate as an expert), and thus personalities had little influence on the consensus process.

5.3 Numerical Probabilities: We received twelve responses from the experts for our first iteration. All the participants gave two sets of basic probabilities (cf. Figs. B2 and B3), one for the grounded type lawn mower and the other for the doubly insulated type. (See Appendix C, Tables C1, C2). All the estimates were without consideration of the CPSC mandatory standard.

We preferred the median method^{*} to the mean method because in the mean method one or two estimates of extremely high (or low) numerical value tend to shift the results; whereas in the median method it is the distribution that plays the important role. (See Tables C3, C4.) To illustrate this further, we cite an example from "Project DELPHI".^(Ref. 10)

The experiment was designed to apply expert opinion to estimate, from the viewpoint of a Soviet strategic planner who is devising an optimal attack on U. S. industry, the number of A-bombs required to reduce the munitions output by a prescribed amount.

* A further discussion of the relative merits of the mean and the median is given in Section 6.

The primary estimate (first iteration) received from seven respondents are as follows:

Respondent	1	2	3	4	5	6	7
Estimated Number	125	50	150	300	200	1000	5000

The mean of the above estimates is 975. We clearly see that the mean shifted by two high estimates, i. e., 1000 and 5000. The median of the above estimates is 200. We also see that four out of seven estimates lie in the small range of 100-300. Hence the median is a more representative estimate than the mean.

In our lawn mower study, after substituting the median probability of each of the basic events, from Tables C3 and C4 we get the following numerical values for the probabilities of the hazards:

$$P(H) = 0.554265625 \times 10^{-2}$$

$$P(H') = 0.2361775 \times 10^{-2}$$

We then fed back and discussed the summary of the results with the experts and requested the revised estimates. This time we requested two sets of estimates for each type of lawn mower. The first set consisted of the numerical probabilities without consideration of the mandatory standard and the second set with consideration of the mandatory standard.

This time we received seven estimates of probabilities with consideration of the mandatory standard and three estimates without consideration of the mandatory standard. (See Tables C5-C10.)

After substituting the medians for each of the basic probabilities, we get the following second round numerical values for the probabilities of the hazard.

Without safety mandate:

$$P(H) = 3.1875 \times 10^{-2}$$

$$P(H') = 0.805005 \times 10^{-2}$$

With safety mandate:

$$P(H) = 0.08064 \times 10^{-2}$$

$$P(H') = 0.08033296 \times 10^{-2}$$

5.4 Conclusions: Although we cannot draw general conclusions as to convergence or validity of consensus probabilities from one such an experiment, we can cite the following conclusions pertaining to this particular problem:

- (1) The Fault Tree representation gave better insight to the different faults and their effects on the hazard. It also helped in assuring that no important possible fault was left out.
- (2) The second round of the estimates gave a smaller range within which all the estimates lay, although we could not draw any conclusions about their distribution.
- (3) Without safety mandates the probability of shock hazard of the doubly insulated lawn mower is lower (25%) than the probability of the shock hazard of the grounded type lawn mower. After introduction of the safety mandates, the probabilities of the shock hazards of both the types is approximately the same.

The general opinion of the members of the sub-committee was that although the validity of the exact numerical values of the probabilities could be questionable, the analysis provided relative rankings which helped in establishing the safety mandates.

6.0 Preliminary Analyses of Raw Consensus Data

In reviewing an early version of this material, Mr. George Levenbach^(Ref. 11) called to the authors' attention the fact that there might be significant bias in consensus data, and it would be worthwhile to consider preanalysis of this data. For example, it might quite likely be that among our group of experts there would be a cluster of optimists and a cluster of pessimists, who fairly consistently estimated probabilities high or low depending upon this particular bias. Levenbach suggested that we apply some of the new statistical techniques of cluster analysis and spanning-tree analysis. (Ref. 12, 13)

Since many of the readers may be unfamiliar with this new body of statistical techniques, (as were the authors before Levenbach called it to their attention) a simplified heuristic technique is used in this paper to perform in essence the same type of analysis of bias. Additional approaches are discussed in Sections 6.2 and 6.3.

6.1 Geometric Approach: The heuristic approach assumed that there might be two homogeneous clusters (or only one). The highest and lowest estimates were located (in some cases an obvious outlier was dropped) and the geometric mean used as the dividing line. The upper group (pessimist) was separately plotted as was the lower group (optimist). If the resulting distributions appeared clustered, then the two cluster hypothesis was accepted, and the data analyzed separately. If not, then the hypothesis that no clustering is present is accepted, and the data is lumped for analysis.

In applying this geometric technique, we plotted a frequency distribution of the responses on semilog paper to accommodate the wide dynamic range of the probabilities. The probability values were plotted on the abscissa (the log scale) and the coded number (so we could trace the expert's identity) was plotted on the ordinate. See Figure B5 which is one of the twenty such figures which could be

drawn from the data in Tables C1 and C2. The reader will observe that the logarithmic scale has nicely clustered the data.

The use of the geometric mean as a dividing point is essentially the same as deciding to use the arithmetic mean of the logarithm of the values.

$$\text{Geometric Mean} = \text{GM} = (x_1 \cdot x_u)^{1/2} \quad (15)$$

$$\log(\text{GM}) = \frac{1}{2} (\log x_1 + \log x_u) \quad (16)$$

If the expert guess was above the GM, then we called him a pessimist, P, and if below, we called him an optimist, O. Tables C11 and C12 present the results for all the experts on the ten probabilities which were estimated for the grounded type model. The last column represents the number of times he was judged a pessimist divided by 10, which is his pessimist rating. Inspection of this column shows that all experts except number 5 were quite consistently either an optimist or a pessimist. Thus the data was considered to be clustered and a high median and a low median was computed in each case as given in Table C13.

6.2 Average Distance Method: In this method we classify estimates in the same cluster if they are sufficiently close to one another. The measure of relative closeness to be used will be clarified by an example. Consider the eight data points:

.0001, .00015, .0002, .05, 0.75, 0.8, 0.82, 0.9

If we plot these graphs and study the results, our visual perception would classify them in two clusters, i. e., cluster 1 (.0001, .00015, .0002) and cluster 2 (0.75, 0.8, 0.82, 0.9). We would include in cluster 2 points at 0.82 and 0.9 although they are 0.08 units apart. At the same time we would be hesitant to include the unclustered point .05 in cluster 1 although it is only .0498 units from the next smallest value. This is because the distance though small in absolute value, is much larger (over 900 times) than the distance between any other two points in

cluster 1. Thus unless the point at 0.05 is to be treated as a third cluster, it is better to lump it with cluster 2, where its distance from the rest of the group is only about three times the next largest spacing.

Since we wish to deal with ratios of values, we deal with logarithms of the values, thus we prepare a table showing logarithm and coded number for each expert in ascending order of log probability. The last column in the table represents the distance of the point from the next higher value. Tables C15 to C34 summarize the results for all the events (i. e., $E_g, \dots, E_8; E'_g, \dots, E'_8$) of the study. Obvious outliers were neglected from our computation. We then computed average distance between two points. When two (or more) experts guessed the same probability value (and hence its logarithm), we considered them as two (or more) values separated by zero distance for our computation purpose. We defined our separating distance equivalent to three times the average distance. That means if the distance between any two consecutive points is greater than three times the average distance, then the two points belong to two separate clusters, otherwise they belong to one cluster.

Tables C15 to C34 show that out of twenty events ($E_g, \dots, E_8; E'_g$), four events (E_3, E_7, E'_0 , and E'_1) give one cluster, two events (E_2 and E'_5) give three clusters, and the next fourteen events give two clusters.

It is interesting to see that the results of these fourteen (two cluster) events are the same as the Geometric Mean method except for four events. In the case of event E_0 expert 10 is classified as a pessimist rather than an optimist in the G. M. method; in case of event E_4 , expert 5 is classified as a pessimist as against optimist in the G. M. method; in case of event E_8 , expert 9 is classified as pessimist as against optimist in the G. M. method; and in case of event E_g , expert 9 is classified as optimist as against pessimist in the G. M. method.

There are some obvious advantages and disadvantages of this method over the heuristic (G. M. method). The heuristic method always gives two and only two clusters, but the average method may give one, two, three, or sometimes

more than three clusters. In our analysis we can only use up to three clusters. (One cluster would give a point estimate, two clusters would give maximum and minimum, and three clusters maximum, minimum, and most likely.) The second disadvantage is that there is no uniformity in the number of clusters (i. e., for some events (e. g., E_3) we get one cluster, for some (e. g., E_1) we get three clusters). In our analysis we require to combine all the probabilities (E_g, \dots, E_8) to compute the probability of the top event (i. e., electric shock). Under such a condition there is no simple way of combining these events. One way to overcome this difficulty is to divide the guesses at the points between which the distance is maximum. This procedure will give two clusters except when the maximum distance is identical for more than one pair of points.

The major advantage of the average distance method is that the decisions on grouping are based on the relative distance between points, rather than the geometric mid-point between the extremes.

6.3 Correlation Clustering: Another clustering technique can be used which allows us to control the number of clusters and also utilize information on all the inter-point distances, not just the adjacent distances. This is based on an adaption of the method of Fortier and Solomon^(Ref. 14). We will not completely describe this method but will sketch its features and application to our consensus estimation method. An outline of the method follows:

- (1) One uses the correlation coefficient ρ as a measure of the distance between two variables,
- (2) The B function ("belongingness" function) is computed as the ratio of the average ρ for pairs belonging to the same cluster to the average ρ for pairs not belonging to the same cluster,

- (3) The B function is computed for all possible partitions, and the optimal cluster configuration is chosen as that one with the largest B.

The procedure becomes intractable rapidly as the number of points and the corresponding possible partition combinations increase. In fact, Fortier and Solomon focus on sampling methods to provide a tractable approximate solution.

In our consensus method we can considerably restrict the problem in that we are only interested in really the best two clusters or best three clusters. If we view our set of expert guesses as n points plotted along the x axis, it is easy to see that there are only $n-1$ possible dividing lines (clusters). We can develop the equivalent formula for three clusters by the following procedure. Divide points 1 and 2 to form 2 clusters. Then there are $n-2$ ways of separating the remaining clusters. Now consider the first dividing line between points 2 and 3. Now there are $n-3$ ways of separating the remaining clusters.

In computing the number of clusters up to three, N_3 , the degenerate cases of only 1 and 2 clusters appear as the first two terms and the summation term includes all the partitioned 3 cluster cases.

$$N_3 = 1 + (n-1) + \sum_{i=2}^{n-2} (n-i) = \sum_{i=1}^{n-1} (n-i) \quad (X)$$

$$= \sum_{i=1}^{n-1} n - \sum_{i=1}^{n-1} i = n(n-1) - \frac{n(n-1)}{2} = \frac{n(n-1)}{2} \quad (Y)$$

Thus, even for 3 partitions the number of trials is about $n^2/2$. Since it is unlikely that n will be much larger than 20 or 30 at most, perhaps a thousand computational cases are required, which is certainly feasible. The reader is referred to Ref. (14) for further details of correlation clustering method.

References

1. J. B. Fussell, "Fault-Tree Analysis - Concepts and Techniques," Aerojet Nuclear Co., Idaho Falls, Id.
2. M. L. Shooman, "The Equivalence of Reliability Diagrams and Fault Tree Analysis," IEEE Transactions on Reliability, May 1970.
3. W. E. Veseley and R. E. Narum, "PREP and KITT: Computer Codes for the Automatic Evaluation of a Fault Tree, IN-1349, August 1970.
4. J. B. Fussell, "Computer Aided Fault Tree Construction for Electrical Systems," Conference on Reliability and Fault Tree Analysis, California, Sept. 3-4, 1974.
5. "Reactor Safety Study: An Assessment of Accident Risks in U. S. Commercial Nuclear Power Plants," U. S. Atomic Energy Commission, WASH-1400 (Draft), August 1974.
6. H. Sackman, Delphi Critique, Lexington Books, D. C. Heath and Co., Lexington, Ma., 1975.
7. M. L. Shooman, Probabilistic Reliability: An Engineering Approach, McGraw-Hill.
8. "CPSC Standard for Power Lawn Mowers, Electrical Requirements, Suggested Definitions," Feb. 27, 1975.
9. "NEISS News," Volume 5, No. 3, U. S. Consumer Product Safety Commission.
10. N. Dalkey and O. Helmer, "An Experimental Application of the Delphi Method to the Use of Experts," Management Science, pp. 458-467, April 1963.
11. G. Levenbach, private communication.
12. J. C. Gower, "A General Coefficient of Similarity and Some of Its Properties," Biometrics, 27, pp. 857-875, 1971.
13. C. T. Zahn, "Graph-Theoretical Methods for Detecting and Describing Gestalt Clusters," IEEE Transactions on Computers, 6-20, pp. 68-86, 1971.
14. J. J. Fortier and H. Solomon, "Clustering Procedures," p. 493 in Multivariate Analysis, P. R. Krishnaiah, Academic Press, New York, 1966.

15. J. E. Freund, "Mathematical Statistics," Prentice Hall, Inc., pp. 204-208, also Exercise 6.
16. M. L. Shooman, op. cit., p. 475.
17. Ibid., p. 481.
18. Ibid., pp. 472-483. (Note, early editions of this text contain a computational error which is corrected here.)
19. Ibid., Chapter 8.
20. M. Messinger and M. L. Shooman, "Use of Classical Statistics, Bayesian Statistics, and Life Models in Reliability Assessment," consulting report, Piccatinny Arsenal, Dover, N. J., Contract No. AROD-10, pp. 116, 117, June 1971.

APPENDIX A

A. 1 Introduction

The mathematical development which follows can be derived independently or can be related to order statistics (Ref. 15) where the sample size is 2 or 3. The assumption is that k experts independently supply minimum and maximum or minimum, maximum, and average estimates of the random variable time to failure. The joint distribution of the lower estimate and upper estimate (or the lower estimate and the range) is derived, based upon an assumed sampling density function chosen from engineering experience or prior data. The estimates of the k experts are then combined using a choice of techniques:

- (1) Maximum likelihood estimation (MLE) theory,
- (2) An unbiased linear combination (ULC) of the k estimates where the weighting coefficients may be chosen according to the confidence we place in each estimation,
- (3) Using a linear unbiased minimum variance (LUMV) estimator. In this case the expert who guesses the smallest range has the most influence.

The analyst is free to pursue whichever of these approaches he prefers. Lacking any detailed data about the relative experience, conservatism, biases, or psychological factors which might underlie the experts' guesses, the MLE approach would be preferred.

A. 2. Derivation of Joint Density for Two Guesses

Suppose that each of the k experts guesses a minimum and maximum value for the random variable, time to failure (occurrence). For the first expert our notation will be $t_{1\min}$ and $t_{1\max}$ and for the k 'th expert $t_{k\min}$ and $t_{k\max}$ for the random variables, and $x_{k\min}$ and $x_{k\max}$ for the numerical values of the guesses for the k 'th expert. The joint density function for the k 'th expert may

be derived as follows. Letting:

$$\begin{aligned}
 P(x_{kmin} \leq t_{kmin} < x_{kmin} + \Delta x_{min}; x_{kmax} \leq t_{kmax} < x_{kmax} + \Delta x_{max}) \\
 &= \text{The joint probability of the min and} \\
 &\quad \text{max estimates} \\
 &= \varphi(t_{kmin}, t_{kmax}) \Delta x_{min} \Delta x_{max} \quad (A1)
 \end{aligned}$$

If we let $f(t_k)$ be the sampling density function and if both the minimum and maximum estimates are independent, then since there are two guesses (chances) that t_{kmin} will fall in the min interval, and given this occurrence only one chance that t_{kmax} will fall in the max interval we obtain:

$$\varphi(t_{kmin}, t_{kmax}) \Delta x_{min} \Delta x_{max} = 2f(t_{kmin}) \Delta x_{min} f(t_{kmax}) \Delta x_{max} \quad (A2)$$

and finally:

$$\varphi(t_{kmin}, t_{kmax}) = 2f(t_{kmin})f(t_{kmax}) \quad (A3)$$

For notational convenience we call $t_{kmin} = t_{k1}$ and $t_{kmax} = t_{k2}$

Thus:

$$\varphi(t_{k1}, t_{k2}) = 2f(t_{k1})f(t_{k2}) \quad (A4)$$

A. 3. Derivation of the Joint Density Function for Three Guesses

We can derive the joint density function for three guesses in a similar manner. We let t_{kmin} , t_{kave} , and t_{kmax} be denoted by t_{k1} , t_{k2} , and t_{k3} respectively and we again assume independence. There are three ways the first interval can be filled, then given it is filled two ways of filling the second, and given that the first and second are filled one way of filling the third. Thus:

$$\begin{aligned}
 \varphi(t_{k1}, t_{k2}, t_{k3}) &= [3f(t_{k1})] \times [2f(t_{k2})] \times [f(t_{k3})] \\
 &= 6f(t_{k1})f(t_{k2})f(t_{k3}) \quad (A5)
 \end{aligned}$$

A. 4. Estimation of Density Function Parameters for One Expert

We assume that the density function depends on either one parameter θ , or two parameters θ_1 and θ_2 , i. e., $f(\theta_1)$ or $f(\theta_1, \theta_2)$. Using maximum likelihood theory for a single parameter density function, we obtain the likelihood function from the joint density Eq. A4.

$$L(t_{k1}, t_{k2}, \theta_1) = 2f(t_{k1})f(t_{k2}) \quad (A6)$$

The MLE estimate for θ_1 is found by setting:

$$\frac{\partial L}{\partial \theta_1} = 0$$

As a convenience in the differentiation one generally takes the \ln of L first. This is valid since the maximum of $\ln L$ and L occur at the same point due to the monolithicity of the \ln function. The labor saved in dealing with logarithms is due to the conversion of a product form into a sum form, which is easier to differentiate.

$$\ln L = \mathcal{L}$$

$$\therefore \frac{\partial \mathcal{L}}{\partial \theta_1} = 0 \quad (A7)$$

$$\mathcal{L} = \ln 2 + \ln f(t_{k1}) + \ln f(t_{k2})$$

$$\frac{\partial \mathcal{L}}{\partial \theta_1} = \frac{\partial \ln f(t_{k1})}{\partial \theta_1} + \frac{\partial \ln f(t_{k2})}{\partial \theta_1} \quad (A8)$$

Similarly, for three estimates we use Eq. A5 and obtain:

$$\frac{\partial \mathcal{L}}{\partial \theta_1} = \frac{\partial \ln f(t_{k1})}{\partial \theta_1} + \frac{\partial \ln f(t_{k2})}{\partial \theta_1} + \frac{\partial \ln f(t_{k3})}{\partial \theta_1} = 0 \quad (A9)$$

In the case of two parameters we obtain (analogous to Eqs. A8 and A9):

$$\frac{\partial \mathcal{L}}{\partial \theta_1} = \frac{\partial \ln f(t_{k1})}{\partial \theta_1} + \frac{\partial \ln f(t_{k2})}{\partial \theta_1} = 0 \quad (\text{A10})$$

$$\frac{\partial \mathcal{L}}{\partial \theta_2} = \frac{\partial \ln f(t_{k1})}{\partial \theta_2} + \frac{\partial \ln f(t_{k2})}{\partial \theta_2} = 0 \quad (\text{A11})$$

and for three estimates and two parameters we obtain:

$$\frac{\partial \mathcal{L}}{\partial \theta_1} = \frac{\partial \ln f(t_{k1})}{\partial \theta_1} + \frac{\partial \ln f(t_{k2})}{\partial \theta_1} + \frac{\partial \ln f(t_{k3})}{\partial \theta_1} = 0 \quad (\text{A12})$$

$$\frac{\partial \mathcal{L}}{\partial \theta_2} = \frac{\partial \ln f(t_{k1})}{\partial \theta_2} + \frac{\partial \ln f(t_{k2})}{\partial \theta_2} + \frac{\partial \ln f(t_{k3})}{\partial \theta_2} = 0 \quad (\text{A13})$$

Of course in the case of Eqs. A10, A11 and A12, A13 we must solve the two resultant equations simultaneously for θ_1 and θ_2 . Since these equations are often nonlinear and transcendental, a numerical solution is often required. Further discussion of numerical solutions appears in the references. (Ref. 16) We can also estimate the variance of our estimate of $\hat{\theta}$ (note the "hat" notation above θ means an estimate of θ) by using the large sample limiting form. (Ref. 17) The computation includes taking the second derivative of the ln of the likelihood function and substituting in the expression:

$$\text{Var } \hat{\theta} \approx \frac{1}{-\frac{\partial^2 \mathcal{L}}{\partial \theta^2}} \quad (\text{A14})$$

A. 5 Estimators of Exponential Density Function Parameters for One Expert

We now assume that experience, engineering assumption, or similarity between the event in question and other known data lead the analyst to conclude that the hazard function for the data is constant, i. e., the density function is exponential:

$$f(\theta) = f(\lambda) = \lambda e^{-\lambda t} \quad (\text{A15})$$

Substitution in Eqs. A8 and A14 as well as differentiation and simplification and subsequent substitution of $\hat{\lambda}$ for λ in the variance expression yields:

$$\hat{\lambda} = \frac{t_1 + t_2}{2} \quad (\text{A16})$$

$$\text{var } \hat{\lambda} \approx \frac{\hat{\lambda}}{2} \quad (\text{A17})^*$$

Similarly for three estimates we obtain:

$$\hat{\lambda} = \frac{t_1 + t_2 + t_3}{3} \quad (\text{A18})$$

$$\text{var } \hat{\lambda} \approx \frac{\hat{\lambda}^2}{3} \quad (\text{A19})^*$$

The results for the exponential density, Eqs. A16-A19, are just what intuition would lead us to believe.

A. 6 Estimators of Weibull Density Function Parameters for One Expert

If we suspect that wearout is present or there are other good reasons to believe that the hazard function is not constant, then we can use the Weibull model. The Weibull hazard kt^m corresponds to the density function:

$$f(k, m) = kt^m e^{-\left(\frac{k}{m+1}\right)t^{m+1}} \quad (\text{A20})$$

In an analogous fashion to the work of the previous section^(Ref. 18) the likelihood equations for an expert and two estimates become:

* These are rough approximations as are Eqs. A23, A24, A27, A28 since the sample size is 2 or 3. However, in Section A. 7 the sample size is $2n$ or $3n$ and the approximation will be better.

$$\hat{k} = \frac{2(m+1)}{t_{k1}^{m+1} + t_{k2}^{m+1}} \quad (\text{A21})$$

$$\sum_{i=1}^2 \ln t_{ki} = \frac{2 \sum_{i=1}^2 t_{ki}^{m+1} \ln t_{ki}}{\sum_{i=1}^2 t_{ki}^{m+1}} - \frac{2}{m+1} \quad (\text{A22})$$

Simultaneous solution requires either a graphical solution or an iterative computer solution (Ref. 19). In order to compute the variance:

$$\text{Var } \hat{k} \approx \frac{\hat{k}^2}{2} \quad (\text{A23})$$

$$\text{Var } \hat{m} \approx \frac{1/k}{\frac{2}{(m+1)^3} \sum_{i=1}^2 t_{ki}^{m+1} - \frac{2}{(m+1)^2} \sum_{i=1}^2 t_{ki}^{m+1} \ln t_{ki} + \frac{1}{m+1} \sum_{i=1}^2 t_{ki}^{m+1} (\ln t_{ki})^2} \quad (\text{A24})$$

Similarly, for one expert and three estimates we obtain:

$$\hat{k} = \frac{3(m+1)}{\sum_{i=1}^3 t_{ki}^{m+1}} \quad (\text{A25})$$

$$\sum_{i=1}^3 \ln t_{ki} = \frac{\sum_{i=1}^3 t_{ki}^{m+1} \ln t_{ki}}{\sum_{i=1}^3 t_{ki}^{m+1}} - \frac{3}{m+1} \quad (A26)$$

$$\text{Var } \hat{k} \approx \frac{\hat{k}^2}{3} \quad (A27)$$

$$\text{Var } \hat{m} \approx \frac{1/k}{\frac{2}{(m+1)^3} \sum_{i=1}^3 t_{ki}^{m+1} - \frac{2}{(m+1)^2} \sum_{i=1}^3 t_{ki}^{m+1} \ln t_{ki} + \frac{1}{m+1} \sum_{i=1}^3 t_{ki}^{m+1} (\ln t_{ki})^2} \quad (A28)$$

A.7 Combining the Estimates of n Experts Using MLE Theory *

The likelihood function, Eq. A6, was constructed by assuming independence of the two (or three) estimates of a single expert. If we have n experts and assume independence, then the likelihood function L is simply the product of each expert's likelihood function, and the logarithms of the likelihood functions become additive. Thus the derivative of the sum is the sum of the derivatives. Thus, for n experts the equations corresponding to A. 21 through A. 24 become:

$$\hat{k} = \frac{2n(m+1)}{n \sum_{i=1}^2 \sum_{j=1}^3 t_{ij}^{m+1}} \quad (A29)$$

* Note that a conflict in notation exists between the number of experts, k, and one of the parameters appearing in the Weibull model, Eq. A20, which is also k. Therefore, the number of experts will be represented by n in the remainder of the text.

$$\sum_{i=1}^n \sum_{j=1}^2 \ln t_{ij} = \frac{2n \sum_{i=1}^n \sum_{j=1}^2 t_{ij}^{m+1} \ln t_{ij}}{\sum_{i=1}^n \sum_{j=1}^2 t_{ij}^{m+1}} - \frac{2n}{m+1} \quad (\text{A30})$$

$$\text{Var } \hat{k} \approx \frac{\hat{k}^2}{2n} \quad (\text{A31})$$

$$\text{Var } \hat{m} \approx \frac{1/n}{\frac{2}{(m+1)^3} \sum_{i=1}^n \sum_{j=1}^2 t_{ij}^{m+1} - \frac{2}{(m+1)^2} \sum_{i=1}^n \sum_{j=1}^2 t_{ij}^{m+1} \ln t_{ij} + \frac{1}{m+1} \sum_{i=1}^n \sum_{j=1}^2 t_{ij}^{m+1} (\ln t_{ij})^2} \quad (\text{A32})$$

Similarly, Equations A25 through A28 generalize to yield:

$$\hat{k} = \frac{3n(m+1)}{\sum_{i=1}^n \sum_{j=1}^3 t_{ij}^{m+1}} \quad (\text{A33})$$

$$\sum_{i=1}^n \sum_{j=1}^3 \ln t_{ij} = \frac{3n \sum_{i=1}^n \sum_{j=1}^3 t_{ij}^{m+1} \ln t_{ij}}{\sum_{i=1}^n \sum_{j=1}^3 t_{ij}^{m+1}} - \frac{3n}{m+1} \quad (\text{A34})$$

$$\text{Var } \hat{k} \approx \frac{\hat{k}^2}{3n} \quad (\text{A35})$$

$$\text{Var } \hat{m} \approx \frac{1/n}{\frac{2}{(m+1)^3} \sum_{i=1}^n \sum_{j=1}^3 t_{ij}^{m+1} - \frac{2}{(m+1)^2} \sum_{i=1}^n \sum_{j=1}^3 t_{ij} \ln t_{ij} + \frac{1}{m+1} \sum_{i=1}^n \sum_{j=1}^3 t_{ij}^{m+1} (\ln t_{ij})^2} \quad (\text{A36})$$

A. 8 Combining the Estimates of n Experts Using ULC Theory

Assume that we have an estimate $\hat{\theta}$ for each parameter and its variance, $\text{Var } \theta$, obtained by the methods of Sections A.4 to A.6. We wish to weight the estimates, $\hat{\theta}_1, \hat{\theta}_2, \hat{\theta}_3$, etc., since we respect some experts opinions more than others. Thus we let:

$\hat{\theta}_i$ = parameter estimate derived for expert No. i ($i = 1$ to n) and write the linear form:

$$\hat{\theta}_{\text{ULC}} = a_1 e_1 + a_2 e_2 + \dots + a_n \theta_n \quad (\text{A37})$$

Assuming that the θ 's are independent, have the same means, and requiring them to be unbiased, we obtain^(Ref. 20):

$$\sum_i^n a_i = 1 \quad (\text{A38})$$

We now assume that the a_i 's will be chosen so that they reflect the relative confidence the analyst has in each expert.

For convenience it is easier to assign a set of weights, b_i , such that each b lies between 1 and 10, where the larger the value of b_i , the greater the trust. Thus, Eq. A37 can be written as:

$$\hat{\theta}_{ULC} = \frac{b_1 \hat{\theta}_1 + b_2 \hat{\theta}_2 + \dots + b_n \hat{\theta}_n}{\sum_{i=1}^n b_i} \quad (A39)$$

A.9 Combining the Estimates of n Experts Using LUMV Theory

We proceed as in Section A.8 and obtain Eq. A30. We then further require that the variance be minimized. The variance equation is given by (Ref. 20):

$$\text{Var}(\hat{\theta}_{ULC}) = a_1^2 \sigma_1^2 + a_2^2 \sigma_2^2 + \dots + a_n^2 \sigma_n^2 \quad (A40)$$

To do this we must use Lagrange multipliers or substitute Eq. A38 into Eq. A40 before we differentiate and set equal to zero. Using Lagrange multipliers, computing $\frac{\partial \hat{\theta}}{\partial a_1}$, $\frac{\partial \hat{\theta}}{\partial a_2}$, ..., $\frac{\partial \hat{\theta}}{\partial a_n}$ and setting each partial derivative to zero we obtain a set of simultaneous equations. Solution of these equations yields:

$$a_n = \frac{\frac{1}{\text{Var}(\hat{\theta}_n)}}{\sum_{i=1}^n \frac{1}{\text{Var}(\hat{\theta}_i)}} \quad (A41)$$

APPENDIX B

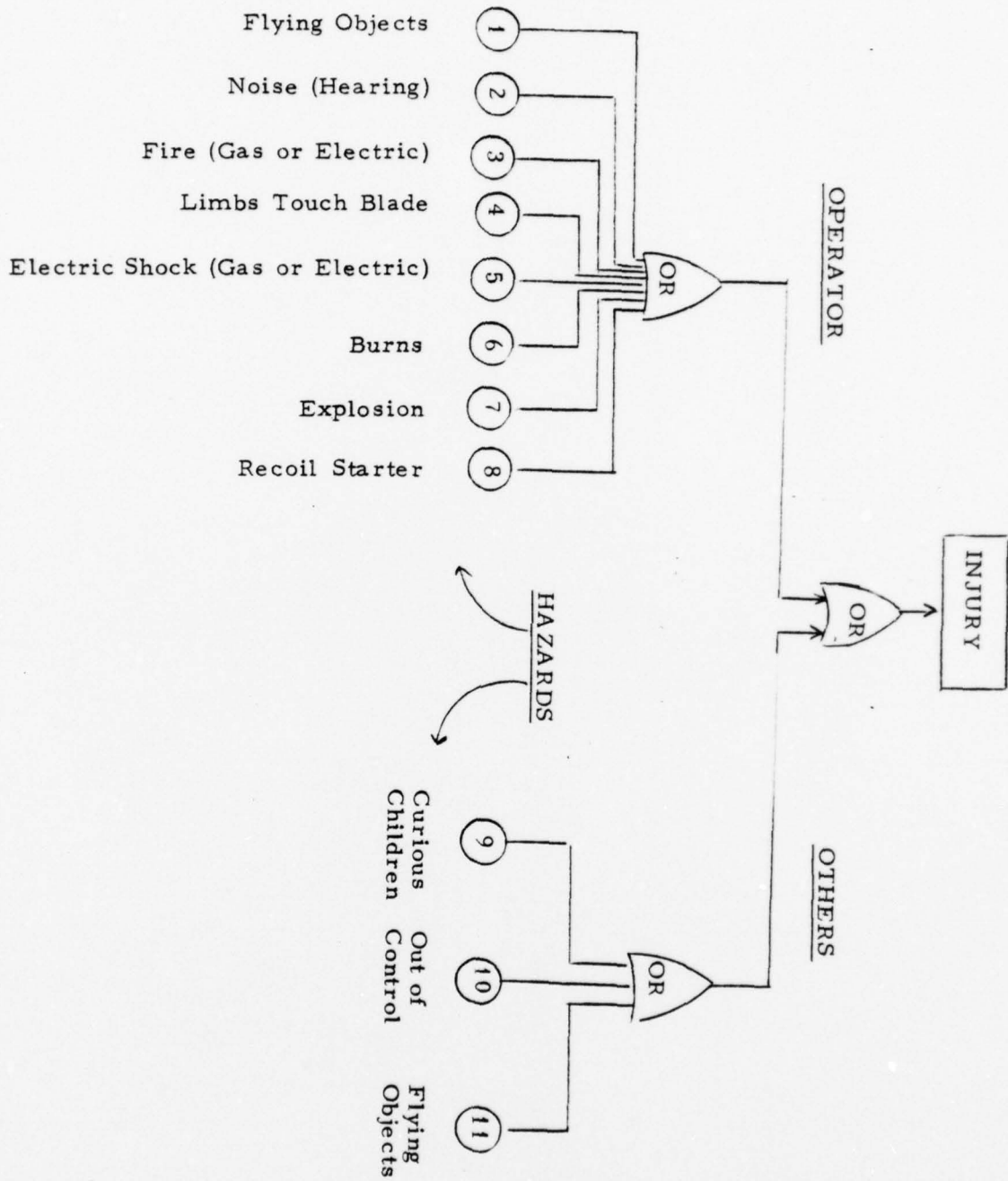

Figure B1. High Level Fault Tree for Lawn Mower.

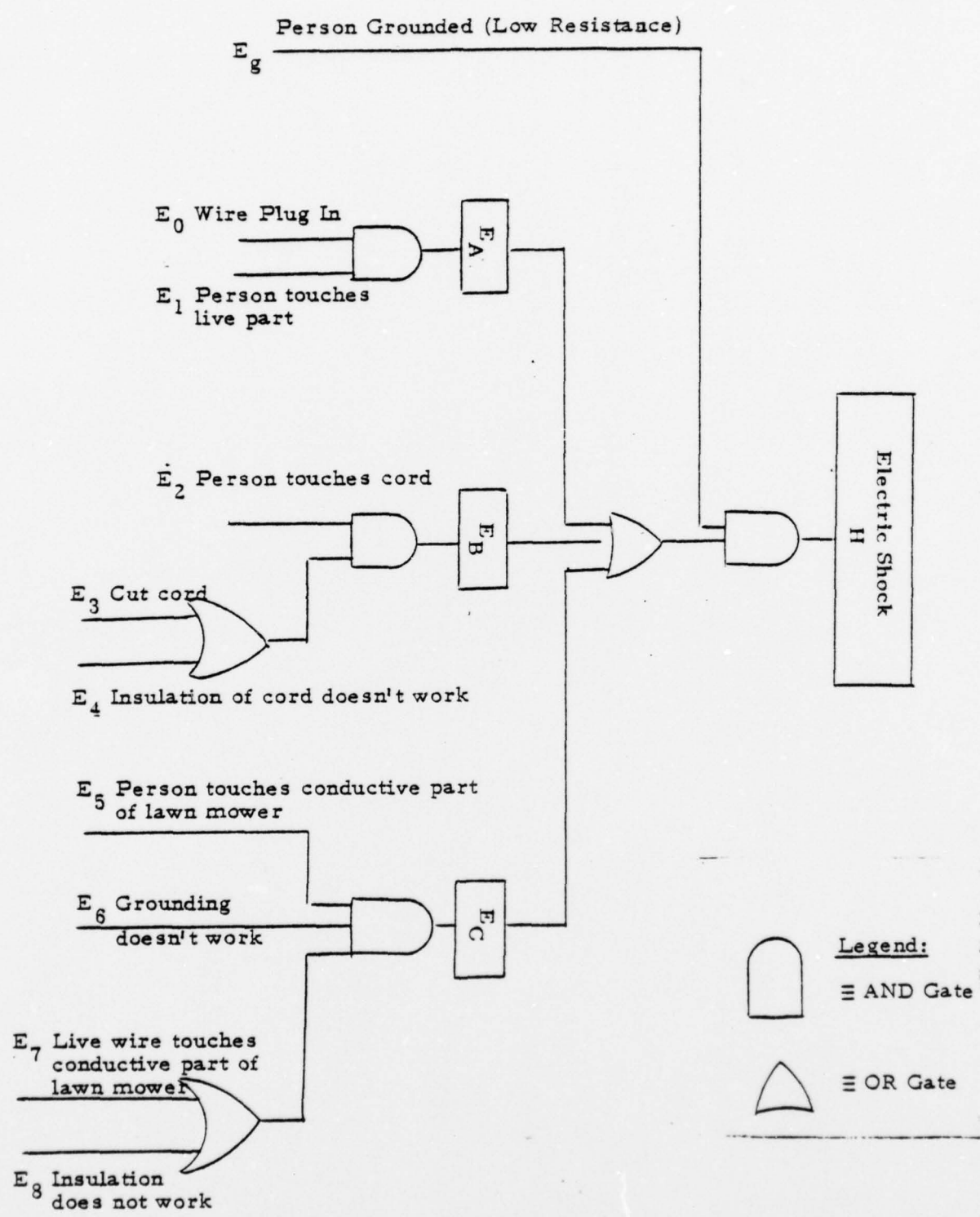

Figure B2. Shock Fault-Tree of a Grounded Type Lawn Mower.

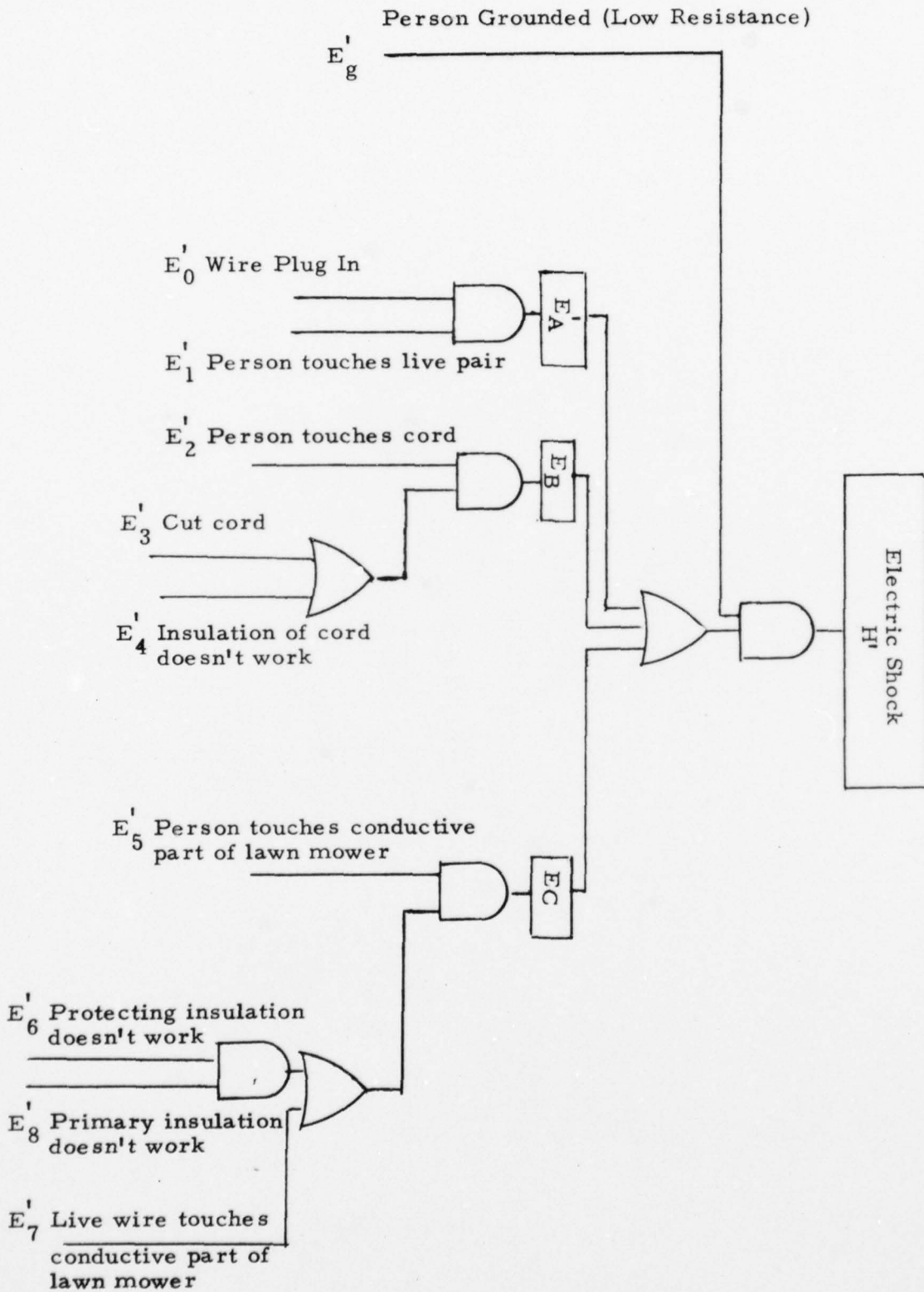
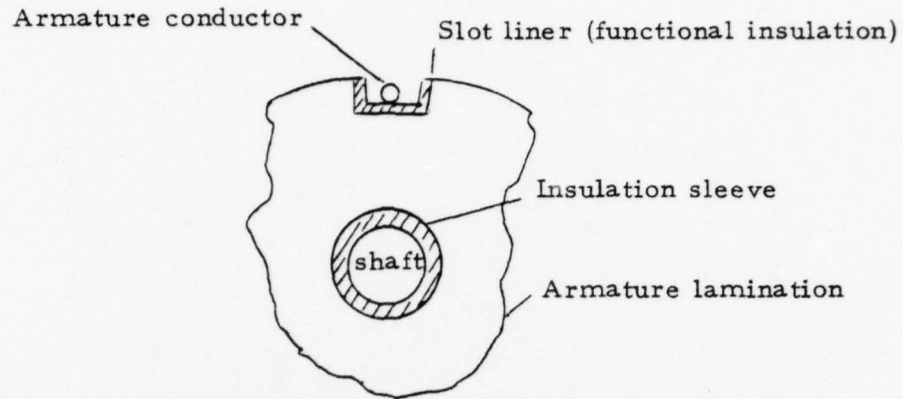
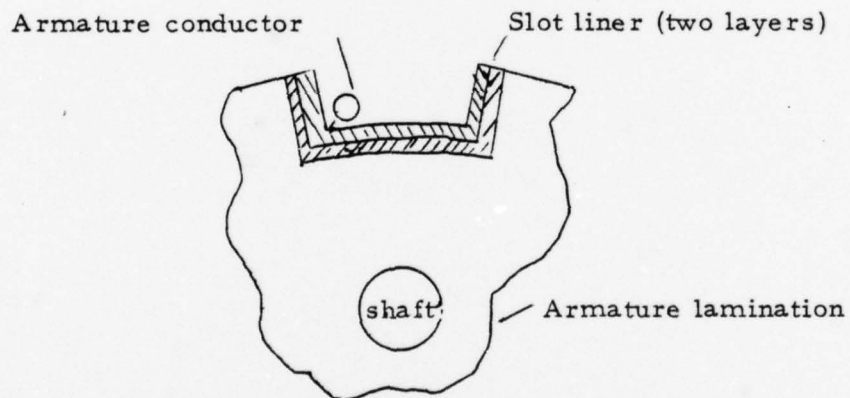

Figure B3. Shock Fault-Tree of a Double Insulated Lawn Mower.



a. Considered to constitute double insulation



b. Not considered to constitute double insulation

Figure B4. Illustrations Explaining Double Insulation*.

*Ibid.

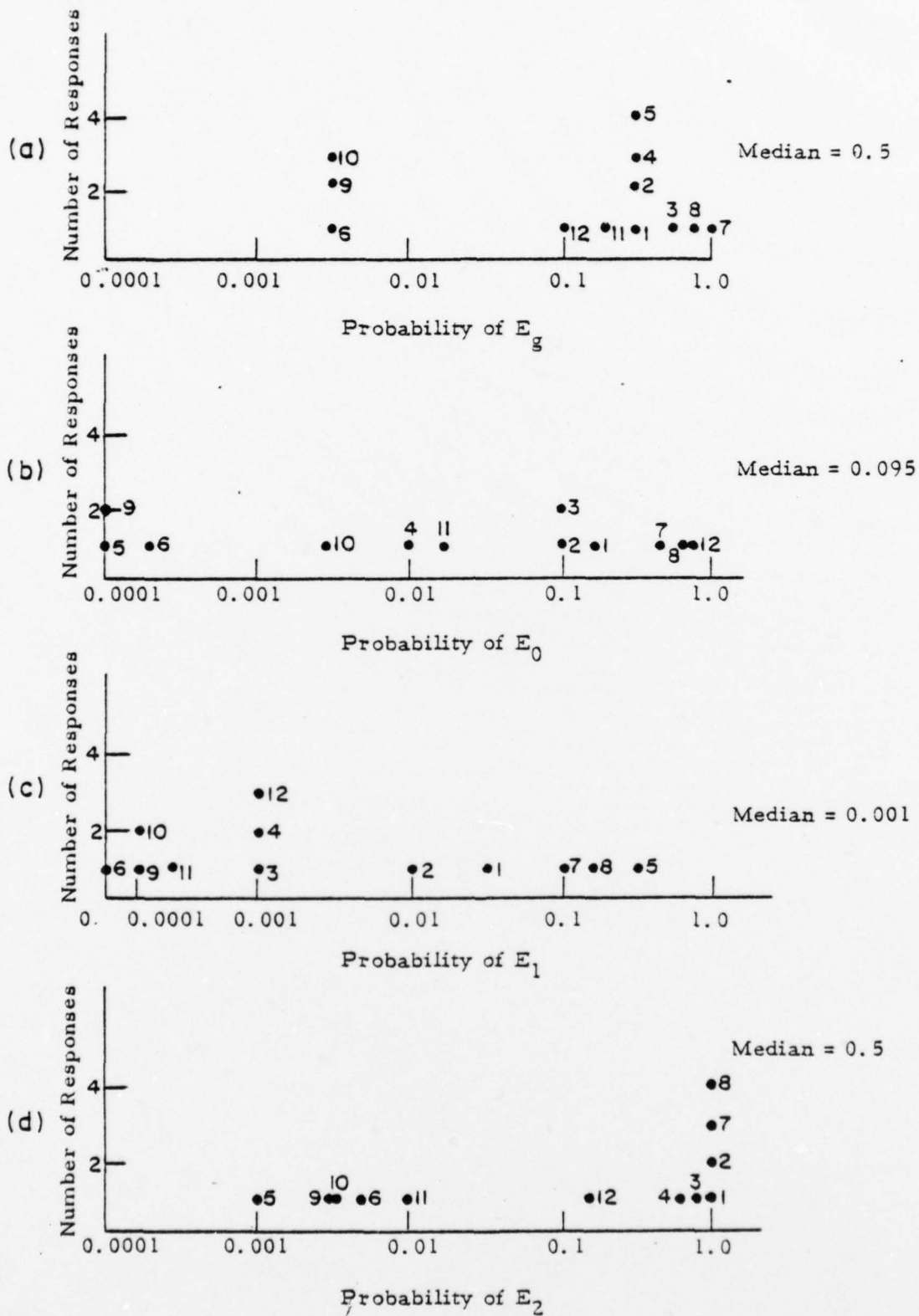

Figure B5. Log Plot of Consensus Data.

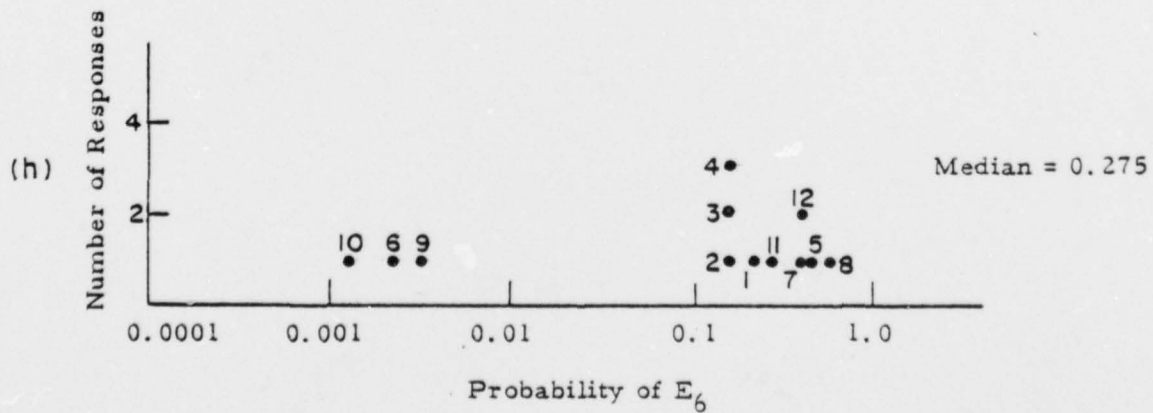
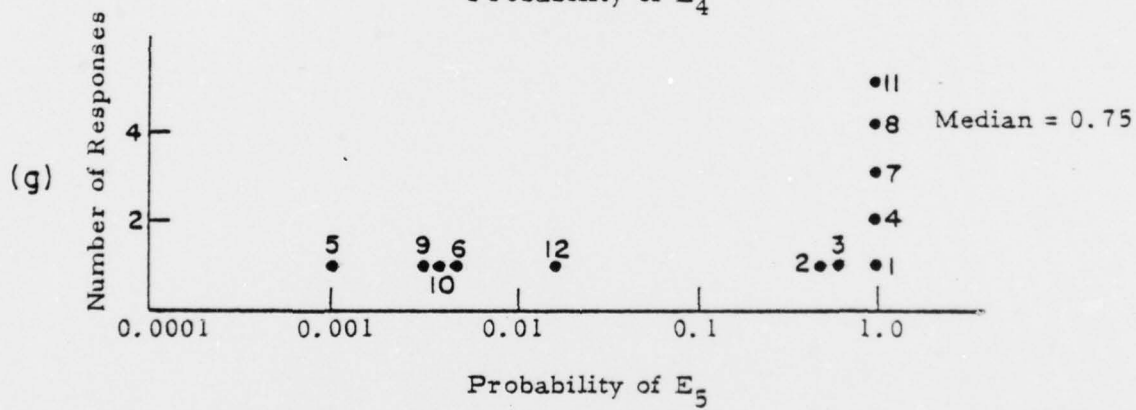
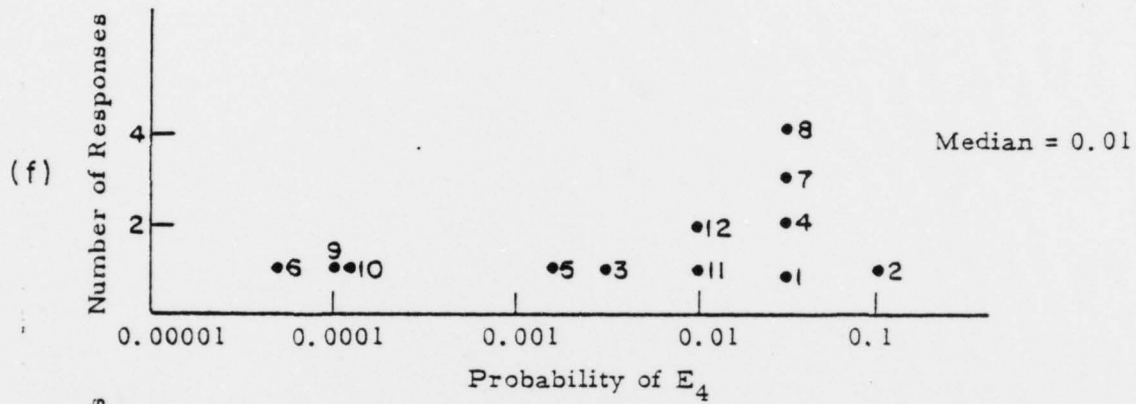
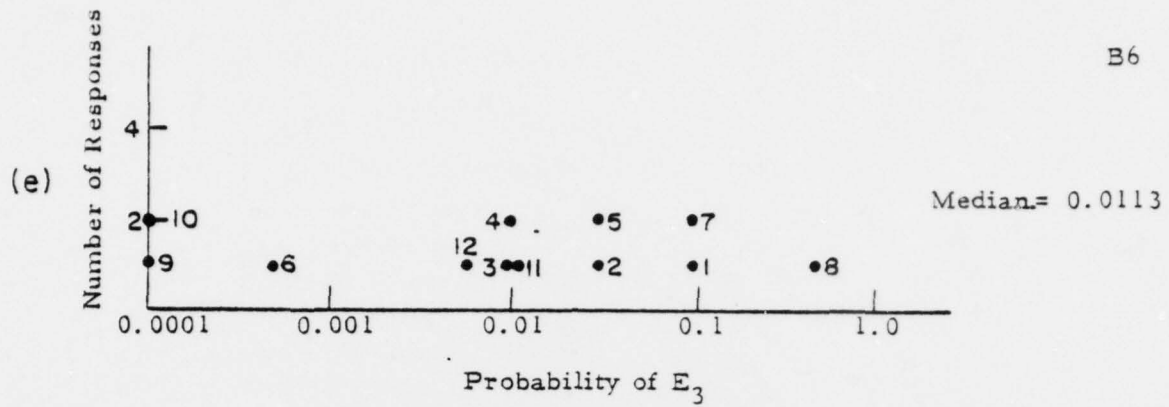

Figure B5. (continued)

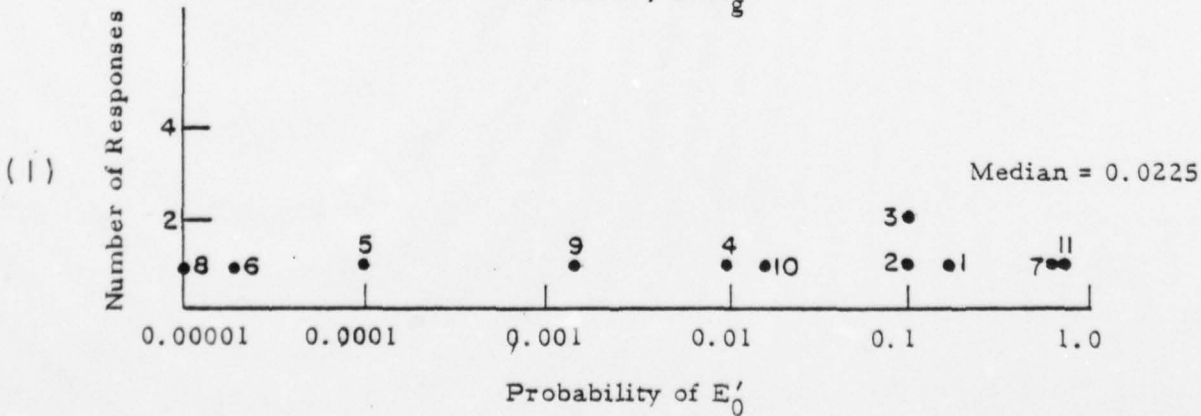
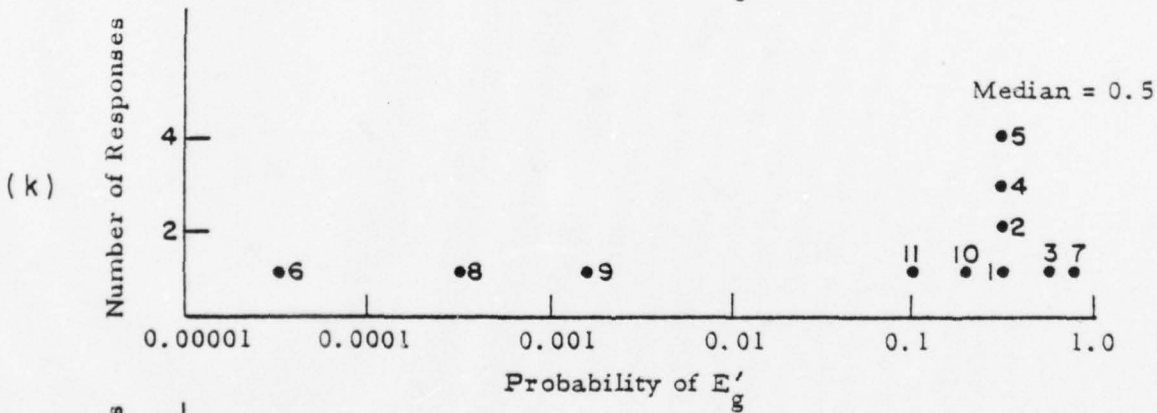
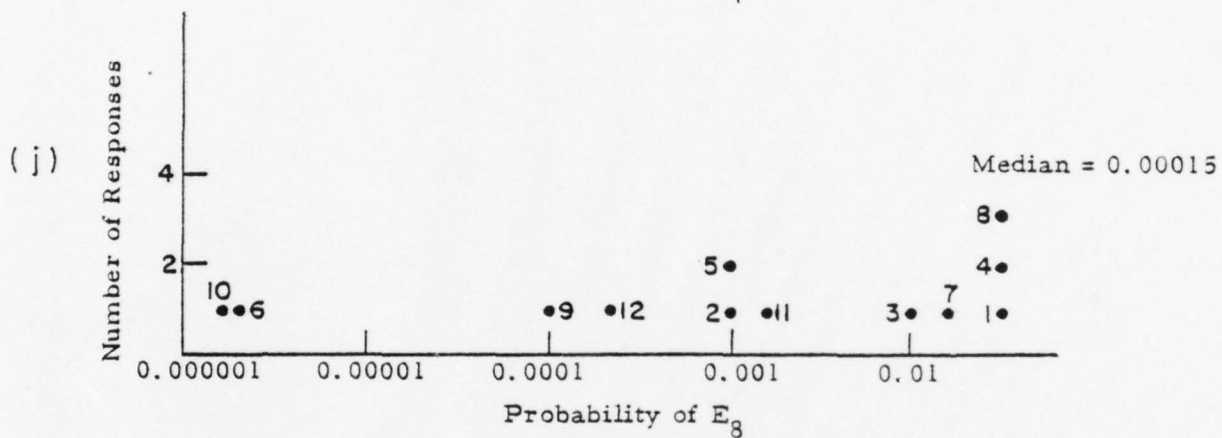
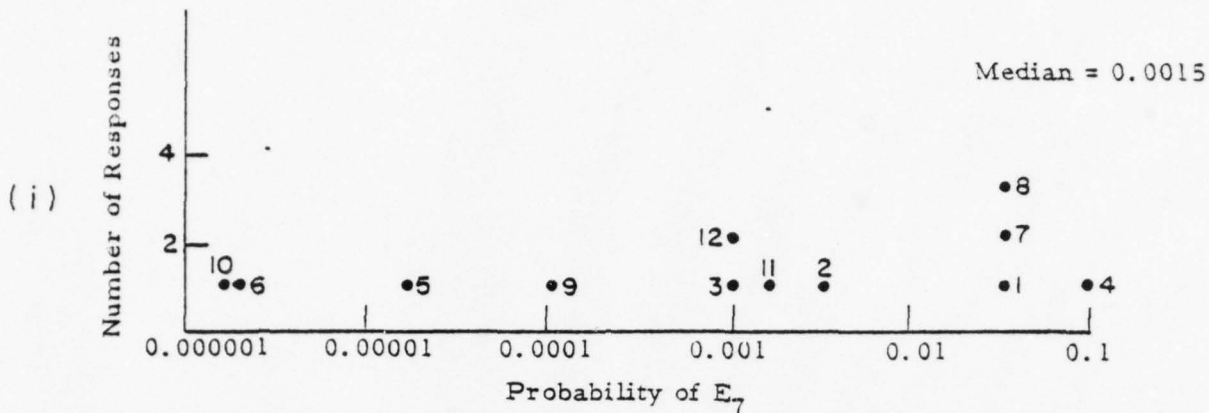

Figure B5. (continued)

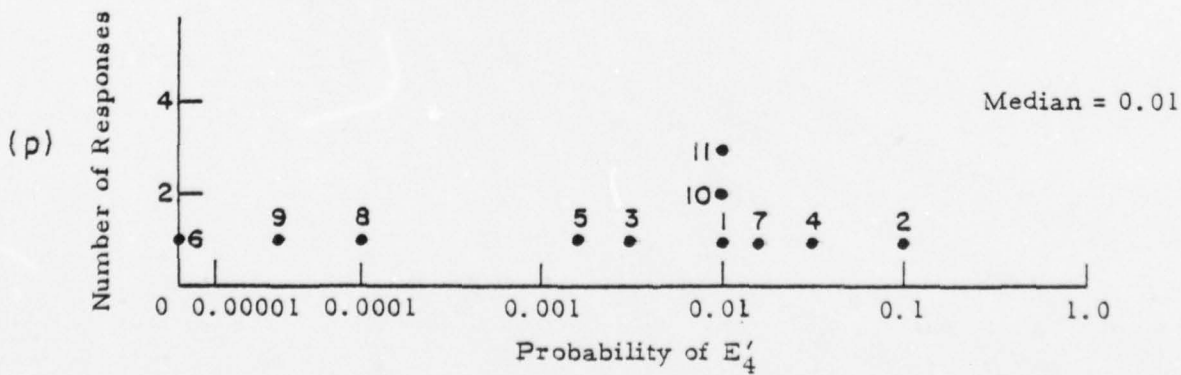
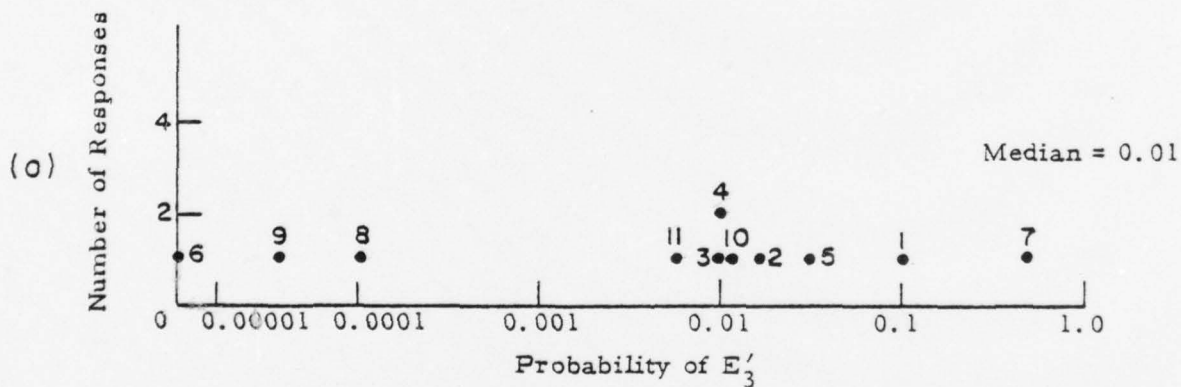
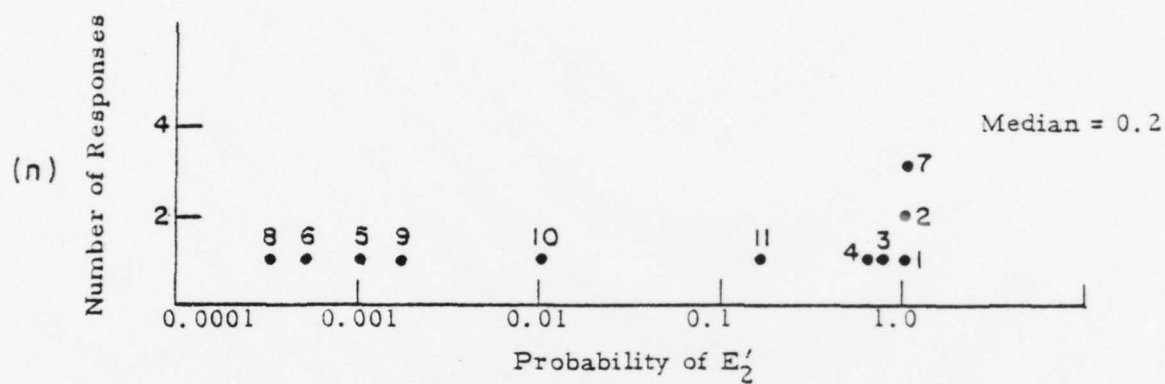
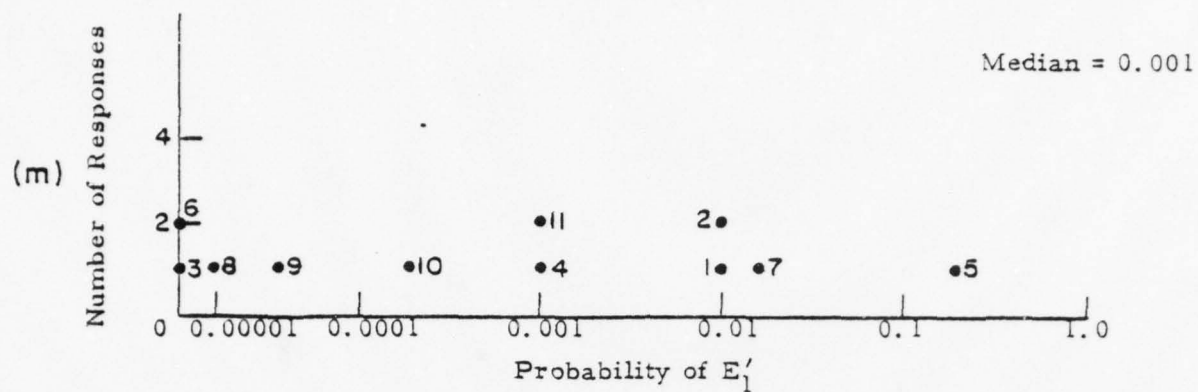

Figure B5. (continued)

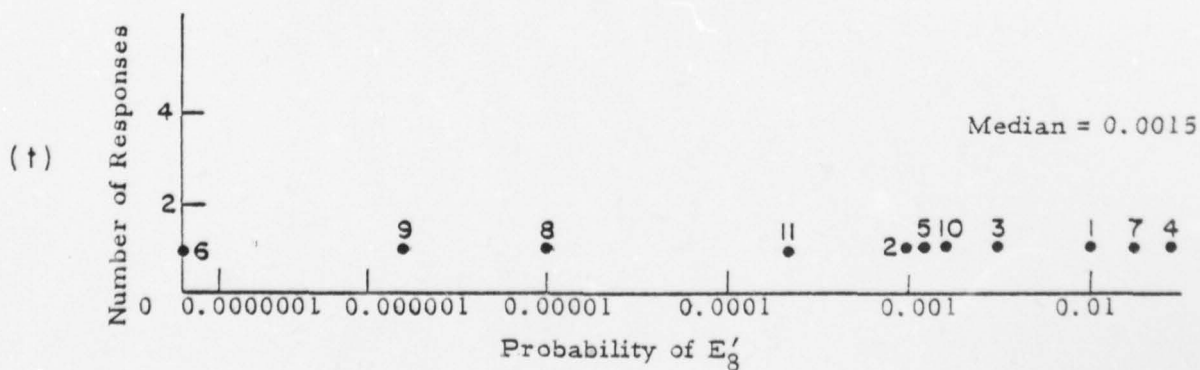
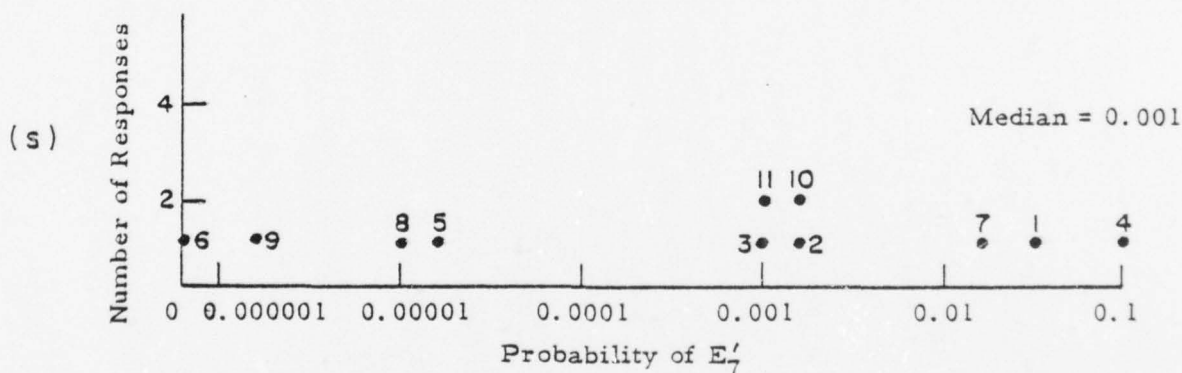
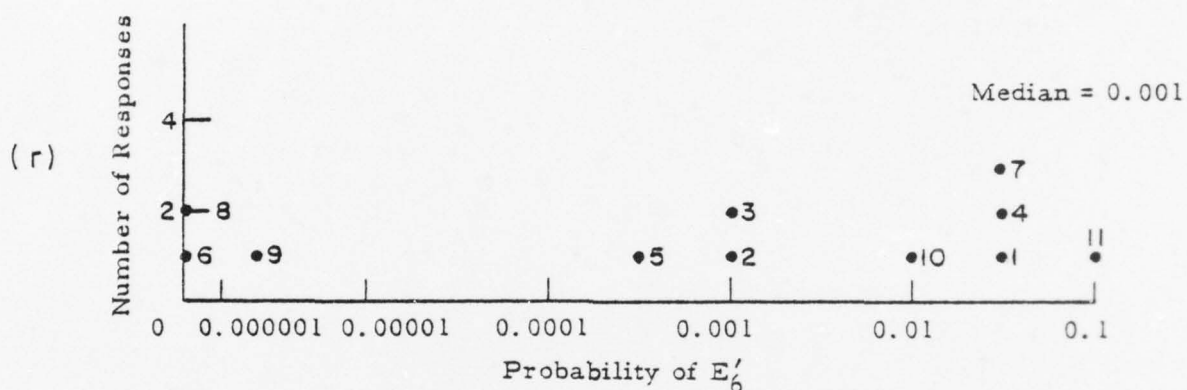
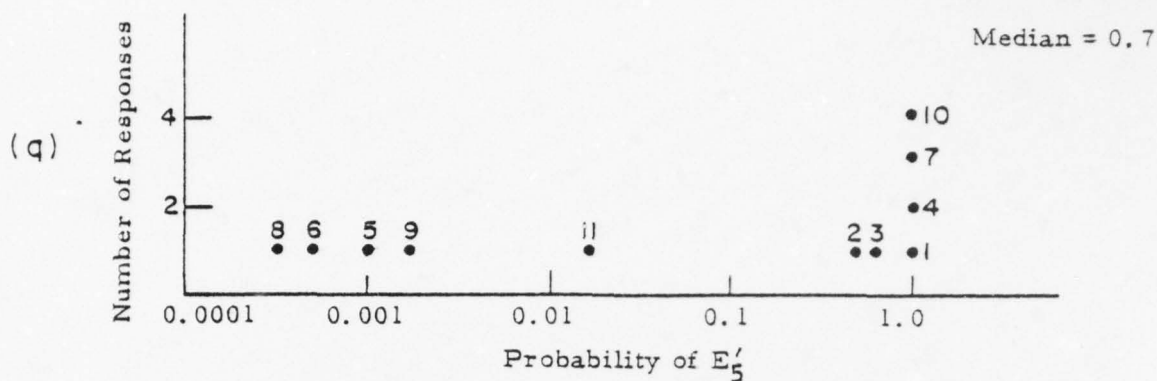

Figure B5. (continued)

APPENDIX C

TABLE C-1
ESTIMATED PROBABILITY OF THE EVENT
 (First Round Grounded Type)

Expert Event*	1	2	3	4	5	6	7	8	9	10	11	12
E _g	0.5	0.5	0.75	0.5	0.5	0.005	1.0	0.9	0.005	0.005	0.3	0.1
E ₀	0.25	0.1	0.1	0.01	0.0001	0.00028	0.66	0.8	0.0001	0.0045	0.0225	0.878
E ₁	0.05	0.01	0.001	0.001	0.5	0	0.1	0.2	0.0001	0.0001	0.00028	0.001
E ₂	1.0	1.0	0.9	0.8	0.001	0.007	1.0	1.0	0.005	0.0055	0.01	0.2
E ₃	0.1	0.05	0.01	0.01	0.05	0.0007	0.1	0.7	0.0001	0.0001	0.0125	0.0078
E ₄	0.05	0.1	0.005	0.05	0.002	0.00007	0.05	0.05	0.0001	0.00015	0.01	0.01
E ₅	1.0	0.7	0.8	1.0	0.001	0.007	1.0	1.0	0.005	0.006	1.0	0.022
E ₆	0.35	0.2	0.2	0.2	0.65	0.0035	0.6	0.75	0.005	0.0015	0.425	0.6
E ₇	0.05	0.005	0.001	0.1	0.00002	0.000003	0.05	0.05	0.0001	0.000002	0.002	0.001
E ₈	0.05	0.001	0.01	0.05	0.001	0.000003	0.02	0.05	0.0001	0.000002	0.002	0.00035

TABLE C-2
 ESTIMATED PROBABILITY OF THE EVENT
 (First Round Doubly Insulated Type)

Expert Event#	1	2	3	4	5	6	7	8	9	10	11
E _g '	0.5	0.5	0.75	0.5	0.5	0.00005	0.9	0.0005	0.002	0.3	0.1
E ₀ '	0.25	0.1	0.1	0.01	0.0001	0.00003	0.8	0.00001	0.0018	0.0225	0.878
E ₁ '	0.01	0.01	0	0.001	0.3	0	0.02	0.00001	0.00004	0.00028	0.001
E ₂ '	1.0	1.0	0.9	0.8	0.001	0.0007	1.0	0.0005	0.0022	0.01	0.2
E ₃ '	0.1	0.02	0.01	0.01	0.05	0	0.7	0.0001	0.00004	0.0125	0.0078
E ₄ '	0.01	0.1	0.005	0.05	0.002	0	0.02	0.0001	0.00004	0.01	0.01
E ₅ '	1.0	0.7	0.8	1.0	0.001	0.0007	1.0	0.0005	0.0022	1.0	0.022
E ₆ '	0.05	0.001	0.001	0.05	0.0005	0	0.05	0	0.000002	0.01	0.1
E ₇ '	0.05	0.002	0.001	0.1	0.00002	0	0.02	0.00001	0.000002	0.002	0.001
E ₈ '	0.01	0.001	0.005	0.05	0.0015	0	0.02	0.00001	0.000002	0.002	0.00035

TABLE C-3
PROBABILITY SUMMARY FOR TABLE C-1
(First Round)

Event	Lowest Estimate	Highest Estimate	Median
E_g	0.005	1.0	0.5
E_0	0.0001	0.878	0.095
E_1	0	0.5	0.001
E_2	0.001	1.0	0.5
E_3	0.0001	0.7	0.0113
E_4	0.00007	0.1	0.01
E_5	0.0001	1.0	0.75
E_6	0.0015	0.75	0.275
E_7	0.000002	0.1	0.0015
E_8	0.000002	0.05	0.00015

TABLE C-4
PROBABILITY SUMMARY FOR TABLE C-2
(First Round)

Event	Lowest Estimate	Highest Estimate	Median
E' _g	0.00005	0.9	0.5
E' ₀	0.00001	0.878	0.0225
E' ₁	0	0.3	0.001
E' ₂	0.0005	1.0	0.2
E' ₃	0	0.7	0.01
E' ₄	0	0.1	0.01
E' ₅	0.0005	1.0	0.7
E' ₆	0	0.1	0.001
E' ₇	0	0.1	0.001
E' ₈	0	0.05	0.0015

TABLE C-5

ESTIMATED PROBABILITY OF THE EVENT
(Second Round with Safety Mandate, Grounded Type)

Expert Event	1	2	3	4	5	6	7
E _g	0.05	0.05	0.08	0.08	0.2	0.5	0.25
E ₀	0.1	0.0001	0.005	0.0005	0.005	0.0001	0.25
E ₁	0.001	0.00001	0.012	0.01	0.008	0.5	0.0005
E ₂	1.0	0.0001	1.0	1.0	1.0	0.001	1.0
E ₃	0.01	0.005	0.008	0.008	0.008	0.05	0.05
E ₄	0.04	0.002	0.0005	0.00003	0.001	0.002	0.02
E ₅	0.4	0.01	1.0	1.0	0.7	0.001	0.25
E ₆	0.4	0.1	0.5	0.7	0.5	0.65	0.25
E ₇	0.001	0.0001	0.00001	0.000001	0.00001	0.001	0.02
E ₈	0.001	0.0001	0.00005	0.00001	0.00003	0.001	0.01

TABLE C-6

ESTIMATED PROBABILITY OF THE EVENT
(Second Round with Safety Mandate, Doubly Insulated Type)

Expert Event	1	2	3	4	5	6	7
E' _g	0.05	0.05	0.08	0.08	0.2	0.5	0.25
E' ₀	0.1	0.0001	0.005	0.0005	0.005	0.0001	0.25
E' ₁	0.001	0.00001	0.012	0.01	0.008	0.3	0.0001
E' ₂	1.0	0.0001	1.0	1.0	1.0	0.001	1.0
E' ₃	0.005	0.005	0.008	0.008	0.008	0.05	0.05
E' ₄	0.05	0.002	0.0005	0.00003	0.001	0.002	0.001
E' ₅	0.1	0.01	1.0	1.0	0.7	0.001	0.15
E' ₆	0.001	0.00001	0.01	0.01	0.008	0.0005	0.01
E' ₇	0.0001	0.000001	0.00001	0.000001	0.00001	0.00002	0.01
E' ₈	0.0001	0.0001	0.00005	0.00001	0.00003	0.0015	0.001

TABLE C-7

SUMMARY FOR TABLE C-5
(Second Round with Safety Mandate)

Event	Lowest Estimate	Highest Estimate	Median
E _g	0.05	0.5	0.08
E ₀	0.0001	0.25	0.005
E ₁	0.00001	0.5	0.008
E ₂	0.0001	1.0	1.0
E ₃	0.005	0.05	0.008
E ₄	0.00003	0.04	0.002
E ₅	0.001	1.0	0.4
E ₆	0.1	0.7	0.5
E ₇	0.000001	0.02	0.0001
E ₈	0.00001	0.01	0.0001

TABLE C-8

SUMMARY FOR TABLE C-6
(Second Round with Safety Mandate)

Event	Lowest Estimate	Highest Estimate	Median
E' _g	0.05	0.5	0.08
E' ₀	0.0001	0.25	0.005
E' ₁	0.00001	0.3	0.008
E' ₂	0.0001	1.0	1.0
E' ₃	0.005	0.05	0.008
E' ₄	0.00003	0.05	0.002
E' ₅	0.001	1.0	0.15
E' ₆	0.00001	0.01	0.008
E' ₇	0.000001	0.01	0.00001
E' ₈	0.00001	0.001	0.0001

TABLE C-9
(Second Round Without Safety Mandate)

Event	Lowest Estimate	Highest Estimate	Median
E_g	0.05	0.5	0.5
E_0	0.0001	0.25	0.1
E_1	0.00001	0.05	0.01
E_2	0.0001	1.0	1.0
E_3	0.005	0.05	0.01
E_4	0.002	0.05	0.05
E_5	0.8	1.0	1.0
E_6	0.1	0.4	0.25
E_7	0.0001	0.005	0.01
E_8	0.0001	0.05	0.001

TABLE C-10

(Second Round Without Safety Mandate)

Event	Lowest Estimate	Highest Estimate	Median
E' _g	0.05	0.5	0.5
E' ₀	0.0001	0.25	0.1
E' ₁	0.00001	0.01	0.01
E' ₂	0.0001	1.0	1.0
E' ₃	0.005	0.05	0.005
E' ₄	0.002	0.05	0.01
E' ₅	0.4	1.0	1.0
E' ₆	0.00001	0.01	0.001
E' ₇	0.000001	0.01	0.0001
E' ₈	0.0001	0.01	0.0001

TABLE C-11
OPTIMIST/PESSIMIST CLASSIFICATION OF EXPERTS
 (Grounded Type)

Event Expert	E ₈	E ₀	E ₁	E ₂	E ₃	E ₄	E ₅	E ₆	E ₇	E ₈	P/10
1	P	P	P	P	P	P	P	P	P	P	1
2	P	P	P	P	P	P	P	P	P	P	1
3	P	P	O	P	P	P	P	P	P	P	0.9
4	P	P	O	P	P	P	P	P	P	P	0.9
5	P	O	P	O	P	O	O	P	O	P	0.5
6	O	O	O	O	O	O	O	O	O	O	0.0
7	P	P	P	P	P	P	P	P	P	P	1
8	P	P	P	P	P	P	P	P	P	P	1
9	O	O	O	O	O	O	O	O	O	O	0.0
10	O	O	O	O	O	O	O	O	O	O	0.0
11	P	P	O	O	P	P	P	P	P	P	0.8
12	P	P	O	P	O	P	O	P	P	P	0.7

TABLE C-12
OPTIMIST/PESSIMIST CLASSIFICATION OF EXPERTS
 (Doubly Insulated Type)

Event Expert	E' ₈	E' ₀	E' ₁	E' ₂	E' ₃	E' ₄	E' ₅	E' ₆	E' ₇	E' ₈	P/10
1	P	P	P	P	P	P	P	P	P	P	1.0
2	P	P	P	P	P	P	P	P	P	P	1.0
3	P	P	O	P	P	P	P	P	P	P	0.9
4	P	P	O	P	P*	P	P	P	P	P	0.9
5	P	O	P	O	P	P	O	P	O	P	0.6
6	O	O	O	O	O	O	O	O	O	O	0.0
7	P	P	P	P	P	P	P	P	P	P	1.0
8	O	O	O	O	O	O	O	O	O	O	0.0
9	P	O	O	O	O	O	O	O	O	O	0.1
10	P	P	O	O	P	P	P	P	P	P	0.8
11	P	P	O	P	P	P	O	P	P	P	0.8

TABLE C-13

SUMMARY STATISTICS OF OPTIMIST/PESSIMIST SEPARATED DATA

Event	Geometric Mean	High Median	Low Median
E _g	0.0707	0.5	0.005
E ₀	0.00937	0.175	0.00019
E ₁	0.00707	0.1	0.00028
E ₂	0.0316	1.0	0.0055
E ₃	0.00837	0.05	0.0004
E ₄	0.00265	0.05	0.000125
E ₅	0.0316	1.0	0.006
E ₆	0.0335	0.425	0.0035
E ₇	0.000447	0.275	0.0000115
E ₈	0.000316	0.01	0.000003

C-13
TABLE C-14

SUMMARY STATISTICS OF OPTIMIST/PESSIMIST SEPARATED DATA

Event	Geometric Mean	High Median	Low Median
E'_g	0.000571	0.5	0.000275
E'_0	0.00296	0.1	0.000065
E'_1	0.00173	0.015	0.00004
E'_2	0.0223	0.95	0.001
E'_3	0.00529	0.0163	0.00004
E'_4	0.002	0.015	0.00004
E'_5	0.0223	1.0	0.001
E'_6	0.000316	0.0015	0
E'_7	0.000447	0.002	0.000006
E'_8	0.000316	0.0035	0.000005

TABLE C-15

AVERAGE DISTANCE CLUSTERING COMPUTATIONS

E_g	$\log E_g$	Experts	Distance Between log Estimate
0.005	-2.3010	6, 9, 10	> 1.301
0.1	-1.0	12	> 0.4771
0.3	-0.5229	11	> 0.2219
0.5	-0.3010	1, 2, 4, 5	> 0.1761
0.75	-0.1249	3	> 0.0791
0.9	-0.0458	8	> 0.0458
1.0	0	7	

$$D = \text{Average Distance} = \frac{2.3010}{12} = 0.1917 \approx 0.192$$

$$3D = 0.576$$

$$\text{Cluster 1} = 6, 9, 10$$

$$\text{Cluster 2} = 1, 2, 3, 4, 5, 7, 8, 11, 12$$

TABLE C-16

AVERAGE DISTANCE CLUSTERING COMPUTATIONS

E_0	$\log E_0$	Expert	Distance
0.0001	-4.0	5, 9	> 0.4472
0.00028	-3.5528	6	> <u>1.206</u>
0.0045	-2.3468	10	> 0.3468
0.01	-2.0	4	> 0.3522
0.0225	-1.6478	11	> 0.6478
0.1	-1.0	2, 3	> 0.3979
0.25	-0.6021	1	> 0.4150
0.66	-0.1871	7	> 0.0902
0.8	-0.0969	8	> 0.0404
0.876	-0.0565	12	> 0.0404

$$\text{Average distance} = \frac{3.9435}{12} = 0.3286 \approx 0.329$$

$$3D = 0.987$$

$$\text{Cluster 1} \equiv 5, 6, 9$$

$$\text{Cluster 2} \equiv 1, 2, 3, 4, 7, 8, 10, 11, 12$$

TABLE C-17

AVERAGE DISTANCE CLUSTERING COMPUTATIONS

E_1	$\log E_1$	Experts	Distance
0.0001	-4.0	9, 10	> 0.4472
0.00028	-3.5528	11	> 0.5528
0.001	-3.00	3, 4, 12	> 1.0
0.01	-2.0	2	> 0.699
0.05	-1.3010	1	> 0.3010
0.1	-1.0	7	> 0.3010
0.2	-0.6990	8	> 0.301
0.5	-0.3010	5	> 0.398
0		6	not considered

$$D = \text{Distance} = \frac{3.699}{12} = 0.3083 \approx 0.308$$

$$3D = 0.924$$

Cluster 1 = 3, 4, 9, 10, 11, 12

Cluster 2 = 1, 2, 5, 7, 8

TABLE C-18

AVERAGE DISTANCE CLUSTERING COMPUTATIONS

E_2	$\log E_2$	Experts	Distance
0.001	-3.0	5	> 0.699
0.005	-2.3010	9	> 0.0414
0.0055	-2.2596	10	> <u>0.1047</u>
0.007	-2.1549	6	> 0.1549
0.01	-2.0	11	> <u>1.301</u>
0.2	-0.6990	12	> 0.6021
0.8	-0.0969	4	> 0.0511
0.9	-0.0458	3	> 0.0458
1.0	0	1, 2, 7, 8	> 0.0458

$$D = \text{Distance} = \frac{3.0}{12} = 0.25$$

$$3D = 0.75$$

Cluster 1 = 5, 9, 10

Cluster 2 = 6, 11

Cluster 3 = 1, 2, 3, 4, 7, 8, 12

TABLE C-19

AVERAGE DISTANCE CLUSTERING COMPUTATIONS

E_3	$\log E_3$	Experts	Distance
0.0001	-4.0	9, 10	> 0.8451
0.0007	-3.1549	6	> 0.047
0.0078	-2.1079	12	> 0.1079
0.01	-2.0	3, 4	> 0.0969
0.0125	-1.9031	11	> 0.6021
0.05	-1.3010	2, 5	> 0.3010
0.1	-1.0	1, 7	> 0.8451
0.7	-0.1549	8	

$$D = \frac{3.8451}{12} = 0.3304 \approx 0.33$$

$$3D = 0.99$$

Cluster 1 = 1, 2, 3, 4, 5, 6, 7, 8, 9, 10, 11, 12

TABLE C-20

AVERAGE DISTANCE CLUSTERING COMPUTATIONS

E_4	$\log E_4$	Experts	Distance
0.00007	-4.1549	6	> 0.1549
0.0001	-4.0	9	> 0.1761
0.00015	-3.8239	10	> <u>1.1249</u>
0.002	-2.699	5	> 0.398
0.005	-2.3010	3	> 0.301
0.01	-2.0	11, 12	> 0.699
0.05	-1.3010	1, 4, 7, 8	> 0.301
0.1	-1.0	2	

$$D = \text{Average Distance} = \frac{3.1549}{12} = 0.2629 \approx 0.263$$

$$3D = 0.789$$

Cluster 1 # 6, 9, 10

Cluster 2 # 1, 2, 3, 4, 5, 7, 8, 11, 12

TABLE C-21

AVERAGE DISTANCE CLUSTERING COMPUTATIONS

E_5	$\log E_5$	Experts	Distance
0.001	-3.0	5	>0.699
0.005	-2.3010	9	>0.0792
0.006	-2.2218	10	>0.0669
0.007	-2.1549	6	>0.4973
0.022	-1.6576	12	> <u>1.5027</u>
0.7	-0.1549	2	>0.058
0.8	-0.0969	3	>0.0969
1.0	0	1, 4, 7, 8, 11	>0.0969

$$D = \text{Average Distance} = \frac{3}{12} = 0.25$$

$$3D = 0.75$$

Cluster 1 = 5, 6, 9, 10, 12

Cluster 2 = 1, 2, 3, 4, 7, 8, 11

TABLE C-22

AVERAGE DISTANCE CLUSTERING COMPUTATIONS

E_6	$\log E_6$	Experts	Distance
0.0015	-2.8239	10	> 0.3680
0.0035	-2.4559	6	> 0.1549
0.005	-2.3010	9	> <u>1.6020</u>
0.2	-0.6990	2, 3, 4,	> 0.2431
0.35	-0.4559	1	> 0.0843
0.425	-0.3716	11	> 0.1498
0.6	-0.2218	7, 12	> 0.0347
0.65	-0.1871	5	> 0.0622
0.75	-0.1249	8	

$$D = \text{Average Distance} = \frac{2.699}{12} = 0.225$$

$$3D = 0.675$$

Cluster 1 \equiv 6, 9, 10

Cluster 2 \equiv 1, 2, 3, 4, 5, 7, 8, 11, 12

TABLE C-23

AVERAGE DISTANCE CLUSTERING COMPUTATIONS

E_7	$\log E_7$	Experts	Distance
0.000002	-5.6990	10	> 0.1761
0.000003	-5.5229	6	> 0.8239
0.00002	-4.6990	5	> 0.6990
0.0001	-4.0	9	> 1.0
0.001	-3.0	3, 12	> 0.3010
0.002	-2.6990	11	> 0.3980
0.005	-2.3010	2	> 1.0
0.05	-1.3010	1, 7, 8	> 0.3010
0.1	-1.0	4	

$$D = \frac{4.699}{12} = 0.3916 \quad 0.392$$

$$3D = 1.176$$

Cluster 1 = 1, 2, 3, 4, 5, 6, 7, 8, 9, 10, 11, 12

TABLE C-24

AVERAGE DISTANCE CLUSTERING COMPUTATIONS

E_8	$\log E_8$	Experts	Distance
0.000002	-5.6990	10	> 0.1761
0.000003	-5.5229	6	> <u>1.5229</u>
0.0001	-4.0	9	> 0.5441
0.00035	-3.4559	12	> 0.4559
0.001	-3.0	2, 5	> 0.3010
0.002	-2.6990	11	> 0.6990
0.01	-2.0	3	> 0.3010
0.02	-1.6990	7	> 0.3980
0.05	-1.3010	1, 4, 8	

$$D = \frac{4.398}{12} = 0.3665 \approx 0.366$$

$$3D = 1.098 \quad 1.1$$

Cluster 1 = 6, 10

Cluster 2 = 1, 2, 3, 4, 5, 7, 8, 9, 11, 12

TABLE C-25

AVERAGE DISTANCE CLUSTERING COMPUTATIONS

E'_g	$\log E'_g$	Experts	Distance
0.00005	-4.3010	6	> 1.0
0.0005	-3.3010	8	> 0.602
0.002	-2.6990	9	> <u>1.699</u>
0.1	-1.0	11	> 0.4771
0.3	-0.5229	10	> 0.2219
0.5	-0.3010	1, 2, 4, 5	> 0.1761
0.75	-0.1249	3	> 0.1761
0.9	-0.0458	7	

$$D = \text{Average distance} = \frac{4.2552}{11} = 0.3868 \approx 0.387$$

$$3D = 1.161$$

Cluster 1 \equiv 6, 8, 9

Cluster 2 \equiv 1, 2, 3, 4, 5, 7, 10, 11

TABLE C-26

AVERAGE DISTANCE CLUSTERING COMPUTATIONS

E'_0	$\log E'_0$	Experts	Distance
0.00001	-5.0	8	> 0.4771
0.00003	-4.5229	6	> 0.5229
0.0001	-4.0	5	> 1.2553
0.0018	-2.7447	9	> 0.7447
0.01	-2.0	4	> 0.3522
0.0225	-1.6478	10	> 0.6478
0.1	-1.0	2, 3	> 0.3979
0.25	0.6021	1	> 0.5052
0.8	0.0969	7	> 0.0404
0.878	0.0565	11	

$$D = \frac{4.9435}{11} = 0.4494 \approx 0.45$$

$$3D = 1.35$$

Cluster 1 = 1, 2, 3, 4, 5, 6, 7, 8, 9, 10, 11

TABLE C-27

AVERAGE DISTANCE CLUSTERING COMPUTATIONS

E'_1	$\log E'_1$	Experts	Distance
0.00001	-5.0	8	> 0.6021
0.00004	-4.3979	9	> 0.8451
0.00028	-3.5528	10	> 0.5528
0.001	-3.0	4, 11	> 1.0
0.01	-2.0	1, 2	> 0.301
0.02	-1.6990	7	> 1.1761
0.3	0.5229	5	
0		3, 6	Not Considered

$$D = \frac{4.4771}{9} = 0.4975 \approx 0.5$$

$$3D = 1.5$$

Cluster 1 = 1, 2, 4, 5, 7, 8, 9, 10, 11

TABLE C-28

AVERAGE DISTANCE CLUSTERING COMPUTATIONS

E'_2	$\log E'_2$	Experts	Distance
0.0005	-3.3010	8	> 0.1461
0.0007	-3.1549	6	> 0.1549
0.001	-3.0	5	> 0.3424
0.0022	-2.6576	9	> 0.6576
0.01	-2.0	10	> <u>1.301</u>
0.2	0.6990	11	> 0.6021
0.8	0.0969	4	> 0.0511
0.9	0.0458	3	> 0.0458
1.0	0	1, 2, 7	

$$D = \frac{3.301}{11} = 0.3001 \approx 0.3$$

$$3D = 0.9$$

Cluster 1 = 5, 6, 8, 9, 10

Cluster 2 = 1, 2, 3, 4, 7, 11

TABLE C-29

AVERAGE DISTANCE CLUSTERING COMPUTATIONS

E'_3	$\log E'_3$	Experts	Distance
0.00004	-4.3979	9	> 0.3979
0.0001	-4.0	8	> <u>1.8921</u>
0.0078	-2.1079	11	> 0.1079
0.01	-2.0	3, 4	> 0.0969
0.0125	-1.9031	10	> 0.2041
0.02	-1.6990	2	> 0.3980
0.05	-1.3010	5	> 0.3010
0.1	-1.0	1	> 0.8451
0.7	-0.1549	7	
0		6	Not Considered

$$D = \frac{4.2430}{10} = 0.4243 \approx 0.424$$

$$3D = 1.272$$

Cluster 1 = 8,9

Cluster 2 = 1, 2, 3, 4, 5, 7, 10, 11

TABLE C-30
AVERAGE DISTANCE CLUSTERING COMPUTATIONS

E'_4	$\log E'_4$	Experts	Distance
0.00004	-4.3979	9	> 0.3979
0.0001	-4.0	8	> <u>1.301</u>
0.002	-2.6990	5	> 0.398
0.005	-2.3010	3	> 0.301
0.01	-2.0	1, 10, 11	> 0.301
0.02	-1.699	7	> 0.398
0.05	-1.301	4	> 0.301
0.1	-1.0	2	> 0.301
0		6	Not Considered

$$D = \frac{3.3979}{10} = 0.3398 \simeq 0.34$$

$$3D = 1.02$$

Cluster 1 = 8, 9

Cluster 2 = 1, 2, 3, 4, 5, 7, 10, 11

TABLE C-31

AVERAGE DISTANCE CLUSTERING COMPUTATIONS

E'_5	$\log E'_5$	Experts	Distance
0.0005	-3.3010	8	> 0.1461
0.0007	-3.1549	6	> 0.1549
0.001	-3.0	5	> 0.3424
0.0022	-2.6576	9	> <u>1.00</u>
0.022	-1.6576	11	> <u>1.5027</u>
0.7	0.1549	2	> 0.058
0.8	0.0969	3	> 0.0969
1.0	0	1, 4, 7, 10	

$$D = \frac{3.301}{11} = 0.3001 \approx 0.3$$

$$3D = 0.9$$

Cluster 1 \equiv 5, 6, 8, 9

Cluster 2 \equiv 11

Cluster 3 \equiv 1, 2, 3, 4, 7, 10

TABLE C-32

AVERAGE DISTANCE CLUSTERING COMPUTATIONS

E'_6	$\log E'_6$	Experts	Distance
0.000002	-5.6990	9	> <u>2.398</u>
0.0005	-3.3010	5	> 0.301
0.001	-3.0	2, 3	> 1.0
0.01	-2.0	10	> 0.699
0.05	-1.3010	1, 4, 7	> 0.301
0.1	-1.0	11	
0		6, 8	Not Considered

$$D = 0.5221 \approx 0.522$$

$$3D = 1.566$$

$$\text{Cluster 1} \equiv 9$$

$$\text{Cluster 2} \equiv 1, 2, 3, 4, 5, 7, 10, 11$$

TABLE C-33
AVERAGE DISTANCE CLUSTERING COMPUTATIONS

E'_7	$\log E'_7$	Experts	Distance
0.000002	-5.6990	9	> 0.699
0.00001	-5.0	8	> 0.301
0.00002	4.6990	5	> <u>1.699</u>
0.001	-3.0	3, 11	> 0.301
0.002	-2.6990	2, 10	> 1.0
0.02	-1.6990	7	> 0.398
0.05	-1.3010	1	> 0.301
0.1	-1.0	4	
0		6	Not Considered

$$D = \frac{4.699}{10} = 0.4699 \approx 0.47$$

$$3D = 1.41$$

Cluster 1 \equiv 5, 8, 9

Cluster 2 \equiv 1, 2, 3, 4, 7, 10, 11

TABLE C-34

AVERAGE DISTANCE CLUSTERING COMPUTATIONS

E'_8	$\log E'_8$	Experts	Distance
0.000002	-5.6990	9	> 0.699
0.00001	-5.0	8	> <u>1.5441</u>
0.00035	-3.4559	11	> 0.4559
0.001	-3.0	2	> 0.1761
0.0015	-2.8239	5	> 0.1249
0.002	-2.6990	10	> 0.398
0.005	-2.3010	3	> 0.301
0.01	-2.0	1	> 0.301
0.02	-1.6990	7	> 0.398
0.05	-1.3010	4	
0		6	Not Considered

$$D = \frac{4.398}{10} = 0.4398 \approx 0.44$$

$$3D = 1.32$$

Cluster 1 = 8, 9

Cluster 2 = 1, 2, 3, 4, 5, 7, 10, 11