

AD-A062 519

COLD REGIONS RESEARCH AND ENGINEERING LAB HANOVER N H F/G 13/13  
ROOF CONSTRUCTION UNDER WINTERTIME CONDITIONS: A CASE STUDY.(U)  
NOV 78 F L BENNETT

UNCLASSIFIED

CRREL-SR-78-24

NL

AD  
A062519



END  
DATE  
FILMED  
3-79  
DDC

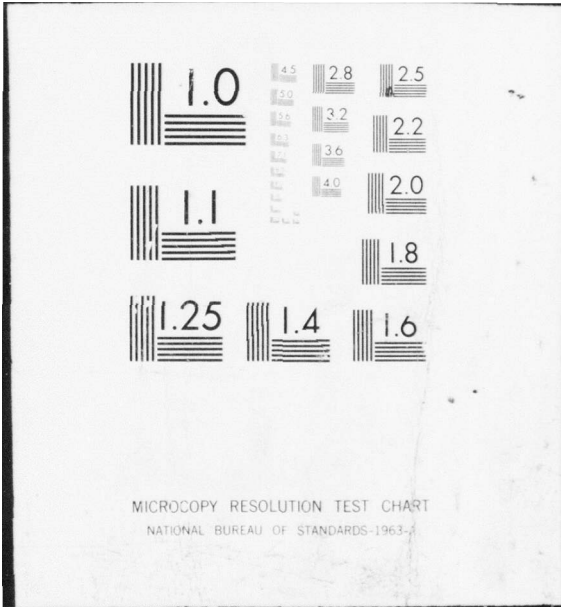

AD A0 62519

Special Report 78-24

November 1978

12  
NW



ROOF CONSTRUCTION UNDER WINTERTIME CONDITIONS: A CASE STUDY

F. Lawrence Bennett

DDC  
DEC 26 1978

DDC FILE COPY

OFFICE, CHIEF OF ENGINEERS

By



DEPARTMENT OF THE ARMY  
COLD REGIONS RESEARCH AND ENGINEERING LABORATORY  
CORPS OF ENGINEERS  
HANOVER, NEW HAMPSHIRE

Approved for public release; distribution unlimited.

78 12 18 055

SECURITY CLASSIFICATION OF THIS PAGE (When Data Entered)

9 REPORT DOCUMENTATION PAGE		READ INSTRUCTIONS BEFORE COMPLETING FORM
1. REPORT NUMBER Special Report, 78-24	2. GOVT ACCESSION NO.	3. RECIPIENT'S CATALOG NUMBER
4. TITLE (and Subtitle) ROOF CONSTRUCTION UNDER WINTERTIME CONDITIONS: A CASE STUDY,		5. TYPE OF REPORT & PERIOD COVERED
		6. PERFORMING ORG. REPORT NUMBER
7. AUTHOR(s) F. Lawrence Bennett		8. CONTRACT OR GRANT NUMBER(s)
9. PERFORMING ORGANIZATION NAME AND ADDRESS U.S. Army Cold Regions Research and Engineering Laboratory Hanover, New Hampshire 03755		10. PROGRAM ELEMENT, PROJECT, TASK AREA & WORK UNIT NUMBERS DA Project 4A762730AT42 Task A3, Work Unit 013
11. CONTROLLING OFFICE NAME AND ADDRESS Directorate of Military Programs Office, Chief of Engineers Washington, D.C.		12. REPORT DATE November 1978
14. MONITORING AGENCY NAME & ADDRESS (If different from Controlling Office) 14) CRREL-SR-78-24		13. NUMBER OF PAGES 36
		15. SECURITY CLASS. (of this report) Unclassified
		15a. DECLASSIFICATION/DOWNGRADING SCHEDULE
16. DISTRIBUTION STATEMENT (of this Report) Approved for public release; distribution unlimited.		
17. DISTRIBUTION STATEMENT (of the abstract entered in Block 20, if different from Report)		
18. SUPPLEMENTARY NOTES		
19. KEY WORDS (Continue on reverse side if necessary and identify by block number) Construction Fairbanks, Alaska Performance Roofs Winter conditions		
20. ABSTRACT (Continue on reverse side if necessary and identify by block number) This report describes construction of the roof of an addition to the Interior City Branch of the First National Bank of Anchorage, located in downtown Fairbanks, Alaska, during the 1976-77 winter. The report documents the schedule and procedure for building the roof, reports successful performance of the roof to date, and presents some general comments on roof construction in the wintertime.		

037 100

78 12 18 055

LB

## PREFACE

This report was prepared by Professor F. Lawrence Bennett, Head, Department of Engineering and Science Management, and Assistant to the Chancellor, University of Alaska, Fairbanks, Alaska, for the U. S. Army Cold Regions Research and Engineering Laboratory (CRREL).

The study was funded under DA Project 4A762730AT42, Design, Construction and Operations Technology for Cold Regions; Task A3, Facilities Technology/Cold Regions; Work Unit 013, Cold Weather Performance of Protected Membrane Roofs; DA Purchase Order No. DACA89-78-0480.

Stephen Flanders and Edward F. Lobacz of CRREL reviewed the technical content of this report.

Several persons were most cooperative in providing information included in this report. George E. Smith, Assistant Cashier of the Interior City Branch, First National Bank of Anchorage, was enthusiastically supportive of the project and provided access to the bank and its roof on several occasions. Edwin Burbeck, of Burbeck Roofing Co., also provided much important information relative to the construction of the Interior City Branch addition.

The contents of this report are not to be used for advertising, or promotional purposes. Citation of brand names does not constitute an official endorsement or approval of the use of such commercial products.



TABLE OF CONTENTS

Preface .....	1
Introduction .....	1
Background .....	1
Project Description .....	2
Roofing Specifications .....	3
Roof Description .....	3
Roof Construction Activities .....	4
Roof Performance .....	5
Some General Comments on Roof Construction in the Wintertime ....	5
Photo Documentation .....	9
Summary and Conclusions .....	9
Literature Cited .....	9
Appendix A -- Project Specifications .....	11
Appendix B -- Details Showing Roof Design .....	21
Appendix C -- Photographs .....	23

## ROOF CONSTRUCTION UNDER WINTERTIME CONDITIONS: A CASE STUDY

### INTRODUCTION

On 8 December 1977, the U. S. Army Cold Regions Research and Engineering Laboratory authorized the University of Alaska School of Engineering to investigate the construction and subsequent performance of the roof of a bank building in downtown Fairbanks, Alaska. This authorization was based on a proposal submitted by the School of Engineering, University of Alaska, on 19 September 1977.

The project involved developing a description of the building project, obtaining drawings and specifications related to the roof of the bank building, ascertaining details on the construction schedule that was followed and the environmental conditions during that time, determining performance of the roof subsequent to its completion, and providing photo documentation of the building and its roof.

This report presents the result of the study, together with some general comments on roof construction in the wintertime, obtained during an interview with the roofing contractor who built the roof. The sections that follow include a background statement on the research project, a description of the bank building, a description of the roof under study, a discussion of the construction of the roof, a statement regarding the performance of the roof following its completion, and some general comments on roof construction in the wintertime.

### BACKGROUND

During the 1976-77 winter, the U. S. Army Cold Regions Research and Engineering Laboratory sponsored a research project under which the University of Alaska School of Engineering investigated and documented wintertime building construction activity in the Fairbanks area. The final report for that project (1) described nine building projects that were active during the 1976-77 winter in Fairbanks. This report described methods used for providing temporary enclosures and temporary

building heating during the construction process. In addition, the types of construction underway at various temperature conditions were reported, and a record of temperature variations in the buildings under construction was discussed.

While most of the buildings investigated during the 1976-77 winter were closed-in prior to the winter period, there was one significant exception. At the Interior City Branch of the First National Bank of Anchorage, located at 8th Avenue and Noble Street in downtown Fairbanks, much of the work was done "in the open." Included were steel erection, roof fascia installation, and roofing. Because "hot mopped" roofing is normally accomplished at temperatures above freezing, and because such a process was not employed at the Interior City Branch project, it was felt that further investigation, to develop a detailed description of the process by which that roof was constructed and its subsequent performance, was warranted.

This study was developed because of a need to add to the literature on cold regions construction some details regarding a process which is counter to the traditional methods by which roofs have been constructed in cold regions. The results of this study should provide owners and contractors with details on this little-documented trend in cold regions construction, with resulting savings in both time and money.

#### PROJECT DESCRIPTION

The building project whose roof was the subject of this study was an addition to and remodeling of the Interior City Branch of the First National Bank of Anchorage. The project is located at 8th Avenue and Noble Street in downtown Fairbanks, Alaska. The addition project covers two stories, with the first story providing parking and the second story providing offices, meeting rooms, storage and mechanical rooms, and an assembly area. Overall dimensions are approximately 90 ft by 75 ft, for a total area of 13,500 ft<sup>2</sup>. Project volume is 202,500 ft<sup>3</sup>.

Tate and Co. of Fairbanks was selected as general contractor for the project, with subcontractors including Rogers Electric Corp. and Chandalar Plumbing and Heating. Roofing subcontractor was Burbeck Roofing Co. of Fairbanks.

The structure includes a steel frame, brick exterior, and concrete floors. This project was of particular interest in a study of Fairbanks construction during the 1976-77 winter, as the general contractor chose to erect a polyethylene "shell" around the entire project and work within the enclosure several months during the winter. After the exterior walls were completed, the enclosure was removed and work proceeded "in the open" on the roof framing, deck, and thermal and moisture barriers.

The construction of the initial portion of the Interior City Branch facility was completed in 1973, utilizing plans and specifications dated 22 September 1972, prepared by John Graham and Co. of Anchorage, Alaska. The same specifications were utilized for the addition project, with modifications as necessary. John Graham Co. issued supplementary specifications for the addition to the bank on 20 August 1976. Construction began in the fall of 1976, continued through the 1976-77 winter, and was completed during 1977.

#### ROOFING SPECIFICATIONS

Appendix A contains sections of the project specifications relating to built-up roofing, roof insulation and roofing sheer metal. The first eight pages of the appendix are from the original specifications which, unless modified, applied to construction of the addition. The ninth page explains the use of supplementary specifications for the addition, and the tenth page indicates modifications to the specifications relating to built-up roofing, roof insulation and roofing sheetmetal. It will be noted that these supplementary specifications contain one change to the original specifications--changing the C factor of roof insulation--and one addition--relating to the removal of the existing roof system.

It should be noted that Section 7A.01B of the specifications stipulates a two-year guarantee on roofing construction. This provision is a standard part of most roofing specifications, both in Alaska and in warmer areas of the United States, although some documents for work in the Fairbanks area are currently requiring a five-year guarantee.

Section 7A.01C specifies that manufacturer's specifications "shall be considered a part of this Section." Generally, such manufacturer's specifications do not prohibit cold weather application of roofing materials. Such prohibition, if any, is contained in the specifications prepared by the architect/engineer. In the case of the Interior City Branch Addition project, no such clause was included in the specifications.

#### ROOF DESCRIPTION

The roofing system is a Class 1 insulated, fire-retardant, built-up roof with a one-hour building classification, placed over a 1 1/2 - in. 20-gauge steel deck. Vapor barrier over the metal deck is Sisalkraft 298 Vapor Stop installed with Sisalkraft 425 Pyroclure Adhesive. Over the vapor barrier were placed two layers of Fiberglas insulation, one 1-5/8-in. thick and one 1-3/16-in. thick. Joints on the insulation were taped, and the perimeter was nailed 4 ft inside the perimeter for protection from wind uplift. Over the insulation were placed two layers

of bituminous woven glass fabric, covered with two layers of 15 lb asphalt-saturated asbestos felt. Plain asphalt was used between roofing plies and as surfacing.

Appendix B contains a roof parapet detail, indicating the roof configuration at typical parapet wall, and a roof drain detail. It should be noted that these design details do not identify a location for a vapor barrier; however, Sections 7A.02A, 7A.02C, 7A.02D, and 7A.04B of the specifications clearly indicate that a vapor barrier is to be installed.

#### ROOF CONSTRUCTION ACTIVITIES

The Interior City Branch addition roof was constructed during mid-winter--14 January to 11 February 1977. Although temperatures averaged considerably higher than normal, conditions during some of this period could nonetheless be considered as "wintertime." Table I, entitled "Roofing Construction Schedule," gives details on weather conditions and construction activities during the period 14 January to 11 February 1977. The lowest temperature on a work day during this period was -14°F on 20 January. The highest temperature encountered was +46°F on January 24. Since the contractor had planned to apply roofing at temperatures as low as -25°F, no shut-downs due to temperature were required.

Table I also indicates that work was suspended on four days during this period due to snow. Specifications require that "roofing operation shall not start during periods of precipitation." Following periods of snow, some time was required for removal of snow prior to recommencement of roofing operations.

The roofing schedule indicates that vapor barrier and insulation installation took place between 14 January and 19 January, and that roofing materials were placed between 20 January and 11 February, except for weekends and those days when operations were suspended because of snow.

The roofing contractor indicated that, on this project, craftsmen were able to work between 2 and 2 1/2 hours between breaks. He indicated that "a certain breed of man" is needed to be successful in working under these conditions. Punctures to the completed roofing, due to operations conducted by iron workers, were a problem on this project. This situation is a particular problem during roofing operations in the wintertime.

The contractor also indicated that it is essential to apply all four plies in one day, rather than waiting to complete a section until the following day. This procedure is necessary to avoid entrapping moisture between plies.

TABLE I

Roofing Construction Schedule

		Temperature, °F			<u>Precipitation</u>	<u>Construction Activity</u>
		<u>Average</u>	<u>Maximum</u>	<u>Minimum</u>		
January	14	- 3	2	- 7		Place vapor barrier and insulation
	17	13	25	1		Place insulation
	18	10	19	0		Place insulation
	19	- 3	4	-10	Snow-Trace	Place insulation
	20	- 2	10	-14	Snow-Trace	Begin roofing
	21	4	11	- 4		Roofing
	24	28	46	9		Roofing
	25	22	30	14		Roofing
	26	26	32	19	Snow-3.1 in.	No work-snow
	27	26	29	23	Snow-0.1 in.	Move snow; Roofing
	28	19	23	14	Snow-Trace	Roofing
	31	- 2	0	- 3	Snow-1.4 in.	No work-snow
February	1	- 3	0	- 6	Snow-9.5 in.	No work-snow
	2	- 2	2	- 1	Snow-7.3 in.	No work-snow
	3	2	6	- 2		Move snow to completed half; Roofing
	4	11	24	- 3		Roofing
	7	7	15	- 2		Roofing
	8	8	18	- 2		Roofing
	9	1	8	- 7		Roofing
	10	4	13	- 5		Roofing
	11	- 1	9	-10	Snow-Trace	Complete job; Move out

Temperature and precipitation data from Local Climatological Data, National Weather Service Office, Fairbanks International Airport.

Coordination and cooperation between the roofing contractor and the general contractor is important in such operations, and such cooperation was a part of the Interior City Branch project.

The materials placed over the parapet walls were left until warmer weather. This heavier material is not flexible in cold weather. A temporary layer was placed during winter operations, to provide a water-tight barrier, and then the heavy permanent material was applied later in the spring.

Interior penetrations through the roof were completed, in permanent form, during winter operations. Drain installation is a particularly sensitive operation in the wintertime. At the Interior City Branch project, the approach used was to set the drains in the winter, using an excess of asphalt, and then simply tighten the drains after the winter period.

Protection of the insulated, but not yet completed, portions of the roof was provided by heavy-duty polyethylene sheeting. All materials not yet incorporated into the roof were stored in the "open" on this project and were protected by heavy-duty polyethylene. Most of this material was stored on the roof.

Approximately one-half of the roof had been completed prior to the snow storm of 31 January to 2 February. The contractor moved the snow from the uncompleted portion of the roof to the completed half, swept the uncompleted half and removed its polyethylene to make it moisture-free, and then proceeded with completion of the roofing installation.

#### ROOF PERFORMANCE

A statement regarding the performance of the roof to date is simple. In short, no problems have been encountered to date. At this writing (end of May 1978), the owner reports that the roof performed satisfactorily during the 1977-78 winter, including the spring 1978 break-up. In addition, the building, including its roof, has satisfactorily passed inspection by the City of Fairbanks Building Department.

#### SOME GENERAL COMMENTS ON ROOF CONSTRUCTION IN THE WINTERTIME

The writer was privileged to have an opportunity to interview Mr. Edwin Burbeck of Burbeck Roofing Company. Mr. Burbeck provided information on several projects that Burbeck Roofing Co. has built in the wintertime, and he then gave a large number of suggestions and cautions regarding roof construction in cold regions during the winterime (2).

The following projects have been completed successfully under wintertime conditions by Burbeck Roofing Co.:

1. 1973--Dairy Queen, Gaffney Road, Fairbanks. This roof was constructed at temperatures as low as  $-35^{\circ}$  to  $-40^{\circ}$ F.
2. 1974-75--Trainor Gate School, Fairbanks. This project went from October 1974 to January 1975, and was worked on at temperatures as low as  $-30^{\circ}$ F. From 33 to 50% more labor was required than under warm weather conditions; because the workmen were not able to move as fast, they warmed up approximately once each hour, and material had to be warmed up. An important lesson learned from this project was that all material and supplies should be gathered into one place at the completion of each day's operations, so that the materials can then be protected easily from possible snowfall.
3. 1975-76--West Valley School, Fairbanks. This wintertime project was finished at temperatures of approximately  $-25^{\circ}$  to  $-30^{\circ}$ F.
4. 1975-Tanana Medical and Surgical Clinic. This project was successfully completed during December and January.
5. 1975-76--Oil Refinery, North Pole. The roof for this project was accomplished at temperatures as low as  $-20^{\circ}$  to  $-25^{\circ}$ F.
6. 1976-77--Oil Refinery Phase II, North Pole, Alaska. The roof for this portion of the Refinery project was also applied at temperatures as low as  $-20^{\circ}$  to  $-25^{\circ}$ F.
7. 1976-77--Bentley Mall, Fairbanks. Although most of the roof was constructed at temperatures between  $+10^{\circ}$  and  $+30^{\circ}$ F, the coldest temperature during roof construction was approximately  $-10^{\circ}$ F. On the Safeway Store portion of this project, the roofing contractor provided a three-year guarantee.
8. 1976-77--Interior City Branch Bank, Fairbanks. This is the project described in the main body of this report.
9. 1977-78--Safeway Store addition, Airport Road and University Avenue, Fairbanks. Roofing was applied at temperatures as low as  $-20^{\circ}$ F.

Mr. Burbeck offered the following comments, cautions and suggestions relative to constructing roofs in the wintertime:

- Although specifications usually require that work be done at temperatures above +40°F, experience since 1973 indicates that roof applications can be accomplished at temperatures much lower than this.
- A successful sequence is the following:
  1. Insulate the entire roof.
  2. Cover the entire roof to protect it from possible snow.
  3. Complete a small area of roofing, prior to moving on to another area.
  4. If snowfall occurs, push the snow from the area to be worked on to a completed area.
- Labor costs in the wintertime increase by between one-third and one-half, because (1) the workmen move half as fast as under normal conditions, due to bulky clothing, (2) the men warm up about once every hour, and (3) efforts are required to warm roofing materials.
- Whereas normal material wastage is approximately 5%, such wastage is between 10 and 20% in cold weather.
- If the specifications call for 30 lb of asphalt per 100 ft<sup>2</sup>, one should use 35 to 40 lb per 100 ft<sup>2</sup> during cold conditions. The colder the temperature, the more asphalt should be applied.
- The most important problem encountered in roofing under cold conditions is moisture from snow, mist and fog. Snow can be a major problem, especially in roofing construction, when the temperature warms up from, say, -15°F to above 0°F. The work must always be covered up to prevent moisture intrusion.
- In order not to get moisture between plies, it is important to put all plies down at once, rather than waiting until the next day to complete the operation.
- Temporary heating should never be applied inside a building with plywood roof panels, until the complete roofing system has been completed. Otherwise, the heat from underneath the plywood will melt the snow, causing the plywood to take up moisture, which will then freeze and be trapped beneath the roofing system.

- It is extremely important to gather materials and supplies into one place at the completion of a day's operations, and to protect the material in that one place from possible snowfall.

Some material should be kept inside at night, and taken out in the morning for use. This way additional effort will not be required to warm the cold material prior to application.

- The heavy material required for parapet walls becomes so stiff in cold weather that it cannot be applied successfully in the wintertime. A successful procedure is to use a temporary material on parapet walls to make a watertight covering, and then replace this material with heavier permanent material in the springtime.
- Metal flashing should never be applied in the wintertime. Application during cold weather can lead to serious material expansion problems in warmer periods. Also, flashing at the top of walls must necessarily be applied only after completion of wall construction, which itself should be delayed until warm weather, as indicated above.
- Interior penetrations should always be installed in their final, permanent condition, in conjunction with cold weather roofing projects.
- Roof drains can pose a serious problem, due to expansion when temperatures increase. A successful approach is to set the drain in the winter, using an excess of asphalt, and then to tighten the drain the following spring after fasteners and other metal parts have expanded and asphalt has become softer.
- Roofing application inside an enclosure is generally not successful, because of lack of ventilation of toxic fumes and because mops and other tools while being used tend to strike the enclosure.
- Punctures to completed roof surfaces, from operations by other trades, are an important problem in the winter.
- A "certain breed of man" is needed to work on roof construction in the wintertime.
- Cooperation and coordination with the general contractor is essential for a successful cold weather roofing operation.

## PHOTO DOCUMENTATION

Appendix C contains several black and white photographs of the Interior City Branch bank and its roof, taken with and without snow present.

## SUMMARY AND CONCLUSIONS

This report has documented one portion of one project in a growing trend toward continuing construction projects during the wintertime. At temperatures as low as  $-14^{\circ}\text{F}$ , the roofing contractor at the Interior City Branch bank addition project applied vapor barrier, installed insulation, applied built-up roofing, installed permanent penetrations, and provided a temporary waterproof seal over the parapet wall.

Performance of the roof system, which is designed as a conventional roof like those normally constructed in warm weather, has been satisfactory to date, even though the system was built under cold weather conditions.

Contractors and owners, spurred by recent accelerating trends toward development of the north, are increasingly realizing the possible benefits of wintertime construction. Such an approach allows the utilization of otherwise idle equipment and manpower, permits receipt of contractor income sooner than if construction were delayed into the summer period, and provides project availability more quickly. The project described in this report is one small, successful example of that growing trend.

As additional information on various cold weather roofing projects is gathered, a survey that compares roofs built under cold conditions with those built in more temperate weather would be useful. Such a study might tabulate the design and construction features, costs and subsequent performance of each of several roofs in these two categories.

## LITERATURE CITED

1. Bennett, F. Lawrence. Final Report--Temporary Protection of Winter Time Building Construction, Fairbanks, Alaska. 1976-77.
2. Burbeck, E. Interview, 16 February 1978, Fairbanks, Alaska.

APPENDIX A

PROJECT SPECIFICATIONS

Section 7A--

Built-Up Roof, Roof Insulation  
and Roofing Sheet Metal

SECTION 7A

BUILT-UP ROOFING, ROOF INSULATION, AND ROOFING SHEET METAL

ROOFING GENERAL REQUIREMENTS - 7A.01

- A. APPROVED APPLICATOR: All roofing materials under this Section shall be applied by an established and qualified roofing applicator approved by the roofing materials manufacturer.
- B. GUARANTEE: The Roofing Contractor shall guarantee all roofing and roof flashing and other work installed by him which is a component part of the roofing to be watertight for a period of two years after final acceptance of the building. The Roofing Contractor agrees to make all repairs necessary to ensure a watertight roof during the entire two-year guarantee. Any damages to the building, including finish resulting from roof leaks or failure of any component part of the roof during the two-year guarantee shall be restored to its original condition by the Roofing Contractor without delay, and the entire expense will be borne by him.

The guarantee covers materials and workmanship and normal wear and tear only. It excludes damage done by others, structural damages, or acts of God.

- C. MANUFACTURER'S SPECIFICATIONS: The manufacturer's specifications for the roofing types specified herein, including specified modifications, shall be considered a part of this Section.

Complete manufacturer's specifications shall be furnished for use by the Architect's representative at the job site.

- D. LABELS, STORAGE, AND PROTECTION: All roofing materials shall be delivered in original unopened containers or wrappings and the contents clearly labeled.

Materials shall be properly handled, stored, and protected from damage in accordance with the manufacturer's printed instructions. Material damaged in a manner which would impair its intended function will be rejected and shall be removed from the job site.

SECTION 7A

BUILT-UP ROOFING, ROOF INSULATION, AND ROOFING SHEET METAL

Page 2

Upon completion of the roofing work, surplus material, waste, roofing debris, and equipment incidental to this work shall be removed from the job site.

- E. TEMPORARY ROOFING: If cold weather or otherwise normally expected unfavorable weather conditions prevail making a complete roofing system application inadvisable, and yet it is desirable to provide protection for interior finish trades to expedite work schedules, allowance shall be made to install temporary roofing protection at no additional cost to the owner.

Temporary protection may be provided by modifying the specified roofing type to a two-phase application in accordance with the roofing manufacturer's recommendations, whereby the first phase, consisting of a minimum of one layer of felt membrane over fabrics covered with a glaze coat of bitumen, shall serve as a temporary roofing, and providing that the requirements for the specified guarantee are maintained upon application of phase two and final completion of the specified roofing.

ROOFING MATERIALS - 7A.02

- A. GENERAL: Materials shall be the products of the accepted roofing manufacturer or meet the approval of the manufacturer.

Areas to receive built-up roofing shall be covered with specified membranes and smooth surface meeting the requirements for Class A, noncombustible.

Insulation, vapor barrier, and adhesive materials including application, shall meet the requirements of Factory Mutual 1-28 fire hazard and wind resistance for Class 1 insulated steel deck construction.

Where asphalt materials are specified or required, products of Johns-Manville, Flintkote, or approved equivalent are acceptable.

- B. INSULATION: Fibrous-glass type, 3 x 4-foot, rigid non-combustible boards composed of inorganic glass fibers, conforming to Federal Specification HH-I-526C; same as Owens-Corning Fiberglas Corporation's Roof Insulation; two layers having a combined C factor of both layers not to exceed 0.12.

SECTION 7A

BUILT-UP ROOFING, ROOF INSULATION, AND ROOFING SHEET METAL

Page 3

C. FELTS AND FABRIC

1. Vapor Barrier Over Metal Deck: Sisalkraft, 298 Vaporstop.
2. Roof Tape: 6-inch-wide glass fiber reinforced, Owens-Corning Fiberglas Roof Tape.
3. Asphalt-Saturated Asbestos Felt: ASTM D 250-68, No. 15, perforated.
4. Bituminous Woven Glass Fabric: ASTM D 1668-63.

D. ADHESIVE VAPOR BARRIER TO METAL DECK: Sisalkraft, Pyro-Kure adhesive.

E. BITUMENS

1. Steep Asphalt: ASTM D 312-64, softening point not less than 185 degrees F.
2. Asphalt for Roofing Plies and Surfacing: Johns-Manville Aquadam, meeting ASTM D 312-64, softening point as recommended by roofing manufacturer.

F. PLASTIC CEMENT: Asphalt type, FS SS-C-153, Type I.

G. INSULATION FASTENING SCREWS: Type as recommended and listed by Factory Mutual in loss prevention data sheet 1-28, latest edition.

H. ACCESSORIES: As recommended by approved roofing manufacturer.

I. CANTS: Impregnated fiberboard.

INSPECTION AND PREPARATION OF SURFACES - 7A.03

Prior to starting the work, inspect all surfaces to be covered. Defects in workmanship and materials of other trades that may affect the finished work of this Section shall be corrected before work starts. The starting of work on any surface shall imply that the surface has been inspected and approved by the applicator.

SECTION 7A

BUILT-UP ROOFING, ROOF INSULATION AND ROOFING SHEET METAL

Page 4

The laying of vapor barrier, insulation, or roofing shall not start until substrate is smooth, firm, dry, free from dirt, foreign materials, sharp projections or voids, and has been inspected and approved.

Vents, curbs, and other projections through roofs shall be properly installed, flashed, and secured in position.

ROOFING APPLICATION - 7A.04

- A. GENERAL: Roofing membranes, base flashing, and accessories shall be applied or installed in accordance with their manufacturer's printed specifications and with specified modifications.

Vapor barrier and insulation shall be applied in accordance with Factory Mutual data sheet 1-28.

The work and materials of other trades shall be adequately protected from damage by asphalt drippings, splatter, or any roofing operation. Any such damage shall immediately be repaired to the Architect's satisfaction, at no expense to the Owner.

Roofing operations shall not start during periods of precipitation. If, during roofing operations, precipitation begins, work shall immediately be stopped, all unroofed insulation protected against the intrusion of moisture, and membrane edges sealed.

The construction of any bay or section of roof deck surface shall be completed and inspected before roofing work is begun.

- B. VAPOR BARRIER: Lay vapor barrier under all insulation, overlap 2 inches minimum on sides and ends, and seal with adhesive.

Embed vapor barrier in full (solid) coating, not strip application, of adhesive. The use of full embedment, besides adhering the vapor barrier to the metal deck, is to fill any void in the vapor barrier with adhesive where the insulation holding screws pass through the membrane.

- C. ROOF INSULATION

1. Applications: Secure first layer of insulation with specified screws. Determine exact quantity and spacing pattern in accordance with Factory Mutual 1-28.

SECTION 7A

BUILT-UP ROOFING, ROOF INSULATION AND ROOFING SHEET METAL

Page 5

Apply second layer over first in full (solid) mopping of hot-steep asphalt, applied at the rate of 30 pounds per 100 square feet. Press insulation firmly into hot asphalt. Break joints of second layer a minimum of 4 inches with those of the first layer and apply roof tape to top joints per manufacturer's recommendations.

Cut roof insulation to fit neatly around all roof projections.

2. Water Cutoffs: Provide water cutoffs at end of day's work and whenever precipitation is imminent.
  - a. Water cutoffs shall be applied to exposed edges of roof insulation, extended 6 inches on roof deck, carried up and over roof insulation, and extended 6 inches on top of built-up roofing.
  - b. Remove water cutoffs before continuing with the installation of the roof insulation and built-up roofing.
3. Protection of Roof Insulation: Do not leave installed glass fiber insulation exposed to the weather. Lay no more roof insulation than will be completely covered with complete built-up roofing on the same day.

- D. BUILT-UP ROOFING shall be Johns-Manville, Specification 153-P, or approved equivalent, modified to include two solid-mopped layers of Duramesh woven glass fabric under asbestos felts.

Finish in one operation the application of built-up roofing up to the line of termination at end of day's work. Any portion of the roof system left exposed without final surfacing must be removed before proceeding with the permanent installation.

All roof areas shall be accurately laid out for proper lap and sequence of plies, and all plies laid shingle fashion with proper exposure. Each ply shall be broomed in place while the bitumen is hot and tacky, and felts shall be free from fishmouths, buckles, blisters, or other faulty workmanship.

E. ACCESSORIES CONSTRUCTION

1. Lead Collars at Roof Drains: Extend flat sheet from inside edge of drain to minimum of 4 inches outside of clamping ring. Place between plies of felt and flash watertight.
2. Vent Pipe Flashing: Embed flanges in asphalt over the first layer of membrane with additional reinforcing plies.

SECTION 7A  
BUILT-UP ROOFING, ROOF INSULATION AND ROOFING SHEET METAL  
Page 6

After all roofing plies are in place, form a plastic cement cant around base.

ROOFING SHEET METAL - 7A.05

- A. GENERAL: Gauges, weights, and thicknesses shall be as specified unless noted otherwise on the Drawings.

Exterior copings adjacent to metal-clad fascia panels are specified to be fabricated under Section 7J and to be furnished to the Contractor under this Section 7A for installation.

B. MATERIALS

1. Aluminum: Alcoa Aluminum Flat Industrial Flashing Sheet or approved equivalent with a mill finish.

Minimum gauges for face dimensions shall be maximum 4- and 5-inch face 0.032 inch, 6- and 7-inch face 0.040-inch, and 8-inch face and over 0.050-inch.

2. Screws, bolts, and miscellaneous accessories for fastening materials shall be of similar type metals.

FABRICATION AND INSTALLATION -7B.06

- A. METAL FLASHING NOT FURNISHED BY OTHERS: Fabrication and erection shall conform to the Architectural Sheet Metal Manual of the Sheet Metal and Air Conditioning Contractors National Association, Inc. .

Accurately form to the dimensions and shapes as detailed on the Drawings. Members shall finish with true, straight, and sharp lines and angles; and where intercepting each other, shall be coped to an accurate fit and securely fastened. All exposed edges of sheet metal work shall be turned back 1/2-inch unless otherwise indicated.

Exterior sheet metal work shall be watertight and shall be formed, fabricated, and installed to adequately provide for expansion and contraction in the completed work.

Flashing laps shall be set in specified plastic cement, with the cement held back 1/2-inch from the joint.

SECTION 7A

BUILT-UP ROOFING, ROOF INSULATION AND ROOFING SHEET METAL

Page 7

Sheet metal work shall be calked and sealed with approved compounds and as required for a completely watertight installation. Where no ed sealant on the Drawings, seal as specified under Section 7C.

Where metal work comes in contact with a dissimilar metal or material, it shall be primed with Bituplastic 28 primer and painted with one heavy brush coat of Bituplastic 28.

Provide all necessary covers, clips, and anchors as required to complete the work.

Straight runs shall be in maximum lengths with minimum number of joints.

Factory-manufactured items shall be installed in accordance with the manufacturer's recommendations.

- B. COPING FLASHING FURNISHED UNDER SECTION 7J: Install coping flashing furnished under Section 7J.

Avoid damage and abrasion of finished surfaces of the material.

Install flashing in accordance with the supplier's recommendations for a complete watertight installation.

MISCELLANEOUS SHEET METAL WORK - 7B.07

Sheet metal work not specifically mentioned in this Section and not normally furnished by other trades shall be provided as indicated on the Drawings or required to complete the project.

SUPPLEMENTARY SPECIFICATIONS  
FOR  
FIRST NATIONAL BANK OF ANCHORAGE  
  
INTERIOR CITY BRANCH  
  
Fairbanks, Alaska

Prepared By  
JOHN GRAHAM COMPANY  
Architects - Planners - Engineers  
Anchorage  
August 20, 1976

---

The following Supplementary Specifications are in addition to and shall become a part of Specification for First National Bank of Anchorage, Interior City Branch, dated September 22, 1972, and shall be incorporated in and become a part of the above Specification as though fully set forth therein. Where materials, workmanship, equipment, erection and application methods required to complete the work as indicated on the Drawings are specified in the original Specification, they will not be repeated in this Supplementary Specification.

Section and Item numbers listed herein are for reference to the same component Section and Item Numbers of the First National Bank of Anchorage, Interior City Branch Specification.

Certain Sections, whole or in part, of the original Specification are not required for completion of this work and shall be considered as not applicable.

2. Add the following item:

" FIRE-RETARDANT-TREATED PLYWOOD

Where fire-retardant-treated plywood is shown or scheduled, comply with AWPI Specification C-20B for pressure impregnation with fire-retardant chemicals to achieve a flame spread rating of not more than 25 when tested in accordance with UL Test 723, ASTM E 84, or NFPA Test 355.

Coat surfaces cut after treatment with a heavy brush coat of the same fire-retardant chemical.

Provide UL label on each piece of fire-retardant-treated plywood. "

L. SECTION 7A - BUILT UP ROOFING, ROOF INSULATION, AND ROOFING SHEET METAL

1. Item 7A.02-B, Insulation, page 3: Change the last two lines to read:

" Two layers having a combined C factor of both layers not to exceed 0.06. "

2. Add the following item:

" REMOVAL OF EXISTING ROOF SYSTEM - 7B.08

Remove the existing roof system, within the limits indicated on the drawings, including roofing, insulation and vapor barrier. Also, remove the vapor barrier adhesive down to bare metal on the steel roof deck; this is required to assure a bond between concrete and deck when the new floor is poured. "

- M. Add new section:

"

SECTION 7F

SURFACE MEMBRANE

GENERAL REQUIREMENTS - 7F.01

- A. APPLICATOR: The applicator shall be qualified and approved by the material manufacturer.

APPENDIX B. DETAILS SHOWING ROOFING DESIGN

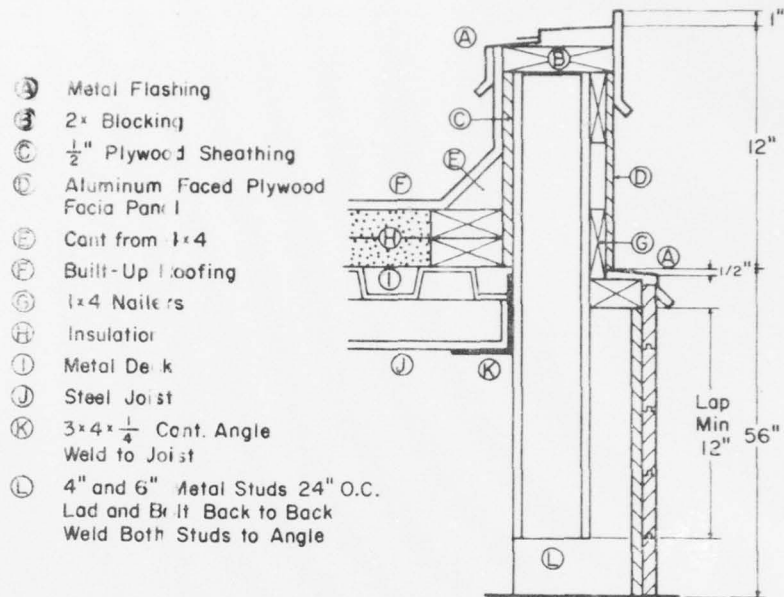

Fig. B1. Roof parapet detail

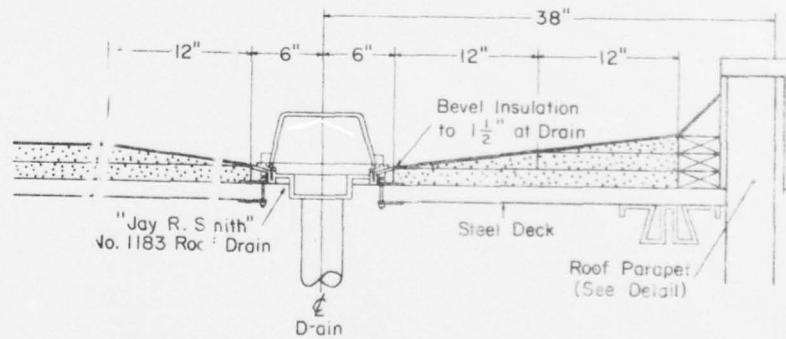

Fig. B2. Roof drain detail

APPENDIX C

Photographs

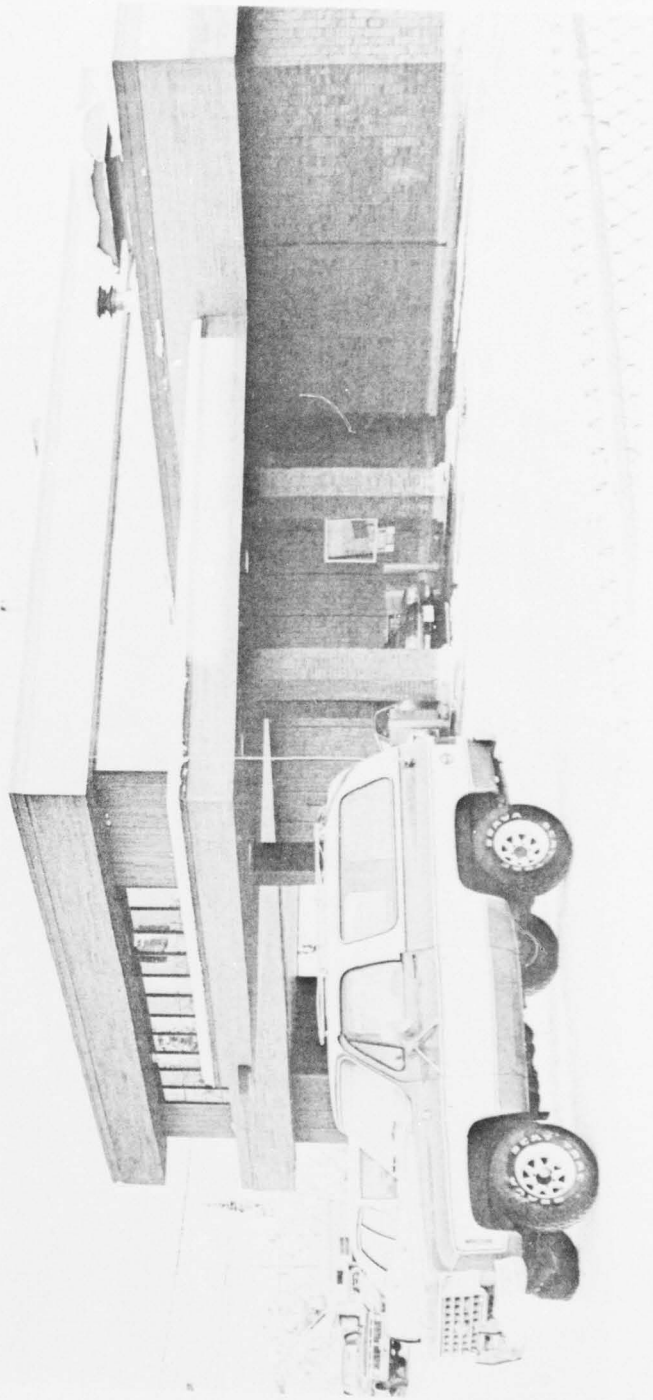

Figure C1. View of Addition Portion of Building, Looking Northeast,  
20 January 1978



Figure C2. General View of Addition Portion of Building, Looking West,  
20 January 1978.

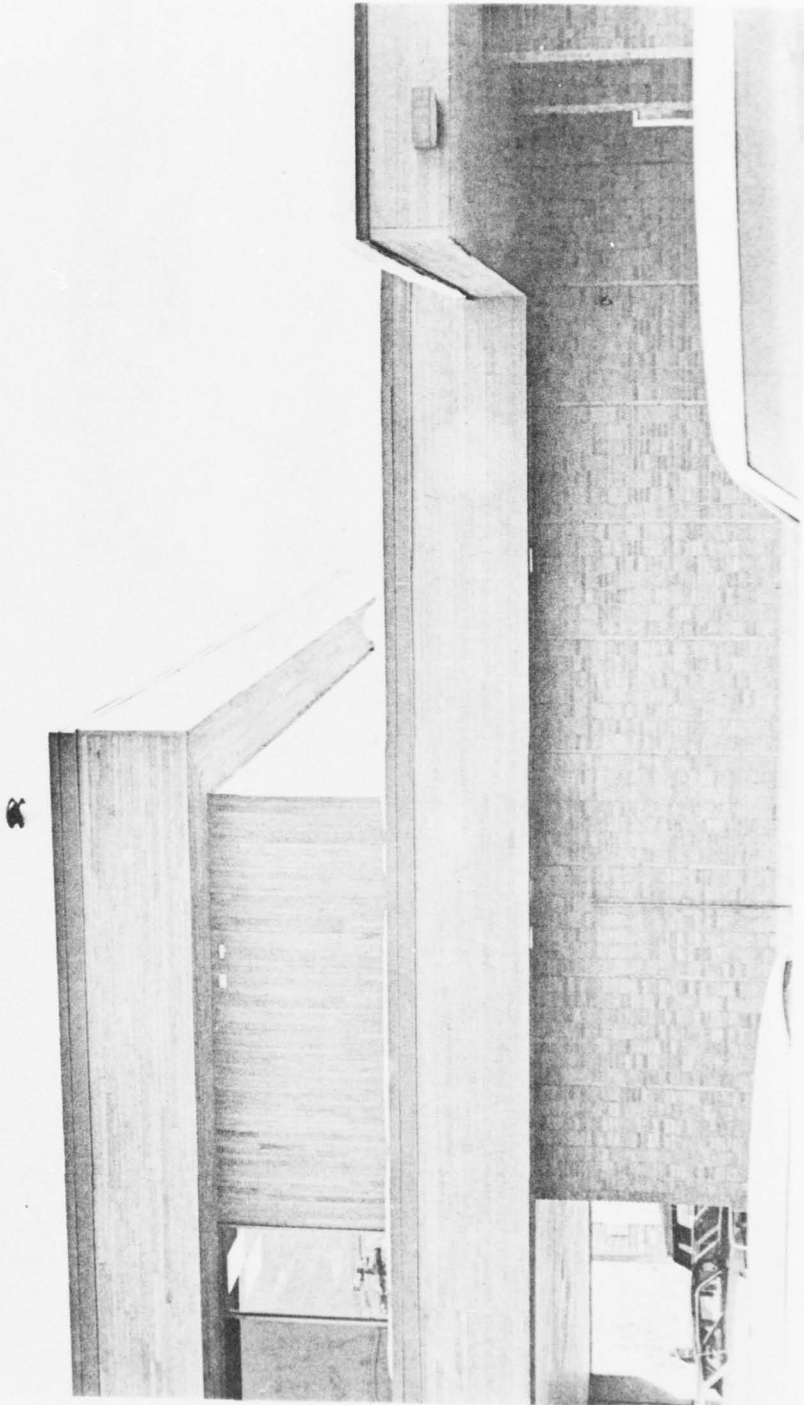

Figure C3. View of Area Between Old Section (right) and New, Higher Section (left), Looking East, 20 January 1978.



Figure C4. Roof Drain at Breakup Time, 7 April 1978.



Figure C5. Roof Ventilator at Breakup Time, 7 April 1978.

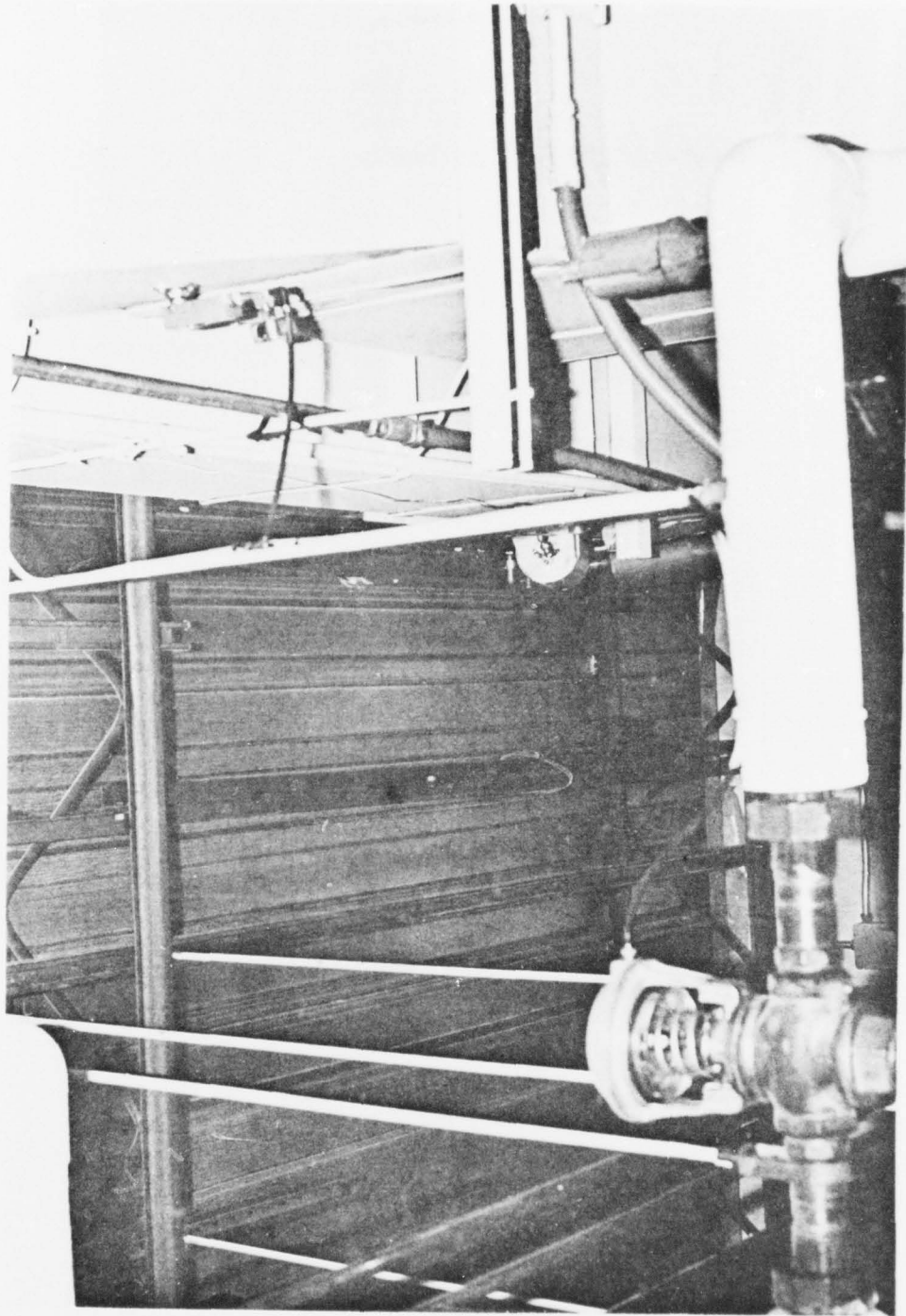

Figure C6. Underside of Roof Deck in Furnace Room, 7 April 1978.

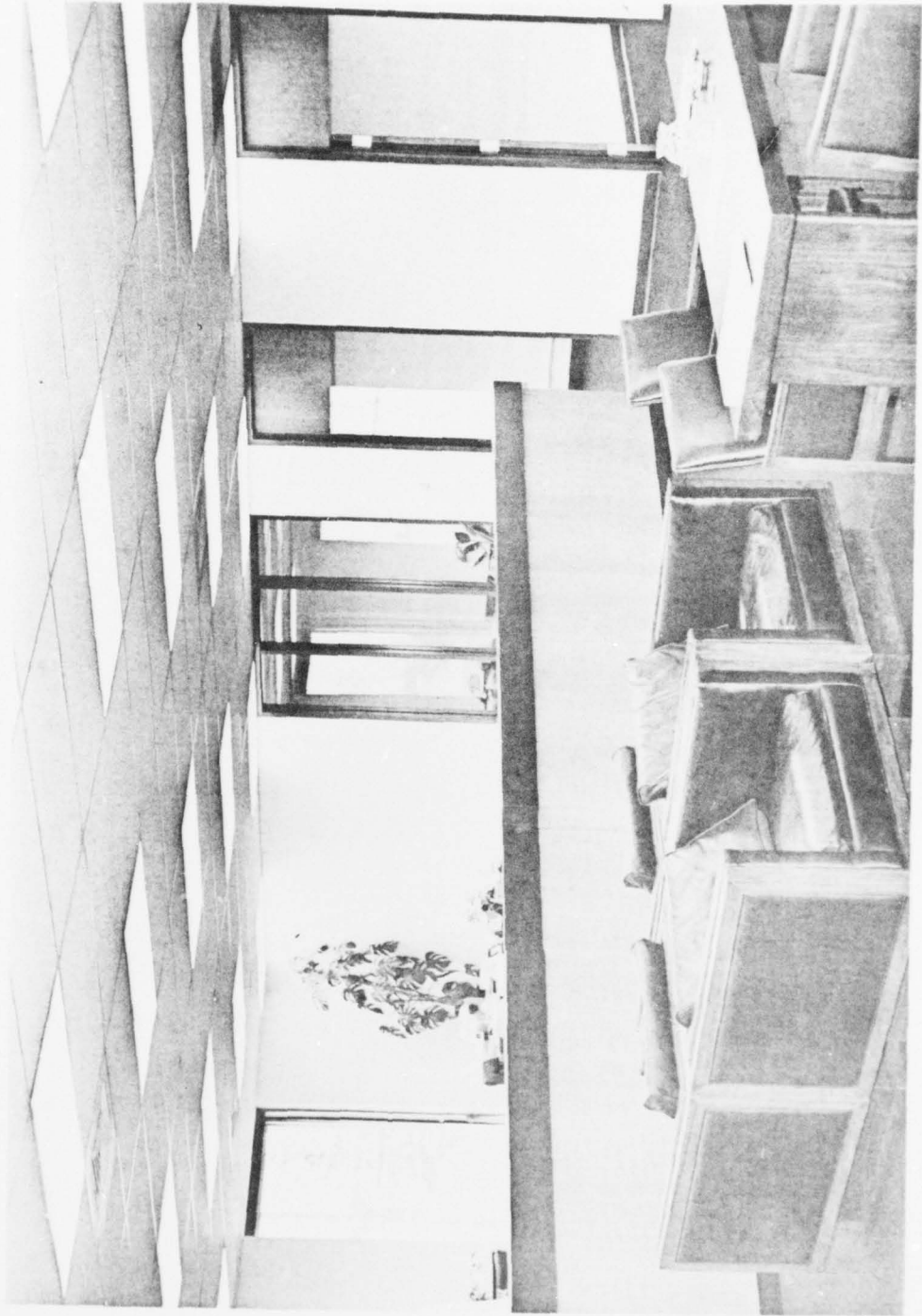

Figure C7. Interior of Addition Portion of Building, 7 April 1978.



Figure C8. General View of Addition Portion of Building, Looking Northeast  
11 May 1978.



Figure C9. Parapet Wall, Looking North, 11 May 1978.

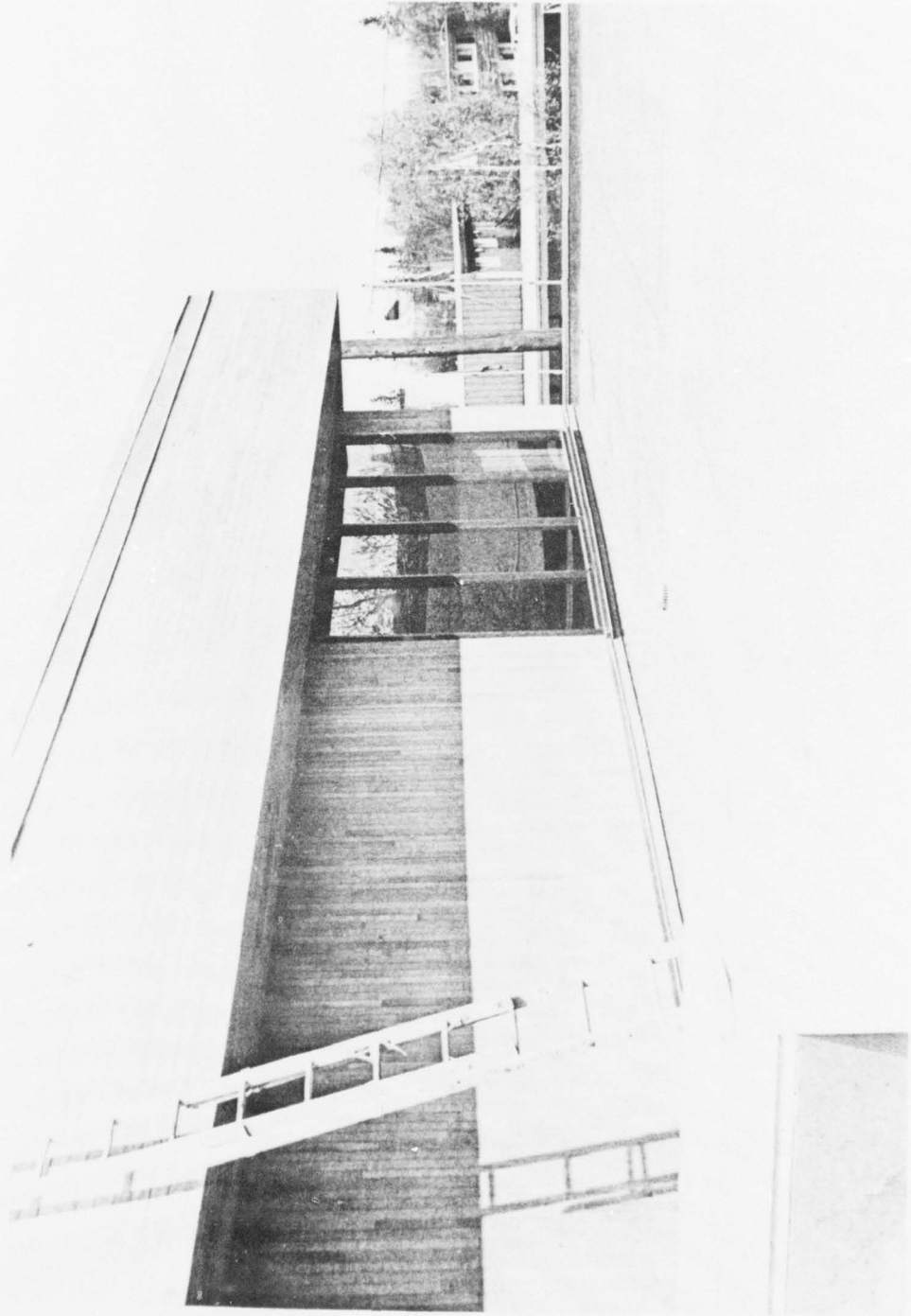

Figure C10. Addition Portion of Building, From Old Roof, Looking Northeast, 11 May 1978.

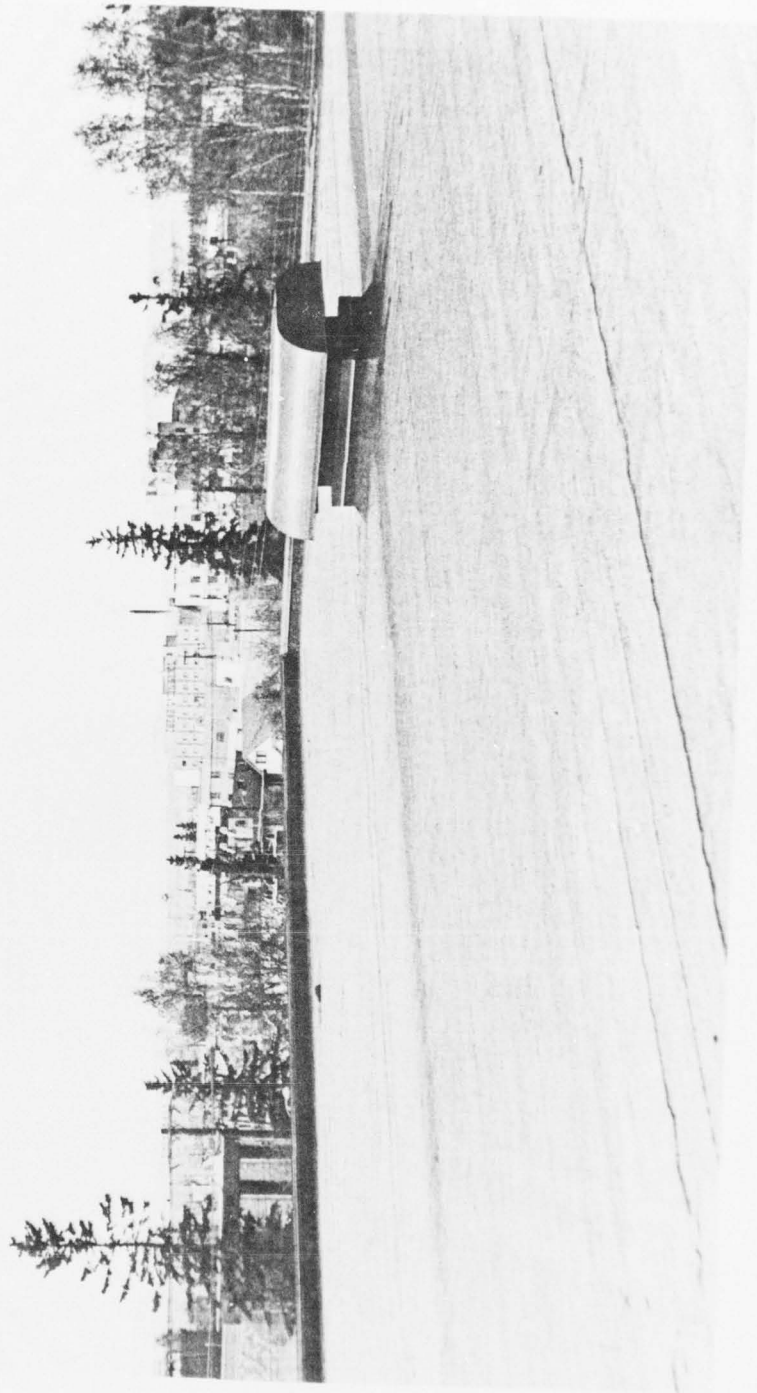

Figure C11. View Looking Northwest Across Roof, 11 May 1978.

