

AD-A062 653

CONSTRUCTION ENGINEERING RESEARCH LAB (ARMY) CHAMPAI--ETC F/G 13/2  
TECHNICAL EVALUATION STUDY: ENGERY RECOVERY FROM SOLID WASTE AT--ETC(U)  
OCT 78 A N COLLISHAW, S A HATHAWAY

UNCLASSIFIED

CERL-TR-E-136

NL

1 OF 1  
ADA  
062653



END  
DATE  
FILMED  
3 -79  
DDC

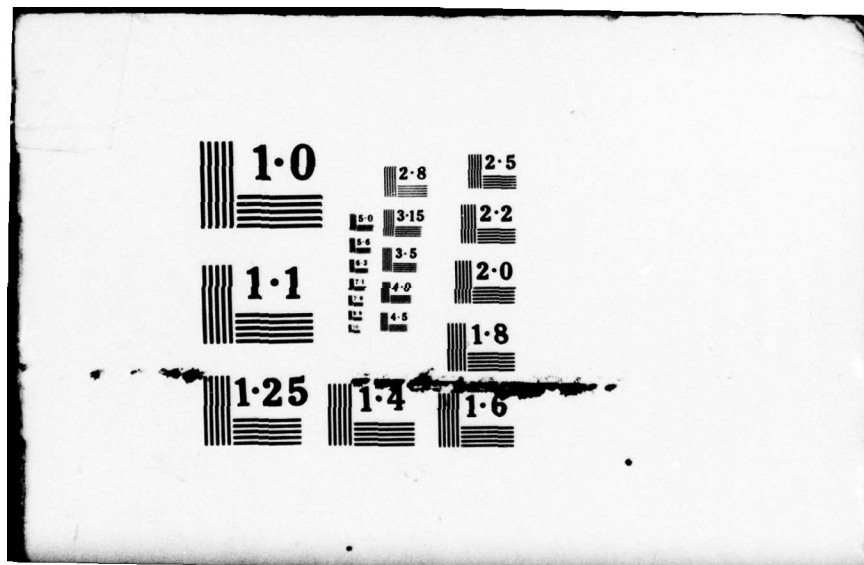

1.0

2.8

2.5

3.15

2.2

1.1

3.5

2.0

4.0

4.5

1.8

1.25

1.4

1.6

construction  
engineering  
research  
laboratory

12

TECHNICAL REPORT E-136  
October 1978

TECHNICAL EVALUATION STUDY:  
ENERGY RECOVERY FROM SOLID WASTE  
AT FORT DIX, NJ  
AND NEARBY CIVILIAN COMMUNITIES

LEVEL II

by  
A.N. Collishaw  
S.A. Hathaway

DDC  
REPRODUCED  
DEC 29 1978  
RESOLVED  
F

AD A0 62 653

DDC FILE COPY

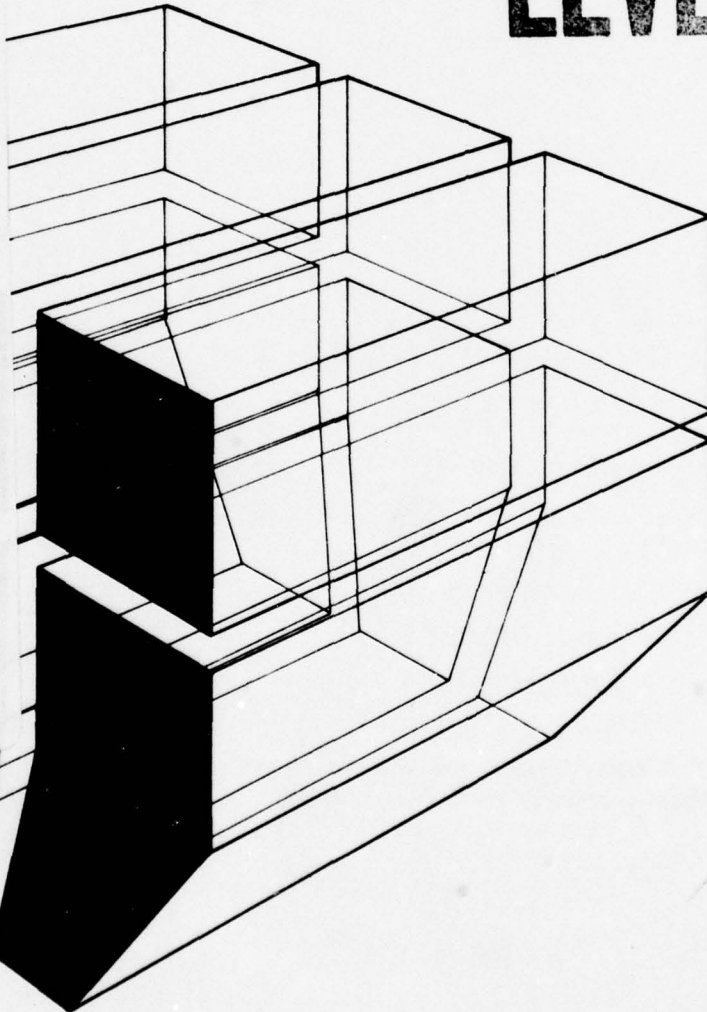

UW  
ERL

78 12 26 104  
Approved for public release; distribution unlimited.

The contents of this report are not to be used for advertising, publication, or promotional purposes. Citation of trade names does not constitute an official indorsement or approval of the use of such commercial products. The findings of this report are not to be construed as an official Department of the Army position, unless so designated by other authorized documents.

***DESTROY THIS REPORT WHEN IT IS NO LONGER NEEDED  
DO NOT RETURN IT TO THE ORIGINATOR***

REPORT DOCUMENTATION PAGE		READ INSTRUCTIONS BEFORE COMPLETING FORM
1. REPORT NUMBER 14 CERL-TR-E-136	2. GOVT ACCESSION NO.	3. RECIPIENT'S CATALOG NUMBER 9
4. TITLE (and Subtitle) 6 TECHNICAL EVALUATION STUDY: ENERGY RECOVERY FROM SOLID WASTE AT FORT DIX, NJ AND NEARBY CIVILIAN COMMUNITIES,	5. TYPE OF REPORT & PERIOD COVERED FINAL rept's	
7. AUTHOR(s) 10 A. N. Collishaw S. A. Hathaway	6. PERFORMING ORG. REPORT NUMBER	
9. PERFORMING ORGANIZATION NAME AND ADDRESS CONSTRUCTION ENGINEERING RESEARCH LABORATORY P.O. Box 4005 Champaign, IL 61820	8. CONTRACT OR GRANT NUMBER(s)	
11. CONTROLLING OFFICE NAME AND ADDRESS	10. PROGRAM ELEMENT, PROJECT, TASK AREA & WORK UNIT NUMBERS IAO SO-79-76	12. REPORT DATE 11 October 1978
14. MONITORING AGENCY NAME & ADDRESS (if different from Controlling Office) 1257 P.	13. NUMBER OF PAGES 52	15. SECURITY CLASS. (of this report) Unclassified
16. DISTRIBUTION STATEMENT (of this Report) Approved for public release; distribution unlimited.		
17. DISTRIBUTION STATEMENT (of the abstract entered in Block 20, if different from Report)		
18. SUPPLEMENTARY NOTES Copies are obtainable from National Technical Information Service Springfield, VA 22151		
19. KEY WORDS (Continue on reverse side if necessary and identify by block number) energy recovery solid waste savings/investment ratio		
20. ABSTRACT (Continue on reverse side if necessary and identify by block number) This study investigated the technical and economic feasibility of energy and materials recovery from solid waste presently landfilled at Fort Dix, NJ. The waste stream consists of conventional mixed solid waste generated at Fort Dix and adjacent McGuire Air Force Base (AFB). The available energy content of the waste stream is approximately $21.4 \times 10^{10}$ Btu/year from 18,600 tons/year mixed solid waste. Combining civilian waste from nearby communities with the military waste stream was considered. A total of 73,900 tons/year could be processed and the heat energy utilized.		

DD FORM 1473  
1 JAN 73

EDITION OF 1 NOV 65 IS OBSOLETE

78 12 UNCLASSIFIED 104

405279 SECURITY CLASSIFICATION OF THIS PAGE (When Data Entered)

Block 20 continued.

Using solid waste from both military installations alone, commercially available package controlled-air incinerators with energy-recovery boilers are the most cost-effective alternative. This alternative has a savings/investment ratio (SIR) of 4.36/1.00, requires a capital investment in FY80 dollars of \$2.75 million, and conserves 1.05 million gal of fuel oil each year. The time required to pay back the investment is 4.7 years. The energy to cost ratio is 57.3 million Btu saved annually per \$1000 invested.

Using civilian together with military waste requires field-erected incinerator-boilers with a capital investment of \$13.1 million. This alternative has an SIR of 3.60/1.00 and a payback period of 5.0 years. The amount of fuel oil conserved is 3.73 million gal each year. The energy to cost ratio is 42.7 million Btu saved annually per \$1000 invested.

Continuing the present practice of landfilling at Fort Dix is environmentally and technically sound, but would involve cost instead of savings, and would have no fuel conservation benefits.

ADDITIONAL FOR

NTIS

DDC

UNCLASSIFIED

JUS

---

BY

DISSEMINATION AND CONTROL

CHAL

A

UNCLASSIFIED

## SUMMARY

### Objective

The objective of the study conducted under Intra-Army Order S079-76 was to assess the technical and economic feasibility of recovering energy and materials from solid waste generated at Fort Dix (including adjacent McGuire Air Force Base [AFB]). In accordance with recent DOD guidelines,<sup>1</sup> the feasibility of using solid waste generated in the surrounding civilian area as an energy resource at Fort Dix was also investigated.

### Solid Waste Generation

The study indicated that approximately 60 tons/day (6 days/week basis) of solid waste is generated within the Fort Dix and McGuire AFB complex. Fort Dix generates 34 tons/day, and McGuire AFB 26 tons/day. The waste energy generation rate of the total waste stream is 214,000 MBtu/year.

The area immediately surrounding Fort Dix is largely residential, with Mount Holly, 10 miles west, being the largest local city, with a population of 14,000.

### Regionalization

It was found that approximately 190 tons/day of waste generated in the surrounding civilian area could be made available to Fort Dix as an energy resource.

### Current Waste Disposal Operations

Solid waste generated at Fort Dix and McGuire AFB is collected and hauled by a private contractor to a sanitary landfill located at Fort Dix. The landfill is environmentally sound and has an indeterminate functional life. Other area is available at Fort Dix for landfilling when the current facility becomes depleted.

### Energy-Recovery Alternatives

#### General

Two energy-recovery alternatives were evaluated using military waste only (Fort Dix and McGuire AFB). In addition, two alternatives were evaluated using military and civilian waste as an energy resource. In the regional (military-civilian) alternatives, certain limitations were placed on the nature of civilian waste delivered to Fort Dix. These limitations required delivery of combustible waste material devoid of adverse materials such as oversized bulky incombustibles (e. g., white goods), explosives and other highly volatile wastes, toxic substances, and pathological waste. In essence, delivered material from the civilian areas would be a pretreated (by separation) refuse-derived fuel.

#### Technology

Of the four alternatives evaluated, one employs modular (package) heat recovery incinerators, while three use site-erected waterwall furnaces. The modular incinerator system is the controlled air type, a horizontal cylindrical stationary bed furnace with semi-continuous ram feeding and positive displacement ash removal. The recommended configuration is the piggyback dual chamber; combustion is at less than theoretical air in the primary chamber, with complete burnout achieved in excess air environment in the secondary chamber. Off-gases enter a package watertube boiler for steam generation, pass through air pollution control equipment, and are vented to the atmosphere. Delivered waste is handled by the front-end loader/tipping floor method. Quenched ash is containerized for regular removal to landfill.

---

<sup>1</sup> *Solid Waste Management Collection, Disposal, Resource Recovery, and Recycling Program*, Department of Defense (DOD) Directive 4165.60 (October 1976).

In the alternatives using the waterwall furnace, initial handling of waste is by front-end loader. The material is fired on a double reciprocating grate stoker. Quenched ash is containerized for regular removal to landfill.

For all alternatives, the recommended plant location is adjacent to existing Boiler Plant 5881. Steam is distributed to the existing main header, and condensate is returned to the waste heat plant. Operation is three shifts/day, 6 days/week, allowing a seventh day for maintenance and peak load processing. Equipment redundancy is included in the most cost-effective alternative.

*Economic Analysis*

In accordance with AR 11-28 (December 1975), the present value (PV) method of economic analysis was used. Short-term and long-term differential escalation rates used are shown in Table A. A discount rate of 10 percent was employed. The analyses were carried out for a project economic life of 25 years (FY81 through FY06). Table B summarizes the economic analyses of alternative resource-recovery systems. Economic analyses which result in a Savings to Investment Ratio (SIR) greater than 1.0 are, by definition, cost effective.

*Alternative A: Continue Present Practice*

This is the baseline alternative against which the costs and benefits of resource-recovery alternatives were compared. Presently used and potential landfill facilities at Fort Dix are adequate to accommodate future waste generation over the long term. This alternative requires no major capital investment. Waste collection and hauling are by contractor, with disposal in the on-post Army-operated landfill. The 25-year PV cost of this alternative is \$5,740,000, including contracts and landfill operation. There are no resource-recovery aspects to this alternative.

*Alternative B: Military Waste, Modular Incinerators*

This alternative includes five modular incinerator-boiler systems, of which four are in continuous parallel operation and the fifth is available as backup. Steam production is 21,000 lb/hr. An investment of \$2,750,000 is required. Approximately 1,050,000 gal/year fuel oil would be conserved. Compared to the baseline alternative (A), this system has an SIR of 4.3 and a corresponding payback period of 4.7 years. (See Table B).

**Table A**  
**Basis of Economic Analysis**

**Date of Estimate: June 1977**  
**First Year of Project Operation: FY81**  
**Length of Economic Life: 25 years**  
**Midpoint of Construction: June 1980**

Annual Cost Element	Unit Cost	Short-Term Escalation Rates (%/yr)				Long-Term (25-yr) Differential Escalation Rate (%)*
		FY78	FY79	FY80	FY81	
Construction	--	8.0	8.0	8.0	NA	0
Labor	--	7.0	6.6	6.5	6.5	0
Materials	--	7.0	6.6	6.5	6.5	0
Maintenance	5% of cap	7.0	6.6	6.5	6.5	0
Fuel Oil	\$0.36/gal	16.0	16.0	16.0	16.0	8.0
Electricity	\$0.026/kWh	16.0	16.0	16.0	16.0	7.0
Water	\$0.50/kgal	5.0	5.0	5.0	5.0	0
Reclaimed Ferrous	\$26.70/ton	5.0	5.0	5.0	5.0	0
Vehicle Fuel	\$0.55/gal	16.0	16.0	16.0	16.0	8.0

\*Differential rate of 0% indicates cost escalates according to average national inflation

**Table B**  
**Summary of Energy-Recovery Alternatives**

Alternative	Tons/yr Processed	Operating Steam Capacity (lb/hr)	Percent of FY76 Post Heating Load	Capital Investment (\$)	SIR	Years to Payback	Energy-to-Cost Ratio *
A	18,600	-	-	-	-	-	-
B	18,600	21,000	9.7	2,750,000	4.36	4.7	57.3
C	18,600	21,000	10.0	2,950,000	3.95	5.3	55.9
D	52,100	50,000	21.0	9,790,000	2.84	6.5	35.2
E	73,900	75,000	35.0	13,100,000	3.60	5.0	42.7

\*Note: The energy-to-cost ratio is the annual energy savings in Btu per \$1000 invested in the alternative.

*Alternative C: Military Waste, Site-Erected Incinerator*

This alternative includes a site-erected waterwall incinerator to fire as-received solid waste generated at Fort Dix and McGuire AFB. Steam production is 21,000 lb/hr. Approximately 1,100,000 gal/year fuel oil would be conserved. Compared to the baseline alternative (A), this system has an SIR of 3.95 and a corresponding payback period of 5.3 years. (See Table B.)

*Alternative D: Regional Waste, Site-Erected Incinerator With Ferrous Metals Preseparation, I*

This alternative includes three site-erected waterwall incinerators firing coarse-shredded, ferrous-depleted solid waste. Material received both from Fort Dix and McGuire AFB and the civilian community (on demand to meet steaming requirements) passes through a shredder (vertical shaft hammermill) and magnetic separator for extraction of ferrous metals. Mass processing rate is 52,100 tons/year. Steam production is 50,000 lb/hr, which is greater than the load on Boiler Plant 5881. A new steam line with condensate return is installed to connect the Boiler Plant 5881 distribution system to Boiler Plant 5252 (hospital boiler plant), allowing its shutdown for most of the year. The required investment for this system is \$9,790,000. Annual fuel oil savings total 2,300,000 gal. Compared to the baseline alternative (A), this system has an SIR of 2.84 and a corresponding payback period of 6.5 years. (See Table B.)

*Alternative E: Regional Waste, Site-Erected Incinerator With Ferrous Metals Preseparation, II*

Technology under this alternative includes three site-erected waterwall incinerators to fire coarse-shredded, ferrous-depleted solid waste. Material received both from Fort Dix and McGuire AFB and the civilian community (on demand to meet steaming requirements) passes through a shredder (vertical shaft hammermill) and magnetic separator for extraction of ferrous metals. Mass processing rate is 73,900 tons/year. Steam production is 75,000 lb/hr, which is greater than the load on Boiler Plant 5881. A new steam line with condensate return connects the distribution systems of Boiler Plants 5881 and 5426, the second major heating plant on the post. The required investment for this system is \$13,100,000. Annual fuel oil savings total 3,730,000 gal. Compared to the baseline alternative (A), this system has an SIR of 3.6 and a corresponding payback period of 5.0 years. (See Table B.)

**Conclusions**

The study indicated that it is technically feasible to recover energy from solid waste at Fort Dix and McGuire AFB, as shown by Alternatives B and C. Metals and energy recovery from incineration of civilian and military wastes are technically and economically feasible, as shown by Alternatives D and E.

Alternative B is the most cost-effective, is the least-investment energy-recovery alternative, will save 1,050,000 gal/year fuel oil, and requires a capital investment of \$2,750,000. Its payback period is 4.7 years. The energy-to-cost ratio is 57.3.

Alternative C is the second most cost-effective energy-recovery alternative; the energy-to-cost ratio is 55.9.

Alternative E is cost-effective and the most fuel-conservative energy-recovery alternative; it will save 3,730,000 gal/year fuel oil. It requires a capital investment of \$13,100,000 and has a payback period of 5.0 years. The energy-to-cost ratio is 42.7.

Continuation of landfilling Fort Dix and McGuire AFB wastes at the Fort Dix landfill (Alternative A) is acceptable; however, it is the least cost-effective alternative, and does not provide for energy conservation.

The break-even point for a shredder for construction demolition lumber is 416 tons/year for Alternatives B and C. Shredders are required as part of Alternatives D and E.

Data from the weigh survey and national average waste characterization were sufficient for the economic analysis, but are not adequate for engineering design calculations.

Incinerator residue is not acceptable for use as road construction material.

#### **Recommendations**

Fort Dix should construct a resource-recovery facility—either the least-investment alternative (Alternative B) or the most fuel-conservative energy-recovery alternative (Alternative E), and achieve payback in less than 5 years. It is therefore recommended that Fort Dix prioritize fuel savings vs project cost and implement the energy-recovery system which best responds to these priorities.

Incombustibles such as concrete, sand, steel from construction demolition, and oversized bulky items, "self-help" disposals, and incinerator residue should continue to be at landfilled Fort Dix.

Metal recycling should only be incorporated in Alternative E, energy-recovery incinerator plant operations, because it would not be cost effective in the other alternatives.

If either Alternative B or C is funded, investigations should be undertaken to determine site-specific design data (i.e., tons of waste/day and heating value of the waste) and whether sufficient construction/demolition lumber will be available to make incorporation of a shredder cost effective.

If Alternative E is selected, a formal agreement should be made with the civilian solid waste management representatives to assure delivery of appropriate quantities and quality of solid waste.

## FOREWORD

This study was performed by the Energy Branch (EPE), Energy and Power Division (EP), U.S. Army Construction Engineering Research Laboratory (CERL). The work was performed for the Environmental Office, Directorate of Facilities Engineering, Fort Dix, NJ, under Intra-Army Order SO-79-76. The Project Engineers at Fort Dix were Mr. E. Kaeufer and Mr. J. Haug. Mr. S.A. Hathaway was the CERL Principal Investigator.

The timely assistance of CPT R. Brown, Mr. A. Brogan, and Mr. K. Hastings of Fort Dix is acknowledged. Support provided by Dr. D.J. Leverenz, Chief of EPE, and Mr. R.G. Donaghy, Chief of EP, is also acknowledged.

COL J.E. Hays is Commander and Director of CERL, and Dr. L.R. Shaffer is Technical Director.

## CONTENTS

<b>DD FORM 1473</b>	<b>2</b>
<b>SUMMARY</b>	<b>3</b>
<b>FOREWORD</b>	<b>7</b>
<b>LIST OF TABLES AND FIGURES</b>	<b>9</b>
<b>1 INTRODUCTION .....</b>	<b>11</b>
Background	
Objective	
Approach and Scope	
<b>2 BASIS FOR SYSTEM EVALUATION .....</b>	<b>11</b>
Characterization of Solid Waste	
Current Solid Waste Management Practice	
Steam Production Capabilities at Fort Dix	
Sale Potential of Recyclable Materials	
<b>3 DESCRIPTION OF SOLID WASTE MANAGEMENT ALTERNATIVES .....</b>	<b>16</b>
Nonenergy-Recovery System: Continuation of Present Practice (Alternative A)	
Package Incinerator/Boiler Energy-Recovery Systems:	
Combined Fort Dix and McGuire AFB Waste Streams (Alternative B)	
Field-Erected Incinerator/Boiler Energy-Recovery System (Alternative C)	
Resource Recovery From Solid Waste From Nearby Civilian Communities	
Alternative D (Civilian and Military Solid Waste)	
Alternative E (Civilian and Military Solid Waste)	
<b>4 INTERACTION OF FORT DIX AND NEARBY CIVILIAN COMMUNITIES .....</b>	<b>27</b>
<b>5 ECONOMIC ANALYSIS .....</b>	<b>27</b>
<b>6 CONCLUSIONS AND RECOMMENDATIONS .....</b>	<b>27</b>
Conclusions	
Recommendations	
<b>REFERENCES</b>	<b>31</b>
<b>APPENDIX A: Selection of Incinerator Plant Location and Calculation of Fuel and Operation and Maintenance Savings</b>	<b>32</b>
<b>APPENDIX B: Potential Value of Recyclable Materials at Fort Dix</b>	<b>36</b>
<b>APPENDIX C: Method of Economic Analysis and Basis of Capital Cost Estimate for Recommended Energy-Recovery Systems</b>	<b>37</b>
<b>APPENDIX D: Economic Merits of a Shredder</b>	<b>38</b>
<b>APPENDIX E: The Application of Dry Scrubbers to Waste-Wood-Fired Boilers</b>	<b>42</b>
<b>DISTRIBUTION</b>	

## TABLES

<b>Number</b>	<b>Page</b>
A Basis of Economic Analysis	4
B Summary of Energy-Recovery Alternatives	5
1 Results of Weigh Survey	12
2 Average Daily Fort Dix Refuse	12
3 Combustion Characteristics of Waste	14
4 Present Value (PV) Operation and Maintenance (O&M) Cost for Present Practice (Alternative A)	16
5 Annual O&M Cost for Proposed Landfill and Refuse Collection: Combined Fort Dix and McGuire AFB Waste Streams	18
6 Capital Investment—Alternative B	18
7 25-Year PV, O&M Costs and Credits—Alternative B	19
8 Capital Investment—Alternative C	20
9 25-Year PV, O&M Costs and Credits—Alternative C	20
10 Capital Investment Costs—Alternative D	23
11 25-Year PV, O&M Costs and Credits—Alternative D	24
12 Capital Investment Costs—Alternative E	25
13 25-Year PV, O&M Costs and Credits—Alternative E	26
14 Materials Not Acceptable to the Resource- Recovery Facility	27
15 Basis of Economic Analyses	28
16 Summary of Costs Considering Inflation	29
17 Summary of Characteristics of Solid Waste Disposal Alternatives	30
A1 Data Used in Calculating Design Capacity	32
A2 Boiler Plant 5881, Average Monthly Steam Production and Efficiency	33

#3 Steam Load and Steam Available From Waste Alternatives D and E	34
A4 Fuel and O&M Savings for Alternatives D and E	35
A5 Summary of Alternatives	35
A6 Laundry Boiler Plant 5324, Projected Average Monthly Steam Production	36
C1 Labor Costs Used When Local Costs Are Unavailable	38
D1 PV of Proposed Shredder With Lumber From Construction Demolition Available 100 Days/Year	39
D2 PV of Proposed Shredder With Lumber From Construction Demolition Available 200 Days/Year	40
D3 PV of Proposed Shredder With Lumber From Construction Demolition Available 160 Days/Year	41
E1 Gas Sample Results, Power Boiler (Waste Wood and Fuel-Oil Fired)	52

### FIGURES

Number	Page
1 Landfilled Contractor-Collected Refuse	13
2 Actual and Proposed Steam Loads	15
3 Layout of Proposed Incinerator Plant (100 × 260 ft) -- Alternative B	17
4 Steam Loads and Steam Available From Waste	21
E1 Dry Scrubber	43
E2 Cascade Impactor	44
E3 Diagram of Rock Filter-Bed Showing Impact Concept	45
E4 Integral Cyclone Unit	47
E5 Modular Dry Scrubber (800 sq ft Filter Area)	48
E6 Modular Dry Scrubber With Integral Cyclone	49
E7 Dry Scrubber Unit (365 sq ft), Weyerhaeuser Co., Snoqualmie Falls, WA	50
E8 Portable, Recirculating Dry Scrubber Field Test Unit	51

# TECHNICAL EVALUATION STUDY: ENERGY RECOVERY FROM SOLID WASTE AT FORT DIX, NJ AND NEARBY CIVILIAN COMMUNITIES

## 1 INTRODUCTION

### Background

Fort Dix is located in central New Jersey, about 18 miles southeast of Trenton in gently rolling terrain. The installation's primary mission is basic training of Army recruits.

Fort Dix and the adjacent McGuire Air Force Base (AFB) have an Interservice Support Agreement whereby Fort Dix landfills McGuire AFB's waste. In return, McGuire AFB pays its share of the landfill operating costs. The agreement is renewed annually. Directorate of Facilities Engineering personnel estimate the remaining life of the existing Fort Dix landfill to be 3 years.

An alternative landfill or solid waste management system is being sought to reduce solid waste management costs. One alternative being considered is burning of the combustible portion of solid waste, with energy recovery from a boiler in the form of steam. Steam produced in this manner often yields a significant savings in conventional fuels, with a resultant cost avoidance. For these reasons, the Facilities Engineer at Fort Dix initiated a feasibility study of energy recovery from solid waste; this report provides the results of that study.

### Objective

The objectives of this study were (1) to ascertain the technical and economic feasibility of energy and materials recovery from solid waste at Fort Dix, (2) to consider the economic feasibility of on-post energy and materials recovery from solid waste delivered from nearby civilian communities, (3) to identify the most cost-effective systems for implementing energy recovery, and (4) to furnish engineering and economic data for subsequent project development.

### Approach and Scope

A solid waste survey was conducted at Fort Dix to determine the generation rate and main constituents of the solid waste stream. The current solid waste management system was examined, and data pertaining to present steam demands were analyzed. The sale potential of recyclable materials from the waste stream was also analyzed. Data from this portion of the study served as the basis for evaluating alternative systems.

The administrator of the Office of Solid Waste Management Programs, Burlington County, NJ, and representatives of the State of New Jersey Department of Environmental Protection were consulted to determine (1) the quantitative composition of solid waste, and (2) the distribution of solid waste in the surrounding community.

Manufacturers and vendors of commercially available energy-recovery systems were contacted to obtain current performance characteristics and installed costs of hardware. Conceptual designs of technically applicable systems were prepared, and initial and recurring costs were determined for each system. The recommended system was then chosen on the basis of its savings/investment ratio (SIR). Consideration as to the feasibility of locating a future landfill within the boundaries of Fort Dix was outside the scope of this study.

## 2 BASIS FOR SYSTEM EVALUATION

### Characterization of Solid Waste

The solid waste considered in this study originates in the cantonment area, family housing area, and firing ranges at Fort Dix and McGuire AFB. All refuse, except food waste, is currently hauled to the Fort Dix landfill.

Table 1 displays the data collected during a weigh survey conducted by the U.S. Army Construction Engineering Research Laboratory (CERL). Volume data were provided by the Fort Dix contract hauler; the as-collected density was computed from these data and weigh survey records. Results indicate that Fort Dix and McGuire AFB wastes are presently landfilled at an average rate of 59.6 tons per day (TPD) on a 5-day basis (TPD<sub>5</sub>). This rate excludes 1.3 TPD<sub>5</sub> of potentially recyclable cardboard and 2.7 TPD<sub>5</sub> of wood from construction demolition.

Figure 1 presents the monthly volume of waste generated at Fort Dix and McGuire AFB taken to the landfill by the contract hauler for 2 years prior to the study. Table 2 shows average daily refuse generated at Fort Dix based on historical data on refuse hauled to the landfill by the contract hauler. The volumes used in Table 2 are 8-week averages for January and February 1976. The average density was taken from Table 1, and the computed weight determined by multiplying the volume by the average density.

**Table 1**  
**Results of Weigh Survey**

Date (1978)	Day of Week	Fort Dix* Mixed Solid Waste			Fort Dix Wood** Weight (tons)	Fort Dix Cardboard & Paper † Weight (tons)	McGuire AFB Refuse Weight (tons)	Combined Fort Dix/ McGuire AFB Refuse Weight (tons)
		Weight (tons)	Volume (cu yd)	As-collected Density (tons/cu yd)				
19 April	Monday	49.3	1,908	0.0258	3.7	1.0	35.5	84.8
20 April	Tuesday	36.0	1,808	0.0199	1.6	1.6	29.0	65.0
Average		42.7	1,858	0.0229	2.7	1.3	32.3	74.9

\* Segregated incombustibles such as steel, concrete, sand and gravel were not weighed. There was a total of five trucks carrying such waste in 2 days.

\*\* Construction demolition lumber.

† Source-segregated.

**Table 2**  
**Average Daily Fort Dix Refuse**

Day	Volume (cu yd)	Average Density (tons/cu yd)	Computed Weight (tons)
Monday	1,817	0.0229	41.6
Tuesday	1,795	0.0229	41.1
Wednesday	1,325	0.0229	30.3
Thursday	1,495	0.0229	34.2
Friday	1,665	0.0229	38.1
Saturday	815	0.0229	18.7
Weekly Total	8,912		204.0

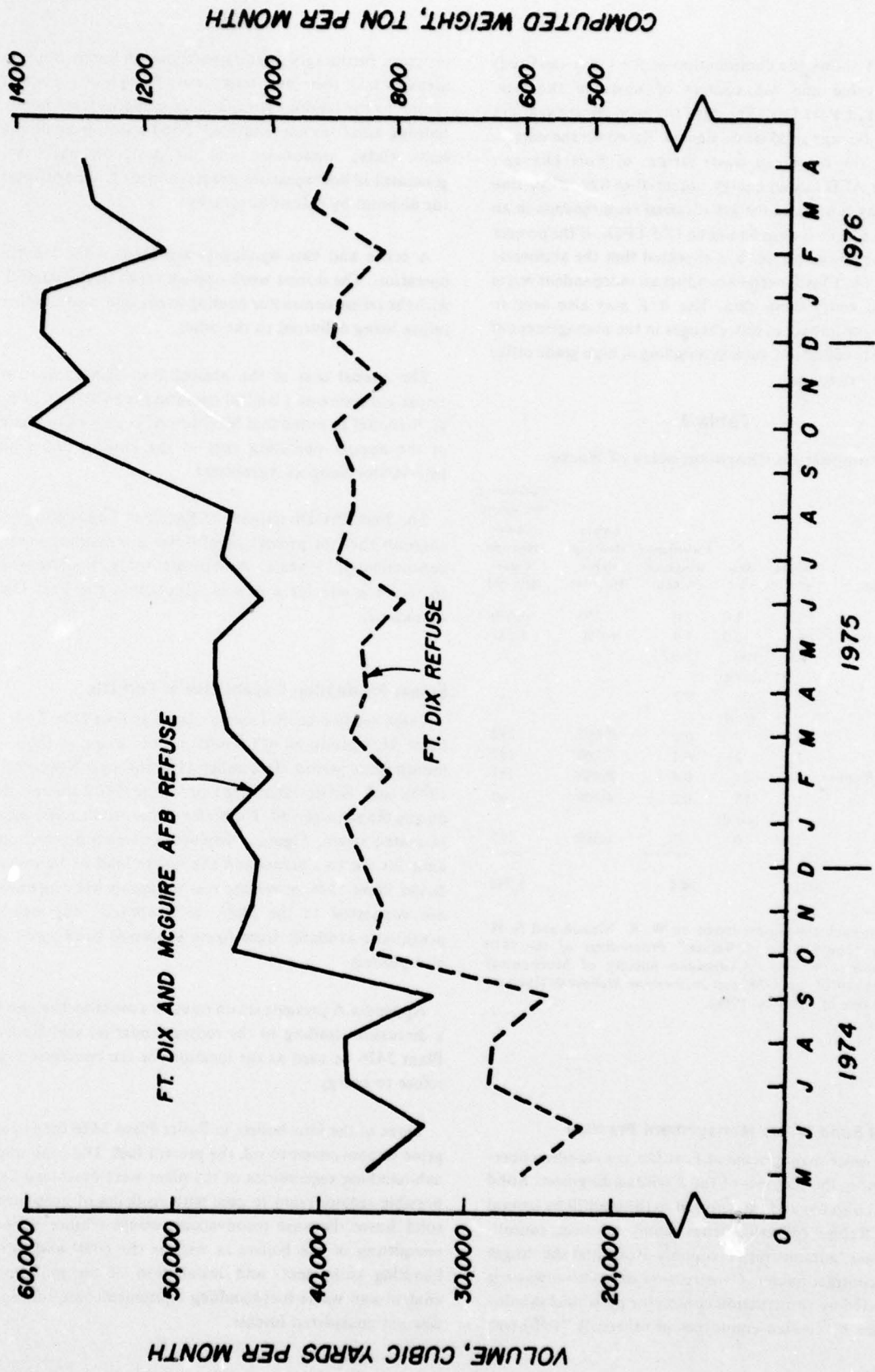

Figure 1. Landfilled contractor-collected refuse.

Table 3 shows the computation of the lower (as-fired) heating value and ash content of waste of the type generated at Fort Dix. The data for each constituent are national average solid waste figures. Based on the data in Table 3, the combined waste stream of Fort Dix and McGuire AFB has an energy potential of 822 MBtu/day on a 5-day basis, and the ash disposal requirements in an energy-recovery system would be 17.5 TPDs. If the project enters the design phase, it is expected that the architect/engineer (A/E) will need to conduct an independent waste survey to verify these data. The A/E may also need to consider the impact of any changes in the management of solid waste collection, such as recycling of high grade office paper or newspaper.

**Table 3**  
**Combustion Characteristics of Waste**

Constituent	Weight (%) <sup>*</sup>	Ash (%) <sup>*</sup>	Calculated Weighted (% Ash)	Lower Heating Value (Btu/lb) <sup>*</sup>	Calculated Weighted Lower Heating Value (Btu/lb)
Paper	50.7	4.0	2.0	7,250	3,676
Food Wastes	19.1	10.0	1.9	6,550	1,242
Metal	10.0	100	10.0	--	--
Glass	9.7	100 (est'd)	9.7	--	--
Wood	2.9	3	0.1	8,000	232
Textiles	2.6	2	0.1	7,200	187
Leather, Rubber	1.9	21	0.4	8,460	161
Misc	1.7	10 (est'd)	0.2	4,300	60
Plastics	1.4	0	0	1,300	182
<b>Total</b>	<b>100.0</b>		<b>24.4</b>		<b>5,740</b>

<sup>\*</sup>Data for each constituent based on W. R. Niessen and S. H. Chansky "The Nature of Refuse," *Proceedings of the 1970 Incinerator Conference* (American Society of Mechanical Engineers, 1970), pp 1-24; and *Incinerator Standards* (Incinerator Institute of America, 1968).

#### Current Solid Waste Management Practice

Solid waste management at Fort Dix is a standing operation under the purview of the Facilities Engineer. Solid waste is collected and transported to the landfill by several means. Refuse collection from family housing, cantonment areas, administrative/support areas, and the ranges is by a contract hauler. Construction demolition waste is transported by construction contractor personnel in some cases and by civilian employees in others. A "self-help"

program encourages military personnel in family housing areas to take their own bulky wastes, such as sofas and chairs, to the landfill. Household appliances from family housing areas are not landfilled. Food wastes from dining halls, clubs, restaurants, and the post commissary are generated in homogeneous streams and are hauled off-post for disposal by private contractor.

A crane and two bulldozers are used in the landfill operation. The dozers work opposite ends of the landfill, with the refuse contractor hauling to one end, and all other refuse being delivered to the other.

The annual cost of the present Fort Dix contractor refuse collection and landfill operation is \$416,000 (Table 4). It should be noted that McGuire AFB pays a fair share of the annual operating cost of the landfill under an Interservice Support Agreement.

The Fort Dix Directorate of Facilities Engineering recognizes that the present landfill has a remaining life of approximately 3 years. A separate study is underway to locate a site for a new landfill within the Fort Dix boundaries.

#### Steam Production Capabilities at Fort Dix

There are two central steam plants at Fort Dix. Boiler Plant 5426 produced 421.6 million lb of steam in the 12-month data period (December 1974 through November 1975), and Boiler Plant 5881 produced 392.2 million lb during the same period. The boiler plants produce 100-psig saturated steam. Figure 2 displays the steam production data for the two plants and the future load of Laundry Boiler Plant 5324, providing that the family housing units are connected to the plant, as proposed. The steam potentially available from firing processed solid waste is also plotted.

Appendix A presents steam rates on a monthly basis and a discussion leading to the recommendation that Boiler Plant 5426 be used as the location for the conversion of refuse to energy.

Three of the four boilers in Boiler Plant 5426 fired coal prior to conversion to oil, the present fuel. The coal- and ash-handling capabilities of the plant were examined for possible reconversion to coal with co-firing of processed solid waste. Because reconversion would require major retrofitting of the boilers as well as the coal- and ash-handling equipment, and installation of air pollution control and waste-fuel-handling equipment, this concept was not considered further.

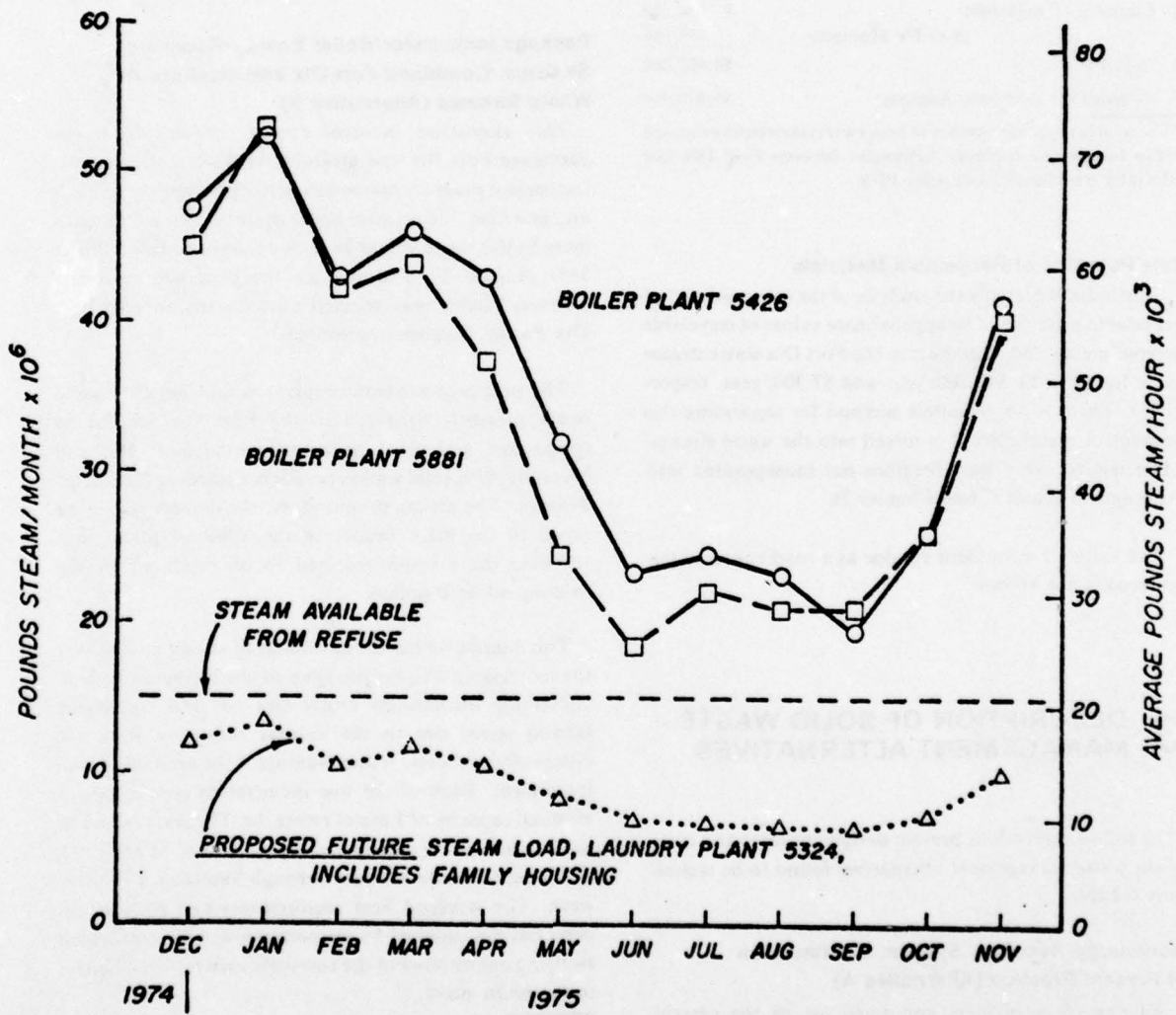

Figure 2. Actual and proposed steam loads.

**Table 4**  
**Present Value (PV)**  
**Operation and Maintenance (O&M) Cost**  
**for Present Practice (Alternative A)**

1. Landfill Operation		
a. One crane operator (\$6.21/hr)*	\$	12,916
b. Two equipment operators (\$6.05/hr)		25,168
c. MTO crane 2304 hr × \$4.86/hr		11,197
d. D/7 tractor 3840 hr × \$4.86/hr		18,662
	Subtotal	\$ 67,943
2. Fort Dix Contract Refuse Collections	\$	348,000
3. Total	\$	415,943
		× 1.07
4. Escalated to June 1977	\$	445,059
		× 1.29
5. Escalated to June 1981	\$	574,100
25-yr PV Multiplier		× 9.524
6. 25-yr PV	\$5,467,700	
7. Rounded for Economic Analysis	\$5,470,000	

\*The hourly rates and number of hours were taken from proposed FY76 Interservice Support Agreement between Fort Dix and McGuire AFB dated 22 October 1975.

#### **Sale Potential of Recyclable Materials**

Appendix B presents the analysis of the sale potential of recyclable materials. The approximate values of recyclable ferrous metals and aluminum in the Fort Dix waste stream were found to be \$10,200/year and \$7,300/year, respectively. There is no economic method for separating this amount of metal once it is mixed into the waste stream. Materials recovery was therefore not incorporated into Alternatives B and C (see Chapter 3).

The value of incinerator residue as a road construction material is not known.

### **3 DESCRIPTION OF SOLID WASTE MANAGEMENT ALTERNATIVES**

The following sections present design concepts and costs of the waste management alternatives found to be technically feasible.

#### **Nonenergy-Recovery System: Continuation of Present Practice (Alternative A)**

Alternative A involves continued use of the present practice of hauling solid waste from Fort Dix and McGuire AFB to the landfill at Fort Dix. This system is technically satisfactory. It has the advantage of requiring no immediate capital investment, except for the new landfill, when

it is required. Its disadvantages are wastage of the energy potential of solid waste and high annual costs. The annual cost associated with Alternative A is assumed to be equal to the current annual cost of the system--\$445,000 in FY77 dollars. The 25-year PV cost is \$5.5 million; this includes all operation and maintenance (O&M) costs, such as the contract, labor, utilities, repair, and maintenance. Since the value of land is excluded from Army economic analyses\* unless the land in question is to be purchased or sold as part of the alternative,<sup>2</sup> the costs associated with the development of a new landfill were excluded from the analysis. The costs of developing the landfill would be the same for each alternative.

#### **Package Incinerator/Boiler Energy-Recovery Systems: Combined Fort Dix and McGuire AFB Waste Streams (Alternative B)**

This alternative involves energy recovery from the combined Fort Dix and McGuire AFB waste streams. An incinerator plant accommodating five package controlled-air, grateless, incinerator/boiler systems designed to burn mixed solid waste would be built adjacent to Boiler Plant 5881 (Figure 3). The site for the proposed resource-recovery facility was selected after discussion with Fort Dix Facility Engineer personnel.

The proposed incinerator plant would burn the solid waste presently delivered to the Fort Dix landfill by contractors and other personnel in the Fort Dix and McGuire AFB solid waste operation, excluding "self-help" delivery. The steam produced by the boilers would be piped to the main header in the adjacent plant, thus reducing the amount required to be produced by the existing oil-fired boilers.

This alternative has the advantage of saving money over the anticipated 25-year life span of the incinerator plant, conserving increasingly costly fuel oil, and conserving landfill space due to the volume reduction from the combustion process. A disadvantage is the need for capital investment. Each of the five incinerators would have a nominal capacity of 1 ton of refuse/hr. The plant would be sized to handle the anticipated design peak of 74.6\*\* TPD, and would operate Monday through Saturday, 17 shifts/week. The weekend heat requirements and peak steam demands not satisfied by incineration would be provided by firing one or more of the currently used oil-fired boilers in the boiler plant.

\*Appendix C describes the method of economic analysis.

\*\*This design peak is calculated in Appendix A.

<sup>2</sup>Economic Analysis and Program Evaluation for Resource Management, AR 11-28 (Department of the Army, 1975).

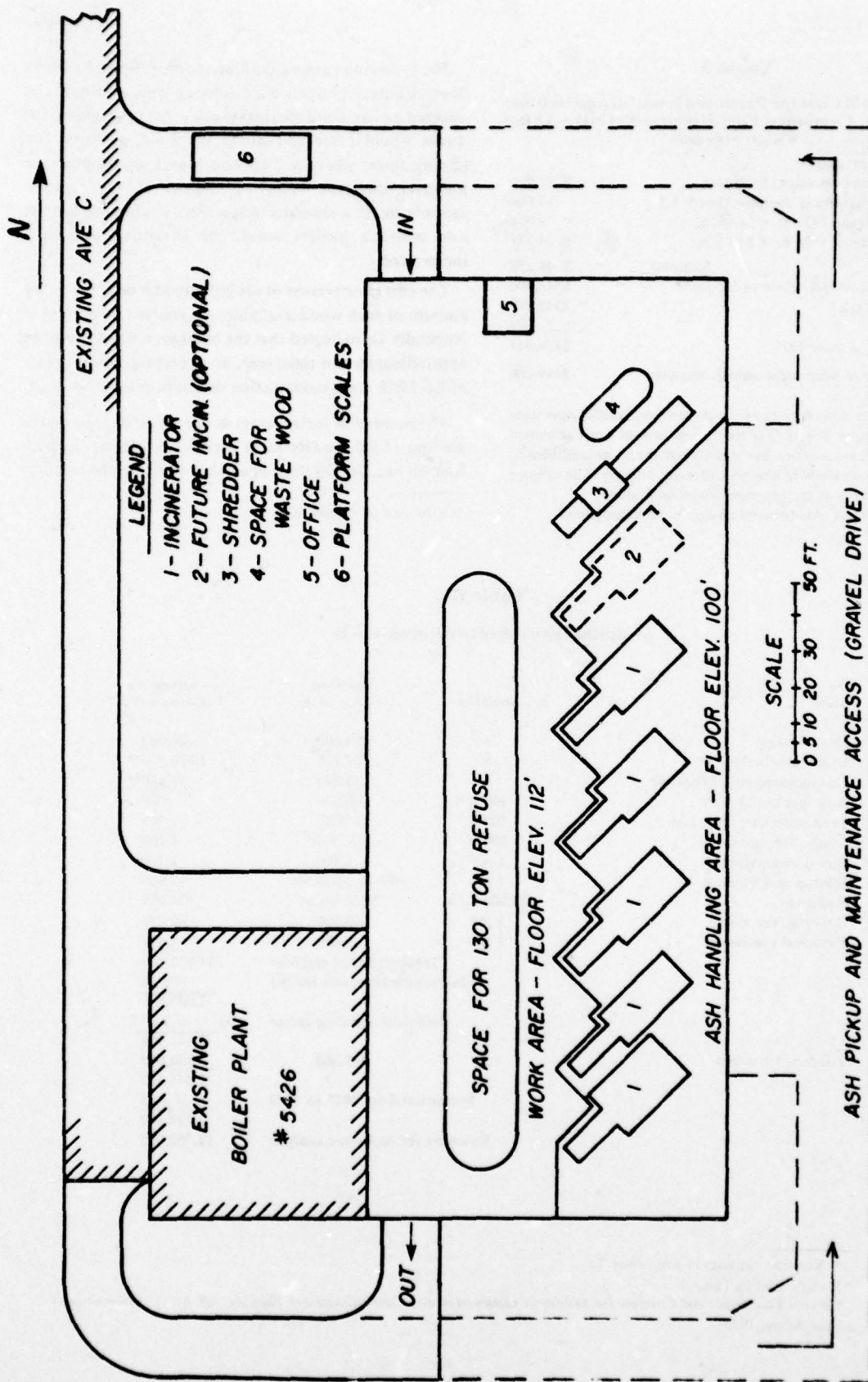

Figure 3. Layout of proposed incinerator plant (100 ft x 260 ft) --Alternative B.

**Table 5**

**Annual O&M Cost for Proposed Landfill and Refuse Collection: Combined Fort Dix and McGuire AFB Waste Streams**

1. Landfill operation	
a. One crane operator (\$6.21/hr)	\$ 12,916
b. One* equipment operator (\$6.05/hr)	12,584
c. MTO crane 1920 hr × \$4.86/hr	9,331
d. D/7 tractor 1920 hr × \$4.86/hr	<u>\$ 9,331</u>
Subtotal	\$ 44,192
2. Fort Dix contract refuse collection**	\$348,000
3. Sum of 1 + 2	\$392,192
	<u>× 1.07</u>
4. Escalated to June 1977	\$419,645
Rounded for economic analysis	\$419,600

\* The main difference between the present landfill operation and Alternatives B and C is the elimination of one equipment operator due to reduction in the daily volume to be landfilled to one-third to one-half of the present daily volume. The volume reduction occurs at the proposed incinerator plant.

\*\*From Table 4. Assumes no change in contract price.

The following paragraphs describe the proposed process flow. Collection vehicles delivering refuse would be weighed on standard platform scales. After weighing, the trucks would enter and dump the solid waste on the tipping floor, where a front-end loader would push the material into the receiving hopper of the ram-fed incinerator. If a shredder is installed, demolition lumber and wooden pallets would be shredded and then incinerated.

The cost effectiveness of using a shredder depends on the amount of such wood available. An analysis, presented in Appendix D, indicated that the breakeven point would be approximately 416 tons/year, an average generation rate of 2.6 TPD, from construction demolition 160 days/year.

The number of incinerators in use would depend on the amount of solid waste to be incinerated. However, with four on line, 20,300 lb of steam/hr\* could be produced by

\*Calculated in Appendix A.

**Table 6**

**Capital Investment--Alternative B**

Item	Quantity	Installed Unit Cost (\$)	Engineering Estimate (\$)
Scales, truck	1	24,000	24,000
Incinerator w/ boiler*	5	204,100	1,020,500**
Nonstandard boiler controls	5	10,300	51,300**
Aux fuel line, 3/4 in.	300 ft	3.00/ft	900
Feed waterline, insul 1 in.	300 ft	5.75/ft	1,700
Steam line, insul 4 in.	300 ft	13.75/ft	4,100
Piping connections	1 job	1,100	1,100
Startup and training	1 job	4% of 1,020,500	40,800
Building	26,000 sq ft	24.00/sq ft	624,000
Building, site work	1 job	80,000	80,000
Electrical substation	1 job	6,800	6,800
		Total empirical estimate	\$1,855,000
		Location adjustment for NJ	× 1.08 †
			<u>2,003,600</u>
		Technical updating factor	× 1.07 †
			<u>2,143,900</u>
Loaders, front-end	2	\$15,000	+30,000
			<u>2,173,900</u>
		Escalation from 1977 to 1980	× 1.26
			<u>2,739,100</u>
		Rounded for economic analysis	\$2,750,000

\* Nominal capacity, 1 ton refuse/hr

\*\* Data used in Table 7

† From *Empirical Cost Estimate for Military Construction and Cost Adjustment Factors*, AR 415-17 (Department of the Army, 1975)

**Table 7**  
**25-Year PV, O&M Costs and Credits--Alternative B**

Item	Quantity	Unit Cost (\$)	Annual Cost (FY77)((\$000))	Annual Cost (FY81)((\$000))	25-yr PV Multiplier	PV 25-yr Costs (\$000)
Front-end loader operator	7,072 man-hr/yr	7.28 / hr	51.5	66.4	9.524	632.5
Incinerator operator	7,072 man-hr/yr	6.87 / hr	48.6	62.7	9.524	579.9
Laborer	2,080 man-hr/yr	6.87 / hr	14.3	18.4	9.524	170.6
Ash & reject disposal	4,537 tons	6.50 / ton	29.5	38.0	9.524	352.0
Maintenance (4% of Table 6)			42.9	55.3	9.524	526.7
Refuse collection & landfill operation (Table 5)	1 job		419.6	541.3	9.524	5,155.7
Auxiliary fuel (accounted for in Appendix A)						-0-
Electricity	186,200 kWh	0.026 / kWh	4.8	8.8	18.049	158.2
Fuel, front-end loader	14,140 gal	0.55	7.8	14.1	20.050	282.2
					Total costs	7,857.8
Fuel credit (Appendix A)	1,050,000 gal/yr	0.36	378.0	684.2	20.050	13,717.8
Labor credit	3,536 man-hr/yr	6.87 / hr	24.3	31.3	9.524	290.1
					Total credits	14,007.9
					Credits minus costs rounded for economic analysis	\$ 6,140.0

feeding the average amount of solid waste collected to the incinerators. On days when less than the average amount of waste is collected, only two or three incinerators would be used. The fifth incinerator is provided to handle peak loads and as a backup when another unit is down for maintenance.

Package controlled-air incinerator units with an auxiliary burner to ignite the solid waste and an extra burner to provide control and additional steam as demanded are commercially available. Package incinerators have been designed and tested to meet present New Jersey air pollution standards.

Tables 5 through 7 provide details and calculations for determining the costs and economics of Alternative B. Table 5 gives the quantities and costs for the proposed waste collection system. Table 6 gives a breakdown of the capital required under this concept. Table 7 lists recurring O&M costs, including the costs of utilities, labor, maintenance, and proposed refuse collection.

#### **Field-Erected Incinerator Boiler Energy-Recovery System (Alternative C)**

This alternative considers energy recovery of the combined Fort Dix and McGuire AFB refuse streams using a field-erected plant consisting of one waterwall furnace equipped to fire ram-fed refuse on a three-flight double reciprocating grate stoker. The plant would be located adjacent to Boiler Plant 5881 and the design points would

be as calculated for Alternative B in Appendix A. Ash removal would be by quench and drag conveyor. A dry granular media scrubber or other air pollution control device would be used for air pollution control.

Field-erected units, which have a more extensive operating history than package units, are designed to accommodate a particular waste. Several designs are available. Of 22 energy-recovery incinerator plants built or under construction in the United States between 1956 and 1965,<sup>1</sup> two had units with a processing capacity of less than 100 TPD; 10 had units in the range of 100 to 150 TPD; the remaining 10 had capacities ranging from 180 to 350 TPD. The only Department of Defense refuse-fired boiler plants are at Norfolk, VA, and have been in operation since 1967. Each unit has a capacity of 180 TPD. If a shredder is installed, demolition lumber and wooden pallets can be incinerated; its cost effectiveness depends on the amount of such wood available (Appendix D).

Tables 8 and 9 provide the detailed capital investment and annual O&M cost of Alternative C.

#### **Resource Recovery From Solid Waste From Nearby Civilian Communities**

The preceding alternatives considered only the waste generated at Fort Dix and McGuire AFB as a potential resource. The next two alternatives consider the economics

<sup>1</sup>Municipal Incineration - A Review of Literature, No. AP-79 (Environmental Protection Agency, 1971), Appendix.

**Table 8**  
**Capital Investment--Alternative C**

Item	Quantity	Installed Unit Cost (\$)	Engineering Estimate (\$)
Scales, truck	1	24,000	24,000
Field-erected boiler	1	1,025,000	1,025,000
Ash handling	1	100,000	100,000
Air pollution control	1	200,000	200,000
Stack and breeching	1	80,000	80,000
Auxiliary fuel line, 3/4 in	300 ft	3.00 ft	900
Feedwater, insul 1 in	300 ft	5.75 ft	1,700
Steam line, insul 4 in	300 ft	13.75 ft	4,100
Piping connections	1 job	1,100	1,100
Startup and training (2% of Table 9)	1 job	26,500	26,500
Building, 20 ft high	16,000 sq ft	24 sq ft	384,000
Building, 36 ft high	2,800 sq ft	36 sq ft	100,800
Building, site work	1 job	40,000	40,000
Electrical substation	1 job	6,800	6,800
Total empirical estimate			\$1,944,900
Location adjustment for NJ			× 1.08*
			2,154,500
Technical updating factor			× 1.07*
			2,305,300
Loaders, front-end	2		+30,000
			2,335,300
Escalated to FY80			× 1.26
			2,942,800
Rounded for economic analysis			\$2,950,000

\*From *Empirical Cost Estimates for Military Construction and Cost Adjustment Factors*, AR 415-17 (Department of the Army, 1975)

**Table 9**  
**25-Year PV, O&M Costs and Credits--Alternative C**

Item	Quantity	Unit Cost (\$)	Annual Cost (FY77)((\$000)	Annual Cost (FY81)((\$000)	25-yr PV Multiplier	PV 25-yr Costs (\$000)
Front-end loader operator	7,072 man-hr / yr	7.28 / hr	51.5	66.4	9.524	632.5
Incinerator operator	7,072 man-hr / yr	6.87 / hr	48.6	62.7	9.524	579.9
Laborer	2,080 man-hr / yr	6.87 / hr	14.3	18.4	9.524	170.6
Ash & reject disposal	4,537 tons	6.50 / ton	29.5	38.0	9.524	352.0
Maintenance			104.8	135.1	9.524	1,250.6
Refuse collection & landfill operation (Table 5)	1 job		419.6	541.3	9.524	5,155.7
Auxiliary fuel (accounted for in Appendix A)						-0-
Electricity	525,000 kWh / yr	0.026 kWh	13.7	24.7	18.049	455.9
Fuel, front-end loader	14,140 gal / yr	0.55 / gal	7.8	14.1	20.050	282.2
Total costs						8,869.4
Labor credit	3,536 man-hr / yr	6.87	-24.3	-31.3	9.524	290.0
Fuel credit (Appendix A)	1,100,000 gal / yr	0.36	396.0	716.8	20.050	14,371.8
Total credits						14,661.8
Credits minus costs rounded for economic analysis						\$ 5,790.0

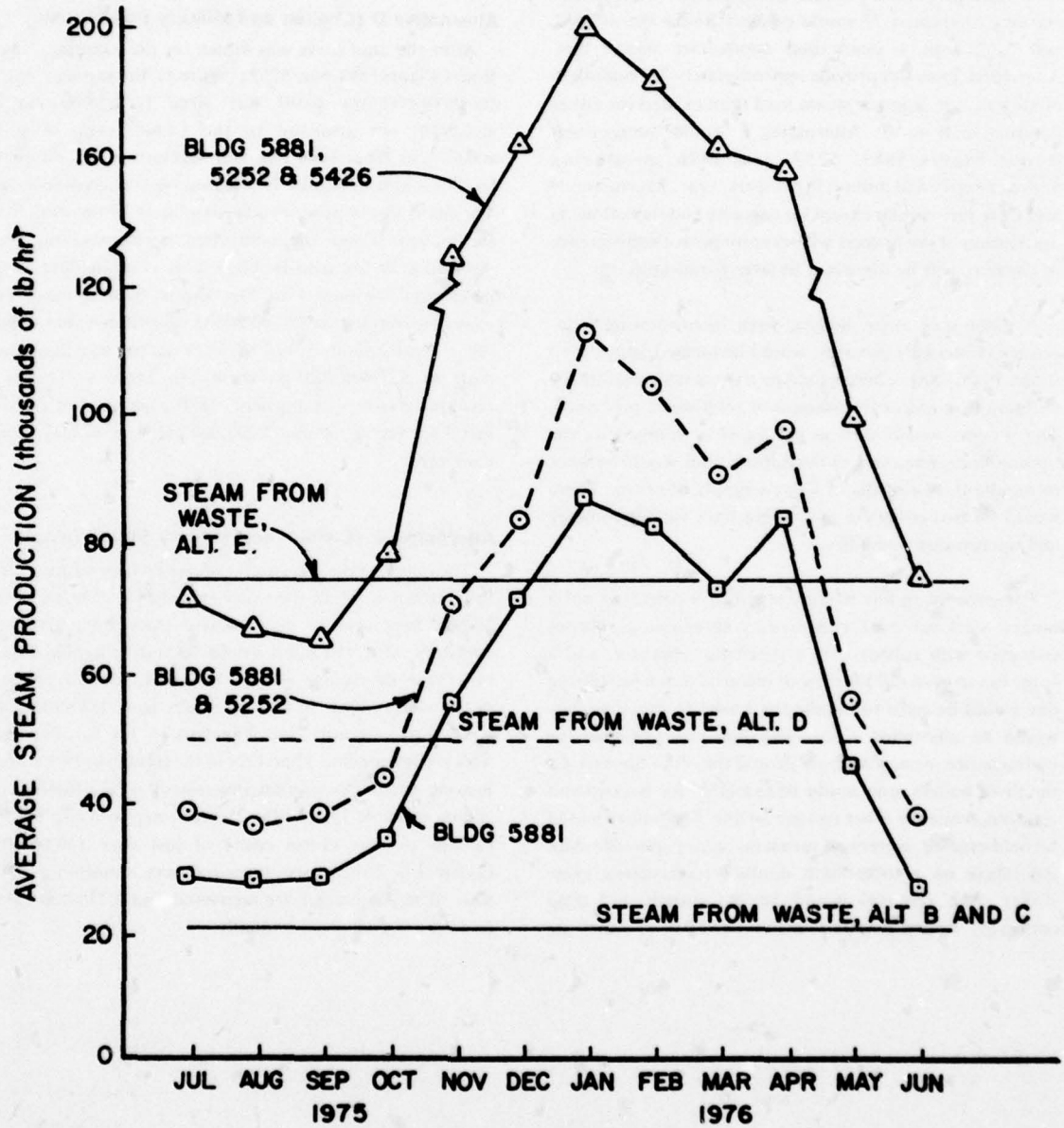

Figure 4. Steam loads and steam available from waste (thousands of pounds steam/hr).

of including the civilian community in the Fort Dix and McGuire AFB waste stream. The area immediately surrounding Fort Dix is largely residential; Mount Holly, 10 miles west, is the largest local city, with a population of 14,000. A review of Figure 2 shows that the energy (steam) from military waste exceeds the load of the Laundry Boiler Plant and nearly satisfies the load of Boiler Plant 5426 or Boiler Plant 5881 several months of the year. Figure 4 shows two possibilities of increasing the size of the energy market. Alternative D would connect Boiler Plants 5881 and 5252 with a steam and condensate return line. Alternative D would provide approximately 295 million lb of steam/year, a larger steam load than existed for either Alternative B or C. Alternative E would interconnect Boiler Plants 5881, 5252, and 5426, producing approximately 480 million lb of steam/year. Alternatives D and E are very similar except for capacity and the following description of the process will serve for both; the difference in capacity will be discussed in later paragraphs.

A plant with three boilers, each incorporating field-erected, waterwall furnaces, would be located adjacent to Boiler Plant 5881. There would be a truck scale outside the building to monitor the amount of solid waste processed. The process would start as the waste is dumped on the tipping floor. Each side of the tipping floor would be sized to handle three-fourths of a day's supply of refuse. There would be two complete processing lines for redundancy and operational reliability.

The processing line would consist of a conveyor pit, a hinged steel belt feed conveyor, a shredder, an output conveyor with rubber belt, a magnetic separator, and a surge bin to even out the flow of material. Each processing line would be sized to handle the waste. In practice, they would be alternated daily, with one line available for maintenance, or as a backup, should the other line fail. Of the three boilers, one would be available for backup and rotation, while the other two are on line. The boilers would be field-erected, waterwall furnaces, equipped to fire ramfed refuse on a three-flight double reciprocating grate stoker. Ash removal would be by quench and drag conveyor. A dry granular media scrubber or other air

pollution control device would be used for air pollution control.

Field-erected units, which have a more extensive operating history than package units, are designed to accommodate a particular waste. Several designs are available.

#### **Alternative D (Civilian and Military Solid Waste)**

After the load curve was drawn for the combination of Boiler Plants 5881 plus 5252 (Figure 4), the capacity of the resource-recovery plant was sized for 50,000 lb of steam/hr. In addition to the 18,600 tons of solid waste/year from Fort Dix and McGuire AFB, the plant would be able to handle 33,500 tons/year of civilian waste. The plant would produce approximately 295 million lb of steam/year from the combined waste stream. (See Appendix A for calculations.) This is equivalent to 21 percent of the total Fort Dix annual heating load. The capital investment is \$9,790,000 as shown in Table 10 and the 25-year operation cost is a PV saving (credits minus cost) of \$21,400,000, as shown in Table 11. From a resource-recovery standpoint, 1880 tons/year of ferrous metal are recovered and 2,300,000 gal/year of fuel oil are conserved.

#### **Alternative E (Civilian and Military Solid Waste)**

The plant for this alternative was sized to produce 75,000 lb of steam/hr from the waste stream. In addition to the 18,600 tons/year of solid waste from Fort Dix and McGuire AFB, the plant would be able to handle 55,300 tons/year of civilian waste. The plant would produce nearly 480 million lb of steam/year from the combined solid waste stream. (See Appendix A for calculations.) This is equivalent to 35 percent of the total Fort Dix annual heating load. The capital investment is \$13,100,000, as shown in Table 12, and the 25-year operation cost is a PV savings (credits minus costs) of just over \$40,000,000 (Table 13). From a resource-recovery standpoint, 2670 tons of ferrous metal are recovered and 3,730,000 gal of fuel oil are conserved annually.

**Table 10**  
**Capital Investment Costs--Alternative D**

Item	Quantity	Unit Cost (\$)	Cost (\$)
Scales, truck	1	24,000	24,000
Conveyor pit	2	6,000	12,000
Steel belt conveyor	2	30,000	60,000
Shredder, 25 tons/hr	2	150,000	300,000
Dust control	1	12,000	12,000
Rubber belt, outlet conveyor	2	12,000	24,000
Magnetic metal separator	2	42,000	84,000
Surge bin	2	14,500	29,000
Conveyors to stokers	4	6,000	24,000
Boilers, 25,000 lb/hr	3	1,025,000	3,075,000
Air pollution control	3	200,000	600,000
Stack and breeching	1	100,000	100,000
Ash handling	1	125,000	125,000
Building, 20-ft clear height	16,000 sq ft	24/sq ft	384,000
Building, 36-ft clear height	16,300 sq ft	36/sq ft	586,800
Building, misc site work	1 job	75,000	75,000
Electrical substation	1	12,000	12,000
Steam lines			
insul in bldg, 10-in. dia	300 ft	33/ft	9,900
in conduit, underground, 4-in. dia	7400 ft	105/ft	777,000
Condensate return lines			
insul in bldg, 6-in. dia	300 ft	22/ft	6,600
in conduit, underground, 4-in. dia	7,400 ft	46/ft	340,400
Steam manholes	4	6,300	25,200
Road and parking lot	700 sq yd	14.80/sq yd	10,400
		Total empirical estimate	6,696,300
		Location adjustment, NJ	× 1.08*
			7,232,000
		Technical updating factor	× 1.07*
			7,738,200
Front-end loaders	2	15,000	30,000
			7,768,200
		Inflation to midpoint of construction (June 1980)	× 1.26
			9,788,000
		Rounded for economic analysis	\$9,790,000

\*From *Empirical Cost Estimates for Military Construction and Cost Adjustment Factors*, AR 415-17 (Department of the Army, 1975)

**Table 11**  
**25-Year PV, O&M Costs and Credits--Alternative D**

Item	Quantity	Unit Cost (\$)	Annual Cost (FY77)(\$000)	Annual Cost (FY81)(\$000)	25-yr PV Multiplier	PV 25-yr Costs (\$000)
Front-end loader operator	7,488 man-hr/yr	7.28/hr	54.5	70.3	9.524	669.7
Lead boiler operator	7,488 man-hr/yr	7.28/hr	54.5	70.3	9.524	669.7
Boiler operator	7,488 man-hr/yr	6.87/hr	51.4	66.4	9.524	632.0
Shredder operator	7,488 man-hr/yr	6.87/hr	51.4	66.4	9.524	632.0
Laborer	2,080 man-hr/yr	6.87/hr	14.3	18.4	9.524	175.6
Ash & reject disposal	13,035 tons/yr	4.18/ton*	54.5	70.3	9.524	669.4
Maintenance (5% of Table 10)			198.5	256.1	9.524	2,438.8
Maintenance (2% of Table 10)			22.7	29.3	9.524	278.6
Refuse collection & landfill operation (Table 5)			419.6	541.3	9.524	5,155.7
Auxiliary fuel (accounted for in Appendix A)						-0-
Electricity	1,044,000 kWh/yr	0.026 kWh	27.1	49.1	18.049	886.8
Fuel, front-end loader	14,140 gal/yr	0.55 gal	7.8	14.1	20.050	282.2
Water	7,100,000 gal/yr	0.0005 gal	3.6	4.6	9.524	43.6
					<b>Total Costs</b>	<b>\$12,534.1</b>
Fuel credit (Appendix A)	2,300,000 gal/yr	0.36 gal	828.0	1499.0	20.050	30,049.0
O&M credit			265.6	342.6	9.524	3,263.2
Ferrous metal credit (Appendix B)	1,880 tons/yr	26.70/ton	50.1	64.7	9.524	615.9
					<b>Total credits</b>	<b>33,928.1</b>
					<b>Credits minus costs rounded for economic analysis</b>	<b>\$21,400</b>

\* The figure of \$4.18/ton assumes that Burlington County would arrange to have the ashes transported to the landfill at no cost to the Federal Government.

**Table 12**  
**Capital Investment Costs--Alternative E**

Item	Quantity	Unit Cost (\$)	Cost (\$)
Scales, truck	1	24,000	24,000
Conveyor pit	2	6,000	12,000
Steel belt conveyor	2	30,000	60,000
Shredder, 25 tons/hr	2	150,000	300,000
Dust control	1	12,000	12,000
Rubber belt, outlet conveyor	2	12,000	24,000
Magnetic metal separator	2	42,000	84,000
Surge bin	2	21,000	42,000
Conveyors to stokers	4	6,000	24,000
Boilers, 37,500 lb/hr	3	1,450,000	4,350,000
Air pollution control	3	300,000	900,000
Stack and breeching	1	100,000	100,000
Ash handling	1	140,000	140,000
Bldg, 20-ft clear height	18,600 sq ft	24/sq ft	446,400
Bldg, 36-ft clear height	19,000 sq ft	36/sq ft	684,000
Bldg, misc site work	1 job	80,000	80,000
Electrical substation	1	12,000	12,000
Steam lines			
insul, bldg, 12-in. dia	300 ft	35/ft	10,500
in conduit, underground, 12-in. dia	7400 ft	135/ft	999,000
in conduit, underground, 8-in. dia	2600 ft	84/ft	218,400
Condensate return lines			
insul, bldg, 6-in. dia	300 ft	22/ft	6,600
in conduit, underground, 5-in. dia	7400 ft	53/ft	392,200
Steam manholes	7	6,300	41,100
Road and parking lot	800 sq yd	14.80/sq yd	11,800
			<hr/>
		Total empirical estimate	8,974,000
		Location adjustment, NJ	× 1.08*
			<hr/> 9,691,900
		Technical updating factor	× 1.07*
			<hr/> 10,370,400
Front-end loader	2	15,000	30,000
			<hr/> 10,400,400
		Inflation to midpoint of construction (June 1980)	× 1.26
			<hr/> 13,104,400
		Rounded for economic analysis	\$13,100,000

\* From *Empirical Cost Estimates for Military Construction and Cost Adjustment Factors, AR 415-17* (Department of the Army, 1975)

**Table 13**  
**25-Year PV, O&M Costs and Credits--Alternative E**

Item	Quantity	Unit Cost (\$)	Annual Cost (FY77)(\$000)	Annual Cost (FY81)(\$000)	25-yr PV Multiplier	PV 25-yr Costs (\$000)
Front-end loader operator	7,488 man-hr /yr	7.28	54.5	70.3	9.524	699.7
Lead boiler operator	7,488 man-hr /yr	7.28	54.5	70.3	9.524	699.7
Boiler operator	7,488 man-hr /yr	6.87	51.4	66.4	9.524	632.0
Shredder operator	7,488 man-hr /yr	6.87	51.4	66.4	9.524	632.0
Laborer	2,080 man-hr /yr	6.87	14.3	18.4	9.524	175.6
Ash & reject disposal	18,450 tons	4.18*	77.1	99.5	9.524	947.5
Maintenance						
(5% of Table 12)			279.4	360.4	9.524	3,432.7
Maintenance						
(2% of Table 12)			32.5	42.0	9.524	399.7
Refuse collection & landfill						
operation (Table 5)	1 job		419.6	541.3	9.524	5,155.7
Electricity	1,566,000 kWh	0.026	40.7	73.7	18.049	1,330.1
Fuel, front-end loader	14,140 gal	0.550	7.8	14.1	20.050	282.2
Water	10,600,000 gal /yr	0.0005 /gal	5.3	6.8	9.524	65.1
					Total costs	14,452.0
Fuel credit (Appendix A)	3,730,000 gal /yr	0.36 /gal	1342.8	2430.5	20.050	48,731.0
O&M credit			402.0	518.6	9.524	4,939.0
Ferrous metal credit						
(Appendix B)	2,670 tons /yr	26.70 /ton	71.6	92.3	9.524	879.1
					Total credits	54,549.1
					Credits minus costs rounded for economic analysis	\$40,100

\*The figure of \$4.18 /ton assumes that Burlington County would arrange to have the ashes transported to the landfill at no cost to the Federal Government.

## 4 INTERACTION OF FORT DIX AND NEARBY CIVILIAN COMMUNITIES

Alternatives D and E, described and analyzed in the previous section of this report, considered the use of civilian waste as a resource to Fort Dix. This section discusses administrative as well as economic impacts.

If Fort Dix decides to recommend a regional approach (Alternative D or E) for funding and eventual construction, several areas of concern must be worked out with the civilian agency\* that has overall responsibility for solid waste disposal. There must be agreement on the wastes that are acceptable to Fort Dix. (Table 14 is a suggested list of materials to be excluded from the wastes delivered to Fort Dix.) There should be agreement on times per day and days per week that waste would be accepted at the resource-recovery facility, and on the quantities of civilian waste acceptable. For instance, if Alternative E is selected, then 7 months of the year, 6 days/week, approximately 190 TPD of civilian waste should be delivered. During the 5 months of lower stream demand, 6 days/week, 160 TPD should be delivered. There should be agreement on methods and amounts of economic participation in the investment and/or operating cost by the civilian communities in the resource-recovery facility. Note that Tables 11 and 13 used the assumption that the ash from the facility would be transported to the disposal site by the civilians as a means of sharing the operating cost.

Note: any agreement between Fort Dix and the civilian community may have to conform to AR 410-12,<sup>4</sup> which governs the sale and delivery of government services.

## 5 ECONOMIC ANALYSIS

DOD has prepared and disseminated short-term absolute escalation rates and long-term differential rates for fuels; this report incorporated only computations using inflation rates.<sup>5</sup>

\*Within Burlington County the responsible civilian agency is the Office of Solid Waste Management Programs.

<sup>4</sup>Utilities Contract, AR 420-41 (Department of the Army, 1976).

<sup>5</sup>Revised Energy Conservation Investment Program (ECIP), Directorate of Facilities Engineering (OCE), Utilities Branch, April 1977).

Table 14

### Materials Not Acceptable to the Resource-Recovery Facility\*

1. Hazardous waste
2. Infectious waste
3. Bulk liquids and semiliquids
4. Sludge containing free moisture
5. Flammable or volatile substances
6. Raw animal manure
7. Septic tank pumpings
8. Raw sewage sludge
9. Industrial process waste
10. White goods, such as stoves, refrigerators, hot water heaters, and similar appliances
11. Automobile or truck parts: engines, transmissions, drive train, axles, fuel tanks, and suspension parts
12. Machine parts, such as shafts, bearings and gears
13. Metal, such as steel plate or bar stock
14. Cables, such as steel cable, wire rope, electric wire longer than 4 ft or in coils or bales
15. Construction demolition materials, such as concrete foundations, concrete block, brick, demolition and building debris
16. Miscellaneous: fire hose, large pieces of carpet, rags, cloth, tree limbs in excess of 4 ft long or 4 in. in diameter, mattresses and bedsprings.

\* Note: Items 1 through 9 as defined in the 8 December 1975 *Land Disposal of Solid Waste Operational Plan* (Fort Dix, NJ).

Table 15 shows the inflation rates used in computing the inflated costs (and savings) for the alternatives. Table 16 shows these costs in the format of Figure 2-3, AR 11-28.<sup>6</sup> Table 17 is a summary of all alternatives.

## 6 CONCLUSIONS AND RECOMMENDATIONS

### Conclusions

The following conclusions are based on the analysis of alternative solid waste management systems for Fort Dix:

1. Energy-recovery incineration of wastes generated at Fort Dix and McGuire AFB is technically and economically feasible (Alternatives B and C).

<sup>6</sup>Economic Analysis and Program Evaluation for Resource Management, AR 11-28 (Department of the Army, 1975).

**Table 15**

**Basis of Economic Analyses**

**Date of Cost Estimate: June 1977**  
**First Year of Project Operation: FY81**  
**Length of Economic Life: 25 years**  
**Midpoint of Construction: June 1980**

**Unit Costs and Escalation Rates for Recurring (Annual) Cost Elements**

Recurring Cost Element	Cost (\$/unit)	Short-term Absolute Escalation Rates (%/yr)				Equivalent Short-term Multiplier	Long-term DER** (%/yr)	25-yr PV Multiplier †
		FY78	FY79	FY80	FY81			
Labor		7.0	6.6	6.5	6.5	1.29	0	9.524
Construction		8.0	8.0	8.0	--	1.26	0	9.524
Material		7.0	6.6	6.5	6.5	1.29	0	9.524
Maintenance	(5% of Capital)	7.0	6.6	6.5	6.5	1.29	0	9.524
Fuel oil	0.36 / gal	16.0	16.0	16.0	16.0	1.81	8.0	20.050
Electricity	0.026 kWh	16.0	16.0	16.0	16.0	1.81	7.0	18.049
Water	0.50 / kgal	5.0	5.0	5.0	5.0	1.22	0	9.524
Ferrous metals*	26.70 / ton	5.0	5.0	5.0	5.0	1.22	0	9.524
Vehicle fuel	0.55 / gal	16.0	16.0	16.0	16.0	1.81	8.0	20.050

\* Materials reclaimed from waste stream; unit value is net figure and excludes costs of marketing.

\*\* DER is differential escalation specified by DOD policy.

† PV multiplier from Naval Facilities Engineering Command (NAVFAC) Document P-442.

**Table 16**  
**Summary of Costs Considering Inflation**  
**(All Costs in Thousands of Dollars)**

	Alternative B	Alternative C	Alternative D	Alternative E
1. Total PV of new investment (i.e., funding requirements) from Tables 6, 8, 10, and 12	2,750	2,950	9,790	13,100
2. Plus value of existing assets to be employed on the project	-0-	-0-	-0-	-0-
3. Less value of existing assets replaced	-0-	-0-	-0-	-0-
4. Less discounted terminal value of new investment*	90	97	322	431
5. Total new PV of investment	2,660	2,853	9,468	12,669
6. PV of cost savings from operations, from Tables 7, 9, 11, and 13	6,140	5,790	21,400	40,100
7. PV cost of least investment alternative (Table 4)	5,470	5,470	5,470	5,470
8. Differential savings for test alternatives (line 6 plus 7)	11,610	11,260	26,870	45,570
9. Plus PV of the cost of refurbishment or modifications eliminated	-0-	-0-	-0-	-0-
10. Total PV of savings	11,610	11,260	26,870	45,570
11. SIR (line 10 divided by line 5)	4.36	3.95	2.84	3.60
12. Years to payback	4.7	5.3	6.5	5.0

\* The terminal value is assumed to be 10 percent of the first cost (line 1) inflated at 5%/yr (a multiplier of 3.39) times the 25-yr discount factor of 0.097. For example, for Alternative B, line 4 =  $2,750 \times 0.1 \times 3.39 \times 0.097 = 90$ .

Table 17

Summary of Characteristics of Solid Waste Disposal Alternatives

Alternative	Description of Alternative Systems*	Percent of Fort Dix FY76 Heating Load	Capital Investment (\$)	Energy-to-Cost Ratio (Million Gal Fuel Oil Conserved/yr)	Years to Payback (SIR)
A	Present practice: sanitary landfill, 18,600 tons of solid waste/yr at Fort Dix.	NA	0	NA	NA
B	Military resource-recovery facility (RRF): five package incinerators to recover energy from 18,600 tons of military solid waste (MSW)/yr; operating capacity of 21,000 lb of steam/hr.	9.7	2,750,000	57.3 (1.05)	4.7 yr (4.36)
C	Military RRF: one field-erected boiler to recover energy from 18,600 tons of MSW/yr; operating capacity of 21,000 lb of steam/hr.	10	2,950,000	55.9 (1.10)	5.3 yr (3.95)
D	Regional RRF: three field-erected boilers to recover energy from 52,100 tons/yr of military and civilian solid waste; operating capacity of 50,000 lb of steam/hr.	21	9,790,000	35.2 (2.30)	6.5 yr (2.84)
E	Regional RRF: as above except capacity of 73,900 tons/yr of solid waste and an operating capacity of 75,000 lb of steam/hr.	35	13,100,000	42.7 (3.73)	5.0 yr (3.60)

\* Each energy-recovery alternative (B through E) operates 24 hr/day, 6 days/wk.

Metals recovery and energy recovery from incineration of civilian wastes from nearby communities and wastes generated at Fort Dix and McGuire AFB are technically and economically feasible (Alternatives D and E).

2. The most cost-effective, technically feasible solid waste management alternative is Alternative B, with a 9.7 percent saving in annual energy consumption. Alternative B involves energy recovery from the combined solid waste streams of Fort Dix and McGuire AFB at Boiler Plant 5881, using a newly constructed incinerator plant containing five package-type controlled-air incinerator/boilers. Alternative B recovers energy from waste but not metals; once the metals have entered the waste stream, they cannot be economically recovered at a waste generation rate of 18,600 tons/year. Metals could be recycled by source separation, as noted in Appendix B. The potential fuel oil savings is 1.05 million gal/year. The capital investment required is \$2.75 million (in FY80 dollars), the PV saving is \$6.14 million, the SIR ratio is 4.36/1.00, and the number of years to pay back the investment is 4.7. The energy-to-cost ratio is 57.3.

3. The second most cost-effective solid waste management alternative is Alternative C, which involves energy recovery from the combined waste of Fort Dix and McGuire AFB at Boiler Plant 5881 using a newly constructed incinerator plant consisting of one field-erected, waterwall incinerator. The capital investment is \$2.95 million, the PV savings is \$5.79 million, the SIR ratio is 3.95/1.00, and the number of years to pay back the investment is 5.3. The energy-to-cost ratio is 55.9.

4. Alternative E is the most favorable method from a fuel oil conservation standpoint, with a 35 percent saving in annual energy consumption. It involves energy recovery from the combined solid waste streams from nearby civilian communities and those of Fort Dix and McGuire AFB. This alternative would be a newly constructed facility with three field-erected waterwall boilers. Ferrous metals in the amount of 2670 tons/year would be recycled. Alternative E would conserve 35 percent of Fort Dix's total annual heating load, or 3.73 million gal of fuel oil. Although it is the third ranked alternative from a cost-effective standpoint, it has an SIR of 3.60/1.00. The capi-

tal investment required is \$13.1 million in FY80 dollars, the PV savings is \$40.1 million, and the number of years to pay back is 5.0. The energy-to-cost ratio is 42.7.

5. Continuation of landfilling of Fort Dix and McGuire AFB wastes at Fort Dix landfill (Alternative A) is an acceptable procedure, but is more costly than energy-recovery incineration. Alternative A has an annual cost of \$445,000 in FY77 dollars, while the alternatives described above would result in savings.

6. The break-even point for a shredder for construction demolition lumber is 416 tons/year for Alternatives B and C. Shredders are required as part of Alternatives D and E.

7. Data from the weigh survey and national average waste characterization were sufficient for the economic analysis, but are not adequate for engineering design calculations.

8. Fort Dix should not use incinerator residue as a road construction material. As discussed in Appendix B, highway research concludes that use of incinerator residue is in the experimental stage, and not proven to be an acceptable or economic material.

#### Recommendations

1. A resource-recovery facility should be constructed adjacent to Boiler Plant 5881.

2. The resource-recovery facility should either recover energy from Fort Dix and McGuire AFB waste (Alternative B) or recover energy and metals from a combined military and civilian waste stream (Alternative E). Both alternatives are cost effective. Fort Dix may elect either the least-investment alternative (Alternative B) or the most fuel-conservative energy-recovery alternative (Alternative E) and achieve payback in less than 5 years. It is therefore recommended Fort Dix prioritize fuel savings vs project cost and implement the energy-recovery system which best responds to these priorities.

3. Incombustibles such as concrete, sand, steel from construction/demolition, and oversized bulky items, "self-help" disposals, and incinerator residue should continue to be landfilled at Fort Dix.

4. Metal recycling should only be incorporated in Alternative E, the energy-recovery incinerator plant which uses both military waste (Fort Dix and McGuire AFB) and civilian waste from the surrounding communities. Metal recycling would not be cost-effective in the other alternatives.

5. If either Alternative B or C is funded, investigations should be undertaken to determine site-specific design data (i.e., tons of waste per day and heating value of the waste) and whether sufficient construction demolition lumber will be available to make incorporation of a shredder cost effective.

6. If Alternative E is selected, a formal agreement should be made with the civilian solid waste management representatives to assure delivery of appropriate quantities and quality of solid waste. Note: because this agreement may have to conform to AR 420-41, any supporting information should emphasize that the primary mission of the resource-recovery facility is to recover energy from waste and provide that energy to Fort Dix; the secondary mission of the resource-recovery facility is to reduce waste to ash. Emphasis should be placed on the fact that civilian waste would be a resource to Fort Dix. AR 420-14 should be consulted when preparing the difficult technical portions of sales contracts, purchase contracts, and memoranda of understanding which would describe the quality of waste which is acceptable.

#### REFERENCES

- Brink, J. A., *Industrial Engineering and Chemistry*, vol 50, (1958), pp 654-8.
- Building Construction Cost Data* (Robert S. Means Co., Inc., 1976).
- Decision-Makers Guide in Solid Waste Management*, EPA Guide SW-500, (Environmental Protection Agency, 1976) Table 36, p 96.
- Economic Analysis and Program Evaluation for Resource Management*, AR 11-28 (Department of the Army, 1975).
- Empirical Cost Estimates for Military Construction and Cost Adjustment Factors*, AR 415-17 (Department of the Army, 1975).
- Incinerator Standards* (Incinerator Institute of America, 1970).
- Incinerators*, TM 5-814-4 (Department of the Army, 1959), para 8, p 3.
- Land Disposal of Solid Waste Operational Plan* (Fort Dix, NJ).
- Levy, S. J., and S. A. Lingle, "A Review of Energy Recovery Technologies," *Waste Age* (November 1976), p. 26.
- Municipal Incineration - A Review of Literature*, No. AP-79 (Environmental Protection Agency, 1971), Appendix.
- Niessen, W. R., and S. H. Chansky, "The Nature of Refuse," *Proceedings of the 1970 Incinerator Conference* (American Society of Mechanical Engineers,

1970) pp 1-24.

*Process Plant Construction Estimating and Engineering Standards* (Richardson Engineering Services, Inc., 1973).

Reese, R. G., *The Application of Dry Scrubbers to Waste-Wood-Fired Boilers*, presented at Forest Products Research Society meeting, 3 September 1975. *Revised Energy Conservation Investment Program (ECIP)*, Directorate of Facilities Engineering (OCF), Utilities Branch (April 1975).

Ross Hoffman Associates, *Evaluation of Small Modular Incinerators in Municipal Plants*, SW-113C (Environmental Protection Agency, 1976).

*Utilities Contract*, AR 420-41 (Department of the Army, 1976).

*Waste Materials as a Potential Replacement for Highway Aggregates*, Report 166 (National Cooperative Highway Research Program, 1976).

## APPENDIX A: SELECTION OF INCINERATOR PLANT LOCATION AND CALCULATION OF FUEL AND OPERATION AND MAINTENANCE SAVINGS

### Description of Locations

Boiler Plant 5881 is located on New Jersey Avenue between a motor repair shop on the west and a duck pond on the east. A barracks complex is located across New Jersey Avenue to the north and NCO family housing is located south of the boiler plant. The existing sanitary landfill is approximately 1.1 miles away via New Jersey Avenue, Pemberton Pointville Road, and Browne Mills Road; disposal of ash and bulky noncombustible waste from this location is therefore relatively easy.

Boiler Plant 5426 is located on Avenue C just off south Scott Plaza. The NCO Open Mess and swimming pool are to the west, an open area is to the north, the Service Club is to the east, and Higgs Folly Pond is to the south. Boiler Plant 5426 is more centrally located with respect to waste collection than Boiler Plant 5881, but the existing landfill is 3.0 miles away. This location is not acceptable to the Fort Dix Facility Engineering personnel as a site for a resource-recovery facility. Therefore, no further consideration was given to this location.

Laundry Boiler Plant 5324 is located south of the post laundry between Annex Road and Reception Avenue in what is considered to be the industrial area of Fort Dix.

Sufficient space for an incinerator plant is available

adjacent to each of the boiler plants, but each location offers a different potential fuel oil--and therefore cost--savings.

### Determination of Design Capacity

To determine the fuel oil savings at each location, the design capacity of the proposed plant must first be established. TM 5-814-4 requires that capacity be provided for 25 percent over the average hourly needs.<sup>7</sup> Table A1 shows the basic data required to find the design capacity of a proposed incinerator plant to operate 24 hrs/day, 6 days/week.

Table A1

#### Data Used in Calculating Design Capacity

Item	Value	Source
Design factor	1.25	TM 5-814-4
Avg weekly Fort Dix refuse	204 tons/wk	Table 2
Avg daily Fort Dix refuse	42.7 tons/day	Table 1
Avg daily Fort Dix and McGuire AFB refuse	74.9 tons/day	Table 1
Days operation/wk	6	--
Hours operation/day	24	--

The tonnage per week for the combined Fort Dix and McGuire AFB waste stream is not given in Table A1. It can be calculated as being proportional to the weekly Fort Dix refuse:

$$\frac{\text{Avg Fort Dix/McGuire AFB weekly refuse}}{\text{Avg Fort Dix/McGuire AFB daily refuse}} = \frac{\text{Avg weekly Fort Dix refuse}}{\text{Avg daily Fort Dix refuse}}$$

$$\text{Avg Fort Dix/McGuire AFB weekly refuse} = \frac{74.9 \times 204}{42.7} = 357.8 \text{ tons}$$

The design capacity can then be calculated as:

$$\begin{aligned} \text{Design capacity} &= \frac{1.25 \times 357.8 \text{ tons/week}}{6 \text{ days/week}} \\ &= 74.55 \text{ tons/day or } 3.11 \text{ tons/hr} \end{aligned}$$

<sup>7</sup>*Incinerators*, TM 5-814-4 (Department of the Army, 1959), para 8, p 3.

The energy available from refuse on an annual basis is:

$$\begin{aligned} \text{Annual energy} &= 357.8 \text{ tons/week} \times \\ & 2000 \text{ lb/ton} \times 52 \text{ weeks/year} \times \\ & 5740 \text{ Btu/lb} \\ &= 21.35 \times 10^{10} \text{ Btu/year} \end{aligned}$$

However, for economic calculations, the average of 74.55/1.25 or 59.64 tons/day was used with the heating value of 5740 Btu/lb (Table 3).

#### Fuel Savings Using Package Incinerator

The amount of steam available from a package incinerator burning refuse plus auxiliary fuel can be computed as:

$$\begin{aligned} \text{Steam available} &= \\ & \frac{5740 \text{ Btu/lb} \times 2000 \text{ lb/ton} \times 59.64 \text{ tons/day} \times 0.7 \times 1.06}{24 \text{ hr/day} \times (1189.7 - 147.9) \text{ Btu/lb}} \\ &= 20,300 \text{ lb steam/hr} \end{aligned}$$

where

0.70 = assumed efficiency of package incinerator/boiler  
1.06 = factor to include heat value of auxiliary fuel  
1189.7 Btu/lb steam = outlet conditions for 100-psig steam  
147.9 Btu/lb feed water = assumed inlet conditions at 180° F.

Since the steam available from package incinerators is less than the average steam production each month (see Table A2), the "efficiencies" calculated the volume of the oil potentially saved by each alternative.

#### Alternative B

The oil potentially saved by a package incinerator adjacent to Boiler Plant 5881 would be:

$$\begin{aligned} & \frac{20,300 \text{ lb/hr} \times 24 \text{ hr/day} \times 5.66 \text{ days/week} \times 52 \text{ weeks/year}}{128.5 \text{ lb steam/gal oil} \times 1.06} \\ &= 1,050,000 \text{ gal/year} \end{aligned}$$

#### Alternative C

The steam available from a field-erected incinerator can be calculated as:

$$\begin{aligned} \text{Steam available} &= \\ & \frac{5740 \text{ Btu/lb} \times 2000 \text{ lb/ton} \times 59.64 \text{ tons/day} \times 0.75 \times 1.005}{24 \text{ hr/day} \times (1189.7 - 147.9) \text{ Btu/lb}} \\ &= 20,640 \text{ lb steam/hr} \end{aligned}$$

where

0.75 = assumed efficiency of field-erected boiler  
1.005 = factor to include heat value of auxiliary fuel  
1189.7 Btu/lb steam = outlet conditions  
147.9 Btu/lb feed water = assumed inlet conditions.

The oil potentially saved by a field-erected incinerator adjacent to Boiler Plant 5881 would be:

$$\begin{aligned} & \frac{20,640 \times 24 \text{ hr/day} \times 5.66 \text{ days/week} \times 50 \text{ weeks/year}^*}{128.5 \text{ lb steam/gal oil} \times 1.005} \\ &= 1,100,000 \text{ gal oil/year} \end{aligned}$$

#### Alternatives D and E

See Tables A3 and A4.

#### Summary

Table A5 summarizes the fuel savings for Alternatives B, C, D, and E. Also see Table A6.

\* Assume 2 weeks scheduled maintenance per year.

Table A2

Boiler Plant 5881,  
Average Monthly Steam Production and Efficiency\*

Month	Oil Used (gal × 10 <sup>3</sup> )	Total Steam (lb × 10 <sup>3</sup> )	Average Production (lb/hr)
Dec 74	389.5	44.98	60,500
Jan 75	438.4	50.37	67,700
Feb 75	367.4	41.89	62,400
Mar 75	314.0	43.78	58,800
Apr 75	279.3	37.52	52,100
May 75	203.4	24.58	33,000
Jun 75	135.9	18.61	25,900
Jul 75	158.6	22.14	29,800
Aug 75	148.9	20.89	28,100
Sep 75	148.4	20.97	29,100
Oct 75	183.6	26.21	35,200
Nov 75	283.4	40.24	55,900
Totals	3,050.8	392.10	

\* "Efficiency" of Boiler Plant 5881 =  
 $\frac{392.1 \times 10^6}{3050.8 \times 10^3} = 128.5 \text{ lb steam/gal oil}$

**Table A3**  
**Steam Load and Steam Available From Waste, Alternatives D and E**  
**(Average Pounds Steam in Thousands/Hr)**

Month	Steam Load		Steam From Waste *	
	Bldg 5252 & 5881	Bldg 5252, 5881, & 5428	Alternative D (50,000 lb/hr)	Alternative E (75,000 lb/hr)
July 75	39.0	72.3	31.2	57.8
Aug	36.6	67.6	29.3	54.1
Sep	38.4	65.8	30.7	52.6
Oct	44.0	78.8	35.2	63.0
Nov	70.7	128.5	50.0	75.0
Dec	94.2	165.7	50.0	75.0
Jan 76	113.1	201.6	50.0	75.0
Feb	104.6	184.4	50.0	75.0
Mar	90.9	163.2	50.0	75.0
Apr	98.0	156.3	50.0	75.0
May	55.8	99.9	44.6	75.0
Jun	38.0	75.5	30.4	60.4
Total		1459.6	501.4	812.9
avg/month		121.6	41.8	67.7

\* lb of steam/yr: present system =  $121.6 \times 10^3 \times 24 \text{ hr/day} \times 365 \text{ days/yr} = 1066 \times 10^6$   
 lb of steam/yr: Alt D =  $41.8 \times 10^3 \times 24 \text{ hr/day} \times 5.66 \text{ days/week} \times 52 = 295.5 \times 10^6$   
 lb of steam/yr: Alt E =  $67.7 \times 10^3 \times 24 \text{ hr/day} \times 5.66 \text{ days/week} \times 52 = 478.7 \times 10^6$

**Table A4**

**Fuel and O&M Savings for Alternatives D and E**

Given: Alternative D produces =  $295.5 \times 10^6$  lb steam/yr (Table A3)  
Alternative E produces =  $478.7 \times 10^6$  lb steam/yr (Table A3)  
Cost to produce =  $10^6$  lb steam/yr at Fort Dix \$840\*  
Boiler Plant 5881 produces = 128.5 lb steam/gal oil (Table A2)

Alternative D--Fuel credit

$$\frac{295.5 \times 10^6 \text{ lb steam/yr}}{128.5 \text{ lb steam/gal oil}} = 2.30 \times 10^6 \text{ gal oil/yr}$$

Alternative D--O&M credit

$$295.5 \times 10^6 \text{ lb steam} \times \$840 / 10^6 \text{ lb steam} \times 1.07 = \$265,600 \text{ (FY77)}$$

Alternative E--Fuel credit

$$\frac{478.7 \times 10^6 \text{ lb steam/yr}}{128.5 \text{ lb steam/gal oil}} = 3.73 \times 10^6 \text{ gal oil/yr}$$

Alternative E--O&M credit

$$478.7 \times 10^6 \text{ steam} \times \$840 / 10^6 \text{ lb steam} \times 1.07 = \$402,000 \text{ (FY77)}$$

\*Fiscal records revealed that the cost to operate and maintain Boiler Plants 5252, 5426, and 5881 was \$840 per  $10^6$  lb of steam produced in FY76, excluding fuel costs.

**Table A5**

**Summary of Alternatives**

Alternative	Oil Saved/Yr in Gal
B	1,050,000
C	1,100,000
D	2,300,000
E	3,730,000

**Table A6**  
**Laundry Boiler Plant 5324,**  
**Projected Average Monthly Steam Production**

This table provides the data used to plot the laundry plant curve on Figure 2. The average monthly steam production was projected from annual fuel consumption and daily steam production data for the family housing area proposed to be supported by Boiler Plant 5324 on a 24 hr/day, 6 days/wk basis, and the laundry facility to be supported 8 hr/day, 5 days/wk.

Month (1976)	COLUMN A	COLUMN B	COLUMN C
	Steam for Family Housing (lb × 10 <sup>3</sup> )	Steam for Laundry Plant (lb × 10 <sup>3</sup> )	Total Steam Sum Col A + Col B (lb × 10 <sup>3</sup> )
Jan	10.62	4.48	15.10
Feb	8.79	3.10	11.89
Mar	9.49	5.74	15.23
Apr	8.79	2.98	11.77
May	6.62	2.63	9.25
Jun	4.79	2.92	7.71
Jul	5.14	2.40	7.54
Aug	4.79	2.27	7.06
Sep	4.09	2.97	7.06
Oct	5.40	2.74	8.14
Nov	8.70	2.61	11.31
Dec	9.84	3.72	13.56

**APPENDIX B:**  
**POTENTIAL VALUE OF RECYCLABLE**  
**MATERIALS AT FORT DIX**

**Value of Recoverable Ferrous Metal and Aluminum**

The annual amount of waste collected from the waste stream at Fort Dix was computed using the 204 tons/week generation rate from Table 2:

$$204 \text{ tons/week} \times 52 \text{ weeks/year} = 10,600 \text{ tons/year}$$

The value of recoverable ferrous metal and aluminum in the waste stream was calculated by applying the following assumed fractions and values\* to the annual waste generation rate.

1. Fraction of ferrous metal in waste stream: 0.038\*\*
2. Fraction of aluminum in waste stream: 0.007<sup>a</sup>

\* Based on Defense Property Disposal data for part of the calendar year 1976.

\*\*Based on data from Charleston, SC, shredder facility. The facilities would have similar input restraints.

<sup>a</sup> *Decision-Makers Guide in Solid Waste Management*, EPA Guide SW-500 (Environmental Protection Agency [EPA]), Table 36, p 96.

3. Fraction of ferrous metal recoverable: 0.95
4. Fraction of aluminum recoverable: 0.6
5. Estimated value of ferrous metals: \$26.70/ton
6. Estimated value of aluminum: \$165/ton.

The value of recoverable ferrous metal was determined to be:

$$0.038 \times 0.95 \times 10,600 \text{ tons/year} \times \$26.70/\text{ton} = \$10,220/\text{year}$$

The value of recoverable aluminum was found to be:

$$0.007 \times 0.6 \times 10,600 \text{ tons/year} \times \$165/\text{ton} = \$7,345/\text{year}$$

The amount of ferrous recoverable in Alternatives D and E waste stream are calculated as follows.

Alternative D:

$$0.038 \times 0.95 \times 52,100 \text{ tons/year} = 1,880 \text{ tons/year}$$

Alternative E:

$$0.038 \times 0.95 \times 73,900 \text{ tons/year} = 2,670 \text{ tons/year}$$

**Methods of Separating Aluminum From Waste**

There is no known economical method for separating aluminum from the waste stream when it is present in the amounts estimated in the preceding paragraphs. If this relatively low level of metals is to be recycled, the method suggested is separation at the source. Containers with highly visible signs should be located at the source of the

metals; for example, containers for beer and soft drink cans should be placed at the Post Exchange Cafeteria. The containers would be emptied regularly, and the metal sold through the Defense Property Disposal Office (DPDO). The DPDO should be contacted for a current or updated market analysis prior to any significant capital expenditure.

#### **Use of Incinerator Residue as a Road Construction Material<sup>9</sup>**

Waste materials have been divided into four classes on the basis of their potential for highway use. Class I material, which includes such wastes as blast furnace slag, reclaimed paving material, fly ash, bottom ash, boiler slag, and anthracite coal refuse, has maximum potential for such use. Incinerator residue is assigned to Class II, which includes materials either requiring more extensive processing or having less adequate properties than Class I materials. Class III and Class IV materials have less potential value than those in Class I or II.

Several cities have used incinerator residue in highway construction. Tampa, FL, is presently using incinerator residue for embankments. Chicago, IL, has used incinerator residue as an experimental base course composition, and Philadelphia, PA, has used it as an experimental bituminous paving.

All uses for incinerator residue in highway construction are currently experimental. Fort Dix should not consider using incinerator residue as a road construction material until incinerator residue is reported as an acceptable and economical material.

### **APPENDIX C: METHOD OF ECONOMIC ANALYSIS AND BASIS OF CAPITAL COST ESTIMATE FOR RECOMMENDED ENERGY- RECOVERY SYSTEMS**

#### **General**

The general method of economic analysis follows guidance set forth in AR 11-28.<sup>10</sup> The present value (PV)

<sup>9</sup>Waste Materials as a Potential Replacement for Highway Aggregates, Report 166 (National Cooperative Highway Research Program, 1976).

<sup>10</sup>Economic Analysis and Program Evaluation for Resource Management, AR 11-28 (Department of the Army, 1975).

method is used to calculate the investment, annual, and total costs of a project over an economic life of 25 years in terms of current dollars. For annually recurring costs, the method considers inflation rates associated with individual operation and maintenance (O&M) cost elements and a 10 percent interest rate.

In the cost evaluation of the alternatives, each candidate project is considered alone. The costs associated with each energy-recovery system are the costs associated with the complete waste management system of which it is an integral part. A system's economic considerations include all activities from waste generation to disposal of ash and residue and the use of generated steam. Capital, annual, and total PV costs of an energy-recovery system may be greater or less than those costs associated with the current waste management system.

An energy-recovery system will often reduce or eliminate O&M or capital costs incurred under the current system. Increased capital expenditures normally required in energy-recovery systems are treated as debits, or costs. In the economic analysis of energy-recovery systems, relatively substantial credits occur for avoided costs. For example, when steam is derived from combustion of wastes in an energy-recovery system, a comparable quantity of fuel oil (or, in general terms, clean fuel) does not have to be used. The avoided PV cost of displaced fuel oil hence appears as a credit in the economic analysis of the system.

When costs for all candidate systems have been established, a summary economic comparison is made according to procedures set forth in AR 11-28. Candidate waste management alternatives are compared to the least investment cost alternative, and their respective savings/investment ratios (SIRs) determined. The recommended waste management alternative is usually chosen by economic judgment, based on the SIR, and magnitude of required investment. Frequently, however, an alternative waste management system with relatively unattractive economic aspects may be recommended for reasons other than economic (i.e., legal, environmental, political, anticipated mission changes, etc.).

#### **Information Sources**

Current procurement, installation, and construction costs are obtained from manufacturers and vendors whenever possible during contacts to obtain performance characteristics and equipment specifications for capital required in an energy-recovery system. Sources of investment cost information include Mean's *Building Construction Cost Data*, Richardson's *Process Plant Construction Estimating and Engineering Standards*, and

AR 415-17.<sup>11</sup> Investment costs tabulated for each candidate waste management alternative are installed costs. To develop a budget estimate for an alternative's total capital requirements, the sum of the installed capital cost is increased both by a location factor to account for regional economic differences, and by a technological updating factor. Each item of cost includes the contractor's profit and contingency.

Manufacturers and vendors normally provide O&M requirements. In cases when O&M information is not available from hardware sources, the engineering references cited above are used. Utilities costs are provided by the Facility Engineer at the site for which the study is being executed. When possible, local labor costs are used. When local labor costs are not readily available, labor costs tabulated in Table C1 are used. To determine the true cost of a worker to the employer, the costs used include 1.296 times the employee's annualized hourly wage (to account for overhead, benefits, etc.)

#### APPENDIX D: ECONOMIC MERITS OF A SHREDDER

The following discussion applies only to Alternatives B

<sup>11</sup> *Building Construction Cost Data, 1976* (Robert S. Means Co., Inc., 1976); *Process Plant Construction Estimating and Engineering Standards* (Richardson Engineering Services, Inc., 1973); *Empirical Cost Estimates for Military Construction and Cost Adjustment Factors, AR 415-7* (Department of the Army, 1975).

and C. During the limited survey, 2.6 tons/day of lumber from construction demolition was landfilled. The lumber is segregated at the source and could easily be diverted to an incinerator plant. However, the lumber would have to be shredded to be effectively incinerated.

The shredder considered for use at Fort Dix is a low-capacity (nominal 4 tons/hr), low speed (12 rpm), and low horsepower (40 hp) model. It is intended for use on pallets, crates, and construction/demolition only. It should not be confused with the 40 tons/hr, 1000 rpm, 500 hp shredders often used to shred refuse.

The following economic analysis was made to determine whether a shredder would be cost effective. The analysis was performed for two situations: 2.6 tons/day lumber for 100 days/year, and 2.6 tons/day for 200 days/year. A constant dollar analysis was made first. The capital investment for a shredder is \$70,000, the maintenance \$3,500/year and the cost of required electricity \$155/year. The fuel value of the shredded wood for the situation in which lumber is available 100 days/year was calculated as:

$$\frac{100 \text{ days/year} \times 2.6 \text{ tons/day} \times 4780 \text{ Btu/lb} \times 2000 \text{ lb/ton} \times 0.7}{1100 \text{ Btu/lb steam} \times 122 \text{ lb steam/gal oil}}$$

$$= 12,900 \text{ gal/year.}$$

At \$0.36/gal, the value of this fuel savings would be \$4644/year. Based on this amount, the PV was calculated to be:

$$\$4644 - (3500 + 155) = 989 \times 8.933 = \$8835$$

Table C1

#### Labor Costs Used When Local Costs Are Unavailable

Job	Hourly Wage (\$)	Annual Wage (\$)	Cost to Employer (\$)
Plant manager	7.30	15,179	19,672
Shift supervisor	6.70	13,934	18,059
Weighmaster	4.04	8,409	10,898
Crane operator	4.95	10,287	13,332
Shredder operator	4.64	9,654	12,511
Maintenance personnel	4.95	10,287	13,332
Helper/laborer	3.44	7,164	9,284
Ash handler	3.75	7,797	10,105
Front-end loader operator	5.25	10,920	14,153
Boiler operator	4.95	10,287	13,332
Asst boiler operator	4.64	9,654	12,511
Stoker operator	4.64	9,654	12,511
Service personnel	4.40	9,151	11,860
Truck driver	5.29	11,003	14,261
Dozer operator	4.96	10,137	13,371
Landfill operator	4.64	9,654	12,511

Thus, under these circumstances, the shredder would have a PV cost of \$61,165 (\$70,000 - \$8835).

If the lumber is available 200 days/year, the PV would be twice as much, or \$17,669. Based on constant dollars, the shredder would have a PV cost of \$52,301 (\$70,000 - \$17,699).

Tables D1, D2, and D3 were developed using the inflation rates discussed in Chapter 4. The calculations in

Table D1 indicate that using a shredder for 2.6 tons/day of wood for 100 days/year is not cost effective, but incurs a loss of \$39,000 over the 20-year life of the shredder. Table D2 indicates that using a shredder for 2.6 tons/day of wood for 200 days/year is cost effective, resulting in a small savings of \$28,000 over the 20-year life of the shredder. The break-even point (shown in Table D3) would be approximately 2.6 tons/day for 160 days/year or 416 tons/year.

**Table D1**  
**PV of Proposed Shredder With Lumber**  
**From Construction Demolition Available 100 Days/Year**

Project Year (CY76)	COLUMN A	COLUMN B	COLUMN C	COLUMN D	COLUMN E
	O&M (\$)	Fuel Credit (\$)	Annual Cost, Col A - Col B (\$)	Discount Factor (\$)	PV Annual Cost, Col C × Col D (\$)
1	3,655	4,644	- 989	0.954	- 944
2	3,838	5,108	- 1,270	0.867	- 1,101
3	4,030	5,619	- 1,589	0.788	- 1,252
4	4,231	6,181	- 1,950	0.717	- 1,398
5	4,443	6,799	- 2,356	0.652	- 1,536
6	4,665	7,479	- 2,814	0.592	- 1,666
7	4,898	8,003	- 3,105	0.538	- 1,670
8	5,143	8,563	- 3,420	0.489	- 1,672
9	5,400	9,162	- 3,762	0.445	- 1,674
10	5,670	9,803	- 4,133	0.405	- 1,674
11	5,954	10,489	- 4,535	0.368	- 1,669
12	6,251	11,223	- 4,972	0.334	- 1,661
13	6,564	12,009	- 5,445	0.304	- 1,682
14	6,892	12,850	- 5,958	0.276	- 1,644
15	7,237	13,750	- 6,513	0.251	- 1,635
16	7,598	14,713	- 7,115	0.228	- 1,622
17	7,978	15,743	- 7,765	0.208	- 1,615
18	8,377	16,843	- 8,468	0.189	- 1,600
19	8,796	18,022	- 9,226	0.172	- 1,587
20	9,236	19,284	-10,048	0.156	- 1,567
			Sum of PV annual cost		-\$30,869

$$\begin{aligned} \text{PV savings} &= \text{Sum of PV annual savings} - \text{capital investment} \\ &= 30,869 - 70,000 = -\$39,131 \end{aligned}$$

**Table D2**

**PV of Proposed Shredder With Lumber  
From Construction Demolition Available 200 Days/Year**

Project Year (CY76)	COLUMN A	COLUMN B	COLUMN C	COLUMN D	COLUMN E
	O&M (\$)	Fuel Credit (\$)	Annual Cost. Col A - Col B (\$)	Discount Factor (\$)	PV Annual Cost. Col C x Col D (\$)
1	3,655	9,288	- 5,633	0.954	-5,374
2	3,838	10,217	- 6,379	0.867	-5,530
3	4,030	11,239	- 7,209	0.788	-5,680
4	4,231	12,363	- 8,132	0.717	-5,831
5	4,443	13,599	- 9,156	0.652	-5,970
6	4,665	14,959	-10,294	0.592	-6,094
7	4,898	16,006	-11,108	0.538	-5,976
8	5,143	17,126	-11,983	0.489	-5,860
9	5,400	18,325	-12,925	0.445	-5,752
10	5,670	19,608	-13,938	0.405	-5,645
11	5,954	20,981	-15,027	0.368	-5,530
12	6,251	22,450	-16,199	0.334	-5,410
13	6,564	24,022	-17,458	0.304	-5,307
14	6,892	25,704	-18,812	0.276	-5,192
15	7,237	27,503	-20,266	0.251	-5,087
16	7,598	29,429	-21,831	0.228	-4,977
17	7,978	31,489	-23,511	0.208	-4,890
18	8,377	33,693	-25,316	0.189	-4,785
19	8,796	36,052	-27,256	0.172	-4,688
20	9,236	38,576	-29,340	0.156	-4,577

Sum of PV annual cost **- \$98,401**

PV savings = Sum of PV annual savings - capital investment  
 = 98,401 - 70,000 = \$28,401

**Table D3**  
**PV of Proposed Shredder With Lumber**  
**From Construction Demolition Available 160 Days/Year**

Project Year (CY76)	COLUMN A	COLUMN B	COLUMN C	COLUMN D	COLUMN E
	O&M (\$)	Fuel Credit (\$)	Annual Cost, Col A - Col B (\$)	Discount Factor (\$)	PV Annual Cost, Col C x Col D (\$)
1	3,655	7,430	3,775	0.954	-3,602
2	3,838	8,173	4,335	0.867	-3,758
3	4,030	8,990	4,960	0.788	-3,909
4	4,231	9,889	5,658	0.717	-4,057
5	4,443	10,878	6,435	0.652	-4,196
6	4,665	11,966	7,301	0.592	-4,332
7	4,898	12,803	7,905	0.538	-4,253
8	5,143	13,700	8,557	0.489	-4,184
9	5,400	14,658	9,258	0.445	-4,120
10	5,670	15,685	10,015	0.405	-4,056
11	5,954	16,782	10,828	0.368	-3,985
12	6,251	17,957	11,706	0.334	-3,910
13	6,564	19,214	12,650	0.304	-3,846
14	6,892	20,559	13,667	0.276	-3,772
15	7,237	21,998	14,761	0.251	-3,705
16	7,598	23,538	15,940	0.228	-3,634
17	7,978	25,186	17,208	0.208	-3,579
18	8,377	26,949	18,572	0.189	-3,510
19	8,796	28,835	20,039	0.172	-3,447
20	9,236	30,854	21,618	0.156	-3,372
				Sum of PV annual cost	<u>- \$77,227</u>

PV savings = Sum of PV annual savings - capital investment  
 = 77,227 - 70,000 = \$7,227

## APPENDIX E: THE APPLICATION OF DRY SCRUBBERS TO WASTE-WOOD-FIRED BOILERS\*

### Introduction

The Dry Scrubber is a new and unique application for granular filtration recently introduced to the gas cleanup field. It removes particulate from the gas stream in a dry form, utilizing a moving bed of filtering media, and, in so doing, is self-cleaning while operating on a continuous basis.

### Description

Conceptually, and as shown in Figure E1, the system consists of a cylindrical vessel containing two concentric, louvered, cylindrical tubes. The annular space between the tubes is filled with pea-sized gravel media. The particulate-laden exhaust gases enter the filter through appropriate breeching and are distributed to the filter face by the plenum section formed between the outer louvered cylinder and the vessel wall. Dirty gases pass through the filter media at velocities ranging from 100 to 150 ft/min (depending on the size of the particulate to be removed), and the particulate is removed from the gas stream by impaction with the media. Cleaned gases exit to downstream breeching or to the atmosphere through the exhaust duct formed by the extension of the inner louvered tube.

To prevent a filter cake from forming on the face of the filter, and the resulting potential plugging problems and high pressure drop, the filtering media are continuously, but slowly (1 to 4 ft/hour), moved downward in plug flow. The resulting churning action across each louver opening prevents a filter cake from forming. To provide complete cleaning of the louver face, the louvers are designed so that some of the media are pushed through each louver opening, thus preventing any bridging and buildup of particulate material.

The particulate-laden media are continuously removed at the bottom of the Dry Scrubber where they are cleaned and transported to a bucket elevator by action of a vibrating feeder/screener. The cleaned media are then conveyed to the top of the Dry Scrubber and via gravity feed are returned to the unit for recycling.

\* Condensed from a paper presented by R.G. Reese, Vice Pres & Gen Mgr. Commercial Div. Combustion Power Co. Inc., Forest Products Research Society Meeting, 3 September 1975, Denver, CO.

### Operation

Impaction is the Dry Scrubber's principle of operation and can best be described by referring to the operation of the cascade impactor measuring instrument used by the EPA, other regulatory organizations, and testing laboratories to measure the size distribution of particulate in gas streams. Figure E2 is a drawing of one type of cascade impactor which consists of a series, or cascade, of target plates. The particulate-laden exhaust gas to be sampled is directed to each plate through decreasing-sized nozzles or orifices. As the gas passes through each nozzle, it achieves a given velocity and, in seeking a path to the next nozzle, diverts around its target plate. A particulate of a given size, and larger, has too much momentum to make the turn and impacts on the target. As the gas passes through each succeeding nozzle, it is accelerated to higher and higher velocity and, consequently, smaller and smaller particulate impacts and is retained by each succeeding target. By choosing the proper size nozzles, the size of the particulate that is captured by each plate can be controlled within very close limits to measure very small particulate--well into the submicron range.<sup>12</sup>

The Dry Scrubber consists of a thick bed of pea-gravel type media and, as shown in Figure E3, can be envisioned as a great number of various-sized nozzles and target plates formed by individual clusters of rocks, each of which collects particulates by impaction.

The simplicity of design, the self-cleaning, moving-bed feature, and the stability and inertness of the filtering media and materials of construction of the Dry Scrubber make it insensitive to fluctuating operating conditions. It can operate efficiently over a wide range of gas flow rates and is tolerant of sparks, temperature excursions in excess of 750° F, chemical changes in the gas and particulate, condensation during cold startup, as well as other upset conditions often encountered in field operation.

### Efficiency

The moving bed feature of the Dry Scrubber makes it possible to adjust the efficiency, or output particulate loading, by simply regulating the filter media recirculation rate, or for even lower output dust loadings, changing the size of the inexpensive filtering media. Either of these changes can be accomplished on the unit "as-installed" without affecting operating capacity or changing exiting hardware. A minor change in operating fan horsepower will be required, however, to compensate for the slight increase in filter pressure drop.

<sup>12</sup>Brink, J. A., *Ind. Eng. Chem* 50 (1958) pp. 654-8.

**DRY SCRUBBER**  
(PATENT PENDING)

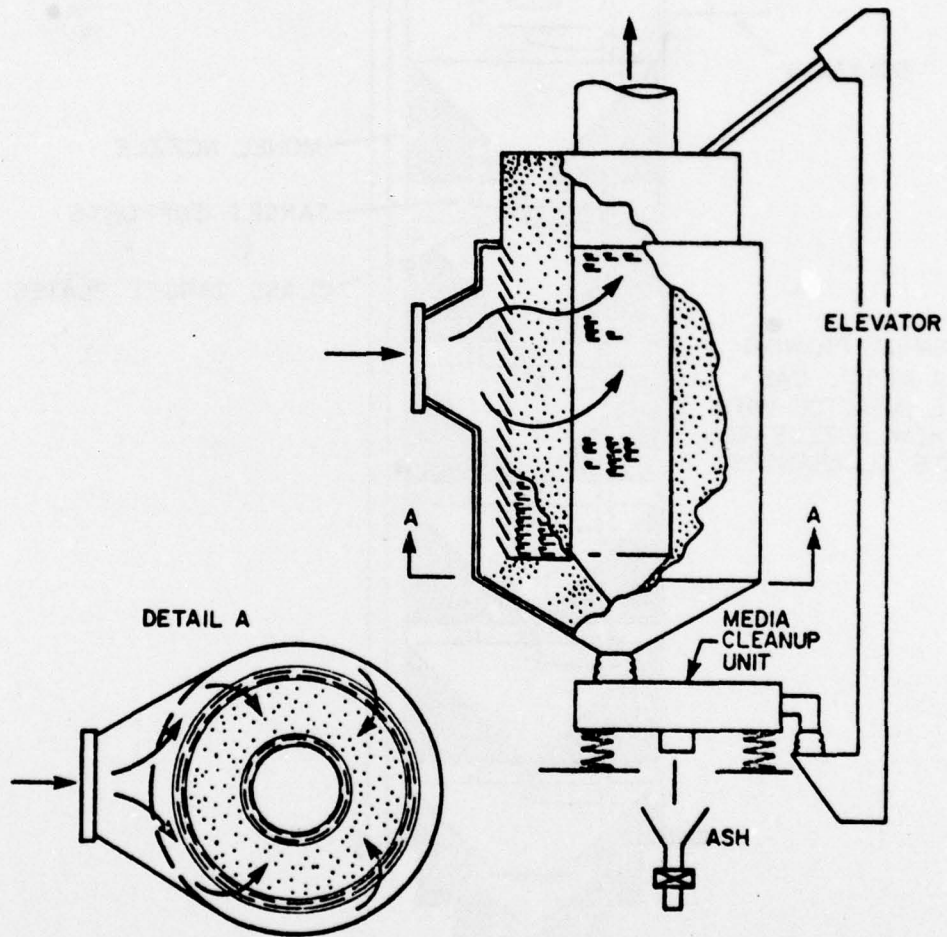

**COMBUSTION POWER COMPANY, INC.**   
1346 WILLOW ROAD, MENLO PARK,  
CALIFORNIA 94025

**Figure E1. Dry Scrubber.**

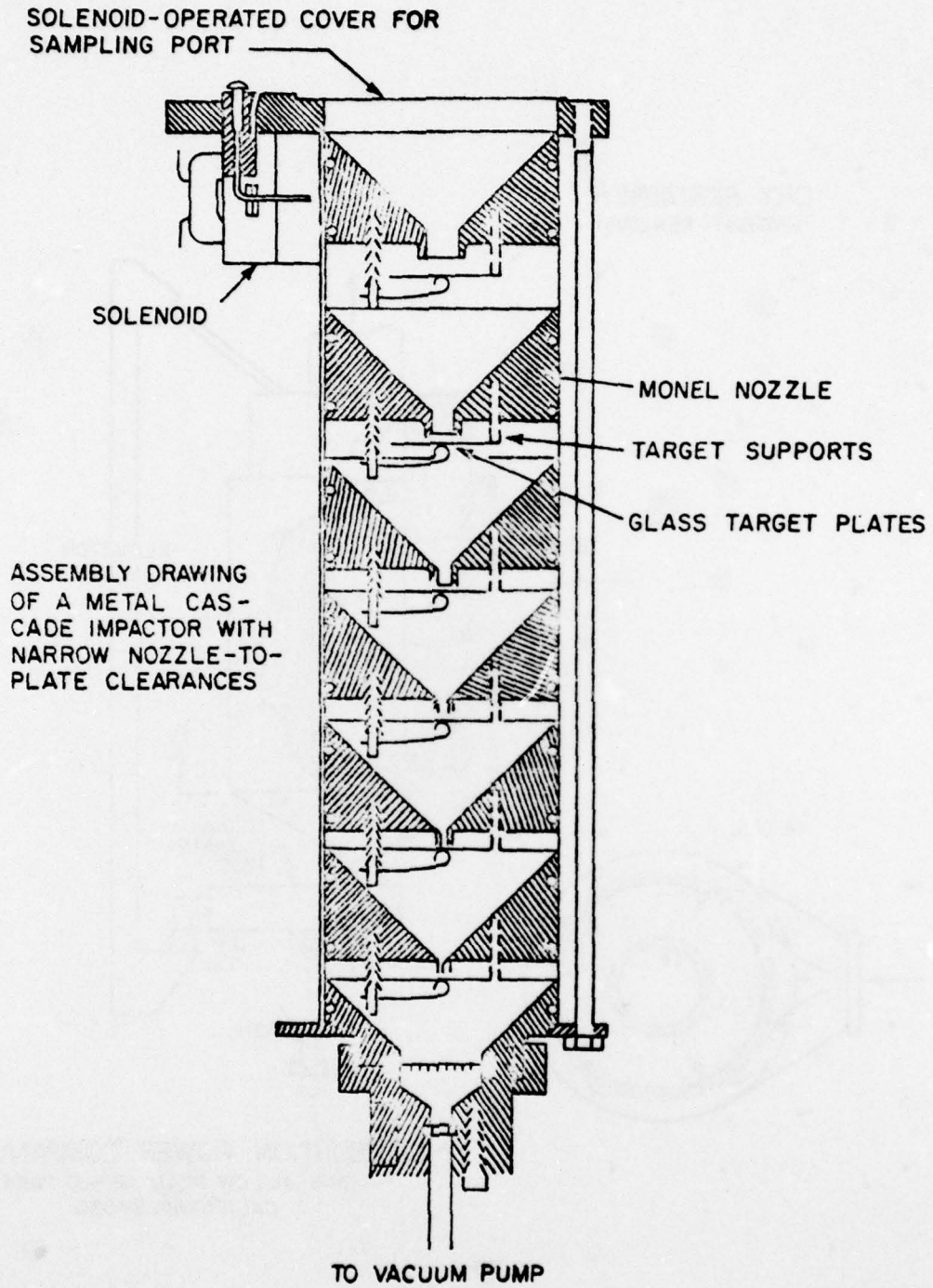

Figure E2. Cascade impactor.

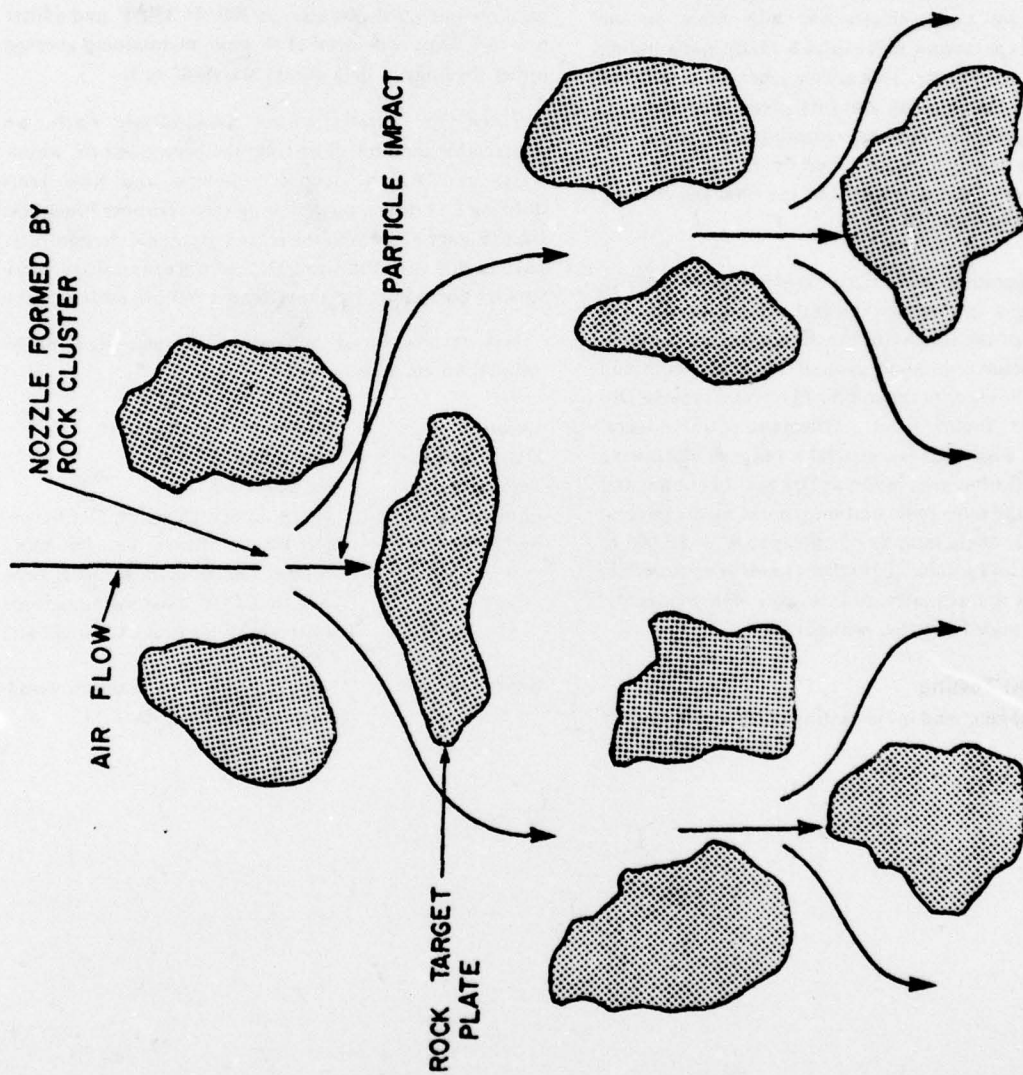

Figure E3. Diagram of rock filter-bed showing impact concept.

### **Integral Cyclone**

A study of waste-wood-fired boiler operation has shown there is heavy emission directly from the boiler, prior to any gas cleanup, and that a high percentage of the particulate constitutes coarse, frangible, carbonaceous material. Typical installations utilize high-efficiency mechanical collectors in the form of cyclones or multiclones. To achieve high efficiency, high gas velocities are required to generate high centrifugal forces. The combination of high velocity and high force on the particulate at the cyclone wall causes breakup and grinding of the coarse particulate. This action generates fines, thus compounding the emission and final cleanup problem. If this coarse material can be removed with minimum breakup, not only is it better suited for re-injection back into the boiler as a usable fuel, but the final gas cleanup problems will be reduced.

The configuration of the Dry Scrubber lends itself to incorporating a low energy integral cyclone around the outside wall of the Dry Scrubber, thus enabling common support structure, minimal ground area, and common breeching to be used for the combined integral cyclone Dry Scrubber unit. Figure E4 is a schematic of the integral cyclone unit, Figure E5 is a general arrangement drawing of an 800 sq ft filter area modular Dry Scrubber unit, and Figure E6 is the same basic unit incorporating the integral cyclone. Each of these units has a capacity of 80,000 to 100,000 acfm and will handle exhaust gases of up to 750° F. Smaller units are available and, to gain higher capacity, modules are added together without limit.

### **Development Testing**

The development and initial testing of the Dry Scrubber

unit was done at Combustion Power Company's (CPC) Menlo Park, CA, Research Center to solve a particle emission problem caused by the fluid bed combustors being operated by CPC. This development led to testing and the ultimate installation of a 365 sq ft Dry Scrubber unit at Weyerhaeuser Company's Snoqualmie Falls Lumber Mill, Snoqualmie Falls, WA. This system (Figure E7) has been in successful operation for more than one year, operating at a mean filter gas velocity of 150 ft/min, a gas flow rate of 55,000 acfm at 300° to 350° F, and a filter pressure drop of 5 in. of H<sub>2</sub>O while maintaining average outlet loadings of 0.05 gr/dry standard cu ft.

Since the installation at Snoqualmie Falls, an appreciable amount of testing has been done on wood-waste-fired boilers, recovery boilers, and lime kilns utilizing a portable, recirculating Dry Scrubber Field Test Unit (Figure E8). From the results of these tests, contracts have been let for full-sized Dry Scrubber installations by various companies for more than 1 million cu ft of gas.

Test results for a typical wood-waste-fired boiler installation are as follows:

Location:	Southeast United States
Date Tested:	January 1975
Test Data:	See Table E1
Equipment on Order:	3 each, Integral Cyclone Dry Scrubber Units, Model No. DS-800C, rated at 300,000 acfm at 750° F, to be used in place of existing multiclones upstream of air heat exchanger and I.D. fan.
Boiler Operation:	Moving grate. Combination wood-waste and fuel-oil fired.

**DRY SCRUBBER  
(WITH INTEGRAL CYCLONE)  
(PATENT PENDING)**

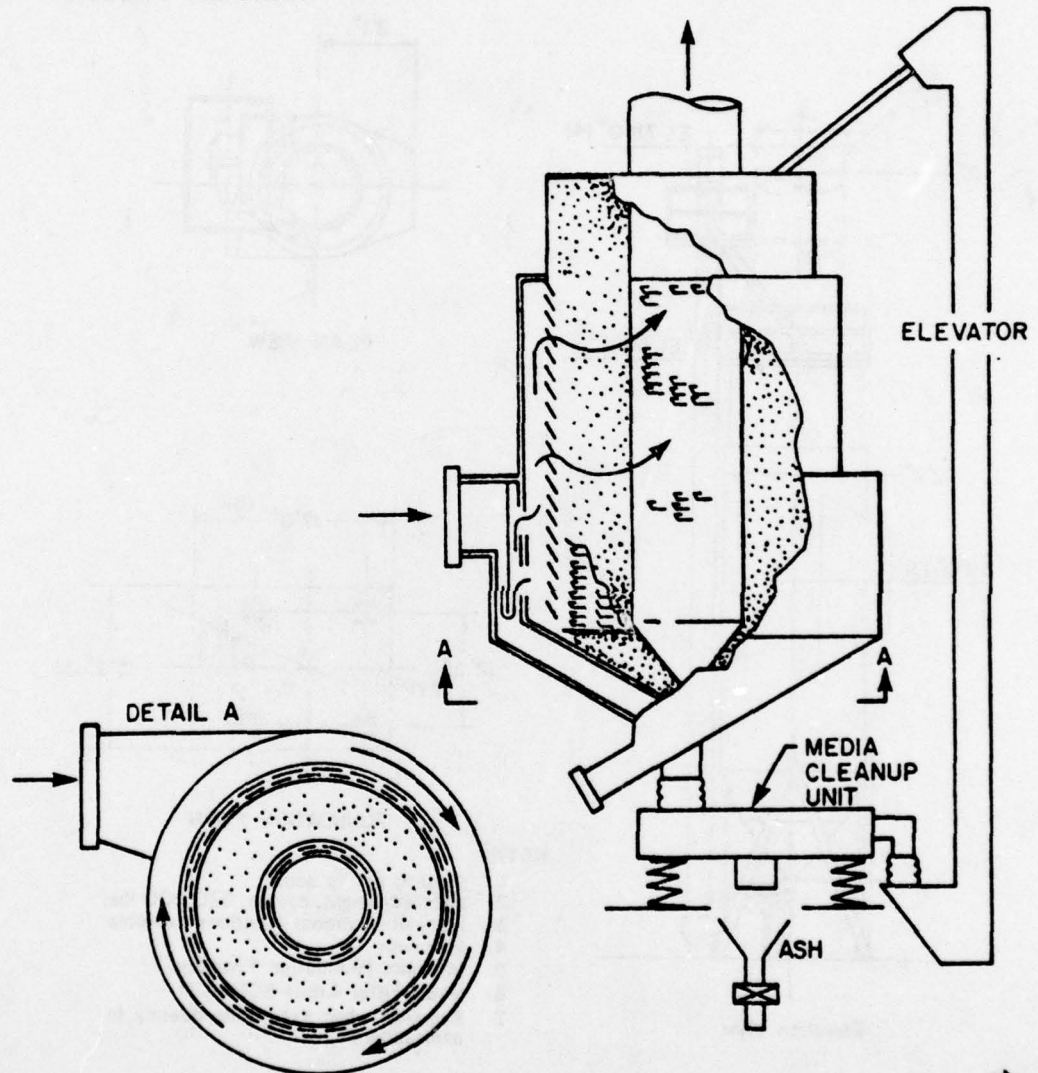

**COMBUSTION POWER COMPANY, INC.**   
1346 WILLOW ROAD, MENLO PARK,  
CALIFORNIA 94025

**Figure E4. Integral cyclone unit.**

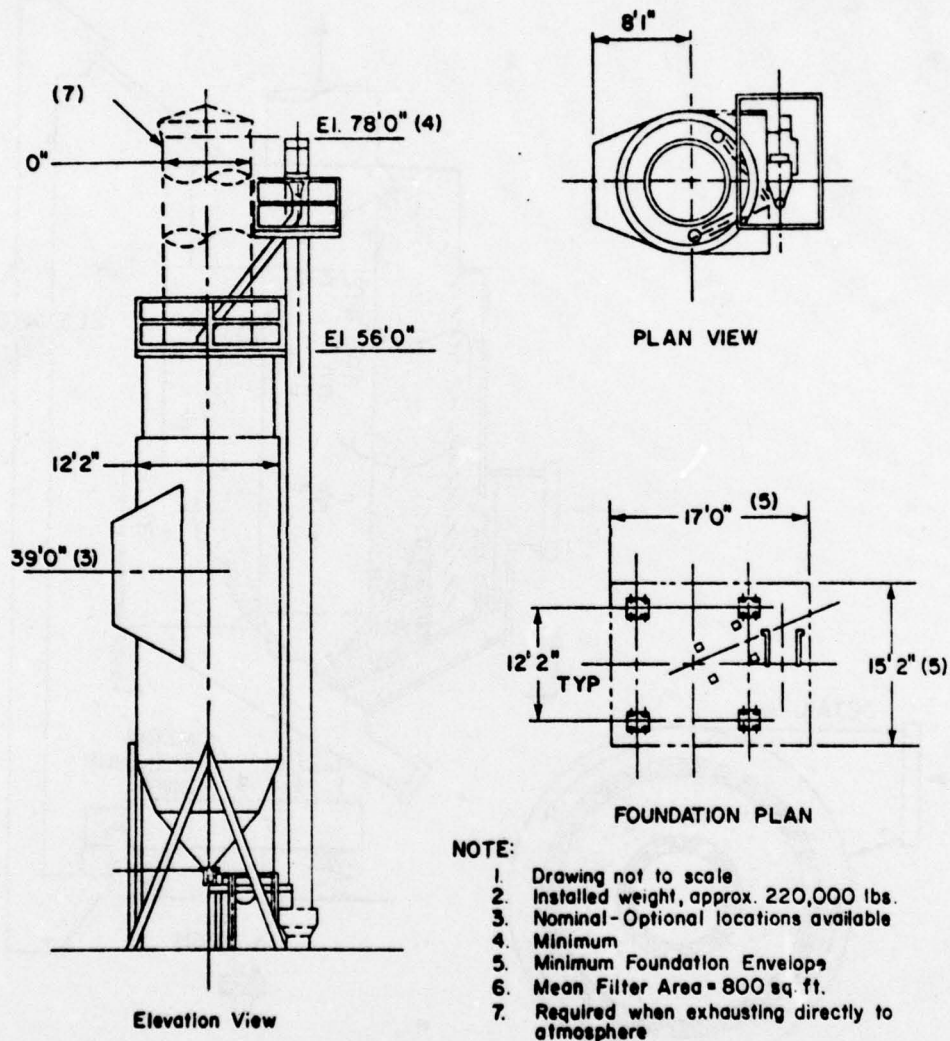

**COMBUSTION POWER COMPANY, INC.**   
 1346 WILLOW ROAD, MENLO PARK,  
 CALIFORNIA 94025

Figure E5. Modular Dry Scrubber (800 sq ft filter area).

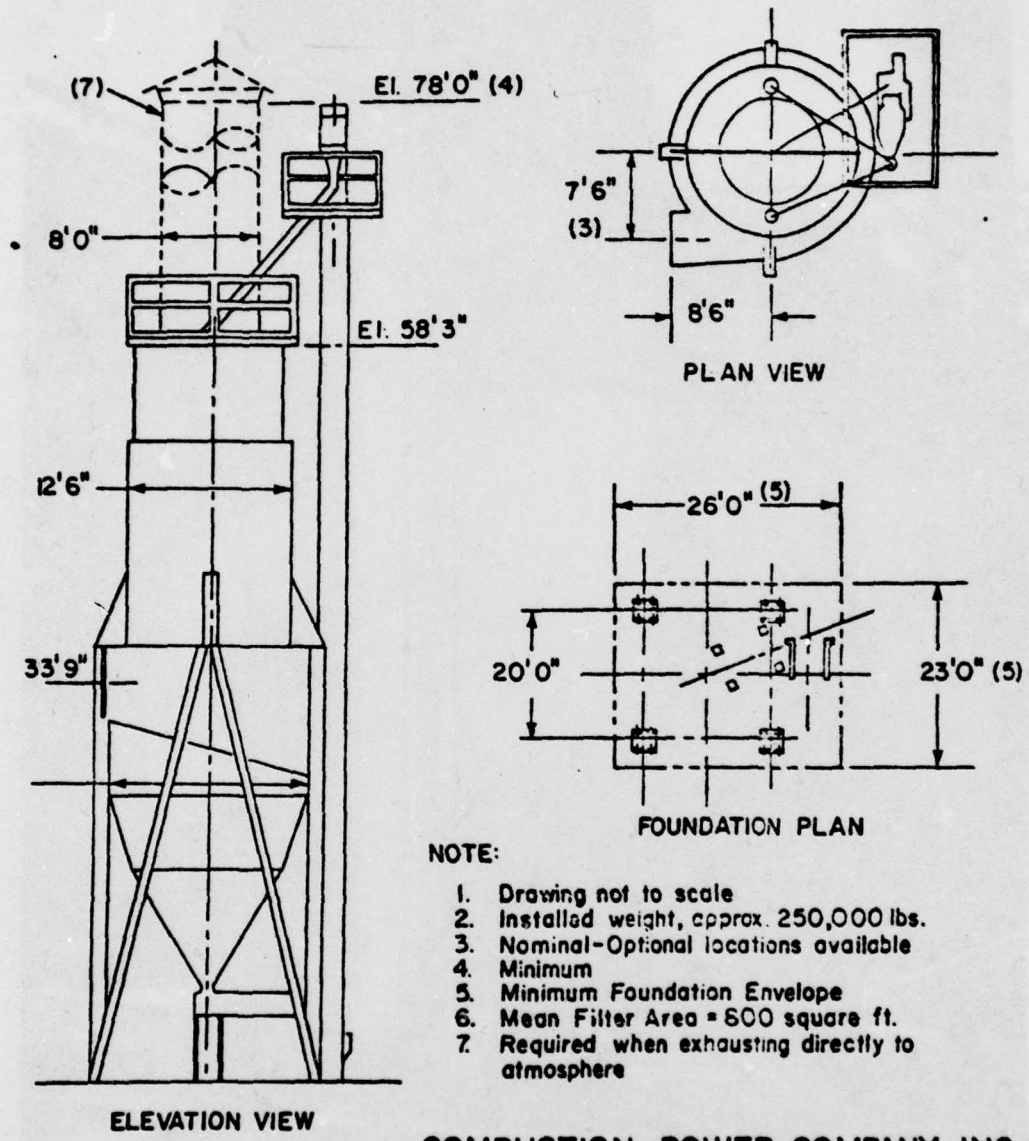

- NOTE:**
1. Drawing not to scale
  2. Installed weight, approx. 250,000 lbs.
  3. Nominal-Optional locations available
  4. Minimum
  5. Minimum Foundation Envelope
  6. Mean Filter Area = 600 square ft.
  7. Required when exhausting directly to atmosphere

**COMBUSTION POWER COMPANY, INC.**   
 1346 WILLOW ROAD, MENLO PARK,  
 CALIFORNIA 94025

**Figure E6. Modular Dry Scrubber with integral cyclone.**

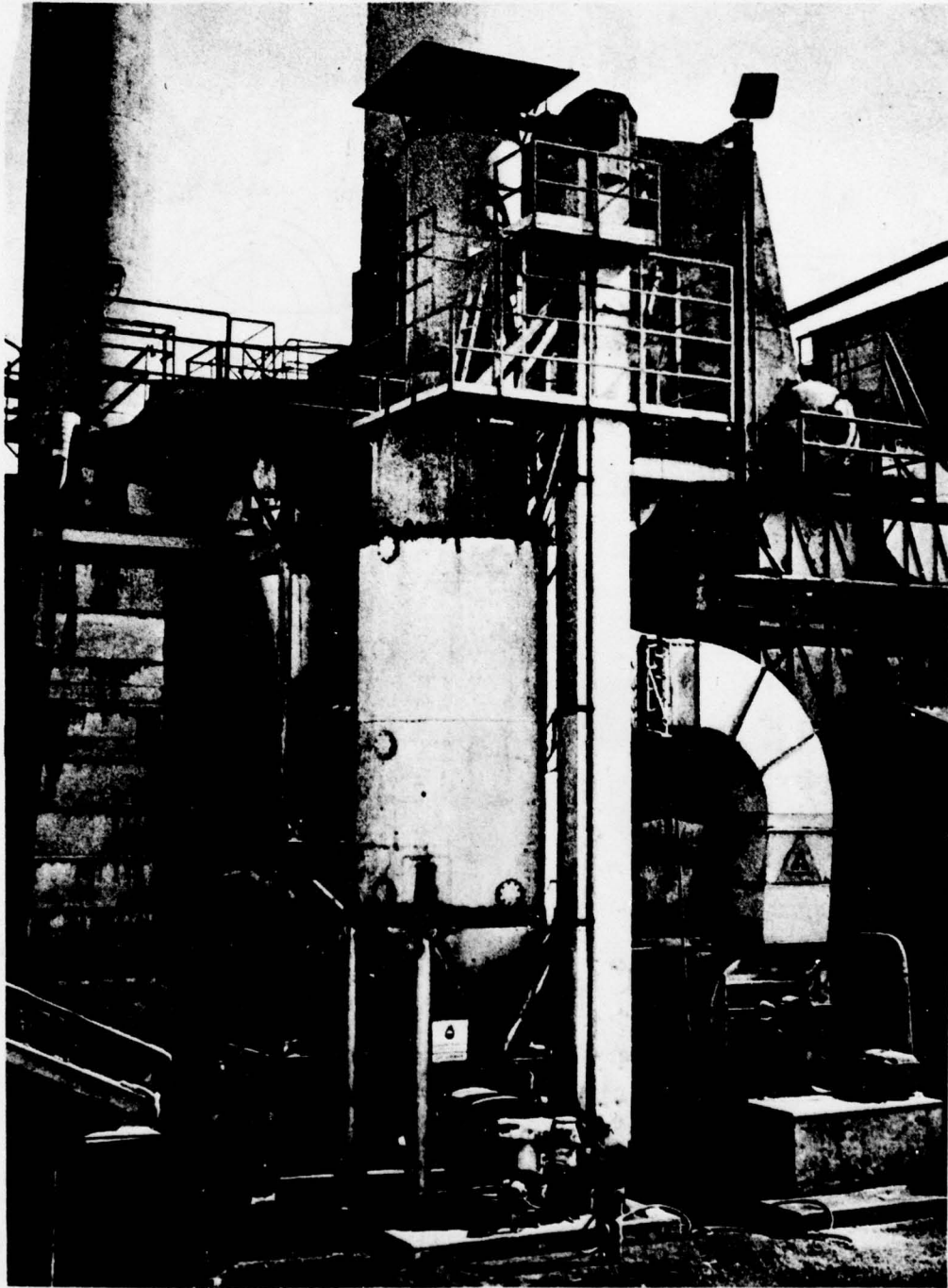
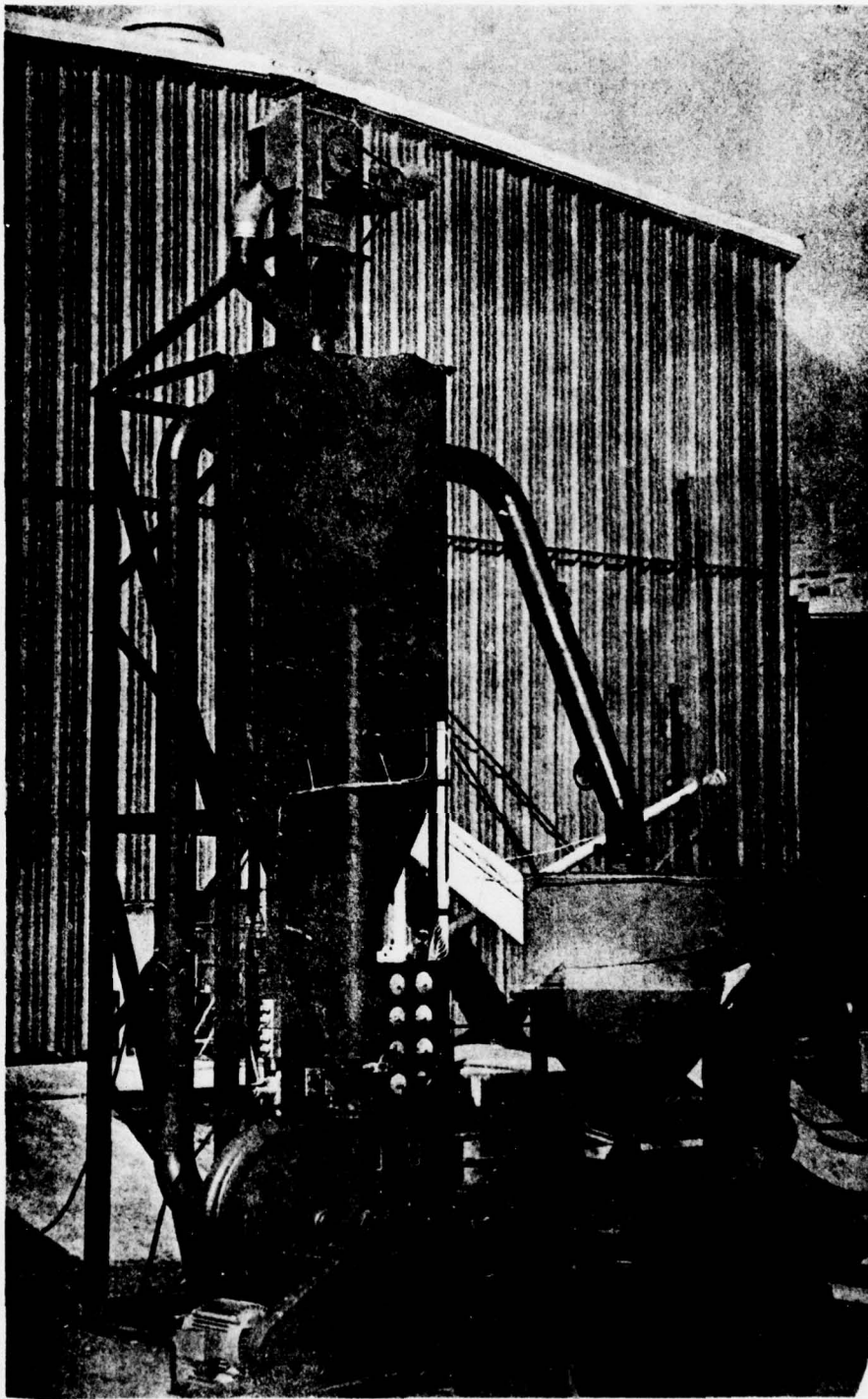

Figure E7. Dry Scrubber unit (365 sq ft), Weyerhaeuser Co., Snoqualmie Falls, WA.



**Figure E8.** Portable, recirculating Dry Scrubber field test unit.

**Table E1**  
**Gas Sample Results, Power Boiler (Waste-Wood and Fuel-Oil Fired)**

Media * Size	Media Gas Velocity (ft/min)	Media Pressure Drop (in water)	Cyclone Pressure Drop (in water)	Total Loading			Collection Efficiency		
				Cyclone in gr/dscf at 12% CO	Media in gr/dscf at 12% CO	Media out gr/dscf at 12% CO	Cyclone %	Media %	Total %
1/4 x 1/8	125	6	1.2	2.768	.875	.075	68.4	91.4	97.3
1/4 x 1/8	170	9.3	2.0	1.486	.609	.080	59	86.9	94.6
6 - 8	150	11.8	1.4	2.542	.80	.07	68.5	91.3	97.3
6 - 8	125	9.7	1.0	4.719	.618	.026	86.9	95.7	99.4

\* 1/4 x 1/8 = 0.250 to 0.125 in.  
6 - 8 = 0.130 to 0.065 in.

## CERL DISTRIBUTION

EPI

Picatinny Arsenal  
 ATTN: SMUPA-VP3  
  
 Director of Facilities Engineering  
 APO New York 09827  
 APO Seattle, WA 98749  
  
 DARCOM SEIT-EUR  
 APO New York 09710  
  
 USA Liaison Detachment  
 ATTN: Library  
 New York, NY 10007  
  
 West Point, NY 10996  
 ATTN: Dept of Mechanics  
 ATTN: Library  
  
 HQDA (SGRD-EDE)  
  
 Chief of Engineers  
 ATTN: Tech Monitor  
 ATTN: DAEN-ASI-L (2)  
 ATTN: DAEN-FEB  
 ATTN: DAEN-FEP  
 ATTN: DAEN-FEU  
 ATTN: DAEN-FEZ-A  
 ATTN: DAEN-MCZ-S  
 ATTN: DAEN-RDL  
 ATTN: DAEN-PMS (7)  
 for forwarding to  
 National Defense Headquarters  
 Director General of Construction  
 Ottawa, Ontario K1A0K2  
 Canada  
  
 Canadian Forces Liaison Officer (4)  
 US Army Mobility Equipment  
 Research and Development Command  
 Ft Belvoir, VA 22060  
  
 Div of Bldg Research  
 National Research Council  
 Montreal Road  
 Ottawa, Ontario, K1A0R6  
  
 Airports and Const. Services Dir.  
 Technical Information Reference  
 Centre  
 KACL, Transport Canada Building  
 Place de Ville  
 Ottawa, Ontario Canada K1A0N8  
  
 USA-CRREL  
  
 USA-WES  
 ATTN: Concrete Laboratory  
 ATTN: Library  
  
 Ft Belvoir, VA 22060  
 ATTN: Kingman Building, Library  
 ATTN: FESA  
  
 Ft Monroe, VA 23651  
 ATTN: ATEN  
 ATTN: ATEN-FE-U  
 ATTN: ATEN-C-C/D, Lyon  
  
 Ft Lee, VA 23801  
 ATTN: DRXMC-D (2)  
  
 Director  
 HQ, US Army Garrison, Honshu  
 ATTN: DFE  
 APO San Francisco 96343  
  
 US Army/FESA  
 Bldg 358  
 Ft Belvoir, VA 22060  
  
 US Army Foreign Science & Tech Center  
 ATTN: Charlottesville, VA 22901  
 ATTN: Far East Office  
  
 6th US Army  
 ATTN: AFKC-LG-E  
  
 US Army Engineer District  
 New York  
 ATTN: Chief, NANEN-E  
 ATTN: Chief, Design Br.  
 Buffalo  
 ATTN: Library  
 Pittsburgh  
 ATTN: Library  
 ATTN: Chief, Engr Div  
 Philadelphia  
 ATTN: Chief, NAPEN-D  
  
 US Army Engineer District  
 Baltimore  
 ATTN: Chief, Engr Div  
 Norfolk  
 ATTN: Library  
 ATTN: Chief, NAOEN-M  
 Huntington  
 ATTN: Library  
 ATTN: Chief, ORHED  
 Wilmington  
 ATTN: Chief, SAMEN-PP  
 ATTN: Chief, SAMEN-D  
 Charleston  
 ATTN: Chief, Engr Div  
 Savannah  
 ATTN: Library  
 ATTN: Chief, SASAS-L  
 Mobile  
 ATTN: Chief, SAMEN-C  
 Nashville  
 ATTN: Library  
 Vicksburg  
 ATTN: Chief, Engr Div  
 Louisville  
 ATTN: Chief, Engr Div  
 Detroit  
 ATTN: Library  
 St. Paul  
 ATTN: Chief, ED  
 Rock Island  
 ATTN: Library  
 ATTN: Chief, Engr Div  
 Chicago  
 ATTN: Chief, NCCPD-ER  
 St. Louis  
 ATTN: Library  
 ATTN: Chief, ED-B  
 ATTN: Chief, ED-D  
 Kansas City  
 ATTN: Library (2)  
 ATTN: Chief, Engr Div  
 Omaha  
 ATTN: Chief, Engr Div  
 New Orleans  
 ATTN: Library  
 ATTN: Chief, LMNED-DG  
 Little Rock  
 ATTN: Chief, Engr Div  
 Tulsa  
 ATTN: Library  
 Fort Worth  
 ATTN: Library  
 ATTN: Chief, SWFED-D  
 ATTN: Chief, SWFED-MA/MR  
 Albuquerque  
 ATTN: Library  
 Los Angeles  
 ATTN: Library  
 San Francisco  
 ATTN: Chief, Engr Div  
 Sacramento  
 ATTN: Library, Room 8307  
 ATTN: Chief, SPKED-D  
 Far East  
 ATTN: Chief, Engr Div  
 Japan  
 ATTN: Library  
 Portland  
 ATTN: Library  
 Seattle  
 ATTN: Chief, NPSEN-PL-WC  
 ATTN: Chief, NPSEN-PL-ER  
 Walla Walla  
 ATTN: Library  
 ATTN: Chief, Engr Div  
 Alaska  
 ATTN: Library  
 ATTN: Chief, NPADE-R  
  
 US Army Engineer Division  
 Europe  
 ATTN: Technical Library  
 New England  
 ATTN: Library  
 ATTN: Chief, NEDED-T  
 North Atlantic  
 ATTN: Library  
 ATTN: Chief, NADEN-T  
 Middle East (Rear)  
 ATTN: MEDED-T  
 South Atlantic  
 ATTN: Chief, SAEN-TE  
 ATTN: Library  
 Huntsville  
 ATTN: Library (2)  
 ATTN: Chief, HNDED-SR  
 ATTN: Chief, HNDED-CS  
 ATTN: Chief, HNDED-ME  
 Lower Mississippi Valley  
 ATTN: Library  
  
 US Army Engineer Division  
 Ohio River  
 ATTN: Laboratory  
 ATTN: Library  
 ATTN: Chief, Engr Div  
 North Central  
 ATTN: Library  
 ATTN: Chief, Engr Div  
 Missouri River  
 ATTN: Library (2)  
 ATTN: Chief, Engr Div  
 ATTN: Laboratory  
 Southwestern  
 ATTN: Library  
 ATTN: Chief, SWDED-TM  
 South Pacific  
 ATTN: Chief, SPDED-TG  
 Pacific Ocean  
 ATTN: Chief, PODED-D  
 ATTN: Chief, PODED-P  
 ATTN: Chief, PODED-MP  
 ATTN: Chief, Engr Div  
 North Pacific  
 ATTN: Chief, Engr Div  
  
 Facilities Engineer  
 Carlisle Barracks, PA 17013  
 Ft Hood, TX 76544  
 FORSCOM  
 Ft Devens, MA 01433  
 Ft George G. Meade, MD 20755  
 Ft McPherson, GA 30330  
 Ft Sam Houston, TX 78234  
 Ft Carson, CO 80913  
 Ft Lewis, WA 98433  
 USAECOM  
 Ft Monmouth, NJ 07703  
 TRADOC  
 Ft Dix, NJ 08640  
 Ft Belvoir, VA 22060  
 Ft Lee, VA 23801  
 Ft Gordon, GA 30905  
 Ft McClellan, AL 36201  
 Ft Knox, KY 40121  
 Ft Benjamin Harrison, IN 46216  
 Ft Leonard Wood, MO 65473  
 Ft Sill, OK 73503  
 Ft Bliss, TX 79916  
 USATCFE  
 Ft Eustis, VA 23604  
 DSCPER  
 West Point, NY 10996  
 USAIC (3)  
 Ft Benning, GA 31905  
 USAAVNC  
 Ft Rucker, AL 36361  
 CAC&FL (2)  
 Ft Leavenworth, KS 66027  
 AMC  
 Dugway, UT 84022  
 USACC  
 Ft Huachuca, AZ 85613  
 HQ, 1st Inf Div & Ft Riley, KS 66442  
 HQ, 7th Inf Div & Ft Ord, CA 93941  
  
 AF/PREEU  
 Bolling AFB, DC 20332  
  
 AF Civil Engr Center/XRL  
 Tyndall AFB, FL 32401  
  
 Little Rock AFB  
 ATTN: 314/DEE (Mr. Gillham)  
  
 Kirtland AFB, NM 87117  
 ATTN: Technical Library (SUL)  
  
 Naval Facilities Engr Command  
 ATTN: Code 04  
 Alexandria, VA 22332  
  
 Port Hueneme, CA 93043  
 ATTN: Library Code (L0BA)  
 ATTN: Moreell Library  
  
 Washington, DC  
 ATTN: Bldg Research Advisory Board  
 ATTN: Transportation Research Board  
 ATTN: Library of Congress (2)  
 ATTN: Federal Aviation Administration  
 ATTN: Dept of Transportation Library  
  
 Defense Documentation Center (12)  
  
 Engineerin Societies Library  
 New York, NY 10017

Commander  
HQ, XVIII Airborne Corps and  
Fort Bragg  
ATTN: AFZA-FE-EE  
Fort Bragg, NC 28307

HQ, 7th Army Training Command  
ATTN: AETTG-DEH (5)  
APO New York 09114

Commander  
HQ USAEREUR and 7th Army  
ODCS/Engineer  
ATTN: AEAEN-EH (4)  
APO New York 09403

Commander  
7th Army Combined Arms Training  
Center  
ATTN: AETTM-HRD-EHD  
APO New York 09407

US Army Engr Div, Europe  
ATTN: Technical Library (3)  
APO New York 09757

Commander  
V Corps  
ATTN: AETVDEH  
APO New York 09079

Commander  
VII Corps  
ATTN: AETSDEH  
APO New York 09154

Commander  
21st Support Command  
ATTN: AEREH  
APO New York 09325

Commander  
US Army Berlin  
ATTN: AEBA-FN  
APO New York 09742

Commander  
US Army Southern European Task Force  
ATTN: AESE-ENG  
APO New York 09168

Commander  
US Army Installation Support  
Activity, Europe  
ATTN: AEUES-RP  
APO New York 09403

Long Beach Naval Shipyard  
LT Neil B. Hall, USNR/Code 403  
Long Beach, CA 90822

Collishaw, Anslie N

Technical evaluation study : energy recovery from solid waste at Ft Dix, NJ and nearby civilian communities / by A. N. Collishaw, S. A. Hathaway. -- Champaign, IL : Construction Engineering Research Laboratory ; Springfield, VA : available from NTIS, 1978.

52 p. ; 27 cm. (Technical report ; E-136)

1. Refuse as fuel. 2. Ft Dix, NJ. I. Hathaway, Steve A. 3. McGuire AFB, NJ. I. Title. II. Title: Energy recovery from solid waste at Ft Dix, NJ, and nearby civilian communities. III. Series: U.S. Construction Engineering Research Laboratory. Technical report ; E-136.