

AD-A062 740

ROCKWELL INTERNATIONAL ANAHEIM CA AUTONETICS MARINE --ETC F/G 17/2
ADVANCED SUBMARINE CONTROL PROGRAM.(U)
OCT 78

N00024-78-C-5308

UNCLASSIFIED

C78-1091/301

NL

1 OF 4

AD
A0 62740



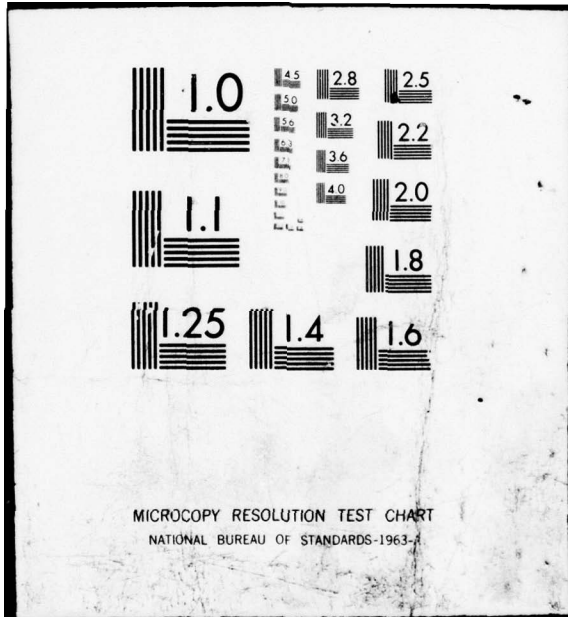

AD A062740

DDC FILE COPY

LEVEL

12

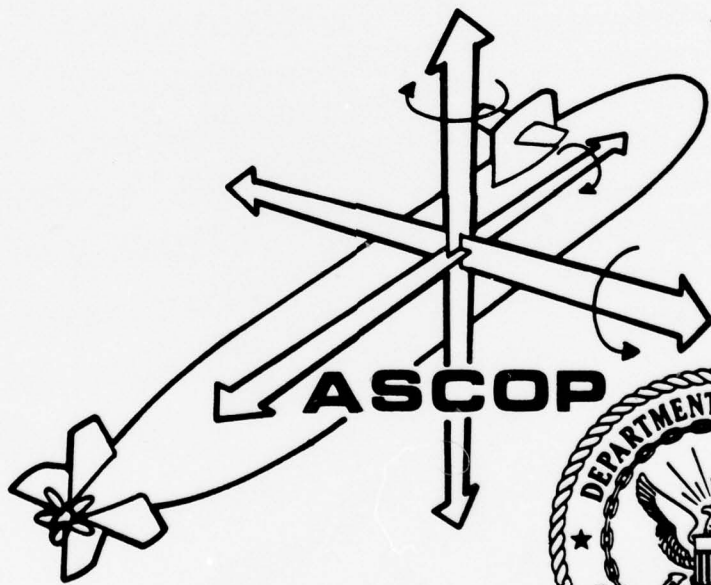

DDC
 RECEIVED
 JAN 2 1979
 F



ADVANCED SUBMARINE CONTROL PROGRAM

This document has been approved for public release and wider distribution is unlimited.

78 11 24 079

141
C78-1091/301

6
ADVANCED SUBMARINE CONTROL PROGRAM.

9 FINAL REPORT. 1 part - 30 Sep 78.

OCTOBER 31, 1978

11 31 Oct 78

12 326p.

DDC
RECEIVED
JAN 2 1979
F

Prepared for:

NAVAL SEA SYSTEMS COMMAND
CODE 03222
ADVANCED SUBMARINE CONTROL PROGRAM

15
CONTRACT N00024-78-C-5308

Prepared by:

AUTONETICS MARINE SYSTEMS DIVISION
ROCKWELL INTERNATIONAL CORPORATION

This document has been approved
for public release and sale; its
distribution is unlimited.

409098

15

FOREWORD

This report documents all work performed by Autonetics Marine Systems Division (AMSD), Rockwell International Corporation under NAVSEA Contract N00024-78-C-5308. The period of performance was from 1 June 1978 through 30 September 1978.

ACCESSION for

NTIS	White Section <input checked="" type="checkbox"/>
DDC	Buff Section <input type="checkbox"/>
UNANNOUNCED	<input type="checkbox"/>
JUSTIFICATION	<i>for file</i>
BY	DISTRIBUTION/AVAILABILITY CODES
D/R:	SPECIAL
A	

Table of Contents

	Page
Foreword.....	ii
1.0 Introduction.....	1
2.0 System Data Transfer.....	3
2.1 Shipboard System Overview.....	4
2.2 Laboratory Demonstration System Overview.....	6
2.3 Data Terminal.....	10
2.3.1 Data Terminal Control.....	12
2.3.2 Serial I/O Data Transfer.....	12
2.3.3 First-In, First-Out Memory.....	18
2.3.4 Sequence Controller.....	18
2.3.5 Microcomputer.....	19
2.3.6 Digital Multiplexer.....	21
2.3.7 Analog-To-Digital Converter.....	21
2.3.8 Analog Data Select.....	21
2.3.9 Sensor Conditioning Units.....	21
2.3.10 Actuator Signal Converters.....	22
2.4 Command/Display Interface Unit.....	22
2.4.1 C/D IU Control.....	22
2.4.2 Serial I/O Data Transfer.....	24
2.4.3 Parallel I/O Data Transfer.....	25
2.5 Summary.....	30
3.0 Multifomat Display.....	31
3.1 Mechanization Tradeoffs.....	32
3.1.1 Cathode-Ray Tube Graphics.....	33
3.1.1.1 Raster Graphics.....	33
3.1.1.2 Stroke Graphics.....	35
3.1.2 Flat Panel Displays.....	39
3.1.3 Touch Overlay Control.....	41
3.1.4 Electroluminescence.....	43
3.2 Candidate Technologies.....	43
3.2.1 Technology Overview.....	43
3.2.1.1 Cathode-Ray Tube Technology.....	44
3.2.1.2 Plasma Display Technology.....	45

Contents (continued)

	Page
3.2.1.3 Electroluminescence Display Technology.....	45
3.2.2 Multifomat Display Characteristics.....	46
3.2.2.1 Active Area.....	46
3.2.2.2 Density of Information.....	46
3.2.2.3 Update Rate/Amount of Changing Information.....	47
3.2.2.4 Total Number of Formats.....	47
3.2.2.5 Type of Font.....	47
3.2.2.6 Type of Graphics.....	47
3.3 Mechanization Approaches.....	48
3.3.1 Resolutions.....	48
3.3.2 Refresh Rate.....	49
3.3.3 Brightness.....	49
3.3.4 Contrast.....	49
3.3.5 Brightness Variations.....	49
3.3.6 Jitter and Drift.....	49
3.3.7 Deflection.....	50
3.4 Interface.....	50
3.5 Modularization.....	50
3.5.1 Cathode-Ray Tube.....	51
3.5.2 Flat Panel Displays.....	51
4.0 Control/Display Integration.....	53
4.1 Functional Flow Diagrams.....	53
4.2 Functional Allocation.....	54
4.3 Information/Action Analysis.....	55
4.4 Summary and Recommendations.....	56
Appendix A Functional Flow Diagrams for the Top Level Function "Perform Open Ocean Transit".....	A-1
Appendix B Four-Man Crew Functional Allocation Table.....	B-1
Appendix C Three-Man Crew Functional Allocation Table.....	C-1
Appendix D Two-Man Crew Functional Allocation Table.....	D-1
Appendix E Information Requirements Analysis.....	E-1
Appendix F Action Requirements Analysis.....	F-1

Illustrations

Figure No.	Title	Page
1	System Data Transfer Block Diagram.....	5
2	Integration Laboratory System Data Transfer Block Diagram.....	7
3	Abbreviated Data Terminal Block Diagram.....	9
4	Data Terminal (Half) Block Diagram.....	11
5	Serial I/O Data Transfer.....	13
6	Serial Message Formats.....	14
7	Command/Display Interface Unit (Half) Block Diagram.....	23
8	Parallel Message Formats.....	26
9	Parallel Message Relative Timing.....	29
10	Raster Graphics Diagram.....	34
11	Raster Graphics Generator Diagram.....	36
12	Stroke Graphics Generator Diagram.....	37
13	Flat Panel Display Diagram.....	40
14	Touch Panel Block Diagram.....	42

Tables

Table No.	Title	Page
I	Serial Message Formats.....	15
II	Microcomputer Interface Functions.....	20
III	Top Level Display Requirements.....	32

1.0 INTRODUCTION

This report documents work performed from 1 June 1978 through 30 September 1978 by Autonetics Marine Systems Division (AMSD) under NAVSEA Contract Number N00024-78-C-5308 and referred to herein as Task VI, Part II. All effort was performed for, and under the technical direction of, the Advanced Submarine Control Program (ASCOP) NAVSEA 03222. Under the terms of the contract and at the direction of the ASCOP Program Manager, four sub-tasks were performed. These sub-tasks were a continuation of effort initiated under Contract No. N00024-77-C-4156, referred to herein as Task VI, Part I.

During Task VI, Part I, a hybrid signal list was developed. Sub-task 1 of Task VI, Part II was a continuation of this effort to include signal characteristics, voltage and operating frequency, and an assessment of wire requirements for present mechanizations. Using sub-task 1 as a working basis, sub-task 2 resulted in a signal conditioning concept and a feasibility assessment of existing SDMS* signal conversion techniques. Results of these two efforts are reported in Section 2. During sub-task 3, mechanization tradeoffs were developed and evaluated for display technologies applicable to a multiformat display. These data were the basis for the recommendations presented in Section 4.4 and are reported in Section 3. Sub-task 4 resulted in development of functional flow diagrams for standard and emergency conditions and function allocations and information/action requirements, including the multiformat display consideration for 4, 3, and 2 man crews. An overview of this task is reported in Section 4. The functional flow diagrams are included in Appendix A with the function allocations for a four-man, a three-man, and a two-man crew reported in Appendices B, C, and D respectively. Information requirements are listed in Appendix E and action requirements are reported in Appendix F.

* (Shipboard Data Multiplex System)

Each of the following Sections is organized so as to present to the reader a description of the technical effort performed and conclusions derived.

2.0 SYSTEM DATA TRANSFER

The primary objective of this task was to examine the data transfer requirements necessary to support an ACS* development program. Recognizing that the thrust of ASCOP is the development of an ACS vis-a-vis a shipboard data transfer system, only that effort necessary to assure that the proper signals and commands could be made available to the control station in the correct format and with the desired timing was expended. Coupled with this was the further consideration that ASCOP is pursuing a long term ship control station objective which must start with concept validation. Hence, the activity reported here was the concept definition necessary to support a laboratory demonstration model of an Advanced Control Station and not the detailed design of a shipboard data transfer system.

A secondary objective was to examine existing SDMS designs to determine the extent that they could be used in the laboratory demonstration model. In doing this, it was determined that SDMS has progressed to the point of full MIL SPEC prototype hardware design for shipboard utilization and as such would not be cost effective for a laboratory demonstration model. However, the engineering design imbedded in SDMS is included where appropriate.

Before proceeding to a description of the laboratory data transfer system, one last point should be made. The ultimate objective of ASCOP is to introduce improved ship control equipment to the fleet. As such, any R&D program that does not track with the reality of ship

* Advanced Control Station

design, construction and operation will never lead to operational hardware. Therefore, Section 2.1 presents a top level description of a shipboard data transfer system interfacing with an ACS and it is the task before ASCOP to validate this interface design. This leads to the need for a laboratory model that is both cost effective and representative of the shipboard system. Section 2.2 describes such a laboratory model with direct traceability to the shipboard system. Both systems consist fundamentally of DTs* and C/D IUs** as described in Sections 2.3 and 2.4. In both of these cases, cost-effective compromise have been made for the laboratory model as described in Section 2.2

2.1 SHIPBOARD SYSTEM OVERVIEW

Figure 1 is a simplified ship system data transfer block diagram. The overall concept considers the fact that various sensors and actuators are widely distributed over the ship, but are all being monitored or controlled from a central position, i.e., the Ship Control Station. This leads to the concept of remote DTs strategically located about the ship. These DTs sample and consolidate data from the various sensors, then digitize and transmit these data over a common link to the C/D IU. Data that are required by any user other than the source are stored in the C/D IU.

All users, which include data terminals, computers, and command/display panels, contain their own control logic. Each need only communicate with the C/D IU to receive data from any source or to route data to any sink. Because this communication is accomplished via a data bus, users can be readily added, removed, or relocated, hence the central data buffer store provides design flexibility.

* Data Terminals

** Command/Display Interface Units

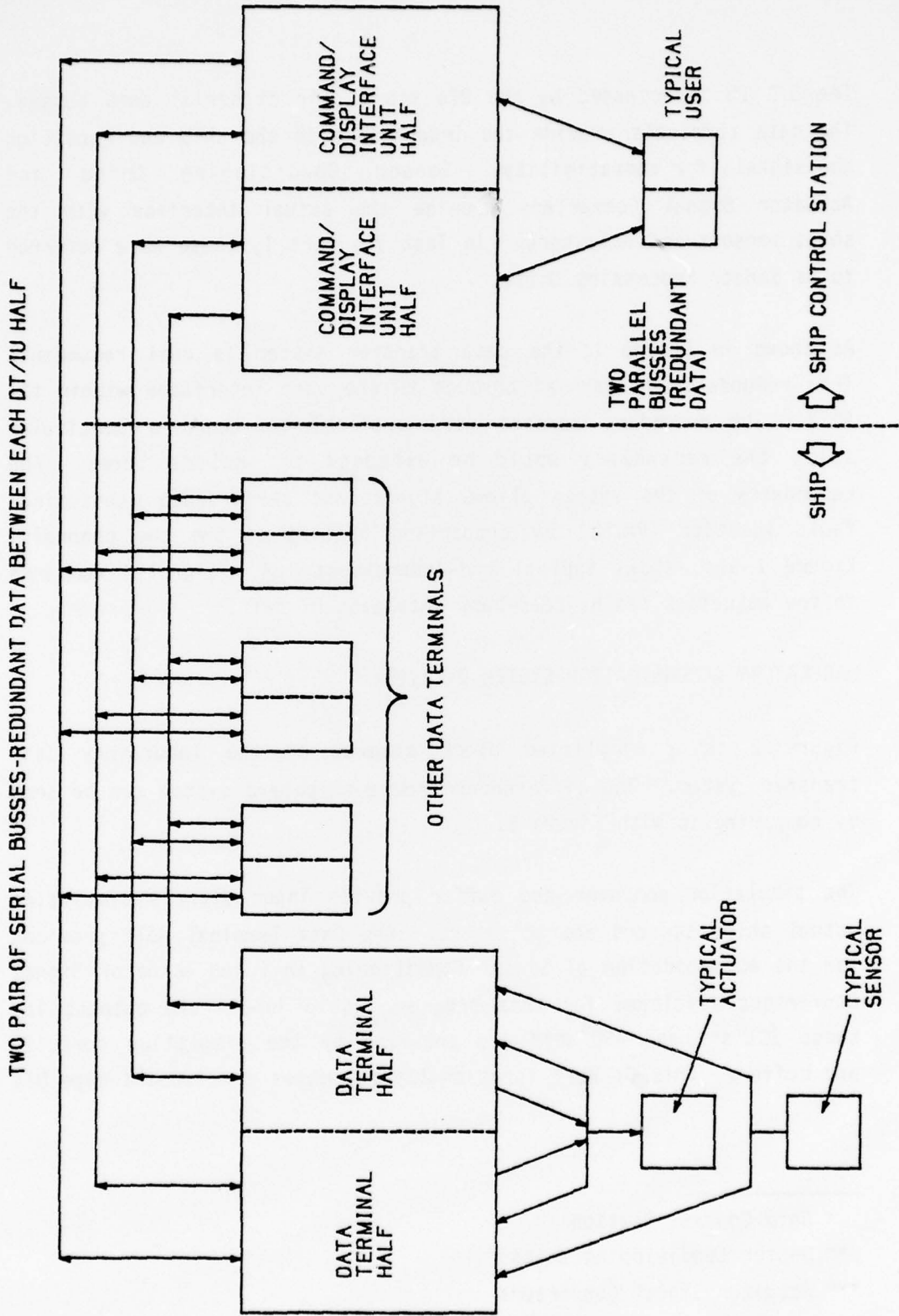

TWO PAIR OF SERIAL BUSES-REDUNDANT DATA BETWEEN EACH DT/1U HALF

COMMAND/
DISPLAY
INTERFACE
UNIT
HALF

COMMAND/
DISPLAY
INTERFACE
UNIT
HALF

TWO
PARALLEL
BUSES
(REDUNDANT
DATA)

SHIP CONTROL STATION

SHIP

OTHER DATA TERMINALS

DATA
TERMINAL
HALF

DATA
TERMINAL
HALF

TYPICAL
ACTUATOR

TYPICAL
SENSOR

SYSTEM DATA TRANSFER BLOCK DIAGRAM

FIGURE 1

The C/D IU is accessed by the DTs via a pair of serial data busses. The data terminals provide the interface with the ship and condition the signals for compatibility. Sensor Conditioning Units and Actuator Signal Converters provide the actual interface with the ships sensors and actuators. In Task VI, Part I, these were referred to as Sensor Processing Units.

As shown in Figure 1, the data transfer system is dual redundant. This redundancy is carried through to the user interfaces within the SCS*. If redundant sensors were available on-board a particular ship, the redundancy would be extended to include them. The redundancy of the system allows significant performance monitoring/fault location (PM/FL) by comparison testing of the two channels. Figure 1 also shows typical end-around-test (EAT) signals. Commands to the actuators can be read-back into each DT half.

2.2 LABORATORY DEMONSTRATION SYSTEM OVERVIEW

Figure 2 is a simplified block diagram of the laboratory data transfer system. The differences from a shipboard system can be seen by comparing it with Figure 1.

The simulation computer and buffer provide input signals simulating actual ships sensors and actuators. One Data Terminal Half provides for the accommodation of Sensor Conditioning Unit and Actuator Signal Converters developed for this program. Ship inputs and outputs for these SCU's** and ASC's*** are provided by the simulation computer and buffer. This DT Half functionally resembles a shipboard type DT.

* Ship Control Station

** Sensor Conditioning Units

*** Actuator Signal Converters

TWO PAIR OF SERIAL BUSES-REDUNDANT DATA BETWEEN EACH DT/1U HALF

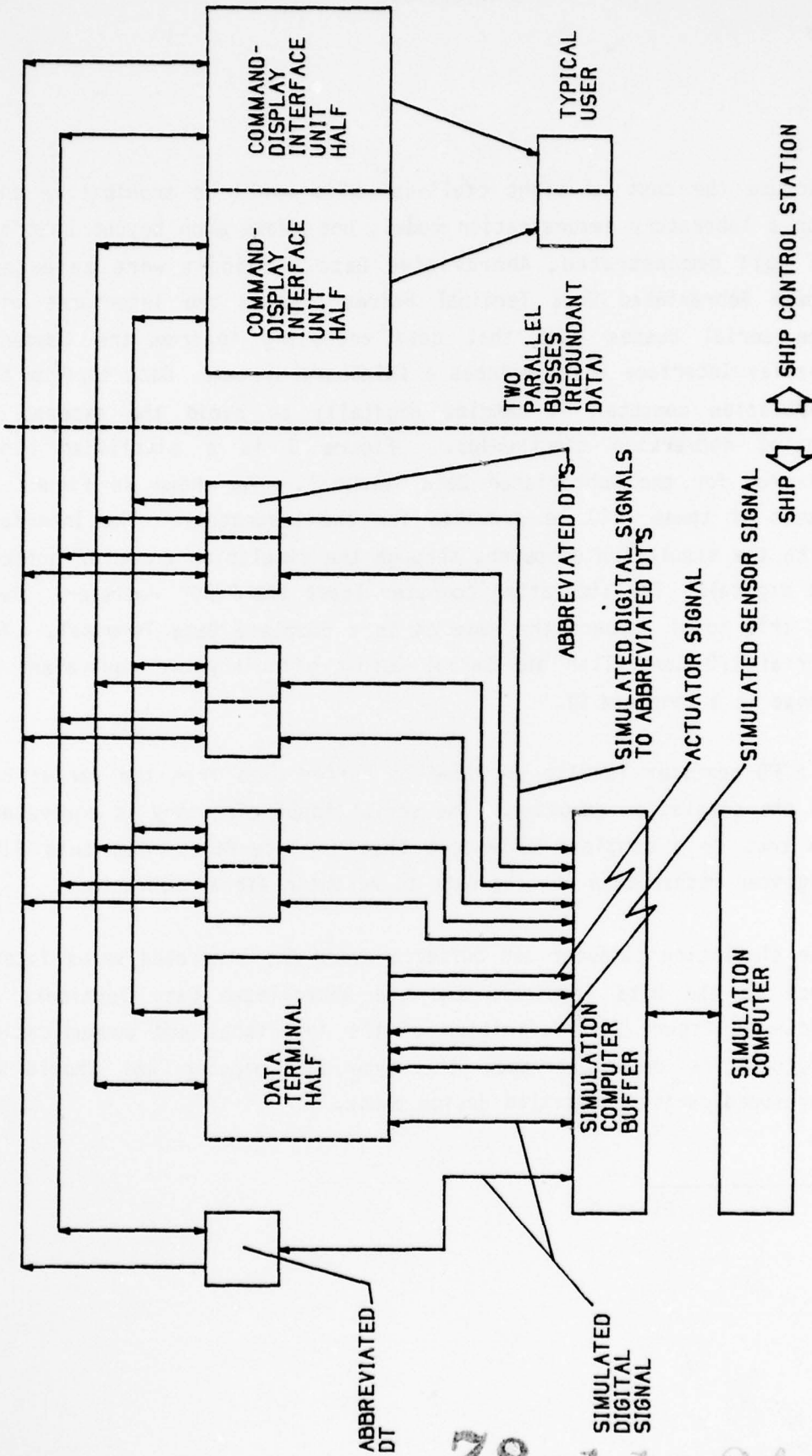

INTEGRATION LABORATORY SYSTEM DATA TRANSFER BLOCK DIAGRAM

FIGURE 2

78 11 24 079

Because the cost of eight "full-up" DT's would be prohibitive and, for a laboratory demonstration model, not prove much beyond what one DT Half demonstrated, Abbreviated Data Terminals were selected. These Abbreviated Data Terminal Halves provide the interfaces with the serial busses such that data accessing to/from the Command/Display Interface Units matches a shipboard system. Data to/from the simulation computer is handled digitally to avoid the expense of analog conversion electronics. Figure 3 is a simplified block diagram for the Abbreviated Data Terminal. As shown in Figure 2, seven of these will be provided for the laboratory. The interface with the simulation computer, through the simulation computer buffer, is digital. The simulation computer loads the FIFO* register. Data at this point appears the same as in a complete Data Terminal. The Serial I/O Controller and Serial Output circuitry are equivalent to those in a complete DT.

A FIFO register is also provided to buffer data from the serial bus to the simulation computer. The serial input circuitry is equivalent to that in a complete DT except that it interfaces with this FIFO register rather than routing data to actuator signal converters.

The simulation computer and buffer provide the simulated ships interface to the Data Terminals and the abbreviated Data Terminals as shown in Figure 2. Definition of the interfaces and communication protocol is dependent upon the type of computer and should be developed during a detailed design phase.

* First-In, First-Out

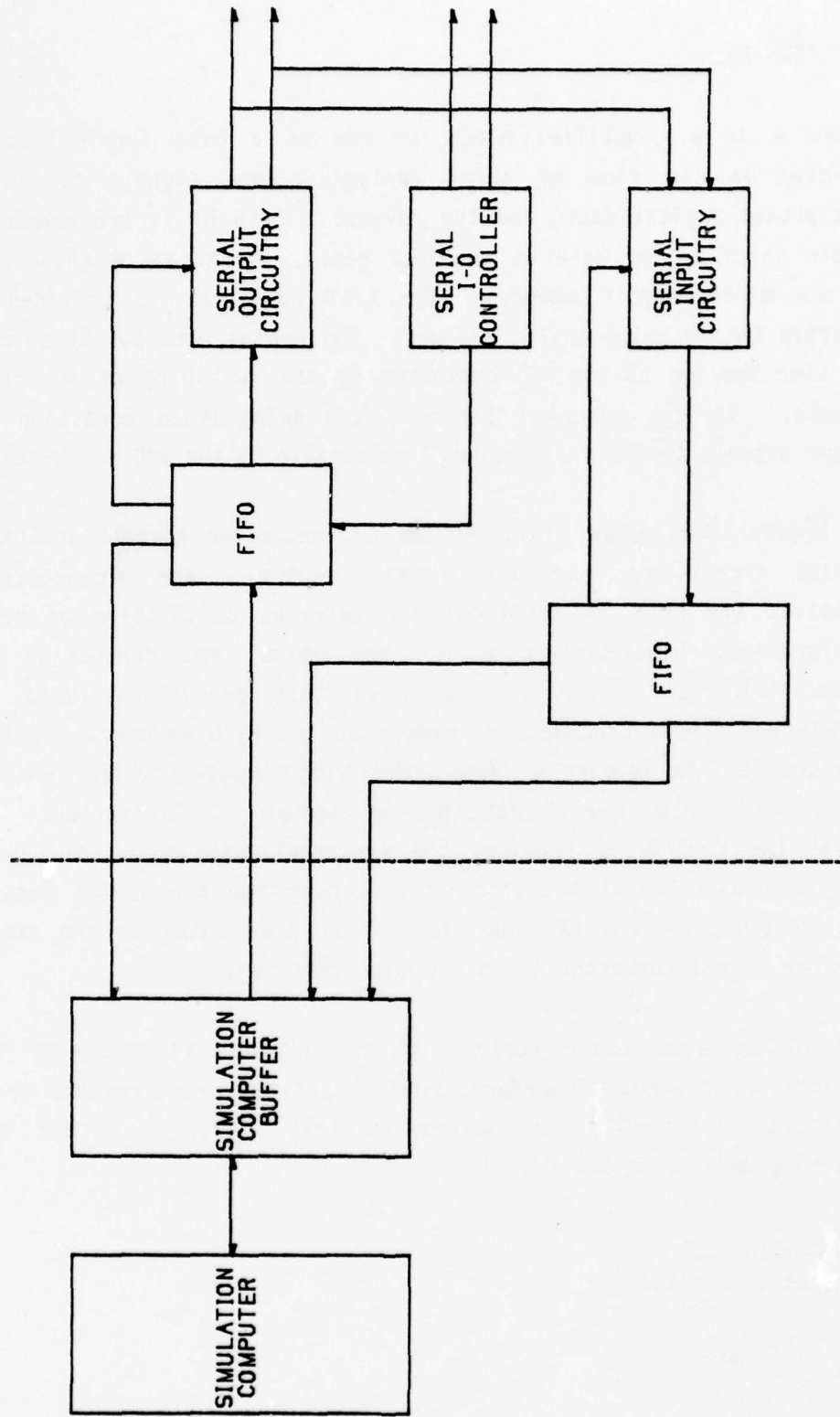

ABBREVIATED DATA TERMINAL
BLOCK DIAGRAM
FIGURE 3

2.3 DATA TERMINAL

Figure 4 is a simplified block diagram of a Data Terminal Half. Depicted is the flow of ships analog/discrete signals to serial multiplexed digital data, and the reverse. Each DT is programmed to sample ships sensor data at required rates, and to store these data in the microcomputer memory. The A/D* converter is provided to digitize the incoming analog signals. The Analog Data Select enables the time sharing of the A/D converter by the switching of its input signals. Various types of Sensor Conditioning Units condition the sensor signals to the voltage range measurable by the A/D converter.

The Digital Multiplexer switches the A/D converter signals and other digital signals to the microcomputer memory. The microcomputer processes the data as required; for example, calculation of rate/acceleration, formatting data for the users, and monitoring for sensor failures. Upon completion of this processing, data are transferred from microcomputer memory to the FIFO memory. The FIFO provides for the loading of data under microcomputer control and the asynchronous unloading of data by the Serial I/O Controller. The Serial I/O Controller provides the synchronization with the C/D IU for the bidirectional transfer of data over the two serial busses. Data received by the DT from the C/D IU are routed to the proper Actuator Signal Converter or to the microcomputer.

Each DT operates under control of an integral microcomputer and Sequence Controller. Therefore, revision of data requirements for a particular DT results in changes to that DT only, rather than requiring changes to the C/D IU.

* Analog-to-Digital

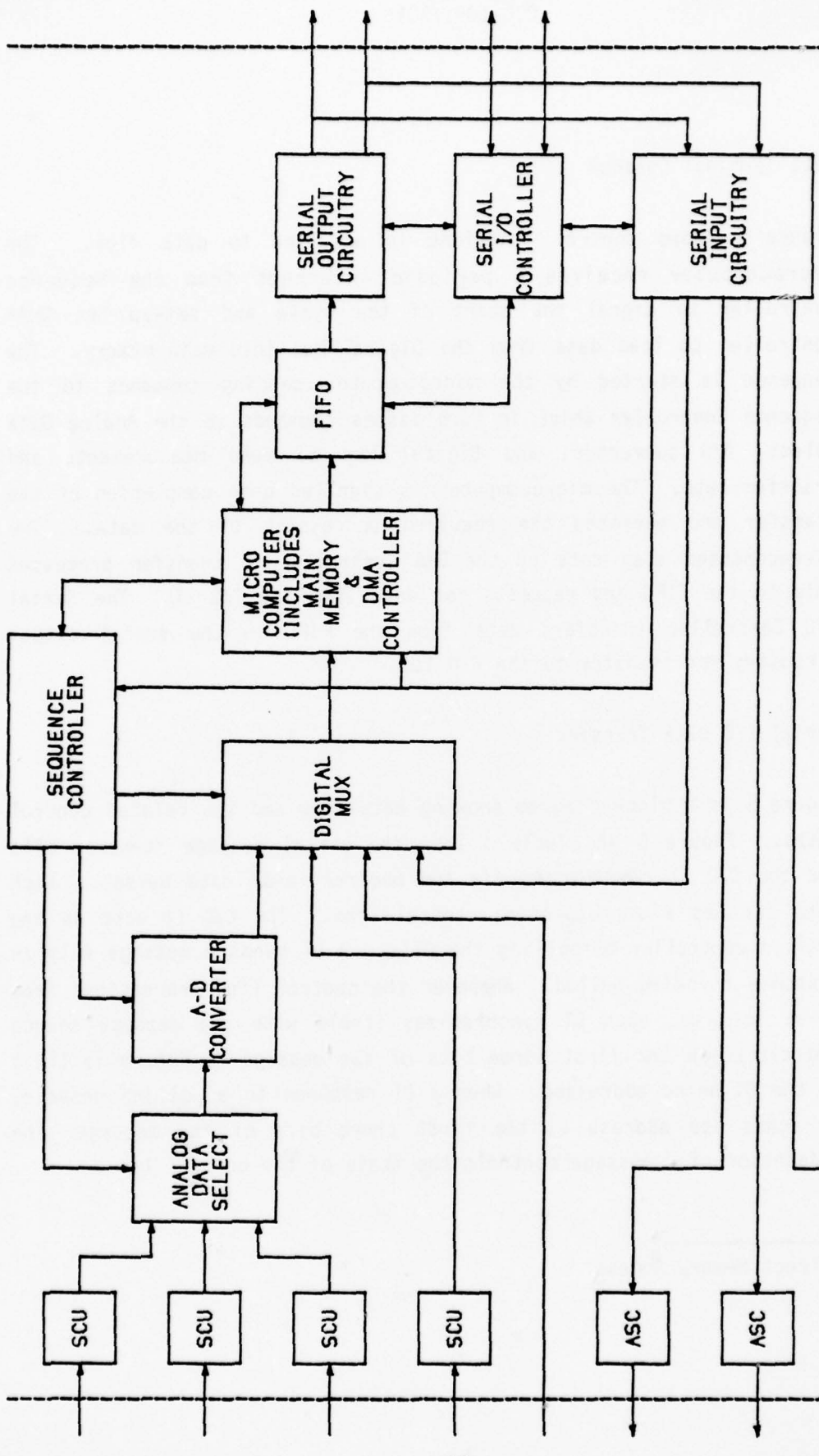

DATA TERMINAL (HALF)
BLOCK DIAGRAM

FIGURE 4

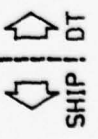
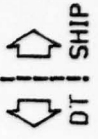

2.3.1 Data Terminal Control

Figure 4 shows control functions in addition to data flow. The microcomputer receives a periodic interrupt from the Sequence Controller to signal the start of the cycle and set-up the DMA* Controller to load data from the Digital Mux into main memory. The sequence is started by the microcomputer sending commands to the Sequence Controller which in turn issues commands to the Analog Data Select, A/D converter, and Digital Mux to make measurements and transfer data. The microcomputer is signaled upon completion of the transfer and performs the required processing of the data. The microcomputer also sets up the DMA Controller to transfer processed data to the FIFO and requests for data from the C/D IU. The Serial I/O Controller transfers data from the FIFO to the serial output circuitry for transfer to the C/D IU.

2.3.2 Serial I/O Data Transfer

Figure 5 is a block diagram showing data flow and the related control paths. Figure 6 and Table I show the serial message formats. DT's and the C/D IU communicate via two bidirectional data busses. Each data bus has a corresponding control line. The C/D IU acts as the traffic controller by polling the DT's. A DT sends a message only in response to being polled. Whenever the control line transitions from false to true, each DT synchronizes itself with the message source and clocks-in the first three bits of the message to determine if it is the DT being addressed. When a DT responds to a polling message, it echos its address as the first three bits of the message. The originator of a message controls the state of the control line.

*Direct Memory Access

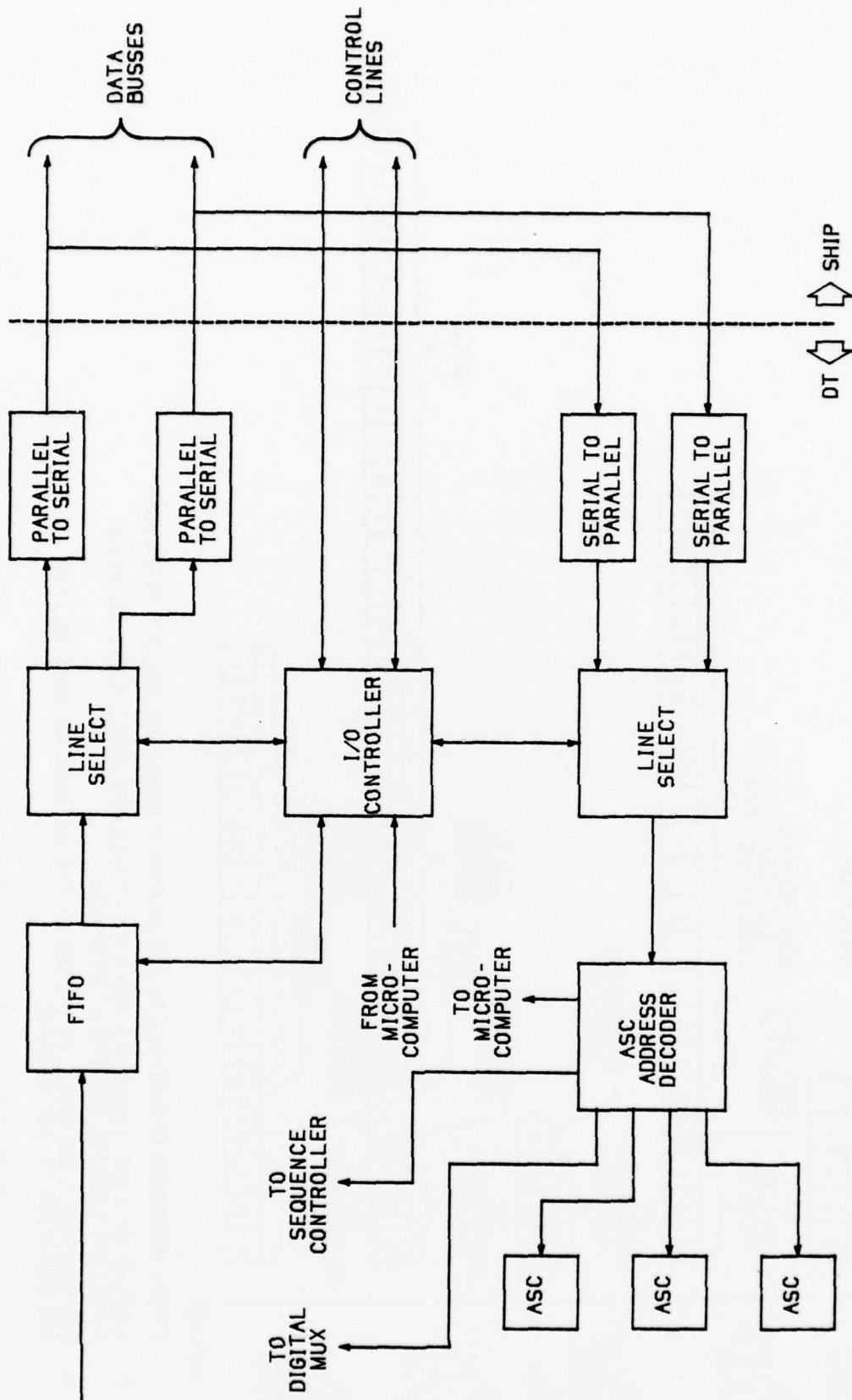

SERIAL I/O
DATA TRANSFER
FIGURE 5

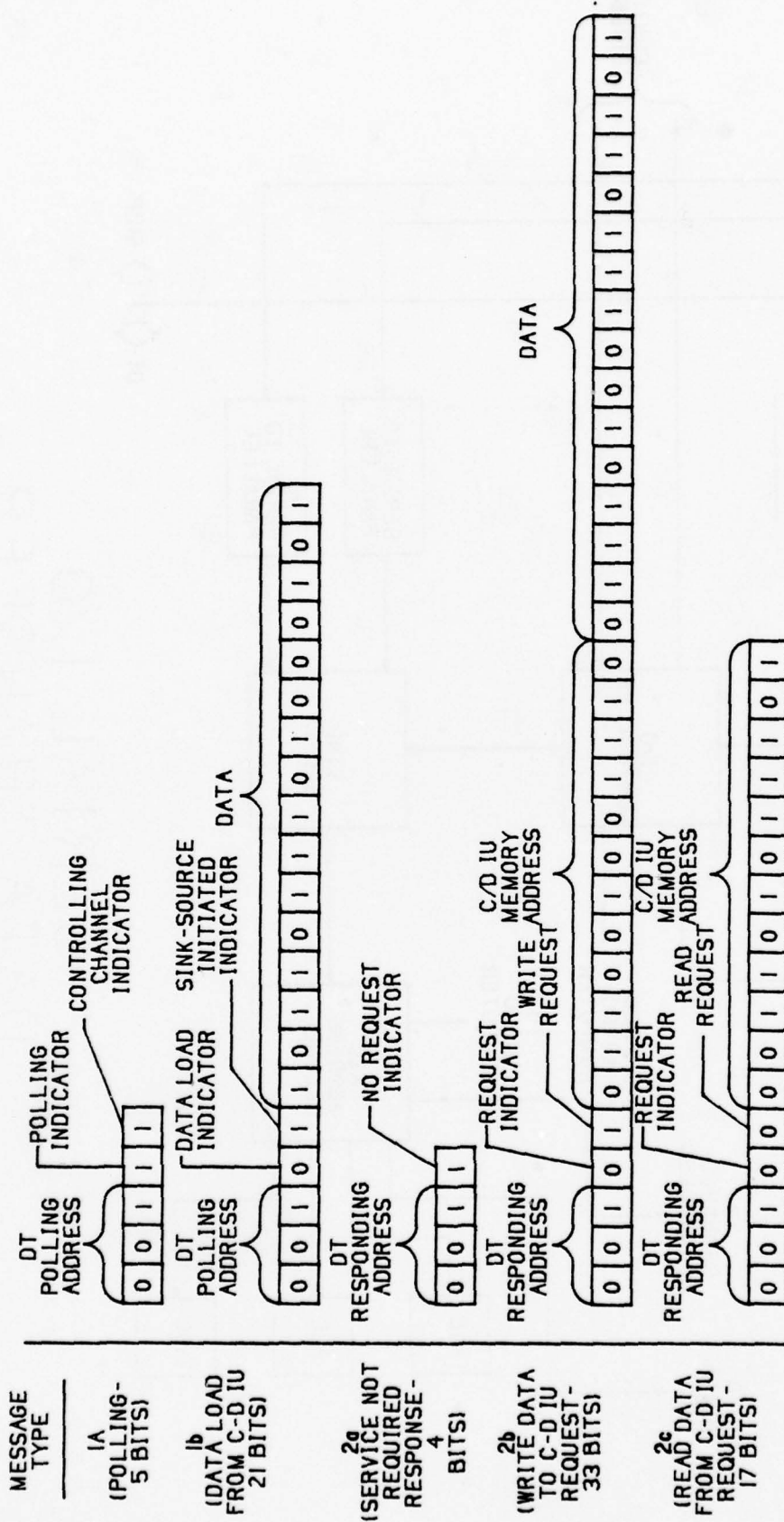

MESSAGE TYPE

1^a (POLLING-5 BITS)

1^b (DATA LOAD FROM C-D IU 21 BITS)

2^a (SERVICE NOT REQUIRED RESPONSE-4 BITS)

2^b (WRITE DATA TO C-D IU REQUEST-33 BITS)

2^c (READ DATA FROM C-D IU REQUEST-17 BITS)

NOTES:

1. TYPE 1 MESSAGES ORIGINATES IN C/D IU. TYPE 2 MESSAGES ARE D/T RESPONSES
2. A DELAY OF 2 BIT-TIMES MIN AND 4 BIT-TIMES MAX SHALL EXIST BETWEEN A POLLING MESSAGE AND THE DT RESPONSE
3. THE CONTROL LINE SHALL BE RAISED BY THE MESSAGE ORIGINATOR, FOR THE DURATION OF THE MESSAGE

SERIAL MESSAGE FORMATS
FIGURE 6

Table I. Serial Message Formats

C/D IU Originated Messages

1. Polling (5 bits)
 - a) 3 MSB's* are DT address
 - b) 4th MSB is polling/data load indicator ("1" = polling)
 - c) LSB** is controlling channel indicator ("1" = channel is control; "0" = opposite channel is control)
2. Data Load (21 bits)
 - a) 3 MSB's are DT address
 - b) 4th MSB is polling/data load indicator ("0" is data load)
 - c) 5th MSB is sink/source initiated request indicator ("1" is sink; "0" is source)
 - d) 16 LSB's are data

DT Originated Messages

1. Service Not Required (4 Bits)
 - a) 3 MSB's are DT address
 - b) LSB is No Request/Request Indicator ("1" = no request)
2. Write Data Request (33 Bits)
 - a) 3 MSB's are DT address
 - b) 4th MSB is No Request/Request Indicator ("0" = request)
 - c) 5th MSB is Write/Read Request Indicator ("1" = write)
 - d) 6th thru 17th MSB are C/D IU memory address
 - e) 16 LSB's are data
3. Read Data Request (17 Bits)
 - a) 3 MSB's are DT address
 - b) 4th MSB is No Request/Request Indicator ("0" = request)
 - c) 5th MSB is Write/Read Request Indicator ("0" = read)
 - d) 12 LSB's are C/D IU memory address

* Most-significant-bit

** Least-significant-bit

The C/D IU sends two types of messages: a 5-bit polling message; and a 21-bit data load message. The data load message is in response to a read-request message from the DT or originated by the C/D IU, as defined by the 5th most-significant-bit of the message.

Data Terminals respond to polling messages with one of three types of messages: a 4-bit message indicating that no service is required; a 33 bit message to write data into the C/D IU (C/D IU memory address and data included); or a 17 bit message to read data from the C/D IU (C/D IU memory address included).

The serial bit rate is one megabit per second utilizing twisted shielded pairs of conductors. Depending on the mix of messages, data can therefore be transmitted or received at greater than 30K words per second on each of the serial busses. A bit-time is one microsecond. A logical "1" is transmitted as an 11/16 microsecond pulse and a logical "0" is transmitted as a 5/16 microsecond pulse.

Each of the data terminals and the interface unit have identical clock synchronization circuitry. This consists of a 16 MHz oscillator, a resettable binary divide-by-16 counter, and logic to divide the one microsecond clock period into 5/16, 1/2, and 11/16 microsecond increments. At the reset time on the control line, this binary counter is reset to zero. The clock in each of the data terminals will therefore be in synchronization with the clock in the traffic controller and phase shifted no more than 1/16 of a clock pulse. Incoming data are examined at pulse fall time to determine if the incoming datum is a "1" or a "0". Because a "1" is 11/16 microsecond wide and the examination time is 1/2 plus a possible 1/16 microsecond, a 1/4 clock time margin exists to properly determine if the bit should be a "1" or a "0"; this allows ample margin for clock drift and signal rise and fall time ambiguities.

The Serial I/O Controller provides synchronizations, decodes the three-bit polling address and determines the controlling channel from polling messages and informs the microcomputer. It also selects the parallel to serial converter for FIFO data routing, encodes the four most significant bits, selects the serial to parallel converter for data routing and accepts a command from the microcomputer to cease transmitting on one of the busses in the event of malfunction. Two parallel-to-serial converters accept data in parallel format from the FIFO and output data in serial format. Each parallel-to-serial converter is dedicated to one of the serial busses with bus selection performed by the I/O Controller. Selection will normally toggle between the two except when operation of one bus is suspended due to malfunction. In addition, two serial-to-parallel converters accept data in serial format from the busses and output data in parallel format to the Actuator Signal Converters and to the microcomputer. Each serial-to-parallel converter includes a parallel register on its output and is dedicated to one of the serial busses.

The ASC address decoder decodes the C/D IU memory address portion of read data messages. This command is held in a latch until the corresponding data load message is received, at which time the data are transferred to the proper destination. One of the addresses is assigned to the microcomputer to enable the transfer of data to it via the serial bus. When the microcomputer address is decoded and the corresponding data load message is received, an interrupt to the microcomputer and to the Sequence Controller is generated. This interrupts the measurement sequence that may be in progress and enables the loading of bus data to the microcomputer via a program transfer.

2.3.3 First-In, First-Out Memory

The 32 word (minimum) by 16 bit FIFO memory is loaded by the microcomputer and unloaded by the Serial I/O Controller. Output messages are formatted in the FIFO exactly as they are transmitted except that the DT responding address is added by the I/O Controller. The FIFO provides a signal to the I/O Controller when data are available and a signal to the microcomputer when it is ready to accept data. The DT master reset clears the FIFO.

2.3.4 Sequence Controller

The Sequence Controller accepts pointer addresses from the microcomputer to initiate the measurement sequence and then sequentially accesses analog and digital mux codes to control switching through the A/D converter and to the microcomputer. It also provides proper switching/settling delays and includes a 16-bit, real-time counter that provides a 10 millisecc period interrupt to the microcomputer. Included in the Sequence Controller is circuitry to interface with the DMA Controller, interrupt the DMA transfer and enable the programmed transfer of data from the C/D IU to the microcomputer. A RAM* is used for control sequence storage rather than a PROM** or a PLA*** to obtain maximum flexibility in the laboratory. This is loaded automatically from the simulation computer, via the microcomputer.

* Random Access Memory

** Programmable Read Only Memory

*** Programmable Logic Array

2.3.5 Microcomputer

This section defines the hardware requirements that are unique to the Data Terminal. Software requirements should be developed during the detail design phase. Selection of the microcomputer type will be based on an analysis of the software requirements for the DT and standardizing with other ASCOP microcomputers. The microcomputer should perform the following tasks in real time:

- Initiate each measurement sequence by setting up the DMA controller and sending the starting address of the Sequence Controller memory that defines the sequence (pointer address).
- Calculate rate and acceleration on selected measurements.
- Perform sensor failure detection testing on selected measurements.
- Format data for the FIFO memory. Define C/D IU memory locations into which data is written or from which data is read. Initiate the transfer sequence by setting up the DMA controller.
- Accept control information from the C/D IU via the Serial I/O Controller, including whether channel A or channel B shall provide the actuator control signals.

A RAM is used for main program storage rather than a PROM to obtain maximum flexibility in the laboratory. A bootstrap program is stored in a PROM to accomplish automatic loading of the main program from the simulation computer when power is turned on. The microcomputer hardware consists of the central processing unit, memory, DMA controller, and circuitry to interface with the functions as shown in Table II.

Table II. Microcomputer Interface Functions

Interrupts

10 millisecc periodic from Sequence Controller

Terminal Count from DMA Controller

Data Available from C/D IU (from ASC address Decoder)

Power turn-on (also generates master reset for all DT control logic).

Data through Digital Mux

Program load from simulation computer

Simulation data from the simulation computer

Simulation data from the simulation computer, through the SCU's/A/D Converter.

PM/FL measurements on DT resident functions

Real-time register from Sequence Controller

Data from C/D IU, through Serial I/O

Channel A or B in control from C/D IU, through Serial I/O

FIFO

Ready to accept data signal, from FIFO

FIFO empty signal, from FIFO

Formatted data, to FIFO.

Sequence Controller

Program load of sequence controller, from simulation computer.

Pointer address to Sequence Controller

Ready to accept data signal, from Sequence Controller.

2.3.6 Digital Multiplexer

The digital multiplexer provides for the gating of data to the micro-computer. Data word length is 16 bits and the addressing structure can accommodate 127 words. The digital multiplexer is modularly expandable to 127 words.

2.3.7 Analog-to-Digital Converter

The Analog-to-Digital converter performs the voltage measurements of the various analog sensor conditioning units, in addition to other DT voltages for PM/FL. The measurement range is approximately ± 10 vdc. Output data is 13 bits in length thus providing resolution of 2.5 millivolts. Two's complement binary coding are provided.

2.3.8 Analog Data Select

The analog data select provides for the switching of signals to the A/D converter. The addressing structure accommodates 127 signals. The input voltage range of these signals is approximately ± 10 volts peak-to-peak. The dynamic response and accuracy should be compatible with the A/D converter selected in the detail design phase.

2.3.9 Sensor Conditioning Units

SCU's provide the interface between the Data Terminal's switching/measuring circuitry and the ships sensors. They condition the signals to the ± 10 vdc range of the A/D convertor and to the logic levels of the digital mux for discrettes. The SCU's are also used to condition DT power supply outputs and other PM/FL signals to the A/D converter range.

2.3.10 Actuator Signal Converters

ASC's provide the interface between the Data Terminal's digital control circuitry and the ships actuators. Output signals include synchros, dc-voltages, and various levels of switch closures.

2.4 COMMAND/DISPLAY INTERFACE UNIT

The C/D IU, as shown in Figure 7, provides the common data storage for ships data and also for processed data that is required by other users. This is a highly flexible structure because panels (users) communicate with each other (and with the ship) via the C/D IU. Therefore, special wiring between panels is not required. Users communicate with the C/D IU via a parallel bus. The C/D IU provides traffic control for the parallel bus and for the serial busses to the Data Terminals.

Sources of data identify memory locations in which they desire to write data. Sinks of data identify memory locations from which they desire to read data. Therefore, the C/D IU merely responds to Read/Write requests and does not require programming to control data rates, sources, or destinations. Revisions to the above are accomplished by revising the software of the applicable DT or user.

2.4.1 C/D IU Control

Figure 7 shows C/D IU control functions in addition to data flow. Communication with the Data Terminals occurs under control of the Serial I/O Controller. When a service request message from a DT has been accumulated in a parallel buffer, a flag is set. The Memory

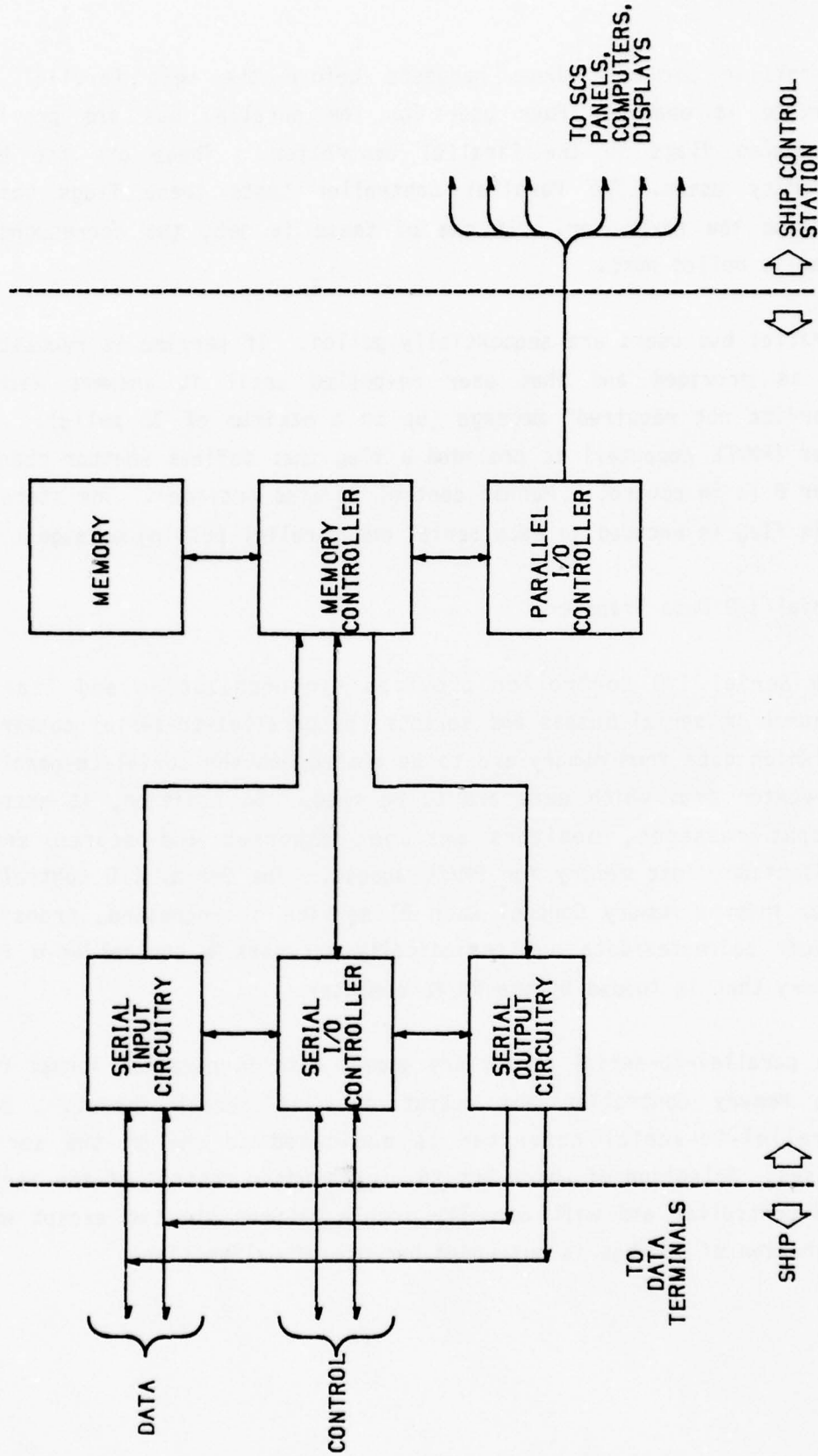

COMMAND/DISPLAY INTERFACE UNIT (HALF)
BLOCK DIAGRAM
FIGURE 7

Controller services these requests before the next Parallel I/O service is enabled. Four users on the parallel bus are provided dedicated flags in the Parallel Controller. These are the high priority users. The Parallel Controller tests these flags before polling the next user. If one of these is set, the corresponding user is polled next.

Parallel bus users are sequentially polled. If service is requested, it is provided and that user re-polled until it answers with a "service not required" message (up to a maximum of 32 polls). One user (PM/FL computer) is provided a flag that defines whether channel A or B is in control. Manual control is also provided. The state of this flag is encoded in each serial and parallel polling message.

2.4.2 Serial I/O Data Transfer

The Serial I/O Controller provides synchronization and traffic control of serial busses and selects the parallel-to-serial converter to which data from memory are to be routed and the serial-to-parallel converter from which data are to be read. In addition, it encodes output messages, monitors message responses and stores error indications into memory for PM/FL access. The Serial I/O Controller also informs Memory Control when DT service is requested, transfers memory addresses/data and periodically accesses a control word from memory that is loaded by the PM/FL computer.

Two parallel-to-serial converters accept data in parallel format from the Memory Controller and output data in serial format. Each parallel-to-serial converter is dedicated to one of the serial busses. Selection of which bus to use is under control of the Serial I/O Controller and will normally toggle between the two except when operation of one bus is suspended because of malfunction.

Two serial-to-parallel converters are provided which accept data in serial format from the busses and output data in parallel format to the Memory Controller. Each serial-to-parallel converter includes a parallel register on its output. Each serial-to-parallel converter is dedicated to one of the serial busses.

2.4.3 Parallel I/O Data Transfer

Figure 8 defines the parallel message formats. Parallel users and the C/D IU communicate via 24 lines consisting of the following:

- 5 lines - user address
- 1 line - polling/data load
- 1 line - control (strobe)
- 16 lines - data
- 1 line - 1 MHz clock

The C/D IU acts as the traffic controller by polling the users. The philosophy for the parallel protocol is similar to that for the serial except 1) the control line is controlled only by the C/D IU, 2) user addresses are echo'd only on "no service required" messages, 3) block transfer modes are provided, and 4) all message are sink initiated. The C/D IU originates two major types of messages: a polling message and a data load message. The data load message is in response to a read-request message from the user. Coding of the polling/data line defines the type of message.

A user sends a message only in response to being polled. On the false to true transition of the control line, each user decodes the address lines to determine if it is the user being addressed. Users respond to polling messages with one of three types of messages: a "no service required" message, which includes an echo of the user address; a message to write data into the C/D IU (C/D IU memory address and data included); or a message to read data from the C/D IU (C/D IU memory address included).

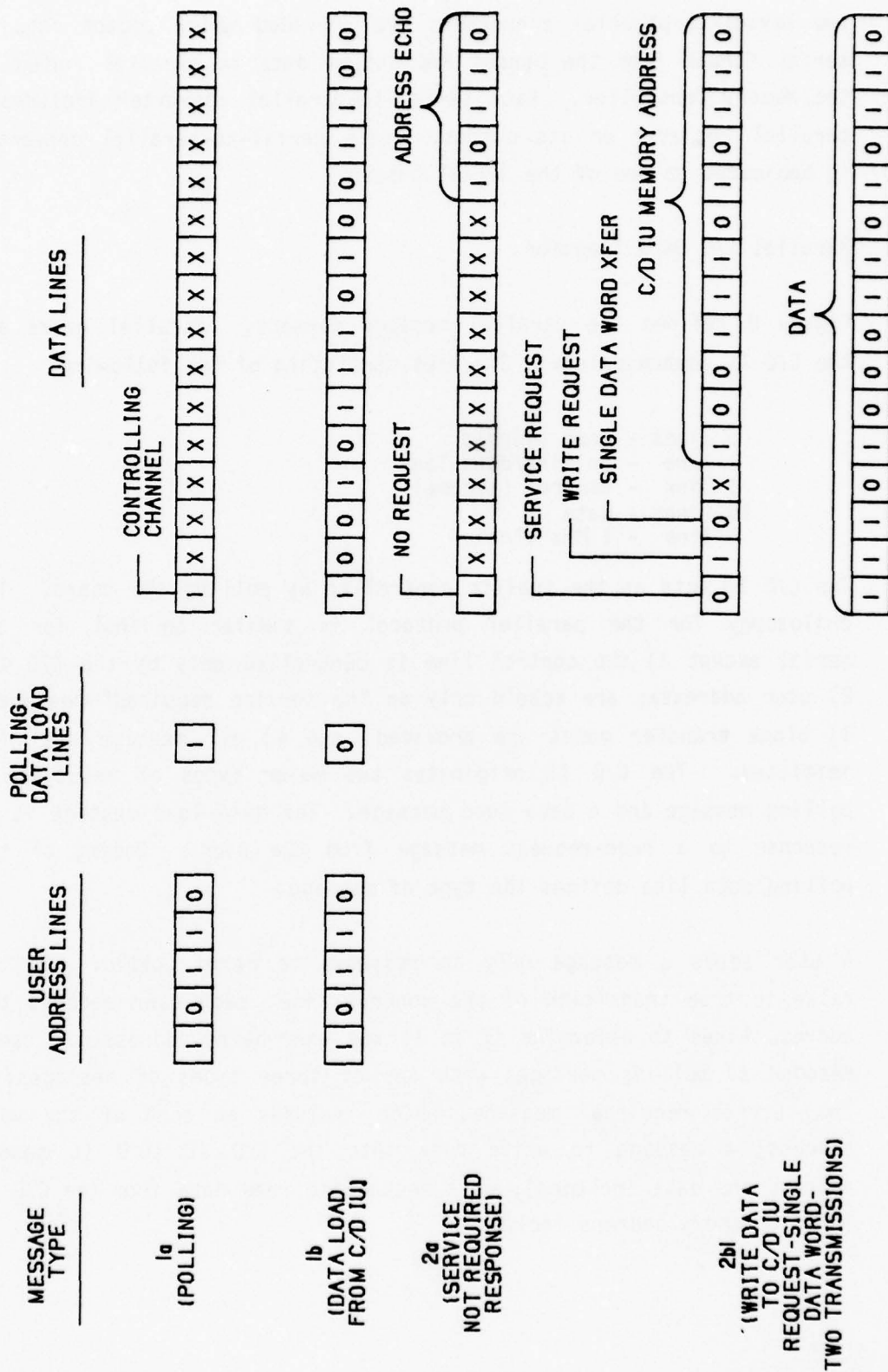

PARALLEL MESSAGE FORMATS

FIGURE 8

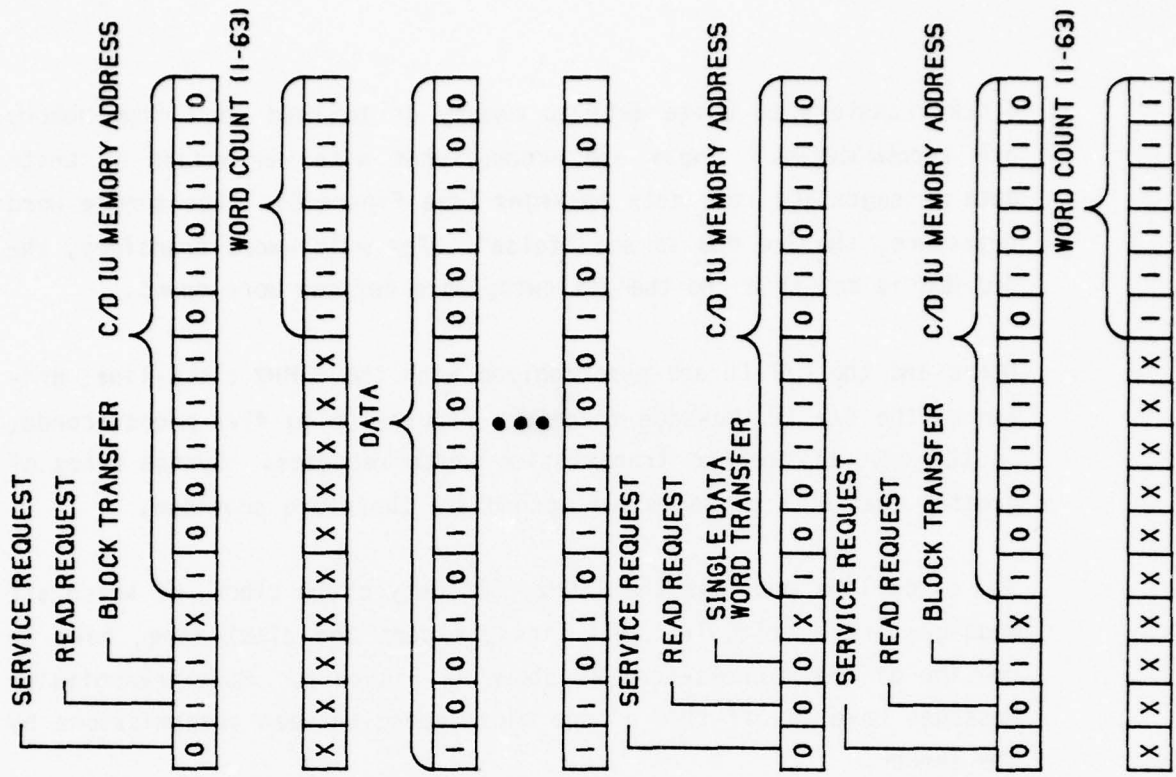

2b2
 (WRITE DATA
 TO C-D IU
 REQUEST-BLOCK
 TRANSFER-N + 2
 TRANSMISSION WHERE
 N = BLOCK SIZE)

2c1
 (READ DATA
 FROM C-D IU
 REQUEST-SINGLE
 DATA WORD)

2c2
 (READ DATA
 FROM C-D IU
 REQUEST-BLOCK
 TRANSFER-
 TWO TRANSMISSIONS)

FIGURE 8.1

Block transfers to write data to memory or to read data from memory are accommodated. These are accomplished with variations of write data messages and read data messages (see Figure 8). For single word transfers, the 3rd MSB is set "false". For multi-word transfers, the 3rd MSB is set true and the following word defines word count.

Users and the C/D IU are synchronized with the 1 MHz clock-line, driven by the C/D IU. Message transfers require up to five microseconds, in the case of the two transmission write requests. System rates of greater than 200K messages per second are therefore provided.

The clock line provides the 1 MHz, 50% duty cycle clock, of which all messages are a multiple. All lines, except the clock line, have an on-time of one micro-second as shown in Figure 8. Multitransmission messages have an off-time of one microsecond between transmissions by the sender.

The User Address, Polling/Data Load, and Data Lines are read by each user upon the false-to-true transition of the control line. Formats requiring multitransmissions from the C/D IU occur at one microsecond on, one microsecond off, time intervals. Formats requiring multitransmissions from a user occur at one micro-second on, one micro-second off, time intervals. As shown in Figure 9, phasing is provided to accommodate strobing by users on the leading edge of the control line and the applicable clock pulse, and the strobing by the C/S IU on the trailing edge of the applicable clock pulse.

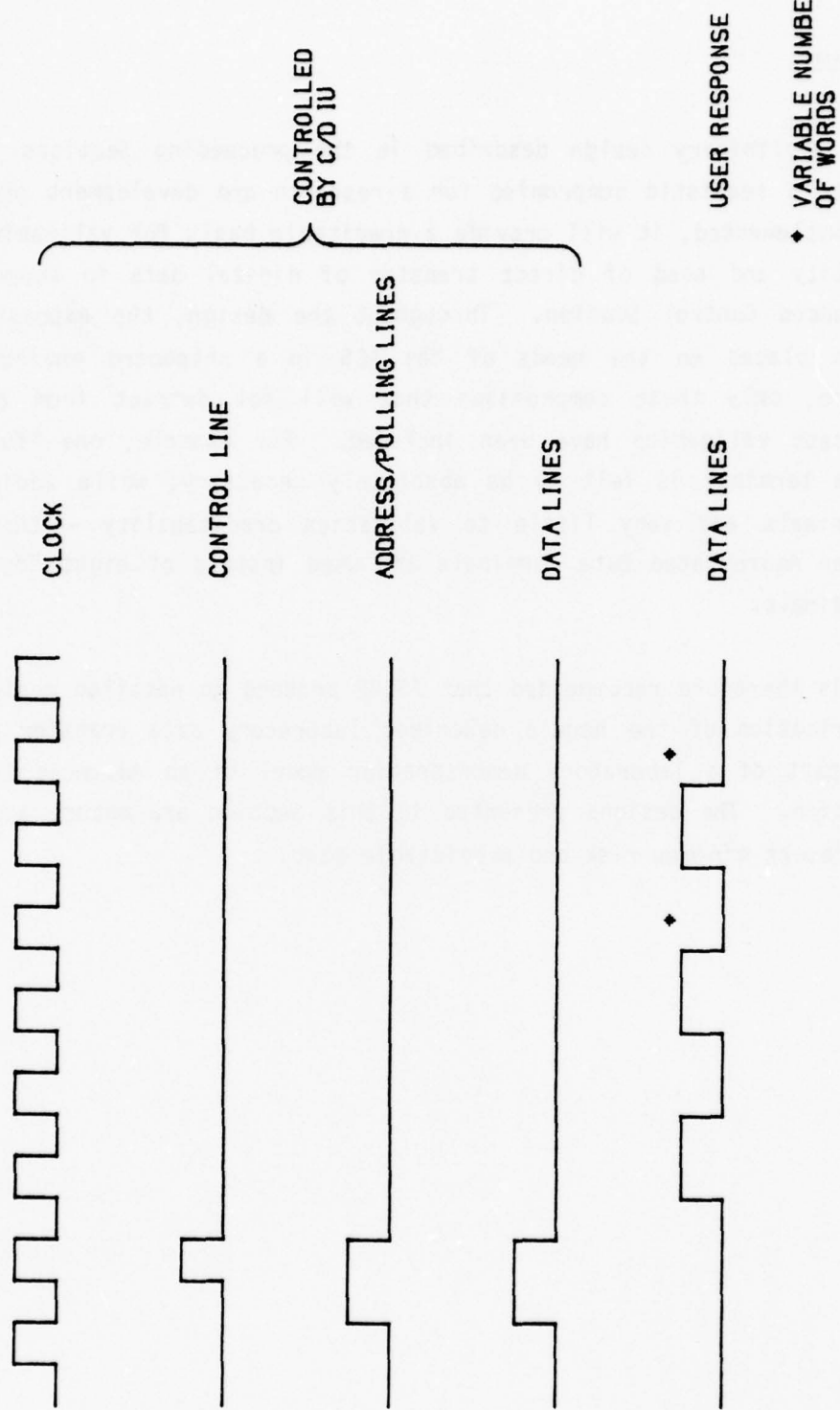

PARALLEL MESSAGE RELATIVE TIMING

FIGURE 9

2.5 SUMMARY

The preliminary design described in the preceding Sections represents a realistic compromise for a research and development program. If implemented, it will provide a creditable basis for validating the utility and need of direct transfer of digital data to support an Advanced Control Station. Throughout the design, the emphasis has been placed on the needs of the ACS in a shipboard environment. Hence, only those compromises that will not detract from a full concept validation have been included. For example, one "full-up" data terminal is felt to be absolutely necessary, while additional terminals add very little to validation creditability - therefore seven Abbreviated Data Terminals are used instead of eight "full-up" terminals.

It is therefore recommended that ASCOP proceed to detailed design and fabrication of the herein described laboratory data transfer system as part of a laboratory demonstration model of an Advanced Control Station. The designs presented in this Section are mature and thus represent minimum risk and predictable cost.

3.0 MULTIFORMAT DISPLAY

During Task VI, Part I, numerous discussions were held relative to the role of multifformat displays for an ACS. As a result, sub-task 3 of Task VI, Part II was initiated with the primary objective of investigating multifformat displays capable of near universal adaptation to a broad and diverse family of ship control station shipboard usage. In addition, integral to this task was the objective evaluation of the best available technology to accommodate the primary goal. Being cognizant of this premise, an early assessment of the available technology narrowed the candidates to A-C plasma and cathode-ray tube. In the months following that early assessment, prototype electroluminescent display panels reached the marketplace. cursory evaluations led to the conclusion that EL technology was also a viable consideration for the multifformat display implementation. While performance served as the primary determinant in the selection process, other factors such as availability, operability, reliability and maintainability were rigorously weighed. This Section reports the results of the multifformat display investigation with sub-sections devoted to mechanization tradeoffs, candidate technologies, mechanization approaches, interface and modularization. Recommendations are presented in Section 4.4.

The multifformat display provides for the integrated display of essential steering and diving control information and presents these data in the primary viewing area of the operator. Provisions exist for the supplementary presentation of supporting data regarding system status. The supplemental data, as well as primary modes, are accessible via interactive cueing and control. The selectable modes and formats permit the operational use of either manual or auto-aided control. The organization and mechanization of the multifformat display satisfies the requirements of an Information Management Function.

3.1 MECHANIZATION TRADEOFFS

The primary tradeoff in the selection of a display involves an assessment of which display technology best fits the information and action requirements. The following table depicts a general summary of the top level display requirements derived from the analysis presented in Appendices E and F and discussed further in Section 4.

Table III. Top Level Display Requirements		
Characteristic Category	Magnitude	
	Average	Extreme
Active area	9 inch diagonal	9 inch diagonal
Data density	20 lines of alphanumeric text; 20 characters/line plus graphics	30 lines of alphanumeric text; 50 characters/line plus graphics
Update rate	2 times/min	5 times/sec
Amount of changing information	100 characters	400 characters
Total number of format	14	20 (projected growth)
Type of font	3 sizes; double & single line	3 sizes; double & single line
Type of graphics	straight line & mimics (submarine shape)	Full graphics including conics (projected growth)

3.1.1 Cathode-Ray Tube Graphics

There are two satisfactory approaches to the mechanization of the CRT* display: raster graphics and stroke writing. The raster graphics technique converts random input data into a television (TV) format so information can be displayed on a standard TV monitor. Figure 10 is a generalized depiction of the mechanization. The input can be from a digital computer, analog sensors (pressure, temperature, etc.) or manual input (i.e., keyboard controls, joystick, etc.) The output is standard composite video. Data are displayed as overlapping dots on a TV monitor.

3.1.1.1 Raster Graphics

In raster graphics, input data tell the display generator micro-processor what to do. The display generator bit map memory contains one bit of storage for each possible dot on the CRT. The micro-processor loads "ones" into the appropriate memory location in the bit map memory in accordance with the desired character format. Once loaded in memory, scanning circuits read out the bit map memory in synchronism with the TV lines being scanned on the monitor. Every "one" stored in memory intensifies the CRT beam to write a dot. The memory is continually read out and displayed on the CRT at a high-speed refresh rate of typically 25-30 times per second. A typical system will have from 512 to 1024 bits of memory (dots on the CRT) in both the X and Y axis.

In a typical application, unchanging or slowly moving data (such as trim and ballast information) are input to the raster graphics generator from mass storage (disk, tape, PROM, etc.) These data are written into memory and displayed as background. Next, changing

*Cathode-ray tube

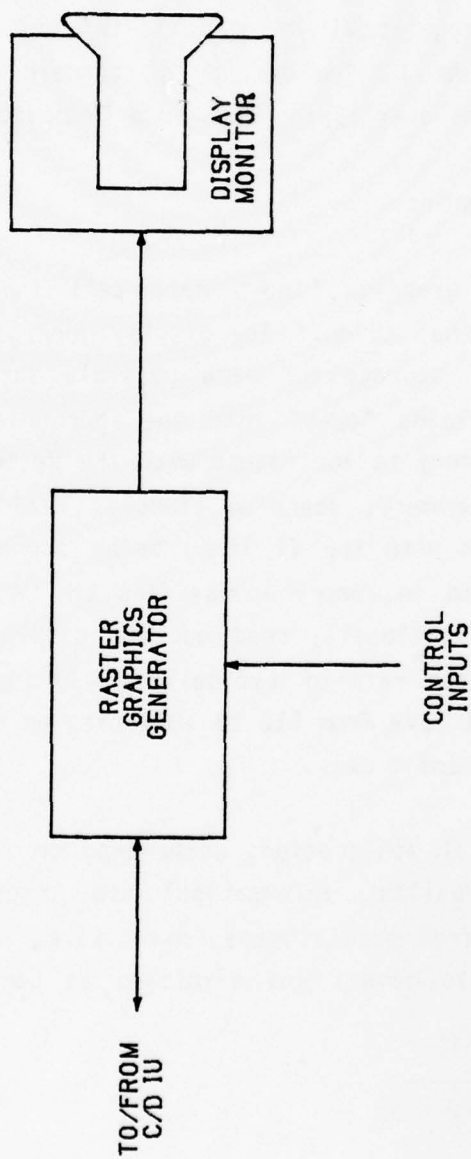

RASTER GRAPHICS DIAGRAM

FIGURE 10

data (ship's depth, speed, attitude, etc.) are input from a computer, written into memory, and superimposed on the background. By judicious use of symbology, categories of data can be separated to be visually discernible to an operator.

Five modules, boards or partitions are typical elements of a raster graphics generator; Figure 11 is a representation of the organization. The controller module generally uses a microprocessor to control the overall operation, including communication with a host computer and with controls, as well as organizing, formatting, listing and manipulating the data being displayed. The graphics I/O module buffers input data until the microprocessor (vector/ alphanumeric generator) can handle the data. The graphics I/O module also generates and outputs composite video in the proper format for eventual display. The microprocessor, using structured algorithms, computes and plots all points required to draw a vector or alphanumeric, then writes the data into the refresh memory locations. The refresh memory contains a bit map of the display, i.e., one bit of storage for each possible dot location on the monitor. The timing and control module supplies all the clocking and sync pulses required for the generators.

3.1.1.2 Stroke Graphics

The stroke graphics approach generates characters and symbols by chaining short vectors together. The symbol/character set is stored in PROMS and therefore is readily changed. Figure 12 depicts a typical stroke graphics system. The current technique is to configure a bus-organized unit of modular components plugged into a digital bus, with each modular assembly responsible for performing a specific function. The heart of the unit is the data processor which is connected to system/computer inputs and controls or outputs to

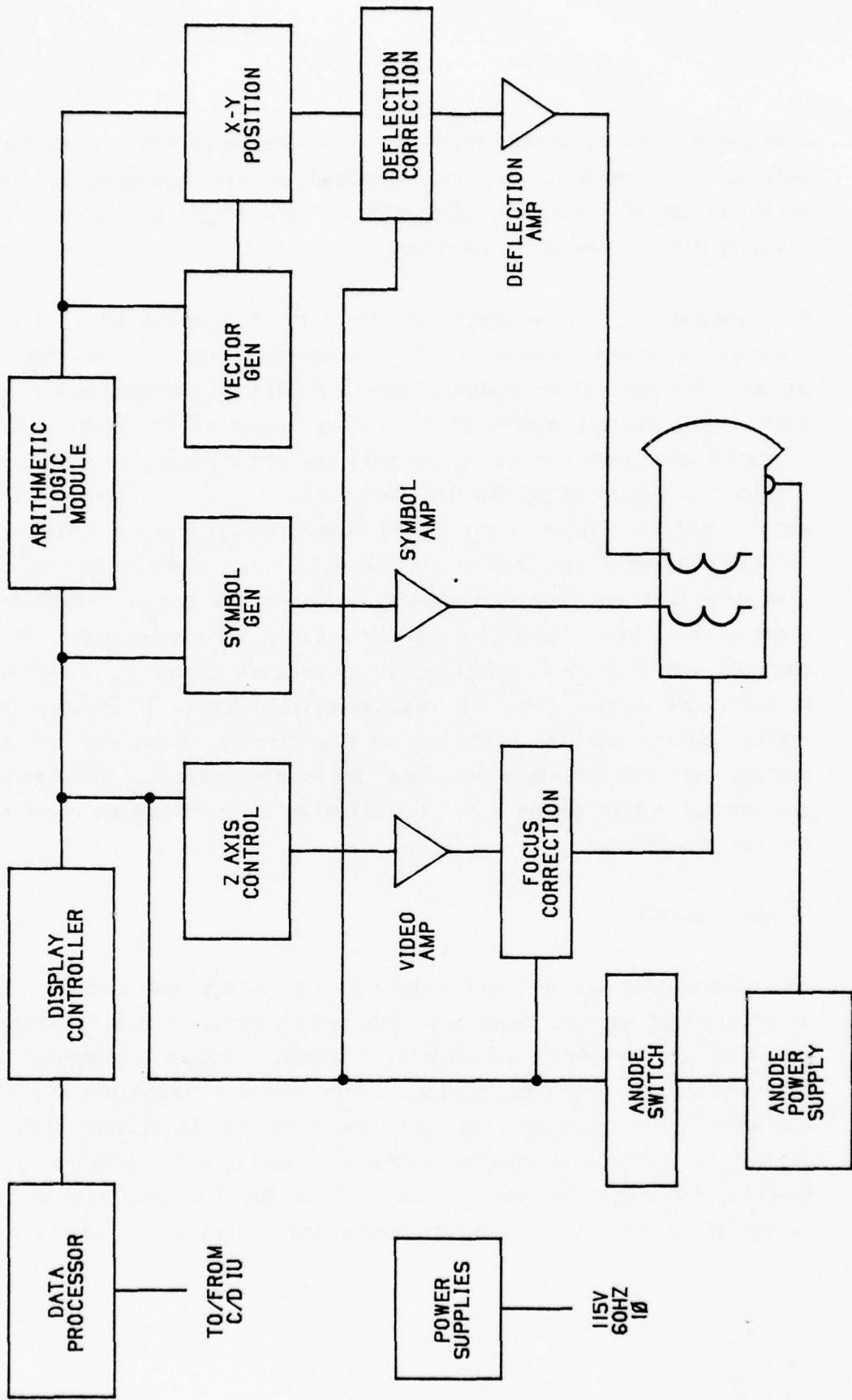

STROKE GRAPHICS DIAGRAM

FIGURE 11

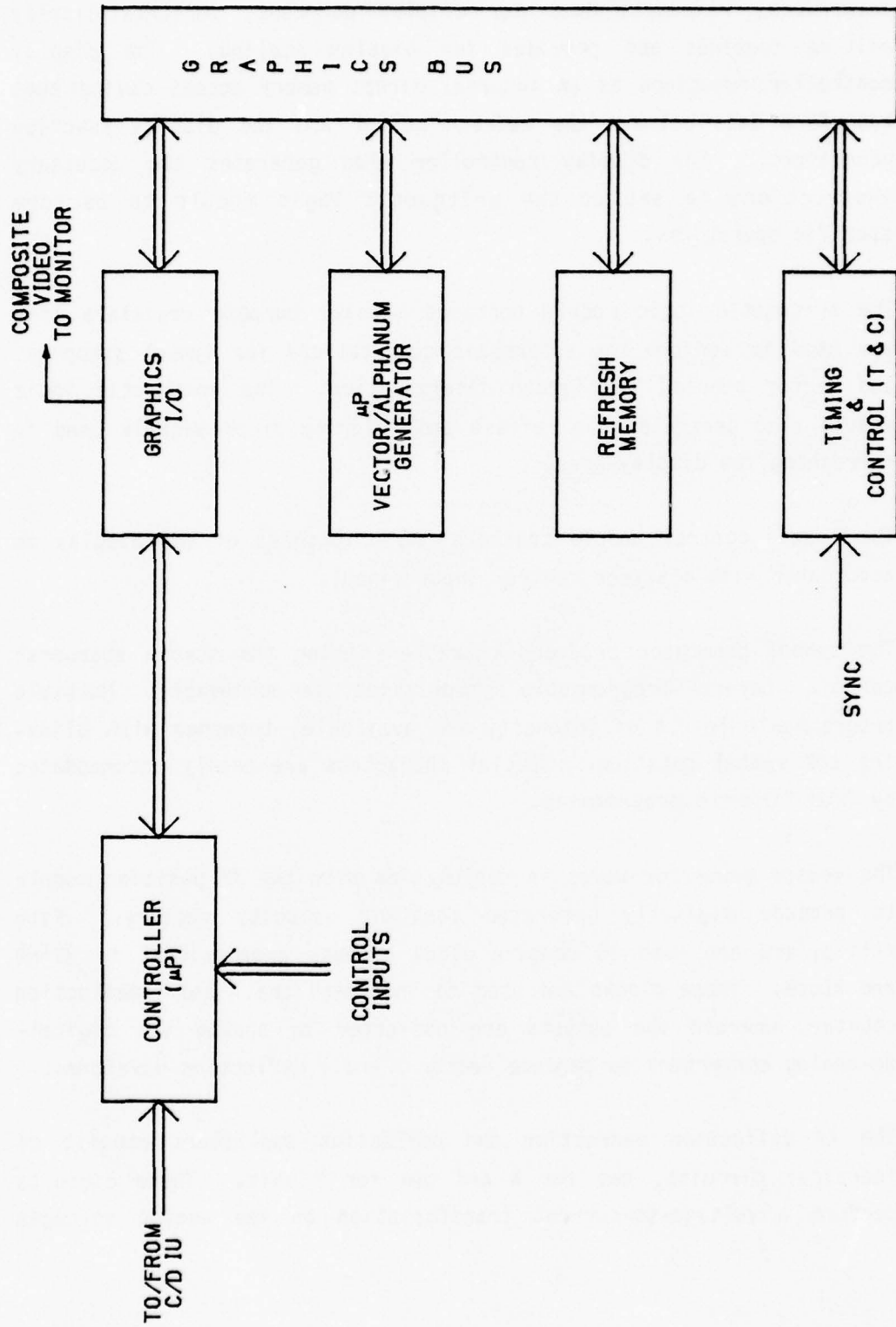

RASTER GRAPHICS GENERATOR DIAGRAM

FIGURE 12

peripherals. The data processor services all I/O and peripheral interrupts, reformats data for display purposes, performs display editing routines and provides for display scaling. The display controller functions as an internal direct memory access device that transfers data between the refresh buffer and the display function generators. The display controller also generates the necessary instructions to set up the arithmetic logic module to perform specific operations.

The arithmetic logic module contains special purpose registers that are used to perform the arithmetic computations for symbol stepping, and vector bearing and length determination. The arithmetic logic module also generates the refresh and priority clock signals used in refreshing the display area.

The Z axis control module controls the brightness of the display in accordance with a screen control input signal.

The symbol generator produces characters using the stroke starburst method. Several programmable symbol sizes are achievable. Multiple programmable levels of intensity are available, together with blinking and symbol rotation. Special characters are easily accommodated by PROM firmware programming.

The vector generator works in conjunction with the XY position module to produce digitally generated constant velocity vectors. Rate multipliers are used to compute clock outputs proportional to $R\sin\theta$ and $R\cos\theta$. These clocks are used to increment the X and Y deflection counter, wherein the outputs are converted to analog via digital-to-analog converters to produce vector X and Y deflection waveforms.

The XY deflection correction and deflection amplifiers consist of identical circuits, one for X and one for Y axis. These circuits perform a voltage-to-current transformation on the analog voltages

from the XY deflection counter; these currents are applied to the yoke. Sense signals for application to the dynamic focus are developed also by the deflection circuits; these signals are used to maintain beam focus across the entire display surface. Inputs to the XY symbol deflection amplifiers are received from the symbol generator and a voltage-to-current transformation conditions the signals for application to the symbol deflection yoke.

3.1.2 Flat Panel Displays

The flat panel displays, like the CRT, have two differing approaches for the generation of graphics and text. However, the differences are prompted by the characteristics of the technologies. For instance, the plasma display has a characteristic called inherent memory. More specifically, once a dot or cell has been illuminated and discharge exists, the sustaining signal will cause this cell to maintain discharge and photon emission until it is intentionally erased. This feature precludes any simple approach to driving the plasma display in a raster mode. The straight forward raster drive electronics relies on the periodic decay of the cell or phosphor following electron excitation. In the case of plasma, this does not occur, thus the plasma mechanization requires that the display operate in a random vector graphic mode. Herein, each cell is turned on and off, as the display format requires, to form the desired image. There is no sequential scan of line by line to determine if information is present or not. Each cell has a specific XY address and is so selected and addressed. However, it is possible to link the excitation of successive dots in a predetermined pattern once an initial or starting point has been selected. The display generator is mechanized on this basis. Coded inputs or commands to the display generator will cause the address selection to increment or decrement in X and Y position as the symbol or character may require. Figure 13 is a block diagram depiction of a flat panel display unit.

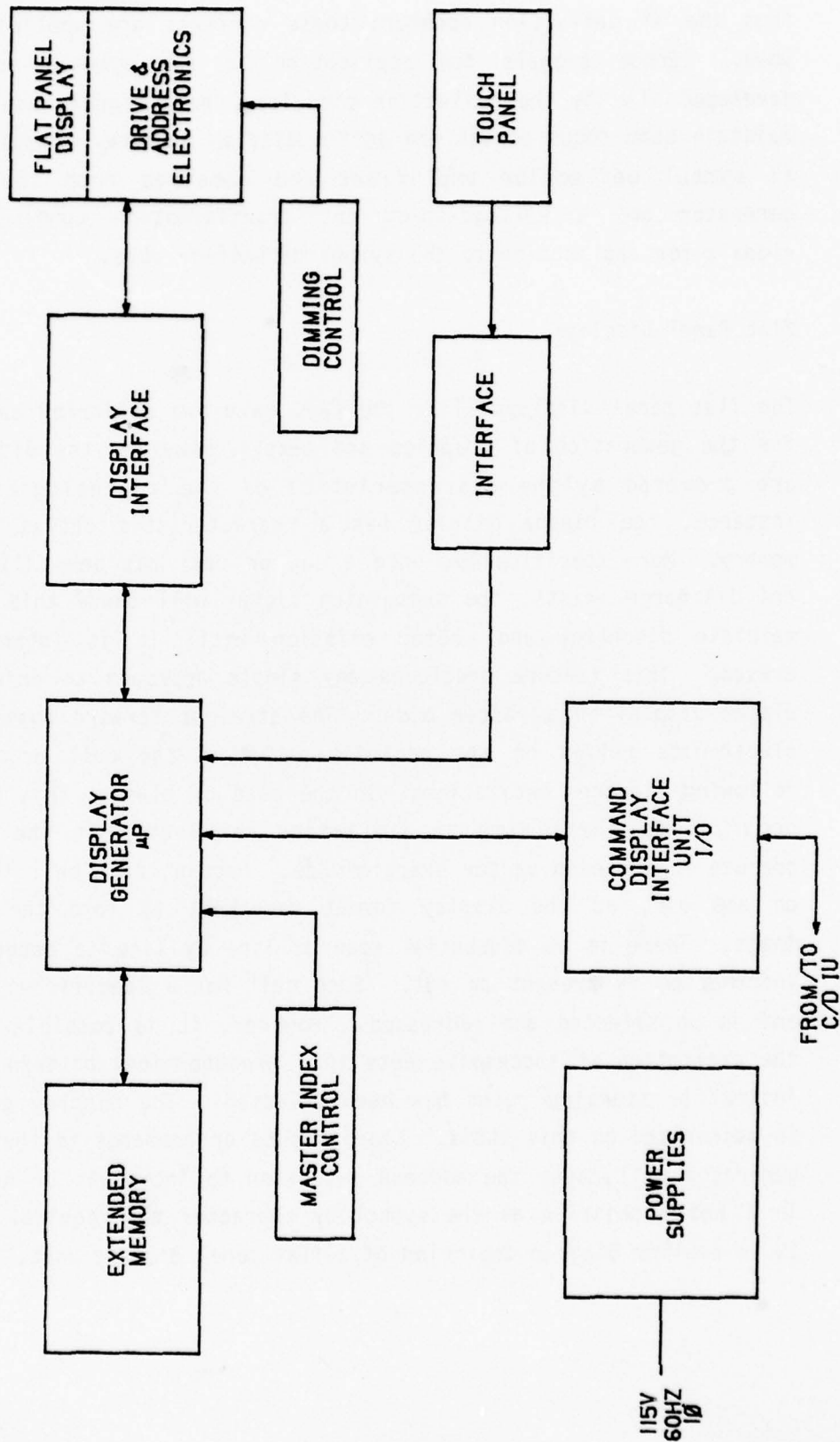

FLAT PANEL DISPLAY DIAGRAM

FIGURE 13

Current practices use a microprocessor, integral to the display generator, to control the functional interfaces between the display panel, touch panel and control inputs as well as the central processor. The microprocessor is also a multi-mode character vector generator that converts the display input code to the signal sequences required to drive the display. Predetermined or fixed data formats may be stored in the extended memory. These are called up and selected via the touch panel overlay. An electromechanical control is provided to permit selection of a master index of display formats which are each selectable using the touch overlay.

3.1.3 Touch Overlay Control

The touch overlay panel is a light beam position encoder. A means is provided for transmitting and detecting the address of interrupted light beams. The device utilizes paired light beam sources and detectors in a crossed light beam grid (X - Y axis) with each source pair being sequentially strobed. The scanning cycle time is compatible with the human reaction times involved. Upon detection of beams interrupted by an obstacle, such as a finger, the associated address is transferred to a data processor and associated program logic or action is initiated. The position encoder is fast enough to detect quick touches, and yet avoid the undesired transmission of redundant address information. Arrays of 32 x 32 elements are available with higher resolution possible. The light sources are light-emitting diodes emitting in the infrared region; thus, providing immunity to ambient light noise problems. Phototransistors are used as detectors. Figure 14 is a block diagram of the touch panel mechanization approach.

Simulated keyboards can be depicted on the display and activated by way of the touch overlay. Also, a menu of display modes and formats can be presented via the master index with sub modes resulting in initial or top level mode selection. In general, any system mode or function can be controlled through use of the combined display and touch overlay scheme.

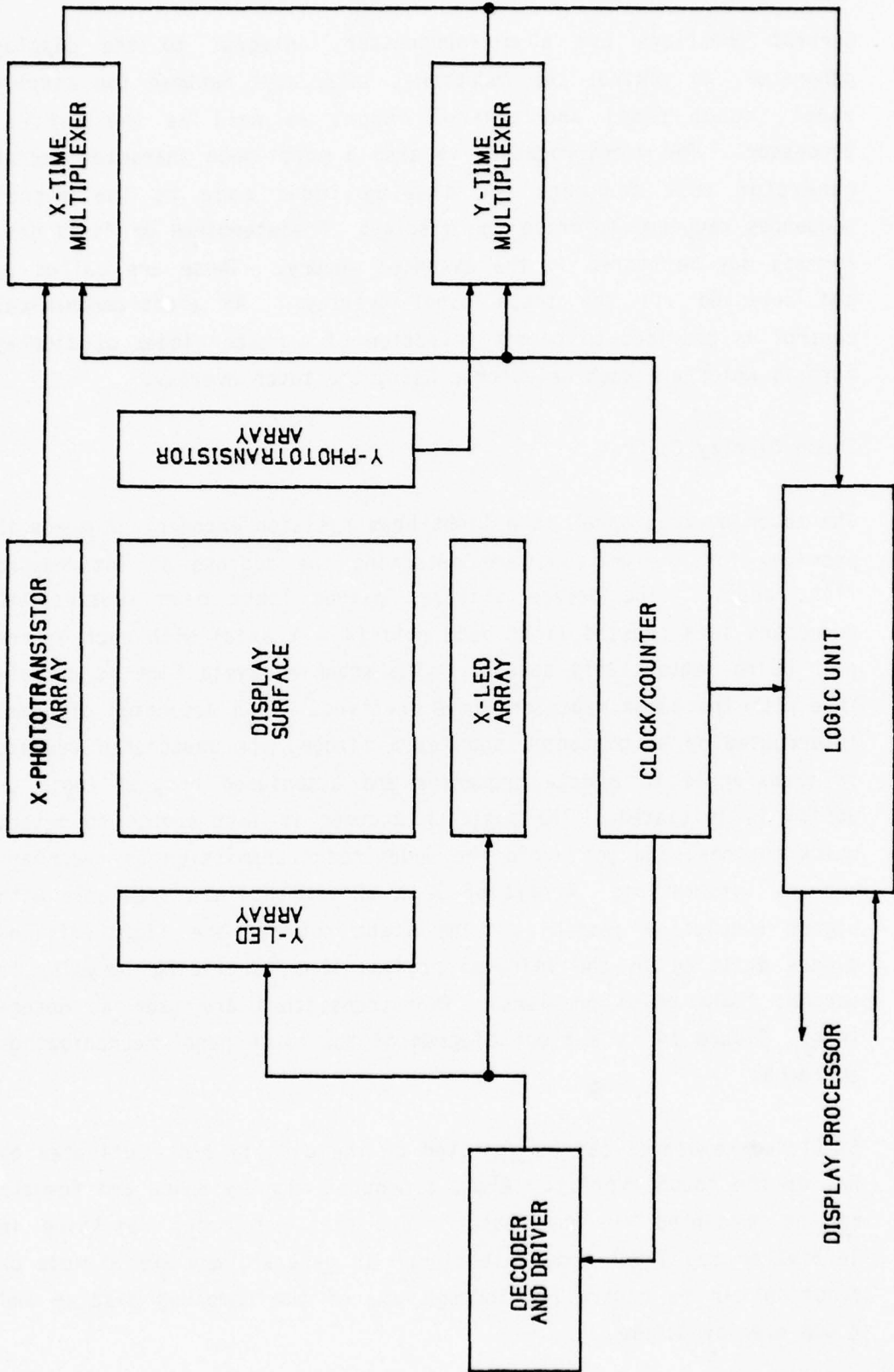

TOUCH PANEL BLOCK DIAGRAM

FIGURE 14

3.1.4 Electroluminescence (EL)

The EL flat panel display differs from the plasma flat panel display in terms of the drive/address electronics. EL may use either a raster scan or random address mechanization. In both instances a refresh memory is required as used with the CRT.

3.2 CANDIDATE TECHNOLOGIES

Recent developments in display technology have brought forth a number of new and promising display techniques. However, most of the developments are as yet laboratory curiosities or they are suited only for small scale numeric and alphanumeric presentations. Therefore, the essential characteristics required by the multiformat display are found only in the CRT, plasma and EL displays.

3.2.1 Technology Overview

Cathode-Ray Tube devices currently satisfy a wide variety of shipboard display requirements including those associated with raw sensor video display, processed or synthetic sensor display, tactical data display and status display. The technology represented by the CRT is mature, in that widespread use of CRT's and a general improvement of CRT technology has taken place over a thirty year period, with the most recent advance being a high-brightness color CRT. The result is a set of displays offering a relatively complete spectrum of capabilities to the extent permitted by the intrinsic physics and characteristic geometry of the CRT device. Presently, CRT's are produced in a wide range of screen sizes with output parameters encompassing a broad span of potential applications.

Plasma displays are the product of a so-called emerging technology. To date, plasma display devices have seen only limited use in the military environment. However, they have been full MIL qualified, including shock and vibration. Such applications as data terminals

and system status monitors have been realized for both land based and shipboard environments. Several production configurations are available from a small family of manufacturers.

Similar to the plasma display, including shock and vibration qualification potential, electroluminescent displays are classified in the emerging technology category. However, EL display development lags considerably behind the plasma display development. Significantly, the intrinsic characteristics of the EL displays give promise to much broader potential use than found in the plasma display.

The minimum essential requirement of a display device, in any application, is the reproduction of information received from a sensor, processor or control to the level of fidelity required by that application. The display device must have the inherent capability to reproduce or present information with adequate resolution (elements per unit area), number of discernible states per element (gray scale) and the ability to present information at the desired rate (frame rate). However, the satisfaction of these information output requirements will affect other important display characteristics such as brightness, linearity, contrast, uniformity, and spot size because of the typical interrelationships of display parameters.

3.2.1.1 Cathode-Ray Tube Technology

The CRT is an analog device. A contiguous layer of phosphor is deposited on the screen which functions as a target for an electron beam which is formed by an electron gun (cathode) assembly. The electron beam, upon striking the phosphor, causes photon or light emission. Writing on the screen is accomplished by means of accelerating and deflecting the electron beam enroute to the screen; grids, yokes and anodes are employed in the generation and control of the resulting display presentation characteristics. The interaction and relationship of the CRT elements, in concert, function to determine the realized levels of writing rate, brightness, resolution, linearity, spot size and other display describing functions.

3.2.1.2 Plasma Display Technology

The plasma display panel is a digital device. A contiguous layer of gas is hermetically sealed between two glass plates. A pattern of electrodes are deposited on the enclosed surfaces of the glass plates. Layers of dielectric protect the electrodes from direct contact with the gas and possible erosion due to ion bombardment. Opposing electrodes are supplied an electrical potential difference of sufficient magnitude to cause ionization and discharge within the gas between the two electrodes and thus an emission of photons or light results. The resolution of a plasma display panel is a function of the electrode spacing. Currently, panels are available with electrode spacing of 60 lines per inch; laboratory models have reached 84 lines per inch. Linearity and contrast are primarily functions of the physical construction techniques and manufacturing processes. Pseudo shades of gray may be achieved by spatial addressing schemes. Another method of achieving levels of gray is by controlling the period of emission of individual cells within a frame period. This is a function of the associated logic and panel drive electronics.

3.2.1.3 Electroluminescence Display Technology

The electroluminescent display panel is a digital device. Early EL panels used powdered phosphors; the current EL panels are TFEL* displays. The TFEL display panel consists of a glass substrate on which, through a series of vacuum depositions, the solid state, thin film, optically active structure is made. The panel is constructed with three layers, namely, an active layer sandwiched between two insulating layers. Protection of the device from humidity is essential; the outer insulating layer satisfies this requirement. The brightness of the TFEL panel is extremely dependent on the applied voltage in the lower voltage region, and tends to

* Thin film electroluminescent

saturate in the higher voltage region. Therefore, selected levels of intensity or shades of gray are readily obtained. In the same manner as the plasma display, resolution is a function of electrode spacing. Presently, only prototype units are available from the manufacturer with production units planned for calendar year 1979.

3.2.2 Multiformat Display Characteristics

At this juncture, it is appropriate to evaluate the characteristics of the concerned technologies and potential devices in terms of the requirements shown in Table III.

3.2.2.1 Active Area

One of the planned applications for the multiformat display will require the location of the display in the primary viewing cone of the operator. Because this space is prime, other essential displayed information must also reside within this area. Thus the active area of the display was sized namely to accommodate the worst case data density shown in Table III and also to permit maximum use of the remaining prime space in an effective manner.

3.2.2.2 Density Of Information

A standard page of text contains 2000 characters. The planned use of the multiformat display does not include such presentations as standard pages of text; but rather, the presentations include graphic depictions of ship's attitude and states as well as alphanumeric annotations and information listings. While the allocated active area could accommodate a standard page of text, such use as a so called "glass teletype" is not planned at this time.

3.2.2.3 Update Rate/Amount Of Changing Information

These categories were addressed jointly because of their inter-relationship. The values associated with these data categories were derived from considerations of the data depicting speed, depth and course rate of change. These parameters served to set the extreme or upper limit of these categories.

3.2.2.4 Total Number Of Formats

It was necessary in the allocation and sizing of memory to determine the number of different display formats. However, the assignment of this number does not preclude expansion of the read-only-memory of the display generator should the addition of formats be required.

3.2.2.5 Type Of Font

The specific type of font will be one of several possible candidates such as Mitre or Leroy. The mix of formats requires three sizes in both single and double line.

3.2.2.6 Type Of Graphics

The planned graphic depictions include straight line depictions to bound the tabular listing of status formats as well as representation of MIMIC displays of ship's attitude, plane and rudder angles as well as tank levels and other depictable status data. The extreme and eventual requirement will include full graphics capability including conics.

3.3 MECHANIZATION APPROACHES

The multiformat display is a self-contained unit that interfaces with the data transfer system via the parallel I/O controller. The display has an active area with a minimum diagonal of 9 inches. The display resolution is 512 x 512 lines. A dimming capability is provided to permit adjustment of the display brightness to a level satisfactory for low ambient light level viewing. In the case of the flat panel display, the necessary drive and address electronics for both serial and parallel dot address selection are provided. Also, a touch panel overlay is provided to accommodate operator selection of formatted display pages and control entries. The touch panel electronics and decoding logic are an integral part of the multi-format display. Electromechanical switching is provided for the power ON/OFF, Reset and Execute functions and are mounted in the front panel of the unit.

The CRT mechanization employs a flat face tube with the associated deflection and video amplifiers integral to the unit. Similar to the flat panel mechanization, a touch overlay is provided to accommodate operator selection of formatted display pages and control entries. The display is generated using the random position stroke writing technique.

Characters and symbols are generated in raster. The symbol/character font is stored in programmable read-only memory (PROM) and is readily changed.

3.3.1 Resolutions

The geometric area of the display screen should be resolved into 512 resolution elements in the X-axis and 512 resolution elements in the Y axis; this requirement applies to each of the three technologies.

3.3.2 Refresh Rate

The plasma display requires no refresh; the EL and CRT should be refreshed at a minimum rate of 30 frames per second to prevent any observable flicker.

3.3.3 Brightness

The display brightness should be variable and capable of permitting comfortable viewing in an ambient light level ranging from 0.1 to 25 foot-candles.

3.3.4 Contrast

The contrast ratio should be determined based on an 8:1 minimum when measured with 15 foot candles of ambient light vertically incident to a surface oriented orthogonally to the display face with a display output brightness of 20 foot lamberts.

3.3.5 Brightness Variations

The total effects of brightness variations including the display brightness, filters, EMI coating, and anti-reflective coating should not exceed + 20 percent of the nominal value over the display surface.

3.3.6 Jitter and Drift

The visually perceivable and measurable motion of any electronically generated image on the CRT display surface where no such motion should exist should not exceed $\pm 0.03\%$ of the CRT diameter (diagonally) over any period up to 1 second. The position of any electronically generated image point on the CRT display surface should not drift more than $\pm 0.1\%$ of the face plate diameter (diagonal) over any period up to 60 seconds in duration.

3.3.7 Deflection

Electron beam should be deflectable to any position on the CRT image area from any other position with beam settling to $\pm 0.1\%$ of the face plate diameter within 18 microseconds or less. Magnetic deflection and electrostatic focus should be features of the CRT assembly, as well as geometric focus correction. The advantages of electromagnetic deflection over electrostatic deflection are lower deflection power, use of lower voltages and freedom of deflection induced spot aberrations. The advantages of electrostatic focusing over electromagnetic focusing are simplicity of circuits, and reduced weight and alignment complexity associated with an electromagnetic focus yoke, with negligible degradation of performance. The dynamic focus correction circuit compensates for the CRT geometry to ensure uniform focus over the entire display surface.

3.4 INTERFACE

The *multiformat* display will interface with the C/D IU as shown. Interface is discussed in paragraph 2.4.3 with a block diagram in Figure 7. Although this particular interface has been selected for the Advanced Station Control application, any of the standard interface approaches, serial or parallel, can be mechanized where a particular application requires it.

3.5 MODULARIZATION

Several modular approaches are adaptable to the *multiformat* display. The above paragraphs discuss the display organization in terms of modules. It is possible to structure the unit modules on a separate basis with each an identifiable subassembly. Also, grouping of several modules on a common motherboard is possible. To this end, the primary determinants are the operational space and mounting requirements. Herein, height, width and depth dimensions should be considered. Each of the concerned technologies imposes unique physical and form factor constraints.

3.5.1 Cathode-Ray Tube

The cathode-ray tube requires a comparatively large depth dimension. The neck of the tube extends approximately 17 inches for a 9 inch diagonal face plate. Thus, the required depth of a CRT mechanized multiformat display will be approximately 20 inches. However, the width and height dimensions are comparatively small in comparison to flat panel displays. Ancillary controls or even the housing envelope can be located within one inch of the tube's face plate sides. Therefore, a CRT multiformat display should have a minimum envelope of 10"W x 10"H x 20"D. Further, this minimum sized envelope will house the deflection and video drive modules, as is a common practice. In a similar manner the display processor and generator module are contained in a separate housing, remote from the CRT assembly; this is also a common practice. However, if space permits, all modules can be integral to a single housing.

3.5.2 Flat Panel Displays

The flat panel displays offer significant benefits in terms of their minimum depth requirements. The plasma display panel is approximately one-half inch in thickness with the EL panel thickness less than one-half inch. The associated drive and address electronics require an additional 5 inches of depth. The address and drive electronics must be colocated with the flat panel display in order to reduce switching problems resulting from the large capacitive loads of the panel matrix cells. Therefore, a flat panel multiformat display should have a minimum depth dimension of 7 inches. The width and height dimensions of the flat panel displays are somewhat large in comparison to the CRT display. This is caused by the required spacing of electrode connections and cabling at the perimeter of the panel on all four sides. Approximately 2.5 inches on all four sides must be allowed, outside the active display area. Currently, the standard plasma display panel has a 12.09 inch diagonal with an 8.55

x 8.55 inch active area. The overall panel, including electrode connections for cabling measures 12.25 x 12.25 inches. It can be located within this width/height dimension. A 9 inch diagonal flat panel display will require a minimum envelope of 11"W x 11"H. Thus, the form factors for the flat panel multiformat display should be 11"W x 11"H x 7"D; this envelope excludes the display generator and interface electronics. The display generator/processor can be remotely located up to 6 feet away from the display assembly. Any front panel mounted controls and switches will increase the front panel dimensions by that dimension required for mounting the controls and switches outside of the panel allocated space. Similar to the CRT mechanization, all modules can be integral to a common envelope should mounting and operational space permit.

4.0 CONTROL/DISPLAY INTEGRATION

The identification of ship control system multifunction display requirements is a function of the information and control requirements of each ship control operator. Each operator's requirements, in turn, are dependent on the functions/subsystems/tasks assigned specifically to him. This function allocation stems from an analysis of the functions/subfunctions required to achieve ship control mission requirements.

Advanced Ship Control mission requirements were established for the AMSD Task 6 Design Assessment Plan. The following Functional Flow Diagrams describe the functions/subfunctions required to achieve those mission requirements. Subsequent sections detail the function allocations made for four-man, three-man and two-man crews and the information/action requirements identified for each operator position.

4.1 FUNCTIONAL FLOW DIAGRAMS

The following Functional Flow Diagrams are modifications of FFDs developed for the SSN 688 Ship Control Station design program. They differ from the SSN 688 FFDs primarily in the level of subfunction detail identified and in their relative freedom from mechanization assumptions.

Of the five top level functions which involve basic ship control requirements (see Task VI report, Part I), i.e.,: 1) Perform Sonar Search, 2) Perform Sonar Tracking, 3) Perform Sonar Localization, 4) Perform Open Ocean Transit, 5) Avoid Threat, the function Perform Open Ocean Transit was determined to require ship control functional capabilities which are inherent in all of the other four top level functions and which are representative of the mission segments selected for evaluating the ship control capability of each proposed design. Therefore, the top level function Perform Open Ocean Transit, was selected for detailed analysis and flow chart development.

Detailed FFDs for the Perform Open Ocean Transit top level function are provided in Appendix A. Each of the six major subfunctions identified as necessary for the performance of the top level function was further subdivided until sufficient detail was achieved to permit allocation to operator or equipment.

In detailing the subfunctions, many cases involved a subfunction previously called out for other subfunctions. To avoid a number of redundant entries, each having a different number designation, repeated subfunctions are shown with the symbol REF in the upper segment of the flow chart oval and with the subfunction number first used in designating it. Thus, the reader may return to that number designation elsewhere in the flow charts to determine whether any lower level functions have been identified for it. Any that are found are equally applicable to any functional sequence in which the original designation is referenced.

The FFDs provide the basis for assigning activities to the operator, the equipment, or a combination of both. However, it should be noted that the identification of the functions in the FFDs does not indicate whether they will be manual or automatic, thereby permitting alternate designs based upon various combinations. The following section defines the allocations made for three alternate SCS design utilizing, respectively, four-man, three-man and 2-man crews.

4.2 FUNCTIONAL ALLOCATION

Each of the lowest level functions identified in the FFDs of Appendix A must be assigned to some combination of crew or equipment to permit identification of operator tasks and, thereby, operator control/display requirements. The basis for this allocation is, in part, a function of crew size, automation feasibility/cost and ship safety.

Separate allocations were made for four-man, three-man and two-man crews. The Function Allocation tables for the three crews are presented in Appendices B, C, and D, respectively. The four-man crew station was modeled after the SSN-688 SCS and consisted of a Diving Officer, Stern Plane Operator, Fairwater Plane/Helmsman, and Ballast Control Panel Operator, who serves as Chief of the Watch. Most functions are manually performed during normal operations, with some backup automation if desired.

The three-man crew allocation utilized a Diving Officer, a Ship Control Operator, and a Ballast Control Operator. The BCO fills the role of COW. The allocation assumed that automatic functions would be used for normal operating modes, with manual backup available. It was also assumed that the three-man design would utilize advanced integrated controls and displays to facilitate monitoring by exception and for achieving greater precision in ship control.

The two-man crew allocation assumed a high degree of automation, utilizing a Ship Control Officer, and a Ballast Control Operator. The SCO combines the skills of the DO and SCO of the three-man crew while the Ballast Control Operator is also Chief of the Watch.

Functions in the tables which were allocated for the initial callout were not repeated for later sequences. Thus, the function numbers may not run sequentially for all subfunction sets.

4.3 INFORMATION/ACTION ANALYSIS

The Function Allocation tables in Appendices B, C, and D define the totality of operator tasks for the three crew stations. The determination of suitable controls and displays for operator task performance is derived from an analysis of the information required by the operator to monitor performance and decide on the need for action and of the actions required as a result of the decisions. Results of this analysis are contained in Appendix E, Information Requirements Analysis and Appendix F, Action Requirements Analysis.

Information requirements are described in terms of characteristics important to the determination of control/display mechanization requirements, such as temporal form, rapidity of availability, operator sampling rate, criticality and measurement units, where applicable. Action requirements are described in similar terms.

4.4 SUMMARY AND RECOMMENDATIONS

The foregoing analyses are intended to provide the basis for evaluating multiformat display technologies to be used as primary control and display devices in the Advanced Control Station. The analyses were performed separately for a four-man, a three-man, and a two-man crew station. Assumptions were made concerning the level of automation, the assignment of tasks to each crew member, and the philosophy of control/display integration for each crew station alternative.

The results of these preliminary analyses indicate that for a four-man crew, such as exists today on all nuclear attack submarines, the need (or requirement) for a multiformat display cannot be demonstrated on the basis of operator workload*. The basic reason for this is that present attack submarines (except for the SSN 688 class) operate in a depth-speed reaction-time envelope such that a four-man crew represents an under-utilization of personnel and hence the workload reduction offered by a multiformat display is not justified. In the case of the SSN 688 class, the Navy is introducing the Aided Display Submarine Control System, ADSCS (AN/BYQ-1), which

* Previous ASCOP studies have addressed this need on the basis of safety.

will accommodate all control requirements for that class. However, for three-man and two-man crews, the situation is quite different. The analyses presented in the appendices indicate that for a three-man crew, the BCO experiences periods of saturation without a multiformat display and for a two-man crew, both the SCO and the BCO experience significant periods of total saturation without a multiformat display. Because the ASCOP ACS will result in either a three-man or two-man crew, the recommendation of this study is that a multiformat display(s) is a requirement for the ASCOP ACS.

Based on information and control requirements for each operator in each configuration, maximum parametric requirements imposed on the multiformat display were identified. The three leading candidate display technologies (CRT, plasma, and electroluminescence) were assessed to determine the mechanization necessary to adapt them to meet the maximum parametric requirements identified by the analysis. A set of specifications for each technology candidate was provided for the more critical parameters.

Each of the candidate display technologies was judged suitable for use as a multiformat display; however, selection of the device or devices for the ACS must be made in the context of the total crew station design. A high percentage of the information and control requirements for both the three-man and two-man crew stations was judged to be suitable for integration into the multiformat display concept. Total acceptance of this judgement would result in a very large reduction in dedicated controls and displays found on present ship control stations. However, actual design of display/control formats for the multiformat display must consider a number of additional factors, such as the feasibility and cost of remote computer control of functions currently controlled directly by manually operated switches.

It is recommended that the development of multifformat and control/display integration concepts for ACS should next involve the design of display formats and control hierarchies, taking into account the impact on remote functions, and the design of the computer architecture necessary to permit interactive control/display integration. Concurrent with these tasks, it is recommended that current three-man and two-man baseline console designs be updated to include the results of these analyses and to reflect the impact of the major reduction of instrumentation implied by the information/action analyses.

C78-1091/301

APPENDIX A

FUNCTIONAL FLOW DIAGRAMS FOR THE TOP LEVEL
FUNCTION "PERFORM OPEN OCEAN TRANSIT"

C78-1091/301

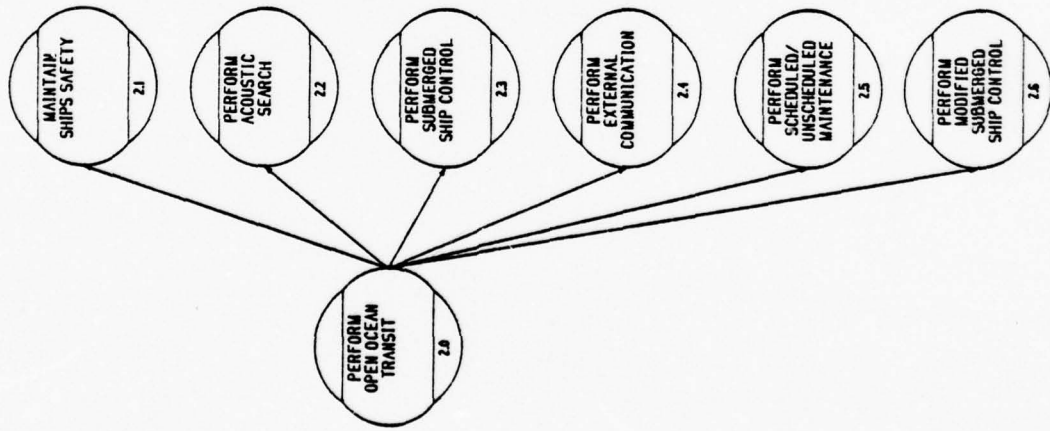

I. FUNCTIONAL FLOW DIAGRAM:
SHIP CONTROL-RELATED FUNCTIONS

C78-1091/301

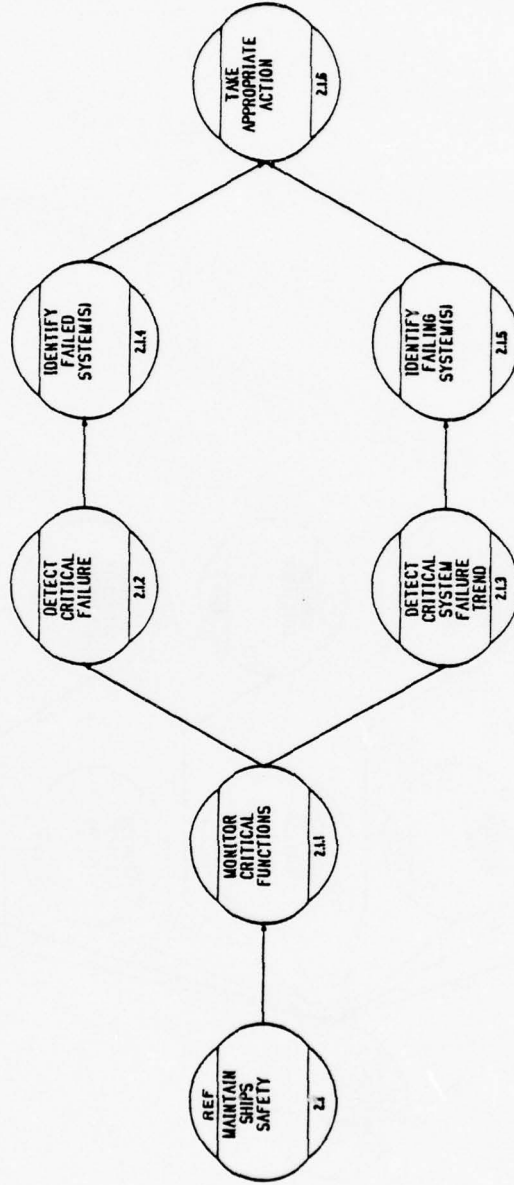

C78-1091/301

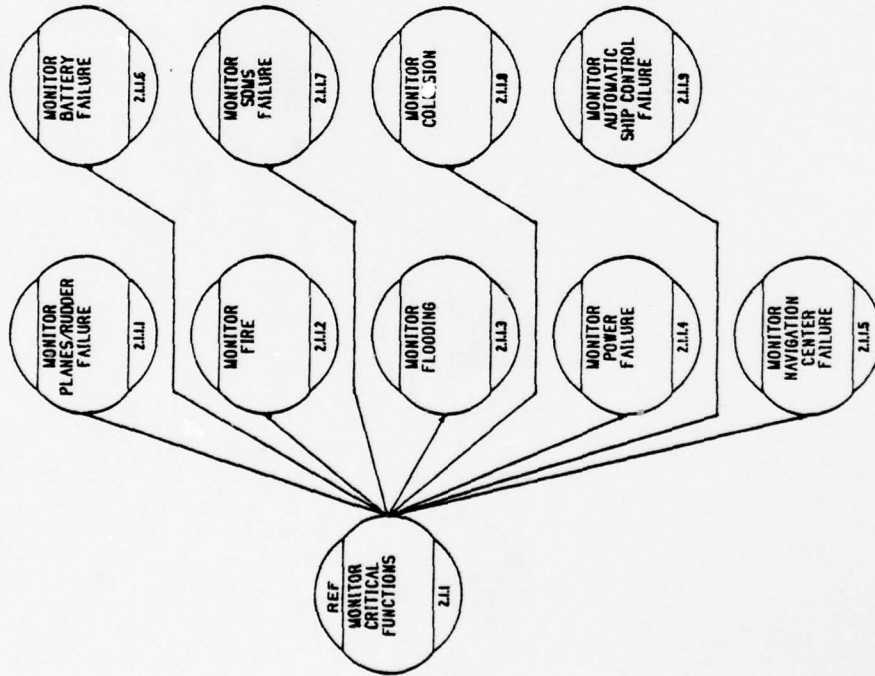

C78-1091/301

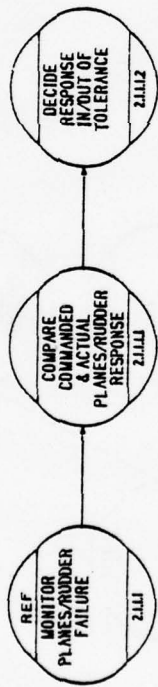

C78-1091/301

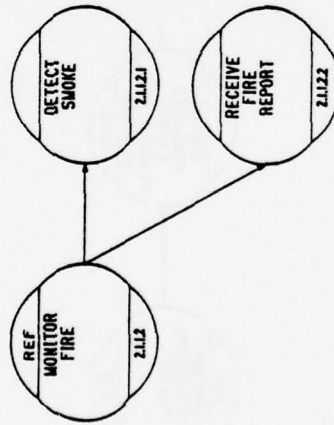

C/8-1091/301

A-7

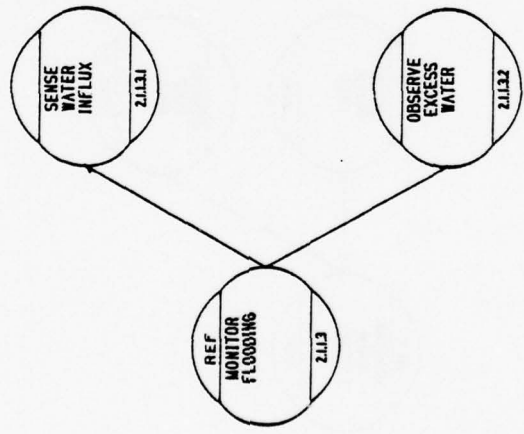

C78-1091/301

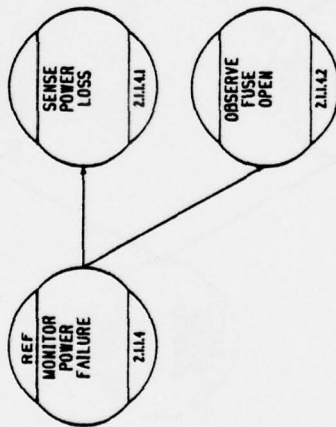

C78-1091/301

A-9

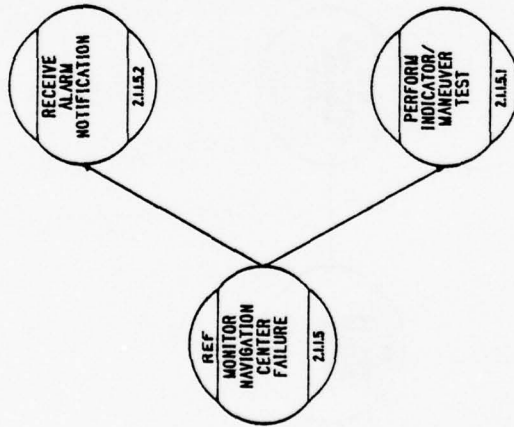

C78-1091/301

A-10

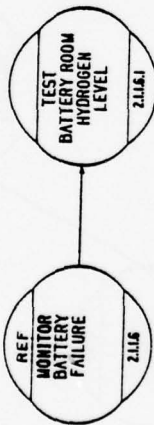

C78-1091/301

A-11

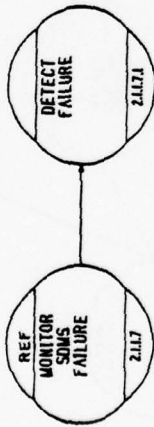

C78-1091/301

A-12

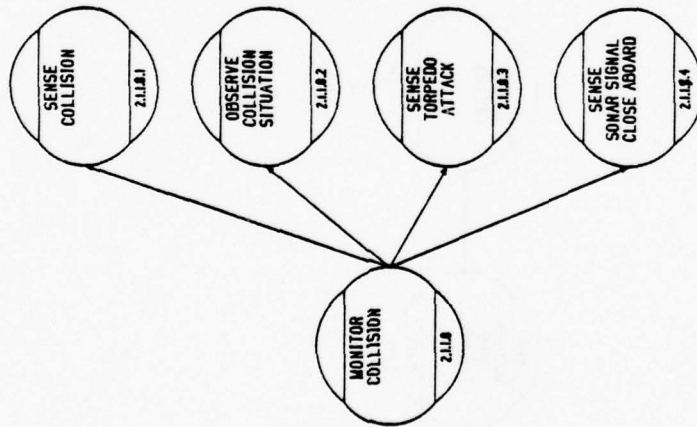

C78-1091/301

A-13

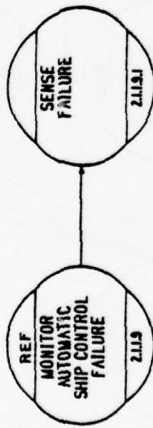

C78-1091/301

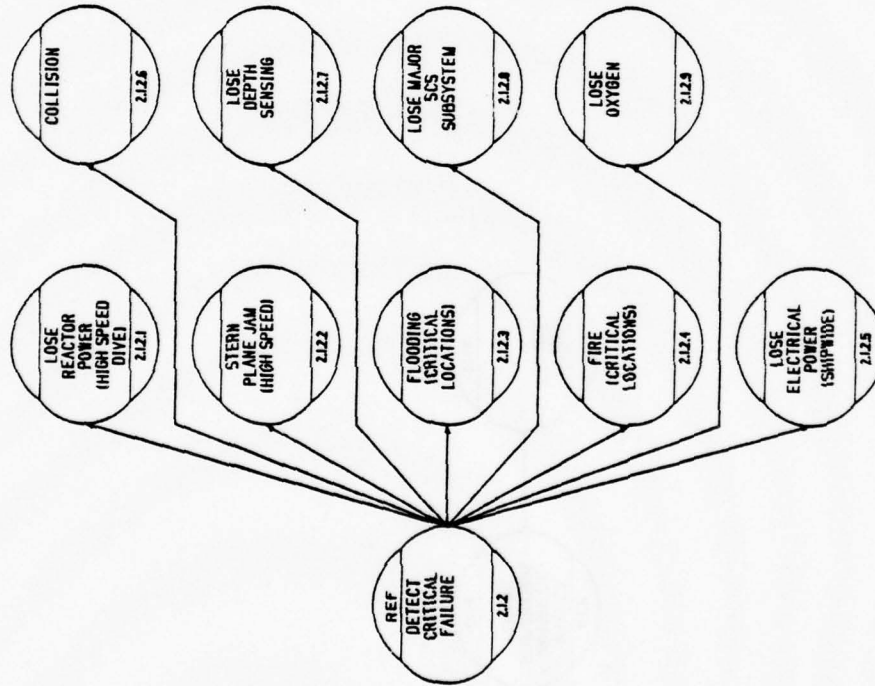

C78-1091/301

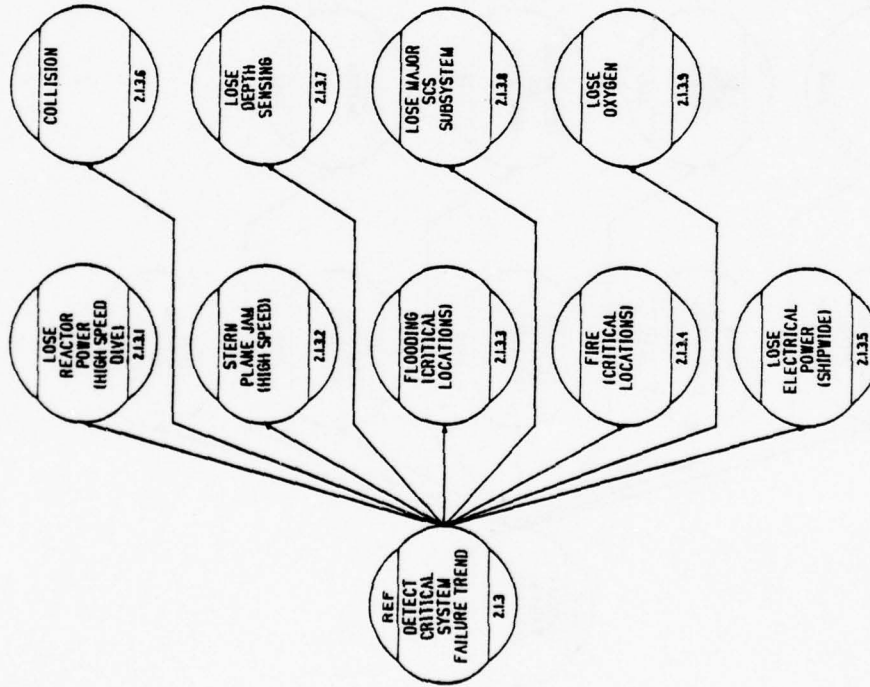

C78-1091/301

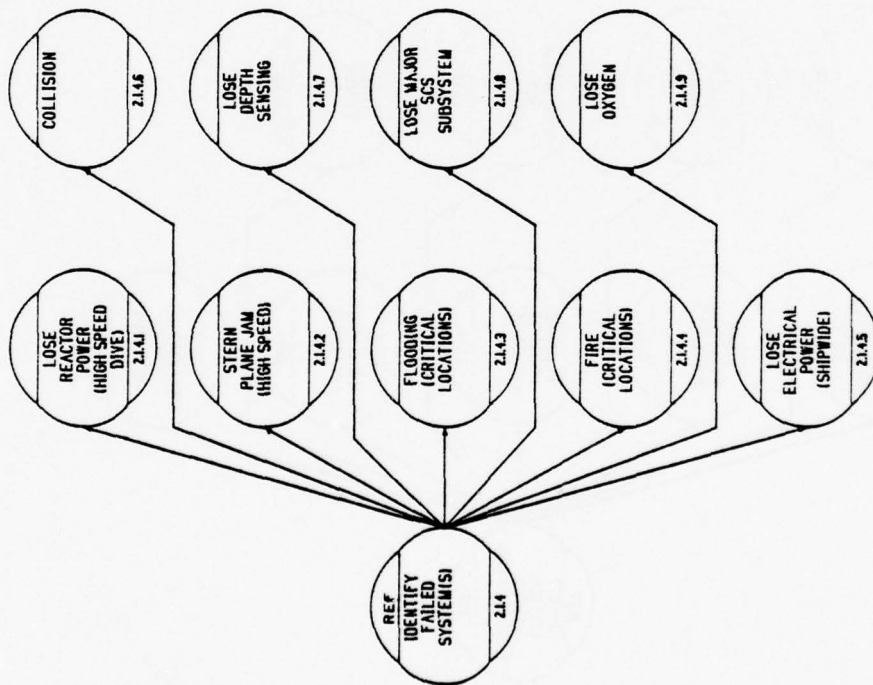

C78-1091/301

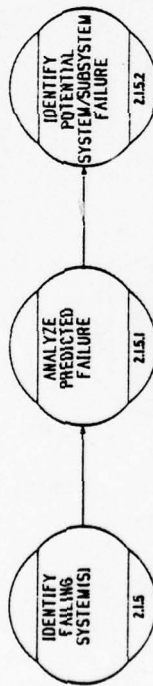

C78-1091/301



C78-1091/301

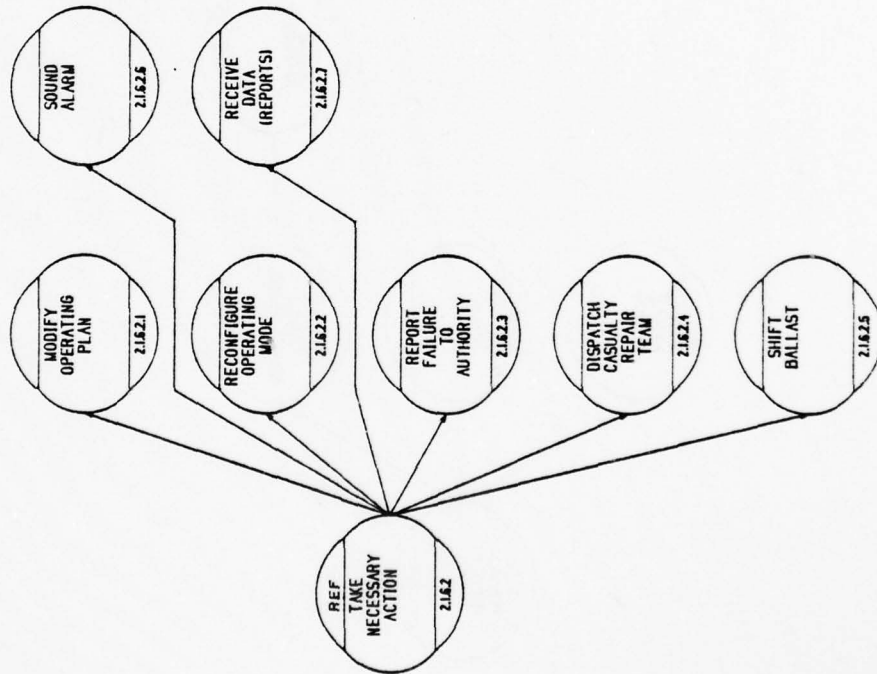

C78-1091/301

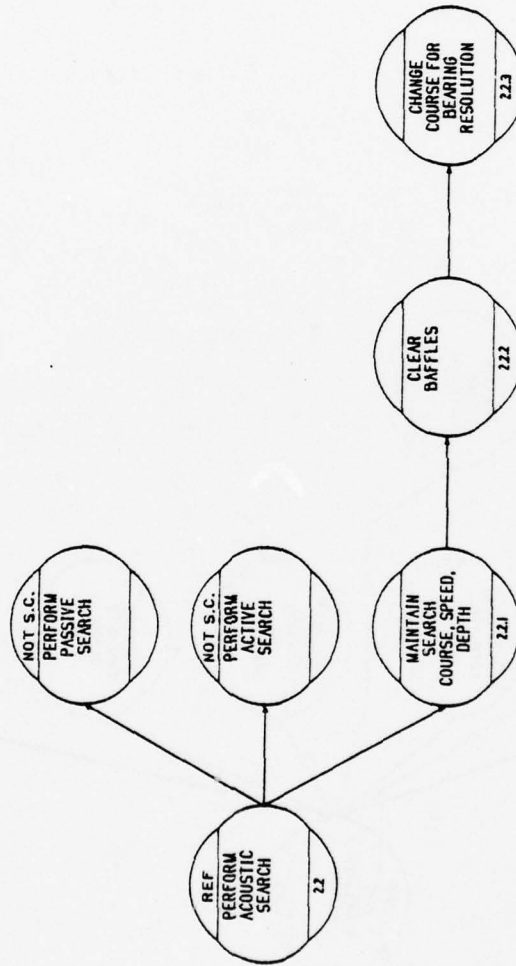

C78-1091/301

A-21

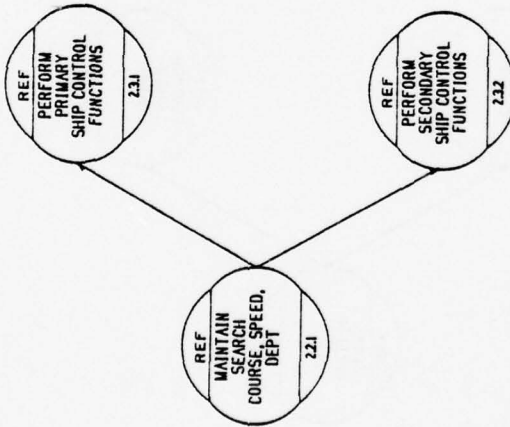

C78-1091/301

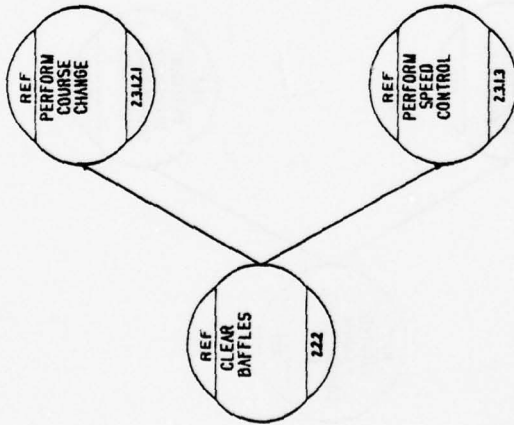

A-22

C78-1091/301

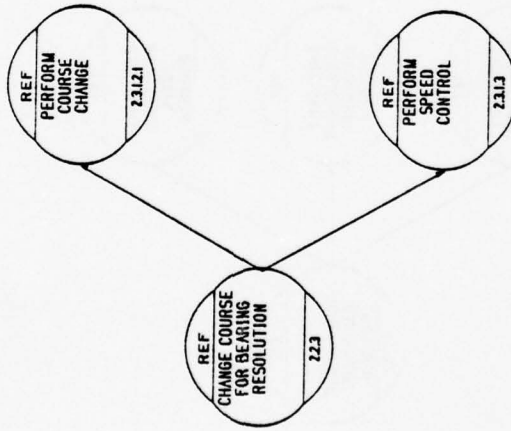

C78-1091/301

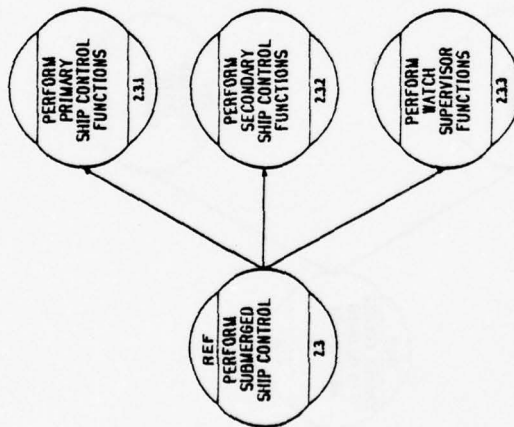

C78-1091/301

A-25

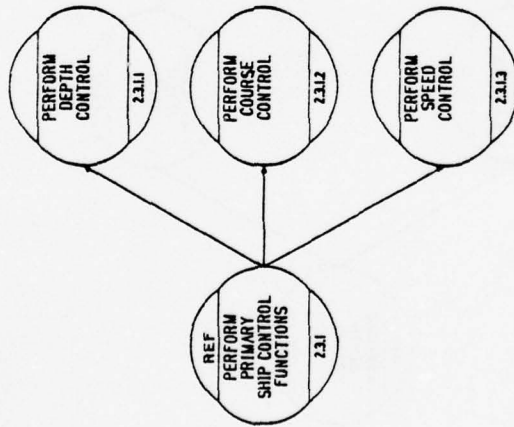

C78-1091/301

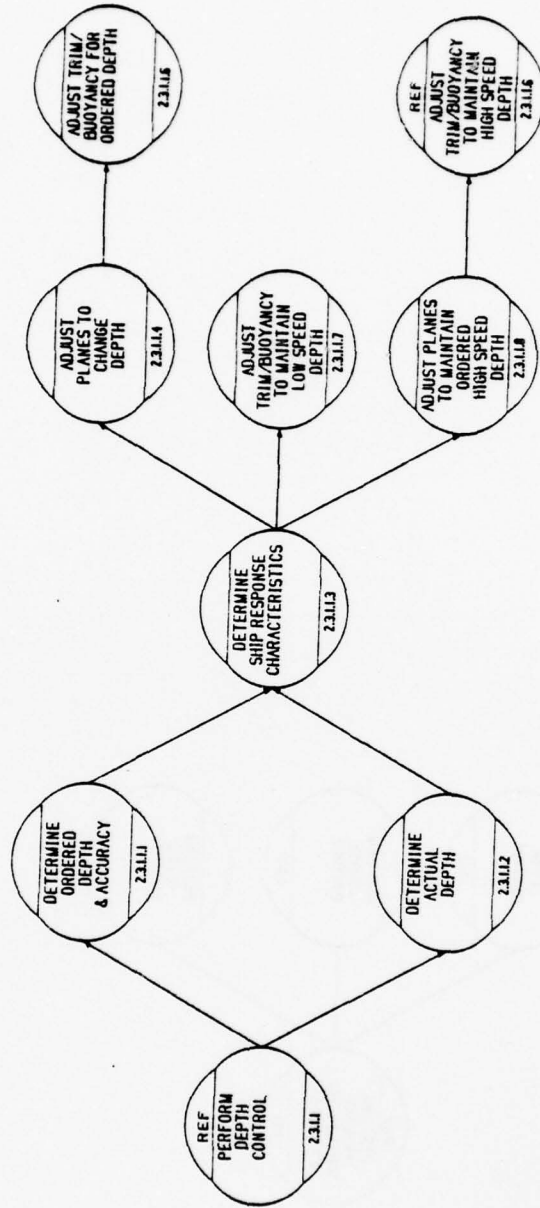

C78-1091/301



C78-1091/301

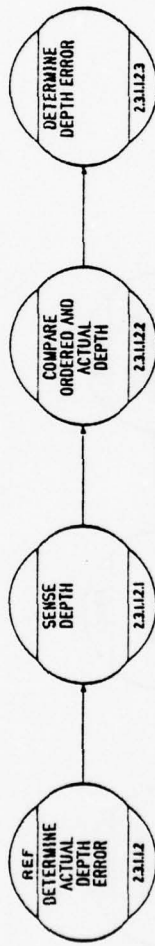

C78-1091/301



C78-1091/301

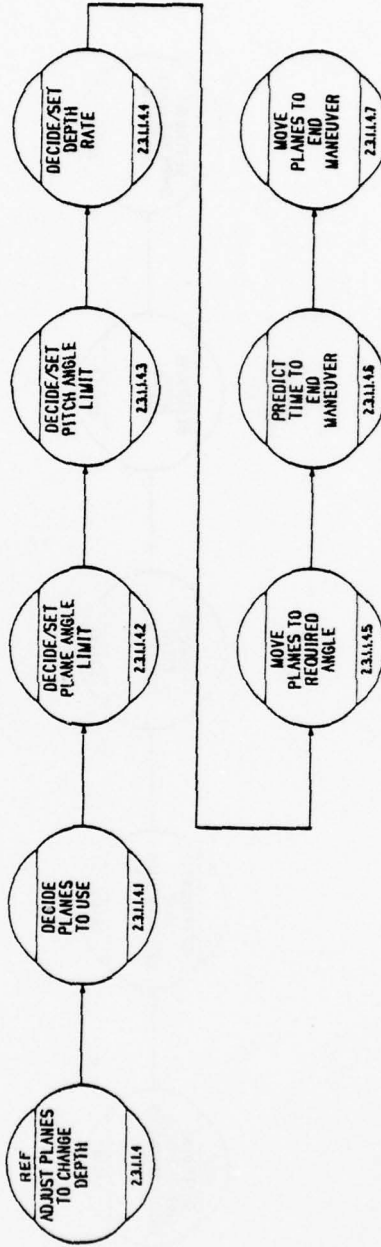

C78-1091/301

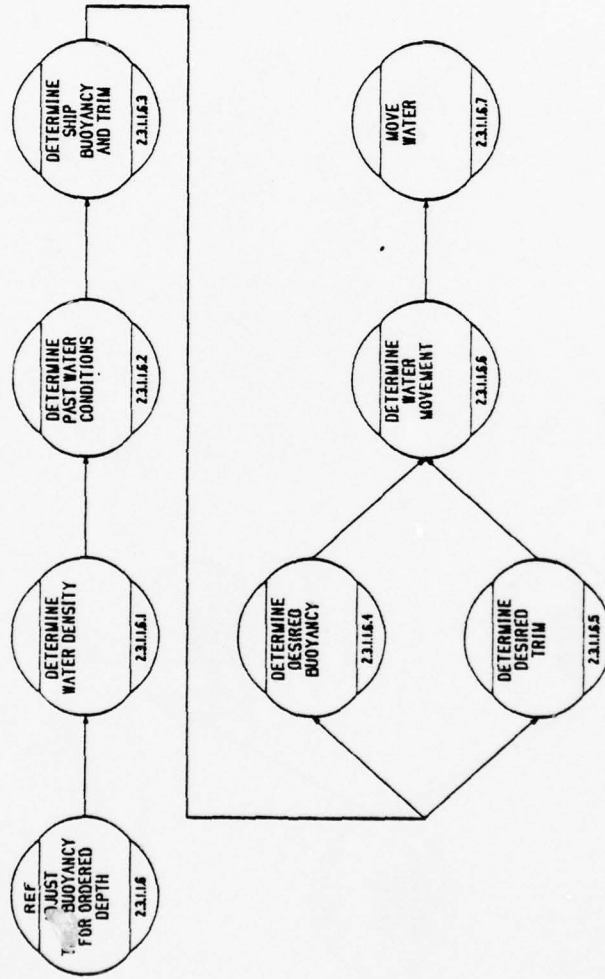

C78-1091/301

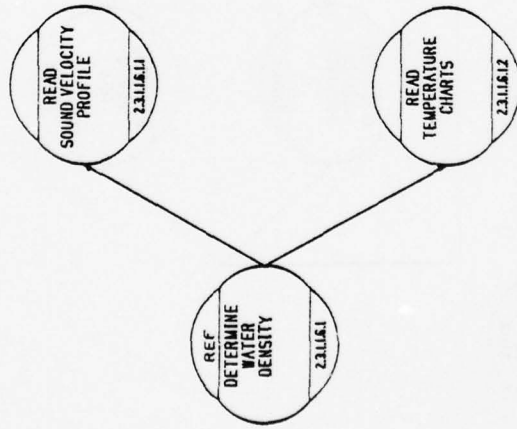

AD-A062 740

ROCKWELL INTERNATIONAL ANAHEIM CA AUTONETICS MARINE --ETC F/G 17/2
ADVANCED SUBMARINE CONTROL PROGRAM.(U)
OCT 78

N00024-78-C-5308

UNCLASSIFIED

C78-1091/301

NL

2 OF 4

AD
A0 82740



The grid contains 132 small images arranged in 11 rows and 12 columns. The top two rows contain sparse patterns of characters, including '0', '1', '2', '3', '4', '5', '6', '7', '8', '9', 'A', 'B', 'C', 'D', 'E', 'F', 'G', 'H', 'I', 'J', 'K', 'L', 'M', 'N', 'O', 'P', 'Q', 'R', 'S', 'T', 'U', 'V', 'W', 'X', 'Y', 'Z'. The bottom nine rows contain dense, repetitive patterns of characters, possibly representing a data stream or a specific code sequence. The characters are arranged in a grid-like fashion, with some rows showing a clear vertical alignment of characters.

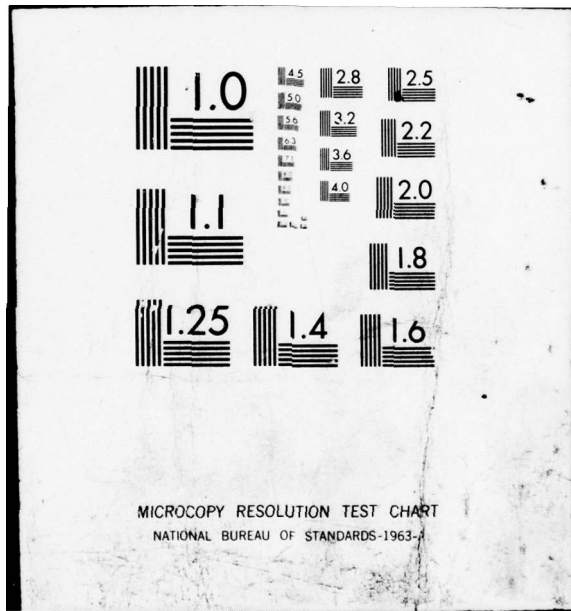

MICROCOPY RESOLUTION TEST CHART
NATIONAL BUREAU OF STANDARDS-1963-A

C78-1091/301

A-33

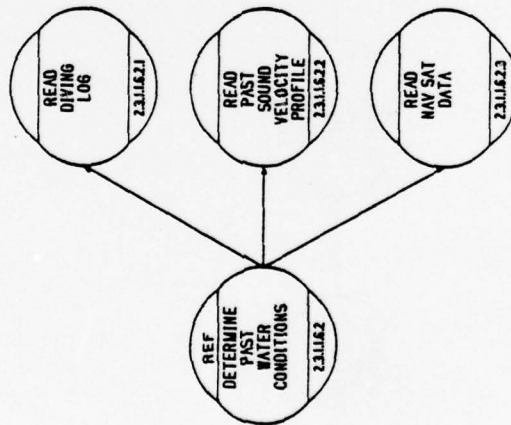

C78-1091/301



C78-1091/301

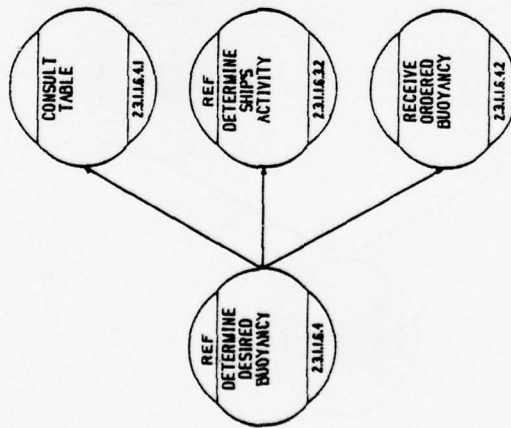

C78-1091/301

A-36

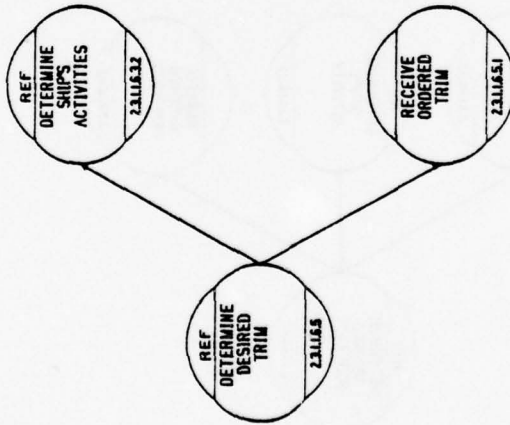

C78-1091/301

A-37

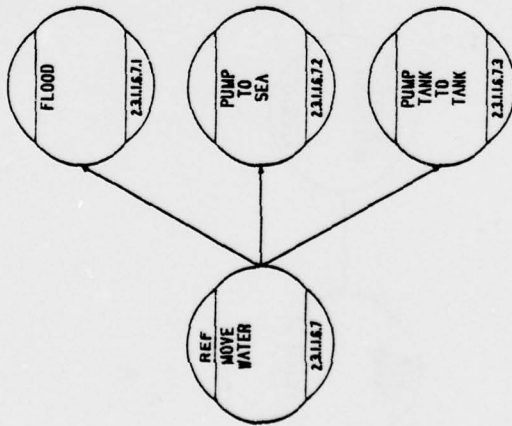

C78-1091/301



C78-1091/301

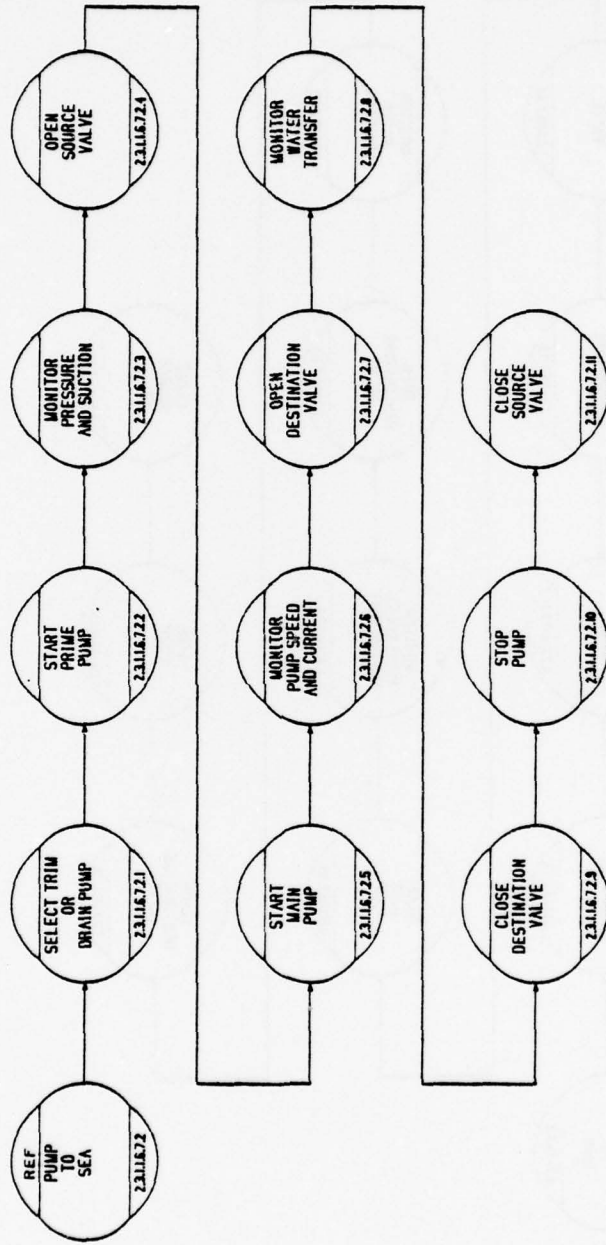

C78-1091/301

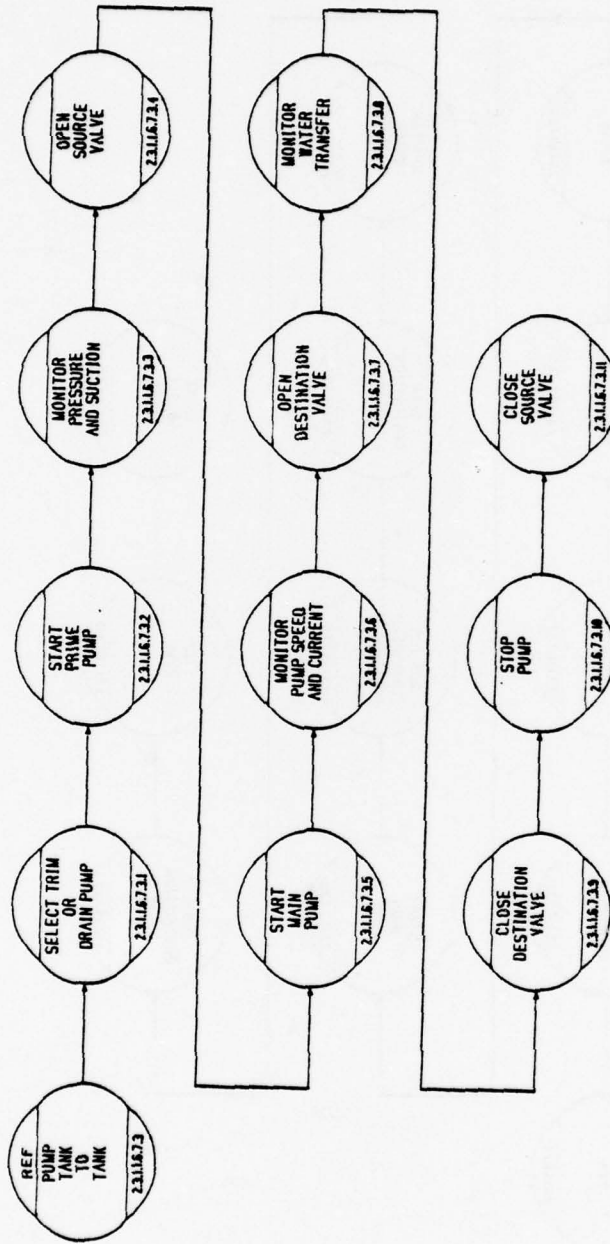

C78-1091/301

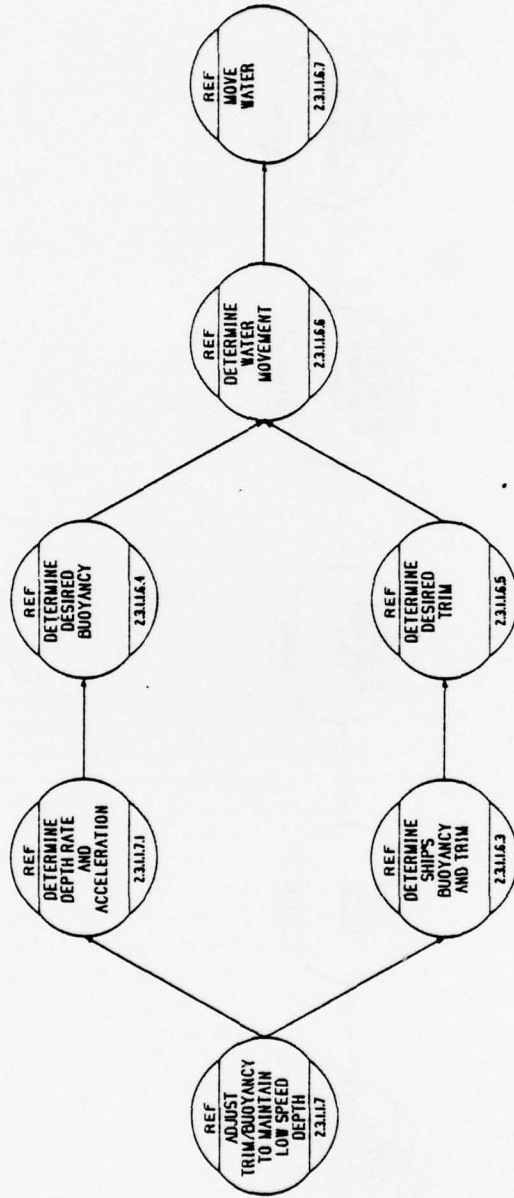

C78-1091/301

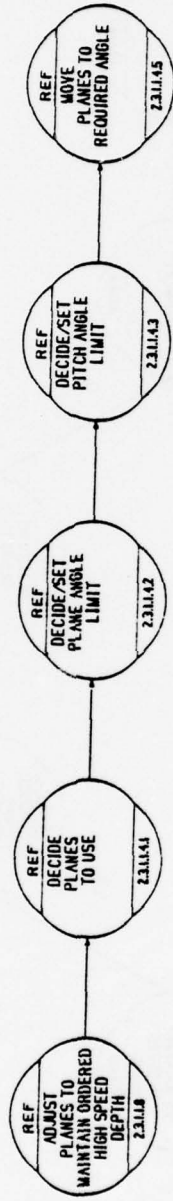

C78-1091/301

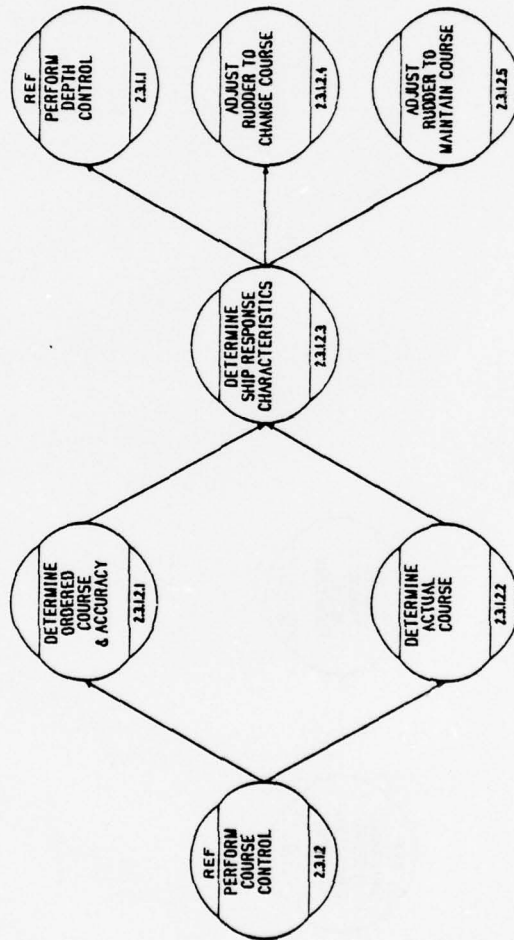

C78-1091/301

A-44

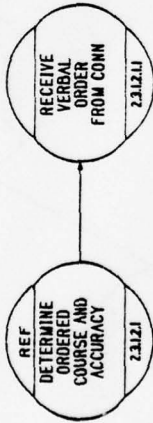

C78-1091/301

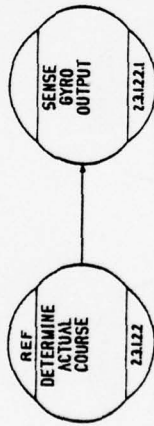

C78-1091/301

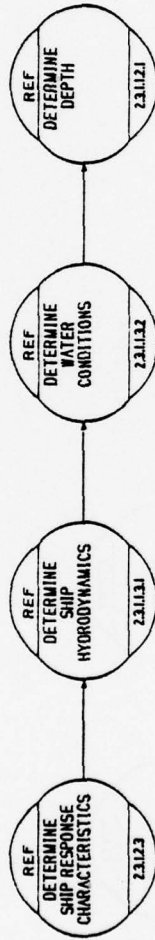

C78-1091/301

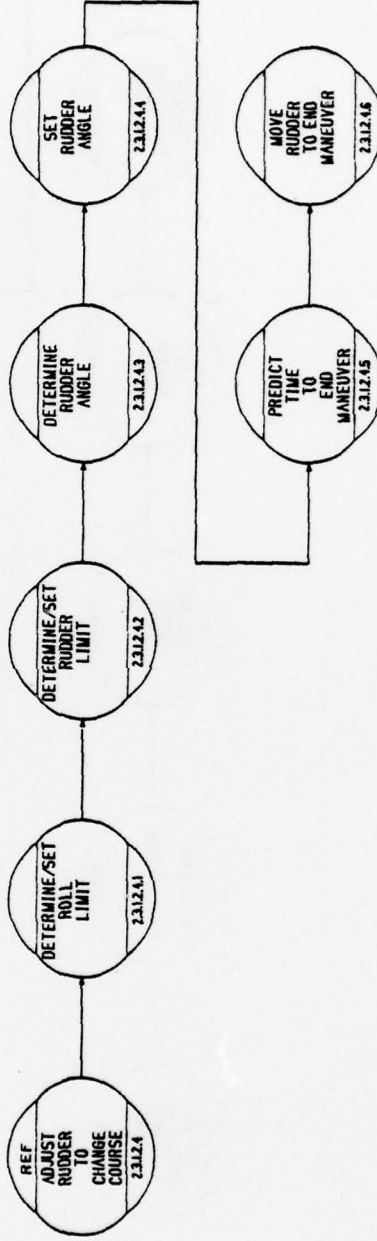

C78-1091/301

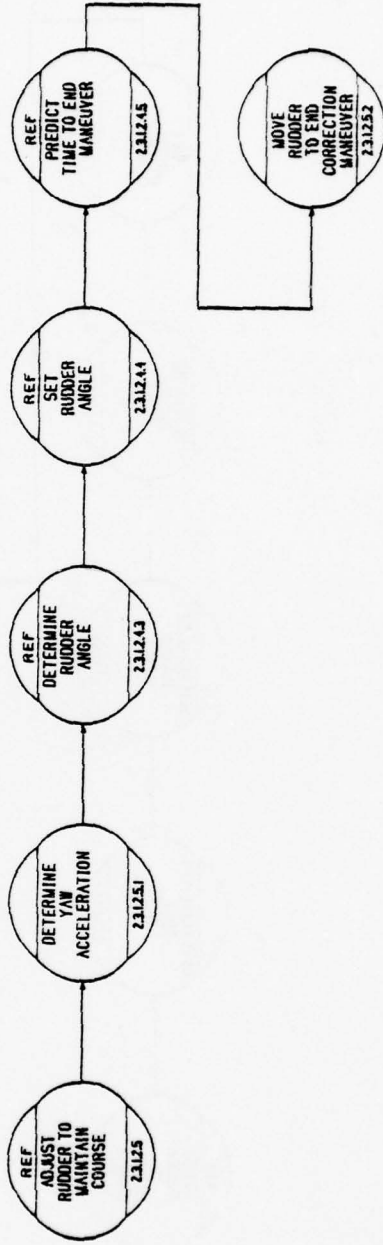

C78-1091/301

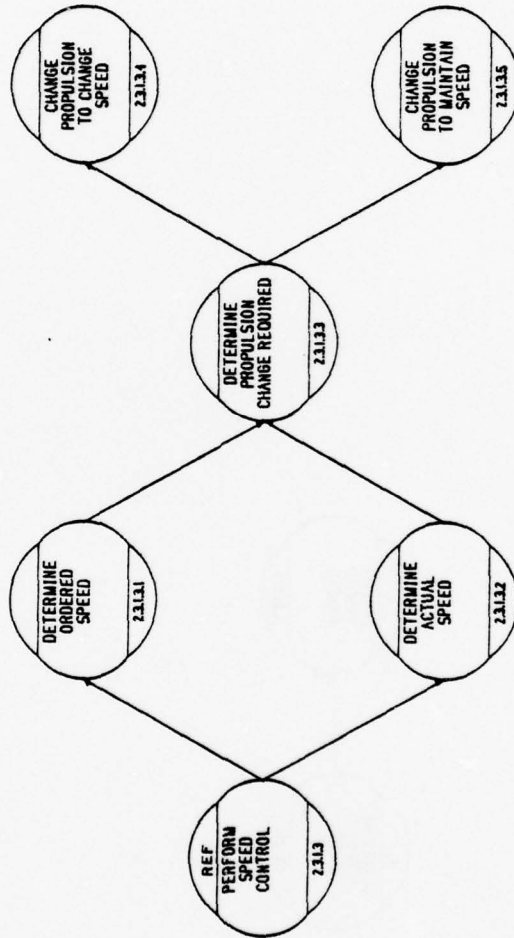

C78-1091/301

A-50

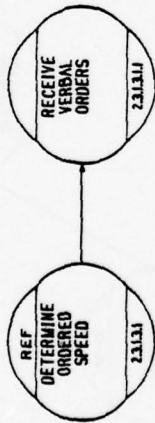

C78-1091/301

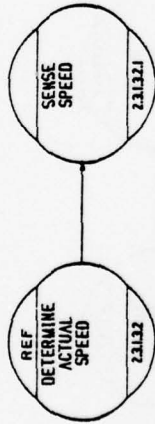

C78-1091/301

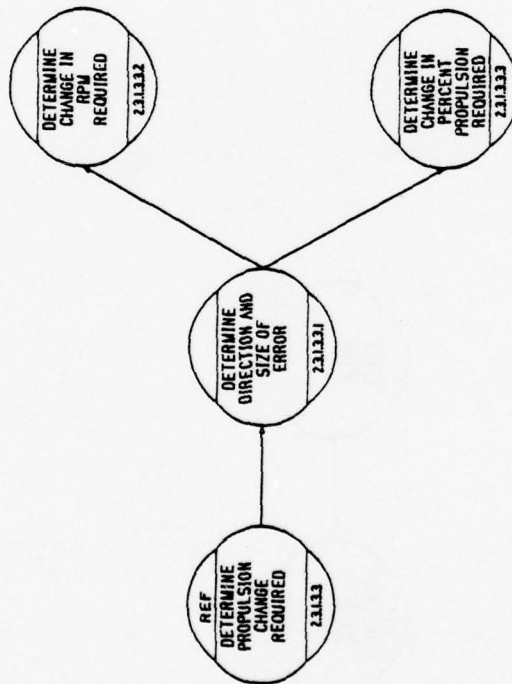

C78-1091/301

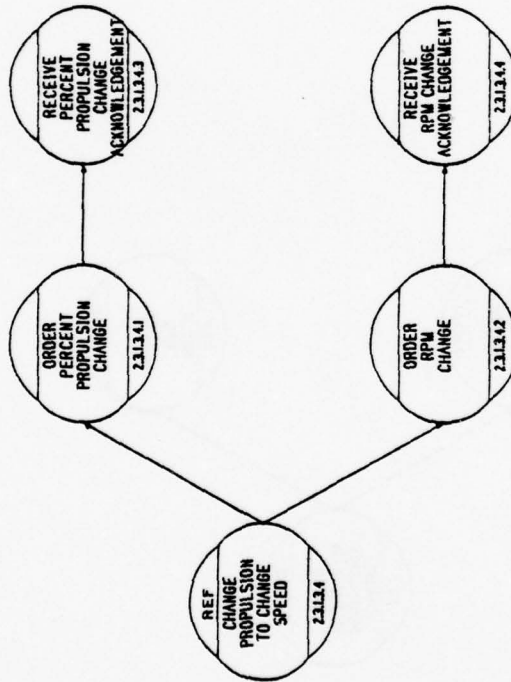

C78-1091/301

A-54

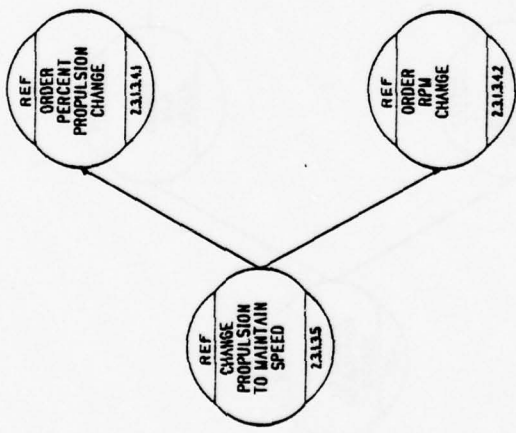

C78-1091/301

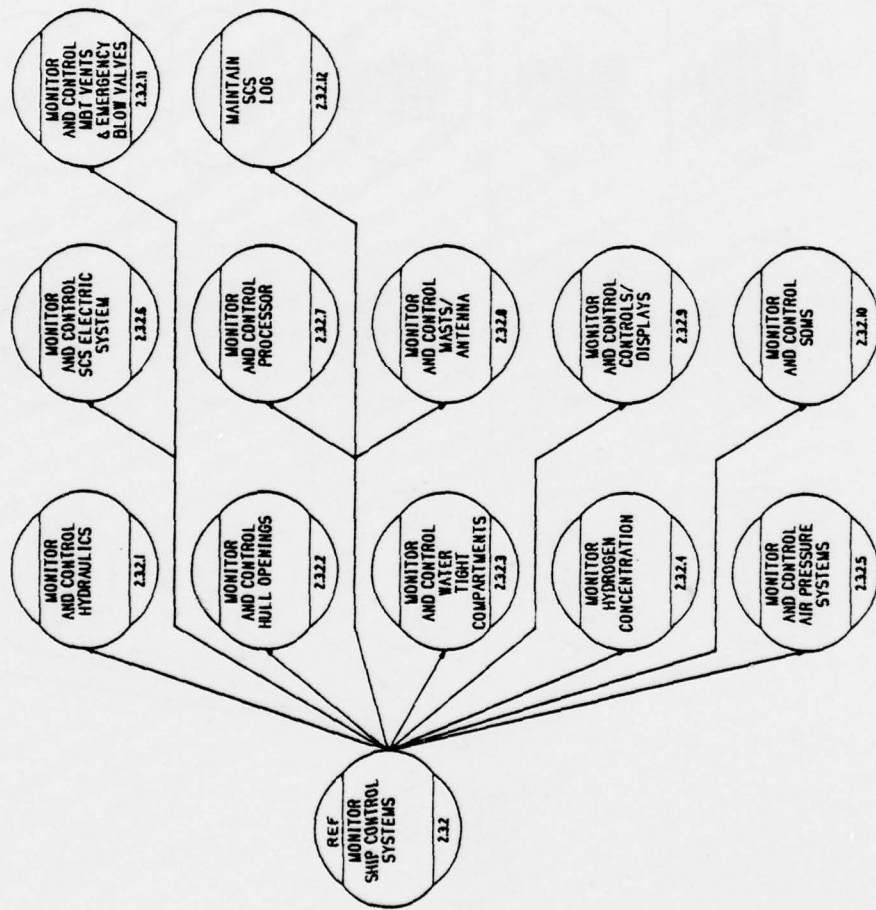

C78-1091/301

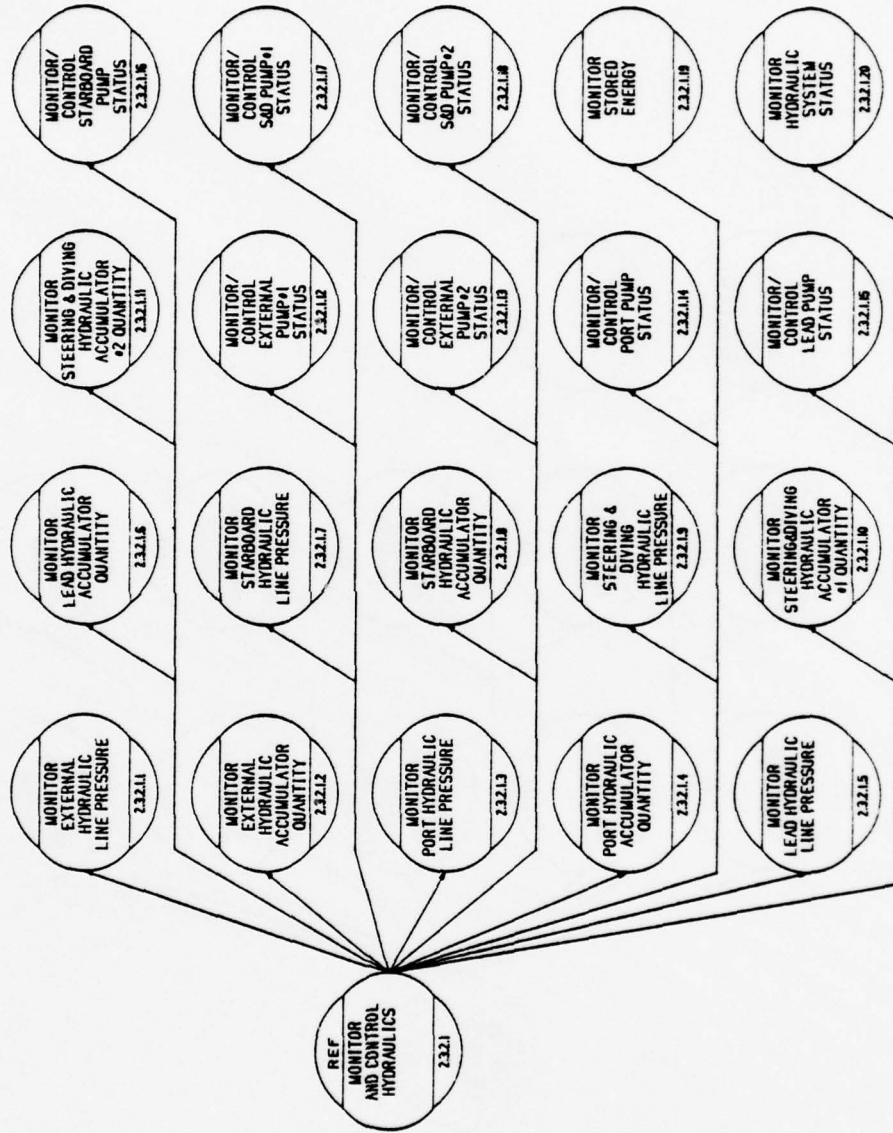

C78-1091/301

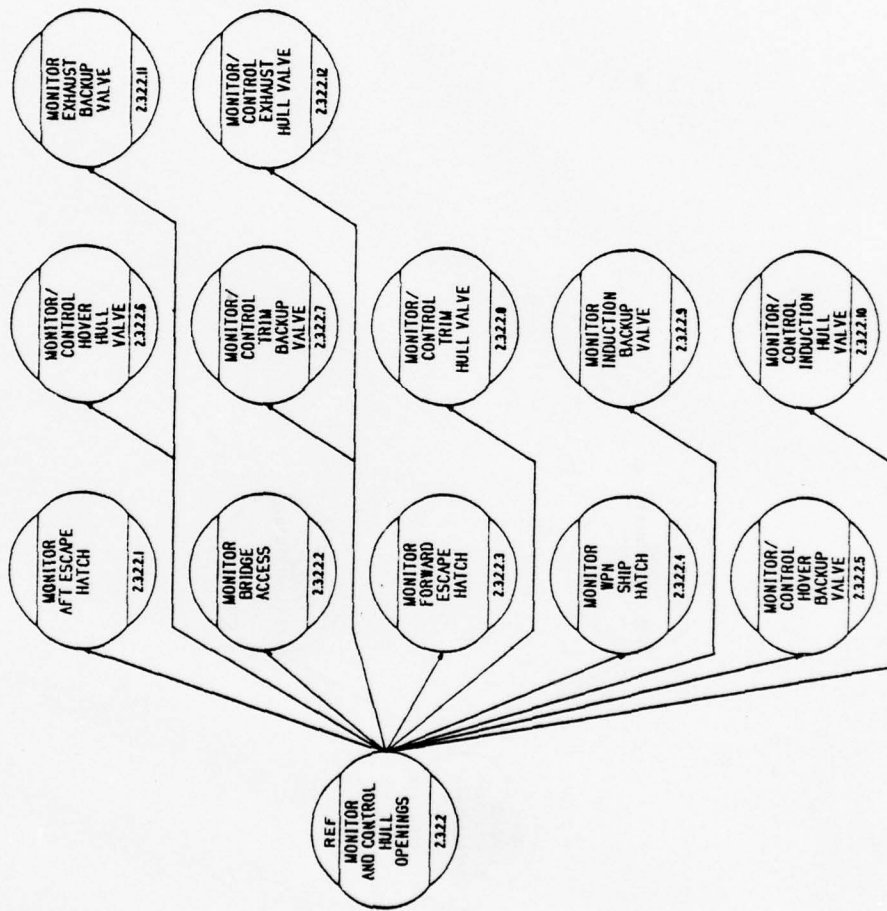

C78-1091/301

A-58

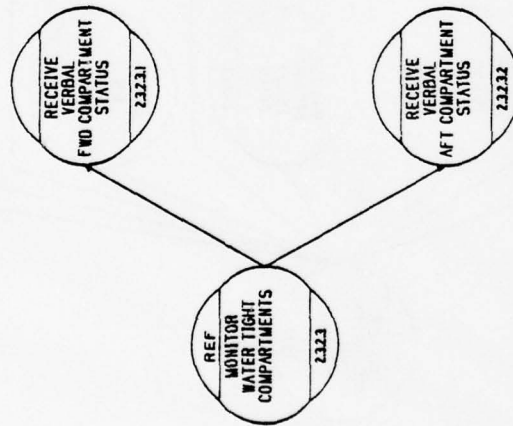

C78-1091/301

A-59

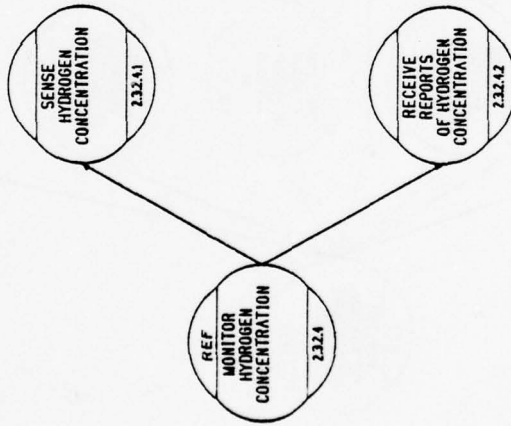

C78-1091/301

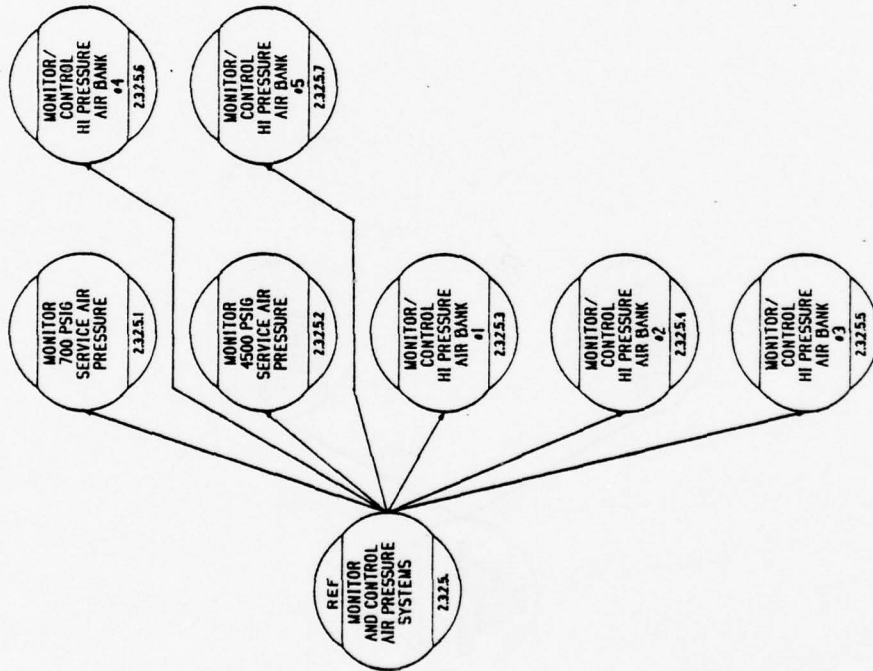

C78-1091/301

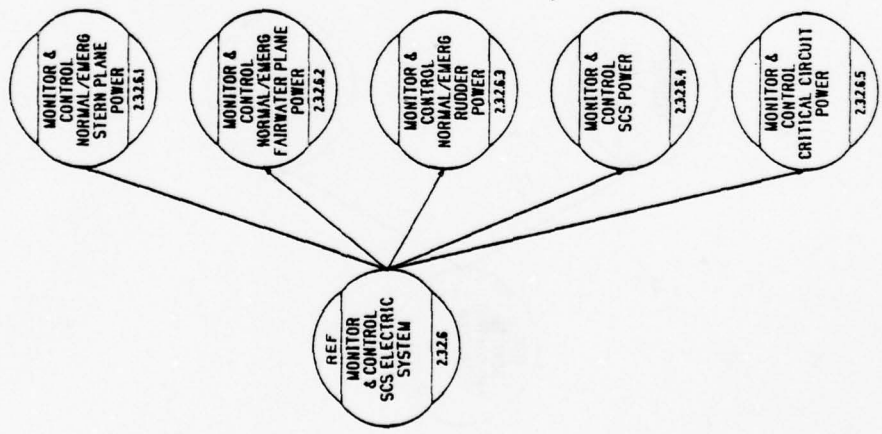

C78-1091/301

A-62

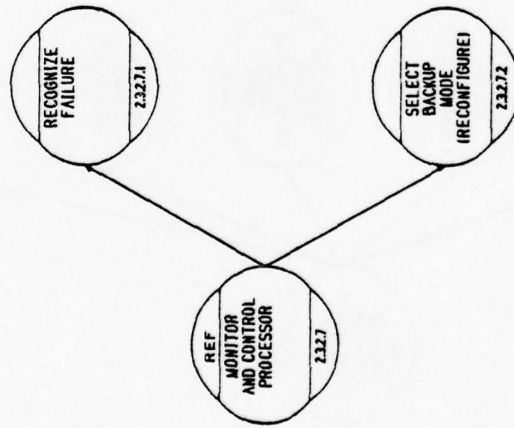

C78-1091/301

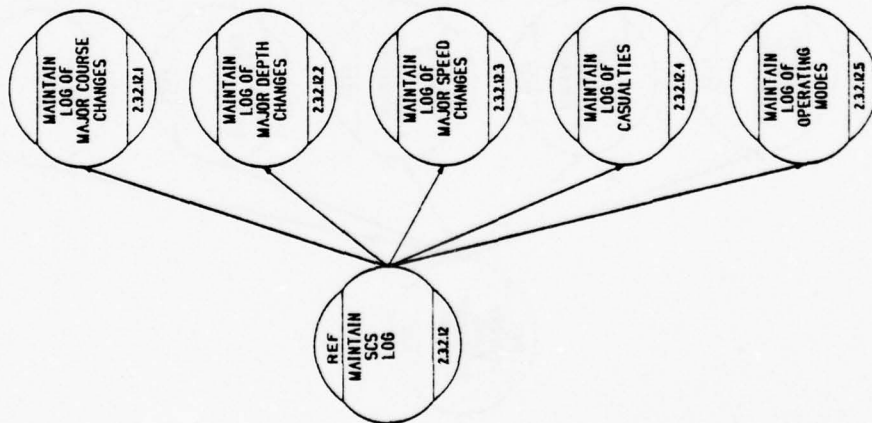

C78-1091/301

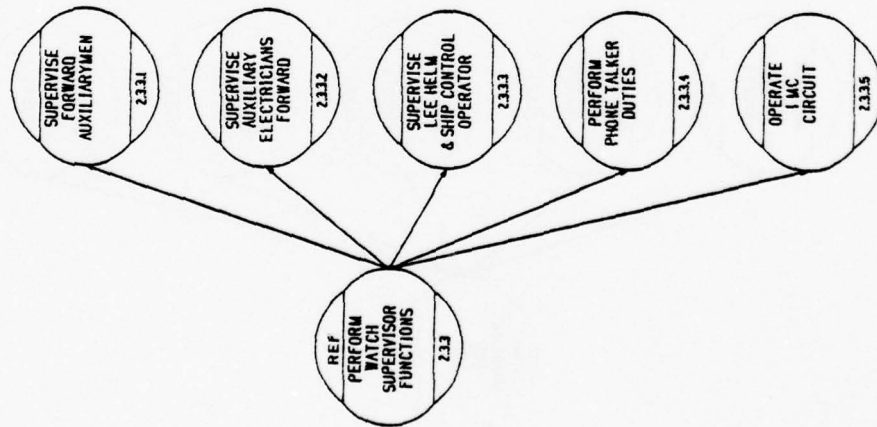

C78-1091/301

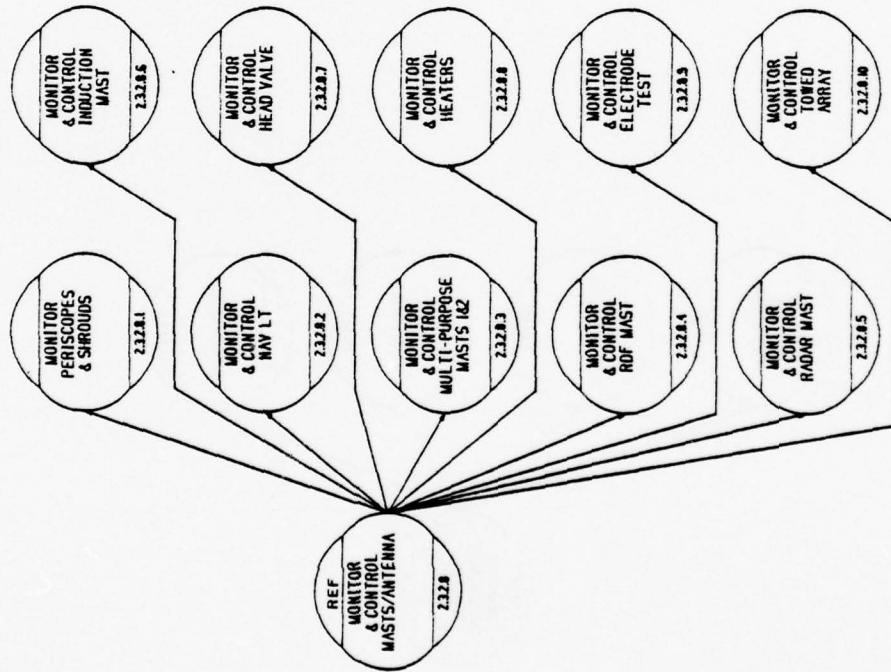

C78-1091/301

A-66

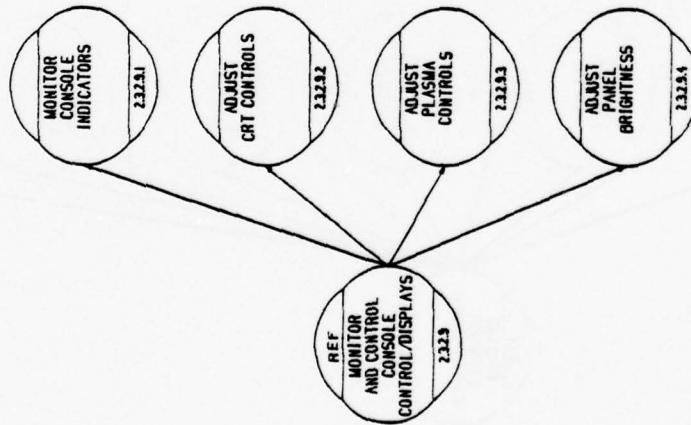

C78-1091/301

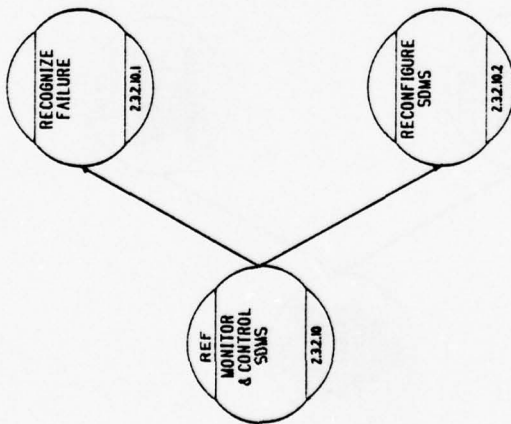

A-67

C78-1091/301

A-68

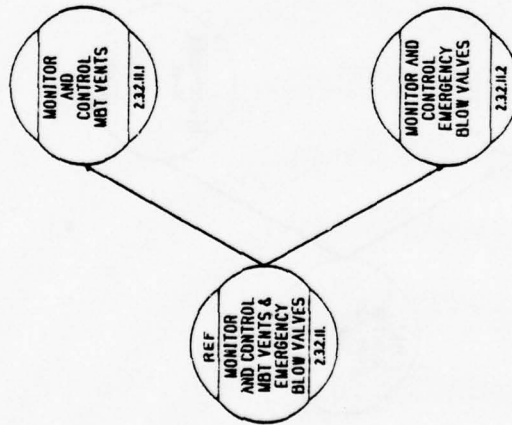

C78-1091/301

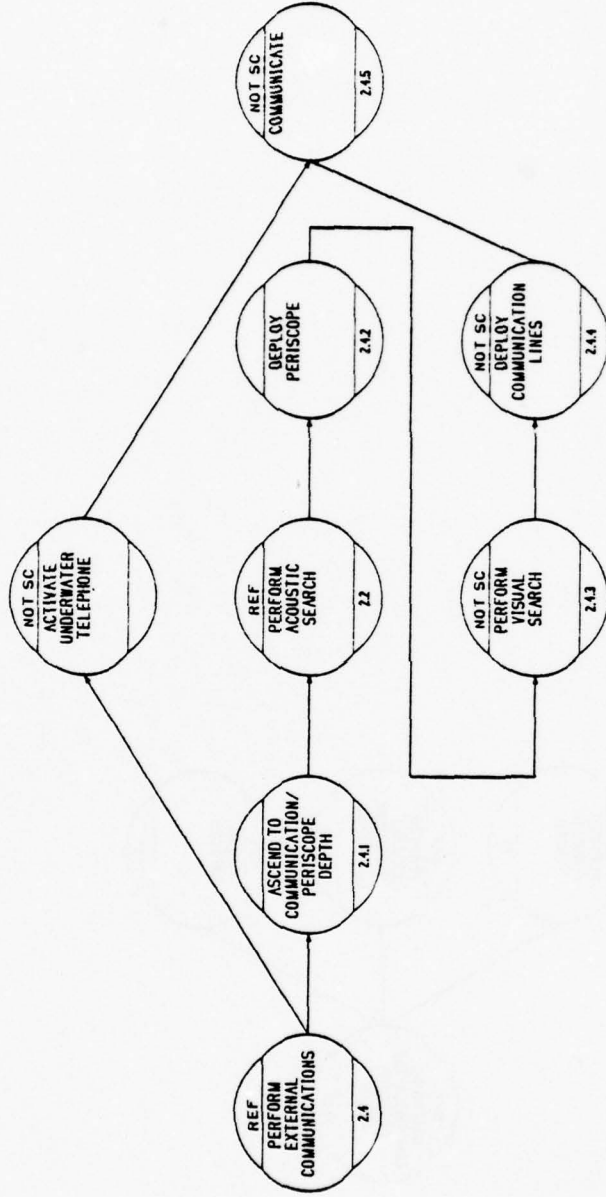

C78-1091/301

A-70

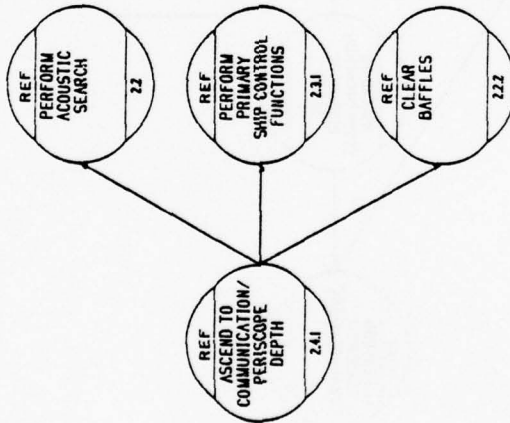

C78-1091/301

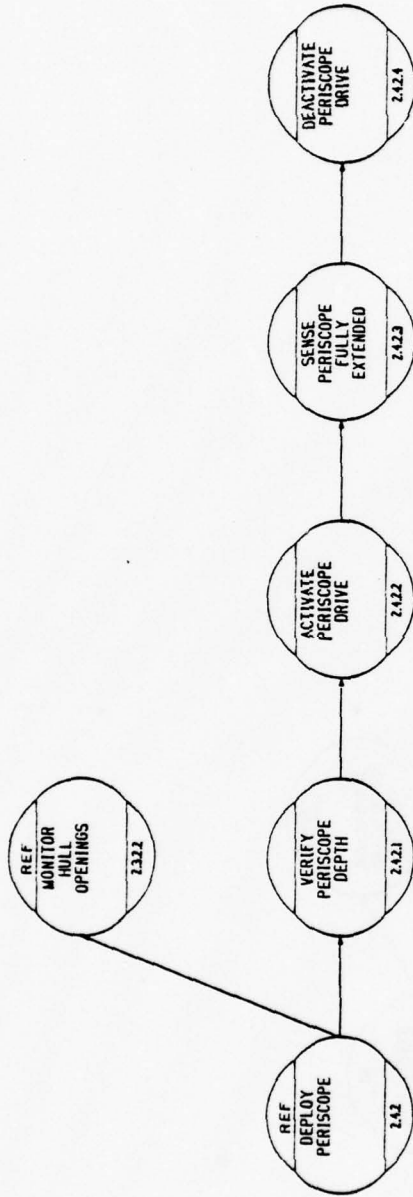

C78-1091/301

A-72

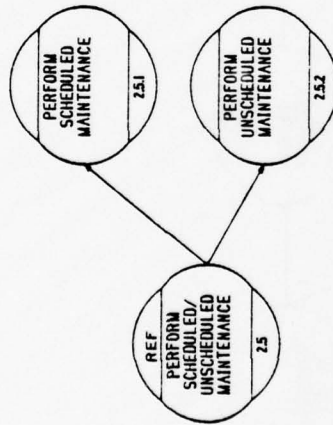

C78-1091/301

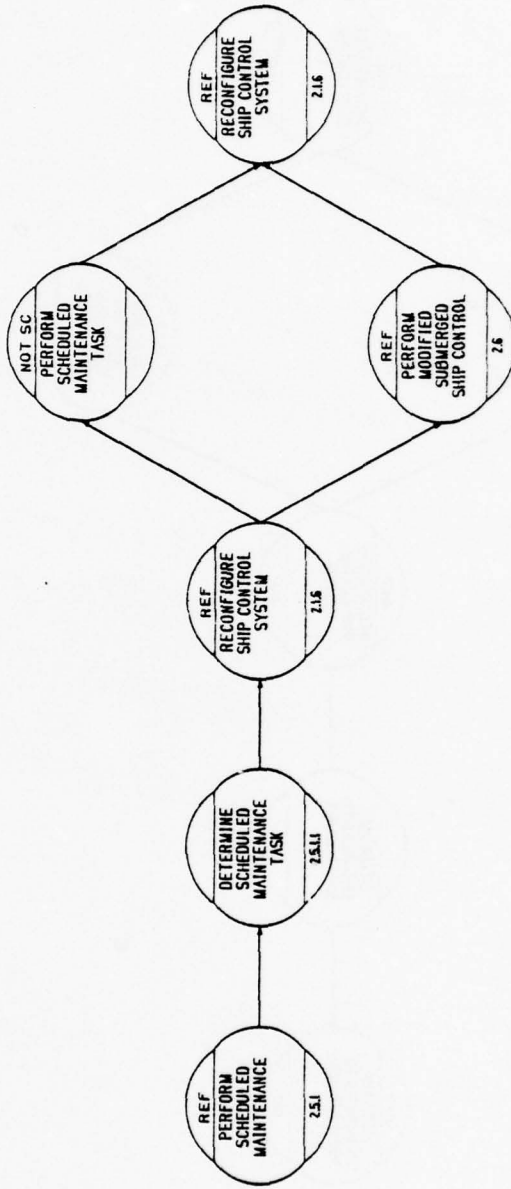

C78-1091/301

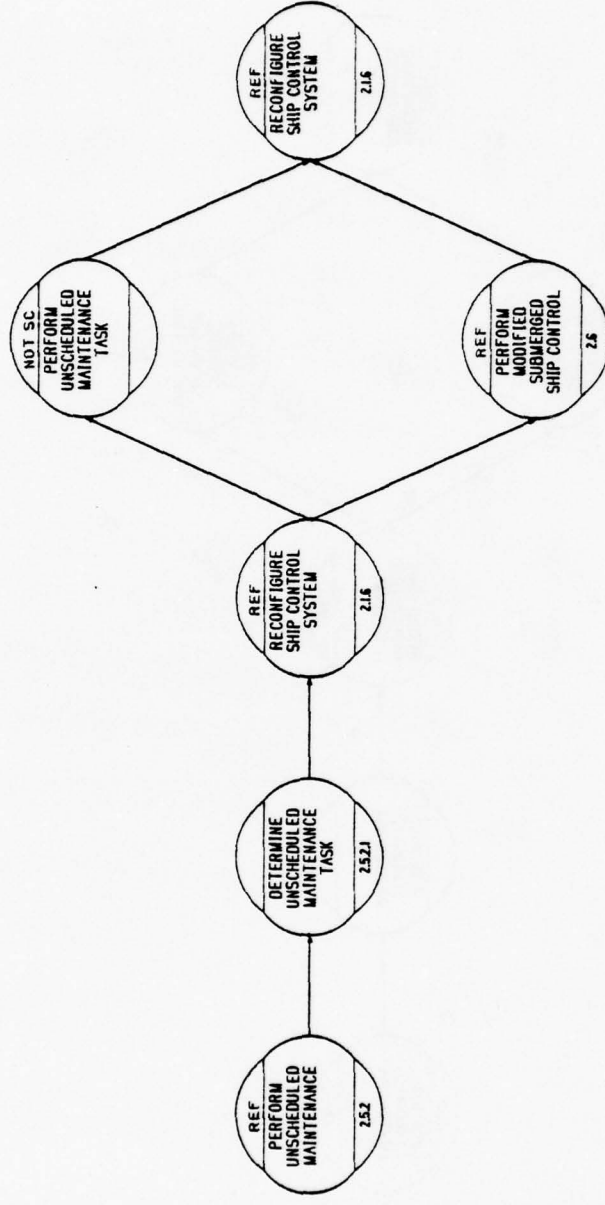

C78-1091/301

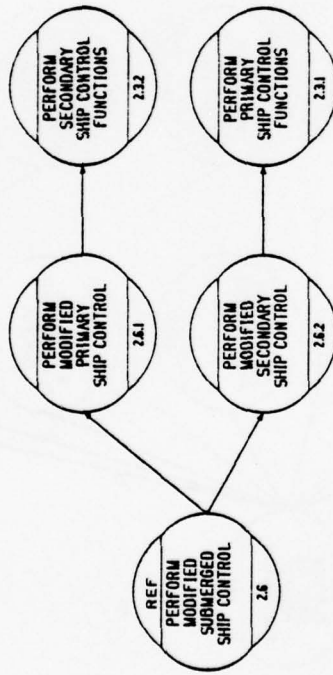

C78-1091/301

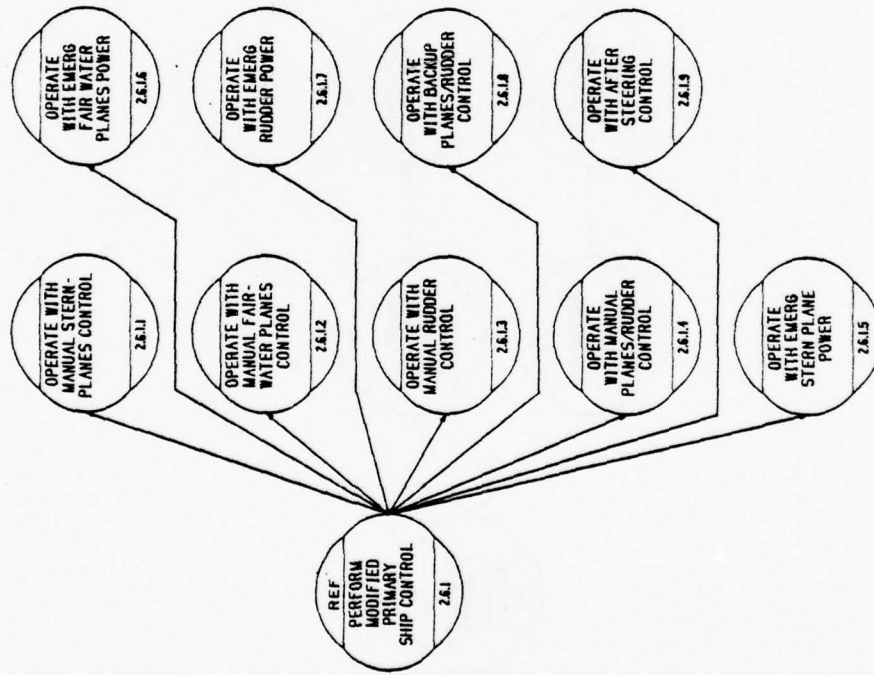

C78-1091/301

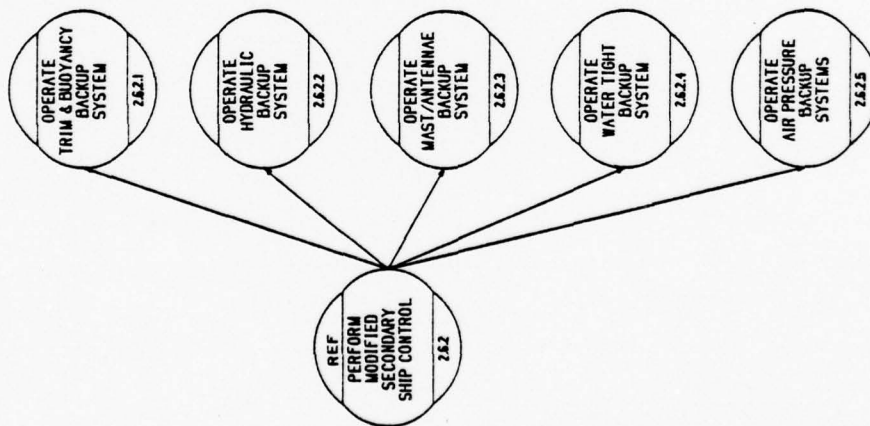

C78-109/301

APPENDIX B
FOUR-MAN CREW FUNCTIONAL ALLOCATION TABLE

ASCOP FUNCTIONAL ALLOCATION TABLE

FUNCTION: 2.1 Maintain Ships Safety		CREW SIZE: 4	
Subfunction and Equipment	Equipment Process	Operator Task	Position
2.1.1 Monitor Critical Functions			
2.1.1.1 Monitor Planes/Rudder Failure	Display of actual and commanded planes/rudder position and rate	Readout and compare actual and commanded planes/rudder position and rate	FW/Helm SP
2.1.1.1.1 Compare Commanded and Actual Planes/Rudder Response		Mental comparison of actual/commanded planes/rudder position and rate	FW/Helm
2.1.1.1.2 Decide Response In/Out of Tolerance		Compare discrepancy with mentally stored tolerance. Decide in/out of tolerance.	FW/Helm SP
2.1.1.2 Monitor Fire	No direct fire monitoring equipment	Receive verbal report	BCPO
2.1.1.2.1 Detect Smoke		Receive verbal smoke report. Dispatch casualty repair team. Sound Alarm.	BCPO
2.1.1.2.2 Receive Fire Report		Receive verbal fire report. Dispatch casualty team. Sound Alarm.	BCPO
2.1.1.3 Monitor Flooding	Sensors, where available, trigger alarm.	Monitor alarms, receive verbal reports, take action.	BCPO
2.1.1.3.1 Sense Water Influx	Sensors, where available, trigger alarm.	Monitor alarms, dispatch casualty team, inform OOD.	BCPO

ASCOP FUNCTIONAL ALLOCATION TABLE

FUNCTION: 2.1 Maintain Ships Safety (continued)		CREW SIZE: 4	Position
Subfunction and Equipment	Equipment Process	Operator Task	
2.1.1.3.2 Observe Excess Water		Receive verbal report, dispatch casualty team, inform OOD.	BCPO
2.1.1.4 Monitor Power Failure	Power monitoring automatic	Reconfigure, call maintenance, sound power alarm (General)	BCPO
2.1.1.4.1 Sense Power Loss	Sense power failure. Display alarm.	Note failure, evaluate, send casualty team, sound general alarm. Inform OOD.	BCPO
2.1.1.4.2 Observe Open Fuse		Observe local fuse indication. Replace fuse. Call maintenance if required.	BCPO
2.1.1.5 Monitor Navigation Center Failure	Failure displayed on dedicated common alarm indicator.	Note failure, evaluate. Reconfigure if required. Inform ship control team	D0
2.1.1.5.1 Receive Alarm Notification	Failure displayed.	Note failure, repair, reconfigure, call maint. inform SP and FW/Helm	D0
2.1.1.5.2 Perform Indicator/Maneuver Test	Display planes/rudder angles and course/course rate and depth/depth rate	Move ship control, observe change in rate, judge failure	SP FW/Helm
2.1.1.6 Monitor Battery Failure	No direct tie between remote sensor and SCS	Forward auxiliary electrician periodically monitors battery room	Forward aux. elect.
2.1.1.6.1 Test Battery Room Hydrogen Level	Sense hydrogen level display	Report hydrogen level Receive report - send repair party as required.	Fwd Aux. Elect. BCPO

ASCOP FUNCTIONAL ALLOCATION TABLE

FUNCTION: 2.1 Maintain Ships Safety (continued)		CREW SIZE: 4	
Subfunction and Equipment	Equipment Process	Operator Task	Position
2.1.1.7 Monitor SDMS Failure	DNA	DNA	
2.1.1.7.1 Detect Failure	DNA	DNA	
2.1.1.8 Monitor Collision	No automatic monitor	General collision alarm activated on command from OOD.	BCPO
2.1.1.8.1 Sense Collision	Dedicated general collision alarm	Observe collision or receive report. Sound alarm. Send repair team.	BCPO
2.1.1.8.2 Observe Collision Situation	Dedicated general collision alarm.	Receive collision report from OOD. Sound alarm. Send repair team.	BCPO
2.1.1.8.3 Sense Torpedo Attack	Dedicated general collision alarm.	Receive torpedo report from sonar. Sound alarm.	BCPO
2.1.1.8.4 Sense Sonar Signal Close Aboard	Dedicated general collision alarm.	Receive collision report from sonar. Sound alarm if ordered.	BCPO
2.1.1.9 Monitor Automatic Ship Control Failure	Automatic sensing.	Manual reconfiguration. Manual test available.	
2.1.1.9.1 Sense Failure	Sense failure. Display failure.	Observe failure. Recon-figure steering mode. Steer manually.	DO FW/HeIm SP

ASCOP FUNCTIONAL ALLOCATION TABLE

FUNCTION: 2.1 Maintain Ships Safety (continued)		CREW SIZE: 4	
Subfunction and Equipment	Equipment Process	Operator Task	Position
2.1.2 Detect Critical Failure			
2.1.2.1 Lose Reactor Power (High Speed Dive)	Auto detection and reconfigure power	Note alarm. Report to steersmen. Reconfigure steering.	D0
2.1.2.2 Stern Plane Jam (High Speed)	Normal SP indicator Backup SP indicator	Observe difference. Decide meter or stern plane. Report jam	SPO
2.1.2.3 Flooding (Critical Locations)	See 2.1.1.3		
2.1.2.4 Fire (Critical Locations)	See 2.1.1.2		
2.1.2.5 Lose Electrical Power (Shipwide)	Automatic power switch if available.	Observe light loss. Reconfigure if required.	D0
2.1.2.6 Collision	See 2.1.1.8		
2.1.2.7 Lose Depth Sensing		Compare depth gauges. Decide failure. Report failure.	D0
2.1.2.8 Lose Major SCS Subsystem	Auto sensing - common alarm display	Note failure. Reconfigure as required.	D0

ASCOF FUNCTIONAL ALLOCATION TABLE

FUNCTION: 2.1 Maintain Ships Safety (continued) Subfunction and Equipment	Equipment Process	CREW SIZE: 4 Operator Task	Position
2.1.3 Detect Critical System Failure Trend			
2.1.3.1 Lose Reactor Power (High Speed Dive)		Not local capability	
2.1.3.2 Stern Plane Jam (High Speed)		Not local capability	
2.1.3.3 Flooding (Critical Locations)		Monitor changes to bilge level. Estimate impact.	BCPO
2.1.3.4 Fire (Critical Locations)		Receive inspection reports of unsafe areas.	BCPO
2.1.3.5 Lose Electrical Power (Shipwide)		Not local capability	
2.1.3.6 Collision		DNA	
2.1.3.7 Lose Depth Sensing		Mental recall of increasing meter lag	DO
2.1.3.8 Lose Major SCS Subsystem		Monitor thresholds where available	BCPO

ASCOF FUNCTIONAL ALLOCATION TABLE

FUNCTION: 2.1 Maintain Ships Safety (continued)		CREW SIZE: 4	
Subfunction and Equipment	Equipment Process	Operator Task	Position
2.1.4 Identify Failed System(s)			
2.1.4.1 Lose Reactor Power (High Speed Dive)	Automatic identification.	DNA	
2.1.4.2 Stern Plane Jam (High Speed)		Identify meter, hyd, or mech	SP0
2.1.4.3 Flooding (Critical Locations)		Identify from verbal reports	BCP0
2.1.4.4 Fire (Critical Locations)		Identify from verbal reports	
2.1.4.5 Lose Electrical Power (Shipwide)		DNA	
2.1.4.6 Collision		Identify from verbal reports and/or common alarms	BCP0
2.1.4.7 Lose Depth Sensing		Identify meter or sensor failure	SP0
2.1.4.8 Lose Major SCS Subsystem		Identify from common alarm	BCP0

ASCOP FUNCTIONAL ALLOCATION TABLE

FUNCTION: 2.1 Maintain Ships Safety (continued) Subfunction and Equipment	Equipment Process	CREW SIZE: 4 Operator Task	Position
2.1.5 Identify Failing System(s)	VOID		
2.1.5.1 Analyze Predicted Failure			
2.1.5.2 Identify Potential System/ Subsystem Failure			

ASCOP FUNCTIONAL ALLOCATION TABLE

FUNCTION: 2.1 Maintain Ships Safety (continued)		CREW SIZE: 4	
Subfunction and Equipment	Equipment Process	Operator Task	Position
2.1.6 Take Appropriate Action			
2.1.6.1 Determine Impact of System/ Subsystem Degradation	No automatic functions		
2.1.6.1.1 Analyze Impact		Analyze impact	DO BCPO OOD
2.1.6.2 Take Necessary Action	No automatic functions		
2.1.6.2.1 Modify Operating Plan		Modify plan, if required.	DO DO BCPO
2.1.6.2.2 Reconfigure Operating Mode		Change code, if required.	DO BCPO
2.1.6.2.3 Report Failure to Authority		Report failure, if required.	DO BCPO
2.1.6.2.4 Dispatch Casualty Repair Team		Dispatch casualty repair team, if required.	BCPO
2.1.6.2.5 Shift Ballast		Shift ballast, if required.	BCPO

ASCOP FUNCTIONAL ALLOCATION TABLE

FUNCTION: 2.1 Maintain Ships Safety (continued) Subfunction and Equipment	Equipment Process	CREW SIZE: 4 Operator Task	Position
2.1.6.2.6 Sound Alarm		Sound general alarm, if required.	BCPO
2.1.6.2.7 Receive Data (Reports)		Receive data reports (verbal)	BCPO

ASCOPE FUNCTIONAL ALLOCATION TABLE

FUNCTION: 2.3 Perform Submerged Ship Control		CREW SIZE: 4	
Subfunction and Equipment	Equipment Process	Operator Task	Position
2.3.1 Perform Primary Ship Control Functions			
2.3.1.1 Perform Depth Control	Normal operating mode is manual with automatic depth holding available.	Depth is manually controlled at high speed by SPO and at low speed by FW/Helm	
2.3.1.1.1 Determine Ordered Depth and Accuracy	No direct input of commanded depth from OOD	Operator enters commanded depth - Accuracy is verbally commanded.	D0
2.3.1.1.1.1 Receive Verbal Command		Receive ordered depth and accuracy from OOD.	D0
2.3.1.1.1.2 Convert Command to Appropriate Form		Enter ordered depth verbally order depth and accuracy	D0
2.3.1.1.2 Determine Actual Depth and Error	Depth error determined by depth keeping processor in auto mode	Depth error determined by operator in normal mode.	
2.3.1.1.2.1 Sense Depth	Sense and display pressure depth with necessary corrections	Note actual depth	D0 SP FW/Helm
2.3.1.1.2.2 Compare Ordered and Actual Depth	Compare actual and ordered depth in auto mode.	Compare actual and ordered depth in normal mode.	D0
2.3.1.1.2.3 Determine Depth Error	Determine depth error in auto mode.	Determine depth error in normal mode.	D0

ASCOF FUNCTIONAL ALLOCATION TABLE

FUNCTION: Subfunction and Equipment	2.3 Perform Submerged Ship Control	Equipment Process	CREW SIZE: 4 Operator Task	Position
2.3.1.1.3 Determine Ship Response Characteristics			Primarily manual function	
2.3.1.1.3.1 Determine Ship Hydrodynamics			Determine ship hydro-dynamics based on experience	D0
2.3.1.1.3.2 Determine Water Conditions			Determine water conditions from sonar	D0
2.3.1.1.3.3 Determine Ship's Speed			Read speed from Indicator	D0
2.3.1.1.3.4 Determine Ship's Buoyancy and Trim	Display tank quantities. Display pitch angle.		Monitor tank quantities. Observe control frequency Monitor ship pitch angle.	D0
2.3.1.1.4 Adjust Planes to Change Depth	Controlled by processor in auto mode		Controlled by operators in manual mode	
2.3.1.1.4.1 Decide which Planes to Use			Decide which planes to use	D0
2.3.1.1.4.2 Decide/Set Plane Angle Limit	Automatic maintenance of plane angle limit once limit is set		Decide/set plane angle limit	D0
2.3.1.1.4.3 Decide/Set Pitch Angle Limit	Automatic maintenance of pitch angle once limit is set		Decide/set pitch angle limit	D0

ASCOF FUNCTIONAL ALLOCATION TABLE

FUNCTION: 2.3 Perform Submerged Ship Control (Continued)		CREW SIZE: 4	
Subfunction and Equipment	Equipment Process	Operator Task	Position
2.3.1.1.4.4 Decide/Set Depth Rate	Automatic maintenance of maximum depth rate once set	Decide/set depth rate	D0
2.3.1.1.4.5 Move Planes to Required Angle	Automatic planes movement in auto mode.	Move plane angle control required amount in normal mode	SPO FW/Helm
2.3.1.1.4.6 Predict Time to End Maneuver	Automatic computation of time to end maneuver in auto mode.	Mental computation of time to move control in normal mode.	SPO FW/Helm
2.3.1.1.4.7 Move Planes to End Maneuver	Automatic planes movement in auto mode.	Manual movement of control to end maneuver	SPO FW/Helm
2.3.1.1.6 Adjust Trim/Buoyancy for Ordered Depth		Decision and control is manual	
2.3.1.1.6.1 Determine Water Density		Operator function	
2.3.1.1.6.1.1 Read Sound Velocity Profile		Read sound velocity profile	D0
2.3.1.1.6.1.2 Read Temperature Charts		Read temperature charts	D0
2.3.1.1.6.2 Determine Past Water Conditions		Review past water conditions in log	D0

ASCOP FUNCTIONAL ALLOCATION TABLE

FUNCTION: Subfunction and Equipment	2.3 Perform Submerged Ship Control (continued)	Equipment Process	CREW SIZE: 4	
			Operator Task	Position
2.3.1.1.6.2.1 Read Diving Log			Determine ship behavior from diving log	D0
2.3.1.1.6.2.2 Read Past Sound Velocity Profiles			Read past SVPs to determine trend	D0
2.3.1.1.6.2.3 Read NAVSAT Data			Read NAVSAT Data to determine location. Decide water conditions	D0
2.3.1.1.6.3 Determine Ship Buoyancy and Trim			Manual function	
2.3.1.1.6.3.1 Determine Planes Activity			Observe planes activity, infer trim	D0
2.3.1.1.6.3.2 Determine Ship's Activities			Determine ships present and expected activities Judge buoyancy and trim	D0
2.3.1.1.6.4 Determine Desired Buoyancy			Manual function	
2.3.1.1.6.4.1 Consult Tables			Consult buoyancy tables	D0
2.3.1.1.6.4.3 Receive Ordered Buoyancy			Receive commanded buoyancy from OOD	D0

ASCOP FUNCTIONAL ALLOCATION TABLE

FUNCTION: 2.3 Perform Submerged Ship Control (continued) Subfunction and Equipment	Equipment Process	CREW SIZE: 4 Operator Task	Position
2.3.1.1.6.5 Determine Desired Trim		Manual function	D0
2.3.1.1.6.5.1 Receive Ordered Trim		Receive commanded trim	BCPO
2.3.1.1.6.6 Determine Water Movement		Manual function	
2.3.1.1.6.6.1 Determine Acceptable Ship's Noise Level		Receive noise level orders. Decide acceptable noise level	D0
2.3.1.1.6.6.2 Determine Acceptable Water Transfer Time		Decide acceptable water transfer time	D0
2.3.1.1.6.6.4 Determine Water Tank Status	Display water tank quantities	Determine water tank status	D0
2.3.1.1.6.7 Move Water		Manual control function	
2.3.1.1.6.7.1 Flood			
2.3.1.1.6.7.1.1 Select Destination		Select destination and quantity	D0

ASCOP FUNCTIONAL ALLOCATION TABLE

FUNCTION: 2.3 Perform Submerged Ship Control (continued)		CREW SIZE: 4	
Subfunction and Equipment	Equipment Process	Operator Task	Position
2.3.1.1.6.7.1.2 Open Hull and Backup Valves	Open hull and backup valves	Actuate hull and backup valve controls	BCPO
2.3.1.1.6.7.1.3 Monitor Flood Rate	Display transfer rate	Observe transfer rate Decide adequate/inadequate	BCPO
2.3.1.1.6.7.1.4 Close Hull & Backup Valves & Destination Valves	Close hull, backup and destination valves	actuate hull backup and destination valve controls	BCPO
2.3.1.1.6.7.2 Pump to Sea			
2.3.1.1.6.7.2.1 Select Trim or Drain Pump	Select trim or drain pump.	Actuate trim or drain pump selection controls	BCPO
2.3.1.1.6.7.2.2 Start Prime Pump	Start prime pump	Actuate prime pump Start control	BCPO
2.3.1.1.6.7.2.3 Monitor Pressure & Suction	Display pressure and suction quantities	Monitor pressure and suction	BCPO
2.3.1.1.6.7.2.4 Open Source Valve	Open source valve	Activate source valve switch	BCPO
2.3.1.1.6.7.2.5 Start Main Pump	Start main pump	Activate main pump start switch	BCPO

ASCOP FUNCTIONAL ALLOCATION TABLE

FUNCTION: 2.3 Perform Submerged Ship Control (continued)	Equipment Process	CREW SIZE: 4 Operator Task	Position
Subfunction and Equipment			
2.3.1.1.6.7.2.6 Monitor Pump Speed and Current	Display pump speed and current	Monitor pump speed and current	BCPO
2.3.1.1.6.7.2.7 Open Destination Valve	Open destination valve	Actuate destination valve switch	BCPO
2.3.1.1.6.7.2.8 Monitor Water Value	Display water transfer value	Monitor water transfer valve	BCPO
2.3.1.1.6.7.2.9 Close Destination Valve	Close destination valve	Actuate destination valve control	BCPO
2.3.1.1.6.7.2.10 Stop Pump	Stop main pump	Actuate main pump control	BCPO
2.3.1.1.6.7.2.11 Close Source Valve	Close source valve	Actuate source valve control	BCPO
2.3.1.1.6.7.3 Pump Tank to Tank	Same as 2.3.1.1.6.7.2		
2.3.1.1.7 Adjust Trim/Buoyancy to Maintain Low Speed Depth		Manual function	

ASCOP FUNCTIONAL ALLOCATION TABLE

FUNCTION: 2.3 Perform Submerged Ship Control (continued)		CREW SIZE: 4	Position
Subfunction and Equipment	Equipment Process	Operator Task	
2.3.1.1.7.1 Determine Depth Rate and Acceleration	Display depth/time and change	Determine depth rate and acceleration mentally	D0
2.3.1.1.8 Adjust Planes to Maintain Ordered High Speed Depth	Move stern planes	Move stern planes control lever to change depth	SP0
2.3.1.2 Perform Course Control	Normal operating mode is manual with automatic course control available	Course is manually controlled by FW/Helm	
2.3.1.2.1 Determine Ordered Course and Accuracy		Commanded course and accuracy received verbally from conn	
2.3.1.2.1.1 Receive Verbal Order from Conn		Receive commanded course and accuracy, enter course	FW/Helm
2.3.1.2.2 Determine Actual Course			Conn
2.3.1.2.2.1 Sense Gyro Output	Sense gyro output. Display course.	Monitor course	FW/Helm
2.3.1.2.3 Determine Ship Response Characteristics		Determine ship response characteristics	Conn
2.3.1.2.4 Adjust Rudder to Change Course	Move rudder	Move rudder control to change course	FW/Helm

ASCOP FUNCTIONAL ALLOCATION TABLE

FUNCTION: 2.3 Perform Submerged Ship Control (continued)		CREW SIZE: 4	Position
Subfunction and Equipment	Equipment Process	Operator Task	Position
2.3.1.2.4.1 Determine/Set Roll Limit	Maintain rudder control within roll limits	Determine/set roll limit	D0
2.3.1.2.4.2 Determine/Set Rudder Limit	Maintain rudder control within rudder limit	Determine/set rudder limit	D0
2.3.1.2.4.3 Determine Rudder Angle Required		Determine/order rudder angle required	Conn
2.3.1.2.4.4 Set Required Rudder Angle	Position rudder to controlled angle.	Set rudder control to position rudder to required angle	FW/HeIm
2.3.1.2.4.5 Predict Time To End Maneuver		Predict time to end maneuver to achieve required course	Conn FW/HeIm
2.3.1.2.4.6 Move Rudder to End Maneuver	Position rudder to controlled angle.	Move rudder control to end maneuver	FW/HeIm
2.3.1.2.5 Adjust Rudder to Maintain Course	Position rudder to controlled position	Move rudder control to maintain course	FW/HeIm
2.3.1.2.5.1 Determine Yaw Acceleration	Sense yaw acceleration. Display	Monitor yaw acceleration - Convert to required rudder change	FW/HeIm
2.3.1.2.5.2 Move Rudder to End Correction Maneuver	Position rudder to controlled angle	Move rudder control to end correction maneuver	FW/HeIm

ASCOP FUNCTIONAL ALLOCATION TABLE

FUNCTION: 2.3 Perform Submerged Ship Control (continued)		CREW SIZE: 4	Position
Subfunction and Equipment	Equipment Process	Operator Task	
2.3.1.3 Perform Speed Control		Manual function	
2.3.1.3.1 Determine Ordered Speed		Commanded course and accuracy received from Conn	
2.3.1.3.1.1 Receive Verbal Orders		Receive speed command	D0
2.3.1.3.2 Determine Actual Speed	Speed measured by sensors	Speed monitored by operator	
2.3.1.3.2.1 Sense Speed	Sense speed. Display	Monitor speed	D0
2.3.1.3.3 Determine Propulsion Change Required		Propulsion change manually determined	
2.3.1.3.3.1 Determine Direction and Size of Error		Compare commanded and actual speed. Note error	Conn D0
2.3.1.3.3.2 Determine Change in RPM Required		Determine RPM required	D0
2.3.1.3.3.3 Determine Change in Percent Propulsion Required		Determine percent propulsion change required	Conn

ASCOP FUNCTIONAL ALLOCATION TABLE

FUNCTION: 2.3 Perform Submerged Ship Control (continued)	Equipment Process	CREW SIZE: 4 Operator Task	Position
Subfunction and Equipment			
2.3.1.3.4 Change Propulsion to Change Speed	Speed change accomplished in engine room	Adjust speed	Engine Room Operator
2.3.1.3.4.1 Order Percent Propulsion Change	Engine order telegraph or intercommunication set	Order percent propulsion change	D0
2.3.1.3.4.2 Order RPM Change	Intercommunication set	Order RPM change	D0
2.3.1.3.4.3 Receive Percent Propulsion Change Acknowledgement	Engine order telegraph or intercommunication set	Receive percent propulsion change acknowledgement	D0
2.3.1.3.4.4 Receive RPM Change Acknowledgement	Intercommunication set	Receive RPM change acknowledgement	D0
2.3.1.3.5 Change Propulsion to Maintain Speed	Same as 2.3.1.3.4		

ASCP FUNCTIONAL ALLOCATION TABLE

FUNCTION: 2.3 Perform Submerged Ship Control (continued)		CREW SIZE: 4	Position
Subfunction and Equipment	Equipment Process	Operator Task	
2.3.2 Monitor Ship Control Systems			
2.3.2.1 Monitor and Control Hydraulics		Hydraulic system monitoring and control is essentially manual	
2.3.2.1.1 Monitor External Hydraulic Line Pressure	Sense/display external line pressure	Monitor external line pressure	BCPO
2.3.2.1.2 Monitor External Hydraulic Accumulator Quantity	Sense/display external accumulator quantity	Monitor external accumulator quantity	BCPO
2.3.2.1.3 Monitor Port Hydraulic Line Pressure	Sense/display port line pressure	Monitor port line pressure	BCPO
2.3.2.1.4 Monitor Port Hydraulic Accumulator Quantity	Sense/display port accumulator quantity	Monitor port accumulator quantity	BCPO
2.3.2.1.5 Monitor Lead Hydraulic Line Pressure	Sense/display lead line pressure	Monitor lead line pressure	BCPO
2.3.2.1.6 Monitor Lead Hydraulic Accumulator Quantity	Sense/display lead accumulator quantity	Monitor lead accumulator	BCPO
2.3.2.1.7 Monitor Starboard Hydraulic Line Pressure	Sense/display starboard line pressure	Monitor starboard line pressure	BCPO

ASCOP FUNCTIONAL ALLOCATION TABLE

FUNCTION: 2.3 Perform Submerged Ship Control (continued)		CREW SIZE: 4	
Subfunction and Equipment	Equipment Process	Operator Task	Position
2.3.2.1.8 Monitor Starboard Hydraulic Accumulator Quantity	Sense/display starboard accumulator quantity	Monitor starboard accumulator quantity	BCPO
2.3.2.1.9 Monitor Steering and Diving Hydraulic Line Pressure	Sense/display steering and diving line pressure	Monitor steering and diving line pressure	BCPO
2.3.2.1.10 Monitor Steering and Diving Hydraulic Accumulator #1 Quantity	Sense/display S&D accumulator #1 quantity	Monitor S&D accumulator #1 quantity	BCPO
2.3.2.1.11 Monitor Steering and Diving Hydraulic Accumulator #2 Quantity	Sense/display S&D accumulator #2 quantity	Monitor S&D accumulator #2 quantity	BCPO
2.3.2.1.12 Monitor and Control External Pump #1 Status	Sense/display ext. pump #1 status Start/stop ext. pump #1	Monitor pump #1 status Switch pump #1 OFF/ON	BCPO
2.3.2.1.13 Monitor and Control External Pump #2 Status	Sense/display ext. pump #2 status Start/stop ext. pump #2	Monitor pump #2 Switch pump #2 ON/OFF	BCPO
2.3.2.1.14 Monitor and Control Port Pump Status	Sense/display port pump status Start/stop port pump	Monitor port pump status Switch port pump ON/OFF	BCPO
2.3.2.1.15 Monitor and Control Lead Pump Status	Sense/display lead pump status Start/stop lead pump	Monitor lead pump status Switch lead pump ON/OFF	BCPO
2.3.2.1.16 Monitor and Control Starboard Pump Status	Sense/display starboard pump status Start/stop starboard pump	Monitor starboard pump status Switch starboard pump ON/OFF	BCPO

ASCOPE FUNCTIONAL ALLOCATION TABLE

FUNCTION: 2.3 Perform Submerged Ship Control (Continued)		CREW SIZE: 4	
Subfunction and Equipment	Equipment Process	Operator Task	Position
2.3.2.1.17 Monitor and Control S&D Pump #1 Status	Sense/display S&D pump #1 status Start/stop S&D pump #1	Monitor S&D pump #1 status Switch S&D pump #1 ON/OFF	BCPO
2.3.2.1.18 Monitor and Control S&D Pump #2 Status	Sense/display S&D pump #2 status Start/stop S&D pump #2	Monitor S&D pump #1 status Switch S&D pump #1 ON/OFF	BCPO
2.3.2.1.19 Monitor Stored Energy	Sense/display stored energy	Monitor stored energy	BCPO
2.3.2.1.20 Monitor Hydraulic System Status	Sense/display hydraulic system status	Monitor hydraulic system status	BCPO
2.3.2.2 Monitor and Control Hull Openings		Manual function	
2.3.2.2.1 Monitor Aft Escape Hatch	Sense/display aft escape hatch status	Monitor aft escape hatch status	BCPO
2.3.2.2.2 Monitor Bridge Access	Sense/display bridge access status	Monitor bridge access status	BCPO
2.3.2.2.3 Monitor Forward Escape Hatch	Sense/display fwd. escape hatch status	Monitor fwd. escape hatch status	BCPO
2.3.2.2.4 Monitor WPN Shipping Hatch	Sense/display WPN shipping hatch status	Monitor WPN shipping hatch status	BCPO

ASOP FUNCTIONAL ALLOCATION TABLE

FUNCTION: 2.3 Perform Submerged Ship Control (continued)		CREW SIZE: 4	
Subfunction and Equipment	Ship Control	Operator Task	Position
	Equipment Process		
2.3.2.2.5 Monitor and Control Hover Backup Valve	Sense/display hover backup valve status Open/close hover backup valve	Monitor hover backup valve status Switch valve open/close	BCPO
2.3.2.2.6 Monitor and Control Hover Hull Valve	Sense/display hover hull valve status Open/close hover hull valve	Monitor hover hull valve status. Switch valve open/close.	BCPO
2.3.2.2.7 Monitor and Control Trim Backup Valve	Sense/display trim backup valve status Open/close backup valve	Monitor trim backup valve status. Switch valve open/close.	BCPO
2.3.2.2.8 Monitor and Control Trim Hull Valve	Sense/display trim hull valve status. Open/close trim hull valve	Monitor trim hull valve status. Switch valve open/close.	BCPO
2.3.2.2.9 Monitor Induction Backup Valve	Sense/display induction backup valve status	Monitor induction backup valve status	BCPO
2.3.2.2.10 Monitor and Control Induction Hull Valve	Sense/display induction hull valve status. Open/close induction hull valve	Monitor induction hull valve status. Switch valve open/close	BCPO
2.3.2.2.11 Monitor Exhaust Backup Valve	Sense/display exhaust backup valve status	Monitor exhaust backup valve status	BCPO
2.3.2.2.12 Monitor and Control Exhaust Hull Valve	Sense/display exhaust hull valve status Open/close exhaust hull valve	Monitor exhaust hull valve status. Switch valve open/close	BCPO
2.3.2.3 Monitor Water Tight Compartments		Manual function	

ASCOP FUNCTIONAL ALLOCATION TABLE

FUNCTION: 2.3 Perform Submerged Ship Control (continued)		CREW SIZE: 4	Position
Subfunction and Equipment	Equipment Process	Operator Task	
2.3.2.3.1 Receive Verbal Forward Compartment Status		Receive verbal report of compartment status	BCPO
2.3.2.3.2 Receive Verbal Aft Compartment Status		Receive verbal report of aft compartment status	BCPO
2.3.2.4 Monitor Hydrogen Concentration		Manual function	
2.3.2.4.1 Sense Hydrogen Concentration	Sense/display hydrogen concentration in battery room	Monitor/transmit hydrogen concentration	FWD Aux. Elet.
2.3.2.4.2 Receive Reports of Hydrogen Concentration		Receive reports of hydrogen concentration	BCPO
2.3.2.5 Monitor and Control Air Pressure Systems		Manual function	
2.3.2.5.1 Monitor 700 PSIG Air Pressure	Sense/display 700 PSIG air pressure status	Monitor 700 PSIG air pressure status	BCPO
2.3.2.5.2 Monitor 4500 PSIG Air Pressure	Sense/display 4500 PSIG air pressure status	Monitor 4500 PSIG air pressure status	BCPO
2.3.2.5.3 Monitor/Control High Pressure Air Bank #1	Sense/display air bank #1 status Open/shut bank #1 valve	Monitor air bank #1 Switch bank #1 valve open/shut	BCPO

ASCP FUNCTIONAL ALLOCATION TABLE

FUNCTION: 2.3 Perform Submerged Ship Subfunction and Equipment	Control (continued)	Equipment Process	CREW SIZE: 4 Operator Task	Position
2.3.2.5.4 Monitor/Control High Pressure Air Bank #2	Sense/display air bank #2 status Open/shut bank #2 valve		Monitor air bank #2 Switch bank #2 valve open/ shut	BCPO
2.3.2.5.5 Monitor/Control High Pressure Air Bank #3	Sense/display air bank #3 status Open/shut bank #3 valve		Monitor air bank #3 Switch bank #3 valve open/ shut	BCPO
2.3.2.5.6 Monitor/Control High Pressure Air Bank #4	Sense/display air bank #3 status Open/shut bank #4 valve		Monitor air bank #4 Switch bank #4 valve open/ shut	BCPO
2.3.2.5.7 Monitor/Control High Pressure Air Bank #5	Sense/display bank #5 status Open/shut bank #4 valve		Monitor air bank #4 Switch bank #5 valve open/ shut	BCPO
2.3.2.6 Monitor and Control SCS Electric System			Manual Function	
2.3.2.6.1 Monitor and Control Normal/Emergency Stern Plane Power	Sense/display normal emergency stern plan power. Change power source to normal/emergency		Monitor stern plan power status. Switch to normal. emergency	BCPO
2.3.2.6.2 Monitor and Control Normal/Emergency Fairwater Plane Power	Sense/display normal emergency fairwater plane power. Change power to normal/emergency		Monitor fairwater power status. Switch to normal/emergency	BCPO
2.3.2.6.3 Monitor and Control Normal/Emergency Rudder Power	Sense/display normal emergency rudder power. Change power to normal/emergency.		Monitor rudder power status. Switch to normal/emergency	BCPO
2.3.2.6.4 Monitor and Control SCS Power	Sense/display SCS power status Energize/deenergize console power		Monitor SCS power status Switch console power on/off	BCPO

ASCP FUNCTIONAL ALLOCATION TABLE

FUNCTION: 2.3 Perform Submerged Ship Control (continued)		CREW SIZE: 4	Position
Subfunction and Equipment	Equipment Process	Operator Task	
2.3.2.6.5 Monitor and Control Critical Circuit Power	Sense/display critical circuit power status. Energize/deenergize critical circuit power	Monitor critical circuit power. Switch critical circuit power on/off	BCPO
2.3.2.7 Monitor and Control Processor		DNA	
2.3.2.7.1 Recognize Failure		DNA	
2.3.2.7.2 Select Backup Mode (Reconfigure)		DNA	
2.3.2.8 Monitor and Control Masts/Antenna		Manual Function	
2.3.2.8.1 Monitor Periscopes and Shrouds	Sense/display periscope/shroud status	Monitor periscope/shroud status	BCPO
2.3.2.8.2 Monitor and Control Navigation Light	Sense/display navigation light status. Turn NAV light on/off	Monitor navigation light status. Switch NAV light on/off	BCPO
2.3.2.8.3 Monitor and Control Multi-Purpose Masts 1 & 2	Sense/display masts 1 & 2 status. Raise/lower masts 1 & 2	Monitor masts 1 & 2 status. Switch masts up/down	BCPO
2.3.2.8.4 Monitor and Control RDF Mast	Sense/display RDF mast status. Raise/lower RDF mast	Monitor RDF mast status. Switch RDF mast up/down	BCPO

ASCOP FUNCTIONAL ALLOCATION TABLE

FUNCTION: 2.3 Perform Submerged Ship Control (continued)		CREW SIZE: 4	
Subfunction and Equipment	Equipment Process	Operator Task	Position
2.3.2.8.6 Monitor and Control Induction Mast	Sense/display induction mast status. Raise/lower induction mast	Monitor induction mast status. Switch induction mast up/down.	BCPO
2.3.2.8.7 Monitor and Control Head Valve	Sense/display head valve status. Open/close head valve	Monitor head valve status. Switch head valve open/close	BCPO
2.3.2.8.8 Monitor and Control Heaters	Sense/display heater status. Turn heaters on/off	Monitor heater status. Switch heaters on/off	BCPO
2.3.2.8.9 Monitor and Control Electrode Test	Sense/display electrode test status. Turn electrode on/off	Monitor electrode test status. Switch electrode on/off	BCPO
2.3.2.8.10 Monitor and Control Towed Array	Sense/display array status. Extend/retract array. Cut cable	Monitor array status. Switch array to extend/retract. Initiate cable cut	BCPO
2.3.2.9 Monitor and Control Console Controls and Displays		Manual Function	
2.3.2.9.1 Monitor Console Indicators	Perform indicator self-test when required	Monitor console indicators detect failure. Initiate self-test	D0.BCPO SPO
2.3.2.9.2 Adjust CRT Controls		DNA	
2.3.2.9.3 Adjust Plasma Display Controls		dna	

ASCOP FUNCTIONAL ALLOCATION TABLE
 Control (continued)

FUNCTION: 2.3 Perform Submerged Ship Subfunction and Equipment	Equipment Process	CREW SIZE: 4 Operator Task	Position
2.3.2.9.4 Adjust Panel Brightness	Change panel brightness	Adjust panel brightness	DO BCPO
2.3.2.10 Monitor and Control SDMS		DNA	
2.3.2.10.1 Recognize Failure		DNA	
2.3.2.10.2 Reconfigure SDMS		DNA	
2.3.2.11 Monitor and Control MBT Vents and Emergency Blow Valves		Manual Function	
2.3.2.11.1 Monitor and Control MBT Vents	Sense/display MBT vent status Open/close MBT vents	Monitor MBT vents status. Switch vents open/close	BCPO
2.3.2.11.2 Monitor and Control Emergency Blow Valves	Sense/display emergency blow valves. Open/close emergency blow valves	Monitor emergency blow valves. Switch valves open/close	BCPO
2.3.2.12 Maintain SCS Log		Provide entries to SCS log	BCPO
2.3.2.12.1 Maintain Log of Course Changes		Provide entries to course Change log	BCPO

ASCOP FUNCTIONAL ALLOCATION TABLE

FUNCTION: 2.3 Perform Submerged Ship Subfunction and Equipment	Control (continued)	CREW SIZE: 4 Operator Task	Position
	Equipment Process		
2.3.2.12.2 Maintain Log of Depth Changes		Provide entries to depth change log	BCPO
2.3.2.12.3 Maintain Log of Speed Changes		Provide entries to speed change log	BCPO
2.3.2.12.4 Maintain Log of Casualties		Provide entries to casualty log	BCPO
2.3.2.12.5 Maintain Log of Operating Modes		Provide entries to operating mode log	BCPO

ASCOP FUNCTIONAL ALLOCATION TABLE
 (continued)

FUNCTION: 2.3 Perform Submerged Ship Control (continued)	Equipment Process	CREW SIZE: 4 Operator Task	Position
Subfunction and Equipment			
2.3.3 Perform Watch Supervisor Functions			
2.3.3.1 Supervise Forward Auxiliary-men		Supervise FWD Auxiliarymen	BCPO
2.3.3.2 Supervise Auxiliary Electrician Forward		Supervise Auxiliary Electrician Forward	BCPO
2.3.3.3 Supervise Lee Helm and Ship Control Operator		Supervise Lee Helm Supervise SPO Supervise FW/Helm	BCPO DO OOD
2.3.3.4 Perform Phone Talker Duties		Operate 1MC Circuit	BCPO
2.3.3.5 Operate 1MC Circuit			

ASCOP FUNCTIONAL ALLOCATION TABLE

FUNCTION: 2.4 Perform External Communications		CREW SIZE: 4	
Subfunction and Equipment	Equipment Process	Operator Task	Position
2.4.1 Ascent to Communication/ Periscope Depth			
2.4.2 Deploy Periscope		Manual Function	
2.4.2.1 Verify Periscope Depth		Verify ship at periscope depth	OOD
2.4.2.2 Activate Periscope Drive	Sense/display periscope status	Monitor periscope status	BCPO
2.4.2.3 Sense Periscope Fully Extended	Sense periscope fully extended. Display.	Monitor periscope fully extended	BCPO
2.4.2.4 Deactivate Periscope Drive	Deactivate periscope drive	DNA	

ASCOP FUNCTIONAL ALLOCATION TABLE

FUNCTION: 2.5 Perform Scheduled/Unscheduled Maintenance	Equipment Process	CREW SIZE: 4	Operator Task	Position
Subfunction and Equipment				
2.5.1 Perform Scheduled Maintenance				
2.5.1.1 Determine Scheduled Maintenance Task		Not SCS Function		
2.5.2 Perform Unscheduled Maintenance		Not SCS Function		
2.5.2.1 Determine Unscheduled Maintenance Task		Not SCS Function		

ASCOP FUNCTIONAL ALLOCATION TABLE

FUNCTION: 2.6 Perform Modified Submerged Ship Control Subfunction and Equipment	Equipment Process	CREW SIZE: 4 Operator Task	Position
2.6.1 Perform Modified Primary Ship Control			
2.6.1.1 Operate With Manual Stern-Planes Control	Sense/display sternplanes position, depth, dive angle	Perform sternplanes steering manually (Primary Mode)	SPO
2.6.1.2 Operate with Manual Fairwater Planes Control	Sense/display fairwater planes position, depth, dive angle	Perform fairwater planes steering manually (Primary Mode)	FW/Helm
2.6.1.3 Operate with Manual Rudder Control	Sense/display rudder position, course	Perform rudder steering manually (Primary Mode)	FW/Helm
2.6.1.4 Operate with Manual Planes/Rudder Control		As Above	
2.6.1.5 Operate with Emergency	Switch to emergency SP power. Move sternplanes	Set emergency SP power Steer manually	D0/SPO SPO
2.6.1.6 Operate with Emergency	Switch to emergency FW planes power. Move FW planes.	Set emergency FW power Steer manually.	D0/FW Helm FW Helm
2.6.1.7 Operate with Emergency Rudder Power	Switch to emergency rudder Move rudder	Set emergency rudder power. Steer manually	D0/FW Helm FW Helm
2.6.1.8 Operate with Backup Planes/Rudder Control			

ASCOP FUNCTIONAL ALLOCATION TABLE

FUNCTION: 2.6 Perform Modified Submerged Ship Control (continued) Subfunction and Equipment	Equipment Process	CREW SIZE: Operator Task	Position
2.6.1.9 Operate with After Steering Control		DNA	

ASCOP FUNCTIONAL ALLOCATION TABLE

FUNCTION: 2.6 Perform Modified Submerged Ship Control (continued)	CREW SIZE: 4		Position
Subfunction and Equipment	Operator Task	Equipment Process	Position
2.6.2 Perform Modified Secondary Ship Control			
2.6.2.1 Operate Trim and Buoyancy Backup System	Remote Manual Function		
2.6.2.2 Operate Hydraulic Backup System	Remote Manual Function		
2.6.2.3 Operate Masts/Antenna Backup System	DNA		
2.6.2.4 Operate Water Tight Backup System	Remote Manual Function		
2.6.2.5 Operate Air Pressure Backup System	Remote Manual Function		

C78-109/301

APPENDIX C
THREE-MAN CREW FUNCTIONAL ALLOCATION TABLE

ASCP FUNCTIONAL ALLOCATION TABLE

FUNCTION: 2.1 Maintain Ships Safety Subfunction and Equipment	Equipment Process	CREW SIZE: 3 Operator Task	Position
2.1.1 Monitor Critical Functions			
2.1.1.1 Monitor Planes/Rudder Failure	Auto monitor of planes/rudder position and auto-ordered planes/rudder position	Previously entered commanded depth, course, speed, maneuver limits	D0
2.1.1.1.1 Compare Commanded and Actual Planes/Rudder Response	Auto comparison of ordered and actual planes/rudder position	Monitor maneuver performance. Check quality of auto monitor	SC0
2.1.1.1.2 Decide Response In/Out of Tolerance	Decide in/out of tolerance. Display "By Exception" changes made as required.	Detect failure alarm. Select detail display, Switch mode. Sound diving alarm if required.	D0 BC0
2.1.1.2 Monitor Fire	No basic fire sensors. Alarm devices spotted throughout ship. Tied to SDMS.	Monitor casualty alarm and location. Dispatch casualty team. Informs OOD.	BC0
2.1.1.2.1 Detect Smoke	Xmit nature/location of smoke in canned message. Display status.	Monitors smoke message. Reports to OOD. Sends casualty team. Update from Menu.	BC0
2.1.1.2.2 Receive Fire Report	Xmit nature/location/type of fire in canned message. Display message and	Monitor fire message, report to OOD. Send casualty team. Update from menu.	BC0
2.1.1.3 Monitor Flooding	Partial sensor monitor.	Partial operator monitor.	
2.1.1.3.1 Sense Water Influx	Sensors, where available, trigger alarm message.	Monitor flooding alarm and location. Dispatch casualty team.	BC0

ASCOP FUNCTIONAL ALLOCATION TABLE

FUNCTION: 2.1 Maintain Ships Safety (continued)		CREW SIZE: 3	
Subfunction and Equipment	Equipment Process	Operator Task	Position
2.1.1.3.2 Observe Excess Water	Canned-Message xmitters at various locations throughout ship tied to SDMS.	Monitor messages. Dispatch casualty team. Pass word	BCO
2.1.1.4 Monitor Power Failure	Sensors monitor power and xmit failures. Display on multi-format display		
2.1.1.4.1 Sense Power Loss	Sense power loss/source . Display.	Monitor alarm. Select display details, reconfigure. Report.	DO BCO
2.1.1.4.2 Observe Open Fuse		Observe fuse light. Replace fuse or reconfigure.	DO BCO
2.1.1.5 Monitor Navigation Center Failure	Remote monitor xmits through SDMS. Processor recommends alternate actions.	Monitor alarm. Select option from menu.	BCO
2.1.1.5.1 Receive Alarm Notification	Failure displayed with option menu.	Monitor failure. Select option. Notify SCO and DO.	BCO
2.1.1.5.2 Perform Indicator/Maneuver Test	Display planes/rudder angles and course/depth rate.	Select manual mode, move control. Observe change. Judge failure.	DO SCO
2.1.1.6 Monitor Battery Failure	Battery room hydrogen sensor tied to SDMS.	Infrequent backup inspection by roving monitor.	FWD AUX. ELEC.
2.1.1.6.1 Test Battery Room Hydrogen Level	Sense hydrogen level. Xmit level. Compare with limits. Provide alarm.	Observe alarm. Dispatch repair team. Notify OOD.	BCO

ASCOP FUNCTIONAL ALLOCATION TABLE

FUNCTION: 2.1 Maintain Ships Safety (continued)		CREW SIZE: 3	
Subfunction and Equipment	Equipment Process	Operator Task	Position
2.1.1.7 Monitor SDMS Failure	Detect failure. Xmit alarms plus options.	Monitor alarm. Select menu. Select option.	
2.1.1.7.1 Detect Failure	Detect failure. Alert operator. Provide options.	Monitor alarm. Select menu. Select option.	BCO
2.1.1.8 Monitor Collision		Collision functions are all operator functions.	
2.1.1.8.1 Sense Collision	Dedicated collision alarm	Observe collision. Sound general collision alarm if ordered.	BCO
2.1.1.8.2 Observe Collision Situation	Dedicated collision alarm.	Receive collision report from Conn. Sound general collision alarm.	BCO
2.1.1.8.3 Sense Torpedo Attack	Dedicated collision alarm.	Receive torpedo report from sonar. Sound general collision alarm if ordered.	BCO
2.1.1.8.4 Sense Sonar Signal Close Aboard	Dedicated collision alarm.	Receive collision report from sonar. Sound collision alarm if ordered.	BCO
2.1.1.9 Monitor Automatic Ship Control Failure	Automatic failure sensing and alarm.	Monitor and control	
2.1.1.9.1 Sense Failure	Sense failure. Display alarm and options.	Monitor alarm. Select option. Steer manually.	DO SCO

ASCOF FUNCTIONAL ALLOCATION TABLE

FUNCTION: 2.1 Maintain Ships Safety (continued)		CREW SIZE: 3	
Subfunction and Equipment	Equipment Process	Operator Task	Position
2.1.2 Detect Critical Failure			
2.1.2.1 Lose Reactor Power	Auto detection.	Note alarm, report to steersmen, reconfigure steering.	D0
2.1.2.2 Stern Plane Jam (High Speed)	Display normal SP indications. Display backup SP indications.	Observe differences, decide meter/stern plane. Report jam.	SP0
2.1.2.3 Flooding (Critical Locations)	Remote sensors tied to bilge level. Xmit canned message via SDMS.	Monitor bilge level changes. Send casualty team.	BC0
2.1.2.4 Fire (Critical Location)	Remote sensors tied to SDMS provide automatic alarm and location.	Monitor alarm. Send casualty team.	BC0
2.1.2.5 Lose Electrical Power (ship-wide)	Automatic power switching	Not local capability	
2.1.2.6 Collision	See 2.1.1.8.		
2.1.2.7 Lose Depth Sensing	Sensor detects failure.	Monitor failure. Report failure.	D0
2.1.2.8 Lose Major SCS Subsystem	BITE detects failures. SDMS interface	Monitor failure. Recon-figure as required.	D0

ASCOF FUNCTIONAL ALLOCATION TABLE
(continued)

FUNCTION: Subfunction and Equipment	2.1 Maintain Ships Safety (continued)	Equipment Process	CREW SIZE: 3 Operator Task	Position
2.1.3 Detect Critical System Failure Trend				
2.1.3.1 Lose Reactor Power (High Speed Dive)			Not local capability	
2.1.3.2 Stern Plane Jam (High Speed)			Not local capability	
2.1.3.3 Flooding (Critical Locations)	Store and display change in bilges as function of time. Display graph.		Monitor trend. Estimate impact.	DO
2.1.3.4 Fire (Critical Location)			Receive inspection reports of unsafe areas.	BCO
2.1.3.5 Lose Electrical Power (ship-wide)			Not local capability	
2.1.3.6 Collision			DNA	
2.1.3.7 Lose Depth Sensing			DNA	
2.1.3.8 Lose Major SCS Subsystem	Perform BITE trend analysis, where available.		Monitor trend data.	BCO

ASCOP FUNCTIONAL ALLOCATION TABLE

FUNCTION: 2.1 Maintain Ships Safety (continued)	Equipment Process	CREW SIZE: 3 Operator Task	Position
Subfunction and Equipment			
2.1.3.9 Lose Oxygen		Not local capability	

ASCOP FUNCTIONAL ALLOCATION TABLE

FUNCTION: 2.1 Maintain Ships Safety (continued)		CREW SIZE: 3	
Subfunction and Equipment	Equipment Process	Operator Task	Position
2.1.4 Identify Failed System(s)			
2.1.4.1 Lose Reactor Power (High-Speed Dive)	Auto-identification	DNA	
2.1.4.2 Sternplane Jam (High Speed)		Identify meter, hyd. or mech.	SPO
2.1.4.3 Flooding (Critical Location)	Identify, xmit, display flooding location and rate.	Monitor displayed location. Dispatch casualty team.	BCO
2.1.4.4 Fire (Critical Location)	Remote sensors tied to SDMS. Xmit location, type, alarm	Monitor location, type, alarm. Dispatch casualty team.	BCO
2.1.4.5 Lose Electrical Power (Ship-wide)	Automatic detection and switching.	Not local capability	
2.1.4.6 Collision	See 2.1.1.8		
2.1.4.7 Lose Depth Sensing	Sensor identifies failure. Xmit alarm. Display options	Monitor alarm. Call Maintenance.	BCO
2.1.4.8 Lose Major SCS Subsystem	Subsystem BITE detects, identifies failure, xmits, displays.	Monitor alarm. Report, reconfigure as required.	D0

ASCOP FUNCTIONAL ALLOCATION TABLE

FUNCTION: 2.1 Maintain Ships Safety (continued) Subfunction and Equipment	Equipment Process	CREW SIZE: 3 Operator Task	Position
2.1.5 Identify Failing System(s)			
2.1.5.1 Analyze Predicted Failure	DNA		
2.1.5.2 Identify Potential System/ Subsystem Failure	DNA		

AD-A062 740

ROCKWELL INTERNATIONAL ANAHEIM CA AUTONETICS MARINE --ETC F/6 17/2
ADVANCED SUBMARINE CONTROL PROGRAM. (U)
OCT 78

N00024-78-C-5308

UNCLASSIFIED

C78-1091/301

NL

3 OF 4

AD
A062740



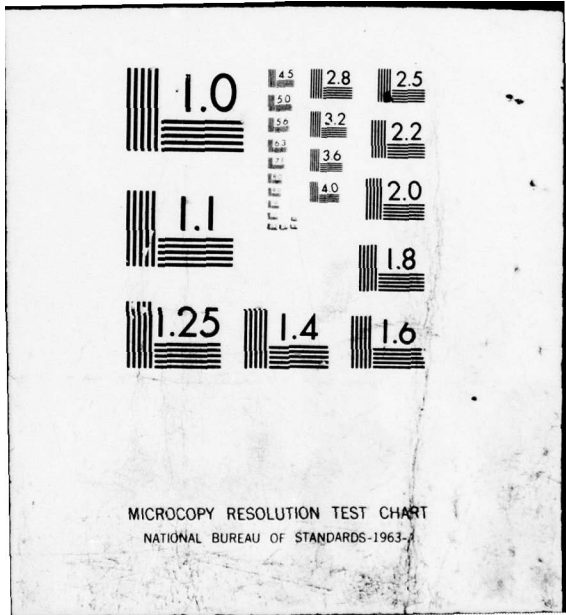

ASCOP FUNCTIONAL ALLOCATION TABLE

FUNCTION: 2.1 Maintain Ships Safety (continued)		CREW SIZE: 3	
Subfunction and Equipment	Equipment Process	Operator Task	Position
2.1.6 Take Appropriate Action			
2.1.6.1 Determine Impact of System/ Subsystem Degradation	Determine impact from pre-categorized alternatives.	Determine impact where not pre-determined.	
2.1.6.1.1 Analyze Impact	Determine impact for predetermined casualties.	Determine impact. Monitor impact.	DO BCO OOD
2.1.6.2 Take Necessary Action	For predetermined situations, display options, recommend options.	For non-predetermined failure, determine options; select options; initiate action.	
2.1.6.2.1 Modify Operating Plan	Recommend modification, if available.	Modify plan, if required.	OOD DO BCO
2.1.6.2.2 Reconfigure Operating Mode	Recommend options and best choice, where available	Change mode, if required.	DO BCO
2.1.6.2.3 Report Failure to Authority	Display failure, where available	Report failure, if required.	DO BCO SCO
2.1.6.2.4 Dispatch Casualty Repair Team		Dispatch casualty repair team, if required.	BCO
2.1.6.2.5 Shift Ballast	Recommend ballast shift and sequence.	Initiate ballast shift, if required.	BCO

ASCOF FUNCTIONAL ALLOCATION TABLE

FUNCTION: 2.1 Maintain Ships Safety (continued) Subfunction and Equipment	Equipment Process	Operator Task	CREW SIZE: 3 Position
2.1.6.2.6 Sound Alarm	Auto alarm, if available.	Sound alarm, if required.	BCO
2.1.6.2.7 Receive Data (Reports)	Xmit canned reports via SDMS, display on request.	Receive data reports; enter if required.	BCO

ASCOP FUNCTIONAL ALLOCATION TABLE

FUNCTION: 2.3 Perform Submerged Ship Control		CREW SIZE: 3	
Subfunction and Equipment	Equipment Process	Operator Task	Position
2.3.1 Perform Primary Ship Control Functions			
2.3.1.1 Perform Depth Control	Normal operating mode is automatic control.	Manual mode is backup	
2.3.1.1.1 Determine Ordered Depth and Accuracy	No direct input of commanded depth from conn.	Enter commanded depth and accuracy.	
2.3.1.1.1.1 Receive Verbal Command		Receive ordered depth and accuracy from conn.	D0
2.3.1.1.1.2 Convert Command to Appropriate Form		Enter ordered depth and accuracy on integrated C/P.	D0
2.3.1.1.2 Determine Actual Depth and Error			
2.3.1.1.2.1 Sense Depth	Automatic depth sensing, display corrected depth.	Monitor depth	SC0
2.3.1.1.2.2 Compare Ordered and Actual Depth	Compare actual and ordered depth.		
2.3.1.1.2.3 Determine Depth Error	Determine depth error.		

ASCOP FUNCTIONAL ALLOCATION TABLE

FUNCTION: 2.3 Perform Submerged Ship Control		CREW SIZE: 3	
Subfunction and Equipment	Equipment Process	Operator Task	Position
2.3.1.1.3 Determine Ship Response Characteristics	Compute ship response characteristics.	Provide data for ship response characteristics, order computation.	D0
2.3.1.1.3.1 Determine Ship Hydrodynamics	Store ship hydrodynamics	Determine ship hydrodynamics. Enter.	D0
2.3.1.1.3.2 Determine Water Conditions	Store water conditions.	Determine water conditions from sonar. Enter.	D0
2.3.1.1.3.3 Determine Ship's Speed	Determine speed. Display.	Read ship's speed.	D0
2.3.1.1.3.4 Determine Ship's Buoyancy and Trim	Compute buoyancy and trim estimate. Display.	Order buoyancy and trim estimate.	D0
2.3.1.1.4 Adjust Planes to Change Depth	Automatic depth control	Backup manual control	
2.3.1.1.4.1 Decide Which Planes to Use		Decide planes to use. Select mode.	D0
2.3.1.1.4.2 Decide/Set Plane Angle Limit		Decide/set plane angle limit.	D0
2.3.1.1.4.3 Decide/Set Pitch Angle Limit		Decide/set pitch angle limit.	D0

ASCOF FUNCTIONAL ALLOCATION TABLE

FUNCTION: 2.3 Perform Submerged Ship Control (Continued)		CREW SIZE: 3	
Subfunction and Equipment	Equipment Process	Operator Task	Position
2.3.1.1.4.4 Decide/Set Depth Rate		Decide/set depth rate.	D0
2.3.1.1.4.5 Move Planes to Required Angle	Move planes to required angle. Display.	Monitor planes action	SC0
2.3.1.1.4.6 Predict Time to End Maneuver	Predict time to end maneuver.		
2.3.1.1.4.7 Move Planes to End Maneuver	Move planes to end maneuver.	Monitor planes action.	SC0
2.3.1.1.6 Adjust Trim/Buoyancy for Ordered Depth	Calculate trim/buoyancy solution.	Manual data entry and initiation.	
2.3.1.1.6.1 Determine Water Density	Use data to calculate solution.	Order calculation.	D0
2.3.1.1.6.1.1 Read Sound Velocity Profile	Use data to calculate solution.	Enter SVP data.	D0
2.3.1.1.6.1.2 Read Temperature Charts	Use data to calculate solution.	Enter temperature data.	D0
2.3.1.1.6.2 Determine Past Water Conditions	Calculate water conditions	Order calculation	D0

ASCOP FUNCTIONAL ALLOCATION TABLE

FUNCTION: 2.3 Perform Submerged Ship Subfunction and Equipment	Control (continued)	CREW SIZE: 3	Position
	Equipment Process	Operator Task	
2.3.1.1.6.2.1 Read Diving Log	Use data to calculate solution.	Enter data from diving log.	D0
2.3.1.1.6.2.2 Read Past Sound Velocity Profiles	Use data to calculate solution.	Enter SVP data.	D0
2.3.1.1.6.2.3 Read NAVSAT Data	Use data to calculate solution.	Enter NAVSAT data analysis results.	D0
2.3.1.1.6.3 Determine Ship Buoyancy and Trim	Automatic calculation of trim and buoyancy.	Enter data, as required.	D0
2.3.1.1.6.3.1 Determine Planes Activity	Monitor and perform trend analysis of planes activity. Display	Monitor trend data.	D0
2.3.1.1.6.3.2 Determine Ship's Activities	Calculate ship buoyancy and trim.	Enter ship's activities.	D0
2.3.1.1.6.4 Determine Desired Buoyancy			
2.3.1.1.6.4.1 Consult Tables	Call up table, use to decide desirable buoyancy. Display	Enter sea state	D0
2.3.1.1.6.4.2 Receive Ordered Buoyancy		Enter ordered buoyancy.	D0

ASCOP FUNCTIONAL ALLOCATION TABLE

FUNCTION: 2.3 Perform Submerged Ship Control (continued)		CREW SIZE: 3	Position
Subfunction and Equipment	Equipment Process	Operator Task	
2.3.1.1.6.5 Determine Desired Trim	Display desired trim.	Enter desired trim.	D0
2.3.1.1.6.5.1 Receive Ordered Trim		Monitor desired trim.	BC0
2.3.1.1.6.6 Determine Water Movement	Provide recommended water movement based on available data.	Specify how much to be moved from where to where.	D0
2.3.1.1.6.6.1 Determine Acceptable Ship's Noise Level	Use to calculate water movement.	Receive acceptable ship's noise level from conn. Enter.	D0
2.3.1.1.6.6.2 Determine Acceptable Water Transfer Time	Use to calculate water movement.	Receive water transfer time from conn. Enter.	D0
2.3.1.1.6.6.4 Determine Water Tank Status	Determine water tank status. Use to calculate water movement. Display.	Monitor recommended water movement.	D0
2.3.1.1.6.7 Move Water	Water movement automatic.	Order water destination and quantity.	D0
2.3.1.1.6.7.1 Flood	Automatic sequencing	Monitor sequencing.	
2.3.1.1.6.7.1.1 Select Destination		Order destination and quantity. Enter.	D0

ASCOP FUNCTIONAL ALLOCATION TABLE

FUNCTION: 2.3 Perform Submerged Ship Control (continued)		CREW SIZE: 3	
Subfunction and Equipment	Equipment Process	Operator Task	Position
2.3.1.1.6.7.1.2 Open Hull and Backup Valves	Automatic sequence. Display	Monitor sequence.	BCO
2.3.1.1.6.7.1.3 Monitor Flood Rate	Monitor flood rate and display.	Monitor flood rate by exception.	BCO
2.3.1.1.6.7.1.4 Close Hull & Backup Valves & Destination Valves	Automatic sequence. Display	Monitor sequence.	BCO
2.3.1.1.6.7.2 Pump to Sea	Automatic sequencing	Monitor sequencing.	
2.3.1.1.6.7.2.1 Select Trim or Drain Pump	Automatic step, display	Monitor sequence.	BCO
2.3.1.1.6.7.2.2 Start Prime Pump	Automatic step, display	Monitor sequence.	BCO
2.3.1.1.6.7.2.3 Monitor Pressure & Suction	Monitor pressure and suction, display.	Monitor pressure and suction by exception.	BCO
2.3.1.1.6.7.2.4 Open Source Valve	Automatic step, display	Monitor sequence.	BCO
2.3.1.1.6.7.2.5 Start Main Pump	Automatic step, display	Monitor sequence.	BCO

ASCOF FUNCTIONAL ALLOCATION TABLE

FUNCTION: 2.3 Perform Submerged Ship Control (continued)		CREW SIZE: 3		
Subfunction and Equipment	Ship Control	Equipment Process	Operator Task	
			Position	
2.3.1.1.6.7.2.6	Monitor Pump Speed and Current	Monitor pump speed/current. Display.	Monitor pump speed and current by exception.	BCO
2.3.1.1.6.7.2.7	Open Destination Valve	Automatic step, display.	Monitor sequence.	BCO
2.3.1.1.6.7.2.8	Monitor Water Valve	Monitor water valve. Display.	Monitor water valve.	BCO
2.3.1.1.6.7.2.9	Close Destination Valve	Automatic step, display	Monitor destination valve.	BCO
2.3.1.1.6.7.2.10	Stop Pump	Automatic step, display	Monitor pump.	BCO
2.3.1.1.6.7.2.11	Close Source Valve	Automatic step, display	Monitor source valve, verify water transfer.	BCO
2.3.1.1.6.7.3	Pump Tank to Tank	Same as 2.3.1.1.6.7.2		
2.3.1.1.7	Adjust Trim/Buoyancy to Maintain Low Speed Depth	Automatic sequence	Manual monitor	
2.3.1.1.7.1	Determine Depth Rate and Acceleration	Monitor depth rate and acceleration. Display.	Monitor depth rate and acceleration by exception.	BCO

ASCOP FUNCTIONAL ALLOCATION TABLE
Control (continued)

FUNCTION: 2.3 Perform Submerged Ship Control (continued)		CREW SIZE: 3	
Subfunction and Equipment	Equipment Process	Operator Task	Position
2.3.1.8 Adjust Planes to Maintain Ordered High Speed Depth	Adjust planes, as required.	Monitor planes activity.	
2.3.1.2 Perform Course Control	Automatic control	Operator monitors and intervenes, where required.	SCO
2.3.1.2.1 Determine Ordered Course and Accuracy			
2.3.1.2.1.1 Receive Verbal Order from Conn	Use ordered course to compute maneuver.	Receive ordered course from conn. Enter course and accuracy.	DO
2.3.1.2.2 Determine Actual Course	Sense/calculate actual course. Display.	Monitor actual course.	CONN
2.3.1.2.2.1 Sense Gyro Output	Sense gyro output. Use to calculate course.		
2.3.1.2.3 Determine Ship Response Characteristics	Same as 2.3.1.1.3		
2.3.1.2.4 Adjust Rudder to Change Course	Adjust rudder to change course.	Monitor rudder change.	SCO
2.3.1.2.4.1 Determine/Set Roll		Determine/set roll limit	DO

ASCOF FUNCTIONAL ALLOCATION TABLE

FUNCTION: Subfunction and Equipment	2.3 Perform Submerged Ship Control (continued)	CREW SIZE: 3		
		Equipment Process	Operator Task	
2.3.1.2.4.2 Determine/Set Rudder Limit			Determine/set rudder limit.	D0
2.3.1.2.4.3 Determine Rudder Angle Required	Determine rudder angle required.			
2.3.1.2.4.4 Set Required Rudder Angle	Set required rudder angle. Display.		Monitor rudder angle.	SC0
2.3.1.2.4.5 Predict Time to End Maneuver	Predict time to end maneuver.			
2.3.1.2.4.6 Move Rudder to End Maneuver	Move rudder to end maneuver.		Monitor rudder	SC0
2.3.1.2.5 Adjust Rudder to Maintain Course	Adjust rudder to maintain course.		Monitor rudder movement.	SC0
2.3.1.2.5.1 Determine Yaw Acceleration	Determine yaw acceleration, use in rudder calculation.			

ASOP FUNCTIONAL ALLOCATION TABLE
Control (continued)

FUNCTION: 2.3 Perform Submerged Ship Control (continued)	Equipment Process	Operator Task	Position
Subfunction and Equipment 2.3.1.3 Perform Speed Control		Primarily manual function	
2.3.1.3.1 Determine Ordered Speed	Assist in determining alternate methods for speed control	Receive ordered speed. Enter	
2.3.1.3.1.1 Receive Verbal Orders		Receive ordered speed from comm. Enter	D0
2.3.1.3.2 Determine Actual Speed	Determine actual speed		
2.3.1.3.2.1 Sense Speed	Sense speed. Display	Monitor speed	D0
2.3.1.3.3 Determine Propulsion Change Required	Compute change required	Enter ordered speed	D0
2.3.1.3.3.1 Determine Direction and Size of Error	Compare actual and ordered speed. Compute error.		
2.3.1.3.3.2 Determine Change in RPM Required	Compute change in RPM required to achieve ordered speed. Display	Monitor RPM required	D0
2.3.1.3.3.3 Determine Change in Percent Propulsion Required	Compute change in percent propulsion required to achieve required speed	Monitor percent propulsion required	D0

ASCOP FUNCTIONAL ALLOCATION TABLE

FUNCTION: 2.3 Perform Submerged Ship Control (continued)		CREW SIZE: 3	Position
Subfunction and Equipment	Equipment Process	Operator Task	
2.3.1.3.4 Change Propulsion to Change Speed		Engine room operator controls speed	
2.3.1.3.4.1 Order Percent Propulsion Change	Engine order telegraph or intercommunication set	Order percent propulsion change	D0
2.3.1.3.4.2 Order RPM Change	Intercommunication set	Order RPM change	D0
2.3.1.3.4.3 Receive Percent Propulsion Change Acknowledgement	Engine order telegraph or intercommunication set	Receive percent propulsion change acknowledgement	D0
2.3.1.3.4.4 Receive RPM Change Acknowledgement	Intercommunication set	Receive RPM change acknowledgement	D0
2.3.1.3.5 Change Propulsion to Maintain Speed	Same as 2.3.1.3.4		

ASCOP FUNCTIONAL ALLOCATION TABLE

FUNCTION: 2.3 Perform Submerged Ship Control (continued)		CREW SIZE: 3	
Subfunction and Equipment	Equipment Process	Operator Task	Position
2.3.2 Monitor Ship Control Systems			
2.3.2.1 Monitor and Control Hydraulics	Automatic sequencing	Manual initiation and manual backup	
2.3.2.1.1 Monitor External Hydraulic Line Pressure	Sense/compare/display external hydraulic line pressure display	Monitor by exception	BCO
2.3.2.1.2 Monitor External Hydraulic Accumulator Quantity	Sense/compare/display external accumulator quantity	Monitor by exception	BCO
2.3.2.1.3 Monitor Port Hydraulic Line Pressure	Sense/compare/display port line pressure	Monitor by exception	BCO
2.3.2.1.4 Monitor Port Hydraulic Accumulator Quantity	Sense/compare/display port accumulator quantity	Monitor by exception	BCO
2.3.2.1.5 Monitor Lead Hydraulic Line Pressure	Sense/compare/display lead line pressure	Monitor by exception	BCO
2.3.2.1.6 Monitor Lead Hydraulic Accumulator Quantity	Sense/compare/display lead accumulator quantity	Monitor by exception	BCO
2.3.2.1.7 Monitor Starboard Hydraulic Line Pressure	Sense/compare/display starboard line pressure	Monitor by exception	BCO

ASCOP FUNCTIONAL ALLOCATION TABLE

FUNCTION: 2.3 Perform Submerged Ship Control (continued)		CREW SIZE: 3	
Subfunction and Equipment	Equipment Process	Operator Task	Position
2.3.2.1.8 Monitor Starboard Hydraulic Accumulator Quantity	Sense/compare/display starboard accumulator quantity	Monitor by exception	BCO
2.3.2.1.9 Monitor Steering and Diving Hydraulic Line Pressure	Sense/compare/display steering and diving line pressure	Monitor by exception	BCO
2.3.2.1.10 Monitor Steering and Diving Hydraulic Accumulator #1 Quantity	Sense/compare/display S&D accumulator #1 quantity	Monitor by exception	BCO
2.3.2.1.11 Monitor Steering and Diving Hydraulic Accumulator #2 Quantity	Sense/compare/display S&D accumulator #2 quantity	Monitor by exception	BCO
2.3.2.1.12 Monitor and Control External Pump #1 Status	Sense/compare/control/display external pump #1 status	Monitor by exception	BCO
2.3.2.1.13 Monitor and Control External Pump #2 Status	Sense/compare/control/display external pump #2 status	Monitor by exception	BCO
2.3.2.1.14 Monitor and Control Port Pump Status	Sense/compare/control/display port pump status	Monitor by exception	BCO
2.3.2.1.15 Monitor and Control Lead Pump Status	Sense/compare/control/display lead pump status	Monitor by exception	BCO
2.3.2.1.16 Monitor and Control Starboard Pump Status	Sense/compare/control/display pump status	Monitor by exception	BCO

ASCOP FUNCTIONAL ALLOCATION TABLE

FUNCTION: 2.3 Perform Submerged Ship Control (Continued)		CREW SIZE: 3	
Subfunction and Equipment	Equipment Process	Operator Task	Position
2.3.2.1.17 Monitor and Control S&D Pump #1 Status	Sense/compare/control/display S&D pump #1 status	Monitor by exception	BC0
2.3.2.1.18 Monitor and Control S&D Pump #2 Status	Sense/compare/control/display S&D pump #2 status	Monitor by exception	BC0
2.3.2.1.19 Monitor Stored Energy	Sense/compare/display stored energy	Monitor by exception	BC0
2.3.2.1.20 Monitor Hydraulic System Status	Sense/display hydraulic system status	Monitor hydraulic system status	BC0
2.3.2.2 Monitor and Control Hull Openings	Sense status, compare with mode, sound alarm when incompatible	Operator sets/disables rig for dive mode.	BC0
2.3.2.2.1 Monitor Aft Escape Hatch	Sense/display AFT escape hatch status, Sound alarm, if required.	Monitor AFT escape hatch status during dive.	BC0
2.3.2.2.2 Monitor Bridge Access	Sense/display bridge access status. Sound alarm, if required.	Monitor bridge access status during dive.	BC0
2.3.2.2.3 Monitor Forward Escape Hatch	Sense/display forward escape hatch status. Sound alarm, if required.	Monitor forward escape hatch status during dive.	BC0
2.3.2.2.4 Monitor WPN Shipping Hatch	Sense/display WPN shipping hatch status. Sound alarm, if required.	Monitor WPN shipping hatch status during dive.	BC0

ASCOP FUNCTIONAL ALLOCATION TABLE

FUNCTION: 2.3 Perform Submerged Ship Control (continued)		CREW SIZE: 3	
Subfunction and Equipment	Equipment Process	Operator Task	Position
2.3.2.2.5 Monitor and Control Hover Backup Valve	Sense/display hover backup valve status. Open/close valve. Sound alarm, if required.	Monitor valve status during	BCO
2.3.2.2.6 Monitor and Control Hover Hull Valve	Sense/display hover hull valve status. Open/close valve. Sound alarm, if required.	Monitor valve status during dive. Switch valve open/close	SCO
2.3.2.2.7 Monitor and Control Trim Backup Valve	Sense/display trim backup valve status. Open/close valve. Sound alarm, if required.	Monitor trim backup valve during dive. Switch valve open/close	BCO
2.3.2.2.8 Monitor and Control Trim Hull Valve	Sense/display trim hull valve status. Open/close valve. Sound alarm, if required.	Monitor trim hull valve during dive. Switch valve open/close	BCO
2.3.2.2.9 Monitor Induction Backup Valve	Sense/display induction backup valve status. Sound alarm, if required.	Monitor induction backup valve status during dive.	BCO
2.3.2.2.10 Monitor and Control Induction Hull Valve	Sense/display induction hull valve status. Open/close valve. Sound alarm, if required.	Monitor induction hull valve during dive. Switch open/close.	BCO
2.3.2.2.11 Monitor Exhaust Backup Valve	Sense/display exhaust backup valve status. Sound alarm, if required.	Monitor exhaust backup valve status during dive.	BCO
2.3.2.2.12 Monitor and Control Exhaust Hull Valve		Manual function.	
2.3.2.3 Monitor Water Tight Compartments			

ASCOP FUNCTIONAL ALLOCATION TABLE

FUNCTION: 2.3 Perform Submerged Ship Subfunction and Equipment	Control (continued) Equipment Process	CREW SIZE: 3 Operator Task	Position
2.3.2.3.1 Receive Verbal Forward Compartment Status		Receive verbal report on forward compartment status	BCO
2.3.2.3.2 Receive Verbal Aft Compartment Status		Receive verbal report on aft compartment status	BCO
2.3.2.4 Monitor Hydrogen Concentration		Manual function	
2.3.2.4.1 Sense Hydrogen Concentration	Sense/display hydrogen concentration in battery room	Monitor/xmit hydrogen concentration	Fwd Aux elect.
2.3.2.4.2 Receive Reports of Hydrogen Concentration		Receive report of hydrogen concentration	BCOP
2.3.2.5 Monitor and Control Air Pressure Systems	Monitor and display status. Out-of- tolerance conditions trigger alarm	Monitor by exception. Initiate control.	BCO
2.3.2.5.1 Monitor 700 PSIG Air Pressure	Sense/display 700 PIGA air pressure. Sound alarm if required.	Monitor by exception	BCO
2.3.2.5.2 Monitor 4500 PSIG Air Pressure	Sense/display 4500 PIGA air pressure. Sound alarm if required.	Monitor by exception.	BCO
2.3.2.5.3 Monitor/Control High Pressure Air Bank #1	Sense/display HP air bank #1. Control on/off line. Sound alarm, if required.	Monitor by exception. Switch on/off line.	BCO

ASCOP FUNCTIONAL ALLOCATION TABLE

FUNCTION: 2.3 Perform Submerged Ship		CREW SIZE: 3	
Subfunction and Equipment	Control (continued)	Operator Task	Position
	Equipment Process		
2.3.2.5.4 Monitor/Control High Pressure Air Bank #2	Sense/display HP air bank #2. Control on/off line. Sound alarm, if required.	Monitor by exception. Switch on/off line.	BCO
2.3.2.5.5 Monitor/Control High Pressure Air Bank #3	Sense/display HP air bank #3. Control on/off line. Sound alarm, if required.	Monitor by exception. Switch on/off line.	BCO
2.3.2.5.6 Monitor/Control High Pressure Air Bank #4	Sense/display HP air bank #4. Control on/off line. Sound alarm, if required.	Monitor by exception. Switch on/off line.	BCO
2.3.2.5.7 Monitor/Control High Pressure Air Bank #5	Sense/display HP air bank #5. Control on/off line. Sound alarm, if required.	Monitor by exception. Switch on/off line.	BCO
2.3.2.6 Monitor and Control SCS Electric System	Automatic switch to safe position, then to emergency power	Manual override, if required.	BCO
2.3.2.6.1 Monitor and Control Normal/Emergency Stern Plane Power	Sense/display stern plane power status. Control normal/emergency.	Monitor by exception. Switch normal/emergency.	BCO
2.3.2.6.2 Monitor and Control Normal/Emergency Fairwater Plane Power	Sense/display fairwater plane power status. Control normal/emergency.	Monitor by exception. Switch normal/emergency.	BCO
2.3.2.6.3 Monitor and Control Normal/Emergency Rudder Power	Sense/display rudder power status. Control normal/emergency.	Monitor by exception. Switch normal/emergency.	BCO
2.3.2.6.4 Monitor and Control SCS Power	Sense/display SCS power status. Control on/off	Monitor SCS power status. Switch on/off.	BCO

ASCOP FUNCTIONAL ALLOCATION TABLE

FUNCTION: 2.3 Perform Submerged Ship Control (continued)		CREW SIZE: 3	Position
Subfunction and Equipment	Equipment Process	Operator Task	
2.3.2.6.5 Monitor and Control Critical Circuit Power	Sense/display critical circuit power status. Control on/off.	Monitor critical circuit power status. Switch on/off.	BCO
2.3.2.7 Monitor and Control Processor	Automatic monitoring failure detection. Recommend reconfiguration.	Manual selection of reconfiguration option	BCO
2.3.2.7.1 Recognize Failure	Monitor/recognize failure display alarm and options	Monitor failure	BCO
2.3.2.7.2 Select Backup Mode (Reconfigure)	Recommend reconfiguration option.	Select reconfiguration option.	BCO
2.3.2.8 Monitor and Control Masts/Antenna		Manual function	
2.3.2.8.1 Monitor Periscopes and Shrouds	Sense/display periscope shroud status	Monitor periscope/shroud status	BCO
2.3.2.8.2 Monitor and Control Navigation Light	Sense/display navigation light status. Raise/lower navigation light.	Monitor navigation light status. Switch raise/lower	BCO
2.3.2.8.3 Monitor and Control Multi-Purpose Masts 1 & 2	Sense/display multipurpose masts 1 & 2 status. Raise/lower masts.	Monitor multipurpose masts 1 & 2 status switch Raise/lower	BCO
2.3.2.8.4 Monitor and Control RDF Mast	Sense/display RDF mast status. Raise/lower RDF mast.	Monitor RDF mast. Switch raise/lower	BCO

ASCOP FUNCTIONAL ALLOCATION TABLE

FUNCTION: 2.3 Perform Submerged Ship Control (continued)		CREW SIZE: 3	
Subfunction and Equipment	Equipment Process	Operator Task	Position
2.3.2.8.6 Monitor and Control Induction Mast	Sense/display induction mast status. Raise/lower induction mast.	Monitor induction mast. Switch raise/lower	BCO
2.3.2.8.7 Monitor and Control Head Valve	Sense/display head valve status. Open/close head valve	Monitor head valve status. Switch open/close.	BCO
2.3.2.8.8 Monitor and Control Heaters	Sense/display heaters status. Turn heaters on/off.	Monitor heaters status. Switch on/off.	BCO
2.3.2.8.9 Monitor and Control Electrode Test	Sense/display electrode test status. Start/end test.	Monitor electrode test status. Switch start/end test.	BCO
2.3.2.8.10 Monitor and Control Towed Array	Sense/display critical circuit power status. Turn power on/off	Monitor optical circuit power status. Switch on/off.	BCO
2.3.2.9 Monitor and Control Console Controls and Displays		Manual function	
2.3.2.9.1 Monitor Console Indicators	Periodically test console indicator circuits. Display alarm, if required.	Monitor indicators by exception	BCO
2.3.2.9.2 Adjust CRT Controls		Adjust CRT controls to achieve desired contrast and brightness	SCO
2.3.2.9.3 Adjust Plasma Display Controls		Adjust plasma control to achieve desired brightness	SCO DO BCO

ASCOP FUNCTIONAL ALLOCATION TABLE

FUNCTION: 2.3 Perform Submerged Ship Control (continued)		CREW SIZE: 3	
Subfunction and Equipment	Equipment Process	Operator Task	Position
2.3.2.9.4 Adjust Panel Brightness	Adjust panel brightness relative to ambient illumination.	Override automatic panel adjustment, as required.	SCO DO BCO
2.3.2.10 Monitor and Control SDMS			
2.3.2.10.1 Recognize Failure	Detect failure. Display alarm	Monitor SDMS by exception	BCO
2.3.2.10.2 Reconfigure SDMS	Automatically reconfigure. Display new configuration.	Monitor new configuration Override, as required.	BCO
2.3.2.11 Monitor and Control MBT Vents and Emergency Blow Valves			
2.3.2.11.1 Monitor and Control MBT Vents	Sense/display MBT vents status. Open/close MBT vents.	Monitor MBT vents status. Switch vents. Open/close	BCO
2.3.2.11.2 Monitor Emergency Blow Valves	Sense/display emergency blow valve status. Open/shut valves.	Monitor emergency blow valve status. Switch open/close.	BCO
2.3.2.12 Maintain SCS Log			
2.3.2.12.1 Maintain Log of Course Changes	Store & display course changes.	Enter course change data. Review & approve watch log.	DO

ASCOF FUNCTIONAL ALLOCATION TABLE

FUNCTION: 2.3 Perform Submerged Ship Control (continued) Subfunction and Equipment	Equipment Process	CREW SIZE: 3 Operator Task	Position
2.3.3 Perform Watch Supervisor Functions			
2.3.3.1 Supervise Forward Auxiliarmen		Supervise Forward Auxiliarmen	BCO
2.3.3.2 Supervise Auxiliary Electrician Forward		Supervise Auxiliary Electrician Forward	BCO
2.3.3.3 Supervise Lee Helm and Ship Control Operator		Supervise Lee Helm, if available, and Ship Control Operator	BCO
2.3.3.4 Perform Phone Talker Duties	Xmit canned messages via SDMS & display	Perform phone talker duties. Select & receive canned messages.	BCO

ASCOPE FUNCTIONAL ALLOCATION TABLE

FUNCTION: 2.4 Perform External Communications		CREW SIZE: 3	
Subfunction and Equipment	Equipment Process	Operator Task	Position
2.4.1 Ascent to Communication/ Periscope Depth			
2.4.2 Deploy Periscope		Manual function	
2.4.2.1 Verify Periscope Depth		Verify ship at periscope depth	000
2.4.2.2 Activate Periscope Drive	Sense/display periscope status. Activate periscope drive.	Monitor periscope status	BC0
2.4.2.3 Sense Periscope Fully Extended	Sense periscope fully extended. Display.	Monitor periscope fully extended	BC0
2.4.2.4 Deactivate Periscope Drive	Deactivate periscope drive. Display periscope status.	DNA	

ASCOP FUNCTIONAL ALLOCATION TABLE

FUNCTION: 2.5 Perform Scheduled/Unscheduled Maintenance	Subfunction and Equipment	Equipment Process	CREW SIZE: 3 Operator Task	Position
2.5.1 Perform Scheduled Maintenance				
2.5.1.1 Determine Scheduled Maintenance Task			Not SCS Function	
2.5.2 Perform Unscheduled Maintenance			Not SCS Function	
2.5.2.1 Determine Unscheduled Maintenance Task			Not SCS Function	

ASCOP FUNCTIONAL ALLOCATION TABLE

FUNCTION: 2.6 Perform Modified Submerged Ship Control		CREW SIZE: 3	
Subfunction and Equipment	Equipment Process	Operator Task	Position
2.6.1 Perform Modified Primary Ship Control			
2.6.1.1 Operate with Manual Stern-planes Control		Perform stern plane steering manually. (Backup mode)	SCO
2.6.1.2 Operate with Manual Fair-water Planes Control		Perform fairwater planes steering manually (Backup mode)	SCO
2.6.1.3 Operate with Manual Rudder Control		Perform rudder control manually (Backup mode)	SCO
2.6.1.4 Operate with Manual Planes/Rudder Control	Integrate control commands to provide best signals to each control surface.	Perform simultaneous stern/planes, fairwater plane and rudder manually (Backup mode)	SCO
2.6.1.5 Operate with Emergency Sternplanes Power		Perform stern plane steering under emergency power.	SCO
2.6.1.6 Operate with Emergency Fairwater Planes Power		Perform fairwater plane steering under emergency power.	BCO
2.6.1.7 Operate with Emergency Rudder Power		Perform rudder plane steering under emergency power.	DO
2.6.1.8 Operate with Backup Planes/Rudder Control		Perform simultaneous emergency steering control	SCO BCO DO

ASCOP FUNCTIONAL ALLOCATION TABLE

FUNCTION: 2.6 Perform Modified Submerged Ship Control (continued)	Equipment Process	CREW SIZE: 3 Operator Task	Position
Subfunction and Equipment			
2.6.2 Perform Modified Secondary Ship Control			
2.6.2.1 Operate Trim and Buoyancy Backup System			Remote
2.6.2.2 Operate Hydraulic Backup System			Remote
2.6.2.3 Operate Masts/Antenna Backup System			DNA
2.6.2.4 Operate Water Tight Backup System			Remote
2.6.2.5 Operate Air Pressure Backup System			Remote

C78-109/301

APPENDIX D

TWO-MAN CREW FUNCTIONAL ALLOCATION TABLE

ASCOP FUNCTIONAL ALLOCATION TABLE

FUNCTION: 2.1 Maintain Ships Safety (cont) Subfunction and Equipment	Equipment Process	CREW SIZE: 2 Operator Task	Position
2.1.4 Identify Failed System(s)			
2.1.4.1 Stern Plane Jam (High Speed Dive)	Automatic identification	DNA	
2.1.4.2 Stern Plane Jam (High Speed)	Identify whether meter, hydraulics or mechanical	Evaluate identification	SP0
2.1.4.3 Flooding (Critical Locations)	Identify, xmit, display flooding location and rate	Monitor by exception	BC0
2.1.4.4 Fire (Critical Location)	Identify, xmit, display fire location, type, and alarm	Monitor by exception	BC0
2.1.4.5 Lose Electrical Power	Automatic identification and switching	Not local responsibility	
2.1.4.6 Collision	See 2.1.1.8		
2.1.4.7 Lose Depth Sensing	Sensor identifies failure, xmits alarm, displays options	Monitor identity, change mode, if required	BC0
2.1.4.8 Lose Major SCS Subsystem	BITE identifies failed system. Xmit and display identity.	Monitor by exception	BC0

ASCOP FUNCTIONAL ALLOCATION TABLE

FUNCTION: 2.1 Maintain Ships Safety (continued) Subfunction and Equipment	Equipment Process	CREW SIZE: 2 Operator Task	Position
2.1.5 Identify Failing System(s)	VOID		
2.1.5.1 Analyze Predicted Failure			
2.1.5.2 Identify Potential System/ Subsystem Failure			

ASCOF FUNCTIONAL ALLOCATION TABLE

FUNCTION: 2.1 Maintain Ships Safety (continued)		CREW SIZE: 2	
Subfunction and Equipment	Equipment Process	Operator Task	Position
2.1.6 Take Appropriate Action			
2.1.6.1 Determine Impact of System/ Subsystem Degradation			
2.1.6.1.1 Analyze Impact	Analyze impact of predetermined casualties. Display	Analyze impact for non- predetermined casualties	SCO BCO
2.1.6.2 Take Necessary Action	Automatic action, where available, display status and options.	Monitor status, actions and options, override if required	SCO BCO
2.1.6.2.1 Modify Operating Plan	Modify operating plan, where possible. Display actions, options, procedures.	Monitor by exception, select option, follow procedure.	SCO BCO OOD
2.1.6.2.2 Reconfigure Operating Mode	Reconfigure operating mode, display action options.	Monitor by exception. Over- ride, as required.	SCO BCO
2.1.6.2.3 Report Failure to Authority	Display failure to all operators. Display details, as required.	Monitor failures. Request details.	SCO ECO OOD
2.1.6.2.4 Dispatch Casualty Repair Team	Transmit casualty repair team canned messages over SDMS. Display.	Dispatch casualty repair team. Monitor progress.	BCO
2.1.6.2.5 Shift Ballast	Determine required ballast shift. Auto- matically shift ballast. Display status.	Monitor by exception.	BCO

ASCOF FUNCTIONAL ALLOCATION TABLE

FUNCTION: 2.3 Perform Submerged Ship Control		CREW SIZE: 2	
Subfunction and Equipment	Equipment: Process	Operator Task	Position
2.3.1 Perform Primary Ship Control Functions			
2.3.1.1 Perform Depth Control			
2.3.1.1.1 Determine Ordered Depth and Accuracy	No direct input from conn.	Enter both depth and accuracy.	
2.3.1.1.1.1 Receive Verbal Command		Receive ordered depth and accuracy from conn.	SCO
2.3.1.1.1.2 Convert Command to Appropriate Form	Receive, store, operate on entered depth and accuracy.	Enter ordered depth and accuracy.	SCO
2.3.1.1.2 Determine Actual Depth and Error			
2.3.1.1.2.1 Sense Depth	Automatic depth sensing. Display corrected depth.	Monitor depth.	SCO
2.3.1.1.2.2 Compare Ordered and Actual Depth	Compare ordered and actual depth.		
2.3.1.1.2.3 Determine Depth Error	Determine depth error.		

ASCOP FUNCTIONAL ALLOCATION TABLE

FUNCTION: 2.3 Perform Submerged Ship Control		CREW SIZE: 2		Position
Subfunction and Equipment	Equipment Process	Operator Task		
2.3.1.1.3 Determine Ship Response Characteristics	Compute ship response characteristics from entered data.	Provide data for ship response calculations.		SCO
2.3.1.1.3.1 Determine Ship Hydrodynamics	Store ship hydrodynamics. Use for ship response calculations.	Determine ship hydrodynamics. Enter.		SCO
2.3.1.1.3.2 Determine Water Conditions	Receive water conditions from sonar via SDMS. Use for ship response calculations.			
2.3.1.1.3.3 Determine Ship's Speed	Determine ship's speed. Use for ship response calculations.			
2.3.1.1.3.4 Determine Ship's Buoyancy and Trim	Compute ship's buoyancy and trim. Display use for ship response calculations.	Monitor ship's buoyancy & trim. Override if required.		SCO
2.3.1.1.4 Adjust Planes to Change Depth	Automatic depth control (normal mode)	Backup manual depth control.		
2.3.1.1.4.1 Decide Which Planes to Use		Decide planes to use. Select mode.		SCO
2.3.1.1.4.2 Decide/Set Plane Angle Limit		Decide/set plane angle limit		SCO
2.3.1.1.4.3 Decide/Set Pitch Angle Limit		Decide/set pitch angle limit.		SCO

ASCOF FUNCTIONAL ALLOCATION TABLE

FUNCTION: 2.3 Perform Submerged Ship Control (Continued)	Equipment Process	CREW SIZE: 2 Operator Task	Position
Subfunction and Equipment			
2.3.1.1.4.4 Decide/Set Depth Rate		Decide/set depth rate	SCO
2.3.1.1.4.5 Move Planes to Required Angle	Move planes to required angle. Display.	Monitor planes action and depth.	SCO
2.3.1.1.4.6 Predict Time to End Maneuver	Predict time to end maneuver		
2.3.1.1.4.7 Move Planes to End Maneuver	Move planes to end maneuver	Monitor planes action and depth.	SCO
2.3.1.1.6 Adjust Trim/Buoyancy for Ordered Depth	Calculate and adjust trim/buoyancy	Monitor by exception. Manual backup.	BCO
2.3.1.1.6.1 Determine Water Density	Calculate water density. Use to calculate trim and buoyancy.		
2.3.1.1.6.1.1 Read Sound Velocity Profile	Receive SVP data from sonar processor via SDMS use to calculate water density		
2.3.1.1.6.1.2 Read Temperature Charts	Select data from stored temperature charts. Use to calculate water density.		
2.3.1.1.6.2 Determine Past Water Conditions	Select data from stored water condition, where available.	Input data on past water conditions where required.	BCO

ASCOPE FUNCTIONAL ALLOCATION TABLE

FUNCTION: Subfunction and Equipment	2.3 Perform Submerged Ship Control (continued)	Equipment Process	CREW SIZE: 2 Operator Task	Position
2.3.1.1.6.2.1	Read Diving Log	Select stored log data. Use to calculate water conditions.		
2.3.1.1.6.2.2	Read Past Sound Velocity Profiles	Select stored SVP data. Use to calculate water conditions.		
2.3.1.1.6.2.3	Read NAVSAT Data	Receive NAVSAT data via SDMS. Use to calculate water conditions.		
2.3.1.1.6.3	Determine Ship Buoyancy and Trim	Calculate ship's trim & buoyancy	Enter data, as required.	BCO
2.3.1.1.6.3.1	Determine Planes Activity	Monitor and perform trend analysis of planes activity. Display	Monitor planes activity	BCO
2.3.1.1.6.3.2	Determine Ship's Activities	Use data to calculate ship buoyancy and trim.	Enter ship's activities	BCO
2.3.1.1.6.4	Determine Desired Buoyancy			
2.3.1.1.6.4.1	Consult Tables	Call up stored tables. Use for determining desired buoyancy.	Enter sea state.	BCO
2.3.1.1.6.4.2	Receive Ordered Buoyancy	Receive ordered buoyancy. Use to calculate desired buoyancy.	Enter ordered buoyancy.	BCO

ASCOPE FUNCTIONAL ALLOCATION TABLE

FUNCTION: 2.3 Perform Submerged Ship Control (continued)	Equipment Process	CREW SIZE: 2 Operator Task	Position
Subfunction and Equipment	Equipment Process	Operator Task	Position
2.3.1.1.6.5 Determine Desired Trim	Calculate desired trim.		
2.3.1.1.6.5.1 Receive Ordered Trim	Receive ordered trim. Use to calculate desired trim.	Enter ordered trim.	
2.3.1.1.6.6 Determine Water Movement	Calculate water movement.		
2.3.1.1.6.6.1 Determine Acceptable Ship's Noise Level	Use data to calculate water movement.	Enter acceptable noise level received from conn.	BCO
2.3.1.1.6.6.2 Determine Acceptable Water Transfer Time	Use data to calculate water movement.	Enter acceptable water transfer time from conn.	BCO
2.3.1.1.6.6.4 Determine Water Tank Status	Sense water tank status. Use to calculate water movement.	Monitor scheduled water movement.	BCO
2.3.1.1.6.7 Move Water	Water movement automatic	Monitor by exception. Manual backup available.	BCO
2.3.1.1.6.7.1 Flood	Automatic sequencing	Monitor by exception	BCO
2.3.1.1.6.7.1.1 Select Destination	Select destination and quantity. Display	Monitor by exception.	BCO

ASCOPE FUNCTIONAL ALLOCATION TABLE

FUNCTION: 2.3 Perform Submerged Ship Control (continued)	CREW SIZE: 2	Position
Subfunction and Equipment	Equipment Process	Operator Task
2.3.1.1.6.7.1.2 Open Hull and Backup Valves	Open hull and backup valves. Display.	Monitor by exception BCO
2.3.1.1.6.7.1.3 Monitor Flood Rate	Monitor flood rate. Display	Monitor flood rate BCO
2.3.1.1.6.7.1.4 Close Hull & Backup Valves & Destination Valves	Close hull and backup valves and destination valve. Display	Monitor valve status & completion of sequence BCO
2.3.1.1.6.7.2 Pump to Sea	Automatic sequencing	
2.3.1.1.6.7.2.1 Select Trim or Drain Pump	Select pump display	Monitor by exception BCO
2.3.1.1.6.7.2.2 Start Prime Pump	Start prime pump. Display	Monitor by exception BCO
2.3.1.1.6.7.2.3 Monitor Pressure & Suction	Monitor pressure & suction. Display	Monitor by exception BCO
2.3.1.1.6.7.2.4 Open Source Valve	Open source valve. Display	Monitor by exception BCO
2.3.1.1.6.7.2.5 Start Main Pump	Start main pump. Display	Monitor by exception BCO

ASCOPE FUNCTIONAL ALLOCATION TABLE

FUNCTION: 2.3 Perform Submerged Ship Control (continued)	Subfunction and Equipment	Equipment Process	CREW SIZE: 2 Operator Task	Position
2.3.1.1.6.7.2.6	Monitor Pump Speed and Current	Monitor pump speed and current. Display	Monitor pump speed and current	BCO
2.3.1.1.6.7.2.7	Open Destination Valve	Open destination valve. Display	Monitor by exception	BCO
2.3.1.1.6.7.2.8	Monitor Water Valve	Monitor water valve. Display	Monitor water valve.	BCO
2.3.1.1.6.7.2.9	Close Destination Valve	Close destination valve. Display	Monitor by exception	BCO
2.3.1.1.6.7.2.10	Stop Pump	Stop pump. Display	Monitor by exception	BCO
2.3.1.1.6.7.2.11	Close Source Valve	Close source valve. Display	Monitor completion of sequence	BCO
2.3.1.1.6.7.3	Pump Tank to Tank	Same as 2.3.1.1.6.7.2		
2.3.1.1.7	Adjust Trim/Buoyancy to Maintain Low Speed Depth	Automatic Sequence	Manual backup available	BCO
2.3.1.1.7.1	Determine Depth Rate and Acceleration	Sense/calculate depth rate and acceleration display.	Monitor by exception	BCO

ASCOPE FUNCTIONAL ALLOCATION TABLE

FUNCTION: 2.3 Perform Submerged Ship Control (continued)		CREW SIZE: 2	
Subfunction and Equipment	Equipment Process	Operator Task	Position
2.3.1.1.7.1 Determine Depth Rate and Acceleration	Sense/calculate depth rate and acceleration. Display	Monitor by exception	BCO
2.3.1.1.8 Adjust Planes to Maintain Ordered High Speed Depth	Adjust planes, as required.	Monitor plane's activity.	BCO
2.3.1.2 Perform Course Control	Automatic control	Operator monitors course and intervenes, where required.	SCO
2.3.1.2.1 Determine Ordered Course and Accuracy			
2.3.1.2.1.1 Receive Verbal Order from Conn	Use ordered course to compute maneuver.	Receive verbal order from conn. Enter course & accuracy.	SCO
2.3.1.2.2 Determine Actual Course	Sense/calculate actual course. Display.	Monitor actual course.	SCO CONN
2.3.1.2.2.1 Sense Gyro Output	Sense gyro output. Use to calculate actual course.		
2.3.1.2.3 Determine Ship Response Characteristics	Same as 2.3.1.1.3		
2.3.1.2.4 Adjust Rudder to Change Course	Adjust rudder to change course.	Monitor course change	SCO

ASCOF FUNCTIONAL ALLOCATION TABLE
Control (continued)

FUNCTION: 2.3 Perform Submerged Ship Control (continued)	Equipment Process	CREW SIZE: 2 Operator Task	Position
Subfunction and Equipment 2.3.1.2.4.1 Determine/Set Roll Limit		Determine/Set Roll Limit	SCO
2.3.1.2.4.2 Determine/Set Rudder Limit		Determine/Set Rudder Limit	SCO
2.3.1.2.4.3 Determine Rudder Angle Required	Determine rudder angle required.		
2.3.1.2.4.4 Set Required Rudder Angle	Set required rudder angle display.	Monitor by exception	SCO
2.3.1.2.4.5 Predict Time To End Maneuver	Predict time to end maneuver		
2.3.1.2.4.6 Move Rudder to End Maneuver	Move rudder to end maneuver	Monitor course	SCO
2.3.1.2.5 Adjust Rudder to Maintain Course	Adjust rudder to maintain course	Monitor course	SCO
2.3.1.2.5.1 Determine Yaw Acceleration	Determine yaw acceleration. Use in rudder calculation.		
2.3.1.2.5.2 Move Rudder to End Correction Maneuver	Move rudder to end correction.	Monitor course. Override as required.	SCO

ASOP FUNCTIONAL ALLOCATION TABLE

FUNCTION: 2.3 Perform Submerged Ship Control (continued)		CREW SIZE: 2	
Subfunction and Equipment	Equipment Process	Operator Task	Position
2.3.1.3 Perform Speed Control	Automatic calculation, transmission of speed change.	Enter required speed change. Monitor by exception.	
2.3.1.3.1 Determine Ordered Speed		Manual input.	SCO
2.3.1.3.1.1 Receive Verbal Orders		Receive ordered speed from conn.	SCO
2.3.1.3.2 Determine Actual Speed	Determine actual speed. Display	Monitor speed.	
2.3.1.3.2.1 Sense Speed	Sense speed. Use to calculate actual speed. Display	Monitor speed.	SCO
2.3.1.3.3 Determine Propulsion Change Required	Compute change required.		
2.3.1.3.3.1 Determine Direction and Size of Error	Determine direction and size of error.		
2.3.1.3.3.2 Determine Change in RPM Required	Calculate change in RPM required. Display.	Monitor change required.	SCO
2.3.1.3.3.3 Determine Change in Percent Propulsion Required	Calculate change in percent propulsion required. Display	Monitor change required.	SCO

ASCOF FUNCTIONAL ALLOCATION TABLE

FUNCTION: 2.3 Perform Submerged Ship Control (continued)		CREW SIZE: 2	Position
Subfunction and Equipment	Equipment Process	Operator Task	
2.3.1.3.4 Change Propulsion to Change Speed		Engine room operator controls speed	
2.3.1.3.4.1 Order Percent Propulsion Change	Transmit percent propulsion change order to engine room via SDMS. Display	Order percent propulsion change via overlay keyboard.	SCO
2.3.1.3.4.2 Order RPM Change	Transmit RPM change order to engine room via SDMS. Display	Order RPM change via overlay keyboard.	SCO
2.3.1.3.4.3 Receive Percent Propulsion Change Acknowledgement	Receive engine room acknowledgement via SDMS. Display acknowledge or alarm.	Monitor acknowledgement or alarm.	SCO
2.3.1.3.4.4 Receive RPM Change Acknowledgement	Receive engine room acknowledgement via SDMS. Display acknowledge or alarm.	Monitor acknowledgement or alarm.	SCO
2.3.1.3.5 Change Propulsion to Maintain Speed	Same as 2.3.1.3.4		

ASCOF FUNCTIONAL ALLOCATION TABLE

FUNCTION: 2.3 Perform Submerged Ship Control (continued)		CREW SIZE: 2	Position
Subfunction and Equipment	Equipment Process	Operator Task	
2.3.2 Monitor Ship Control Systems			
2.3.2.1 Monitor and Control Hydraulics	Automatic sequencing	Monitor by exception. Manual backup switching available.	
2.3.2.1.1 Monitor External Hydraulic Line Pressure	Sense/compare/display external hydraulic line pressure. Display	Monitor by exception	BCO
2.3.2.1.2 Monitor External Hydraulic Accumulator Quantity	Sense/compare/display external accumulator quantity	Monitor by exception	BCO
2.3.2.1.3 Monitor Port Hydraulic Line Pressure	Sense/compare/display port line pressure	Monitor by exception	BCO
2.3.2.1.4 Monitor Port Hydraulic Accumulator Quantity	Sense/compare/display port accumulator quantity	Monitor by exception	BCO
2.3.2.1.5 Monitor Lead Hydraulic Line Pressure	Sense/compare/display lead line pressure.	Monitor by exception	BCO
2.3.2.1.6 Monitor Lead Hydraulic Accumulator Quantity	Sense/compare/display lead accumulator quantity	Monitor by exception	BCO
2.3.2.1.7 Monitor Starboard Hydraulic Line Pressure	Sense/compare/display starboard line pressure.	Monitor by exception	BCO

ASCOF FUNCTIONAL ALLOCATION TABLE

FUNCTION: 2.3 Perform Submerged Ship Control (continued)		CREW SIZE: 2	
Subfunction and Equipment	Equipment Process	Operator Task	Position
2.3.2.1.8 Monitor Starboard Hydraulic Accumulator Quantity	Sense/compare/display starboard accumulator quantity	Monitor by exception	BCO
2.3.2.1.9 Monitor Steering and Diving Hydraulic Line Pressure	Sense/compare/display S&D line pressure	Monitor by exception	BCO
2.3.2.1.10 Monitor Steering and Diving Hydraulic Accumulator #1 Quantity	Sense/compare/display S&D accumulator #1 quantity	Monitor by exception	BCO
2.3.2.1.11 Monitor Steering and Diving Hydraulic Accumulator #2 Quantity	Sense/compare/display S&D accumulator #2 quantity	Monitor by exception	BCO
2.3.2.1.12 Monitor and Control External Pump #1 Status	Sense/compare/display/control external pump #1 status	Monitor by exception	BCO
2.3.2.1.13 Monitor and Control External Pump #2 Status	Sense/compare/control/display external pump #2 status.	Monitor by exception	BCO
2.3.2.1.14 Monitor and Control Port Pump Status	Sense/compare/control/display port pump status	Monitor by exception	BCO
2.3.2.1.15 Monitor and Control Lead Pump Status	Sense/compare/control/display lead pump status.	Monitor by exception	BCO
2.3.2.1.16 Monitor and Control Starboard Pump Status	Sense/compare/control/display. Starboard pump status.	Monitor by exception	BCO

ASCOP FUNCTIONAL ALLOCATION TABLE

FUNCTION: 2.3 Perform Submerged Ship Control (Continued)		CREW SIZE: 2	Position
Subfunction and Equipment	Equipment Process	Operator Task	
2.3.2.1.17 Monitor and Control S&D Pump #1 Status	Sense/compare/control/display S&D pump #1 status.	Monitor by exception	BCO
2.3.2.1.18 Monitor and Control S&D Pump #2 Status	Sense/compare/control/display S&D pump #2 status.	Monitor by exception	BCO
2.3.2.1.19 Monitor Stored Energy	Sense/compare/display stored energy.	Monitor by exception.	BCO
2.3.2.1.20 Monitor Hydraulic System Status	Sense/display hydraulic system status.	Monitor by exception	BCO
2.3.2.2 Monitor and Control Hull Openings	Sense status, compare with mode, sound alarm, when required.	Monitor by exception. Manual backup switching available.	BCO
2.3.2.2.1 Monitor Aft Escape Hatch	Sense/display aft except hatch status. Sound alarm, if required.	Monitor by exception.	BCO
2.3.2.2.2 Monitor Bridge Access	Sense/display bridge access status. Sound alarm, if required.	Monitor by exception.	BCO
2.3.2.2.3 Monitor Forward Escape Hatch	Sense/display fwd escape hatch status. Sound alarm, if required.	Monitor by exception	BCO
2.3.2.2.4 Monitor WPN Ship	Sense/display weapon ship hatch status. Sound alarm, if required.	Monitor by exception.	BCO

ASCOP FUNCTIONAL ALLOCATION TABLE

FUNCTION: 2.3 Perform Submerged Ship Control (continued)		CREW SIZE: 2	
Subfunction and Equipment	Equipment Process	Operator Task	Position
2.3.2.2.5 Monitor and Control Hover Backup Valve	Sense/display hover backup valve status. Open/close valve. Sound alarm, if required.	Monitor by exception	BCO
2.3.2.2.6 Monitor and Control Hover Hull Valve	Sense/display hover hull valve status. Open/close valve. Sound alarm, if required.	Monitor by exception	BCO
2.3.2.2.7 Monitor and Control Trim Backup Valve	Sense/display trim backup valve status. Open/close valve. Sound alarm, if required.	Monitor by exception	BCO
2.3.2.2.8 Monitor and Control Trim Hull Valve	Sense/display trim hull valve. Open/close valve. Sound alarm, if required.	Monitor by exception	BCO
2.3.2.2.9 Monitor Induction Backup Valve	Sense/display induction backup valve status. Sound alarm, if required.	Monitor by exception	BCO
2.3.2.2.10 Monitor and Control Induction Hull Valve	Sense/display induction hull valve status. Open/close valve. Sound alarm, if required.	Monitor by exception	BCO
2.3.2.2.11 Monitor Exhaust Backup Valve	Sense/display exhaust backup valve status. Sound alarm, if required.	Monitor by exception	BCO
2.3.2.2.12 Monitor and Control Exhaust Hull Valve	Sense/display exhaust hull valve status. Open/close valve. Sound alarm, if required.	Monitor by exception	BCO
2.3.2.3 Monitor Water Tight Compartments	Automatic sensing of compartment status sent to SCS via SDMS.	Monitor by exception	BCO

ASUCOP FUNCTIONAL ALLOCATION TABLE

FUNCTION: 2.3 Perform Submerged Ship Control (continued)		CREW SIZE: 2	
Subfunction and Equipment	Equipment Process	Operator Task	Position
2.3.2.3.1 Receive Verbal Forward Compartment Status	DNA	DNA	
2.3.2.3.2 Receive Verbal Aft Compartment Status	DNA	DNA	
2.3.2.4 Monitor Hydrogen Concentration	Automatic sensing and transmission to SCS via SDMS.	Monitor by exception	
2.3.2.4.1 Sense Hydrogen Concentration	Sense/compare/display hydrogen concentration. Sound alarm, if required.	Monitor by exception	BCO
2.3.2.4.2 Receive Reports of Hydrogen Concentration		DNA	
2.3.2.5 Monitor and Control Air Pressure Systems	Monitor and control air pressure system status. Sound alarm, if required.	Monitor by exception. Backup control available.	BCO
2.3.2.5.1 Monitor 700 PSIG Air Pressure	Sense/display 700 psig air pressure. Sound alarm, if required.	Monitor by exception	BCO
2.3.2.5.2 Monitor 4500 PSIG Air Pressure	Sense/display 4500 psig air pressure. Sound alarm, if required.	Monitor by exception	BCO
2.3.2.5.3 Monitor/Control High Pressure Air Bank #1	Sense/display HP airbank #1. Sound alarm, if required.	Monitor by exception	BCO

ASCOP FUNCTIONAL ALLOCATION TABLE

FUNCTION: Subfunction and Equipment	Control (continued)	CREW SIZE: Operator Task	Position
2.3.2.5.4 Monitor/Control High Pressure Air Bank #2	Sense/display HP air bank #2. Sound alarm, if required.	Monitor by exception.	BCO
2.3.2.5.5 Monitor/Control High Pressure Air Bank #3	Sense/display HP air bank #3. Sound alarm, if required.	Monitor by exception	BCO
2.3.2.5.6 Monitor/Control High Pressure Air Bank #4	Sense/display HP air bank #4. Sound alarm, if required.	Monitor by exception	BCO
2.3.2.5.7 Monitor/Control High Pressure Air Bank #5	Sense/display HP air bank #5. Sound alarm, if required.	Monitor by exception	BCO
2.3.2.6 Monitor and Control SCS Electric System	Automatic switching to safe position, then emergency power.	Manual override, if required.	BCO
2.3.2.6.1 Monitor and Control Normal/Emergency Stern Plane Power	Sense/display sternplane power status. Normal/emergency	Monitor by exception	SCO
2.3.2.6.2 Monitor and Control Normal/Emergency Fairwater Plane Power	Sense/display fairwater planes power status. Set normal/emergency	Monitor by exception	SCO
2.3.2.6.3 Monitor and Control Normal/Emergency Rudder Power	Sense/display rudder power status. Set normal/emergency.	Monitor by exception	SCO
2.3.2.6.4 Monitor and Control SCS Power	Sense/display SCS power status. Control on/off.	Monitor SCS power status. Switch on/off.	BCO

ASCOP FUNCTIONAL ALLOCATION TABLE

FUNCTION: 2.3 Perform Submerged Ship Control (continued)		CREW SIZE: 2	
Subfunction and Equipment	Equipment Process	Operator Task	Position
2.3.2.6.5 Monitor and Control Critical Circuit Power	Sense/display critical circuit power status. Control on/off.	Monitor critical circuit power status. Switch on/off	BCO
2.3.2.7 Monitor and Control Processor	Automatic monitoring, failure detection and reconfiguration.	Monitor by exception	BCO
2.3.2.7.1 Recognize Failure	Monitor/recognize failure. Display	Monitor by exception	BCO
2.3.2.7.2 Select Backup Mode (Reconfigure)	Select backup mode	Monitor by exception	BCO
2.3.2.8 Monitor and Control Masts/Antenna		Manual function	
2.3.2.8.1 Monitor Periscopes and Shrouds	Sense/display periscope/shroud	Monitor periscope/shroud status.	BCO
2.3.2.8.2 Monitor and Control Navigation Light	Sense/display navigation light status. Raise/lower mast.	Monitor navigation light status. Switch raise/lower.	BCO
2.3.2.8.3 Monitor and Control Multi-Purpose Masts 1 & 2	Sense/display multipurpose masts 1 & 2 status. Raise/lower masts.	Monitor multipurpose masts 1 and 2 status. Switch raise/lower.	BCO
2.3.2.8.4 Monitor and Control RDF Mast	Sense/display RDF mast status. Raise/lower mast.	Monitor RDF mast status. Switch raise/lower.	BCO

ASCOP FUNCTIONAL ALLOCATION TABLE

FUNCTION: 2.3 Perform Submerged Ship Control (continued)		CREW SIZE: 2	
Subfunction and Equipment	Equipment Process	Operator Task	Position
2.3.2.8.6 Monitor and Control Induction Mast	Sense/display induction mast status. Raise/lower mast.	Monitor induction mast status. Switch raise/lower	BCO
2.3.2.8.7 Monitor and Control Head Valve	Sense/display head valve status. Open/close valve.	Monitor head valve status. Switch open/close.	BCO
2.3.2.8.8 Monitor and Control Heaters	Sense/display heater status. Turn on/off.	Monitor heater status. Switch on/off.	BCO
2.3.2.8.9 Monitor and Control Electrode Test	Sense/display electrode test status. Start/end test.	Monitor electrode test status. Switch start/end test.	BCO
2.3.2.8.10 Monitor and Control Towed Array	Sense/display towed array status. Deploy/retract array. Cut cable.	Monitor towed array status. Switch deploy/retract. Switch cable cut.	BCO
2.3.2.9 Monitor and Control Console Controls and Displays		Manual function.	
2.3.2.9.1 Monitor Console Indicators	Bite test console indicator circuits. Display alarm, if required.	Monitor by exception	BCO
2.3.2.9.2 Adjust CRT Controls		Adjust CRT controls to achieve desired contrast and brightness	SCO BCO
2.3.2.9.3 Adjust Plasma Display Controls		Adjust plasma controls to achieve desired brightness.	SCO BCO

ASCOF FUNCTIONAL ALLOCATION TABLE

FUNCTION: 2.3 Perform Submerged Ship Control (continued)		CREW SIZE: 2	
Subfunction and Equipment	Equipment Process	Operator Task	Position
2.3.2.9.4 Adjust Panel Brightness	Adjust panel brightness relative to ambient illumination	Override auto adjustment, as required.	SCO BCO
2.3.2.10 Monitor and Control SDMS			
2.3.2.10.1 Recognize Failure	Detect failure. Display alarm.	Monitor SDMS, by exception	BCO
2.3.2.10.2 Reconfigure SDMS	Reconfigure. Display new configuration.	Monitor new configuration. Override as required.	BCO
2.3.2.11 Monitor and Control MBT Vents and Emergency Blow Valves			
2.3.2.11.1 Monitor and Control MBT Vents	Sense/Display MBT vents status. Open/close vents.	Monitor MBT vents status. Switch open/close.	BCO
2.3.2.11.2 Monitor and Control Emergency Blow Valves	Sense/display emergency blow valve status.	Monitor emergency blow valve status.	BCO
2.3.2.12 Maintain SCS Log	Automatic log keeping		
2.3.2.12.1 Maintain Log of Course Changes	Store & display course changes. Print out log.	Review and approve watch log.	SCO

ASCOP FUNCTIONAL ALLOCATION TABLE

FUNCTION: 2.3 Perform Submerged Ship Subfunction and Equipment	Control (continued)	CREW SIZE: 2 Operator Task	Position
	Equipment Process		
2.3.2.12.2 Maintain Log of Depth Changes	Store and display depth changes. Print out log.	Review and approve watch log	SCO
2.3.2.12.3 Maintain Log of Speed Changes	Store and display speed changes. Print out log.	Review and approve watch log	SCO
2.3.2.12.4 Maintain Log of Casualties	Store and display casualty data	Review and approve watch log	BCO
2.3.2.12.5 Maintain Log of Operating Modes	Store and display operating modes. Print out logs	Review and approve watch log	BCO

ASCOF FUNCTIONAL ALLOCATION TABLE

FUNCTION: 2.3 Perform Submerged Ship Control (continued)	Equipment Process	CREW SIZE: 2 Operator Task	Position
Subfunction and Equipment			
2.3.3 Perform Match Supervisor Functions			
2.3.3.1 Supervise Forward Auxiliaries		Supervise FWD auxiliaries	BCO
2.3.3.2 Supervise Auxiliary Electrician Forward		Supervise auxiliary electrician FWD	BCO
2.3.3.4 Perform Phone Talker Duties	Transmit canned messages via SDMS and display	Perform phone talker duties. Select & receive canned messages.	BCO
2.3.3.5 Operate IMC Circuit		Operate IMC circuit	BCO

ASCOP FUNCTIONAL ALLOCATION TABLE

FUNCTION: 2.4 Perform External Communications		CREW SIZE: 2	Position
Subfunction and Equipment	Equipment Process	Operator Task	
2.4.1 Ascent to Communication/ Periscope Depth			
2.4.2 Deploy Periscope		Manual function	
2.4.2.1 Verify Periscope Depth		Verify ship at periscope depth	OOD
2.4.2.2 Activate Periscope Drive	Sense/display periscope status. Activate periscope drive.	Monitor periscope status	BCO
2.4.2.3 Sense Periscope Fully Extended	Sense periscope fully extended. Display	Monitor periscope fully extended	BCO
2.4.2.4 Deactivate Periscope Drive	Deactivate periscope drive. Display periscope status.	DNA	

ASCOP FUNCTIONAL ALLOCATION TABLE

FUNCTION: 2.5 Perform Scheduled/Unscheduled Maintenance Subfunction and Equipment	Equipment Process	CREW SIZE: 2 Operator Task	Position
2.5.1 Perform Scheduled Maintenance			
2.5.1.1 Determine Scheduled Maintenance Task		Not SCS function	
2.5.2 Perform Unscheduled Maintenance		Not SCS function	
2.5.2.1 Determine Unscheduled Maintenance Task		Not SCS function	

ASCOP FUNCTIONAL ALLOCATION TABLE

FUNCTION: 2.6 Perform Modified Submerged Ship Control		CREW SIZE: 2	
Subfunction and Equipment	Equipment Process	Operator Task	Position
2.6.1 Perform Modified Primary Ship Control			
2.6.1.1 Operate with Manual Stern-planes Control		Perform sternplane steering manually (backup mode)	SCO
2.6.1.2 Operate with Manual Fair-water Planes Control		Perform fairwater plane steering manually (backup mode)	SCO
2.6.1.3 Operate with Manual Rudder Control		Perform rudder control manually (backup mode)	SCO
2.6.1.4 Operate with Manual Planes/Rudder Control	Integrate control commands to provide best signals to each control surface.	Perform simultaneous sternplane/fairwater/rudder steering manually (backup mode)	BCO
2.6.1.5 Operate with Emergency Sternplanes Power		Perform sternplane steering under emergency power	SCO
2.6.1.6 Operate with Emergency Fairwater Planes Power		Perform fairwater planes steering under emergency power	BCO
2.6.1.7 Operate with Emergency Rudder Power		Perform rudder steering under emergency power	BCO
2.6.1.8 Operate with Backup Planes/Rudder Control		Perform simultaneous emergency steering	SCO BCO

ASCOP FUNCTIONAL ALLOCATION TABLE

FUNCTION: 2.6 Perform Modified Submerged Ship Control (continued) Subfunction and Equipment	Equipment Process	CREW SIZE: 2 Operator Task	Position
2.6.1.9 Operate with After Steering Control			Remote

ASCOF FUNCTIONAL ALLOCATION TABLE

FUNCTION: 2.6 Perform Modified Submerged Ship Control (continued)	Equipment/Process	CREW SIZE: 2	Operator Task	Position
2.6.2 Perform Modified Secondary Ship Control				
2.6.2.1 Operate Trim and Buoyancy Backup System				Remote
2.6.2.2 Operate Hydraulic Backup System				Remote
2.6.2.3 Operate Masts/Antenna Backup System				DNA
2.6.2.4 Operate Water Tight Backup System				Remote
2.6.2.5 Operate Air Pressure Backup System				Remote

ASCOP FUNCTIONAL ALLOCATION TABLE

FUNCTION: 2.1 Maintain Ships Safety	CREW SIZE: 2		
Subfunction and Equipment	Equipment Process	Operator Task	Position
2.1.1 Monitor Critical Functions			
2.1.1.1 Monitor Planes/Rudder Failure	Automatic monitor and control of planes/rudder position to achieve ordered depth	Enters commanded depth, course, speed, maneuver limits.	SCO
2.1.1.1.1 Compare Commanded and Actual Planes/Rudder Response	Automatic comparison of actual and commanded planes/rudder position	Monitor maneuver performance Check performance quality.	SCO
2.1.1.1.2 Decide Response In/Out of Tolerance	Decides in/out of tolerance. Display alarm. Change mode as required. Display change.	Monitor by exception. Select detailed display. Select alternate option, if required.	SCO
2.1.1.2 Monitor Fire	Fire sensors tied to SDMS. Transmit alarm and location. Display status and operator procedure.	Monitor alarm. Select option. BCO	BCO
2.1.1.2.1 Detect Smoke	Smoke sensor or observer transmits alarm through SDMS. Display procedure, location and options. Automatic general alarm.	Monitor alarm. Dispatch casualty team by option selection from menu.	BCO OOD
2.1.1.2.2 Receive Fire Report	Fire sensor or observer transmits alarm through SDMS. Display procedure, location, options, auto general alarm.	Monitor alarm. Dispatch casualty team by option selection from menu.	BCO OOD
2.1.1.3 Monitor Flooding			
2.1.1.3.1 Sense Water Influx	Sensors send alarm directly through SDMS. Display location and flood rate. Automatic alarm.	Monitor display. Dispatch casualty team by option selection from menu	BCO

ASCOP FUNCTIONAL ALLOCATION TABLE

FUNCTION: 2.1 Maintain Ships Safety (continued)		CREW SIZE: 2	
Subfunction and Equipment	Equipment Process	Operator Task	Position
2.1.1.3.2 Observe Excess Water	Observer sends alarm through SDMS canned messages. Display location and estimate flood rate. Automatic alarm.	Monitor display. Dispatch casualty team by option selection from menu.	BCO
2.1.1.4 Monitor Power Failure	Automatic monitoring and reconfiguration.	Monitor by exception. Override, if required.	BCO
2.1.1.4.1 Sense Power Loss	Automatic sensing and reconfiguration	Monitor by exception. Override, if required, from menu.	BCO
2.1.1.4.2 Observe Open Fuse	DNA	DNA	
2.1.1.5 Monitor Navigation Center Failure	Remote monitor tied to SDMS. Display cause and recommended action. Reconfigured automatically.	Monitor alarm and reconfiguration. Override as required.	BCO
2.1.1.5.1 Receive Alarm Notification	Display failure. Automatic reconfiguration.	Monitor failure and reconfiguration. Override as required	BCO
2.1.1.5.2 Perform Indicator/Maneuver Test	Display planes/rudder angles and course/depth rate.	Select manual mode. Move ship control. Judge failure/normal.	SCO
2.1.1.6 Monitor Battery Failure	Battery room hydrogen sensor tied to SDMS.	Infrequent backup inspections by roving monitor.	Fwd. Aux. Elec.
2.1.1.6.1 Test Battery Room Hydrogen Level	Sense hydrogen level. Transmit level. Compare with limits. Display alarm.	Monitor alarm. Dispatch casualty team by canned message. Alert OOD.	BCO

ASCOP FUNCTIONAL ALLOCATION TABLE

FUNCTION: 2.1 Maintain Ships Safety (continued)		CREW SIZE: 2	
Subfunction and Equipment	Equipment Process	Operator Task	Position
2.1.1.7 Monitor SDMS Failure	Automatic detection and reconfiguration	Monitor by exception	
2.1.1.7.1 Detect Failure	Detect failure. Reconfigure display status and options.	Monitor by exception. Override by menu selection, if required.	BCO
2.1.1.8 Monitor Collision			
2.1.1.8.1 Sense Collision	Dedicated collision alarm.	Observe collision. Sound collision alarm, if required.	BCO
2.1.1.8.2 Observe Collision Situation	Dedicated collision alarm	Receive collision report from conn. Sound collision alarm.	BCO
2.1.1.8.3 Sense Torpedo Attack	Torpedo alert from sonar via SDMS. Automatic alarm.	Monitor alarm. Alert conn, if required.	BCO
2.1.1.8.4 Sense Sonar Signal Close Aboard	Collision report from sonar via SDMS. Automatic alarm.	Monitor alarm. Alert conn, if required.	BCO
2.1.1.9 Monitor Automatic Ship Control Failure			
2.1.1.9.1 Sense Failure	Sense failure. Automatic reconfiguration. Display action and options.	Monitor action. Override, if required. Steer manually.	SCO

ASCOP FUNCTIONAL ALLOCATION TABLE

FUNCTION: 2.1 Maintain Ships Safety (cont) Subfunction and Equipment	Equipment Process	CREW SIZE: 2 Operator Task	Position
2.1.2 Detect Critical Failure			
2.1.2.1 Lose Reactor Power (High Speed Dive)	Automatic detection and reconfiguration. Display alarm and operator procedure	Monitor alarm. Alert SCO. Reconfigure steering mode	BCO
2.1.2.2 Sternplane Jam (High Speed)	Display normal sternplane indications. Display backup SP indications. Reconfigure	Monitor. Reconfigure. Accept/reject solutions. Report jam. Take action if required	SP0
2.1.2.3 Flooding (Critical Locations)	Remote sensors tied to bilge level. Xmit canned message via SDMS. Automatic dispatch of casualty team.	Monitor by exception. Coordinate casualty team	BCO
2.1.2.4 Fire (Critical Location)	Remote sensors tied to bilge level. Xmit canned message via SDMS. Automatic dispatch of casualty team.	Monitor by exception. Coordinate casualty team	BCO
2.1.2.5 Lose Electrical Power (Shipwide)	Automatic power switching	Not local responsibility	
2.1.2.6 Collision	See 2.1.1.8		
2.1.2.7 Lose Depth Sensing	Sensor detects failure. Display failure and options/procedure	Monitor failure. Select option (change mode)	SP0
2.1.2.8 Lose Major SCS Subsystem	BITE detects failure. SDMS interface. Automatic reconfiguration	Monitor failure. Change mode if required	BCO

ASCOP FUNCTIONAL ALLOCATION TABLE

FUNCTION: 2.1 Maintain Ships Safety (cont.)		CREW SIZE: 2	
Subfunction and Equipment	Equipment Process	Operator Task	Position
2.1.3 Detect Critical System Failure Trend			
2.1.3.1 Lose Reactor Power (High Speed)		Not local responsibility	
2.1.3.2 Stereplane Jam (High Speed)		Not local responsibility	
2.1.3.3 Flooding (Critical Locations)	Store and display changes in bilge level as a function of time. Display alarm and graph	Monitor trend and alarm	BCO
2.1.3.4 Fire (Critical Location)	Store inspection history. Display on demand	Receive inspection reports of unsafe areas. Enter for storage.	BCO
2.1.3.5 Lose Electrical Power		Not local responsibility	
2.1.3.6 Collision		DNA	
2.1.3.7 Lose Depth Sensing		DNA	
2.1.3.8 Lose Major SCS Subsystem	Perform BITE trend analysis. Alert operator of limit approach	Monitor trend data. Alert maintenance	BCO

C78-109/301

APPENDIX E

INFORMATION REQUIREMENTS ANALYSIS

Functional Requirement: 2.1.1 MAINTAIN SHIP'S SAFETY

INFORMATION ITEM	TIME FORM			AVAILABILITY			CRITICALITY RATING			SAMPLING RATE			CREW ASSIGNMENT			MEASUREMENT UNIT	ERROR TOLERANCE	TYPE OF DISPLAY			
	LT STOR	ST STOR	PRES VALUE	PROJ VALUE	FAST	NORM	LOW	ALARM	LOW	CONT	4-MAN	3-MAN	2-MAN	4-MAN	3-MAN			2-MAN	4-MAN	3-MAN	2-MAN
2.1.1.2																					
Ship Architecture	X					X		X						BCPO	BCO	BCO			DNA	MFD	MFD
Critical Smoke Fire Locations	X					X		X						BCPO	BCO	BCO			DNA	MFD	MFD
Personnel Locations, Avail.						X		X						BCPO	BCO	BCO			DNA	MFD	MFD
General Alarm Bell						X		X						SHIP	SHIP	SHIP			AUDIO	AUDIO	AUDIO
Status Readout		X				X		X						DNA	BCO	BCO			DNA	MFD	MFD
Display Option Menu	X					X		X						DNA	BCO	BCO			DNA	MFD	MFD
2.1.1.3																					
Ship Architecture	X					X		X						BCPO	BCO	BCO			DNA	MFD	MFD
Critical Flood Locations	X					X		X						BCPO	BCO	BCO			DNA	MFD	MFD
Personnel Locations, Avail						X		X						BCPO	BCO	BCO			DNA	MFD	MFD
General Alarm Bell						X		X						SHIP	SHIP	SHIP			AUDIO	AUDIO	AUDIO
Status Readout		X				X		X						DNA	BCO	BCO			DNA	MFD	MFD
Display Option Menu	X					X		X						DNA	BCO	BCO			DNA	MFD	MFD

FUNCTIONAL REQUIREMENT: 2.1.1 (Cont'd)

INFORMATION ITEM	TIME FORM				AVAILABILITY			CRITICALITY RATING		SAMPLING RATE		CREW ASSIGNMENT			MEAS UNIT	ERROR TOLER	TYPE OF DISPLAY	
	LT STOR	ST STOR	PRES VALUE	PROJ VALUE	FAST	NORM	LOW	ALARM	LOW	CONT	4-MAN	3-MAN	2-MAN	4-MAN			3-MAN	2-MAN
2.1.1.4																		
Power Loss Indicator			X		X		X					BCPO	BCO	BCO		DED	MFD	
Blown Fuse Indicator			X		X			X				BCPO	BCO	BCO		DED	MFD	
Mode Options	X					X						BCPO	BCO	BCO		DED	MFD	
Display Option Menu	X					X						DNA	BCO	BCO		DNA	MFD	
Master Alarm			X				X					DNA	BCO	BCO		DNA	DED	
2.1.1.5																		
Mode Options	X				X		X					BCPO	BCO	BCO		DED	MFD	
Master Alarm			X		X		X					DNA	BCO	BCO		DNA	DED	
Display Option Menu	X					X		X				DNA	BCO	BCO		DNA	MFD	
Casualty Type			X			X		X				BCPO	BCO	BCO		DED	MFD	
SP Angle			X			X		X		X		SPO	SCO	SCO	DEG	.25°		
FWP Angle			X			X		X		X		FW/H	SCO	SCO	DEG	.5°		
Rudder Angle			X			X		X		X		FW/H	SCO	SCO	DEG	.1°		
Depth Rate			X			X		X		X		SPO	SCO	SCO	FT/SEC			
Course Rate			X			X		X		X		FW/H	SCO	SCO	DEG/SEC			

FUNCTIONAL REQUIREMENT: 2.1.2 DETECT CRITICAL FAILURE

INFORMATION ITEM	TIME FORM			AVAILABILITY			CRITICALITY RATING		SAMPLING RATE		CREW ASSIGNMENT			MEAS UNIT	ERROR TOLER	TYPE OF DISPLAY		
	LT STOR	ST STOR	PRES VALUE	PROJ VALUE	FAST	NORM	LOW	ALARM	LOW	CONT	4-MAN	3-MAN	2-MAN			4-MAN	3-MAN	2-MAN
2.1.2.1																		
Failure Alarm			X		X			X	X		DO	DO	BCO	-				
Master Alarm			X		X			X	X		DNA	DO	BCO	-			MFD DED	
Mode Options	X					X			X		DO	DO	BCO	-			MFD	
Display Option Menu	X					X			X		DNA	DO	BCO	-			MED	
2.1.2.2																		
Normal SP Angle			X		X					X	SPO	SCO	SCO				MFD	
Backup Sp Angle			X		X					X	SPO	SCO	SCO				MFD	
Failure Alarm Master Alarm			X		X			X	X		SPO	SCO	SCO				MFD	
General Alarm			X		X			X	X		DNA	SCO	SCO				DED DED	
2.1.2.3											SHIP	SHIP	SHIP				AUDIO AUDIO	
Bilge Level			X			X			X		DNA	DNA	BCO				DNA MFD	
Bilge Level Limits	X				X				X		DNA	DNA	BCO				DNA MFD	
Display Option Menu	X				X				X		DNA	BCO	BCO				DNA MFD	
Message Display	X				X				X		DNA	BCO	BCO				DNA MFD	

FUNCTIONAL REQUIREMENT: 2.3.1 PERFORM PRIMARY SHIP CONTROL FUNCTION(S)

INFORMATION ITEM	TIME FORM			AVAILABILITY		CRITICALITY RATING		SAMPLING RATE		CREW ASSIGNMENT			MEAS UNIT	ERROR TOLER	TYPE OF DISPLAY			
	LT STOR	ST STOR	PRES VALUE	PROJ VALUE	FAST	NORM	LOW	ALARM	LOW	CONT	4-MAN	3-MAN			2-MAN	4-MAN	3-MAN	2-MAN
2.3.1.1																		
Steering Mode Options	X					X	X		X		DO	DO	SCO		DED	MFD	MFD	
Commanded Depth		X				X	X		X		SPO FW/H	SCO	SCO	FT	.1	DED	MFD	
Actual Depth			X				X		X		SPO FW/H	SCO	SCO	FT	.1	DED	MFD	
Actual Speed			X			X	X		X		SPO FW/H	SCO	SCO	KNOTS	.1	DED	MFD	
Ships Buoyancy & Trim Tank Quantities			X			X	X		X		DO BCPO	BCO	BCO	-	DED	MFD	MFD	
Actual SP Position			X			X	X		X		DO	SCO	SCO	1bs	DED	MFD	MFD	
Actual FWP Position			X			X	X		X		SPO	SCO	SCO	DEG	.25°	DED	MFD	
Plant Angle Limit			X			X	X		X		FW/H	SCO	SCO	DEG	.5°	DED	MFD	
Pitch Angle Limit		X				X	X		X		DO	DO	SCO	DEG		DED	MFD	
Depth Rate		X				X	X		X		DO	DO	SCO	DEG		DED	MFD	
Commanded SP Angle		X				X	X		X		DNA	SCO	SCO	FT/SEC		DED	MFD	
Commanded FWP Angle		X				X	X		X		SPO	SCO	SCO	DEG	.1°	DED	MFD	
Recommended Water Transfer				X		X	X		X		FW/H	SCO	SCO	DEG	.1°	DED	MFD	
Actual Water Transfer			X			X	X		X		BCPO	BCO	BCO	GAL/MIN		DNA	MFD	
			X			X	X		X		BCPO	BCO	BCO	GAL/MIN		DED	MFD	

FUNCTIONAL REQUIREMENTS: 2.3.2 MONITOR SHIP CONTROL SYSTEMS

INFORMATION ITEM	TIME FORM			AVAILABILITY		CRITICALITY RATING		SAMPLING RATE		CREW ASSIGNMENT		MEAS UNIT	ERROR TOLER	TYPE OF DISPLAY				
	LT STOR	ST STOR	PRES VALUE	PROJ VALUE	FAST	NORM	LOW	ALARM	LOW	CONT	4-MAN			3-MAN	2-MAN	4-MAN	3-MAN	2-MAN
2.3.2.1																		
External Hydraulic Pressure			X			X		X			BCPO	BCO			DED	MFD	MFD	
Ext. Hyd.Accum Quantity			X			X		X			BCPO	BCO			DED	MFD	MFD	
Port Hydraulic Pressure			X			X		X			BCPO	BCO			DED	MFD	MFD	
Port. Hyd.Accum. Quantity			X			X		X			BCPO	BCO			DED	MFD	MFD	
Lead Hydraulic Pressure			X			X		X			BCPO	BCO			DED	MFD	MFD	
Lead Hyd.Accum. Quantity			X			X		X			BCPO	BCO			DED	MFD	MFD	
Stbd Hydraulic Pressure			X			X		X			BCPO	BCO			DED	MFD	MFD	
Stbd. Hyd.Accum. Quantity			X			X		X			BCPO	BCO			DED	MFD	MFD	
S&D Hydraulic Pressure			X			X		X			BCPO	BCO			DED	MFD	MFD	
S&D Hyd.Accum. #1 Quantity			X			X		X			BCPO	BCO			DED	MFD	MFD	
Ext. Pump #1 Status		X				X		X			BCPO	BCO			DED	MFD	MFD	
Ext. Pump #2 Status		X				X		X			BCPO	BCO			DED	MFD	MFD	
Port Pump Status		X				X		X			BCPO	BCO			DED	MFD	MFD	
Lead Pump Status		X				X		X			BCPO	BCO			DED	MFD	MFD	
Stbd Pump Status		X				X		X			BCPO	BCO			DED	MFD	MFD	

FUNCTIONAL REQUIREMENT: 2.3.2 (Cont'd)

INFORMATION ITEM	TIME FORM			AVAILABILITY			CRITICALITY RATING		SAMPLING RATE		CREW ASSIGNMENT			MEAS UNIT	ERROR TOLER	TYPE OF DISPLAY		
	LT STOR	ST STOR	PRES VALUE	PROJ VALUE	FAST	NORM	LOW	ALARM	LOW	CONT	4-MAN	3-MAN	2-MAN			4-MAN	3-MAN	2-MAN
2.3.2.2																		
Aft Escape Hatch Status		X			X			X	X		BCPO	BCO	BCO	-		DED	MFD	
Bridge Access Status		X			X			X	X		BCPO	BCO	BCO	-		DED	MFD	
Fwd Escape Hatch Status		X		X				X	X		BCPO	BCO	BCO	-		DED	MFD	
Wpn Ship Hatch Status		X			X			X	X		BCPO	BCO	BCO	-		DED	MFD	
Hover Backup Valve Status		X			X			X	X		BCPO	BCO	BCO	-		DED	MFD	
Hover Hull Valve Status		X			X			X	X		BCPO	BCO	BCO	-		DED	MFD	
Trim Backup Valve Status		X			X			X	X		BCPO	BCO	BCO	-		DED	MFD	
Trim Hull Valve Status		X			X			X	X		BCPO	BCO	BCO	-		DED	MFD	
Induction Backup Valve Status		X			X			X	X		BCPO	BCO	BCO	-		DED	MFD	
Induction Hull Valve Status		X			X			X	X		BCPO	BCO	BCO	-		DED	MFD	
Exhaust Backup Valve Status		X			X			X	X		BCPO	BCO	BDO	-		DED	MFD	
Exhaust Hull Valve Status		X			X			X	X		BCPO	BCO	BCO	-		DED	MFD	
Display Option Menu	X						X		X		DNA	BCO	BCO	-		DNA	MFD	
Control Function Menu	X						X		X		DNA	BCO	BCO	-		DNA	MED	
Alarm			X						X		DNA	DNA	BCO	-		DNA	MFD	

FUNCTIONAL REQUIREMENT: 2.3.2 (Cont'd)

INFORMATION ITEM	TIME FORM			AVAILABILITY		CRITICALITY RATING		SAMPLING RATE		CREW ASSIGNMENT			MEAS UNIT	ERROR TOLER	TYPE OF DISPLAY			
	LT STOR	ST STOR	PRES VALUE	PROJ VALUE	FAST	NORM	LOW	ALARM	LOW	CONT	4-MAN	3-MAN			2-MAN	4-MAN	3-MAN	2-MAN
2.3.2.6																		
Power Circuits Status		X			X			X	X		BCPO	BCO	BCO		DED	MFD	MFD	
Stern Plane Power Status		X			X			X	X		BCPO	BCO	BCO		DED	MFD	MFD	
FW Plane Power Status		X			X			X	X		BCPO	BCO	BCO		DED	MFD	MFD	
Rudder Power Status		X			X			X	X		BCPO	BCO	BCO		DED	MFD	MFD	
SCS Power Status		X			X			X	X		BCPO	BCO	BCO		DED	MFD	MFD	
Critical Circuits Power Status		X			X			X	X		BCPO	BCO	BCO		DED	MFD	MFD	
Display Option Menu	X								X		DNA	BCO	BCO		DNA	MFD	MFD	
Function Control Menu	X								X		DNA	BCO	BCO		DNA	MFD	MFD	
Alarm					X				X		BCPO	BCO	BCO		DED	DED	DED	
Oper.Proc. Checklist	X				X				X		DNA	BCO	BCO		DNA	DNA	MFD	
2.3.2.7																		
Failure Alarm					X				X		DNA	BCO	BCO		DNA	MFD	MFD	
Display Option Menu	X								X		DNA	BCO	BCO		DNA	MFD	MFD	
Function Option Menu	X								X		DNA	BCO	BCO		DNA	MFD	MFD	
Oper.Proc Checklist	X								X		DNA	BCO	BCO		DNA	DNA	MFD	

FUNCTIONAL REQUIREMENT: 2.3.2 (Cont'd)

INFORMATION ITEM 2.3.2.9	TIME FORM			AVAILABILITY			CRITICALITY RATING		SAMPLING RATE		CREW ASSIGNMENT			MEAS UNIT	ERROR TOLER	TYPE OF DISPLAY		
	LT STOR	ST STOR	PRES VALUE	PROJ VALUE	FAST	NORM	LOW	ALARM	LOW	CONT	4-MAN	3-MAN	2-MAN			4-MAN	3-MAN	2-MAN
Failure Alarm			X		X			X			DNA	BCO	BCO		DNA	MFD	MFD	
2.3.2.10																		
Failure Alarm			X		X			X		X	DNA	BCO	BCO	-	DNA	MFD	MFD	
Display Option Menu	X					X			X		DNA	BCO	BCO	-	DNA	MFD	MFD	
Function Control Menu	X					X		X	X		DNA	BCO	BCO	-	DNA	MFD	MFD	
2.3.2.11																		
MBT Vents Status		X				X		X	X		BCPO	BCO	BCO	-	DED	MFD	MFD	
Emerg Blow Valve Status		X				X		X	X		BCPO	BCO	BCO	-	DED	MFD	MFD	
Display Option Menu	X					X		X	X		DNA	BCO	BCO	-	DNA	MFD	MFD	
Function Control Menu	X					X		X	X		DNA	BCO	BCO	-	DNA	MFD	MFD	
2.3.2.12																		
Display Option Menu	X					X		X	X		DNA	DO	BCO	-	DNA	MFD	MFD	
Data Display	X					X		X	X		DNA	DO	BCO	-	DNA	MFD	MFD	
Function Control Menu	X					X		X	X		DNA	DO	BCO	-	DNA	MFD	MFD	

AD-A062 740

ROCKWELL INTERNATIONAL ANAHEIM CA AUTONETICS MARINE --ETC F/G 17/2
ADVANCED SUBMARINE CONTROL PROGRAM. (U)
OCT 78

N00024-78-C-5308

UNCLASSIFIED

C78-1091/301

NL

4 OF 4

AD
A0 62740

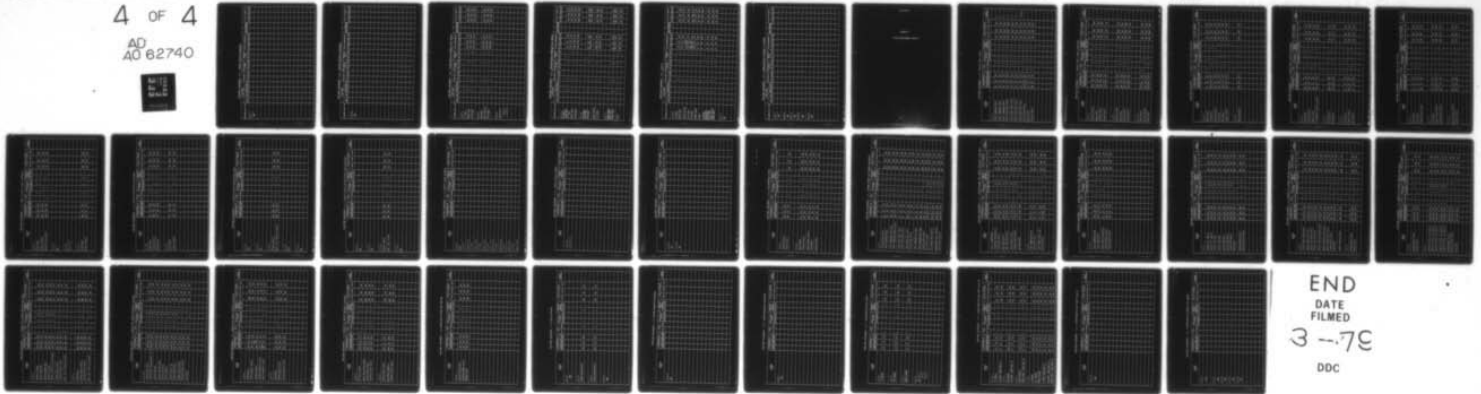

END
DATE
FILMED
3--79
DDC

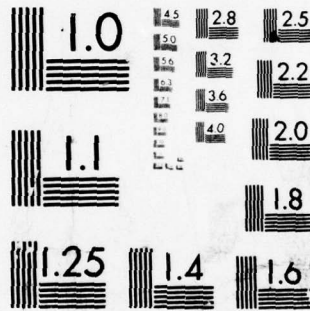

MICROCOPY RESOLUTION TEST CHART
NATIONAL BUREAU OF STANDARDS-1963-A

FUNCTIONAL REQUIREMENT: 2.6.1 PERFORM MODIFIED SUBMERGED SHIP CONTROLS

INFORMATION ITEM	TIME FORM			AVAILABILITY		CRITICALITY RATING		SAMPLING RATE		CREW ASSIGNMENT			MEAS UNIT	ERROR TOLER	TYPE OF DISPLAY	
	LT STOR	ST STOR	PRES VALUE	PROJ VALUE	NORM	LOW	ALARM	LOW	CONT	4-MAN	3-MAN	2-MAN			4-MAN	3-MAN
													STOR	STOR		
2.6.1.5																
SP Emerg Power Mode			X		X	X		X			DO	DO	SCO		DED	DED
SP Angle			X		X	X		X	X		SPO	SPO	SCO		DED	DED
Depth Deep			X		X	X		X	X		SPO	SPO	SCO		DED	DED
Dive Angle			X		X	X		X	X		SPO	SPO	SCO		DED	DED
2.6.1.6																
FWP Emerg. Power Mode			X		X	X		X	X		DO	DO	SCO		DED	DED
FWP Angle			X		X	X		X	X		FW/H	FW/H	SCO		DED	DED
Depth Shallow			X		X	X		X	X		FW/H	FW/H	SCO		DED	DED
Dive Angle			X		X	X		X	X		FW/H	FW/H	SCO		DED	DED
2.6.1.7																
Rudder Emerg Power Mode			X		X	X		X	X		DO	DO	SCO		DED	DED
Rudder Angle			X		X	X		X	X		FW/H	FW/H	SCO		DED	DED
Course			X		X	X		X	X		FW/H	FW/H	SCO		DED	DED

C78-109/301

APPENDIX F

ACTION REQUIREMENTS ANALYSIS

FUNCTIONAL REQUIREMENT: 2.1.1 Maintain Ship's Safety (continued)

ACTION ITEM	RESPONSIBILITY			AVAIL.		CRITICALITY RATING		SAMPLING RATE REQUIRED		TYPE OF CONTROL			ERROR TOLERANCE
	4-MAN CREW	3-MAN CREW	2-MAN CREW	FAST	NORM	PRIME	BCKUP	LOW	CONT	4-MAN	3-MAN	2-MAN	
2.1.1.2													
Display Control	DNA	BCO	BCO		X	X		X		DNA	MFD	MFD	
Menu Select	DNA	BCO	BCO		X	X		X		DNA	MFD	MFD	
Message Select	DNA	BCO	BCO		X	X		X		DNA	MFD	MFD	
Alarm Control	BCPO	BCO	BCO	X		X		X		DED	DED	DED	
2.1.1.3													
Display Control	DNA	BCO	BCO		X	X		X		DNA	MFD	MFD	
Menu Select	DNA	BCO	BCO		X	X		X		DNA	MFD	MFD	
Message Select	DNA	BCO	BCO		X	X		X		DNA	MFD	MFD	
Alarm Control	BCPO	BCO	BCO	X		X		X		DED	DED	DED	
2.1.1.4													
Mode Control	BCPO	D0	BCO	X		X		X		DED	MFD	MFD	
Display Control	DNA	BCO	BCO		X	X		X		DNA	MFD	MFD	
Alarm Reset	BCPO	BCO	BCO		X	X		X		DED	MFD	MFD	

FUNCTIONAL REQUIREMENT: 2.1.1 Maintain Ship's Safety (continued)

ACTION ITEM	RESPONSIBILITY				AVAIL.		CRITICALITY RATING		SAMPLING RATE REQUIRED		TYPE OF CONTROL			ERROR TOLERANCE
	4-MAN CREW	3-MAN CREW	2-MAN CREW	FAST	NORM	PRIME	BACKUP	LOW	CONT	4-MAN	3-MAN	2-MAN		
													DNA	
2.1.1.7														
Alarm Reset	DNA	DO	BCO		X		X	X		DNA	MFD	MFD		
Display Control	DNA	DO	BCO		X		X	X		DNA	MFD	MFD		
Option Select	DNA	DO	BCO		X		X	X		DNA	MFD	MFD		
Procurement Checklist Control	DNA	DO	BCO		X		X	X		DNA	MFD	MFD		
2.1.1.8														
Alarm Control	BCPO	BCO	BCO	X			X	X		DED	DED	DED		
Alarm Reset	BCPO	BCO	BCO	X			X	X		DED	DED	DED		
2.1.1.9														
Alarm Reset	DO	DO	SCO	X			X	X		DED	MFD	MFD		
Display Control	DNA	DO	SCO		X		X	X		DNA	MFD	MFD		
Mode Control	DO	DO	SCO		X		X	X		DED	MFD	MFD		

FUNCTIONAL REQUIREMENT: 2.3.1 PERFORM PRIMARY SHIP CONTROL FUNCTION(S)

ACTION ITEM	RESPONSIBILITY		AVAIL.		CRITICALITY RATING		SAMPLING RATE REQUIRED		TYPE OF CONTROL			ERROR TOLERANCE	
	4-MAN CREW	3-MAN CREW	2-MAN CREW	FAST	NORM	PRIME	BACKUP	LOW	CONT	4-MAN	3-MAN		2-MAN
2.3.1.1													
Steering Mode Select	D0	D0	SCO		X		X	X		DED	MFD	MFD	
Enter Commanded Depth	D0	D0	SCO		X		X	X		DED	MFD	MFD	
Enter Commanded Depth Rate	DNA	D0	SCO		X		X	X		DNA	MFD	MFD	
Enter Commanded Depth Accuracy	DNA	D0	SCO		X		X	X		DNA	MFD	MFD	
Enter Plane Angle Limits	D0	D0	SCO		X		X	X		DED	MFD	MFD	
Enter Pitch Angle Limits	D0	D0	SCO		X		X	X		DED	MFD	MFD	
Enter Depth Rate Limits	DNA	D0	SCO		X		X	X		DNA	MFD	MFD	
Ballast Mode Select	D0	D0	BCO		X		X	X		DED	MFD	MFD	
Enter Commanded SP Angle	DNA	D0	SCO		X		X	X		DNA	MFD	MFD	
Enter Commanded FWP Angle	DNA	D0	SCO		X		X	X		DNA	MFD	MFD	
Display Option Select	DNA	ALL	ALL		X			X		DNA	MFD	MFD	
Hull Valve Control	BCP0	BC0	BC0		X		4	3/2	X	DED	MFD	MFD	
Hull Backup Valve Control	BCP0	BC0	BC0		X		4	3/2	X	DED	MFD	MFD	
Destination Valve Controls	BCP0	BC0	BC0		X		4	3.2	X	DED	MFD	MFD	
Source Valve Controls	BCP0	BC0	BC0		X		4	3/2	X	DED	MFD	MFD	

FUNCTIONAL REQUIREMENT: 2.3.2 MONITOR SHIP CONTROL FUNCTIONS (Continued)

ACTION ITEM	RESPONSIBILITY		AVAIL.		CRITICALITY RATING		SAMPLING RATE REQUIRED		TYPE OF CONTROL			ERROR TOLERANCE
	4-MAN CREW	3-MAN CREW	FAST	NORM	PRIME	BACKUP	LOW	CONT	4-MAN	3-MAN	2-MAN	
2.3.2.2												
Control Hover Backup Valve	BCPO	BCO		X	4		X		DED	MFD	MFD	
Control Hover Hull Valve	BCPO	BCO		X	4		X		DED	MFD	MFD	
Control Trim Backup Valve	BCPO	BCO		X	4		X		DED	MFD	MFD	
Control Trim Hull Valve	BCPO	BCO		X	4		X		DED	MFD	MFD	
Control Induction Backup Valve	BCPO	BCO		X	4		X		DED	MFD	MFD	
Control Induction Hull Valve	BCPO	BCO		X	4		X		DED	MFD	MFD	
Control Exhaust Hull Valve	BCPO	BCO		X	4		X		DED	MFD	MFD	
Display Option Select	DNA	BCO		X		X	X		DNA	MFD	MFD	
Alarm Reset	DNA	BCO		X	X		X		DNA	DNA	MFD	
Control Function Select	DNA	BCO		X		X	X		DNA	MFD	MFD	
2.3.2.3												
Display Option Select	DNA	DNA		X		X	X		DNA	DNA	MFD	
Message Select	DNA	DNA		X		X	X		DNA	DNA	MFD	

FUNCTIONAL REQUIREMENT: 2.3.2 MONITOR SHIP CONTROL FUNCTIONS (Continued)

ACTION ITEM	RESPONSIBILITY		AVAIL.	CRITICALITY RATING		SAMPLING RATE REQUIRED		TYPE OF CONTROL			ERROR TOLERANCE
	4-MAN CREW	3-MAN CREW		PRIME	BACKUP	LOW	CONT	4-MAN	3-MAN	2-MAN	
2.3.2.6											
Control SP Power	BCPO	BCO	X	4	3/2	X		DED	MFD	MFD	
Control FWP Power	BCPO	BCO	X	4	3/2	X		DED	MFD	MFD	
Control Rudder Power	BCPO	BCO	X	4	3/2	X		DED	MFD	MFD	
Control SCS Power	BCPO	BCO	X	4	3/2	X		DED	MFD	MFD	
Control Critical Circuits Power	BCPO	BCO	X	4	3/2	X		DED	MFD	MFD	
Display Option Select	DNA	BCO	X		X	X		DNA	MFD	MFD	
Function Control Select	DNA	BCO	X		X	X		DNA	MFD	MFD	
Oper. Proc. Checklist Control	DNA	BCO	X		X	X		DNA	DNA	MFD	
2.3.2.7											
Alarm Reset	DNA	BCO	X	X		X		DNA	MFD	MFD	
Display Option Control	DNA	BCO	X		X	X		DNA	MFD	MFD	
Function Option Control	DNA	BCO	X	X		X		DNA	MFD	MFD	
Oper. Proc. Checklist Control	DNA	BCO	X		X	X		DNA	DNA	MFD	

FUNCTIONAL REQUIREMENT: 2.6.1 PERFORM MODIFIED SHIPS SAFETY (Cont'd)

ACTION ITEM	RESPONSIBILITY			AVAIL.		CRITICALITY RATING		SAMPLING RATE REQUIRED		TYPE OF CONTROL			ERROR TOLERANCE
	4-MAN CREW	3-MAN CREW	2-MAN CREW	FAST	NORM	PRIME	BACKUP	LOW	CONT	4-MAN	3-MAN	2-MAN	
2.6.1.5													
SP CONTROL	SPO	SCO	SCO	X			X		X	DED	DED	DED	
SP EMERG. POWER MODE SET	DO	DO	SCO	X			X		X	DED	DED	DED	
2.6.1.6													
FWP CONTROL	FW/H	SCO	SCO	X			X		X	DED	DED	DED	
FWP EMERG. POWER MODE SET	DO	DO	SCO	X			X		X	DED	DED	DED	
2.6.1.7													
RUDDER CONTROL	FW/H	SCO	SCO	X			X		X	DED	DED	DED	
RUDDER EMERG. POWER MODE SET	DO	DO	SCO	X			X		X	DED	DED	DED	
2.6.1.8													
SP CONTROL	SPO	SCO	SCO	X			X		X	DED	DED	DED	
FWP. CONTROL	FW/H	BCO	SCO	X			X		X	DED	DED	DED	
RUDDER CONTROL	DO	DO	BCO	X			X		X	DED	DED	DED	
SP EMERG POWER MODE SET	DO	DO	SCO	X			X		X	DED	DED	DED	
FWP EMERG. POWER MODE SET	DO	DO	SCO	X			X		X	DED	DED	DED	
RUDDER EMERG. POWER MODE SET	DO	DO	SCO	X			X		X	DED	DED	DED	

