

AD-A062 747

ITT ELECTRO-OPTICAL PRODUCTS DIV FORT WAYNE IND  
DEVELOPMENT OF 12 MM PROXIMITY FOCUSED TWO-STAGE DIODE.(U)  
MAY 78 T F LYNCH

F/G 9/1

DAAK70-76-C-0248

NL

UNCLASSIFIED

1 OF 1  
AD  
A062 747

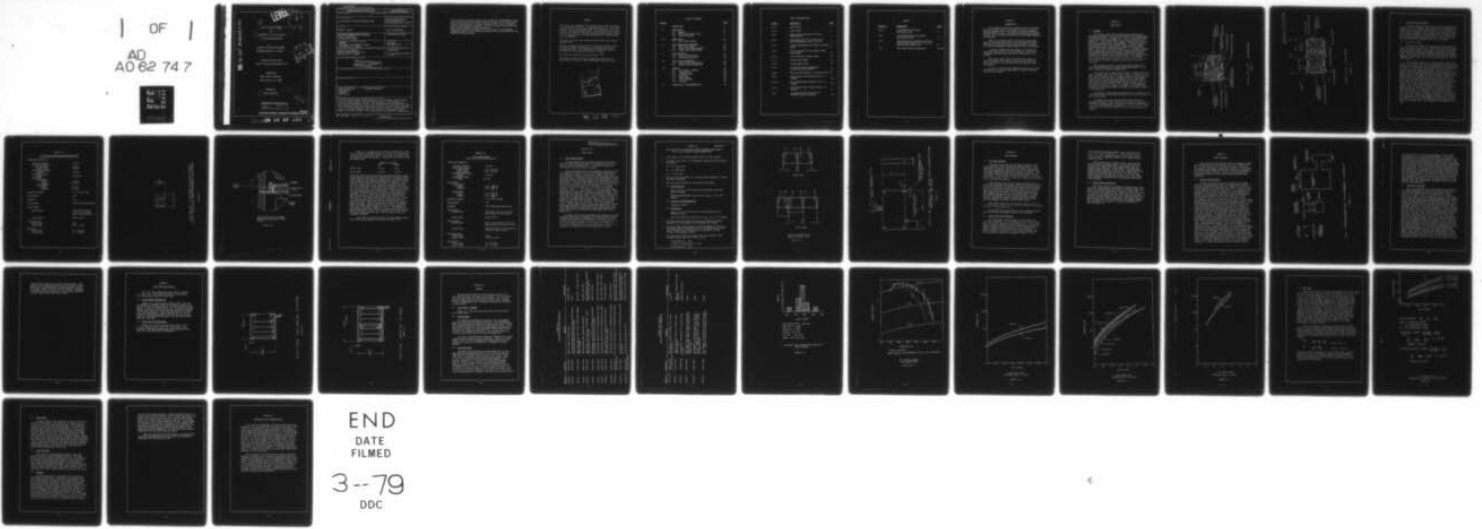

END  
DATE  
FILMED  
3--79  
DDC

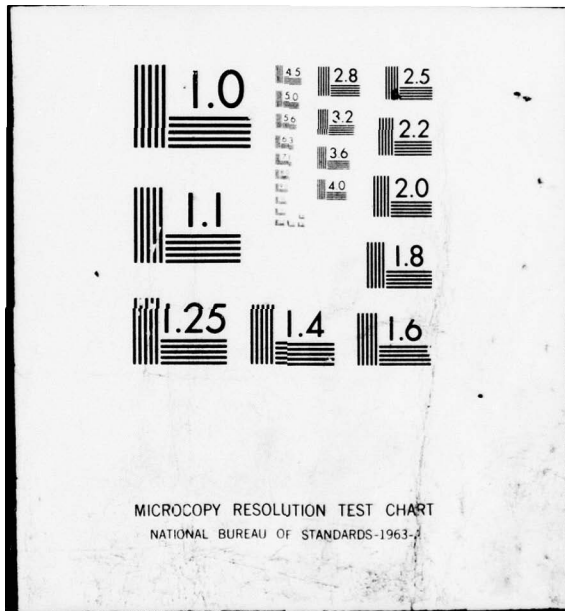

DDC FILE COPY AD A062747

**LEVEL II** (6)

9

Final Technical Report, Oct 76 - Nov 77

for

6

Development of 12 mm Proximity  
Focused Two-Stage Diode

15

Contract No. DAAK 70-76-C-0248

ITT/EOPD Project No. 11-25300

DDC  
JAN 2 1979  
RESISTIVE  
F

Covering the Period From  
October 1976 through November 1977

Prepared for  
Night Vision Laboratory  
Fort Belvoir, Va. 22060

10

Prepared by  
Thomas F. Lynch

11 May 78

12 Hep.

This document has been approved  
for public release and sale; its  
distribution is unlimited.

ELECTRO-OPTICAL PRODUCTS DIVISION **ITT**

3888178 11 13 124 B

REPORT DOCUMENTATION PAGE		READ INSTRUCTIONS BEFORE COMPLETING FORM
1. REPORT NUMBER	2. GOVT ACCESSION NO.	3. RECIPIENT'S CATALOG NUMBER
4. TITLE (and Subtitle)  12 mm Proximity Focused Two-Stage Diode		5. TYPE OF REPORT & PERIOD COVERED Final Technical Report Oct '76 - Nov '77
7. AUTHOR(s)  Thomas F. Lynch		6. PERFORMING ORG. REPORT NUMBER
9. PERFORMING ORGANIZATION NAME AND ADDRESS ITT Electro-Optical Prod. Division 3700 E. Pontiac St. Fort Wayne, IN. 46803		8. CONTRACT OR GRANT NUMBER(s)  DAAK 70-76-6-2048 <sup>2</sup>
11. CONTROLLING OFFICE NAME AND ADDRESS USAMERDC Procurement and Production Office Fort Belvoir, VA 22060		10. PROGRAM ELEMENT, PROJECT, TASK AREA & WORK UNIT NUMBERS
14. MONITORING AGENCY NAME & ADDRESS (if different from Controlling Office) Night Vision Laboratory USAECOM, DRSEL-NV-SD Bldg. 357 Fort Belvoir, VA 22060		12. REPORT DATE May 1978
		13. NUMBER OF PAGES 36
		15. SECURITY CLASS. (of this report) Unclassified
16. DISTRIBUTION STATEMENT (of this Report)		15a. DECLASSIFICATION/DOWNGRADING SCHEDULE
<div style="border: 1px solid black; padding: 5px; width: fit-content; margin: auto;"> <p>This document has been approved for public release and sale; its distribution is unlimited.</p> </div>		
17. DISTRIBUTION STATEMENT (of the abstract entered in Block 20, if different from Report)		
18. SUPPLEMENTARY NOTES		
19. KEY WORDS (Continue on reverse side if necessary and identify by block number) Image Intensifiers                      Proximity Focusing Photocathodes Phosphors Fiber Optics		
20. ABSTRACT (Continue on reverse side if necessary and identify by block number) A 12 mm proximity focused double diode and a 12 mm proximity focused triple diode have been designed, fabricated and delivered. Power supplies were designed, fabricated and delivered. All photocathodes on the tubes were S-20 with extended red response. Both input and output faceplates were fiber optics. The 12 mm double diode output fiber optic was an inverter. A special feature of the 12 mm double diode was that it was actually two proximity focused diodes in one tube envelope. This unique design was achieved by transferring		

*micro* *micro*

a fiber optic containing a phosphor on one side and a photocathode on the other side into the tube envelope forming the center of the double diode. A triple diode was made by placing a single diode in front of a double diode and bonding the two together. The power supplies were miniaturized and all self-contained including batteries. Photocathode sensitivities ranged from 126  $\mu\text{a}/\text{lumen}$  to 400  $\mu\text{a}/\text{lumen}$ . Brightness gains of up to 5000 were achieved on the double diodes and over 10000 on the triple diodes.

FORWARD

This report was prepared by the Electro-Optical Products Division of International Telephone and Telegraph Corporation. Fort Wayne, Indiana, under contract number DAAK 70-76-C-0248 entitled "12 mm Proximity Focused Two-Stage Diode". The program was sponsored by the U.S. Army Mobility Equipment Research and Development Command Fort Belvoir, Virginia. Mr. William Markey COR was project manager for USAMERDC.

This report describes work conducted from October 1976 through November 1977.

The Tube and Sensor Laboratories of the Electro-Optical Products Division, International Telephone and Telegraph Corporation, performed the work. The program was a group effort headed by Mr. Thomas F. Lynch, assisted by Albert J. Knight.

The report was submitted by the author May, 1978.

This technical report has been reviewed and is approved for publication by William F. Markey, COR Night Vision Laboratory.

APPROVED	Write Section <input checked="" type="checkbox"/>
DDC	n. r. Section <input type="checkbox"/>
UNCLASSIFIED	<i>for file</i>
JUSTIFICATION	
BY	DISTRIBUTION STATEMENT CODES
DATE	CLASSIFICATION
A	-

78 11 13 124

## TABLE OF CONTENTS

<u>Section</u>		<u>Page</u>
I	INTRODUCTION	1
II	TUBE DESIGN	2
	2.1 General	2
	2.2 Design Requirement Goals	5
	2.3 Final Tube Design	5
III	POWER SUPPLY	11
	3.1 Power Supply Design	11
IV	TUBE ASSEMBLY AND PROCESSING	15
	4.1 Tube Body Assembly	15
	4.2 Center Fiber Optic Assembly	15
	4.3 Triple Diode Construction	16
V	TUBE PROCESSING	17
	5.1 Process Station Design	17
	5.2 Processing Procedure	19
VI	FINAL TUBE CONFIGURATION	21
	6.1 Double Diode Configuration	21
	6.2 Triple Diode Configuration	21
VII	RESULTS	24
	8.1 Tube Starts - Summary	24
	8.2 Photocathodes	24
	8.3 Brightness Gain	24
	8.4 Resolution	32
	8.5 Power Supply	34
	8.6 Items Delivered	34
	8.7 Problems	34
IX	CONCLUSIONS AND RECOMMENDATIONS	36

LIST OF ILLUSTRATIONS

<u>FIGURE</u>	<u>DESCRIPTION</u>	<u>PAGE</u>
2.1-1	Double Diode	3
2.1-2	Triple Diode	4
2.3-1	Double Diode (Unpotted) Full Scale Representation	7
2.3-2	Cross-Sectional View of Center Fiber Optic/Photocathode Locked in Place	8
3.1-1	Voltage Requirements for Double and Triple Diode	13
3.1-2	Outline Drawing for 12 mm Double Diode Power Supply	14
5.1-1	12 mm Processing Chamber Layout	18
6.1-1	Potted Double Diode	22
6.1-2	Potted Triple Diode	23
8.2-1	12 mm Double Diode Photocathode Sensitivity $\mu\text{A/LU}$ @ 2854 <sup>o</sup> K	27
8.2-2	Mean Spectral Response 12 mm Double Diode	28
8.3-1	12 mm Single Diode Brightness Gain vs. Voltage	29
8.3-2	12 mm Double Diode Brightness Gain vs. Voltage	30
8.3-3	12 mm Triple Diode Brightness Gain vs. Voltage	31
8.4-1	12 mm Double Diode Resolution vs. Voltage at Various Spacings	33

TABLES

<u>TABLE NO.</u>	<u>DESCRIPTION</u>	<u>PAGE</u>
2.2-1	12 mm Double Diode Design Requirement Goals	6
2.3-1	12 mm Double Diode Final Design Goal Specifications	10
3.1-1	Specification for Miniaturized Battery- Operated Power Supply for a 12 mm Prox- imity Focused Double Diode	12
8.1-1	Tube Starts and Tube Disposition	25 & 26

## SECTION I

### INTRODUCTION

This document is the final technical report of contract DAAK 70-76-C-2048 entitled "Development of 12 mm Proximity Focused Two-Stage Tube". The design, development fabrication and performance of both a two-stage and three-stage proximity focused image intensifier and their associated power supplies is presented.

Under this program several two-stage and three-stage tubes with an active area of 12 mm were designed and built. The tubes all used basic technologies available for larger tubes and some advanced concepts required by the tube design.

A special miniaturized power supply was designed and built under subcontract to K & M Electronics. These were integrated with each tube assembly and evaluated as a unit by ITT.

This report deals with the proposed tube design, the final tube design, the results of the tubes processed and the test results of all the tubes made and delivered under the program.

It was the intent of this program to provide a low cost alternative to the medium range needs of image intensification for night vision.

## SECTION II

### TUBE DESIGN

#### 2.1 General

The design of this tube is based on the principles of proximity focusing and having two photocathodes and two phosphors in the same envelope. As Figure 2.1-1 shows, in the double diode design both of the photocathodes are in close proximity to the phosphors. A high voltage field gradient between them serves to focus the photoelectrons on the phosphors. In order to achieve the requirement for a triple diode a single diode of similar dimensions was made and physically bonded to a special double diode. This device is shown in Figure 2.1-2. In order to achieve the necessary high electro-static field gradients between each input photocathode and output phosphor both input and output windows have a pedestal or re-entrant design. This design allows for the close spacing between the photocathode and phosphor while permitting longer insulators to be used in the body structure withstand the high voltage requirement needed for tube operation.

The center fiber optic of the double diode contained the first stage phosphor and the second stage photocathode. It was held in place by a spring retaining ring.

The overall tube is made from a ceramic to metal brazed tube body. A copper ring, which will later contain the indium for the photocathode faceplate seal, is brazed to the top of the tube body. The center of the tube body, held between the two high alumina ceramic rings, holds the locking spring for the center fiber optic which is held in place between the two capture rings. The locking ring secures the rim of the capture ring thus holding the center fiber optic in place. A flange at the bottom end of the tube body allows the output fiber optic to be heliarc welded to the tube body.

This design is made possible through the use of remote photocathode processing techniques which are used in the final sealing of the completed tube.

As stated before this design utilizes the principle of proximity focusing in which focusing is a function of only the transverse emission energy of the electrons and the field strength between the photocathode and phosphor. The field strength is determined by the voltage and spacing between the photocathode and phosphor.

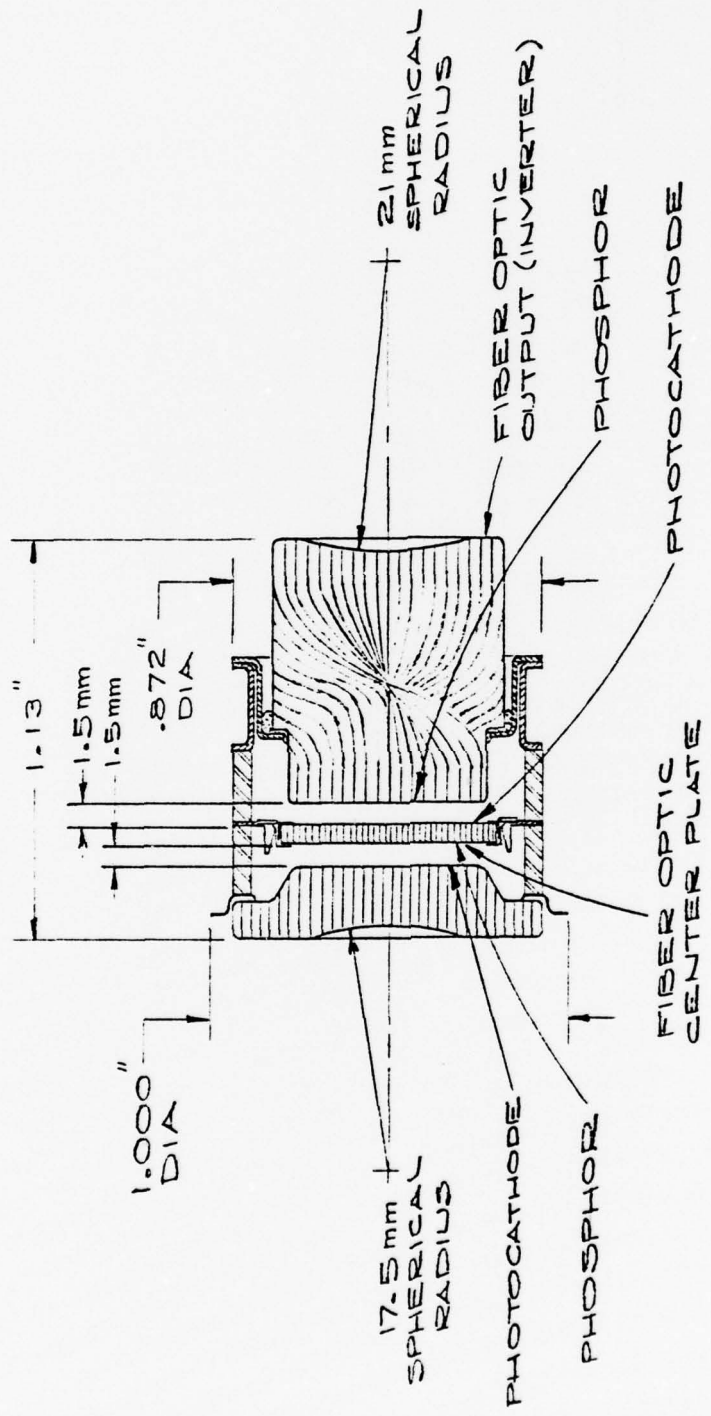

DOUBLE DIODE

FIGURE 2.1-1



## 2.2 Design Requirement Goals

Several design requirement goals and specifications were proposed for this program. After initiation of the program some changes were made. These changes involved the concept of the triple diode as proposed and the addition of radii of curvature on all input faceplates. These changes will be discussed under the following section of the report describing the final tube designs for both double and triple diodes. Table 2.2-1 lists the original design requirement goals for the program.

## 2.3 Final Tube Design

The final tube design for the double and triple diode is shown in Figure 2.1-1 and 2.1-2. Modifications to the original concept involved changes in the radii of curvature of the input and output fiber optics and the design concept for the triple diode. These were made under contract modification in consideration of the system optics in which the tubes would be eventually operated. Figure 2.3-1 is a full scale representation of the double diode.

The tube body consists of a brazed ceramic to metal assembly. Two ceramics .200 in. long separated by a mounting ring for the center fiber optic made up the major part of double diode tube body. A copper seal ring was placed on the input end and a weld ring for the output fiber optic on the output end. A spring locking ring was attached to the center mounting ring in order to lock the Phosphor/Photocathode assembly in place. This locking spring was designed so that the center Phosphor/Photocathode could be transferred into the tube body. In order to achieve this the Phosphor/Photocathode was mounted in a two-piece ring structure. The end near the photocathode was flared out so that it would lock under the springs in the locking spring. A sketch of this locking spring assembly is shown in Figure 2.3-2. The complete assembly only requires the use of three parts since the locking spring was designed from one piece of material. The completed tube required the output fiber optic, fritted to a flange, be welded to the output weld ring. The photocathode was sealed to the input ring using a hot indium seal. After photocathode processing first operation was transferring the center Phosphor/Photocathode into the tube body and the second and final operation was sealing the faceplate to the copper ring. This completed final assembly of the tube.

TABLE 2.2-1

12 mm DOUBLE DIODE DESIGN REQUIREMENT GOALS

## Mechanical Demensions:

Tube body diameter -	.870 IN.
Overall tube length	
Double Diode -	1.16 IN.
Triple Diode -	1.76 IN.
Photocathode/Phosphor	
Spacing -	.065 IN.
Input/Output Image	
Format -	12 mm DIA.
Potted Tube	
Double Diode	
Length -	1.16 IN.
Diameter -	1.11 IN.
Triple Diode	
Length -	1.76 IN.
Diameter -	1.11 IN.
Operating Voltage -	5 to 7KV per stage
Photocathode -	S25
Phosphor -	P-20
Input Window -	Fiber Optic (plano-plano)
Output Window	
Double Diode -	Fiber Optic Inverter with 1.575" spherical radius output surface.
Triple Diode -	Same as above
Brightness Gain	
Double Diode	1000
Triple Diode	7000 - 10,000
Resolution	
Double Diode	30 - 40 lp/mm
Triple Diode	26 - 28 lp/mm

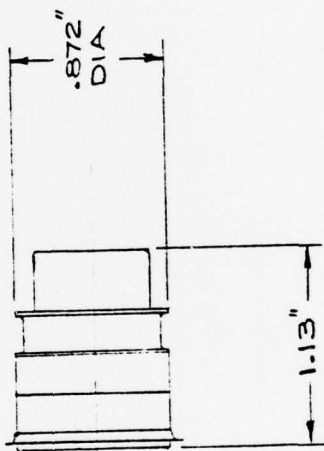

DOUBLE DIODE (UNPOTTED)  
FULL SCALE REPRESENTATION

FIGURE 2.3-1

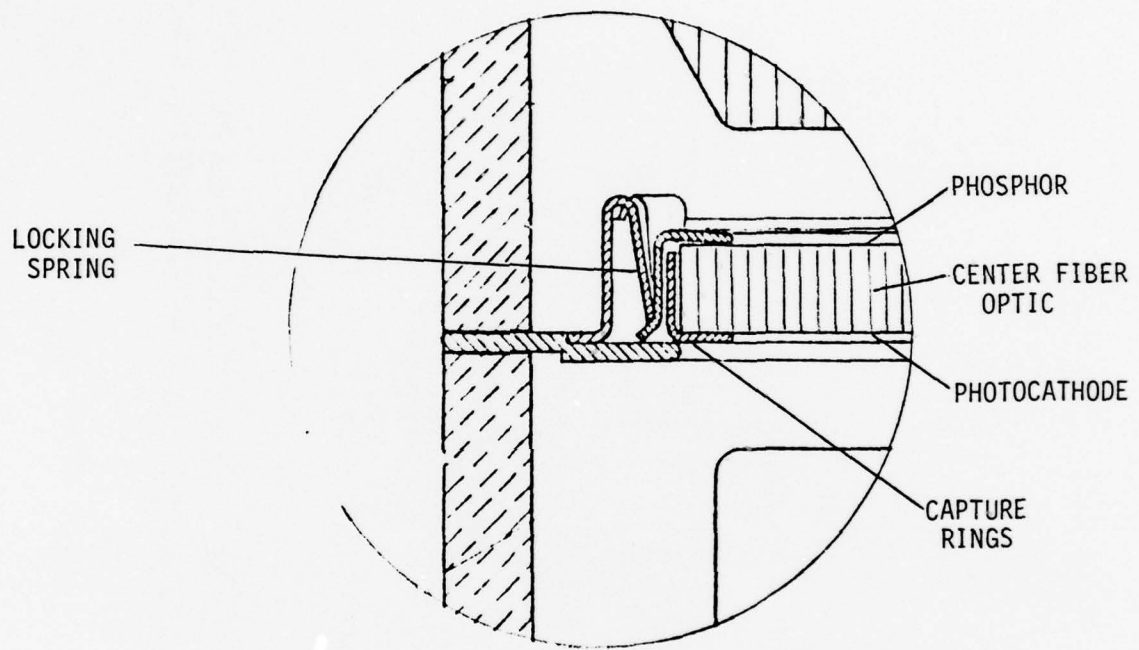

CROSS-SECTIONAL VIEW OF CENTER  
FIBER OPTIC/PHOTOCATHODE LOCKED  
IN PLACE

FIGURE 2.3-2

Early in the program before the parts' drawings were finalized a change was requested by NVL on the radii of curvature for the input and output fiber optics. As a result the final design incorporated the following radii of curvature into both the double and triple diode:

	Radii of Curvature	
	Input	Output
Double Diode	17.5 mm	21 mm
Triple Diode	17.5 mm	11.5 mm

The triple diode design concept was changed from having a single diode coupled to the output of a double diode to having a single diode coupled to the input of a double diode. The double diode for the triple diode therefore required the output to be a plano-plano fiber optic with the 11.5 mm radius of curvature. The original concept called for a fiber optic inverter in the output. The double diode system optics required that the output of the tube be inverted. It was therefore necessary to use a fiber optic inverter on the double diode output. Since this inverter is already manufactured for 18 mm devices, a rough blank was available. A few of these were secured from the manufacturer, American Optical, to use in determining how to make a 12 mm unit from it. The problem was to grind and polish the inverter down to the proper size, for diameter, length, and radius of curvature without cutting into the twisted fibers and causing image distortion. After two grindings on each of two separate blanks the proper length was found which provided a distortion free image. The overall length was .750 in. Photographs of grid patterns transmitted through the fiber optics were used to measure distortion. None could be measured on the final design. The overall tube length was then .030 inch shorter than that originally proposed.

As a result of the design effort the specification goals for the tubes were modified as presented in Table 2.3-1.

TABLE 2.3-1

12 mm DOUBLE DIODE  
FINAL DESIGN GOAL SPECIFICATIONS

## Mechanical Dimensions

Tube Body Diameter -	.872 IN.
Overall Tube Length	
Double Diode -	1.13 $\pm$ .020 IN.
Triple Diode -	1.57 $\pm$ .020 IN.
Photocathode/Phosphor Spacing	.065 IN.
Input/Output Image Format	12.0 mm
Potted tube	
Double Diode	
Length -	1.13 $\pm$ .020 IN.
Diameter	1.06 $\pm$ .000 IN. - .005
Triple Diode	
Length	1.57 $\pm$ .020 IN.
Diameter	1.06 $\pm$ .000 IN. - .005
Operating Voltage	5 to 7 KV per stage
Photocathode	S-25
Phosphor	P-20 W/darkened aluminum film
Input Window	
Double Diode	Fiber Optic with 17.5 mm spherical radius on input surface.
Triple Diode	Same as above
Output Window	
Double Diode	Fiber Optic Inverter with 21 mm spherical radius on output surface.
Triple Diode	Fiber Optic with 11.5 mm spherical radius on output surface.
Brightness Gain	
Double Diode	1,000
Triple Diode	7,000 to 10,000
Resolution	
Double Diode	30 - 40 lp/mm
Triple Diode	26 - 28 lp/mm

SECTION III

POWER SUPPLY

3.1 Power Supply Design

The power supply for the double diode had to be a dual supply so that both photocathodes, and phosphors could be run with at least 7 KV between them. In the case of the triple diode there were three outputs required.

During the design phase of the program an analysis of the tube operation was done to fix the power supply requirements. As a result the tentative specification shown in Table 3.1-1 was generated. It was also possible to use the same supply for the triple diode. This was achieved with the flexibility of adjustment built into the power supply by the manufacturer, K & M Electronics. It was also made possible by using fiber optics on the output of the first stage and the input of the second stage with a coupling method capable of withstanding the voltage gradient. The final triple diode was to be run by parallel operation of the two stages on or half the power supply and running the last stage the same as in a double diode. Both Bright Source Protection and Automatic Brightness Control circuits were built into the supply. The ABC circuit was specified to maintain, at high light level inputs, at least a voltage equal to the phosphor dead voltage. This way the tube would not completely turn off with high light input and still provide usable imagery under this condition. This was achieved by using a voltage clamp circuit in the power supply which limited the phosphor voltage to the phosphor dead voltage under high light conditions. The resultant voltage requirements and wiring hookup for both the double and triple diode are shown in Figure 3.1-1

The final size of the power supply was changed due to both a request from K & M to standardize and from the optics system designer, Baird-Atomic, for optimization in fitting the goggles in which the tubes and power supplied were to be mounted. The change was easily accommodated. The final size as shown in 3.1-2 was 3/5 inches long 2.0 inches wide and .4 inches thick including two batteries, on-off switch and flying leads.

TABLE 3.1-1

(Tentative)

SPECIFICATION FOR MINIATURIZED BATTERY-OPERATED POWER SUPPLY  
FOR A 12 MM PROXIMITY FOCUSED DOUBLE DIODE

1. Power supply to be battery operated from a 5.0 volt battery.
2. The power supply shall be a rectangular volume with the following dimensions:
  - (a) 2.2 inches long
  - (b) 1.8 inches wide
  - (c) 1.0 inch high
3. The unit shall be encased in a suitable potting compound to insure electrical isolation.
4. The supply shall provide the following tube voltages:
  - (a) Photocathode #1  
 $E_{PC1} = (-5.0 \text{ to } -7.0)$  Kilovolts with adjustment over the specified range  
  
 Maximum Photocathode #1 current will be  $I_{PC1} = 2.5 \times 10^{-8}$  amperes.
  - (b) Phosphor #1/Photocathode #2  
 $E_{PH1}/E_{PC2} = \text{Ground}$
  - (c) Phosphor #2  
 $E_{PH2} = (+5 \text{ to } +7.0)$  Kilovolts with adjustment over the specified range.  
  
 Maximum Phosphor #2 current will be  $I_{PH2} = 3.5 \times 10^{-7}$  amperes
5. The power supply will provide suitable trim pots for voltage adjustments on Photocathode #1 and Phosphor #2 voltages.
6. The power supply shall control the tube brightness by monitoring the second stage or Phosphor #2 current and adjusting the first stage voltage down to no less than 2.5 Kilovolts, the dead voltage of the phosphor screen.
7. The power supply shall be provided with three external leads for connection to the tube. They will be:
 

Photocathode #1 - -7KV  
 Phosphor #1/Photocathode #2 - GND  
 Photocathode #2 - +7KV

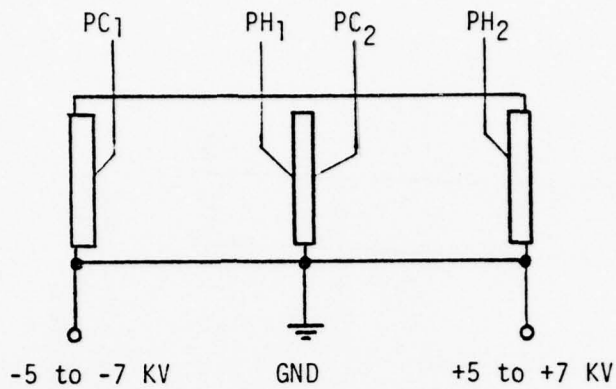

DOUBLE DIODE

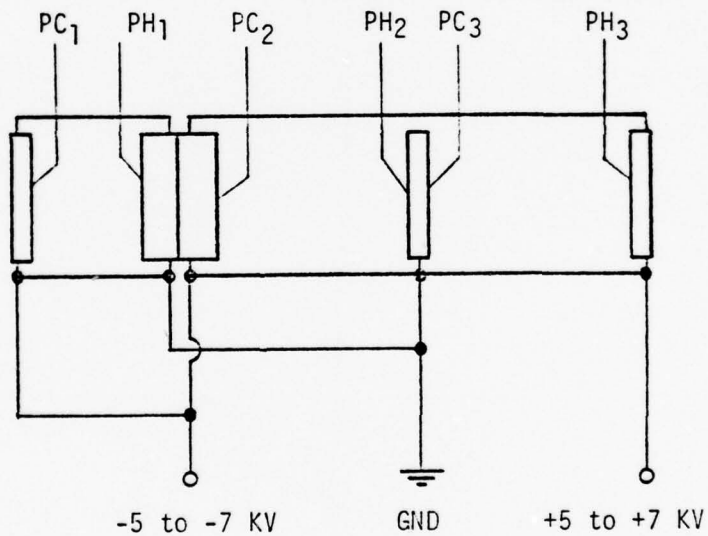

TRIPLE DIODE

VOLTAGE REQUIREMENTS FOR  
DOUBLE AND TRIPLE DIODE

FIGURE 3.1-1

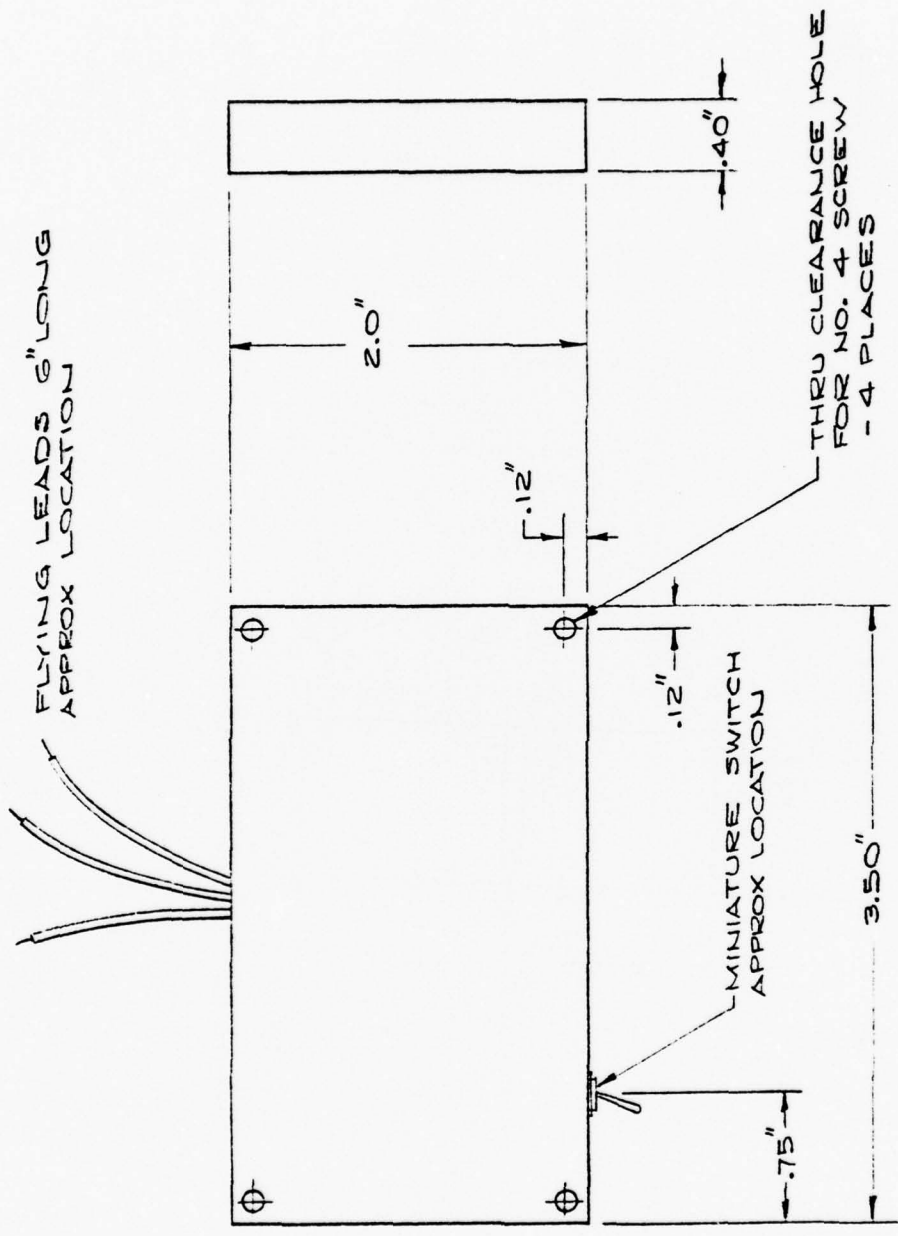

OUTLINE DRAWING FOR 12mm DOUBLE DIODE  
 POWER SUPPLY

FIGURE 3.1-2

## SECTION IV

### TUBE ASSEMBLY

#### 4.1 Tube Body Assembly

The double diode tube body was brazed together in one single operation using a break-apart brazing fixture. The break-apart feature was used due to the center plate support ring which was placed in the center of the two ceramics. The fixturing automatically made all of the parts concentric with one another within the prescribed tolerances needed for the final tube. A single diode tube body was brazed for the triple diode using the same fixture. Parts of the fixture used for the double tube body were removed.

After brazing, the tube body was leak checked and the input ring was filled with indium. After the indium was trimmed to size the tube body was vacuum baked again and then cleaned. Next the center plate locking ring was inserted into the tube body using a special fixture and laser welded into position. Laser welding was chosen due to the minimal clearance available between this part and the tube body ceramic. It would not have been possible to get a conventional spot welding electrode between the capture ring and the ceramic without risk of scraping the ceramic with the welding tool.

The flanged fiber optic output screen was then Heli-arc welded into the finished tube body and this assembly leak checked and held for final processing.

No problems were encountered with these assembly methods and they were used throughout execution of the program.

#### 4.2 Center Fiber Optic Assembly

The center fiber optic was made .050 inch thick and .587 inch in diameter. It was required that one side of this piece have a P-20 phosphor screen settled on it. At the same time the opposite side had to remain uncontaminated during the phosphor screen settling operation so that a photocathode could be formed on it later during the tube processing. In order to maintain cleanliness a novel fixture was made that held the plate in position for phosphor settling by means

of an O-Ring seal around the edge. This O-Ring seal kept the back side of the plate dry. A window was put on the back side of the fixture so that the fiber optic could be viewed during all operations making sure no leaks occurred around the seal.

After processing the phosphor screen, the plate was placed between two capture rings. One ring had a beveled out edge which caught under the locking spring that was mounted in the tube body. These capture rings were laser welded together securing the fiber optic. Laser welding was selected again because the weld had to be placed down in between the rings and there was no safe way to use a spot welder because of the small size of the parts. This method also eliminated any sharp points being exposed and causing field emission.

#### 4.3 Triple Diode Construction

The triple diode was constructed by making single diode containing a photocathode and phosphor utilizing a simple tube body with a single ceramic and an input and output ring. A special double diode was made for coupling to this single diode by using different input and output fiber optics on the same tube body as the standard double diode. After both tubes were made and qualified a small coupling ring was placed between them to align each fiber optic and they were bonded together with Lens-Bond M-72 a product of Sommers Laboratories of Fort Washington, Pa.

## SECTION V

### TUBE PROCESSING

Due to the unique tube design a special processing chamber and procedures were set up allowing for a very flexible process. As for example at the end of the process, before seal, the complete tube could be operated and checked. At this point a decision could be made on making the final seal or reprocessing using the same tube body. Another fixture allowed easy transfer and locking of the second stage photocathode after processing.

#### 5.1 Process Station Design

In order to allow for the unique design of the double diode the vacuum processing station was made very flexible. It included provisions for measuring all components of each tube and the finished tube before the final seal. A layout of each of the elements is shown in Figure 5.1-1. The processing was designed to process both the primary and second stage photocathodes at the same time. The second stage photocathode was formed on the underside of the center fiber optic. This was supported on top of the pod in the transfer fixture. The transfer fixture held the center fiber optic in three small spring fingers set at the end of a spring loaded plunger. After the photocathode process the transfer fixture containing the fiber optic was transferred into the tube body. Using a two prong fork-shaped arm inserted in the wall of the chamber through a bellows, the spring loaded plunger was pushed down. This simple step effected a permanent transfer of the center fiber optic into the tube body after which the fixture could be easily withdrawn. A second place was made in the top plate of the processing pod to support the input or first stage photocathode. This faceplate was held in a holder allowing easy pickup and transfer to the top of the tube body for final seal. The pickup and transfer of both photocathodes was done with an arm supported through the wall of the chamber on a flexible bellows. As shown in figure 5.1-1 the tube body was supported from the copper top plate by the indium heater assembly. This heater was made so that the heat would only be conducted into the copper top plate. The bottom part of the heater contained a shield to keep the heat off the rest of the tube body. The center photocathode, which was already in place in the tube body, was then protected from heat during the final photocathode seal. A weight was added to the bottom of the tube body which gave it more support during the center fiber optic transfer operation. In order to determine both the cosmetic quality

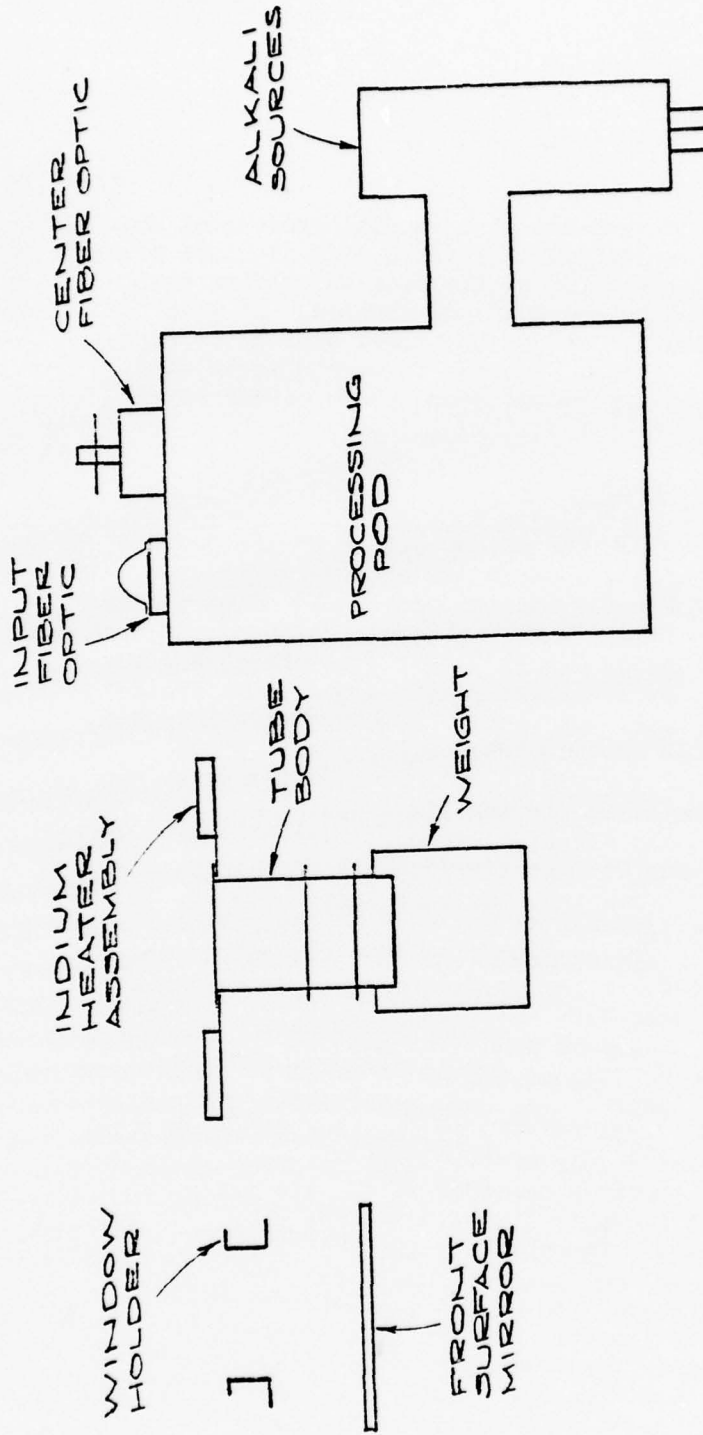

12mm PROCESSING CHAMBER LAYOUT

FIGURE 5.1-1

and sensitivity of the center photocathode a front surface mirror was set up in the processing chamber. Placing the photocathode over the mirror allowed the bottom surface to be viewed and also illuminated with a reflected calibrated light. After illuminating the photocathode a potential could be placed on the mirror to collect emitted electrons from the photocathode. Cross calibration was done by measuring the primary cathode on the mirror first. Since the primary cathode was already accurately measured in the transmission mode, the reflected measurement was used as a comparison for the reflected sensitivity of the center photocathode. This method was found to be very useful in determining the sensitivity of the center photocathode. The difference in sensitivity between the primary and second stage cathodes was usually only a few percent which is to be expected since both cathodes were processed side by side over the same processing pod.

## 5.2 Processing Procedure

Each tube underwent a sequence of events for completing the vacuum processing and making the sealed off tube. The most involved process was for the double diode. Single diodes only required a part of the process. The triple diode did not have to be processed per se since it was mechanically made from two tubes, a single and double diode. Following the bakeout, outgas and photocathode formation the photocathode was measured through the fiber optic faceplate. This measurement was then used to calibrate the reflective measurement made over the front surface mirror on the center photocathode as mentioned in the previous section. After the photocathodes were checked visually and measured, the holder containing the center fiber optic was picked up and placed inside the tube body. The top of the fixture was pressed down locking the center fiber optic into the tube body. The fixture was removed and voltage applied to the tube. Using light reflected into the tube body the output could be observed on a mirror placed in the bottom of the vacuum system. At this point any high voltage problems or serious blemishes could be observed and corrective action taken on whether to complete the rest of the sealing procedure. If the second stage operated well the input faceplate was placed on top of the tube and voltage applied to the complete tube and the output observed using minimal light input to the first stage photocathode. Voltage could be varied on each stage and the general quality of the tube observed before the final seal. If all elements were of acceptable quality, within the limits of what could be observed

in the vacuum system, then the final seal was made. Final sealing of the faceplate was made by activating the indium heater until the photocathode substrate had made a seal to the indium, usually less than 15 or 20 minutes. Following a cooldown period of 2 hours the vacuum chamber was opened up and the tube removed and sent to test.

## SECTION VI

### FINAL TUBE CONFIGURATION

The final tube configurations are shown in figures 6.1-1 and 6.1-2. Both tubes were potted in hard shells with self-aligning input and output caps.

#### 6.1 Double Diode Configuration

Figure 6.1-1 shows the Potted Double Diode. The tube was prepared by attaching leads to the tube's components and placing it into the potting shield. The shield, made of black Delrin, was made to self-align the tube. No special alignment fixtures were needed to pot the tube and maintain concentricity within the housing. After inserting the tube into the housing the potting was poured in and the rear cap put into position. The potting was allowed to cure then the tube was ready for final test.

#### 6.2 Triple Diode Configuration

Figure 6.1-2 shown the Potted Triple Diode. This tube was assembled in a similar way to the double diode. All parts of the potting shield were self aligning for the tubes as in the double diode configuration.

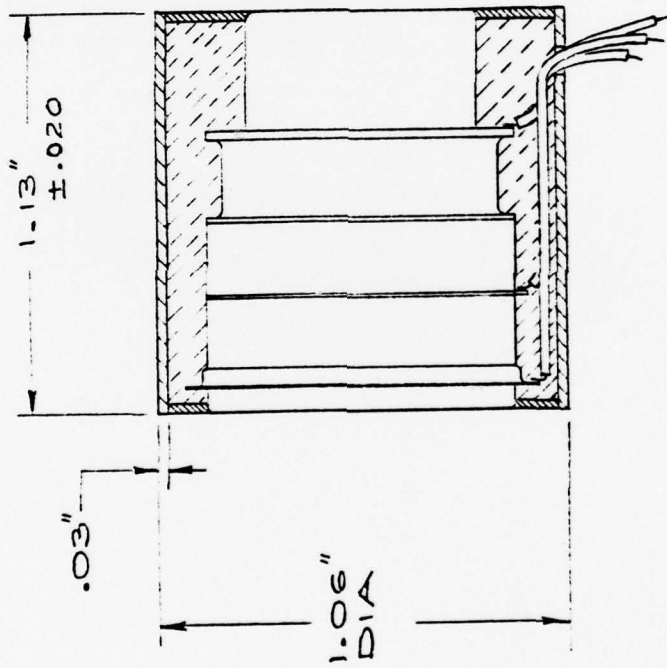

POTTED DOUBLE DIODE

FIGURE 6.1-1

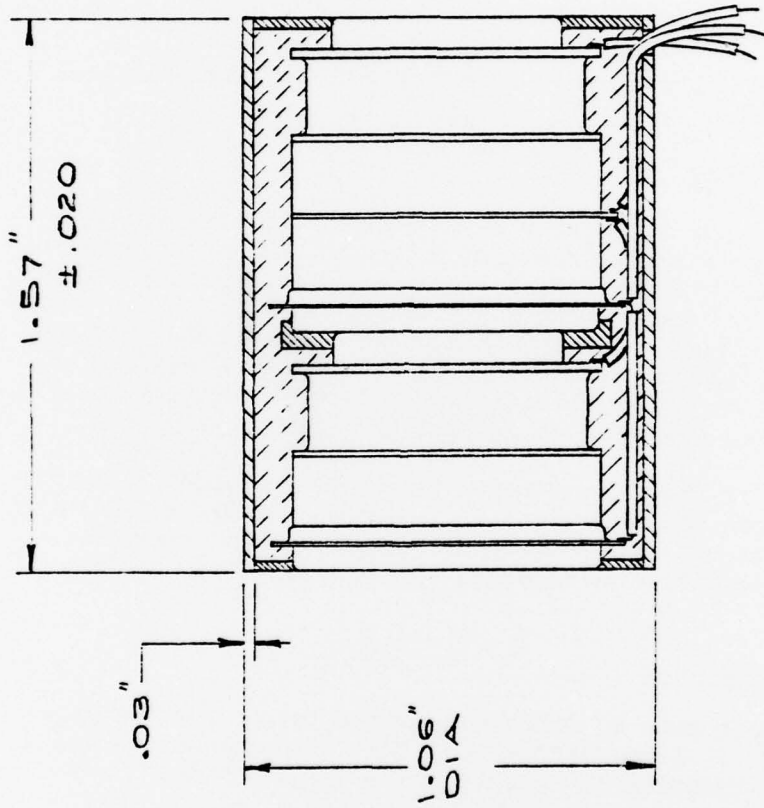

POTTED TRIPLE DIODE

FIGURE 6.1-2

## SECTION VII

### RESULTS

The following section will describe the results of the tube fabrication and test phase of the program. All the devices were made according to the descriptions given in the previous Design, Assembly and Process sections of this report. Methods of test or measurements will be described along with the results in each section.

#### 8.1 Tube starts - Summary

Table 8.1-1 lists each tube start and the final disposition of each tube.

#### 8.2 Photocathodes

The objective photocathode sensitivity for this program was 240  $\mu\text{a/lumen}$  with extended red response. All photocathodes made on this program were measured for sensitivity using a 2854<sup>o</sup>K Color Temperature source with an intensity of .005 lumen. As the data shows in Figure 8.2-1 thirteen photocathodes were measured from the total number of tubes processed. 77% of these or ten were above the objective sensitivity. Of the three tubes below 240 two were above 200 at 236 and 228 respectively.

Not all of the photocathodes made were measured for spectral response because some were lost or rejected. Figure 8.2-2 shows a plot of seven of these photocathodes showing that they were extended red sensitive as compared to a standard S-20 photocathode.

#### 8.3 Brightness Gain

Brightness gain objectives as stated before for the program were 1000 ft-lamberts/ft-candle for the double diode and 7000-10000 ft-lamberts/ft-candle for the triple diode. These levels were to be achieved while maintaining a voltage level of 5 to 7 KV between the photocathodes and phosphors. The attached figures 8.3-1, 8.3-2 and 8.3-3 show the Brightness Gain vs. Voltage for the single, double and triple diodes produced on this program. In all cases the objective gain for the program was met. In fact in most all cases it was not required to run the tube beyond 6.0 KV to achieve this goal. None of these tubes were ever required to be run at 7.0 KV, the maximum voltage proposed, to achieve a gain within the objective goal.

TABLE 8.1-1  
TUBE STARTS AND TUBE DISPOSITION

TUBE NO.	TUBE TYPE	RESULTS	DISPOSITION
DD-253-1	Double Diode	Leak in copper top plate braze.	Could not seal
DD-253-2	Double Diode	126 $\mu\text{a/lumen}$ -Input faceplate chipped during process causing field emission in first stage.	Reject
DD-253-3	Double Diode	High field emission from center fiber optic damaged output phosphor.	Not sealed, salvage tube body.
DD-253-4	Double Diode	Indium-bismuth seal leaked after process.	Recycled tube body.
DD-253-5	Double Diode	268 $\mu\text{a/lumen}$ , Gain-46.5 at 5.0 KV/stage, second stage arced at 5.5 KV/stage.	Tube opened and center phosphor found mottled-poisoned.
DD-253-6	Double Diode	228 $\mu\text{a/lumen}$ , Gain-1000 at 5.7 KV/stage, Resolution-22 lp/mm. Some field emission at turn-on.	Potted as DD-253/1
S-253-7	Single Diode	284 $\mu\text{a/lumen}$ , Gain-110 at 6.5 KV, Resolution 55 lp/mm.	Used for Triple Diode T-253/1
S-253-8	Single Diode	346 $\mu\text{a/lumen}$ , Gain-140 at 6.0 KV, Resolution-55 lp/mm.	Used for Triple Diode T-253/2
DD-253-9	Double Diode	Tube not sealed due to emission point from center fiber optic in second stage.	Tube body salvaged
DD-253-10	Double Diode	246 $\mu\text{a/lumen}$ , Gain-2000 at 5.3 KV, Resolution-22 lp/mm.	Potted as DD-253/2
DD-253-11-T	Double Diode for triple Diode	294 $\mu\text{a/lumen}$ , Gain-5000 at 5.0 KV, Resolution-22 lp/mm.	Potted with S-253-7 as T-253/1. Some field emission when turned on.
DD-253-12	Double Diode	330 $\mu\text{a/lumen}$ , Gain-1300 at 5.0 KV, Some emission points at 5.0 KV.	Tube dropped during potting and dislogged center fiber optic.
DD-253-13-T	Double Diode for triple Diode	236 $\mu\text{a/lumen}$ , Gain-1800 at 6.0 KV.	Potted with S-253-8 as T-253/2

TABLE 8.1-1 (Cont'd)  
TUBE STARTS AND TUBE DISPOSITION

TUBE NO.	TUBE TYPE	RESULTS	DISPOSITION
DD-253-14-T	Double Diode for triple Diode	264 $\mu$ a/lumen, Internal breakdown black spots and edge glow	Rejected
DD-253-15	Double Diode	Center fiber optic would not become seated after transfer.	Seal not completed tube body salvaged
DD-253-16	Double Diode	270 $\mu$ a/lumen, Gain-1900 at 6.0 KV, Some field emission.	Leaked after potting
DD-253-17	Double Diode	Tube leaked after removal from vacuum system - Leak check found leak in copper top plate and ceramic braze.	Reject
DD-253-18	Double Diode	400 $\mu$ a/lumen - Excessive arcing in front end at 4.0 KV. Gain at 3.5 KV-520. Tube leaked to air. Small leak found in copper top plate and ceramic braze.	Reject
DD-253-19	Double Diode	272 $\mu$ a/lumen - Gain-2000 at 5.7 KV One bright spot. Leaked to air after cleaning for potting.	Reject

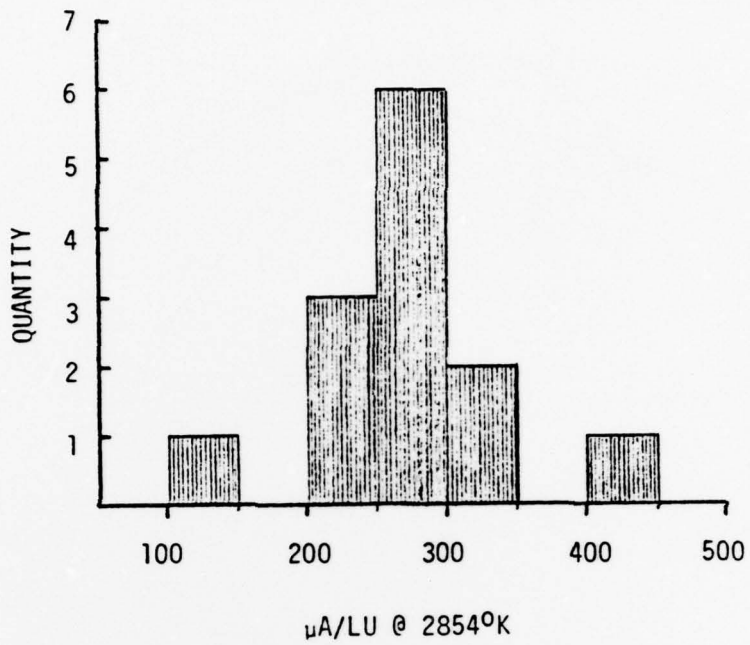

GOAL SPECIFICATION - 240  $\mu\text{A/LU}$   
 ABOVE 240 - 10 TUBES  
 BELOW 240 - 3 TUBES  
 AVERAGE - 274  $\mu\text{A/LU}$   
 STD. DEV. - 62.7  $\mu\text{A/LU}$   
 RANGE - 126 TO 420  $\mu\text{A/LU}$

12 MM DOUBLE DIODE PHOTOCATHODE SENSITIVITY  
 $\mu\text{A/LU}$  @ 2854°K

FIGURE 8.2-1

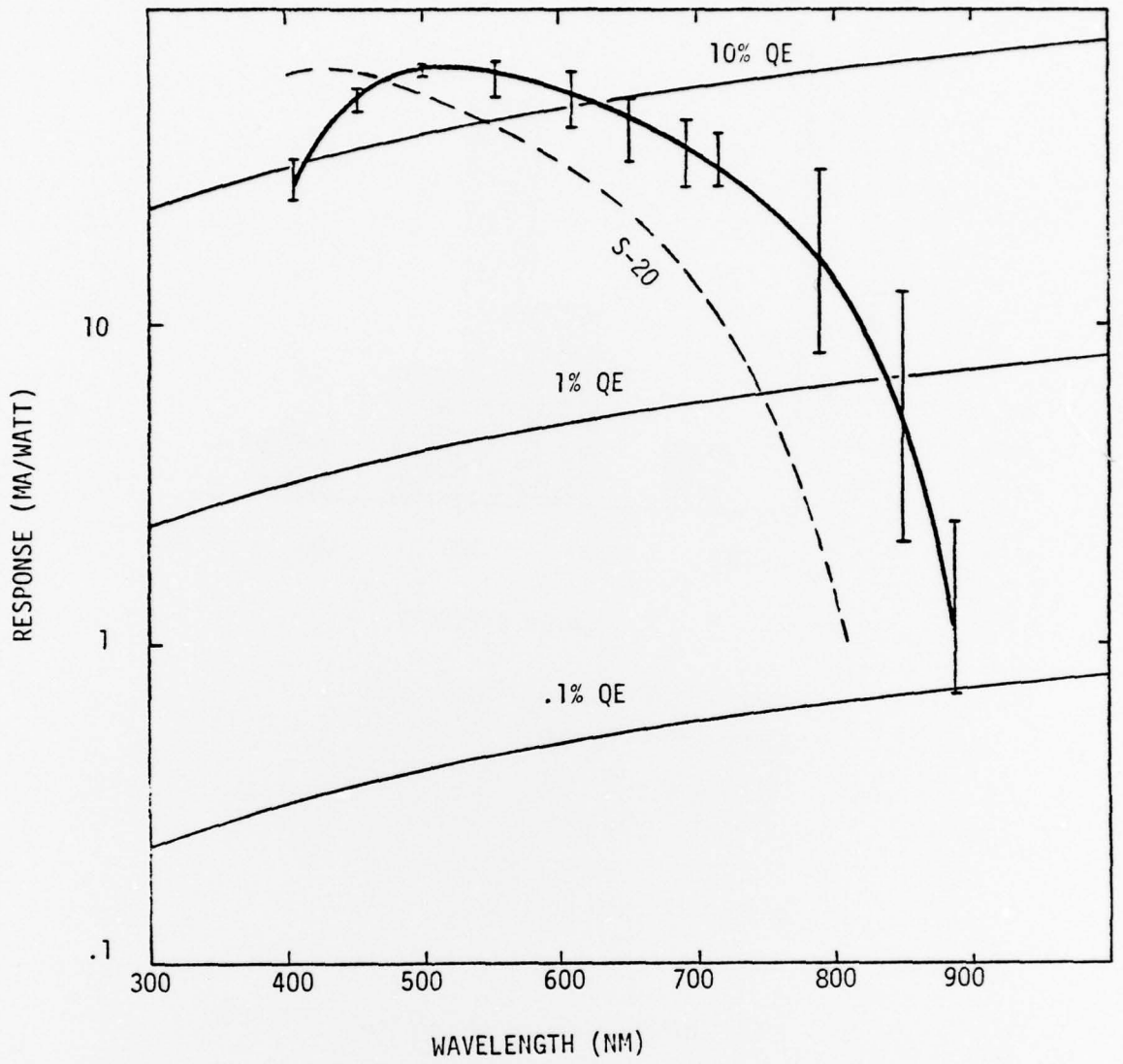

7 SAMPLES EACH POINT

RANGE INDICATED FOR MEASUREMENTS TAKEN AT EACH WAVELENGTH

MEAN SPECTRAL RESPONSE  
12 MM DOUBLE DIODE

FIGURE 8.2-2

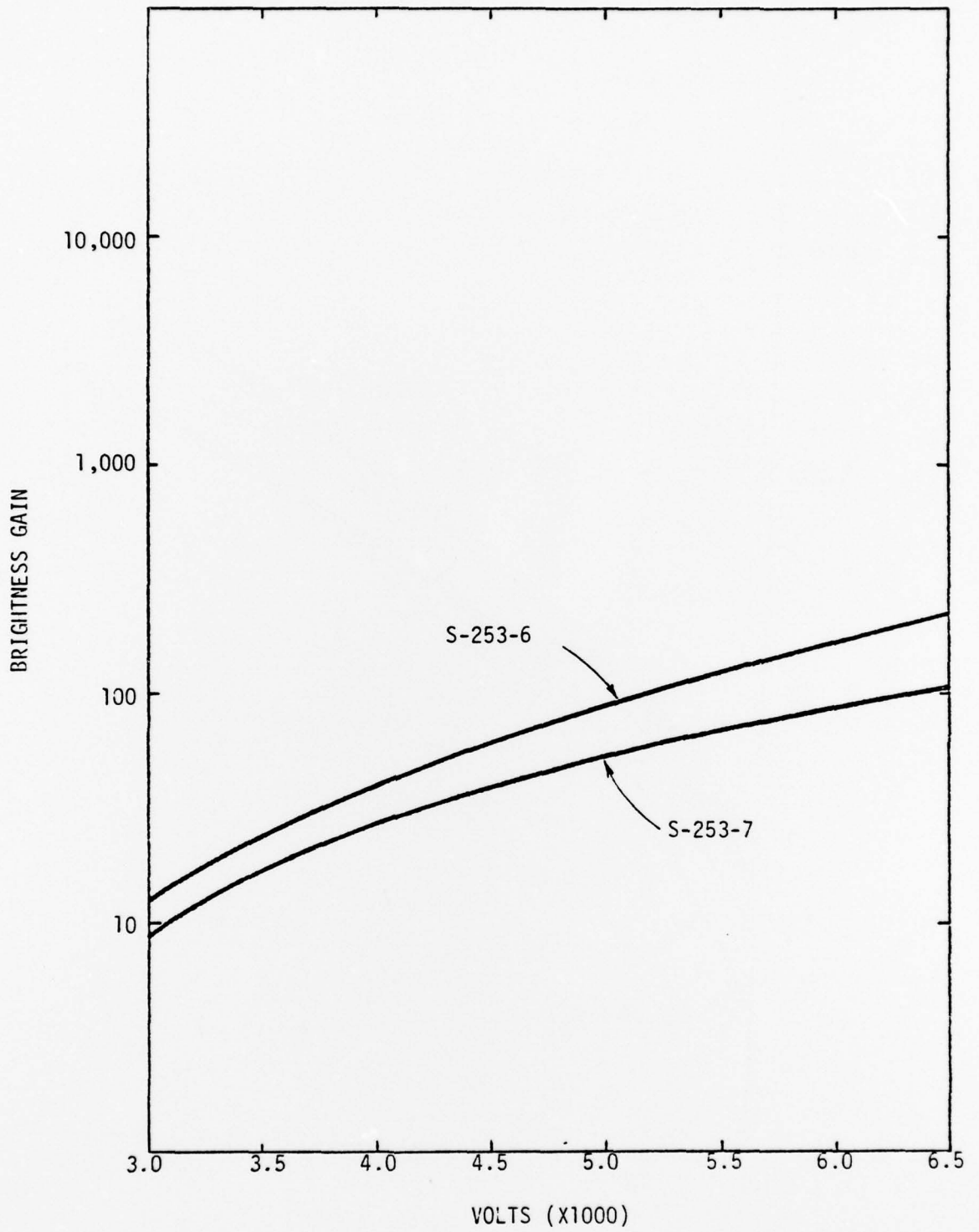

12 MM SINGLE DIODE  
BRIGHTNESS GAIN VS. VOLTAGE

FIGURE 8.3-1

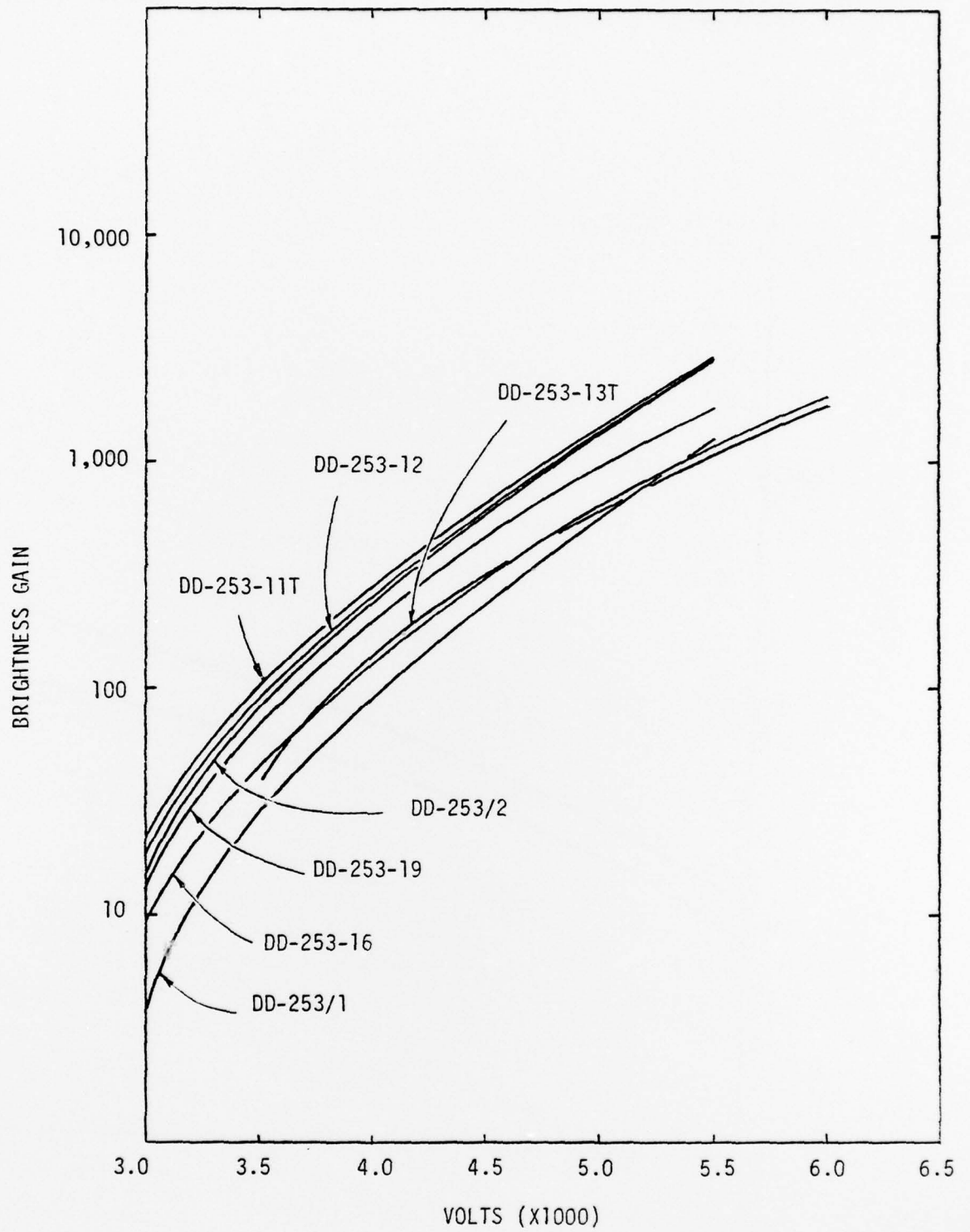

12 MM DOUBLE DIODE  
BRIGHTNESS GAIN VS. VOLTAGE

FIGURE 8.3-2

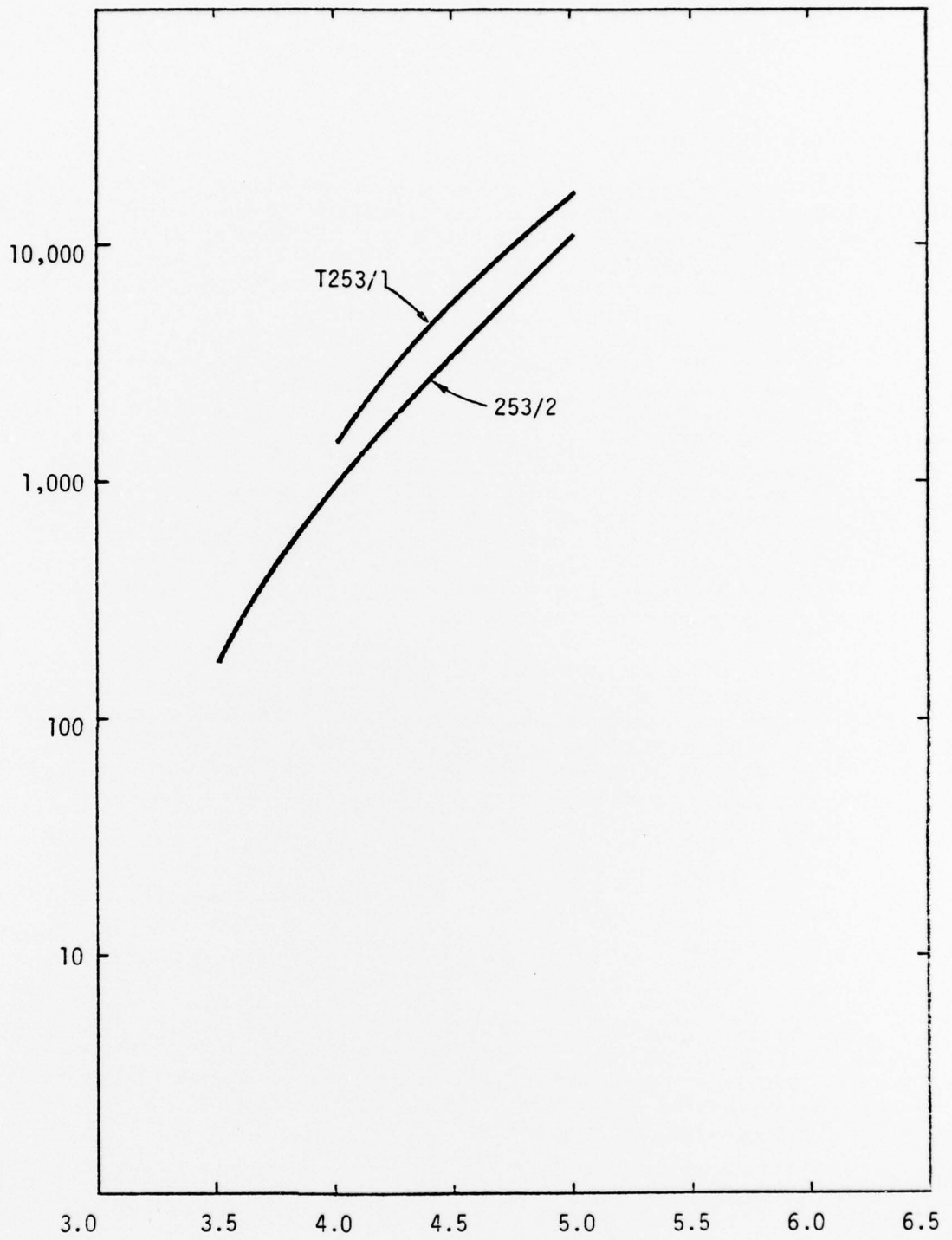

12 MM TRIPLE DIODE  
 BRIGHTNESS GAIN VS. VOLTAGE

FIGURE 8.3-3

#### 8.4 Resolution

Resolution of the double diodes was measured at 22 and 24 lp/mm. The latter was achieved on the tubes made toward the end of the program. The original design called for the spacing to be 1.7 mm (.065") in the first stage and 1.60 (.062") in the second stage. In some of the earlier tubes there was a .005" reduction in the height of the center phosphor capture ring. This moved the plate .005" further away from the photocathode causing the resolution to fall off in the first stage of the tube. The spacings in the first tubes were 1.8 mm (.070") for the first stage and 1.4 mm (.057") for the second stage. Figure 8.4-1 shows that the calculated resolution of these first tubes is 23 lp/mm using these spacings. Actual measurements were 22<sup>+</sup> lp/mm. In tubes made after DD-253-12, the center support ring in the tube body was reversed. This reversed the .005" step in the part raising the center fiber optic .005" resulting in a correction of the .005" drop. Calculated resolution for these tubes was 24 lp/mm. Measurements of these tubes showed 25 lp/mm at 5 KV. Figure 8.4-1 points out these results.

It was not possible to operate too many of these devices above 5 to 5.5KV because of some sporadic field emission problems. Brightness gain requirements were easily achieved at this voltage, which eliminated the need for higher voltage to achieve higher gain. In order to achieve a resultant resolution of 40 lp/mm each stage would have to be capable of 57 lp/mm at 5.5KV. This is shown as follows:

$$\text{Where } \frac{1}{R_T^2} = \frac{1}{R_1^2} + \frac{1}{R_2^2} \quad \text{and } R_1 = R_2 = 57$$

$$\text{then } \frac{1}{R_T^2} = \frac{1}{(57)^2} \quad \text{and } R_T = 40 \text{ lp/mm.}$$

This would require a spacing of 1.0 mm in each stage. The present design of the tube would not support this field gradient. Further modifications of the tube design to accept this change could not be carried out within the time schedule and the funds allocated for this program.

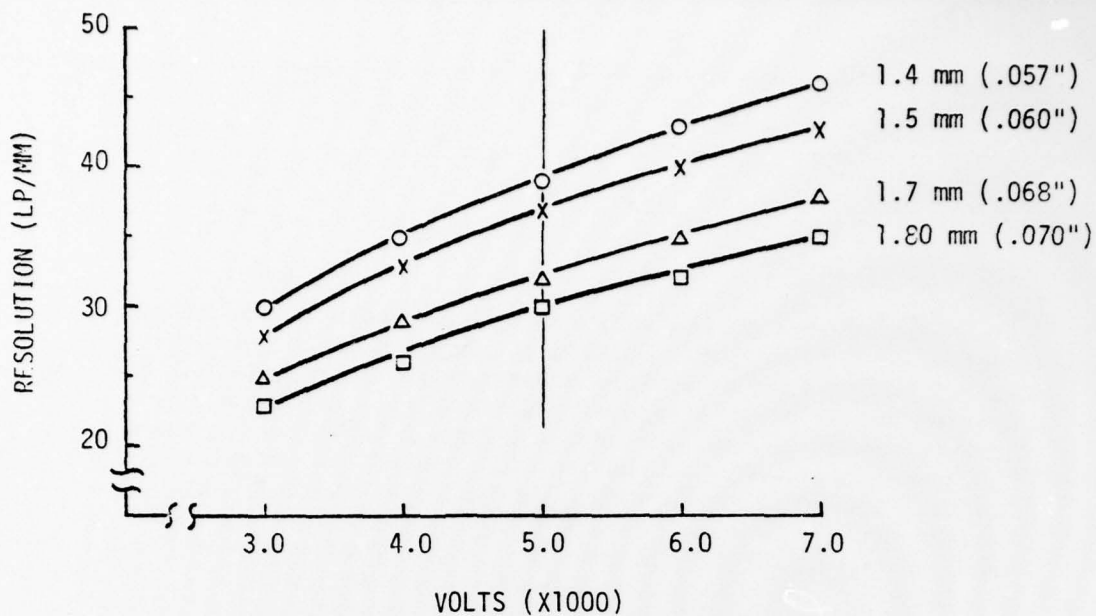

BASIC RELATIONSHIP  $\frac{1}{R_T^2} = \frac{1}{R_1^2} + \frac{1}{R_2^2}$

WHERE  $R_T$  IS RESOLUTION OF TUBE

$R_1$  IS RESOLUTION OF STAGE 1

AND  $R_2$  IS RESOLUTION OF STAGE 2

\* FIRST TUBES - SPACING 1ST STAGE - 1.80 MM  
AT 5KV 2ND STAGE - 1.4 MM

$$\frac{1}{R_T^2} = \frac{1}{(30)^2} + \frac{1}{(39)^2} \quad R_T = 23 \text{ LP/MM}$$

MEASURED - 22<sup>+</sup> LP/MM

\*\* AFTER MODIFICATION - SPACING 1ST STAGE - 1.7 MM  
2ND STAGE - 1.6 MM

$$\frac{1}{R_T^2} = \frac{1}{(32)^2} + \frac{1}{(37)^2} \quad R_T = 24 \text{ LP/MM}$$

MEASURED - 25 LP/MM

12 MM DOUBLE DIODE  
RESOLUTION VS. VOLTAGE AT VARIOUS SPACINGS

FIGURE 8.4-1

### 8.5 Power Supply

All power supplies were received as shown in the design section of this report. No alterations or changes were required to get them to perform as designed. They contained a setting unique to this type of power supply. It was an adjustment which allowed the output phosphor to be set so that the tube would remain on when the ABC (Automatic Brightness Control) turned the tube down. Setting this point or clamp voltage usually at about 2-3 KV achieved good results. The ABC limit on all tubes was set for 1 ft-lambert output maximum. The triple diode used the same power supply design as the double diode without any problems thus limiting the overall voltage to + and - 5 to 6 KV as required. Each power supply was equipped with adjustments for the voltage on each stage, ABC limit and output clamp voltage. Each one was easily adjusted and no problems were encountered in their use.

### 8.6 Items Delivered

As a result of this program two double diodes were delivered to NVL with matching power supplies. The tube serial numbers were DD-2531, and DD-253/2. Also delivered to NVL were two triple diodes whose serial numbers were T-253/1 and T-253/2 and matching power supplies. A fifth power supply was also delivered as a spare. Operational characteristics of these delivered tubes have been discussed in the previous sections of this report. These data may be found by checking for the above serial numbers in the graphs and charts.

### 8.7 Problems

No major problems were encountered with the design or fabrication of these tubes. Only three minor problems had to be dealt with during the execution of the program. These were field emission, the shape of the center locking spring and marginal ceramic metalizing. Field emission occurred in several tubes between the center phosphor/photocathode and the output phosphor. Careful attention to surface finishes on these parts reduced the problem. Changing the center support ring to a complete ring without the present slots should further help eliminate this problem. Most of the center locking springs had to be adjusted by hand. This can be eliminated either by reducing the length of the spring fingers or by replacing the inconel spring with a preformed beryllium copper

unit made from thinner material. Careful attention has to be paid to the amount and condition of the ceramic metalizing. The ceramic body is very thin, only .060", and this thin surface reduces the tolerance for metalization back in from the edges and requires a very uniform coating on the ends. Unlike larger area ceramics where a greater distance can be tolerated from the edge of the ceramic to the metalizing these thin wall ceramics must be more completely covered and the width of the metalizing carefully controlled. In some cases these ceramics caused leaks in tube bodies and weak brazes.

There are solutions for these problems as discussed above which will eliminate the reasons for either not achieving a completed tube or rejecting it later.

## SECTION IX

### CONCLUSIONS AND RECOMMENDATIONS

One of the most important conclusions reached from this program is that the double diode and triple diode image intensifiers are a workable and viable concept for intermediate range requirements using image intensifiers. The concept has been brought down to the practical level. All of the previous design theory has been achieved and exceeded. In most cases the results show the resulting tube performs better than was expected. It has been shown that brightness gains of 2000 and up to 5000 can be achieved on the double diode. The capability of the triple diode to achieve gains of 10,000 and better has also been demonstrated. Only some minor corrections remain to be made on a few of the parts as they exist in order to increase the reliability. With these corrections there is no reason not to believe that the tubes could not be produced on a low cost basis.

The execution of this program has obviously proved the approach to making a lower cost image intensifier with high performance is possible. It can be recommended that the minor changes in design discussed in this report will achieve this goal. No major design changes are recommended or needed. It is recommended that this tube design be seriously considered as the tube which closes the gap in image intensification. The device provides for mid range requirements below that provided by tubes with microchannel plates and above the area covered by simple diode intensifiers.