

AD-A062 761

HUGHES AIRCRAFT CO CULVER CITY CALIF DISPLAY SYSTEMS LAB F/G 20/6
BINOCULAR HOLOGRAPHIC HELMET MOUNTED DISPLAY.(U)

DEC 78 R E HEINEMAN, L W BRADFORD

N62269-77-C-0504

UNCLASSIFIED

HAC-P78-538

NADC-77228-30

NL

| OF |

AD
A062761



END
DATE
FILMED
3-79
DDC

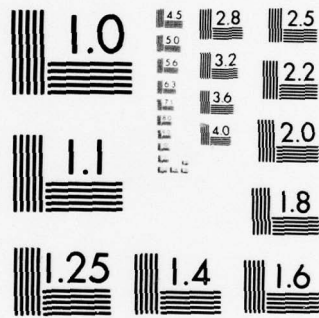

MICROCOPY RESOLUTION TEST CHART
NATIONAL BUREAU OF STANDARDS-1963-A

AD A062761

DDC FILE COPY

NADC-77228-30
Contract No. N62269-77-C-0504

✓ (12) ~~SECRET~~ #

BINOCULAR HOLOGRAPHIC HELMET-MOUNTED DISPLAY

Display Systems Laboratory
Hughes Aircraft Company
Centinela & Teale Streets
Culver City, California 90230

December 1978

Final Technical Report for Period October 1977 - September 1978

Approved for public release,
distribution unlimited.

DDC
RECEIVED
JAN 3 1979
A

Prepared for:

Naval Air Development Center
Warminster, Pennsylvania 18974

79 01 03 026

NOTICE

When Government drawings, specifications, or other data are used for any purpose other than in connection with a definitely related Government procurement operation, the United States Government thereby incurs no responsibility nor any obligation whatsoever; and the fact that the government may have formulated, furnished, or in any way supplied the said drawings, specifications, or other data, is not to be regarded by implication or otherwise as in any manner licensing the holder or any other person or corporation, or conveying any rights or permission to manufacture, use, or sell any patented invention that may in any way be related thereto.

Copies of this report should not be returned unless return is required by security considerations, contractual obligations, or notice on a specific document.

UNCLASSIFIED

SECURITY CLASSIFICATION OF THIS PAGE (When Data Entered)

REPORT DOCUMENTATION PAGE		READ INSTRUCTIONS BEFORE COMPLETING FORM
1. REPORT NUMBER 18 NADC/77228-30	2. GOVT ACCESSION NO. 19 77228-307	3. RECIPIENT'S CATALOG NUMBER
4. TITLE (and Subtitle) 6 BINOCULAR HOLOGRAPHIC HELMET MOUNTED DISPLAY	5. TYPE OF REPORT & PERIOD COVERED 9 Final Technical Report Oct. 1977 - Sept. 1978	6. PERFORMING ORG. REPORT NUMBER P78-538; E1639
7. AUTHOR(s) 10 R. E. Heineman, L. W. Bradford R. A. Lohmann	8. CONTRACT OR GRANT NUMBER(s) 15 N62269-77-C-0504	10. PROGRAM ELEMENT, PROJECT, TASK AREA & WORK UNIT NUMBERS
9. PERFORMING ORGANIZATION NAME AND ADDRESS Hughes Aircraft Company Centinela & Teale Streets Culver City, California 90230	11. CONTROLLING OFFICE NAME AND ADDRESS Naval Air Development Center Warminster, Pennsylvania 18974 Code - NADC 3042	12. REPORT DATE 11 December 1978
14. MONITORING AGENCY NAME & ADDRESS (if different from Controlling Office)	15. SECURITY CLASS. (of this report) Unclassified	13. NUMBER OF PAGES 55
16. DISTRIBUTION STATEMENT (of this Report) Approved for public release; distribution unlimited. 12 67p		15a. DECLASSIFICATION/DOWNGRADING SCHEDULE
17. DISTRIBUTION STATEMENT (of the abstract entered in Block 20, if different from Report) 14 HAC-P78-538, HAC-REF-E1639		
18. SUPPLEMENTARY NOTES		
19. KEY WORDS (Continue on reverse side if necessary and identify by block number) Diffraction Optics Helmet Mounted Display		
20. ABSTRACT (Continue on reverse side if necessary and identify by block number) This report describes the application of diffraction optics to the design of a helmet mounted display which permits binocular viewing of a dual fiber optics image source. 409 205		

ADDITIONAL	
RTS	Serial Section <input checked="" type="checkbox"/>
DCS	Dist Section <input type="checkbox"/>
NO. ENDOCES	<input type="checkbox"/>
JUSTIFICATION	
BY	
DISTRIBUTION/AVAILABILITY CODES	
INT.	AVAIL. NO. OF SPECIAL
A	

CONTENTS

1.0	INTRODUCTION	1-1
1.1	Program Task	1-1
1.2	Report Organization	1-1
2.0	SUMMARY	2-1
2.1	Program Requirements	2-1
2.2	Program Steps	2-1
2.2.1	Preliminary	2-1
2.2.2	Hologram Fabrication	2-2
2.2.3	Final Design	2-2
3.0	DETAIL TRADEOFFS AND ANALYSIS	3-1
3.1	Detail Requirements	3-1
3.1.1	Optical Requirements	3-1
3.1.2	Physical Requirements	3-1
3.2	Design Tradeoffs	3-2
3.2.1	Optical Tradeoffs	3-2
3.2.2	Physical Tradeoffs	3-11
4.0	BHHD OPTICAL DESIGN	4-1
4.1	Optical Design Summary	4-1
4.2	Optical Design of the BHHD	4-2
4.2.1	System Considerations	4-2
4.2.2	Holographic Lens Design	4-3
4.2.3	Relay Optics	4-3
4.3	BHHD Performance	4-8

CONTENTS (Continued)

5.0	PHYSICAL DESIGN	5-1
5.1	Visor Mounting Design	5-1
5.2	Relay Optics Mounting	5-4
5.3	Relay Optics Housing	5-4
5.4	Fiber Light Pipe Termination	5-5
5.5	Weight and C. G. Analysis	5-5
5.6	Alignment Methods	5-7
5.6.1	Combiners and Relay Optics Mounted to Visor	5-7
5.6.2	Bracket-Held Holograms Independent of Visor	5-9
6.0	FABRICATION TECHNIQUES	6-1
6.1	Diffraction Lens	6-1
6.1.1	Construction Optics Setup	6-2
6.1.2	Alignment of Setup	6-2
6.1.3	Holographic Process	6-2
6.2	Relay Optics Housing	6-4
7.0	WIDE FIELD OF VIEW DESIGN	7-1
7.1	Wide Field of View Requirements	7-1
7.2	Optical Considerations	7-1
7.3	Physical Design Considerations	7-3
8.0	CONCLUSIONS	8-1
8.1	Accomplishments	8-1
8.1.1	Optical Design Accomplishments	8-1
8.1.2	Physical Design Accomplishments	8-2
8.1.3	Hologram Fabrication Development	8-2
8.2	Recommendations for Future Program	8-3

LIST OF ILLUSTRATIONS

Figure		Page
2-1	Binocular Holographic Helmet Display	2-3
3-1	Relayless Symmetrical System	3-3
3-2	Maximum Exit Pupil Diameter Versus Eye Relief	3-4
3-3	Efficiency Versus Exit Pupil, Vertical Field Angle for Relayless System	3-5
3-4	Efficiency Versus Exit Pupil, Horizontal Field Angle for Relayless System	3-6
3-5	Aberrations Versus Exit Pupil for Relayless System	3-7
3-6	Asymmetrical Relayed System. Light Pipe Around Sides of Helmet	3-9
3-7	Hologram Geometry Definitions	3-10
3-8	Relay Optics Folded to Side of Head	3-12
3-9	Crossed-path Optics Design	3-15
4-1	BHHD Relay Assembly (Preliminary Configuration)	4-1
4-2	Optical Schematic of BHHD Elements	4-4
4-3	Side View of BHHD Elements	4-5
4-4	Front View of BHHD Elements	4-6
4-5	Top View of BHHD Elements	4-7
4-6	Orientation of Image at Fiber Bundle	4-9
4-7	BHHD Angular Errors Across Pupil	4-10
4-8	Ray Aberration Curves for Vertical FOV	4-11
4-9	Ray Aberration Curves for Horizontal FOV	4-12
4-10	BHHD MTF Curves	4-14

LIST OF ILLUSTRATIONS (Continued)

Figure		Page
4-11	Map of Distortion	4-13
5-1	BHHD Layout	5-2
5-2	Optics/Vision Mounting Scheme	5-3
5-3	Combiners and Optics Mounted to Visor	5-8
5-4	Holograms Supported by Bracket Frame	5-10
6-1	Construction Optics	6-3
7-1	Computer Raytrace of Unfolded, Feasibility Model One-Tube Goggle Optical System	7-4
7-2	Preliminary Wide FOV Layout	7-5
7-3	Field of View Schemes	7-6

LIST OF TABLES

Table		Page
3-1	Optical Requirements	3-1
4-1	BHHD Optical Characteristics	4-8
7-1	Comparison of BHHD and HOTG Optical Characteristics . . .	7-2

1.0 INTRODUCTION

1.1 PROGRAM TASK

This report summarizes the effort and accomplishments of a twelve month program to design and develop a Binocular Holographic Helmet Display (BHHD), which permits binocular viewing of a dual image source. The design consists of two diffraction optics collimating eyepieces attached to the visor of a standard Navy flight helmet and two optical relay lens assemblies which transmit the image to the eyepieces. The display source includes a binocularly viewed twin fiber optic light pipe transmitting images from a split screen CRT. The effort also included the fabrication of sample visor diffraction elements.

1.2 REPORT ORGANIZATION

A review of the program requirements and important steps of the program are summarized in Section 2. Section 3 addresses the detail requirements for the BHHD and various analyses and tradeoffs that were performed. Details of the optical design and a discussion of the optical performance are included in Section 4, while Section 5 discusses the physical design of the BHHD. Section 6 discusses fabrication technique. Section 7 presents the recommendations for a wide field of view design. Section 8 presents the conclusions and recommendation for future effort.

2.0 SUMMARY

2.1 PROGRAM REQUIREMENTS

The program has successfully achieved its task of developing a holographic visor which is compatible with a standard Navy helmet and which provides binocular viewing of a dual image source over a 15-degree field of view. Specific optical and physical requirements were addressed to assure satisfactory performance. This included such optical requirements as interpupillary accommodations, field of view, resolution and distortion, and physical requirements relating to alignment, overall weight, environmental conditions and allowable modifications to the standard Navy helmet.

An auxiliary study was performed to evaluate the potential for a wider field of view (WFOV) display. In this study the characteristics of an existing WFOV binocular goggle design were compared with the optical characteristics of the BHHD program. Similarities between the two designs suggested that a wider field of view (40°) was feasible but would require significant changes in the present physical and optical design.

2.2 PROGRAM STEPS

2.2.1 Preliminary

A preliminary optics design of the BHHD was developed prior to the preliminary design review (PDR) conducted with the Navy in January 1978. At this time four concepts and their performance characteristics were reviewed. They are: 1) The relayless, direct viewed symmetrical optical

system, 2) the relayless, direct viewed symmetrical system with corrective optics, 3) a symmetrical system using relay optics and 4) an asymmetrical system using relay optics. It was concluded that, the relay symmetrical system with 12 mm exit pupil, would be pursued to obtain increased optical performance over the other methods. The relayed system also offered less obstruction to the look-up angle but required a physical tilting of the spherical visor design for improved combiner efficiency.

2.2.2 Hologram Fabrication

Fabrication of representative sample holographic combiner optics was initiated using both plastic and glass substrates. Holograms were processed on both types of substrates, thus verifying the technical feasibility of either approach. However, the need to evaluate the stability of the plastic holograms over varying temperature and humidity environments required more extensive testing than feasible under this program. As a result holograms on glass substrates were provided on the BHHD visor, with additional testing of plastic holograms continued at Hughes under separate efforts.

2.2.3 Final Design

The final BHHD design shown in Figure 2-1, incorporates a standard HGU-33 helmet with an oversized visor to be fabricated from 15 percent transmission neutral density polycarbonate material. The holographic combiners are precision mounted to the visor assembly which includes a supportive stiffening frame that is precision mounted to the helmet bracket. Accurate location of the combiners to the visor is accomplished by specialized tooling. Accurate registration of the combiners to the relay optics is provided by precise mounting of the visor and optics to the helmet bracket. The helmet bracket extends from one side of the helmet to the other side supporting the visor and the optics. The dual optics assembly is designed as a single assembly using mirrors for folding the optical paths to accommodate packaging constraints. The optics housing will consist of molded/machined plastic sections bolted together at assembly, providing a rugged dust proof housing.

TA/4747

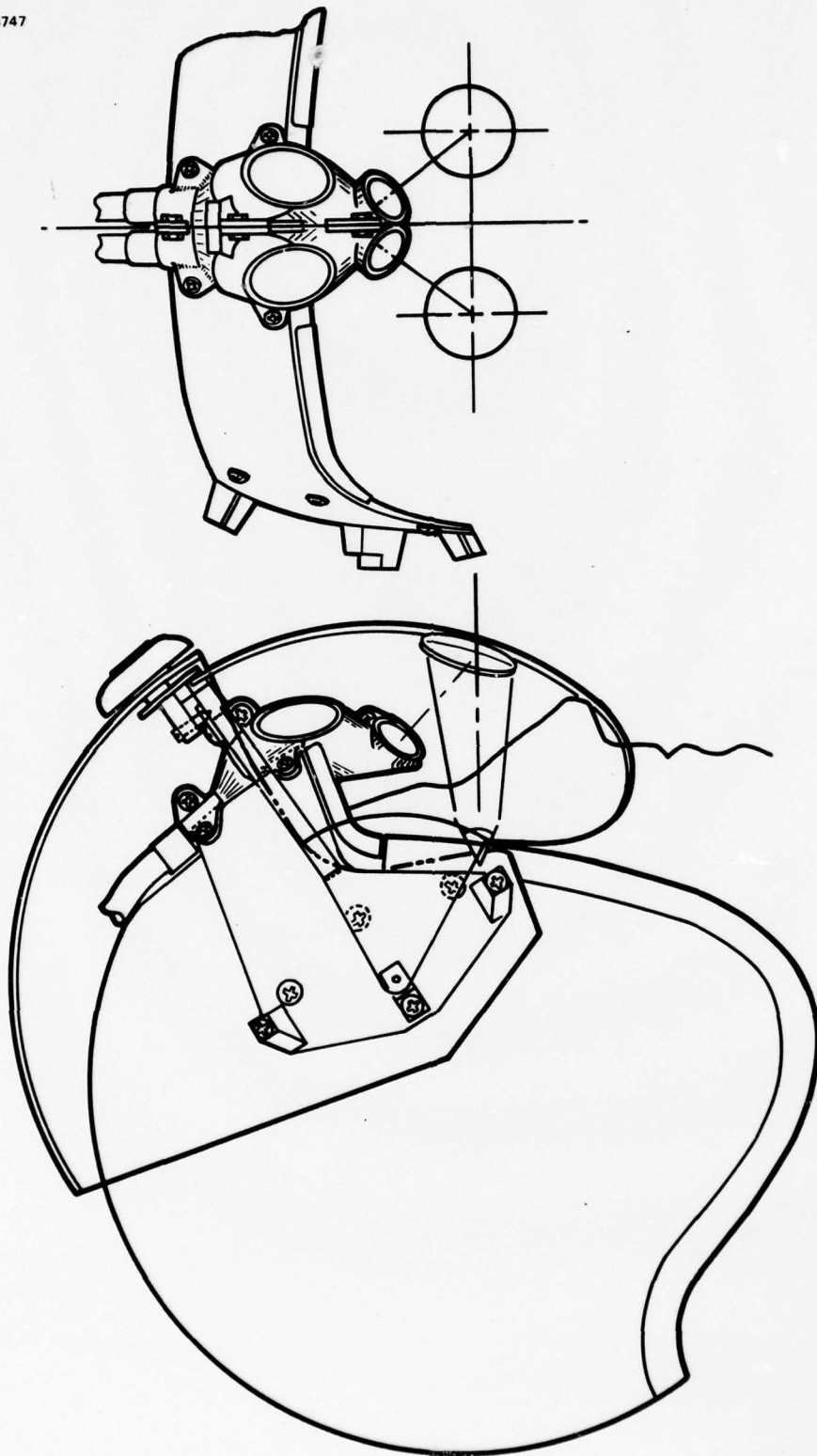

Figure 2-1. Binocular holographic helmet display.

3.0 DETAIL TRADEOFFS AND ANALYSIS

3.1 DETAIL REQUIREMENTS

The BHHD consists of a visor containing two diffraction optical combiners, dual relay optics assembly, two fiber bundle light pipes and the visor/relay optics mounting hardware integrated with a standard HGU-33 flight helmet. The following paragraphs list the optical and physical requirements for design.

3.1.1 Optical Requirements

The detail optical requirements defined by contract specifications are listed in Table 3-1.

3.1.2 Physical Requirements

Detailed physical requirements specified to Hughes are as follows:

1. Design to be compatible with the standard Navy helmet, HGU-33.
2. Display source includes twin fiber optics light pipe; format is 12 mm square picture (12 mm = 15° FOV).
3. The diffraction optics of the visor shall be designed to last at least one half the life cycle of the visor.

TABLE 3-1. OPTICAL REQUIREMENTS

Combiner	Diffraction lens incorporated into normal helmet visor in a continuous manner.
Field of View	15°
Unobstructed Vision*	50° look up angle
Interpupillary spacing	Accommodation of the normal eye spacing (63 mm PD)
Color	Compatible with 543 nm source P-43 phosphor
*Additional requirements	

3.2 DESIGN TRADEOFFS

Developing the design for the BHHD was an interactive process, which required consideration of both the physical and optical configuration. Working with the physical boundaries imposed by the helmet and head, four basic approaches were first analyzed with respect to the optical requirements of resolution and distortion. The four baseline systems are described as follows: 1) relayless, direct viewed symmetrical system, fiber optics face plate as the image plane, 2) relayless, direct viewed symmetrical system with corrective optics between the hologram and the fiber optics face plate, 3) symmetrical system with intermediate image and relay optics, and 4) asymmetrical relay system. The first three systems have the fiber optic light pipe coming over the top of the head, in the fourth system the light pipes were to be located at each side of the operator's head.

3.2.1 Optical Tradeoffs

3.2.1.1 Relayless Symmetrical System

Analysis of the relayless symmetrical system, Figure 3-1 pointed out some basic geometrical constraints related to performance of relayless systems in general. There exists a specific tradeoff between field of view and exit pupil size. This tradeoff is based on the efficiency performance of the diffraction optics element. Efficiency of the reflective element is highly angle dependent and exhibits rapid fall off from its peak value as it deviates from the optimum angle. Typically, the efficiency has dropped to 50 percent of its peak value within a 5 degree cone, centered about the peak.

The implications of this performance characteristics is shown in Figure 3-2. To maintain small angular subtense of the pupil by the hologram, the eye relief distance must be large enough to keep the pupil subtense below 10 degrees. Increasing the eye relief of the visor while maintaining the oxygen mask clearance required forward tilting of the visor. The practical limit of forward tilt for the HGU-33P is about 18 degrees which corresponds to an eye relief of 2.8 inches; this results in an exit pupil of 12 mm (0.48 in.) instead of the desired 15 mm. An eye relief of 3.37 inches would be required to achieve the 15 mm exit pupil. To go beyond 2.8 inches required that a

TA/4038

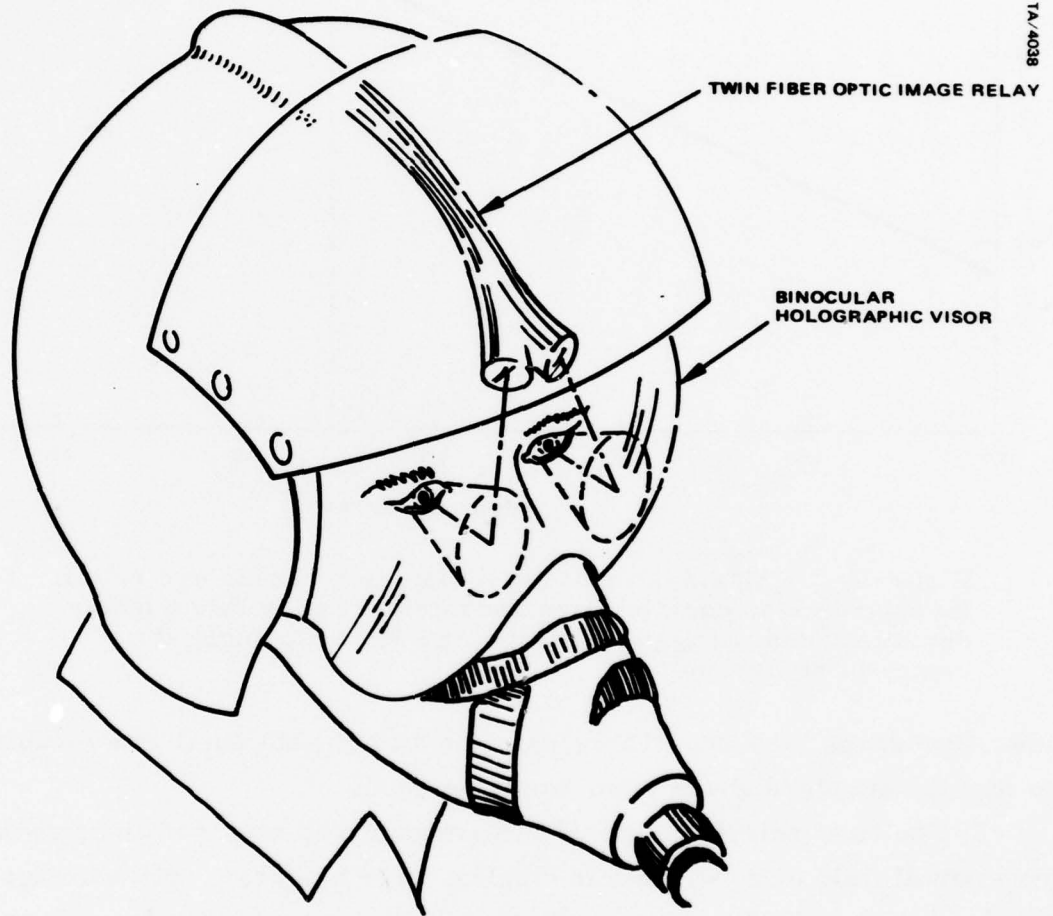
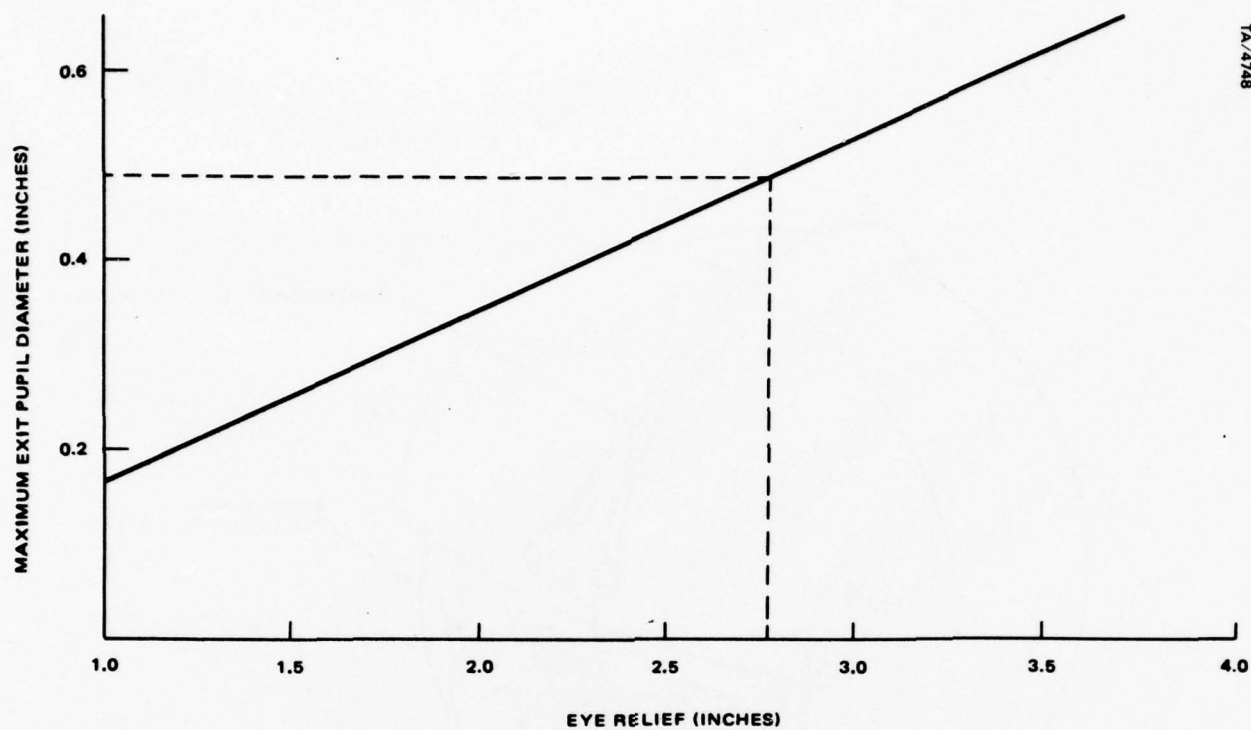

Figure 3-1. Relayless symmetrical system.



TA/4748

Figure 3-2. Maximum exit pupil diameter versus eye relief. (Standard visor configuration assuming 5° allowable angular deviation from Bragg's condition and 45° bend angle at center of hologram.)

new visor shape be used. Therefore, the 12 mm exit pupil was established so that the standard shape visor would be used.

The first relayless optical system analyzed was that being developed for a small field of view, reticle display. The hologram optics design provided a 6 degree FOV, and an exit pupil diameter of 15 mm for reasonable efficiency. Efficiencies and geometrical aberrations were calculated based on existing computer data to show these values for a similar system design with a field of view of 15° . The efficiencies as shown in Figure 3-3 for vertical look-up angles tend to be extremely low. The efficiencies for horizontal field angles as shown in Figure 3-4 are relatively high and acceptable, but based on the vertical efficiencies of this system similar relayless systems could not be tolerated.

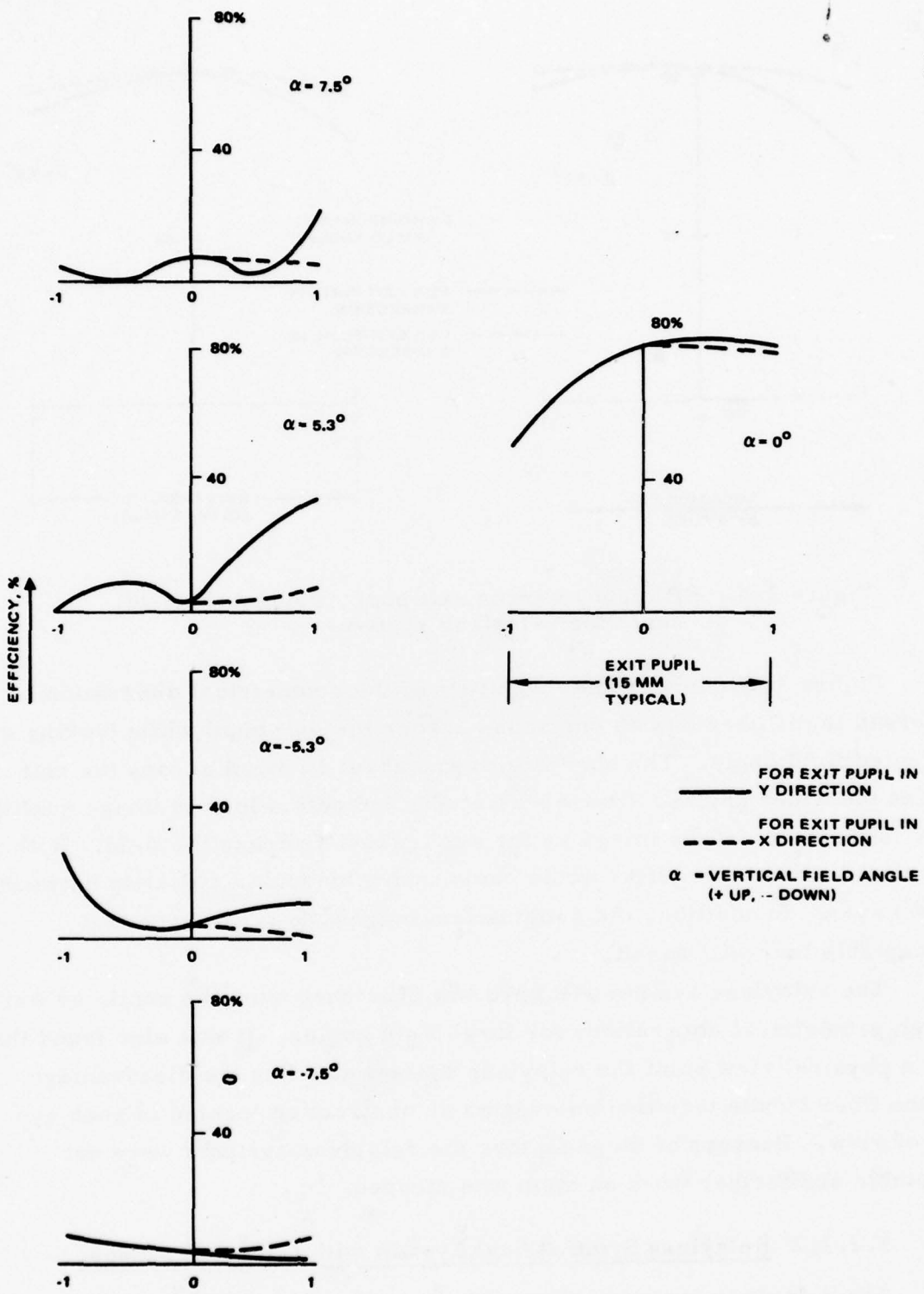

Figure 3-3. Efficiency versus exit pupil, vertical field angle for relayless system.

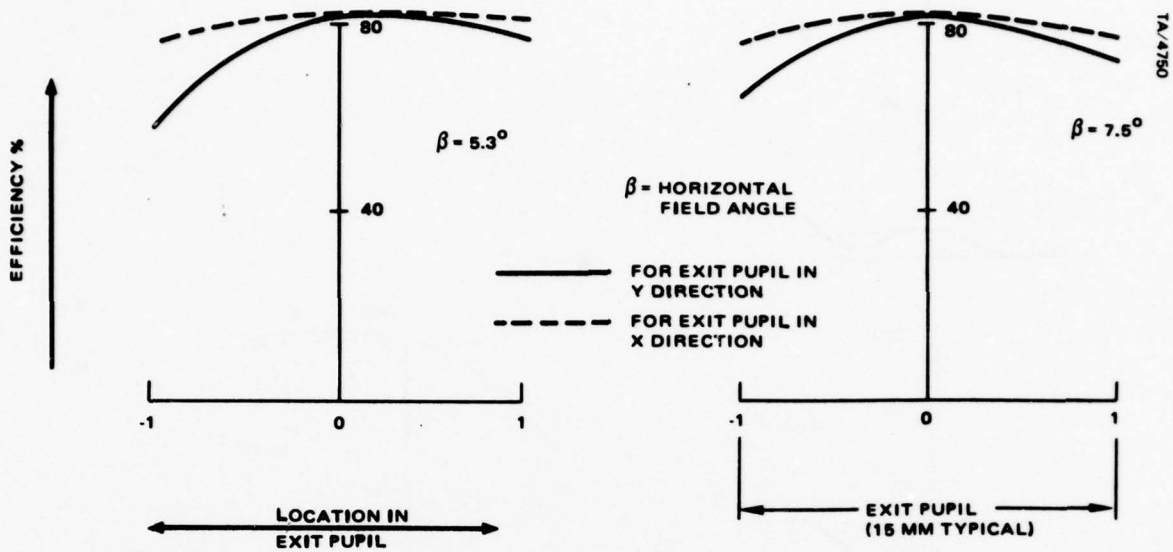

Figure 3-4. Efficiency versus exit pupil, horizontal field angle for relayless system.

Figure 3-5 indicates the magnitude of the geometrical aberration expressed in milliradians as one scans across the exit pupil while looking at a selected field angle. The aberrations are about 10 mrad across the exit pupil at the wider angles. These magnitudes indicate a loss in image quality and a "swimming" of the image as the eye is moved across the field. With a binocular display, this effect would cause undue binocular disparity between the two eyes. In addition, the astigmatism magnitude is so large that unacceptable blur will result.

The relayless system will have low efficiency over the pupil, as well as high geometrical aberrations for large field angles. It was also found that from a physical view point the relayless system also has the disadvantage that the fiber bundle termination creates an obstruction located in each eye field of view. Because of these factors the relayless systems were not acceptable and further work on them was stopped.

3. 2. 1. 2 Relayless Symmetrical System with Corrective Lense

The relayless system with corrective optics between the hologram and the optics face plate would reduce the astigmatism and field curvature

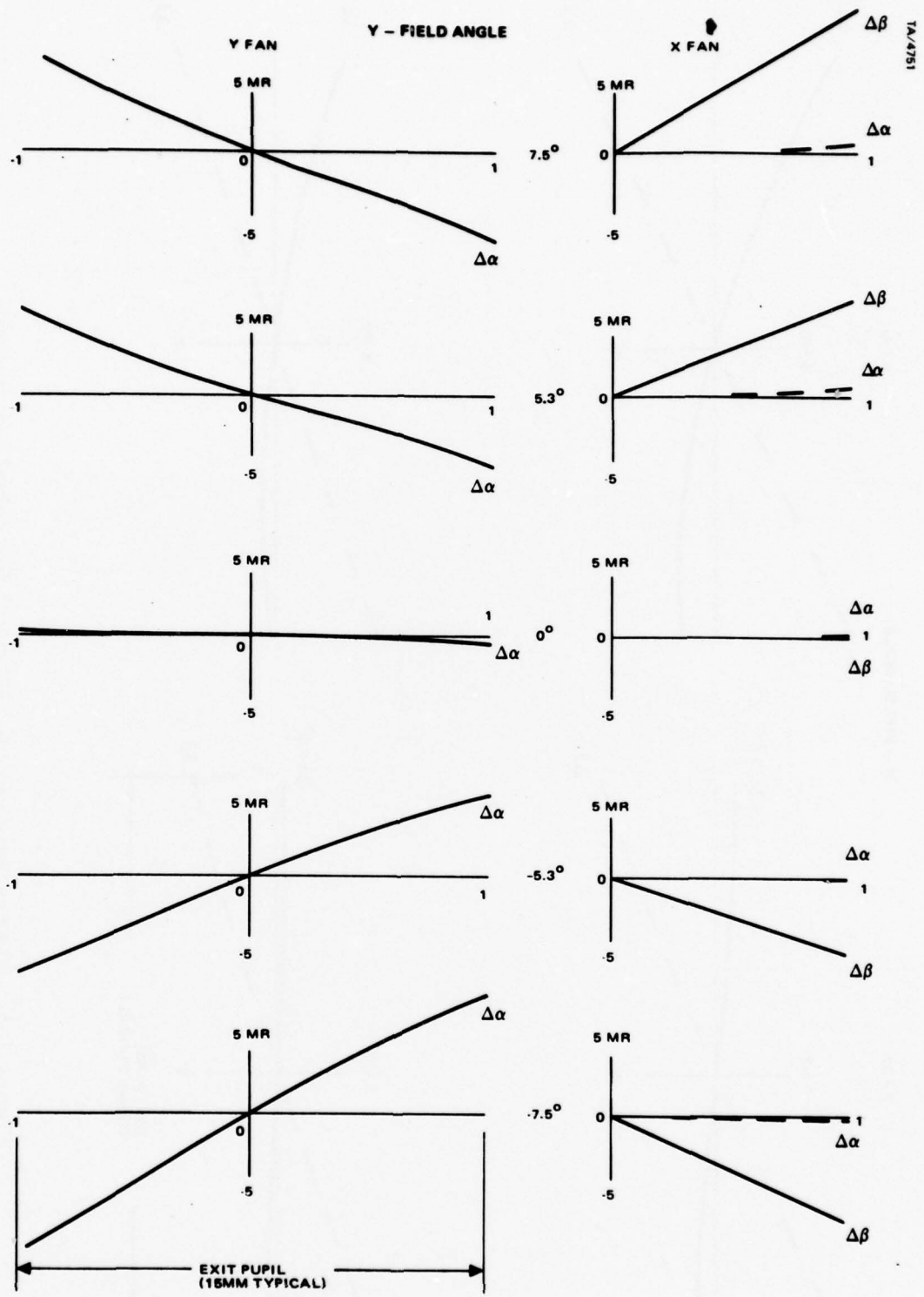

Figure 3-5. Aberrations versus exit pupil for relayless system (Sheet 1 of 2).

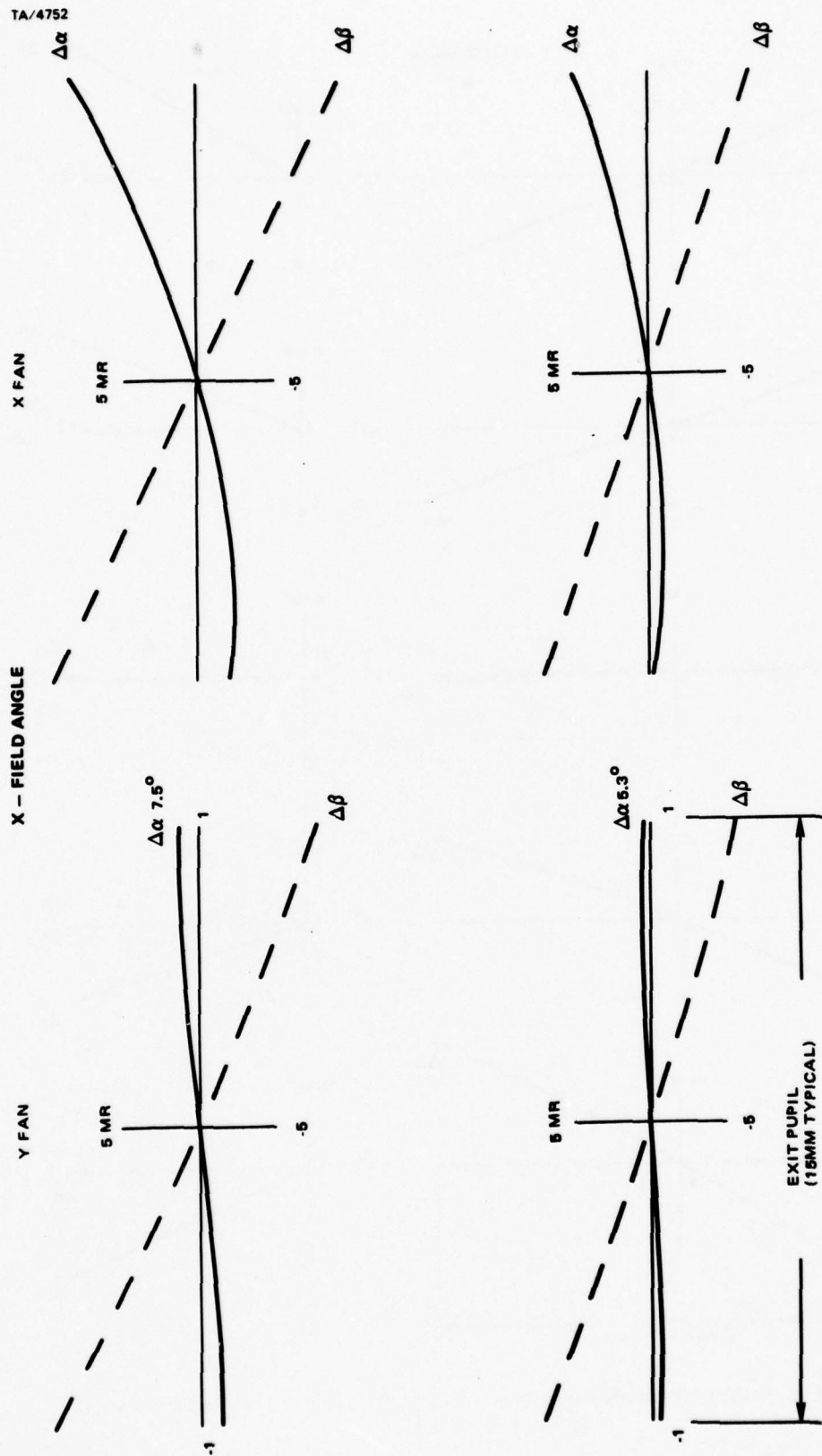
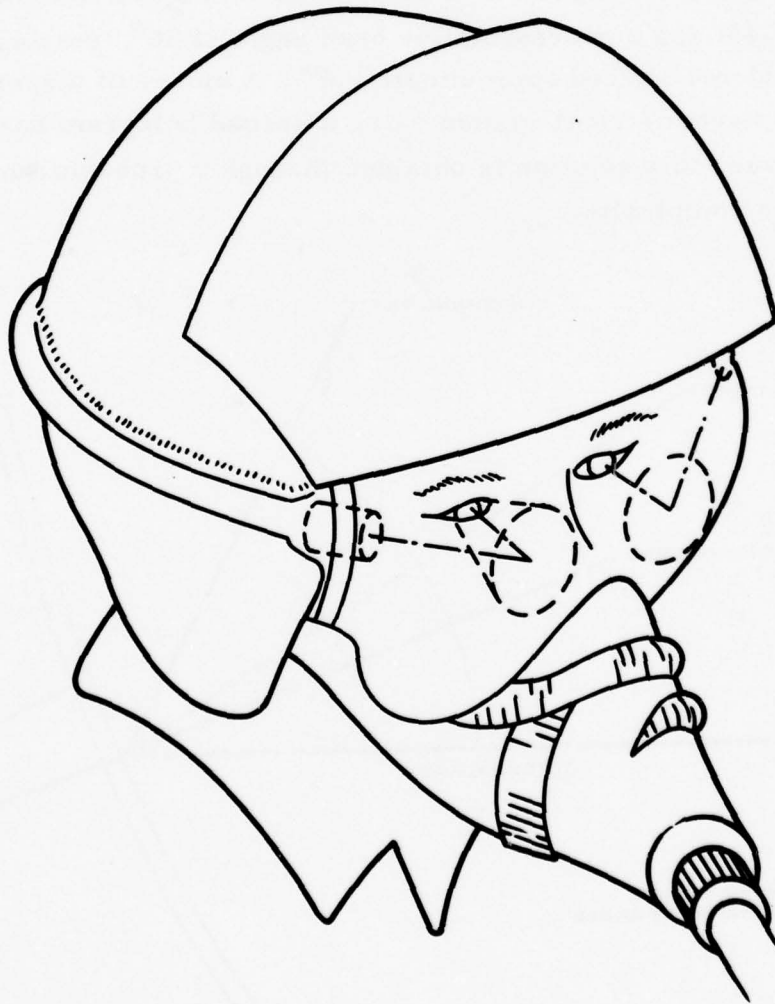

Figure 3-5. Aberrations versus exit pupil for relayless system.
(Sheet 2 of 2).

of the relayless system. Cylindrical and field type lenses would be used. They would not however correct for aberrations that are a function of pupil position and field angle. Also, the placement of the lenses would protrude even further into the field of view space of each eye. Consequently, this system was also dropped from consideration.

3.2.1.3 Asymmetrical Relay System

Figure 3-6 shows a proposed system with light pipes around the side of the helmet possessing extreme asymmetry. The asymmetrical relay system optical analysis showed the effects of chromatic dispersion and loss of



TA/4753

Figure 3-6. Asymmetrical relayed system. Light pipe around sides of helmet.

efficiency, due to the amount of asymmetry. Because of these factors, it was not recommended over the symmetrical system. The nature of diffraction optical elements is such that, when used in an asymmetrical geometry, they exhibit a grating characteristic which diffracts different wavelengths at different angles. This can cause a spreading out of display light which destroys sharpness and fine detail. Since the amount of dispersion increases with increasing asymmetry and increasing display bandwidth, it is necessary to minimize both. Figure 3-7 indicates the geometric parameters which influence the amount of dispersion. An upper dispersion limit of 0.5 milliradians (based on the size of one TV resolution element) would be appropriate. In order to maintain this magnitude of dispersion with a two nanometer bandwidth source (P-43) and a representative bend angle of 50° , the degree of asymmetry could not exceed approximately 4° . A means of dispersion correction in an asymmetrical system using a second hologram has been proposed, however, this solution is obtained through a probable sacrifice in optical system complexity.

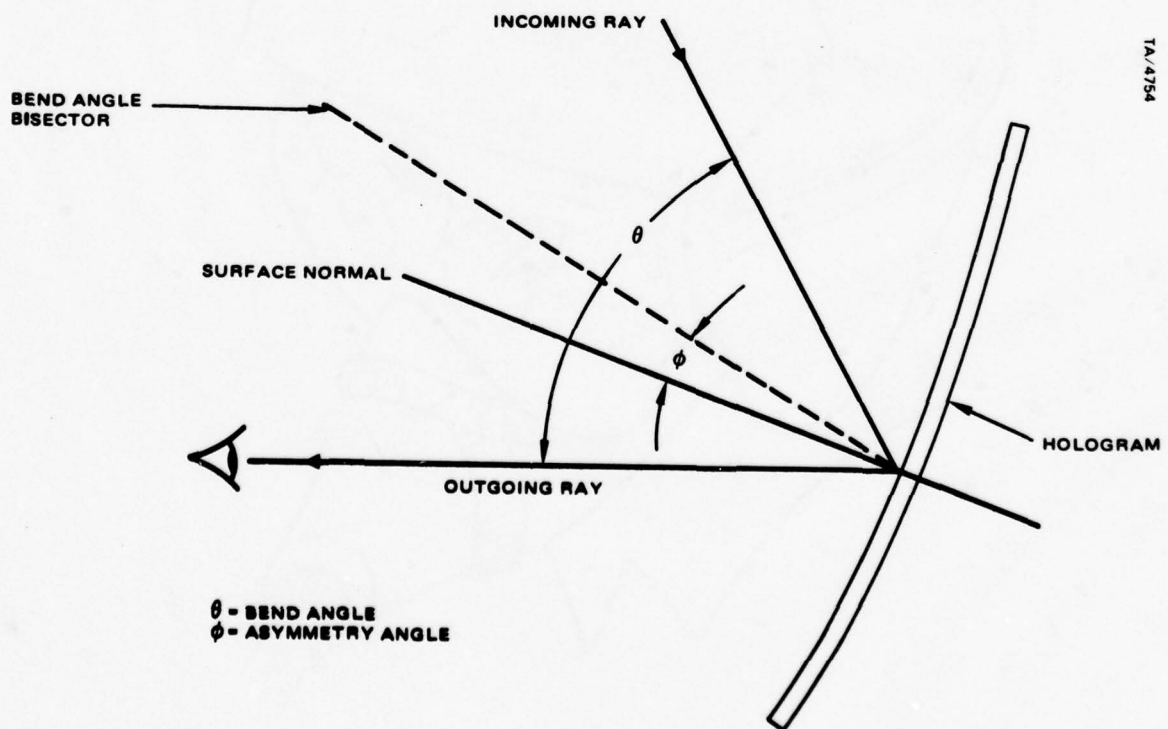

Figure 3-7. Hologram geometry definitions.

3.2.1.4 Symmetrical Relayed System

Based on optical system performance the symmetrically relayed system was chosen to be pursued. Optimistic performance regarding resolution and efficiency was predicted early in the development of this system. The symmetrical system development required the top edge of the visor to be tipped forward, so that the eye relief is 2.80", and so that the bend angle at the hologram would be minimized, thus maximizing the efficiency and reducing the geometrical aberrations. Physical relationships between the visor shape, visor tilt, eye relief, exit pupil size look up angle clearance, and the physical size of the relay lens system design were now becoming obviously interrelated. The interrelationship being very complex required the use of a computer program to be established that would readily show side, top and front views of the head, look up angle, hologram, all lens elements, and the folding mirrors. The printouts were updated to reflect physical and optical design changes as new ideas were tried to reduce the bend angle and improve optical performance. The four element lens relay system first designed to meet the requirements for the curved image plane of the hologram was maintained and modified throughout the development.

3.2.2 Physical Tradeoffs

Several physical configurations were tried by the use of the computer. The configurations basically involved not only lens sizes and lens spacings but the incorporation of prisms and/or mirrors. The problem was to locate and package the relay optics so as to produce the best optical performance with minimal obscuration to the look-up angle. The plane of symmetry for the hologram was tilted toward the center of the forehead so as to minimize the bend angle at the hologram. The main problem was that the two optics systems for both eyes could not physically interfere with each other. The following schemes were evaluated using computer drafting techniques: 1) optics folded toward the side of the head, so that light pipe would bend around near the side of the head, 2) optics folded to go vertically up over the top of the head, and 3) optic paths crossing one another at the center of forehead using a common mirror or prism.

TA/4755

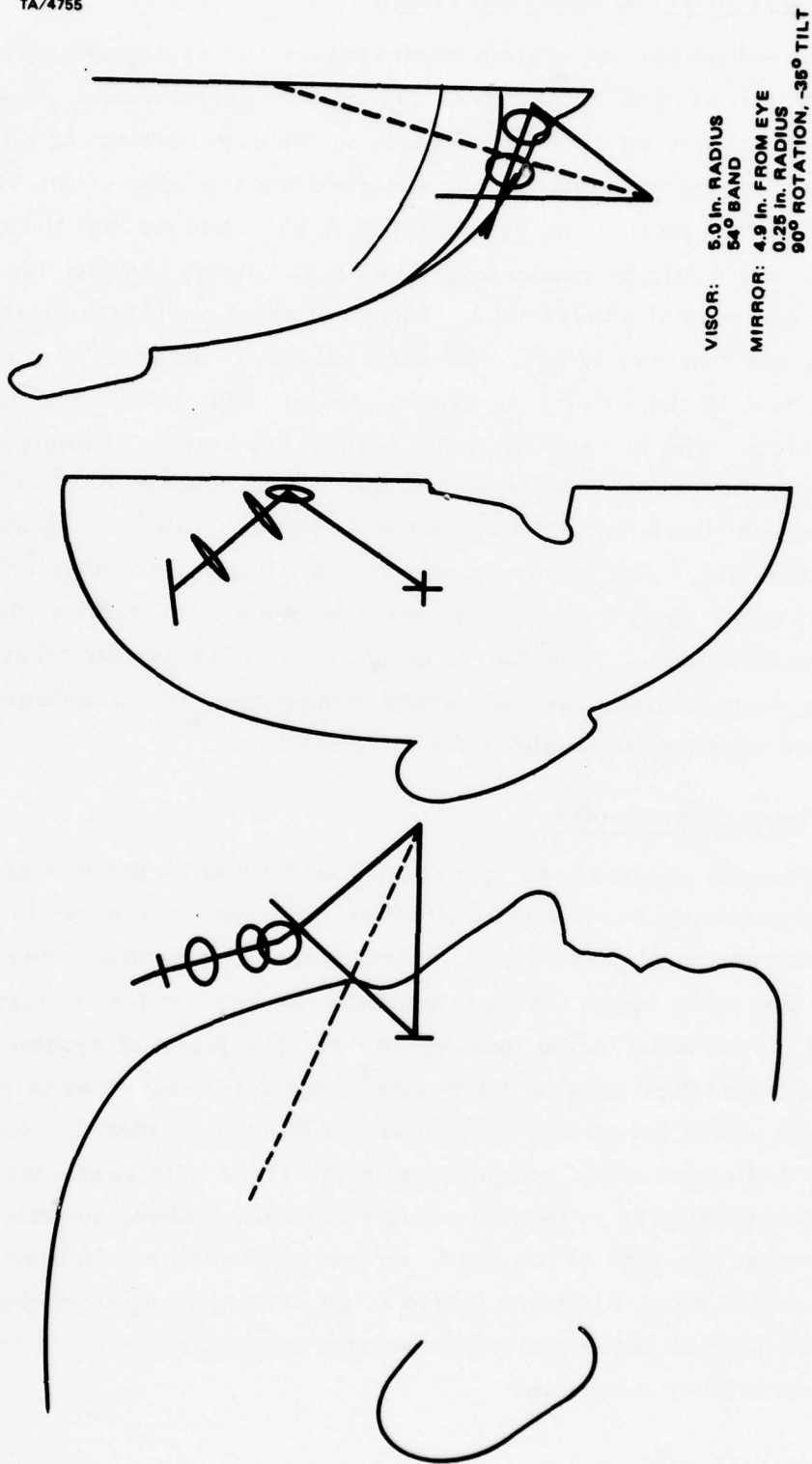

Figure 3-8. Relay optics folded to side of head.

3. 2. 2. 1 Relay Optics Folded Toward Side of Head

Computer programming was performed to evaluate the possibility of laying the optics in a horizontal position in order to bring the light pipes around the sides of the head. A typical print out of the computer program is shown in Figure 3-8. This shows the first folding mirror in a vertical position. The bend angle at the hologram for this study was 54° , and the visor radius was 5.0 inches. A visor radius of 4.75 inches was also tried, which decreased the bend angle at the hologram. To bend the optics in a more horizontal position would require a greater tilt of the mirror. The gut ray leading to the center of the mirror would have to be rotated to a more upward position, and this would cause an increase in the bend angle at the hologram, thus, reducing performance of the system. Therefore, this approach was not further pursued.

3. 2. 2. 2 Relay Optics Folded Upward

This appeared to have some merit at first, but when analyzed it became apparent that the folding mirror would have to be translated horizontally, away from the head centerline to perform the fold. This had the same undesirable drawback as did the side directed optics mentioned above; the bend angle at the hologram would increase for the optics to clear the operator's head.

3. 2. 2. 3 Crossed Path-Upward Folded Optics

The ultimate goal in the various layout trials was to reduce the bend angle at the hologram as much as possible and still produce adequate clearance at the forehead. A bend angle of 50° was obtainable by crossing the optical paths as indicated in the computer printout of Figure 3-9 and changing the visor radius of curvature to 4.5 inches. The cross path design required the first lens elements to be spaced further from the hologram for clearance between the two systems and clearance from the folding mirror. The final configuration was obtained after many iterations between the physical restrictions and the optical design required for best performance. A second folding mirror was added so as to improve the overall packaging configuration. This also resulted in a change in the optics design. The final physical organization is extremely compact. The clearance to the forehead

is 0.25 inch, which is considered marginally adequate. The obscuration to the field of view is less than 4 percent, having no practical significance, as what cannot be seen by one eye can be seen by the other. A discussion of the optical performance is contained in Section 4.0.

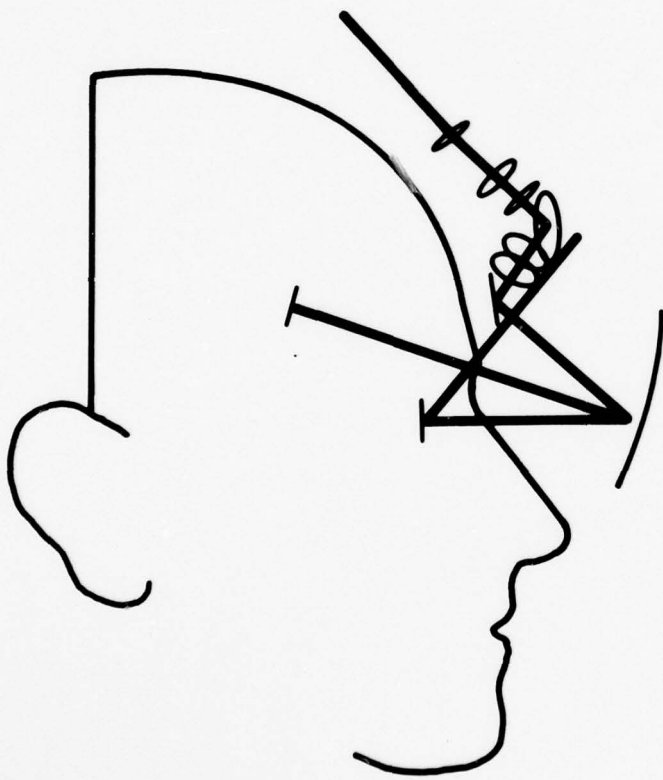

SIDE VIEW

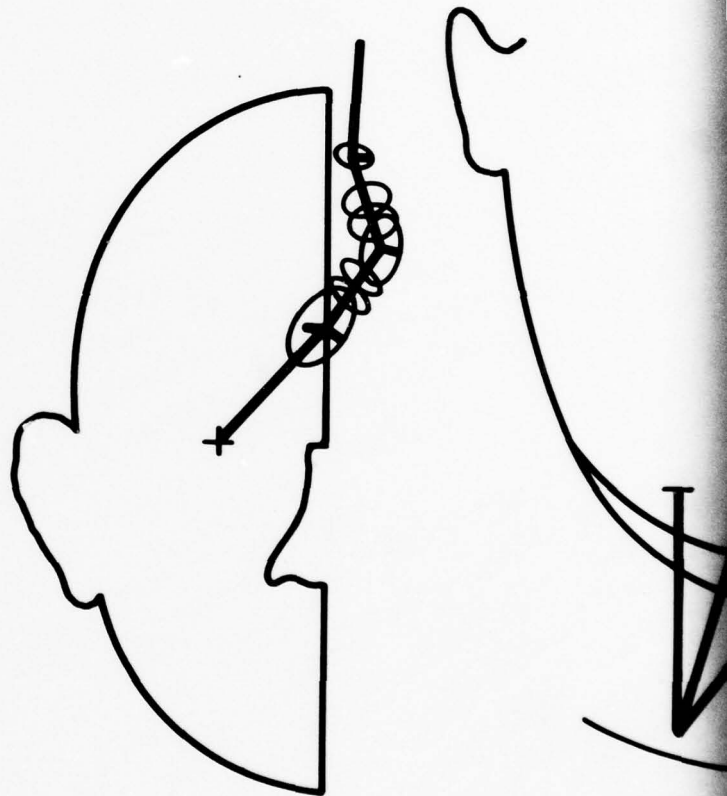

FRONT VIEW

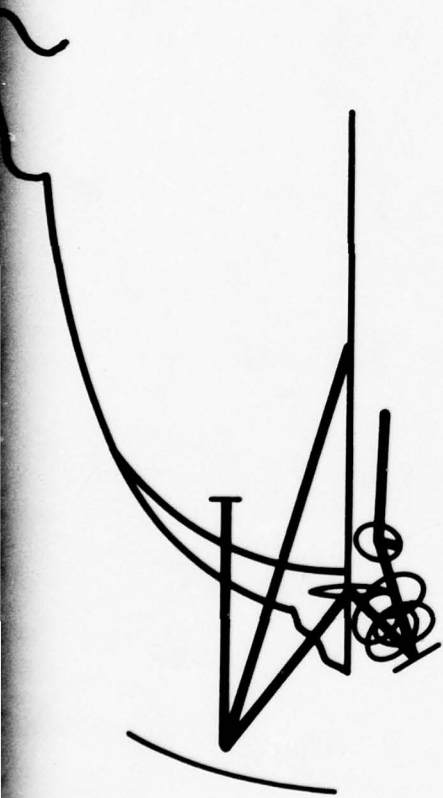

TOP VIEW

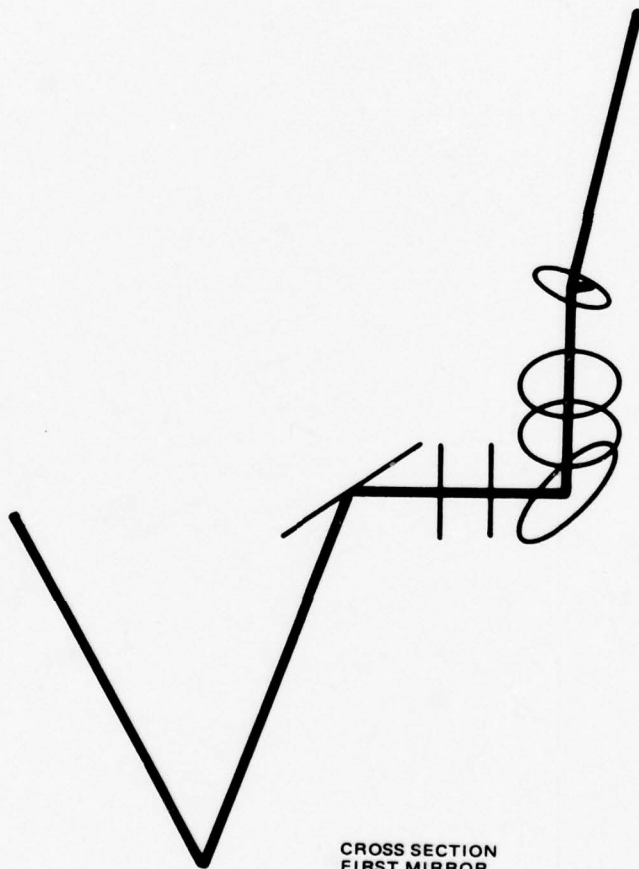

CROSS SECTION
FIRST MIRROR

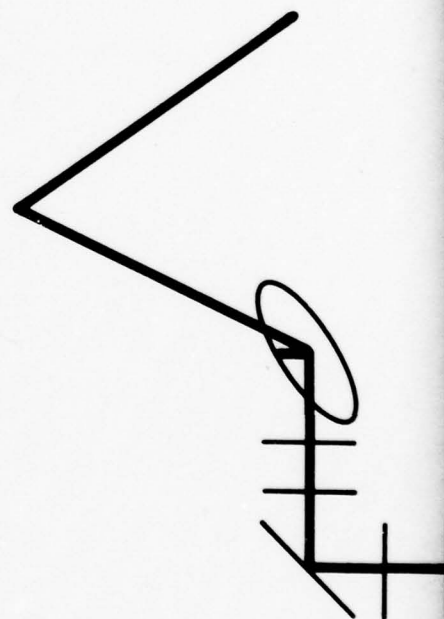

CR
SE

TA/4756

VISOR: 4.5 IN RADIUS, 50° BEND
FOB: 7.99 IN FROM EYE
LENS FACES: 5.55, 5.86, 6.81, 7.21 IN
FROM EYE

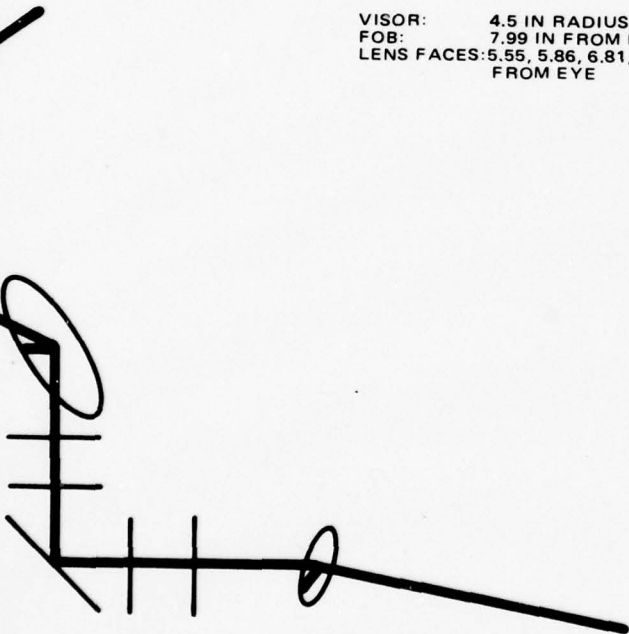

CROSS SECTION
SECOND MIRROR

Figure 3-9. Crossed-path optics design.

4.0 BHHD OPTICAL DESIGN

4.1 OPTICAL DESIGN SUMMARY

The Binocular Holographic Helmet Display (BHHD) optical system is designed to project the image of a dual display CRT onto the eyes of the helmet wearer. Light is transmitted to the eyes through fiber bundles to a relay lens to a Holographic Optical Element (HOE), which serves as an eyepiece, diffracting the light to the eye. Figure 4-1 shows a preliminary

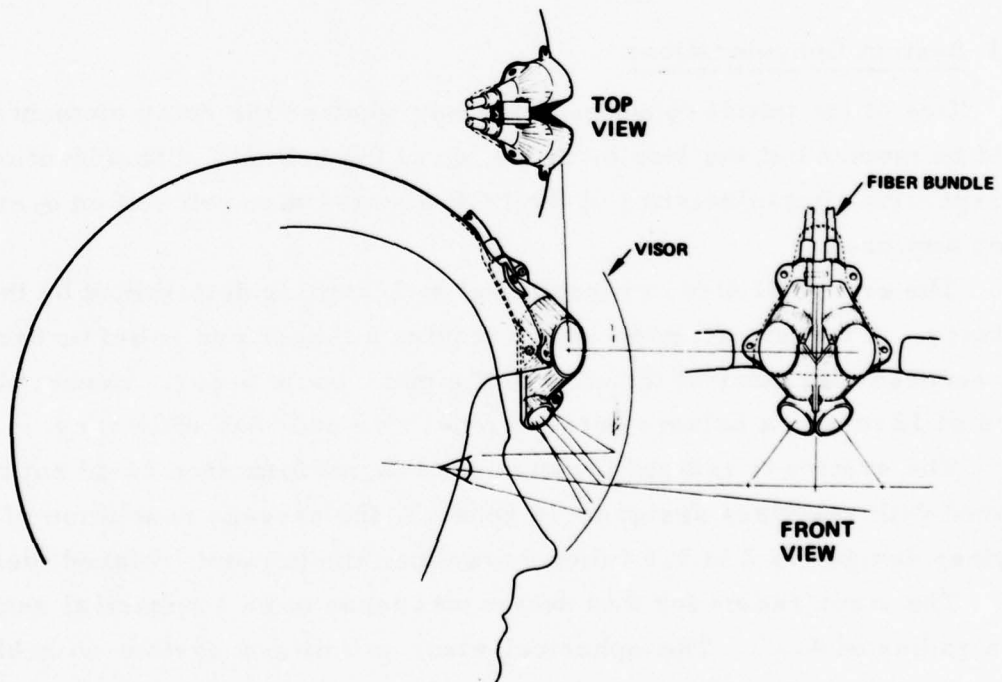

Figure 4-1. BHHD relay assembly (preliminary configuration).

configuration where the relay elements are mounted to the helmet, as opposed to another possible configuration where the relay elements are integrated with the visor.

Performance requirements include good image quality (~1 mrad aberration) over a 15° field of view (FOV) for each eye, binocular alignment, and efficiency of the HOE. These performance requirements have been met as shown in the following sections.

This section discusses the optical design work done for BHHD. A brief summary of the optical design is given in this introduction while detail system design considerations are presented in Paragraph 4.2. Paragraph 4.3 reports on the performance of the BHHD system.

4.2 OPTICAL DESIGN OF THE BHHD

In discussing the design in detail, this section is divided into 3 subsections: a) system considerations, b) the holographic lens design, and c) relay optics.

4.2.1 System Considerations

One of the initial considerations was whether the relay elements should be mounted at the side or at the top of the helmet. Consideration of the dispersion characteristics of the HOE dictated the choice of an over-the-top approach.

The exit pupil size, presently set at 12 mm, is determined by the HOE efficiency. A larger exit pupil would require a larger eye relief or drastically reduced efficiency at the edge of the pupil would occur. Hence, the choice of 12 mm is a balance between pupil size and HOE efficiency.

The system is relayed because suitable performance could not be achieved with relayless designs. In general, the average resolution of the relayless designs is 2 to 3.5 times worse than the present (relayed) design.

The visor radius for this design was taken to be a spherical section with a radius of 4.5". The spherical visor permits a system with bilateral symmetry. In order to reduce the effects of dispersion, the visor is tilted about the cheekbone, so that the bend angle of the hologram is

bisected by the normal to the visor. The resulting system has an eye relief of about 2.8" and a bend angle of 50 degrees.

With this configuration, the combining mirror can be placed above the wearer's field of vision when he looks up. The mirrors are located at the center of the forehead so that rays from an intermediate image reflect symmetrically from the HOE. That is, the angle between an incident ray and the visor normal is equal to the angle between the normal and the exiting ray. This makes the HOE free of dispersion and tends to be beneficial in terms of monochromatic aberrations.

The axis of bilateral symmetry is tilted from the vertical head line toward the nose by 41.09 degrees. All folds are done with mirrors to facilitate packaging and reduce weight.

Figure 4-2 shows an optical schematic of the BHHD from the eye to the fiber bundle end on the helmet. Figures 4-3 through 4-5 show the BHHD elements viewed from various angles. Table 4-1 lists the optical characteristics of the system.

4.2.2 Holographic Lens Design

The HOE construction optics is formed with the reference and object beams incident on the HOE from opposite sides, forming a reflective hologram. One construction point source must be located fairly close to the exit pupil in order to obtain the high efficiency across the 15° FOV. A cylindrical lens is used in the object beam to correct on-axis astigmatism which arises from the lack of rotational symmetry in the design. It also affects the tilt of the image plane formed by rays traced in the plane of symmetry.

4.2.3 Relay Optics

Once a decision to go with the relayed BHHD design was made, a Petzval-type relay was chosen for the initial form. To reduce axial coma, the lens element nearest the fiber bundle was tilted about 9.24 degrees. An intermediate image is formed close to, but not on, a folding mirror. A window has been placed between the visor and the relay elements to serve

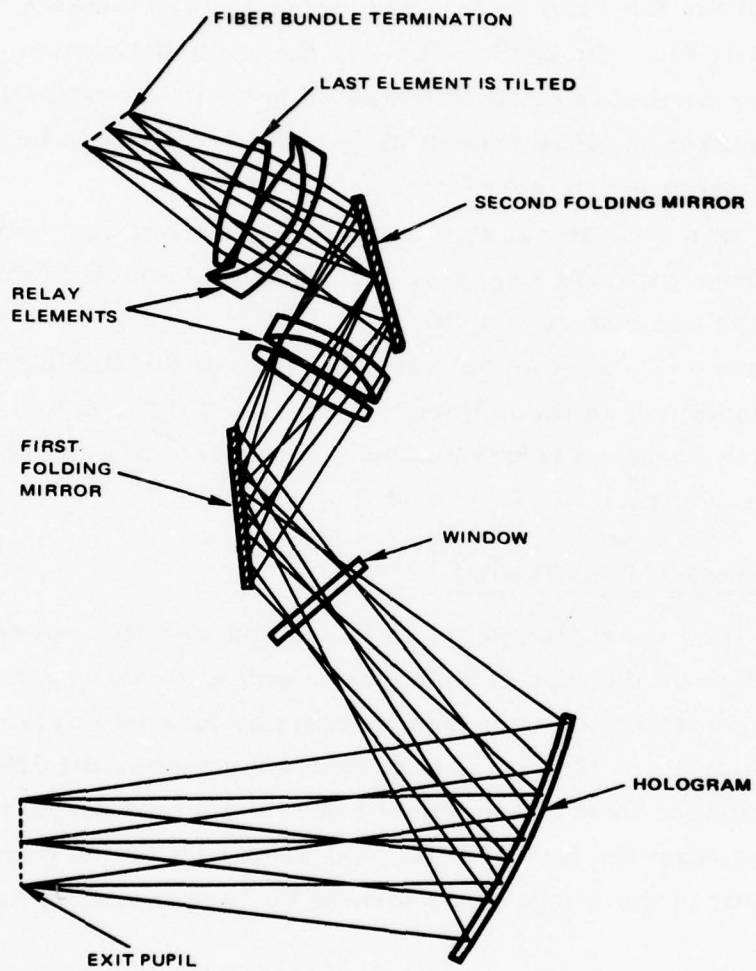

TA/4787

Figure 4-2. Optical schematic of BHHD elements.

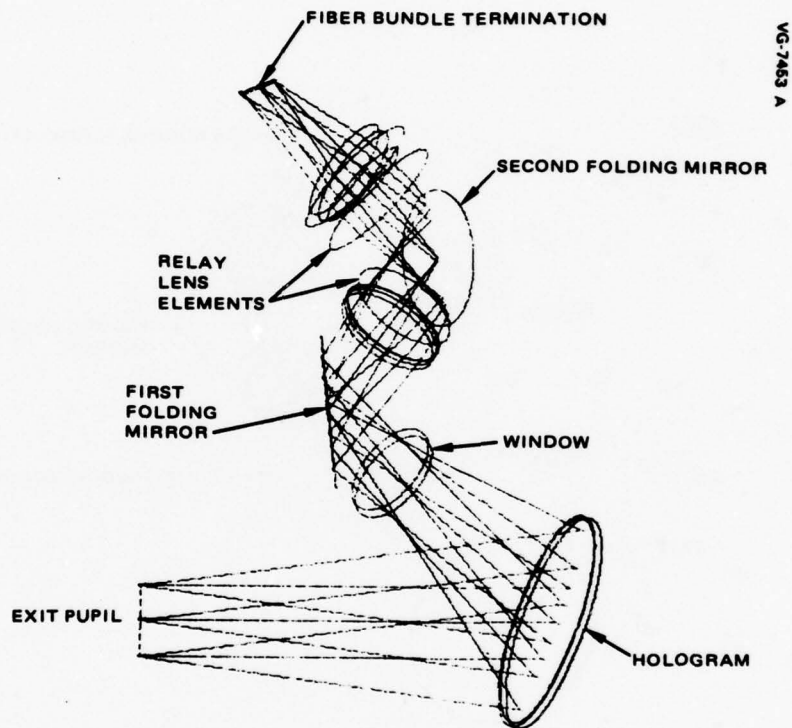

Figure 4-3. Side view of BHHH elements.

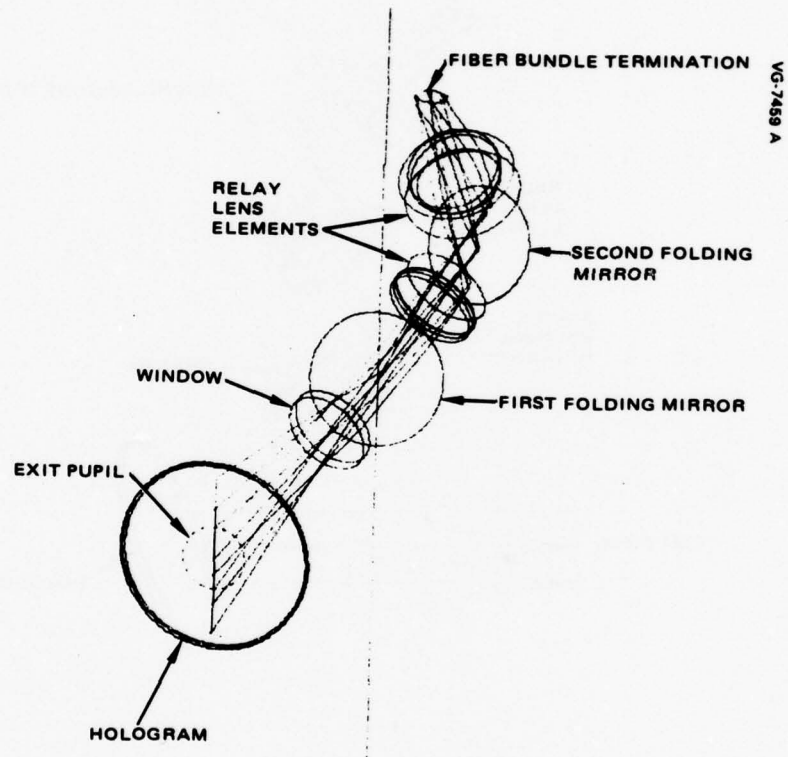

Figure 4-4. Front view of BHHH elements.

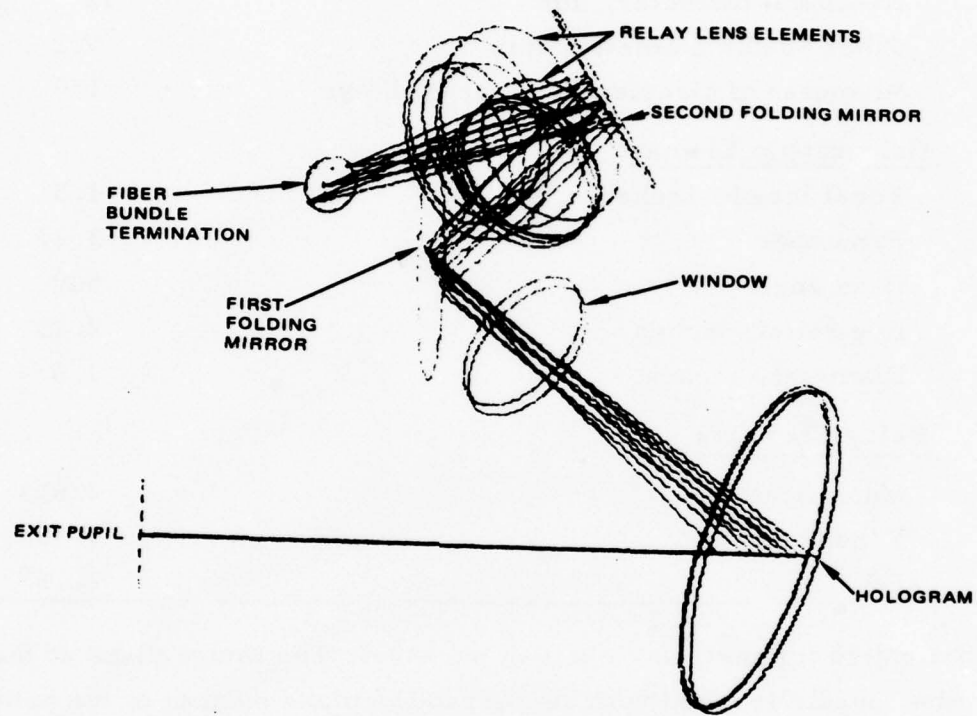

Figure 4-5. Top view of BHHH elements.

TABLE 4-1. BHHD OPTICAL CHARACTERISTICS

<u>System</u>	
Focal length, mm	27.3
F/number	2.3
Exit pupil diameter, mm	12
Fiber bundle diameter, mm	7.2
Diameter of circular FOV, at each eye	15°
<u>Holographic Element</u>	
Focal length, inches	1.5
F/number	3.41
Bend angle	50°
Eye relief, inches	2.75
Diameter, inches	1.6
<u>Relay Elements</u>	
Magnification	0.613
F/number	1.30
FOV	12.5°

as a dust shield for the relay element package. The image plane at the end of the fiber bundle is tilted with respect to the plane normal to the optical axis. Figure 4-6 indicates the image orientation of the fiber bundle.

4.3 BHHD PERFORMANCE

The center field aberrations are presented in Figure 4-7 where the angular deviation of the zero field rays through the 12 mm diameter exit pupil are shown. The maximum angular deviation is about 2.0 mrad. The pupil of the eye has at most a diameter of 8 mm. The real accuracy perceived by the eye is the average angular deviation over any 8 mm diameter that overlaps with the 12 mm diameter exit pupil. In this sense, the zero field accuracy is less than 1.0 mrad.

The geometrical aberration curves are shown in Figures 4-8 and 4-9. The notation on the curves is as follows: DYDY is the vertical deviation

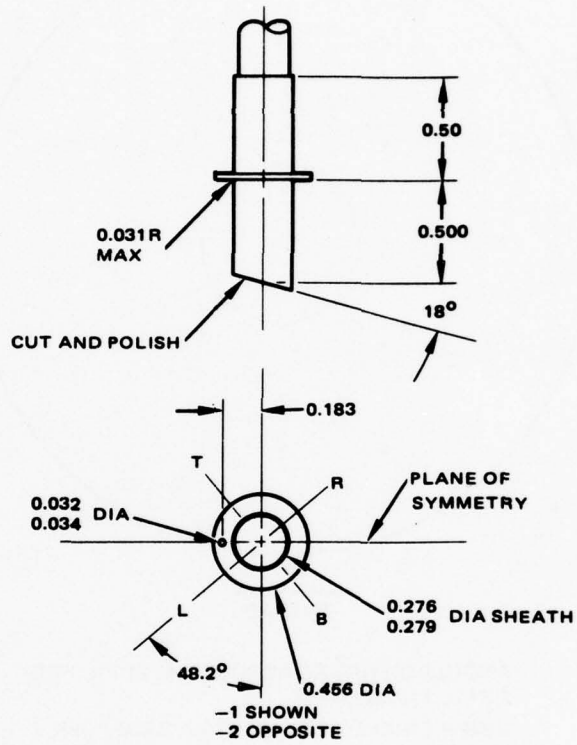
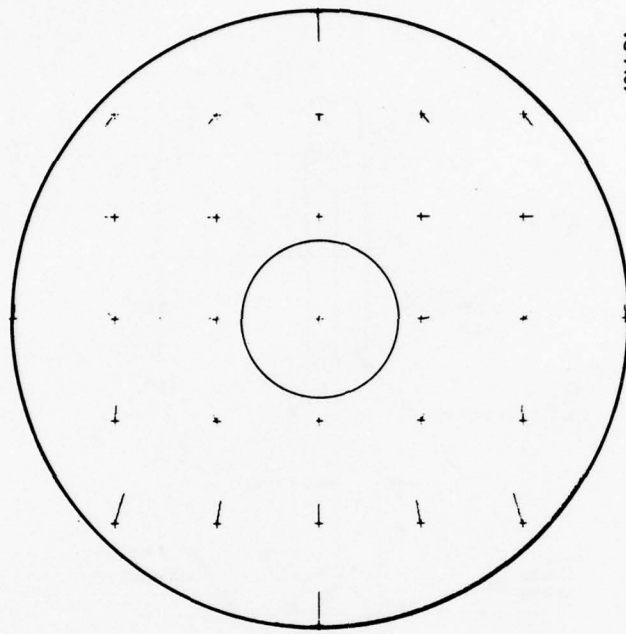

Figure 4-6. Orientation of image at fiber bundle.



ANGULAR ERRORS ACROSS THE PUPIL FOR
AXIAL FIELD POINT
INNER CIRCLE REPRESENTS A 3 MM PUPIL

Figure 4-7. BHHD angular errors
across pupil.

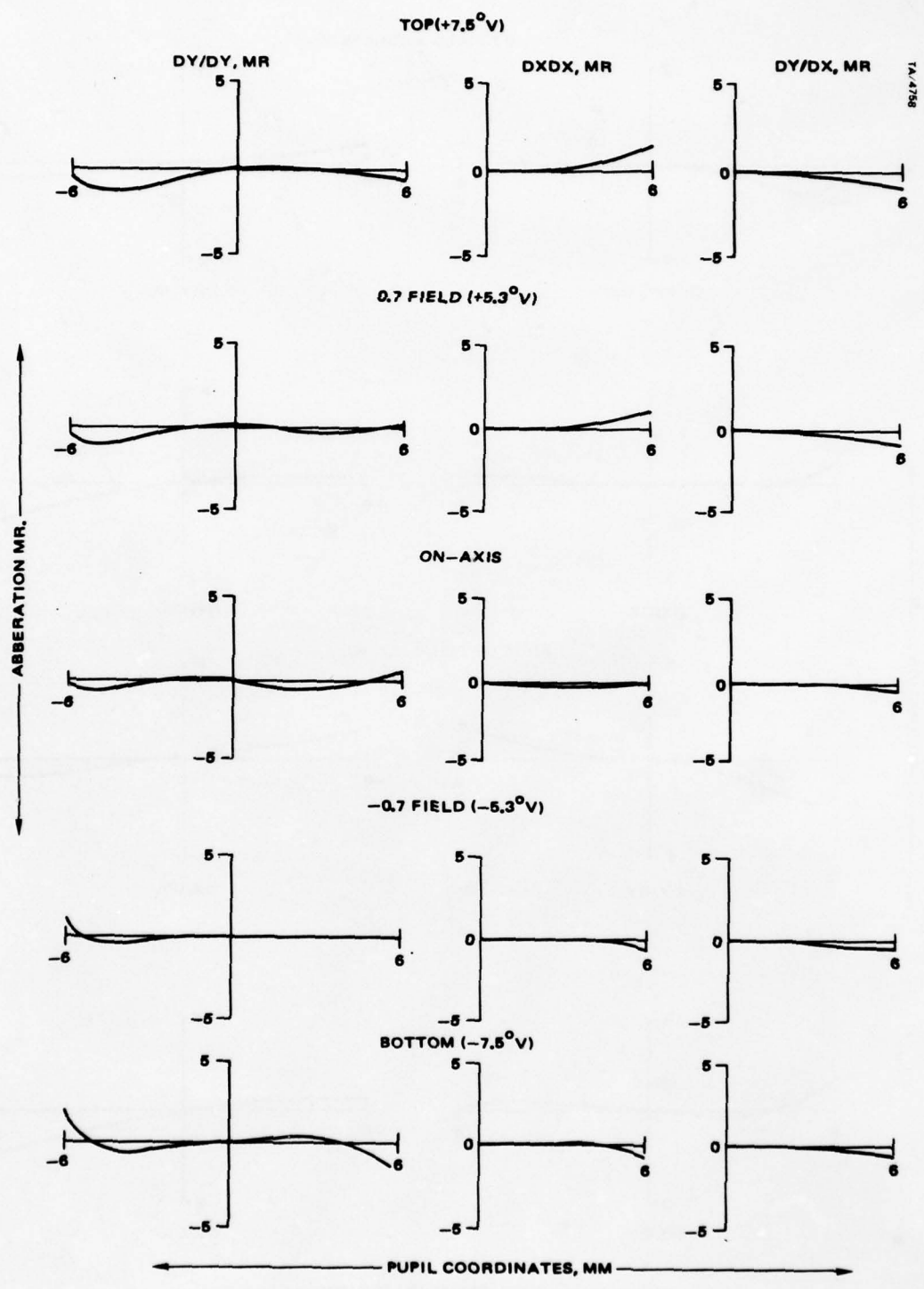

Figure 4-8. Ray aberration curves for vertical FOV.

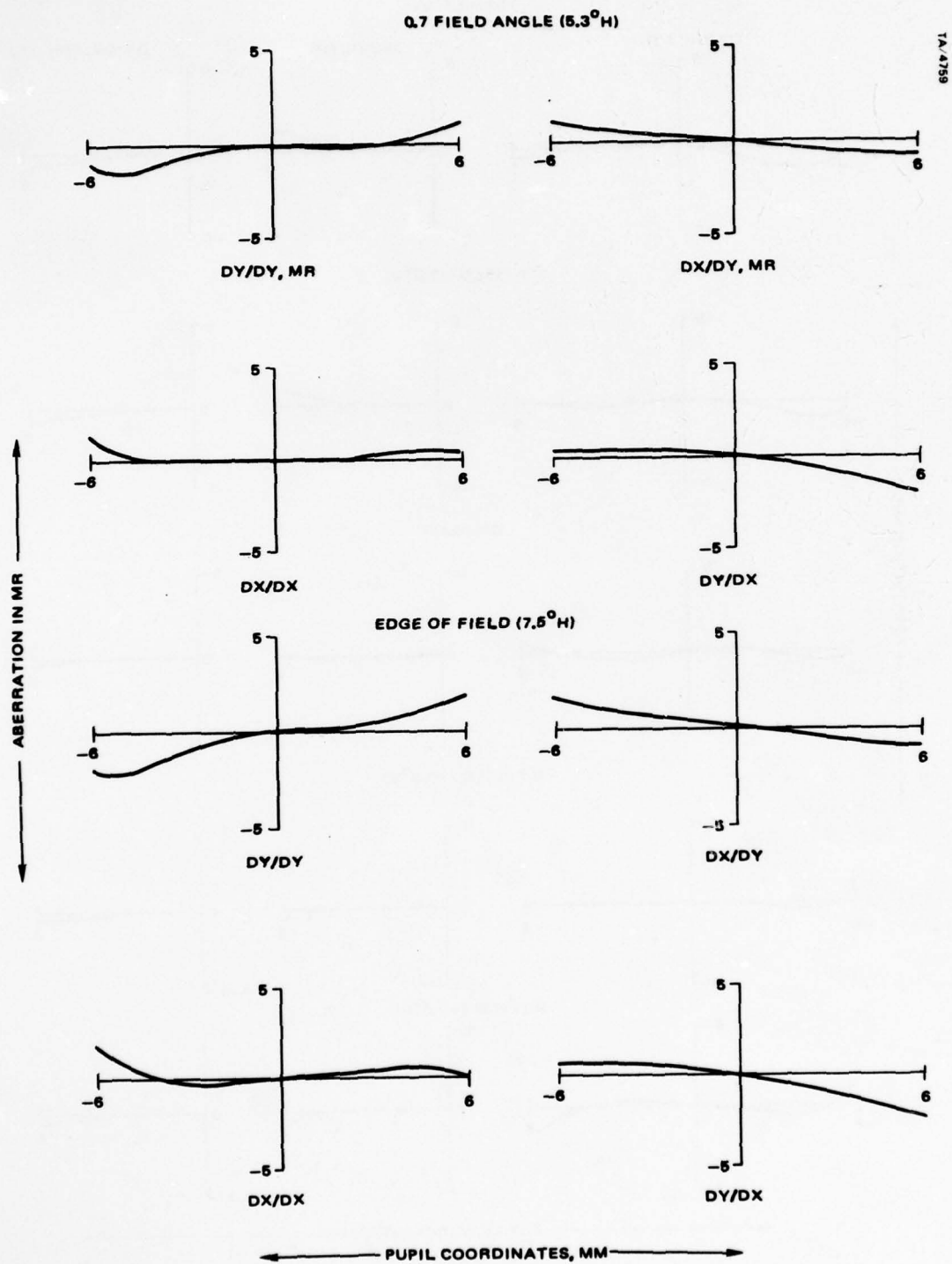

Figure 4-9. Ray aberration curves for horizontal FOV.

of the rays in a bundle along a vertical line in the exit pupil from the central ray. DXDY is the horizontal deviation for the same ray bundle; DXDX is the horizontal deviation of the rays in a bundle along a horizontal line in the exit pupil from the central ray. DYDX is the vertical deviation for that ray bundle. Position of the rays across the pupil is indicated by the position along the abscissa of the figures. The scale indicated on the ordinate axis covers the range $-0.005''$ to $+0.005''$, which corresponds to ± 5 milliradians respectively.

The maximum deviation is 2 mrad. In the horizontal field of view, the astigmatism becomes the dominant aberration. This fact is clearly reflected in the MTF curves, as shown in Figure 4-10. The MTFs are calculated for a 5 mm diameter eye pupil at the center of the exit pupil. Performance on the vertical field is quite good, whereas the horizontal field of view degrades rapidly.

Figure 4-11 shows the distortion of a grid of square segments at the exit pupil. This pattern should be displayed at the end of the fiber bundle in order to produce an undistorted image at the eye. The distortion can be broken down into the following components:

Doughnut	4%
Asymmetric	16%
Rectangular	15%
Keystone	5%

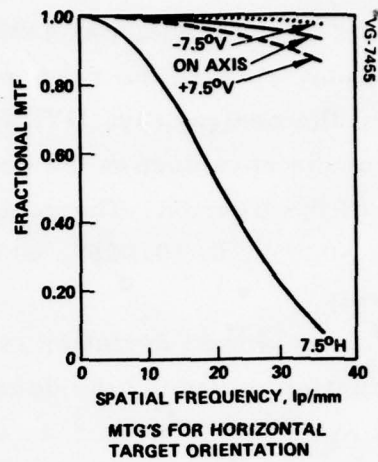
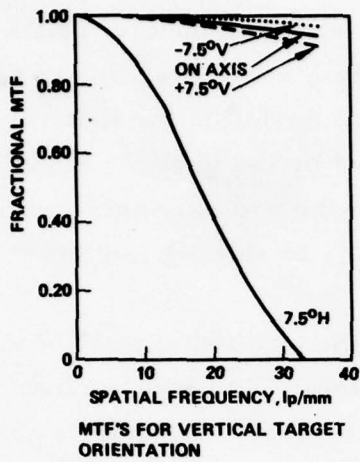

5MM EXIT PUPIL DIAMETER IS USED FOR SINGLE EYE

Figure 4-10. BHHD MTF curves.

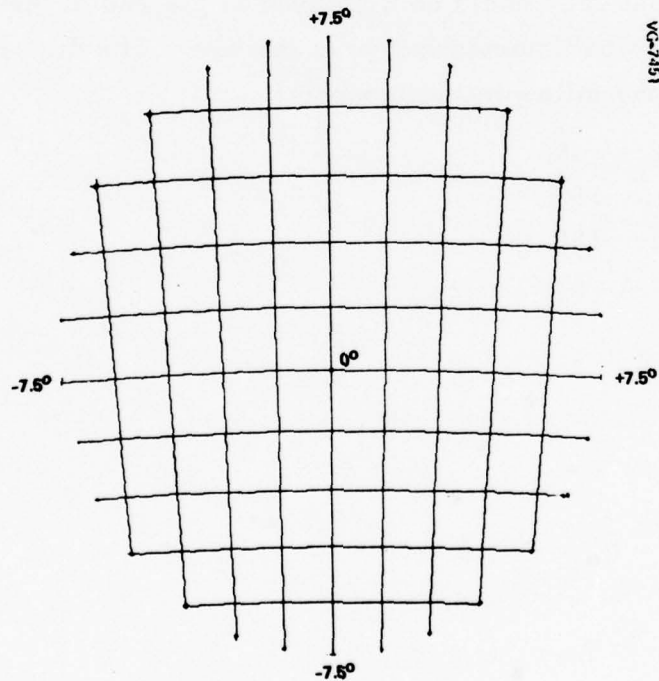

NOTE:

- SQUARES ARE $1.5^\circ \times 1.5^\circ$
- IF THIS PATTERN WERE DISPLAYED ON THE FIBER OPTICS BUNDLE, THE USER WOULD SEE A PERFECT GRID OF SQUARES

Figure 4-11. Map of distortion.

5.0 PHYSICAL DESIGN

The proposed BHHD design is composed of a modified helmet, a helmet bracket assembly, the visor/hologram assembly, and the relay optics assemblies. The two fiber light pipes come over the top of the helmet, are attached to it and interface to the relay optics assembly. The visor with holograms is precision indexed to the relay optics assembly in the down position and rotates out of view in the up position. The relay optics are mounted fixed to the helmet bracket assembly which in turn is rigidly mounted to the helmet. A modified visor cover provides protection to the optics and visor. The overall configuration is pictured in Figure 2-1, the layout is shown in Figure 5-1.

5.1 VISOR MOUNTING DESIGN

The proposed mounting of the visor provides accurate registration of the hologram to the relay optics by precision mounting of the visor and the relay optics assembly on brackets that pivot relative to each other and are indexed accurately to each other at the operating position. This mounting scheme is shown in Figure 5-2.

The visor is a spherical plastic bubble shape with a radius of four and one half inches. It is bonded to a stiffener frame that is fabricated to extend across the top of the visor to the pivots at each side of the head. The bonding will be accomplished while the visor is positioned and held firmly in a fixture at the required position so that the directionality and coordinates of the holograms are within design tolerance. The stiffener frame maintains the shape of the visor at all times.

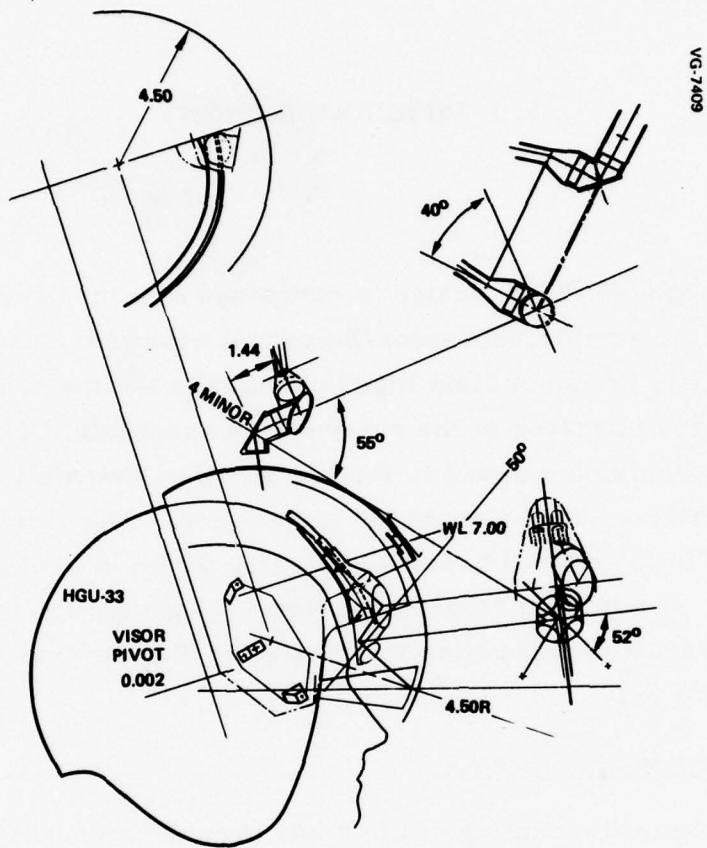

Figure 5-1. BHHD layout.

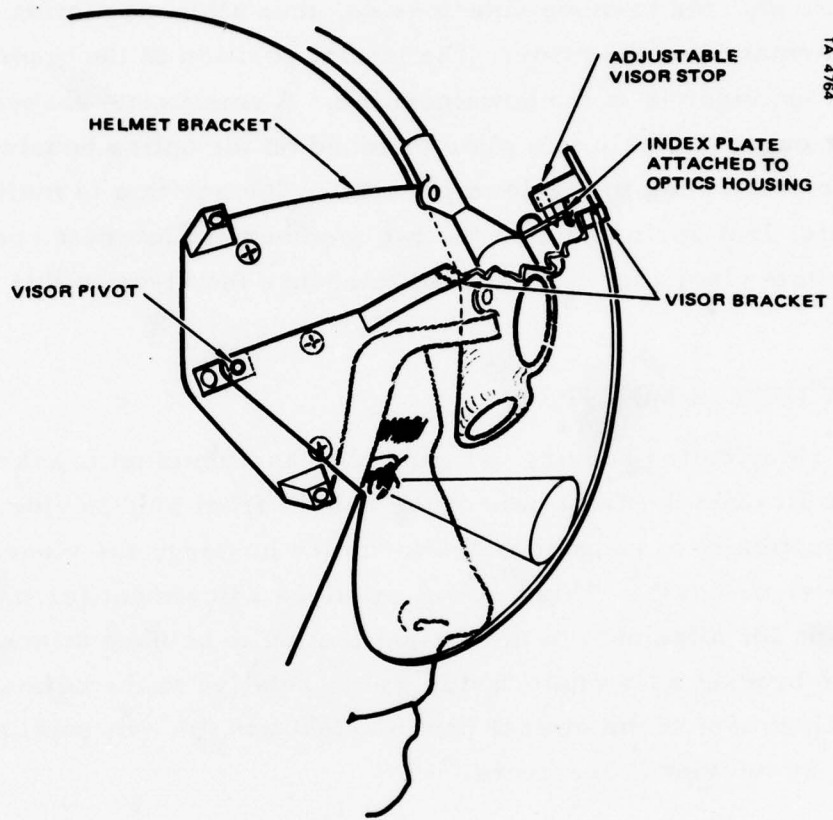

Figure 5-2. Optics/visor mounting scheme.

5.1.2 The visor assembly pivots around the helmet bracket in such a manner that it is entirely free to move side-to-side, thus allowing motion without causing deformation of the visor. The lateral position of the visor is determined when the visor is in the down position. A small cone shaped pointer on the visor engages a hole in a plate mounted on the optics housing to provide the accurate positioning in the down position. The position is maintained by an over center leaf spring holding the two members in intimate contact. The standard helmet visor lock is also used to secure the visor in this latched position.

5.2 RELAY OPTICS MOUNTING

The relay optics housing is mounted to an aluminum bracket that is contoured to fit over the front part of the helmet from side to side. The bracket's function is to support the relay optics housing, the visor assembly, and the visor cover. This bracket provides adjustment for the relay optics housing for alignment to the optical tooling to be used at assembly. In addition, the bracket as a whole is adjustable relative to the helmet so as to allow for adjustment of the optical line-of-sight and the exit pupil position as required by individual operators.

5.3 RELAY OPTICS HOUSING

There are two optical relay lens systems, one for each eye. The computer aided design that provided the best look-up angle and most forehead clearance and minimum bend angle at the hologram, produced a relay design where the optic paths of both systems folded at the center of the forehead using the same mirror. The distance of the first lens elements from the hologram was designed so that the fold was practical considering mechanical mounting of the mirror and the nearest lens element. A second fold was necessary to align the optic paths for packaging to contour to the helmet as much as possible including the interface with the fiber light pipe. Front and side views of the housing is shown in Figure 2-1.

The overall appearance is that of tubes joined at compound angles with truncated joints at the positions where the mirrors are mounted. The

main reference surface is the first mirror from the hologram. The tube centerlines are referenced by angle to that surface and the assembly centerline. The directionality of the second mirror is referenced by the angle of the mirror normal to the reflected gut ray coming from the first mirror and by rotation of that normal from the previous bend plane. These two angles for each bend related to the last bend make it easy for accurate machine measurement for tool fabrication.

The optics housing will be fabricated in two halves and bolted together. The lenses are to be bonded in place with spacers and machined shoulders. The top openings are machined to accept the fiber light pipe sleeve and shoulder. The light pipe is positioned by its diameter and an index pin, and is held in place by screws to the housing. The assembly is made dust proof by installation of the glass window at the front exit going to the hologram.

The above description of the housing is based on the optics design using mirrors. The first mirror of the system may be replaced by a prism in order to make the two optic systems independent. This will allow for translation of one system relative to the other for adjustment for specific interpupillary spacings. The prism in this case will replace the sealing window and mirror and alter the method of mounting to the helmet bracket.

5.4 FIBER LIGHT PIPE TERMINATION

The fiber light pipe must be cut and polished at an angle to its centerline to satisfy the optic design. This angular cut provides the optical matching necessary to compensate for the angular intermediate image required by the hologram. The cut is with respect to the plane of symmetry of the relay optics and hologram. In addition, the top-bottom, left-right orientation of the image must be located at a specific angle related to the cut. Preliminary interface requirements are shown in Figure 4-6 for the two light pipes.

5.5 WEIGHT AND C.G. ANALYSIS

The physical changes to the helmet require certain parts to be removed from the helmet and new assemblies to be added as replacements.

This changes the weight of the final assembly and its center of gravity. The following table summarizes the initial and final Weight and C. G. Shift.

Initial HGU-33 weight	28.96 oz
Weight of parts removed	6.76 oz
Weight of Helmet with parts removed	22.20 oz
Weight of parts added	16.7 oz
Final weight of BHHD	38.9 oz
C. G. Shift forward	0.99 in.

The data estimates and C. G. calculations are as follows:

<u>Parts Removed</u>	<u>Wt. oz</u>	<u>Dist. from C. G., in.</u>
Visor	2.69	+3.7
Visor tracks	1.125	+1.5
Cover	<u>2.94</u>	+2.7
	6.76	
<u>Parts Added</u>	<u>Wt. oz</u>	<u>Dist. from original C. G. in.</u>
Optical assy	2.9	4.1
Visor assy	5.5	4.2
Helmet bracket	3.5	2.2
Cover	<u>4.8</u>	1.4
	16.7	

Horizontal Shift of C. G. resulting from parts removed.

$$\begin{aligned}
 EM &= 0 \\
 &= 22.2 (X') + 1.125 (1.5) + 2.69 (3.7) + 2.94 (2.7) \\
 0 &= 22.2 X' + 19.57 \\
 \therefore X' &= -0.88 \text{ in. (rearward)}
 \end{aligned}$$

Horizontal Shift of C. G. resulting from new parts added.

$$\begin{aligned}
 M &= 0 \\
 &= 22.2 (-0.88 - X) + 2.9 (4.1 - X) + 5.5 (4.2 - X) + 3.5 (2.2 - X) + 4.8 (1.4 - X) \\
 0 &= 29.87 - 38.9 X \\
 X &= 0.77 \text{ in.}
 \end{aligned}$$

5.6 ALIGNMENT METHODS

Three methods to accomplish accurate registration of the holographic combiner to the relay lens assembly were investigated. The basic accuracy requirements to produce the best performance are as follows:

Axial position of hologram from relay lens, ± 0.010 in.

Radial position of hologram from centerline, ± 0.02 in.

Tilt, angular position from design, ± 2 mr

These tolerances are extreme considering the flexibility of the helmet materials and the expected handling of the helmet. They are based on an analysis where tolerances occur throughout the optical train and include the mounting of the fiber bundle, the four lens elements and the mounting of the optical assembly to the helmet bracket. The analysis used RMS summation as the probable effect on the total system. The following is a discussion of two of the three methods of registration. The selected method was described in Section 5.1.

5.6.1 Combiners and Relay Optics Mounted to Visor

This method employs fixed holograms mounted to or produced within the visor and a mechanism to mount, pivot and index the relay optics assembly relative to the visor. Figure 5-3 shows the relay optics assembly in the operating position and in the folded up position. It is spring loaded into the operating position and positioned accurately by adjustment screws. It is held by four pivot arms, two on each side; the arms pivot about support points attached to the visor. The visor requires stiffening to provide the necessary rigidity to support the relay optics, the pivoting mechanism, and part of the weight of the fiber light pipes. The following factors are necessary to this design approach: 1) the visor pivot radius at the side of the helmet is increased over the selected design in order for the body of the relay optics to clear the helmet, 2) the visor cover is enlarged to accommodate the larger radius of swing of the visor, 3) the fiber bundle must be positioned on the helmet as shown to allow for it to flex as the visor is moved, and 4) the optics housing slides over the helmet as the visor is

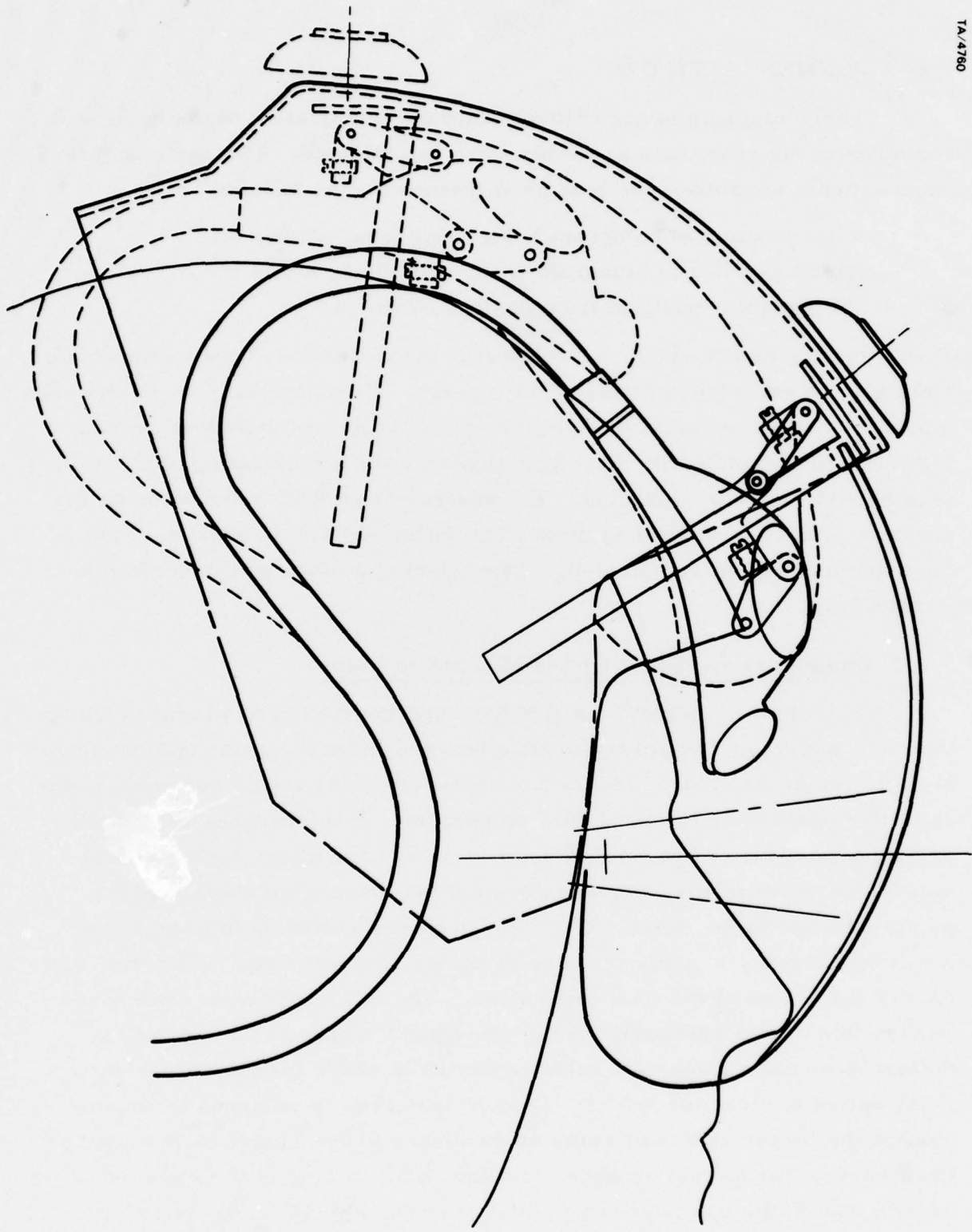

Figure 5-3. Combiners and optics mounted to visor.

translated. Other packaging schemes of the relay optics were considered to reduce the larger radius of swing, but they increased the bend angle at the hologram, thus reducing optical performance.

5.6.2 Bracket-Held Holograms Independent of Visor

This method uses a frame internal to the visor that pivots on the same pivot points as the visor. The hologram is linked to the visor frame, so that it moves as the visor retracts but is not subject to any forces other than a spring which is used to hold it to the index point when in the down position. The concept is shown in Figure 5-4. The index point is an extended tab with a hole, that is mounted to the optics housing, which is engaged by a pointed screw that is held by the hologram frame. This method of pivoting and indexing is the same as the selected method shown in Figure 2-1, which allows the frame to translate as it moves, but when the index pin engages the lateral position of the visor is determined. Vertical position of the hologram frame is adjusted by the screw pin. The frame work holding the hologram to the pivoting structure is designed to minimize obscuration in the visual field. The frame work forms a series of triangles to maximize rigidity in three dimensions, while being an extremely light weight design. The framework also provides a small amount of horizontal adjustment of the holograms to allow for interpupillary variation. Actual bonding of the hologram to the frame requires special tooling to accurately hold the holograms at the correct angle relative to the center line ray of the relay system.

6.0 FABRICATION TECHNIQUES

6.1 DIFFRACTION LENS

Fabrication of the diffraction lens elements used the diffraction optics technology which was previously developed for helmet mounted, goggle mounted, and heads up display systems. The specialized laser equipment is mounted to a shock proof granite flat housed in a closely controlled air conditioned room. The reference and objective laser beams must not move relative to each other during exposure. Development, cementing and processing require closely controlled equipment and test equipment.

The diffraction lens is a reflecting optical element formed by layers of varying index of refraction recorded in a thin film. Both the spacing and orientation of these layers are chosen to give the desired optical function. The element is holographically fabricated by recording a set of three-dimensional interference fringes within a light sensitive film. The recorded fringes represent the desired layers of varying index of refraction in the completed thin film element. The fringes are generated by an exposure apparatus which splits a single laser beam and shapes two laser wavefronts so that, when they interfere on recombination, they give the appropriate spacing and orientation of dark and light fringes in space. To record the pattern, a substrate coated with the photosensitive film is placed at the proper location in the fringe pattern until properly exposed. The photo sensitive film used in this program was dichromated gelatin. It is the best recording medium currently known for this type of reflective diffraction element because of its high diffraction efficiency, low scatter and noise, relatively good sensitivity, and good long-term stability.

6.1.1 Construction Optics Setup

A typical construction optical system setup is shown in Figure 6-1. The largest components are a 10-inch spherical mirror and a flat plate beamsplitter. The object beam enters the system from a point source located at O. The beam is expanded, bent and shaped by lenses and a prism, then reflected from a beamsplitter to the spherical mirror and reflected back through the beamsplitter as a converging beam which meets the diverging reference beam at the hologram substrate. The reference beam has no additional optics after the point source at R. The interference of the two wavefronts produces the required interference fringes in space to be recorded by the holographic element.

Also shown in the diagram are the various beam steering mirrors, lenses and beamsplitter required to produce the two point sources at O and R from the single laser beam. Also not shown are the mirrors, lenses, and detectors used in the interferometric feedback system to provide fringe stability.

6.1.2 Alignment of Setup

Proper fringe orientation demands a critical alignment of the construction optics setup compatible with the visor viewing system. Angular alignment of the beams and position of the virtual point sources are equally important. Alignment was accomplished using alignment telescopes, theodolites, and machined alignment fixtures. The position of the holographic substrate as well as angular alignment is also important. This was accomplished using alignment telescopes and machined alignment fixtures. The beam steering mirrors were placed so as to equal pathlengths of the object and reference beams.

6.1.3 Holographic Process

Critical steps in the conversion of the exposed dichromated gelatin film coating into an efficient diffraction element at the proper wavelength include:

1. Development
2. Efficiency enhancement

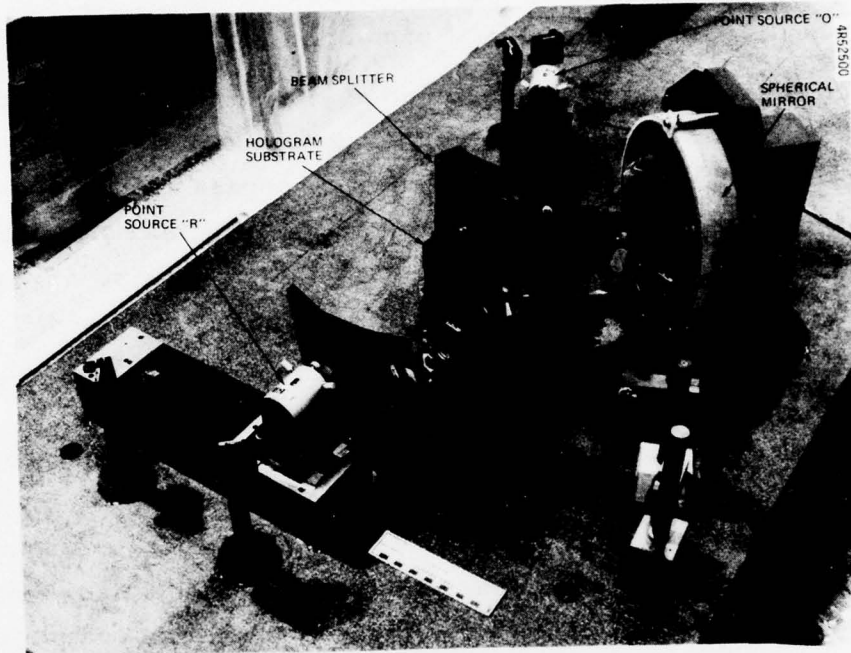

482499

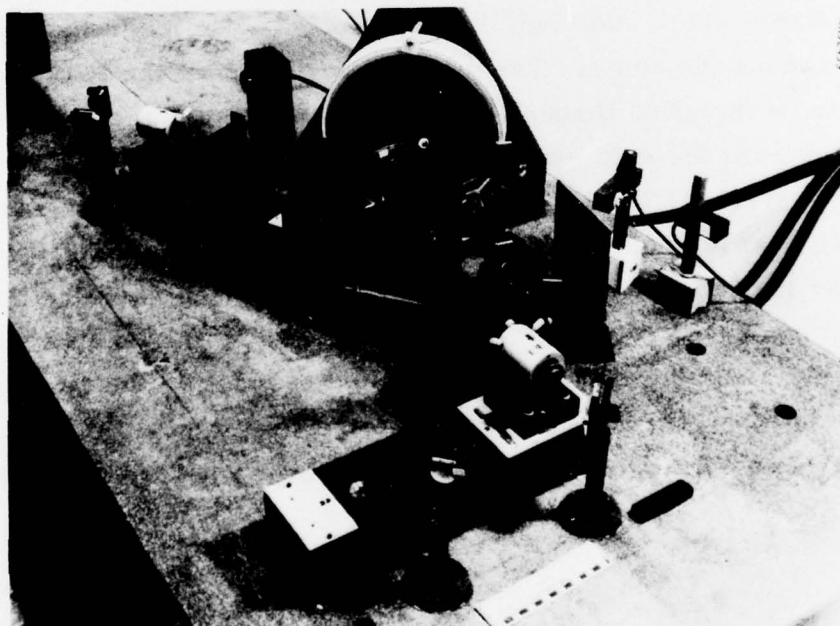

Figure 6-1. Construction optics.

3. Wavelength adjustment
4. Stabilization
5. Sealing for environmental protection

The efficiency of a diffraction element is a function of the exposure level as well as the development and efficiency enhancement processes. The efficiency of the hologram determines both the bandpass and the see-through properties of the hologram. It was decided that a particularly high see-through or narrow bandpass was not required on this program. Therefore, the reflection efficiency of the diffraction elements was optimized.

6.2 RELAY OPTICS HOUSING

The relay optics housing is planned to be molded in two halves. Each half contains two lens groups, two mirrors at compound angles, the exit window and the mounting for the fiber light pipe. To fabricate a small quantity, molds will be made to make wax mandrels upon which glass reinforced plastic will be coated in a number of thin layers to form the complete housing shell and locate with precision all the optical mounting surfaces. Large quantities would be injection molded. Plastic material is designed to keep the weight to a minimum, although the first unit may be made from machined aluminum to reduce the costs. The design allows for all the lens elements and spacers to be installed through the mounting hole of the second mirror, the second fold from the exit window end of the assembly. The mirrors, lens and windows will be bonded in place. The mirrors, window and fiber bundle housing seal the housing to keep all the optical surfaces clean. The surfaces of the two halves that join together will be machined, locating pins, bosses, and flanges will provide the means for holding the two halves together and provides the mounting surfaces and method of locating the optical centerlines of the completed assembly. The completed assembly will be accurately located to the helmet bracket, using optical tooling, and fastened to it by screws.

7.0 WIDE FIELD OF VIEW DESIGN

7.1 WIDE FIELD OF VIEW REQUIREMENTS

It was expressly desired at the final design review that the BHHD optical design be altered to increase the horizontal field of view. Exact requirements were not established. The intent of the effort was to develop requirements based on optical performance and physical constraints. It was desired that a total field of view of 40 degrees be a goal. This might be obtained by designs with a) total overlapping fields of view or with b) fields overlapping as little as ten degrees. As an aid to the design it was suggested that the vertical field of view could be limited to 15 degrees.

7.2 OPTICAL CONSIDERATIONS

The current BHHD design covers a 15-degree FOV which it is desirable to increase as far as reasonable without severely impacting the resolution or human factors aspects of the display. However, no optical design trade-offs have been performed to establish the largest FOV that can be obtained. Therefore, engineering judgement and experience on related programs must be used to estimate the obtainable FOV at the present time.

From the point of view of optical design, diffraction optics displays can certainly be designed with fields of view up to 30 by 40 degrees. The most applicable existing design is the Holographic One Tube Goggle (HOTG) designed and built for Night Vision Laboratories in 1977. The optical characteristics of the BHHD and HOTG designs are compared in Table 7-1. The principal differences in the design are the display size at the fiber optics, the eye relief, and the hologram focal length. To maintain an approximately

F/2 system, the increased fiber optic size is, of course, essential for a larger FOV. To increase the FOV from this point of view, a faster optical system is necessary, perhaps also with a modest increase to the fiber optics diameter. To obtain a 20-degree FOV requires an F/1.5 system with the same fiber optics diameter; to achieve this, the relay lens speed is close to F/1 requiring at least the addition of another element, and probably the aspherizing of one or more surfaces in the relay. To further increase the FOV probably will require larger fiber optics.

In comparison with the HOTG design, it should be noted that the shorter BHHD hologram EFL implies relatively large hologram aberrations. The increased BHHD FOV may also require a larger bend angle which will further complicate the system and impact resolution. Taking these factors into account, one may arrive at the following conclusions. A modest FOV increase from 15 to 20 degrees can be reasonably expected after redesign in the current basic configuration, but to achieve a 25-degree FOV involves

TABLE 7-1. COMPARISON OF BHHD AND HOTG OPTICAL CHARACTERISTICS

Parameter	Value	
	BHHD	HOTG
Pupil dia., mm	12	12
Object surf. dia., mm	7.2	18
FOV, degrees	15	30V x 40H
EFL, mm	27.3	24.7
F-number	2.3	2.06
Eye relief, mm	71.1	88.9
Hologram EFL, mm	38.1	50.8
Bend angle, degrees	50	50
Relay F-number	1.3	1.4

some risk. To go further will probably require major changes to the configuration, such as increasing the eye relief and hologram focal length, resulting in a system similar to the HOTG design. In this case, the optical system will be less compatible with the current visor and helmet.

7.3 PHYSICAL DESIGN CONSIDERATIONS

The Holographic One-Tube Goggle optical design was considered as a wide field of view baseline design. Its field of view is 30 degrees horizontal and 30 degrees vertical for each eye. Figure 7-1 shows a computer ray trace for this system. The eye relief is 3.5 inches with an exit pupil of 12 mm. What must be done to adapt this design, is reduce the eye relief to approximately 2.8 inches and maintain the exit pupil diameter at 12 mm. This optical design assumes that the lenses and fiber light pipe will increase in size over that of the current BHHD design. As a first approximation, it was decided to try to adapt the HOTG design physically to the helmet by scaling down all linear dimensions. The result of the preliminary design is shown in Figure 7-2. The plane of symmetry of the hologram was rotated approximately 41 degrees from the vertical, so that the optical paths cross at the center of the forehead. The layout shows that the lenses will fit. The main problem area is the exit window size required. This is the window sealing the optics from dust, shown dotted in the layout. It crosses over the centerline of the design which means it will interfere with its like component for the other eye. This problem can potentially be solved by 1) sealing the optics by a tilted flat piece of glass used in common by both optical systems, 2) by sealing at the first lens element, thus exposing the mirror to the environment or 3) using a prism as the first element in place of the flat mirror, thus separating each system entirely from the other. The ray traces that show this problem will probably be less of a problem than depicted here for several reasons; 1) the horizontal 40-degree field of view will be rotated with respect to the plane of symmetry, 2) the

TA 3963

OPTICAL CHARACTERISTICS	
CHARACTERISTICS	VALUE
FIELD OF VIEW, DEGREES	40 HORIZ x 30 VERT, ELLIPTICAL
EXIT PUPIL DIAMETER, INCH	0.47
FOCAL LENGTH, INCH	0.97
F-NUMBER	2.06
IIT DIAMETER, INCH	0.71
WAVELENGTH, NM	543.0

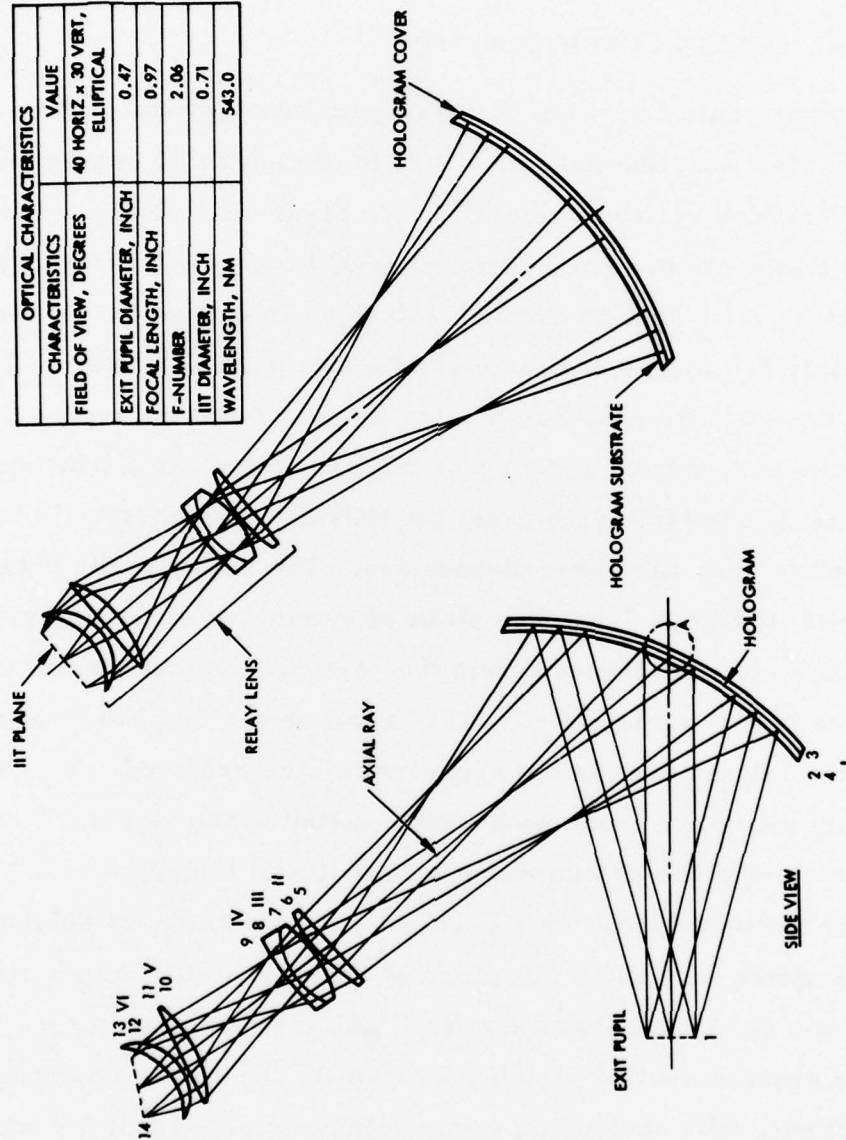

Figure 7-1. Computer raytrace of unfolded, feasibility model One-Tube Goggle optical system.

TA/4762

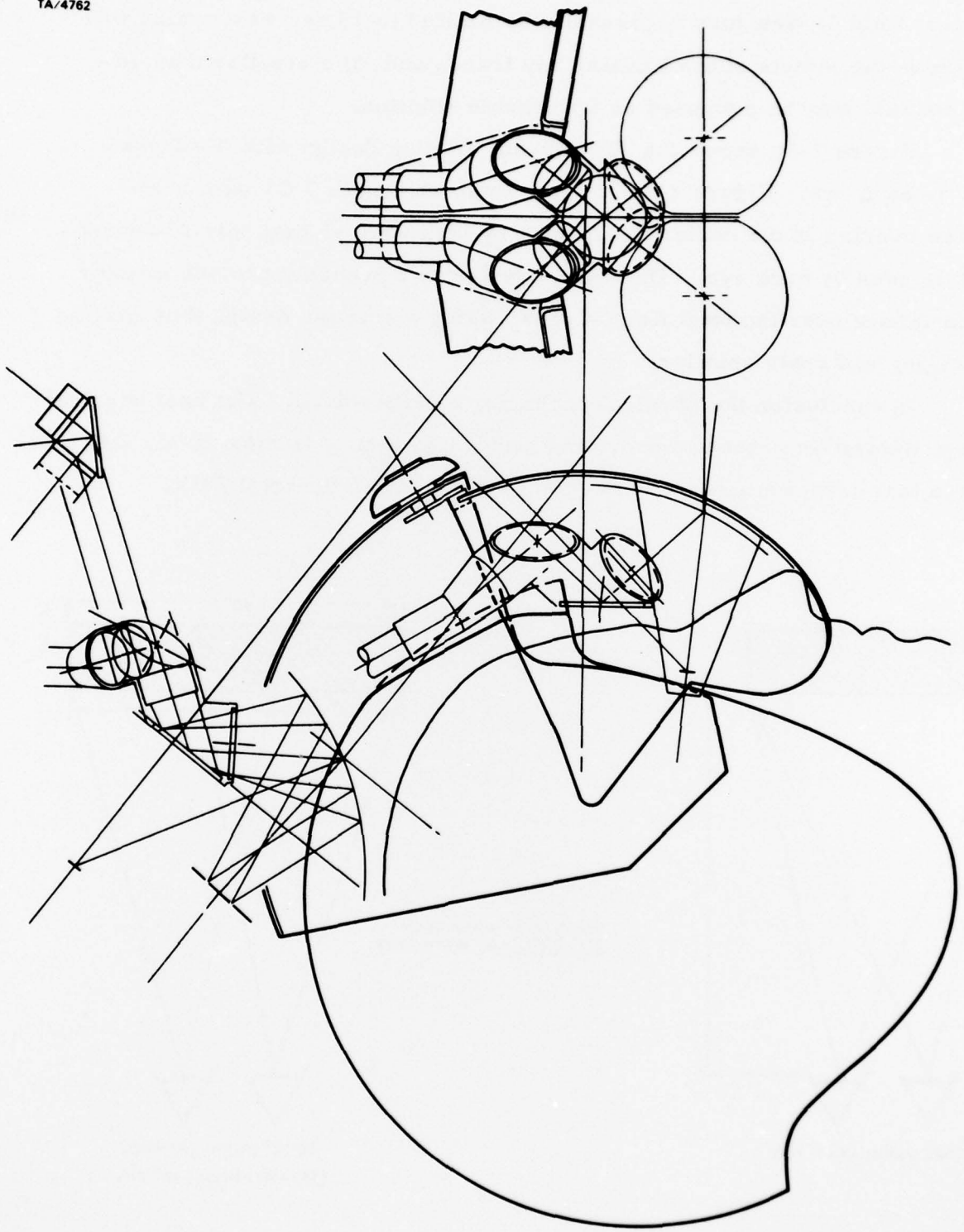

Figure 7-2. Preliminary wide FOV layout.

vertical field of view may necessarily be limited to 15 degrees, which will minimize the effects of the limiting ray traces and 3) a smaller than 40-degree field may be proposed as a workable solution.

Figure 7-3a shows the 100 percent overlap design with 40-degree FOV to each eye. Figure 7-3b shows a total 40-degree FOV with a 10-degree overlap in the center field, seen by both eyes so that only 25 degrees FOV is seen by each eye. This latter design will probably provide greater performance over the total field of view, using a smaller design thus making packaging and costs smaller.

In conclusion the physical packaging can be solved. The best physical design minimizing cost and providing best performance is most likely the design that uses a small percentage of overlap within the total FOV.

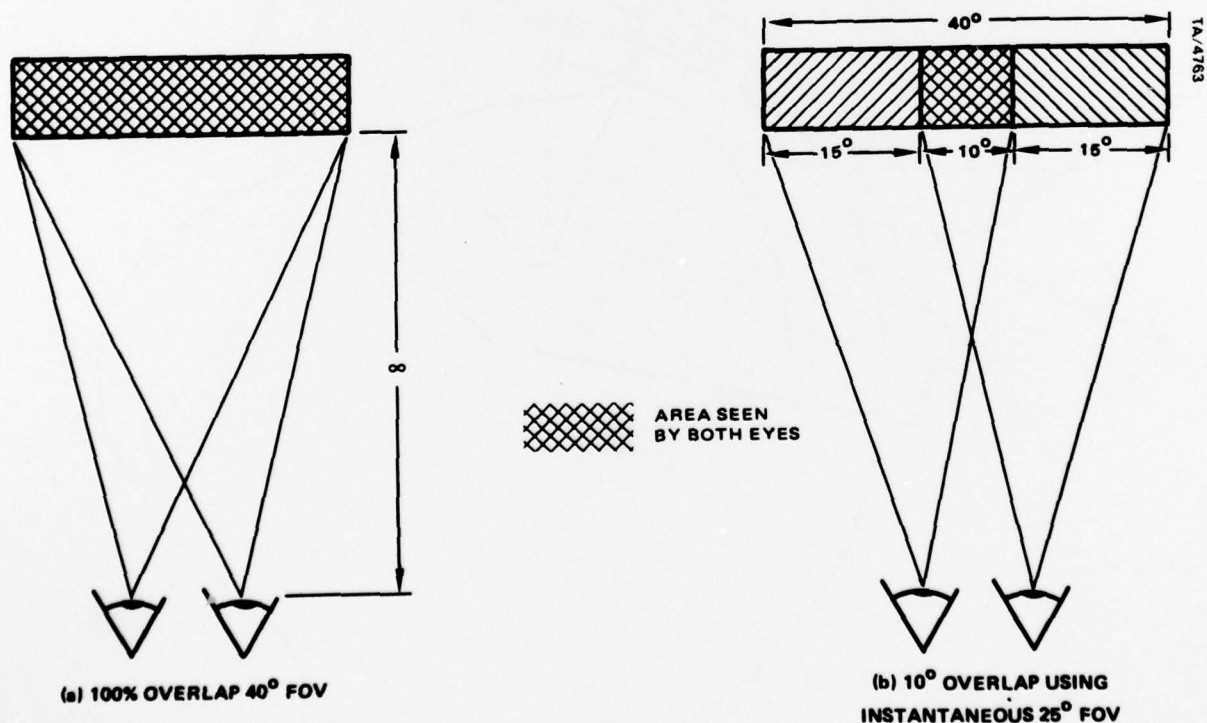

Figure 7-3. Field of view schemes.

8.0 CONCLUSIONS

8.1 ACCOMPLISHMENTS

A successful binocular design has been developed for viewing of a dual image source using holographic combiners on the visor of a standard Navy HGU-33 helmet.

This accomplishment can be summarized by reviewing three distinct technical areas 1) the optical design, 2) the physical design, and 3) the holographic fabrication. The optical and physical design developments were directly interrelated and accomplished by successive iteration to insure physical compatibility with the helmet.

8.1.1 Optical Design Accomplishments

The final optical design incorporates a relay lens system that is symmetric to the normal of the hologram surface. This design provides an exit pupil of 12 mm, eye relief of 2.80 inches, a field of view to each eye of 15 degrees, mating with a fiber light pipe diameter of 8 mm. The system design optical performance over the field of view is very good with a bend angle at the hologram of 50 degrees. Final computer optimization is expected to further improve the optical performance.

A wider field of view design existing for a binocular goggle application has been reviewed to determine if it is adaptable to BHHD. Significant changes in the relay lens and hologram design would be required. This includes reducing the eye relief of the goggle design from 3.5 inches to

2.8 inches, while maintaining the exit pupil at 12 mm, and changing the hologram radius of curvature from 3.5 inches to approximately 4.5 inches. The design provides a 40-degree field of view of each eye, but the above changes may not produce the performance required. An alternative approach suggested is to narrow the field of view to each eye and provide a small field of view overlap, so that the total field of view is maintained at approximately 40 degrees.

The initial optical design effort involved preliminary investigation of four basic approaches: 1) a system without relay lens where the fiber light pipe is the direct image source for the holographic combiner, 2) a design with no relay lens system, but with corrective lenses employed to better match the fiber light pipe image to that required by the hologram, 3) a system with a relay lens that is asymmetric with respect to the normal of the hologram surface providing minimum packaging restraints, and 4) the system using a relay lens that is symmetric to the normal of the hologram surface. The symmetric system with relay lens demonstrated, by first order calculations, superior performance values and was therefore selected for the final optical design.

8.1.2 Physical Design Accomplishment

The physical design of BHHD was an iterative process. To aid in the design effort a computer program was developed to include the standard head, the hologram surface, the relay lens elements, and folding mirrors. The computer printout of the configuration showed ray traces in side, top, and front views. This tool was invaluable for assessment of small changes to the optical system as they were made. A crossover design, in which the relay system for the right eye is on the left side of the head, and vice versa was selected to provide the minimum bend angle at the hologram of 50 degrees and the minimum look-up angle visual obscuration. The packaging of the relay is very compact with the incorporation of a second folding

mirror. Several methods of accurate registration of the hologram to the relay systems were investigated. The best solution is the method of accurate positioning of the holograms to the visor using specialized optical tooling; strengthening and supporting the visor by use of a frame; and mounting and aligning the visor and relay lens housing to a bracket that wraps around the front of the helmet and is adjustable to the helmet for fitting to specific operator requirements.

8.1.3 Hologram Fabrication

During this program small holograms typical of those required for BHHD application were exposed, developed, and processed to completion. They were fabricated on glass as the substrate material best suited to maintain the stability of the optical characteristics of the hologram. These were mounted on a helmet visor installed on an HGU-33 helmet.

8.2 RECOMMENDATIONS FOR FUTURE PROGRAM

A successful design for binocular viewing of a dual image source using holographic combiners on the visor of a standard Navy HGU-33 helmet has been developed. The field of view is 15 degrees. Preliminary investigation into the adaptation of an existing wide field of view (up to 40 degrees horizontal) design, showed that with changes, it appears promising that a combined physical and optical design effort could produce a system that would meet high optical performance and provide the wider field of view desired. The design effort must include tradeoffs of fully overlapping FOVs, and partial overlapping FOVs and an investigation into the distortion produced by various radius of curvatures of the visor. The preliminary design layout adapting the existing One-Tube Goggle design showed that, though significant modifications to the BHHD configuration may be required, physical compatibility with the helmet and visor appears feasible. Only one significant interference problem with the exit window was apparent.

This type of problem is typical for this type of design effort and does not require state of the art development.

It is therefore recommended that continued development of the BHHD include the following: 1) optical design for a wider field of view system, 2) mechanical design for the wider field of view, 3) fabrication of a complete WFOV/BHHD for demonstration and test of system performance and mechanical operation and acceptance.