

AD-A062 773

MASSACHUSETTS INST OF TECH CAMBRIDGE ELECTRONIC SYST--ETC F/6 12/1
A FUNCTIONAL EXPANSION APPROACH TO THE SOLUTION OF NONLINEAR FE--ETC(U)
OCT 78 R P SINGH, T L JOHNSON AFOSR-77-3281

UNCLASSIFIED

ESL-P-796

AFOSR-TR-78-1546

NL

| OF |
AD
A062773



END
DATE
FILMED
3-79
DDC

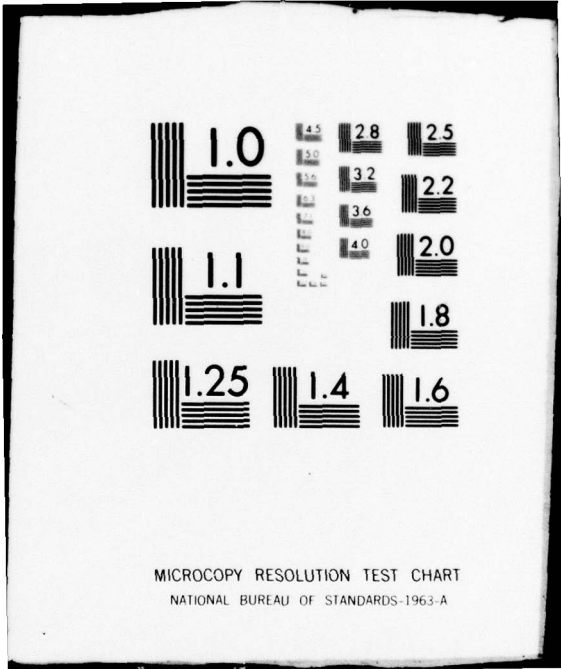

MICROCOPY RESOLUTION TEST CHART
NATIONAL BUREAU OF STANDARDS-1963-A

19 REPORT DOCUMENTATION PAGE		READ INSTRUCTIONS BEFORE COMPLETING FORM	
1. REPORT NUMBER 18 AFOSR-TR-78-1546	2. GOVT ACCESSION NO.	3. RECIPIENT'S CATALOG NUMBER 2	4. TITLE (and Subtitle) 6 A FUNCTIONAL EXPANSION APPROACH TO THE SOLUTION OF NONLINEAR FEEDBACK SYSTEMS
7. AUTHOR(s) 10 Ram-Nandan P./Singh and Timothy L./Johnson	8. CONTRACT OR GRANT NUMBER(s) AFOSR-77-3281 NSF-77-05200	5. TYPE OF REPORT & PERIOD COVERED Interim Rept.	6. PERFORMING ORG. REPORT NUMBER ESL-P-796
9. PERFORMING ORGANIZATION NAME AND ADDRESS Massachusetts Institute of Technology Lab. for Information & Decision Science Cambridge, MA 02139	10. PROGRAM ELEMENT, PROJECT, TASK AREA & WORK UNIT NUMBERS 61102F 16 2304/A1 17 A1	11. CONTROLLING OFFICE NAME AND ADDRESS Air Force Office of Scientific Research/NM Bolling AFB, Washington, DC 20332	12. REPORT DATE 11 October 1978
14. MONITORING AGENCY NAME & ADDRESS (if different from Controlling Office)	15. SECURITY CLASS. (of this report) UNCLASSIFIED	13. NUMBER OF PAGES 6 12 7p.	15a. DECLASSIFICATION/DOWNGRADING SCHEDULE
16. DISTRIBUTION STATEMENT (of this Report) Approved for public release; distribution unlimited.			
17. DISTRIBUTION STATEMENT (of the abstract entered in Block 20, if different from Report)			
18. SUPPLEMENTARY NOTES DDC JAN 4 1979 RECEIVED			
19. KEY WORDS (Continue on reverse side if necessary and identify by block number) F THIS DOCUMENT IS BEST QUALITY PRACTICABLE. THE COPY FURNISHED TO DDC CONTAINED A SIGNIFICANT NUMBER OF PAGES WHICH DO NOT REPRODUCE LEGIBLY.			
20. ABSTRACT (Continue on reverse side if necessary and identify by block number) This paper presented two results: (i) a new structure for the solution of nonlinear analytic systems, and (ii) an application of Bellman's Fundamental Technique to obtain the sub-optimal-feedback control of a class of quasilinear systems with non-quadratic performance indices. The application of the Fundamental Technique with a nonlinear auxiliary equation is shown to result in higher order approximating equations which are linear. Using the method by separation of variables, two examples are solved.			

AD A062773

DDC FILE COPY

127 200

JOB

DISCLAIMER NOTICE

**THIS DOCUMENT IS BEST QUALITY
PRACTICABLE. THE COPY FURNISHED
TO DDC CONTAINED A SIGNIFICANT
NUMBER OF PAGES WHICH DO NOT
REPRODUCE LEGIBLY.**

AFOSR-TR- 78 - 1546

To be presented at the CDC in San Diego
January, 1979.

A FUNCTIONAL EXPANSION APPROACH TO THE SOLUTION OF NONLINEAR FEEDBACK SYSTEMS*

Ram-Nandan P. Singh
Timothy L. Johnson

Laboratory for Information and Decision Systems
Department of Electrical Engineering and Computer Science
Massachusetts Institute of Technology
Cambridge, Massachusetts 02139

Abstract

This paper presents two results: (i) a new structure for the solution of nonlinear analytic systems, and (ii) an application of Bellman's Fundamental Technique to obtain the sub-optimal-feedback control of a class of quasilinear systems with non-quadratic performance indices. The application of the Fundamental Technique with a non-linear auxiliary equation is shown to result in higher order approximating equations which are linear. Using the method by separation of variables, two examples are solved.

1. Introduction

The determination of an optional feedback control law for a nonlinear systems is an important problem in engineering. The method of dynamic programming yields the feedback solution directly. Unfortunately this method reduces the problem to solving a nonlinear partial differential equation. This is a complex problem, in general. However, the solutions of feedback problems for linear finite-dimensional systems with a quadratic criterion (known as L-Q problems) are available [1-3]. A more difficult problem than the usual L-Q problem has been mentioned by Anderson and Moore [3-p.22], and Moylan and Anderson [4]. The solutions of the nonlinear partial-differential equations resulting from the applications of dynamic programming to such problems are unresolved in general. However, for this particular problem [3], which involves a linear system with a non-quadratic performance index, the exact solution is available [5]. The close examination of this analytical solution reveals the complexity both in deriving the exact feedback law as well as in implementing it.

In this paper, a method is developed to obtain an asymptotic solution of the feedback laws for more general problems.

2. Problem and Detailed Analysis

$$\dot{x} = Ax + Bu + \psi(x) + \sum_{i=1}^n e_i U N_i f(x); \quad x(t_0) = x_0 \quad (1)$$

*This research has been supported by the National Science Foundation, Grants NSF 77-05200 and NSF 77-2844, and the U.S. Air Force Office of Scientific Research, Grant 77-3281.

$$\min J[U] = \int_{t_0}^{t_f} (U^T U + g(x)) dt \quad (2)$$

where for $t_0 \leq t \leq t_f$, $U(t) \in U$; $\psi(x)$ and $f(x)$ are vector polynomials in x ; A and B are n by n and n by r matrices respectively. $N_i (i=1,2,\dots,n)$ are matrices representing mappings defined as follows: $N_i: R^n \rightarrow R^r$. The vectors $e_i (i=1,2,\dots,n)$ are the standard basis vectors; and $g(x)$ is an entire function of x , in general.

$$\text{Let } F_1(x,u) \triangleq \psi(x) + \sum_{i=1}^n e_i U N_i f(x)$$

Assumption (A): Assume that $F_1(x,u)$ satisfies the following conditions:

(i) The nonlinear function $F_1(x,u)$ is continuous and its first partial derivatives are also continuous.

(ii) $\lim_{|x| \rightarrow 0} \psi(x) = 0$; $\lim_{|x| \rightarrow 0} F_1(x) = 0$ uniformly for $t \in [t_0, t_f]$ $\|F_1(x,u)\|$

(iii) $\lim_{\|(x,u)\| \rightarrow 0} \frac{\|F_1(x,u)\|}{\|(x,u)\|} = 0$ uniformly for $t \in [t_0, t_f]$

where, $(x,u) \in C$, and C denotes the Banach space of continuous functions $(x,u): [t_0, t_f] \rightarrow R^n \times R^r$ with the usual sup norm,

$$\|(x,u)\| = \sup_t \left\{ \sum_{i=1}^n |x_i(t)| + \sum_{j=1}^r |u_j(t)| : t \in [t_0, t_f] \right\}$$

$$\|F_1(x,u)\| = \sup_t \left\{ \sum_{i=1}^n |F_{1i}(x(t), u(t))| \right\}$$

(iv) The linear time-invariant system

$$\dot{\bar{x}} = A \bar{x} + B \bar{U}; \quad \bar{x}(t_0) = \bar{x}_0$$

is uniformly completely controllable in the sense of Kalman [7] for bounded coefficients A and B . Here the over-bar denotes variables corresponding to the linear part of system (1) only.

If all the conditions cited above are satisfied by system (1), then the quasilinear system (1) is uniformly controllable [8].

Assumption (B): Assume that $g(x)$ satisfies the following conditions:

78 12 21 075

- (i) $g(x)$ is even and positive in x ,
(ii) $g(x)$ is continuous and its first derivative is also continuous and monotonically increasing for positive x .
(iii) $\lim_{|x| \rightarrow 0} g(x) = 0$ uniformly for $t \in [t_0, t_f]$
(iv) $g(x)$ is analytic in x .

Now we apply the method of dynamic programming to system (1-2) in order to obtain the optimal feedback law for the system.

The basic Hamilton-Jacobi equation for the above system can be written [3] as

$$\frac{\partial V}{\partial t} = - \min_{U(t)} \{ U^T U + \frac{\partial V^T}{\partial x} [Ax + BU + \psi(x) + \sum_{i=1}^n e_i U^T N_i f(x)] \} \quad (3)$$

$$V(x(t_f), t_f) = 0 \quad (4)$$

where the function $V(x(t), t)$ is assumed to be a scalar function satisfying the conditions on Liapunov's Theorem on asymptotic stability [6], and is twice continuously differentiable.

It can be shown that the minimizing control for equation (3) is given by

$$U^* = - \frac{1}{2} [B^T \frac{\partial V}{\partial x} + (\sum_{i=1}^n N_i \frac{\partial V}{\partial x_i}) f(x)] \quad (5)$$

assuming the above inverse exists. Compactly, we can write the above expression as

$$U^*(x) = G[V(x)] \quad (6)$$

where G represents the optimal feedback operator. Substituting equation (5) into equation (3), we get

$$\begin{aligned} - \frac{\partial V}{\partial t} = & - \frac{1}{4} \frac{\partial V^T}{\partial x} B B^T \frac{\partial V}{\partial x} + \frac{\partial V^T}{\partial x} Ax + g(x) + \frac{\partial V^T}{\partial x} \psi(x) \\ & + \frac{1}{4} \left(\sum_{i=1}^n \frac{\partial V}{\partial x_i} f^T(x) N_i^T \right) B^T \frac{\partial V}{\partial x} - \frac{3}{4} \frac{\partial V^T}{\partial x} B \cdot \\ & \left(\sum_{i=1}^n \frac{\partial V}{\partial x_i} N_i f(x) \right) \\ & - \frac{1}{4} \left(\sum_{j=1}^n \frac{\partial V}{\partial x_j} \right) \left(\sum_{i=1}^n \frac{\partial V}{\partial x_i} f^T(x) N_i^T \right) N_j f(x); \end{aligned} \quad (7)$$

with the terminal condition $V(x(t_f), t_f) = 0$. (8)

The differential system (7)-(8) is called Hamilton-Jacobi-Bellman (H-J-B) equation and represents a first order partial differential equation with one dependent variable $V(x, t)$, and two independent variables x and t .

The results can be summarized as follows.

Theorem 1. Let the quasilinear systems (1)-(2) satisfy assumption (A) and (B). Then the optimal feedback control for the system is given by (5) after solving (7).

Obviously, equation (7) is a nonlinear first

order partial-differential equation. Under the assumptions (A) and (B), the Cauchy-Kowaleski Theorem [9] guarantees a unique local analytic solution of equation (7). However, in general, the solution of equation (7) cannot be obtained in a closed form.

Since the solution of equation (7) is analytic, the Cauchy-Kowalewski Theorem motivates the application of a regular perturbation expansion of the complete solution to obtain the approximate solution.

3. The Bellman Fundamental Technique

Thus, to obtain the optimal feedback solution $U^*(x)$, we have to solve equation (7) with the terminal condition (8). In this section, we apply Bellman's Fundamental Technique [10;p.2] to the solution of Hamilton-Jacobi-Bellman equation (7) but using a nonlinear (rather than linear) auxiliary equation. The philosophy behind the Fundamental Technique has been explained by Bellman [10] for the solution of nonlinear problems using a standard equation (called auxiliary equation which is linear and whose solution already is well known. The central idea of the Fundamental Technique was thus demonstrated by obtaining an infinite set of linear equations as a solution to the given nonlinear problem.

In this paper, the solution of a nonlinear system is desired using a nonlinear auxiliary equation whose solution is well-known. The method yields an infinite set of linear equations as an equivalent solution to the original problem. The salient features of the solution obtained are the following: (i) the first approximating equation is nonlinear and has structure similar to that of the auxiliary equation, (ii) the subsequent approximating equations are linear equations; and (iii) all the equations are recursively connected.

The motivation for extending the application of the Fundamental Technique using a nonlinear auxiliary equation lies in the fact that the form of the nonlinear auxiliary equation used in the technique is closer to the form of the nonlinear problem (which is to be solved) than any form of linear auxiliary equation. Hence this should yield more rapidly convergent approximations to the exact solution. Further, the results of the linear quadratic theory (L-Q Theory) can be exploited to achieve this goal.

Now we define some notation which is to be used in the analysis which follows.

Define nonlinear operators H and G as

$$H: V \rightarrow G;$$

where

$$V: R^n \times [t_0, t_f] \rightarrow R; G: R^n \rightarrow R$$

$$H: C[R^n \times [t_0, t_f]] \rightarrow C^\infty[R^n]$$

Consider a nonlinear system characterized by

$$H[V] = G \quad (9)$$

Assume the nonlinear operator H is analytic in V and is thus continuously differential with respect to $V(\cdot)$.

78 · 12 21 075

The function $V(x)$, we have in mind, is the solution of equation (9).

Assume an auxiliary equation with appropriate boundary conditions:

$$H_1[V] = G_1 \quad (10)$$

whose solution is known. For example, this auxiliary equation may have a form whose solution can be found using a Riccati equation or Bernoulli equation or some other known nonlinear equations. In general, the auxiliary equation may be linear or nonlinear. The application of the Fundamental Technique using a linear auxiliary equation has already been presented [10]. Here we shall deal with a nonlinear auxiliary equation in the Fundamental Technique. In general, the highest degree of nonlinearity present in the auxiliary equation may be the same (if possible) or lower than that of the original nonlinear equation (9).

Using equation (10), we can rewrite equation (9) as

$$H_1[V] + [H[V] - H_1[V]] = G_1 + [G - G_1]$$

or

$$H_1[V] = G_1 + H_2[V], \text{ where the expression}$$

$$H_2[V] \triangleq [H[V] - H_1[V] + G - G_1] \quad (11)$$

Introduce a small positive artificial parameter ϵ in the above expression. Here ϵ is a parameter whose nominal value is one. This is basically a perturbation parameter that can enter the expression (11) in various combinations and powers of ϵ as demanded by a particular problem. The placing of ϵ in (11) offers high manipulating power to the Fundamental Technique for solving complex nonlinear problems. In general, the introduction of this small positive perturbation parameter may be necessary even though the system equation (9) may contain one or more small positive system parameters. However, in special cases, the role of this perturbation parameter may be played by a small positive physical parameter that may enter the system naturally.

For brevity of presentation, let us introduce this artificial parameter in the following form:

$$H_1[V] = G_1 + \epsilon H_2[V] \quad (12)$$

Thus, this is the required format of the Fundamental Technique.

Since the nonlinear system (11) has been assumed to be analytic in $V(\cdot)$, the solution function can be expressed as

$$V = V_0 + \epsilon V_1 + \epsilon^2 V_2 + \dots + \epsilon^n V_n + \dots \quad (13)$$

where $V_0, V_1, \dots, V_n, \dots$ are independent of ϵ . For fixed V_0, V_1, V_2, \dots , the nonlinear operator $H_2[\cdot]$ itself becomes an ordinary function [11] of ϵ . Thus

$$f_2(\epsilon) = H_2[V]$$

At the same time $f_2(\epsilon)$ is also analytic in ϵ and hence it can be expanded as a Taylor's series about $\epsilon=0$. This yields a power series in ϵ as given below:

$$f_2(\epsilon) = H_2(V_0 + \epsilon V_1 + \epsilon^2 V_2 + \dots; x) = N_0(V_0, x) + \epsilon N_1(V_0, V_1; x) + \dots \quad (14)$$

where N_0, N_1, \dots are Taylor's series coefficients of the functional $H_2[V]$, and can be also obtained by constructing a power series of $H_2(V)$ in ϵ .

Now we proceed to obtain an expansion of the functional $H_1[V]$ in ϵ . Since $H_1[V]$ is analytic in ϵ [11] for fixed $V_0, V_1, V_2, \dots, V_n, \dots$, this functional becomes an ordinary function of ϵ . Thus

$$f_1(\epsilon) = H_1[V_0 + \epsilon V_1 + \epsilon^2 V_2 + \dots] \quad (15)$$

is analytic in ϵ about $\epsilon=0$.

The Taylor's series expansion of a functional has been constructed by Volterra [11;p.24] and he called the expansion an "Extension of Taylor's Theorem" to a class of functionals. Exploiting his ideas, we state a lemma as follows:

Lemma 1: Assuming the functional is continuous and differentiable on a class of functions over the interval $[a, b]$. Then the Taylor's series expansion of the functional $H_1[V(t)]$ can be expressed as

$$H_1[V] = H_1[V_0] + \epsilon L_1[V_1] + \epsilon^2 L_2[V_2] + \dots + \epsilon^n L_n[V_n] + \dots \quad (16)$$

where

$$H_1[V_0], L_1[V_1], \dots, L_n[V_n], \dots$$

are the Taylor's series coefficients having the following properties: $H_1[V_0]$ is a nonlinear function of V_0 ; $L_1[V_1]$ is a linear function of V_1 ; $L_2[V_2]$ is a linear function of V_2 ; and so on.

Proof: We calculate terms of the Taylor's series expansion of a functional as defined by Volterra [11;p.24].

The first term is given by

$$H_1[V] \Big|_{\epsilon=0} = H_1[V_0] \quad (i)$$

The second term has been defined as

$$\left(\frac{d}{d\epsilon} H_1[V_0 + \epsilon\phi] \right) \Big|_{\epsilon=0} = \int_a^b H'_1[V_0 + \epsilon\phi; \xi_1] \frac{\partial \phi(\xi_1)}{\partial \epsilon} d\xi_1 \Big|_{\epsilon=0}$$

where $H'_1[V]$ denotes the first derivative of the functional with respect to V at the point ξ_1 . Here ξ_1 is a parameter which varies continuously within $[a, b]$; and in our case,

$$\phi \triangleq V_1 + \epsilon V_2 + \epsilon^2 V_3 + \dots \quad (17)$$

Substituting the value of ϕ in the above expression and evaluating at $\epsilon=0$, we get

$$\left(\frac{d}{d\epsilon} H_1[V_0 + \epsilon\phi]\right)_{\epsilon=0} = \int_a^b H_1'[V_0; \xi_1] V_1(\xi_1) d\xi_1 \quad (ii)$$

Clearly for a given V_0 , we write (ii) as a linear function of V_1 . Thus

$$L_1[V_1] = \int_a^b H_1'[V_0; \xi_1] V_1(\xi_1) d\xi_1.$$

Similarly, we have the third term

$$\left(\frac{d^2}{d\epsilon^2} H_1[V]\right)_{\epsilon=0} = \int_a^b \int_a^b H_1''[V_0; \xi_1, \xi_2] V_1(\xi_1) V_1(\xi_2) d\xi_1 d\xi_2 + 2! \int_a^b H_1'[V_0; \xi_1] V_2(\xi_1) d\xi_1 \quad (iii)$$

For given V_0 and V_1 , (iii) is a linear function of V_2 . Q.E.D.

Theorem 2 Assume that the auxiliary equation (10) has a known form of solution. The nonlinear system (9) can be imbedded into an infinite set of recursive equations with appropriate boundary conditions:

$$\begin{aligned} H_1[V_0] &= G_1 \\ L_1[V_1] &= N_0[V_0;] \quad n = 1, 2, \dots \\ L_2[V_2] &= N_1[V_0, V_1;] \\ &\dots \\ L_n[V_n] &= N_{n-1}[V_0, V_1, \dots, V_{n-1};] \end{aligned} \quad (18)$$

Proof: Using Lemma (1) and equation (14), we can write nonlinear system (9) in its standard format (12). Equating coefficients of ϵ^n , equation (18) follows.

Equation (18) represents the basic structure of the solution of a nonlinear system using a nonlinear auxiliary equation in the Fundamental Technique. This has been schematically represented in Figure 1.

The following steps are involved in the method:

1. Choose an auxiliary equation (10).
2. Define a nonlinear function $H_1[V]$ (11).
3. Put the problem in the format (12).
4. Obtain equation (18) starting from equation (12).
5. Solve equation (18) and plug the solution into equation (13).

4. The Application of the Method

We shall apply the methodology of the Fundamental Technique to solve the nonlinear systems (7) and (8).

From the knowledge of L-Q Theory, it is well-known that

$$\frac{1}{4} \frac{\partial V^T}{\partial x} B B^T \frac{\partial V}{\partial x} - \frac{\partial V^T}{\partial x} A x - \frac{\partial V}{\partial t} = x^T Q x; \quad \bar{V}(x(t_f), t_f) = 0 \quad (20)$$

has a solution of the form

$$V(x(t), t) = x^T K(t) x \quad (21)$$

Here Q is a positive definite matrix which is known, and $K(t)$ is a symmetric matrix satisfying

the Riccati matrix equation

$$\dot{K} = K B B^T K - (KA + A^T K) - Q; \quad K(t_f) = 0 \quad (22)$$

Assuming equation (20) to be an auxiliary equation for the solution of nonlinear equation (7), we can apply the Fundamental Technique to obtain the solution of equation (7).

Now observe that the term $x^T Q x$ is not present in equation (7). Hence we shall add and subtract this term in equation (7) in order to obtain an equation with the standard format (12). Thus equation (7) can be converted to the form of equation (12) as follows.

$$\frac{1}{4} \frac{\partial V^T}{\partial x} B B^T \frac{\partial V}{\partial x} - \frac{\partial V^T}{\partial x} A x - \frac{\partial V}{\partial t} = x^T Q x + \epsilon H_2(V, x); \quad V(x(t_f), t_f) = 0 \quad (23)$$

where

$$\begin{aligned} H_2(V, x) &\triangleq g(x) - x^T Q x + \frac{\partial V^T}{\partial x} \psi(x) - \frac{1}{4} \left(\sum_{j=1}^n \frac{\partial V}{\partial x_j} \right. \\ &\left. \left(\sum_{i=1}^n \frac{\partial V}{\partial x_i} f^T(x) N_i^T \right) N_j f(x) \right) + \frac{1}{4} \left(\sum_{i=1}^n \frac{\partial V}{\partial x_i} f^T(x) N_i^T \right) \\ &\left. B^T \frac{\partial V}{\partial x} - \frac{3}{4} \frac{\partial V^T}{\partial x} B \left(\sum_{i=1}^n \frac{\partial V}{\partial x_i} N_i f(x) \right) \right]. \end{aligned} \quad (24)$$

Now we can substitute equation (13) in equation (23) and equate the coefficients of various powers of ϵ . Using equation (18), the following equations are obtained:

$$\begin{aligned} \epsilon : \quad &\frac{1}{4} \frac{\partial V_0^T}{\partial x} B B^T \frac{\partial V_0}{\partial x} - \frac{\partial V_0^T}{\partial x} A x - \frac{\partial V_0}{\partial t} = x^T Q x \\ \epsilon^1 : \quad &\frac{1}{4} \frac{\partial V_1^T}{\partial x} B B^T \frac{\partial V_0}{\partial x} + \frac{1}{4} \frac{\partial V_0^T}{\partial x} B B^T \frac{\partial V_1}{\partial x} - \frac{\partial V_1^T}{\partial x} A x - \\ &\frac{\partial V_1}{\partial t} = N_0(V_0; x) \end{aligned} \quad (25)$$

$$\begin{aligned} \epsilon^2 : \quad &\frac{1}{4} \frac{\partial V_2^T}{\partial x} B B^T \frac{\partial V_0}{\partial x} + \frac{1}{4} \frac{\partial V_0^T}{\partial x} B B^T \frac{\partial V_2}{\partial x} + \frac{1}{4} \frac{\partial V_1^T}{\partial x} B B^T \frac{\partial V_1}{\partial x} \\ &- \frac{\partial V_2^T}{\partial x} A x - \frac{\partial V_2}{\partial t} = N_1(V_0, V_1; x) \end{aligned}$$

$$\begin{aligned} \epsilon^n : \quad &\frac{1}{4} \sum_{i=0}^n \frac{\partial V_i^T}{\partial x} B B^T \frac{\partial V_i}{\partial x} - \frac{\partial V^T}{\partial x} A x - \frac{\partial V}{\partial t} = \\ &= N_{n-1}(V_0, V_1, \dots, V_{n-1}; x) \quad n = 1, 2, \dots \end{aligned}$$

(i) Observe that the first equation in (25) is a nonlinear (quadratic) first-order partial differential equation in $V_0(t)$ and has a well-known solution as given by equation (21). The other subsequent equations are linear first order partial differential equations in V_1, V_2, \dots respectively.

(ii) They are recursively connected and the n^{th} equation contains all the solutions of the previous (n-1) equations.

$$u^*(x,t) = -[\tan h(T-t)]x + 2\mu x^3(1-\cosh^{-4}(T-t)) + x^3\left[\frac{3T-3t}{4} + \frac{1}{2}\sinh(T-t) + \frac{1}{16}\sinh 4(T-t)\right]\cosh^{-4}(T-t) + \dots$$

Comments and Conclusions: A systematic perturbation method has been developed based on the Bellman Fundamental Technique of perturbation. The method can be applied to solve a class of nonlinear analytic systems whose dependent variables (solution variables) can be expanded in a regular perturbation series near the equilibrium solution. The salient feature of the method is that the auxiliary equation used in the technique is nonlinear. Thus the central point of success of the method lies in choosing a suitable auxiliary equation (whose solution is known) which should be as close in form to the nonlinear problem to be solved as possible.

References

1. IEEE Trans. on Automatic Control, Vol. 19, No. 6, December 1974.
2. Athans, M. and Falb, P., Optimal Control, New York, McGraw-Hill, 1966.
3. Anderson, B.D.O and Moore, J.B., Linear Optimal Control, Prentice Hall, New Jersey, 1971.
4. Moylan, P.J. and Anderson, B.D.O, "Nonlinear Regulator Theory and an Inverse Optimal Control Problem", IEEE Trans. on Automatic Control, Vol. 18, No. 5, Oct. 1973, pp. 460-465.
5. Bellman, R. and Bucy R., "Asymptotic Control Theory", SIAM J. Control, Vol. 2, No. 1, 1964, pp. 11-18.
6. Al'brekhat, E.G., "Optimal Stabilization of Nonlinear Systems", J. Appl. Math. of Mich. (25), 1961, pp. 1254-1266.
7. Kalman, R.E., "Contributions to the Theory of Optimal Control", Bol. Soc. Motem, Mex. 1960, pp. 102-109.
8. Dauer, J.P., "Nonlinear Perturbations of Quasilinear Control Systems", J. Math. Anal. & Appl., 54, pp. 717-725 (1976).
9. Courant, R. and Hilbert, D., Methods of Mathematical Physics Vol. II, Wiley-Interscience, New York, 1962.
10. Bellman, R., Perturbation Techniques in Mathematics, Physics and Engineering, Holt, Rinehart & Winston, New York, 1964.
11. Volterra, V., Theory of Functionals and Integral and Integrodifferential Equations, Dover Publications, 1959.
12. Garrard, W.L., McClamroch, N.H., and Clark, L.G., "An Approach to Sub-Optimal Feedback Control of Nonlinear Systems", Int. J. Control, Vol. 10, No. 6, pp. 657-663 (1969).
13. Garrard, W.L., "Sub Optimal Feedback Control for Nonlinear Systems", Automatica, Vol. 8, pp. 219-221, 1972.

14. Baldwin, J.F. and Sim Williams, J.H., "The Use of a Method of Perturbation in the Synthesis of Closed-Loop Optimal Control Laws for Nonlinear Systems", Automatica (5), pp. 357-367 (1969).
15. Nishikawa, N., Sannomiya, N., and Itakwa, H., "A Method for Sub-Optimal Design of Nonlinear Feedback Systems", Automatica, Vol. 7, pp. 703-712, 1971.
16. Lukes, D.L., "Optimal Regulations of Nonlinear Dynamical Systems", SIAM J. Control, Vol. 7, No. 1, pp. 75-100, February 1969.
17. Brockett, R.W., Finite Dimensional Linear Systems, John Wiley (1970).
18. Trèves, Francis, Basic Linear Partial Differential Equations, Academic Press (1975).

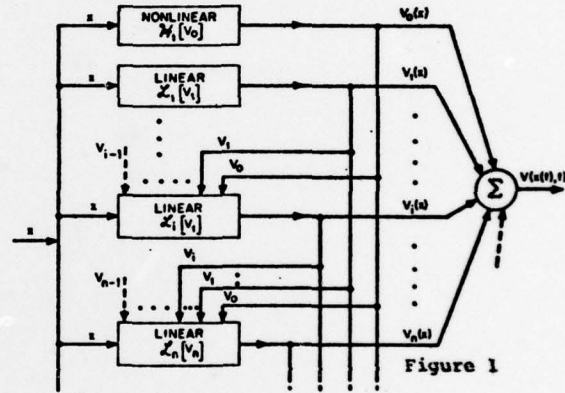

Figure 2

