

AD-A062 796

MASSACHUSETTS INST OF TECH CAMBRIDGE LAB FOR INFORMATICS F/G 12/1  
FINITE-STATE CONTROL OF UNCERTAIN SYSTEMS. (U)  
SEP 78 S N JONES

AFOSR-77-3281

UNCLASSIFIED

LIDS-TH-853

AFOSR-TR-78-1515

NL

1 OF 2

AD A062796



A microfiche card containing a grid of 132 frames (10 rows by 14 columns). The frames contain various technical content, including text, diagrams, and mathematical equations. The text is too small to read clearly, but some frames contain mathematical symbols like  $\Delta$ ,  $\Gamma$ , and  $\Sigma$ . Some frames also contain small diagrams or flowcharts.

OF 2

0627

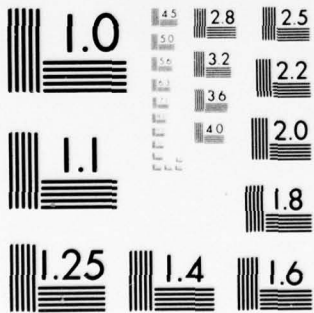

MICROCOPY RESOLUTION TEST CHART  
NATIONAL BUREAU OF STANDARDS 1963-A

AD A062796

AFOSR-TR- 78 - 15 1 5

September, 1978

LIDS-TH-853

Research Supported By:

AFOSR Grant 77-3281

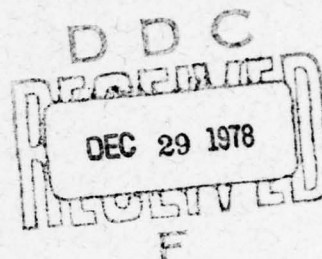
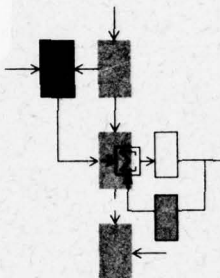

## FINITE-STATE CONTROL OF UNCERTAIN SYSTEMS

Steven Norman Jones

AIR FORCE OFFICE OF SCIENTIFIC RESEARCH (AFSC)  
NOTICE OF TRANSMITTAL TO DDC  
This technical report has been reviewed and is  
approved for public release under E.O. 11652 (7b).  
Distribution is unlimited.  
A. D. BLOSE  
Technical Information Officer

Laboratory for Information and Decision Systems

Formerly

Electronic Systems Laboratory

MASSACHUSETTS INSTITUTE OF TECHNOLOGY, CAMBRIDGE, MASSACHUSETTS 02139

78

12 21 04

Approved for public release;  
distribution unlimited.

REPORT DOCUMENTATION PAGE		READ INSTRUCTIONS BEFORE COMPLETING FORM
1. REPORT NUMBER <b>AFOSR-TR- 78-1515</b>	2. GOVT ACCESSION NO.	3. RECIPIENT'S CATALOG NUMBER
4. TITLE (and Subtitle)  FINITE-STATE CONTROL OF UNCERTAIN SYSTEMS		5. TYPE OF REPORT & PERIOD COVERED  Interim
		6. PERFORMING ORG. REPORT NUMBER
7. AUTHOR(s)  Steven Norman Jones		8. CONTRACT OR GRANT NUMBER(s)  AFOSR 77-3281
9. PERFORMING ORGANIZATION NAME AND ADDRESS  Massachusetts Institute of Technology Lab. for Information & Decision Systems Cambridge, MA 02139		10. PROGRAM ELEMENT, PROJECT, TASK AREA & WORK UNIT NUMBERS  61102F 2304/A1
11. CONTROLLING OFFICE NAME AND ADDRESS  Air Force Office of Scientific Research/NM Bolling AFB, Washington, DC 20332		12. REPORT DATE September 1978
		13. NUMBER OF PAGES 123
14. MONITORING AGENCY NAME & ADDRESS (if different from Controlling Office)		15. SECURITY CLASS. (of this report)  UNCLASSIFIED
		15a. DECLASSIFICATION/DOWNGRADING SCHEDULE
16. DISTRIBUTION STATEMENT (of this Report)  Approved for public release; distribution unlimited.		
17. DISTRIBUTION STATEMENT (of the abstract entered in Block 20, if different from Report)		
18. SUPPLEMENTARY NOTES		
19. KEY WORDS (Continue on reverse side if necessary and identify by block number)		
20. ABSTRACT (Continue on reverse side if necessary and identify by block number)  An ambiguous process is defined as a closed, convex set of stochastic processes which fulfills certain properties. In the context of computer control, ambiguous processes can be used as simplified models for the complex interaction of a non-linear computer controller and continuous plant with uncertain dynamics. Using this simplified model, and applying results on worst-case optimality in ambiguous processes, the feedback system can be better understood and definite performance bounds can be calculated.		

September 1978

LIDS-TH-853

FINITE-STATE CONTROL OF UNCERTAIN SYSTEMS

by

Steven Norman Jones

This report is based on the unaltered thesis of Steven Norman Jones, submitted in partial fulfillment of the requirements for the degree of Master of Science at the Massachusetts Institute of Technology, September 1978. The research was conducted at the M.I.T. Electronic Systems Laboratory, with support provided in part by AFOSR Grant 77-3281.

Laboratory for Information and Decision Systems  
Formerly  
Electronic Systems Laboratory  
Massachusetts Institute of Technology  
Cambridge, Massachusetts 02139

FINITE-STATE CONTROL OF UNCERTAIN SYSTEMS

by

Steven Norman Jones

B.S., Massachusetts Institute of Technology  
(1977)

SUBMITTED IN PARTIAL FULFILLMENT  
OF THE REQUIREMENTS FOR THE  
DEGREE OF

MASTER OF SCIENCE

at the

MASSACHUSETTS INSTITUTE OF TECHNOLOGY

August, 1978

© Steven Norman Jones 1978

Signature of Author.....*Steven Jones*.....  
Department of Electrical Engineering and Computer Science  
August 31, 1978

Certified by.....*Timothy L. Heron*.....  
Thesis Supervisor

Accepted by.....  
Chairman, Department Committee

FINITE-STATE CONTROL OF UNCERTAIN SYSTEMS

by

Steven Norman Jones

Submitted to the Department of Electrical  
Engineering and Computer Science on August 31, 1978  
in partial fulfillment of the requirements for the  
Degree of Master of Science.

ABSTRACT

An ambiguous process is defined as a closed, convex set of stochastic processes which fulfills certain properties. In the context of computer control, ambiguous processes can be used as simplified models for the complex interaction of a nonlinear computer controller and continuous plant with uncertain dynamics. Using this simplified model, and applying results on worst-case optimality in ambiguous processes, the feedback system can be better understood and definite performance bounds can be calculated.

Thesis Supervisor: Timothy L. Johnson, Associate Professor  
of Electrical Engineering and Computer  
Science, MIT.

#### ACKNOWLEDGMENT

I am indebted to Professor Timothy Johnson for his patience and support over the many months of research culminating in this thesis. I would also like to thank Pierre Humblet for his valuable help on the stochastic aspects of the problem.

This research was conducted in the Decision and Control Sciences Group of the MIT Electronics Systems Laboratory, and was supported by the Air Force Office of Scientific Research under Grant number AFOSR77-3281.

## TABLE OF CONTENTS

	PAGE
ABSTRACT	2
ACKNOWLEDGEMENTS	3
CHAPTER I INTRODUCTION AND OVERVIEW	
1.1 Finite-State Control	6
1.2 Generality of the Finite-State Model	10
1.3 Summary of Past Work	13
1.4 Conclusions of Thesis	14
1.5 Overview of Methods and Results - Bounding Performance	15
CHAPTER II FINITE-STATE COMPENSATION AND AMBIGUOUS PROCESSES - THEORY	
2.1 Introduction	27
2.2 Ambiguous Measure Spaces	27
2.3 Definition of Closed-Loop System	36
2.4 Measures of Performance	40
2.5 Example: Tracking and Regulation	42
2.6 Defining an Ambiguous Process for a Compensated System	44
2.7 Bounds on Performance	68
2.8 Ambiguous Processes	70
2.9 Markov Processes	72
2.10 Differential Properties of Markov Processes	76
2.11 Maximization of $J$ in $\mathcal{C}$	80
2.12 Fundamental Bounding Theorem	82

	PAGE
CHAPTER III	
3.1 Balancing an Inverted Pendulum	90
3.2 The Noisy Inverted Pendulum	106
3.3 Simplex Measure Sets	114
3.4 Topics for Future Research	120
REFERENCES	122

## INTRODUCTION AND OVERVIEW

## 1.1 Finite-State Control

The development of compact, high-speed and inexpensive computers over the past several decades has greatly expanded the range of applications of automatic controls (into consumer electronics and medical instruments, for example) and has made possible a vast range of machinery that would otherwise be beyond human control, such as rockets, aircraft, and complex factory and plant processes. Concurrent with the development of the necessary hardware, there has been increasing understanding of the interaction between control devices and systems, i.e., of feedback control, and many principles of optimality for control systems. These capture many aspects of real-world control problems, but do not take into account the actual electronic gadgetry that is used to implement the controller systems. In some cases, computers have sufficient speed and precision that the differences between the dynamics of the actual implementation and the mathematical model used to design it are negligible. But when we push the limits of computation speed and accuracy, it becomes necessary to understand the differences in performance, and at present there is little theoretical insight on this problem.

Nevertheless, the very fact that computers are capable of high speed and precision points out an obvious issue:

could computers (and, in general, the interfaces used between them and the continuous system being regulated) be used more efficiently if their capabilities were accounted for theoretically? Specifically, could we get by with less equipment and speed than we are now using? The use of "optimal" control theories as a basis for practical design may result in a complicated, expensive, or costly design which must be simplified if it is to be implemented. Engineers are definitely in need of some insight into the interaction of computer and real-world systems both for bounding their performance and designing cost-effective control solutions, and predicting performance during the design phase.

Consider the following example. Suppose we wish to balance an inverted pendulum using state feedback from the pendulum angle and angular velocity. Torques up to a certain maximum can be applied to the pendulum for control. Modern control design theory would first linearize the pendulum dynamics about zero and find the optimal linear state feedback map  $u(t) = Kx(t) = k_1\theta(t) + k_2\dot{\theta}(t)$ . This would then be implemented by digitizing  $\theta(t)$  with an A/D converter to, say, eight bits; calculating  $\dot{\theta}(t)$  and  $u(t)$  in a microprocessor, making sure the resulting control does not exceed the maximum, and converting the resulting control level back to analog with a DAC.

For the application at hand, though, it might be entirely

satisfactory to use a controller of the following kind: When the pendulum velocity exceeds a certain amount  $\dot{\theta}_{\max}$ , controls are applied to reduce the predicted velocity to nearly zero. When the pendulum angle exceeds a certain amount  $\theta_{\max}$ , again a control is applied to put the predicted angle near zero. Should both occur simultaneously, we first reduce the velocity, then the angle.

This control law calls for a compensator with two sequences of states, probably both short, which apply the proper control patterns. The only input this compensator needs is one of three levels on two input channels (i.e.,  $-\infty$  to  $-\theta_{\max}$ ,  $-\theta_{\max}$  to  $\theta_{\max}$ ,  $\theta_{\max}$  to  $\infty$  on the  $\theta$  channel). It could be very easily implemented, and should more smoothness in the control be desired, the control sequences could be extended as necessary.

The major problem with this design is the analysis - to set certain criteria for its performance. and see if it fulfills them. Later we will apply rigorous analysis to this example and actually design and bound the performance of a six-state compensator.

This thesis is concerned with bounding the performance of computer-based control systems. We will study computer-based control in its own right, letting the actual limitations of the computer dictate the direction of the theory, as well as the actual

structure of the implementation. To this end we start with a very general model of a computer-based controller, not only for analytical simplicity, but also to free us of artificially imposed constraints of present-day computer architecture. Specifically, our results suggest that the add-divide-multiply analysis of modern digital control is not essentially necessary, and that the high-precision data acquisition A/D converters may not be as necessary as they are assumed to be.

Consider this very general model of a computer controller: at any time in a discrete time set  $T = 0, 1, \dots$ , the computer receives an observation of the system state. The resolution of this observation is limited by a coder (see Fig. 1) which can only distinguish between a finite number of possibilities. Thus the observation will be one of a finite set  $Y$ . Of course this model of a coder is consistent with present day A/D converters, but is much more general.

Next we assume that the computer is a finite-state machine (refer to Minsky [1]) which receives inputs from the coder and changes states according to the coder observation. Letting  $Z$  be the finite state set, there is a mapping  $\tau$  which determines the controller state at  $T+1$  according to the state at  $T$  and the coder observation  $y \in Y$  at  $T$ :

$$z(T+1) = \tau(z(T), y(T)) \quad .$$

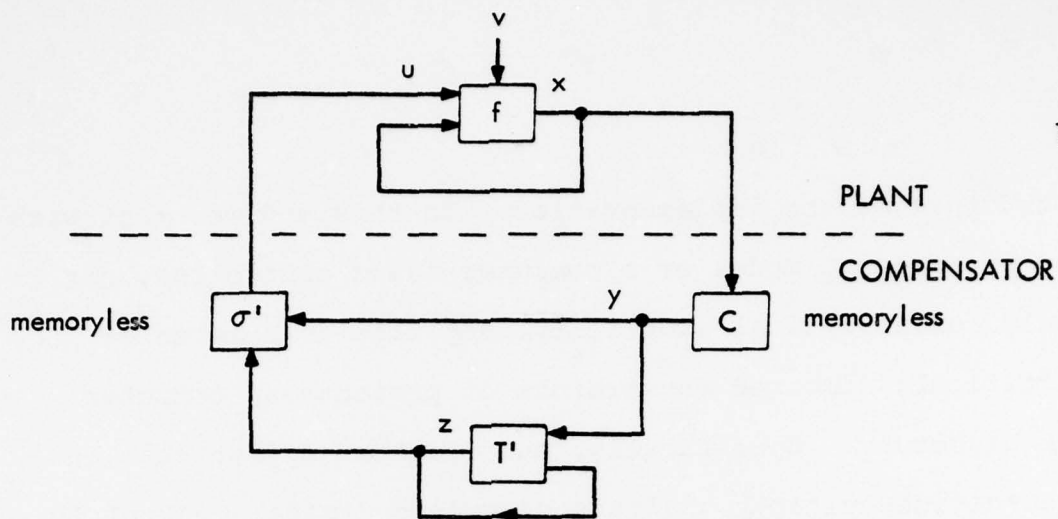

Figure 1.

Finally we assume that the controller's output to the plant at time  $T$  is a function of the coder observation at time  $T$  and the controller state at time  $T$ . Letting  $u(T)$  represent the control signal,

$$u(T) = \sigma(z(T), y(T)) \quad .$$

This is our complete model of a computer compensator. Any compensator of this kind will always be referred to as a finite state compensator or finite state controller.

Sometimes it is unrealistic to assume no delay between the coder observation and the determination of the control, as the last equation suggests. But by suitably expanding the state space, and then removing the direct dependence of the control signal on the coder observation, any delays introduced by the coder can be taken into account.

## 1.2 Generality of the Finite-State Model

The compensator described in the last section is not named the "finite input, output, state" compensator because any compensator with only a finite number of states must have

this structure (under only one other assumption which is reasonable for digital processing equipment).

Any deterministic compensator with state set  $Z$  and output set  $U$  must be describable by two equations

$$z(T+1) = \tau(x(T), x(T)) \quad (1)$$

$$u = \sigma(z(T), x(T)) \quad T = 0, 1, \dots$$

where  $z(T) \in Z$ ,  $u(T) \in U$ , and  $x(T) \in X$  is the state of the plant, or system to be controlled, at time  $T$ . Look at the map:

$$\tau: Z \times X \rightarrow Z.$$

Since  $Z$  is finite there must be a finite number of  $\tau$ -equivalent regions of  $X$  defined by

$$R_{z_1 z_2} = \tau^{-1}(z_{q_1}(z_{q_2})) ; \text{ i.e. } \tau(z_{q_1}, x) = z_{q_2} \text{ iff } x \in R_{z_1 z_2} .$$

Since the number of regions is finite and

$$\bigcup_{\substack{z_1 \in Z \\ z_2 \in Z}} R_{z_1 z_2} = X$$

there must be a minimal finite decomposition of  $X$  into disjoint regions  $\{R_i\}$ ,  $i = 1, \dots, r$  such that each  $R_{z_1 z_2}$  is contained in precisely one  $R_i$ . Define the map

$$C: X \rightarrow Y \quad Y = \{1, \dots, r\}$$

so that  $C$  takes  $x \in X$  to the index of the region  $R_i$  to which  $x$  belongs. Call  $C$  the coder associated with the compensator, since

$$z(T+1) = \tau'(z(T), C(x(T)))$$

for some  $\tau'$ .

We have to make one additional assumption about the compensator: that there exists a  $\sigma'$  such that

$$u(T) = \sigma'(x(T), C(x(T))) \quad .$$

This assumption is realistic for digital compensators where there is no direct analog feedthrough from the input to the output, so we see that  $\tau'$  and  $\sigma'$  and  $Y$  satisfy precisely the requirements set down for a finite compensator as in Section 1.1.

### 1.3 Summary of Past Work

Research into finite-state control has been somewhat scanty because of the difficulty in finding a model which is both theoretically tractable and still applicable to present problems. Perhaps the most successful theory relevant to finite-state control systems is the linear discrete-time system theory (Freeman [2]) especially when applied to linear algebraic structures such as rings (Kalman, Falb, Arbib [3], Padulo, Arbib [4], and more specifically directed toward control is Davis [5]). Rings over the integers or finite rings most closely capture the finiteness of the compensator. Unfortunately, these theories are not useful unless a similar algebraic structure is assumed for the plant, which may be unrealistic. Some attempts have been made at hybrid models, (discussed generally in Kalman, Falb, Arbib [6] and Johnson [7]).

Finite-state control is found in the optimal solution of the general minimum-time problem in classical control (Athans and Falb [8]). The optimal control the "bang bang" controllers, is a finite-state controller in the sense defined in Section 1.1, however the coder is highly nonlinear and in general, very difficult to implement. (In the examples of finite-state controller cited in this thesis, the coder will always divide the state-space into linear regions, thus simplifying implementation.) The maximum principle has

been extended to finite-state systems by Sandell [9].

In this thesis we will also be considering types of uncertainty that are not probabilistic. Much past work has been done in devising alternatives to probability; perhaps most widely known is "fuzzy set" theory (Zadeh [10]). Our work is most closely related to the "unknown but bounded" concept discussed in Schweppe [11].

#### 1.4 Conclusions of Thesis

In this short work we have not been able to explore the approach in any depth and so we can only draw conclusions based on preliminary theoretical results and examples. The major areas of actual results are:

- 1) A method by which complex, nonlinear, uncertain systems can be simplified to finite state models called "ambiguous processes". This method is developed specifically for feedback systems composed of finite-state compensators and nonlinear plants.

- 2) Properties of ambiguous systems and optimality conditions from which performance bounds can be obtained.

- 3) Some suggestions for designing an algorithm which could automatically calculate performance bounds for a finite-state control system.

The qualitative conclusions of this thesis which we have tried to support with mathematical justification are:

1. Finite-state compensation is sufficiently complex that the most useful and general theories will study bounds on performance rather than exact performance. We have taken this approach in our work and shown that methods of attack which are not guaranteed to deliver exact measures but may guarantee worst case performance bounds can give significant insight into a finite-state feedback system.

2. Through examples we will show that simple finite-state machines with only a few inputs, outputs and states can compensate a system, which under present theories would require a more complex design. Furthermore we will show how to calculate a lower bound on the performance of such a compensator.

3. We also conclude that some ideas from artificial intelligence can be made rigorous and applied to problems in finite-state compensation. This will become apparent in the sequel as we introduce knowledge spaces, conceptual states and discussion of optimizing control given a particular conceptualization of the problem.

#### 1.5 Overview of Methods and Results - Bounding Performance

To illustrate the methods and results formalized in subsequent sections, we will show their application to simple examples. The discussion here will be informal and intuitive, so the reader can more easily understand the motivation for the formal mathematical definitions to be

given later.

Consider first the problem of bounding the performance of a given compensator. We assume the plant is defined in terms of a finite-dimensional Euclidean state space  $X = R^n$ ; state transition function  $f$ , which takes the discrete-time state  $x(T) \in R^n$ , control  $u(T) \in R^m$ , and noise value  $v(T) \in R^p$ , to the next state

$$x(T+1) = f(x(T), u(T), v(T)) \quad ;$$

and sets of possible probability measures for the initial state and for the noise occurrences  $v(T)$ ; these sets could contain for example, only a single probability measure, corresponding to a stochastic system. Regardless of whether the measure sets for  $x(0)$  or  $v(T)$  contain more than one probability measure, our analysis will necessarily lead to measure sets with more than one, so it is convenient to make the more general assumption from the beginning. For practical calculations we will introduce the simplicial measure sets in Chapter 3 which are finitely describable and simplify calculations. However, since the formal development is somewhat involved, Chapter 2 will proceed to develop the major ideas assuming only the minimal necessary properties of the measure sets for  $x(0)$  and  $u(T)$ . A system of measure sets with these properties will be dubbed an "ambiguous measure space". Simplicial measure sets cannot describe an arbitrary simple probability measure, so in practical examples, if the model

of the plant includes a probabilistic noise model, then the probability distribution of  $x(0)$  and  $v(T)$  will have to be enclosed in a simplicial measure set. Since the true distribution is somewhere in this set, the true performance must be within the bounds calculated, but better bounds would of course be obtainable if the actual probability were known.

There are however, some additional advantages to the simplicial measure set model. First, some kinds of knowledge about the plant or the noise can be best captured by a set of probability measures. For instance, knowing  $0 \leq x \leq 2$  could be restated that the possible probability measures for  $x$  must have all mass in the interval  $[0,2]$ . This gives a possible set of measures, rather than a single measure, to represent the knowledge about  $x$ , and indeed this set is a simplicial measure set. This idea of representing noise only by a set of possible values, or the unknown but bounded noise model, has been formulated elsewhere (Schweppe [11]) but has not been developed too far in control.

Second, there are special cases where the optimal finite-state compensator, given only a simplicial measure set as a priori information, may indeed be optimal over all compensators. This relies on a property called finite information lifetime.

Whatever the noise model chosen, probabilistic, simplex measure set, etc., the dynamics of any computer feedback

control are complex and difficult to analyze due to the thresholding effects of the coder, and finite memory of the computer. To simplify the feedback system sufficiently for analysis, we model it as an ambiguous process, from which definite bounds on the performance, although not the exact performance can be obtained. An ambiguous process is a set of non-stationary Markov process whose transition probabilities are known to lie within some range; the ambiguity arises from simplifying the dynamics of the system to a finite-state model. To make these ideas more concrete, consider the following first order system:

$$x(T+1) = \frac{3}{2} x(T) + u(T) + v(T) .$$

Let  $x(0)$  be a random variable with all mass between  $-1$  and  $1$ , and let  $v(T)$  be a random variable with mass  $.1$  in  $(-\frac{1}{2}, -\frac{1}{4})$ ,  $.4$  in  $(-\frac{1}{4}, 0)$ ,  $.4$  in  $(0, \frac{1}{4})$ , and mass  $.1$  in  $(\frac{1}{4}, \frac{1}{2})$ , for all  $T$ . We take open intervals to avoid intersecting sets resulting in a single point. We represent the a priori knowledge of  $x(0)$  and  $v(T)$ , then by the diagrams in Figure 2.

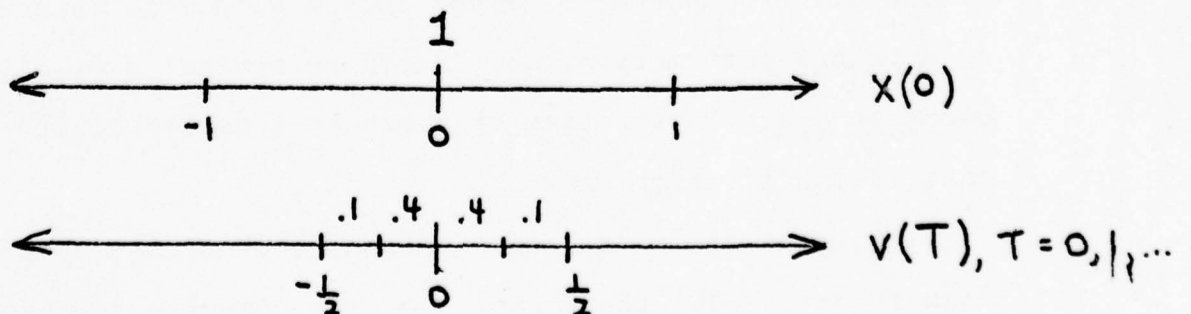

Figure 2.

It has been suggested to control this unstable system with a single-state compensator with  $Z = \{z\}$ ,  $U = R$ ,

$$y = C(x) = \begin{cases} 1 & -3 \leq x \leq -1 \\ 2 & -1 \leq x \leq 1 \\ 3 & 1 \leq x \leq 3 \\ 0 & \text{if } |x| > 3 \end{cases}$$

$$\tau(z, y) = z \quad \forall y,$$

$$\sigma(z, y) = \begin{cases} +2 & y = 1 \\ 0 & y = 2 \\ -2 & y = 3 \\ 0 & y = 0 \end{cases}$$

The coder value of zero represents failure of the system, i.e., if the system state ever exceeds 3 or -3, we are no longer interested in the behavior. Diagrammatically we represent the compensator in Figure 3.



Figure 3.

Finally take as a performance criterion of this system

$$J = \liminf_T \frac{1}{T} \sum_{n=0}^{\infty} -[x(T)]^2$$

$$J = -\infty \text{ if } |x(T)| > 3 \text{ for any } T = 0, \dots$$



where  $\{u\}$  is the set of all possible measures for  $v(T)$ . Examining the diagram we see that for  $\delta_{\frac{3}{2}}$  the probability of going from  $A_2$  to  $A_1$  can be as high as 1. By symmetry we see that the probability of going from  $A_2$  to  $A_3$  can also be 1. By taking  $x(T) \sim \delta_0$ , we see that the probability of staying in  $A_2$  could be as high as 1. We therefore conclude that the transition probabilities to  $A_0, A_1, A_2, A_3$  starting from  $A_2$  is a vector (we differ here from the standard notation)

$$p_{2x} = \begin{pmatrix} p_{20} \\ p_{21} \\ p_{22} \\ p_{23} \end{pmatrix} \quad \text{where} \quad \begin{array}{l} p_{20} \in [0] \\ p_{21} \in [0,1] \\ p_{22} \in [0,1] \\ p_{23} \in [0,1] \end{array}$$

and  $(1,1,\dots,1)p_{2x} = 1$ . For convenience we write this as

$$p_{2x} \in \begin{pmatrix} [0] \\ [0,1] \\ [0,1] \\ [0,1] \end{pmatrix}$$

with the understanding that  $p_{2x}$  is a probability vector so only choices with  $(1,1,\dots,1)p_{2x}$  are valid. The reader can check that

$$P_{1 \times \epsilon} = \begin{pmatrix} [0] \\ [0,1] \\ [0,1] \\ [0] \end{pmatrix} \quad P_{3 \times} = \begin{pmatrix} [0] \\ [0] \\ [0,1] \\ [0,1] \end{pmatrix}$$

We now arrange the vector into a matrix which represents the transition matrices possible:

$$P' = \begin{pmatrix} [0] & [0] & [0] \\ [0,1] & [0,1] & [0] \\ [0,1] & [0,1] & [0,1] \\ [0] & [0,1] & [0,1] \end{pmatrix}$$

Seeing that the top row must be zero, the closed-loop system can therefore never fail so long as  $x(0)$  is in  $A_1$ ,  $A_2$  or  $A_3$ . Thus  $J > -\infty$  and we concern ourselves with the matrix

$$P = \begin{pmatrix} [0,1] & [0,1] & [0] \\ [0,1] & [0,1] & [0,1] \\ [0] & [0,1] & [0,1] \end{pmatrix}$$

which we take as defining an ambiguous process, and it is possible for this somewhat trivial model, that the closed loop state could remain in  $A_1$  and  $A_3$  forever, and if  $(x z) \in A_1$  or  $A_3$ ,  $x$  can be as large as 3, so  $J$  could be as small as -9, since

$$J = \liminf_{T \rightarrow \infty} \frac{1}{T} \sum_{n=1}^T -x^2 \geq \liminf_{T \rightarrow \infty} \frac{1}{T} \sum_{n=1}^T -9 = -9$$

This is not a very good bound so we will try a more detailed conceptualization. Denote the knowledge that  $x(T) \in A_2$  by 2 ; this will be called a generalized state. In our previous conceptualization the closed-loop system was represented by

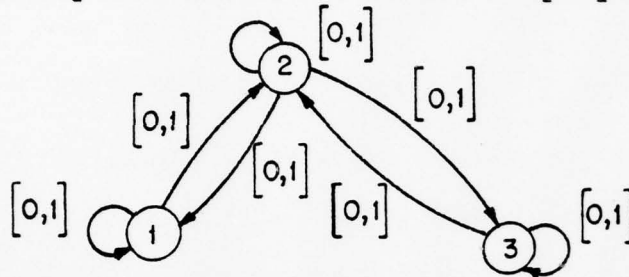

Now let  $\textcircled{21}$  denote the generalized state of the closed-loop system of  $T$  if  $x(T-1) \in A_2$  and  $x(T) \in A_1$ . We expand our conceptualization to:

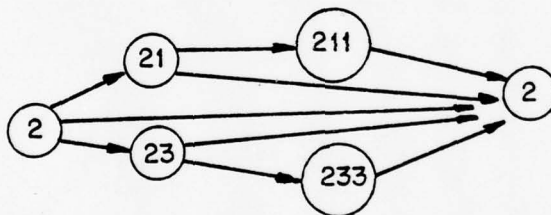

where we have duplicated the  $\textcircled{2}$  on the right side for graphical purposes, and the arrows represent the possible transitions that can occur. We now place bounds on the probability of each possible transition.

The transition from  $\textcircled{2}$  can be arbitrary as we have previously seen. However, the probabilities of the various transition leaving  $\textcircled{21}$  are different from the ones calculated previously for the more general conceptual state  $\textcircled{1}$ , since we have, in addition to the information that  $x(t) \in A_1$ , the information that  $x(T-1) \in A_2$ . Thus we can limit the

uncertainty of  $x(t)$  and limit the range of possible transition probabilities.

To see this, notice that all of the mass of any measure of  $x$ , given  $21$ , must lie in  $[-2, -1]$ , so that  $\frac{3}{2}x(T+1) + u(T)$  must lie in  $[-1, \frac{1}{2}]$ , and  $\frac{3}{2}x(T+1) + u(T) + v(T)$  must have all mass in  $[-\frac{3}{2}, 1]$ . But notice that the greatest probability that  $x(T+1) \in A_1$  is .5 and occurs when  $\frac{3}{2}x(T+1) + u(T) \sim \delta_{-1}$ . The smallest probability for this transition is 0. If in fact  $x(T+1) \in A_1$  then our knowledge about  $x(T+1)$  is  $211$ , and  $x(T+1)$  must lie in  $[-\frac{3}{2}, -1]$ , so  $x(T+2)$  will surely lie in  $A_2$ . Using this information we can label each transition with its set of possible probabilities:

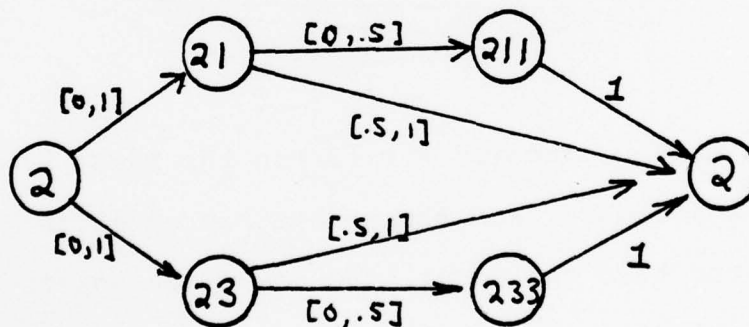

We now ask what is the minimum  $J$  possible given this range of transition probabilities at each step, and also knowing that  $x(0) \in A_2$ . Intuitively we see that the lowest possible return will occur by taking the probability to  $211$  and  $233$  as high as possible, so to obtain a lower bound on  $J$  we calculate the limiting ergodic state probabilities of the worst case:

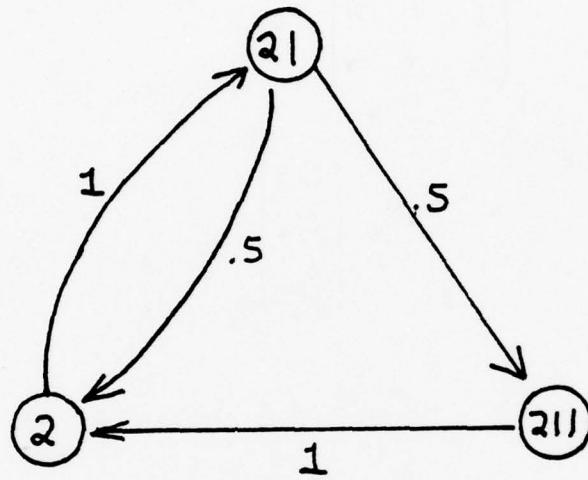

The limiting state probabilities  $p$  must satisfy:

$$\begin{pmatrix} 0 & .5 & 1 \\ 1 & 0 & 0 \\ 0 & .5 & 0 \end{pmatrix} p_{\infty} = p_{\infty}$$

so

$$p_{\infty} = \begin{pmatrix} 2/5 \\ 2/5 \\ 1/5 \end{pmatrix}$$

and

$$J = \liminf_{T \rightarrow \infty} \frac{1}{T} \sum_{n=1}^T -x^2 \geq \frac{2}{5} (-1) + \frac{2}{5} (-9) + \frac{1}{5} (-9) = -\frac{29}{5}$$

which is a considerably improved bound.

The two conceptualizations of the feedback system described above gave rise to two ambiguous processes. One of the major results of this thesis is to prove that a lower bound on the performance of an ambiguous process is the result of some choice of the transition probabilities at their extreme points, and that this is a valid lower bound even if the real transition probabilities change at each step.

By increasing the number of generalized states, better and better bounds can be obtained. Unfortunately we have not been able to prove that these bounds must approach the true performance, although it seems very likely. We have though, formalized these ideas and found a number of optimality conditions which could lead to a bounding algorithm.

## CHAPTER II

FINITE-STATE COMPENSATION AND AMBIGUOUS  
PROCESSES-THEORY

2.1 Most of the ideas that were discussed informally in the Introduction and Overview will be nailed down precisely in this Chapter. Conceptually, the material divides into two parts. In the first part, encompassing Sections 2.2 through 2.7, a precise model of a feedback control system involving a finite-state compensator and continuous plant is defined section by section, and it is shown that any such feedback system can be simplified to a finite-state model called an ambiguous process. The name arises because the transition probabilities for the simplified finite-state model may not be well-defined.

The second part, Sections 2.8 through 2.12, develops an abstract theory of ambiguous processes, without making reference to their application in finite-state control. Optimality conditions are derived and a fundamental bounding theorem is proved. This theory will form the basis for actual methods of bounding the performance of compensators, which will be taken up in Chapter 3.

## 2.2 Ambiguous Measure Spaces

In formulating a model of a compensated plant it is reasonable to expect some uncertainty in the behavior, even

if the control inputs are precisely known. This uncertainty can be modeled probabilistically, but for our purposes later on it is convenient to model uncertainty in a more general way, which includes probability as a special case. In fact, even if the problem is formulated probabilistically, this more general notion of uncertainty arises naturally in our analysis. To see how this comes about, we outline briefly the major steps in reducing a compensated system to an ambiguous process.

Suppose that a compensated system is running, and we, as an outside observer, make observations of the progress of plant state  $x(T)$  and the compensator state  $z(T)$ . The compensator state is always an element of the finite set  $Z$  (as defined in Section 1.2) so we will assume that the compensator state is always observed perfectly. On the other hand, the plant state,  $x(T)$ , lies in Euclidean space, and we will assume that only finite information about  $x(T)$  is observed; i.e., there is a finite number of "areas" of the plant state space, and only the area of  $x(T)$  is observed. Just knowing that  $x(T)$  lies in some area does not imply a unique probability measure for  $x(T)$ , unless the area consists of a single point, so the knowledge that  $x(T)$  <sup>lies</sup> in some area is not probabilistic knowledge in and of itself. All that can be said is that if  $x(T)$  is measurable, all probability of that measure must lie in the observed area.

Suppose in addition to our knowledge that  $x(T)$  lies in some area  $A_1$ , which we will call an immediate area, we also know that  $x(T-1)$  lay in some immediate area  $A_2$ . Then it might be possible to rule out some potential probability measure for  $x(T)$  just knowing that  $x(T-1) \in A_2$ . Thus we need to represent certain kinds of measure sets in our analysis.

The first step in reducing a compensated system to an ambiguous process is to define these immediate areas and the knowledge associated with each. To give some hint of future notation,  $\mathcal{E}$  will represent the "know nothing" uncertainty, and it will be defined as the set of all probability measures on  $X = \mathbb{R}^n$ . To represent the knowledge that  $x(T) \in A_1$ , we need a projection operator which zeros any probability outside the known area; we will write

$$\eta_{A_1} = P_{A_1} \mathcal{E}$$

where  $\eta_{A_1}$ , is the knowledge associated with observation  $A_1$ .

After these areas have been defined, the second step is to define a set of histories - a set of recent observations which the observer is assumed to be able to remember. A history, call it  $\pi$ , might be that  $x(T-n) \in A_n$ ,  $x(T-n+1) \in A_{n-1}$ , ...,  $x(T) \in A_0$ , and that  $z(T-n) = z_n, \dots$ . Again  $z(T) = z_0$ . We can associate with each history  $\pi$  some (non-probabilistic) knowledge about  $x(T)$ ; for our knowledge about  $x(T-n)$  was, in

some sense,

$$P_{A_1} \epsilon_j$$

and then letting  $F_u$  denote the operator which takes the possible measures of  $x(T-n)$  to the possible measures of  $x(T-n+1)$  when control  $u$  was applied, we can write the possible measures of  $x(T-n+1)$  as

$$P_{A_2} F_{u_1} P_{A_1} \epsilon_j$$

and proceeding to the present time, we can write:

$$\eta_\pi = P_{A_n} F_{u_{n-1}} P_{A_{n-1}} \dots F_{u_1} P_{A_1} \epsilon_j .$$

We must be somewhat vague here because the development of these concepts rigorously will be a lengthy process. Suffice it to say that corresponding to each history is a set of possible probability measures on  $x(T)$ .

The third step in defining an ambiguous process will be to recognize that the observed histories form a sequence in time, call it  $\pi(0), \pi(1), \dots$ . A journal will be defined as an automaton whose state space is the set of possible histories, and which makes transitions from one history to the next depending on each observation. It is clear that there is a "best" journal for each set of histories, namely the journal that carries the greatest amount of information from past histories into future histories, within the

limitations of its finite state space.

The last step is recognizing that the journal is an "ambiguous process", in the following sense. The probability of making each observation  $A_i$  at some time  $T+1$ , (which determines the probability of going to each new journal state,  $\pi(T+1)$ ) depends on the probability measure of  $x(T)$ . Associated with the present journal state  $\pi(T)$  is some knowledge about  $x(T)$ , as we described in the third step. Hence there is some "ambiguous" probability for each transition to the next journal state, based on the knowledge of  $x(T)$  that can be derived from  $\pi(T)$ .

The development of the above ideas on a rigorous basis is a task that lays before us in the next several sections. It is clear that a generalized notion of uncertainty is pervasive in the analysis. Therefore we begin in this section by defining the concept of an ambiguous measure space.

Definition: A probability measure  $\mu$  over  $R^n$  is a positive Borel measure with  $\mu(R^n) = 1$ .  $\mathcal{B}^n$  will always denote the Borel sets in  $R^n$ .

Note: Any measure will always be a probability measure unless otherwise stated.

Definition: An ambiguous measure space  $N$  over  $R^n$  is a collection of measure sets (of probability measures) over  $R^n$  with the following properties:

a)  $\mathcal{E}^n$  = set of all probability measures in  $\mathbb{R}^n$ , is in  $N$ .

b)  $x \in \mathbb{R}^n \rightarrow \{\delta_x\} \in N$  ( $\delta_x$  is measure with unit mass at  $x$ ).

c) A set  $S$  is representable in  $N$  iff

$$\{\mu \mid \mu(S) = 1, \mu(\bar{S}) = 0\} \in N.$$

Define for any set  $S \in \mathcal{B}^n$  and any probability measure  $\mu$  with  $\mu(S) \neq 0$  a new measure

$$P'_S(\mu)(S_1) = \frac{\mu(S_1 \cap S)}{\mu(S)} \quad \text{all } S_1 \in \mathcal{B}^n.$$

If  $\eta \in N$  is a measure set, let

$$P_S(\eta) = \{P'_S(\mu) \mid \mu(S) \neq 0, \mu \in \eta\}.$$

We require that  $P_S(\eta) \in N$  for every representable  $S, \eta \in N$ .

Ambiguous measure spaces are useful for modeling many kinds of uncertainty. Here are some examples.

Example 1. (Ordinary Probability) Let  $X = \mathbb{R}^n$  and let

$$N_1 = \{\{\mu\} \mid \mu \text{ is a probability measure on } \mathcal{B}^n\}.$$

Let  $\mathcal{G}$  be the set of nonempty Borel sets in  $\mathbb{R}^n$ . Let  $B \in \mathcal{G}$ , and define:

$$\mathcal{E}_B^n = \{\mu \mid \mu \text{ is a probability measure on } \mathcal{B}^n \text{ and } \mu(B) = 1\}$$

$$N_2 = \{\mathcal{E}_B^n \mid B \in \mathcal{G}\}.$$

$N_1$ , the set of all probability measures, is not an ambiguous measure space because properties (b) and (c) do not hold.

However,  $N = N_1 \cup N_2$  is an ambiguous measure space, and we check the necessary properties:

a)  $\mathcal{E}^n \in N$  since  $\mathbb{R}^n$  is a Borel set and  $\mathcal{E}^n = \mathcal{E}_{\mathbb{R}^n}^n$ .

b)  $\{\delta_x\} \in N$  for every  $x \in \mathbb{R}^n$  since  $\{x\} \in \mathcal{E}^n$  and  $\delta_x$  is a probability measure, hence  $\{\delta_x\} \in N_1, \{\delta_x\} \in N$ .

c) If  $\eta \in N$  either  $\eta \in N_1$  or  $\eta \in N_2$  (or both) consider first  $\eta \in N_1$ . Then  $\eta = \{\mu\}$  and let  $S$  be a representable set; then either  $\mu(S) = 0$  or  $\mu(S) \neq 0$ . If  $\mu(S) = 0$ , then  $P_S(\eta) = \phi \in N$ ; and since the representable sets are just the Borel sets,  $\mu(S) \neq 0$  implies  $P_S(\eta)$  is the set of the single measure defined by

$$\mu'(S') = \frac{\mu(S \cap S')}{\mu(S)}$$

which is also in  $N$ .

Now consider the case where  $\eta \in N_2$ . Since

$$P_S(\mathcal{E}_B^n) = \begin{cases} \phi & \text{if } B \cap S = \phi \\ \mathcal{E}_{B \cap S}^n & \text{otherwise} \end{cases}$$

we conclude that  $P_S(\eta) \in N$ , therefore  $P_S(\eta) \in N$  for every  $\eta \in N$ , representable  $S$ , and  $N$  is ambiguous measure space.  $\square$

Note that Example 1 is the smallest ambiguous measure space which contains all the sets of a single probability measure.

Example 2. (Trivial Ambiguous Space)  $N = \{\mathcal{E}_{\mathbb{R}^n}^n\} \cup \{\{\delta_x\} : x \in \mathbb{R}^n\}$

is the smallest ambiguous measure space. The knowledge that an unknown that is represented by an  $\eta \in \mathcal{N}$  is either "the unknown is equal to  $x$ " or "the unknown could be anything in  $\mathbb{R}^n$  with any probability measure".  $\square$

Example 3. Let  $X = \mathbb{R}$  and define  $\eta_p$ ,  $0 \leq p \leq 1$ , as

$$\eta_p = \{ \mu \mid \mu \text{ is a measure on } \mathbb{R}, \mu(-\infty, 0) = 1-p, \mu(0, \infty) = p \} .$$

The knowledge we would have about an uncertain number  $x$  given  $\eta_p$  is that there is a probability  $p$  that  $x \geq 0$ . This kind of knowledge cannot be represented by a single probability measure.

Under our definition, though,  $\{ \eta_p \mid 0 \leq p \leq 1 \}$  does not constitute an ambiguous measure space.  $\square$

Example 4. Let  $S = \mathbb{R}^n$  and let  $\mathcal{B}$  be the set of all nonempty Borel sets in  $\mathbb{R}^n$ . Let

$$\eta_B = \{ \mu \mid \mu \text{ is a measure on } \mathbb{R}^n, \mu(B) = 1 \} , B \in \mathcal{B} .$$

It can be verified that the set

$$\{ \eta_B , B \in \mathcal{B} \}$$

does satisfy all the axioms of an ambiguous measure space.

Example 5. Suppose we know that  $x \in \mathbb{R}^n$  and that  $x$  is a random variable. The distribution has a continuous density

and it is known that the median is somewhere between -1 and 1 inclusive. It is interesting that this set of possible measures on  $x$  can be reduced to the kind of description given in Example 1.

Let

$$\eta_1 = \{\mu \mid \mu(-\infty, -1] = .5, \mu[-1, \infty) = .5\}$$

$$\eta_2 = \{\mu \mid \mu(-\infty, 1] = .5, \mu[1, \infty) = .5\}$$

$$\eta_3 = \{\mu \mid \mu[-1, 1] = 1\} \quad .$$

It will be noted here without proof that the measure set of  $x$  is contained in the convex hull of  $\eta_1 \eta_2 \eta_3$ . In fact, it is dense in the convex hull. □

In the next chapter we will define the simplicial measure space, that includes all the measure sets of Examples (1) and (3), and all those on Example (2) when  $B$  is a simplex. For the moment, we proceed in a more general framework. Consider, for example, the biggest ambiguous measure space:

Definition:  $\mathcal{L}^n$  is the set of all subsets of probability measures on  $R^n$ .

Obviously  $\mathcal{L}^n$  is too general for any computational purposes, but it is useful to conceptualize for general theoretical results later on.

### 2.3 Definition of the Closed-Loop System

Having the definition of ambiguous measure space behind us, we can now formulate the problem in a generalized uncertainty model which is, as we described earlier, perfectly natural and amenable to our line of analysis, and in addition, useful and even more convenient than regular probability for some of the bounding methods discussed in Chapter 3.

The general idea is that the closed-loop system is a non-stationary Markov process on the product space  $X \times Z$ , (defined in Section 1.2) and at each time  $T$  the noise is a random variable  $v(T)$  having a distribution in some measure set  $\eta_v$ , and the state has an initial distribution in some measure set  $\eta_x$ . We do not however, know which of many possible Markov processes occurs, since we do not know which probability measure actually describes  $v(T)$  and  $x(0)$ . However, for any performance criterion, a maximum and minimum over this possible set of Markov processes can be defined.

In the next two sections we will concentrate on a precise definition of these concepts before launching into the development of ambiguous processes derived from the actual closed-loop system.

Let us review the notation introduced in Section 1.2:

$X = R^n$	plant state space
$Z$	compensator state space, $q$ elements
$X \times Z$	closed loop state space
$U \subset R^m$	admissible control set
$R^p$	admissible noise set
$f: X \times U \times R^p$	$X$ plant state transition map
$\tau': X \times Z \rightarrow Z$	compensator transition map
$\sigma: X \times Z \rightarrow U$	compensator output map
$Y$	coder equivalence classes, $r$ elements
$C: X \rightarrow Y$	canonical coder map
$\tau': Y \times Z \rightarrow Z$	canonical state transition map
$\sigma': Y \times Z \rightarrow U$	canonical compensator output map

Table 1.

(We may omit the primes on  $\tau'$  and  $\sigma'$  when clear from context.)

Now let  $N_v$  be a ambiguous measure space over  $R^p$  and let  $N_x$  be a knowledge space over  $R^n$ . Assume that the set of all possible probability measures of the noise  $v(T)$ ,  $T = 0, 1, \dots$  is a measure set  $\eta_v \in N_v$ . Similarly assume that the set of all possible probability measures of  $x(0)$  is a measure set  $\eta_0 \in N_x$ . We could have, for example, both  $\eta_v$  and  $\eta_0$  consisting of a single probability law but this is sometimes a clumsy case for actually computing bounds, as we shall see in Chapter 3. It is easier to have  $\eta_0$  and  $\eta_x$  simplex measure sets, or equivalently,  $N_x$  and  $N_v$  simplex knowledge spaces, as

described in the next Chapter.

Next assume that  $C^{-1}(y)$  is representable in  $N_x$  for all  $y \in Y$ , so that  $C^{-1}(y)$  is a Borel set and we can define the conditional probability

$$\mu[x \in C^{-1}(y)](B) = \mu[B \cap C^{-1}(y)] \quad B \in B^n$$

Our last assumption is on the smoothness of  $f$ . For any  $\lambda \in \eta_v$ ,  $u \in U$ , and  $\mu$ , a probability measure on  $X$ , we require that

$$Q_u(B) = \{(x, y) \mid f(x, u, y) \in B\} \quad (B \in B^n)$$

be measurable in the product measure  $\mu \times \lambda$ ; i.e.,  $Q(B)$  is a Borel set in  $R^{np}$ . Then Fubini's theorem guarantees that we can assign a unique measure to  $Q(B)$

$$\begin{aligned} \int_{Q_u(B)} d(\mu \times \lambda) &= \int_{R^n} \lambda\{y \mid (x, y) \in Q_u(B)\} d\mu \\ &= \int_{R^n} \mu\{x \mid (x, y) \in Q_u(B)\} d\lambda \end{aligned}$$

It can be verified that  $\mu'(B) = \int_{Q_u(B)} d(\mu \times \lambda)$  ( $B \in B^n$ ) is

another probability measure on the Borel sets of  $R^n$ , so define the mapping

$$F_u: \text{pm}(X) \times \text{pm}(R^p) \rightarrow \text{pm}(X)$$

where  $\text{pm}(X)$  is the set of all probability measures on  $X$ , by

$$F_u(\mu, \lambda) = \int_{Q_u(B)} d(\mu \times \lambda)$$

which represents the new probability measure on  $X$  after applying control  $u$ , given that the previous measure of  $X$  was  $\mu$ .

Proposition. If  $f$  is linear then  $F$  exists.

We can now define the set of Markov processes described in the beginning of this section. At each time  $T$  the closed loop state  $(x(T), z(T))$  is in the set  $X \times Z$ . Letting  $\delta_{z_i}$  be the vector in  $R^Q$  with 1 at position  $i$  and zero elsewhere, the probability measure at  $T = 0$  of  $(x(0), z(0))$  is:

$$\mu_0 \times \delta_{z(0)} \quad (T = 0, \mu_0 \in \eta_0)$$

for some  $\mu_0 \in \eta_0$ .

Suppose that the actual probability measures  $\mu_\sigma$ ,  $\lambda(0), \lambda(1), \dots \in \eta_\nu$  for the initial state and noise probabilities were known. Call this a Markov realization of the closed loop system. Then each Markov realization  $(\{\lambda(T)\}, \mu_0)$  will indeed be a Markov process with probability measures on the product space for  $T = 0, 1, \dots$ .

$$\{(\mu \times p)_T\}_{T=0,1,\dots}$$

if we define

$$(\mu \times p)_0 = \mu_0 \times \delta_{z(0)}$$

and

$$(\mu \times p)_{T+1} = \sum_{\substack{y \in Y \\ z \in Z \\ \mu_T(y) > 0}} \mu_T(y) [F_{\sigma(z,y)}(\mu_T(x \in C^{-1}(y)), \lambda_T) \times \delta_T(z,y)]$$

for  $T = 1, 2, \dots$ . It is clear from our definition of  $(\mu \times p)_{T+1}$  that the closed loop state will be a Markov process since the probability measure of  $(\mu \times p)_{T+1}$  depends only on the probability measure of  $(\mu \times p)_T$ .

We now define the closed loop system as the set of all probability sequences

$$\{(\mu \times p)_T\}_{T=0,1,\dots} \quad (2)$$

defined from the above equation (1) for all Markov realizations  $(\mu_0, \{\lambda(T)\})$ .

Also for each Markov realization let  $\{x(0), x(1), \dots\}$  be the random plant state and  $\{z(0), z(1), \dots\}$  be the random compensation state. Each set is a stochastic process but either taken alone is not in general a Markov process, since the statistics of the next compensator or plant state is determined by both the previous compensator state and plant state.

#### 2.4 Measures of Performance

To measure the performance of a compensator we will assume that a certain cost or penalty is expended at each point in time, (maybe zero), which depends on the plant state  $x(T)$ . Let

$$R: X \rightarrow [0, \infty]$$

be the mapping of states into appropriate costs. A cost of

infinity in some state be considered a "failure" or "catastrophe" at that time; any such state must be anticipated and avoided regardless of the cost accumulated on doing so. Of course,  $R$  can be defined in the range  $[0, \infty)$  if immediate failure is not a possibility. We make the following assumptions about  $C$ :

1) Let  $F$  be the set of  $x \in X$  such that  $R(x) = \infty$ . ( $F$  may be empty.) Then  $F$  is representable in  $N_x$ .

2)  $\sup\{C(x) : x \notin F\} < \infty$ .

Now we take, as our performance criterion, the highest average cost that could occur which we denote  $J$ . To make this precise, consider the random variable

$$y = \limsup_{T \rightarrow \infty} \frac{1}{T} \sum_{t=0}^T R(x(t))$$

of a particular Markov realization  $(\{\lambda(t)\}, \mu_0)$ .

The probability mass of  $y$  must lie within the interval  $[0, \infty]$ , and we denote the maximum cost from a Markov realization,  $J'_{\{\lambda\}, \mu} = \inf\{a : \Pr(y \leq a) = 1\}$ . We can then define the maximum average cost

$$J = \sup_{\substack{\{\lambda(t)\} \in \eta_V \\ \mu_0 \in \eta_0}} J'_{\{\lambda\}, \mu}$$

From this definition we conclude that:

1)  $J = \infty$  iff the system can fail, or more precisely, iff for some realization,  $x(t) \in F$  with nonzero probability for

some  $T \geq 0$ ;

$$2) \limsup_{T \rightarrow \infty} \frac{1}{T} \sum_{t=0}^T R(x(t)) \leq J \text{ with probability one for}$$

for realization, and there is a nonzero probability that

$$J - \epsilon \leq \limsup \frac{1}{T} \sum_{t=0}^T R(x(t)) \leq J$$

for some realizations for every  $\epsilon > 0$ .

Proof: These facts follow easily from the definitions. We will prove (1). Assume there is zero probability that  $x(t) \in F$  for every  $t \geq 0$ , every realization  $\{\lambda(T)\}$ ,  $\mu_0$ . Then every  $J'$  is bounded above by  $\sup\{R(x) : x \notin F\}$ , which by assumption is not  $-\infty$ , so  $J$  is also bounded from above.

## 2.5 Example: Tracking and Regulation

As an example of a possible performance criterion, suppose one wants to regulate or track or compensate against some unknown disturbances, and it is possible to include models of exogenous disturbances by augmenting the state space  $X$ . Then some linear combination of the states, say  $Dx$ , is required to be near zero. In the tracking problem, for example, one would subtract the actual state from the exogenous desired control state to get an error in the state which is to be cancelled.

Let, then,  $X$  denote the augmented state space, and let  $D$  be the linear observation map such that  $y = Dx$  is to be regulated near zero. If  $D$  is an onto map, we can redefine

coordinates of the state space so the  $D$  is just a projection, redefining  $f$  and all other maps on the state space suitably. We will not detail this procedure here but refer the reader to Wonham [7].

Assume then that by proper recoordination there is a subset of the state variables which are to be stabilized to zero. Denote this subvector of  $x$  by  $y$ . It would be sensible in most situations to define a failure zone  $F$  which  $y$  must not enter, and assuming  $y$  not in the failure zone, we might be interested in the maximum average error in  $y$  from 0. This cost corresponds to a

$$R(x) = \begin{cases} |y|^2 & y \notin F \\ \infty & y \in F \end{cases} .$$

We won't consider cost functions which include the control  $u$  or the compensator state  $z$ , in the present treatment.

## 2.6 Defining an Ambiguous Process for a Compensated System

In Section 2.2 we defined ambiguous measure spaces, and in Section 2.3 to 2.5 we defined the closed-loop system associated with a finite-state compensator and continuous plant. For the rest of this chapter we will assume that the plant and compensator are fixed, therefore all the quantities defined in Sections 2.3 to 2.5 are fixed, such as all the quantities in Table (1),  $\eta_v, \eta_o, \{(\mu \times p)_t\}$ , etc. We will show now that for any such compensated system, an ambiguous process can be defined, and that bounds on the performance of the original system can be derived from bounds on the ambiguous process.

To begin, we will repeat the general ideas in defining an ambiguous process, although somewhat differently than the discussion in Section 1.2 since our analysis will not take place in quite the same order.

Suppose that the compensated system is running and we observe its progress, watching carefully the compensator state, but not paying too much attention to the plant state  $x(T)$ . Let's say we observe the progress of the plant state only within some finite amount of detail, so at observation we distinguish between some finite number of conceptual areas; for example, whether the velocity is positive or negative, whether the magnitude of the position exceeds three, etc. In addition we might remember a few past observations. Just knowing the present conceptual area and a few past observations

will not, in general, enable us to make as good a prediction about the next state as if we had made precise measurements. On the other hand, the limited knowledge we do have will still narrow the chances of the various possibilities for the next state.

Now to take this idea one step farther, suppose we were interested only in predicting the next area of the plant state, rather than the exact plant state. Available to make this prediction is one of a finite number of recollections of the area of the plant state, and knowledge of the present compensator state, of which there are only a finite number of possibilities. By a "history" of the plant state we mean information up to and including the present area, so that a history of plant state may include some information about the present area. We will assume that the information about the present plant state area is sufficient to determine which control was applied, by always at least observing which coder equivalence area the state is in.

Given this finite information about the present state  $(x z)$ , there must be some range of probabilities for the probability of going to each conceptual area in the next step. Since the probabilities might depend on one another, we can at least say that there is some set of possible transition matrices. These possible transition matrices will be the ambiguous process associated with the feedback system, which, of course, depends on the choice of conceptual areas and

histories which will be remembered. Using an ambiguous process model, definite bounds on the performance of the compensator can be calculated, (and quite easily because of the finiteness of the model), and the structure of ambiguous processes.

Let us proceed with a more formal presentation. We mentioned that at each observation, at least the coder equivalence area should be determined; i.e., from our observation we should be able to identify

$$y = C(x)$$

where  $C$  is the coder function, otherwise we could not be sure of the value of the function  $\sigma(z, y)$ , i.e., the control applied. In our discussion here we will assume for simplicity that the conceptual areas of  $X$  just are the coder equivalence areas,  $C^{-1}(y)$ ,  $y \in Y$ . This leads us to

Definition. An immediate area of the finite-state feedback system is a vector  $(y \ z)^T$  where  $y \in Y$ ,  $z \in Z$ .

Definition. A history  $\pi$  is a finite string of immediate areas. Letting  $y_1, y_2, \dots, y_m \in Y$  and  $z_1, z_2, \dots, z_m \in Z$ , an example of a history might be the string

$$\pi = \begin{pmatrix} y_1 \\ z_1 \end{pmatrix} \begin{pmatrix} y_2 \\ z_2 \end{pmatrix} \dots \begin{pmatrix} y_m \\ z_m \end{pmatrix}$$

For any history we require that the following property hold between the elements of string (as shown above):

$$\tau(y_i, z_i) = z_{i+1} \quad \text{for all } i = 1, 2, \dots, m-1.$$

Definition. A conceptualization  $\Pi$  is a finite set of histories which includes every immediate area (this is possible since the number of immediate areas is finite).

To introduce the concept of a journal, consider the following example.

Example. Let  $Y = \{1, 2\}$ ,  $Z = \{1, 2\}$ , so the immediate conceptual areas are:

$$\left\{ \begin{pmatrix} 1 \\ 1 \end{pmatrix}, \begin{pmatrix} 1 \\ 2 \end{pmatrix}, \begin{pmatrix} 2 \\ 1 \end{pmatrix}, \begin{pmatrix} 2 \\ 2 \end{pmatrix} \right\}.$$

$$\text{Let } \Pi = \left\{ \begin{pmatrix} 1 \\ 1 \end{pmatrix}, \begin{pmatrix} 1 \\ 2 \end{pmatrix}, \begin{pmatrix} 2 \\ 1 \end{pmatrix}, \begin{pmatrix} 2 \\ 2 \end{pmatrix}, \begin{pmatrix} 1 \\ 1 \end{pmatrix} \begin{pmatrix} 2 \\ 1 \end{pmatrix}, \begin{pmatrix} 1 \\ 2 \end{pmatrix} \begin{pmatrix} 2 \\ 2 \end{pmatrix}, \begin{pmatrix} 1 \\ 1 \end{pmatrix} \begin{pmatrix} 2 \\ 1 \end{pmatrix} \begin{pmatrix} 2 \\ 2 \end{pmatrix} \right\}$$

It can be checked that  $\Pi$  is a conceptualization for  $\tau: Y \times Z \rightarrow Z$  given by the following table:

$\tau(y, z)$	$y = 1$	$2$
$z = 1$	1	2
2	2	1

Suppose now that at time  $T$ ,  $\pi(T) = \begin{pmatrix} 1 \\ 2 \end{pmatrix} \begin{pmatrix} 2 \\ 1 \end{pmatrix}$  is a history of the closed loop system. Then we can conclude that:

$$\begin{aligned} x(T) \in C^{-1}(2) & \quad z(T) = 1 \\ x(T-1) \in C^{-1}(1) & \quad z(T-1) = 2 \end{aligned}$$

Clearly  $z(T+1) = 2$ , so the next immediate area must be  $\binom{y}{2}$  where  $y = 1$  or  $2$ . Suppose  $y(T+1) \in C^{-1}(2)$ , so that  $\binom{2}{2}$  is the observation at  $T+1$ . What would be the best choice for  $\pi(T+1)$ ?

Clearly,  $\binom{2}{2}$  is reasonable, but not as complete a history as  $\binom{1}{1} \binom{2}{1} \binom{2}{2}$ . A history like  $\binom{1}{2} \binom{2}{2}$  is inconsistent with the past observations. Since  $\binom{1}{1} \binom{2}{2} \binom{2}{2}$  is the longest history in  $\Pi$  consistent with past observation, we choose A as the "best"  $\pi(T+1)$ .

Suppose now that  $y(T+1) \in C^{-1}(1)$ . Then the longest history in  $\Pi$  consistent with past observations must be  $\binom{1}{2}$ .  $\square$

The key observation in this example is that the "best" choice of  $\pi(T+1)$  of course depends on  $y(T+1)$ , which cannot be known with certainty. Still, we can define automaton on the history set  $\Pi$  which receives  $y(T)$  as input.

Definition. A journal  $\hat{\tau}$  is an automaton with state set  $\Pi$ , where  $\Pi$  is a conceptualization, and input set  $Y$  (dependent on  $\Pi$ ) which satisfies the following conditions. If

$$\begin{aligned} \pi \in \Pi \quad \text{and} \quad \pi &= \binom{y_1}{z_1} \binom{y_2}{z_2} \cdots \binom{y_m}{z_m} \\ y \in Y, \quad \text{and} \quad \hat{\tau}(\pi, y) &= \binom{y_1'}{z_1'} \binom{y_2'}{z_2'} \cdots \binom{y_m'}{z_m'} \end{aligned}$$

- then
1.  $\begin{pmatrix} Y_{m'} \\ Z_{m'} \end{pmatrix} = \begin{pmatrix} Y \\ \tau(Z_m, Y_m) \end{pmatrix}$
  2.  $m' \leq m+1$
  3. If  $m' > 1$ ,  $\begin{pmatrix} Y_{j+m'-m-1} \\ Z_{j+m'-m-1} \end{pmatrix} = \begin{pmatrix} Y_j \\ Z_j \end{pmatrix}$  for all  $j \in [m-m'+2, m]$
  4.  $\hat{\tau}$  maps every  $\pi$  to the longest possible string consistent with these conditions.  $\square$

The journal  $\hat{\tau}$  formalizes our notion of picking a "best" next history.

Proposition.  $\hat{\tau}$  is unique for every  $\Pi, Y$ .

Proof. Suppose  $\Pi, Y$  are fixed,  $\hat{\tau}_1$  and  $\hat{\tau}_2$  are two journals on these sets, and  $\hat{\tau}_1(\pi, y) = \pi_1$ ,  $\hat{\tau}_2(\pi, y) = \pi_2$  for  $\pi \in \Pi$ ,  $y \in Y$ . Condition (3) requires that if the length of  $\pi_1$  is the same as the length of  $\pi_2$ , then  $\pi_1 = \pi_2$ . Condition (4) thus makes  $\pi_1 = \pi_2$ , and since  $\pi$  and  $y$  were arbitrary,  $\hat{\tau}_1 = \hat{\tau}_2$ .  $\square$

Suppose now that the journal corresponding to some conceptualization  $\Pi$  were hooked up to the feedback system as an observer of the closed loop system, as we have illustrated below. Suppose the journal were started, at time one, rather than zero, in the state  $\begin{pmatrix} Y(0) \\ X(0) \end{pmatrix}$ . Then the reader can check from the definition of  $\hat{\tau}$  that the subsequent states  $\pi(t)$  of the journal all represent a correct history of the closed

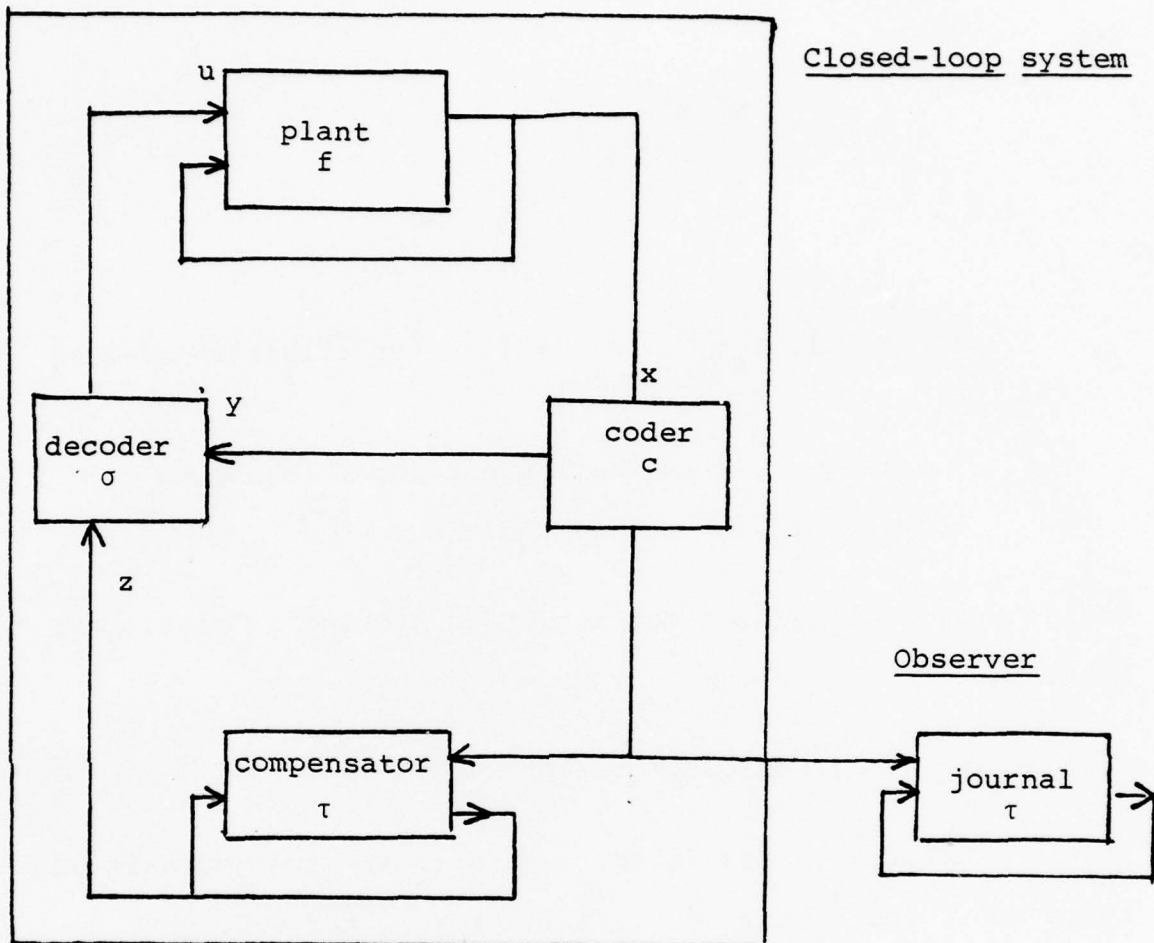

loop state; more specifically, if

$$\pi(t) = \begin{pmatrix} y_1 \\ z_1 \end{pmatrix} \dots \begin{pmatrix} y_m \\ z_m \end{pmatrix}, \quad t \geq 1,$$

then it must be true that

$$\begin{aligned} C(x(t-1)) &= y_m, & z(t-1) &= z_m \\ C(x(t-2)) &= y_{m-1}, & z(t-2) &= z_{m-1} \\ &\vdots & & \\ &\vdots & & \\ C(x(t-m)) &= y_1, & z(t-m) &= z_1. \end{aligned}$$

The converse is not true. Suppose  $\Pi$  contains the two histories

$$\pi_1 = \begin{pmatrix} y_1 \\ z_1 \end{pmatrix} \quad \text{and} \quad \pi_2 = \begin{pmatrix} y_2 \\ z_2 \end{pmatrix} \begin{pmatrix} y_1 \\ z_1 \end{pmatrix}$$

(and possibly others). Given that

$$C(x(t-1)) = y_1 \quad \text{and} \quad z(t-1) = z_1$$

does not imply that  $\pi(t) = \pi_1$ , for it may also be true that

$$C(x(t-2)) = y_2 \quad \text{and} \quad z(t-2) = z_2,$$

in which case  $\pi(t)$  could not be  $\pi_1$  but must be  $\pi_2$  or some other history, since  $\pi_2$  is a longer string consistent with these conditions. Nevertheless, by requiring that

$$C(x(t-2)) \neq y_2 \quad \text{and} \quad z(t-2) \neq z_2,$$

and some finite number of additional restriction on the past coder outputs and compensator states, we must be able to guarantee that  $\pi(t) = \pi_1$ . This set of events will be denoted  $\emptyset_{\pi_1}$ , or  $\emptyset_1$  for short.

Thus we can write

$$\pi(t) = \pi_1 \iff \emptyset_1(t)$$

Now consider any particular Markov Realization  $(\{\lambda(T)\}, \mu_0)$  of the closed loop system (see Section 2.3). We have shown that  $\left\{ \begin{pmatrix} x(t) \\ z(t) \end{pmatrix} \right\}$  is a Markov process. Since each event  $\theta_i(t)$  depends only on a finite number of points in time, we are led to the following:

Theorem. For any Markov Realization  $\{\lambda(T)\}, \mu_0$ ;  $\{\pi(t)\}$  is a stochastic process.

Proof. We will define this stochastic process by

- a) Defining the state space. It is just  $\Pi$ . ( $\pi(t)$  is not a state in the systems sense, but  $\pi(t)$  is the state of a stochastic process.)
- b) Taking Index Parameter  $t$  to be in  $Z^+$ .
- c) Defining, for a finite subset of indices  $t_1, t_2, \dots, t_n$ , the joint distribution of  $\pi(t_1), \dots, \pi(t_n)$  to be

$$P_r\{\pi(t_1) = \pi_1, \dots, \pi(t_n) = \pi_n\} = P_r\{\theta_1(t_1), \dots, \theta_n(t_n)\}$$

which is well defined because  $(x \ z)'$  is a Markov process, the sets of condition depend on only a finite number of time points, and each of the sets  $C^{-1}(y)$ ,  $y \in Y$ , is a Borel set by assumption, and this measurable by  $(\mu \times p)_T$ .  $\square$

We now give our first definition of the ambiguous process associated with  $\Pi$ .

Definition.  $\mathcal{A}_1(\Pi)$  is the set of all stochastic processes  $\{\pi(t)\}, \{\lambda(T)\}$   $\eta_V, \mu_0, \eta_0$ .

Now  $\mathcal{A}_1$  is one of those objects which could only in the most rare cases actually be calculated, and whose mere existence can, by many, be restricted to the domain of a lively mathematician's imagination. Our only ambition in making such an abstruse definition is to pinpoint exactly what it is we would ideally want the ambiguous process to be. For all practical purposes, the set  $\mathcal{A}_1$  must be padded out sufficiently that it admits some kind of analytical description, which can then be used to calculate the performance bounds. That is our next task.

First, let the number of elements in  $\Pi$  be  $N$ . Let  $\mathcal{P}_1, \dots, \mathcal{P}_N$  be closed, convex subsets of  $R^N$  such that for any  $p \in \mathcal{P}_1$ ,  $u^T p = 1$  and  $p \geq 0$  component arises, where  $u^T = (1 \ 1 \dots 1)$ . We will eventually interpret the  $p$ 's as probability vectors of going from one state to each of the  $N$  other states.

Consider the set of all finite length strings consisting of elements of  $\Pi$ ; denote it by  $\Pi^*$ .  $\omega_T$  will always denote an element of  $\Pi^*$  of length  $T$ .

Let  $i \in [1, N]$  and  $\omega_T \in \Pi^*$ . Let  $p_i(\omega_T)$  be an element of  $\mathcal{P}_i$ . Now consider a set of choices  $\{p_i(\omega_T)\}$  for all  $i = 1, 2, \dots, N$ ,  $\omega_T \in \Pi^*$ . Define a probability for each string in  $\Pi^*$  as follows:

$$1. \quad \Pr\{\pi_i\} = \begin{cases} 1 & \text{if } \pi_i = \pi(0) \\ 0 & \text{otherwise} \end{cases}$$

2. For any  $\omega_T \in \Pi^*$  of length  $T \geq 1$ , let  $\pi_i$  be the last element of  $\omega_T$ . Then define:

$$\begin{pmatrix} P_r\{\omega_T \pi_1\} \\ \vdots \\ P_r\{\omega_T \pi_N\} \end{pmatrix} = P_r\{\omega_T\} \cdot p_i(\omega_T)$$

where  $p_i(\omega_T) \in \rho_i$  is an N-vector.  $\square$

It is clear that the choice of the  $p_i(\omega_T)$ ,  $i = 1, \dots, N$ ,  $\omega_T \in \Pi^*$ , determine the probability of every string in  $\Pi^*$  uniquely. Furthermore, there is an obvious stochastic process for each set  $\{p_i(\omega_T)\}$ ; the axioms of probability can be checked, and a measure on every finite length string determines all the joint probability distributions. We denote the stochastic process by  $\mathcal{S}\{p_i(\omega_T)\}$ .

We are now ready to close the loop.

Definition. The ambiguous process on  $\rho_1, \dots, \rho_N$ , where  $\rho_i$  is a closed, convex subset of the probability vectors in  $R^N$ , is the set of all  $\mathcal{S}\{p_i(\omega_T)\}$ , for all possible sets  $\{p_i(\omega_T)\}$ , in which  $p_i(\omega_T) \in \rho_i$ ,  $i = 1, \dots, N \quad \forall \omega_T \in \Pi^*$ .

We shall often denote  $(\rho_1, \dots, \rho_N)$  by  $\rho$ . Our goal is now to find a  $\rho$  such that  $Q_1 \subset Q(\rho)$ .

Definition. A transition bound is a mapping (subscripted by  $u \in U$ )

$$\mathcal{F}_u: N_x \rightarrow N_x$$

such that

$$\mathcal{F}_u(\eta_x) = \{\mu: \mu = F_u(\mu', \lambda(T)), \mu' \in \eta_x, \lambda(T) \in \eta_v\}$$

Remark. <sup>The</sup> Transition bound always exists, since  $\eta_x \in N_x$ . (In Chapter 3 we will see that the right hand side is usually in  $N_x$  anyway, so <sup>no</sup> new bounding is necessary.) Let  $S_1, \dots, S_m$  be Borel sets in  $R^N$ .

Definition.

$$\varphi_{S_1, \dots, S_m}(\eta) = \left\{ \begin{pmatrix} \mu(S_1) \\ \mu(S_2) \\ \vdots \\ \mu(S_m) \end{pmatrix}, \mu \in \eta \right\} \quad v \in N_x$$

Definition. Let  $\pi = \begin{pmatrix} y_1 \\ z_1 \end{pmatrix} \begin{pmatrix} y_2 \\ z_2 \end{pmatrix} \dots \begin{pmatrix} y_m \\ z_m \end{pmatrix} \in \Pi$ .

$$\eta_\pi \triangleq P_{C-1(m)} \mathcal{F}_{\sigma(y_{m-1}, z_{m-1})} P_{C-1(y_{m-1})} \dots \mathcal{F}_{\sigma(y_1, z_1)} P_{C-1(y_1)} \xi$$

$$\pi \triangleq c[\text{cvxhull}[E_{C-1(1)}^{P_{C-1(1)}}, \dots, E_{C-1(r)}^{P_{C-1(r)}} (\mathcal{F}_{\sigma(y_m, z_m)}(\eta_\pi))]]$$

where  $E: R^r \rightarrow R^N$ ; if  $E(v)(i)$  is the  $i$ th component of  $E(v)$ ,  $v$  a vector in  $R^r$ ,

$$E(v)(i) = \begin{cases} 0 & \text{if } \forall y \in Y \quad \forall \pi \in \Pi, \hat{\tau}(\pi, y) \neq \pi_i \\ y_j & \text{where } y_j \text{ is the unique element of } Y \\ & \text{such that } \hat{\tau}(\pi, y_j) = \pi_i \end{cases}$$

and  $P_A$  is the projection operation defined in 2.2.  $\square$

These notational monstrosities actually turn out to be useful. We now complete this development of a simpler form for  $\mathcal{Q}_1(\Pi)$  in stating the following

Theorem.  $\mathcal{Q}(\mathcal{P}_{\pi_1}, \dots, \mathcal{P}_{\pi_N}) \supset \mathcal{Q}_1(\Pi)$ .

Proof. The reader should recognize, if he has studied the definitions carefully, that this theorem is really a notational paper dragon. We will go through a detailed proof to make the concepts more clear.

Let  $\mathcal{Q}_1(\Pi)$  be a stochastic process. By the definition of  $\mathcal{Q}_1$  there must be some  $\{\lambda(T)\}$   $\eta_V, \mu_0, \eta_0$  such that  $\{\pi(t)\}$  is the stochastic process associated with the journal  $\hat{\tau}$  of the closed-loop system. All we need to do to show  $\mathcal{Q} \in \mathcal{Q}(\mathcal{P})$  is to find some choice set  $\{p_i(\omega_T)\}$  which is consistent with  $\mathcal{P}$  and generates  $\mathcal{Q}$ . Consider any  $\omega_T \in \Pi^*$  and  $i = 1, 2, \dots, N$ . Let us calculate  $p_i(\omega_T)$  for the stochastic process  $\mathcal{Q}$ , so that we can show that  $p_i(\omega_T) \in \mathcal{P}_i$ , and then  $\{p_i(\omega_T)\}$  is consistent with  $\mathcal{P}$ .

Now

$$P_r(\omega\Pi) = \begin{pmatrix} P_r\{\omega_T\pi_1\} \\ \vdots \\ P_r\{\omega_T\pi_N\} \end{pmatrix} = \begin{pmatrix} P_r\{\pi(t+1)=\pi_1|\omega_T\} \\ \vdots \\ P_r\{\pi(t+1)=\pi_N|\omega_T\} \end{pmatrix} \cdot P_r\{\omega_T\}$$

so we identify  $p_i(\omega_T) = \begin{pmatrix} P_r\{\pi(t+1)=\pi_1|\omega_T\} \\ \vdots \\ P_r\{\pi(t+1)=\pi_N|\omega_T\} \end{pmatrix}$

Now all we need to do is show  $p_i(\omega_T) \in \mathcal{P}_i$ . Expand  $\omega_T$ :

$$\omega_T = \pi_1, \pi_2, \dots, \pi_5$$

Expand the  $\pi$ 's graphically:

$$\begin{aligned} \omega_T &= \begin{pmatrix} y_{11} \\ z_{11} \end{pmatrix} \\ &\quad \begin{pmatrix} y_{21} \\ z_{21} \end{pmatrix} \begin{pmatrix} y_{22} \\ z_{22} \end{pmatrix} \\ &\quad \begin{pmatrix} y_{31} \\ z_{31} \end{pmatrix} \begin{pmatrix} y_{32} \\ z_{32} \end{pmatrix} \begin{pmatrix} y_{33} \\ z_{33} \end{pmatrix} \\ &\quad \begin{pmatrix} y_{42} \\ z_{42} \end{pmatrix} \begin{pmatrix} y_{43} \\ z_{43} \end{pmatrix} \begin{pmatrix} y_{44} \\ z_{44} \end{pmatrix} \\ &\quad \quad \quad \begin{pmatrix} y_{55} \\ z_{55} \end{pmatrix} \\ &\quad \quad \quad \dots \\ &\quad \quad \quad \begin{pmatrix} y_{55-1} \\ z_{55-1} \end{pmatrix} \begin{pmatrix} y_{55} \\ z_{55} \end{pmatrix} \end{aligned}$$

Case 1.  $\omega_T$  inconsistent. If the y's and z's in some column don't agree,  $\omega_T$  is inconsistent, i.e.,  $P_r\{\omega_T\} = 0$ . Obviously,  $p_i(\omega_T)$  is not well-defined in this case, so we can choose it to be  $\rho_i$  if we wish.

Case 2.  $\omega_T$  consistent. Here obviously  $P_r\{\omega_T\} \geq 0$ , so again if  $P_r\{\omega_T\} = 0$ , we could still take  $p_i(\omega_T) \in \rho_i$ . The only remaining possibility is  $P_r\{\omega_T\} > 0$  and  $\omega_T$  consistent, which is what we're after.

Consider all the outcomes of  $\left\{ \begin{pmatrix} x(t) \\ z(t) \end{pmatrix} \right\}$  which would have caused  $\omega_T$ . We know this is nonempty since  $P_r\{\omega_T\} > 0$ .  $\pi_i$  is the last element of the string  $\omega_T$ , which is to say  $\pi(t) = \pi_i$ . Let

$$\pi_i = \begin{pmatrix} y_1 \\ z_1 \end{pmatrix} \cdots \begin{pmatrix} y_m \\ z_m \end{pmatrix} .$$

Consider, for each outcome in  $\left\{ \begin{pmatrix} x(t) \\ z(t) \end{pmatrix} \right\}$  which would have caused  $\omega_T$ , the probability measure of  $x(T-m-1)$ , call it  $\mu_{T-m-1}$ . Knowing that

$$\begin{array}{ll} Cx(T-1) = y_m, & z(T-1) = z_m \\ \vdots & \vdots \\ Cx(T-m) = y_1, & z(T-m) = z_1, \end{array}$$

and since  $(x \ z)$  is a Markov process, the measure of  $x(T-m)$  must be

$$P_{C^{-1}(y_1)} F_{\sigma(y_1 z_1)} \mu_{T-m-1} .$$

Thus we have

$$\mu_{T-1} = P_{C-1}(y_m)^{F_{\sigma}(y_{m-1}z_{m-1})} \cdots P_{C-1}(y_1)^{F_{\sigma}(y_1z_1)} \mu_{T-m-1}$$

Let  $\eta$  be the set of all possible  $\mu_{T-1}$ ; then by the definition of  $\mathcal{F}$ ,

$$\eta_{\pi} \supset \eta = \{P_{C-1(m)}^{\sigma(y_{m-1}z_{m-1})} \cdots P_{C-1}(y_1)^{F_{\sigma}(y_1z_1)} \mu_{T-m-1}\}$$

since  $F_{\sigma}(y_1z_1) \mu_{T-m-1}$  must be in  $\xi$ . The probability of getting each of the  $r$  coder outputs at time  $T$ , given some  $\mu_{T-1} \in \eta$ , is just

$$P_{C-1(1)} \cdots P_{C-1(r)}^{F_{\sigma}(y_m z_m)} (\mu_{T-1})$$

so these probability vectors must all lie in the set

$$P_{C-1(1)}, \dots, P_{C-1(r)} (\mathcal{F}_{\sigma}(y_m z_m) (\eta_{\pi})) .$$

We are almost there, as we now only need to check that the various probabilities for going to  $\pi_1, \dots, \pi_N$  are in  $\mathcal{P}_i$ . The function  $E$  is designed to "expand"  $T_{C-1(1)} \cdots P_{C-1(r)}$  just so this will be true.  $\square$

Example. We return to the example given in the Introduction, only formulated probabilistically so we can show how the ambiguous measure sets arise naturally in the analysis.

We take  $X = U = V = \mathbb{R}$ ,  $Z = \{z_1\}$ ,  $Y = \{y_0, y_1, y_2, y_3\}$ ,

$$f(x, u, v) = 3/2 x + u + v$$

$$\tau(y, z) = z$$

$$\sigma(y, z) = \begin{cases} +2 & \text{if } y = y_1 \\ 0 & \text{if } y = y_2 \\ -2 & \text{if } y = y_3 \\ 0 & \text{if } y = y_0 \end{cases}$$

$$C(x) = \begin{cases} y_0 & \text{if } x \in (-\infty, -2) \text{ or } (2, \infty) \\ y_1 & \text{if } x \in [-2, -1) \\ y_2 & \text{if } x \in [-1, 1] \\ y_3 & \text{if } x \in (1, 2] \end{cases}$$

Let  $N_x$  and  $N_v$  be as defined in Example 1, Section 2.2, with  $\eta_v = \{\lambda_v\}$  where  $\lambda_v$  is the uniform measure on  $[-1/2, 1/2]$ , and  $\eta_0 = \{\mu_0\}$  where  $\mu_0$  is the uniform measure on  $[-1, 1]$ . Thus there is only one possible Markov realization, so  $(x, z)^T$  is a Markov process.

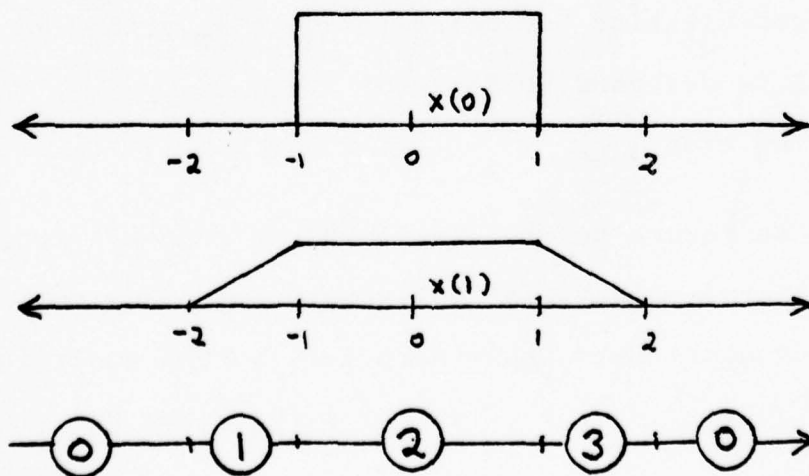

The performance criterion for this system is:

$$R(x) = \begin{cases} x^2 & \text{if } C(x) \neq y_0 \\ \infty & \text{otherwise} \end{cases}$$

To illustrate how ambiguous process  $\mathcal{A}(\mathcal{P})$  can be defined for this feedback-system, define a conceptualization:

$$\Pi = \left\{ \begin{pmatrix} y_0 \\ z_1 \end{pmatrix}, \begin{pmatrix} y_1 \\ z_1 \end{pmatrix}, \begin{pmatrix} y_2 \\ z_1 \end{pmatrix}, \begin{pmatrix} y_3 \\ z_1 \end{pmatrix}, \begin{pmatrix} y_1 & y_1 \\ z_1 & z_1 \end{pmatrix}, \begin{pmatrix} y_3 & y_3 \\ z_1 & z_1 \end{pmatrix} \right\}$$

and a transition bound:

$$\mathcal{F}_u : N_x \rightarrow N_x .$$

Recall that  $\mathcal{F}_u$  is a transition bound if for every  $\eta_x \in N_x$ ,

$$\mathcal{F}_u(\eta_x) \supset \{ \mu : \mu = F_u(\mu', \lambda(T)), \mu' \in \eta_x, \lambda(T) \in \eta_v \}$$

We digress momentarily to discuss  $F_u(\mu', \lambda)$ , which is defined by  $f$ . Let  $(2/3\mu')$  be the measure defined by:

$$(2/3\mu')(B) = \mu'(2/3B) \quad (B \in B)$$

If the measure of  $x(T)$  is  $\mu'$ , then the measure of  $3/2x(T)$  is  $(3/2\mu')$ , and the measure of  $3/2x(T) + v(T)$  is  $(2/3\mu') * \lambda$  so

$$F_u(\mu', \lambda)(B) = [(2/3\mu') * \lambda](B-u) \quad (B \in B)$$

We will not use this formula for  $F_u$  explicitly because we will be able to derive the result intuitively for the simple  $\mu, \lambda$  in question.

For any probability measure  $\mu$  there is some set  $S$  such that  $\mu(S) = 1$ . The support of  $\mu$  is the infimal  $S$  with this property. If  $\eta_x$  is a set of measures, the infimal support of  $\eta_x$ , denoted by  $\text{infsp}(\eta_x)$ , is the infimal  $S$  such that  $\mu(S) = 1$  for all  $\mu \in \eta_x$ . We now take as a transition bound:

$$u(\eta_x) = \xi_{\text{infsp}(F_u(\eta_x, \lambda_v))}^1$$

which clearly satisfies the necessary properties.

These two items, the conceptualization  $\Pi$  and the transition bound are all that is needed to define the ambiguous process  $\mathcal{A}(\mathcal{P})$ . We start by computing the  $\eta_\pi$  for  $\pi \in \Pi$ . Let  $\pi = \begin{pmatrix} y_1 \\ z_1 \end{pmatrix}$ , for example. Then

$$\eta_\pi \triangleq P_{C-1}(y_1)^\xi = \xi_{[-2, -1]}$$

It is more difficult to derive a  $\eta_\pi$  for a history such as  $\pi = \begin{pmatrix} y_1 \\ z_1 \end{pmatrix} \begin{pmatrix} y_1 \\ z_1 \end{pmatrix}$ , for

$$\eta_\pi = P_{C-1}(y_1) \circ (y_1, z_1) P_{C-1}(y_1) \xi_{11}$$

The first step is to compute

$$\mathcal{F}_{\sigma(y_1 z_1)} P_{C^{-1}(y_1)}^\xi = \mathcal{F}_{+2}^\xi[-1, -1]$$

If  $x \in [-2, -1]$ , then  $3/2x + u \in [-1, 1/2)$  and  $3/2x + u + v \in [-3/2, 1)$ .

We conclude that  $\text{infsp}(F_2([-2, -1], \lambda_v)) = [-3/2, 1)$ , so

$$\mathcal{F}_{+2}^\xi[-2, -1) = \xi(-3/2, 1)$$

Finally,  $\eta_\pi = P_{C^{-1}(y_1)}^\xi(-3/2, 1) = P_{[-2, -1)}^\xi[-3/2, 1) = \xi[-3/2, 1)$ .

The  $\eta_\pi$ ,  $\pi \in \Pi$ , are summarized in the table below.

$\pi$	$\eta_\pi$
$\pi_1 = (y_1 z_1)$	$\xi[-2, -1)$
$\pi_2 = (y_2 z_1)$	$\xi[-1, 1)$
$\pi_3 = (y_3 z_1)$	$\xi(1, 2]$
$\pi_4 = (y_0 z_1)$	$\xi[-\infty, -2) \quad (2, +\infty]$
$\pi_5 = (y_1 z_1)(y_1 z_1)$	$\xi[-3/2, -1)$
$\pi_6 = (y_3 z_3)(y_3 z_3)$	$\xi(1, 3/2]$

We can now compute  $\rho_i$ ,  $i = 1, \dots, 6$ , where the histories are indexed as shown in the preceding table. Let us take as an example the computation of  $\rho_1$ :

$$\rho_1 = \mathbb{E}^{\mathbb{P}_{C^{-1}(1), \dots, C^{-1}(4)}} \mathcal{F}_{\sigma(z_1, y_1)}^{(\xi)}[-2, -1]$$

First we tackle the problem

$$\mathbb{P}_{C^{-1}(1) \dots C^{-1}(4)} \mathcal{F}_2^\xi[-2, -1]$$

$$= \mathbb{P}_{[-2, -1], [-1, 1], (1, 2), (-\infty, -2) \cup (2, \infty)} \mathcal{F}_2^\xi[-2, -1]$$

We will find the solution intuitively. Suppose  $x(T) \in [-2, -1]$ ; then

$$x(T+1) \in 3/2[-2, -1] + 2 + v(T)$$

$$\in [-1, 1/2] + v(T)$$

Since  $|v(T)| \leq 1/2$ , the probability that  $x(T+1) \in [-\infty, -2)$ , is zero, i.e.,

$$\mathbb{P}_{[-\infty, -2)} [\mathcal{F}_2^\xi[-2, -1]] = 0;$$

and also

$$\mathbb{P}_{(-2, \infty)} [\mathcal{F}_2^\xi[-2, -1]] = \mathbb{P}_{(1, 2)} [\mathcal{F}_2^\xi[-2, -1]] = 0.$$

The probability that  $x(T+1) \in [-2, -1]$  is between 0 and 1/2, depending on the exact probability measure for  $x(T)$ . Thus

$$\mathbb{P}_{C^{-1}(1) \dots C^{-1}(4)} \mathcal{F}_2^\xi[-2, -1] = \left\{ \begin{pmatrix} 1-a \\ 0 \\ 0 \end{pmatrix} : a \in [0, 1/2] \right\}.$$

Finally,  $\rho_1 = \text{cl} [\text{cvxhull}[\mathbb{E}\{\begin{pmatrix} 1-a \\ 0 \\ 0 \end{pmatrix} : a \in [0, 1/2]\}]]$

To see just what  $E$  does, suppose that for some  $T$ ,  $\pi(T) = \begin{pmatrix} y_1 \\ z_1 \end{pmatrix}$ .

From the above computation we know that the probability of  $x(T+1) \in C^{-1}(y_1)$  is  $a$ , where  $a$  is between 0 and 1/2. Hence there is a probability between 0 and 1/2 that

$$\pi(T+1) = \pi_S = \begin{pmatrix} y_1 \\ z_1 \end{pmatrix} \begin{pmatrix} y_1 \\ z_1 \end{pmatrix}. \text{ Similarly there is a probability}$$

between 1/2 and 1 that  $x(T+1) \in C^{-1}(y_2)$ , so

$$\pi(T+1) = \pi_2 = \begin{pmatrix} y_2 \\ z_1 \end{pmatrix} \text{ with probability between 1/2 and 1. There}$$

is no probability that  $\pi(T+1)$  is  $\pi_1, \pi_3, \pi_4, \pi_6$ . Thus

$$E \left\{ \begin{pmatrix} a \\ 1-a \\ 0 \\ 0 \end{pmatrix} : a \in (0, 1/2] \right\} = \left\{ \begin{pmatrix} 0 \\ 1-a \\ 0 \\ 0 \\ a \\ 0 \end{pmatrix} : a \in (0, 1/2] \right\}$$

Since this set is closed and convex it is just  $\mathcal{P}_1$ .

$\mathcal{P}_2, \dots, \mathcal{P}_6$  can be computed similarly and are:

$$\mathcal{P} = (\mathcal{P}_1 \dots \mathcal{P}_6) = \begin{pmatrix} 0 & [0,1] & 0 & [0,1] & 0 & 0 \\ [1/2,1] & [0,1] & [1/2,1] & [0,1] & 1 & 1 \\ 0 & [0,1] & 0 & [0,1] & 0 & 0 \\ 0 & 0 & 0 & [0,1] & 0 & 0 \\ [0,1/2] & 0 & 0 & [0,1] & 0 & 0 \\ 0 & 0 & [0,1/2] & [0,1] & 0 & 0 \end{pmatrix}$$

where we have simplified the notation (no information has been lost). Another convenient representation is shown in Figure (2.1). Here (33) stands for  $\pi_6$ , i.e.,  $\begin{pmatrix} y_3 \\ z_1 \end{pmatrix} \begin{pmatrix} y_3 \\ z_1 \end{pmatrix}$ .

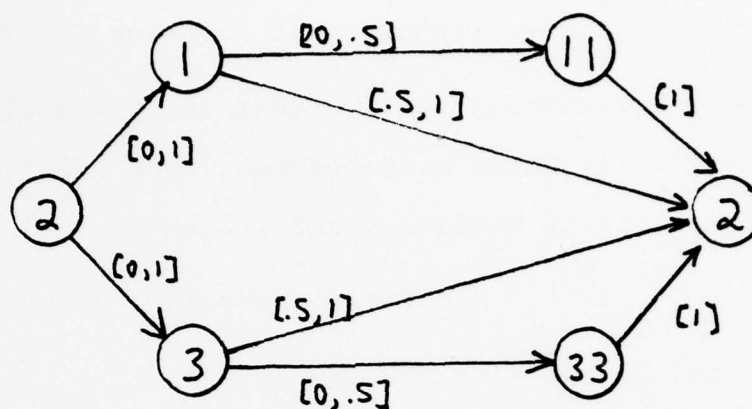

Figure 2.1

We can now immediately see that since  $\pi(0) = \pi_2$ ,  $x(T)$  will never exceed 2 since all supports of the above histories lie in  $[-2, 2]$ .

We can also calculate maximum square deviation for each  $\pi \in \Pi$ ; they are

History	Maximum square error
0	$\infty$
1	4
2	1
3	4
11	9/4
33	9/4

Table 2

and bound to the mean square error we rely on a theorem to be proved: that some choice of the transition probabilities (in Figure 2.1), all at their extreme points, will give a lower bound on the mean square error. This lower bounds even

the nonstationary possibilities. Using this theorem it is easy to see that a lower bound will occur by choosing the probabilities as shown in Figure 2.2:

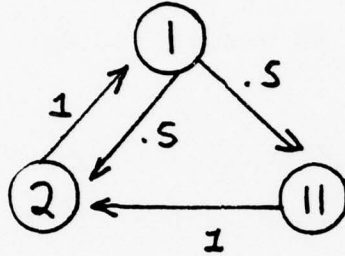

Figure 2.2

The steady-state probabilities are:

History	1	2	11
S.S. Prob	2/5	2/5	1/5

so the maximum square error is  $2/5(1) + 2/5(4) + 1/5(9/4) = 2.45$  and thus the worst root square mean error is 1.57.  $\square$

## 2.7 Bounds on Performance

In this brief section we will show how the performance of a compensated system can be related to the performance of an associated ambiguous process.

Definition. Let  $\mathcal{S} \in \mathcal{A}$  be a stochastic process. Define, in parallel to our earlier definitions,

$$\hat{J}(\mathcal{S}) = \inf \left\{ a: \Pr \left\{ \limsup_{T \rightarrow \infty} \frac{1}{T} \sum_{t=0}^T r(\pi(t)) < a \right\} = 1 \right\}$$

$$\hat{J}(\mathcal{A}) = \sup \{ b: b = \hat{J}(\mathcal{S}), \mathcal{S} \in \mathcal{A} \}$$

where  $r(\pi_i) \triangleq \sup \{ R(x): C(x) = y_i \}$ ,

$$\pi_i = \begin{pmatrix} y_1 \\ z_1 \end{pmatrix} \cdots \begin{pmatrix} y_m \\ z_m \end{pmatrix}$$

Proposition.  $J \leq \hat{J}$  for  $\mathcal{A}$  an ambiguous process model of the closed loop system.

Proof: Suppose  $\{ \lambda(T) \}$ ,  $\mu_0$  is a Markov realization.

If  $\limsup_{T \rightarrow \infty} \frac{1}{T} \sum_{t=0}^T r(\pi(t)) < a$  then

$$\limsup_{T \rightarrow \infty} \frac{1}{T} \sum_{t=0}^T R(x(t)) < a$$

so

$$J(\mathcal{S}_{\{\lambda(T)\}}, \mu_0) \geq J_{\{\lambda(T)\}}, \mu_0$$

$$\rightarrow J \leq \hat{J}$$

In the previous sections we have seen that any finite-state control system can be modeled as an ambiguous process  $\mathcal{A}(\mathcal{P})$ , given a conceptualization  $\Pi$  and transition bound  $\mathcal{F}$ . Of course the computation of  $\mathcal{P}$  directly from the formulas given there are still out of the practical realm, but we postpone the discussion of the practicalities of this computation to Chapter 3 so that the general theoretical development can be continued. Let us begin with a brief review of ambiguous processes as defined haphazardly in previous sections.

Defn.  $p \in \mathbb{R}^N$  is a probability vector if  $(1 \cdots 1)p = 1$ , and  $p \geq 0$  component-wise.

Defn. An ambiguous process  $\mathcal{A}$  on a finite state set  $X$  is an  $N$ -tuple of closed, convex subsets of probability vectors in  $\mathbb{R}^N$ . We will denote these subsets by  $\mathcal{P}_1, \dots, \mathcal{P}_N$ ,  $\mathcal{A} = (\mathcal{P}_1 \dots \mathcal{P}_N)$ , and  $\mathcal{P}$  the set of all matrices with the  $i^{\text{th}}$  column from  $\mathcal{P}_i$ .

(We choose  $X$  here for the state set to avoid having so many " $\pi$ "s in the text.)

Defn. The stochastic processes associated with  $\mathcal{P}$  are all those that assign probabilities to elements of  $X^*$ , the strings of finite length from set  $X$ , such that:

1.  $P_r \{ \pi_i \}$  is zero for all but one  $X_i$ , call it  $X_0$ .
2. If  $\omega_T \in X^*$ , let the length of  $\omega_T$  be  $T \geq 1$ , let  $X_i$  be the last element of the string. Then there must be some  $P_i(\omega_T) \in \mathcal{P}_i$  such that

$$\Pr(\omega_T X) = \Pr\{\omega_T\} \cdot P_i(\omega_T)$$

$$\text{where } \Pr(\omega_T X) = \begin{pmatrix} \Pr\{\omega_T X_1\} \\ \vdots \\ \Pr\{\omega_T X_N\} \end{pmatrix}$$

□

Let  $r: X \rightarrow [0, \infty]$  and define  $J(\mathbf{a})$  as in section 2.7. Our goal in the next sections will be to establish that for some  $p^* \in P$ ,

$$J \leq \zeta(P^*)$$

where  $\zeta$  is the "cost" function for a Markov process, defined in terms of limiting state probabilities. We will go on to further characterize  $P^*$  by saying that for some vector  $h$ , each column of the row vector

$$h^T P^*$$

is maximum over all  $p \in P$ . For certain cases of  $P$  the condition becomes even simpler. These facts make ambiguous processes genuinely useful for determining bounds, and this will be fully explored in Chapter 3. For now let us outline

the progression in the remainder of Chapter 2. First, we will review the standard results on finite-state Markov Processes, then take up differential properties of limiting state probabilities, and define the function  $\zeta$ . The first result will be that  $\zeta$  has a maximum in  $\mathcal{P}$ . This maximum will then be shown to bound  $J$ , and necessary conditions on  $\mathcal{P}^*$  will be derived.

### 2.9 Markov Processes

Suppose  $\mathcal{P} = P$  consists of a single matrix. Then  $\mathcal{Q}(\mathcal{P})$  is a Markov process; to see this, let  $\omega_T$  be an outcome to time  $T$ ,  $(x_{i_1}, x_{i_2}, \dots, x_{i_T})$ , and for any  $x_{i_{T+1}}$ ,

$$\begin{aligned}
 P_r\{\omega_T, x_{i_{T+1}}\} &= P_r\{\omega_T\} P(i_T, i_{T+1}) \\
 \text{so } P_r\{x_{i_{T+1}} \mid \omega_T\} &= \frac{P_r\{\omega_T, x_{i_{T+1}}\}}{P_r\{\omega_T\}} = P(i_T, i_{T+1}) \\
 &= P_r\{x_{i_{T+1}} \mid x_{i_T}\}
 \end{aligned}$$

So in this section we will take up a "special case" of ambiguous process, namely a Markov process. We denote a Markov process by its  $N$  by  $N$  transition matrix  $P$ . We will differ from the standard arrangement of probabilities in a stochastic matrix by requiring that the columns, rather than

the rows, sum to one, but of course require that every element of  $P$  be nonnegative. We are now consistent with the format of matrices in the set  $\mathcal{P}$  associated with any ambiguous process.

A standard result from the theory of Markov process  $P$  can be partitioned in to classes of the following kind (see, for example, Gantmacher [13], Vol II):

- 1) Transient
- 2) Ergodic
- 3) Cyclic

so that the probability of making a transition from one non-transient class to any other class is zero, and each kind of class has certain characteristic properties.

The probability of the state being in a transient state more than a finite number of times is zero. This is the characterization of transient states.

For Ergodic classes, states reoccur infinitely often, and furthermore, the probability of being in any state  $x_i$  becomes independent of the initial state, and grows toward a constant as  $T$  gets large.

For Cyclic classes, states reoccur infinitely, but unlike ergodic classes, the progression of the states with time follows a strict circular sequence.

Now suppose that  $x_0$ , the starting state, is deterministic. Only certain of the transient, ergodic and cyclic classes are reachable with non-zero probability from  $x_0$ , and in this analysis we will only be interested in the ergodic or cyclic classes reachable from  $x_0$ , which will be denoted  $O_{x_0} = \{D_i\}$ , or  $O$  for short, where each  $D_i$  is an ergodic or cyclic class.

Defn. A set of states is unified if it forms an ergodic or cyclic class. If the entire set of states of  $P$  is unified, then we say that  $P$  is unified.

The transient and unified classes of a general stochastic matrix can be represented by an illustration, or by a block diagonal matrix as shown below. We will always restrict our attention to those classes which are reachable from  $x_0$ .

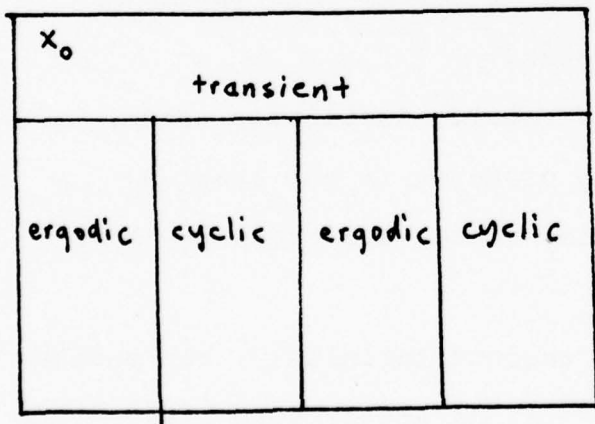

a) Diagram

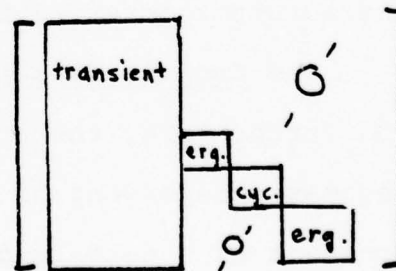

b) Block Matrix

If  $D_i \in \mathcal{D}$  is a unified class, let  $P_{D_i}$  be the block of the matrix  $P$  corresponding to the intra-transition probabilities for the states in  $D_i$ . Clearly, by the block diagonal structure of  $P$  (excluding transient states),  $P_{D_i}$  will again be a stochastic matrix.

A property of ergodic classes is that there must be a vector of limiting state probabilities, which obeys

$$P_{D_i} p_\infty = p_\infty, \quad U^T p_\infty = 1, \quad p_\infty \geq 0 \quad (U^T = (1 \cdots))$$

where  $D_i$  is the ergodic class. This leads us to a natural definition of the average cost of being in  $D_i$ ,

$$c_\infty(D_i) = \sum_{j=1}^N c(x_j) p_\infty(j)$$

For cyclic classes it is equally easy to define an average cost. Suppose we took it to be

$$\lim_{T \rightarrow \infty} \frac{1}{T} \sum_{t=1}^T c(x(t))$$

Since, given a starting state  $x_0 \in D'_i$  in cyclic class  $D'_i$ , the  $x(t)$  must follow a prescribed circle  $x_1, x_2, \dots, x_m$ , the above limit must converge to

$$c_\infty(D'_i) \triangleq \frac{1}{m} \sum_{j=1}^m c(x_m)$$

Furthermore, since we assume there is some probability of entering each  $D_i \in \mathcal{D}$  from  $x_0$ , it is only logical to define

$$\zeta(P) = \sup_{D_i \in \mathcal{D}} c_{\infty}(D_i)$$

to represent "average" cost.

One further property that will be useful in the sequel is the following:

Proposition. Let  $P$  be unified. Then either:

1. all eigenvalues but one have magnitude less than one;
- or
2.  $P$  is cyclic

Proof: Refer to Gantmacher [13], Vol. 2, p. 88.

#### 2.10 Differential Properties of Markov Processes

We are interested here in the behaviour of  $\zeta$  when small changes are made in  $P$ . To this end we define a feasible direction  $\Delta$  to be an  $N$  by  $N$  matrix such that for small enough  $\epsilon > 0$ ,  $P + \epsilon\Delta$  is a stochastic matrix. Of course, for  $\Delta$  to be a feasible direction,  $u^T \Delta$  must be zero. If  $P - \epsilon\Delta$  is a stochastic matrix as well, we say that  $\Delta$  is a bifeasible direction.

By

$$\frac{d\zeta}{d\Delta}$$

we will always mean

$$\frac{d \zeta(P + \epsilon\Delta)}{d\epsilon}$$

and this applies as well to any other functions of  $P$ , such as  $p_{\infty}$ ,  $c_{\infty}$ , etc.

Theorem. Let  $P$  be ergodic and let  $\Delta$  be a bifeasible direction.

Then

$$M = \sum_{n=0}^{\infty} P^n \Delta$$

exists, and

$$\frac{dp_{\infty}}{d\Delta} = Mp$$

$$\frac{dM}{d\Delta} = M^2.$$

Proof: Since  $P$  is ergodic, there must be a  $p_{\infty}$  with  $Pp_{\infty} = p_{\infty}$ . Since  $\Delta$  is bifeasible, no element  $P(i,j)$  can be zero in  $P$  if  $\Delta(i,j) \neq 0$ , thus for small enough  $\epsilon$ ,  $P \pm \epsilon \Delta$  will be non-zero everywhere  $P$  is non-zero, so  $P \pm \epsilon \Delta$  will be ergodic and

$$(P + \epsilon \Delta)p_{\infty}(\epsilon) = p_{\infty}(\epsilon)$$

Rewrite these equations as

$$(I - P) \left( \frac{p_{\infty}(\epsilon) - p_{\infty}}{\epsilon} \right) = \Delta p_{\infty}(\epsilon)$$

Let us turn to the infinite sum  $M$ .

Let  $v$  be an eigenvector of  $P$ ,  $Pv = \lambda v$ ,  $|\lambda| = 1$ . If  $\lambda = 0$ , then  $Pv = 0$ , and since  $u^T P = u^T$ ,  $u^T v = 0$ . On the other hand, if  $0 < |\lambda| < 1$ , then

$$u^T P v = u^T v = u^T \lambda v$$

so again  $u^T v = 0$ . ( $u^T = (1 \ 1 \ \dots \ 1)$ ). Thus, if  $|\lambda| < 1$ , then  $u^T v = 0$ . But

for an ergodic matrix  $P$ , the proposition guarantees that all  $|\lambda| < 1$  except for one eigenvalue corresponding to  $p_{\infty}$ . Let  $\Delta_i$  be any column of  $\Delta$ , and suppose that  $P$  has a full set of eigenvectors. Then  $\Delta_i$  could not have any component in the direction of  $p_{\infty}$ ; if

$$\Delta_i = c_1 v_1 + \dots + c_N v_N$$

then taking  $v_1 = p_{\infty}$ ,

$$0 = u^T \Delta_i = c_1 u^T p_{\infty} + \dots + c_N u^T v_N = c_1$$

so  $c_1=0$ . For the case of a full set of eigenvectors, then  $M$  must exist because every eigenvector component in  $\Delta_i$  has magnitude less than one. This argument can be extended to  $P$  not having full set by using extended eigenvectors.

Since

$$M = \sum_{n=0}^{\infty} P^n \Delta$$

$M$  must satisfy the equation:

$$(I-P)M = \Delta$$

and thus:  $(I-P)M p_{\infty}(\epsilon) = \Delta p_{\infty}(\epsilon)$

Since

$$(I-P) \left( \frac{p_{\infty}(\epsilon) - p_{\infty}}{\epsilon} \right) = \Delta p_{\infty}(\epsilon),$$

and by the additional constraints

$$u^T \left( \frac{p_{\infty}(\epsilon) - p_{\infty}}{\epsilon} \right) = 0$$

$$u^T M p_{\infty}(\epsilon) = 0$$

we must have (since the rank of  $I-P$  is  $N-1$ ):

$$\frac{p_{\infty}(\epsilon) - p_{\infty}}{\epsilon} = M p_{\infty}(\epsilon)$$

Certainly

$$\lim_{\epsilon \rightarrow 0} M p_{\infty}(\epsilon) = M p_{\infty} = \lim_{\epsilon \rightarrow 0} \frac{p_{\infty}(\epsilon) - p_{\infty}}{\epsilon} = \frac{dp_{\infty}}{d\Delta}$$

Similarly

$$\frac{M(\epsilon) - M}{\epsilon} = M M(\epsilon)$$

so

$$M^2 = \frac{dM}{d\Delta}$$



Now let us turn to the properties of  $\zeta$ . For an ergodic  $P$ ,  $\zeta(P) = c^T P$ . Suppose that  $\mathcal{P}$  is a closed, convex set of ergodic  $P$ , in which the columns are independent (c.f. section 2.8.)

Theorem. For the  $\mathcal{P}$  described above,  $\zeta$  achieves a maximum at an extreme point in  $\mathcal{P}$ . Furthermore, for some  $h$ ,  $h^T P^* \geq h^T P$  (componentwise) for all  $P \in \mathcal{P}$ .

Proof: Since every  $P \in \mathcal{P}$  is ergodic, and  $\mathcal{P}$  is closed, then  $\zeta$  is differentiable on  $\mathcal{P}$ , hence (Avriel [15])  $\zeta$  achieves a maximum somewhere in  $\mathcal{P}$ , call it  $P^*$ . At  $P^*$  we must have

$$\frac{d\zeta}{d\Delta} \leq 0$$

for all feasible  $\Delta$ . Write  $\Delta = (\Delta_1 \ \Delta_2 \ \dots \ \Delta_N)$  and let

$$\hat{\Delta} = \begin{pmatrix} 0 & -1 & -1 & \dots & -1 \\ 0 & 1 & 0 & \dots & 0 \\ 0 & 0 & 1 & \dots & 0 \\ \vdots & \vdots & \vdots & \ddots & \vdots \\ 0 & 0 & 0 & \dots & 1 \end{pmatrix}, \quad h^T = c^T M(\hat{\Delta}). \quad \text{Then } c^T M(\Delta_i) = (0 \ \dots \ h^T \Delta_i \ \dots \ 0)$$

and  $c^T M(\Delta) = h^T \Delta$ . Since

$$\frac{d\zeta}{d\Delta} = c^T M(\Delta) p_\infty = h^T p_\infty \leq 0$$

we conclude that  $h^T \Delta \leq 0$  (since  $p_\infty > 0$ ) and thus

$$h^T (P^* + \Delta) = h^T P^* + h^T \Delta \leq h^T P^*$$

Furthermore this condition can always be achieved at an extreme point.  $\square$

Corollary. Suppose the simplexes  $\mathcal{P}_i$  are defined by

$$\mathcal{P}_i = \left\{ \begin{pmatrix} p_{i1} \\ p_{i2} \\ \vdots \\ p_{iN} \end{pmatrix} : p_{i1} \in [l_1, l_1'], p_{i2} \in [l_2, l_2'], \dots, p_{iN} \in [l_N, l_N'] \right. \\ \left. \sum_{j=1}^N p_{ij} = 1 \right\}$$

where all  $0 < l_j < 1$ . Then  $\mathcal{P}$  satisfies the conditions of the previous theorem, and  $P^*$  depends only on the ranking of the elements in the vector  $h$ .

Proof: For the simplex in  $R^N$  defined by each  $\mathcal{P}_i$ , the solution to  $h^T \mathcal{P}_i^* \leq h^T \mathcal{P}_i$  will be achieved by putting the greatest amount of probability mass in the component with highest  $h$  multiplier, and so forth. Thus  $\mathcal{P}^*$  depends only on the ranking of the components of  $j$  from the least to greatest.  $\square$

### 2.11. Maximization of $\zeta$ in $\mathcal{P}$

We now take up the general question of the existence of a maximal  $\zeta(\mathcal{P}^*)$  in an arbitrary  $\mathcal{P}$  satisfying the conditions for an ambiguous process. Elegant results are obtained by restricting  $\mathcal{P}$  to be ergodic, and were derived in Section 2.10. The same results are true for the general case, namely, that  $\mathcal{P}^*$  is an extreme point, and that for some  $h$ ,  $h^T \mathcal{P}^*$  is minimized componentwise, but unfortunately the proofs are very tedious. We will outline here the proof that  $\mathcal{P}^*$  exists.

Theorem.  $\zeta_{x_0}$  attains a maximum in  $\mathcal{P}$ . (We show the explicit dependence of  $\zeta$  on  $x_0$  because, for general  $\mathcal{P}$ ,  $\zeta$  is not well-defined if a starting state is not specified.)

Outline of Proof: We will only sketch out the major ideas. Assume to the contrary that no maximum exists. Then there must be an ascending sequence  $(\zeta(\mathcal{P}_1), \zeta(\mathcal{P}_2), \dots)$  with no upper bound  $\zeta(\mathcal{P}^*)$  in  $\mathcal{P}$ . We will derive a contradiction.

Let the sequence  $\{\mathcal{P}_i\}$  be such that the  $\zeta_{x_0}$  of each  $\mathcal{P}_i$  is the same; this is possible since the number of states, and hence the number of partitions, is finite. Furthermore, let  $\{\mathcal{P}_k\}$  be a sub-

sequence which converges, say to  $\bar{P}$ . Since  $\mathcal{P}$  is compact,  $\bar{P} \in \mathcal{P}$ . The partition of each  $P_k$  is the same, but the partition of  $\bar{P}$  may be different. Let us consider the possibilities.

If  $x_1$  and  $x_2$  were in different classes in  $\mathcal{D}$ , the partition of each  $P_k$ , they must be in different classes in  $\bar{\mathcal{D}}$ , the partition of  $\bar{P}$ , since  $\lim_{k \rightarrow \infty} P(x_1, x_2) = 0$ . Any cyclic class in  $\mathcal{D}$  must also be cyclic in  $\bar{\mathcal{D}}$ , although the class may not be in  $\bar{\mathcal{D}}$  if they are not reachable from  $x_0$ .

Of the transient states in  $\mathcal{D}$ , some may break off into unified classes in  $\bar{\mathcal{D}}$ , or become unreachable entirely. Similarly, ergodic classes in  $\bar{\mathcal{D}}$  may fragment into transient, ergodic, and cyclic subclasses. This is illustrated below.

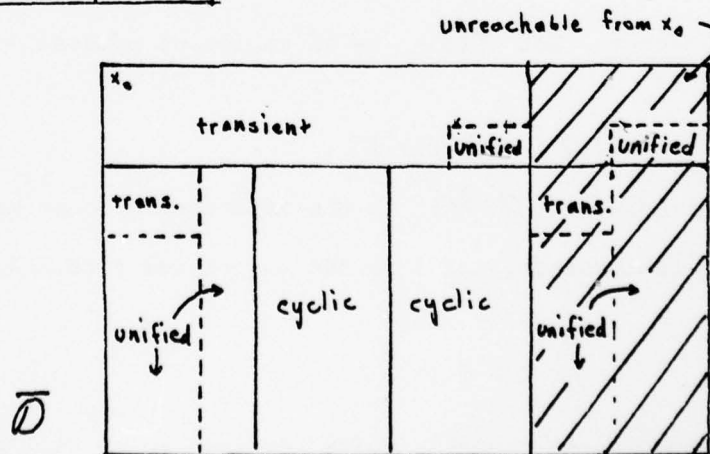
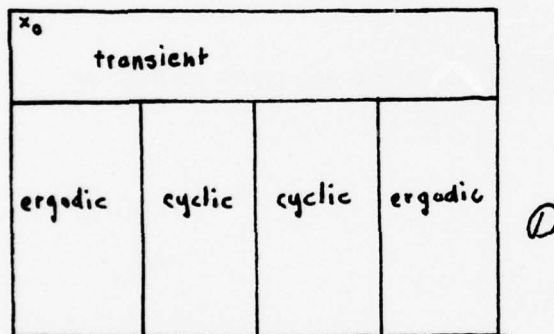

Now suppose that  $k$  is very large. Then for a typical outcome of the Markov process  $P_k$ , the state will tend to dwell long periods of time in what become unified classes in  $\bar{O}$ , with few jumps between the unified classes in  $\bar{O}$ . Let  $\{\bar{D}_1, \bar{D}_2, \dots, \bar{D}_q\} = \bar{O}$ . Then

$$\zeta(P_k) \approx \lambda_1 c_\infty(\bar{D}_1) + \lambda_2 c_\infty(\bar{D}_2) + \dots + (1 - \sum \lambda) c_\infty(\bar{D}_q)$$

for some  $0 \leq \lambda_1 + \dots + \lambda_{q-1} \leq 1$ . Let  $\bar{D}^*$  be the unified class in  $\bar{O}$  with the largest  $c_\infty(\bar{D}^*)$ . Either  $\bar{D}^*$  is reachable in  $\bar{P}$  or it isn't. If it is, take  $\bar{P}^*$  to be  $\bar{P}$ . If it isn't, make the appropriate chain of transient states nonzero (this is possible since each  $P_k \in \mathcal{P}$  and columns can be chosen independently). Then

$$\lim_{k \rightarrow \infty} \zeta(P_k) \leq \zeta(\bar{P}^*)$$

and since  $\zeta(P_k)$  are increasing,  $\bar{P}^* \in \mathcal{P}$  must be an upper bound, as a contradiction.

## 2.12 Fundamental Bounding Theorem.

Theorem. Let  $Q(\mathcal{P})$  be an ambiguous process. Then

$$J(Q) \leq \zeta(P^*)$$

Furthermore, if  $Q(\mathcal{P})$  is the ambiguous process model of some finite-state compensator, and  $J$  is the associated cost, then

$$J \leq \zeta(P^*)$$

The general proof is quite involved so we will prove the assertion

here for the special case  $\mathcal{P}$  strictly positive, i.e., all  $P \in \mathcal{P}$  strictly positive. Thus all  $P \in \mathcal{P}$  are ergodic. The general proof, accounting for the discontinuities of  $\zeta$ , can be constructed along the general lines outlined in the previous theorem on the existence of  $P^*$ .

Also, in proving this theorem, we will make one assumption on the behaviour of outcomes of the ambiguous process. Let  $\mathcal{S}$  be a stochastic process in  $\mathcal{Q}$ , let  $\Omega$  be the set of all outcomes, and let  $\omega \in \Omega$ . Denote the outcome  $\omega$  up to time  $T$  be  $\omega_T$ , and let  $x_i \in X$ . Then there must be some set of times, call them  $\{T_k\}$ , for which  $x(T) = x_i$  in the outcome  $\omega$ . This set may be empty, and it may be all  $T \in \mathbb{Z}^+$ . Now at each of these times,  $T_k$ , the probability that  $x(T_k + 1)$  will be each of  $x_1, x_2, \dots, x_N$  given  $\omega_{T_k}$  is some vector  $p_i(\omega_{T_k})$ ; thus the probability that  $x(T_k + 1)$  is some particular  $x_j$  given  $\omega_{T_k}$  is  $p_i(\omega_{T_k})(j)$ , or  $P_{\omega_{T_k}}(i, j)$  for short. Now for this particular outcome  $\omega$ , and for each  $T_k$ , either  $x(T_k + 1) = x_j$  or  $x(T_k + 1) \neq x_j$ . Let  $z_j(T_k + 1)$  be the indicator of the former, so that  $z_j(T_k + 1) = 1$  iff  $x(T_k + 1) = x_j$ . For outcomes with  $\{T_k\}$  infinite, we would expect that

$$\lim_{n \rightarrow \infty} \sum_{k=1}^n \frac{(z_j(T_k + 1) - P_{\omega_{T_k}}(i, j))}{n} \rightarrow 0$$

since the trials of  $z_j = 1$  have been in some sense "independent", and all have uniformly bounded variance. If  $\omega$  has this property, we call it well-tempered. In our proof, we restrict our attention to well-tempered outcomes. Proving that the well-tempered outcomes have probability one is beyond the scope of this research.

Before turning to the proof of the bounding theorem, we will show by counterexamples that each property of the set  $\mathcal{P}$  plays a non-trivial role.

Counterexample 1. Non-closed ambiguous process. It is clear that  $P^*$  may not exist if  $\mathcal{P}$  is not closed. In this counterexample we show that  $P^*$  can exist, but  $\zeta(P^*)$  is still not a lower bound on expected return.

$$\text{Let } \mathcal{P}_1 = \left\{ \begin{pmatrix} x \\ y \end{pmatrix} : x \in \left[\frac{1}{4}, 1\right), y = 1-x \right\}$$

$$\mathcal{P}_2 = \left\{ \begin{pmatrix} 0 \\ 1 \end{pmatrix} \right\}$$

$$c(\pi_1) = 0, c(\pi_2) = 1.$$

Clearly the limiting partition, for all  $P \in \mathcal{P}$ ,

is  $\{\{\pi_2\}\}$ , and  $c_\infty\{\pi_2\} = 1$ . Thus take as  $P^*$  any element of  $\mathcal{P}$  so  $\zeta(P^*) = 1$ .

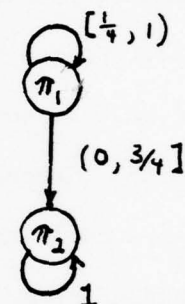

Now consider the following realization.

$$P(T) = \begin{pmatrix} e^{-2^{-T}} & 0 \\ 1 - e^{-2^{-T}} & 1 \end{pmatrix}, T=0, 1, \dots$$

The probability that this Markov process, when started in state  $\pi_1$ , will stay in  $\pi_1$  forever is

$$\prod_{T=0}^{\infty} e^{-2^{-T}} = e^{-\sum_{T=0}^{\infty} 2^{-T}} = e^{-2} > 0$$

so there is a probability of  $e^{-2}$  that

$$1 = \zeta(P^*) > \liminf_{T \rightarrow \infty} \frac{1}{T} \sum_{t=1}^T c(x(t)) = 0, \text{ so } (P^*) \text{ is not a lower}$$

bound.

Counterexample 2. Non-Independent Columns. The independence of columns in  $\mathcal{P}$  is crucial, as we shall illustrate. Consider  $P_1$  and  $P_2$  below and let  $\mathcal{P} = \text{cvxhull}\{P_1, P_2\}$ , and let

$$c(\pi) = \begin{cases} 0 & \text{if } \pi = \pi_1 \\ 1 & \text{otherwise} \end{cases}$$

and  $\pi_1$  the initial state. It is clear that  $\zeta(P_1) = \zeta(P_2) = \frac{2}{3}$ . Let  $P \in \mathcal{P}$  be arbitrary, so

$$P = \lambda P_1 + (1-\lambda)P_2, \quad \lambda \in [0,1]$$

Suppose  $x(T) = \pi_1$ . Then in a finite number of steps,  $x$  will return to  $\pi_1$ . The three possibilities and their probabilities with transition matrix  $P$  are shown below.

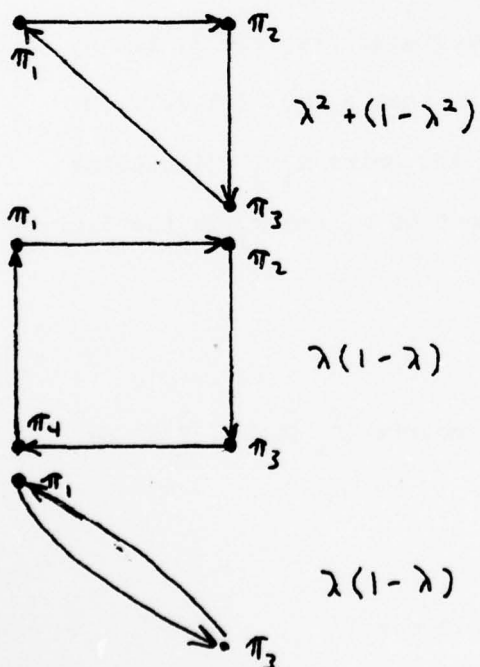

We can now compute  $\zeta(P)$ ; it is:

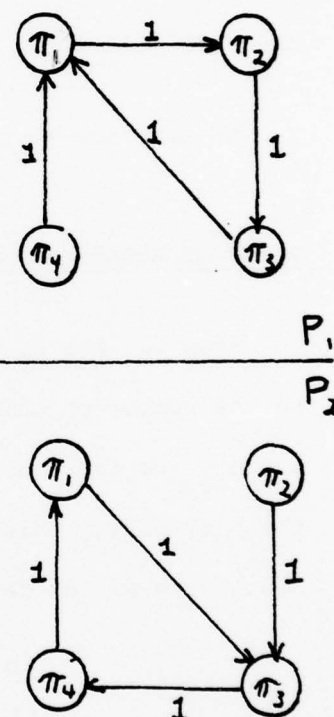

$$\frac{2(\lambda^2 + (1-\lambda)^2) + \lambda(1-\lambda) + (3)\lambda(1-\lambda)}{3(\lambda^2 + (1-\lambda)^2) + 2\lambda(1-\lambda) + 4\lambda(1-\lambda)} = \frac{2}{3}$$

Thus  $\zeta(P^*) = \frac{2}{3}$ . Now consider the following realization:

$$p(0)=P_2, p(1)=P_1, p(2)=P_2, p(3)=P_1, \dots$$

Then  $x(T)$  is deterministic,  $x(0)=\pi_1, x(1)=\pi_3, x(2)=\pi_1, \dots$  and

$$\frac{2}{3} = \zeta(P^*) > \liminf_{T \rightarrow \infty} \frac{\sum_{t=1}^T c(x(t))}{T} = \frac{1}{2}$$

and  $\zeta(P^*)$  is not a lower bound.

We turn now to the proof of the theorem.

Proof of Bounding Theorem:

Step 1. Let  $\omega_T$  be a finite string of characters from  $X$ . Let  $n_i$  be the number of character  $i$  in  $\omega_T$ , assume that  $n_i > 0 \quad i=1,2,\dots,N$ . Let  $n_{ij}$  be the number of occurrences of the pairs  $x_i x_j$  (including the possibility that  $x_i$  is the last element of  $\omega_T$  and  $x_j$  is the first.) Since  $n_i \neq 0$  we can define the vectors

$$\hat{p}_i = \frac{1}{n_i} \begin{pmatrix} n_{i1} \\ n_{i2} \\ \vdots \\ n_{iN} \end{pmatrix}. \quad \text{Let } \hat{P} \text{ be the matrix } (\hat{P}_1 \hat{P}_2 \dots \hat{P}_N). \text{ We}$$

claim that  $\hat{P}p = p$  has a solution  $p$  with  $u^T p = 1$ .

Example. Let  $\omega_T = 1 1 3 2 3 1 1 3 1 1 2 3 1 3 3 1$ . Then  $n_1=8, n_2=2, n_3=6$ . Write  $n_{ij}$  into a matrix:

$$(n_{ij}) = \begin{pmatrix} 4 & 0 & 4 \\ 1 & 0 & 1 \\ 3 & 2 & 1 \end{pmatrix}, \text{ and then } \hat{P} = \begin{pmatrix} \frac{1}{2} & 0 & \frac{2}{3} \\ \frac{1}{8} & 0 & \frac{1}{6} \\ \frac{3}{8} & 1 & \frac{1}{6} \end{pmatrix}$$

Now notice that just given  $\hat{P}$  and the length of  $\omega_T$  (i.e., 16),  $n_1$ ,  $n_2$  and  $n_3$  can be determined. Moreover,  $\frac{n_1}{16}$ ,  $\frac{n_2}{16}$ ,  $\frac{n_3}{16}$  can be determined just from  $\hat{P}$ . This is because

$$\hat{P} \begin{pmatrix} n_1 \\ n_2 \\ n_3 \end{pmatrix} = \begin{pmatrix} n_1 \\ n_2 \\ n_3 \end{pmatrix}, \quad n_1 + n_2 + n_3 = 16$$

can be solved for  $n_1$ ,  $n_2$  and  $n_3$  uniquely.

Proof: Follows because  $\hat{P}$  is an ergodic stochastic matrix (see Section 2.9)

The significance of this observation is the following. Let

$$\zeta_T = \sum_{t=1}^T \frac{r(x(t))}{T}$$

Then  $\zeta_T$  is a function of  $\hat{P}$ , in fact  $\zeta_T = \zeta(\hat{P})$ . What we will do next is show that  $\hat{P} \rightarrow P \in \mathcal{P}$  as  $T \rightarrow \infty$ .

Step 2. Let  $\mathcal{Q}$  be a stochastic process in  $\mathcal{A}$ , and let  $\omega$  be a well-tempered outcome. Let  $z_i(t)$  be the indicator of  $x_i$  as discussed earlier. Then for  $\omega$ , and all  $i=1,2,\dots,N$ ,

$$\sum_{t=0}^{\infty} z_i(t) = \infty$$

Proof: Let  $D$  be the set of  $i$  for which the sum does not go to infinity, i.e., for which the sum is bounded above. Now since each  $z_i(t)$  is either one or zero, there must be some  $T_i$  for each  $i \in D$  such that  $z_i(t) = 0$  when  $t > T_i$ . Let  $T$  be the largest of  $T_i$ .

Let  $d \in D$ . For every  $P \in \mathcal{P}$ , there is a strictly positive probability  $P(i,d)$  for each  $i$ . Let  $i \notin D$  be fixed. Since  $\mathcal{P}$  is compact, there must be some strictly positive minimum for  $P(i,d)$  over  $\mathcal{P}$ , call it  $p$ . Now

$$\lim_{n \rightarrow \infty} \sum_{\substack{z_i(T_k)=1 \\ T_k > T \\ k \leq n}} \frac{z_d(T_k) - P_{\omega}(i,d)}{n} \leq \sum_{\substack{z_i(T_k)=1 \\ T_k > T \\ k \leq n}} \frac{z_d(T_k) - p}{n}$$

$$\lim_{n \rightarrow \infty} \sum \frac{-p}{n} = -p \quad \text{since } z_d = 0 \text{ for } T_k > T. \quad \text{So clearly we}$$

have a contradiction as the above limit is required to go to zero for any well-tempered outcome .

Step 3. Let  $|\Delta|$  be the absolute value of the largest element in  $\Delta$ . By  $|\mathcal{P} - P|$  we mean

$$\inf_{P' \in \mathcal{P}} |P' - P|$$

which will be zero iff  $\hat{P} \in \mathcal{P}$ , since  $\mathcal{P}$  is compact. We want to prove that if  $P$  is close enough to  $\mathcal{P}$  in

this sense, then  $\zeta(\hat{P})$  will be close to  $\zeta(P)$  for some  $P \in \mathcal{P}$ .

Specifically, let  $\epsilon > 0$ . Then there exists a  $\delta$  such that for any

$$|\hat{P} - P| < \delta,$$

$$\zeta(\hat{P}) \leq \zeta(P^*) + \epsilon$$

Proof: Since  $\mathcal{P}$  is compact and  $\zeta$  is differentiable everywhere on  $\mathcal{P}$ ,  $\zeta$  is uniformly continuous in a neighborhood of  $P$ , call it  $\delta_1$ . Choose  $\delta < \delta_1$  so that  $|\hat{P} - P| < \delta \rightarrow |\zeta(\hat{P}) - \zeta(P)| < \epsilon$  for all  $P \in \mathcal{P}$ . Then certainly, since  $\zeta(P^*)$  lower bounds  $\zeta$  on  $\mathcal{P}$ , the above equation must hold.

#### Step 4. Final Proof.

Let  $\mathcal{Z}$  be a stochastic process in  $\mathcal{A}$ ,  $\omega \in \Omega$  a well-tempered outcome of  $\mathcal{Z}$ . Choose  $\epsilon > 0$ . Choose  $T$  large enough that  $P$  is within  $\delta$  of for the appropriate  $\delta$  in Step 3; this is possible since there are only a finite number of characters  $x_i$ , and for each,

$$\lim_{T_k \rightarrow \infty} \frac{1}{n} \left[ \begin{pmatrix} \sum z_1(T_k) \\ \sum z_2(T_k) \\ \vdots \\ \sum z_N(T_k) \end{pmatrix} - \sum p_i(\omega_{T_k}) \right] \rightarrow 0$$

so that for  $\hat{P} = \frac{1}{n} \begin{pmatrix} \sum z_1(T_k) \\ \vdots \\ \sum z_N(T_k) \end{pmatrix}$ ,  $|\hat{P} - P| < \delta$ , for  $T$  large enough.

$$\text{Since } \limsup_{T \rightarrow \infty} \frac{1}{T} \sum_{n=1}^T r(x(t)) = \limsup_{T \rightarrow \infty} \zeta_T = \limsup_{T \rightarrow \infty} \zeta(\hat{P})$$

and for  $T$  large enough,  $\zeta(P) \leq \zeta(P^*) + \epsilon$ , we conclude that

$$\limsup_{T \rightarrow \infty} \zeta(\hat{P}) \leq \limsup_{T \rightarrow \infty} (\zeta(P^*) + \epsilon(T)) = \zeta(P^*)$$

The second part of the theorem is a direct consequence of the argument in 2.7.

## CHAPTER III

## 3.1 Balancing an Inverted Pendulum

In the previous Chapter, ambiguous processes were defined for a given plant and compensator by means of a conceptualization  $\Pi$  and transition bound  $F$ . In this Chapter we will solidify the ideas presented so far by bounding the performance of a multi-state compensator for an inverted pendulum. This example will also serve as a vehicle for introducing simplex measure spaces, a special kind of ambiguous measure space on which the transition bound  $F$  is easily defined. We will formulate the inverted pendulum first as a deterministic system, analyze its performance, and then introduce uncertainty modeled in a simplex measure space and show that this uncertain plant can be analyzed using exactly the same methods as the deterministic case. The analysis of probabilistic uncertainty, would, clearly be much more difficult, strengthening our claims on the utility of ambiguous measure spaces as models of uncertainty.

Consider the inverted pendulum with a torque applying actuator illustrated in Figure (3.1). Let  $\theta(T), \dot{\theta}(T), u(T), m$  and  $l$  be the pendulum angle, angular velocity, control torque, mass and length respectively. The linearized differential equation for this system is then:

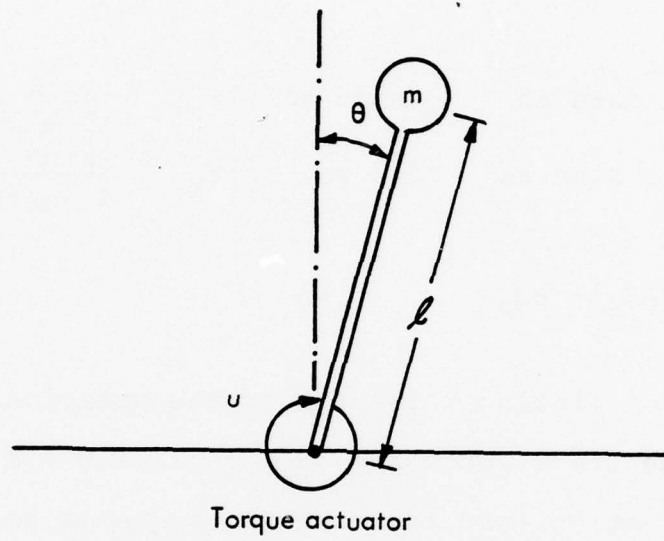

Figure 3.1.

$$\frac{d}{dt} \begin{pmatrix} \theta \\ \dot{\theta} \end{pmatrix} = \begin{pmatrix} 0 & 1 \\ g/l & 0 \end{pmatrix} \begin{pmatrix} \theta \\ \dot{\theta} \end{pmatrix} + \begin{pmatrix} 0 \\ 1/ml^2 \end{pmatrix} U$$

From this we calculate the discrete time transition equation, with time interval  $\Delta$ :

$$\begin{pmatrix} \theta_{k+1} \\ \dot{\theta}_{k+1} \end{pmatrix} = \begin{pmatrix} \cosh a\Delta & \frac{1}{a} \sinh a\Delta \\ a \sinh a\Delta & \cosh a\Delta \end{pmatrix} \begin{pmatrix} \theta_k \\ \dot{\theta}_k \end{pmatrix} + \begin{pmatrix} \frac{\cosh a\Delta - 1}{ml^2 a} \\ \frac{\sinh a\Delta}{ml^2 a} \end{pmatrix} U_k$$

$$\text{or } X_{k+1} = AX_k + BU_k$$

where  $a = \sqrt{g/l}$ . Relating this back to the notation of Section 2.3, we take the state space  $X = \mathbb{R}^2$ ,  $f : X \times U \rightarrow X$  as given in the above equation, and the control torque is restricted to the range  $-5$  to  $5 \text{ kgm}^2/5^2$ , so  $U = [-5, 5]$ .

The control system for this pendulum is very simple. there are sensors for both  $\theta$  and  $\dot{\theta}$ , but the only processing which is performed on these two sensor voltages is to compare each one with two pre-selected levels, as shown in Figure (3.2).

Letting  $-\theta_1$  and  $\theta_1$  be the threshold levels for  $\theta$ , and  $-\dot{\theta}_2$  and  $\dot{\theta}_2$  be the threshold levels for  $\dot{\theta}$ , we see that there are only nine possible outputs from this coder, call them  $Y = \{y_1, \dots, y_9\}$ , where, for example,  $y_4$  might correspond to:

$$y_4 \Leftrightarrow \begin{pmatrix} \theta \in (-\infty, -\theta_1) \\ \dot{\theta} \in (-\dot{\theta}_2, \dot{\theta}_2) \end{pmatrix}$$

Thus we have a coder and the mapping  $C: X \rightarrow Y$  is shown diagrammatically in Figure (3.3). The actual values of the

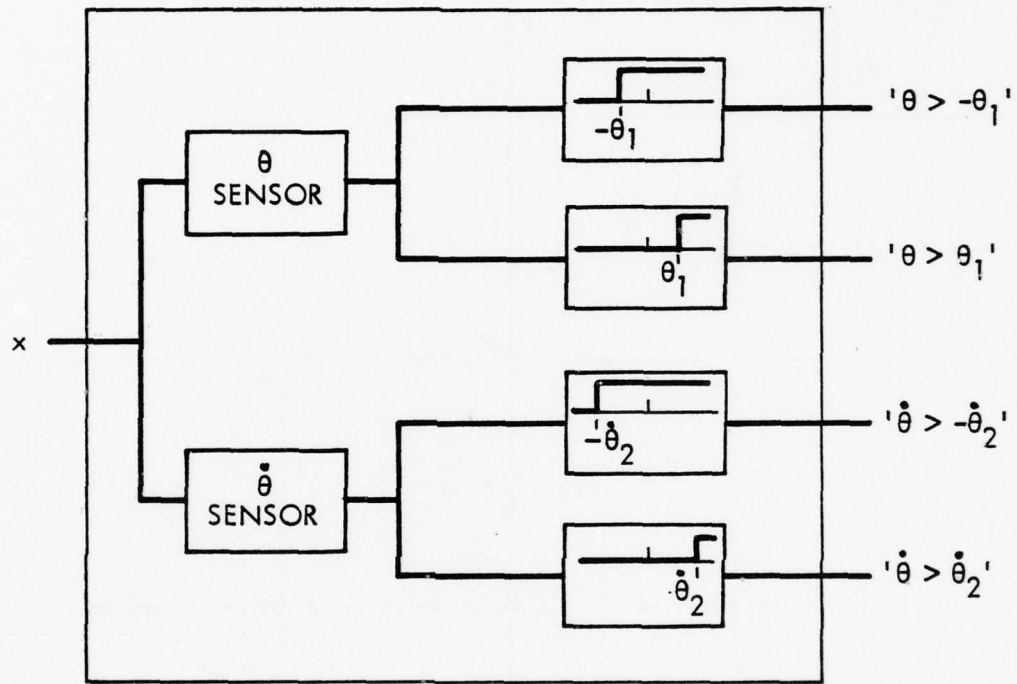

Figure 3.2.

AD-A062 796

MASSACHUSETTS INST OF TECH CAMBRIDGE LAB FOR INFORMA--ETC F/G 12/1  
FINITE-STATE CONTROL OF UNCERTAIN SYSTEMS.(U)

SEP 78 S N JONES  
LIDS-TH-853

AFOSR-77-3281

AFOSR-TR-78-1515

NL

UNCLASSIFIED

2 OF 2

AD A0627



END  
DATE  
FILMED  
5-79  
DDC

0627

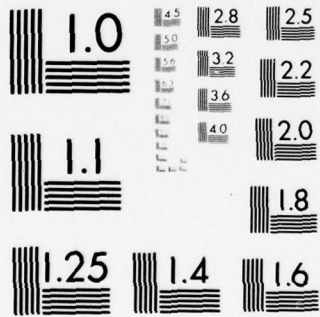
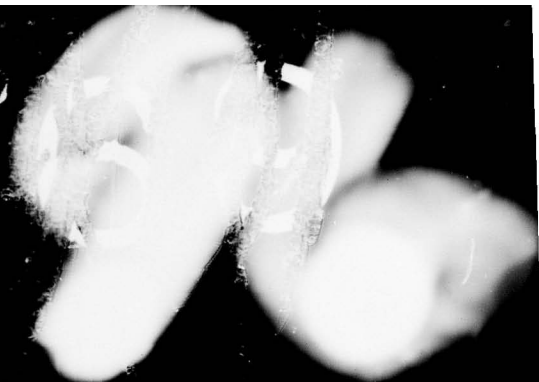

MICROCOPY RESOLUTION TEST CHART  
NATIONAL BUREAU OF STANDARDS-1963-A

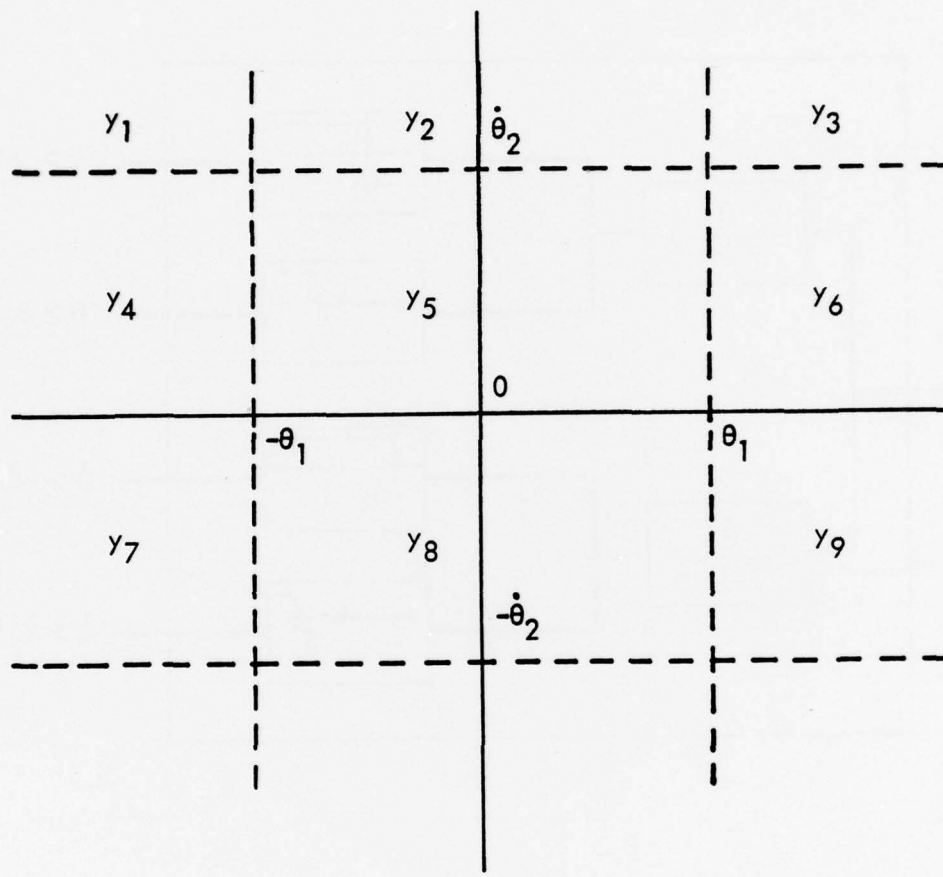

Figure 3.3.

thresholds are also shown.

The compensator has six states, so let  $Z = \{z_1, \dots, z_6\}$ . The state transition mapping and readout map of the compensator are diagrammed in Figure (3.4). To complete the description of the closed-loop system, the initial state of the pendulum,  $x(0)$ , is known to lie in  $C^{-1}(y_5)$ , and  $z(0) = z_1$ . In our previous terminology, we have  $\eta_0 = \xi_C^2 - 1(s)$ . The performance index or cost associated with this compensated system,  $J$ , is defined by

$$R(x) \triangleq \theta^2 + \dot{\theta}^2 \quad (\text{See sect. 2.7.})$$

To arrive at good bounds on  $J$  we must find an appropriate conceptualization  $\Pi$  and transition bound  $F$ . We concentrate first on finding a suitable  $\Pi$ .

The smallest  $\Pi$  is just the set  $Y \times Z$ ; so we will try first the conceptualism

$$\Pi_1 = Y \times Z$$

and see what kinds of transition bounds result. Consider  $(\frac{y}{2}) \in \Pi$ . If  $y \neq y_5$ , then

$$r(y) = \sup_x \{R(x) \mid x \in C^{-1}(y)\} = \infty$$

This means that the upper bound on  $J$  will be  $\infty$  if  $x(t)$  even steps once outside of area 5. In fact,  $x(1)$  could be outside area 5 with probability one; consider  $\mu_1 = \delta \begin{pmatrix} .09 \\ .20 \end{pmatrix}$ , which is certainly in  $\eta_0 = \xi_C^2 - 1(s)$ , but then  $\mu_1 = \delta \begin{pmatrix} .11 \\ .3 \end{pmatrix}$ , which is in  $C^{-1}(y_3)$  with probability one. On the basis of this information

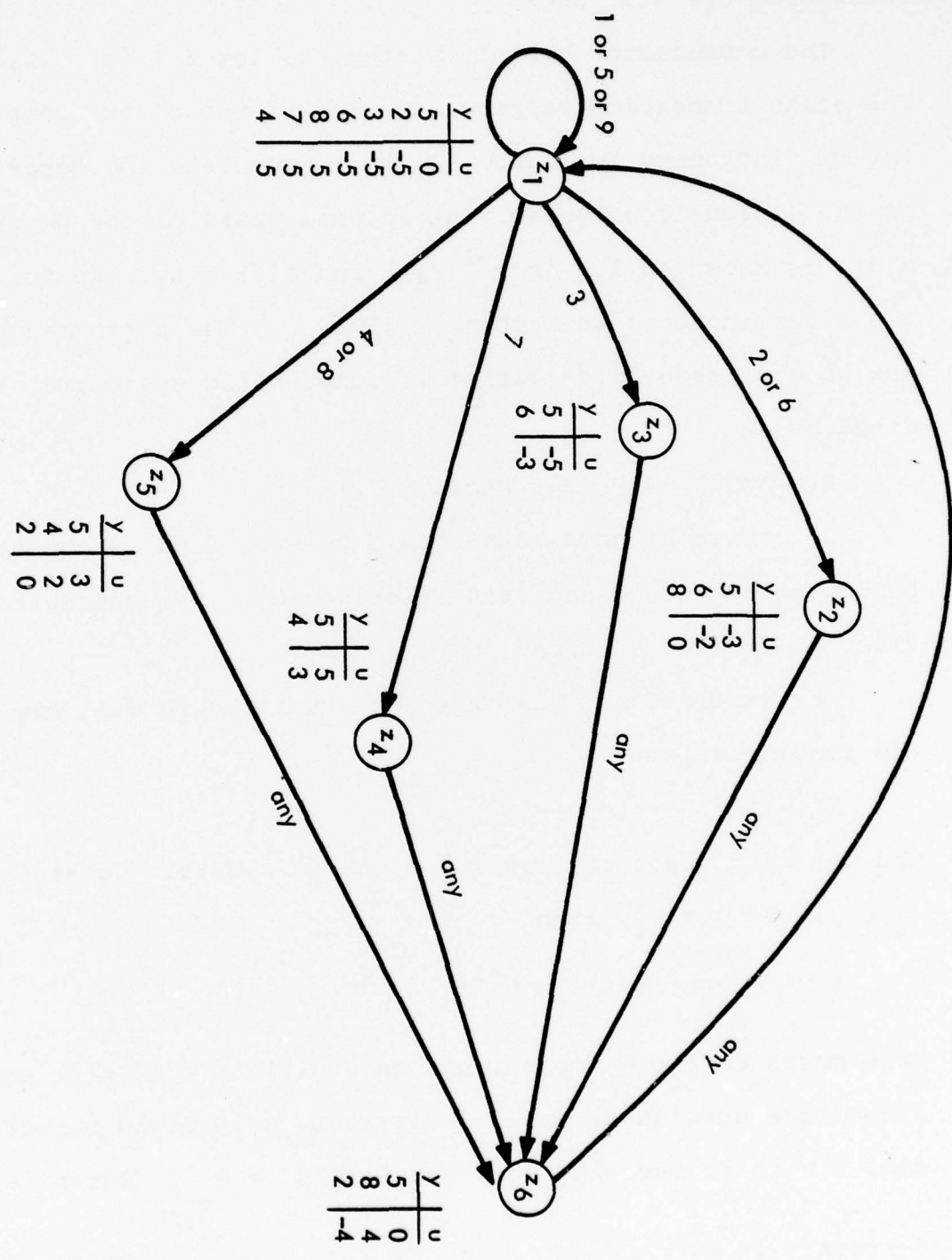

Figure 3.4.

we can conclude that either  $\Pi_1$  is not a very good conceptualization for deriving bounds, or that the pendulum is not stabilized and  $J = \infty$ . We investigate further with a more sophisticated  $\Pi$ ; clearly the question is how to augment  $\Pi$  sensibly.

To do this we will compute some "typical" histories of the closed loop system, starting from a "stabilized" position, through an unstable period when corrective control is applied, and hopefully back once again to a "stabilized" position within the bounds in which the sequence began. An obvious candidate for a "stable" area of  $X$  is  $C^{-1}(s)$ , since it is the only area with bounded cost. Looking over the compensator stable space, we see that in states  $z_1$  and  $z_6$ , no corrective control is applied when  $Cx = y_5$ , so we could take either of these to be the corresponding "stable" state in the compensator; we choose  $z_3$ . Then we now wish to examine "typical" histories which began in the "stable" closed-loop state  $\begin{pmatrix} y_5 \\ z_1 \end{pmatrix}$ .

Notice that  $C^{-1}(s)$  is convex, so if  $C(x(T)) = y_5$ , then

$$x(T) \in \text{cvx} \left\{ \begin{pmatrix} .1 \\ .3 \end{pmatrix}, \begin{pmatrix} .1 \\ -.3 \end{pmatrix}, \begin{pmatrix} -.1 \\ -.3 \end{pmatrix}, \begin{pmatrix} -.1 \\ .3 \end{pmatrix} \right\}$$

If also  $\ddot{u}(T) = 0$ , then  $x(T+1)$  must also lie in a convex region  $X$ , since  $f$  is a linear map. In fact,

$$(T)+1 \in \text{cvx} \left\{ A \begin{pmatrix} .1 \\ .3 \end{pmatrix}, A \begin{pmatrix} .1 \\ -.3 \end{pmatrix}, A \begin{pmatrix} -.1 \\ .3 \end{pmatrix}, A \begin{pmatrix} -.1 \\ -.3 \end{pmatrix} \right\}$$

$$= \text{cvx} \left\{ \begin{bmatrix} .13 \\ .4 \end{bmatrix}, \begin{bmatrix} .07 \\ -.2 \end{bmatrix}, \begin{bmatrix} -.07 \\ .2 \end{bmatrix}, \begin{bmatrix} -.13 \\ -.4 \end{bmatrix} \right\}$$

for the particular value of A given earlier. This convex region is shown in Figure (3.5). Let us relate this back to the terminology of Chapter 2. If  $\pi_1 = \begin{bmatrix} y_5 \\ z_1 \end{bmatrix}$ , then

$$\eta_{\pi_1} = P_{C^{-1}(5)} \xi^2 = \xi^2_{C^{-1}(5)}$$

What we claim above is that

$$F_0 \eta_{\pi_1} = F_0 \xi^2_{C^{-1}(5)} = \xi^2_{AC^{-1}(5)}$$

is indeed a transition bound (where  $AC^{-1}(5)$  indicates the set of pointwise multiplications  $\{Ax; x \in C^{-1}(5)\}$ ). Earlier we called  $AC^{-1}(5)$  the infimal support of  $F_0 \eta_{\pi_1}$ . Let us postpone the discussion of whether or not F is a transition bound and get on with the computation of "typical histories".

So far we have calculated an infimal support for  $x(T+1)$  when  $\pi(T) = \pi_1$ . Evidently  $x(T+1)$  could be in several coder areas:  $y_5, y_3, y_6, y_7, y_8$ . Each of these possibilities is the beginning of a different history. If, for example,  $Cx(T+1) = y_5$ , then we have "returned" to the stable state,  $\pi$ , from which we began, and can consider this history as finished. If, however,  $C(x(T+1)) = y_6$ , for example, we have not yet returned back to the stable history  $\pi_3$ , so we note this as a possibility which must be explored further. Hence we increase our "conceptualization" of the closed-loop system by adding the history:

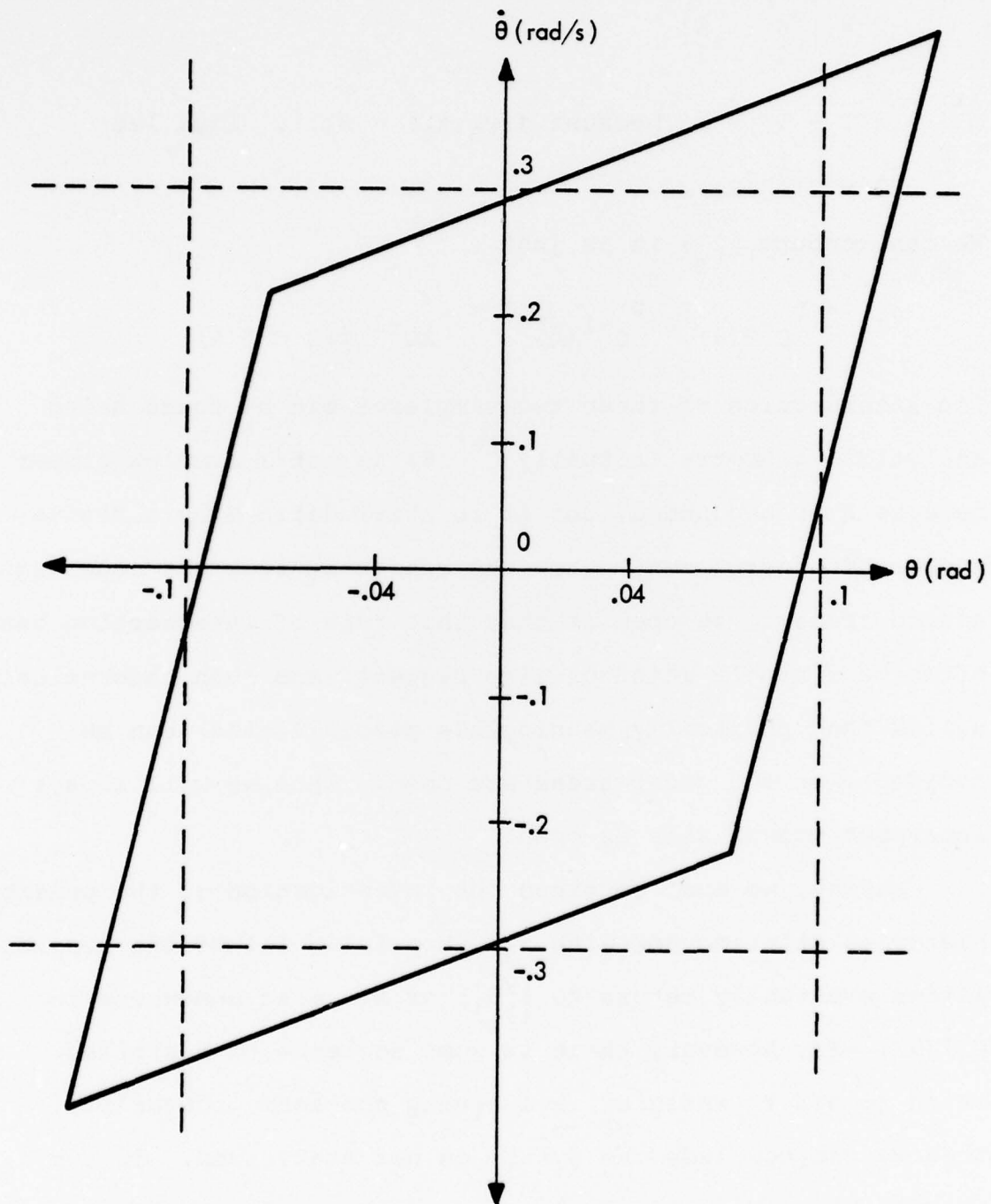

Figure 3.5.

$$\pi_2 = \begin{pmatrix} y_6 \\ z_1 \end{pmatrix} \begin{pmatrix} y_5 \\ z_1 \end{pmatrix}$$

( $z(T+1) = z_1$  because  $\tau(y_5, z_1) = z_3$ .) Thus let

$$\Pi_2 = \Pi_1 \cup \pi_2$$

We can compute  $\eta_{\pi_2}$ ; it is just

$$\eta_{\pi_2} = P_{C^{-1}(6)} F_0 P_{C^{-1}(5)} \xi^2 = \xi^2_{AC^{-1}(5)\Omega C^{-1}(6)}$$

The intersection of these two simplexes can be found using analytical geometry (actually  $C^{-1}(6)$  is not a simplex proper because  $A$  is unbounded, but it is still defined by a finite number of hyperplanes.) Now the reason we took the coder equivalence areas to be open is that this type of intersection can often be a single point or line segment, and such theoretical uglies (and physically meaningless possibilities) can be avoided when the coder areas are open. Thus we will always interpret convex sets as open.

Anyway, we must continue our investigation of the possible histories starting now with  $\pi_2$ . Hopefully all of the possibilities eventually return to  $\begin{pmatrix} y_5 \\ z_1 \end{pmatrix}$ , or at least somewhere in  $C^{-1}(5)$ . If, however, there is some sequence of histories which go off to infinity, all having non-zero probability, then we can conclude the system is not stabilized. In our example here this doesn't happen (as the reader would expect), and all histories do indeed settle right back down into  $\begin{pmatrix} y_5 \\ z_1 \end{pmatrix}$ . Let us take  $(\pi_1, \pi_2)$  a step further:

$$\begin{aligned}
 x(T+2) \in F_{\sigma(y_6, z_1)} \eta_{\pi_2} &= F_{-5} \xi^2 AC^{-1}(5) \Lambda C^{-1}(6) \\
 &= \xi^2 A(AC^{-1}(5) \Lambda C^{-1}(6)) - 5B
 \end{aligned}$$

Note that all of our histories begin in  $\begin{pmatrix} y_5 \\ z_1 \end{pmatrix}$ , so it is really unnecessary to write each compensator state in the history, i.e.,

$$\begin{pmatrix} y_5 \\ z_1 \end{pmatrix}, \begin{pmatrix} y_6 \\ z_1 \end{pmatrix} \begin{pmatrix} y_5 \\ z_1 \end{pmatrix}, \begin{pmatrix} y_5 \\ z_2 \end{pmatrix} \begin{pmatrix} y_6 \\ z_1 \end{pmatrix} \begin{pmatrix} y_5 \\ z_1 \end{pmatrix}$$

could be written, with no loss, as

$$(5), (65), (565)$$

since the successive  $z(T)$ 's can be computed with  $\tau$ . Thus a next history in our sequence might be

$$\eta_{(565)} = \xi^2 ((A(AC^{-1}(5) \Lambda C^{-1}(6)) - 5B) \Lambda C^{-1}(5)) - 3B$$

which is very explicit, to demonstrate that the  $\eta$ 's are in fact finitely computable and representable quantities. We won't write any more out, but show the convex regions with pictures. Our typical sequence, starting and ending in  $\begin{pmatrix} y_5 \\ z_1 \end{pmatrix}$ , is shown in Figure (3.6). Since every  $\eta$  is a collection of measures, this means that

$$\eta_{(55565)} \subset \eta_{(5)}$$

and

$$z_{(55565)} = z_{(5)} = z_1$$

Another such sequence is  $\{(5), (25), (525), (5525), (55525)\}$ . This is illustrated in Figure (3.7).

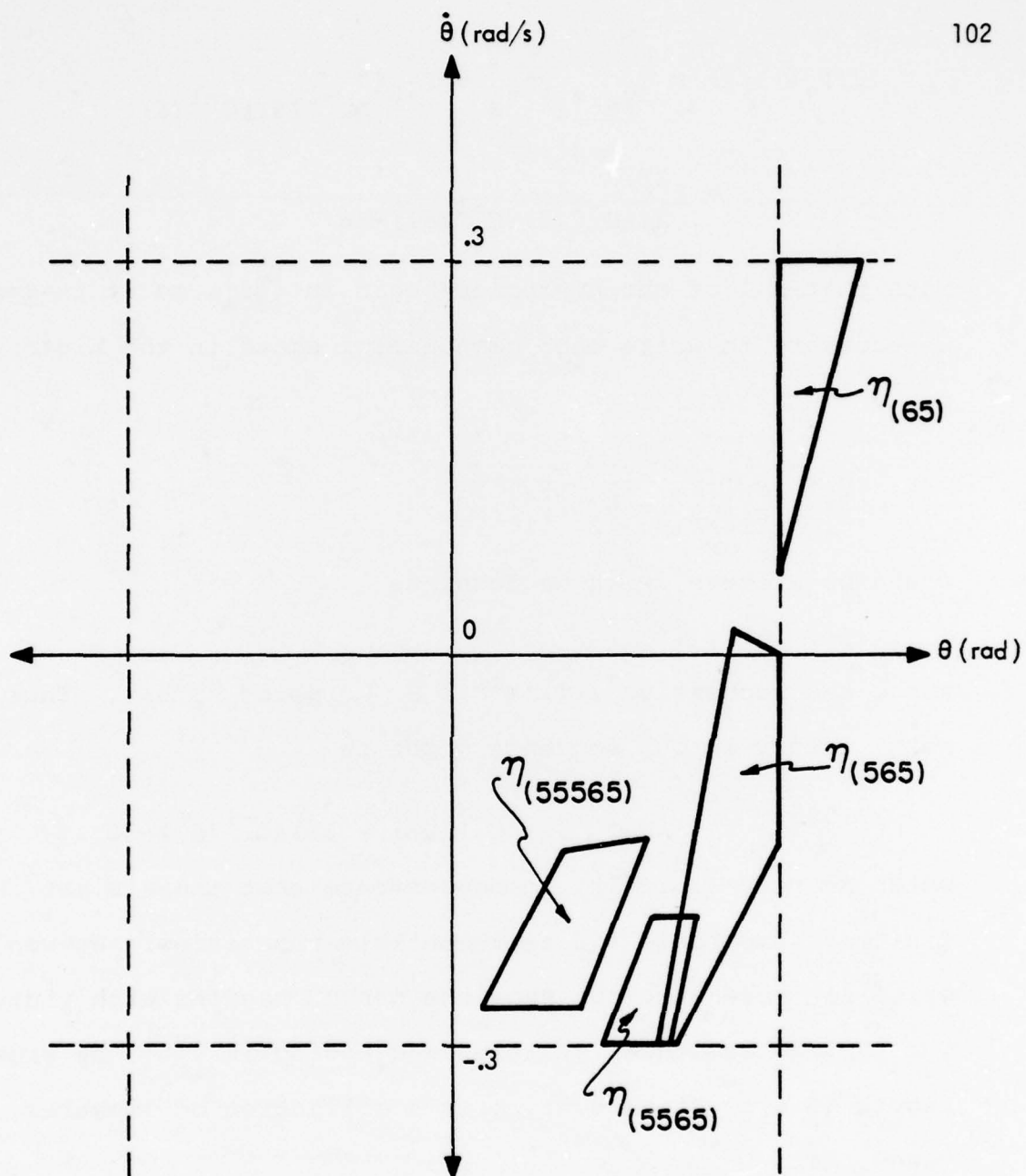

Figure 3.6.

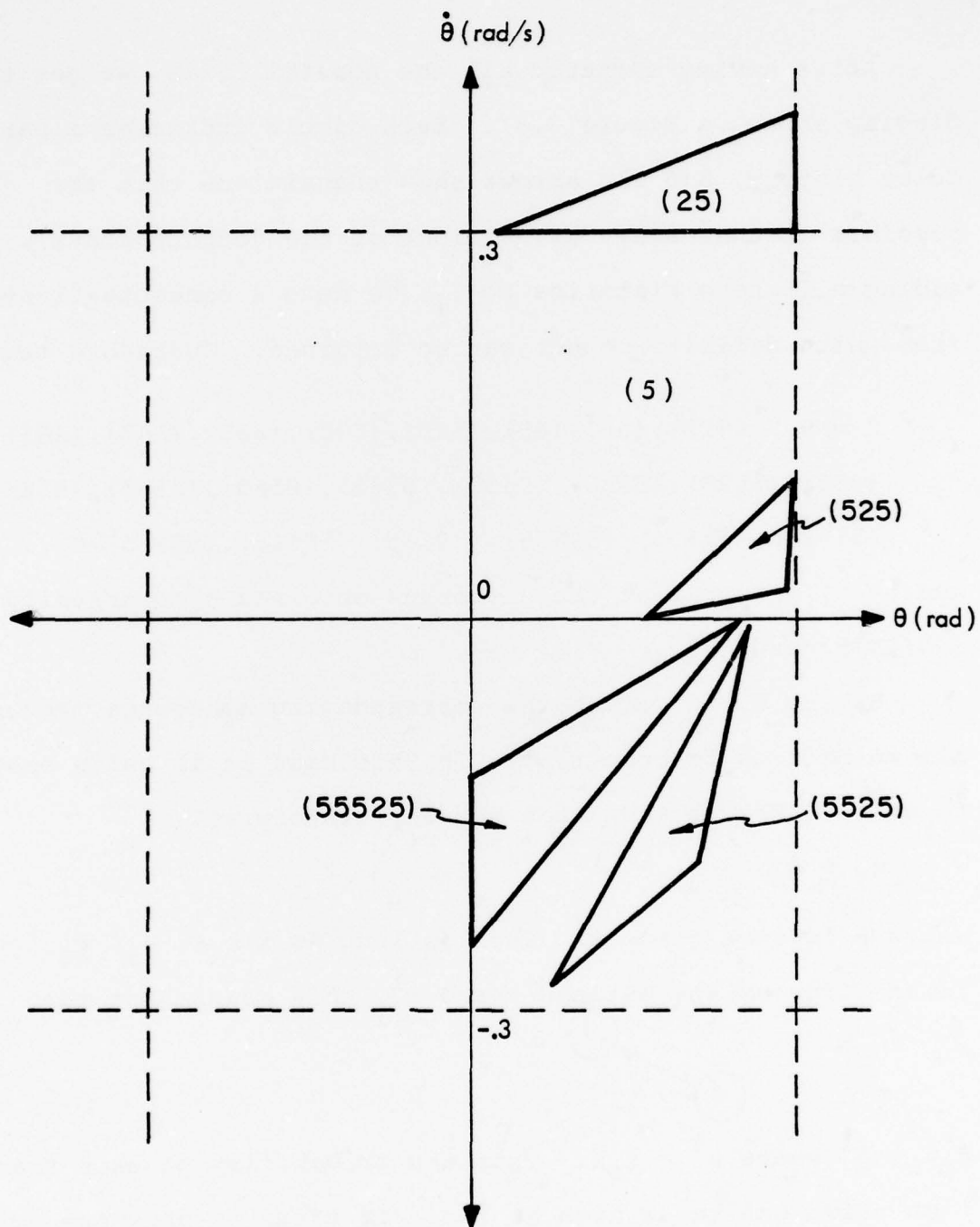

Figure 3.7.

After having computed all the possibilities, we get the diagram shown in Figure(3.8). Each circle indicates a particular history, and the arrows show transitions that are possible (technically, transitions of the journal state). By adding all these histories to  $\Pi_1$ , we have a conceptualization from which definite bounds can be obtained. Therefore take

$$\Pi = \Pi_1 \cup \{(25), (35), (65), (525), (535), (635), (565), (665), (865), (5525), (5535), (5635), (5565), (8565), (5665), (5865), (55525), (55535), (55635), (58565), (55665), (55865)\} \cup \{\dots\}$$

where  $\{\dots\}$  represent the histories obtained symmetrically from (45), (75) and (85).

Having  $\Pi$ , to define the corresponding ambiguous process all we need is to compute  $\rho$ . In this case it is quite easy to do so. For we know that for any history  $\pi \in \Pi$ ,

$$\eta_\pi = \xi_S$$

where  $S$  is some simplex. Thus as long as  $x \in S$ ,  $\delta_x \in \xi_S$ , and if an arrow exists between  $\pi$  and  $\pi^1$ , this means just that

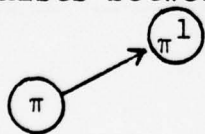

$F_u \delta_x \in S^1$  where  $\pi^1 = \xi_S^1$ . Thus the probability of each transition shown can be as high as one. If there is only one arrow leaving  $\pi$ , then the probability of this transition must be one. Otherwise each probability could be anywhere between zero or one. A typical  $P_i$  would look either like this:

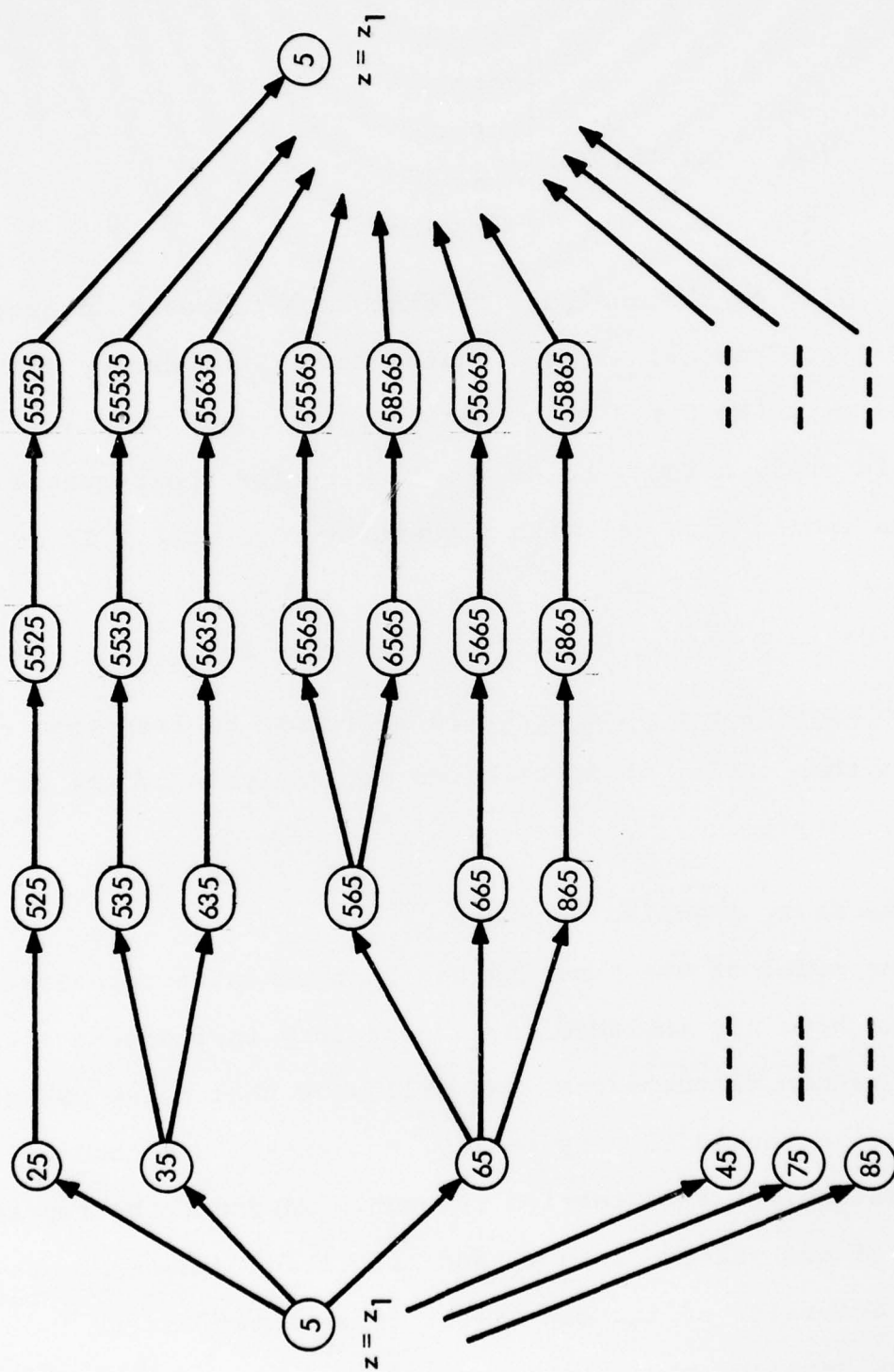

Figure 3.8.

$$\begin{pmatrix} 0 \\ \vdots \\ 0 \\ 1 \\ 0 \\ \vdots \\ 0 \end{pmatrix} \quad \text{or this:} \quad \begin{pmatrix} 0 \\ [0,1] \\ \vdots \\ 0 \\ [0,1] \\ 0 \\ \vdots \end{pmatrix}$$

Relying on the analysis of ambiguous processes presented in the last Chapter, we know that  $J$  can be bounded by choosing an extreme point  $P \in P$  such that  $\xi(P)$  is just a matrix with a "one" in every column, so we are looking for the sequence starting and ending with (s) with highest average cost. It is shown in Figure (3.9). Thus

$$\xi(P^*) = \frac{1}{s} \left[ r(\pi_{(5)}) + r(\pi_{(25)}) + \dots + r(\pi_{(58525)}) \right] = .007$$

and the root-mean-square error in  $x(T)$  must be less than  $\sqrt{J}$ , or less than .085. This completes our analysis of the deterministic system.

### 3.2 The Noisy Inverted Pendulum

Our model of the pendulum has been somewhat unrealistic because we have not included any uncertainty in its behaviour due to random disturbances. We will show that noise can be included in the model very easily, and that our method of analysis can still be carried through. In fact, the representation of the measure sets  $\eta_\pi$  and transition ranges  $P_i$  are a direct extension of the convex-set representations of the previous section, when the noise model  $\eta_u$  is a simplex measure set.

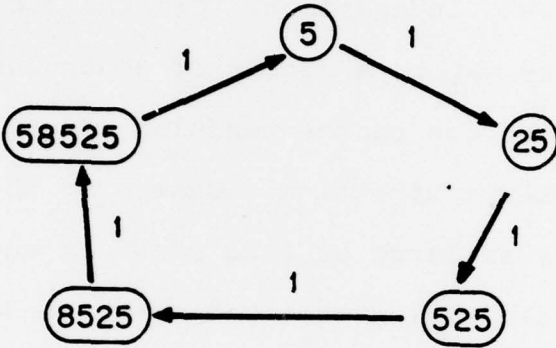

Figure 3.9.

Suppose our hypothetical inverted pendulum were out-of-doors, subjected to random breezes and gusts. For simplicity assume that the magnitude and direction of these gusts change fast enough so that the disturbances over each period of time  $(0, \Delta), [\Delta, 2\Delta), \dots$  are independent. Breezes are more common than gusts, let us say by a factor of about 100. A typical breeze applies a torque on the pendulum of no larger than  $.2 \text{ Kg m}^2/\text{s}^2$  with unknown direction. Gusts, on the other hand, can apply torques as large as  $1 \text{ Kg m}^2/\text{s}^2$  in any direction. Symbolically we are saying that  $V(T)$ , the random torque applied between  $T\Delta$  and  $(T+1)\Delta$ , has measure in  $\xi_{(-.2, .2)}$  ninety-nine percent of the time, and in  $\xi_{(-1, 1)}$  one percent of the time. Of course this is equivalent to saying that the measure of  $V(T)$  is  $.01$  times some measure in  $\xi_{(-1, 1)}$  plus  $.99$  times some measure in  $\xi_{(-.2, .2)}$ . This is an example of a simplex measure set.

Let us adopt a standard notation for simplex measure sets. The three simplexes in  $\mathbb{R}$  in question are:

$$s_1 = [-1, -.2], s_2 = [-.2, .2], [.2, 1].$$

Making additional assumption that a gust is equally likely in either direction we write

$$\eta_v = .005\xi_{s_1} + .99\xi_{s_2} + .005\xi_{s_2}$$

(In our original description  $\xi_{s_1}$  and  $\xi_{s_2}$  would not have had definite weights, and although this can certainly be represented in a more general notation, we choose to keep this discussion

as simple as possible. Also, we could have taken

$$\eta_v = .01\xi_{s_1} + .99\xi_{s_2}, \text{ but then } s_1 \text{ us } s_2 \text{ is not a simplex}$$

(and not convex).)

Let  $\pi_1 = \begin{pmatrix} y_6 \\ z_1 \end{pmatrix} \begin{pmatrix} y_5 \\ z_1 \end{pmatrix}$  as before, and let us calculate  $\eta_{\pi_1}$ , and  $P_1$ . Since

$$\eta_{\pi_1} = P_{C^{-1}(6)} F_0 P_{C^{-1}(5)} \xi$$

Let us look at:

$$F_0 \xi_{C^{-1}(5)}$$

From the description above, we have that

$$f(x, u, v) = Ax + Bu + Bv$$

since  $v(T)$  is just an additive torque. What we require of  $F$  (from section 2.6) is that:

$$F_0 \xi_{C^{-1}(s)} \supset \{ \mu : \mu = F_0(\mu^1, \lambda(T)), \mu^1 \in \xi_{C^{-1}(5)}, \lambda(T) \in \eta_v \}$$

Now  $F_0(\mu^1, \lambda(T))$  is the measure of  $Ax + Bv$  when the measure of  $x$  is  $\mu^1$  and the measure of  $v$  is  $\lambda(T)$ . Since  $\mu^1 \in \xi_{C^{-1}(5)}$ , the measure of  $Ax$  must be in  $\xi_{AC^{-1}(5)}$ . Since  $\lambda(T) \in \eta_v$ , then

the measure of  $Bv$  must be in

$$.005\xi_{Bs_1} + .99\xi_{Bs_2} + .005\xi_{Bs_3}$$

We ask that the reader check again that there is no B.S. in this equation.

Since the choice of  $\mu^1$  and  $\lambda(T)$  are independent, the above set must be equal to

$$\xi_{AC^{-1}(5)} * (.005\xi_{Bs_1} + .99\xi_{Bs_2} + .005\xi_{Bs_3})$$

In the deterministic case, we reasoned that  $\xi_A * \xi_B \supset \xi_{A+B}$  because the infimal support of any measure in  $\xi_A * \xi_B$  must be in  $A+B$ , and this idea can be extended here. Let  $\mu_1, \mu_2, \mu_3$  be measured in  $\xi_{Bs_1}, \dots, \xi_{Bs_3}$ . Then certainly

$$\xi_{C^{-1}(5)} * (.005\mu_1 + .99\mu_2 + .005\mu_3) = .005\xi_{C^{-1}(5)}^{\mu_1} + .99\xi_{C^{-1}(5)}^{\mu_2} + .005\xi_{C^{-1}(5)}^{\mu_3}$$

since convolution is linear, and from our previous reasoning we have

$$\xi_{AC^{-1}(5)}^{\mu_1} \in \xi_{AC^{-1}(5)+Bs_1}$$

and so

$$\xi_{AC^{-1}(5)} * (.005\xi_{Bs_1} + .99\xi_{Bs_2} + .005\xi_{Bs_3}) \supset .005\xi_{AC^{-1}(5)+Bs_1} + .99\xi_{C^{-1}(5)+Bs_2} + .005\xi_{AC^{-1}(5)+Bs_3}$$

We can then take the right side of the above equation as the transition bound  $F_0 \xi_{C^{-1}(5)}$ . This transition bound is fairly weak, because it introduces a lot of extraneous measures, but it is simple to compute. Notice that since both  $C^{-1}(5)$  and  $Bs_1$  are simplexes, the sum is also a simplex. The three simplexes corresponding to the three simplexes  $s_1, s_2, s_3$  are shown in Figure (3.10).

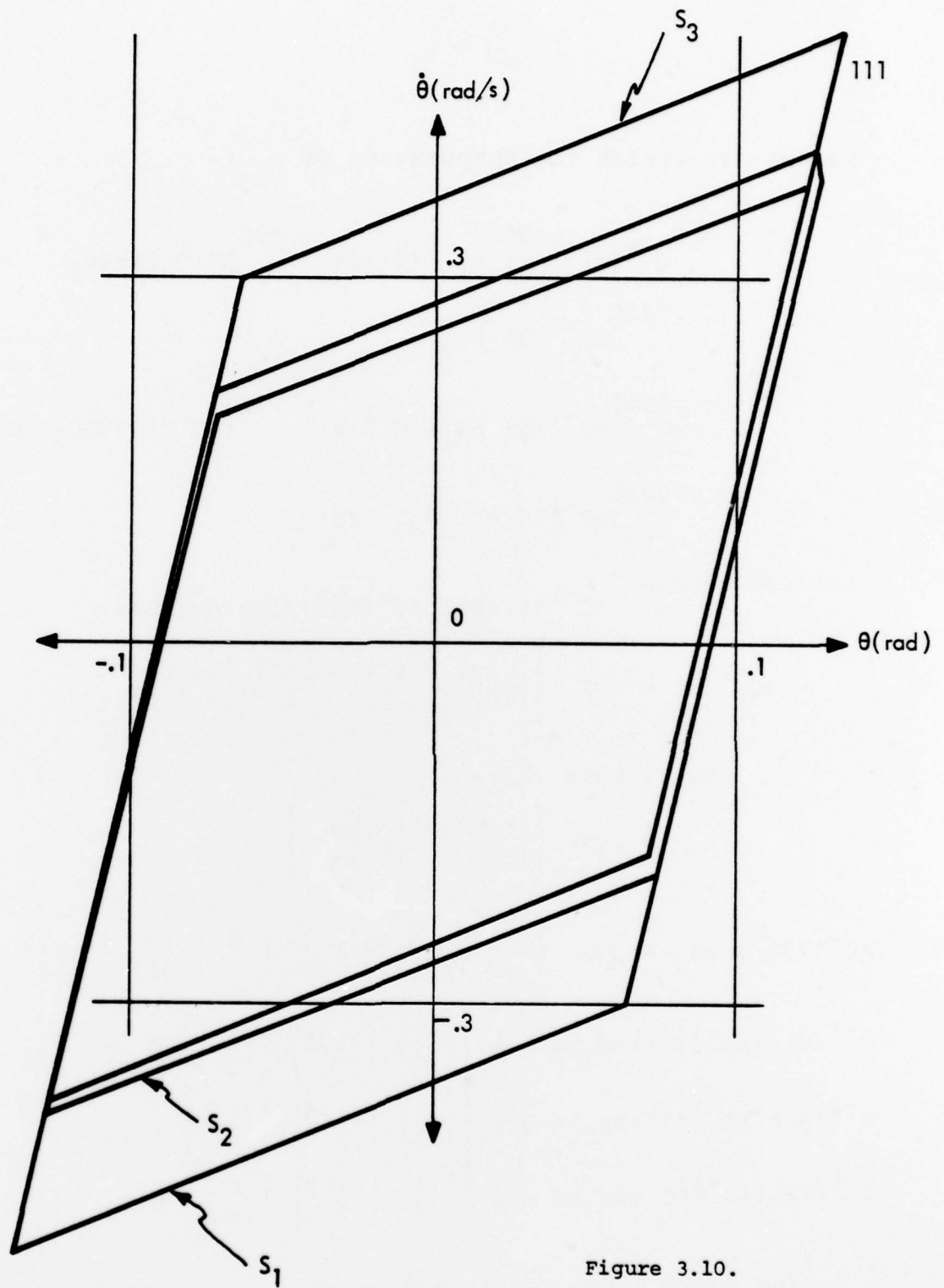

Figure 3.10.

Now we can finish the computation of  $\eta_{\pi_3}$ :

$$\eta_{\pi_1} = P C^{-1}(6) \left( .005\xi_{AC^{-1}(5)+Bs_1} + .99\xi_{AC^{-1}(5)+Bs_2} + .005\xi_{AC^{-1}(5)+Bs_3} \right)$$

$$\eta_{\pi_1} = .005\xi_{AC^{-1}(5)+Bs_1} \wedge C^{-1}(6) + .99\xi_{(AC^{-1}(5)+Bs_2) \wedge C^{-1}(6)} + .005\xi_{(AC^{-1}(5)+Bs_3) \wedge C^{-1}(6)}$$

Let us compute  $\xi_{(C^{-1}(5)+Bs_1) \wedge C^{-1}(6)}$ , for example.

$$AC^{-1}(5) = \text{cvx} \left\{ \begin{bmatrix} .13 \\ .4 \end{bmatrix}, \begin{bmatrix} .07 \\ -.2 \end{bmatrix}, \begin{bmatrix} -.07 \\ .2 \end{bmatrix}, \begin{bmatrix} -.13 \\ -.4 \end{bmatrix} \right\}$$

$$\begin{aligned} Bs_1 &= B \text{cvx} \{-1, -.2\} \\ &= \text{cvx} \left\{ \begin{bmatrix} -.005 \\ -.1 \end{bmatrix}, \begin{bmatrix} -.001 \\ -.02 \end{bmatrix} \right\} \end{aligned}$$

$$AC^{-1}(5) + Bs_1 = \text{cvx} \left\{ \begin{bmatrix} .125 \\ .3 \end{bmatrix}, \begin{bmatrix} .065 \\ -.3 \end{bmatrix}, \begin{bmatrix} -.135 \\ -.5 \end{bmatrix}, \begin{bmatrix} .13 \\ .38 \end{bmatrix}, \begin{bmatrix} -.07 \\ .18 \end{bmatrix}, \begin{bmatrix} -.13 \\ -.42 \end{bmatrix} \right\}$$

$$C^{-1}(6) \wedge (AC^{-1}(5) + Bs_1) = \text{cvx} \left\{ \begin{bmatrix} .1 \\ .3 \end{bmatrix}, \begin{bmatrix} .125 \\ .3 \end{bmatrix}, \begin{bmatrix} .1 \\ .06 \end{bmatrix} \right\} \triangleq T_1, \text{ and also}$$

$$C^{-1}(6) \wedge (AC^{-1}(5) + Bs_2) = \text{cvx} \left\{ \begin{bmatrix} .1 \\ .3 \end{bmatrix}, \begin{bmatrix} .125 \\ .3 \end{bmatrix}, \begin{bmatrix} .1 \\ .06 \end{bmatrix} \right\} \triangleq T_2$$

$$C^{-1}(6) \wedge (AC^{-1}(5) + Bs_3) = \text{cvx} \left\{ \begin{bmatrix} .1 \\ .3 \end{bmatrix}, \begin{bmatrix} .118 \\ .3 \end{bmatrix}, \begin{bmatrix} .1 \\ .102 \end{bmatrix} \right\} \triangleq T_3$$

The above three convex sets specify  $\eta_{\pi_1}$ . To find  $P_1$ , we first compute

$$C^{-1}(1), \dots, C^{-1}(9) \stackrel{F-5}{\wedge} \eta_{\pi_1}$$

$$F_{-5}(.005\xi_{T_1} + .99\xi_{T_2} + .005\xi_{T_3} =$$

$$(.005\xi_{AT_1-5B} + .99\xi_{AT_2-5B} + .005\xi_{AT_3-5B}) * (.005\xi_{Bs_1} + .99\xi_{Bs_2} + .005\xi_{Bs_3})$$

$$= \sum P_{jk} \xi_{jk} \text{ where } \xi_{jk} = \xi_{(AT_j-5B)+Bs_k}, P_{jk} \text{ is prob. coefficient.}$$

In actually performing this type of analysis on the computer, one would like to keep the number of simplexes bounded, for if we were to continue with the present method, the successive histories would have an exponentially growing number of terms. We mention here that it is possible, with only slight weakening of the bounds, to keep the number of terms in each  $\eta_\pi$  constant. Roughly, this can be done by finding some "typical" supports of the simplex measure sets, including a support which is large enough to contain each, and then grouping the simplex measures sets, including a support which is large enough to contain each, and then grouping the simplex measure sets into the "typical" sets.

Now to find a bound for  $\mathbb{P}_1$ , notice that

$$\tau_{C^{-1}(1), \dots, C^{-1}(9)}^{\eta_\pi} C (\tau_{C^{-1}(1)}^{\eta_\pi})^x (\tau_{C^{-1}(2)}^{\eta_\pi})^x \dots x (\tau_{C^{-1}(9)}^{\eta_\pi})^x$$

Also notice that

$$\tau_{C^{-1}(i)}^{\xi_{jk}}$$

is either  $[0], [1],$  or  $[0,1]$  where  $\xi_{jk} = \xi_{(AT_j-5B)+Bs_k}$ , since

if  $C^{-1}(i) \cap \text{infs} P_{jk} \neq \emptyset$ , (the infimal support of  $AT_j-5B+B_s_k$ )  $\tau = 1$ ;

if  $C^{-1}(i) \cap \text{infs} P_{jk} = \emptyset$ ,  $\tau = 0$ , and otherwise any probability between one and zero is possible, since the unit mass is a measure in  $\xi_{jk}$  and the unit mass can be taken in the infimal support.

Thus all we need are the intersections of each of the nine supports  $(AT_j - 5B) + Bs_k$  with each of the nine areas  $C^{-1}(i)$ . When this computation is made, it is found that all nine of the supports either all intersect or all do not intersect each  $C^{-1}(i)$ ; for example, all supports intersect  $C^{-1}(5)$ . Thus

$$\begin{aligned} \mathbb{P}_{C^{-1}(5)} \eta_\pi &= \sum_{\substack{j=1,3 \\ k=1,3}} P_{jk} \mathbb{P}_{C^{-1}(5)} \xi_{jk} \\ &= \sum_{j,k} P_{jk} [0,1] = [0,1] \end{aligned}$$

So  $P_5$  is the same for the noisy pendulum as for the deterministic one. I have not actually calculated  $P$  for the noisy pendulum but each  $P_i$  can be calculated as we have calculated  $P_5$ . The analysis of the noisy pendulum follows exactly the same lines as the analysis of the deterministic, except for the minor change that the  $\eta_\pi$ 's are no longer representable by single convex support sets, but instead require a collection of support sets and weights. It is clear that simplex measure sets are well-suited to the type of analysis of finite-state compensation systems we have outlined here.

### 3.3 Simplex Measure Sets

In the previous sections we motivated the simplex measure sets in the context of balancing an inverted pendulum. In this section we formalize the notions and will find a tighter

transition bound  $F$  for linear systems than the one used previously. This material is, however, somewhat technical.

Consider, from Example (3), section 2.2., the measure set  $\eta_p$ , where

$$\eta_p = \{\mu \mid \mu(-\infty, 0) = 1-p, (0, \infty) = p\}$$

In the notation of the previous section we would write:

$$\eta_p = (1-p) \xi_{(-\infty, 0)} + p \xi_{(0, \infty)}$$

Suppose we wish to bound the set  $\eta_p * \eta_p$ . Using the method of the previous section, we would take:

$$\begin{aligned} \eta_p * \eta_p &\subset (1-p)^2 \xi_{(-\infty, 0) + (-\infty, 0)} + 2p(1-p) \xi_{(-\infty, 0) + (0, \infty)} + p^2 \xi_{(0, \infty) + (, \infty)} \\ &= (1-p)^2 \xi_{(-\infty, 0)} + 2p(1-p) \xi_{(-\infty, \infty)} + p^2 \xi_{(0, \infty)} \end{aligned}$$

As an example of a measure that is in the right-hand measure set but not in the left hand set, consider

$$\mu = (1-p)^2 \delta_{-1} + (1-(1-p)^2) \delta_1$$

To see that  $\mu$  is not in  $\eta_p * \eta_p$ , first observe that due to the positivity constraint, if  $\eta_p * \eta_p$  then there must be a

$$\mu_1 = a_1 \delta_{x_1} + b_1 \delta_{y_1} \text{ and } \mu_2 = a_2 \delta_{x_2} + b_2 \delta_{y_2} \text{ such that}$$

- 1)  $x_1 x_2 \in (-\infty, 0,)$
- 2)  $y_1 y_2 \in (0, \infty)$
- 3)  $x_1 + y_2 = -1$  ,  
 $x_1 + x_2 = 1$   
 $y_1 + x_2 = 1$   
 $y_1 + y_2 = 1$

$$4) \quad a_1 a_2 = (1-p)^2, \quad a_1 b_2 + b_1 a_1 + b_1 b_2 = 1 - (1-p)^2$$

$$5) \quad a_1 > 0, \quad a_2 > 0, \quad b_1 > 0, \quad b_2 > 0$$

i.e.,  $\mu_1 * \mu_2 = \mu$ . However, there is no solution to the above condition for  $x, y, a$ , and  $b$ .

This suggests an alternate description of simplex measure sets, which can exclude the possibility shown above.

Suppose we describe the convex set  $\eta_p$  from Example (1) in terms of a set of "extreme points." The set

$$s_p = \{ \delta_{x_1 x_2} \mid x_1 < 0, x_2 > 0 \}$$

where  $\delta_{x_1 x_2}$  is the measure on  $\mathbb{R}$  with mass  $(1-p)$  at  $x_1$  and mass  $p$  at  $x_2$ , could be considered the extreme points of  $\eta_p$ . Certainly the convex hull of  $s_p$  is in  $\eta_p$ , but to get equality we must consider an extended kind of convex combination.

Notice first that the set  $s_p$  is naturally isomorphic to a set  $s_x = (-\infty, 0) \times (0, \infty) \subset \mathbb{R}^2$ , where we associate  $\begin{pmatrix} x_1 \\ x_2 \end{pmatrix} \in s_x$  with  $\delta_{x_1 x_2}$ . This enables us to define a "continuous" convexity of the elements in  $s_p$  by means of a positive measure  $\rho$  on  $\mathbb{R}^2$  with unit mass in  $s_x$ :

$$\int_{s_x} \delta_{x_1 x_2} d\rho$$

represents a measure on  $\mathbb{R}^1$  defined by

$$\left( \int_{s_x} \delta_{x_1 x_2} d\rho \right) (B) = \int_{s_x} \delta_{x_1 x_2} (B) d\rho, \quad B \in \mathbb{B}^1$$

Since  $\rho(s_x) = 1$  the resulting measure will be a probability measure, and furthermore

$$\eta_\rho = \left\{ \int_{s_x} \delta_{x_1 x_2} d\rho \mid \rho > 0, \rho(s_x) = 1 \right\}$$

This representation of  $\eta_\rho$  is a "simplex" representation because the measure set is completely specified by the simplex  $s_x$  and mass vector  $\begin{pmatrix} .5 \\ .5 \end{pmatrix}$  for  $x_1$  and  $x_2$ . The advantage of using this somewhat cumbersome representation is the ease in bounding the set of pairwise convolutions of measures in  $\eta_\rho$ , for we see that

$$\begin{aligned} \eta_\rho * \eta_\rho &= \left\{ \int_{x = \begin{pmatrix} x_1 \\ x_2 \end{pmatrix} \in s_p} \delta_{x_1 x_2} d\rho * \int_{x^1 = \begin{pmatrix} x_1^1 \\ x_2^1 \end{pmatrix} \in s_p} \delta_{x_1^1 x_2^1} d\rho^1 \mid \rho(s_x) = 1, \rho^1(s_x) = 1 \right\} \\ &= \left\{ \int_{x \in s_p} \int_{x^1 \in s_p} \delta_{x_1 x_2} * \delta_{x_1^1 x_2^1} dp d\rho^1 \mid \dots \right\} \end{aligned}$$

Now let  $\delta_{y_1 y_2 y_3 y_4}$  be the measure with mass  $(1-p)^2$  at  $y_1, (1-p)$ ; at  $y_2, y_3$  and  $p^2$  at  $y_4$ , so that

$$\delta_{x_1 x_2} * \delta_{x_1^1 x_2^1} = \delta_{(x_1+x_2^1) (x_1+x_2^1) (x_2+x_1^1) (x_2+x_2^1)}$$

Given  $x \in s_x$  and  $x^1 \in s_x$  the possible values for

$y = (y_1 y_2 y_3 y_4) = ((x_1+x_1^1) (x_1+x_2^1) (x_2+x_1^1) (x_2+x_2^1))$  are in the set:

$$\left\{ \begin{pmatrix} x_1+x_1^1 \\ x_1+x_2^1 \\ x_2+x_1^1 \\ x_2+x_2^1 \end{pmatrix} : \begin{pmatrix} x_1 \\ x_2 \end{pmatrix} \in s_x, \begin{pmatrix} x_1^1 \\ x_2^1 \end{pmatrix} \in s_x \right\} \triangleq +*(s_x, s_x)$$

which is the same set as:

$$\left\{ w_1 \begin{pmatrix} -1 \\ -1 \\ 0 \\ 0 \end{pmatrix} + w_2 \begin{pmatrix} -1 \\ 0 \\ -1 \\ 0 \end{pmatrix} + w_3 \begin{pmatrix} 0 \\ 0 \\ 1 \\ 1 \end{pmatrix} + w_4 \begin{pmatrix} 0 \\ 1 \\ 0 \\ 1 \end{pmatrix} \mid w_1 - w_4 \in [0, \infty) \right\}$$

which is again a simplex. Thus  $\eta_p^* \eta_p$  is bounded by another simplex measure set.

$$\left\{ \eta_p^* \eta_p \subset \int_{+^*(s_x, s_x)} \delta_y dp \mid \rho(+^*(s_x, s_x)) = 1 \right\}$$

It is clear from the way we defined  $+^*(s_x, s_x)$ , that the measure  $\mu = (1-p)^2 \delta_{-1} + (1-(1-p))^2 \delta_1$  is not in the right-hand set, so this method of bounding convolutions is superior to the one used in the previous sections.

The above comments are mentioned incidentally in this thesis, so we will not go through a completely formal development. But some generalization is in order.

Definition. A simplex  $S \subset \mathbb{R}^n$  is a mass simplex if for every  $s \in S$ ,  $s \geq 0$  and  $(1 \ 1 \ \dots \ 1)s = 1$ .

Definition.  $(x, m)$  is an  $(n, k)$  vector-mass pair if  $x$  is a real  $n$  by  $k$  matrix and  $m \in \mathbb{R}^k$  is an element of a mass simplex.

Notation. Let  $(x, m)$  be an  $(n, k)$  vector-mass pair and let  $x$  be the matrix of columns  $x^1, x^2, \dots, x^k$ , and let  $m = (m_1, \dots, m_k)^T$ . We denote the measure on  $\mathbb{R}^n$  with mass  $m_i$  at  $x^i$ ,  $i=1, \dots, k$ , by  $\delta_{(x, m)}$ .

Definition. Let  $\eta$  be a measure set on  $\mathbb{R}^n$ .  $\eta$  is a simplex

measure set if there exists a simplex  $s_x \subset \mathbb{R}^{nk}$  and a mass simplex  $s_m \subset \mathbb{R}^k$  such that

$$\eta = \left\{ \mu : \mu = \int_{s_x \times s_m} \delta_{(x,m)} d\rho d\sigma, \rho(s_x) = 1, \sigma(s_m) = 1, \rho \geq 0, \sigma \geq 0 \right\}$$

where the integral is defined as the measure

$$\left[ \int_{s_x \times s_m} \delta_{(x,m)} d\rho d\sigma \right] (B) = \int_{s_x \times s_m} \delta_{(x,m)} (B) d\rho d\sigma \quad B \in \mathcal{B}$$

If  $\eta$  is a simplex measure set we write  $\eta = \text{cvx}(s_x, s_m)$ , since  $s_x$  and  $s_m$  are unique for each simplex measure set.

In addition, every pair  $(s_x, s_m)$  yields a measure set, and we define the simplex measure space on  $\mathbb{R}^n, \mathcal{S}^n$ , to be the set of all simplex measure sets on  $\mathbb{R}^n$ .

$\mathcal{S}^n$  also satisfies all the axioms of an ambiguous measure space, and the only difficulty in showing this is showing that  $P_s(y) \in \mathcal{S}^n$  where  $s$  is representable and  $\eta \in \mathcal{S}^n$ . We will omit the proof here.

### 3.4. Topics for Future Research

In this thesis we have shown, on a rigorous basis, how ambiguous processes can be used to analyse the performance of complex nonlinear feedback systems. In the past sections we have shown how a conceptualization  $\Pi$  can be methodically computed, and how a transition bound  $\mathcal{F}$  arises naturally for linear systems with simplicial measure set uncertainty, and these two objects then define an ambiguous process from which performance bound can be obtained. The next step, a possible topic for future research, is to precipitate an actual bounding algorithm for finite-state compensated systems.

Another very interesting topic for future research is a design methodology based on ambiguous processes. Our preliminary results in this area were too scanty for presentation here, but it seems that memoryless compensators with a fixed coder and fixed plant have sufficient structure that optimization can be performed. Unfortunately, the design of finite-state compensators with memory seems to be a very different, and a very important problem for future research, because the possible set of observations depends on the compensator's memory structure, a situation which does not arise in the memoryless case or in classical control. However, it is also likely that in such complex design problems, general theoretical simplifications can only be made to a limited extent, and design must rest on searching strategies (as in stochastic control.) Still the end results would be directly implementable controllers with very definite performance bounds, and

so the design of compensators using ambiguous processes as a methodology would certainly seem an interesting problem for future research.

## REFERENCES

- [1] Minsky, M. Computation: Finite & Infinite Machines, Prentice-Hall, Englewood Cliffs, N.J., 1967.
- [2] Freeman, H. Discrete-Time Systems: An Introduction to the Theory. John Wiley & Sons, Inc., New York, 1965.
- [3] Kalman, R.E., Falb, P., and Arbib, M., Topics in Mathematical System Theory, McGraw-Hill, New York, 1969, Chapter .
- [4] Padulo, L. and Arbib, M., System Theory: A Unified Approach to Continuous and Discrete-Time Systems, W.B. Saunders Co., Philadelphia, Pa., 1970.
- [5] Davis, Kenneth P. "Integer-State Feedback Compensators as an Approach to Finite-State Compensators," MIT S.B. Thesis, August 1977.
- [6] Kalman, Falb, Arbib, Chapter .
- [7] Johnson, T.L., "Finite-State Compensators for Continuous Processes" ESL Working Paper P-812, December 1977.
- [8] Athans, M. and Falb, P., Optimal Control, McGraw-Hill Book Co., New York, 1966.
- [9] Sandell, N.R., "Control of Finite-State, Finite-Memory Stochastic Systems" MIT S.M. Thesis, 1974.
- [10] Zadeh, L., ed., Fuzzy Sets and Their Applications to Cognitive and Decision Processes, Academic Press, New York, 1975.
- [11] Schweppe, F., Uncertain Dynamic Systems, Prentice-Hall, Englewood Cliffs, N.J., 1973.
- [12] Rudin, W., Real and Complex Analysis, McGraw-Hill Inc., New York, 1974.
- [13] Gantmacher, Theory of Matrices, Vol II, Chelsea Publishing Co., 1959.
- [14] Karlin, S., and Taylor, H., A First Course in Stochastic Processes, Academic Press, New York, 1975.
- [15] Avriel, M. Nonlinear Programming. Prentice-Hall, Englewood Cliffs, N.J., 1975.