

AD-A062 850

OHIO STATE UNIV COLUMBUS ELECTROSCIENCE LAB
COMMUNICATION APPLICATIONS OF ADAPTIVE ARRAYS.(U)
OCT 78 R T COMPTON

F/G 17/2

UNCLASSIFIED

FSL-710929-4

N00019-78-C-0131

NL

1 OF 1
AD
A062 850



END
DATE
FILMED
2-79
DDC

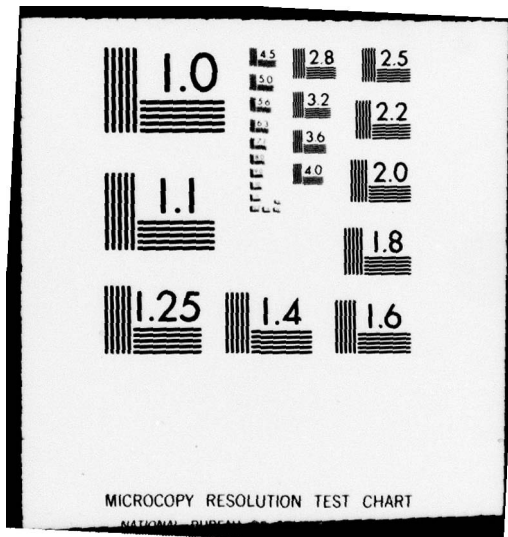

MICROCOPY RESOLUTION TEST CHART

NATIONAL BUREAU OF STANDARDS-1963-A

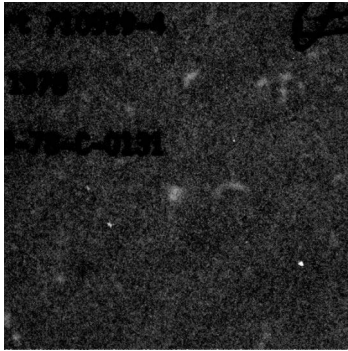

FSL

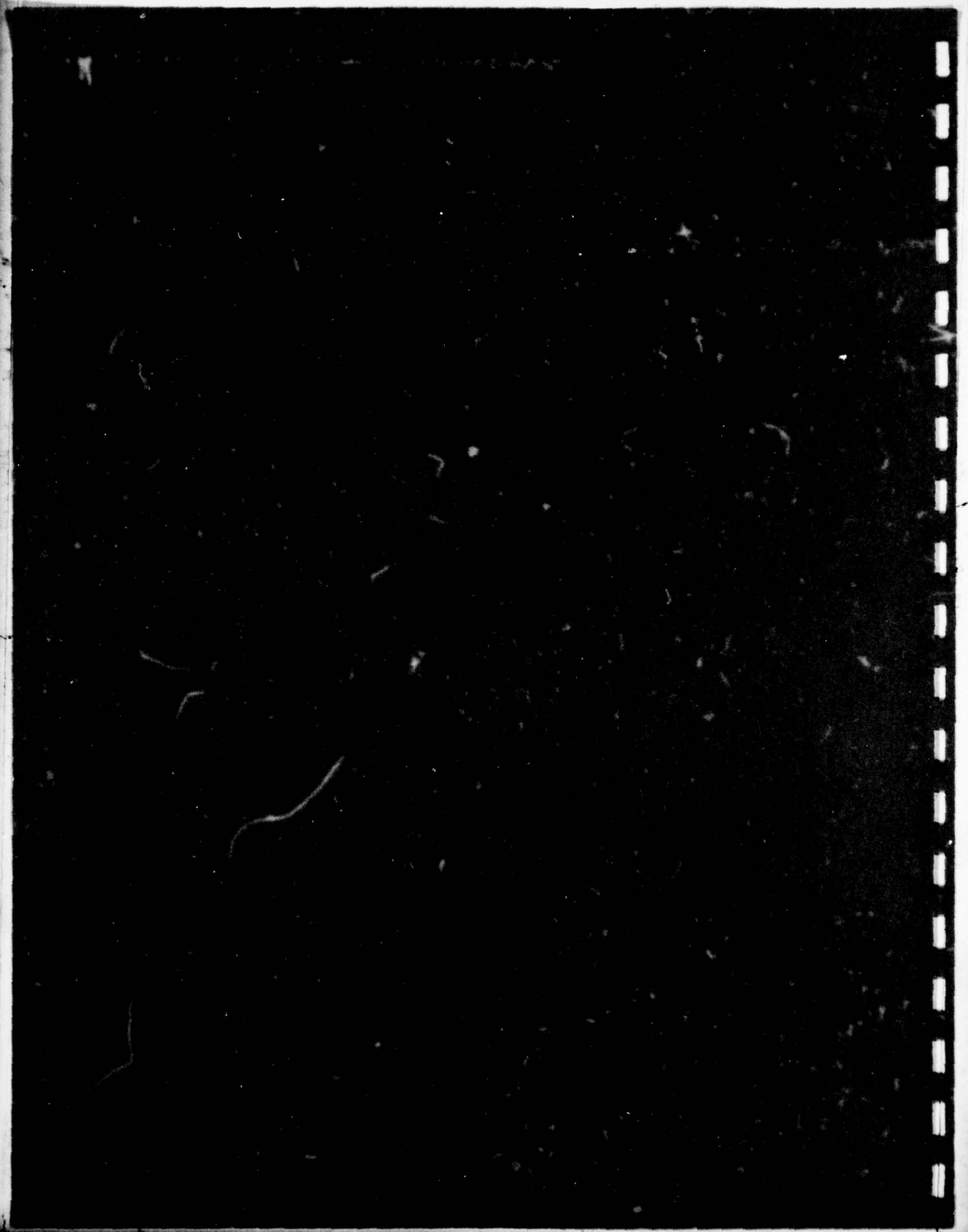

UNCLASSIFIED

SECURITY CLASSIFICATION OF THIS PAGE (When Data Entered)

REPORT DOCUMENTATION PAGE		READ INSTRUCTIONS BEFORE COMPLETING FORM
1. REPORT NUMBER	2. GOVT ACCESSION NO.	3. RECIPIENT'S CATALOG NUMBER
4. TITLE (and Subtitle) 6 Communication Applications of Adaptive Arrays		5. TYPE OF REPORT & PERIOD COVERED 9 Quarterly Report
7. AUTHOR(s) 10 R. T. Compton, Jr		6. PERFORMING ORG. REPORT NUMBER 14 ESL-710929-4
9. PERFORMING ORGANIZATION NAME AND ADDRESS The Ohio State University ElectroScience Laboratory, Department of Electrical Engineering Columbus, Ohio 43212		7. CONTRACT OR GRANT NUMBER(s) 15 Contract N00019-78-C-0131
11. CONTROLLING OFFICE NAME AND ADDRESS Department of the Navy Naval Air Systems Command Washington DC 20361		10. PROGRAM ELEMENT, PROJECT, TASK AREA & WORK UNIT NUMBERS Project N00019-78-PR-PJ005
14. MONITORING AGENCY NAME & ADDRESS (if different from Controlling Office) 11 Oct 78 / 12 8 p		12. REPORT DATE OCT - 1978
		13. NUMBER OF PAGES 4
		15. SECURITY CLASS. (of this report) Unclassified
		15a. DECLASSIFICATION/DOWNGRADING SCHEDULE
16. DISTRIBUTION STATEMENT (of this Report) APPROVED FOR PUBLIC RELEASE: DISTRIBUTION UNLIMITED		
17. DISTRIBUTION STATEMENT (of the abstract entered in Block 20, if different from Report)		
18. SUPPLEMENTARY NOTES		
19. KEY WORDS (Continue on reverse side if necessary and identify by block number) Adaptive arrays Communications Interference rejection		
20. ABSTRACT (Continue on reverse side if necessary and identify by block number) This report describes progress under Naval Air Systems Command Contract N00019-78-C-0131 during the third quarterly period. Research on the use of adaptive arrays in conventional communication systems is summarized.		

DD FORM 1 JAN 73 1473

EDITION OF 1 NOV 65 IS OBSOLETE

UNCLASSIFIED

SECURITY CLASSIFICATION OF THIS PAGE (When Data Entered)

402 252

slf

CONTENTS

	Page
INTRODUCTION	1
PROGRESS	1
(1) Frequency and Code Timing Acquisition	1
(2) Frequency Shift Keyed Signals in Adaptive Arrays	3
REFERENCES	4

ACCESSION for	
NTIS	Wide Area Mon <input checked="" type="checkbox"/>
DDC	D. H. S. <input type="checkbox"/>
UNANNOUNCED	<input type="checkbox"/>
JUL 1 1979	
BY	
DIS	SPECIAL
A	

79 01 02 014

INTRODUCTION

This report describes progress under NASC Contract N00019-78-C-0131 during the third quarterly period. There are four areas of work under this contract. The first is a continuation of experimental work, started under the previous contract, on the use of adaptive arrays with AM and FM signals. The second and third areas involve research on the problem of frequency acquisition in adaptive arrays and the use of analog phase modulation for desired signal tagging. The last area involves the preparation of a monograph on adaptive arrays.

PROGRESS

During this quarter, work has been done in two areas as described below:

(1) Frequency and Code Timing Acquisition

Studies on methods of acquiring frequency and code timing behind an adaptive array have been continued. The technique being considered involves the use of a power inversion array with a dithered loop gain. The desired signal is biphasic modulated with a PN code, and has an unknown frequency and code timing. A coupled phase lock loop (PLL) and delay lock loop (DLL) are used behind the power inversion array to generate the reference signal, as shown in Figure 1. Use of gain dithering in the array creates a time window during which the desired signal is the dominant signal in the array output. The coupled PLL and DLL acquire lock during this interval. After the system is locked, the array is switched to a conventional LMS feedback mode.

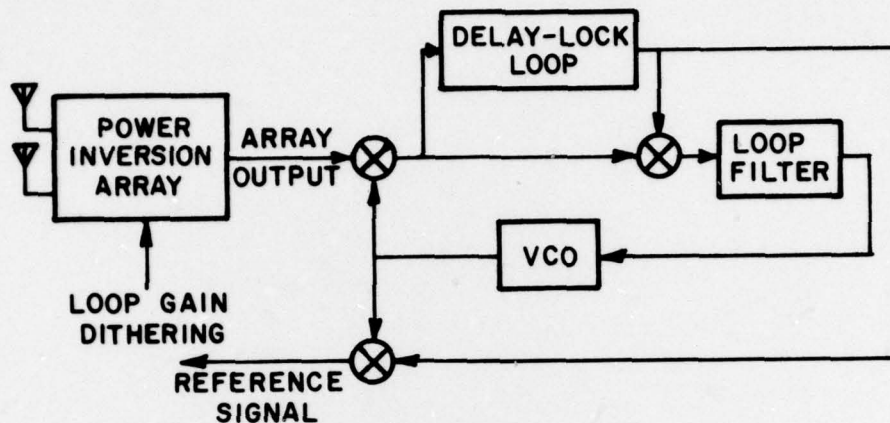

Figure 1. Dithered array with coupled PLL and DLL.

Locking the coupled PLL and DLL during the time window is done by slewing the local Pseudonoise (PN) code in the DLL. When the timing of the local code is aligned with that of the received code, the PLL can lock in the conventional manner. (With the codes aligned, the biphas modulation is invisible to the PLL.) With the PLL locked, the input to the DLL is then a clean version of the incoming PN code, so the DLL can then lock. For this process to work properly requires that the time window provided by the array, and the time duration when the two codes are aligned, be long enough for both the PLL and the DLL to lock, in sequence.

The time required for an ordinary PLL to lock is determined by the type of loop filter used, the loop gain and the initial frequency and phase errors, as discussed by Viterbi¹. The PLL lockup in this application, however, differs from a conventional PLL lockup because of the presence of the phase switching. The PLL will first begin to lock when the two PN codes are still slightly out of adjustment.

A code timing misadjustment causes the loop gain in the PLL to reverse sign at each PN code bit transition, and this delays the lock-up.

Analytical studies and computer simulations are currently being done on the lockup behavior of this system.

(2) Frequency Shift Keyed Signals in Adaptive Arrays

A technique is presently being studied for using adaptive arrays with binary frequency shift keyed (FSK) communication systems. The technique makes use of the symbol transition probabilities in the FSK bit stream. The bit stream is assumed to be a Markov source² with known transition probabilities. The transition probabilities are chosen so that transitions in one direction are more likely than in the other (so that, for example, after a zero, a one is more likely than another zero). With the transitions biased in this manner, it is possible to predict from each received bit what the next bit will be, and the result will be correct more often than not. The predicted bit is used to generate a reference signal for the array by switching on one of two CW frequencies for the reference signal. A reference signal derived in this manner has good correlation with the desired signal, and does not correlate with, say, a CW interference signal. Simulations have been performed for an array operating with this method of reference signal generation, and the results indicate that the array will perform properly. This work is continuing.

REFERENCES

1. A. J. Viterbi, Principles of Coherent Communication, McGraw-Hill Book Co., New York, 1966.
2. N. Abramson, Information Theory and Coding, McGraw-Hill Book Co., New York, 1968.