

AD-A062 855

ROYAL AIRCRAFT ESTABLISHMENT FARNBOROUGH (ENGLAND)  
AN AUTOMATIC PORTABLE TELECINE CAMERA. (U)  
AUG 78 J B HUMPHREYS, P J MITCHELL

F/G 14/5

UNCLASSIFIED

RAE-TM-IT-177

DRIC-BR-65142

NL

1 OF 1  
ADA  
062855

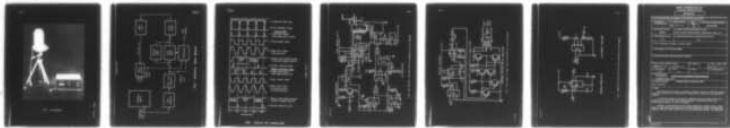

END  
DATE  
FILMED

3 -79  
DDC

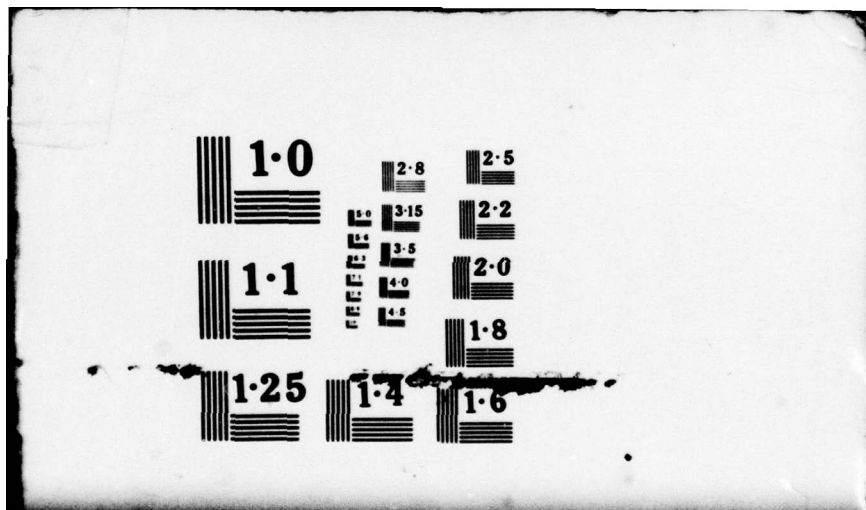

14

TECH. MEMO  
RAE-TM-IT-177

**LEVEL II**  
**UNLIMITED**

19 BR65142

TECH. MEMO  
IT 177

18 DRIC

1

AD A062855

ROYAL AIRCRAFT ESTABLISHMENT

9 Technical memo.

6

AN AUTOMATIC PORTABLE TELECINE CAMERA

by

10 J.B. Humphreys  
P.J. Mitchell

11 August 1978

12 19p.

DDC FILE COPY

DDC  
RECORDED  
DEC 21 1978  
REGISTERED

78 12 15 046  
UNLIMITED  
310450

Handwritten initials

# LEVEL II

## ROYAL AIRCRAFT ESTABLISHMENT

Technical Memorandum IT 177

Received for printing 23 August 1978

### AN AUTOMATIC PORTABLE TELECINE CAMERA

by

J.B. Humphreys

P.J. Mitchell

#### SUMMARY

↙ This Memorandum describes an automatic portable telecine system that enables television records to be transferred to 16 mm film for analysis or demonstration purposes.

A television display is filmed by a modified 16 mm cine camera driven by a control unit in which the camera supply voltage is derived from the field synchronisation pulses of the video signal.

Automatic synchronisation of the camera mechanism is achieved over a wide range of television field frequencies and the shutter bar effect, resulting from exposure time and camera speed errors in non-synchronised systems, is eliminated. ↗

This item is covered by Patents Application No.34348/78.

CLASSIFIED	White Section	<input checked="" type="checkbox"/>
SECRET	Grey Section	<input type="checkbox"/>
UNANNOUNCED		<input type="checkbox"/>
JUSTIFICATION		
BY		
DISTRIBUTION/AVAILABILITY CODE		
CSL	AVAIL.	and/or SPECIAL
A		

Copyright  
©  
Controller HMSO London  
1978

DDC  
RECEIVED  
DEC 21 1978  
RECEIVED  
D

78 12 15 046

LIST OF CONTENTS

	<u>Page</u>
1 INTRODUCTION	3
2 THE REQUIREMENT FOR A TELECINE FACILITY	3
3 THE ESSENTIAL FEATURES OF A TELECINE SYSTEM	5
4 THE EQUIPMENT	7
5 PRINCIPLES OF OPERATION	8
6 PERFORMANCE CHARACTERISTICS	9
7 RESULTS OBTAINED	10
Reference	10
Illustrations	Figures 1-7
Report documentation page	inside back cover

## 1 INTRODUCTION

The increasing use of closed circuit television equipment has led to a growing need for the production of cine film copies of videotape records. There are a number of reasons for this, dealt with in section 2, which arise primarily from the limitations of videotape recorders.

A few commercial studios offer telecine facilities, but the service is relatively expensive and recordings which do not conform to broadcast standards are not generally accepted. On this basis, therefore, it was not possible to process recordings made with the majority of portable video recorders or specialised television equipment.

As a result of enquiries received from users of a variety of television equipment, including one in which real time, high resolution, photography of a television monitor in an aircraft engaged in flight trials was required, it was decided that the development of a telecine system based on known RAE requirements should be undertaken.

The primary requirements were that the equipment had to be simple to operate, very portable and capable of operating with any video recorder or television camera. The need for simplicity and portability prohibited the use of a complex recording camera and the design was based on a commercial 16 mm cine camera. This was modified to operate in synchronism with a television display with the minimum of electronic control equipment.

A prototype was produced and its use led to the construction of the equipment described, two significant improvements being that camera synchronisation was made to be fully automatic and the electronic control equipment was housed in a single case instead of two.

## 2 THE REQUIREMENT FOR A TELECINE FACILITY

Although the video recorder has some advantages over film, particularly in terms of long duration recording and instant replay, there are many instances where it is desirable to transfer material from videotape or a television camera to 16 mm film and some of these are described below.

### 2.1 Record editing

Whereas 16 mm film can be edited with precision using simple equipment, videotape cannot be satisfactorily edited without the use of two recorders, one of which should have electronic edit facilities. Even if the appropriate equipment is available it is usually not possible to select a specific frame and, in

any case, the process is one of replication, the disadvantages of which are dealt with in section 2.2.

## 2.2 Replication

A film record may be used as a master to produce, both quickly and cheaply, many copies with only a minimal loss of picture quality. A videotape, however, cannot be copied without some loss in resolution, an increase in noise level, and a reduction in synchronising pulse timing accuracy; moreover since each copy must be made at normal replay speed the process is time consuming if many copies are required.

## 2.3 Demonstration

The demonstration of videotape records presents several problems, especially if the audience is large and it is necessary to repeat the demonstration at different locations.

A television monitor is not a suitable form of display for more than a few people and, if several monitors are used, the quantity of equipment involved becomes significant. The display problem can be overcome by using a television projector but this is a bulky and expensive item.

In contrast, 16 mm cine film projectors are available in most locations and will produce a large screen display. In addition the transfer of videotape to film enables video and cine records to be incorporated into a single demonstration film, thus eliminating the need for a multiplicity of equipment.

## 2.4 Record analysis

Analytical 16 mm film projectors with single/multiple frame advance facilities and image displacement measuring graticules are readily available. Video reproducers, however, have not been developed specifically for detailed analysis by image measurement techniques, and there is a loss of picture resolution on those machines which do have single frame operation.

## 2.5 Recording of high definition pictures

The definition of videotape recordings is limited by the bandwidth of the recorder used; this can vary from about 2 MHz for low cost machines to about 6.5 MHz for specialised equipment. With the increasing use of high definition systems having bandwidths of 10 MHz and above, satisfactory recording presents a serious problem.

The problem can be largely overcome by the use of a telecine system which records the television display in real time, so that the limit in resolution is determined only by the television camera and monitor performance.

### 3 THE ESSENTIAL FEATURES OF A TELECINE SYSTEM

The principles of operation of a television display dictate a number of camera requirements that must be met in order that a satisfactory film record may be obtained. Some of these are discussed below.

#### 3.1 Exposure duration (see Fig 1)

In a standard 625 line 50 fields per second television display format each frame, or complete 625 line picture, is composed of two fields and therefore is compiled in 40 ms; thus to record one television frame the exposure time of the telecine camera must also be 40 ms. A shorter exposure will result in a section of one field being absent (causing a light horizontal bar in the picture area), and a longer exposure will result in an area of overlap between two fields (causing a dark horizontal bar). This is commonly referred to as the shutter bar effect.

Due to the finite opening and closing time of the cine camera sector shutter it is not possible to eliminate the problem entirely by adjustment of the exposure duration alone, but choice of the optimum exposure will ensure that the effect is minimised.

#### 3.2 Film transport

The film transport and shutter mechanism of a cine camera has two operational states, the period when the shutter is open and the film is stationary, the exposure time, and the period when the shutter is closed and the film is being transported in readiness for the next exposure, the pull-down time. In the perfect telecine system the pull-down time should be less than the field blanking period of the television display. This is the period between two fields, in which the video information is suppressed at black level while the vertical scan circuit resets in readiness for the next field pulse, and it is generally about 1.7 ms in duration.

Conventional cameras, however, have pull-down times in the order of 20 ms so that one of the following approaches must be adopted.

(a) Reduction of pull-down time

This requires a specialised design of the film transport mechanism and is only incorporated in one commercially available camera, the American Teledyne (see Ref 1) developed for broadcast standard telecine applications, which uses a compressed air drive for operating the film transport. It is a bulky and expensive item and forms part of a large permanent installation.

(b) Field skipping

In this mode of operation the camera is only required to record two fields in three, this allows one field period, 20 ms, in which to complete the pull-down process. Each picture will still be made up of two fields, 625 lines, and as most television applications involve only a small change in information between fields, the loss of one field will not normally be significant.

In order to meet the requirements for low cost and portability this was the technique adopted in the equipment described.

3.3 Camera framing rate

In order to record two fields in three the camera framing speed must be  $F/3$ , where  $F$  is the television field frequency. This gives a speed of  $16\frac{2}{3}$  pictures per second for a 50 fields per second display.

Many cine cameras operate at 16 pictures per second but at this speed the shutter bar would drift slowly through the projected picture at a rate determined by the relationship between the camera speed and the television field frequency. It is, therefore, essential to synchronise these two parameters in order to obtain a stationary shutter bar which can be phased out of the picture area as described in section 3.4.

3.4 Shutter phasing (see Fig 1)

If the camera speed is synchronised to the television field frequency a stationary shutter bar will be visible, as described in section 3.3, and its position in the picture area will depend on the relationship between the camera shutter opening time and the start of the television frame scan. To overcome this the camera shutter must be phased to open at the start of a frame scan; this will ensure that the shutter bar effect, caused by an imprecise exposure duration, occurs during the field blanking period and so does not appear in the picture area of the projected film.

### 3.5 Portability

A specific requirement that the equipment could be used for real time recording in an aircraft dictated that it should be very portable and simple to set up and operate.

### 3.6 Compatability

Videotape records vary considerably in terms of picture quality, synchronisation pulse timing accuracy and field frequency, depending on the type of camera and recorder used. In view of this, and a requirement for the transfer to film of American standard 525 line 60 fields per second video records, it was important that the system should accept a wide range of field frequencies, the range chosen being from 45 to 65 fields per second.

## 4 THE EQUIPMENT (see Fig 2)

The basic telecine equipment consists only of a camera and control unit which are described below, the video monitor and recorder being supplied by the customer.

### 4.1 Camera

The camera chosen was a Vinten 16 mm Television Recording Camera having the following basic features:-

(a) A film transport mechanism driven by a 240 volt synchronous motor so that the film speed is determined by the frequency of the supply voltage.

The camera is geared to give  $16\frac{2}{3}$  pictures per second at 50 Hz.

(b) A rotating sector shutter with a 240 degree open sector giving a shutter open time of 40 ms and a closed period, for pull-down, of 20 ms, at a film speed of  $16\frac{2}{3}$  pictures per second.

(c) Overall dimensions of 197 × 111 × 286 mm, excluding the magazine.

(d) A film capacity of 60 m giving a recording time of 8 minutes.

### 4.2 Control unit

The control unit is housed in an instrument case measuring 335 × 254 × 133 mm and has three push button controls as follows:

(a) Mains on/off switch.

(b) Camera on - providing the camera drive voltage.

(c) Auto - for automatic synchronisation.

Also incorporated are an indicator lamp to show correct camera synchronisation, a film run out indicator, and a series of lamps to show the circuit conditions at various critical points.

The present unit is mains powered but could, if required, be modified to operate from a low voltage dc supply.

## 5 PRINCIPLES OF OPERATION

This section describes the method by which the camera mechanism is synchronised to the field synchronisation pulses of the input video signal. Reference should be made to the block diagram Fig 3, the waveform diagrams Fig 4, and the circuit diagrams Figs 5, 6 and 7.

### 5.1 Video input

The composite video signal from a tape recorder or television camera is processed by a sync separator circuit giving an output of positive going pulses equivalent to the input field synchronisation pulses.

This output is fed to the phase shift and comparator circuits.

### 5.2 Shutter pulse

In order to maintain the correct phase relationship between the field synchronisation pulses and the time at which the camera shutter becomes fully open (see section 2.4), the camera shutter was modified by the addition of a photo electric transducer to give a shutter opening reference pulse. This pulse is also fed to the comparator circuit.

### 5.3 Phase shift circuit

In manual operation this circuit enables the phase of the pulses generated by the sync separator to be adjusted manually with respect to the camera shutter pulse until the two are co-incident. The camera shutter is then phased correctly and an indicator lamp shows that synchronisation has been achieved. In practice this process was found to be cumbersome and an automatic facility was added.

When automatic operation is selected the comparator senses the phase error and selects each of a series of 16 delay circuits, each set to 1 ms, until coincidence between the field pulses and shutter pulses is achieved, correct synchronisation again being shown by the indicator lamp. The tolerance on pulse coincidence is approximately  $\pm 0.5$  ms.

#### 5.4 Pulse shaper

This converts the output of the phase shift circuit, a series of short duration pulses, to a 1:1 mark space ratio square wave, at the television field frequency, which is then fed to the camera motor drive section.

#### 5.5 Motor drive

This consists of a transformer coupled power amplifier which converts the pulse shaper output to a 240 volt rms sinusoidal waveform to drive the camera motor.

This output, therefore, is produced at the field frequency of the input video signal, ensuring the correct camera speed, and is correctly phased with respect to the camera shutter reference pulse.

### 6 PERFORMANCE CHARACTERISTICS

#### 6.1 Camera film speed

The exposure time to camera speed relationship gives a narrow shutter bar which is contained in the field blanking period of 1.7 ms, this indicates an accuracy in film speed of 1.7 ms in a shutter rotation time of 60 ms or  $\pm 1.5\%$ .

#### 6.2 Lock-on time

In the automatic mode of operation the camera takes approximately five television frames to achieve synchronous operation, that is about 0.2 second.

#### 6.3 Video recorder noise immunity

The synchronisation pulse separator circuit has been designed to ensure satisfactory operation even in the presence of poor quality synchronisation pulses and noise that are often generated by video recorders on tape replay.

#### 6.4 Automatic stop facility

As the camera drive voltage depends on the presence of field synchronisation pulses, the camera will cease to run if the video input signal is interrupted. A flywheel synchronisation circuit, to provide drive pulses in the absence of a video signal at a nominal 50 Hz, would overcome this but, in practice, proved undesirable and was not incorporated.

The reason for this was that many video tapes were found to consist of short records separated by unrecorded sections and, in these cases, the automatic stop and start facility resulted in a saving of film, simplified subsequent film editing, and also gave a useful indication of any tape recorder malfunction.

### 6.5 Operation at different field rates

Because the input video field frequency determines the television scan duration and camera speed (hence exposure time), the correct relationship between them (once set for a 40 ms exposure time at 16 $\frac{2}{3}$  pictures per second at a field frequency of 50 Hz) will be maintained at other field frequencies.

Also as the start of the television vertical scan and the shutter opening time are synchronised by means of the shutter reference pulse, the correct camera shutter phase will also be maintained. The camera will therefore operate, without re-alignment, within the field frequency range of 45 Hz to 65 Hz.

### 7 RESULTS OBTAINED

The equipment has been used in most of the situations described in section 2 with considerable success, work being carried out for several RAE Departments and other MOD Establishments, in ground based and airborne roles with both colour and monochrome television systems.

### REFERENCE

<u>No</u>	<u>Author</u>	<u>Title, etc</u>
1	-	The CTR-2 and CTR-3 Colour Telefilm Recorders manufactured by:- Teledyne Camera Systems 131 North 5th Avenue Arcadia California 91006 USA

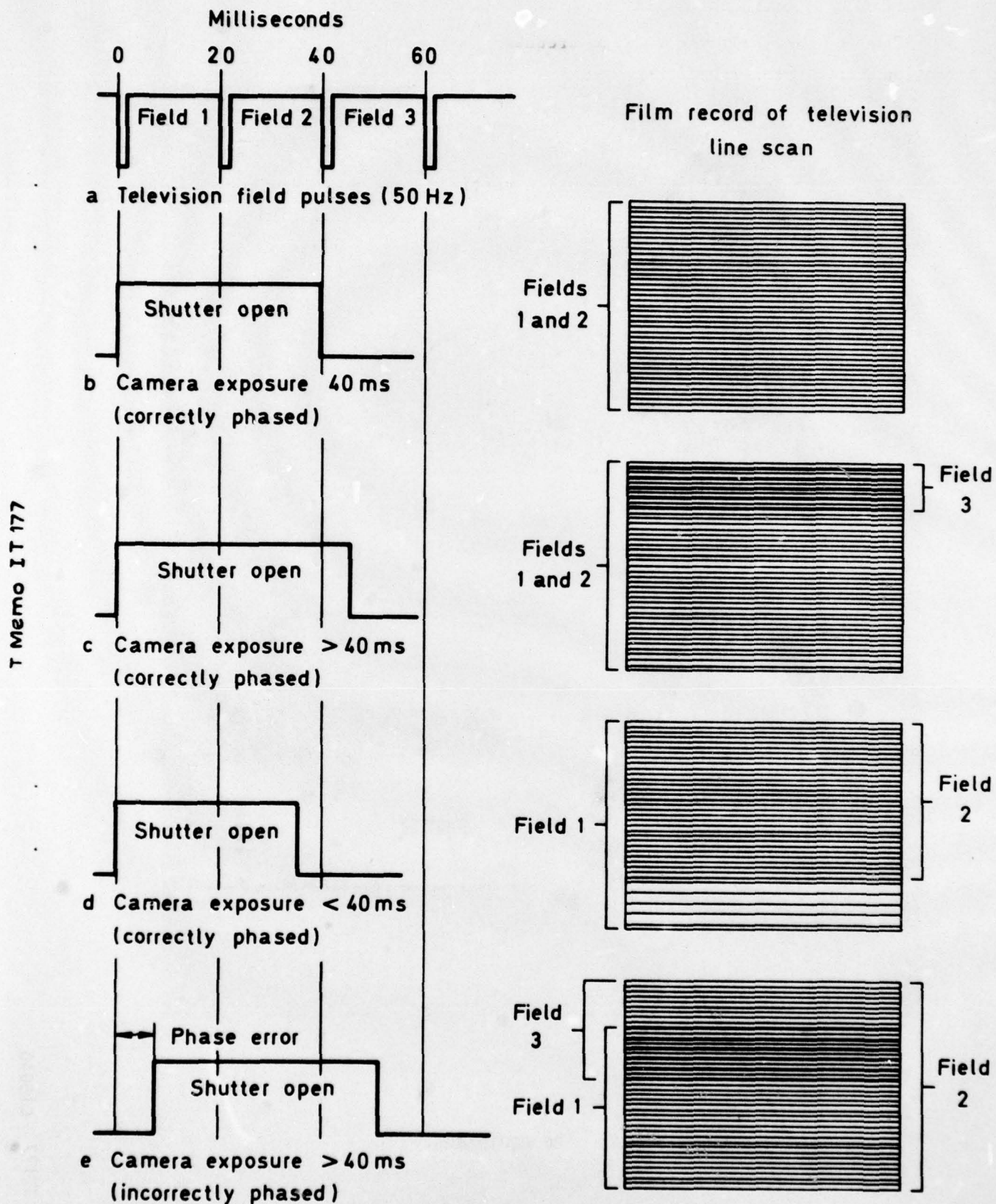

Fig 1 The effect of exposure time and phasing errors

Fig 2



Fig 2 The equipment.

Fig 3

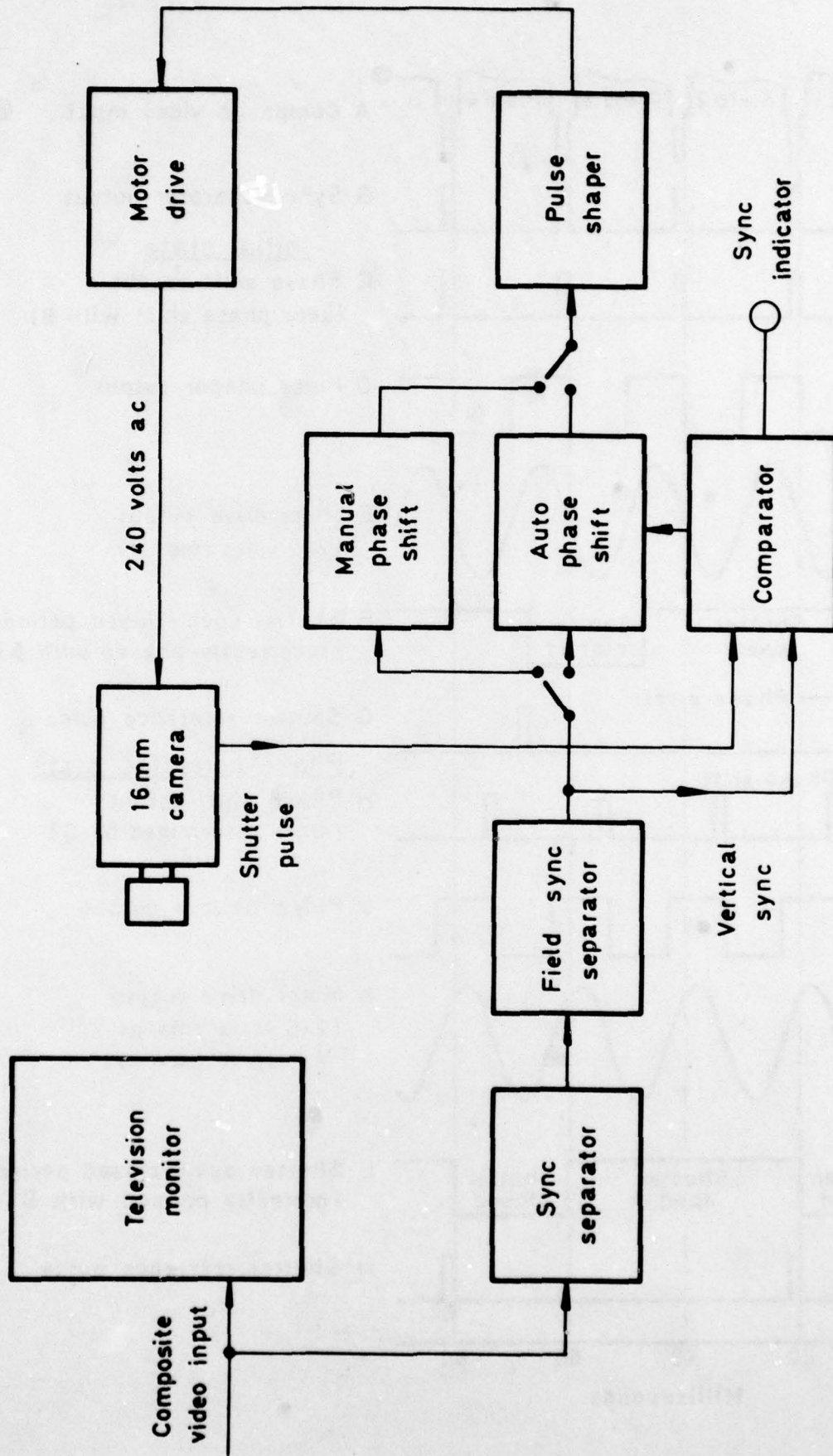

Fig 3 Schematic block diagram

Fig 4

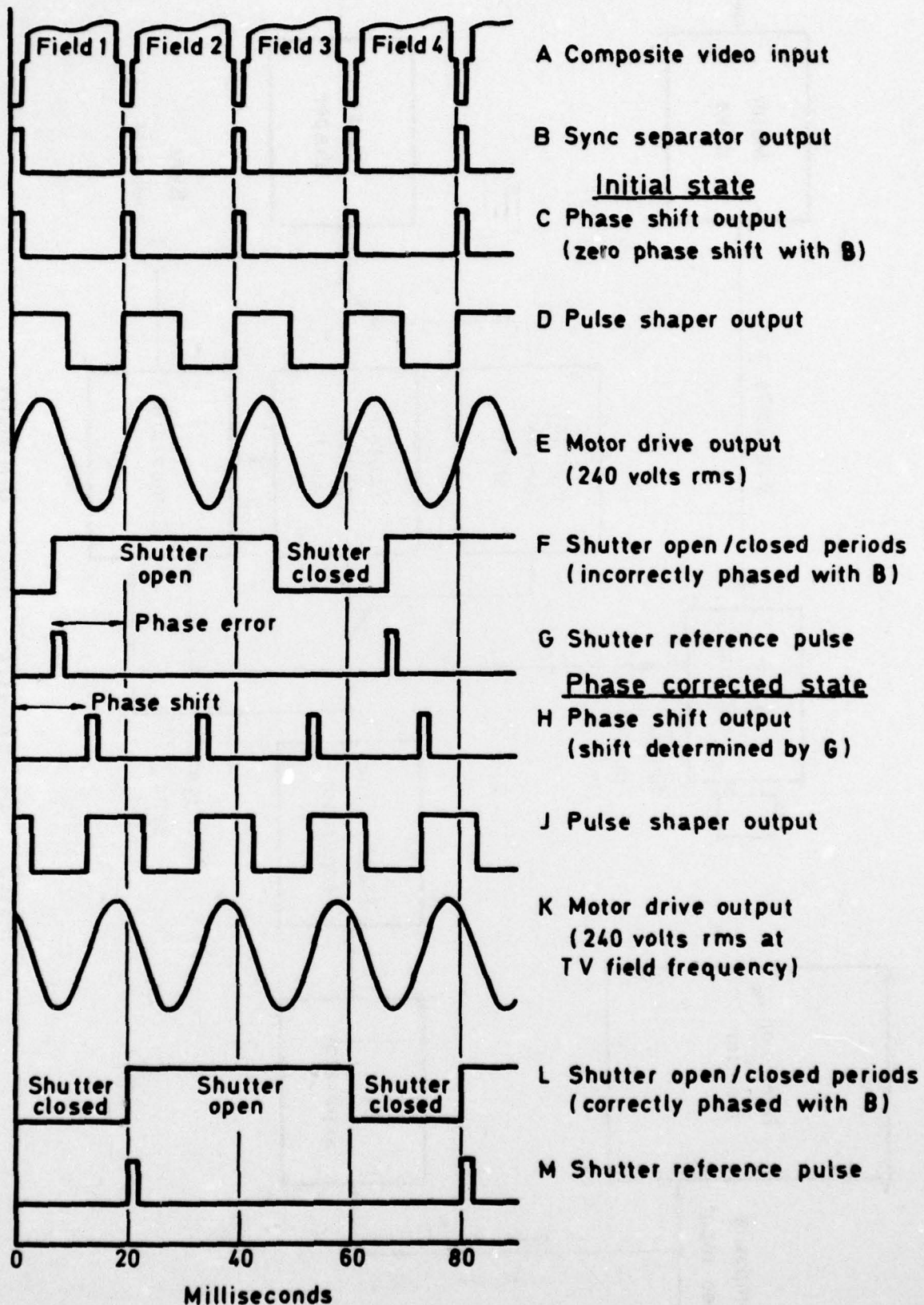

Fig4 Control unit waveforms

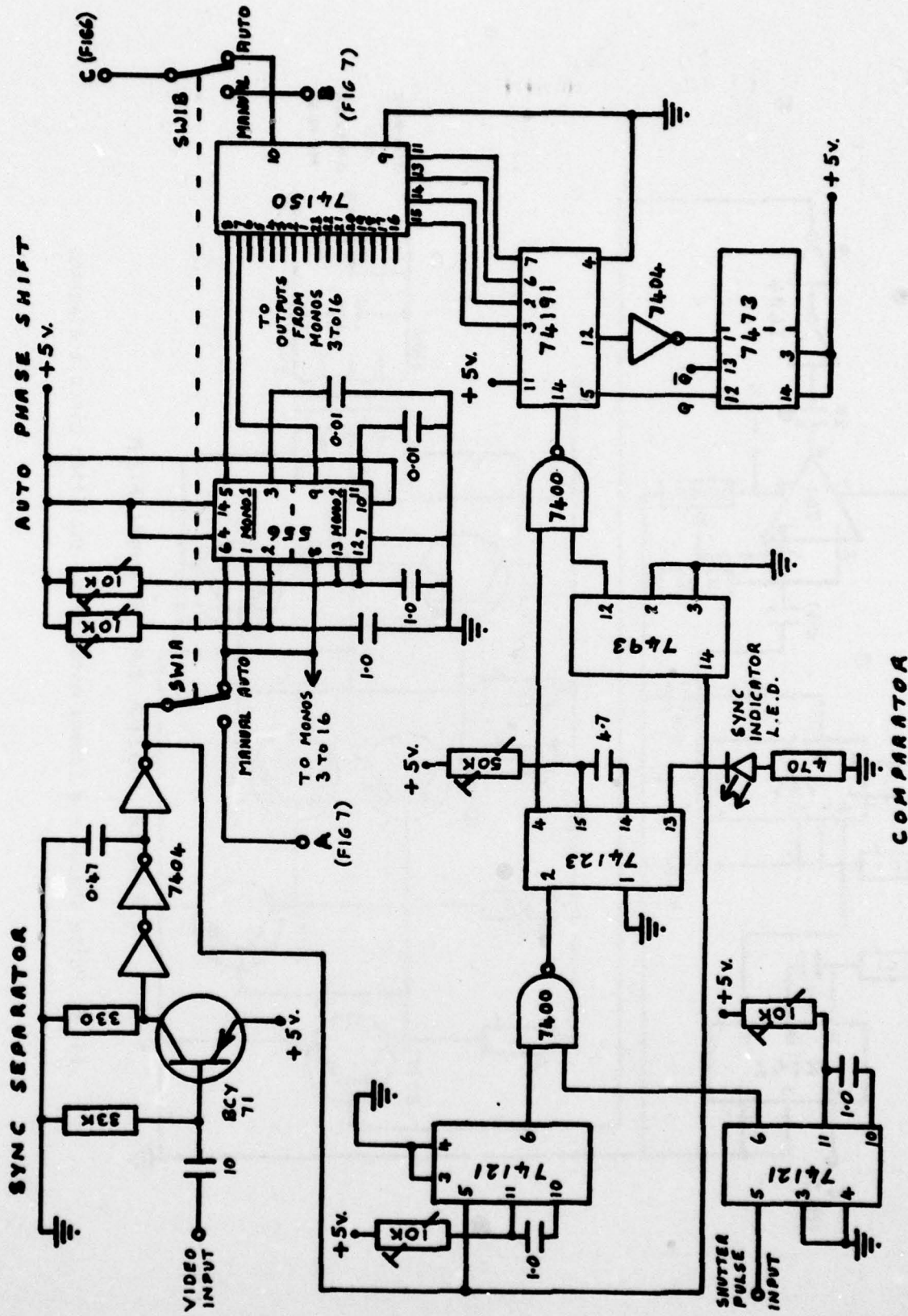

Fig 5

Fig 5 Sync separator, auto phase shift and comparator circuit diagrams

Fig 6

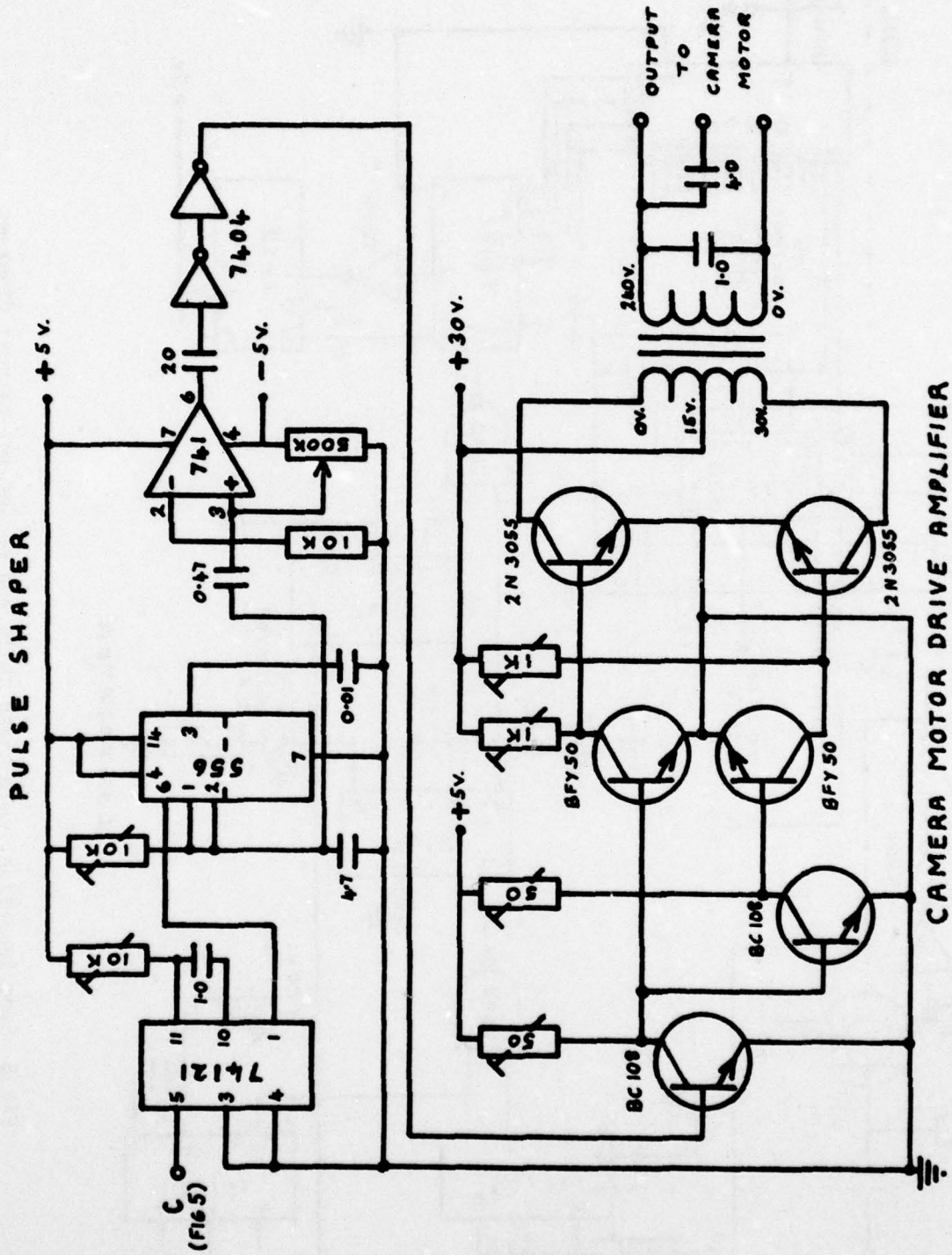
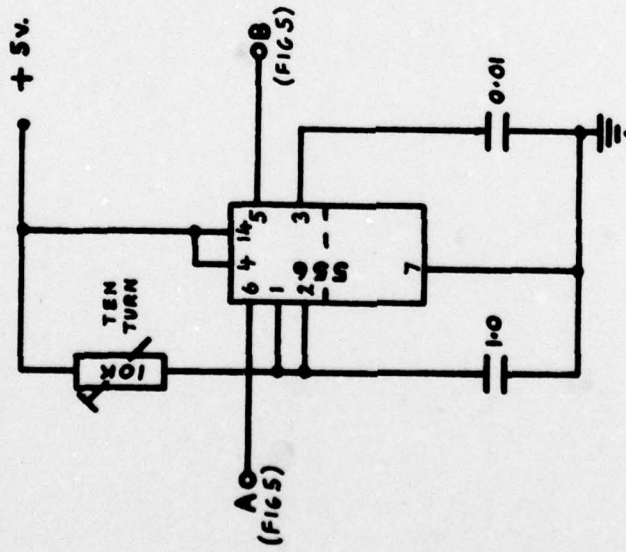
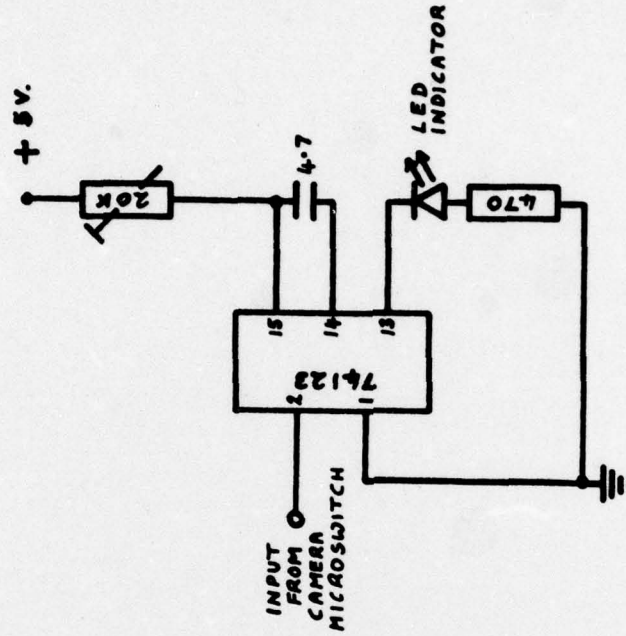

Fig 6 Pulse shaper and camera motor drive amplifier circuit diagrams



MANUAL PHASE SHIFT



FILM RUNOUT INDICATOR

Fig 7

Fig 7 Manual phase shift and film runout indicator circuit diagrams

**REPORT DOCUMENTATION PAGE**

Overall security classification of this page

**UNCLASSIFIED**

As far as possible this page should contain only unclassified information. If it is necessary to enter classified information, the box above must be marked to indicate the classification, e.g. Restricted, Confidential or Secret.

1. DRIC Reference (to be added by DRIC)	2. Originator's Reference <b>RAE TM IT 177</b>	3. Agency Reference <b>N/A</b>	4. Report Security Classification/Marking  <b>UNCLASSIFIED</b>
5. DRIC Code for Originator  <b>850100</b>	6. Originator (Corporate Author) Name and Location <b>Royal Aircraft Establishment, Farnborough, Hants, UK</b>		
5a. Sponsoring Agency's Code  <b>N/A</b>	6a. Sponsoring Agency (Contract Authority) Name and Location  <b>N/A</b>		
7. Title <b>An automatic portable telecine camera</b>			
7a. (For Translations) Title in Foreign Language			
7b. (For Conference Papers) Title, Place and Date of Conference			
8. Author 1. Surname, Initials <b>Humphreys, J.B.</b>	9a. Author 2 <b>Mitchell, P.J.</b>	9b. Authors 3, 4 .... <b>-</b>	10. Date   Pages   Refs. <b>Aug 1978   17   1</b>
11. Contract Number <b>N/A</b>	12. Period <b>N/A</b>	13. Project	14. Other Reference Nos. <b>-</b>
15. Distribution statement (a) Controlled by - <del>Class of Information - British Super, etc</del> (b) Special limitations (if any) -			
16. Descriptors (Keywords) <b>Video recording.</b> (Descriptors marked * are selected from TEST)			
17. Abstract  This Memorandum describes an automatic portable telecine system that enables television records to be transferred to 16 mm film for analysis or demonstration purposes.  A television display is filmed by a modified 16 mm cine camera driven by a control unit in which the camera supply voltage is derived from the field synchronisation pulses of the video signal.  Automatic synchronisation of the camera mechanism is achieved over a wide range of television field frequencies and the shutter bar effect, resulting from exposure time and camera speed errors in non-synchronised systems, is eliminated.			

F5910/1