

AD-A063 405

TELEPHONICS CORP HUNTINGTON N Y
ADVANCED SOLID STATE POWER CONTROLLER DEVELOPMENT, PHASE I. STU--ETC(U)
SEP 78 R J EDWARDS

F/G 10/2

F33615-77-C-2017

UNCLASSIFIED

AFAPL-TR-78-55

NL

1 OF 5

AD
A063405



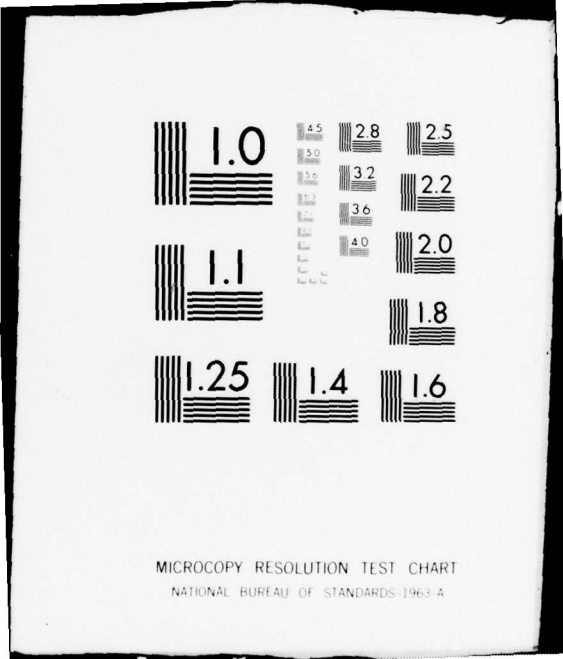

MICROCOPY RESOLUTION TEST CHART
NATIONAL BUREAU OF STANDARDS-1963-A

OK

AFAPL-TR-78-55

LEVEL II

2

AD A063405

**ADVANCED SOLID STATE POWER CONTROLLER
DEVELOPMENT
Phase I Study Report**

TELEPHONICS CORPORATION
770 PARK AVENUE
HUNTINGTON, NEW YORK 11743

DDC
RECEIVED
JAN 16 1979
C

DDC FILE COPY

SEPTEMBER 15, 1978

TECHNICAL REPORT AFAPL-TR-78-55
Interim Report for Period July 1977 - June 1978

Approved for public release; distribution unlimited.

AIR FORCE AERO PROPULSION LABORATORY
AIR FORCE WRIGHT AERONAUTICAL LABORATORIES
AIR FORCE SYSTEMS COMMAND
WRIGHT-PATTERSON AIR FORCE BASE, OHIO 45433

79 01 15 059

NOTICE

When Government drawings, specifications, or other data are used for any purpose other than in connection with a definitely related Government procurement operation, the United States Government thereby incurs no responsibility nor any obligation whatsoever; and the fact that the government may have formulated, furnished, or in any way supplied the said drawings, specifications, or other data, is not to be regarded by implication or otherwise as in any manner licensing the holder or any other person or corporation, or conveying any rights or permission to manufacture, use, or sell any patented invention that may in any way be related thereto.

This report has been reviewed by the Information Office (OI) and is releasable to the National Technical Information Service (NTIS). At NTIS, it will be available to the general public, including foreign nations.

This technical report has been reviewed and is approved for publication.

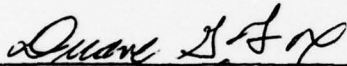

DUANE G. FOX
Project Engineer
Electrical Systems
Vehicle Power Branch

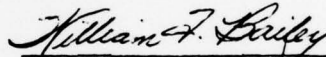

WILLIAM F. BAILEY, MAJOR, USAF
Chief, Vehicle Power Branch

FOR THE COMMANDER

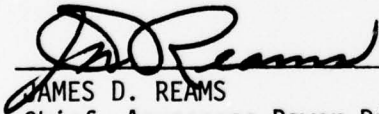

JAMES D. REAMS
Chief, Aerospace Power Division

"If your address has changed, if you wish to be removed from our mailing list, or if the addressee is no longer employed by your organization please notify AFAPL/POP, W-PAFB, OH 45433 to help us maintain a current mailing list".

Copies of this report should not be returned unless return is required by security considerations, contractual obligations, or notice on a specific document.

UNCLASSIFIED

SECURITY CLASSIFICATION OF THIS PAGE (When Data Entered)

19 REPORT DOCUMENTATION PAGE		READ INSTRUCTIONS BEFORE COMPLETING FORM	
1. REPORT NUMBER 18 AFAPL-TR-78-55	2. GOVT ACCESSION NO.	3. RECIPIENT'S CATALOG NUMBER	
4. TITLE (and Subtitle) 6 ADVANCED SOLID STATE POWER CONTROLLER DEVELOPMENT, PHASE I, STUDY REPORT.	9	5. TYPE OF REPORT & PERIOD COVERED Interim Technical Report, 15 July 1977 - 15 June 1978	
		6. PERFORMING ORG. REPORT NUMBER	
7. AUTHOR(s) 10 R. J. Edwards	15	8. CONTRACT OR GRANT NUMBER(s) F33615-77-C-2017 (new)	
9. PERFORMING ORGANIZATION NAME AND ADDRESS ISC Telephonics 770 Park Avenue Huntington NY 11743	16	10. PROGRAM ELEMENT, PROJECT, TASK AREA & WORK UNIT NUMBERS 31452951 17 29	
		12. REPORT DATE 15 Sep 1978	
11. CONTROLLING OFFICE NAME AND ADDRESS Air Force Aero Propulsion Laboratory (PO) AF Wright Aeronautical Laboratories, AFSC Wright-Patterson AFB OH 45433	11	13. NUMBER OF PAGES 383	
14. MONITORING AGENCY NAME & ADDRESS (if different from Controlling Office) 12 391p.		15. SECURITY CLASS. (of this report) Unclassified	
		15a. DECLASSIFICATION/DOWNGRADING SCHEDULE	
16. DISTRIBUTION STATEMENT (of this Report) Approved for public release; distribution unlimited.			
17. DISTRIBUTION STATEMENT (of the abstract entered in Block 20, if different from Report)			
18. SUPPLEMENTARY NOTES			
19. KEY WORDS (Continue on reverse side if necessary and identify by block number) Aircraft Electrical Systems Power Controller Solid State Power Controller Aircraft Power Distribution AC Power Controller Cost Reduction DC Power Controller			
20. ABSTRACT (Continue on reverse side if necessary and identify by block number) This report documents the results of Phase I of a two phase program to develop a low cost solid state power controller for USAF aircraft. This study investigated various packaging and interface concepts for solid state power controllers. Trade Studies considered cost, complexity, environmental performance, reliability, and maintainability. The impact of the power controller configuration on the aircraft electrical system was determined. Recommendations on three power controller breadboards to be			

DD FORM 1 JAN 73 1473 EDITION OF 1 NOV 65 IS OBSOLETE

UNCLASSIFIED

SECURITY CLASSIFICATION OF THIS PAGE (When Data Entered)

79 01 15 033 345 500

mk

UNCLASSIFIED

SECURITY CLASSIFICATION OF THIS PAGE(When Data Entered)

fabricated in Phase II are made. They include a single phase 5 amp 115 VAC, 3-Phase 5 amp 115 VAC, and 5 amp 28 VAC.

UNCLASSIFIED

SECURITY CLASSIFICATION OF THIS PAGE(When Data Entered)

FOREWORD

This interim technical report was submitted by ISC Telephonics in June 1978 under Contract F336125-77-C-2017. The effort was sponsored by the Air Force Aero Propulsion Laboratory, Air Force Wright Aeronautical Laboratories, Wright-Patterson AFB OH, under Project 3145, Task 314529, and Work Unit 31452951, "Advanced Solid State Power Controller Development". G. Altemose of ISC Telephonics was the Project Manager and was technically responsible for the work. The report was prepared by R. J. Edwards. The work reported herein was performed during the period of July 1977 through June 1978.

Douglas Aircraft Company and The Vought Corporation were subcontracted to provide pertinent characteristics, design and safety criteria and cost information. This study effort began in November 1977 and was concluded in March 1978.

Douglas submitted a Study Report (MDC J7894) for Phase I, contained in Appendix A, per Telephonics P.O. No. 62878. Vought submitted a Study Report (2-54100/8R-51510) for Phase I, contained in Appendix B, per Telephonics P.O. No. 62878.

ACCESSION	
NTIS	<input type="checkbox"/>
DDC	<input type="checkbox"/>
UNANNOUNCED	<input type="checkbox"/>
JUL 1978	
BY	
DEPARTMENT OF DEFENSE	
A	

CONTENTS

<u>Paragraph</u>		<u>Page</u>
Section I	INTRODUCTION AND SUMMARY	
1.1	Introduction	1
1.2	Summary	2
1.2.1	Summary of the Douglas Interim Report	4
1.2.2	Summary of the Vought Interim Report	5
Section II	TRADE STUDIES	
2.1	System Design	7
2.2	Pass Section Trade Study	7
2.2.1	Pass Elements	9
2.3	FET's	11
2.4	GTO's	11
2.5	TRIAC's and SCR's	12
2.6	Bipolar Transistors	12
2.7	Summary	13
2.8	Pass Section Configuration	17
2.8.1	Zero Voltage Turn On and Zero Current Turn Off	20
2.9	Pass Element Driver	29
2.9.1	Transistors	29
2.9.2	SCR's	32
2.9.3	Recommended Drive Circuit	33
2.10	Fuse and Load Compatibility	34
2.11	Control Input/Output	38
2.12	Internal Power Supply	42
2.13	Status Monitor	50
2.14	Output Shunt (Safety)	54
2.15	Current Sensor	57
2.16	Applicability to DC SSPC	59
2.16.1	Overload Protection Considerations	62
2.16.2	DC SSPC (1000%) Instant Trip Approach	63
2.17	Current Limiting Approach	65
2.18	LSI vs Universal Monolithic Arrays vs. Hybrids vs. Discrete Component Technology	68
2.18.1	General	68
2.18.2	Universal Standard Monolithic Arrays	68
2.18.3	Discrete Components	69
2.18.4	Hybrids	70
2.19	Three Phase SSPC Units	71
2.19.1	Three Phase Bias Transformer and Power Supply Configuration	77
2.20	Trip Circuits	77
2.21	Load Compatibility	89
2.21.1	Capacitor Loads	90
2.21.2	Capacitor Input Filter Power Supplies	90

CONTENTS (Cont)

<u>Paragraph</u>		<u>Page</u>
2.21.3	Inductive Loads	92
2.21.4	Lamp Loads	93
2.21.5	Motor Loads	95
2.21.6	Half Wave Loads	96
2.21.7	Electro-Explosive Devices (EED)	96
2.21.8	Coordination of Cascaded Power Controllers	97
2.21.9	Repetitive Pulsed Loads	97
Section III	PROPOSED DESIGN AND SYSTEM CONFIGURATION	
3.1	Alternate SSPC System Configurations	102
3.2	Solid State Power Controller Module Construction	102
3.3	Weight Considerations	104
3.4	Structural Dynamics	104
3.5	Solid State Power Controller Load Center	105
3.6	Thermal Considerations	110
APPENDIX A	DOUGLAS AIRCRAFT COMPANY PHASE 1 REPORT	
APPENDIX B	VOUGHT CORPORATION PHASE 1 REPORT	

LIST OF ILLUSTRATIONS

<u>FIGURE</u>	<u>TITLE</u>	<u>PAGE</u>
1	Single SSPC Sytem Block Diagram	8
2	Pass Section Configuration	18
3	Control ON/Off Timing	21
4	Typical HFE Characteristic Curve	31
5	Recommended SCR Driver Circuit	33
6	Recommended Transistor Driver Cirucit	34
7	Load Center Locations	35
8	Internal Power Supply Schematic	45
9	Zener Regulated Power Supply	46
10	Dissipative Series Regulator	49
11	Switching Regulator	49
12	Output Status Circuit for Load Voltage Monitoring	52
13	10% Load Current Status Monitor for Transistor Pass Section	52
14	Load Current Status Monitor for SCR Pass Section	53
15	Block Diagram of Output Shunt	55
16	Block Diagram of DC SSPC	60
17	Ringing Choke DC-To-DC Converter	61
18	Push Pull DC-DC Converter	61
19	DC SSPC Current Limit Characteristics	62
20	Pass Section DC SSPC Current Limit Approach	64
21	Equivalent Circuit of DC SSPC Pass Section	65
22	AC SSPC Current Limit Approach Hybrid	67
23	Three Phase Waveforms	74
24	Simple "Y" Configuration	75
25	Alternate Circuit Configuration Using Less Complex Pass Section and Timing Circuit	76
26	Bias Transformer and Power Supply Configuration for 3 Phase Operation	78
27	Full Wave Power Supply as Load for SSPC	82
28	Block Diagram of Typical Analog Time Trip Circuit	84
29	Block Diagram of Typical Digital Time Trip Circuit	85
30	Single Phase Line Operated Switching Regulated Power Supply	91
31	Three Phase Line Operated Switching Regulated Power Supply	91
32	Transistor Current and Voltage Waveforms During Instant Trip	94
33	Cascading SSPC's for Protection of Several Small Loads	98
34	Typical Load Center	107

SECTION I
INTRODUCTION AND SUMMARY

1.1 INTRODUCTION

The objective of this study program is to establish and validate new concepts in the electrical and mechanical design of solid state power controllers used in EMUX systems. This study includes trade off analysis and circuit configurations applicable to SSPC's mounted in individual containers and on printed circuit cards, including single phase, multiple load SSPC's and three phase SSPC's. A functional block diagram of custom MSI chips universally adaptable for the various SSPC circuit configurations is established.

Section II contains the SSPC circuit analysis and trade studies performed by Telephonics. Section III contains proposed SSPC system configuration and recommendations from data evaluated in Section II and Appendices A and B.

Appendix A contains the interim report from Douglas Aircraft Company and Appendix B contains the interim report from the Vought Corporation. They provided pertinent characteristics of the aircraft power systems and proposed load centers. This ensures the specification of realistic requirements for the SSPC'S. Douglas Aircraft Company was selected as a team member in this study for their expertise in the overall requirements of aircraft electrical and power management systems. In addition to the Telephonics/Douglas team, the Vought Corporation provided, under a subcontract agreement, the specialized capabilities in the area of electrical systems and EMUX requirements unique to fighter aircraft.

1.2 SUMMARY

The SSPC provides the on/off control and overload protection function traditionally handled by a relay/circuit-breaker combination. It has the advantages of small size, low weight and high reliability associated with solid state devices.

The SSPC will enable reduced power distribution system bus length and weight, achieved by placing the SSPC's near loads and employing remote low voltage multiplexed control signals. Loads are activated only at zero voltage points and deactivated at zero current points for elimination of switching transients and EMI problems.

The SSPC also provides increased reliability and chatter free operation due to the use of solid state rather than mechanical components. This is of special importance for the high vibration level environments encountered on aircrafts. The overall functional requirements of the SSPC are to permit on/off control of the power to a load while providing protection for the aircraft wiring against shorts and other high current abnormalities. A fail safe fuse is included in case a short occurs and a component failure prohibits turn-off of the SSPC. The SSPC will also properly interface with a multiplexed power management system (EMUX). This includes isolation between the control and BIT circuits.

Low cost and high reliability are achieved by using MSI/hybrid construction techniques.

Monolithic array integrated circuit chips containing the timing, logic function, load current trip amplifier and preliminary drive circuits, that can be adapted for use with either a transistor or SCR pass section, are proposed. The monolithic array device is a special custom made LSI/MSI integrated circuit which can be utilized for different types of power controllers.

The circuitry is partitioned into functional blocks which individually could be used as needed in the various configurations, 1 ϕ , 3 ϕ , AC, DC, etc. This would lower cost since production quantities would be increased.

The proposed SSPC design provides low "on" power dissipation by minimizing the drive requirements for the power elements, using VMOS FET drivers and the load current itself for drive current.

In order to maintain compatibility with all kinds of loads the proposed SSPC will utilize instant trip rather than current limiting. Above 1000% overload the proposed SSPC will current limit and "instant trip". This will maintain compatibility with stiff power generators and minimize the energy requirements for the fail safe fuse supplied with the SSPC. In addition, the pulsed energy supplied to the load is also minimized.

Full cycle control will be used (turn on and turn off at the same point in the cycle). This will eliminate the possibility of saturating inductive loads and causing nuisance trips. Also to maintain

load compatibility and proper dynamic characteristics, large in-rush currents up to 1000% without tripping the SSPC will be allowed.

A two wire system is proposed to minimize the number of wires supplying command and operating status between the SSPC and the EMUX system.

In addition to the configuration proposed above, two other SSPC configurations are recommended for design, fabrication and evaluation in Phase II of this study program. These are a DC SSPC and a 3Ø, 4 wire SSPC, both described in Section II of this report. The proposed ratings are 5 amps, 400 Hz, 115 VAC for the AC SSPC'S and 5 amps for the 28 volt DC SSPC.

1.2.1 SUMMARY OF THE DOUGLAS INTERIM REPORT

The Douglas interim report provided background information and trade-studies on large frame aircraft load types and distribution, location of the load management centers and a comprehensive analysis of the normal steady-state and fault currents available from large aircraft power systems. The aircraft (C15-model) power system requirements were specified as 115/200V, 3 phase, 400 Hz and 28 VDC conforming to MIL-STD-704B. It was also specified that the power management system (EMUX) must have sufficient redundancy to accept two failures without terminating primary power. SSPC operational requirements, safety and environmental requirements were outlined in the report. The ambient temperature for the SSPC's and associated circuits was given as -40°C to $+49^{\circ}\text{C}$ and is much

less stringent than that given for fighter aircraft (-55°C to +125°C).

The electrical load analysis revealed that the ampere rating requirements ranged from 0.5A to 200A. Power controllers with ratings from 15A to 200A are expected to be RCCB's.

The electrical system fault current analysis showed that fault currents of approximately 1600 amps from a 3Ø power bus and 1200 amps from a 1Ø power bus are available for the first quarter of a cycle during a short circuit condition and 750 amps for several cycles for both 1Ø and 3Ø power buses. The availability of such large fault currents suggests that SCR SSPC's would require some form of current limiting to reduce peak currents for reliable operation.

1.2.2 SUMMARY OF THE VOUGHT INTERIM REPORT

The Vought Interim Report provided background information, design criteria, using the A-7D aircraft as a model, for SSPC trade-studies as related to military aircraft. Among the SSPC application factors presented were the aircraft bus characteristics, SSPC Input/Output interface requirements, SSPC thermal considerations, SSPC cost factors and single channel SSPC module configuration along with the load management center. Also given was the load characterization for electro-explosive devices (EED), lamps, motors and transformers. Tests at Telephonics indicate that the high in-rush currents specified for lamps (up to 28 times the steady-state) will be reduced by a factor of 4 by using zero voltage turn on

(ZVTO). Also, that the back EMF generated when turning off motor loads has considerably less energy to be fed back to the SSPC or other loads when zero current turn off (ZCTO) is used. The ambient temperature specified (-54°C to $+125^{\circ}\text{C}$) along with a heatsink surface temperature of 120°C poses severe problems with components designed to operate at a maximum of $+125^{\circ}\text{C}$, since an extremely low thermal resistance must be achieved in a very small package.

SECTION II
TRADE STUDIES

2.1 SYSTEM DESIGN

A general functional block diagram of the SSPC is shown in Figure 1. The blocks apply to all types of single phase SSPC's. Three phase power controllers would utilize the same building blocks in a different configuration.

The on/off control signal from the EMUX demultiplexer is sent to an input circuit which is isolated from the control and pass section. It includes the filtering incorporated to provide noise immunity and minimize false turn on's. The control block includes the generation of the trip curve as well as the preliminary drive circuitry for the pass section. It accepts the current sensor output which is used to determine when the trip level is exceeded. An AC signal from the transformer in the internal power supply is used to synchronize to the voltage waveform. The control block also generates the status signal based upon receipt of the full voltage or 10% load current signals from the main power path. The control block supplies an isolated signal for the output circuits which provide status and trip information back to the EMUX terminal.

The pass section includes the main power section, which uses either transistors or SCR's.

2.2 PASS SECTION TRADE STUDY

The two most significant considerations affecting the design of the pass section are selection of the pass element and the circuit

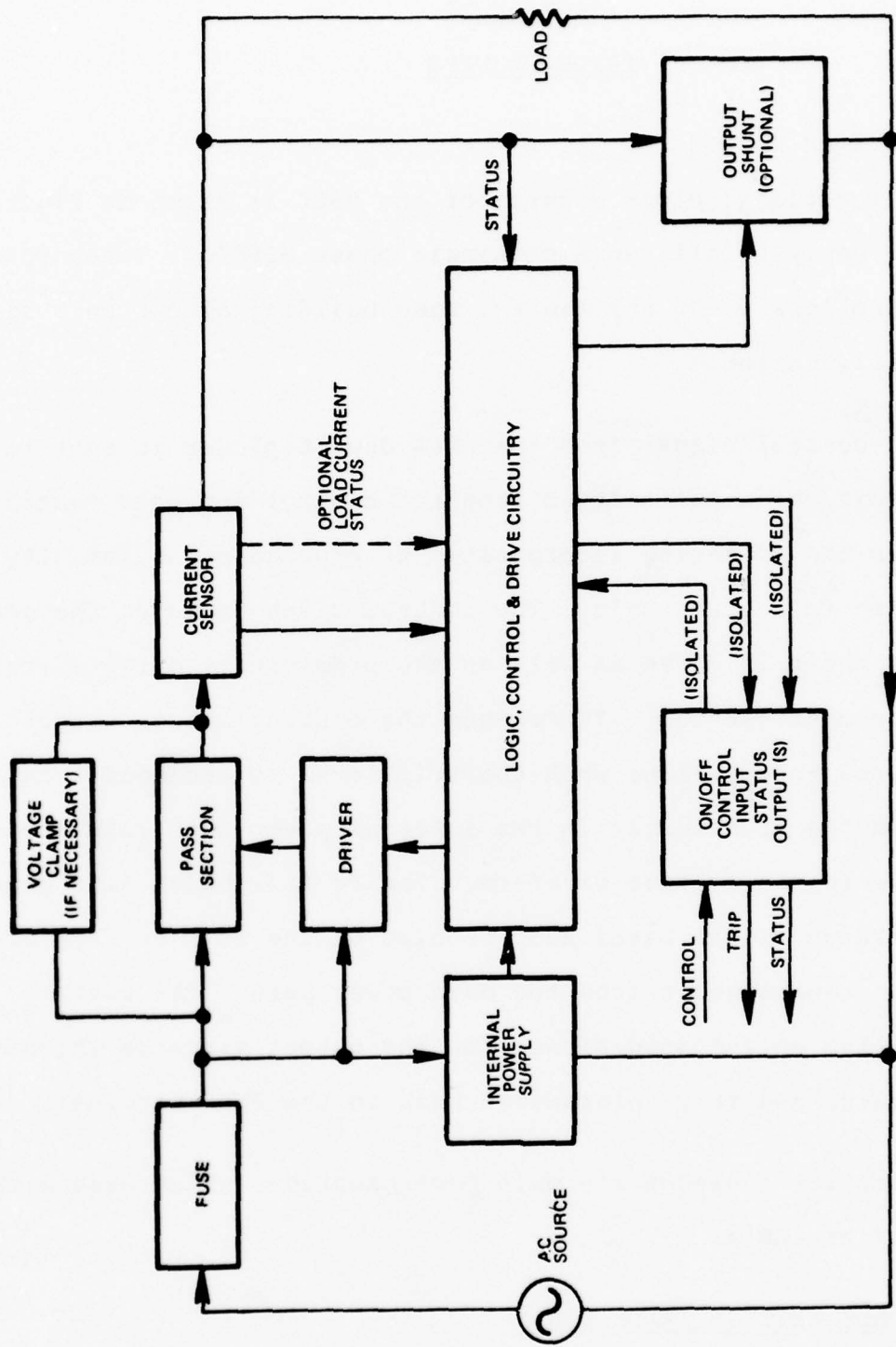

Figure 1. Single SSPC System Block Diagram

configuration. At least two elements (transistor and SCR), and several configurations offer attractive features. However, even the best possible pass section in today's state-of-the-art is far from ideal, and a number of compromises must be accepted. An acceptable design of a reasonable pass section should have the following desirable characteristics:

- a. Low leakage current in OFF state
- b. Low voltage drop in ON state
- c. Simplicity of drive circuit
- d. High voltage, current, and energy capability
- e. Insensitivity to transients from both source and load
- f. Load compatibility
- g. Small size
- h. Minimum number of components
- i. Low probability of failure causing half-waving

2.2.1 PASS ELEMENTS

The following elements were considered for pass elements:

- a. Transistor (bipolar)
- b. SCR
- c. Triac
- d. GTO (SCR with gate-turn-off)
- e. FET

The advantages and disadvantages of each device were examined and the results are shown in Table 1.

Table 1. Pass Section Trade Study

DEVICE PARAMETER	TRANSISTORS	SCR'S	TRIAC'S	GTO'S	FET'S
LEAKAGE CURRENT @ 125°C	0.1 TO 2 MA	2 MA TO 17 MA	2 MA TO 15 MA	2 MA @ 25°C	0.5 MA @ 25°C
SATURATION VOLTAGE IC MAX	0.5V TO 2.5V	2.0V	1.6V TO 2.15V	3.3V	1.6V TO 10V
STORAGE TIME	0.6 US TO 15 US	15 US TO 40 US (TURN OFF TIME)	-----	1 US TO 10 US (TURN OFF TIME)	8 NS
FALL TIME	0.1 US TO 15 US	-----	-----	-----	8 NS
RISE TIME	0.5 US TO 2.0 US	1 US (TURN ON TIME)	0.1 US TO 2 US (TURN ON TIME)	-----	8 NS
SECONDARY BREAKDOWN DC LIMIT	5A @ 50V	-----	-----	-----	N/A
PULSED ENERGY	0.15J TO 6 JOULES	-----	-----	-----	-----
HOLDING CURRENT	-----	.008A TO 0.5A	.05A TO .85A	.005A TO 80 MA	-----
BLOCKING VOLTAGE	80V TO 600V	100V TO 1200V	200V TO 1200V	50V TO 600V	90V TO 400V
CONTINUOUS CURRENT	10A TO 80A	7.4A TO 125 ARMS	10A TO 200 ARMS	4A TO 8.5A	2A TO 5 AMP
PEAK CURRENT	15A TO 120A	2085A (NON-REPET)	UP TO 2280 (NON-REPET)	UP TO 100A (NON-REP)	3A TO 10 AMP
DRIVE CURRENT	0.1A TO 24A (HFE 5 TO 150)	.03A TO 0.3A	.03A TO 0.8A	ON: 1 MA TO 160 MA OFF: V _{GO} = -70V Z _G = 1Ω	100 MA - PULSE 2 MA - CONTINUOUS
POWER DISSIPATION 25°C CASE	140W TO 350W	-----	-----	UP TO 50 WATTS	25W TO 125W
THERMAL RESISTANCE JUNCT CASE	0.5°C/W TO 1.2°C/W	0.4°C/W TO 3.1°C/W	.15°C/W TO 3.1°C/W	TO 2°C/W	1°C/W @ +150°C/W
OPERATING TEMPERATURE	-65°C TO +200°C	-65°C TO +150°C (40 TO +125 FOR MOST HIGH CURRENT SCR'S)	-40°C TO +125°C	-40°C TO +125°C	-55°C TO +150°C
STORAGE TEMPERATURE	-65°C TO +200°C	-65°C TO +150°C	-40°C TO +125°C	-40°C TO +125°C	-55°C TO +150°C

2.3 FETS

Presently power VMOS FETS are available in blocking voltages up to only 90V with current ratings of 3A peak (2A continuous). These devices are rated at 25 Watts maximum and 5°C/W thermal resistance junction-to-case. In the 3rd Quarter of 1978, higher power devices will be available. These devices will be rated at 200V and 400V with maximum pulsed drain currents of 10 Amp and 5A respectively. The maximum power dissipation allowed is 125 Watts with 1°C/W thermal resistance junction-to-case. The maximum junction temperature is limited to 150°C for both operating and storage. The saturated resistance drain to source (RDS) is quite high when compared to bipolar transistors. The 400V, 5 Amp VMOS power FET is 1.5Ω typically and 2Ω maximum measured at $I_D = 1$ Amp. The devices have no secondary breakdown derating and are not thermally limited. They will directly interface to CMOS, TTL, DTL and MOS logic circuits.

VMOS FETS are recommended for use as a driver for both the SCR and transistor pass sections because almost no power is required to drive them.

2.4 GTO's

Gate Turn Off devices (Gate Controlled SCR) operate at much lower cathode current densities to ensure that gate control can be maintained to turn the device off. Therefore, for high currents since paralleling is necessary, the GTO is not economical when compared to high current, high voltage transistors. The saturation of GTO devices is higher than comparable transistor devices by a 2 to 1 factor. The maximum current rating of current standard devices

are 8.5A rms (RCA G5000 Series). The turn off circuitry for a GTO device must supply very high peak current (gate source impedance $\approx 1\Omega$) at high negative voltage, for example -70V at 8.5 peak.

The typical DC holding current for a 8.5A device is 500MA (800 mA maximum).

2.5 TRIACS & SCR's

SCR and TRIAC devices are available with current ratings up to 200 Amps and blocking voltages up to 1200V. For 400 Hertz operation higher commutating capability (di/dt and dv/dt) is required. In order to achieve proper commutation with certain inductive loads, the dv/dt must be limited by a series RC circuit across the devices. RC networks or snubber circuits increase off state leakage current. The resistor and capacitors in the snubber circuit are usually physically large for voltage (>peak line) and power ratings, making it difficult for hybrid packaging.

If the device breakover voltage (V_{BO}) is exceeded, even by a short transient, a triac device will switch to the conducting state. This could have undesirable or hazardous results on the circuit being controlled, thus transient suppression is required.

2.6 BIPOLAR TRANSISTORS

Power transistors are available that will meet all desirable pass section characteristics. Units are available with very high current and voltage capabilities that are suitable for SSPC's up to 10 Amps. Low $V_{CE(sat)}$ can be obtained from single diffused devices,

however substantial base drive is usually required. Triple diffused Darlington's reduce base current drive requirements but VCE (sat) is 2 to 3 times higher than the single diffused devices. $E_{S/B}$ and $I_{S/B}$ requirements imposed by the circuit must be carefully defined, tested and specified for the device chosen. For example: If a transistor is allowed to dissipate energy in the VCE (sustaining) region, the manufacturer of the transistor should screen devices (at least on an AQL sample if not 100%) for this capability. Power transistors are available that will dissipate up to 6 joules of energy; however, most triple diffused devices mounted in a T0-3 case will handle only a few hundred millijoules.

When it is desirable to prevent the pass transistor from ever going into the sustaining region, some type of voltage clamp circuit or device must be used. Suitable voltage clamps are spark-gaps and power zeners (TransZorbsTM) with energy dissipating capabilities from 1.5 to 60 joules.

2.7 SUMMARY

The primary advantages and disadvantages of these devices are summarized as follows:

TRANSISTORS

Advantages

- a. Provide current limiting for faults.

Disadvantages

- a. Maximum current limited to approximately 40 amps rms. (Single unit devices can be paralleled.)

TRANSISTORS (Cont)

Advantages

- b. Can be turned off in mid-cycle, thereby facilitating selection of fail-safe fuse and minimization of energy transfer to words.
- c. Non-regenerative device, not subject to spurious turn-on from line transients.
- d. Low OFF state leakage current.
- e. Low ON state forward voltage drop.

Disadvantages

- b. Peak energy limited to several joules.
- c. High base drive needed for high collector currents. (This base drive can be supplied by a power VMOS FET)

SCR's

Advantages

- a. High voltage, current, and energy capability.
- b. Can be used in simple back-to-back configuration.

Disadvantages

- a. Cannot limit fault currents.
- b. Susceptible to nuisance turn-on due to $\frac{dv}{dt}$ limitations.
- c. Possible turn-on and turn-off problems with inductive loads.

SCR's (Cont)

Advantages

Disadvantages

- d. Inability to turn off in mid-cycle makes fail-safe fuse difficult to design and it permits a relatively large energy pulse to be applied to the load.
- e. Possible SCR damage due to $\frac{di}{dt}$ limitation.

TRIACS

Advantages

Disadvantages

- a. Only one device needed for AC operation
- a. Same as SCR, with more severe $\frac{dv}{dt}$ limitation.
Larger snubber networks required to prevent nuisance turn-on.

GTO's

The GTO is an SCR, with the capability of being turned off by applying a large negative voltage to the gate. However, at large currents, the required turn-off voltage becomes extremely high (near 100 volts). For very large currents, approaching the current rating of the GTO device, it cannot be turned off by any gate

voltage. Thus, for large currents, the GTO offers no advantage over the SCR.

FET's

Advantages

- a. Control is by voltage, rather than current, greatly simplifying the drive circuit requirements.
- b. No secondary breakdown.
- c. No offset voltage

Disadvantages

- a. Voltage rating limited to 200 volts, which is not adequate. (400 devices are expected late 1978.)
- b. Current limited to 2 amps, which is not adequate. (5 amp devices are expected late 1978.)

From these characteristics, a number of conclusions are evident:

- a. The FET is clearly unsuitable as the main pass element. However, it will be shown that the FET deserves serious consideration as a predriver for the main pass element.
- b. The GTO offers no real advantage over the conventional SCR at this time.
- c. The advantages of the TRIAC (single unit, ease of triggering) do not appear to outweigh the disadvantage (more severe $\frac{dv}{dt}$ problem), with respect to the SCR. That is, two

SCR's in a back-to-back configuration appear to be favored over a single TRIAC.

2.8 PASS SECTION CONFIGURATION

The four basic pass section configurations are shown in Figure 2. Many other configurations are conceivable, but experience has shown that these have the best combination of features. A brief trade study of these configurations is shown in Table 2. The configurations are shown in their most elementary forms, without base drive, gate drive, current sensing resistors, or other secondary requirements, which are discussed later.

The substantial power loss appears to be adequate reason for eliminating the full-wave approaches from consideration, for the 5 ampere unit. These losses are as follows:

	<u>Voltage</u>	<u>Power</u>
FW Transistor	2.4V	12.0W
BTB Transistor	1.7V	8.5W
FW SCR	2.9V	14.5W
BTB SCR	1.5V	7.5W

Thus, if transistors are used, full-wave requires an extra 3.5 watts, and if SCR's are used, full-wave requires an extra 7 watts.

FULL-WAVE

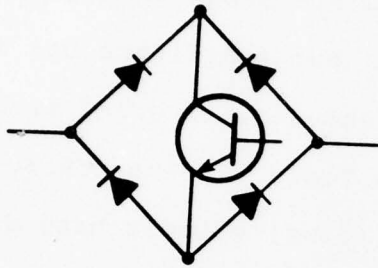

FULL-WAVE TRANSISTOR

BACK-TO-BACK

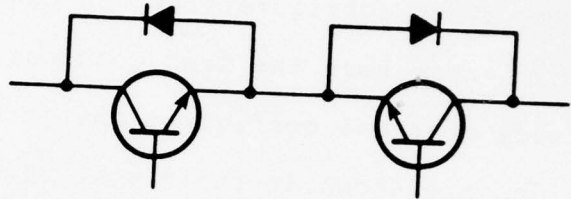

BTB TRANSISTOR

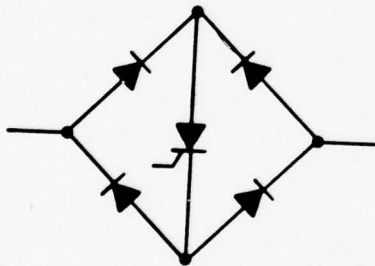

FULL-WAVE SCR

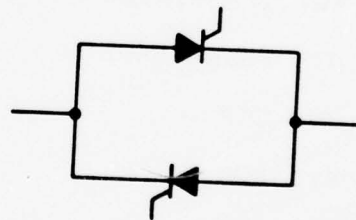

BTB SCR

1764

Figure 2. Pass Section Configuration

Table 2

Pass Section Configuration, Trade Study

	<u>FULL-WAVE TRANSISTOR</u>	<u>FULL-WAVE SCR</u>	<u>BTB TRANSISTOR</u>	<u>BTB SCR</u>
Number of Active Devices	1	1	2	2
Number of Diodes	4	4	2	0
Voltage Drop at 5 Amps (Note 1)	2.4V	2.9V	1.7V	1.5V
Trip Current Interrup- tion Capability	Yes	No	Yes	No
Convenient Zero-Voltage Turn-On	No	No	Yes	Yes
Convenient Zero-Current Turn-Off	No	Yes	Yes	Yes
Inherent Current Limit- ing Adaptability (requires additional transistors)	Yes	No	Yes	No
Drive Circuit Refer- enced to single point	Yes	Yes	Yes	No

Note 1: Assume $V_{DIODE} = 0.7V$, $V_{TRANSISTOR} = 1.0V$, $V_{SCR} = 1.5V$

The back-to-back configurations, either transistor or SCR, offer several advantages over the full-wave circuits:

- a. Lower forward voltage drops, and therefore lower internal power dissipation.
- b. A convenient means for obtaining zero voltage turn-on and zero current turn-off.

2.8.1 ZERO VOLTAGE TURN ON AND ZERO CURRENT TURN OFF

Zero voltage turn-on (ZVTO) and zero current turn-off (ZCTO) are illustrated in Figure 3. ZVTO and ZCTO, along with full-cycle control, provide a number of desirable features:

- a. ZVTO provides a "soft start" for capacitive and resistive loads, and generates the lowest possible $\frac{di}{dt}$ at turn-on.
- b. ZCTO provides essentially zero $\frac{di}{dt}$ at turn-off. This minimizes EMI, and protects the pass element from absorbing the stored energy in an inductive load ($1/2 LI^2$).
- c. Full-cycle control, which is practical only with ZVTO and ZCTO, provides turn-on only on the positive-going edge and turn-off at the same place. This is important for certain types of transformer loads, which have considerable residual magnetic flux following turn-off. If full-cycle control is not used, the result on the next turn-on can be high inrush currents and possible nuisance trips.

A timing diagram showing the implementation of ZVTO, ZCTO, and full-cycle control is shown in Figure 3. The diagram applies equally to transistors and SCR's, in the back-to-back configuration.

Consider first the SCR circuit. The asynchronous control input signal is received by the SSPC. The P Control signal is generated,

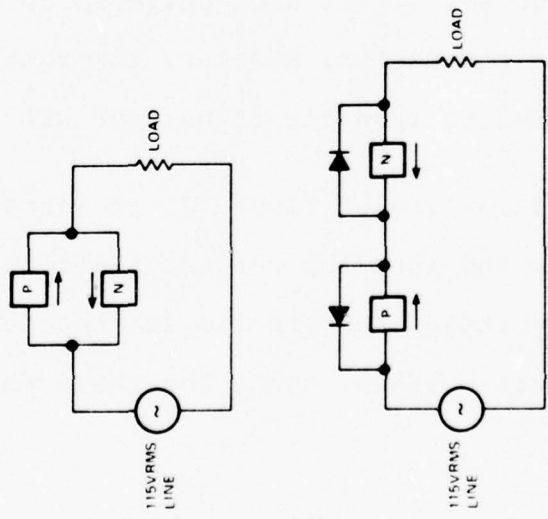
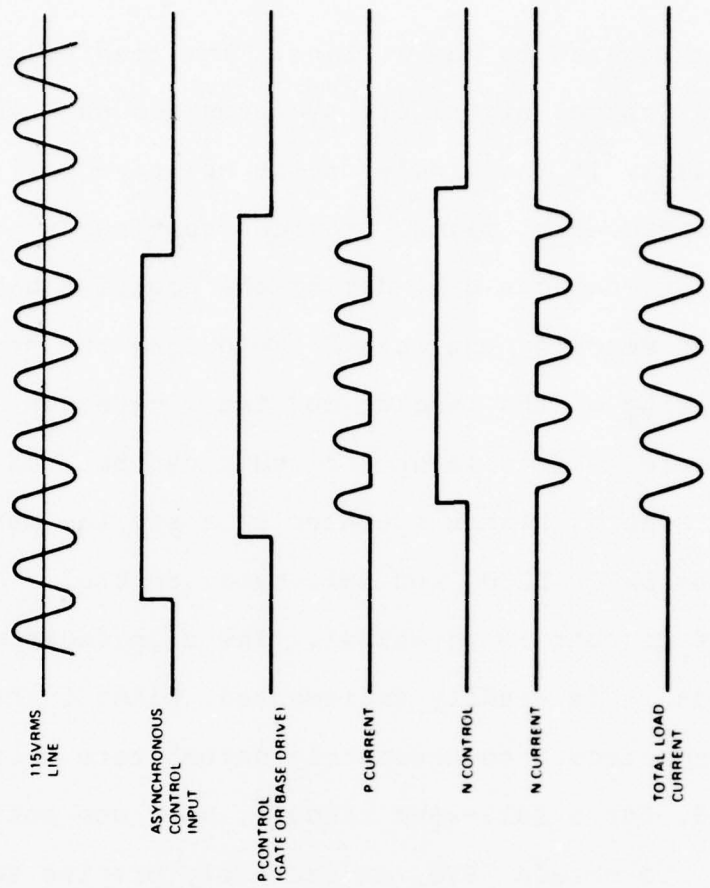

Figure 3. Control On/Off Timing

as shown, synchronized to the AC line. The leading and trailing edges of the P Control signal are synchronized such that they fall approximately in the middle of the negative half-cycle of the line. The P Control signal provides continuous gate drive to the P SCR, which conducts only during the positive half-cycles. By applying and removing the gate drive during the negative half-cycles, the timing of the leading and trailing edges is not critical, and a simple, wide tolerance circuit can be used for the clock. The N Control signal operates in a similar manner, thereby providing clean ZVTO, ZCTO, and full-cycle control. Operation of the transistor circuit is identical. The significance of this circuit is that it is readily implemented, without the need for a critical timing circuit to accurately detect zero crossings. On the other hand, for a full-wave circuit, only one active pass element is used. To obtain ZVTO, an extremely precise zero crossing detector must be built to turn the transistor or SCR on at exactly the positive zero crossing. If the device is an SCR, ZCTO inherently occurs; for a transistor, however, the same zero crossing detector must be used to turn the transistor off.

In the foregoing discussion of Figure 3, it was assumed that the load was resistive, and that the current waveform was therefore in phase with the voltage. No problem is encountered with either capacitive or inductive loads, since the phase shift is always less than 90° .

Thus, the back-to-back configurations, either transistors or SCR's, offer the advantages of lower power, and convenient ZVTO, ZCTO,

and full cycle control. BTB is therefore selected as the pass element configuration.

Another significant consideration concerns the amplitude and time duration of the load current which is allowed to flow during a fault, particularly into a shorted load.

There are three basic options:

- a. SCR - If the SCR is selected as the pass element, and a shorted load occurs early in the half-cycle, the fault current can readily exceed several hundred amperes. This fault current is limited only by the capability of the generator to deliver current, and the various small series impedances, such as:

- (1) Generator source impedance
- (2) Wire impedance
- (3) Connector contact resistance
- (4) Fail-safe fuse resistance
- (5) SSPC current sensor impedance
- (6) Small resistor intentionally used in SSPC to limit fault current.

It should be noted that steady-state power dissipation and other considerations dictate that great effort is generally devoted to minimizing these impedances, and therefore that depending on them to limit fault current must be examined with great care.

For a 5 amp unit, assume that under normal load conditions the drop across this series impedance should not exceed 1 volt. In this case,

$$z_S = \frac{1 \text{ volt}}{5 \text{ amps}} = 0.2 \text{ ohm}$$

Under fault conditions, therefore,

$$I_{\text{fault}} = \frac{115 \text{ volts}}{0.2 \text{ ohm}} = 575 \text{ amps}$$

The energy in this half-cycle pulse is on the order of (115 volts) (575 amps) (1.25 millisecond) = 82.7 joules assuming squarewaves instead of sinewaves. This is a considerable amount of energy, and a considerable amount of current to force through the generator, the SSPC, and the various impedances listed above.

The impact of this surge on the generator must be determined. Each of the series resistances must be carefully studied to measure its ability to absorb substantial energy pulses. For example, several connector pins may be located in the series path, e.g., on the SSPC card connector, the external load center chassis connector, and the load connector, if used. Potential problems can occur due to contamination, temperature/humidity conditions resulting in ice formation, or other adverse conditions which result in

hotspots on the connector pin during high energy surge pulses, and possible damage due to heating.

A tradeoff can be made of steady-state power dissipation, due to I^2R losses, versus fault current limiting:

Z_S	$P_{LOSS} = I^2 Z_S$	I_{FAULT}
0.2 ohm	5.0 watts	575 amps
0.5 ohm	12.5 watts	230 amps
1.0 ohm	25.0 watts	115 amps

Thus, for the SCR, this tradeoff must be made. The most likely result would appear to be on the order of the values listed above; that is, a steady-state power loss of approximately 10 to 25 watts must be tolerated in order to limit fault current to several hundred amps. With whatever limiting is employed, each series impedance must be evaluated for its ability to withstand these high energy surges.

- b. TRANSISTOR (1000% TRIP) - When the transistor is used as the pass element, two techniques are available for limiting the current and energy delivered during a fault. The first of these techniques is 1000% Trip. Basically, the load current is continuously monitored. If the current remains less than 100% (of 5 amps), the SSPC remains ON indefinitely. If the current is between 100% and 1000%, the transistors remain saturated (or very nearly saturated), and the time trip

curve is followed. If the overload remains long enough for time trip to occur, the SSPC trips out, turning off at a zero current crossing (ZCTO). However, if the peak current exceeds 1000%, or approximately 70 amperes, the SSPC trips in a few microseconds, without waiting for the end of the half-cycle. This serves the function of protecting the transistor, as well as limiting the current through the load. Transistors, in general, exhibit secondary breakdown limitations, whereby the transistor cannot remain in an extremely high dissipation region for more than a very short time. For power transistors, this current-voltage-time relationship is always expressed in the Safe Operating Area (SOA) curve specified by the manufacturer. In general, for times on the order of microseconds, the limitation can be considered as an energy specification; that is, the transistor cannot absorb more than a specified number of joules. For the transistors under consideration, this energy ranges from approximately 0.4 joules to 6 joules. When the SSPC encounters a shorted load, it is therefore necessary to turn off the transistor before exceeding this energy requirement. The worst case is when the short occurs at the peak of the cycle. The energy is then approximately

$$\text{Energy} = (V_{\text{peak}}) \times (I_{\text{peak}}) \times (\text{time})$$

For a typical case, assume $t = 10$ microseconds,
Then energy = (160V) (70 amps) (10 microseconds) =
0.112 joules.

This is safely less than the maximum allowable energy rating of the transistor.

A further potential problem resulting from turning the transistor off in mid-cycle is the sustaining voltage rating of the transistor, which is considerably less than the breakdown voltage. The sustaining voltage is particularly important if the load includes inductance. In this case, as the transistor turns off, the collector voltage quickly rises to a value at which the transistor goes into a "sustaining" condition, and clamps the voltage to, for example, 300 volts. The 70 amps of collector current which had been flowing prior to turn-off continues to flow, so that the transistor is now in a very high dissipation state. The transistor must be specified to withstand this stress or not allowed to go into the VCE sustaining region.

Transistors with suitable characteristics for this application are available from several manufacturers, including:

- (1) Motorola
- (2) Power Tech

- (3) Delco
- (4) RCA
- (5) Westinghouse
- (6) International Rectifier

c. TRANSISTOR (CURRENT LIMITING) - Using the transistor as the pass element, a second technique is available for limiting the current and energy delivered during a fault. This involves current limiting at, for example, 300% of rated current. For currents less than 100%, and between 100% and 300%, operation is identical to that of the 1000% Trip technique. That is, the transistors remain saturated until either the control ON signal is removed or the time trip point is reached, at which time the transistors turn off at the next zero current crossing (ZCTO). For heavier loads, or for loads with high inrush currents, such as lamps or motors, the current is limited to 300% by reducing the output voltage. The SSPC remains in this state for a time specified by the time-trip curve, which is on the order of one second. With regard to the circuit design, this current limiting can be accomplished in two ways: the first is by allowing the pass transistors to operate in the linear region, much like a series pass transistor in a power supply voltage regulator. The problem with this is that the power dissipation in the transistor becomes

excessive, particularly if the output is shorted. For a 5 amp unit, a current of 15 amps at 115 volts requires an internal dissipation of approximately 1700 watts, which is well beyond the capability of transistors available today. The time limitation of one second is of no help, since the thermal time constants of transistors are much less than one second, and the steady-state dissipation values must be used. The second way is to dissipate the power (1700 watts) in a resistor. The design of small SSPC's would be limited because of size and thermal requirements of such a resistor.

2.9 PASS ELEMENT DRIVER

2.9.1 TRANSISTOR

The transistor, in the BTB configuration, has the advantage that both emitters are connected to ground ("ground", in this sense, refers to the common of the control circuit), thereby permitting symmetrical base drive circuits, in a simple configuration. However, this does not imply that the entire drive circuit is simpler than the SCR drive circuit, because the level of base current required is substantially higher than the SCR gate current.

A basic limitation of power transistors in general is that h_{FE} falls off rapidly as a function of I_C . Since $I_B = I_C/h_{FE}$, large values of I_B are required for very large values of I_C , which occurs during overload conditions. A typical h_{FE} characteristic

curve is illustrated in Figure 4. A method often used to alleviate this problem is to use parallel transistors to achieve a higher net h_{FE} . This is also shown in Figure 4. For example, if three transistors are used in parallel, the net h_{FE} of the complete triplet is the high value shown on the curve. Analysis and test data have shown that parallel transistors, when operated at very high collector currents and exhibiting this h_{FE} fall-off, will share collector current very nearly equally, even without separate emitter resistors. Basically, this is because of the inherent feedback mechanism; as one transistor tries to take more than its share of the total current, its h_{FE} drops, and it therefore takes less current. Equilibrium is established, with each transistor conducting its proper share.

Another factor affecting h_{FE} is V_{CE} . For a given I_C , h_{FE} increases rapidly with increasing V_{CE} . That is, as the transistor comes out of saturation, its h_{FE} increases. This tends to be a helpful factor, since, during overload conditions, approaching 1000% overload, the transistor comes out of saturation, thereby increasing the h_{FE} and reducing the I_B requirement.

In designing the pass element predriver, the primary problem is to generate and control the base current as efficiently as possible. Base current is no particular problem for normal loads or small (<300%) overloads, but requires careful consideration for overloads approaching 1000%. The circuit objective is to derive the base current from the line directly, rather than through the internal power supply, in order to reduce both power consumption and the size of the power supply transformer.

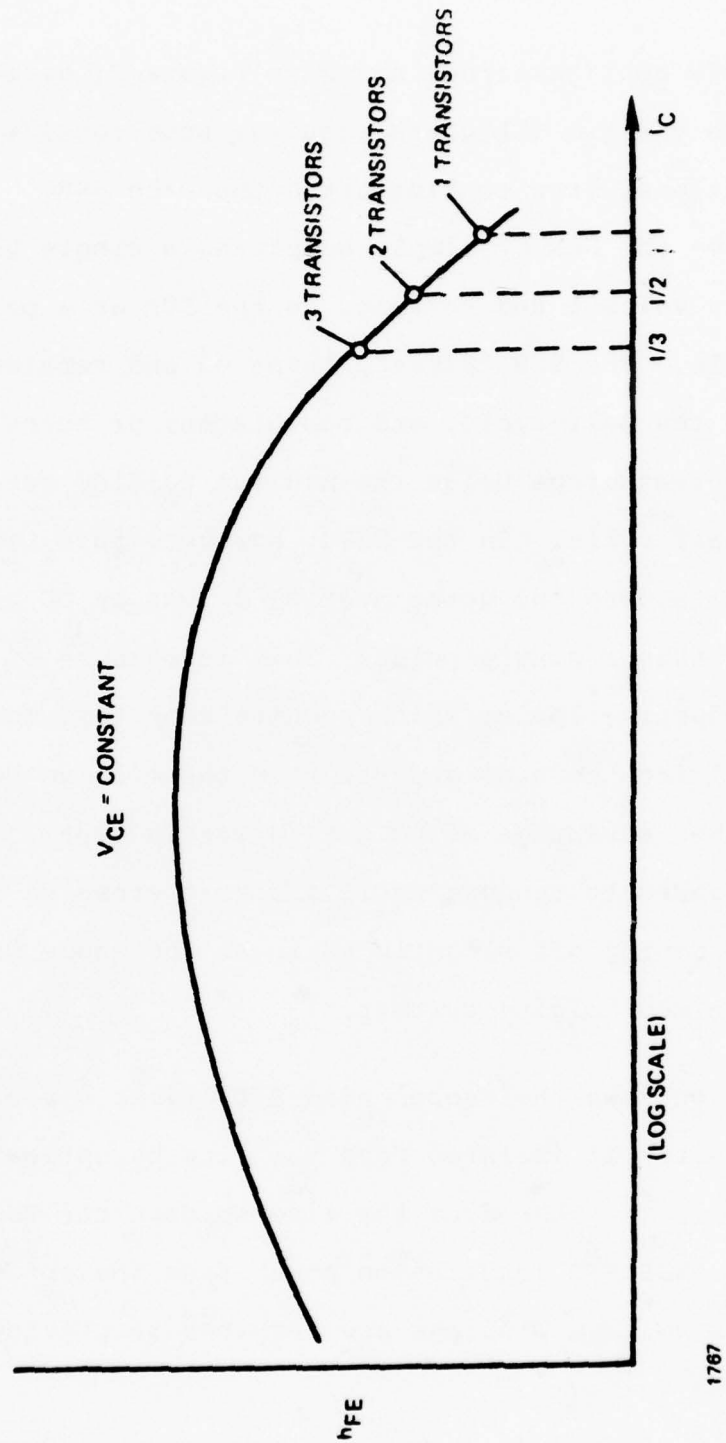

1767

Figure 4. Typical HFE Characteristic Curve

2.9.2 SCR

In the BTB SCR configuration, shown in Figure 2, design of the circuit to drive the two SCR gates requires some consideration. For many applications, less sophisticated than the SSPC, it is sufficient to drive the SCR by simply supplying a single gate pulse, with adequate voltage and current, to the SCR at a point early in the half-cycle. The SCR "fires", turns on and remains on for the remainder of the half-cycle, and commutates, or turns off, when the anode current drops below the minimum holding current at the end of the half-cycle. In the SSPC, however, this simple approach is not adequate, and the gates must be driven by DC or a pulse train rather than a single pulse. This is because of the possibility of inductive loads, which require some time for the current to "build up" from zero to greater than the minimum holding current. A further advantage of DC gate drive is that, on turn-off, the SCR continues to conduct until the zero crossing of the current, rather than turning off slightly early as the anode current drops below the minimum holding current.

In Figure 5, showing the recommended SCR driver circuit, the LSI control circuitry is isolated from the line by optical-couplers. The drive power is taken from the line through the VMOS FET transistor. The VMOS FET requires no power from the optical coupler. Separate Bias Voltage Windings are required to provide the proper gate to source voltage.

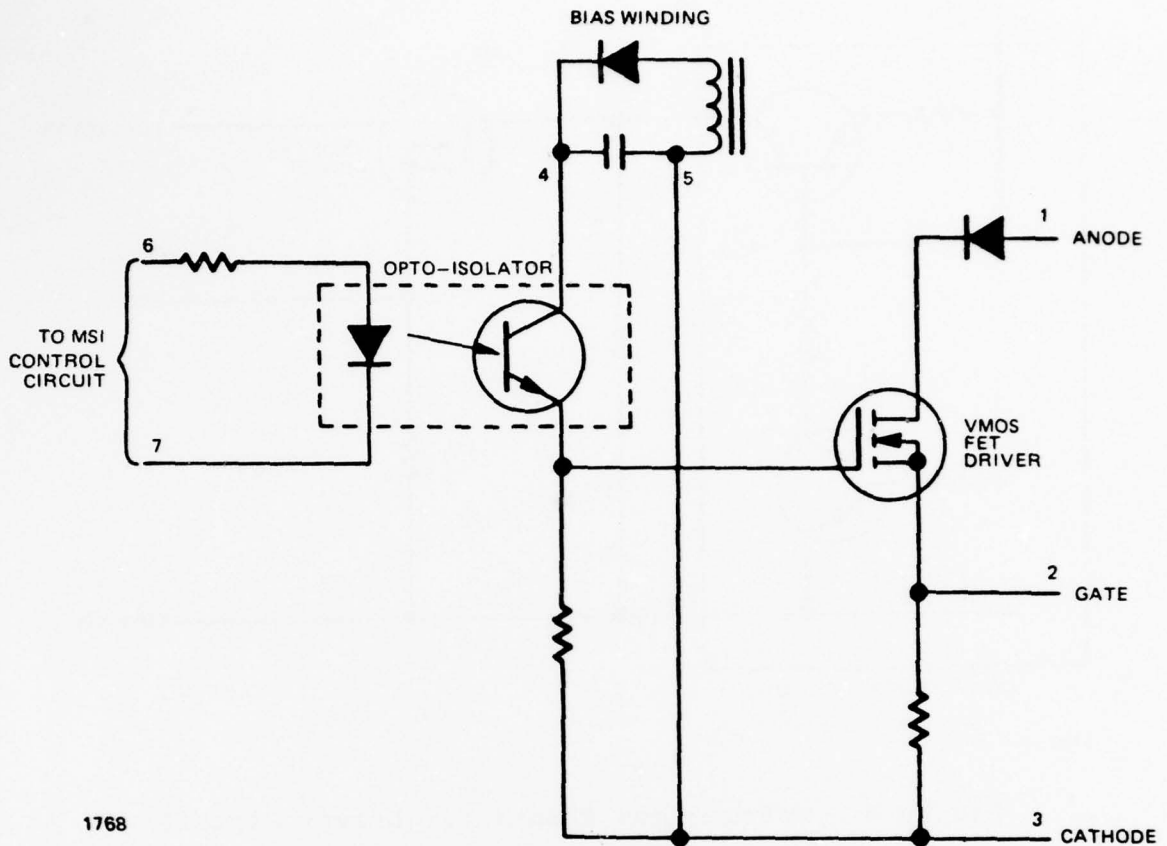

1768

Figure 5. Recommended SCR Driver Circuit

2.9.3 RECOMMENDED DRIVE CIRCUIT

The recommended drive circuit in Figure 6 uses a VMOS FET transistor, in a modified Darlington configuration.

A FET predriver has several very attractive features. The control of the FET is by voltage rather than current. At zero volts VGS, the FET is off. At +10VDC, the FET turns on and exhibits an RDS (ON) of less than 2 ohms. The two great advantages of the FET are its virtually infinite input impedance, and lack of a saturation voltage. Siliconix will soon have available devices, which have a breakdown voltage rating (BVDSS) of 400 volts and 5 amp drain current (ID) rating.

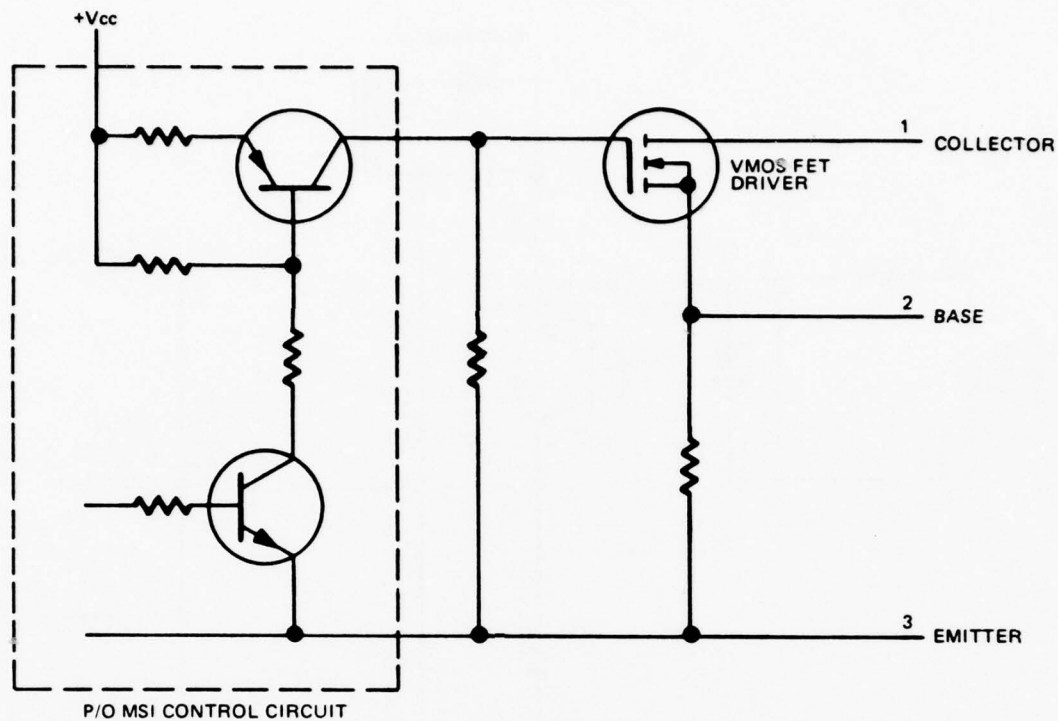

1769

Figure 6. Recommended Transistor Driver Circuit

2.10 FUSE AND LOAD COMPATIBILITY

The fail-safe fuse is required in order to protect the wire in case of an SSPC failure. This failure can be either a shorted load and a shorted SSPC pass section, or an internal SSPC short from the bus to ground, e.g. from a shorted internal power supply transformer.

The fuse must go on the input side of the SSPC, to protect against shorts internal to the SSPC. The fuse may be located on the SSPC card, or in the Load Center chassis. In the can version, the fuse must be mounted inside the can, since it may operate by itself.

The Load Center fusing diagrams are shown in Figure 7. The upper diagram depicts the fuses located on the SSPC card. This allows

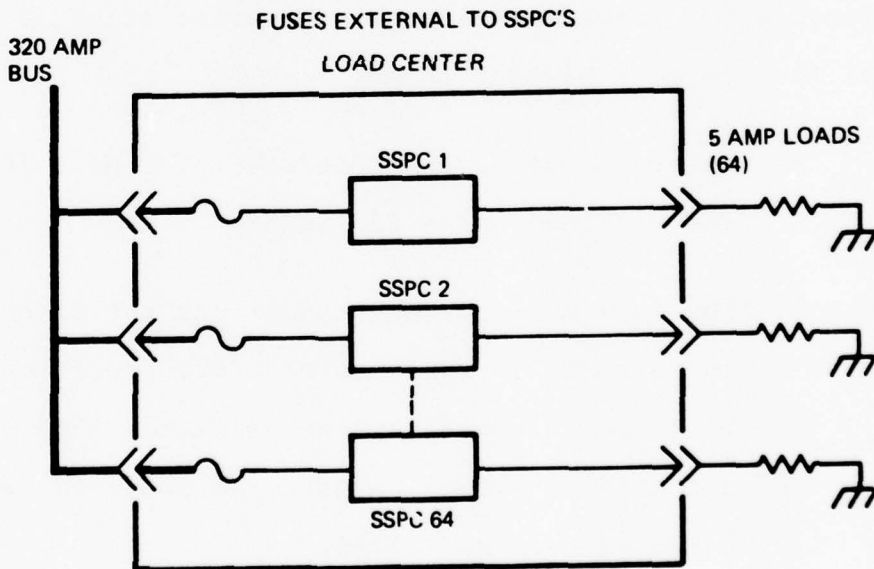
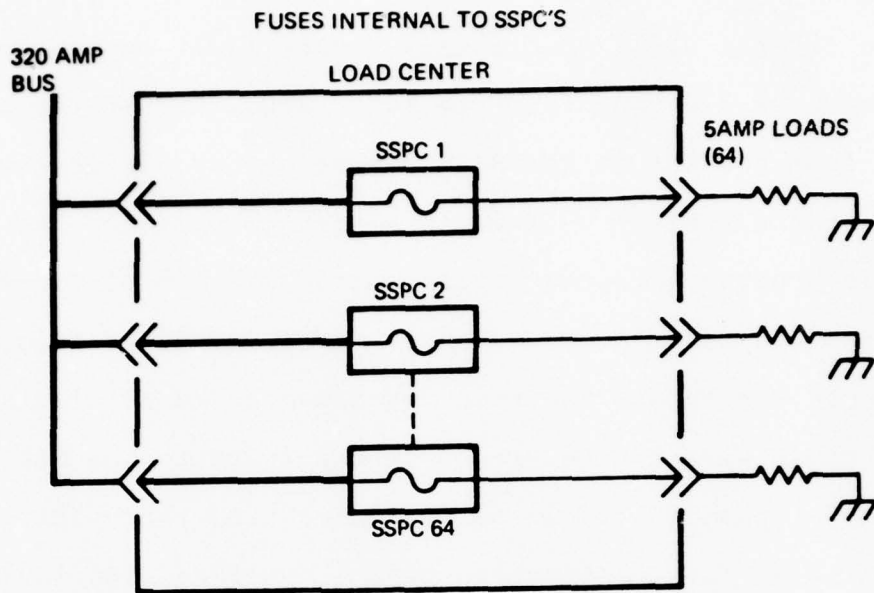

1763

Figure 7. Load Center Locations

a possible problem condition: a short to ground might conceivably occur, at the SSPC card connector, due to a bent pin, foreign metallic object, etc. Should this occur, fault current will flow in excess of 320 amps from the bus. Thus, either the Load Center wires from the bus to the SSPC's must be capable of conducting 320 amps, or these wires will be in danger of damage. The solution to this problem is shown in the bottom diagram of Figure 7. By locating the fuses on the chassis, as close as practical to the bus input connector, the risk described above is eliminated, and small gauge wire can be used from the fuses to the SSPC's. An additional possibility is to use indicating fuseholders, thereby providing a visual indication of a blown fuse, and facilitating maintenance procedures.

In selecting the value and trip-out characteristics of the fuse, several factors must be considered:

- a. The fuse must open and protect the wire in case of a shorted load and a failed SSPC.
- b. The fuse must not open under any set of conditions for a normally functioning SSPC. Specifically, this includes inrushes from normal loads such as lamps and motors, as well as shorted loads for which the SSPC trips as specified.

To some extent, these are mutually conflicting requirements, and selection of a fuse to simultaneously satisfy both may be difficult if an SCR is used as the pass element, since an extremely

high current, possibly several hundred amps, can flow for a full half-cycle. With the transistor, on the other hand, the fault energy is limited to a much smaller value, and the fuse is correspondingly easier to select.

As stated, the fuse must "open and protect the wire". This implies a fault interruption capability, i.e. the fuse must not sustain an arc after "opening" even though a thousand or more amperes at the line voltage may be available from the power source. This generally sets the minimum length of the fuse, and can result in a somewhat large size which is difficult to package.

Several standard fuses were investigated for use in the SSPC for the required characteristics. Microfuses, (LITTELFUSE type 278) were tested for surge handling. This type of fuse, attractive because of its small size, would predictably arc and might burn associated circuitry. It would arc at approximately 150 amps and continue to arc as long as 7 to 8 milliseconds. Larger fuses (LITTELFUSE Type 8AG), because of their size, allowed the arcing to completely extinguish in 1 to 2 ms. Suitable fuses from the viewpoint of time-current characteristics for a transistor pass section are the following:

MDV-7	(BUSSMAN)
MDX-7	(BUSSMAN)
315008	(LITTELFUSE)

Study is being pursued by Telephonics on the subject of "fatigue" failure of fuses when subjected to many operations with surge

currents. The Gould Shawnut type AGY15 fuse is under consideration for SSPC units where fatigue is a problem. This type of fuse is called a Silver Sand fuse.

2.11 CONTROL INPUT/OUTPUT

The interface between the EMUX terminal and the SSPC may take any of several forms. The only signal which is definitely required is the Control ON/OFF signal, which turns the SSPC on and off. At least three possible signals have been considered to provide useful information from the SSPC to the EMUX:

- a. TRIP - indicates that the SSPC has tripped, due to an overload. The trip is reset by removing the Control ON/OFF signal.
- b. STATUS - indicates that the SSPC output is high, independent of the Control ON/OFF input. The output may be high due to normal operation, or a shorted pass element, or voltage coming to the output from another source. Note that "high" may be defined as the presence of either voltage or current.
- c. FAULT - the exclusive - OR function of ON and STATUS:

ON	STATUS	FAULT
0	0	0
0	1	1
1	0	1
1	1	0

That is, FAULT indicates that the output does not agree with the input. This can be due to either a failed SSPC, or voltage coming to an SSPC in the OFF state from another source, such as another SSPC connected in parallel.

Various combinations of these signals have been considered and used for various applications. Generally, TRIP is used, possibly with either STATUS or FAULT. STATUS and FAULT are basically redundant, since the EMUX terminal always knows the state of the ON signal. STATUS and FAULT are therefore not used in the same SSPC system.

The technique of transmission of these signals from the SSPC to the EMUX terminal offers several possibilities. For example, to send TRIP and STATUS along with ON, three transmission techniques are apparent.

- a. 6 wires - one isolated pair of wires for each signal.
- b. 4 wires - one signal wire for each signal, with a common ground.
- c. 2 wires - all three signals are transferred over a single pair of wires. The ON signal is supplied as a constant current source between 3 and 10 milliamperes. TRIP and STATUS are represented by different preselected input impedances, looking into the SSPC control terminals. The EMUX therefore measures the voltage

across the control input, performs a simple input to level conversion, and knows the TRIP and STATUS. Thus, in a manner similar to multiplexing, several discrete bits of information are conveyed over a single pair of wires. TRIP and STATUS may also be learned by transmitting a fast pulse, such as on the order of 10 microseconds, which is faster than the SSPC response time, and therefore is not recognized as a valid ON command.

All of these techniques are completely feasible, and present no serious technical problems in the SSPC design. The tradeoffs are clearly defined. The two-wire system saves connector pins and wiring, at the cost of a small amount of additional circuitry in both the SSPC and the EMUX terminal. The final decision must certainly consider the following factors:

- a. Design of the SSPC
- b. Design of the EMUX terminal
- c. Wiring between the SSPC and the EMUX terminal

For a can version, located relatively distant from the EMUX terminal, the 2 wire approach seems advantageous, due to the saving of wires. A 2 wire interface I/O monochip design has been completed and is the recommended I/O for a new SSPC. The trade studies by both Vought Company and Douglas Aircraft Company support the 2 wire interface approach.

For a Load Center, which is a chassis containing one EMUX terminal and perhaps 64 SSPC's, the advantage of the 2 wire approach is less clear, and depends to a great extent on the detailed design of the EMUX terminal I/O ports. By using three separate signal wires, with a single common ground for all SSPC's, the wiring may be very reasonable, particularly if a multilayer mother board or backplane, or similar approach, is used.

The critical components of the I/O interface circuitry are the Monochip device and the optical couplers.

The selection of the optical couplers is determined by several factors such as whether the SSPC is to be in a can (hybridized) or on a printed circuit card.

If nuclear radiation hardening is desired then PIN diodes must be used with an LED assembled in a customized hybrid package. The orientation of the PIN diode and LED must be selected to provide maximum optical coupling consistent with voltage isolation requirements. This custom-made optical coupler may be used on a printed circuit card if the coupler is first hermetically sealed. Otherwise, it must be placed inside a canned SSPC which is hermetically sealed.

Acceptable hermetically sealed optical couplers or discrete chips suitable for use with a SSPC printed circuit board or custom hybrid include the following:

<u>MANUFACTURER</u>	<u>P/N</u>	<u>NUCLEAR RADIATION HARDENING</u>	<u>ISOLATION</u>	<u>PACKAGE</u>
Hewlett- Packard	HCPL-2770 5082-4200	Yes Yes	*1500 VDC -	16 PIN DIP PIN diode chip
Monsanto	MCT 4	No	1000 VDC	T0-18
Texas Instruments	TIL120, 121 TIL107, 108	No No	1000 VDC 1000 VDC	TO-72 Cylindrical
Optron	JAN TX 4N22, 34	No	1000 VDC	TO-5
Motorola	MRD 500, 510 MRD 601, 2, 3, 4	Yes Yes	- -	PIN diode chip Photo detector chip
Xciton	CXC 1818 1R	Yes	-	Photo detector chip

*Quad OPTO Coupler - Isolation is between input to output - not between outputs.

2.12 INTERNAL POWER SUPPLY

The final internal power supply design must be finalized after all other power controller circuitry is completed. Also, the maximum allowable volume available and whether the SSPC is on a printed circuit card or in a can will impact the design approach. The design of a typical 10 volt unregulated power supply per MIL-STD-704B for an AC SSPC will be considered.

Requirements:

- 10 VDC at nominal line
- 6.6 VDC minimum at dropout
- 100 MADC maximum load current

Assumptions:

Rectification efficiency = 0.9

The line voltage (primary) V_p will vary as follows:

$V_p = 80$ volts to 180 volts (transient)

= 100 volts to 125 volts (steady-state under voltage and over voltage)

SYMBOLS AND ABBREVIATIONS

V_P	Transformer Primary Voltage
N	Transformer Turns Ratio
V_S	Transformer Secondary Voltage
VDC	Average DC Output Voltage
C_F	Output Capacitor
η	Rectification Efficiency
SS	Steady State
OV	Overvoltage
UV	Undervoltage

Calculate transformer turns ratio N:

$$V_{DC} = \eta V_S; V_S = \frac{V_{DC}}{\eta} = \frac{10V}{.9} = 11.1 \text{ VpK}$$

$$V_{S(RMS)} = \frac{11.1}{\sqrt{2}} = 7.9V$$

$$N = \frac{V_P}{V_S} = \frac{100}{7.9} = 12.7 \Rightarrow 13:1$$

$$V_{DC}^{MAX SS} = \frac{V_P \sqrt{2}}{N} = 12.2 \text{ VDC}$$

$$V_{DC}^{MAX OV} = \frac{(.9) (180) (\sqrt{2})}{13} = 17.6 \text{ V}$$

$$V_{DC}^{MIN UV} = \frac{(.9) (80) (\sqrt{2})}{13} = 7.8 \text{ V}$$

$$7.8 \text{ V} > (6.6 \text{ V @ circuit dropout})$$

To prevent the power controller from changing states or the pass elements from operating in the linear region, due to the wide variation in the input line voltages, a pre-regulator or a capacitor energy storage system must be considered.

1. The following is the capacitor storage approach for absorbing line transients of 180 volts rms (for 100 ms) and 55 volts rms (for 50 ms) a goal set by Telephonics but not required by MIL-STD-704B. Refer to Figure 8 for diagram.

$$V_{DC} \text{ at } V_{IN} = 55 \text{ V rms} = \frac{\eta V_P \sqrt{2}}{N}$$

$$= \frac{(.9) (55) (\sqrt{2})}{13} = 5.4 \text{ V} < (6.6 \text{ V is circuit dropout voltage})$$

2. Calculate value of C required to maintain voltage above 6.6V (circuit dropout).

$$C = \frac{IXT}{\Delta V} = \frac{100 \text{ MA} \times 50 \text{ MS}}{(10 - 6.6 \text{ V})} = 1470 \text{ MFD}$$

A 1500 MFD/25W VDC aluminum capacitor is 3/4" diameter by 2-5/8" long with a temperature range of -55°C to +85°C.

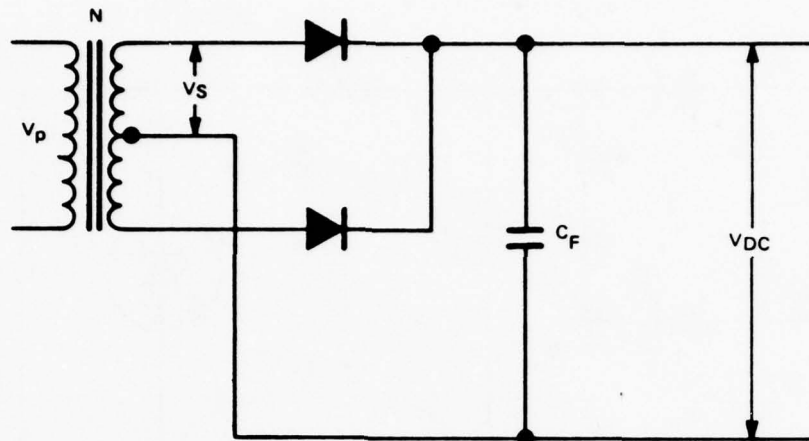

1770

Figure 8. Internal Power Supply Schematic

The critical circuits in the SSPC such as the analog timing circuits and the reference voltages for the current sensor comparator cannot operate properly with a 3:1 variation in supply voltage. Some means of regulating critical voltages must be provided. There are 3 approaches that will be considered, (1) using a zener diode shunt regulator, (2) using a series transistor regulator, and (3) a switching regulator.

The zener diode shunt regulator is the simplest approach. Referring to Figure 9, the minimum and maximum values of VDC for $V_{Line} = 100 \text{ VAC}$ to 125 VAC , as load current varies from 30 MA to 50 mA , are calculated in the following paragraphs.

The voltage across the filter capacitor:

$$V_{CF \text{ MIN}} = 10V$$

$$V_{CF \text{ MAX}} = 12.2V$$

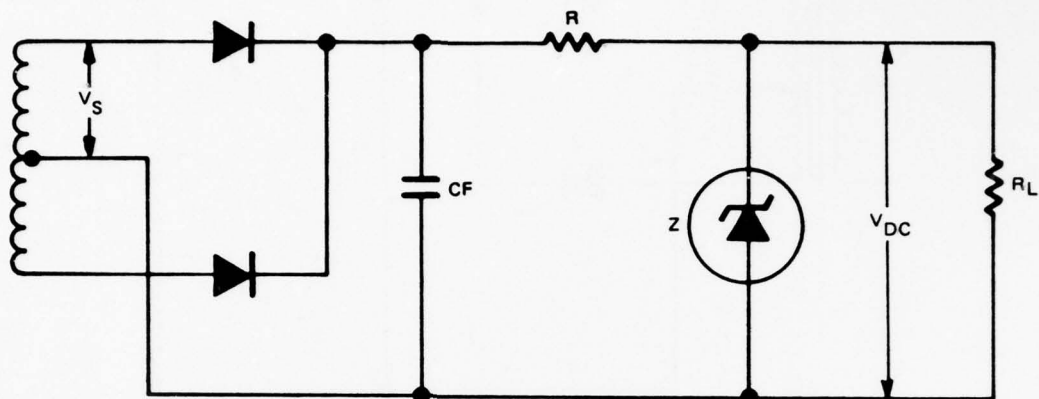

1771

Figure 9. Zener Regulated Power Supply

Since the dropout voltage is 6.6 VDC in this example, a 7.5 volt zener is selected, and with typical load and zener currents:

$$R = \frac{V_{CF(MIN)} - V_Z(MAX)}{I_Z(MIN) + I_L(MAX)} = \frac{10V - 7.5V}{34 + 90 \text{ MA}} = 20.2 \text{ ohms}$$

$$I_{R(MAX)} = \frac{V_{CF(MAX)} - V_Z(MIN)}{R_{MIN}} = \frac{12.2 - 7.5}{20.2} = 233 \text{ MA Steady State}$$

$$I_Z(MAX) = I_{R(MAX)} - I_{RL(MIN)} = 233 - 30 = 203 \text{ MA}$$

$$P_{d(MAX)}(ZENER) = V_Z \times I_Z(MAX) = 7.5V \times 203 \text{ MA} = 1.52 \text{ Watts}$$

$$P_{MAX(RES)} = I^2 R = (.233A)^2 (20.2) = 1.10 \text{ Watts}$$

$$\begin{aligned} \text{MAX Steady State Power} &= V_{CF(MAX)} \times I_{R(MAX)} = 12.2V \times .233A \\ &= 2.84 \text{ Watts} + \text{Rectifiers and transformer losses} \end{aligned}$$

$$\text{MAX Output Power} = 7.5\text{V} \times .090\text{A} = .675\text{W}$$

$$\text{Power Supply Efficiency} \leq \frac{.67\text{W}}{2.84} = 23\% \text{ at full load current}$$

The Standby Power dissipation is the following:

$$P_{\text{dissipation}} = [V_{\text{CF(MAX)}} \times I_{\text{Z(MAX)}}] = 12.2\text{V} \times 233 \text{ mA} = 2.84 \text{ Watts} + \text{Rectifiers and transformer losses which is the same as the steady-state power.}$$

For the series dissipation regulator approach, refer to Figure 10.

Choosing the filter capacitor C_F , the ripple approximation is:

$$\frac{1}{2} V_{\text{RIP(P-P)}} = \frac{I \times T}{C_F} = \frac{.09\text{A} \times 1.25 \times 10^{-3} \text{ sec}}{100 \times 10^{-6} \text{ fd}} = 1.125\text{V}$$

Where $C = 100 \text{ MFD}$

$$T = 1.25 \text{ MS @ } 400 \text{ Hz}$$

$$V_{\text{CF(MIN)}} = V_O + \frac{1}{2} V_{\text{RIP(P-P)}} + V_{\text{SAT}}$$

$$V_{\text{CF(MAX)}} = 12.2\text{V}$$

$$P_{\text{(DISSIPATION)}} = [V_{\text{CF(MAX)}} - V_{\text{O(MIN)}}] I_{\text{L(MAX)}} = (12.2 - 7.5) (.09\text{A}) \\ = 0.423 \text{ watts which is the maximum steady-state power dissipation in the pass transistor excluding rectifiers and the transformer.}$$

The maximum transient power dissipation at 180 VAC input for 100 milliseconds is the following: Assuming a rectification efficiency $\eta = 0.9$.

$P_{(DISSIPATION)} = (17.6 - 7.5) (.09A) = 0.91$ watts for .1 sec which is only 91 millijoules, well within the energy capability of most medium power transistors. The standby power dissipation is the following:

$V_{CF(MAX)} \times I_{standby} = 12.2V \times .002 MA = 24.4$ milliwatts, assuming a UA723 or similar IC voltage regulator as the error amplifier.

The analysis for a switching regulator is based on the circuit in Figure 11.

The following expression is used to calculate the average power dissipation in the switching regulator.

$$\begin{aligned}
 P_{ave} &= \frac{1}{\tau} \int_0^{T_{on}} V_{CE(SAT)} I_p dt + \int_{T_{on}}^{T_{on} + T_{sw}} \left(I_p - I_p \frac{t}{t_{sw}} \right) \left(V_p \frac{t}{t_{sw}} \right) dt \\
 &+ \int_{T_{on} + T_{sw}}^{\tau - T_{sw}} V_p I_{CO} dt + \int_{\tau - T_{sw}}^{\tau} \left(V_p - V_p \frac{t}{t_{sw}} \right) \left(I_p \frac{t}{t_{sw}} \right) dt \\
 &= \underbrace{\frac{V_{CE(SAT)} I_p T_{on}}{\tau}}_{On} + \underbrace{\frac{V_p I_{co} T_{off}}{\tau}}_{Off} + \underbrace{\frac{I_p V_p T_{sw}}{3\tau}}_{Switching}
 \end{aligned}$$

T_{on} transistor switch on (transistor in saturation)

T_{sw} switch time (transistor in linear mode)

V_p Peak source voltage (V_{CF})

I_p Collector current

τ Period of constant frequency

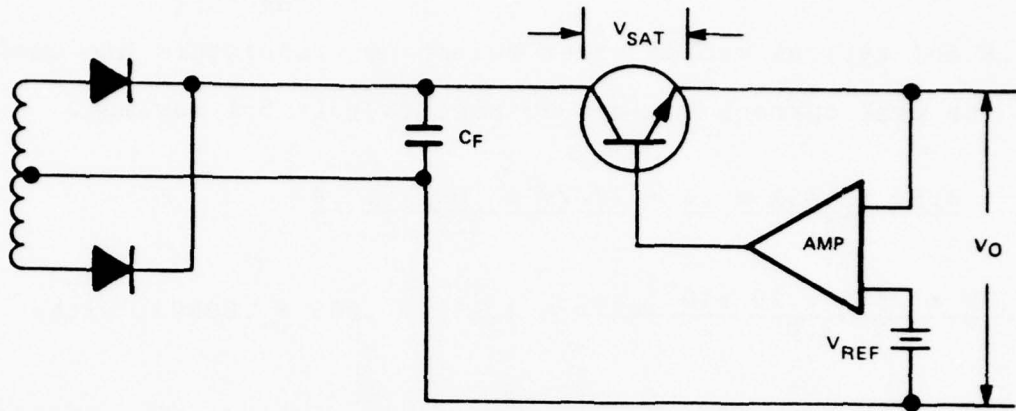

1772

Figure 10. Dissipative Series Regulator

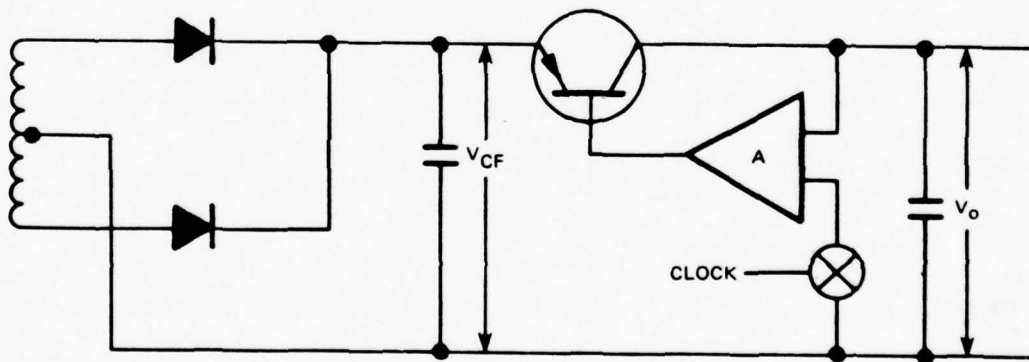

1773

Figure 11. Switching Regulator

At low line where the efficiency is minimum, $\frac{t_{on}}{t_{on}+t_{off}}$ is assumed to be 0.6 and typical medium power switching transistors are used, also the peak current to load current (DC) is 5:1 maximum.

$$P_{ave} = \frac{0.5V \times .45A \times .6}{1.0} + \frac{12.2V \times .001A \times .4}{1.0} + \frac{12.2V \times .45A \times 10 \times 10^{-6} \text{ sec}}{3.0} = (.135 + .005 + .00002) \text{ watts}$$

= 0.136 watts + rectifiers and transformer losses. The efficiency of each approach is tabulated below:

<u>ZENER DIODE</u>	<u>DISSIPATIVE</u>	<u>SWITCHING</u>
23.8%	61.4%	83.2%

The zener approach is obviously not good because of low efficiency and high standby power drain.

The dissipative regulator could be used providing the filter capacitor provides the energy storage required at the 55 VAC input line transient. This also applies to the switching regulator, however a much smaller capacitor could be used.

2.13 STATUS MONITOR

The Status Monitor or Built-in-test (BIT) indicates the presence or absence of either load voltage or load current. The output status circuit for voltage monitoring is shown in Figure 12. The output status circuit consists of a full-wave diode bridge across the SSPC output terminals, driving the LED emitter of an optical coupler. When the output voltage is high, the LED turns on, and status is

indicated. Implementing the status sensing in this way, as opposed to current sensing, requires very few components. The voltage status monitor can be incorporated with the output shunt circuit provided that the input current to the optocoupler does not exceed a few hundred microamperes. If nuclear hardening is necessary and a PIN diode detector is used, the input current required is at least 6 milliamperes. This amount of current when dropped across the SSPC in the off-state, will result in over 0.5 watts dissipation. Whenever two SSPC's are driving the same load, both will indicate ON status when only one SSPC is actually ON, causing improper BIT information. The circuit in Figure 12 combines the status and shunt functions, and allows the shunt optocoupler transistor to operate with a low VCE.

The output status circuit block diagram for load current is shown in Figure 13. This circuit is slightly more complicated and requires a few more components than load voltage monitoring. Also, two channels are required when 2 inverse parallel SCR's are used as the pass section elements because separate current sense resistors must be monitored (see Figure 14) unless a dual rail power supply is used. The load current status circuit must measure a small percentage of the normal load current within a few percent over the full temperature range of -55°C to $+125^{\circ}\text{C}$ requiring a stable reference voltage and error amplifier.

Current monitoring is the more desirable of the two methods of monitoring the load status. If the load is open circuited or the power controller fuse is open, the correct status will be indicated.

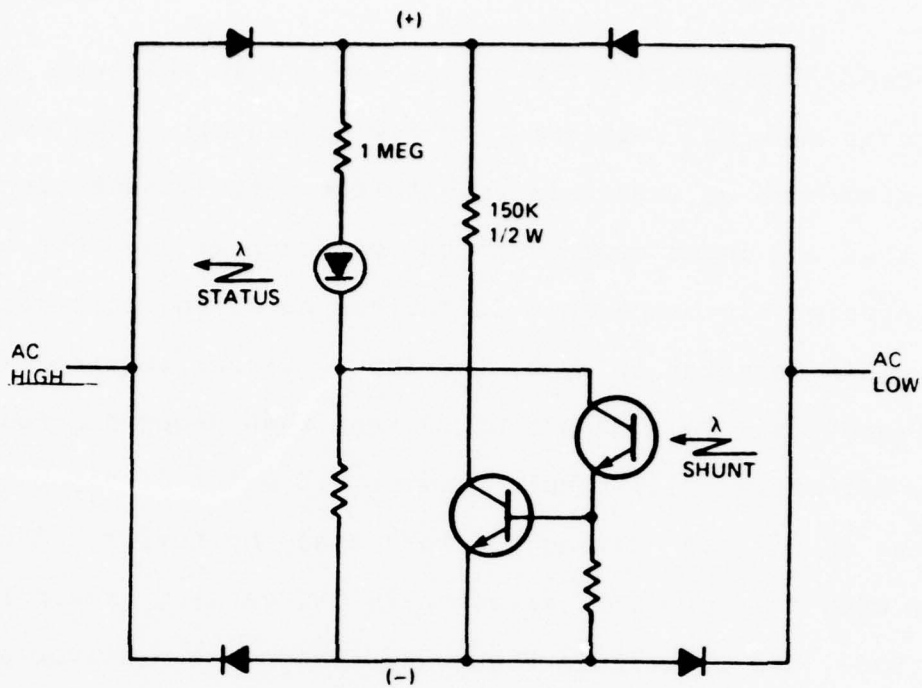

1774
Figure 12. Output Status Circuit for Load Voltage Monitoring

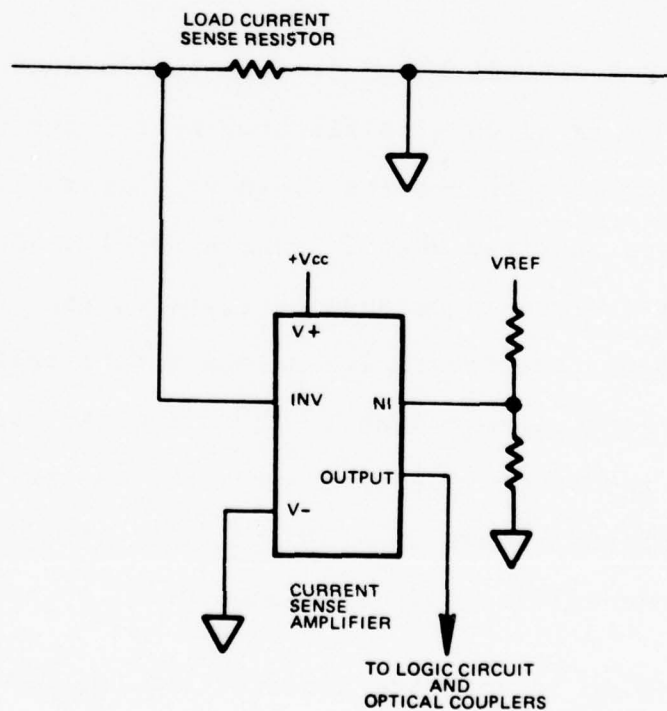

1775
Figure 13. 10% Load Current Status Monitor for Transistor Pass Section

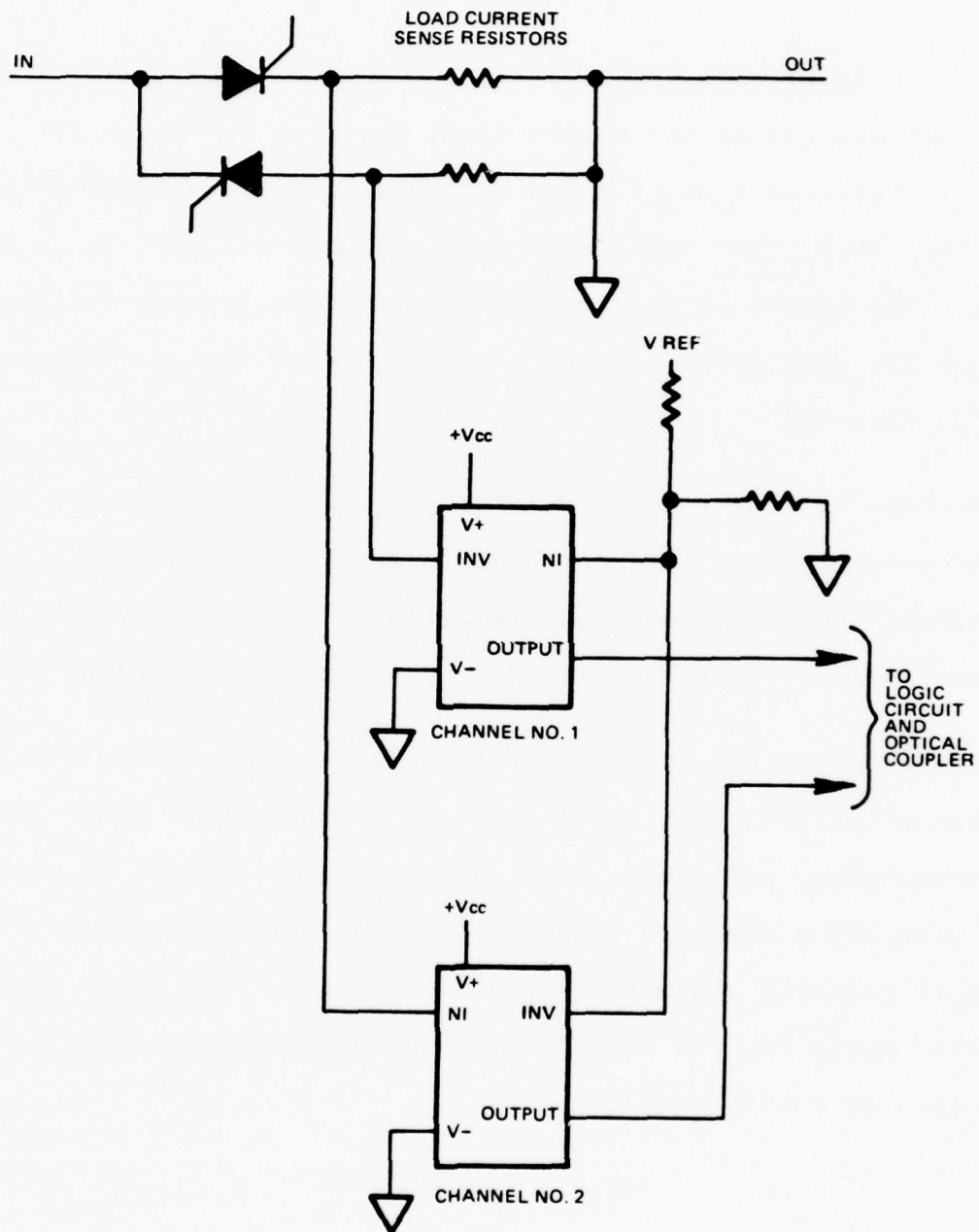

1776

Figure 14. Load Current Status Monitor for SCR Pass Section

Recommended is the following:

STATUS = 0, Load current <10% rated current

STATUS = 1, Load current >15% rated current

2.14 OUTPUT SHUNT (SAFETY)

The block diagram of the output shunt is shown in Figure 15. The shunt is required primarily for personnel safety, as well as to insure that very light loads will turn off when the SSPC is in the OFF state. The source of the problem is off-state leakage currents, (I_L) through the pass elements, and snubber current (I_S) through the snubber network.

The snubber is required for dv/dt suppression, if SCR's are used as the pass elements. If no shunt is used, and the load is open, to examine the worst case, the full 115VAC appears across the output terminals. To personnel, this can represent a serious hazard.

Although the current level may not be high enough to be lethal, the human reflex action resulting from an unexpected shock can cause secondary accidents, e.g. falling from a ladder. To solve this problem, a shunt is added. The shunt could conceivably be a simple resistor connected across the output. The value of the resistor would be such that $I_L + I_S$ would produce a voltage of less than 30 volts. That is,

$$R_{SHUNT} \leq \frac{30 \text{ Volts}}{I_L + I_S}$$

For a typical transistor pass section, no snubber is required, and I_L is less than 0.2 milliamperes. Thus, $R_{SHUNT} = 150K$. When

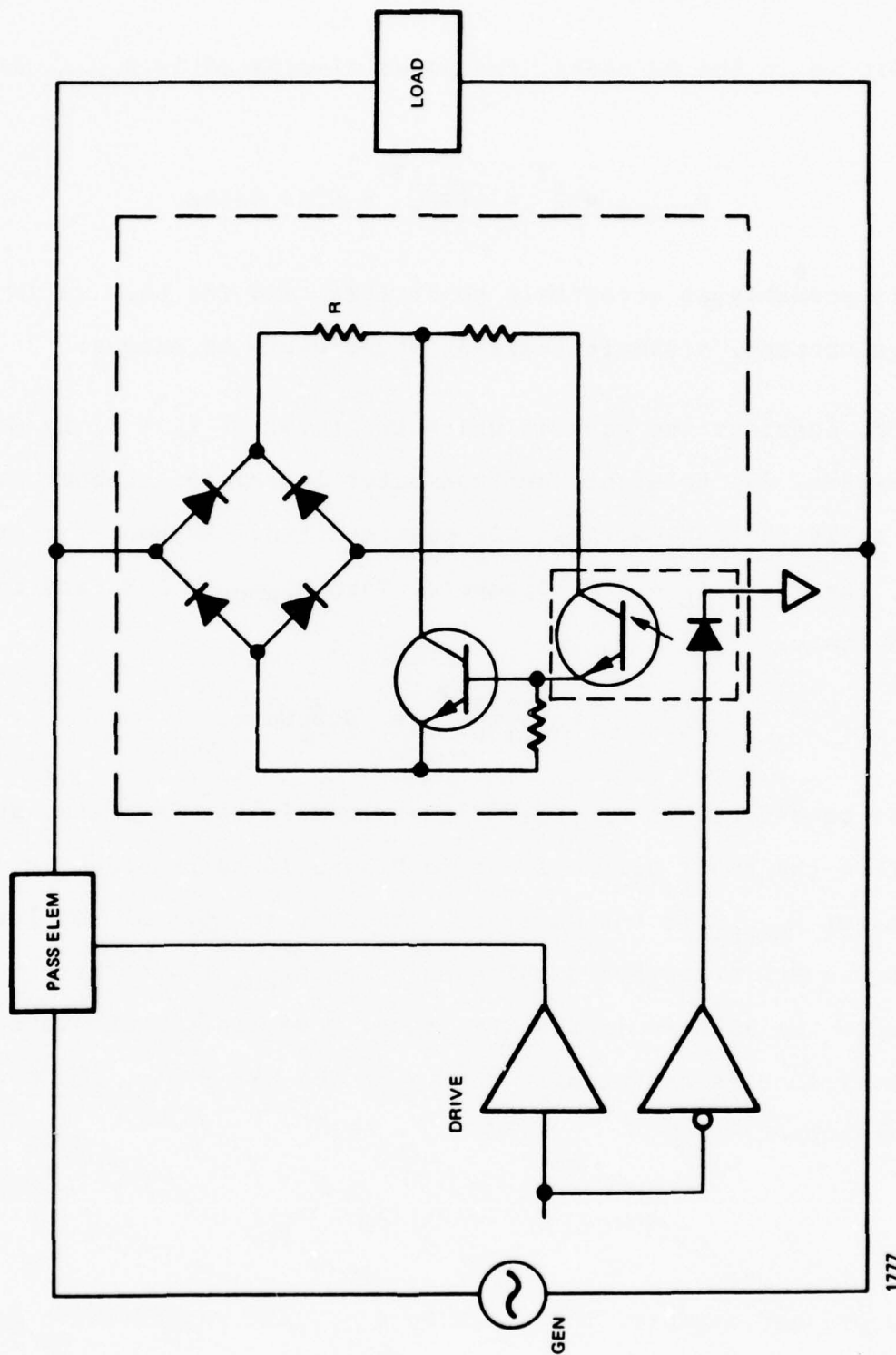

Figure 15. Block Diagram of Output Shunt

the SSPC is in the ON state, the power dissipated in R_{SHUNT} would be,

$$P_{SHUNT} = \frac{E^2}{R} = \frac{(115)^2}{150K} = 0.09 \text{ Watts}$$

This is probably an acceptable power loss, and for this value of leakage current, a simple resistor shunt would be adequate.

However, consider the case in which the total of $I_S + I_L$ is somewhat higher, due to higher semiconductor leakage or snubber current, as is the case with an SCR pass section. Assume, for example, that $I_S + I_L = 2$ milliamperes. Then $R_{SHUNT} = 15K$, and in the ON state,

$$P_{SHUNT} = \frac{(115)^2}{15K} = 0.9 \text{ Watts}$$

This is considered an excessive power loss in the ON state, and therefore the shunt switch shown in Figure 15 is provided to disconnect R_{SHUNT} in the ON state. This is an optical coupler driving an NPN transistor, which switches R_{SHUNT} into the circuit only when the SSPC is in the OFF state. Thus, in the ON state, the power loss is essentially zero. In the OFF state, the power loss is approximately,

$$P_{LOSS} = (115V)(I_S + I_L)$$

In the present example, this is a loss of .230 watts, which is probably acceptable.

However, the value of a typical snubber used across SCRs in inverse parallel is 100Ω and 0.1 MFD. This impedance at 400 Hz is almost 4K, resulting in approximately 30 mA of leakage current. The power dissipation in the series resistor would be 0.09 watts.

<u>Leakage Current Range</u>	<u>Pass Section</u>
2 to 30 MA	SCR with snubber
.2 to 2 MA	Power transistors

The output shunt is required for safety for either transistor or SCR pass section in the SSPC. It is incorporated in the final proposed SSPC systems.

2.15 CURRENT SENSOR

A current sensing element is required to measure the load current, to enable the control circuit to determine whether or not a trip level has been reached. The devices considered for the current sensor were the following:

- a. RESISTOR - A resistor is inexpensive and reliable. Resistors also respond equally to AC and DC current, which is significant when half-wave loads are considered.
- b. TRANSFORMER - A current sensing transformer has a number of attractive features, particularly isolation and voltage gain. However, the response of the transformer to pulsating DC, which occurs for half-wave loads, is a serious drawback.
- c. HALL EFFECT DEVICES - Parameters not stable enough over the required temperature range.

Considering these factors, the resistor appears to be the best choice. The voltage drop across the sense resistor must satisfy the following conditions:

- a. The maximum voltage drop must not substantially increase the overall input-output voltage drop and the internal power dissipation at full load.
- b. The sense voltage at the maximum overload current (70 amps peak for a 5 amp RMS SSPC) must not saturate the base drive circuit in the transistor pass section SSPC.
- c. The sense voltage at 10% load current must be large enough for the load current status monitor comparator to operate with over the full temperature range of -55°C to $+125^{\circ}\text{C}$.
- d. The power dissipation at full load currents should not be more than a few watts for high current SSPC's.

THICK FILM POWER RESISTORS

Thick film low value power resistors are easily made using palladium silver or gold. These resistors can be part of the conductor pattern in a hybridized SSPC using transistors or SCR's. The TCR of a low value (20 milliohms) thick film resistor screened on an alumina substrate using Pd-Ag (palladium silver) is approximately $500 \text{ ppm}/^{\circ}\text{C}$. The maximum percent change in resistance, $\Delta R\%$ over the full military temperature range of -55°C to $+125^{\circ}\text{C}$ is the following:

$$R\% = \Delta T \times (\text{T.C.R.}) = 180^{\circ}\text{C} \times .05\% = 9\%$$

The optimum sense voltage was determined to be about 100 MV, so that for a 5A RMS SSPC the nominal resistance value is:

$$R_{\text{SENSE}} = \frac{100 \text{ mv}}{5A_{\text{RMS}}} = 0.02$$

The power rating of thick film resistors screen on a alumina substrate mounted a heatsink is 320 watts per square inch and several thousand joules of energy per square inch.

The 5 amp RMS SSPC current sense resistor will dissipate:

$$5A \times .1V = 0.5 \text{ watts}$$

The approximate area of the 20 milliohm resistor is 2500 square mils or the maximum allowable power dissipation is:

$$320 \text{ microwatts}/(\text{MIL})^2 \times 2500(\text{MIL})^2 = 0.8 \text{ Watts}$$

which is much greater than the actual 0.5 watts dissipated.

The peak power in the sense resistor during an overload is (50 ARMS) 50 Watts

If this overload lasts for 100 milliseconds, then the energy is only 5 joules, substantially below the maximum energy capability of the thick film resistor.

2.16 APPLICABILITY TO A DC SSPC

The block diagram of the DC SSPC is shown in Figure 16. The circuit configuration of the DC SSPC is the same as the transistor pass section with its MSI control circuit chips. Provisions must be made to

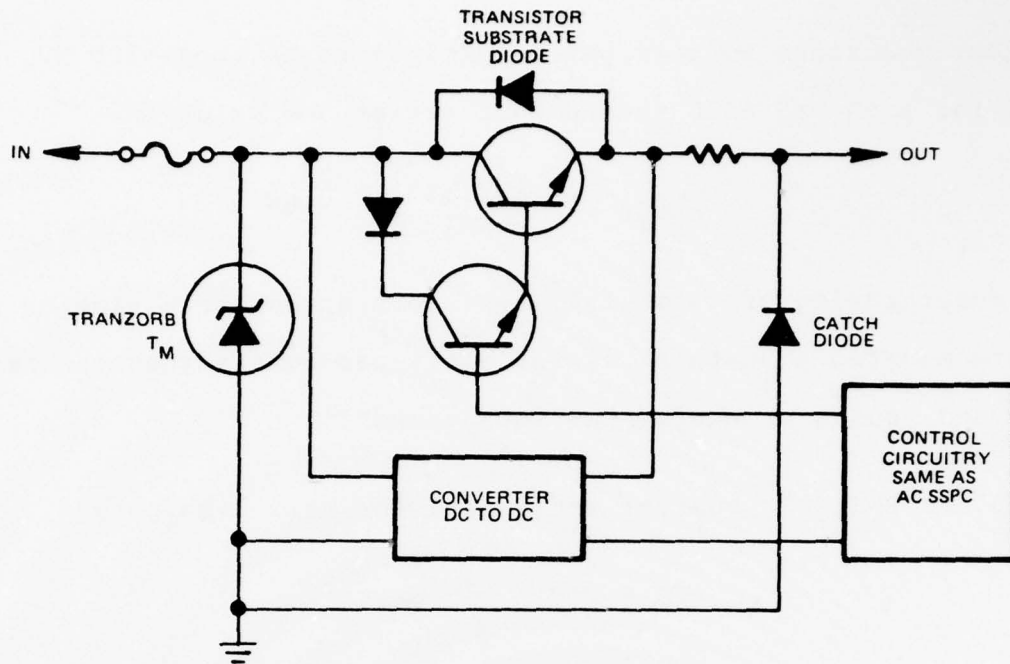

1778

Figure 16. Block Diagram of DC SSPC

absorb the " $1/2 LI^2$ " energy from the source and load inductances. This will be covered in Paragraph 2.16.1.

The DC input to the SSPC must be converted by a DC to DC converter to the same floating supply voltages developed for the AC SSPC. Figure 17 shows the basic circuit diagram for a single transistor ringing choke DC to DC converter, and Figure 18 shows the basic circuit for a push-pull transformer coupled DC to DC converter. The maximum output power required from the converter is approximately:

$$P(\text{OUT}) = 100\text{MA} \times 12\text{V} = 1.2 \text{ watts}$$

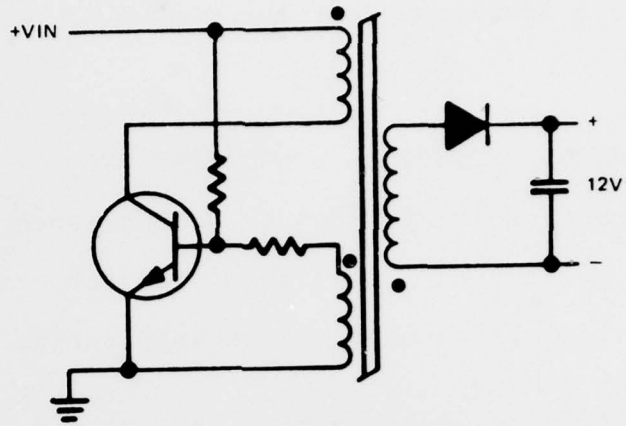

1779

Figure 17. Ringing Choke DC-DC Converter

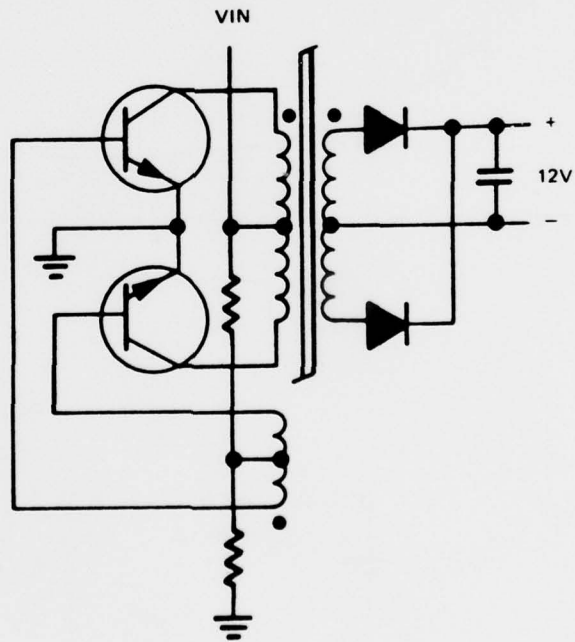

1780

Figure 18. Push Pull DC-DC Converter

The circuit efficiency of the ringing choke converter is 75% at the 1 to 2 watt level, whereas the push-pull DC converter is 85% efficient.

2.16.1 OVERLOAD PROTECTION CONSIDERATIONS

Overload current protection can be accomplished by limiting the load current to a maximum of 330% with a resistor or permitting the overload current to following the 1000% trip curve.

The current limit to 330% approach is analyzed first.

The graph in Figure 19 shows the current limiting characteristics of a single limit resistor.

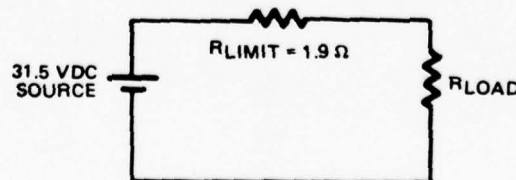
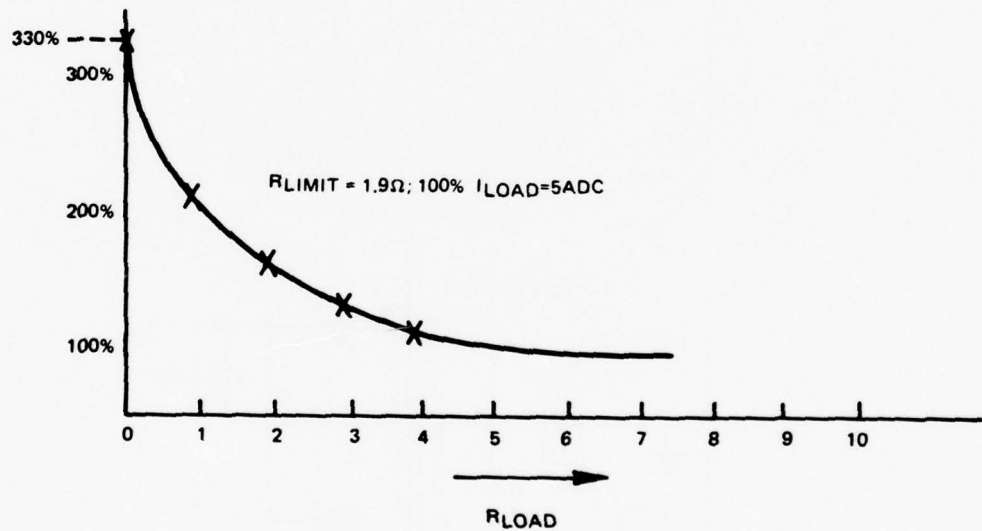

1781

Figure 19. DC SSPC Current Limit Characteristics

Refer to Figure 20 for DC SSPC current limit approach pass section.

The current limiting resistor required to limit the load current to 330% of rated current is:

$$R = \frac{V_{IN(Max)}}{330\% \times I_{(Rated)}} = \frac{31.5V}{3.3 \times 5A} = 1.9\Omega$$

So that I overload current = $\frac{V_{IN(Max)}}{R + R_{Load}}$

$$I_{O/L} = \frac{31.5}{1.9+0} = 16.5 \text{ amps or } 330\% \text{ of rated current}$$

$$= \frac{31.5}{1.9+1} = 10.9 \text{ amps or } 217\% \text{ of rated current}$$

$$= \frac{31.5}{1.9+2} = 8.1 \text{ amps or } 162\% \text{ of rated current}$$

$$= \frac{31.5}{1.9+3} = 6.4 \text{ amps or } 129\% \text{ of rated current}$$

$$= \frac{31.5}{1.9+4} = 5.3 \text{ amps or } 107\% \text{ of rated current}$$

$P_{(Resistor)} = I^2 R = (16.5)^2 1.9\Omega = 517 \text{ watts or } 517 \text{ watt-seconds energy requirements.}$

2.16.2 DC SSPC (1000%) INSTANT TRIP APPROACH

The maximum energy that the TransZorbTM in Figure 16 must dissipate is:

$$\text{Energy} = 1/2 (L_1 + L_2) I^2 \left[\frac{V_Z}{V_Z - V_{LINE}} \right] \text{ where } I = 10 \times I_{RATED}$$

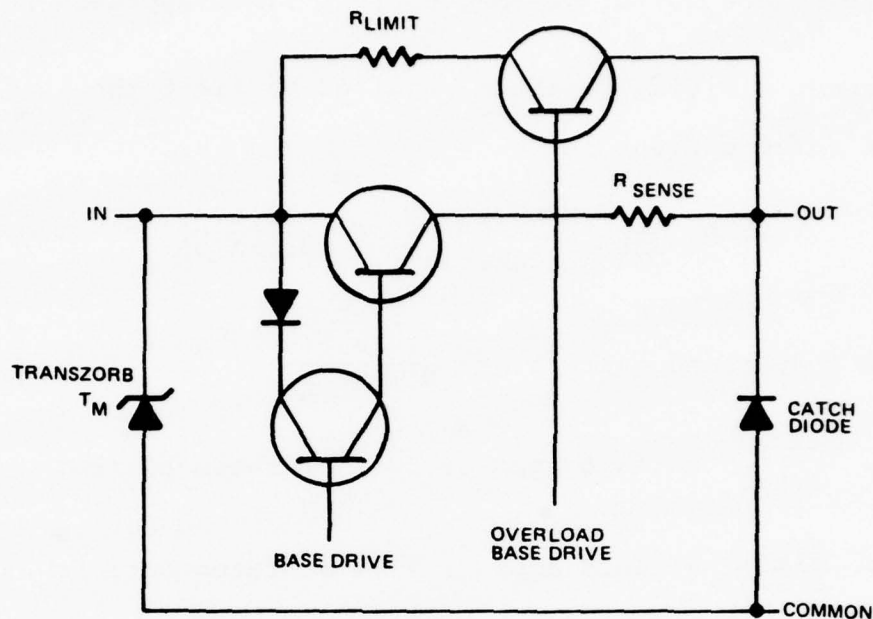

1782

Figure 20. Pass Section DC SSPC Current Limit Approach

Solving for L_1+L_2 to determine the maximum circuit inductance for reliable TranszorbTM operation:

$$L_1+L_2 = 2E(V_Z - V_{LINE})/I^2V_Z = 2 \times 5 (51-31.5)/(50)^2 \times 51 = 1.53 \text{ mH}$$

The addition of a catch diode would prevent energy from being fed back from the load allowing the line inductance limit to be 1.53 mH. However, with a relay coil as a load, the catch diode may increase the relay drop out time.

The pass transistor (s) would have to handle 50 amps with a $V_{CEO(SUS)}$ > approximately 70 volts. The equivalent circuit use in above analysis is shown in Figure 21.

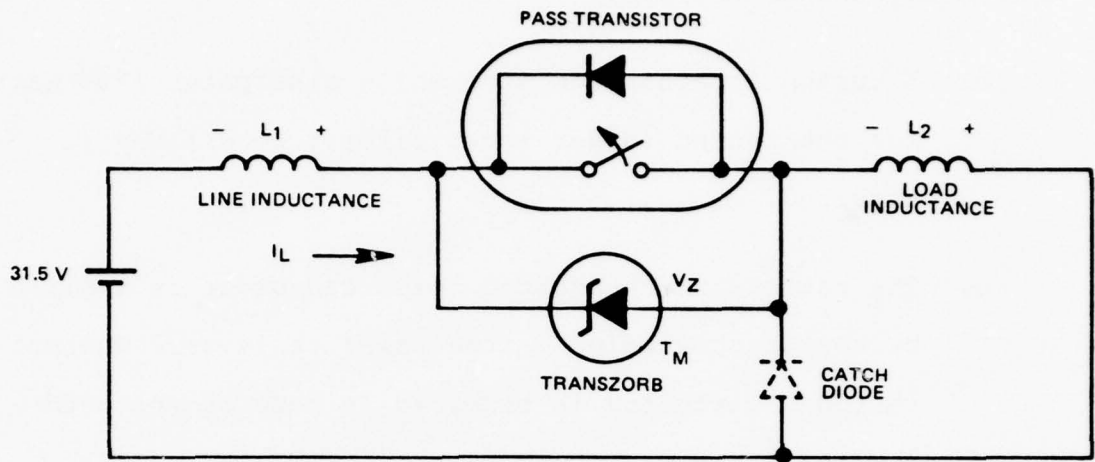

1783

Figure 21. Equivalent Circuit of DC SSPC Pass Section

The pass transistor base drive should not be applied or removed as a step function during SSPC turn on or normal turn off. Step changes in the DC load current can cause, depending on the source and load inductances, large voltage spikes and EMI problems. An integrator circuit is required in the low level base drive circuitry to provide the soft turn on and turn off control.

2.17 CURRENT LIMITING APPROACH

In the current limiting approach, which is discussed with respect to the pass transistor in Section 2.2, overload current is limited to 300% of the rated current. This considerably reduces the required transistor ratings by limiting the maximum transistor current to 21 amps instead of 70 amps.

This design approach was recently pursued in detail at Telephonics, in an independent design study. Some of the significant results of this study are as follows:

- a. A custom internal resistor which dissipates 1700 watts for one second (under short circuit conditions) is required.
- b. The rate at which shorted loads can occur is limited by heat accumulation in the power resistor. Thermal shutdown circuitry is required in case of repeated overloads.

The thermal analysis of a hybrid package using a current limiting resistor shows that the resistor may attain a surface hotspot temperature of approximately 520°C when mounted on a heatsink. The thermal division (decoupling) between the current limiting resistor and the control circuit components must be large enough to keep the maximum temperature of these components below 125°.

Refer to Figure 22 and, assuming no power dissipation on the control substrate.

The control circuit substrate temperature

$$T_2 = \left[T_{\text{AMBIENT}} + \alpha(520^{\circ}\text{C} - T_{\text{AMBIENT}}) \right] \leq 125^{\circ}\text{C}$$

where α is the thermal division factor between the control substrate and the current limiting resistor. The range of thermal division or decoupling for the type of hybrid construction is between 0.75 to 0.25 (1.33:1 to 4.0:1). Solving for T_{ambient} and assuming $\alpha = 0.25$.

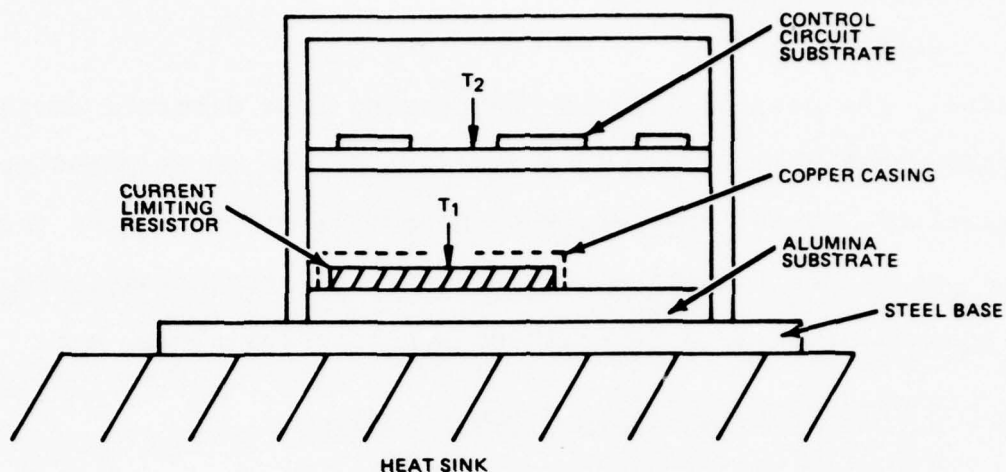

1784

Figure 22. AC SSPC Current Limit Approach Hybrid

Solving for α for a practical ambient temperature limit of 71°C , the required thermal division is:

$$\alpha = \frac{T_2 - T_{\text{AMBIENT}}}{T_{\text{RESISTOR}} - T_{\text{AMBIENT}}} = \frac{125^{\circ} - 71^{\circ}}{520^{\circ} - 71^{\circ}} = 0.12$$

or approximately 8 to 1.

This would be extremely difficult to achieve in a reasonable size hybridized SSPC. Reducing the maximum temperature of the limiting resistor to about 250°C by enclosing it in a copper casing will reduce the thermal division requirement to about 3.3 to 1 which can be done using the proper construction techniques.

2.18 LSI VS UNIVERSAL MONOLITHIC ARRAYS VS HYBRIDS VS DISCRETE
COMPONENT TECHNOLOGY

2.18.1 GENERAL

In general, the desirability of progressing from discrete components to hybrids to LSI monochips is a function of the anticipated production quantity. This, however, must be modified by the fact that certain components cannot be obtained with LSI technology, e.g. higher power transistors, large capacitors, accurate resistors, etc.

2.18.2 UNIVERSAL STANDARD MONOLITHIC ARRAYS

The use of Universal Standard Monolithic Arrays has significantly increased during the last few years because they combine the advantages of custom LSI without incurring the drawbacks of a large development cost and a long delivery schedule. While, they provide only about 80% of the packaging density available with the custom LSI, they provide far more flexibility for development programs and for construction of SSPC's of different types. The development nonrecurring cost is only \$3,000, which also includes 100 samples. Development times of 7 weeks for the first units have been achieved by Telephonics. There are multiple vendors in the field and they provide analog type chips as well as digital logic chips. Furthermore, they have been produced in large quantities and to MIL-STD-883B requirements. The production costs of the "monochip" units from Interdesign are about \$4.00 for standard MIL grade and \$8.00 for units meeting MIL-STD-883B requirements.

Telephonics developed five monochips in mixed DIP and flat pack versions for the present SSPC units developed for the Air Force.

These designs utilize standard patterns of components. Telephonics had only to provide a schematic and overall specification which just directed the supplier how to interconnect these standard components. Thus, there are no new layout problems for the vendor. For example, a typical chip which runs about \$4.00 in large production includes:

50 npn transistors

12 pnp transistors

various diodes

75 resistors

The best approach for medium production runs (which is consistent with normal buying philosophy for military programs) is that of utilizing monochip type chips included in hybrids with some special discrete components outside for the programmability function and because they cannot be readily handled inside the chip.

2.18.3 DISCRETE COMPONENTS

Telephonics has numerous production jobs utilizing discrete components on double sided printed circuit boards. On the 747 Passenger Service and Entertainment System we utilized cordwood construction techniques wherein tightly packaged components were strung between two small printed circuit boards. Although this increased the component density, it posed reliability, maintainability and repair problems. This is not recommended for use. The use of normal densities of components on printed circuit cards is one of the recommended techniques. The assembled components are then

soldered using automatic wave soldering techniques. This approach represents the least expensive approach, especially when combined with the use of monochips.

A quad SSPC card was recently priced for production runs. It revealed that only 10% of the cost was attributed to the assembly and test time. The manufacturing techniques did not even utilize automatic insertion machines. It is thus clear that the acquisition cost of components is clearly the main item in determining the overall SSPC price. The reliability of the discrete component approach will be the lowest of the candidate versions. It will also pose more problems in maintainability since the separate components dictate more test points to achieve fault isolation to the component or small functional group of components. However, the cost of repaired components is the least expensive since only the failed item itself, rather than the whole hybrid or LSI, need be replaced. Obviously, the development time and development cost are a minimum as are problems in availability of multiple vendors.

2.18.4 HYBRIDS

Our experience in hybrids is that they should be used only where size and weight minimization are of extreme importance. They are generally more expensive in production than the equivalent discretized with the associated labor. They also require 3-6 months for development time and cost \$5,000.00 to \$10,000.00 for medium complexity units including iterations. Also, although the theoretical reliability is higher than the discrete equivalent reliability, problems are often encountered in the initial runs. The manual

labor in the hybrid itself is more than that of the discrete version because wave soldering techniques can't be used and the insertion area is much smaller and harder to work in. However, some labor is reduced because certain components such as resistors can be deposited automatically on the substrate.

Because of the above, the recurring cost of hybrids is usually 25% to 50% more than the equivalent discrete version for normal military grade components. However, the costs are about equal if high reliability discrettes, conforming to MIL M38510 Class B, are involved. This occurs because the hybrid vendor uses a normal military grade chip and they employ MIL-STD-883B inspection and test criteria on the whole device. This is much less expensive than purchasing each of the components to the full hi-rel requirements. Thus the overall costs become about the same.

The repair costs for hybrids are higher than the discrete version because, although the discrete versions require more fault isolation, the cost of the single part is much less than the whole hybrid.

The reliability of the hybrid is higher than the discrete version because the number of connections is reduced.

2.19 THREE PHASE SSPC UNITS

Three phase SSPC units used to control the power to three phase loads, may vary from simply configurations with three single phase power controllers with common E-MUX control to special configuration devices with heavily modified power controllers.

The complexity of the three phase power controller is determined by the type of load to be encountered. For a heavily inductive load, the rise times are limited, therefore the simplest arrangement will suffice. For such a load, as might be found with a three phase motor, a power controller unit in each load leg can turn on all three phases, preferably when the voltage VAB is zero. Although, a voltage will be present, in phase C, the retarded current rise avoids a disturbing transient. For turn off, a slightly different procedure is used. When the current in phase one is zero, that phase is turned off. The controller pass element is turned off in the other phases when their current is zero.

If it is desired to change the direction of the motor when used in the simple three phase configuration, two additional pass elements must be added, giving a total of five.

This simple configuration system has been set up and demonstrated at Telephonics with B-1 SSPC's (which were designed for 230 volts, single phase) adapted to 115 volts with a three phase 400 Hz 1/6 HP motor.

Demonstration of the simple configuration system showed that when the cut-off time was set to agree with the current cross-over point, there would be no voltage spikes.

Further consideration of the situation shows that to make improvements leads to more complex circuitry. For example, if it is desired to turn on the third phase of the three phase load at the zero voltage cross-over, it is necessary to wait for 90° . This can

be seen in Figure 23, which indicates that the phase C + to - crossing takes place 90° following the - to + crossing of the voltage V_{A8} . Reference to Figure 24 shows a typical arrangement of three SSPC's with a "Y" load. Two modifications from the simple 3ϕ circuit are obvious: A sequencer control to provide turn on and turn off as described above and an alteration in the transformer which drives the internal SSPC power supply so that it can be operated either from the three phase supply or from one of the phases.

Other alternative configurations such as shown in Figure 25 are under consideration in order to simplify and reduce the number of parts. Turn on of each leg can take place slightly ahead of the voltage cross-over points with positive slopes starting with leg 1 phase A (V_{12}), then leg 2 (V_{21}), and finally leg 3 (V_{31}).

SSPC turn off can take place in the reverse sequence with each leg's base drive removed when its pass transistor is normally not conducting load current. Thus critical timing and zero current sensing circuits are not needed. This is basically the approach used in the single phase power controller, outlined in Paragraph 2.8.1.

The phase A load current will flow only after phase A pass element is turned on and this current will flow through phase B or phase C or both depending on the polarity of V_{AB} and V_{AC} . Phase B pass element is turned on next and phase B load current can flow. Finally phase C pass element is turned on and load current is allowed to flow in all three phases. The turn on control signal to each pass element is applied only when it is normally not conducting during the negative part of the phase voltage cycle. This allows

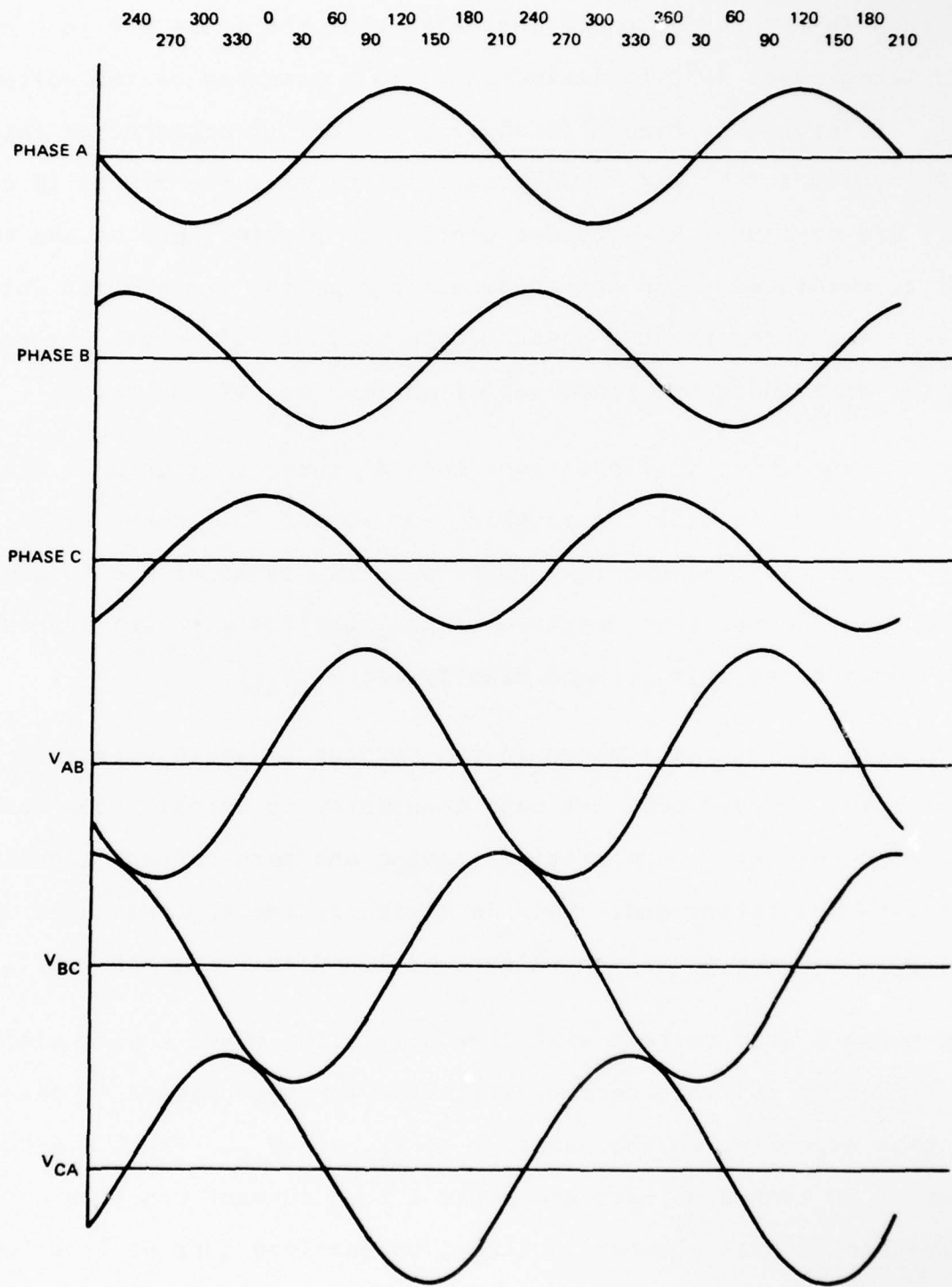

1785

Figure 23. Three Phase Waveforms

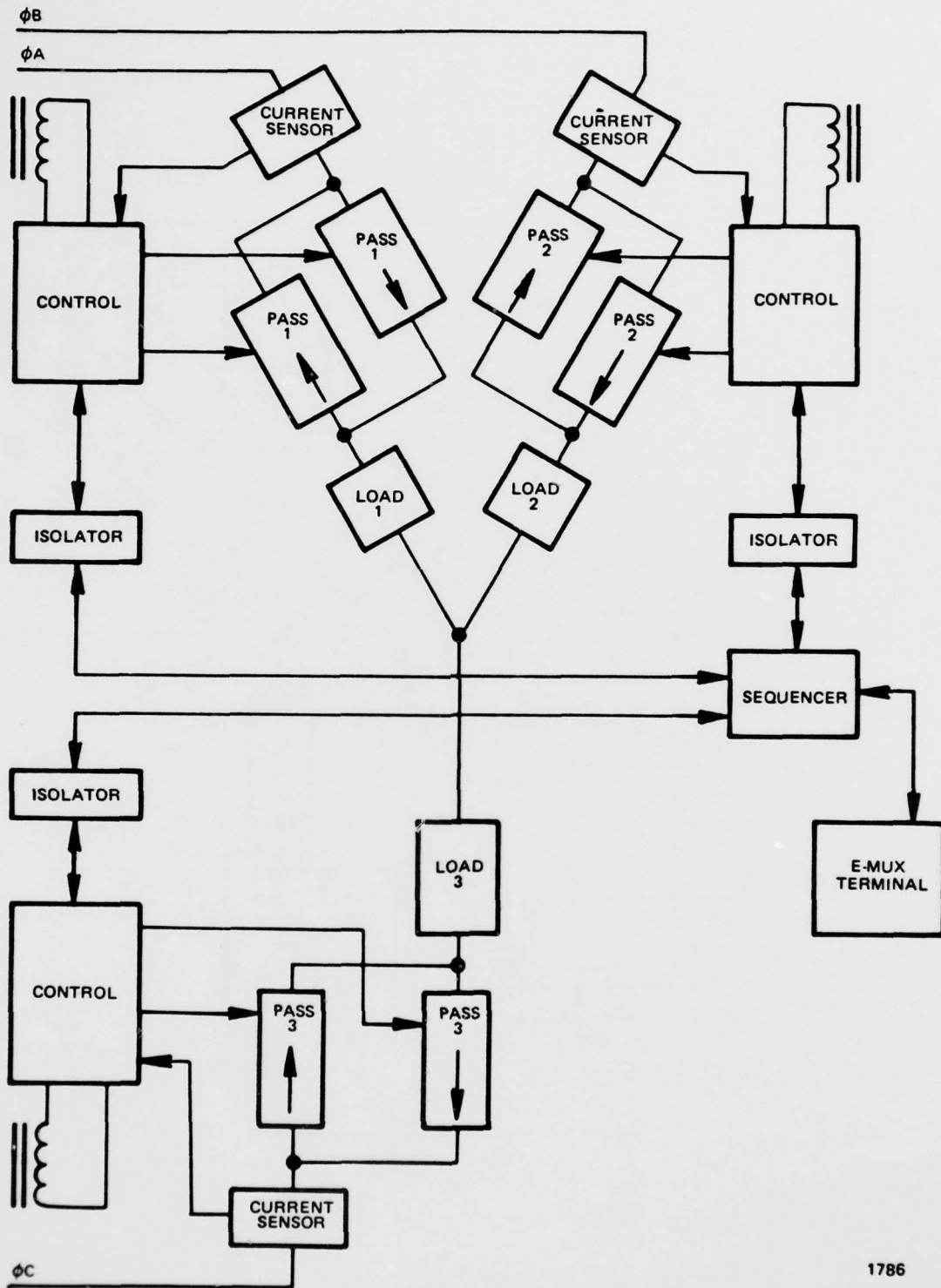

1786

Figure 24. Simple "Y" Configuration

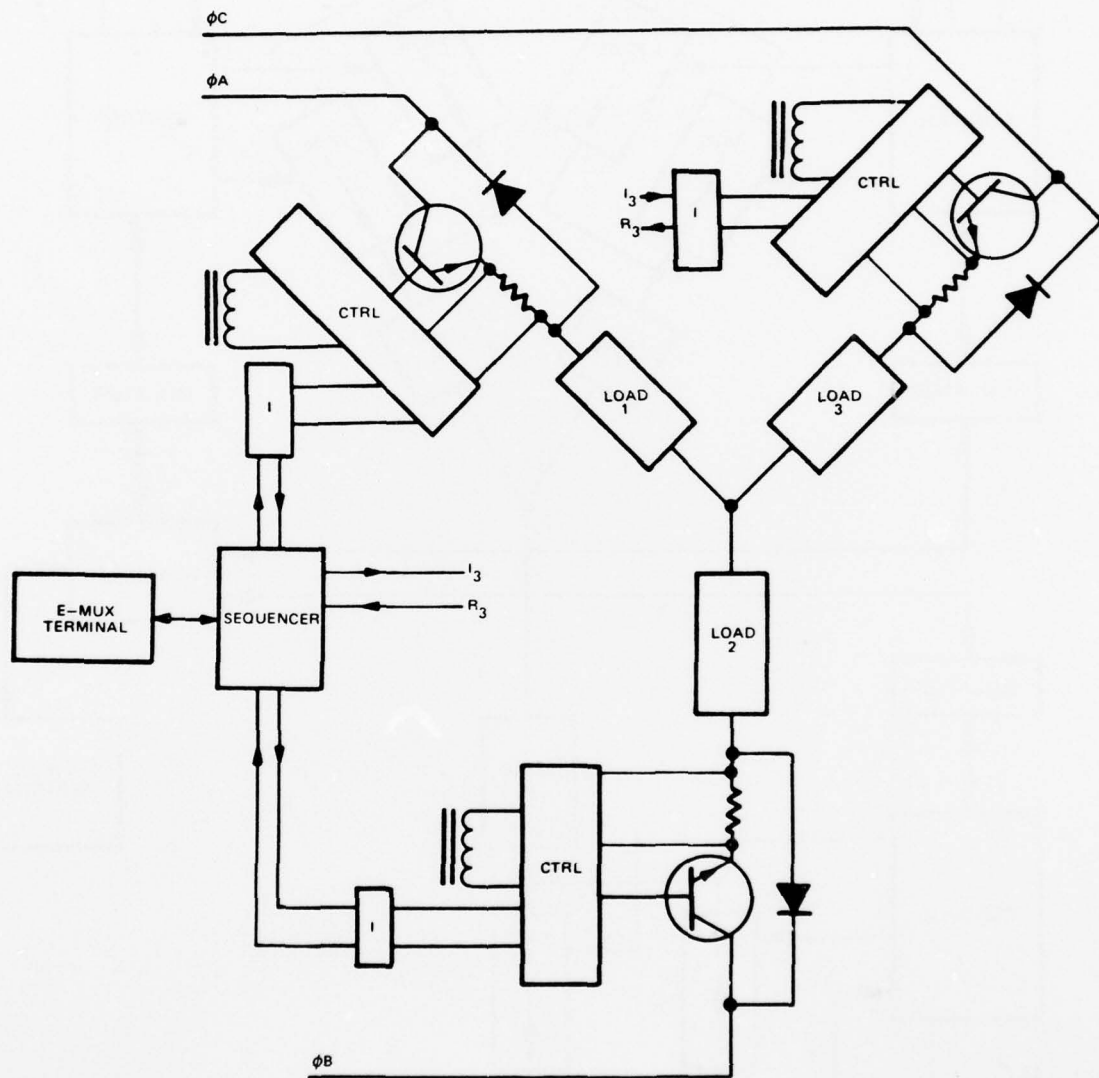

1787

Figure 25. Alternate Circuit Configuration Using Less Complex Pass Section and Timing Circuit

the pass element to start conducting at the zero crossover point in the positive cycle. This entire procedure is reversed for turning off the controller. This configuration is most useful as motor controllers or whenever balanced 3 ϕ load are used.

2.19.1 THREE PHASE BIAS TRANSFORMER AND POWER SUPPLY CONFIGURATION

The 3 ϕ SSPC bias voltage transformer configuration required is shown in Figure 26. The transformer is designed to provide the minimum required voltage at each secondary winding to operate the control circuitry with only two of the three legs energized. This means that the voltage regulator will have to dissipate extra power when all three phases are operating. The transformers may be wound on a single core or consist of three separate transformers with the primary wired for a delta connection.

2.20 TRIP CIRCUITS

Protection of the aircraft wiring and of controlled circuits is accomplished by turn-off of the SSPC when excessive load current is drawn. Using circuit-breaker terminology, this kind of turn-off is referred to as a TRIP condition.

The way in which the trip characteristics are established is by reference to the wire "smoke" curve which is the time at which the aircraft insulation will fuse or ignite for a given current passing through it. The turn-off or trip time for a given load current is then kept shorter than the equivalent time shown for the same current in the "smoke" curve.

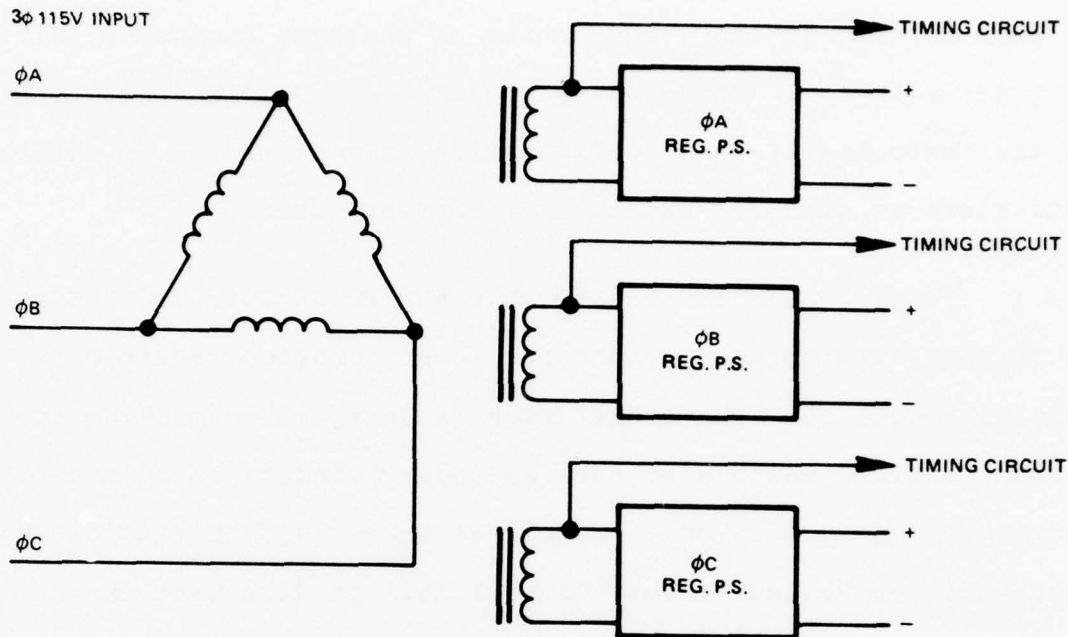

1788

Figure 26. Bias Transformer and Power Supply Configuration for 3 Phase Operation

A further modification is introduced by a fail-safe device (usually a fuse link) which increases the protection, but having rather large tolerances, forces the SSPC trip time curve to much shorter turn-off times.

There are three classes of trip circuits that have been studied at Telephonics:

1. Time Trip - used for small and moderate overload currents.
2. Current Limiting - used for heavy overload currents.
3. Instant Trip - used for heavy overload currents.

TIME TRIP

The Time Trip circuit has the purpose of shutting off the SSPC for mild overload conditions. The characteristic will lie between the rated load current and the wire insulation "smoke curve". The time trip characteristic is further restricted when a fuse link is used. It has to be less than the blow time of the fuse so that replacement of the SSPC or the fuse will not be required except for very rare instances. It is desirable to have the trip time sufficiently high so that the choice of a SSPC with an appropriate rating for steady-state conditions will still be valid for loads with transient overloads. This is obviously the case for an SSPC controlling incandescent lamp load where the inrush current may exceed the steady state current by a large factor.

LOAD DETECTION

While there are a number of techniques for detecting and measuring the load current within a SSPC, the use of a resistor still is the most economical and leads to as great an accuracy as is needed. The only debatable point is whether two resistors or a single resistor is preferable. The two resistor system arises if used in bridge circuit where the positive half-cycle is distinct from the negative half cycle. For the single resistor system full wave rectification takes place. This has the advantage, which is a major one in practical hardware design, of only requiring a single rail power supply. The dual resistor system may require a double rail power supply but it has the advantage of not being disturbed by current splitting if pass elements do not sufficiently "open" in the reverse polarity case.

With the choice of satisfactory pass elements, the single "sense" resistors provide simpler, more reliable load detection and measurements.

For setting up the "sense" resistor system, the compromise is made between the value necessary to get a reasonable voltage to measure with sufficient precision, and the need to keep the voltage drop quite small.

The load current, as passed through the sense resistor, is represented by the voltage - and this in turn must be used in a computation of the time to trip for any particular overload.

The "smoke" curve and the fusion characteristic of fuse metal will be a function of the energy supplied to the wire or device, giving the well known i^2t relation for higher power. For lower powers, the thermal losses (such as by conduction through the leads) prevent the wire or device from ever reaching the charring or fusion temperatures.

The characteristic for a power controller time trip circuit should be:

- a. Fairly accurate in determining the minimal overload point. This determines the maximum steady state rated load current and although the trip time itself is not very critical at this point, the tolerance of measurement of overload is important. For example, if the tolerance of measurement of load current is $\pm 10\%$, then the SSPC rated load of 100%

means that the minimal trip overload cannot be set under 111%.

- b. As the overload increases, the characteristic tends toward the I^2t curve. But because it is not necessary to consider any more than about one decade of load current over 100%, the I^2t function is easily approximated by linear functions.

The inrush current for incandescent lamps is one important consideration for transient overloads. When operated from DC power supplies, or even AC when the turn-on can be at the line voltage peak, the inrush current of incandescent lamp loads might be as high as 12 times the steady state conditions. However, when the turn-on takes place at the voltage zero-crossing on a 400 HZ line the inrush current does not exceed six times the steady state load current for the first half cycle. Another important consideration for transient overloads is the turn-on of the AC into a power supply with a rectifier and a large capacitance as in Figure 27. The initial charging of the capacitor becomes a large surge current load for the power controller.

Therefore the capability of operating with the time trip up to the 1000% of rated load current is quite inclusive, leaving a large margin to cover effects that might lead to nuisance trips, yet not require de-rating.

In the past history of circuit breakers and other protective devices, the idea of an inverse function has predominated over the idea of the I^2t function. This happens, to some extent, because

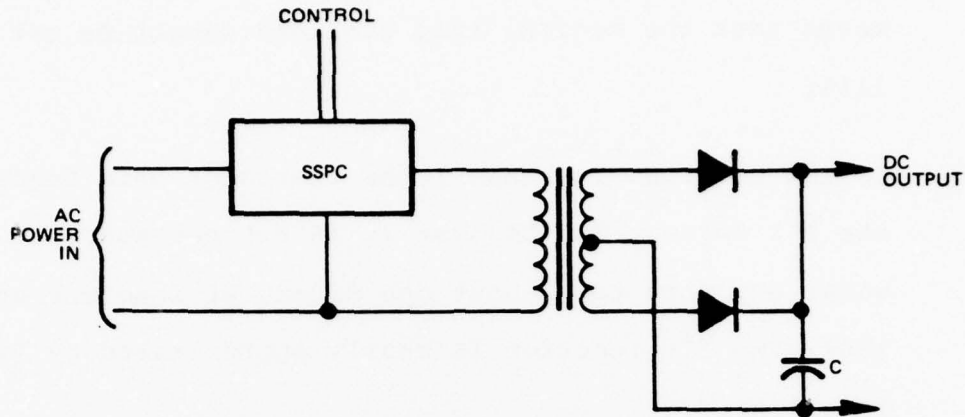

1789

Figure 27. Full Wave Power Supply as Load for SSPC

the transition from "never blow" or "never trip" to the I^2t function is usually well represented by an inverse relationship of the form:

$$\text{TRIP TIME} = \frac{K1}{\text{overload}} - K2$$

where $K1$ and $K2$ are constants.

This relationship is desirable because of the simple circuits (mechanical devices for circuit breakers) that can be used to solve for Trip Time.

CIRCUIT TYPES

A number of ways of doing the hardware computation to determine the trip time for a particular overload are known to designers, the oldest and most direct way being by analog circuit. Almost all of them depend on the charge storage of capacitors to provide

the timing feature. Some of the methods showing promise or advantages that were studied by Telephonics are:

Analog Trip Circuit

Digital Trip Circuit

Mixed Trip Circuit

ANALOG TRIP CIRCUIT

The Time Trip Circuit, in analog designs, in essence consists of a voltage to current converter, a storage capacitor, adders, a voltage reference and a comparator. This is indicated in the Figure 28 which is shown for the single sense resistor system.

A variant of the above system is a multiple step overload reference and V to I converter circuit to charge the capacitor at several different rates depending upon the overload. This allows the extension of the time trip characteristic into higher decades of overload.

DIGITAL TRIP CIRCUIT

The Time Trip Circuit in Figure 29 is a digital design. It consists of an analog to digital converter, an oscillator-clock circuit, a digital integrator, a digital comparator and a controller circuit. Despite the term "digital", a digital time-trip does have to depend on some analog components. The clock may be controlled by an R-C circuit to perform the timing and the A-D converter does have certain linear components.

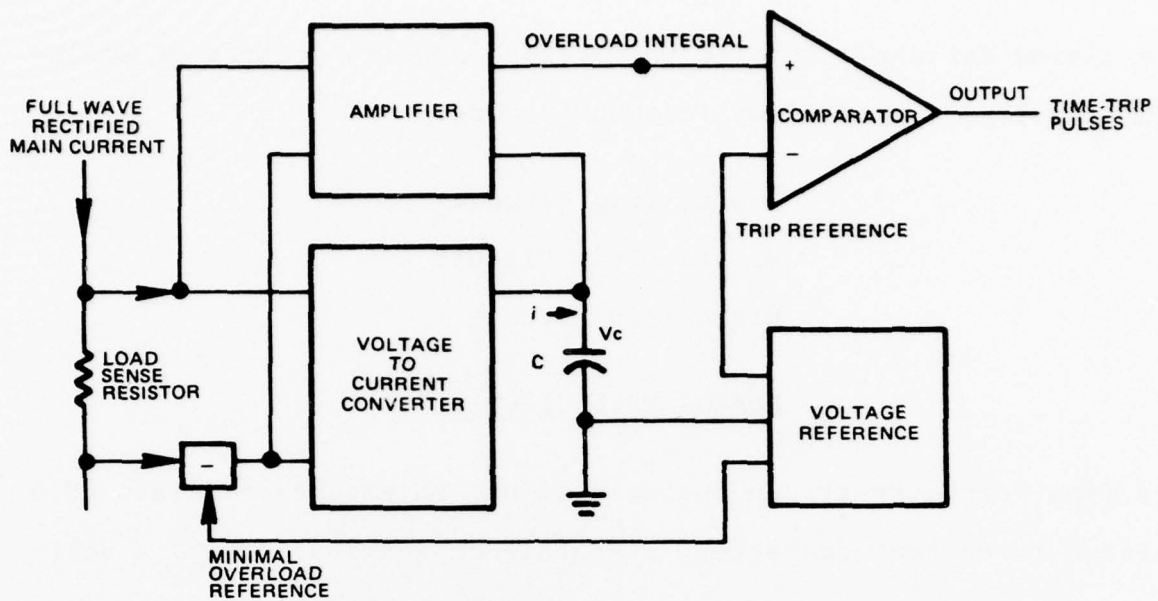

1790

Figure 28. Block Diagram of Typical Analog Time Trip Circuit

There are some digital devices which would be used on various power controllers whether or not the trip circuits are digital or analog. One of the important ones is the trip latch. This is needed to hold the trip condition from the time the excessive load appeared as a pulse until a reset action has been taken.

MIXED ANALOG AND DIGITAL DEVICES

It was pointed out in the previous discussion that it was difficult to have a pure digital or pure analog trip circuit because the concept of timing and current measurement are essentially analog ideas while the trip latch is a digital idea.

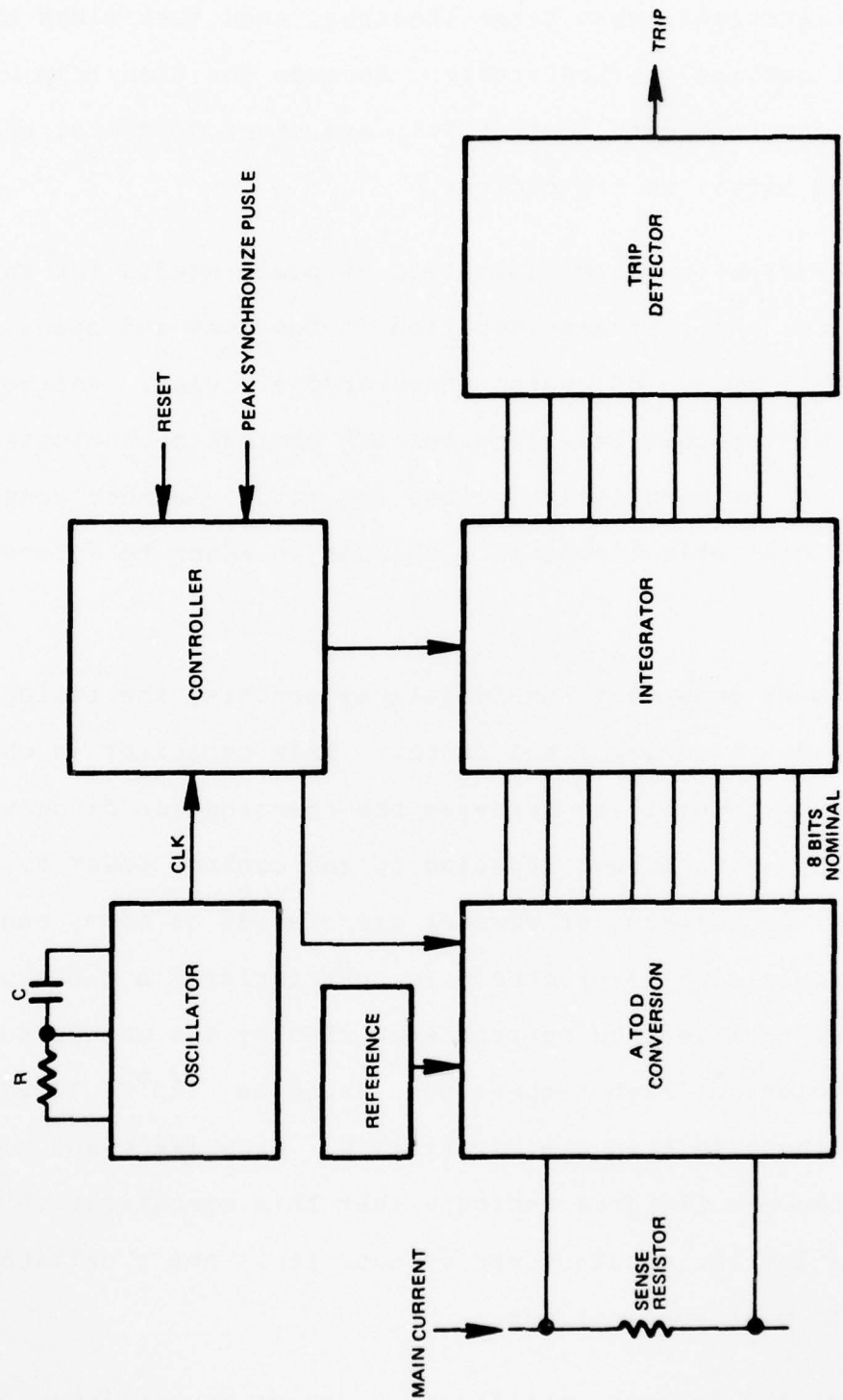

1791

Figure 29. Block Diagram of Typical Digital Time Trip Circuit

Other considerations, when taken together, show that mixed analog and digital devices are preferable. Because the time trip circuitry can be combined with Instant Trip and other circuits, these also have an effect on the choices.

One consideration is the minimization of power needed for the control circuits. Another consideration is the cost and space reduction available by use of custom integrated circuits. Another consideration is the cost relations for the various technologies with which discrete or monolithic devices are made. Another consideration is the cost effectiveness of changes to adapt to future systems.

One of the most important considerations concerns the timing capacitor if space is an important factor. This capacitor is chosen to be as large as possible to decrease the charging (or discharging) current which has a direct relation to the control power to be dissipated. Capacitors, of several microfarads or more, can only be a reasonable size if electrolytic, particularly a tantalum device. These have leakage current specified by the manufacturer to be sufficient at high temperatures (such as $+125^{\circ}\text{C}$) to somewhat alter the time trip characteristics. Experience and consultation with the manufacturer indicate that this specification is overly safe for the manufacturer because it is not a critical parameter in most applications.

Avoidance of the leakage specification can be accomplished by using smaller capacitors, which can be ceramic types. However,

in order to avoid drawing heavy current in order to get the long Trip Times, it is necessary to use the capacitor for the timing of an oscillator so that the pulse repetition rate provides the function of the sense resistor current. The oscillator signal, so generated is then divided down and the result may be added to a digital signal obtained from an analog to digital conversion of the output signal. Other variants are known and have been implemented.

If no leakage existed, every transient overload would continue to change the capacitor when used in the direct time designs. In the oscillator design, counting up would also lead to a similar effect. For practical use, any Time-Trip circuit must be allowed to return to the zero or idle state if continual transient overloads do not exist. Addition of "controlled" leakage or of providing a "down count" for the digital counter are ways that are used to accomplish the reduction of time accumulation when sufficient overloads do not exist.

INSTANT OR FAST TRIP

When the overload exceeds the requirements for any normal load surges, it is necessary to try to turn off the power before the full cycle is completed in order to protect the wiring or other equipment.

The speed of turn off becomes a function of the type of component used to control the main power. Obviously, a TRIAC or SCR can only turn off at a Zero crossing. Therefore, the fastest turn off might be as long as a half cycle (1.25 msec). The SCR or TRIAC circuits

may therefore require the sustaining of high energy dissipation until the turn off can occur. This type of turn off is often referred to as "Fast Trip".

With a transistor type pass component, the turn off is measured in microseconds and is called "Instant Trip". The turn off delay for a transistor is usually determined by the storage time of the transistor, which is far smaller than the times that can be encountered with other devices. This is discussed with more detail in other sections.

In any event of great overloads, the detection of the excessive load current must lead to the setting of a trip latch so that a definite turn off is held. If this were not done, Instant Trip turn offs would be followed by turn ons giving rise to a possible power dissipation problem.

CURRENT LIMITER

An alternative to the Fast or Instant Trip is the current limiter which provides a maximum current condition until the SSPC can be turned off at the usual zero crossing time.

The detection of load current exceeding a set value would set the Current Limit Latch which replaces the Instant Trip Latch. One version of this would insert a resistance in series with the load while initiating a turn off sequence. A particular version had several comparison levels detected, and the series resistance changes according to the level detected, so that the current limiting was approximated by several steps.

AD-A063 405

TELEPHONICS CORP HUNTINGTON N Y
ADVANCED SOLID STATE POWER CONTROLLER DEVELOPMENT. PHASE I. STU--ETC(U)
SEP 78 R J EDWARDS

F/G 10/2

F33615-77-C-2017

UNCLASSIFIED

AFAPL-TR-78-55

NL

2 OF 5

AD
A063405



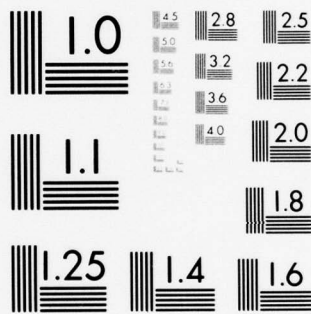

MICROCOPY RESOLUTION TEST CHART
NATIONAL BUREAU OF STANDARDS-1963-A

2.21 LOAD COMPATIBILITY

Several classes of loads exhibit features which affect various aspects of the SSPC design. Some of these considerations are as follows:

2.21.1 CAPACITOR LOADS

For several valid reasons (EMI, stored inductive energy, etc.) it has been decided to employ zero current turn-off (ZCTO). In a load which is purely capacitive, a zero current corresponds to maximum voltage. Thus, when the SSPC turns off, the capacitor is left charged to the full peak voltage. This can cause at least two problems: first, the transistor pass peak-to-peak line voltage, which for a nominal 115 VAC line, is approximately 509 volts.

This load (purely capacitive) has a power factor of 0. For more reasonable power factors, closer to 1, the voltage seen by the pass elements is somewhat less than these values. In any case, the pass element must be selected to withstand this voltage. The second problem is that the capacitor is left with a residual charge, and the discharge path should be considered. If no other path is available, the only discharge path is the SSPC output shunt and status circuit. The status circuit will, therefore, indicate positive status until the capacitor voltage discharges down to a low level. This discharge time may be significant, since a FAULT will be indicated to the EMUX terminal.

Additional potential problems can occur turning on into capacitive loads, particularly if zero voltage turn-on (ZVTO) is not used. In

this case, the peak current is limited only by the small series impedances exactly as in the case of a shorted load, regardless of the value of the capacitor. The value will determine only the rate of decay of the current. For ZVTO, however, the current is fundamentally limited by the value of the line impedance. Without ZVTO, however, virtually any small capacitor can cause inrush currents of any value, limited only by "stray" impedances.

2.21.2 CAPACITOR INPUT FILTER POWER SUPPLIES

Capacitor input filter power supplies have large inrush currents on initial power turn-on. Switching regulators, similar to the one shown in Figures 30 and 31 will produce the greatest inrush currents on power turn-on, because unlike a 400 Hz dissipative regulator with an input transformer whose DC resistance and leakage inductance can help limit the peak inrush current, only the rectifier impedance and circuit wiring act to limit this inrush current. Measurements of a typical switching regulator power supply operating directly off the 400 Hz line without an input transformer shows that it can have a peak inrush current at turnon that is 34 times the peak repetitive line current. This high peak current only lasts for a half cycle, however, the power controller will instant trip for currents that exceed 1000% of the rated load current. Switching regulator used with SSPC should be selected with inrush currents less than 10 times the SSPC rating and compatible with the time trip curve.

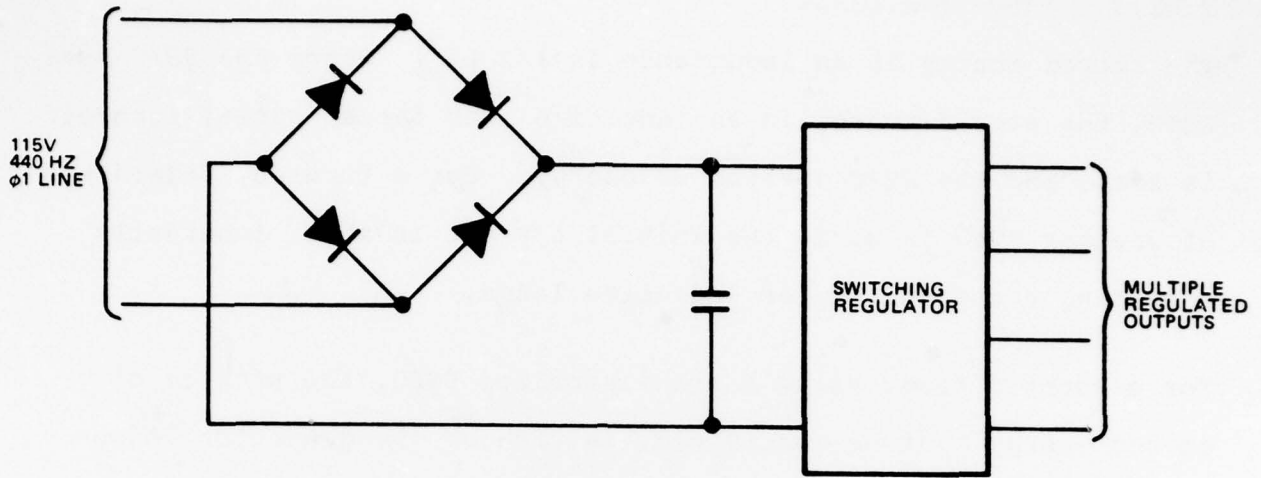

1792

Figure 30. Single Phase Line Operated Switching Regulated Power Supply

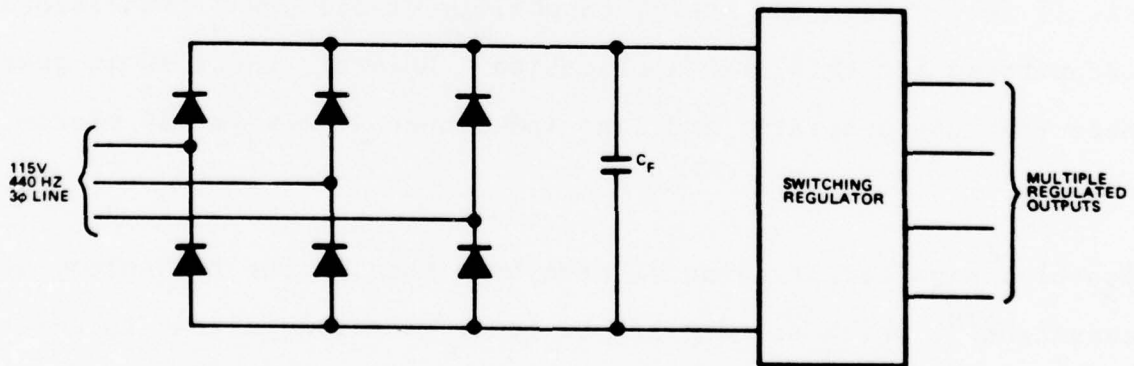

1793

Figure 31. Three Phase Line Operated Switching Regulated Power Supply

2.21.3 INDUCTIVE LOADS

The stored energy in an inductance is $1/2 LI^2$. Since the SSPC uses ZCTO, the stored energy in an inductive load for a normal turn-off is zero, and the SSPC absorbs no energy. For a turn-on, regardless of whether ZVTO is used, the initial current is zero, inherently providing a soft start for inductive loads.

For a shorted load, using a transistorized SSPC, the problem of stored energy must be considered, in view of the generator inductance. The transistor goes into the sustaining mode, as discussed in section 2.8.1, and all of the energy stored in the generator inductance is dissipated by the transistor. For 50 microhenries and 70 amps, this energy is:

$$\begin{aligned} 1/2 LI^2 \left[\frac{V_{CEO(SUS)}}{V_{CEO(SUS)} - (V_{LINE(PK)})} \right] &= .5(50 \times 10^{-6})(70)^2 \left[\frac{400}{400-250} \right] \\ &= .327 \text{ joules.} \end{aligned}$$

This is well within the energy capability of all power transistors contemplated for this SSPC application. However, there is no guarantee that the generator and line inductance is always <50 microhenries.

Recently, significant advances have been made in the technology of TransZorbsTM, which are similar to power zeners, designed to absorb very large energy surges. One particular unit made by General Semiconductor Industries, which is now in production, was evaluated during this study program and found to have excellent characteristics, including low temperature coefficient and low leakage at low voltages. These devices can be used with transistor pass sections

to absorb energy surges from the source or load inductances during non ZCTO conditions (instant trip). Source inductances over 50 microhenries will require an energy absorbing device (TransZorbTM) to protect the transistor pass section.

See Figure 32 for pass section schematic using TransZorb for protection. The transzorb is selected to have a breakdown voltage less than the minimum VCE (Sustaining) of the pass transistors and higher than the maximum voltage dictated by the power source.

The energy dissipated in the transzorb can be calculated as follows:

$$\text{Energy}_{(\text{TRANSZORB})} = 1/2 (.25 \times 10^{-3}) (70)^2 \left[\frac{280}{280-254.6} \right] = 6.75 \text{ joules}$$

For a 5 amp SSPC used in a 115 VAC 400 HZ aircraft power system, the following is assumed for this illustration:

V source = 180 VRMS maximum = 254.6V PK maximum

L source = 0.25 millihenries

1000% overload current = 70 amps peak

V clamp = 280V (TranszorbTM)

2.21.4 LAMP LOAD

An incandescent lamp is simply a nonlinear resistor, and contains no stored energy to be dissipated at turn-off.

With zero voltage turn on, the lamp draws an inrush current of from 200% to 700% of its rated current, depending on the lamp

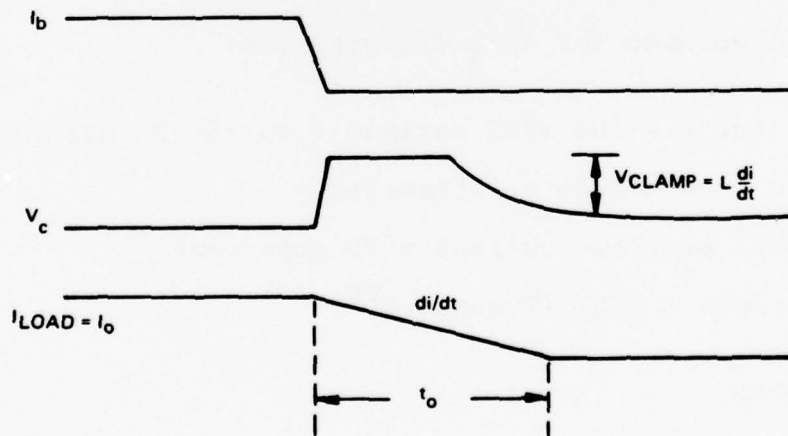
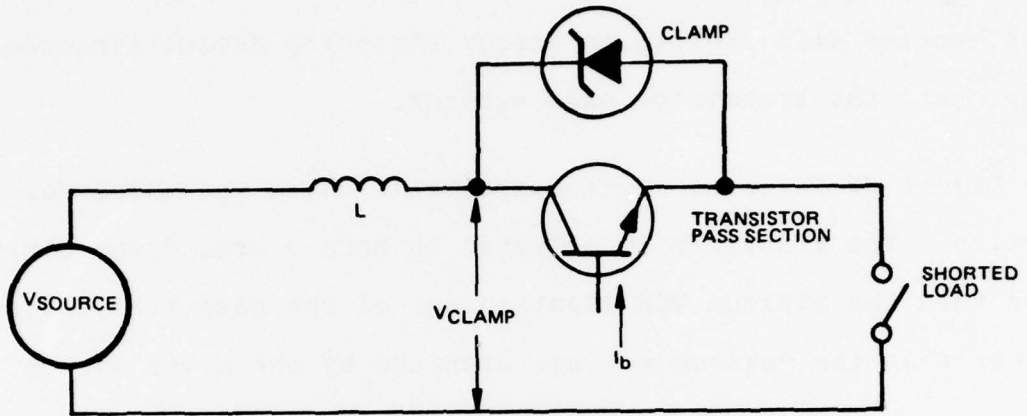

1794

Figure 32. Transistor Current and Voltage Waveforms During Instant Trip

characteristics and temperature prior to turn-on. The SSPC trip curve is clearly designed to accommodate this, and no problem for the SSPC is encountered with any proposed design approach. Whether the life of lamps can be extended by use of 300% current limiting is debatable. It has been known that for many lamps, constant current sources can reduce the life to about half of that from constant voltage sources. The 300% current limit condition may be considered as a mixture of the two source types. Furthermore, since the lamp life is extended by ZVTO, the proposed AC SSPC configuration is closer to the ideal controller for lamps.

2.21.5 MOTOR LOADS

Startup of motors is no particular problem with an SSPC using either SCR's or transistors with 1000% trip, assuming that the motor characteristics comply with the SSPC trip curve.

Startup may be a problem in some cases with current limiting at 300%, however. Certain motors with certain loads may start more slowly, or may stall and not start at all. This is a serious drawback, and precludes the 300% current limiting approach.

Another problem associated with motor loads is the back EMF generated subsequent to turn-off, as the motor is coasting to a halt. The frequency of the generated voltage is continuously decreasing, so that peaks of the back EMF will periodically be 180° out of phase with the 400HZ line. At these times, the pass element may see the peak-to-peak line voltage, similar to a capacitor load. With ZCTO this voltage will only last for a few cycles, however, with non ZCTO the motor may act as a generation for a much longer

time. This would increase the energy absorbing requirements for the pass section elements.

2.21.6 HALF WAVE LOADS

A significant impact of half-wave loads is to favor a resistor as the current-sensing element instead of a current transformer.

For transistorized SSPC's, half-wave loads pose no special problems. For SCR's, however, inductive half-wave, and even inductive full-wave DC loads, can present a serious problem. For a large inductance, with a large DC component, the DC current tends to continue flowing, and the SCR does not self-commutate. Current continues to flow from cycle to cycle, and the SSPC can not be turned off by normal means. The most common means of preventing this problem is to specify that a "free-wheeling" diode must be connected in parallel with the inductive load.

2.21.7 ELECTRO-EXPLOSIVE DEVICES (EED)

The EED as described by the Vought Corporation final report, has uncontrollable impedance during ignition, lasting up to 10 milliseconds. After ignition, the EED impedance could go down to zero ohms, causing the overload current to exceed the 1000% rated load current and produce an instant trip. This would be acceptable providing the EED current requirements remain below the "must not trip" portion of the SSPC trip curve before ignition occurred.

2.21.8 COORDINATION OF CASCADED POWER CONTROLLERS

The diagram in figure 33 shows how several SSPC's can be connected for circuit breaker protection of several small loads powered from the main power bus. If a load fails and shorts out, its SSPC will reach the trip current threshold first and trip out before the main SSPC does. However, if a SSPC fails (shorts) and the load also fails (shorts,) then the main SSPC may trip depending on whether the fail-safe fuse in the failed SSPC opens before the main SSPC "must trip" portion of the time curve is reached. If the 2 amp SSPC fails into a shorted load, its 5 amp fail-safe fuse ($2\frac{1}{2}$ x rated current) could take a few milliseconds to clear allowing the fault current to rise up to 50 amps, causing the main SSPC to trip. In the case of a 0.5 amp SSPC failing into a shorted load, its failsafe fuse, rated at $1\frac{1}{4}$ amps would only allow about 30 amps through before clearing and maintaining the fault current below the main SSPC "must trip" current-time curve. Care must be used in selecting the SSPC's used for cascading. The fail-safe fuse rating and SSPC current rating must be small enough compared to the main SSPC so that no failure other than an AC input to ground short will cause the main SSPC to trip.

2.21.9 REPETITIVE PULSED LOADS

Pulsed loads are compatible with the proposed time-trip and status circuits provided that the minimum load current does not drop below 10% of rated current and the maximum load current does not exceed 1000% of rated load current. During pulsed overloads and since the

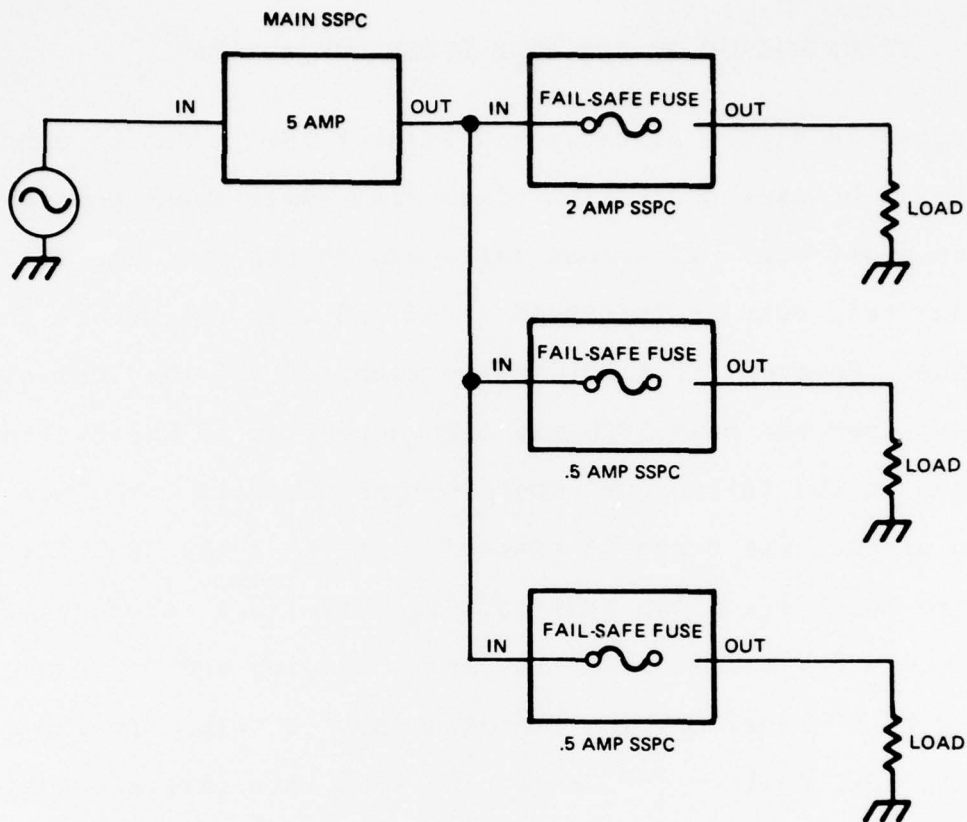

1795

Figure 33. Cascading SSCP's for Protection of Several Small Loads

time-trip circuit senses the peak load current, the timing capacitor will continue to charge during each pulsed overload. The SSCP would eventually trip out for pulsed overloads, provided the duty cycle of these overloads is compatible with the time constant determined by the timing capacitor's "controlled leakage" circuit. The "controlled leakage" circuit" reduces the accumulation of time when sufficient overloads do not exist.

SECTION III

PROPOSED DESIGN AND SYSTEM CONFIGURATION

After consideration of the many factors affecting each segment of the SSPC design, the main design approach recommended is for a 5 AMP, 115V, 400 Hz SSPC. The design will be completely reviewed and reevaluated during Phase II.

Transistors are selected as the pass elements because of their superior load compatibility, no dv/dt problems, ease of fuse selection, and simple base drive configuration. The proposed transistor pass section has been breadboarded and extensively tested at Telephonics during Phase I of this program. The use of power MVOS VMOS transistors as drivers will require almost no current from the power supply, reducing the size of the filter capacitors and transformer.

The control input/output is the two-wire system, with TRIP and STATUS sent as impedance changes over the control lines. The use of the 2 wire interface results in a saving of 50% in wiring harness weight compared to a 6 wire system. The cost differential between the two interfaces is analyzed in the LTV final report. This difference amounts to 67.338 million dollars over the life of the aircrafts. The SSPC circuit complexity is also reduced by using the 2 wire I/O interface. A mono-chip used for the 2 wire I/O interface has been designed and tested. This mono-chip could be used as the proposed interface I/O circuit with little or no changes.

The internal power supply will be a transformer, full-wave and capacitor filter with a switching regulator.

The Status Monitor monitors the output current and transmits a fault when the load current drops below 10% to 15% of rated current. The Output Shunt contains an active Shunt switch, which reduces power dissipation in the ON state.

The current sensor is a single resistor which provides identical response for full-wave and half-wave loads.

The Time Trip circuit is an analog implementation controlled by a resistor and capacitor timing circuit.

Remote programmable trip current levels are desirable to reduce the number of different SSPC current ratings required in the LMC. However, there are serious circuit problems that must be considered.

The optimum voltage drop across the current sensing resistor is determined to be 100 mv at rated load current. A SSPC programmable from 1 to 10 amps would require the current sense amplifier to operate with inputs from 1 mv (10% of rated load current for fault indication at 1 amp level) to .1 volt (1000% of rated load current at instant trip). If however, the load voltage is used to indicate status, then the current sense voltage range is 10 mv to .1 volt. The power dissipation will vary as the square of the current or in this example 100 times.

An alternate approach to programming the current rating is to maintain a fixed voltage drop across the current sense resistor and vary the sense resistor. This would mean that two additional pins must be brought out to pick up the external current sense resistor

in a canned unit. On a printed circuit card SSPC with multiple controllers, this could easily be accomplished by soldering in the appropriate resistor or jumper wire. The load distribution analysis as delineated in the Douglas and Vought Reports shows that most loads can be serviced by 1 amp, 5 amp, and 10 amp SSPC controllers. It is possible then, on a Quad SSPC printed circuit card, for the factory to program the rating of each SSPC for different load current ratings.

The ZVTO and ZCTO functions are implemented by turning the pass transistors on and off during their normally non-conducting half-cycles, thereby eliminating the need for a precise zero-crossing circuitry.

The same ZVTO and ZCTO circuit can be used for controlling a SCR pass section making the monochip arrays universal in application.

The optical couplers will be fabricated using a technique recently developed by a hybrid manufacturer working together with Telephonics. The technique involves mounting an LED chip and a PIN diode chip on a hybrid substrate which are then optically coupled through a passivation layer. This optical coupler will combine small size, nuclear resistance, high dielectric withstanding voltage, and good electrical characteristics in a small package designed for production on a hybrid substrate.

Optical couplers are selected over transformer-coupled oscillators for cost, simplicity, size and weight advantages.

The optical couplers used on the B-1 Flight Evaluation units successfully passed B-1 level nuclear susceptibility requirements, by

a factor of 10. The key to the design was found to be the use of a PIN diode as the receiving element.

3.1 ALTERNATE SSPC SYSTEM CONFIGURATIONS

In addition to the SSPC configuration, Telephonics also recommends the following two SSPC configurations for design, fabrication and evaluation in phase II of this study program.

- a. The DC SSPC described in Section II, paragraph 2.16 and shown in figure 16 is recommended. This configuration is a 5 amp SSPC with 100% instant trip characteristics. Approximately 58% of the total quantity of controllers required on the C-15 Military Air Transport and A-7A size aircrafts are DC power controllers.
- b. The 3 phase 4 wire SSPC configuration shown in figure 25 is recommended. It consists of multiple single phase SSPC's sequenced on and off at the proper time for ZVTO and ZCTO. The proposed ratings are 5 AMPS RMS, 115 VAC, 400 Hz 3 ϕ . Approximately 16% of the total controllers required are 3 ϕ power controllers.

3.2 SOLID STATE POWER CONTROLLER MODULE CONSTRUCTION CONSIDERATIONS

A conceptual design for a modular approach for packaging many SSPC's in a given location has been explored. A reasonable design arrangement in consideration of thermal heat concentration, structural rigidity, and general handling capability, is to package a

maximum of four SSPC's on a single printed wiring board module. The modules could then be assembled in an enclosure capable of supporting several modules. By this integration process, a variety of aircraft applications can be satisfied.

The printed circuit board (PCB) module will be constructed using high quality FLGH glass base, epoxy resin plastic per MIL-P-13949. This material is flame retardant, heat resistant and can withstand operating temperatures up to 150°C. The PCB etched copper conductors and space between conductors will be in accordance with MIL-STD-275. Typically, conductor thicknesses are approximately 0.003 inch with minimum spacing of 0.030 inch. Conductor widths will be selected according to current rating requirements for minimum local temperature rises. Wave soldering techniques can be used to reduce assembly costs and minimize the PCB module size.

Quality assurance of the PCB construction will be to MIL-P-55110. After assembly, the PCB and components will be conformal coated per MIL-I-46058 to provide insulation protection from moisture environments. The coating additionally provides good damping characteristics for component leads and wires to protect against disturbing aircraft shock and vibration.

An optimum PCB module size having four SSPC segments is approximately 7.5 inches wide by 6.8 inches high. The PCB thickness will be 0.062 inch, except at its leading edges where laminated aluminum overlays of approximately 0.040 to 0.060 inch thickness and 1-1/4 inch wide will be incorporated. High power transistor banks and heavy transformer elements will be mounted directly to

these overlays. The purpose is to enable good thermal conductive paths to outside contact surfaces and to provide additional support for heavier component elements.

The SSPC module will be a quick disconnect, plug-in arrangement with a connector affixed to the bottom edge and a handle at the top. The printed circuit connector will be a plug-receptacle type, with mechanical float and fabricated to MIL-C-55302. The handle at the upper edge will facilitate insertion and withdrawal of the module. The handle will be light weight, high strength aluminum, 6061-T6 alloy material, riveted to the PCP and configured to an angle section. The handle design is intended to provide structural support for the PCB as well.

3.3 WEIGHT CONSIDERATIONS

The individual can type of SSPC weights approximately four ounces. The PCB module having four SSPC segments is estimated to weigh about 11-12 ounces, and a load center assembly with 16 PCB modules providing 65 power controllers, is anticipated to weight between 28 lbs. to 30 lbs.

3.4 STRUCTURAL DYNAMICS

The vibration environments typical to these aircraft are both steady state and random excitation. Random vibration test levels of severe magnitude vary in power spectral density up to a maximum of $.83 \text{ G}^2/\text{HZ}$ in a frequency band width of 20 - 2000HZ. Steady-state vibration is generally severest at 15g-input acceleration levels in frequency limits of 5 - 2000 HZ. The steady-state vibration test normally requires an endurance phase where the equipment must be vibrated

to its mutual frequencies for a given period of time. This procedure is generally most damaging to electronic equipment and requires special consideration to the fatigue characteristics of design materials.

Since it is often difficult to design aircraft electronic equipment beyond the upper test band frequency with minimum weight guidelines, the design objective for the SSPC PCB module is to establish a weight to stiffness ratio such that the lowest order elastic bending frequency is as high as possible in the frequency test band and the associated stress leads are below the material endurance limit. This is accomplished by locating the heaviest components, such as the power transformer, close to the load supporting edges. Other components are arranged to uniformly distribute their load over the entire board surface area. The card guides previously described are instrumental in maintaining good support of the PCB edges by virtue of their high contact pressure. The handle at the board top surface also serves as a stiffener to improve the PCB structural rigidity.

3.5 SOLID STATE POWER CONTROLLER LOAD CENTER

The LMC specified for the C-15 aircraft in the Douglas Interim Report suggests that both SSPC's and E-MUX compatible RCCB's be contained in the same LMC. The SSPC assembly would consist of a Quad-SSPC printed circuit card with a common power supply with redundancy capabilities. These LMC (panel boards) would be located at the appropriate load center on the aircraft much as the instrument station, cockpit, FWD cargo, etc. Separate LMC's are required for AC and DC SSPC's.

LTV emphasis for the A7-D aircraft has been on canned SSPC's rather than printed circuit cards, mounted on .125 inch thick aluminum plates contained in the load management center. Each LMC assembly is hinged for easy access to power controllers and other components mounted in the center. The number of SSPC's per LMC varies depending on its location in the aircraft. The left avionics by LMC could have 132 controllers including spares, while the wing LMC could have as few as 12 SSPC's including spares. Six main LMC's are required along with a special LMC for 26 VAC instrument power.

A conceptual design for the SSPC load center from a mechanical viewpoint is depicted in Figure 34. The load center concept provides a modular assembly of SSPC printed wire boards in a tandem stacked arrangement. A reasonable size for the load center is 9 inches wide by 7.5 inches high by 17.5 inches deep. The load center will be capable of installing up to sixteen SSPC modules for a total of 64 individual SSPC's. Dependent upon the requirements for each aircraft in this program, the load center can be optimized further.

The load center design will be of light weight aluminum material construction. The side walls will be approximately 5/8 inch wide cold plates having .0060 to .008 inch thick fins with about 14-18 fins per linear vertical inch. The PCB modules will access from the top and attach via card guides directly to vertical ribs located on the side walls. From a plenum area located at the rear of the load center, conditioned aircraft forced air will inlet and be passed uniformly through the cold plate side walls. The cooling

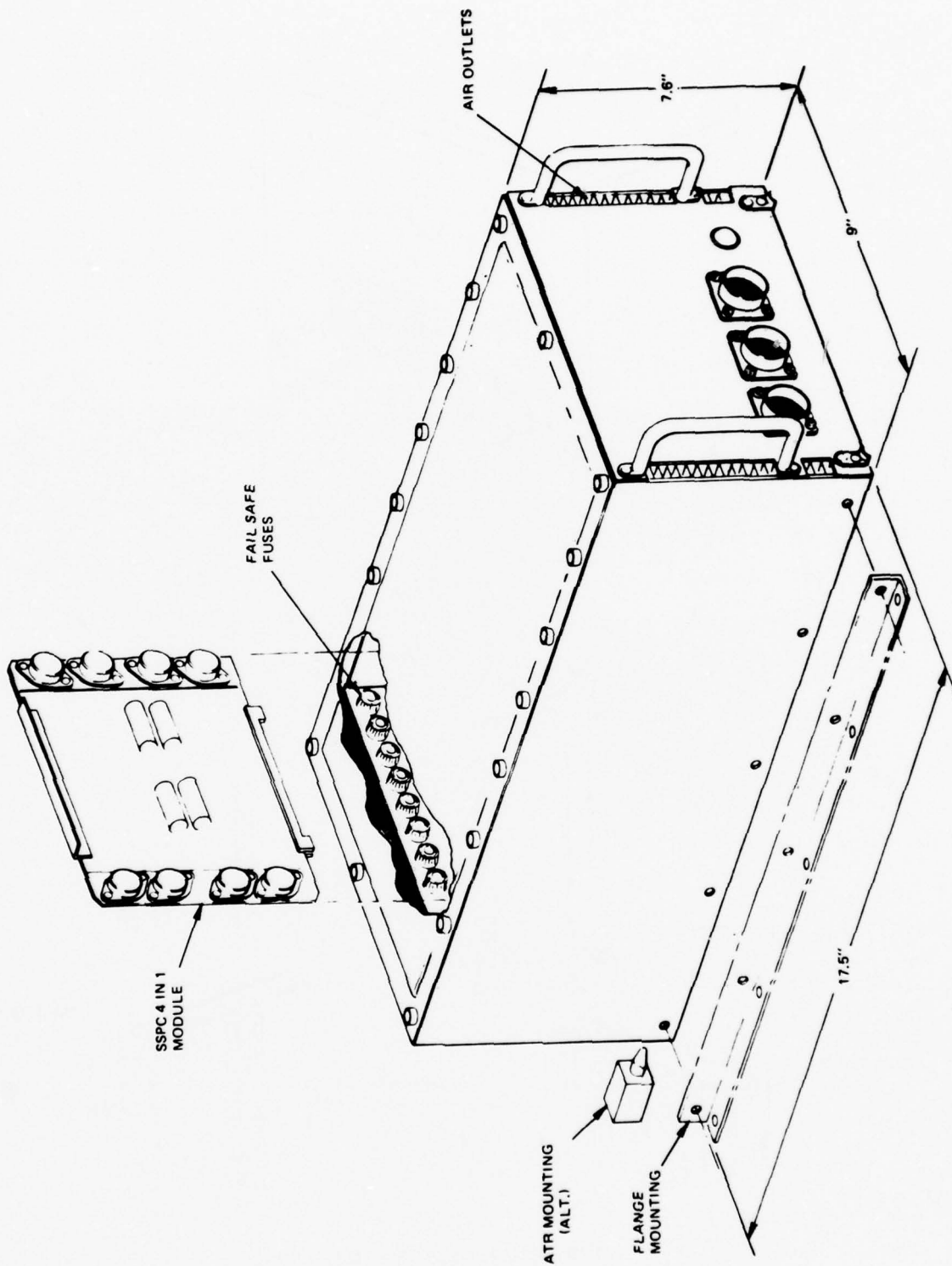
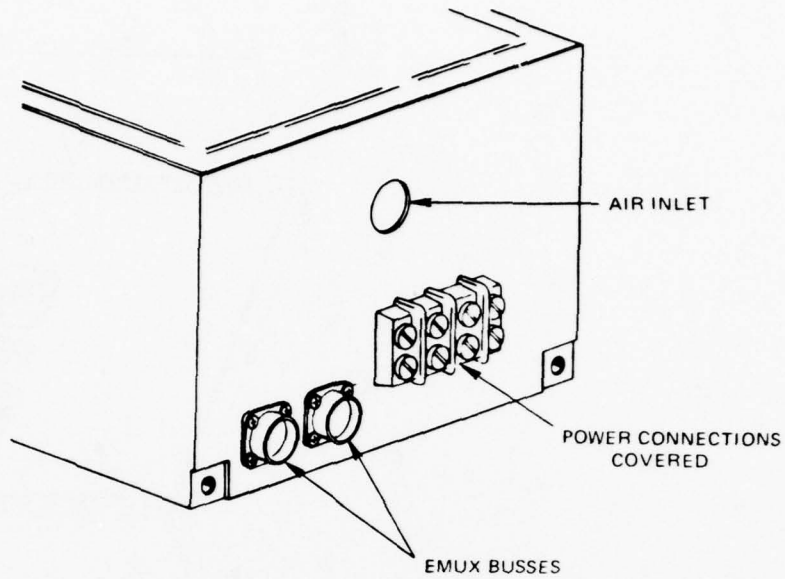
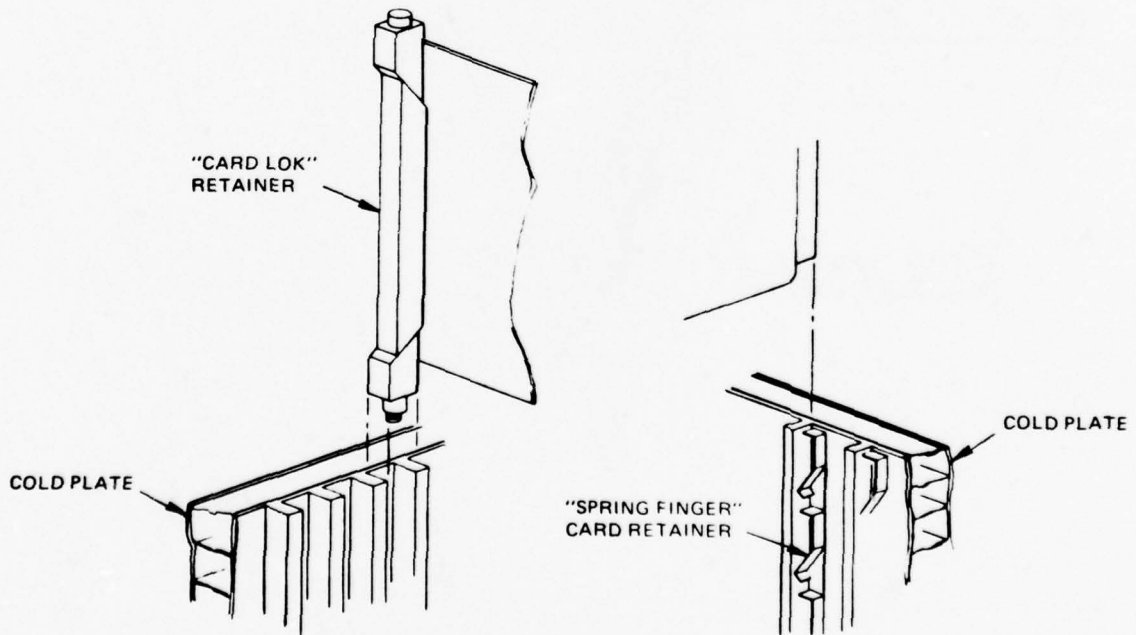

Figure 34. Typical Load Center
(Sheet 1 of 2)



REAR PANEL



CONDUCTIVE COUPLING TO COLD PLATE

Figure 34. Typical Load Center
(Sheet 2 of 2)

1761

air will exhaust at the load center front surface. Screens will be affixed at the outlet openings to prevent small article entrapment in the cold plates. These screens will be 50% to 60% open in order that air pressure head loss is kept to a minimum.

The PCB modules will connect directly to female connector receptacles located on a "motherboard" at the base of the load center. Input power connection will be made at the rear surface of the load center via terminal board contacts. From the terminal boards, the power will be based to fuses (64) mounted to a plate at the rear section and to the motherboard.

The fuses may optionally be placed at the front panel, however, due to additional wire runs required in that approach, placement of the fuses in the rear appears advantageous from a cost and weight consideration. The rear surface will additionally provide two EMUX MS connectors (size 10 shell) and an air inlet fitting.

The front panel of the load center will mount three output connectors (size 22 shell O, two carrying handles, and a power indicating light. The load center top access cover will be structurally formed light weight aluminum alloy 6061-T6 material. The cover will incorporate nylon "keeper" elements with silicone cellular rubber compression pads. This combination will secure the PCB modules and aid in restricting their lateral and vertical motion under dynamic disturbances. Cover attachment to the housing will be via captive fasteners secured in the cover.

Attachment of the load center to the aircraft will be analyzed during the Phase II interface study. Optional attachment concepts may be either a flange type mounting arrangement at the load center lower side surfaces or a classical ATR type rear pin-front lock spin wheel combination.

3.6 THERMAL CONSIDERATIONS

The basic load center is cooled with aircraft supplied ECS (Environmental Control System) conditioned air. The chassis walls contain plate-fin type cold plates that limit the card bay wall temperature to acceptable levels. PC board temperature gradients are limited by use of aluminum or copper heat sink overlays that conduct the heat to the card edge. Card edge wedge locks couple the PC board heat to the card bay wall that is integral to the cold plate chassis.

The controlling thermal resistances from component case to inlet delivery air are as follows:

- a. Cold plate thermal resistance
- b. Wedge lock resistance
- c. PC board heat sink resistance

A sample calculation, see appendix, for a system dissipation of 800 watts with 16 PC cards each dissipating 1.0 watts/in² of board area (50 watts; card size 7.5" x 6.5"). The assumed aircraft interface is as follows:

Maximum operating ambient, 71°C

Available air flow at 90° inlet air...3,39 lb. min. kw

Allowable system pressure drop...2.0 inches H₂O

At the 1.0 watt/in² power density level, a typical thermal design includes the following features:

50 watts/PC Board...16 PC Boards

System power dissipation...800 watts

Card size 7.5" x 6.5"

Aluminum heat sink overlays at both card edges; 0.0625" thick

6" long wedge lock "clips" used at card edges (thermal resistance, 0.4°C/w

In type and geometry.....0.413" high, 0.006" thick, plain fin 18 fins/inch, 0.1" thick end sheet on inside wall (.05" on outside wall)

The thermal profiles resulting from this typical design are as follows:

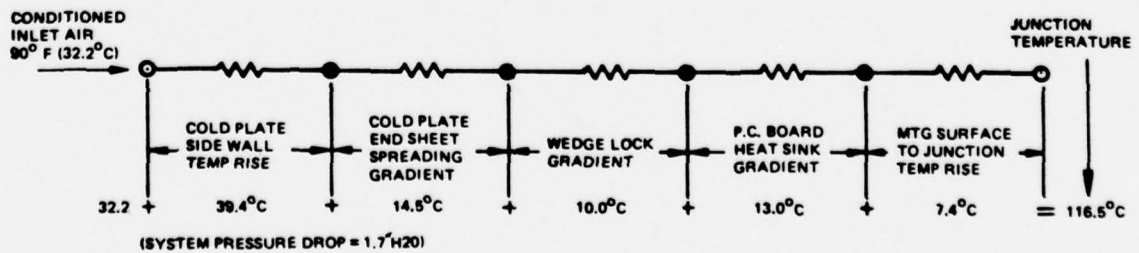

The aforementioned analysis results show that at the 1.0 watt/in² power density level, the junction temperature can be limited to less than 125°C.

However, in order to increase power density levels above 1 watt/in², evaluation studies (including testing) must be made for various wedge lock configurations since this thermal resistance will become the controlling impedance path.

APPENDIX A

Copy number

Report number

ADVANCED SOLID STATE

POWER CONTROLLER DEVELOPMENT

PHASE I REPORT

(USAF CONTRACT F33615-77-C-2017)

Revision date

Revision letter

Issue date April 12, 1978

Contract number P.O. 62878

Prepared by

W. E. Murray

W. E. Murray, Senior Engineer/Scientist
Electrical Power System Design

Approved by

J. V. Creager, Section Chief
Electrical Power System Design

Approved by

D. H. Blyther

D. H. Blyther, Branch Chief
Electrical Technologies and Research

FOREWORD

The studies described in this report were performed by Douglas Aircraft Company, a division of the McDonnell Douglas Corporation under subcontract to Telephonics Division of Instrument Systems Corporation. This effort is in support of work being conducted by Telephonics for the Air Force Aero Propulsion Laboratory (AFAPL/POP) at Wright-Patterson Air Force Base, Dayton, Ohio under Contract F33615-77-C-2017.

This report covers the Phase I effort only and will be supplemented or revised at a later date to report on the Phase II effort.

ACKNOWLEDGEMENT

This report summarizes work performed during the period October 1, 1977 through April 1, 1978. The effort was authorized under Telephonics Purchase Order No. 62878. Material reported herein resulted from the efforts of Mr. W. E. Murray of Electrical Engineering with significant contributions from Mr. D. W. Rowell of Avionics Engineering and Mr. J. E. Knaul of Electrical Engineering.

This report has been reviewed and is approved.

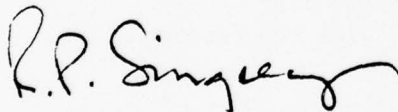

R. P. Singelyn, IRAD/CRAD Coordinator
Electrical Engineering

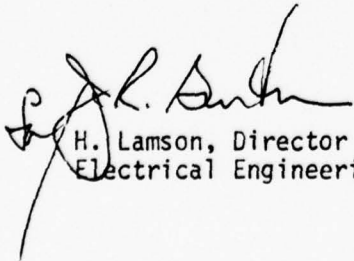

H. Lamson, Director
Electrical Engineering

TABLE OF CONTENTS

SECTION		PAGE
I	INTRODUCTION	120
	1.1 SCOPE OF STUDY	120
	1.2 KEY TECHNICAL STUDY REQUIREMENTS	122
	1.2.1 Military Transport Model	122
	1.2.2 Electrical Power System Model	124
II	TECHNICAL DISCUSSION	129
	2.1 KEY ISSUES	129
	2.1.1 Electrical Power System Integrity	129
	2.1.2 Electrical Power System Interface Compatibility	134
	2.1.3 Electrical Power System Cost	136
	2.1.4 System Safety	137
	2.1.5 Tolerance To Operational Aircraft Environments	137
	2.1.6 Impacts On Aircraft Electrical Power System Design	137
	2.1.7 Flexibility for Application to Diverse Electrical Circuits and Loads	138
	2.2 MILITARY TRANSPORT ELECTRICAL SYSTEM REQUIREMENTS	139
	2.2.1 Electrical Power System Requirements	139
	2.2.2 Electrical Power Distribution Subsystem Requirements	141
	2.2.3 General Requirements For SSPC Design and Electrical Power Subsystem Interfaces	142
	2.2.4 Detailed Requirements for SSPC Design and Electrical Power Subsystem Interfaces	143
	2.3 ELECTRICAL LOAD AND PANEL ANALYSIS	150
	2.3.1 Electrical Load Analysis	150
	2.3.2 Electrical Panel and Feeder Analysis	150
	2.3.3 Electrical Panel Design Features	153
	2.4 ELECTRICAL SYSTEM FAULT CURRENT ANALYSIS	156
	2.4.1 Generator Characteristics	156
	2.4.2 Generator Internal Voltage (E_f)	157
	2.4.3 Conductor Impedances for C-15 Aircraft Model	157
	2.4.4 C-15 Model Generator Feeder Impedances	158
	2.4.5 Three-Phase Fault at EPC with 100% Pre-Load	159
	2.4.6 Three-Phase Fault at EPC with no Pre-Load	165
	2.4.7 Single-Phase Fault at EPC with 100% Pre-Load	166

SECTION		PAGE
II	2.4.8 Fault Current Calculations Summary	168
	2.4.9 Panel Board Fault Currents	172
	2.4.10 Current Rate-of-Change di/dt	180
	2.4.11 Aircraft Load Branch Circuit Characteristics	182
	2.5 E-MUX SYSTEM	183
	2.5.1 E-MUX Digital Computers	183
	2.5.2 Digital Transmission Line	185
	2.5.3 Multiplex Terminal Units	186
	2.5.4 Solid State Power Controllers	188
	2.5.5 E-MUX Control/Display Center	190
APPENDIX A	DETAILED ELECTRICAL LOAD LISTS	194
APPENDIX B	DETAILED LOAD LOCATION LISTS	232
APPENDIX C	AC SYSTEM PANEL AND LOAD SUMMARY	242
APPENDIX D	DC SYSTEM PANEL AND LOAD SUMMARY	253

LIST OF ILLUSTRATIONS

FIGURE		PAGE
1-1	C-15 Military Air Transport Aircraft	123
1-2	Electrical Power System Model Schematic	125
1-3	Electrical Power Load Profile (Histogram)	127
2-1	C-15 Military Air Transport Profiles	130
2-2	In-Board Profile of C-15 Military Air Transport Aircraft	131
2-3	Electrical Power System Protective Device Coordination	133
2-4	Panel Board Location Plan	152
2-5	E-MUX-Controlled SSPC/RCCB Panel Board - Single	154
2-6	E-MUX-Controlled SSPC/RCCB Panel Boards - Multiple, Co-Located Panels	155
2-7	Fault Current Characteristics, RMS Values	164
2-8	Electrical Power Center Fault Current Characteristics	171
2-9	Panel Board X Fault Current Characteristics	179
2-10	Fault Current Envelope For Electrical Power Center	181
2-11	Proposed E-MUX Concept	184
2-12	Typical Multiplex Terminal Unit (MTU)	189
2-13	Typical Aircraft System Display Panel (DC-10 Electric Panel)	192
2-14	Integrated Electric Power Display Panel	193

LIST OF TABLES

TABLE		PAGE
1-1	TASK DESCRIPTIONS-PHASE I	121
1-2	KEY TECHNICAL FEATURES	123
2-1	KEY ISSUES	129
2-2	THREE-PHASE FAULT CURRENTS AT EPC	169
2-3	SINGLE-PHASE FAULT CURRENTS AT EPC	170
2-4	THREE-PHASE FAULT CURRENTS	175
2-5	SINGLE-PHASE FAULT CURRENTS AT SSPC/RCCB PANELS	178
2-6	E-MUX TERMINAL (MTU) ASSIGNMENTS SSPC/RCCB PANEL BOARD LOCATION	187
A-1	115 VAC SYSTEM - BUS 1	196
A-2	115 VAC SYSTEM - BUS 2	199
A-3	115 VAC SYSTEM - BUS 3	202
A-4	115 VAC SYSTEM - BUS 4	205
A-5	115 VAC - EMERGENCY BUS	208
A-6	28 VDC SYSTEM - BUS 1	211
A-7	28 VDC SYSTEM - BUS 2	215
A-8	28 VDC SYSTEM - BUS 3	218
A-9	28 VDC SYSTEM - BUS 4	222
A-10	28 VDC SYSTEM - EMERGENCY BUS	226
A-11	28 VDC SYSTEM - BATTERY BUS	228
A-12	28 VDC SYSTEM - BATTERY DIRECT BUS	231
B-1	AC LOAD LOCATIONS	233
B-2	DC LOAD LOCATIONS	237
C-1	AC SYSTEM PANEL AND LOAD SUMMARY - AC SYSTEM - BUS 1	244
C-2	AC SYSTEM PANEL AND LOAD SUMMARY - AC SYSTEM - BUS 2	246
C-3	AC SYSTEM PANEL AND LOAD SUMMARY - AC SYSTEM - BUS 3	248
C-4	AC SYSTEM PANEL AND LOAD SUMMARY - AC SYSTEM - BUS 4	250

TABLE		PAGE
C-5	AC SYSTEM PANEL AND LOAD SUMMARY - AC SYSTEM - EMERGENCY BUS	252
D-1	DC SYSTEM PANEL AND LOAD SUMMARY - DC SYSTEM - BUS 1	254
D-2	DC SYSTEM PANEL AND LOAD SUMMARY - DC SYSTEM - BUS 2	256
D-3	DC SYSTEM PANEL AND LOAD SUMMARY - DC SYSTEM - BUS 3	258
D-4	DC SYSTEM PANEL AND LOAD SUMMARY - DC SYSTEM - BUS 4	260
D-5	DC SYSTEM PANEL AND LOAD SUMMARY - DC SYSTEM - EMERGENCY BUS	262
D-6	DC SYSTEM PANEL AND LOAD SUMMARY - DC SYSTEM - BATTERY BUS	263
D-7	DC SYSTEM PANEL AND LOAD SUMMARY - DC SYSTEM - BATTERY DIRECT BUS	265

SECTION I INTRODUCTION

1.1 SCOPE OF STUDY

This interim report covers Phase I of the Douglas Aircraft Company studies, under subcontract to Telephonics, a Division of Instrument Systems Corporation, in support of USAF Contract F33615-77-C-2017.

The work conducted in Phase I under this subcontract consisted of preliminary studies to achieve successful and cost-effective integration of solid-state power controllers (SSPCs) into a large military transport aircraft.

The scope of this Phase I effort is shown in Table 1-1, Phase I Task Descriptions, derived from the proposed study approach. The preliminary study effort consisted of the following tasks:

- (1) The identification of key issues and design/integration/safety requirements.
- (2) The definition of a model electrical power system for a large military transport aircraft, based on the C-15 preliminary design, with its load and distribution system.
- (3) The synthesis of conventional and electrical multiplex (E-MUX)-driven distribution system configurations, with locations of panelboards based upon the location of loads.
- (4) The analysis of normal steady-state and transient fault currents, of both three-phase and single-phase types, within the C-15 model power systems.
- (5) The definition of a prototype aircraft E-MUX system for adaptation to the candidate SSPC system concepts.

The work in Tasks (1) through (5) provided background and trade study data for assistance to Telephonics in optimizing the candidate SSPC/E-MUX systems and the design options with respect to aircraft-related design factors. These trade studies were concentrated on the factors of cost, weight, volume, hardware design complexity, environmental tolerance, reliability, maintainability, and on the design flexibility of these concepts for aircraft application.

The power feeders were characterized for the fault analyses in Task (4) by their routing, lengths, and impedances (both resistances and reactances).

TABLE 1.1 TASK DESCRIPTIONS - PHASE I

<p>1.0 Identify:</p> <ul style="list-style-type: none"> o Design Requirements o Key Issues o Problem Areas <p>2.0 Identify:</p> <ul style="list-style-type: none"> o Design Criteria o Safety Criteria <p>3.0 Identify:</p> <ul style="list-style-type: none"> o Design Requirements for Aircraft Applications of Candidate SSPC Designs and E-MUX Systems <p>4.0 Define:</p> <ul style="list-style-type: none"> o Military Transport Aircraft Model Based on the C-15 Aircraft o Electrical Power System Model o Electrical Load Locations and Characteristics o Electrical Wire Design Characteristics o SSPC Type, Locations, and Ratings <p>5.0 Establish:</p> <ul style="list-style-type: none"> o Power-Center Models and Locations o Load Distribution Center Models and Locations o SSPC Types, Locations, and Ratings 	<p>6.0 Define:</p> <ul style="list-style-type: none"> o E-MUX System Concept for Each SSPC System Design o Terminal (MTU) Locations and Interfaces o Control Processor (CPO) Locations and Characteristics o Data Bus Types and Routing o Aircraft Interfaces <p>7.0 Assist Telephonics Corporation In:</p> <ul style="list-style-type: none"> o Optimizing SSPC Designs o E-MUX Interface Designs o Trade Studies of Design Options o Recommending Component and System Design Options for Air Force Selection <p>8.0 Define:</p> <ul style="list-style-type: none"> o Electrical Power Bus Equivalent Circuits <p>9.0 Provide:</p> <ul style="list-style-type: none"> o Cost Information (As Available) <p>10.0 Prepare:</p> <ul style="list-style-type: none"> o Interim Report - Phase I
--	--

Both three-phase and single-phase faults were analyzed to determine the current magnitudes and phase angles available at the electrical power center and at representative load locations. The fault analyses included consideration of generator saliency, pre-fault load and excitation, remote point-of-regulation at the electrical power center, and feeder impedance effects upon voltages, currents, and time constants.

The electrical loads of the C-15 aircraft model developed in Taks (2) and (3) were categorized by magnitude, type, power factor, and degree of essentiality. The load protection requirements were identified by current levels (1.6A, 2A, 3A, 5A, 7.5A and 10A) and protective devices, SSPC or RCCB (Remote Control Circuit Breaker), panelboards at appropriate locations.

Fault evaluations determined the current levels and decay time constants expected to occur at key panelboards. Motor contributions to fault currents were included where appropriate. These fault currents define the maximum current tripping duty imposed upon the SSPCs.

1.2 KEY TECHNICAL STUDY REQUIREMENTS

The Douglas study was related to an aircraft electrical power system model for a large military transport, the C-15 aircraft. This model was defined as a reference baseline for the trade study evaluations and for future comparisons of the candidate SSPC designs. The key technical features provided by this model are listed in Table 1-2. This aircraft model is shown in Figure 1-1 and described in Section II. As an adjunct to the aircraft model, the key features of a crew-compatible E-MUX control system were defined as a reference baseline for the related trade studies.

TABLE 1-2
KEY TECHNICAL FEATURES

- Realistic Military Transport Aircraft Model Configuration
- Actual Operational Aircraft Loads
- High Short-Circuit-Capability of the Source Power System
- Aircraft Design Criteria
 - Redundancy Consistent with Load Criticality
 - Fail Operational/Fail Safe and "Graceful Degradation"
 - Design Philosophy
- Distribution Circuit Simulation Based on C-15 Aircraft
- E-MUX Control System Concept Compatible with Military Transport and Crew Operational Interfaces

1.2.1 Military Transport Model

The military transport aircraft model was based upon the preliminary C-15 design. This design has four main propulsion engines, a significant level of hydraulic power, large internal volume and a relatively long distance from the cockpit to the tail control surfaces. The electrical power is obtained from generators driven by the wing-mounted engines and from an identical generator driven by the Auxiliary Power Unit (APU) located in the tail region.

This power is received and controlled in two electrical power centers located near the cockpit/cargo bay bulkhead. These power centers are separated physically and functionally to reduce vulnerability to military operational damage. Power feeders from two main generators and an APU power tie-bus are common to each EPC.

The C-15 has a two-person crew and all systems are designed to minimize crew workload with respect to displays, controls, and system monitoring/management activities.

1.2.2 Electrical Power System Model

The electrical power system model is represented by the preliminary electrical power system configuration of the Douglas C-15 military transport. This configuration, shown in Figure 1-2, consists of four similar "channels", each having a 40 KVA generator source deriving its prime power through a hydromechanical constant speed drive (CSD) from a main propulsion engine. Each generator has an independent excitation and control subsystem and an associated generator bus located at one electrical power center (EPC). The generator buses, operating in either isolated or paralleled modes, supply alternating current (ac) power to ac panelboard load buses at appropriate locations in the aircraft. An auxiliary power system (APU) uses a 40 KVA generator, interchangeable with the main engine generators. APU power is available to either the left or right EPC through a tie bus and auxiliary power relays. On the ground, external power is available to either the left or right EPC through the tie bus and external power relays. The APU is not designed for parallel operation with the main generators. The APU is used primarily for ground power at remote air-fields, and can also be used for back-up power in flight in the event of loss of main generator power to one or both EPCs. One transformer-rectifier is supplied with power by each generator bus, creating direct current (dc) power which is distributed by dc feeders to appropriately located dc load buses.

Bus-tie power relays permit the generator buses to be operated in isolated, split-parallel (with the two left and the two right buses parallel separately), or fully paralleled configurations. Normal operation is in the split-parallel configuration, which is used as the baseline for this study. This configura-

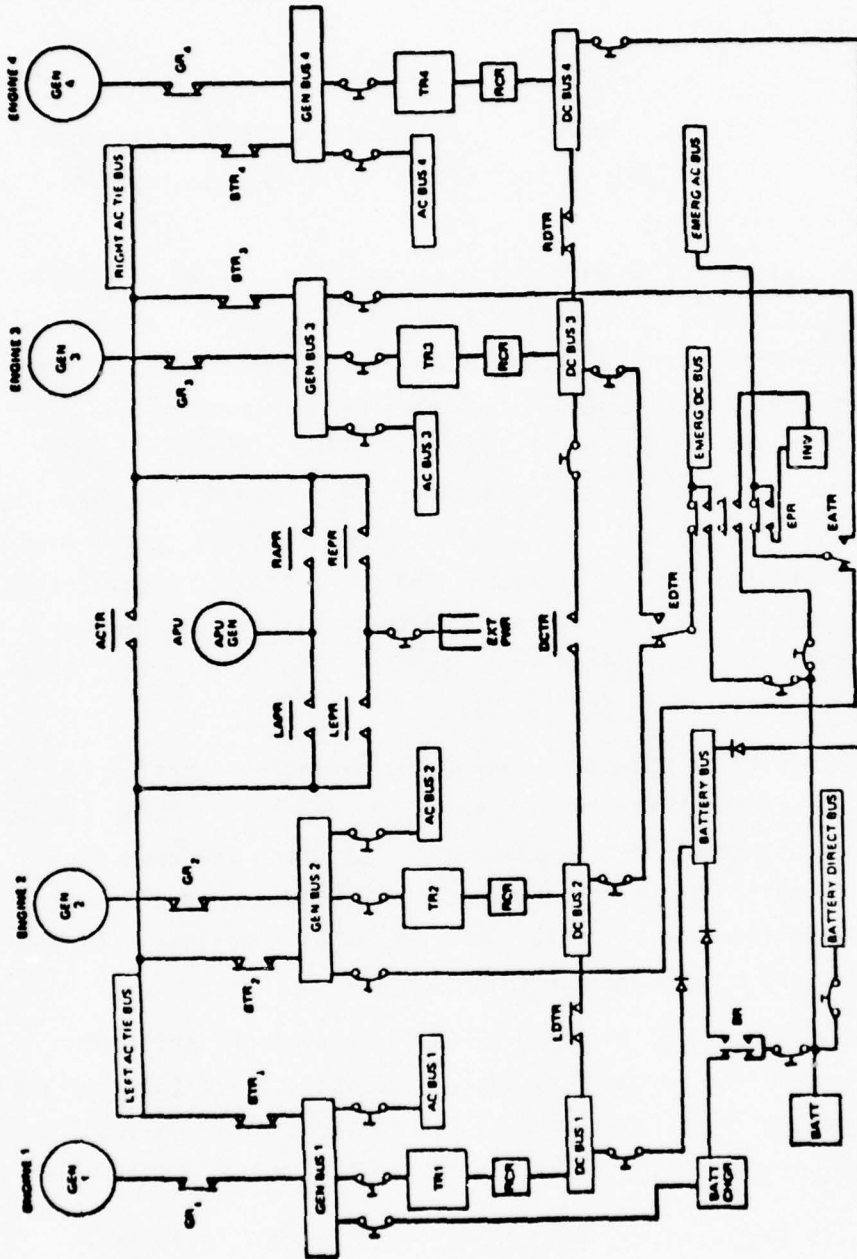

- ACTR — AC CROSS-TIE RELAY
- APU — AUXILIARY POWER UNIT
- BATT CHGR — BATTERY CHARGER
- BR — BATTERY RELAY
- BTR — BUS TIE RELAY
- DCTR — DC CROSS-TIE RELAY
- EATR — EMERGENCY AC TRANSFER RELAY
- EDTR — EMERGENCY DC TRANSFER RELAY
- EPR — EMERGENCY POWER RELAY
- EXT PWR — EXTERNAL POWER
- GEN — GENERATOR RELAY
- GR — GENERATOR RELAY
- INV — INVERTER
- LAPR — LEFT AUXILIARY POWER RELAY
- LOTR — LEFT DC TIE RELAY
- LEPR — LEFT EXTERNAL POWER RELAY
- RAPR — RIGHT AUXILIARY POWER RELAY
- ROCR — RIGHT EXTERNAL POWER RELAY
- RDTR — RIGHT DC TIE RELAY
- REPR — RIGHT EXTERNAL POWER RELAY
- T-R — TRANSFORMER-RECTIFIER

Figure 1-2. Electrical Power System Mode 1 Schematic

tion makes 80 KVA available to each EPC, but also reduces fault-current duty of the EPS and reduces vulnerability to battle damage when compared with a fully paralleled configuration.

Multiple power sources to the EPC and multiple feeders from the EPC provide significant gains of reliability. The electrical load profile or histogram, Figure 1-3, shows that the power from either EPC is sufficient to sustain all normal aircraft operations.

The preliminary load analysis is provided in Section II, as is the operational load profile. Such data defines the total load (ac and dc), and also defines the short-term and long-term demand load power levels. The latter is estimated to be 34.5 KVA for aircraft-peculiar loads. The mission-peculiar loads add as much as 25.5 KVA more, giving a total initial power level of 60 KVA. The source capacity of 120 KVA, with one main generator incapacitated, provides the required 100% margin for growth. These loads were located by coordinates in the aircraft model during this study, along with their related distribution load-center (panelboard) locations. The feeder wire-sizes, circuit-breaker current limits, and trip-current ratings were also modelled as a part of this study. These data are described in Section II.

SSPC control power integrity is essential during any credible ac system fault, signal source power is necessary for monitoring of the electrical power status, and signal source power is required for other discrettes which are used for E-MUX control logic stimuli. These requirements dictate that control power source redundancy be provided for essential SSPC and E-MUX functions. Three control power options were considered for this study.

- (a) Hybrid EMUX/ICU control, in which SSPCs for non-flight critical loads are controlled by the EMUX system and SSPCs for flight-critical loads are controlled by small manual CBs in the cockpit called ICUs (Indicating Control Units). This is the initially preferred option.
- (b) Dual or Split EMUX Control, in which a separate EMUX system with control power derived from the emergency ac bus or the battery is provided for flight-critical load SSPCs.

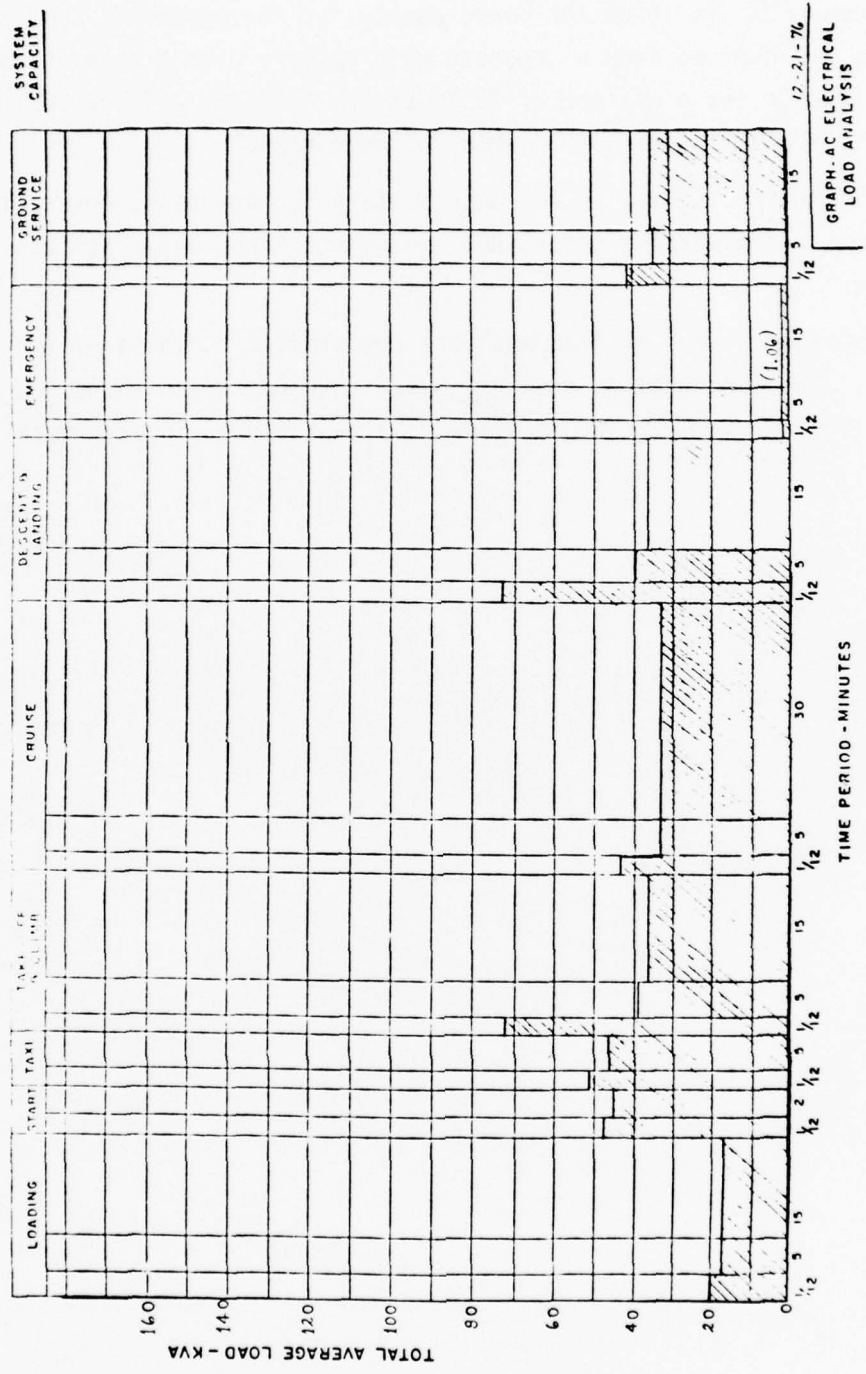

Figure 1-3. Electrical Power Load Profile (Histogram)

- (c) Common EMUX, in which the power supply for the redundant EMUX systems are derived from a separate main battery with a capacity of 2000 watts for a minimum of 20 minutes. A 50 Ahr C-15 or DC-10 battery would provide 40 minutes of operation.

The dc system model includes a 50 Ahr main battery for emergency power, instrumentation, caution and warning power, APU engine-starting, and other essential aircraft loads.

The details provided by the dc load analysis are similar to those of the ac load analysis. The SSPC designs that are based on power transistors and are capable of switching either ac or dc loads will be included in the trade study.

SECTION II TECHNICAL DISCUSSION

This study addressed a series of key issues and system design considerations. From these principles and the C-15 and DC-10 design, detailed criteria and requirements were determined. These are the basis for this study of the comparative merits of a number of SSPC/E-MUX design options. All studies are based on the C-15 military transport aircraft illustrated by Figures 2-1 and 2-2.

2.1 KEY ISSUES

The key issues addressed by this study are listed in Table 2-1.

TABLE 2-1
KEY ISSUES

Electrical Power System Integrity
Electrical Power System Interface Compatibility
Electrical Power System Cost
System Safety
Tolerance to Operational Aircraft Environments
Impact on Aircraft Electrical Power System Design
Flexibility for Application to Diverse Electrical Circuits and
Loads

Even though some of these terms are of relatively common usage and require no further definition, some terms are unique to aircraft, to a particular organization, or even to the needs of a particular trade study. Therefore, all terms will be defined or redefined to create a framework for common understanding.

2.1.1 Electrical Power System Integrity

Electrical power system integrity is defined as that quality of a system that ensures full functional capability of the system after a single failure, although the performance level and margins may be degraded to some acceptable extent (Fail Operational). A power system, to provide the requisite integrity, must allow only a minimal removal of hardware from service; and, as a consequence of a second failure, must fail only in a safe manner (Fail Safe),

THIS PAGE IS BEST QUALITY PRACTICABLE
FROM COPY FURNISHED TO DDC

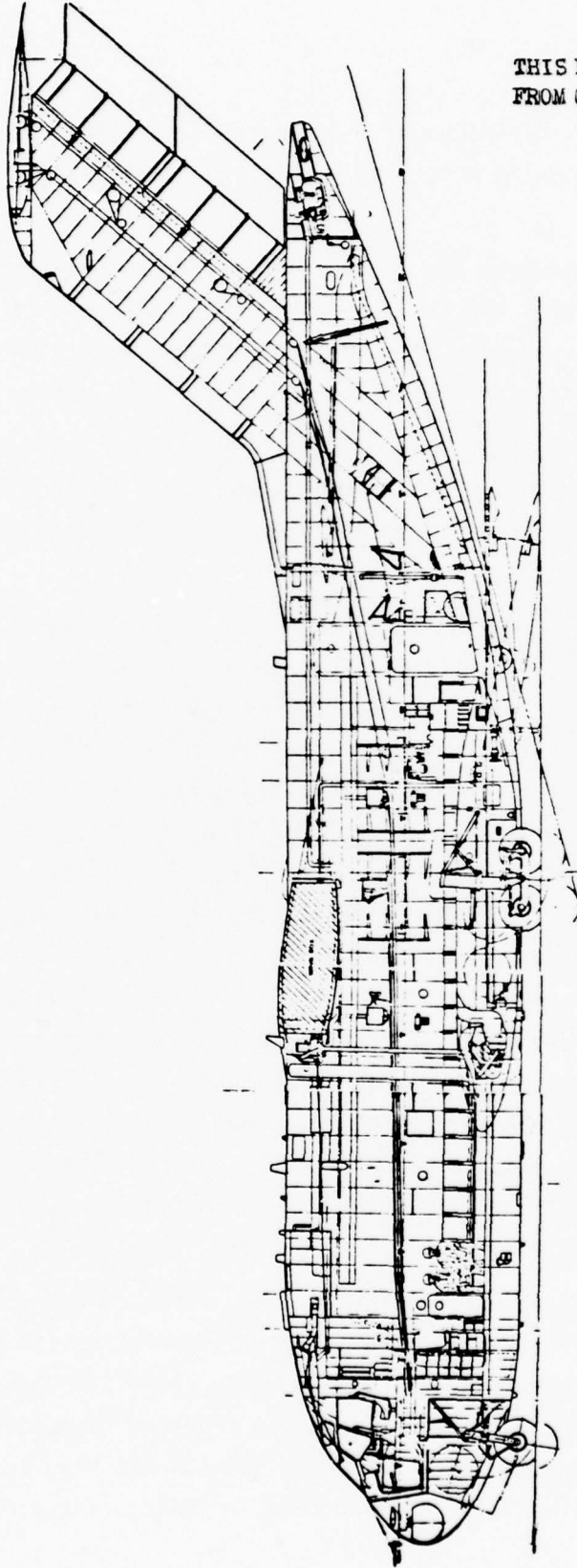

Figure 2-2. In-Board Profile of C-15 Military Air Transport Aircraft

while again removing only a minimum of hardware from service. This concept of system integrity is usually described as "Fail Operational/Fail Safe (FO/FS)".

Power system integrity requires the operational assurance provided by a fully coordinated fault-protection and fault-removal system design. It also requires reliable circuit switching, a safe level of load isolation, and full assurance that false triggering (switching) modes will not occur.

It is clear that the introduction of solid state power controllers to replace conventional thermal-magnetic or electromagnetic circuit-breakers must provide at least equal measures of functional and operational integrity to the electrical power system.

The very rapid tripping capability of the SSPC may be utilized to reduce the probability of damage to loads or circuit wiring on particularly severe overloads or fault currents. It may also be used to assure the proper sequencing of the protective devices in a "cascade" mode, as shown in Figure 2-3. Any protective devices (A) within the load, normally thermal overload protective devices, should trip first to protect the load; then the load circuit protective devices (B) (CB or SSPC) should trip to protect the circuit conductors and to function as "backup" protection for the load protective device. Next in order of time sequence, the system design may provide feeder SSPCs or RCCBs (C) to protect the feeder conductors to the SSPC panelboards. The generator bus power will be distributed by major feeders protected by RCCBs (D) in the present designs or by hybrid power controllers (in future designs) for high-current ratings. For large non-essential loads and feeders, the protective devices may be fuses or limiters (D') to protect the large feeders from major electrical power centers. Load-shedding control for such circuits must be provided by power relays.

Protection from faults, severe overloads, or open-phase conductors in the power feeders from the generators to the electrical power center (EPC) is provided by current transformers (CT-E) to trip the associated generator relay (GR1). Other differential protection loops are provided to remove faults within the separate protected zones (GEN 1-DP and BUS TIE DP), according to the unique tripping control logic and sequence, by means of the GR-1 and BTR-1 power relays.

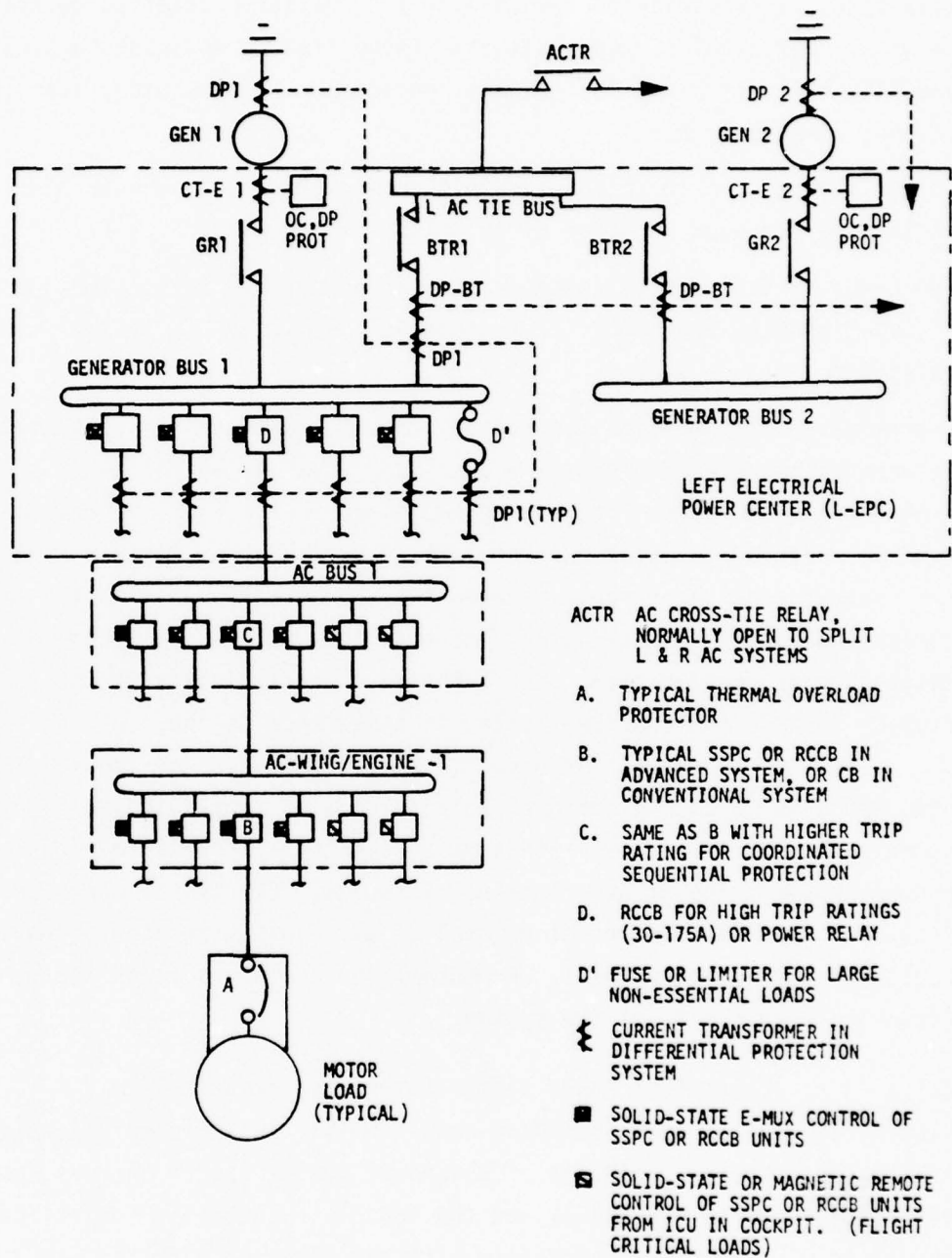

Figure 2-3. Electrical Power System Protective Device Coordination

This study is primarily concerned with the smaller protection devices in terms of electrical current ratings. These are the devices shown as "B" and "C" in Figure 2-3. The ratings considered for this study are 1.6A, 2A, 3A, 5A, 7.5A and 10A.

In the future, hybrid solid-state/electromagnetic devices with higher current ratings may be used in place of the RCCBs in locations C or D.

The E-MUX control design concepts may be used with both the SSPCs and with RCCBs which have been modified to provide a common 5 Vdc control circuit interface.

Coordination of the trip time versus current characteristics is necessary between each protective device and those preceding and following in the feeders from sources to loads. This is accomplished in aircraft by providing a 2:1 minimum ratio of tripping current ratings for adjacent circuit breakers. If the impedance of the circuit between the CBs is very small or the fault current capability is very high, increase to a 3:1 ratio may be justified to ensure proper coordination. The tripping characteristics of the SSPC specified by the MIL-P-81653 are similar in appearance to those of conventional CBs. The SSPC, however, introduces a series impedance of about 0.25 to 1.0 ohm, and some SSPCs are designed to provide a current-limiting function. Coordination of lower-level SSPCs must take this factor into account to ensure proper tripping and clearing of faults. Electrical power system integrity depends upon prompt removal of all faulted sections, leaving unfaulted sections operational. Promptness of action enhances the dynamic (transient) stability of the system.

2.1.2 Electrical Power System Interface Compatibility

Electrical power system interface compatibility is a design objective which will ensure that all elements of the power system (power sources, power distribution, components, loads, and the manual or automatic control circuits and logic) are mutually compatible with the SSPC and with the E-MUX hardware. Such compatibility is necessary before comparisons of SSPC or E-MUX components and their operating characteristics can be made. Perhaps of even more importance is compatibility of both technical functions and operational characteristics. This is necessary to permit consideration of the SSPC and/or E-MUX systems as viable candidates for trade study and eventual selection.

The ideal SSPC, from the aircraft designer's point of view, would permit a one-for-one substitution of the SSPC for the conventional CB. This ideal may be impractical, however, due to the isolated control and power switching sections required in the SSPC. The conventional CB obtains its control and operating energy from the current in the protected circuit. The SSPC must obtain its control and operating power from an independent and at least equally reliable source. The control and operating requirements are very small for the solid state design and a separate power supply for control power is a reasonable design approach. The power supply must have sufficient redundancy to achieve the required reliability for this essential function. A common power supply with redundancy or a backup power supply design may be used between SSPCs within a single SSPC panelboard. A fail-safe mode of control must be provided in the event of a loss of control power and to control SSPC functions upon eventual power restoration. Total loss of control power must be made both extremely unlikely and tolerable to be acceptable for transport aircraft application to essential electrical circuits.

The discussion of power system integrity in Section 2.1.1 covered the protection system of the transport aircraft. Inherent to that system is a requirement for compatibility of the interfaces between the several levels of protection. Such compatibility will ensure that preferential tripping of overloads and faults will occur at the desired level, with a minimum disturbance to the non-faulted buses and circuits. When an SSPC is the controlled switching element, the total time to clear a fault or an overload is much less than for an E-MUX-compatible RCCB or a conventional CB.

The computer-managed system has the capability to perform diagnostic analyses related to reclosing of high-level circuit breakers, and to sequential tripping/reclosing in order to identify and to locate low-level faults. The time periods required to collect information for pre-programmed algorithmic analysis and to issue the proper commands are very short compared to thermal, thermal-magnetic, or electromagnetic circuit breaker operations. This high characteristic operation speed encourages the use of the computer/EMUX system for the analytical and control operations necessary to restore "healthy" loads and distribution system elements to service.

2.1.3 Electrical Power System Cost

Electrical power system cost includes the non-recurring development cost, the recurring initial hardware cost, and the costs of operation, maintenance, repair, and replacement. It also includes such costs as may be incurred for unique interfacing hardware and environmental control equipment, such as cold-plating and/or cooling fans. These latter costs are limited to the hardware items which are needed specifically to incorporate the SSPC and E-MUX hardware into an operating aircraft system.

Cost considerations encourage the development of highly reliable components having a high degree of commonality and, further, encourage group installations of SSPCs on common PC cards and in common enclosures, as well as the development of universally applicable designs for SSPCs and E-MUX terminals. Design complexity and installation/removal complexity generally have unfavorable impacts on both initial and life-cycle costs, and are to be avoided.

The equivalent lifetime costs allocated to the SSPC/E-MUX system weight must be added to the direct costs of the installed system before making a trade study comparison with the same cost elements for a conventional CB system.

The average installed direct cost per pound for the DC-10 electrical power system, in 1978 dollars, is \$110.84/lb. This includes purchased parts, enclosures, wiring, and miscellaneous hardware. It also includes fabrication, assembly, installation, and functional testing.

The average lifetime cost for use in evaluating system alternatives on C-15 aircraft is \$400/lb. in 1978 dollars. This cost value is derived from the air transport operating data for a DC-10-10 aircraft of similar size for a twelve month period ending September 30, 1977. It is based upon total aircraft operating expenses (crew salaries, fuel, oil, taxes, insurance, maintenance, burden, original cost recovery through depreciation and rentals). These expenses are allocated on the basis of cost per block hour of operation. The average daily utilization in block hours is used to determine the total hours of operation and the total operating cost for a 20-year nominal operating lifetime. The average gross weight is then divided by this cost to obtain \$400/lb. as the average lifetime cost per pound of gross weight.

The value of a weight reduction of one pound in an airplane is basically the lifetime value of an additional pound of allowable payload. This is taken

as the lifetime saving of allocated expenses to fly one pound, measured over the 20-year nominal life of the airplane.

2.1.4 System Safety

System safety is a broadly defined term, having two major aspects for this study; maintenance personnel and crew/passenger safety, and probability of survival of the electrical system during battle conditions or other hazards. The former aspect has the highest priority in design and operation. The latter aspect is closely related to design for enhanced functional system reliability.

If an electrical power system possesses sufficient redundancy, emergency system capability, and alternative sources of energy, it can provide the crew with assurance that the aircraft can safely complete its mission, return to base, or complete a diversion and landing at an alternative air field. Provision for a high probability of mission completion therefore contributes directly to a high system safety evaluation. Therefore, E-MUX control system redundancy, load bus configuration design to provide ac and dc emergency buses and power sources, and manual control by the crew for flight-critical load circuits are provided for the C-15 aircraft system model.

2.1.5 Tolerance to Operational Aircraft Environments

Tolerance to operational aircraft environments refers to the capability of the components and their peripheral hardware to withstand the thermal, shock/vibration, and electrical/electromagnetic (faults, current surges and voltage spikes) environments. For military aircraft, the specified electromagnetic pulse (EMP) environments must be tolerated without loss of system integrity and with, at worst, a graceful degradation mode. The term "graceful degradation" refers to a system having a reduced capability, quality, or margin of performance and reliability, yet which remains fully functional after a single failure or event. This mode of degradation is desirable in preference to full failure for faults or system failures, but must be annunciated in an appropriate manner to alert the crew and maintenance personnel to the change of system status.

2.1.6 Impacts on Aircraft Electrical Power System Design

Impact on the aircraft electrical power system design is a particularly

important consideration when applying a new component or system to an existing aircraft, often discouraging its application entirely. For example, the relocation of panelboards and replacement/rerouting of existing wiring to accommodate a SSPC/E-MUX system would not be justified on an existing aircraft, because the costs would surely far outweigh the benefits. For a new aircraft in its advanced or early design phases, the inclusion of SSPCs and E-MUX/data-link/computer systems will naturally have some design impacts. These impacts can be manageable, even favorable, when addressed during the initial electrical power distribution system design. Sufficient favorable design impacts will represent the justification necessary for adopting a new design based on an SSPC/E-MUX system concept.

The thermal control provisions for SSPC panelboards and provisions for high reliability in the control power supplies to SSPCs or E-MUX terminals at remote panelboards represent two areas of design impact. These must be resolved satisfactorily to justify incorporation of the new design concepts.

2.1.7 Flexibility for Application to Diverse Electrical Circuits and Loads

Flexibility for application to diverse electrical circuits and loads is a necessary prerequisite to achieve the large volume of SSPC production and installation which is, in turn, necessary to achieve component cost reductions. This observation implies that the impacts on electrical system design necessary for accommodation by different aircraft with different generator current capabilities must be minimized, and that standardized modules, circuits, and component ratings, both SSPC and E-MUX, must be developed to increase the SSPC and E-MUX adaptability to future aircraft at lowest possible cost. SSPC designs which are usable for either ac or dc circuits, or are adjustable to operate at different trip ratings over a wide current range, will achieve the highest rating in trade studies for flexibility and lowest life cycle cost.

Each aircraft design model poses some unique switching and load transfer requirements. Transfer switching of power sources or of utilization load equipment from the primary to the back-up configuration suggests that a reversed binary command logic capability is desirable; a binary 1 command would then switch SSPC-A ON and SSPC-B OFF; while a binary 0 would reverse these switching states. This design provides a transfer relay function. If

positive separation of power sources must be assured to avoid momentary parallel operation, the status circuits may be interlocked with the control circuits of the alternate SSPC to require an OPEN status from SSPC #1 to enable a CLOSE command to reach the control circuit of SSPC #2, and vice versa.

2.2 MILITARY TRANSPORT ELECTRICAL SYSTEM REQUIREMENTS

The design requirements for the C-15 electrical power system have been expanded and supplemented by detailed requirements derived from the DC-10 commercial transport airplane. These requirements have been adapted for use in defining the SSPCs, SSPC panelboards, and the electrical multiplex (E-MUX) control system. These requirements also define the electrical system model and operating environment within which the SSPC would be operated and with which they must be compatible. The C-15 Military Transport System defined in MDC Specification 15S002, dated 25 Nov 1976, is used as the model for this study.

Background information which supports requirements applicable to SSPCs are identified in Para. 2.2.1, requirements for the electrical power distribution system are identified in Para. 2.2.2, and general requirements which relate directly to SSPC design/interfaces are listed in Para. 2.2.3. These requirements are supplemented in some cases to indicate the manner in which they should be interpreted and applied. Detailed design requirements for SSPCs are provided in Para. 2.2.4.

Additional requirements may be identified during the initial Phase II study if necessary to more accurately define the interfaces between the SSPCs and the other electrical hardware, the user's electrical loads, the working environment, and the military transport crew.

2.2.1 Electrical Power System Requirements

The following information is provided as background for the specific requirements for design of SSPCs to be used for individual load branch circuits.

(a) Electrical Power Subsystem

The electrical power subsystems shall consist of a 115/200 volt, 3 phase, 400 Hz ac supply and a 28 volt dc supply and shall supply electric power conforming with MIL-STD-704B. The subsystem shall have a continuous capacity which is at least twice the largest load existing

for an operational period of 15 minutes or longer, based on the load analysis of the initial production aircraft. The aircraft shall not lose all ac or dc primary electrical power as a result of any combination of two failures. From this requirement, it is concluded that the power system management function (E-MUX) must have sufficient redundancy to accept two failures, as a minimum, without terminating all primary electrical power. Indication to the crew via the caution and warning (alerting) system is needed for both the first and second failures.

(b) AC Power Supply

The ac power system shall be divided into two major subsystem sections, left ac system and right ac system. These are normally isolated, but may be connected after disconnecting the faulted portion of one section. An emergency ac bus shall be provided to supply essential, flight-critical loads. The ac distribution system shall be arranged such that power source priority is provided in the order of main generators first, APU generator second, and external power third.

(c) Generator

The generators shall be 40 KVA, 3 phase, 120/208 volt, 400 Hz brushless type generators. Future use of 1200 Hz generators and VSCF converters may be considered in the design of advanced SSPCs, but such an option is not included in this study.

(d) Constant Speed Drive

An axial gear differential type constant speed drive (CSD) shall be installed on the engine accessory drive pad to drive each main generator. A disconnect, electrically controlled by a switch in the flight deck, shall be provided for each CSD. The oil system shall be separate from the engine oil system.

(e) Auxiliary Power

One 40 KVA, 3 phase, 120/208 volt, 400 Hz generator, identical to the main engine generators, shall be mounted on the Auxiliary Power Unit (APU) to serve as a source of auxiliary electrical power on the ground or as back-up power in flight.

(f) External Power

It shall be possible to energize the air vehicle electrical circuits from an external 3 phase, 115/200 volt, 400 Hz power supply through an external power receptacle conforming to AN3114.

(g) DC Power Supply

The primary source of 28 volt dc power shall be the conversion of ac power through transformer rectifiers. The left and right main dc buses shall be normally isolated, but may be manually cross-tied. An emergency dc bus shall be provided to supply essential flight-critical loads. The battery bus shall normally receive power from both the left and right main dc buses and shall transfer to the battery on the failure of normal dc power.

(h) Emergency Power

A 28 volt, nickel-cadmium battery and charger system shall be installed to provide emergency electrical power and APU starting capability. A solid-state continuous duty inverter shall provide emergency ac power.

2.2.2 Electrical Power Distribution Subsystem Requirements

The following requirements are provided for distribution system protection, wiring and component design.

(a) System Protection

A fully coordinated protective system shall be provided and shall, in so far as practicable, discriminate between faulted and unfaulted components of the system and isolate the faulted components. The system shall be protected against shorts and grounds, open circuits, over and under voltage, under frequency and incorrect phase sequence. Circuit interlock protection shall be provided to prevent the connection of large loads to a single generator or combination of generators or the system.

(b) Wiring

Wire harnesses shall be installed in compliance with MIL-W-5088. Cable routing control and connector indexing shall be utilized to prevent improper mating of connectors.

(c) Connectors

General-purpose circular electrical connectors shall meet the requirements of MIL-C-83723 and MIL-C-38999 except where interfaces with GFP or other existing components may dictate special requirements. Coaxial connectors shall meet MIL-C-39012 requirements.

(d) Circuit Breakers

Trip-free type circuit breakers shall be used to prevent wire damage and to coordinate with other subsystem protective features. Circuit breakers located in the flight compartment shall be grouped by system and aligned by buses, with mixing of ac and dc avoided. This requirement is derived from the C-15 military transport and shall apply in all cases where SSPCs do not replace the thermal circuit breakers. Insofar as practical, the same requirements should be used for SSPC application (e.g. purpose, coordination, grouping, alignments, and avoidance of mixed ac and dc systems) at all locations.

2.2.3 General Requirements For SSPC Design And Electrical Power Subsystem Interfaces

The following requirements are provided for interfaces between SSPCs and the electrical power system.

(a) Power Neutral/Negative Reference

The aircraft structure shall be used as the normal negative or neutral (reference) side of the electrical power system and load circuits.

(b) Signal Isolation

Cross-connections between redundant electrical control/status signal paths shall be eliminated or minimized, and such systems shall be electrically isolated. Separate data buses, each dual-redundant, will be required and physically isolated for the left and right electrical power subsystems.

(c) Physical Separation

Wire runs and components in redundant power supply and control paths shall be physically separated. To meet this requirement, E-MUX terminals, feeders, SSPC panels, and data buses must be physically separated and isolated.

(d) Load Assignment

Loads shall be assigned specifically to one subsystem, either left or right. Redundancy shall be obtained by duplication of critical load functions, with one such load supplied by each separate electrical subsystem. Separate distribution circuits shall be used to supply power to such redundant load systems.

2.2.4 Detailed Requirements For SSPC Design And Electrical Power
Subsystem Interfaces

The following statements are provided to identify the functional, operational, technical, environmental, safety and general requirements imposed on the SSPC by the military transport application.

(a) Functional:

The SSPC shall provide consistent and repeatable circuit switching and overload (over-current) tripping characteristics. Means shall be provided to indicate that the passive protective features of the system are operative. This may be accomplished by either continuous or cyclic monitoring or by routine testing, and without disconnecting functional circuits.

Means shall be provided that will preclude the cycling of an SSPC supplying power to a faulted circuit or to a short-circuited power-using device. If SSPC reclosing is desired after an overload trip, it shall be provided under the control of external logic circuitry. Such logic will be used also in a lockout mode to prevent reenergizing the faulted circuit from an alternate source.

The status of any protective function network which is passive in any system operational mode shall be capable of being evaluated and displayed without disconnecting any electrical or mechanical connection.

Built-in-test (BITE) facilities shall be provided or available such that the malfunction of any line replaceable unit (LRU) can be appropriately displayed, either locally or remotely, after all power has been removed from the airplane. Power restoration to reactivate the display system may be considered in order to meet this requirement.

Signals extraneous to the proposed equipment which are considered necessary to the collection, processing, or display of BITE data will be allowable, but should be kept to a minimum. These signals shall not contribute to a reduction in reliability of the SSPC in performing its primary function and purpose.

The BITE concept may use the normal annunciation and status functions of the SSPC but, in addition, it must allow BITE verification of the functional readiness of the SSPC status function as well.

A manually initiated remote indication of the state of readiness of the SSPCs using the BITE facilities if deemed appropriate, is desirable for pre-flight test operations by the flight crew. A secondary mode is desirable to reduce pre-flight check time.

The SSPCs shall be designed to avoid:

- (1) Cycling due to a crew-initiated or automatically initiated action.
- (2) Uncontrolled closure or reclosure into a fault when the SSPC remote command status is CLOSE or ON. If reset manually, the SSPC control assembly may reset (reclose) only once upon a fault (if allowable); then it shall trip and remain tripped as long as the control switch is held manually in the RESET position. An equivalent logic shall be provided to minimize the system disturbance from reclosing into faulted electrical circuits if this function is performed automatically through the E-MUX system.

(b) Operational:

The status sensing and display circuit of the SSPC shall distinguish between an overload trip and a commanded trip, and shall retain such information until an over-ride or CLOSE command is given which resets the trip status logic.

The SSPC design lifetime shall be TBD hours and TBD cycles of operation, minimum. (Note: The aircraft design requirements are 20 years total elapsed time, including 5 years of shelf storage time for spare parts, 60,000 hours of flight time and 50,000 landings, plus appropriate

ground operation and maintenance time allowances. The average flight duration is assumed to be 1.2 hours.)

The SSPC protective circuits shall not cause undesired (nuisance) tripping of the SSPC when applied over the full range of aircraft electrical system operating conditions, including, but not limited to, engine startup and electrical bus switching. Undesired tripping due to voltage or current transients shall not occur in any operating mode. This restriction shall include, but not be limited to, faults in other circuits, circuit switching, bus paralleling, load variations, SSPC or RCCB resetting, engine speed transients, and generator frequency or voltage excursions permitted by MIL-STD-704B.

Nuisance lockouts of the SSPC shall not occur under any operating condition.

False triggering (defined as non-commanded change of state) of the SSPC shall not occur as the result of noise (EMI) coupled into output, input, or control conductors. The noise injection modes and the peak voltage content of transient voltage spikes shall be as prescribed in RTCA document DO-160, with 600V minimum in the pulse-forming coupled circuit.

(c) Technical:

The electrical power circuits shall be physically and electrically isolated from the control circuits within the SSPC and within any assembly of SSPCs.

The SSPC shall be compatible with electrical power sources which are in compliance with MIL-STD-704B, and with all aircraft electrical loads (unless specified otherwise).

The SSPC shall be compatible with the automatic electrical power management system (E-MUX) system terminals.

The SSPC shall be compatible with conventional thermal or thermal/magnetic circuit breakers used to protect the feeder conductors to the SSPC panels.

Proven design principles, materials, and construction are preferred to minimize special training or tools, and to minimize unusual maintenance/repair procedures.

When multiple SSPCs are supplied by common circuits or common sources of power, means for establishing redundancy shall be provided within a PC card or within a single SSPC panelboard.

Wire sizes shall be compatible with the maximum load current rating of the device. Internal protection shall be compatible with the smoke curves of the wire sizes used.

No copper wire smaller than AN24 shall be used. When used, AN24 shall be designed for crimped (not soldered) terminals, and strain relief shall be provided at connections.

No wire smaller than AN20 will be allowed in areas normally subject to high vibration or extreme environmental conditions.

No aluminum wire shall be used within the SSPC or the panelboard assembly.

All wiring within SSPC panelboards shall run in open harnesses, shall be well secured and supported, shall be without splices, and shall be physically secured by clamping at terminating ends, at terminal strips or near terminating connectors.

Where wiring goes through cutouts in structural elements, hard insulating grommets or equivalent protection shall be used.

The selection of microcircuit devices shall be limited to off-the-shelf items with proven reliability and performance. This requirement does not deny the use of newly-developed nor special LSI devices, for example, but such elements should be of assured supply or should be second-sourced.

Device maturity and standardization are a prerequisite, and it is recommended that the applicable sections of MIL-S-19500 be used as a guideline in the procurement of all microcircuit devices.

Provisions shall be incorporated in the solid-state assemblies' dielectric isolation to avoid effects of stray capacitance or leakage

circuits.

Internal reference grounds and provisions for external structural grounds shall be made such as to protect the SSPC and E-MUX logic elements and microcircuitry from stray fields, electromagnetic interference (EMI) with the SSPCs by external fields, or EMI by the SSPC upon external system elements.

(d) Environmental:

The SSPCs, SSPC panels and associated circuits shall be compatible with ambient temperatures from -40°F (-40°C) to +120°F (+49°C), with normal pressure altitudes from -1000 feet to +8500 feet above mean sea level (MSL) and shall withstand and remain functional for at least 10 minutes at an altitude of 42000 feet above MSL.

The environmental control provisions shall not require significant active heat removal techniques such as would impact the aircraft design or such that would impede or unduly complicate maintenance accessibility and procedures.

If active cooling means (e.g. liquid cold-plating, ducted air blowers, or fans) are required for operation under specified thermal environments, interlocking means shall be provided to prevent inadvertent operation under adverse conditions. Redundancy and/or appropriate override controls may be incorporated to permit SSPC operation when acceptable temperatures are restored or when other considerations permit time-limited or load-limited operation.

Forced air cooling may be provided in a separate enclosure or plenum for common support of several SSPCs within a common structure or panel.

Conduction cooling may use aircraft structure as a heat sink; however, temperatures of the aircraft surface skin and the outer or upper structural members may be well above 100°F in an unpowered ground storage mode; and further, adequate interfacing contact surfaces and heat flow paths must be available.

Convection cooling may use ambient air as a heat sink, provided that adequate heat transfer surfaces and/or fins and clear adjacent air spaces are available. The ambient air may be as high as 150°F in

some overhead compartments and in locations adjacent to the outer skin in an unpowered ground storage mode. The cockpit and cargo compartment may be up to 135°F when no power is supplied to the aircraft.

(e) Safety:

Logic signals and annunciation logic must provide 100% accuracy of information identifying the switching state (CLOSED, OPEN, or TRIPPED). Such information must remain valid upon loss of primary power to the SSPC; or, alternatively, the SSPC must OPEN upon loss of primary power.

Status information must remain valid, after removal of power from the SSPC, either by means of separate control/status circuit excitation or upon reapplication of primary power to the SSPC. Manual or manually-initiated means shall be available for closing and tripping the SSPC and for resetting the SSPC circuit status display. Manual reclosing shall clear or reset the power status display.

Opening or tripping the SSPC shall remove any voltage from the output which could be sensed by a maintenance crewman. If a low residual voltage is essential to the power switch, auxiliary means shall be provided to remove it in order that low-power logic or interlocking/sequencing circuits are not defeated.

Faults, overloads, or malfunctions within the LRU shall be removed by automatic protective devices or functions provided within the unit (LRU) or in common with a group of LRUs.

The SSPC design, assemblies, and operational characteristics shall be compatible with Federal Aviation Regulations (FARs), Part 25, 1 Feb. 1965, with Amendments 1 through 16, as currently revised/amended.

(f) Cost:

The potential hardware cost must be minimized to permit competitive comparisons with existing conventional power controllers.

Fault isolation and either repair or replacement at LRU level shall be possible within a period of 20 minutes for any failure mode and any location by a single maintenance crewman.

The design value used for weight reduction shall be \$400 per pound, based on life cycle cost and payload value. (See Para 2.1.3 for discussion).

The maintenance unit cost assumed for design shall be TBD per maintenance manhour (MMH) when performed off-aircraft.

(g) General:

The SSPC assembly and panels shall include complete provisions for unit/module thermal control, structural mounting/supports, physical protection, external electrical wiring connections (All-type connectors are standard), identification, and necessary local controls and interlocks. Provisions shall be made for status verification and functional testing in place without unit removal, although panel covers or terminal strip covers may be removed.

The panelboard enclosure and its associated electrical, structural, and mechanical features shall provide space for expansion sufficient for the future addition of 20 percent more SSPCs without relocation of the existing SSPCs.

The SSPC shall operate reliably within the acceptable current-vs.-time limits specified by MIL-P-81653 when supplied by power at an input terminal having the quality defined by MIL-STD-704B (re: overvoltage, undervoltage, overfrequency, underfrequency).

The SSPCs shall be grouped within the panelboard according to the controlled systems and shall be aligned by buses. AC and dc buses shall not be mixed within a single panelboard or a common enclosure.

The SSPCs or RCCBs which are essential to flight will have their controlling hardware (e.g. central computer terminal, E-MUX control center, or manual remote control switch) located in the flight compartment within reach of one or more crew members seated at a normal flight station.

If removable fuses or limiters are used, at least 50% spare fuses or limiters shall be provided and secured in an accessible adjacent location.

2.3 ELECTRICAL LOAD AND PANEL ANALYSIS

A major task of this study was to model the C-15 electrical power system in detail. This task included identification and physical location of the electrical loads, determination of the load circuit currents and the protective device (SSPC or RCCB) ratings, determination of SSPC spares requirements, location of the electrical panels, and sizing of the feeders to supply the panels.

The following paragraphs describe the study methods and provide the study results for the C-15 electrical system load and panel analyses.

2.3.1 Electrical Load Analysis

The C-15 electrical load analysis is partially derived from computer print-outs which show the type, voltage, number of phases, load criticality, and power factors of each electrical load. These also show the operating time during each phase of operation from aircraft loading to landing, during emergency and during ground service periods. The average power demands in Watts and Vars are also shown for each load, for 5 second (momentary), 5 minute (short-time), and 15 minute (sustained) periods of time; again for each aircraft operating condition. The operating power system load profile, in histogram format, shown in Figure 1-3, was derived from the original C-15 operational load analysis.

The C-15 program was discontinued prior to completion of its final load analysis. It was necessary for this study, therefore, to extrapolate appropriate data from DC-10 and DC-9 load analyses for similar loads known to be needed for the C-15 aircraft.

A detailed study was made of the locations of all the identified electrical loads of the C-15 airplane. The detailed load lists are contained in Appendix A, and the detailed load location listings are provided in Appendix B. Loads less than 0.5 ampere were listed only for critical categories or when these loads could be grouped for supply by a single SSPC (e.g. instrument lights).

2.3.2 Electrical Panel and Feeder Analysis

The SSPC or RCCB to control each load circuit was assigned to an appropriate

panel board located near the electrical center of the group of loads which it serves. Figure 2-4 shows the approximate locations of the panel boards.

The original locations for the Electrical Power Centers (EPCs) were in the bulkheads between the cockpit and the forward cargo bay, at Station 375. This location was initially established for the benefit of accessibility by the crew for conventional CB and RCCB units. The SSPC and RCCB design concept, however, would permit the EPCs to be located near the leading edge wing roots on each side of the cargo bay, at Station 675. This would save about 300 inches (25 feet) of AL 1/0 (3 wire) feeder for each generator. The optimum location, however, must also consider the added weight of feeders to the panels supplying the bulk of the loads and/or the load circuits from the panels. The primary location now selected for both EPCs is at Station 450, with an alternate location at Station 675 subject to future design review.

The SSPC or RCCB size (trip rating) was established for each load by the following procedure:

An ideal rating was determined for which the actual connected load would not exceed 75% of the trip rating. The proper SSPC/RCCB size was then selected to be the next larger standard rating from the following ampere ratings: 0.5, 1.6, 2.0, 3.0, 5.0, 7.5, 10, 15, 20, 25, 30, 40, 50, 75, 80, 100, 125, 150, 175, and 200. The underlined ratings are those for which the initial Telephonics SSPC designs are provided by this study. If the ideal size was very close to an SSPC rating, however, the closest size was selected (e.g. an 10A SSPC was selected for an ideal size of 10.6A to protect an 8.0A load). A derating factor of 80% conforms with acceptable aircraft design practice to avoid nuisance trips.

Ratings of 15A up to 100A are now expected to be RCCBs, although hybrid power controllers of these higher current ratings are presently being designed. Protective devices over 100A are presently power relays with overcurrent sensed by current transformers (CTs) and overcurrent (OC) relays, fuses for major loads, or limiters for feeders between buses.

The panel boards supplied by Generators 1 and 2 were located adjacent to one another on the left side of the airplane, in order to allow common E-MUX terminal control with the control power derived redundantly from both power

THIS PAGE IS BEST QUALITY PRACTICABLE
FROM COPY FURNISHED TO DDC

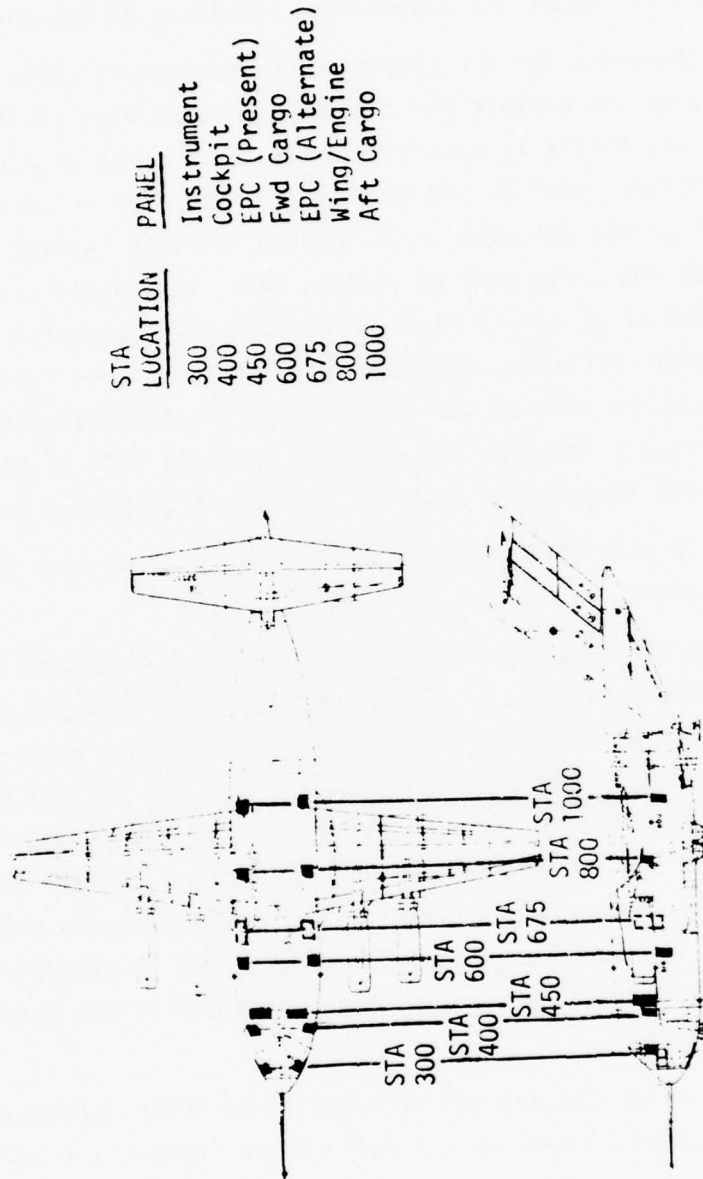

Figure 2-4. Panel Board Location Plan

sources. A similar arrangement was made on the right side of the airplane for panel boards supplied by Generators 3 and 4. Additional sources of control power can be derived from the co-located dc panels. A load summary for each panel board is provided in Appendices C and D. The load summaries provide the panel board and load identification codes, load currents, SSPC or RCCB trip ratings, SSPC sparing and spare current allowances, the total currents per panel (with spares), the panel feeder sizes, current capacities and the feeder lengths.

2.3.3 Electrical Panel Design Features

The load analysis shows that a variety of protection device sizes are required in each area, ranging from less than 0.5A to over 100A. In order to provide power supply feeder and bus efficiency, the panel boards should be designed with the flexibility to accommodate both SSPCs and E-MUX-compatible RCCBs. These may be located in common panel enclosures with configured bus connectors, or they may be located in adjacent panel sections with common bus-entrance designs to tie the feeder buses between the panels. A modular design based on multiples of four units (SSPC or RCCB) was used for the load and panel analysis. One concept for panel arrangement is shown in Figure 2-5 for E-MUX control of a single panel board. An alternate panel arrangement for E-MUX control of multiple co-located panel boards is shown in Figure 2-6.

Many loads are flight-critical loads for which a loss of control or power cannot be tolerated. Manual selection and control of these loads will be provided by the design now used for RCCBs, consisting of an Indicator Control Unit (ICU) in the cockpit. The ICU is a small push-button CB which controls the Trip/Close function of the RCCB and is tripped when the RCCB trips, indicating the state of the RCCB. This method, using 4-5 Vdc control voltage, is proposed for both SSPCs and RCCBs which serve flight-critical non-interruptible loads. The ac loads which are designated as flight essential and will be supplied by a separate emergency ac bus (PANEL AC-EMERGENCY BUS E) are listed in Table C-5. This bus will be supplied by Generator Bus 2 during normal conditions and by the Main Battery through the Emergency Inverter during an emergency operating condition. A ganged manually operated Emergency Power switch is used to simultaneously switch the Emergency Inverter to battery power supply, the DC Emergency Bus E to battery power supply, and the AC

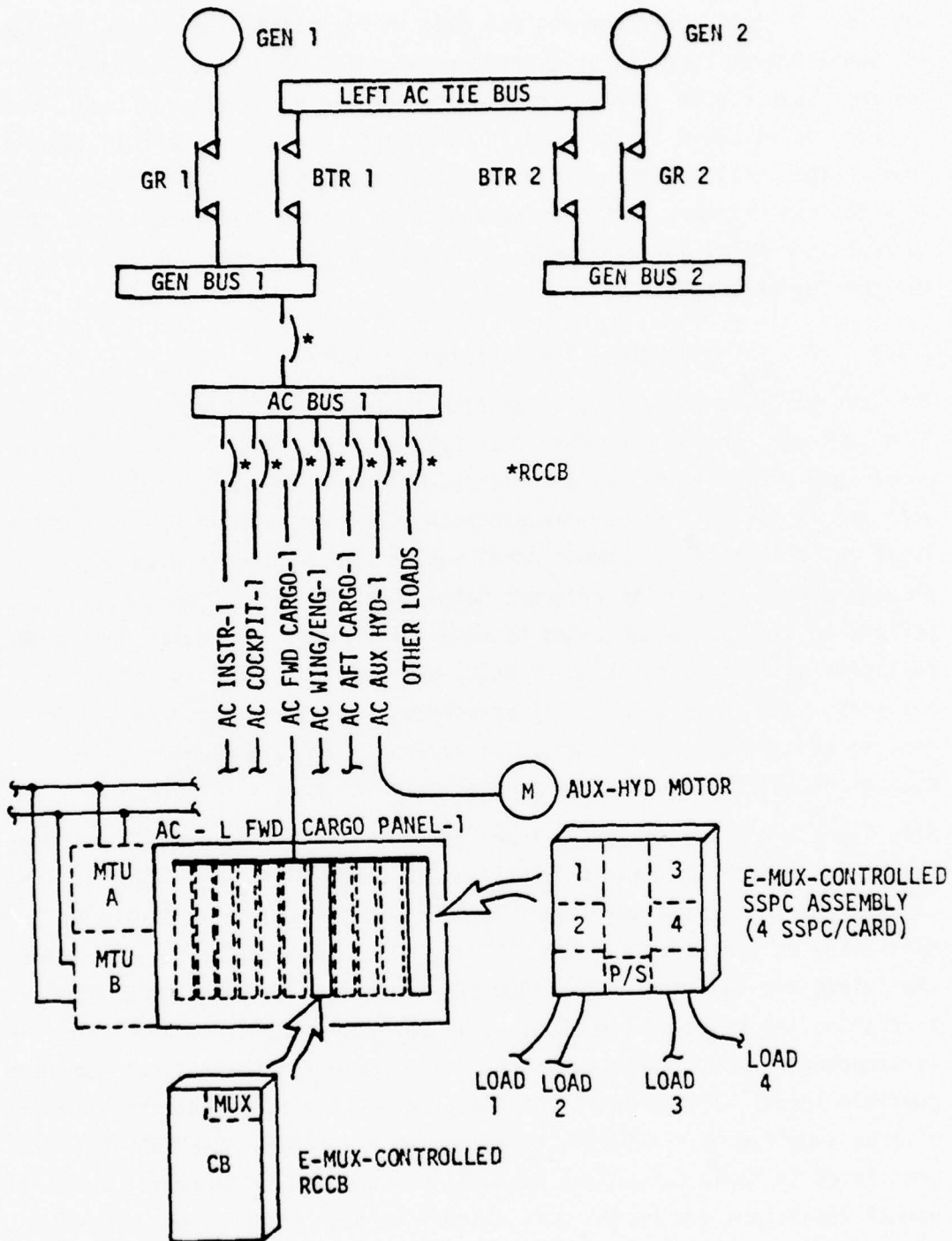

Figure 2-5. E-MUX-Controlled SSPC/RCCB Panel Board - Single

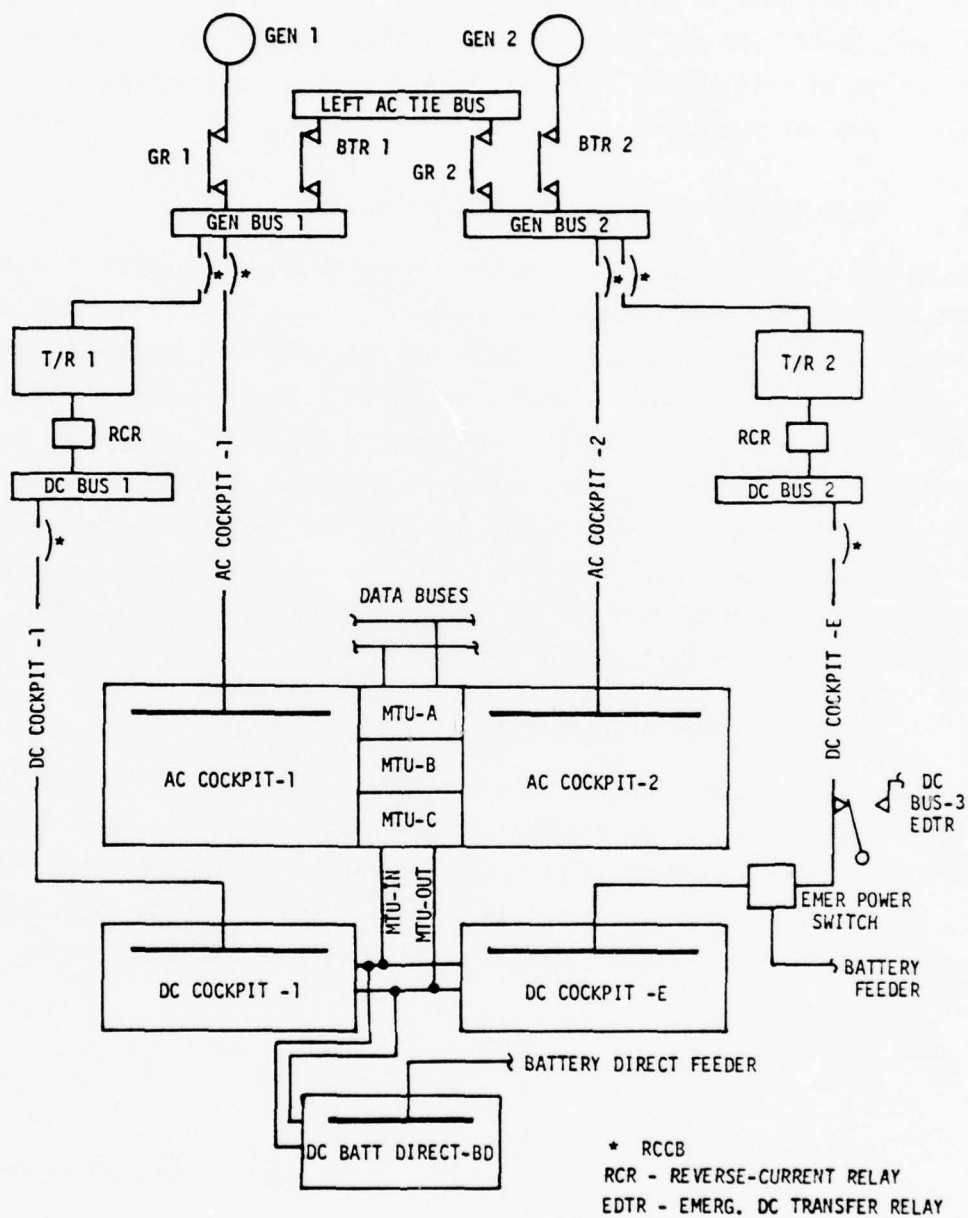

Figure 2-6. E-MUX-Controlled SSPC/RCCB Panel Boards - Multiple, Co-Located Panels

Emergency Bus AE to the Emergency Inverter. Flight-essential dc loads are similarly assigned to the emergency dc bus (PANEL DC-EMERGENCY BUS E), or to PANEL DC-BATTERY BUS BB or PANEL DC-BATTERY DIRECT BUS BD, according to the degree of criticality to flight or the need for battery power when engines are not operating.

2.4 ELECTRICAL SYSTEM FAULT CURRENT ANALYSIS

The designs of the SSPCs require a determination of the maximum expected fault currents under the worst fault conditions, in order to establish the tripping current duty requirements of the SSPCs for the specified system and generator capability. This task was accomplished for both three-phase and single-phase faults located at the electrical power centers (EPC) or at the SSPC panels. The subtransient symmetrical and asymmetrical fault currents (rms and peak instantaneous), the transient fault currents, and the steady-state fault currents were calculated. The effects of generator field-pole saliency, of a remote point of regulation at the EPC, and of a 100% pre-load of 40 KVA at 0.75 PF lagging were included in the calculations.

2.4.1 Generator Characteristics

The generator proposed for the C-15 airplane is the Lear Siegler P/N 31229 used on the DC-8 Series 60 airplane. Increased airflow for Class B cooling per MIL-G-6099A, Amendment 1, gives this generator a nominal rating of 30/40 KVA. The electrical characteristics for this generator were obtained from the manufacturer. This parametric data is based on a 40 KVA base rating.

Parametric Data:

X_{ad}	=	174.7%	R_2	=	7.05%
X_{aq}	=	103.0%	X_2	=	18.4%
X_l	=	11.8%	X_0	=	2.21%
X_d	=	186%	R_0	=	3.58% (est. from earlier DC-8 machine)
X_q	=	120%			
X'_d	=	27.6%			
X'_q	=	120% (with quad-axis damper bars)			
X''_d	=	18.1%			
X''_q	=	18.7%			

$$\begin{aligned}
T_{do} &= 0.215 \text{ sec} \\
T_a &= 0.0012 \text{ sec} \\
T'_d &= 0.0318 \text{ sec} \\
T''_d &= 0.005 \text{ sec} \\
R_{\text{stator}} &= 0.0355 \text{ ohm at } 20^\circ\text{C} \\
R_{\text{field}} &= 1.97 \text{ ohm at } 20^\circ\text{C} \\
\text{Eddy Factor} &= 1.1 - 1.0
\end{aligned}$$

2.4.2 Generator Internal Voltage (E_f)

- (a) With saliency, 100% pre-load at 1.0 PF, and fault at generator terminals.

$$E_f = 2.083 \angle 49.28^\circ \text{ p.u.} = 239.6 \angle 49.28^\circ \text{ volts}$$

- (b) With saliency, 100% pre-load at 0.75 PF, lagging and fault at generator terminals

$$E_f = 2.627 \angle 25.8^\circ \text{ p.u.} = 302.1 \angle 25.8^\circ \text{ volts}$$

This shows the reduction of real shaft power at 75% P.F., and the increase of internal excitation by 26% to maintain rated terminal voltage.

- (c) Similar conditions to (b), but a different method of computation is used to provide subtransient E''_f and I''_f , transient E'_f and I'_f , and steady state E_f and I_f for

$$E''_f = 1.1493 \angle 5.8^\circ \text{ p.u.} = 132.2 \angle 5.8^\circ \text{ volts}$$

$$I''_f = 6.3497 = 705.0 \text{ amperes}$$

$$E'_f = 1.168 \angle 25.9^\circ \text{ p.u.} = 134.3 \angle 25.9^\circ \text{ volts}$$

$$I'_f = 4.2334 \text{ p.u.} = 470.0 \text{ amperes}$$

$$E_f = 2.627 \angle 25.8^\circ \text{ p.u.} = 302.1 \angle 25.8^\circ \text{ volts}$$

$$I_f = 1.412 \text{ p.u.} = 156.8 \text{ amperes}$$

2.4.3 Conductor Impedances For C-15 Aircraft Model

#2 CU: $0.179 \Omega_{\text{dc}}$ at 20°C per 1000 ft

$$Z = 0.188 + j 0.206 \Omega / 1000' = 0.279 \angle 47.6^\circ \Omega / 1000'$$

#1/0 Al: 0.169Ωdc at 20°C per 1000 ft

$$Z = 0.188 + j 0.204\Omega/1000' = 0.277 \angle 47.3^\circ\Omega/1000'$$

2.4.4 C-15 Model Generator Feeder Impedances

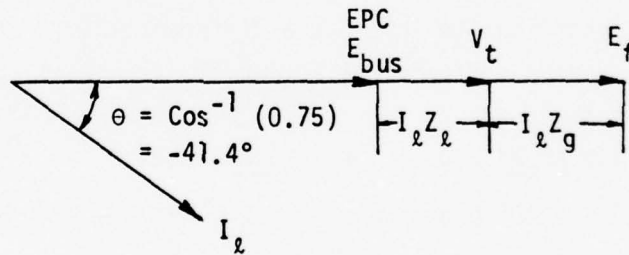
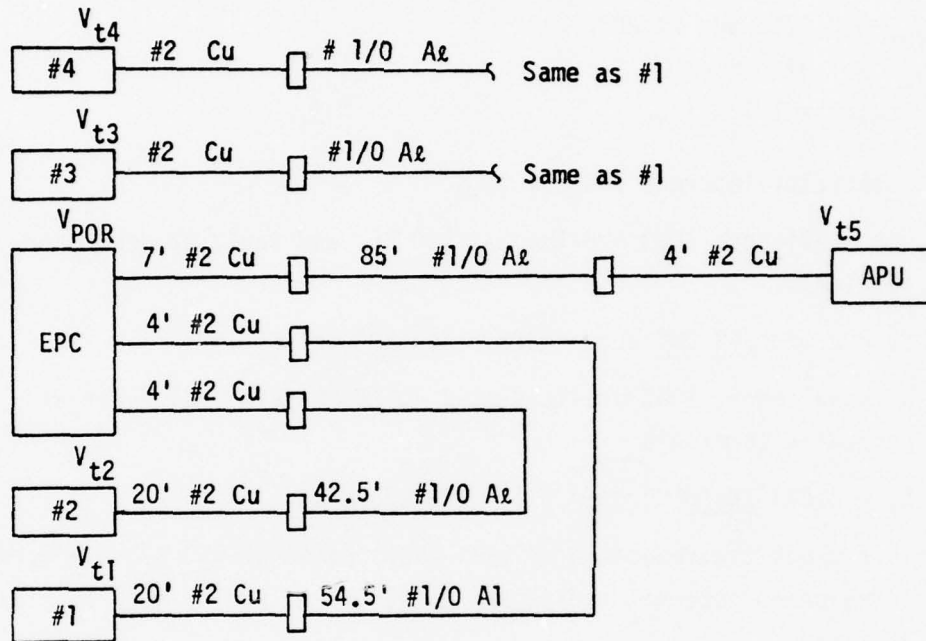

Remote Point of Regulation (POR) is at the ECP bus; then

$$E_{bus} = 1.0 \angle 0^\circ$$

$$\text{Generator \#1 or \#4: } R_{l1} + jX_{l1} = 14.76 + j 16.06 \text{ m}\Omega = 21.81 \angle 47.42 \text{ m}\Omega$$

Note: Voltage drop at rated $I = 111.03 \times 21.81 \times 10^{-3} = 2.42$ volts

$$\text{Generator \#2 or \#3: } R_{l2} + jX_{l2} = 12.5 + j 13.61 \text{ m}\Omega = 18.48 \angle 47.43^\circ \text{ m}\Omega$$

$$\text{APU Generator \#5: } R_{l5} + jX_{l5} = 18.06 + j 19.61 \text{ m}\Omega = 26.66 \angle 47.36^\circ \text{ m}\Omega$$

Terminal Voltages when EPC bus is POR:

$$V_{t1} = V_{t4} = IZ_1 + V_{POR} = 2.42/6.0^\circ + 115.0/0^\circ = 117.4 \text{ volts}$$

$$V_{t2} = V_{t3} = 2.05/6.0^\circ + 115.0/0^\circ = 117.4 \text{ volts}$$

$$V_{t5} = V_{APU} = 2.96/6.0^\circ + 115.0/0^\circ = 118.0 \text{ volts}$$

2.4.5 Three-Phase Fault at EPC with 100% Pre-Load

Three-Phase fault at the electrical power center (EPC) with 0.75 PF 100% pre-load and regulation at EPC:

$$E_f, E'_f, E''_f = 1.0 \angle 0^\circ \text{ at the EPC before the fault}$$

$$\text{Source } Z_f = Z_{gen} + Z_{line} = (Z_f, Z'_f, Z''_f) + Z_{line}$$

$$\text{Calculate } I_f, I'_f, I''_f = \frac{E_f, E'_f, E''_f}{(Z_f, Z'_f, Z''_f) + Z_{line}}$$

$$Z_{pu} = \frac{Z_{ohm} \text{ KVA}_{3\phi}}{1000 (KV_{ll})^2} = \frac{Z_{ohm} \times 40}{1000 (0.208)^2} = 0.9246 Z_{ohm}$$

$$I_{ll} = \frac{\text{KVA}}{\sqrt{3} \times KV_{ll}} = \frac{40}{\sqrt{3} \times 0.208} = 111.03 \text{ Amperes}$$

$$Z_{l1} = Z_{l4} = 0.0136 + j 0.0148 \text{ pu} = 0.0202 \angle 47.4^\circ \text{ pu}$$

$$Z_{l2} = Z_{l3} = 0.0116 + j 0.0126 \text{ pu} = 0.0171 \angle 47.4^\circ \text{ pu}$$

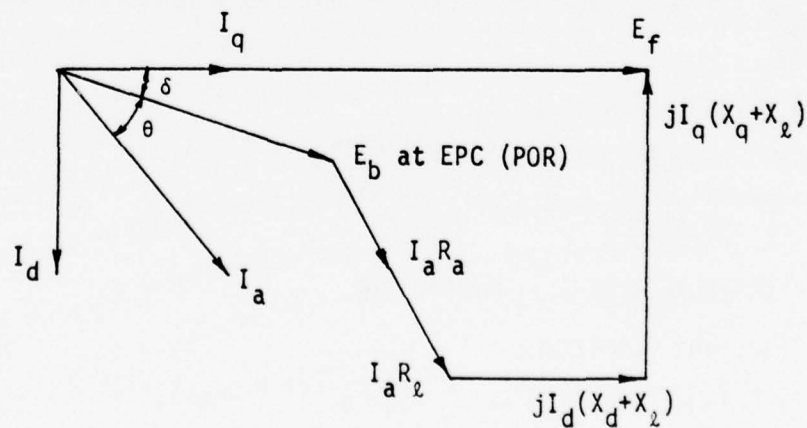

$$E_b = 1.0 \angle 0^\circ$$

$$I_a = 1.0 \angle -41.4^\circ = 0.75 - j 0.661 \text{ for } 1.0 \text{ pu load at } 75\% \text{ PF lagging}$$

$$\theta = -41.4^\circ; \delta = 25.64^\circ$$

$$I_d = I_a \sin |\delta + \theta| \angle -22.96^\circ = 0.9208 \angle -64.36^\circ$$

$$I_q = I_a \cos |\delta + \theta| \angle 67.04^\circ = 0.3901 \angle 25.64^\circ$$

$$R_{\text{stator}} = 0.0355 \Omega \text{ at } 20^\circ\text{C} = 0.9246 \times 0.0355 = 0.0328 \text{ pu}$$

- (a) Fault contribution for outboard generators #1 or #4.
(The detailed calculations are shown in subparagraph (b), and the results are listed below):

$$E_f'' = 1.1692 \angle 5.8^\circ \text{ pu}$$

$$I_f'' = 663.0 \angle -84.2^\circ \text{ A (symmetrical)} = 5.9714 \angle -84.2^\circ \text{ pu}$$

$$E_f' = 1.1874 \angle 25.6^\circ \text{ pu}$$

$$I_f' = 453.4 \angle -64.4^\circ \text{ A (symmetrical)} = 4.0832 \angle -64.4^\circ \text{ pu}$$

$$E_f = 2.6459 \angle 25.6^\circ \text{ pu}$$

$$I_f = 156.7 \angle -64.4^\circ \text{ A (symmetrical)} = 1.4113 \angle -64.4^\circ \text{ pu}$$

- (b) Detailed calculation of three-phase fault at EPC for generators #1 or #4:

$$R_{\Sigma 1} = 3.76 + 10.25 + 0.75 = 14.76 \text{ m}\Omega \times 0.9246 = 0.0136 \text{ pu}$$

$$X_{\Sigma 1} = 4.12 + 11.12 + 0.82 = 16.06 \text{ m}\Omega \times 0.9246 = 0.0148 \text{ pu}$$

The following assumes that δ is not significantly changed by R_e and X_e

Subtransient Condition:

$$E_f'' = E_{\text{bus}} + I_a (R_a + R_{\Sigma 1}) + jI_d (X_d'' + X_{\Sigma 1}) + jI_q (X_q'' + X_{\Sigma 1}) = 1.1692 \angle 5.8^\circ$$

$$I_f'' = \frac{E_f''}{j(X_d'' + X_{\Sigma 1})} = 5.9714 \angle -84.2^\circ \text{ pu} = 5.9714 \times 111.03 \angle -84.2^\circ$$

$$= 663.0 \angle -84.2^\circ \text{ A (symmetrical)}$$

Transient Condition:

$$E_f' = E_{\text{bus}} + I_a (R_a + R_{\Sigma 1}) + jI_d (X_d' + X_{\Sigma 1}) + jI_q (X_q' + X_{\Sigma 1})$$

$$= 1.1874 \angle 25.6^\circ$$

$$I_f' = \frac{E_f'}{j(X_d' + X_{\ell})} = 4.0832 \angle -64.4^\circ \text{ pu} = 4.0832 \times 111.03 \angle -64.4^\circ$$

$$= 453.4 \angle -64.4^\circ \text{ A (symmetrical)}$$

Steady-State Condition:

$$E_f = E_{\text{bus}} + I_a(R_a + R_{\ell}) + jI_d(X_d + X_{\ell}) + jI_q(X_q + X_{\ell}) = 2.6459 \angle 25.6^\circ$$

$$I_f = \frac{E_f}{j(X_d + X_{\ell})} = 1.4113 \angle -64.4^\circ \text{ pu} = 1.4113 \times 111.03 \angle -64.4^\circ$$

$$= 156.70 \angle -64.4^\circ \text{ A (symmetrical)}$$

Note: The dc decay (decrement) component depletes more rapidly than the subtransient current component, and the current envelope is symmetrical between phases at the time of the transient condition. Excitation increases the delivered current to 250A (symmetrical) for 5 seconds (guaranteed).

(c) Fault contribution from inboard generators #2 or #3.

$$E_f'' = 1.1642 \angle 6.1^\circ$$

$$I_f'' = 6.0134 \angle -83.9^\circ \text{ pu} = 667.7 \angle -83.9^\circ \text{ A (symm)}$$

$$E_f' = 1.1845 \angle 25.6^\circ$$

$$I_f' = 4.1043 \angle -64.4^\circ \text{ pu} = 455.7 \angle -64.4^\circ \text{ A (symm)}$$

$$E_f = 2.6431 \angle 25.63^\circ$$

$$I_f = 1.4114 \angle -64.4^\circ \text{ pu} = 156.7 \angle -64.4^\circ \text{ A (symm)}$$

The formulas to arrive at the above equalities are the same as used in subparagraph (b), except that:

$$R_{\ell 2} = 12.5 \text{ m}\Omega = 12.5 \times 0.9246 = 0.0116 \text{ pu}$$

$$X_{\ell 2} = 13.61 \text{ m}\Omega = 13.61 \times 0.9246 = 0.0126 \text{ pu}$$

(d) Fault contribution from APU generator #5:

Using the same formulas of subparagraph (b), but with:

$$R_{\ell 5} = 18.06 \text{ m}\Omega \times 0.9246 = 0.0167 \text{ pu}$$

$$X_{\ell 5} = 19.61 \text{ m}\Omega \times 0.9246 = 0.0181 \text{ pu}$$

Then:

$$E_f'' = 1.1738 \angle 5.8^\circ$$

$$I_f'' = 5.8955 \angle -84.2^\circ \text{ pu} = 654.6 \angle -84.2^\circ \text{ A (symmetrical)}$$

$$E_f' = 1.1916 \angle 25.5^\circ$$

$$I_f' = 4.0517 \angle -64.5^\circ \text{ pu} = 449.9 \angle -64.5^\circ \text{ A (symmetrical)}$$

$$E_f = 2.6502 \angle 25.6^\circ$$

$$I_f = 1.4111 \angle -64.4^\circ \text{ pu} = 156.7 \angle -64.8^\circ \text{ A (symmetrical)}$$

(e) Asymmetry and Time Constants

$T_{ax} = 0.0022 \text{ sec (calculated)} \cong 1 \text{ cycle}$ required for the dc offset current due to asymmetry to decay to $1/e$ of its original value

$T_{dx}'' = 0.005 \text{ sec} \cong 2 \text{ cycles}$ for subtransient ac current to decay to $1/e$ of the difference between I_f'' and I_f'

$T_{dx}' = 0.0318 \text{ sec} \cong 12 \text{ cycles}$ for the transient ac current to decay to $1/e$ of the difference between I_f' and I_{ss} .

$$T_{a1} = T_{a4} = \frac{X_2 + X_{l1}}{2\pi f(ra + r_{l1})} = 0.0017 \text{ sec} \cong 3/4 \text{ cycle for dc decay with line impedance}$$

$$T_{a2} = T_{a3} = \frac{X_2 + X_{l2}}{2\pi f(ra + r_{l2})} = 0.0018 \text{ sec}$$

$$T_{d1}'' = T_{dx}'' \frac{ra (X_d'' + X_{l1})}{X_d'' (ra + r_{l1})} = 0.0038$$

$$T_{d2}'' = 0.0040 \text{ sec} \cong 1.6 \text{ cycle}$$

The peak instantaneous value of the current envelope with 100% symmetry, due to a fault occurring at the moment of peak current in one phase, is obtained by multiplying the symmetrical current values by the factor $2\sqrt{2} = 2.828$. This value occurs only at the initial moment of fault ($t = 0$). The effect of asymmetry decays to $1/e$ of its initial value in T_{ax} seconds. The value I'' decays toward I' with a time constant T_{dx}'' , and I' decays toward I_{ss} with a time constant of T_{dx}' . The asymmetry thus produces peak instantaneous current of $2\sqrt{2} I_x''$ or

maximum rms current of

$$\sqrt{(\sqrt{2}I_x'')^2 + (I_x'')^2} = \sqrt{3I_x''^2} = \sqrt{3}I_x''$$

The complete equation for the asymmetrical rms current envelope, as shown in Figure 2-7, is:

$$I_{x\text{rms}} = (\sqrt{3}-1)I_x''e^{-t/T_{ax}} + (I_x''-I_x')e^{-t/T_{xe}''} + (I_x'-I_{xss})e^{-t/T_{xe}'} + I_{ss}$$

$$T_d' = 0.0318 \text{ sec}$$

With external circuit resistance r_e and reactance X_e :

$$T_{de}' = T_d' \frac{(X_d)}{(X_d')} \frac{(X_d'+X_e)}{(X_d+X_e)} = 0.032 \frac{(1.86)}{(0.276)} \frac{(0.276 + X_e)}{(1.86 + X_e)}$$

For generator #1 & #4: $X_e = 0.016$, $\therefore T_{de1,4}' = 0.034 \text{ sec}$

For generator #2 & #4: $X_e = 0.014$, $\therefore T_{de2,3}' = 0.033 \text{ sec}$

For APU generator #5: $X_e = 0.020$, $\therefore T_{de5}' = 0.034 \text{ sec}$

For generators 1 & 4:

Max asymmetrical current (rms) = $\sqrt{3} \times 663.0 = 1148.3 \text{ A rms}$

Peak instantaneous current = $2\sqrt{2} \times 663.0 = 1875.2 \text{ A peak}$

(f) Paralleled generator short circuit capability at electrical power center (EPC).

The total current values for either the left EPC (generators 1 and 2) or the right EPC (generators 3 and 4) are:

$$\text{Total } I_f'' = I_{f1}'' + I_{f2}'' = 1330.7 \angle -84.1^\circ \text{ A (symm), subtransient}$$

$$\text{Total } I_f'' \text{ (max inst)} = 2\sqrt{2} I_f'' = 3763.2 \text{ A peak inst, asymmetrical}$$

$$\text{Total } I_f'' \text{ (max rms)} = \sqrt{3} I_f'' = 2304.8 \text{ A rms, max asymmetrical}$$

$$\text{Total } I_f' = 909.1 \angle -64.4^\circ \text{ A (symm), transient (because}$$

$T_{ax} \ll T_{dx}''$, the transient current will have negligible asymmetry)

$$\text{Total } I_f = 313.4 \text{ A steady-state}$$

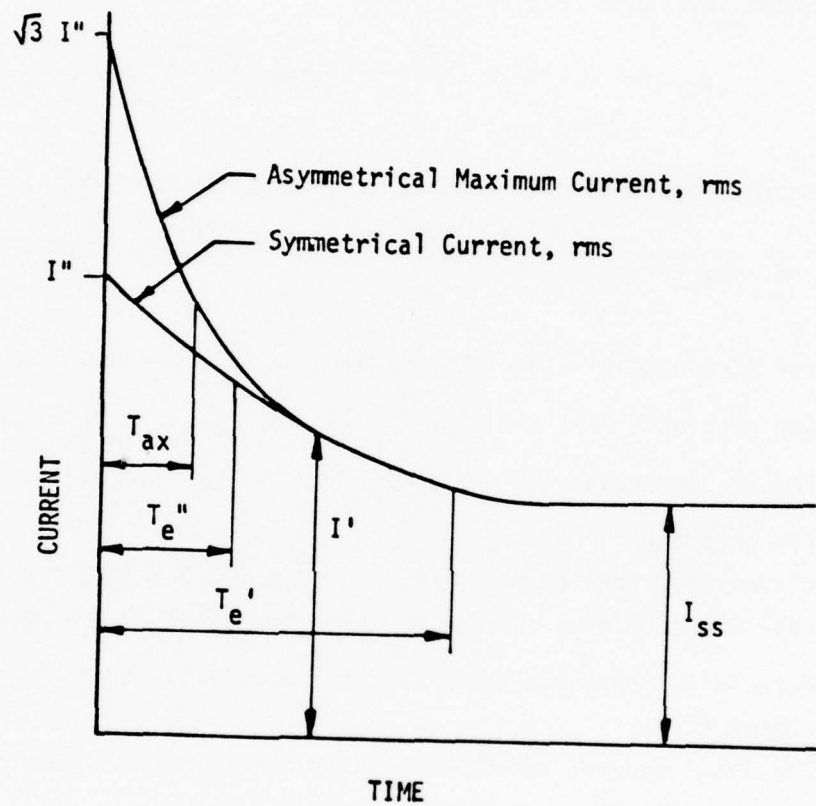

$$I_{\text{rms}} = (\sqrt{3} - 1)I''e^{-t/T_{ax}} + (I'' - I')e^{-t/T_{e''}} + (I' - I_{ss})e^{-t/T_{e'}} + I_{ss}$$

Figure 2-7. Fault Current Characteristics, RMS Values

2.4.6

Three-Phase Fault at the EPC and no Pre-Load

The effect of pre-load in paragraph 2.4.5 was to increase the generator field excitation, thus producing maximum currents to the faults. Because the generators are not normally operating at full rated load, the range of possible fault currents is from no pre-load to full pre-load. The method of calculation is the same as in paragraph 2.4.5. The results in (a), (b), and (c) below are comparable with paragraph 2.4.5 (a), (b), and (f) respectively.

(a) Fault Contribution from Generators 1 or 4:

$$E_{f_1}'' = 1.1493 \angle 5.8^\circ \text{ pu}$$

$$I_{f_1}'' = 5.7115 \angle -70.9^\circ \text{ pu} = 634.2\text{A (symm)}$$

$$E_{f_1}' = 1.168 \angle 25.9^\circ \text{ pu}$$

$$I_{f_1}' = 3.9663 \angle -55.0^\circ \text{ pu} = 440.4\text{A}$$

$$E_f = 2.627 \angle 25.8^\circ \text{ pu}$$

$$I_f = 1.4008 \angle -62.8^\circ \text{ pu} = 155.5\text{A}$$

(b) Fault Contribution from Generators 2 or 3:

$$E_{f_2}'' = 1.1493 \angle 5.8^\circ \text{ pu}$$

$$I_{f_2}'' = 5.7862 \angle -71.3^\circ \text{ pu} = 642.4\text{A (symm)}$$

$$E_{f_2}' = 1.168 \angle 25.9^\circ \text{ pu}$$

$$I_{f_2}' = 4.0001 \angle -55.4^\circ \text{ pu} = 444.1\text{A}$$

$$E_{f_2} = 2.627 \angle 25.8^\circ \text{ pu}$$

$$I_{f_2} = 1.4022 \angle -62.5^\circ \text{ pu} = 155.7\text{A}$$

(c) Paralleled Generator Short Circuit Current Capability at the Electrical Power Center, with No Pre-Load:

The total current values for either the left or the right EPC with two generators paralleled in each EPC is:

$$I_f'' = 1276.6 \angle -71.1^\circ \text{ A (symmetrical)}$$

$$I_f'' \text{ (max inst)} = 3610.8 \text{ A peak instantaneous, symmetrical}$$

$$I_f'' \text{ (max rms)} = 2211.1 \text{ A max rms, asymmetrical}$$

$$I_f' = 884.5 \angle -55.2^\circ \text{ A transient}$$

$$I_f = 311.2 \angle -62.7^\circ \text{ A steady-state}$$

2.4.7 Single-Phase Fault at EPC with 100% Pre-Load
Single-Phase to ground fault at electrical power center, with 100% (40KVA) pre-load at 0.75 PF lagging.

$$Z_1 = Z_{q1}' + Z_{e1} = \text{Positive Sequence Impedance}$$

$$Z_2 = Z_{q2} + Z_{e2} = \text{Negative Sequence Impedance}$$

$$Z_0 = Z_{q0} + Z_{e0} = \text{Zero Sequence Impedance}$$

$$E_f = \text{Voltage at POR (EPC) before the fault}$$

$$I_f'', I_f', I_f = \frac{3(E_f'', E_f', E_f)}{(Z_1'', Z_1', Z_1) + Z_2 + Z_0}$$

(a) Fault Contribution from generators #1 or #4:

The values for excitation voltages (E_f'' , E_f' , E_f) are listed in paragraph 2.4.5 (a). All values are in per unit.

$$R_1 = R_a = 0.0328$$

$$X_d = 1.86$$

$$R_1 = 0.0136$$

$$X_{d1} = 0.0148$$

$$R_2 = 0.0652$$

$$X_2 = 0.184$$

$$R_{l2} = 0.0136$$

$$X_{l2} = 0.0148$$

$$R_o = 0.0331$$

$$X_o = 0.0201$$

$$R_{lo} = 0.0268$$

$$X_{lo} = 0.0834$$

$$X_d' = 0.276$$

$$X_d'' = 0.181$$

$$I_f'' = \frac{3E_f''}{\sum R_f + j \sum X_f''} = 6.577 \angle -63.9^\circ \text{ pu} = 730.32 \angle -63.9^\circ \text{ A}$$

$$I_f' = \frac{3E_f'}{\sum R_f + j \sum X_f'} = 5.7158 \angle -47.2^\circ \text{ pu} = 634.6 \angle -47.2^\circ \text{ A}$$

$$I_f = \frac{3E_f}{\sum R_f + j \sum X_f} = 3.6296 \angle -59.5^\circ \text{ pu} = 403.0 \angle -59.5^\circ \text{ A}$$

(b) Single-Phase Fault Contribution from Generators 2 or 3:

$$R_1 = R_a = 0.0328 \text{ pu}$$

$$X_d = 1.86$$

$$R_{e1} = 0.0116$$

$$X_{e1} = 0.0126$$

$$R_2 = 0.0652$$

$$X_2 = 0.184$$

$$R_{e2} = 0.0116$$

$$X_{e2} = 0.0126$$

$$R_o = 0.0331$$

$$X_o = 0.0211$$

$$R_{eo} = 0.0228$$

$$X_{eo} = 0.0710$$

$$X_{d'} = 0.275$$

$$X_{d''} = 0.181$$

Using the same formulas as in subparagraph (a):

$$I_f'' = 6.9114 \angle -66.9^\circ \text{ pu} = 767.4 \angle -66.9^\circ \text{ A}$$

$$I_f' = 5.9539 \angle -50.1^\circ \text{ pu} = 661.1 \angle -50.1^\circ \text{ A}$$

$$I_f = 3.6586 \angle -60.5^\circ \text{ pu} = 406.2 \angle -60.5^\circ \text{ A}$$

- (c) Paralleled Generator Short Circuit Current Capability For Single-Phase Fault at EPC after 100% Pre-Load at 0.75 PF Lagging. The total current values at either the left or right EPC with two generators paralleled in each EPC are:

$$\text{Total } I_f'' = I_{f_1}'' + I_{f_2}'' = 1497.2 \angle -65.5^\circ \text{ A (symm) in faulted phase}$$

$$\text{Total } I_f'' \text{ peak inst.} = 2\sqrt{2} I_f'' = 4234.1 \text{ A peak inst, asymm.}$$

$$\text{Total } I_f'' \text{ max rms} = \sqrt{3} I_f'' = 2593.2 \text{ A rms max asymm.}$$

Time constant $T_{ax} = 0.0022 \text{ sec} \approx 1 \text{ cycle}$ for dc decay to symmetrical values, and $T_{dx}'' = 0.005 \text{ sec} \approx 2 \text{ cycles}$ for subtransient current decay.

$$\text{Total } I_f' = 1295.7 \angle -48.7^\circ \text{ A}$$

$$\text{Total } I_f = 809.2 \angle -60.3^\circ \text{ A}$$

2.4.3 Fault Current Calculations Summary

The summaries of three-phase fault currents and time constants at the electrical power center are tabulated in Table 2-2. The summaries of single-phase fault currents and time constants are listed in Table 2-3. Both tables are shown graphically as functions of time in Figure 2-8.

TABLE 2-2
THREE-PHASE FAULT CURRENTS AT EPC

	<u>GEN 1 & 4 Individual</u>	<u>GEN 2 & 3 Individual</u>	<u>EPC L & R Total</u>
<u>Preload, 100%, 0.75PF</u>			
Subtransient, I_f'' , Symmetrical	663 \angle -84.19°	667.7 \angle -83.92°	1330.7 \angle -84.05°A
Subtransient rms Asymmetric Peak	1148.3A	1156.5A	2304.8A
Subtransient inst Asymmetric Peak	1875.2A	1888.5A	3763.2A
Time Constant t_{de}	0.0038 sec	0.0040 sec	0.0039 sec
DC Decrement I_{dc}''	937.6 A	944.3 A	1881.9A
Time Constant T_{ac}	0.0022 sec	0.0022 sec	0.0022 sec
Transient, I_f'	453.4 \angle -64.43°A	455.7 \angle -64.39°A	909.1 \angle -63.41°A
Time Constant T_{de}'	0.034 sec	0.033 sec	0.033 sec
Steady State, I_f	156.7 \angle -64.39°A	156.7 \angle -63.37°A	313.4 \angle -64.38°A
<u>No Preload*</u>			
Subtransient I_f'' Symmetrical	634.2 \angle -70.87°A	642.4 \angle -71.28°A	1276.6 \angle -71.07°A
Subtransient rms Asymmetric Peak	1098.4A	1112.6A	2211.1A
Subtransient inst. Asymmetric Peak	1793.8A	1817.0A	3610.8A
Transient, I_f'	440.4 \angle -55.03°A	444.1 \angle -55.35°A	884.5 \angle -55.19°A
Steady State, I_f	155.5 \angle -62.83°A	155.7 \angle -62.48°A	311.2 \angle -62.65°A

*Time constants are approximately equal for either preload or no preload condition.

NOTES:

1. No adjustment has been made for the voltage regulator buildup, which could provide 3.0 pu current (steady state) to the fault. This would be about 333A per generator or 666A at the EPC. The guaranteed short circuit capability is 250A for 5 seconds..
2. The SSPC will act as a current-limiter in the circuit for load-side faults. The values of fault currents calculated for the EPC should be used to describe the source short circuit capability (SCC) supplying the feeders to the local SSPC panels. Therefore, further fault current calculations are required when the panelboard feeders and SSPC series impedances have been determined. These calculations are in paragraphs 2.4.9 - 2.4.11.

TABLE 2-3

SINGLE-PHASE FAULT CURRENTS AT EPC

	<u>Gen 1 & 4 Individual Amperes</u>	<u>Gen 2 & 3 Individual Amperes</u>	<u>EPC L & R Total Amperes</u>
<u>Preload, 100%, 0.75 PF</u>			
Subtransient I_f'' Symmetrical	730.3/-63.88°	767.4/-66.94°	1497.2/-65.45°
Subtransient rms Asymmetrical, Peak	1264.9	1329.1	2593.2
Subtransient inst. Asymmetrical, Peak	2065.6	2170.5	4234.7
Time Constant T_{de}''	0.0038 sec	0.0040 sec	0.0039 sec.
Transient I_f'	634.6/-47.15	661.1/-50.07°	1295.7/-48.7°
Time Constant T_{de}'	0.033 sec	0.033 sec	0.033 sec
Steady State I_f	403.0/-50.53°	406.2/-60.47°	809.2/-60.34°

NOTES:

1. No adjustment has been made for the voltage regulator buildup, which could provide 3.0 pu current (steady state) to the fault. This would be about 333A per generator or 666A at the EPC. The guaranteed short circuit capability is 250A for 5 seconds.
2. The SSPC will act as a current-limiter in the circuit for load-side faults. The values of fault currents calculated for the EPC should be used to describe the source short circuit capability (SCC) supplying the feeders to the local SSPC panels. Therefore, further fault current calculations are required when the panelboard feeders and SSPC series impedances have been determined. These calculations are in paragraphs 2.4.9 - 2.4.11.

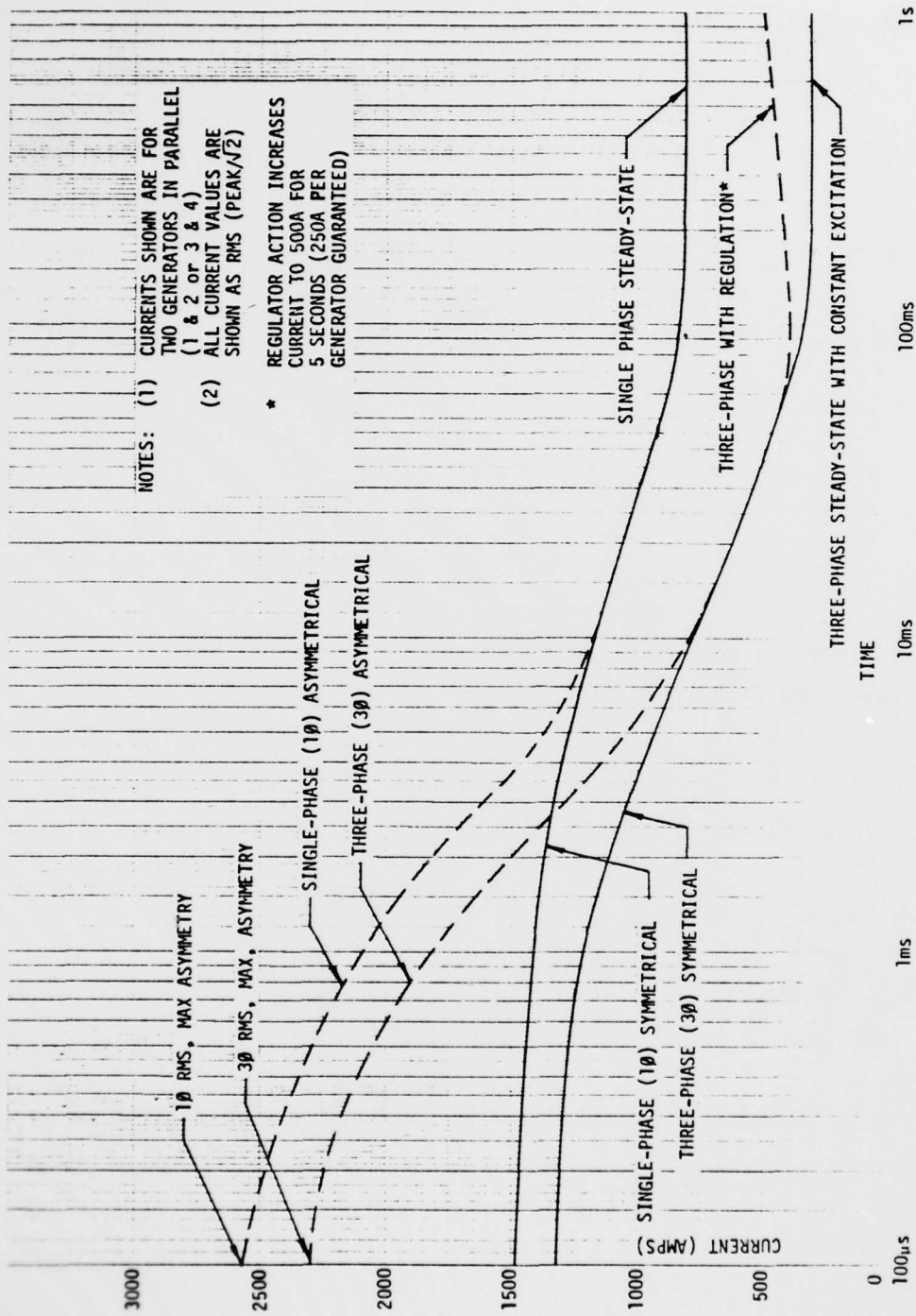
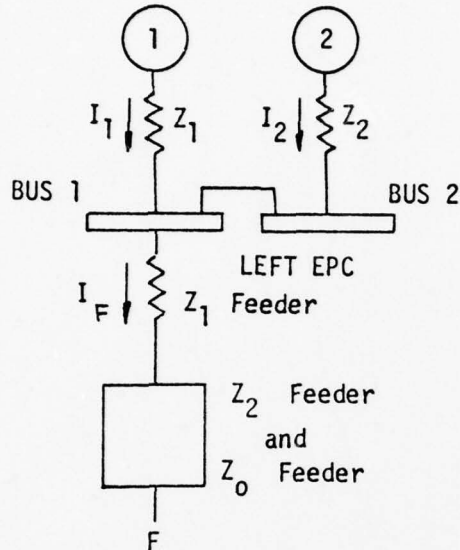

Figure 2-8. Electrical Power Center Fault Current Characteristics

2.4.9 Panel Board Fault Currents

(a) Fault Model



$$\sum I_{\text{source}} = I_1 + I_2 = \text{Parallel Short Circuit Capability (SCC)}$$

Equivalent Parallel Source Impedance

$$Z_{\text{source}} = \frac{1.0/0^\circ}{I_{\text{source}}} = \frac{1.0/0^\circ}{\text{SCC}}$$

(b) Equations for Fault Calculations:

Three-phase faults:

$$I_{F3\phi} = \frac{1.0/0^\circ}{Z_F} = \frac{1.0/0^\circ}{Z_{\text{source}} + Z_{\text{feeder}}}$$

Single-phase faults: (subscript s = source; fdr = feeder)

$$(I_F'', I_F', I_F)_{1\phi} = \frac{3 \times 1.0/0^\circ}{(Z_{1s}'', Z_{1s}', Z_{1s}') + Z_{1fdr} + Z_{2s} + Z_{2fdr} + Z_{os} + Z_{ofdr}}$$

(c) Source Impedance Calculations for Three-Phase Faults at Panel Board X

Subtransient Source Impedance, Z'' source:

$$\text{SCC}'' = \sum I'' = 1330.7 \angle -85.1^\circ \text{ A} = \frac{1330.7}{111.03} = 11.985 \angle -85.1^\circ \text{ pu}$$

$$Z''_{\text{source}} = \frac{1.0/0^\circ}{11.985 \angle -85.1^\circ} = 0.0834 \angle 85.1^\circ \text{ pu}$$

Transient Source Impedance, Z' source:

$$\text{SCC}' = \sum I' = 909.1 \angle -64.4^\circ \text{ A} = \frac{909.1}{111.03} = 8.1879 \angle -64.4^\circ \text{ pu}$$

$$Z'_{\text{source}} = \frac{1.0/0^\circ}{8.1879 \angle -64.4^\circ} = 0.1221 \angle 64.4^\circ \text{ pu}$$

Steady-State Source Impedance, Z_{source} :

$$\text{SCC} = \sum I = 313.4^\circ \angle -64.4^\circ \text{ A} = \frac{313.4}{111.03} = 2.8227 \angle -64.4^\circ \text{ pu}$$

$$Z_{\text{source}} = \frac{1.0/0^\circ}{2.8227 \angle -64.4^\circ} = 0.3543 \angle 64.4^\circ \text{ pu}$$

(d) Fault Current Calculations for Three-Phase Faults at Panel Board X

Assume the feeder conductors to a representative Panel Board X are closely bundled, composed of 3 #AN4 conductors, and located 2 inches above the ground plane. For such a feeder the impedance characteristics are:

$$Z_1 = 0.282 + j 0.212 = 0.3526 \angle 36.9^\circ \text{ ohm}/1000'$$

$$Z_2 = 0.282 + j 0.212 = 0.3526 \angle 36.9^\circ \text{ ohm}/1000'$$

$$Z_0 = 0.474 + j 1.33 = 1.4119 \angle 70.4^\circ \text{ ohm}/1000'$$

If the length is 100 ft and the maximum current trip rating of the feeder is 80A, the maximum voltage drop in the feeder is 2.8208 volts.

The per unit values for AN4 feeder in positive-sequence (Z_1), negative sequence (Z_2), and zero-sequence (Z_0) impedances are:

$$Z_1 = Z_2 = 0.3260 \angle 36.9^\circ \text{ pu}/1000'$$

$$Z_0 = 1.3054 \angle 70.4^\circ \text{ pu}/1000'$$

The assumed length of the feeder is 100 feet, for which the feeder sequence impedances are:

$$Z_{1X} = Z_{2X} = 0.0326 \angle 36.9^\circ \text{ pu} = 0.0261 + j 0.0196$$

$$Z_{0X} = 0.1305 \angle 70^\circ \text{ pu} = 0.0446 + j 0.1226$$

Subtransient Current:

$$I''_f = \frac{1.0/0^\circ}{Z''_{\text{source}} + Z_1} = 9.265 \angle -72.1^\circ \text{ pu}$$

$$= 9.265 \times 111.03 = 1028.7 \angle -72.1^\circ \text{A (symmetrical)}$$

$$= 1028.7 \times \sqrt{3} = 1781.7 \text{A (max rms asymmetrical)}$$

Transient Current:

$$I_f' = \frac{1.0 \angle 0^\circ}{Z_{\text{source}}' + Z_1} = 6.587 \angle -58.7^\circ \text{ pu}$$

$$= 6.587 \times 111.03 = 731.36 \angle -58.7^\circ \text{A (symmetrical)}$$

Steady-State Current:

$$I_f = \frac{1.0 \angle 0^\circ}{Z_{\text{source}} + Z_1} = 2.6073 \angle -62.1^\circ \text{ pu}$$

$$= 2.6073 \times 111.03 = 289.5 \angle -62.1^\circ \text{A (symmetrical)}$$

(e) Time Constants for Three-Phase Faults at Panel Board X

$$X_{\ell 1} \text{ (gen to EPC)} = \frac{0.016 + 0.014}{2} = 0.015$$

$$X_{\ell 1} \text{ (EPC to panel)} = 0.0196$$

$$\Sigma X_{\ell 1} = 0.0346$$

$$r_{\ell 1} \text{ (gen to EPC)} = \frac{0.0136 + 0.0126}{2} = 0.0131$$

$$r_{\ell 1} \text{ (EPC to panel)} = 0.0261$$

$$\Sigma r_{\ell 1} = 0.0392$$

$$r_a = 0.0328 \quad X_2 = 0.134$$

$$T_{ae} = \frac{X_2 + \Sigma X_{\ell 1}}{2\pi f (r_a + \Sigma r_{\ell 1})} = 0.0012 \text{ sec}$$

$$T_{de}'' = T_d'' \frac{r_a}{X_d''} \frac{X_d'' + \Sigma X_{\ell 1}}{(r_a + \Sigma r_{\ell 1})} = 0.0033 \text{ sec}$$

$$T_{de}' = T_d' \frac{X_d}{X_d'} \frac{X_d' + \Sigma X_{\ell 1}}{X_d' + \Sigma X_{\ell 1}} = 0.0351 \text{ sec}$$

(f) Three-Phase Fault Current Summary

The three-phase fault current calculations are summarized in Table 2-4.

TABLE 2-4
THREE-PHASE FAULT CURRENTS

	<u>Time Constant Seconds</u>	<u>Total Current Amperes</u>
Subtransient, I_f'' , symmetrical		1028.7/ <u>-72.1°</u>
Subtransient, rms Asymmetric Peak		1781.7
Subtransient, Inst Asymmetric Peak		2909.2
Time Constant, T_{de}''	0.0033	
DC Decrement, I_{dc}''		1454.6
Time Constant, T_{ae}	0.0012	
Transient, I_f'		731.4/ <u>-58.7°</u>
Time Constant, T_{de}'	0.0351	
Steady State, I_f		289.5/ <u>-62.1°</u>

(g) Source Impedance Calculations for Single-Phase Faults at Panel Board X

Calculate Z_{source}'' , Z_{source}' , and Z_{source} , including positive (Z_1), negative (Z_2), and zero (Z_0) sequence impedances as applicable. Use the equation shown in subparagraph (b) above to calculate the single-phase fault currents $(I_F'', I_F', I_F)_{1\phi}$.

Subtransient Source Impedance, Z_{source}'' :

Generators 1 and 4:

$$Z_{F1}'' = Z_{F4}'' = \Sigma R_F'' + j \Sigma X_F'' = \Sigma R_F + j \Sigma X_F = 0.5333 \text{ } / \underline{69.7^\circ}$$

Generators 2 and 3:

$$Z_{F2}'' = Z_{F3}'' = \Sigma R_F + j \Sigma X_F = 0.5053 \text{ } / \underline{73.0^\circ}$$

$$\begin{aligned} \text{Parallel Source Impedance, } Z_{source}'' &= \frac{Z_{F1}'' \times Z_{F2}''}{Z_{F1}'' + Z_{F2}''} \\ &= Z_{1source}'' + Z_{2source}'' + Z_{osource}'' = 0.2596 \text{ } / \underline{71.4^\circ} \end{aligned}$$

Transient Source Impedance, Z'_{source} :

$$Z'_{f1} = Z'_{f4} = \Sigma R'_f + j \Sigma X'_f = \Sigma R'_f + j \Sigma X'_f = 0.1851 + j 0.5951$$

$$Z'_{f2} = Z'_{f3} = \Sigma R'_f + j \Sigma X'_f = 0.1476 + j 0.5783$$

$$\begin{aligned} \text{Parallel source impedance, } Z'_{\text{source}} &= \frac{Z'_{f1} \times Z'_{f2}}{Z'_{f1} + Z'_{f2}} \\ &= Z'_{1\text{source}} + Z'_{2\text{source}} + Z'_{0\text{source}} = 0.3049 \underline{74.2^\circ} \end{aligned}$$

Steady-State Source Impedance, Z_{source} :

$$Z_{f1} = Z_{f4} = \Sigma R_{f1} + \Sigma X_{f1} = 0.1851 + j 2.1791 = 2.1869 \underline{85.1^\circ}$$

$$Z_{f2} + Z_{f3} = \Sigma R_{f2} + \Sigma X_{f2} = 0.1476 + j 2.1623 = 2.1673 \underline{86.1^\circ}$$

$$\begin{aligned} \text{Parallel source impedance, } Z_{\text{source}} &= \frac{Z_{f1} \times Z_{f2}}{Z_{f1} + Z_{f2}} \\ &= Z_{1\text{source}} + Z_{2\text{source}} + Z_{0\text{source}} = 1.0885 \underline{85.6^\circ} \end{aligned}$$

(h) Fault Current Calculations for Single-Phase Faults at Panel Board X

Z_{1x} , Z_{2x} , and Z_{0x} are feeder sequence impedances shown in subparagraph (d) above.

Subtransient Current:

$$\begin{aligned} I''_F &= \frac{3.0 \underline{0^\circ}}{Z''_{\text{source}} + Z_{1x} + Z_{2x} + Z_{0x}} = 6.7325 \underline{-66.2^\circ} \text{ pu} \\ &= 6.7325 \times 111.03 = 747.5 \underline{-62.2^\circ} \text{ A (symmetrical)} \\ &= 747.5 \times \sqrt{3} \underline{-62.2^\circ} = 1294.7 \text{ A (max rms asymmetrical)} \end{aligned}$$

Transient Current:

$$\begin{aligned} I'_F &= \frac{3.0 \underline{0^\circ}}{Z'_{\text{source}} + Z_{1x} + Z_{2x} + Z_{0x}} = 6.1297 \underline{-68.5^\circ} \text{ pu} \\ &= 6.1297 \times 111.03 = 680.6 \underline{-68.5^\circ} \text{ A (symm)} \end{aligned}$$

Steady-State Current:

$$I_F = \frac{3.0/0^\circ}{Z_{\text{source}} + Z_{1x} + Z_{2x} + Z_{0x}} = 2.3808 \angle -81.8^\circ \text{ pu}$$

$$= 2.3808 \times 111.03 = 264.3 \angle -81.8^\circ \text{ A (symm)}$$

(i) Time Constant Calculations for Single-Phase Fault at Panel Board X

$$T'_{de} = T_{do} \frac{X'_d + X_2 + X_0}{X_d + X_2 + X_0}$$

$$\text{Parallel source } Z' = 0.3049 \angle 74.2^\circ = 0.0830 + j 0.2934$$

Then equivalent $X'_d + X_2 + X_0$ for paralleled sources (two generators to EPC) is 0.2934 pu, and equivalent $r_a + r_2 + r_0$ for paralleled sources is 0.0830 pu.

$$\text{Parallel source } Z = 1.0885 \angle 85.6^\circ = 0.0835 + j 1.083$$

Then equivalent $X_d + X_2 + X_0$ for paralleled sources is 1.0853 pu. Also:

$$\text{Feeder } X_2 + X_0 = 0.0196 + 0.1226 = 0.1422 \text{ pu}$$

$$\text{Feeder } r_2 + r_0 = 0.0261 + 0.0446 = 0.0707 \text{ pu}$$

Then:

$$T'_{de} = 0.0765 \text{ sec}$$

$$Z''_{\text{source}} = 0.2596 \angle 71.4^\circ = 0.0828 + j 0.2460$$

$$X''_d + X_2 + X_0 = 0.2460 \text{ pu}$$

$$r_a + r_2 + r_0 = 0.0828 \text{ pu}$$

$$T''_{de} = T''_d \left\{ \frac{r_a}{X''_d} \right\} \frac{(X''_d + \Sigma X_{\ell 1})}{(r_a + \Sigma r_{\ell 1})} = T''_d \left\{ \frac{r_a}{X''_d} \right\} \frac{X''_d + X_2 + X_0}{r_a + r_2 + r_0}$$

$$T''_{de} = 0.0023 \text{ sec}$$

(j) Single-Phase Fault Current Summary

The single-phase fault current calculations are summarized in Table 2-5.

TABLE 2-5
SINGLE-PHASE FAULT CURRENTS AT SSPC/RCCB PANELS

	<u>Time Constant Seconds</u>	<u>Total Current Amperes</u>
Subtransient, I_f'' , Symmetrical		$747.5 / -66.2^\circ$
Subtransient, rms Asymmetrical Peak		1294.7
Subtransient, Inst. Asymmetrical Peak		2113.9
Time Constant, T_{de}''	0.0023	
DC Decrement, I_{dc}''		1057.0
Time Constant, T_{ae}	0.0002	
Transient, I_f'		$680.6 / -68.5^\circ$
Time Constant, T_{de}'	0.0765	
Steady-State, I_f		$264.3 / -81.8^\circ$

(k) Panel Board Fault Current Curves

The fault currents summarized in Tables 2-4 and 2-5 are shown graphically as functions of time in Figure 2-9. These curves are for the hypothetical panel board X with a 100 ft. feeder of 3 AN-4 conductors. The curves for other panel boards with feeders of less than 100 feet length or of conductor sizes larger than AN-4 will have characteristics between those of Figures 2-8 and 2-9.

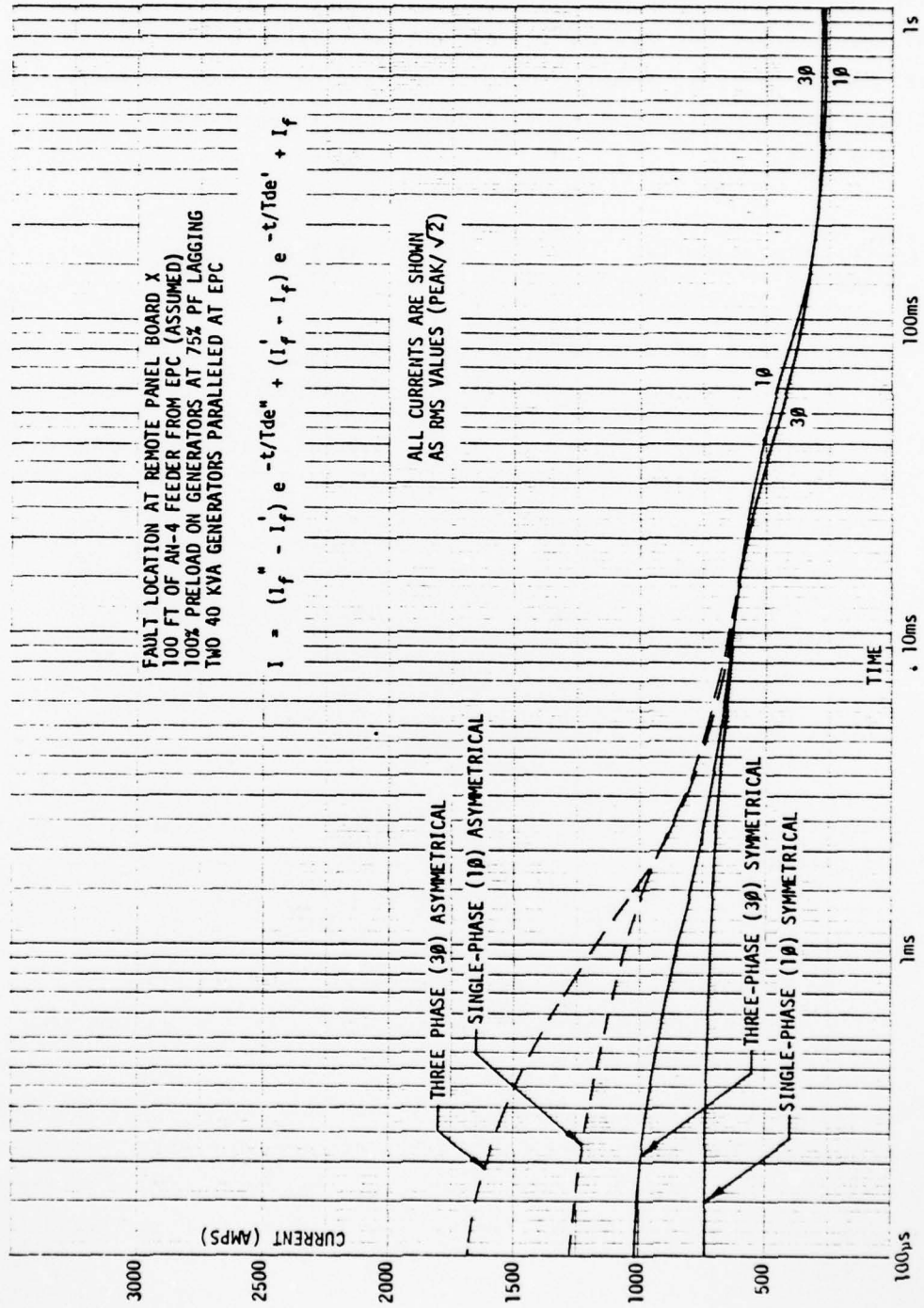

Figure 2-9. Panel Board X Fault Current Characteristics

2.4.10 Current Rate-of-Change, di/dt

For SSPC design purposes, the maximum rate of current change is needed. The maximum theoretical rate of current change, di/dt, will occur at the initial moment of fault with the condition yielding maximum asymmetry, (i.e. fault occurring at maximum current in one of the three-phases).

$$\text{Then: } i = I_m \sin \omega t$$

$$\therefore \left(\frac{di}{dt} \right)_{\max} = I_m \omega \cos \omega t \Big|_{t=0} = I_m \omega = 800 \pi I_m$$

The maximum instantaneous current, $I_m = 2\sqrt{2} I_a''$

Location	Fault Type	Symmetrical Current I_a''	Theoretical Asymm. Maximum Instant. Current	Theoretical Asymm Maximum di/dt, A/ μ s
EPC	Three Phase	1330.7	3763.2	9.458
EPC	Single-Phase	1497.2	4234.1	10.641
Panel X	Three Phase	1028.7	2909.2	7.312
Panel X	Single-Phase	747.5	2113.9	5.313

For the first half-cycle $\frac{di}{dt} = \left(\frac{di}{dt} \right)_{\max} \cos \omega t$

Thereafter, the current rate-of-change will decay in strict accordance with the fault current:

$$\frac{di}{dt} = 800 \pi \sqrt{2} I_{\text{rms}} \cos \omega t$$

Where: I_{rms} = rms current for each cycle measured at the desired time, t

The first few cycles of the maximum three-phase fault current and the envelope of the maximum single-phase fault current are plotted in Figure 2-10 for faults at either the left EPC or the right EPC. Faults occurring at the remote panel boards will be proportionally less severe, as described in Section 2.4.9.

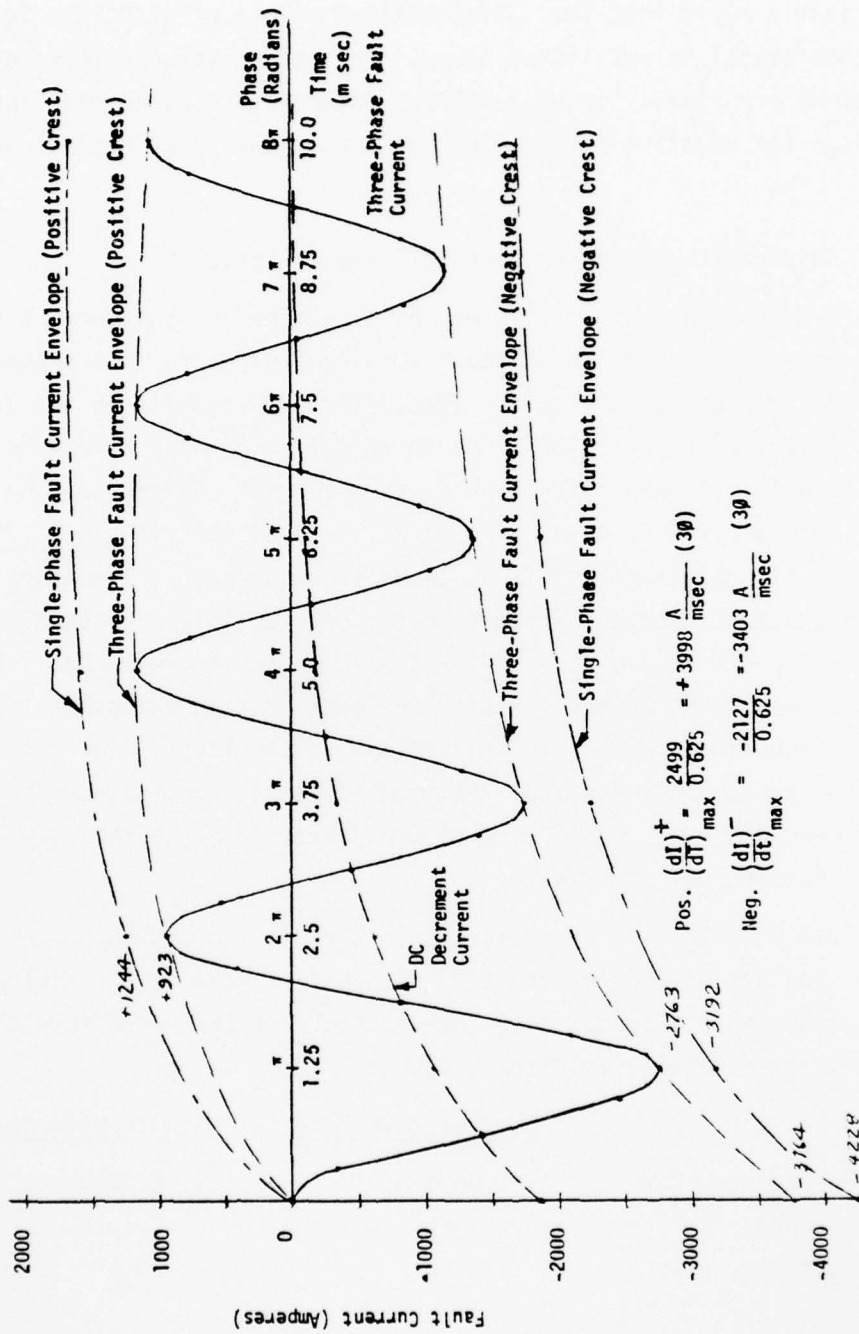

$$\text{Pos. } \left(\frac{di}{dt}\right)_{\max}^+ = \frac{2499}{0.625} = +3998 \frac{\text{A}}{\text{msec}} \quad (3\theta)$$

$$\text{Neg. } \left(\frac{di}{dt}\right)_{\max}^- = \frac{-2127}{0.625} = -3403 \frac{\text{A}}{\text{msec}} \quad (3\theta)$$

Figure 2-10. Fault Current Envelope for Electrical Power Center

The rates of decay of the dc decrement current and the subtransient current are sufficiently rapid that the actual maximum values of di/dt are less than the theoretical values listed above. The actual values, therefore, are determined graphically to be $3.998A/\mu s$ for positive rates of change and $3.403A/\mu s$ for negative rates of change during the first cycle (worst case).

2.4.11 Aircraft Load Branch Circuit Characteristics

The aircraft load branch circuit sizes are determined by the current rating required by the load and by the allowable voltage drop from the protective device (SSPC, or RCCB, or CB) to the load, whichever results in the larger wire size. Loads supplied by SSPCs up to 10A will normally have wire sizes from AN18 to AN14. A wire size of AN20 has a current capacity rating of 7.5A and a single-wire impedance of $10.25 + j 0.304$ ohms ($10.25 \angle 1.7^\circ$ ohms) per 1000 feet circuit length; this AN-20 wire would present a voltage drop of 2.6 volt at the continuous current rating of 7.5A in a wire bundle. Allocations of 3 volts were made to the 115/AC branch circuits and 1.5 volts were made to the 28 VDC branch circuits for model design purposes. This wire size is therefore acceptable and typical for AC loads. The same load in the 28 VDC system will require a maximum impedance (resistance for dc) of 5.7 ohm per 1000 feet. An AN16 wire would satisfy this load with its 4.95 ohm resistance per 1000 feet.

A typical load circuit used for load branch circuit simulation in the laboratory consists of 34 feet of AN-20 wire pair spaced at 0.5 inch and laid upon an aluminum ground plane. Measurements of the parameters of this circuit gave the following results at 400 Hz,

	<u>Loop Circuit Data</u>	<u>Single Wire Data</u>
AC Resistance, R_{ac}	0.65 ohm	0.325 ohm
Inductance, L	$2.2 \mu H$	$1.1 \mu H$
Capacitance, C	$140 \mu F$	$70 \mu F$

2.5 E-MUX SYSTEM

The E-MUX system architecture consists of applications of the appropriate quantities of system elements (as shown in Figure 2-11) to meet the required redundancy level of the subsystems served. These elements are:

- 1) Digital computers (two are required per aircraftside, left and right).
- 2) Digital transmission line (each system is dual redundant).
- 3) Multiplex terminal units MTU's (these provide data bus interfaces with SSPC's).
- 4) Solid state power controllers (these provide the required power distribution control, subsystem protection, and circuit status signals).
- 5) Control/display center (this provides flight crew interactions with E-MUX functions).

2.5.1 E-MUX Digital Computers

The digital computers perform the functions of overall E-MUX system management and data/signal distribution to those subsystems subscribing to the E-MUX service. These computers are located in the Avionics bay of the C-15 aircraft where maintenance and physical isolation can be provided. The design factors considered in the selection of a suitable digital computer concept are performance margins, minimal lifecycle cost of ownership, small size (volume and dimensions) light weight, low power consumption, environmental ruggedness (thermal, vibration, shock, moisture and particulate tolerances), high reliability and maintainability. In addition, the digital computer must operate without degradation in a highly inhospitable electromagnetic environment, including EMP tolerance/hardening for military applications.

Two extreme architectural approaches are possible to satisfy the total aircraft computational requirements:

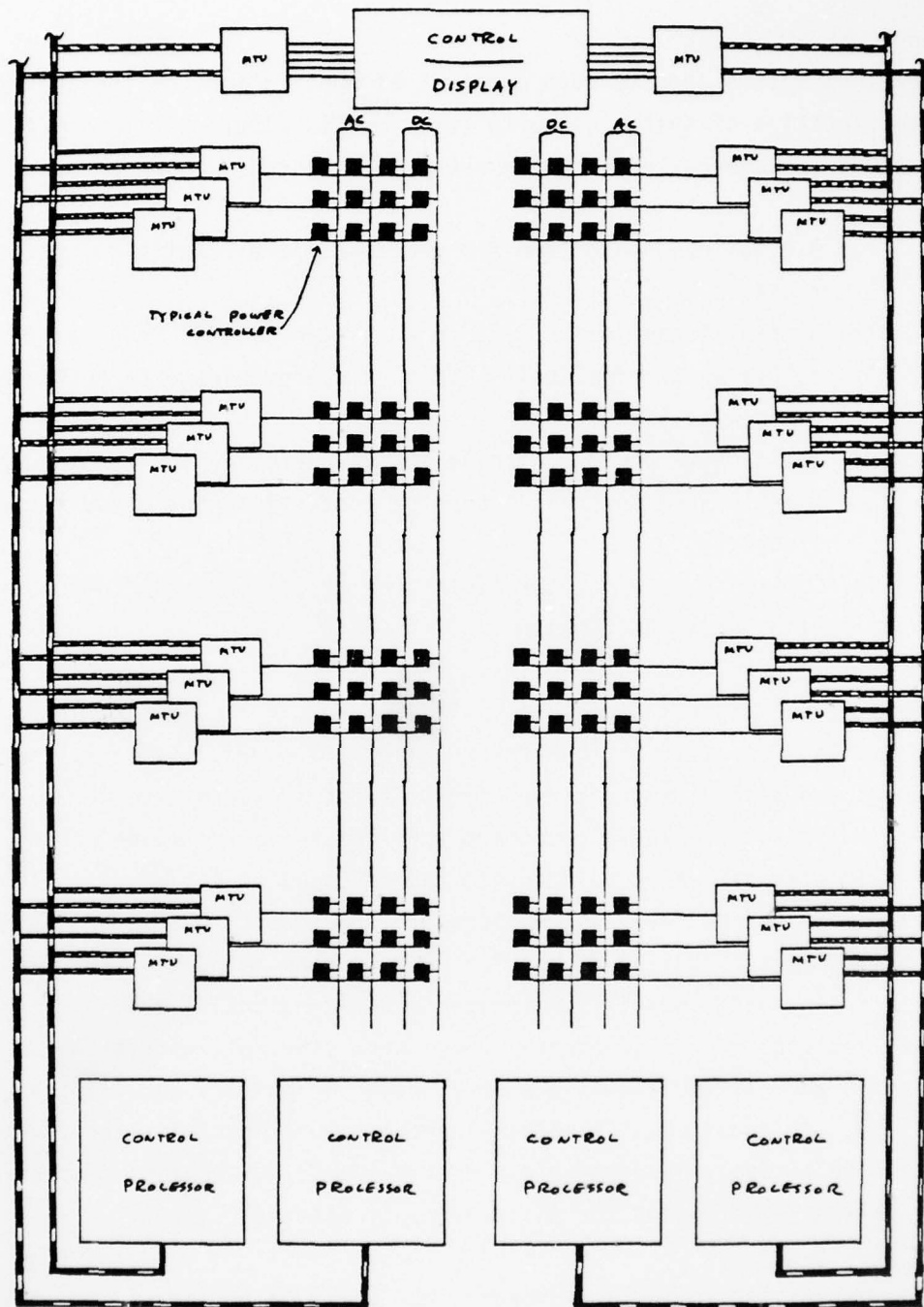

Figure 2-11. Proposed E-MUX Concept

AD-A063 405

TELEPHONICS CORP HUNTINGTON N Y
ADVANCED SOLID STATE POWER CONTROLLER DEVELOPMENT. PHASE I. STU--ETC(U)
SEP 78 R J EDWARDS

F/G 10/2

F33615-77-C-2017

AFAPL-TR-78-55

NL

UNCLASSIFIED

3 of 5

AD A063405

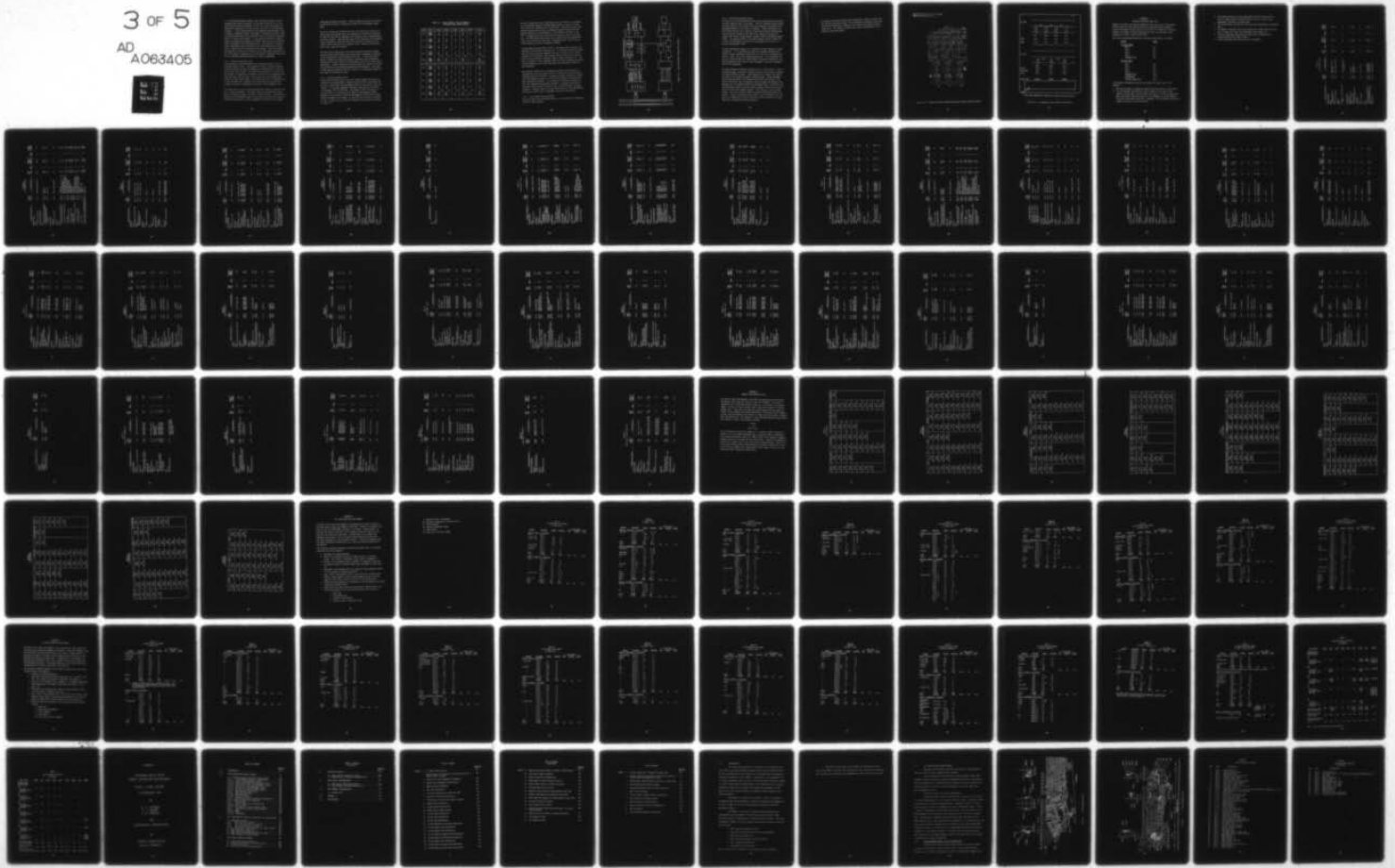

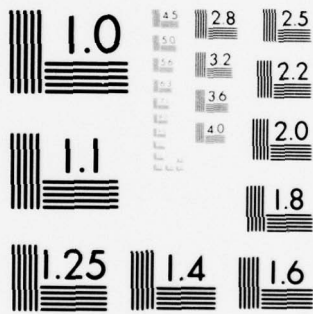

MICROCOPY RESOLUTION TEST CHART
NATIONAL BUREAU OF STANDARDS-1963-A

1) A centralized computing center sized to meet and handle all data processing and control functions for the entire aircraft, or 2) a decentralized/partitioned approach in which the aircraft subsystems are selectively integrated in various groups, each with its own dedicated processor. A major consideration of the decentralized approach is that it permits independent design, development, integration and test, thereby minimizing technical risks associated with the interactive characteristics of larger scale systems. It also permits the use of a greater number of standardized computers of reduced capability, which minimizes design, development, and replacement costs. The maturing of microprocessor technology enhances the probability that decentralized processing will become the most attractive E-MUX concept. Under the present configuration, and due to its interfacing and functional characteristics, the E-MUX concept is proposed to be a selectively integrated system with its own dedicated Computer/Processors as central components.

2.5.2 Digital Transmission Line

The transmission line interconnects the computer/processor with the multiplex terminal units. The transmission line is routed to prevent system malfunction due to the severance or contamination of single cables or cable routing paths. The transmission medium for the E-MUX system concept, as presently configured, consists of two independent data buses per side, left and right, which handle the MIL-STD-1553A type (1 Mbit) digital signal format. Each (open loop) bus is terminated into its own characteristic impedance at both ends and has provisions for branches or stubs to interconnect the various E-MUX component units.

The closed loop bus, as an alternate termination method to the open loop bus, is being considered. The closed loop bus would provide an extra level of protection against localized, singular failures. Additional bus monitoring and maintenance would be required to identify and to correct failures as they occur, so that subsequent failures would not produce

compounded maintenance problems. Further trade-off studies are required to determine the best bus termination method for the transport system model.

The use of twisted and shielded wire pairs for E-MUX data buses has recently been re-evaluated, due to the upsurge of fibre optics technology. A number of fibre optics components and prototype working demonstrations have been examined. Some peculiarities of this technology are noteworthy: signal transmission continuity even after unmating of connector pairs (within certain proximity and alignment limits), immunity to vibration, stray light, shock and humidity.

The fibre optics technology as the E-MUX transmission medium, however, provides only marginal weight and volume savings advantages as compared to the conventional twisted shielded wire pairs. It does provide different, although not necessarily better, mechanical and environmental characteristics which might be of significant value in the E-MUX concept application. Further industry-wide trade studies will resolve this issue of applicability to the different operational environments. The transmission approach identified for this study will be twisted-shielded wire pair data bus transmission lines.

2.5.3 Multiplex Terminal Units

The multiplex terminal units, which are located adjacent to centers of electrical load concentration, interface with the solid state power controllers to distribute E-MUX commanded signals to the various using subsystems. E-MUX system component interface signal formats are defined in accordance with MIL-STD-1553A. The number of MTU's utilized in a given aircraft is a function of the number of input/output signals assigned to be handled by E-MUX and the geometric distribution of those signals throughout the airframe. In the case of this study, 35 terminals will be used with 16 on the left side and 19 on the right, as shown in Table 2-6.

TABLE 2-6. E-MUX TERMINAL (MTU) ASSIGNMENTS
SSPC/RCCB PANEL BOARD LOCATION

SYSTEM	UNITS	STA300	STA400	STA600	STA800	STA1000	TOTALS
AC-1	SSPC	7	11	5	15	5	43
	SPARE	5	5	3	5	3	21
	TOTAL	12	16	8	20	8	64
DC-1	SSPC	12	14	0	18	2	46
	SPARE	4	6	0	6	2	18
	TOTAL	16	20	0	24	4	64
AC-2	SSPC	9	17	0	8	0	33
	SPARE	4	7	0	4	0	15
	TOTAL	12	24	0	12	0	48
DC-2	SSPC	11	9	0	17	2	39
	SPARE	5	3	0	7	2	17
	TOTAL	16	12	0	24	4	56
TOTAL	SSPC	42	51	5	58	9	161
	SPARE	18	21	3	22	7	71
	TOTAL	60 4	72 5	8 1	80 5	16 1	232 16
AC-3	SSPC	10	23	0	12	0	45
	SPARE	6	5	0	4	0	15
	TOTAL	16	28	0	16	0	60
DC-3	SSPC	9	18	0	17	2	46
	SPARE	3	6	0	7	2	18
	TOTAL	12	24	0	24	4	64
AC-4	SSPC	8	10	7	14	7	46
	SPARE	4	6	5	6	5	26
	TOTAL	12	16	12	20	12	72
DC-4	SSPC	8	15	0	18	2	43
	SPARE	4	5	0	6	2	17
	TOTAL	12	20	0	24	4	60
TOTAL	SSPC	35	67	7	61	11	180
	SPARE	17	21	5	23	9	76
	TOTAL	52 4	88 6	12 1	84 6	20 2	256 19

The bus (transmission line) interface of the E-MUX MTU'(s) is performed by the Multiplex Terminal Interface Module (MTIM), as shown in Figure 2-12, which fully complies with MIL-STD-1553A. The serial digital data stream received from the bus is converted to parallel format for subsequent processing and conditioning in the remaining circuits of the MTU. The opposite process takes place with signals going to the data bus. The MTIM places these signals upon command from the Computer/Processor, and performs the functions of synchronization, bit and parity error checking, and also of message validation.

The Subsystem Interface Module (SSIM) is the other major functional sub-assembly of the Multiplex Terminal Unit. It provides input/output interface with the utilization equipment as shown in Figure 2-12, including conversion of the parallel data received from the MTIM to the requirements of each individual subsystem, sensor, power controller, etc. The SSIM is designed in dual redundant stages to provide redundant data handling requirements to the level demanded by the functional criteria of each subsystem.

The Multiplex Terminal Unit continuously performs cross-checking of corresponding input and output signals to assure that the incoming and outgoing signals are identical in content, although different in format. This cross-checking function is done for both upstream and downstream data transmission patterns. The separation of incoming subsystem signals into redundant data-handling channels is achieved by physically connecting those signals to specific pins in the subsystems interface connector. Periodic checking of such data handling is also performed to validate the proper level of redundancy chosen for each signal.

2.5.4 Solid State Power Controllers

The Solid State Power Controller design is to be provided by Telephonics under this USAF contract.

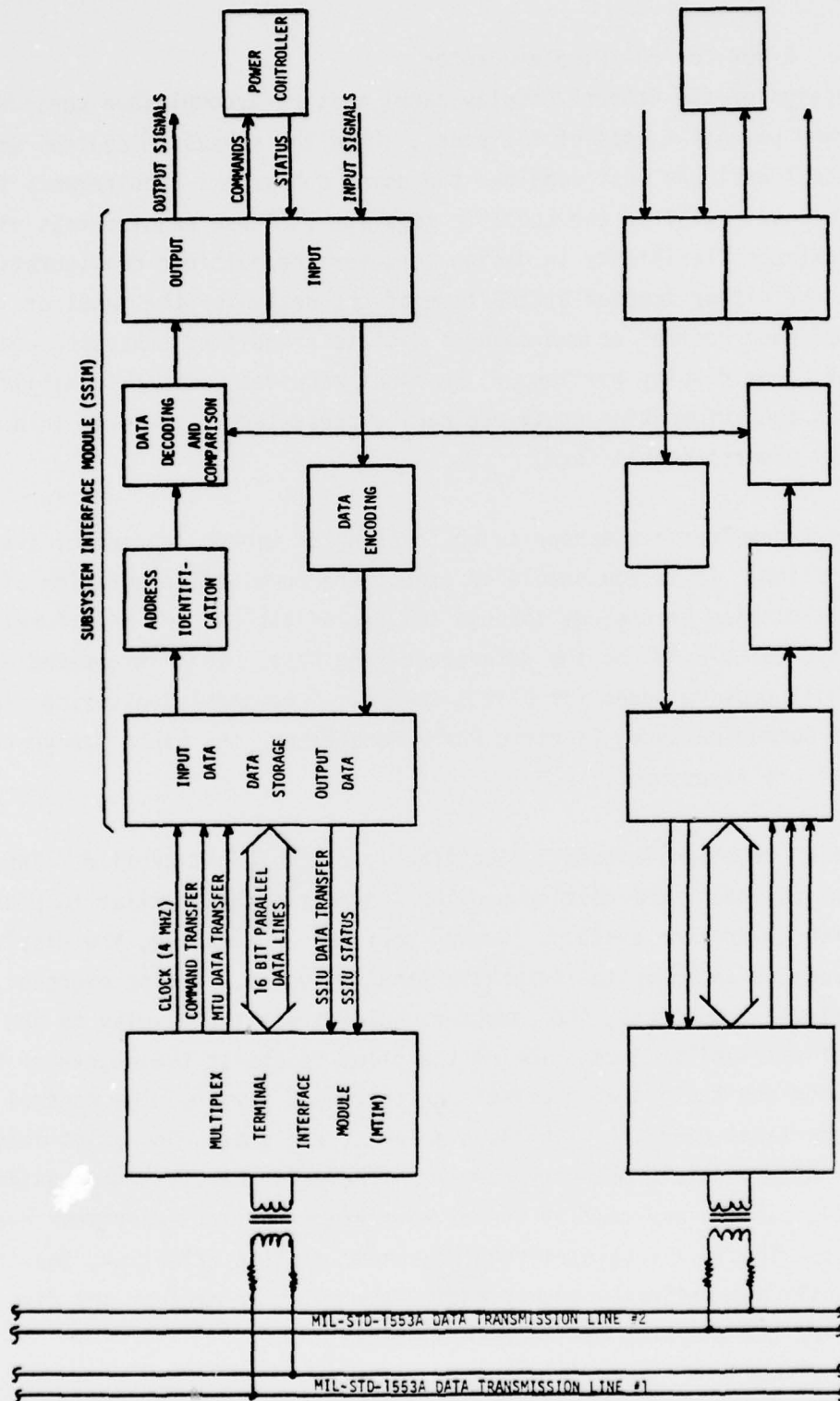

Figure 2-12. Typical Multiplex Terminal Unit (MTU)

2.5.5 E-MUX Control/Display Center

The design of the Control/Display panel must be accomplished considering the many potential uses of the panel. From the subsystem control aspect, the panel designer must consider the using subsystems requirements for management/control of the specific subsystem. These requirements dictate extreme flexibility in design to cover the multiple configurations which are either imposed at the time of the design of the panel or created when control scheme changes dictate a modified subsystem control format. The display portion of the panel requires similar flexibility so that the information contained can be presented to the crew in a quickly understandable form.

Aircraft developments appear to be focusing on higher degrees of system integration. It is reasonable to expect the complete integration of cockpit display technology through the use of the CRT and multifunction display, using E-MUX as the data/processing base. This integrated display will provide modes for Flight Control, Subsystems Monitoring, Integrated Communications, Electric Power Management, and Fault Management and Failure Assessment.

The pilot receives information pertinent to his flight profile. Thus in navigation modes, the display provides navigation aid similar to present day area navigation systems. During approach and landing, the display functions as an autopilot/Automatic landing system. During emergency and failure conditions, the computer would direct the display to the area of difficulty, thus allowing the pilot to assess the degree of the emergency and its probable effects on continued flight. The control system interfaces directly with the display, thereby allowing pilot interaction with the main computer complex. The pilot may, via the system control, call up any display format to perform routine subsystems evaluations. Should a subsystem require specific pilot attention, the computer will automatically either notify the pilot or present the display featuring the subsystem malfunction/anomaly.

An example of existing display panel technology is shown in Figure 2-13 for the DC-10 electrical panel. The information contained on that panel could quite effectively be combined into the CRT type display shown in Figure 2-14. This type of display would reduce the complexity of the panel and save panel space.

THIS PAGE IS BEST QUALITY PRACTICABLE
FROM COPY FURNISHED TO DDC

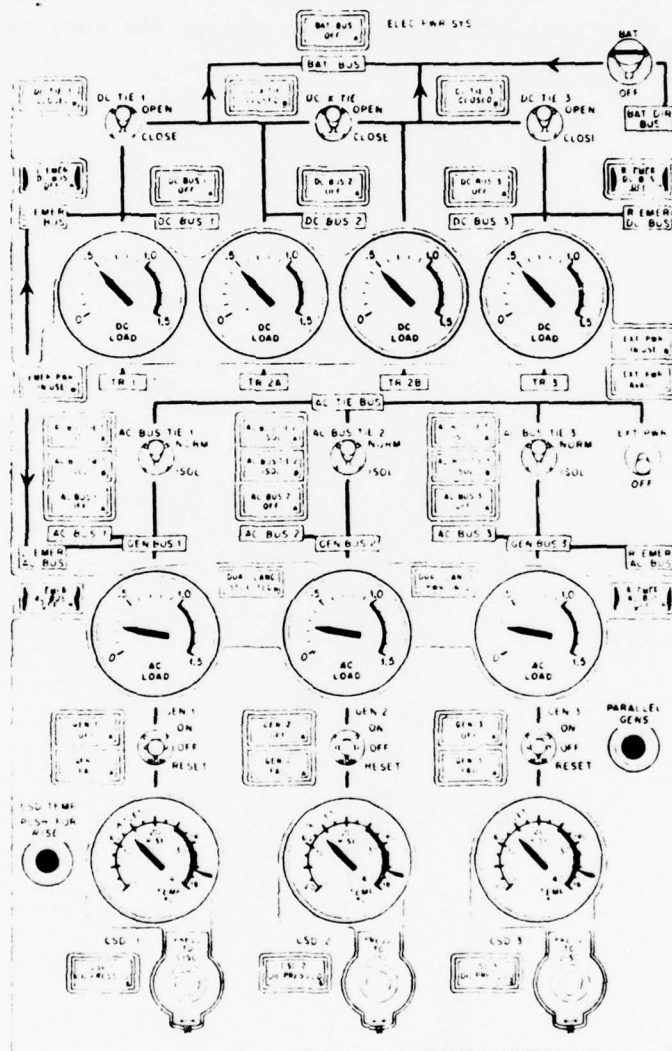
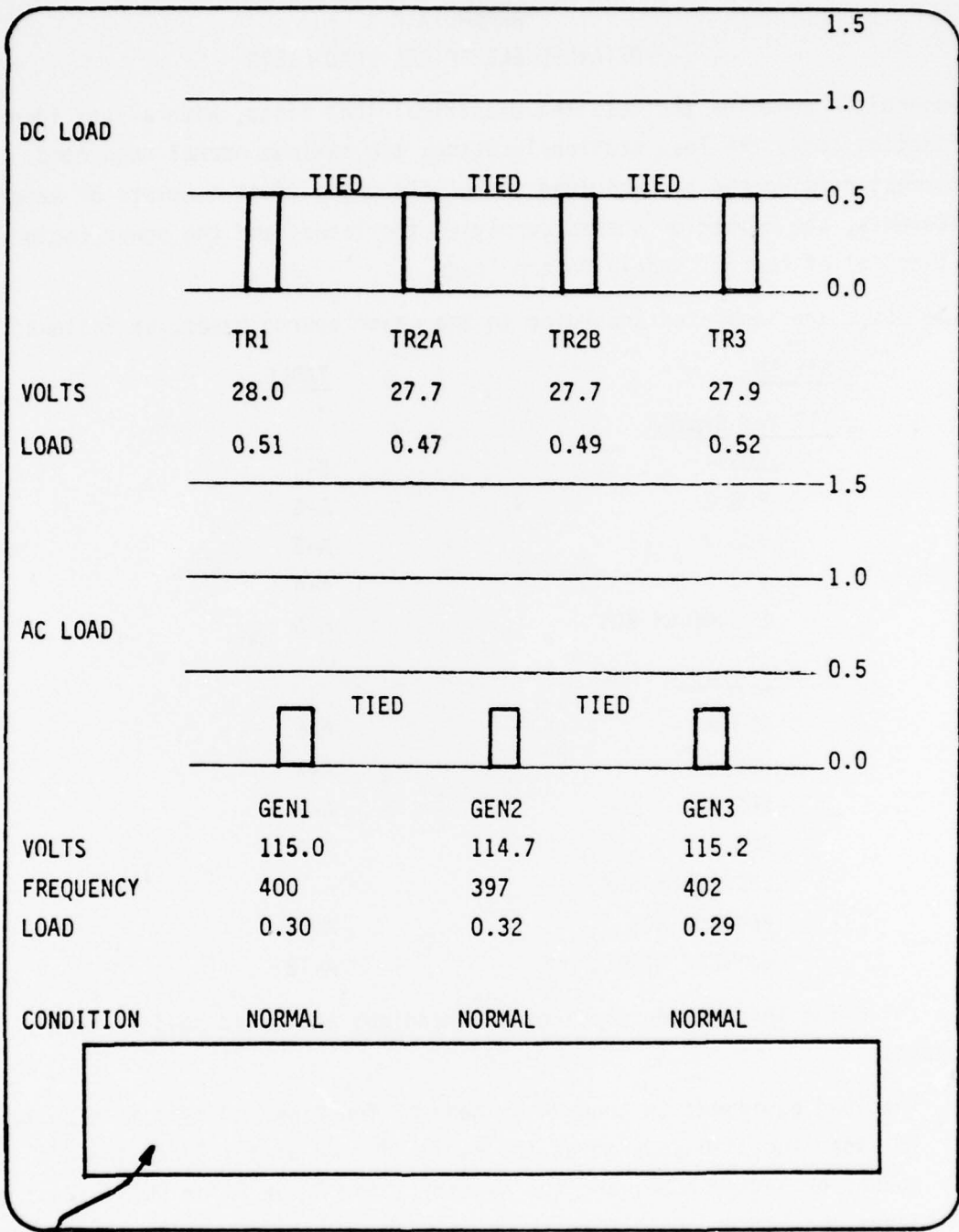

Figure 2-13. Typical Aircraft System Display Panel (DC-10 Electric Panel)



THIS AREA RESERVED FOR DISPLAY OF SYSTEM FAULTS AND STATUS

Figure 2-14. Integrated Electric Power Display Panel

APPENDIX A
DETAILED ELECTRICAL LOAD LISTS

Appendix A contains the detailed electrical load lists, with a load identification code, the load station/location, the maximum normal connected current requirement of each load, or of its units if it consists of several elements, the number of phases supplying the loads, and the power factor (lagging) of current supply to the loads.

The lists are separated according to the major source buses, as follows:

<u>SYSTEM</u>	<u>TABLE</u>
<u>115 Vac System</u>	
BUS 1	A-1
BUS 2	A-2
BUS 3	A-3
BUS 4	A-4
EMERGENCY BUS	A-5
<u>28 Vdc System</u>	
BUS 1	A-6
BUS 2	A-7
BUS 3	A-8
BUS 4	A-9
EMERGENCY BUS	A-10
BATTERY BUS	A-11
BATTERY DIRECT BUS	A-12

The following information explains the headings and codes used in this Appendix.

1. The load equipment is grouped by general function and type in each table.
2. The load location code gives the serial number of the load, the bus number or letter code, and the system (A for AC or D for DC); except emergency and battery buses are shown as E for emergency, as BB for battery bus and BD for battery direct bus. (Example: 23-2-A indicates load serial number 23 and Bus 2 on the AC system.)

3. The Station/Location gives the approximate aircraft frame station (X-axis) in inches and/or a physical location, such as a panel, rack, compartment, wing area, or engine area.
4. The current values are given for each unit that constitutes an identified load.
5. The number of identical units which constitute a single controlled load (e.g. 4 lamps in a circuit are indicated by the number, 4).
6. The total connected load current is shown which is controlled by a single control device (SSPC or RCCB).
7. Phase and percent power factor are self explanatory.

TABLE A-1
115 VAC SYSTEM - BUS 1

EQUIPMENT DESCRIPTION	LOAD LOCATION CODE	STATION/LOCATION	AMPS PER UNIT	UNITS	CONNECTED LOAD (AMPERES)	PHASES	PERCENT POWER FACTOR
<u>AIR CONDITIONING</u>							
<u>MOTORS</u>							
Avionics Rack Fan #1	1-1-A	425/L Avionics Rack	7.3	1	7.3	3	75
EPC Cooling Fan	2-1-A	375/L EPC	1.6	1	1.6	1	78
<u>UNITS</u>							
Left Fan and Venturi	4-1-A	675/L Landing Gear Pod	1.6	1	1.6	1	78
<u>AIRDROP</u>							
<u>UNITS</u>							
L Static Line Retriever Winch Power	5-1-A	435/L Aircraft Wall at Aircraft C _L	13.6	1	13.6	3	65
<u>ELECTRICAL POWER</u>							
<u>TRANSFORMERS</u>							
28 Vac Transformer	7-1-A	375/L EPC	0.8	1	0.8	1	85
<u>UNITS</u>							
Battery Charger	8-1-A	370/Lower EPC, L	0.9	1	0.9	3	70
Transformer-Rectifier #1	9-1-A	375/L EPC	4.8	1	4.8	3	95
<u>FURNISHINGS</u>							
<u>UNITS</u>							
Hot Cup Assembly	10-1-A	325/L of Pilot	8.7	1	8.7	1	100
<u>FUEL</u>							
<u>MOTORS</u>							
Tank #1 Aft Fuel Boost Pump	12-1-A	L Wing Outboard	7.0	1	7.0	3	74
Fuel Transfer Pump #1	13-1-A	L Wing Outboard	7.0	1	7.0	3	74
Tank #2 Fwd Fuel Boost Pump	14-1-A	L Wing Inboard	7.0	1	7.0	3	74
<u>UNITS</u>							
Fuel Heat #1	15-1-A	L Wing Outboard	1.2	1	1.2	1	80

TABLE A-1
(Continued)
115 VAC SYSTEM - BUS 1

EQUIPMENT DESCRIPTION	LOAD LOCATION CODE	STATION/LOCATION	AMPS PER UNIT	UNITS	CONNECTED LOAD (AMPERES)	PHASES	PERCENT POWER FACTOR
<u>HYDRAULIC POWER</u>							
<u>MOTORS</u>							
Aux Hydraulic Pump #3	16-1-A	730/R Landing Gear Pod	65.0	1	65.0	3	75
<u>ICE AND RAIN PROTECTION</u>							
<u>UNITS</u>							
L Windshield Anti-Ice Controller	17-1-A	375/L EPC	12.0	1	12.0	1	90
L Windshield Defog Controller	18-1-A	375/L EPC	6.6	1	6.6	1	90
L Clearview Window Defog Controller	19-1-A	375/L EPC	6.6	1	6.6	1	90
<u>LANDING GEAR</u>							
<u>SOLENOIDS</u>							
L Parking Brake Valve	20-1-A	850/L Landing Gear Pod	3.0	1	3.0	1	70
<u>LIGHTING</u>							
<u>UNITS</u>							
L Wing Tip Anti-Collision Light	21-1-A	L Wing Tip	0.7	1	0.7	1	100
L Cargo Loading Area Lights	22-1-A	1135, 1250 & 1355 at Z = +30 L Cargo Loading Area	1.8	3	5.4	1	100
L Cargo Area Fluorescent Lights	23-1-A	570, 662, 880, 970, 1062 & 1160 Left Cargo Area Ceiling	1.5	6	9.0	1	58
L Taxi Light	24-1-A	725 L Landing Gear Door	7.8	1	7.8	1	100
L Wing Formation Lights	25-1-A	L Wing Tip & L Wing Trailing Edge Fillet	0.43	2	0.87	1	100
L Macelle Scanning Light	26-1-A	375/Fuseilage C _L	0.9	1	0.9	1	100
L Position Light	27-1-A	L Wing Tip	0.87	1	0.87	1	100
L Landing Light	28-1-A	L Wing Tip	5.2	1	5.2	1	100
L Cargo Area Incandescent Lights	29-1-A	570, 662, 880, 970, 1062, 1160 L Cargo Area Ceiling	1.3	6	7.8	1	100
L Cargo Area Curb Lights	30-1-A	L Cargo Area Curb Fwd & Aft	4.8	1	4.8	1	100
L Staging Area Lights	31-1-A	Under Side of L Horizontal Stabilizer	2.6	2	5.2	1	100
L Ramp Lights	32-1-A	L 980 & Z = +55 L 980 & Z = -25	0.8	2	1.7	1	100
Pilots Instr Pan Lighting Controller	33-1-A	L 273	0.87	1	0.87	1	100
Center Instr Pan Lighting Controller	34-1-A	Center 273	0.87	1	0.87	1	100

TABLE A-1
(Continued)
115 VAC SYSTEM - BUS 1

EQUIPMENT DESCRIPTION	LOAD LOCATION CODE	STATION/LOCATION	AMPS PER UNIT	UNITS	CONNECTED LOAD (AMPERES)	PHASES	PERCENT POWER FACTOR
<u>NAVIGATION</u>							
<u>PANELS</u>							
L Integrated Nav Control Panel	36-1-A	325/Pedestal L Side	1.0	1	1.0	1	90
<u>UNITS</u>							
Omega Attitude Monitoring and Switching Unit	37-1-A	425/L Avionics Rack	0.9	1	0.9	1	95
	38-1-A	425/L Avionics Rack	0.9	1	0.9	1	95
<u>PNEUMATIC</u>							
<u>UNITS</u>							
Pneumatic Sys Controller #1	39-1-A	375/L EPC	0.6	1	0.6	1	95
<u>AIR</u>							
<u>UNITS</u>							
Engine Anti-Ice	41-1-A	Engine #3	1.2	1	1.2	1	80
<u>ENGINE INDICATING</u>							
<u>INDICATORS</u>							
EPR/RAT/EPR	42-1-A	275/Center Instr Panel	0.3	1	0.3	1	70
<u>OIL</u>							
<u>INDICATORS</u>							
Engine Oil Pressure #1 & #2	45-1-A	275/Center Instr Panel	0.1	1	0.2	1	90
	46-1-A	275/Center Instr Panel	0.1	1	0.2	1	90

TABLE A-2

115 VAC SYSTEM - BUS 2

<u>EQUIPMENT DESCRIPTION</u>	<u>LOAD LOCATION CODE</u>	<u>STATION/LOCATION</u>	<u>AMPS PER UNIT</u>	<u>UNITS</u>	<u>CONNECTED LOAD (AMPERES)</u>	<u>PHASES</u>	<u>PERCENT POWER FACTOR</u>
<u>AIR CONDITIONING</u>							
<u>MOTORS</u>							
Avionics Rack Fan #2	1-2-A	425/L Avionics Rack	7.3	1	7.3	3	75
<u>AUTO FLIGHT</u>							
<u>INDICATORS</u>							
Thrust Rating Indicator	2-2-A	275/Center Instr Panel	0.3	1	0.3	1	90
<u>UNITS</u>							
L VAM Computer	3-2-A	425/L Avionics Rack	1.3	1	1.3	1	90
AT/SC Computer #2	4-2-A	425/L Avionics Rack	0.77	1	0.77	1	99
Flt Gdnc Pitch Computer #1	5-2-A	425/L Avionics Rack	2.0	1	2.0	1	90
Flt Gdnc Roll Computer #1	6-2-A	425/L Avionics Rack	1.8	1	1.8	1	80
<u>COMMUNICATIONS</u>							
<u>UNITS</u>							
Airborne Structural Integrity	8-2-A	L Avionics Rack	0.9	1	0.9	1	85
<u>ELECTRICAL POWER</u>							
<u>TRANSFORMERS</u>							
26 Vac Transformer	13-2-A	375/L EPC	0.8	1	0.8	1	85
Transformer-Rectifier #2	14-2-A	375/L EPC	5.5	1	5.5	3	95
<u>FLIGHT CONTROLS</u>							
<u>UNITS</u>							
L E/R Ratio Sys Programmer	15-2-A	425/L Avionics Rack	0.7	1	0.7	1	85
L Auto Stat Actuator	16-2-A	L Wing Leading Edge	3.3	1	3.3	1	70
<u>FUEL</u>							
<u>INDICATORS</u>							
Fuel Temp Selector/Indicator	18-2-A	275/Center Instr Panel	0.1	1	0.1	1	95
<u>MOTORS</u>							
Center Tank Aft Fuel Boost Pump	19-2-A	Center Wing Box Tank	7.0	1	7.0	3	74
Tank #1 Fwd Fuel Boost Pump	20-2-A	L Wing Outboard	7.0	1	7.0	3	74
Tank #2 Aft Fuel Boost Pump	21-2-A	L Wing Outboard	7.0	1	7.0	3	74
Fuel Transfer Pump #2	22-2-A	L Wing Inboard	7.0	1	7.0	3	74

TABLE A-2
(Continued)
115 VAC SYSTEM - BUS 2

EQUIPMENT DESCRIPTION	LOAD LOCATION CODE	STATION/LOCATION	AMPS PER UNIT	UNITS	CONNECTED LOAD (AMPERES)	PHASES	PERCENT POWER FACTOR
<u>UNITS</u>							
Fuel Heat #2	23-2-A	L Wing Inboard	1.2	1	1.2	1	80
<u>HYDRAULIC POWER</u>							
<u>MOTORS</u>							
Aux Hydraulic Pump #4	24-2-A	730/L Landing Gear Pod	65.0	1	65.0	3	75
<u>ICE AND RAIN PROTECTION</u>							
<u>UNITS</u>							
L Eyebrow Window Defog Cont	25-2-A	375/L EPC	6.6	1	6.6	1	90
L Aft Window Defog Cont	26-2-A	375/L EPC	6.6	1	6.6	1	90
L Downview Window Defog Cont	27-2-A	375/L EPC	6.6	1	6.6	1	90
L Angle of Attack Sensor Heat	29-2-A	361/L & Z = -32	2.9	1	2.9	1	100
L Alternate Static Port Heat	30-2-A	343/L & Z = -53	3.8	1	3.8	1	90
<u>FURNISHINGS</u>							
<u>MOTORS</u>							
Pilot's Seat (Vert Motor)	31-2-A	325/Pilot's Seat	1.1	1	1.1	3	78
Pilot's Seat (Hor. Motor)	32-2-A	325/Pilot's Seat	1.1	1	1.1	3	80
<u>NAVIGATION</u>							
<u>INDICATORS</u>							
Pilot Vertical Speed Indicator	33-2-A	275/Pilot's L Instr Panel	0.1	1	0.1	1	90
<u>UNITS</u>							
L Navigation Computer	35-2-A	425/L Avionics Rack	1.9	1	1.9	1	90
L Nav Control/Display Unit	38-2-A	325/Pedestal L Side	1.3	1	1.3	1	90
TACAN	39-2-A	425/L Avionics Rack	2.0	1	2.0	1	95
GPS Receiver/Processor	40-2-A	425/L Avionics Rack	2.6	1	2.6	1	90
Central Air Data Computer #2	41-2-A	425/L Avionics Rack	1.2	1	1.2	1	77
<u>PNEUMATIC</u>							
<u>UNITS</u>							
Pneumatic Sys Controller #2	42-2-A	375/L EPC	0.6	1	0.6	1	95

TABLE A-2
 (Continued)
 115 VAC SYSTEM - BUS 2

<u>EQUIPMENT DESCRIPTION</u>	<u>LOAD LOCATION CODE</u>	<u>STATION/LOCATION</u>	<u>AMPS PER UNIT</u>	<u>UNITS</u>	<u>CONNECTED LOAD (AMPERES)</u>	<u>PHASES</u>	<u>PERCENT POWER FACTOR</u>
AIR UNITS Engine Anti-Ice #4	44-2-A	Engine #4	1.2	1	1.2	1	80

TABLE A-3
115 VAC SYSTEM - BUS 3

EQUIPMENT DESCRIPTION	LOAD LOCATION CODE	STATION/LOCATION	AMPS PER UNIT	UNITS	CONNECTED LOAD (AMPERES)	PHASES	PERCENT POWER FACTOR
<u>AIR CONDITIONING</u>							
<u>MOTORS</u>							
Under Floor Fan #2	1-3-A	475/Under R Avionics Rack	7.3	1	7.3	3	75
<u>AUTO FLIGHT</u>							
<u>INDICATORS</u>							
Thrust Rating Indicator	2-3-A	275/Center Instr Panel	0.3	1	0.3	1	90
<u>UNITS</u>							
R VAM Computer	3-3-A	425/R Avionics Rack	1.3	1	1.3	1	90
AT/SC Computer #2	4-3-A	425/R Avionics Rack	0.77	1	0.77	1	99
Flt Gdnc Pitch Computer #2	5-3-A	425/R Avionics Rack	2.0	1	2.0	1	90
Flt Gdnc Roll Computer #2	6-3-A	425/R Avionics Rack	1.8	1	1.8	1	80
Radar Altitude Receiver/Transmitter	8-3-A	760/C Under Floor	0.7	1	0.7	1	90
<u>COMMUNICATIONS</u>							
<u>UNITS</u>							
HF-2 Transceiver	9-3-A	375/Lower Avionics Rack, L	5.5	1	5.5	3	93
HF-2 Transceiver Controller	10-3-A	375/Lower Avionics Rack, L	1.56	1	1.56	1	90
HF-2 Antenna Coupler	11-3-A	1200/Center Top Inside	1.4	1	1.4	1	90
Satellite Comm Pwr Amplifier	12-3-A	425/R Avionics Rack	4.0	1	4.0	1	100
<u>ELECTRICAL POWER</u>							
<u>TRANSFORMERS</u>							
26 Vac Transformer #3	13-3-A	375/R EPC	0.8	1	0.8	1	85
<u>UNITS</u>							
Transformer-Rectifier #3	14-3-A	375/R EPC	5.6	1	5.6	3	95
<u>FLIGHT CONTROLS</u>							
<u>UNITS</u>							
Ground Spoiler Cont Unit	15-3-A	375/R EPC	1.0	1	1.0	1	75
R E/R Ratio Sys Programmer	16-3-A	425/R Avionics Rack	0.7	1	0.7	1	85
E/R Ratio Sys Dual Actuator	17-3-A	Base of Vertical Stabilizer Opposite Fuse. Sta. 1300	0.7	1	0.7	1	75
R Auto Slat Actuator	18-3-A	R Wing Leading Edge X _M = 170	3.3	1	3.3	1	70

TABLE A-3
(Continued)
115 VAC SYSTEM - BUS 3

EQUIPMENT DESCRIPTION	LOAD LOCATION CODE	STATION/LOCATION	AMPS PER UNIT	UNITS	CONNECTED LOAD (AMPERES)	PHASES	PERCENT POWER FACTOR
<u>FUEL</u>							
<u>MOTORS</u>							
Center Tank Fwd Fuel Boost Pump	21-3-A	Center Wing Box Tank	7.0	1	7.0	3	74
Tank #4 Fwd Fuel Boost Pump	22-3-A	R Wing Outboard	7.0	1	7.0	3	74
Tank #3 Aft Fuel Boost Pump	23-3-A	R Wing Inboard	7.0	1	7.0	3	74
Fuel Transfer Pump #3	24-3-A	R Wing Inboard	7.0	1	7.0	3	74
<u>UNITS</u>							
Fuel Heat #3	25-3-A	R Wing Inboard	1.2	1	1.2	1	80
<u>HYDRAULIC POWER</u>							
<u>MOTORS</u>							
Aux Hydraulic Pump #1	26-3-A	730/R Landing Gear Pod	65.0	1	65.0	3	75
<u>ICE AND RAIN PROTECTION</u>							
<u>UNITS</u>							
R Eyebrow Window Defog Cont	27-3-A	375/R EPC	6.6	1	6.6	1	90
R Aft Window Defog Cont	28-3-A	375/R EPC	6.6	1	6.6	1	90
R Downview Window Defog Cont	29-3-A	375/R EPC	6.6	1	6.6	1	90
Copilot's Pitot Heat	30-3-A	343/R & Z = -35	3.8	1	3.8	1	90
Aux Pitot Heat	31-3-A	343/R & Z = -53	3.8	2	7.6	1	90
R Angle of Attack Sensor Heat	32-3-A	361/R & Z = -32	2.9	1	2.9	1	100
Total Air Temp Heat	50-3-A	351/R & Z = -27	3.0	1	3.0	1	90
R Alternate Static Port Heat	33-3-A	343/R & Z = -53	3.8	1	3.8	1	90
<u>FURNISHINGS</u>							
<u>MOTORS</u>							
Copilot's Seat (Vert Motor)	34-3-A	325/Copilot's Seat	1.1	1	1.1	3	78
Copilot's Seat (Hor. Motor)	35-3-A	325/Copilot's Seat	1.1	1	1.1	3	80

TABLE A-3
(Continued)
115 VAC SYSTEM - BUS 3

EQUIPMENT DESCRIPTION	LOAD LOCATION CODE	STATION/LOCATION	AMPS PER UNIT	UNITS	CONNECTED LOAD (AMPERES)	PHASES	PERCENT POWER FACTOR
<u>NAVIGATION</u>							
<u>INDICATORS</u>							
Copilot's HSI	36-3-A	275/R Instr Panel	0.26	1	0.26	1	100
Copilot's Vertical Speed Indicator	37-3-A	275/R Instr Panel	0.1	1	0.1	1	90
<u>UNITS</u>							
Station Keeping Radar	38-3-A	425/R Avionics Rack	5.4	1	5.4	1	90
Mission Computer	39-3-A	425/R Avionics Rack	2.7	1	2.7	1	95
Radar Warning Receiver	40-3-A	425/R Avionics Rack	1.4	1	1.4	1	90
Radar Altimeter RCVR-XMTR	41-3-A	760/Z = -90 A/C C _L Lower Compartment	0.83	1	0.83	1	45
<u>UNITS</u>							
R Navigation Computer	42-3-A	425/R Avionics Rack	1.9	1	1.9	1	90
Inertial Nav System #2	43-3-A	425/R Avionics Rack	6.0	1	6.0	1	90
IHS Heater #2	44-3-A	425/R Avionics Rack	9.4	1	9.4	1	100
GPS Receiver/Processor	46-3-A	425/R Avionics Rack	2.6	1	2.6	1	90
<u>PNEUMATIC</u>							
<u>UNITS</u>							
Pneumatic Sys Controller #3	47-3-A	375/R EPC	0.6	1	0.6	1	95
<u>AIR</u>							
<u>UNITS</u>							
Engine Anti-Ice #1	49-3-A	Engine #1	1.2	1	1.2	1	80

TABLE A-4
115 VAC SYSTEM - BUS 4

EQUIPMENT DESCRIPTION	LOAD LOCATION CODE	STATION/LOCATION	AMPS PER UNIT	UNITS	CONNECTED LOAD (AMPERES)	PHASES	PERCENT POWER FACTOR
<u>AIR CONDITIONING</u>							
<u>MOTORS</u>							
Under Floor Fan #1	1-4-A	425/Under R Avionics Rack	7.3	1	7.3	3	75
Cargo Compt Exhaust Fan	2-4-A	675/Under Cargo Compt	7.3	1	7.3	3	78
<u>UNITS</u>							
Cargo Compt Temp Controller	3-4-A	425/R Avionics Rack	1.3	1	1.3	1	88
Right Fan And Venturi	4-4-A	675/R Landing Gear Pod	1.6	1	1.6	1	78
<u>AIRDROP</u>							
<u>UNITS</u>							
R Static Line Retriever Winch Power	5-4-A	435/R Aircraft Wall at A/C C _L	13.6	1	13.6	3	65
<u>ELECTRICAL POWER</u>							
<u>TRANSFORMERS</u>							
26 Vac Transformer #4	6-4-A	375/R EPC	0.8	1	0.8	1	85
<u>UNITS</u>							
115 Vac, Power Frew Converter (400 Hz to 60 Hz)	8-4-A	375/R EPC	19.0	1	19.0	3	85
115 Vac Outlets	9-4-A	375/R Aisle Wall and 925 R Curb	16.0	2	32.0	3	85
<u>FURNISHINGS</u>							
<u>UNITS</u>							
Hot Jug Assembly	10-4-A	325/R of Copilot	8.7	1	8.7	1	100
<u>FUEL</u>							
<u>MOTORS</u>							
Tank #4 Aft Fuel Boost Pump	12-4-A	R Wing Outboard	7.0	1	7.0	3	74
Fuel Transfer Pump #4	13-4-A	R Wing Outboard	7.0	1	7.0	3	74
Tank #3 Fwd Fuel Boost Pump	14-4-A	R Wing Inboard	7.0	1	7.0	3	74
<u>UNITS</u>							
Fuel Heat #4	15-4-A	R Wing Outboard	1.2	1	1.2	1	80

TABLE A-4
(Continued)
115 VAC SYSTEM - BUS 4

EQUIPMENT DESCRIPTION	LOAD LOCATION CODE	STATION/LOCATION	AMPS PER UNIT	UNITS	CONNECTED LOAD (AMPERES)	PHASES	PERCENT POWER FACTOR
<u>HYDRAULIC POWER</u>							
<u>MOTORS</u>							
Aux Hydraulic Pump #2	16-4-A	730/R Landing Gear Pod	65.0	1	65.0	3	75
<u>ICE AND RAIN PROTECTION</u>							
<u>UNITS</u>							
R Windshield Anti-Ice Controller	17-4-A	375/R EPC	12.0	1	12.0	1	90
R Windshield Defog Controller	18-4-A	375/R EPC	6.6	1	6.6	1	90
R Clearview Window Defog Controller	19-4-A	375/R EPC	6.6	1	6.6	1	90
<u>LANDING GEAR</u>							
<u>SOLENOIDS</u>							
R Parking Brake Valve	21-4-A	850/R Landing Gear Pod	3.0	1	3.0	1	70
<u>LIGHTING</u>							
<u>UNITS</u>							
R Wingtip Anti-Collision Light	22-4-A	R Wing Tip	0.7	1	0.7	1	100
R Cargo Loading Area Lights	23-4-A	1135, 1250 & 1355 at Z = +30 R Cargo Loading Area	1.8	3	5.4	1	100
Tail Position Light	24-4-A	Tail	1.8	1	1.8	1	100
R Cargo Area Fluorescent Lights	25-4-A	570, 662, 880, 970, 1062 & 1160 Right Cargo Area Ceiling	1.5	6	9.0	1	58
R Tail Light	26-4-A	725 R Landing Gear Door	7.8	1	7.8	1	100
R Wing Formation Lights	27-4-A	R Wing Tip & R Wing Trailing Edge Fillet	0.43	2	0.87	1	100
R Nacelle Scanning Light	28-4-A	375/Fuselage C _L	0.9	1	0.9	1	100
R Position Light	29-4-A	R Wing Tip	0.87	1	0.87	1	100
R Landing Light	30-4-A	R Wing Tip	5.2	1	5.2	1	100
R Cargo Area Incandescent Lights	31-4-A	570, 662, 880, 990, 1062 & 1160 R Cargo Area Ceiling	1.3	6	7.8	1	100
R Cargo Area Curb Lights	32-4-A	R Cargo Area Curb Fwd & Aft	4.8	1	4.8	1	100
R Staging Area Lights	33-4-A	Under Side of R Hor. Stabilizer	2.6	2	5.2	1	100
R Ramp Lights	34-4-A	R980 & Z = +55 R980 & Z = -25	0.8	2	1.7	1	100

TABLE A-4
(Continued)
115 VAC SYSTEM - BUS 4

EQUIPMENT DESCRIPTION	LOAD LOCATION CODE	STATION/LOCATION	AMPS PER UNIT	UNITS	CONNECTED LOAD (AMPERES)	PHASES	PERCENT POWER FACTOR
Pedestal Instr Pan Lighting Controller	35-4-A	273/Pedestal	0.8	1	0.8	1	100
Copilot's Instr Pan Lighting Controller	36-4-A	R 273	1.0	1	1.0	1	100
Overhead Instr Pan Lighting Controller	37-4-A	273/Overhead Panel	0.8	1	0.8	1	100
<u>NAVIGATION</u>							
<u>INDICATORS</u>							
Copilot Mach Airspeed Indicator	38-4-A	275/Instr Panel	0.15	1	0.15	1	90
<u>PANELS</u>							
R Integrated Nav Control Panel	39-4-A	325/Pedestal R Side	1.0	1	1.0	1	90
<u>UNITS</u>							
Omega Attitude Monitoring & Switching Unit	40-4-A	425/R Avionics Rack	0.9	1	0.9	1	95
	41-4-A	425/R Avionics Rack	0.9	1	0.9	1	95
<u>PNEUMATIC</u>							
<u>UNITS</u>							
Pneumatic Sys Controller #4	42-4-A	375/R EPC	0.6	1	0.6	1	95
<u>AIR</u>							
<u>UNITS</u>							
Engine Anti-Ice #2	44-4-A	Engine #2	1.2	1	1.2	1	80
<u>ENGINE INDICATING</u>							
<u>INDICATORS</u>							
Engine Fuel Flow Indicator	45-4-A	275/Center Instr Panel	0.4	1	0.4	1	90
<u>OIL</u>							
<u>INDICATORS</u>							
Engine Oil Pressure #3 & #4	48-4-A	275/Center Instr Panel	0.1	2	0.2	1	90

TABLE A-5
115 VAC - EMERGENCY BUS

<u>EQUIPMENT DESCRIPTION</u>	<u>LOAD LOCATION CODE</u>	<u>STATION/LOCATION</u>	<u>AMPS PER UNIT</u>	<u>UNITS</u>	<u>CONNECTED LOAD (AMPERES)</u>	<u>PHASES</u>	<u>PERCENT POWER FACTOR</u>
<u>AIR CONDITIONING</u>							
UNITS Cockpit Temp Controller	1-E-A	425/L Avionics Rack	1.3	1	1.3	1	88
<u>ELECTRICAL POWER</u>							
TRANSFORMERS Emergency 28 Vac Bus Transformer	2-E-A	375/L EPC	1.3	1	1.3	1	80
<u>FUEL</u>							
INDICATORS Tank #1 Fuel Quantity	3-E-A	275/Center Instr Panel	0.1	1	0.1	1	54
<u>NAVIGATION</u>							
INDICATORS Pilot Mach Airspeed Indicator	4-E-A	275/L Instr Panel	0.15	1	0.15	1	90
<u>IGNITION</u>							
UNITS Continuous Ignition #1	5-E-A	Engine #1	1.3	1	1.3	1	35
<u>ENGINE INDICATING</u>							
INDICATORS EPR N1	6-E-A 7-E-A	275/Center Instr Panel 275/Center Instr Panel	0.1 0.1	4 4	0.4 0.4	1 1	90 90
<u>AUTO FLIGHT</u>							
UNITS Flt Gdnc Yaw Computer #1	8-E-A	425/L Avionics Rack	1.6	1	1.6	1	95

TABLE A-5
(Continued)
115 VAC - EMERGENCY BUS

EQUIPMENT DESCRIPTION	LOAD LOCATION CODE	STATION/LOCATION	AMPS PER UNIT	UNITS	CONNECTED LOAD (AMPERES)	PHASES	PERCENT POWER FACTOR
<u>COMMUNICATIONS</u>							
<u>UNITS</u>							
Crash Recovery System	9-E-A	1185/Right Size Z = -20	0.8	1	0.8	1	90
HF-1 Transceiver	10-E-A	375/Lower Avionics Rack, L	5.5	1	5.5	3	93
HF-1 Transceiver Controller	11-E-A	375/Lower Avionics Rack, L	1.56	1	1.56	1	90
HF-1 Antenna Coupler	12-E-A	1200/Center Top Inside	1.4	1	1.4	1	90
<u>FUEL</u>							
<u>INDICATORS</u>							
Tank #2 Fuel Quantity	13-E-A	275/Center Instr Panel	0.13	1	0.13	1	54
<u>ICE AND RAIN PROTECTION</u>							
<u>UNITS</u>							
Pilot's Pitot Heat	14-E-A	343/L & Z = -35	3.8	1	3.8	1	90
<u>NAVIGATION</u>							
<u>INDICATORS</u>							
Pilot's HSI	15-E-A	275/Pilot's L Instr Panel	0.26	1	0.26	1	100
<u>UNITS</u>							
Inertial Nav System #1	16-E-A	425/L Avionics Rack	6.0	1	6.0	1	90
INS Heater #1	17-E-A	425/L Avionics Rack	9.4	1	9.4	1	100
<u>IGNITION</u>							
<u>UNITS</u>							
Continuous Ignition #2	18-E-A	Engine #2	1.3	1	1.3	1	35
<u>AUTO FLIGHT</u>							
<u>UNITS</u>							
Flt Gdnc Yaw Computer #2	19-E-A	425/R Avionics Rack	1.6	1	1.6	1	95

TABLE A-5
(Continued)
115 VAC - EMERGENCY BUS

<u>EQUIPMENT DESCRIPTION</u>	<u>LOAD LOCATION CODE</u>	<u>STATION/LOCATION</u>	<u>AMPS PER UNIT</u>	<u>UNITS</u>	<u>CONNECTED LOAD (AMPERES)</u>	<u>PHASES</u>	<u>PERCENT POWER FACTOR</u>
<u>FUEL</u>							
<u>INDICATORS</u>							
Center Tank Fuel Quantity	20-E-A	275/Center Instr Panel	0.13	1	0.13	1	54
Tank #3 Fuel Quantity	21-E-A	275/Center Instr Panel	0.13	1	0.13	1	54
<u>NAVIGATION</u>							
<u>UNITS</u>							
Central Air Data Computer #1	22-E-A	425/R Avionics Rack	1.2	1	1.2	1	77
<u>IGNITION</u>							
<u>UNITS</u>							
Continuous Ignition #3	23-E-A	Engine #3	1.3	1	1.3	1	35
<u>ELECTRICAL POWER</u>							
<u>UNITS</u>							
Transformer-Rectifier #4	24-E-A	375/R EPC	4.8	1	4.8	3	95
<u>FUEL</u>							
<u>INDICATORS</u>							
Tank #4 Fuel Quantity	25-E-A	275/Instr Panel	0.1	1	0.1	1	54
<u>IGNITION</u>							
<u>UNITS</u>							
Continuous Ignition #4	26-E-A	Engine #4	1.3	1	1.3	1	35
<u>ENGINE INDICATING</u>							
<u>INDICATORS</u>							
N2	27-E-A	275/Center Instr Panel	0.1	4	0.4	1	90
EGT	28-E-A	275/Center Instr Panel	0.1	4	0.4	1	90

TABLE A-6

28 VDC SYSTEM - BUS 1

<u>EQUIPMENT DESCRIPTION</u>	<u>LOAD LOCATION CODE</u>	<u>STATION/LOCATION</u>	<u>AMPS PER UNIT</u>	<u>UNITS</u>	<u>CONNECTED LOAD (AMPERES)</u>
<u>AIR CONDITIONING</u>					
<u>AMPLIFIERS</u>					
L Electronic Thermal Sw Control	1-1-D	425/L Avionics Rack	1.0	1	1.0
<u>INDICATORS</u>					
L Pack Discharge Temp	2-1-D	275/Overhead Panel	0.44	1	0.44
Cockpit Duct & Compt Temp	3-1-D	275/Overhead Panel	0.09	1	0.09
Fwd, Center & Aft Cargo Compt Duct & Temp	4-1-D	275/Overhead Panel	0.09	1	0.27
<u>SOLENOIDS</u>					
L Air Cond Reg Valve	5-1-D	660/L Landing Gear Pod	0.6	1	0.6
L Air Cond Turbine Nozzle Valve	6-1-D	660/L Landing Gear Pod	1.0	1	1.0
<u>AUTO FLIGHT</u>					
<u>UNITS</u>					
L Flight Dynamics Computer	7-1-D	425/L Avionics Rack	1.0	1	1.0
L Air Data Computer	8-1-D	425/L Avionics Rack	2.0	1	2.0
<u>COMMUNICATIONS</u>					
<u>AMPLIFIERS</u>					
P.A. Amplifier #2	9-1-D	425/L Avionics Rack	1.9	1	1.9
<u>PANELS</u>					
Integrated Radio Control	10-1-D	325/Pedestal L Side	2.6	1	2.6
Intercom - Pilot	11-1-D	325/Pedestal L Side	1.1	1	1.1
<u>UNITS</u>					
Secure Voice Set #2	12-1-D	425/L Avionics Rack	1.5	1	1.5
<u>ELECTRICAL POWER</u>					
<u>INDICATORS</u>					
CSD #1 011 Press Low	13-1-D	275/Overhead Panel	0.05	1	0.05
<u>RELAYS</u>					
Generator Relay #1	14-1-D	375/L EPC	0.5	1	0.5
Bus Tie Relay #1	15-1-D	375/L EPC	0.5	1	0.5
Left Aux Power Relay	16-1-D	375/L EPC	0.5	1	0.5

TABLE A-6
(Continued)
28 VDC SYSTEM - BUS 1

EQUIPMENT DESCRIPTION	LOAD LOCATION CODE	STATION/LOCATION	AMPS PER UNIT	UNITS	CONNECTED LOAD (AMPERES)
<u>FLIGHT CONTROLS</u>					
INDICATORS					
Flap Position Indic	17-1-D	275/Center Instr Panel	0.08	1	0.08
MOTORS					
RRHP Shut Off Valve	18-1-D	Base of Vertical Stabilizer	2.0	2	4.0
E1 Ld Feel/Flap Lim Programmer #1	19-1-D	Opposite Fus Sta 1300	0.62	1	0.62
E1 Ld Feel Duplex Actuator	20-1-D	425/L Avionics Rack	1.0	1	1.0
Stat Prox Sw & Logic Pwr	21-1-D	Top Fwd floor Stabilizer	1.75	1	1.75
		375/L EPC			
<u>FUEL</u>					
INDICATORS					
Tank Fuel Temp	22-1-D	275/Overhead Panel	0.05	1	0.05
MOTORS					
Tank #1 Crossfeed Valve	23-1-D	Fwd of Tank #1	2.0	1	2.0
<u>HYDRAULIC POWER</u>					
INDICATORS					
Hyd Temp Sys #1	24-1-D	275/Overhead Panel	0.07	1	0.07
MOTORS					
Hydraulic Pump Firewall	25-1-D	Engine #1 Firewall	3.0	1	3.0
Shut Off Valve					
SOLENOIDS					
Engines #1 & #2 L&R Hyd Pump Bypass Valve	26-1-D	Engines #1 & #2	0.83	4	2.5
<u>ICE AND RAIN PROTECTION</u>					
MOTORS					
Left Windshield Wiper	27-1-D	L Windshield	9.0	1	9.0
SOLENOIDS					
Eng #1 First Stage Vane Anti-Ice Valve	28-1-D	Engine #1	1.5	1	1.5
Engine #1 Cowling Anti-Ice Valve	29-1-D	Engine #1	0.8	1	0.8

TABLE A-6
(Continued)
28 VDC SYSTEM - BUS 1

EQUIPMENT DESCRIPTION	LOAD LOCATION CODE	STATION/LOCATION	AMPS PER UNIT	UNITS	CONNECTED LOAD (AMPERES)
<u>LIGHTING</u>					
<u>UNITS</u>					
Master Warning and Caution Controller	30-1-0	425/L Avionics Rack	0.55	1	0.55
<u>NAVIGATION</u>					
<u>UNITS</u>					
LD/ADF Receiver	31-1-0	425/L Avionics Rack	0.7	1	0.7
ILS/VOR/MB Receiver #1	32-1-0	425/L Avionics Rack	0.8	1	0.8
Rate Gyros	33-1-0	425/L Avionics Rack	0.9	1	0.9
<u>PNEUMATIC</u>					
<u>INDICATORS</u>					
Engine #1 Pneu Sys Temp	34-1-0	275/Overhead Panel	0.07	1	0.07
<u>SOLENOIDS</u>					
Engine #3 Pneu Press Regulator Valve	35-1-0	Engine #3	0.5	1	0.5
Engine #1 HP Bleed Cont Valve Sol B	36-1-0	Engine #1	0.5	1	0.5
<u>ENGINE FUEL AND CONTROL</u>					
<u>SOLENOIDS</u>					
Fuel Heat Valve #1	37-1-0	Engine #1	0.8	1	0.8
<u>AIR</u>					
<u>SOLENOIDS</u>					
Compressor 3.5 Bleed Valve	38-1-0	Engine #1	1.2	1	1.2
Rev Actuated 3.5 Bleed Valve	39-1-0	Engine #1	1.0	1	1.0
Press Ratio Bleed Control Vent Valve	40-1-0	Engine #1	2.5	1	2.5
Eng #1 Turbine Case Cooling Valve	41-1-0	Engine #1	1.2	1	1.2

TABLE A-6
(Continued)
28 VDC SYSTEM - BUS 1

<u>EQUIPMENT DESCRIPTION</u>	<u>LOAD LOCATION CODE</u>	<u>STATION/LOCATION</u>	<u>AMPS PER UNIT</u>	<u>UNITS</u>	<u>CONNECTED LOAD (AMPERES)</u>
<u>EXHAUST</u>					
<u>MOTORS</u>					
Thrust Reverser Air-Direction Selector Valve	42-1-D	Engine #1	1.0	1	1.0
Thrust Reverser Air-Press Regulator Valve	43-1-D	Engine #1	1.0	1	1.0
<u>SOLENOIDS</u>					
Reverser Interlock Valve	44-1-D	Engine #1	0.7	1	0.7
<u>OIL</u>					
<u>INDICATORS</u>					
Engine #1 Oil Temp	45-1-D	275/Overhead Panel	0.05	1	0.05

TABLE A-7

2B VDC SYSTEM - BUS 2

<u>EQUIPMENT DESCRIPTION</u>	<u>LOAD LOCATION CODE</u>	<u>STATION/LOCATION</u>	<u>AMPS PER UNIT</u>	<u>UNITS</u>	<u>CONNECTED LOAD (AMPERES)</u>
<u>AUTO FLIGHT</u>					
<u>MOTORS</u>					
Stick Shaker	1-2-D	300/0n L Stick	0.5	1	0.5
<u>PANELS</u>					
FR&CS Control Panel	2-2-D	325/Pedestal	0.8	1	0.8
<u>UNITS</u>					
Flt Gdnc Pitch Compnr #1 (A/P Engaged)	3-2-D	425/L Avionics Rack	8.46	1	8.46
Flt Gdnc Roll Compnr #1	4-2-D	425/L Avionics Rack	1.4	1	1.4
AT/SC Compnr #1	5-2-D	L Avionics Rack	0.73	1	0.73
Auto Pitch Trim (Pwr Sply A)	6-2-D	425/L Avionics Rack	0.78	1	0.78
<u>COMMUNICATIONS</u>					
<u>UNITS</u>					
VHF AM Transceiver #1	7-2-D	425/L Avionics Rack	1.1	1	1.1
Central Comm Switching Unit #1	8-2-D	425/L Avionics Rack	1.8	1	1.8
<u>ELECTRICAL POWER</u>					
<u>INDICATORS</u>					
CSD #1 Oil Press Low	9-2-D	275/Overhead Panel	0.05	1	0.05
CSD 011 Filter Clogged	10-2-D	Overhead Panel	0.3	1	0.3
<u>RELAYS</u>					
Generator Relay #2	11-2-D	375/L EPC	0.5	1	0.5
Bus Tie Relay #2	12-2-D	375/L EPC	0.5	1	0.5
L External Power Relay	13-2-D	375/L EPC	0.5	1	0.5
<u>FUEL</u>					
<u>MOTORS</u>					
Tank #2 Cross Feed Valve	14-2-D	Fwd of Tank #2	2.0	1	2.0
<u>SOLENOIDS</u>					
L & R Fuel Manifold Drain Valve	15-2-D	Fwd Center of Outboard Fuel Tanks	0.8	2	1.6

TABLE A-7
(Continued)
28 VDC SYSTEM - BUS 2

EQUIPMENT DESCRIPTION	LOAD LOCATION CODE	STATION/LOCATION	AMPS PER UNIT	UNITS	CONNECTED LOAD (AMPERES)
<u>HYDRAULIC POWER</u>					
<u>INDICATORS</u>					
Hyd Temp Sys #2	16-2-D	275/Overhead Panel	0.07	1	0.07
<u>MOTORS</u>					
Hydraulic Pump Firewall Shut off Valve	17-2-D	Engine #2 Firewall	3.0	1	3.0
1-3 Hyd Xfr Sys 1 & 2 Valve	18-2-D	890/L Below Cargo Floor	3.0	2	6.0
2-3 Hyd Xfr Sys 1 & 2 Valve	19-2-D	890/A/C Below Cargo Floor	3.0	2	6.0
<u>ICE AND RAIN PROTECTION</u>					
<u>SOLENOIDS</u>					
L Wing Anti-Ice S/O Valve	20-2-D	700/Near L Wing Leading Edge	0.8	1	0.8
L & R Rain Repellent Dispenser Valve	21-2-D	Below L Windshield	1.5	1	1.5
Engine 2 First Stage Vane Anti-Ice Valve	22-2-D	Engine #2	1.5	1	1.5
Eng #2 Cowl Anti-Ice Valve	23-2-D	Engine #2	0.8	1	0.8
<u>LANDING GEAR</u>					
<u>INDICATORS</u>					
Brake Temp Monitor	24-2-D	320/Overhead Panel	1.0	1	1.0
<u>UNITS</u>					
Anti-Skid (Fwd Power)	25-2-D	Same as 33-3-D (See DC Bus 3)	0.5	1	0.5
<u>LIGHTING</u>					
<u>LAMPS</u>					
Copilot Map Lt	26-2-D	325/R of Copilot & Z = +25	0.51	1	0.51
Pilot Map Lt	27-2-D	325/L of Pilot & Z = +25	0.51	1	0.51
<u>PNEUMATIC</u>					
<u>INDICATORS</u>					
Engine #2 Pneu Sys Temp	28-2-D	275/Overhead Panel	0.07	1	0.07
<u>SOLENOIDS</u>					
Eng #1 Pneu Press Regulator Valve	29-2-D	Engine #1	0.5	1	0.5
Eng #2 HP Bleed Cont Valve Sol B	30-2-D	Engine #2	0.5	1	0.5

TABLE A-7
(Continued)
28 VDC SYSTEM - BUS 2

<u>EQUIPMENT DESCRIPTION</u>	<u>LOAD LOCATION CODE</u>	<u>STATION/LOCATION</u>	<u>AMPS PER UNIT</u>	<u>UNITS</u>	<u>CONNECTED LOAD (AMPERES)</u>
<u>ENGINE FUEL AND CONTROL</u>					
<u>SOLENOIDS</u>					
Fuel Heat Valve #2	31-2-D	Engine #2	0.8	1	0.8
<u>ATR</u>					
<u>SOLENOIDS</u>					
Compressor 3.5 Bleed Valve	32-2-D	Engine #2	1.2	1	1.2
Rev Actuated 3.0 Bleed Valve	33-2-D	Engine #2	1.0	1	1.0
Press Ratio Bleed Cont Vent Valve	34-2-D	Engine #2	2.5	1	2.5
Engine #2 Turbine Case Cooling Valve	35-2-D	Engine #2	1.2	1	1.2
<u>EXHAUST</u>					
<u>MOTORS</u>					
Thrust Reverser Air-Direction Selector Valve	36-2-D	Engine #2	1.0	1	1.0
Thrust Reverser Air-Press Reg Valve	37-2-D	Engine #2	1.0	1	1.0
<u>SOLENOIDS</u>					
Reverser Interlock Valve	38-2-D	Engine #2	0.7	1	0.7
<u>OIL</u>					
<u>INDICATORS</u>					
Engine #2 011 Temp	39-2-D	275/Overhead Panel	0.05	1	0.05

TABLE A-8

28 VDC SYSTEM - BUS 3

<u>EQUIPMENT DESCRIPTION</u>	<u>LOAD LOCATION CODE</u>	<u>STATION/LOCATION</u>	<u>AMPS PER UNIT</u>	<u>UNITS</u>	<u>CONNECTED LOAD (AMPERES)</u>
<u>AIR CONDITIONING</u>					
<u>INDICATORS</u>					
Turbine Inlet Temp	1-3-D	275/Overhead Panel	0.04	1	0.04
<u>SOLENOIDS</u>					
L Gnd Air Cond Reg Valve	2-3-D	660/R Landing Gear Pod	0.6	1	0.6
R Air Cond Reg Valve	3-3-D	660/R Landing Gear Pod	0.6	1	0.6
<u>AUTO FLIGHT</u>					
<u>MOTORS</u>					
Stick Shaker	4-3-D	330/On R Stick	0.5	1	0.5
<u>UNITS</u>					
FG&CS Gdnc Pitch Cmptr #2 (A/P Engaged)	6-3-D	425/R Avionics Rack	8.46	1	8.46
Flt Gdnc Roll Cmptr #2	7-3-D	425/R Avionics Rack	1.4	1	1.4
AT/SP Cmptr #2	8-3-D	425/R Avionics Rack	0.73	1	0.73
Auto Pitch Trim (Pwr Sply B)	9-3-D	425/R Avionics Rack	0.78	1	0.78
<u>COMMUNICATIONS</u>					
<u>UNITS</u>					
VHF AM Transceiver #2	10-3-D	425/R Avionics Rack	11.0	1	11.0
UHF Transceiver #2	11-3-D	425/R Avionics Rack	3.9	1	3.9
Central Comm Switching Unit #2	12-3-D	425/R Avionics Rack	1.8	1	1.8
<u>ELECTRICAL POWER</u>					
<u>INDICATORS</u>					
CSD #2 011 Press Low	13-3-D	275/Overhead Panel	0.05	1	0.05
<u>RELAYS</u>					
Generator Relay #3	14-3-D	375/R EPC	0.5	1	0.5
Bus Tie Relay #3	15-3-D	375/R EPC	0.5	1	0.5
Right External Power Relay	16-3-D	375/R EPC	0.5	1	0.5
DC Emer Power Relay	17-3-D	375/R EPC	0.7	1	0.7

TABLE A-8
(Continued)
28 VDC SYSTEM - BUS 3

EQUIPMENT DESCRIPTION	LOAD LOCATION CODE	STATION/LOCATION	AMPS PER UNIT	UNITS	CONNECTED LOAD (AMPERES)
<u>FLIGHT CONTROLS</u>					
<u>INDICATORS</u>					
Speed Brake Lt	18-3-D	275/Center Instr Panel	0.1	1	0.1
<u>UNITS</u>					
ELd Feel/Flap Lim Programmer #2	19-3-D	425/R Avionics Rack	0.62	1	0.62
Flap Duplex Actuator	20-3-D	R Landing Gear Pod	1.0	1	1.0
<u>FUEL</u>					
<u>MOTORS</u>					
Tank #3 Crossfeed Valve	21-3-D	Fwd of Tank #3	2.0	1	2.0
<u>HYDRAULIC POWER</u>					
<u>INDICATORS</u>					
Hyd Temp Sys #3	22-3-D	275/Overhead Panel	0.7	1	0.7
<u>MOTORS</u>					
Hydraulic Pump Firewall	24-3-D	Engine #3 Firewall	3.0	1	3.0
3-4 Hyd Xfr Sys #1 & #2 Valve	25-3-D	890/R Below Cargo Floor	3.0	2	6.0
Hyd Sys #3 Bypass Valve	26-3-D	890/R Below Cargo Floor	3.0	1	3.0
<u>ICE AND RAIN</u>					
<u>SOLENOIDS</u>					
Engine #3 First Stage Vane Anti-Ice Valve	27-3-D	Engine #3	1.5	1	1.5
Engine #3 Cowl Anti-Ice Valve	28-3-D	Engine #3	0.8	1	0.8
R Wing Anti-Ice S/O Valve	29-3-D	700/Near R Wing Leading Edge	0.8	1	0.8
<u>LANDING GEAR</u>					
<u>INDICATORS</u>					
Landing Gear Position	30-3-D	275/Center Instr Panel	0.64	1	0.64
Auto Brake Control Manifold-Servo Valve	31-3-D	R Landing Gear Pod	1.0	1	1.0
<u>UNITS</u>					
Proximity Electronics Unit	32-3-D	275/R EPC	0.75	1	0.75
Anti-Skid (Aft Power)	33-3-D	425/R Avionics Rack One Controller per Aircraft	0.5	1	0.5

TABLE A-8
(Continued)
28 VDC SYSTEM - BUS 3

<u>EQUIPMENT DESCRIPTION</u>	<u>LOAD LOCATION CODE</u>	<u>STATION/LOCATION</u>	<u>AMPS PER UNIT</u>	<u>UNITS</u>	<u>CONNECTED LOAD (AMPERES)</u>
<u>LIGHTING</u>					
<u>LAMPS</u>					
R Ovhd Panel Flood Light	34-3-D	330/R & Z = +60 Above R CV/Sw Divider	0.64	1	0.64
Left Pedestal Flood Light	35-3-D	330/L Cockpit Ceiling	0.64	1	0.65
L Ovhd Panel Flood Light	36-3-D	380/L & Z = +60 Above L CV/Sw Divider	0.64	1	0.64
<u>NAVIGATION</u>					
<u>UNITS</u>					
Station Keeping Radar System	37-3-D	425/R Avionics Rack	4.0	1	4.0
<u>PNEUMATIC</u>					
<u>INDICATORS</u>					
Engine #3 Pneu Sys Temp	38-3-D	275/Overhead Panel	0.07	1	0.07
<u>SOLENOIDS</u>					
Engine #1 Pneu Press Reg Valve	39-3-D	Engine #1	0.5	1	0.5
Engine #3 IIP Bleed Valve Sol B	40-3-D	Engine #3	0.5	1	0.5
<u>ENGINE FUEL AND CONTROL</u>					
<u>SOLENOIDS</u>					
Fuel Heat Valve #3	41-3-D	Engine #3	0.8	1	0.8
<u>AIR</u>					
<u>SOLENOIDS</u>					
Compressor 3.5 Bleed Valve	42-3-D	Engine #3	1.2	1	1.2
Rev Actuated 3.0 Bleed Valve	43-3-D	Engine #3	1.0	1	1.0
Press Ratio Bleed Cont Vent Valve	44-3-D	Engine #3	2.5	1	2.5
Eng #3 Turbine Case Cooling Valve	45-3-D	Engine #3	1.2	1	1.2

TABLE A-8
(Continued)
28 VDC SYSTEM - BUS 3

EQUIPMENT DESCRIPTION	LOAD LOCATION CODE	STATION/LOCATION	AMPS PER UNIT	UNITS	CONNECTED LOAD (AMPERES)
<u>EXHAUST</u>					
<u>MOTORS</u>					
Thrust Reverser Air-Direction Selector Valve	46-3-D	Engine #2	1.0	1	1.0
Thrust Reverser Air-Press Reg Valve	47-3-D	Engine #2	1.0	1	1.0
<u>OIL</u>					
<u>INDICATORS</u>					
Engine #3 011 Temp	48-3-D	275/Overhead Panel	0.05	1	0.05

TABLE A-9

28 VDC SYSTEM - BUS 4

EQUIPMENT DESCRIPTION	LOAD LOCATION CODE	STATION/LOCATION	AMPS PER UNIT	UNITS	CONNECTED LOAD (AMPERES)
<u>AIR CONDITIONING</u>					
AMPLIFIERS					
R Electronic Thermal Sw Control	1-4-D	425/R Avionics Rack	1.0	1	1.0
INDICATORS					
R Pack Discharge Temp	2-4-D	275/Overhead Panel	0.44	1	0.44
MOTORS					
Air Outflow Valve Actuator	3-4-D	660/R Landing Gear Pod	0.6	1	0.6
SOLENOIDS					
R Gnd Air Cond Reg Valve	4-4-D	660/R Landing Gear Pod	0.6	1	0.6
R Air Cond Turbine Nozzle Valve	5-4-D	660/R Landing Gear Pod	1.0	1	1.0
<u>AUTO FLIGHT</u>					
<u>UNITS</u>					
R Flight Dynamics Computer	6-4-D	475/R Avionics Rack	1.0	1	1.0
R Air Data Computer	7-4-D	425/R Avionics Rack	2.0	1	2.0
<u>COMMUNICATIONS</u>					
<u>AMPLIFIERS</u>					
P.A. Amplifier #3	8-4-D	425/R Avionics Rack	2.0	1	2.0
<u>PANELS</u>					
Intercom: Jump Master	9-4-D	1085/R Jump Door	1.1	1	1.1
<u>UNITS</u>					
Secure Voice Set #3	10-4-D	425/R Avionics Rack	1.5	1	1.5
WHF FM Transceiver	11-4-D	425/R Avionics Rack	3.9	1	3.9
<u>ELECTRICAL POWER</u>					
<u>INDICATORS</u>					
CSD #4 011 Press Low	41-4-D	Overhead Panel	0.05	1	0.05
<u>RELAYS</u>					
Generator Relay #4	12-4-D	375/R EPC	0.5	1	0.5
Bus Tie Relay #4	13-4-D	375/R EPC	0.5	1	0.5
Right Aux Power Relay	14-4-D	375/R EPC	0.5	1	0.5

TABLE A-9
(Continued)
28 VDC SYSTEM - BUS 4

<u>EQUIPMENT DESCRIPTION</u>	<u>LOAD LOCATION CODE</u>	<u>STATION/LOCATION</u>	<u>AMPS PER UNIT</u>	<u>UNITS</u>	<u>CONNECTED LOAD (AMPERES)</u>
<u>FLIGHT CONTROLS</u>					
<u>MOTORS</u>					
Primary Trim Drive	15-4-D	Top of Vertical Stabilizer	4.0	1	4.0
<u>RELAYS</u>					
Primary Trim Down Relay	16-4-D	375/L EPC	0.9	1	0.9
Primary Trim Up Relay	17-4-D	375/L EPC	0.9	1	0.9
<u>FUEL</u>					
<u>MOTORS</u>					
Tank #4 Crossfeed Valve	18-4-D	Fwd of Tank #4	2.0	1	2.0
<u>HYDRAULIC POWER</u>					
<u>INDICATORS</u>					
Hyd Temp Sys #4	19-4-D	275/Center Instr Panel	0.07	1	0.07
<u>SOLENOIDS</u>					
Engines #3 & #4 L&R Hyd Pump Bypass Valve	20-4-D	Engines #3 & #4	0.83	4	2.5
<u>MOTORS</u>					
Hydraulic Pump Firewall Shutoff Valve	21-4-D	Engine #4 Firewall	3.0	1	3.0
<u>ENGINE FUEL AND CONTROL</u>					
<u>SOLENOIDS</u>					
Fuel Heat #4	33-4-D	Engine #4	0.8	1	0.8
<u>AIR</u>					
<u>SOLENOIDS</u>					
Compressor 3.5 Bleed Valve	34-4-D	Engine #4	1.2	1	1.2
Rev Actuated 3.0 Bleed Valve	35-4-D	Engine #4	1.0	1	1.0
Press Ratio Bleed Cont Vent Valve	36-4-D	Engine #4	2.5	1	2.5
Eng #4 Turbine Case Cooling Valve	37-4-D	Engine #4	1.2	1	1.2

TABLE A-9
(Continued)
28 VDC SYSTEM - BUS 4

<u>EQUIPMENT DESCRIPTION</u>	<u>LOAD LOCATION CODE</u>	<u>STATION/LOCATION</u>	<u>AMPS PER UNIT</u>	<u>UNITS</u>	<u>CONNECTED LOAD (AMPERES)</u>
<u>EXHAUST</u>					
<u>MOTORS</u>					
Thrust Reverser Air-Direction Selector Valve	38-4-D	Engine #4	1.0	1	1.0
Thrust Reverser Air Press Reg Valve	39-4-D	Engine #4	1.0	1	1.0
<u>OIL</u>					
<u>INDICATORS</u>					
Engine #4 Oil Temp	40-4-D	275/Overhead Panel	0.05	1	0.05
<u>ICE AND RAIN PROTECTION</u>					
<u>MOTORS</u>					
Right Windsheld Wiper	22-4-D	R Windsheld	9.0	1	9.0
Eng #4 First Stage Vane Anti-Ice Valve	23-4-D	Engine #4	1.5	1	1.5
Eng #4 Cowl Anti-Ice Valve	24-4-D	Engine #4	0.8	1	0.8
<u>SOLENOIDS</u>					
R Rain Repellent Dispenser Valve	25-4-D	Below R Windsheld	1.5	1	1.5
<u>UNITS</u>					
Heater Controller/Monitor	26-4-D	310/Ovhd Panel	0.6	1	0.6
<u>LIGHTING</u>					
<u>LAMPS</u>					
R Pedestal Flood Light	27-4-D	330/R Cockpit Ceiling	0.64	1	0.64
Flt Gdnc & Con Pnl Flood Light	28-4-D	330/R Z = +60 Above CV/Sw Post	0.78	1	0.78
<u>NAVIGATION</u>					
<u>UNITS</u>					
Attitude Monitor & Switching Unit	29-4-D	425/R Avionics Rack	0.5	1	0.5

TABLE A-9
(Continued)
28 VDC SYSTEM - BUS 4

<u>EQUIPMENT DESCRIPTION</u>	<u>LOAD LOCATION CODE</u>	<u>STATION/LOCATION</u>	<u>AMPS PER UNIT</u>	<u>UNITS</u>	<u>CONNECTED LOAD (AMPERES)</u>
<u>PNEUMATIC</u>					
<u>INDICATORS</u>					
Engine #4 Pneu Sys Temp	30-4-D	275/Overhead Panel	0.07	1	0.07
<u>SOLENOIDS</u>					
Eng #4 HP Bleed Valve	31-4-D	Engine #4	0.5	1	0.5
Eng #2 Pneu Press Reg Valve	32-4-D	Engine #2	0.5	1	0.5

TABLE A-10

28 VDC SYSTEM - EMERGENCY BUS

<u>EQUIPMENT DESCRIPTION</u>	<u>LOAD LOCATION CODE</u>	<u>STATION/LOCATION</u>	<u>AMPS PER UNIT</u>	<u>UNITS</u>	<u>CONNECTED LOAD (AMPERES)</u>
<u>AIR CONDITIONING</u>					
<u>SOLENOIDS</u>					
Pack 1, 2, 3, 4 Flow Control Valve	1-E-D	660/L & R Landing Gear Pods	0.75	4	3.0
<u>AUTO FLIGHT</u>					
<u>UNITS</u>					
Fit Gdnc Yaw Comptr #1 (Sply A)	2-E-D	425/L Avionics Rack	4.2	1	4.2
Fit Gdnc Yaw Comptr #1 (Sply B)	3-E-D	425/L Avionics Rack	3.5	1	3.5
<u>COMMUNICATIONS</u>					
<u>AMPLIFIERS</u>					
Public Address #1	4-E-D	425/L Avionics Rack	2.1	1	2.1
<u>PANELS</u>					
Intercom	5-E-D	325/L & R Pedestal	0.7	3	2.1
Aux Comm Control	6-E-D	325/L Pedestal	1.0	1	1.0
<u>UNITS</u>					
UIF Comm #1 Transceiver:XMT	7-E-D	425/L Avionics Rack	4.2	1	4.2
UIF Comm #1 Transceiver:REC	8-E-D	425/R Avionics Rack	1.7	1	1.7
IFF Transponder	9-E-D	425/R Avionics Rack	3.8	1	3.8
VIIF Transceiver	10-E-D	425/L Avionics Rack	7.0	1	7.0
<u>FUEL</u>					
<u>SOLENOIDS</u>					
Fuel Crossfeed Valves	11-E-D	Near Center of Leading Edge of Tank #2 and Near Inboard Leading Edge of Tanks #1 & #3	0.77	3	2.3

TABLE A-10
(Continued)
28 VDC SYSTEM - EMERGENCY BUS

<u>EQUIPMENT DESCRIPTION</u>	<u>LOAD LOCATION CODE</u>	<u>STATION/LOCATION</u>	<u>AMPS PER UNIT</u>	<u>UNITS</u>	<u>CONNECTED LOAD (AMPERES)</u>
<u>LIGHTING</u>					
<u>UNITS</u>					
Cargo Compartment Standby L, Center, & R Instr Panels Flood Lts	12-E-D	570, 662, 880, 970 L, Center, & R Under Shield	1.3	6	7.8
Emergency Lts Battery Power Supply, Fwd-Mid-Aft	13-E-D		0.68	3	2.0
	14-E-D	L & R Side, Z = -10 at 385, 735 & 880	3.6	6	21.6
<u>NAVIGATION</u>					
<u>UNITS</u>					
ILS/VOR/MB Receiver #2	16-E-D	425/R Avionics Rack	0.8	1	0.8

TABLE A-11

28 VDC SYSTEM - BATTERY BUS

EQUIPMENT DESCRIPTION		LOAD LOCATION CODE	STATION/LOCATION	AMPS PER UNIT	UNITS	CONNECTED LOAD (AMPERES)
<u>COMMUNICATIONS</u>						
<u>UNITS</u>						
Intercom: Copilot		1-BB	325/Pedestal R Side	1.1	1	1.1
Intercom: Jump Master		2-BB	1085/R Jump Door	1.1	1	1.1
Intercom: Observer		3-BB	375/R EPC Aisle Wall	1.1	1	1.1
Intercom: Jump Master		4-BB	1085/L Jump Door	1.1	1	1.1
Intercom: Pilot		5-BB	325/Pedestal L Side	1.1	1	1.1
<u>ELECTRICAL POWER</u>						
<u>UNITS</u>						
Static Inverter		6-BB	360/Lower L EPC	32.4	1	32.4
Generator Control #1 & #2		7-BB	375/L EPC	0.5	2	1.0
Generator Control #3 & #4		8-BB	375/R EPC	0.5	2	1.0
<u>FUEL</u>						
<u>SOLENOIDS</u>						
Aerial Refueling Valve		9-BB	400/C _L & +Z = Max	1.0	1	1.0
Ground Refueling Shutoff Valve		10-BB	835/C _L Near Center Tank	1.0	1	1.0
<u>MOTORS</u>						
Engine Start Pump		11-BB	725/Center Wing Box Tank	4.75	1	4.75
<u>HYDRAULIC POWER</u>						
<u>SOLENOIDS</u>						
Engine Hyd Pump Depress Valve		12-BB	Engines #1, #2, #3, #4	1.0	4	4.0
<u>INSTRUMENTS</u>						
<u>UNITS</u>						
Central Aural Warning		13-BB	425/L Avionics Rack	.72	1	.72

TABLE A-11
(Continued)
28 VDC SYSTEM - BATTERY BUS

EQUIPMENT DESCRIPTION	LOAD LOCATION CODE	STATION/LOCATION	AMPS PER UNIT	UNITS	CONNECTED LOAD (AMPERES)
<u>LIGHTS</u>					
<u>LAMPS</u>					
Standby Ovhd Panel Lighting	14-BB	310/Ovhd Sw Panel	0.7	1	0.7
FWAC Controller	15-BB	425/L Avionics Rack	0.55	1	0.55
<u>NAVIGATION</u>					
<u>INSTRUMENTS</u>					
Standby Attitude Indicator	16-BB	310/Ovhd Sw Panel	0.32	1	0.32
<u>PNEUMATIC</u>					
<u>SOLENOIDS</u>					
Isolation Valves	17-BB	700/3 At Fuselage Near L&R Wing Leading Edges	0.5	6	3.0
<u>AIRBORNE AUXILIARY POWER</u>					
<u>HORN</u>					
APU Fire Warning	18-BB	365/L Aft of Pilot	10.0	1	10.0
<u>MOTORS</u>					
APU Inlet & Exhaust Doors	19-BB	APU Compartment	5.2	1	5.2
<u>ACTUATOR</u>					
APU Start Pump	20-BB	APU Compartment	5.0	1	5.0
<u>RELAYS</u>					
APU Start Relay	21-BB	375/Lower L EPC	0.8	1	0.8
<u>SOLENOIDS</u>					
APU Fuel Shutoff Valve	22-BB	APU Compartment	1.23	2	2.5
APU Screen Anti-Ice Valve	23-BB	APU Compartment	0.5	1	0.5
<u>UNITS</u>					
APU Electronic Control	24-BB	APU Compartment	7.25	1	7.25
APU Generator Control	25-BB	375/L EPC	0.5	1	0.5

TABLE A-11
(Continued)
28 VDC SYSTEM - BATTERY BUS

<u>EQUIPMENT DESCRIPTION</u>	<u>LOAD LOCATION CODE</u>	<u>STATION/LOCATION</u>	<u>AMPS PER UNIT</u>	<u>UNITS</u>	<u>CONNECTED LOAD (AMPERES)</u>
<u>ENGINE FUEL AND CONTROL</u>					
<u>SOLENOIDS</u>					
Engine Vapor Vent Valve	26-BB	Engines #1, #2, #3, & #4	1.5	4	6.0
Engine Ground Idle Solenoid	27-BB	Engines #1, #2, #3, & #4	1.0	4	4.0
<u>IGNITION</u>					
<u>SOLENOIDS</u>					
Engine Starter Valves	28-BB	Engines #1, #2, #3, & #4	1.25	4	5.0

TABLE A-12

28 VDC SYSTEM - BATTERY DIRECT BUS

<u>EQUIPMENT DESCRIPTION</u>	<u>LOAD LOCATION CODE</u>	<u>STATION/LOCATION</u>	<u>AMPS PER UNIT</u>	<u>UNITS</u>	<u>CONNECTED LOAD (AMPERES)</u>
<u>ELECTRICAL POWER</u>					
<u>SOLENOIDS</u>					
CSD Disconnect	1-BD	CSD's #1, #2, #3, & #4	19.0	4	76.0
Emergency Inverter	2-BD	375/L EPC	19.2	1	19.2
<u>FIRE PROTECTION</u>					
<u>UNITS</u>					
Fire Ex. Bottles	3-BD	Engines #1, #2, #3, #4 & APU	8.0	5	40.0
Engine & APU Fire Detection Controller	4-BD	Engines #1, #2, #3, #4 & APU	0.83	5	4.2
<u>FUEL</u>					
<u>SOLENOIDS</u>					
Tank Fuel Shut-off Precheck Valve	5-BD	Wing Trailing Edge Aft of Tanks #1, #2, #3 & #4 and Aft of Wing Box Center Tank	1.0	5	5.0
<u>NAVIGATION</u>					
<u>UNITS</u>					
Inertial Sensor Unit #1	6-BD	425/L Avionics Rack	10.0	1	10.0
Inertial Sensor Unit #2	7-BD	425/R Avionics Rack	10.0	1	10.0
IHS Aural Warning (Logic & Horn)	8-BD	425/L Avionics Rack	13.0	1	13.0
<u>AIRBORNE AUXILIARY POWER</u>					
<u>MOTORS</u>					
APU Starter	9-BD	1462/APU Compartment	190.0	1	190.0

APPENDIX B
DETAILED LOAD LOCATION LISTS

The various loads from Appendix A have been re-organized and listed herein according to their physical location in the C-15 airplane. Each load is identified by its load identification code (e.g. 7-3-A which is load serial number 7 on Bus 3 of the AC system; 3-BB is load serial number 3 on the DC Battery Bus). These lists also show the current required by the load, the "ideal" circuit breaker trip rating based upon a 75% maximum initial connected load, and the selected, next larger or in some cases the nearest, standard SSPC trip-rating size. For example, in the right-hand electrical power center area (R-EPC), a load is designated as follows:

27-3-A
6.6
(8.8) [10]

This indicates that load serial number 27 is supplied by BUS 3 from the AC system; it is a 6.6 ampere connected load; it would be ideally protected by an 8.8 ampere protective device (CB, RCCB or SSPC), and a standard 10 ampere protective device is selected for this load circuit. Looking into Appendix A, Load 27-3-A is found to be in the ice and rain protection group. Load 27-3-A is the Right Eyebrow Window Defog Controller at Station Location 375, it consists of one 6.6 ampere unit, single phase 115 VAC supply, and has a 90 percent power factor (lagging) characteristic.

TABLE B-1
AC LOAD LOCATIONS

Nose	L Instr Panel	C Instr Panel	R Instr Panel	Overhead Panel	Pedestal	Low EPC L
14-E-A 3.8 (5.1) [5]	33-1-A 0.87 (1.2) [1.6]	3-E-A 0.1 (0.13) [0.5]	20-E-A 0.13 (0.17) [0.5]	34-1-A 0.87 (1.2) [1.6]	36-1-A 1.0 (1.3) [1.6]	8-1-A 0.9 (1.2) [1.6]
29-2-A 2.9 (3.8) [5]	4-E-A 0.15 (0.2) [0.5]	42-1-A 0.3 (0.4) [0.5]	21-E-A 0.13 (0.17) [0.5]	36-3-A 0.26 (0.34) [0.5]	38-2-A 1.3 (1.7) [2]	
30-2-A 3.8 (5.1) [5]	33-2-A 0.1 (0.13) [0.5]	6-E-A 0.4 (0.53) [0.5]	25-E-A 0.1 (0.13) [0.5]	37-3-A 0.1 (0.13) [0.5]	35-4-A 0.8 (1.1) [1.6]	
30-3-A 3.8 (5.1) [5]	15-E-A 0.26 (0.34) [0.5]	7-E-A 0.4 (0.53) [0.5]	45-4-A 0.4 (0.53) [0.5]	36-4-A 1.0 (1.3) [1.6]	39-4-A 1.0 (1.3) [1.6]	
31-3-A 7.6 (10.1) [10]		45-1-A 0.2 (0.26) [0.5]	27-E-A 0.4 (0.53) [0.5]	38-4-A 0.15 (0.2) [0.5]	10-1-A 8.7 (11.6) [15]	
32-3-A 2.9 (3.8) [5]		46-1-A 0.2 (0.26) [0.5]	28-E-A 0.4 (0.53) [0.5]		31-2-A 1.1 (1.46) [1.6]	
33-3-A 3.8 (5.1) [5]		2-2-A 0.3 (0.4) [0.5]	48-4-A 0.2 (0.26) [0.5]		32-2-A 1.1 (1.46) [1.6]	
50-3-A 3.0 (4.0) [5]		13-E-A 0.13 (0.17) [0.5]			34-3-A 1.1 (1.46) [1.6]	
		18-2-A 0.1 (0.13) [0.5]			35-3-A 1.1 (1.46) [1.6]	
		2-3-A 0.3 (0.4) [0.5]			10-4-A 8.7 (11.6) [15]	

TABLE B-1
(Continued)
AC LOAD LOCATIONS

L EPC		R EPC		L AV Rack		R AV Rack	
2-1-A 1.6 (2.2) [3]	26-2-A 6.6 (8.8) [10]	13-3-A 0.8 (1.1) [1.6]	17-4-A 12 (16) [20]	1-1-A 7.3 (9.73) [10]	15-2-A 0.7 (0.93) [1.6]	1-3-A 7.3 (9.73) [10]	40-3-A 1.4 (1.86) [2]
2-E-A 1.3 (1.7) [2]	27-2-A 6.6 (8.8) [10]	14-3-A 5.6 (7.5) [7.5]	18-4-A 6.6 (8.8) [10]	1-E-A 1.3 (1.7) [2]	35-2-A 1.9 (2.5) [3]	3-3-A 1.3 (1.7) [2]	42-3-A 1.9 (2.5) [3]
7-1-A 0.8 (1.1) [1.6]	42-2-A 0.6 (0.8) [1.6]	15-3-A 1.0 (1.3) [1.6]	19-4-A 6.6 (8.8) [10]	37-1-A 0.9 (1.2) [1.6]	16-E-A 6.0 (8.0) [10]	4-3-A 0.77 (1.0) [1.6]	43-3-A 6.0 (8.0) [10]
9-1-A 4.8 (6.4) [7.5]	19-1-A 6.6 (8.8) [10]	27-3-A 6.6 (8.8) [10]	42-4-A 0.6 (0.8) [1.6]	38-1-A 0.9 (1.2) [1.6]	17-E-A 9.4 (12.5) [15]	5-3-A 2.0 (2.7) [3]	44-3-A 9.4 (12.5) [15]
17-1-A 12 (16) [20]		28-3-A 6.6 (8.8) [10]		3-2-A 1.3 (1.7) [2]	39-2-A 2.0 (2.7) [3]	6-3-A 1.8 (2.4) [3]	22-E-A 1.2 (1.6) [1.6]
18-1-A 6.6 (8.8) [10]		29-3-A 6.6 (8.8) [10]		4-2-A 0.77 (1.0) [1.6]	40-2-A 2.6 (3.5) [5]	19-E-A 1.6 (2.1) [3]	46-3-A 2.6 (3.5) [5]
39-1-A 0.6 (0.8) [1.6]		47-3-A 0.6 (0.8) [1.6]		5-2-A 2.0 (2.7) [3]	41-2-A 1.2 (1.6) [1.6]	12-3-A 4.0 (5.3) [7.5]	3-4-A 1.3 (1.7) [2]
13-2-A 0.8 (1.1) [1.6]		6-4-A 0.8 (1.1) [1.6]		6-2-A 1.8 (2.4) [3]	1-2-A 7.3 (9.73) [10]	16-3-A 0.7 (0.9) [1.6]	40-4-A 0.9 (1.2) [1.6]
14-2-A 5.5 (7.3) [7.5]		24-E-A 4.8 (6.4) [7.5]		8-E-A 1.6 (2.1) [3]		38-3-A 5.4 (7.2) [7.5]	41-4-A 0.9 (1.2) [1.6]
25-2-A 6.6 (8.8) [10]		8-4-A 19 (25.3) [25]		8-2-A 0.9 (1.2) [1.6]		39-3-A 2.7 (3.6) [5]	1-4-A 7.3 (9.7) [10]

TABLE B-1
(Continued)
AC LOAD LOCATIONS

Low AV L	Fwd Cargo Area	L Wing	Ctr Wing Box	R Wing
10-E-A 5.5 (7.3) [7.5]	5-1-A 13.6 (18) [20]	12-1-A 7.0 (9.3) [10]	19-2-A 7.0 (9.3) [10]	18-3-A 3.3 (4.4) [5]
11-E-A 1.56 (2.1) [3]	23-1-A 4.5 (6) [7.5]	13-1-A 7.0 (9.3) [10]	21-3-A 7.0 (9.3) [10]	12-4-A 7.0 (9.3) [10]
9-3-A 5.5 (7.3) [7.5]	26-1-A 0.9 (1.2) [1.6]	14-1-A 7.0 (9.3) [10]	25-1-A 0.43 (0.57) [0.5]	13-4-A 7.0 (9.3) [10]
10-3-A 1.56 (2.1) [3]	29-1-A 3.9 (5.2) [7.5]	15-1-A 1.2 (1.6) [1.6]	25-1-A 0.43 (0.57) [0.5]	14-4-A 7.0 (9.3) [10]
	30-1-A 4.8 (6.4) [7.5]	21-1-A 0.7 (0.93) [1.6]		15-4-A 1.2 (1.6) [1.6]
	8-3-A 0.7 (0.93) [1.6]	27-1-A 0.87 (1.16) [1.6]		22-3-A 7.0 (9.3) [10]
	41-3-A 0.83 (1.1) [1.6]	28-1-A 5.2 (6.9) [7.5]		23-3-A 7.0 (9.3) [10]
	2-4-A 7.3 (9.7) [10]	20-2-A 7.0 (9.3) [10]		24-3-A 7.0 (9.3) [10]
	5-4-A 13.6 (18) [20]	21-2-A 7.0 (9.3) [10]		25-3-A 1.2 (1.6) [1.6]
	9-4-A 16 (21.3) [25]	22-2-A 7.0 (9.3) [10]		22-4-A 0.7 (1.3) [1.6]
				29-4-A 0.87 (1.16) [1.6]
				30-4-A 5.2 (6.9) [7.5]

TABLE B-1
(Continued)
AC LOAD LOCATIONS

L Pod	R Pod	Eng #1	Eng #2	Eng #3	Eng #4	Aft Cargo Area	Tail
4-1-A 1.6 (2.2) [3]	16-1-A 65 (86.6) [100]	5-E-A 1.3 (1.7) [2]	47-1-A 1.2 (1.6) [1.6]	41-1-A 1.2 (1.6) [1.6]	44-2-A 1.2 (1.6) [1.6]	29-1-A 3.9 (5.2) [7.5]	22-1-A 5.4 (7.2) [7.5]
20-1-A 3.0 (4.0) [5]	26-3-A 65 (86.6) [100]	49-3-A 1.2 (1.6) [1.6]	18-E-A 1.3 (1.7) [2]	20-4-A 1.2 (1.6) [1.6]	26-E-A 1.3 (1.7) [2]	9-4-A 16 (21.3) [25]	31-1-A 5.2 (6.9) [7.5]
24-2-A 65 (86.6) [100]	4-4-A 1.6 (2.2) [3]		44-4-A 1.2 (1.6) [1.6]	23-E-A 1.3 (1.7) [2]		23-4-A 5.4 (7.2) [7.5]	9-E-A 0.8 (1.06) [1.6]
24-1-A 7.8 (10.4) [15]	16-4-A 65 (86.6) [100]					25-4-A 4.5 (6.0) [7.5]	17-3-A 0.7 (0.93) [1.6]
	21-4-A 3.0 (4.0) [5]					23-1-A 4.5 (6.0) [7.5]	24-4-A 1.8 (2.4) [3]
	26-4-A 7.8 (10.4) [15]					32-1-A 1.7 (2.26) [3]	33-4-A 5.2 (6.93) [7.5]
						31-4-A 3.9 (5.2) [7.5]	12-E-A 1.4 (1.86) [2]
						34-4-A 1.7 (2.26) [3]	11-3-A 1.4 (1.86) [2]

TABLE B-2

DC LOAD LOCATIONS

R Instr Panel	C Instr Panel	L Instr Panel	Overhead Panel	Pedestal
22-4-D 9.0 (12) [15]	17-1-D 0.08 (0.1) [0.5]	27-1-D 9.0 (12) [15]	2-1-D 0.44 (0.58) [1.6]	10-1-D 2.6 (3.46) [5]
25-4-D 1.5 (2.0) [2]	18-3-D 0.1 (0.13) [0.5]	21-2-D 1.5 (2.0) [2]	3-1-D 0.09 (0.12) [0.5]	11-1-D 1.1 (1.46) [1.6]
13-E-D 0.68 (0.9) [1.6]	5-3-D 0.5 (0.66) [1.6]	13-E-D 0.68 (0.9) [1.6]	4-1-D 0.27 (0.36) [0.5]	2-2-D 0.8 (1.06) [1.6]
	30-3-D 0.64 (0.85) [1.6]		13-1-D 0.05 (0.06) [0.5]	5-E-D 0.7 (0.93) [1.6]
	13-E-D 0.68 (0.9) [1.6]		22-1-D 0.05 (0.06) [0.5]	5-E-D 0.7 (0.93) [1.6]
			24-1-D 0.07 (0.09) [0.5]	6-E-D 1.0 (1.33) [1.6]
			45-1-D 0.05 (0.06) [0.5]	1-BB 1.1 (1.46) [1.6]
			9-2-D 0.05 (0.06) [0.5]	5-BB 1.1 (1.46) [1.6]
			10-2-D 0.3 (0.4) [0.5]	26-2-D 0.51 (0.68) [1.6]
			16-2-D 0.07 (0.09) [0.5]	27-2-D 0.51 (0.68) [1.6]
			22-3-D 0.7 (0.9) [1.6]	
			48-3-D 0.05 (0.06) [0.5]	
			2-4-D 0.44 (0.58) [1.6]	
			19-4-D 0.07 (0.09) [0.5]	
			40-4-D 0.05 (0.06) [0.5]	
			41-4-D 0.05 (0.06) [0.5]	
			34-1-D 0.07 (0.09) [0.5]	
			16-BB 0.32 (0.42) [0.5]	
			30-4-D 0.07 (0.09) [0.5]	
			26-4-D 0.6 (0.8) [1.6]	18-BB 10 (13.3) [15]
			38-3-D 0.07 (0.09) [0.5]	
			1-3-D 0.04 (0.05) [0.5]	
			39-2-D 0.05 (0.06) [0.5]	
			28-2-D 0.07 (0.09) [0.5]	
			1-2-D 0.5 (0.66) [1.6]	
			4-3-D 0.5 (0.66) [1.6]	

TABLE B-2
(Continued)
DC LOAD LOCATIONS

Other Cockpit	L EPC	R EPC	L EPC L	L Wing	Ctr Wing Box	R Wing
9-88 1.0 (1.33) [1.6]	14-1-D 0.5 (0.66) [1.6]	14-3-D 0.5 (0.66) [1.6]	6-88 32.4 (43.2) [50]	11-E-D 0.77 (1.02) [1.6]	5-80 1.0 (1.33) [1.6]	29-3-D 0.8 (1.1) [1.6]
34-3-D 0.64 (0.85) [1.6]	15-1-D 0.5 (0.66) [1.6]	15-3-D 0.5 (0.66) [1.6]	21-88 0.8 (1.1) [1.6]	11-E-D 0.77 (1.02) [1.6]	10-88 1.0 (1.33) [1.6]	18-4-D 2.0 (2.66) [3]
35-3-D 0.64 (0.85) [1.6]	16-1-D 0.5 (0.66) [1.6]	16-3-D 0.5 (0.66) [1.6]		5-80 1.0 (1.33) [1.6]	11-88 4.75 (6.32) [7.5]	11-E-D 0.77 (1.02) [1.6]
36-3-D 0.64 (0.85) [1.6]	11-2-D 0.5 (0.66) [1.6]	17-3-D 0.7 (0.93) [1.6]		5-80 1.0 (1.33) [1.6]		5-80 1.0 (1.33) [1.6]
27-4-D 0.64 (0.85) [1.6]	12-2-D 0.5 (0.66) [1.6]	32-3-D 0.75 (1.0) [1.6]		23-1-D 2.0 (2.66) [3]		5-80 1.0 (1.33) [1.6]
28-4-D 0.78 (1.04) [1.6]	13-2-D 0.5 (0.66) [1.6]	12-4-D 0.5 (0.66) [1.6]		14-2-D 2.0 (2.66) [3]		15-2-D 0.8 (1.06) [1.6]
	16-4-D 0.9 (1.2) [1.6]	13-4-D 0.5 (0.66) [1.6]		15-2-D 0.8 (1.06) [1.6]		21-3-D 2.0 (2.66) [3]
	17-4-D 0.9 (1.2) [1.6]	14-4-D 0.5 (0.66) [1.6]		20-2-D 0.8 (1.06) [1.6]		17-88 1.5 (2.0) [2]
	2-80 19.2 (25.6) [25]	3-88 1.1 (1.46) [1.6]		17-88 1.5 (2.0) [2]		
	7-88 1.0 (1.33) [1.6]	8-88 1.0 (1.33) [1.6]				

TABLE B-2
(Continued)
DC LOAD LOCATIONS

L AV Rack		R AV Rack		Fwd Cargo Area	L Pod
1-1-D 1.0 (1.33) [1.6]	4-2-D 1.4 (1.86) [2]	6-8D 10 (13.3) [15]	7-3-D 1.4 (1.86) [2]	14-E-D 14.4 (19.2) [20]	5-1-D 0.6 (0.8) [1.6]
7-1-D 1.0 (1.33) [1.6]	5-2-D 0.73 (0.97) [1.6]	8-8D 13 (17.3) [20]	8-3-D 0.73 (0.97) [1.6]	12-E-D 3.9 (5.2) [7.5]	6-1-D 1.0 (1.33) [1.6]
8-1-D 2.0 (2.66) [3]	6-2-D 0.78 (1.04) [1.6]	13-8B 0.72 (0.96) [1.6]	9-3-D 0.78 (1.04) [1.6]		3-4-D 0.6 (0.8) [1.6]
9-1-D 1.9 (2.53) [3]	7-2-D 1.1 (1.46) [1.6]	15-8B 0.55 (0.73) [1.6]	10-3-D 11 (14.6) [15]		4-4-D 0.6 (0.8) [1.6]
12-1-D 1.5 (2.0) [2]	8-2-D 1.8 (2.4) [3]	19-1-D 0.62 (0.82) [1.6]	11-3-D 3.9 (5.2) [7.5]		5-4-D 1.0 (1.33) [1.6]
30-1-D 0.55 (0.73) [1.6]	2-E-D 4.2 (5.6) [7.5]		12-3-D 1.8 (2.4) [3]		1-E-D 1.5 (2.0) [2]
31-1-D 0.7 (0.93) [1.6]	3-E-D 3.5 (4.7) [5]		19-3-D 0.62 (0.82) [1.6]		
32-1-D 0.8 (1.1) [1.6]	4-E-D 2.1 (2.8) [3]		37-3-D 4.0 (5.3) [7.5]		
33-1-D 0.9 (1.2) [1.6]	7-E-D 4.2 (5.6) [7.5]		6-4-D 1.0 (1.33) [1.6]		
3-2-D 8.46 (13) [15]	10-E-D 7.0 (9.33) [10]		7-4-D 2.0 (2.66) [3]		
			7-4-D 1.0 (1.33) [1.6]		
			33-3-D 1.0 (1.33) [1.6]		
			33-3-D 1.0 (1.33) [1.6]		

TABLE B-2
(Continued)
DC LOAD LOCATIONS

R Pod	Eng #1	Eng #2	Aft Cargo Area
2-3-D 0.6 (0.8) [1.6]	25-1-D 3.0 (4.0) [5]	26-1-D 1.3 (1.73) [2]	18-2-D 3.0 (4.0) [5]
3-3-D 0.6 (0.8) [1.6]	26-1-D 1.2 (1.6) [1.6]	17-2-D 3.0 (4.0) [5]	19-2-D 3.0 (4.0) [5]
20-3-D 1.0 (1.33) [1.6]	28-1-D 1.5 (2.0) [2]	22-2-D 1.5 (2.0) [2]	25-3-D 3.0 (4.0) [5]
31-3-D 1.0 (1.33) [1.6]	29-1-D 0.8 (1.1) [1.6]	23-2-D 0.8 (1.1) [1.6]	26-3-D 3.0 (4.0) [5]
1-E-D 1.5 (2.0) [2]	36-1-D 0.5 (0.66) [1.6]	30-2-D 0.5 (0.66) [1.6]	9-4-D 1.1 (1.46) [1.6]
	37-1-D 0.8 (1.1) [1.6]	31-2-D 0.8 (1.1) [1.6]	14-E-D 7.2 (9.6) [10]
	38-1-D 1.2 (1.6) [1.6]	32-2-D 1.2 (1.6) [1.6]	12-E-D 3.9 (5.2) [7.5]
	39-1-D 1.0 (1.33) [1.6]	33-2-D 1.0 (1.33) [1.6]	
	40-1-D 2.5 (3.3) [5]	34-2-D 2.5 (3.3) [5]	
	41-1-D 1.2 (1.6) [1.6]	35-2-D 1.2 (1.6) [1.6]	
	42-1-0 1.0 (1.33) [1.6]	27-8B 1.0 (1.33) [1.6]	
	43-1-D 1.0 (1.33) [1.6]	28-8B 1.25 (1.6) [1.6]	
	44-1-0 0.7 (0.93) [1.6]	1-8D 19 (25.3) [25]	
	29-2-D 0.5 (0.66) [1.6]	46-3-D 1.0 (1.33) [1.6]	
	39-3-D 0.5 (0.66) [1.6]	47-3-D 1.0 (1.33) [1.6]	
	3-8D 8.0 (10.6) [15]	32-4-D 0.5 (0.66) [1.6]	
	4-8D 0.83 (1.1) [1.6]	3-8D 8.0 (10.6) [15]	
	12-8B 1.0 (1.33) [1.6]	4-8D 0.83 (1.1) [1.6]	
	26-8B 1.5 (2.0) [2]	12-8B 1.0 (1.33) [1.6]	
	27-8B 1.0 (1.33) [1.6]	26-8B 1.5 (2.0) [2]	

TABLE B-2
(Continued)
DC LOAD LOCATIONS

Eng #3	Eng #4	Tail
35-1-0 0.5 (0.66) [1.6]	20-4-0 1.3 (1.73) [2]	18-1-0 2.0 (2.66) [3]
27-3-0 1.5 (2.0) [2]	21-4-0 3.0 (4.0) [5]	20-1-0 1.0 (1.33) [1.6]
28-3-0 0.8 (1.1) [1.6]	23-4-0 1.5 (2.0) [2]	15-4-0 4.0 (5.33) [7.5]
40-3-0 0.5 (0.66) [1.6]	24-4-0 0.8 (1.1) [1.6]	2-88 1.1 (1.46) [1.6]
41-3-0 0.8 (1.1) [1.6]	31-4-0 0.5 (0.66) [1.6]	4-88 1.1 (1.46) [1.6]
42-3-0 1.2 (1.6) [1.6]	33-4-0 0.8 (1.1) [1.6]	3-80 8.0 (10.6) [15]
43-3-0 1.0 (1.33) [1.6]	34-4-0 1.2 (1.6) [1.6]	4-80 0.83 (1.18) [1.6]
44-3-0 2.5 (3.3) [5]	35-4-0 1.0 (1.33) [1.6]	9-80 190 (253) [300]
20-4-0 1.2 (1.6) [1.6]	36-4-0 2.5 (3.3) [5]	19-88 5.2 (6.9) [7.5]
3-80 8.0 (10.6) [15]	37-4-0 1.2 (1.6) [1.6]	20-88 5.0 (6.6) [7.5]
4-80 0.83 (1.1) [1.6]	38-4-0 1.0 (1.33) [1.6]	22-88 2.5 (3.33) [5]
12-88 1.0 (1.33) [1.6]	39-4-0 1.0 (1.33) [1.6]	23-88 0.5 (0.66) [1.6]
26-88 1.5 (2.0) [2]	3-80 8.0 (10.6) [15]	24-88 7.25 (9.66) [10]
27-88 1.0 (1.33) [1.6]	4-80 0.83 (1.1) [1.6]	
28-88 1.25 (1.6) [1.6]	12-88 1.0 (1.33) [1.6]	
24-3-0 3.0 (4.0) [5]	26-88 1.5 (2.0) [2]	
1-80 19 (25.3) [25]	27-88 1.0 (1.33) [1.6]	
	28-88 1.25 (1.6) [1.6]	
	1-80 19 (25.3) [25]	

APPENDIX C
AC SYSTEM PANEL AND LOAD SUMMARY

The SSPCs for AC loads from Appendix B are assigned to AC panel boards and the panel board currents and feeders are defined. Spares are provided on the basis of 25% of the SSPC/RCCB positions to be spares. Feeder capacity is provided for spares on the basis of the average current per SSPC to be the same for both active and spare SSPCs. Voltage drops in the feeders are designed to not exceed 1.0 volt per phase, thus allowing 3.0 volts drop per phase, maximum, for the load branch circuits. This design complies with the total distribution voltage drop of 4.0 volts per phase as specified in MIL-STD-704.

The following information defines the headings and codes used in the tables contained within this appendix:

1. Locations are self-explanatory.
2. Code 46-1-A indicates load serial number 46, Bus 1, on the AC system. This coding is described in more detail in Appendix A.
- 3: Current is the connected value in amperes; if composed of more than one discrete load, for example three loads, the number is shown thus: (3).
4. SSPC/RCCB is the selected unit trip rating for load protection (which is also capable of protecting the wire).
5. Load = sum of load currents; SSPC = sum of SSPC trip ratings; panel nominal current capacity allows current between the two, with 25% added for spare SSPCs, raised to next CB or wire rating value.
6. Three-phase load protection is symbolized by the designation 3 \emptyset , placed beside the SSPC/RCCB rating.
7. Loads having low power factor and stored energy characteristics are symbolized adjacent to the load identification code as follows:

M Motor Load
T Transformer Load
L Inductive Load-Solenoid
FL Inductive Load - Fluorescent Light

C Capacitive Load - Instrument
IG Ignition (Transformer or Induction Coil)
FC Flight Computer
IN Inertial Navigation System
P Power Supply
(1), (2), (3), & (4) Unit Numbers

TABLE C-1
AC SYSTEM PANEL AND LOAD SUMMARY
AC SYSTEM - BUS 1

<u>Location</u>	<u>Load Ident.</u>	<u>Current</u>	<u>SSPC/RCCB</u>	<u>Panel Feeder</u>		
				<u>Size</u>	<u>Capacity</u>	<u>Length</u>
<u>PANEL AC - INST - 1 (Sta 300-L)</u>						
Nose	None					
L Instr. Panel	33-1-A	0.87	1.6			
C Instr. Panel	42-1-A	0.30	0.5			
"	45-1-A	0.20	0.5			
"	46-1-A	0.20	0.5			
R Instr. Panel	34-1-A	0.87	1.6			
O'head Panel	None					
L Pedestal	36-1-A	1.0	1.6			
"	10-1-A	8.7	15			
Spares	<u>5 SSPCs</u>	<u>10</u>	<u>8</u>			
Totals	12 Units	22.1A	29.3A	AN-10	33A	18 Ft.
<u>PANEL AC - COCKPIT - 1 (Sta 400-L)</u>						
R EPC	2-1-A M	1.6	3			
"	7-1-A T	0.8	1.6			
"	9-1-A T	4.8	7.5			
"	17-1-A	12	20			
"	18-1-A	6.6	10			
"	39-1-A	0.6	1.6			
"	19-1-A	6.6	10			
L Avionics Rack	1-1-A M	7.3	15 30			
"	37-1-A	0.9	1.6			
"	38-1-A	0.9	1.6			
Lower L EPC	8-1-A T	0.9	1.6			
Spares	<u>5 SSPCs</u>	<u>20</u>	<u>25</u>			
Totals	16 Units	59.1A	98.5A	AN-4	80A	10 Ft.

TABLE C-1
(Continued)
AC SYSTEM - BUS 1

<u>Location</u>	<u>Load Ident.</u>	<u>Current</u>	<u>SSPC/RCCB</u>	<u>Panel Feeder</u>		
				<u>Size</u>	<u>Capacity</u>	<u>Length</u>
<u>PANEL AC - FWD-CARGO - 1 (Sta 600-L)</u>						
Fwd Cargo	5-1-A M	13.6	20 3Ø			
"	23-1-A	4.5(3)	7.5			
"	26-1-A	0.9	1.6			
"	29-1-A	3.9(3)	7.5			
"	30-1-A	4.8	7.5			
Spares	<u>3 SSPCs</u>	<u>15A</u>	<u>15</u>			
Totals	8 Units	42.7A	59.1A	AN-6	60A	18 Ft.
<u>PANEL AC - WING/ENGINE - 1 (Sta 800L)</u>						
Outbd Engine	12-1-A M	7.0	10 3Ø			
"	13-1-A M	7.0	10 3Ø			
Inbd Engine	14-1-A M	7.0	10 3Ø			
Outbd Engine	15-1-A	1.2	1.6			
Tip	21-1-A	0.7	1.6			
"	27-1-A	0.87	1.6			
"	28-1-A	5.2	7.5			
"	25-1-A (1)	0.43	0.5			
Trail Edge	25-1-A (1)	0.43	0.5			
L Pod	4-1-A M	1.6	3			
"	20-1-A L	3	5			
"	24-1-A	7.8	10			
R Pod	16-1-A M	65	100 3Ø			
Engine 2	47-1-A	1.2	1.6			
Engine 3	41-1-A	1.2	1.6			
Spares	<u>5 SSPCs</u>	<u>35A</u>	<u>50A</u>			
Totals	20 Units	130.6A	194.5A	AN-2/0	175A	35 Ft.
<u>PANEL AC - AFT CARGO - 1 (Sta 1000L)</u>						
Aft Cargo	29-1-A	3.9 (3)	7.5			
"	23-1-A FL	4.5 (3)	7.5			
"	32-1-A	1.7 (2)	3			
Tail	22-1-A	5.4 (3)	7.5			
"	31-1-A	5.2 (2)	7.5			
Spares	<u>3 SSPCs</u>	<u>12A</u>	<u>15A</u>			
Totals	8 Units	32.7A	48A	AN-8	46A	52 Ft.

TABLE C-2
AC SYSTEM PANEL AND LOAD SUMMARY
AC SYSTEM - BUS 2

<u>Location</u>	<u>Load Ident.</u>	<u>Current</u>	<u>SSPC/RCCB</u>	<u>Panel Feeder</u>		
				<u>Size</u>	<u>Capacity</u>	<u>Length</u>
<u>PANEL AC - INST - 2 (Sta 300-L)</u>						
Nose	29-2-A	2.9	5			
"	30-2-A	3.8	5			
L Instr. Panel	33-2-A	0.1	0.5			
C Instr. Panel	2-2-A	0.3	0.5			
"	18-2-A	0.1	0.5			
L Pedestal	38-2-A	1.3	2			
"	31-2-A M	1.1	1.6 3Ø			
"	32-2-A M	1.1	1.6 3Ø			
Spares	<u>4 SSPCs</u>	<u>6.4</u>	<u>8</u>			
Totals	12 Units	17.1A	24.7A	AN-12	23A	18 Ft.
<u>PANEL AC - COCKPIT - 2 (Sta 400-L)</u>						
L EPC	13-2-A T	0.8	1.6			
"	14-2-A T	5.5	7.5 3Ø			
"	25-2-A	6.6	10			
"	26-2-A	6.6	10			
"	27-2-A	6.6	10			
"	42-2-A	0.6	1.6			
L Avionics Rack	3-2-A FC	1.3	2			
"	4-2-A FC	0.77	1.2			
"	5-2-A FC	2	3			
"	6-2-A FC	1.8	3			
"	8-2-A	0.9	1.6			
"	15-2-A	0.7	1.6			
"	35-2-A FC	1.9	3			
"	39-2-A	2	3			
"	40-2-A	2.6	5			
"	41-2-A FC	1.2	1.6			
"	1-2-A M	7.3	15 3Ø			
Lower L EPC	None					
Spares	<u>7 SSPCs</u>	<u>18.6</u>	<u>33.4</u>			
Totals	24 Units	63.7A	114.5A	AN-2	100A	10 Ft.

TABLE C-2
 (Continued)
 AC SYSTEM - BUS 2

<u>Location</u>	<u>Load Ident.</u>	<u>Current</u>	<u>SSPC/RCCB</u>	<u>Panel Feeder</u>		
				<u>Size</u>	<u>Capacity</u>	<u>Length</u>
<u>PANEL AC - WING/ENGINE - 2 (Sta 800-L)</u>						
C Wing Box	19-2-A M	7	10 3Ø			
L Wing Outbd	20-2-A (1) M	7	10 3Ø			
"	21-2-A (2) M	7	10 3Ø			
L Wing Inbd	22-2-A M	7	10 3Ø			
"	23-2-A	1.2	1.6			
Leading Edge	16-2-A M	3.3	5			
L Pod	24-2-A M	65	100 3Ø			
Engine 4	44-2-A	1.2	1.6			
Spares	<u>4 SSPCs</u>	<u>49.4</u>	<u>74</u>			
Totals	12 Units	148.1A	222.2A	AN-3/O	200A	35 Ft.

TABLE C-3
AC SYSTEM PANEL AND LOAD SUMMARY
AC SYSTEM - BUS 3

<u>Location</u>	<u>Load Ident.</u>	<u>Current</u>	<u>SSPC/RCCB</u>	<u>Panel Feeder</u>		
				<u>Size</u>	<u>Capacity</u>	<u>Length</u>
<u>PANEL AC - INST - 3 (Sta 300-R)</u>						
Nose	30-3-A	3.8	5			
"	31-3-A	7.6 (2)	10			
"	32-3-A	2.9	5			
"	33-3-A	3.8	5			
"	50-3-A	3	5			
C Instr. Panel	2-3-A	0.3	0.5			
R Instr. Panel	36-3-A	0.26	0.5			
"	37-3-A	0.1	0.5			
R Pedestal	34-3-A M	1.1	1.6	3Ø		
"	35-3-A M	1.1	1.6	3Ø		
Spares	<u>6 SSPCs</u>	<u>12</u>	<u>18</u>			
Totals	16 Units	46.3A	52.7A	AN-6	60A	18 Ft.
<u>PANEL AC - COCKPIT - 3 (Sta 400-R)</u>						
R EPC	13-3-A T	0.8	1.6			
"	14-3-A T	5.6	7.5			
"	15-3-A	1.0	1.6			
"	27-3-A	6.6	10			
"	28-3-A	6.6	10			
"	29-3-A	6.3	10			
"	47-3-A	0.6	1.6			
R Avionics Rack	3-3-A FC	1.3	2			
"	4-3-A FC	0.77	1.6			
"	5-3-A FC	2	3			
"	6-3-A FC	1.8	3			
"	12-3-A	4	7.5			
"	16-3-A	0.7	1.6			
"	38-3-A	5.4	7.5			
"	39-3-A	2.7	5			
"	40-3-A	1.4	2			
"	1-3-A M	2.3	15	3Ø		
"	42-3-A FC	1.9	3			
"	43-3-A IN	6	10			
"	44-3-A	9.4	15			
"	46-3-A	2.6	5			

TABLE C-3
(Continued)
AC SYSTEM - BUS 3

<u>Location</u>	<u>Load Ident.</u>	<u>Current</u>	<u>SSPC/RCCB</u>	<u>Panel Feeder</u>		
				<u>Size</u>	<u>Capacity</u>	<u>Length</u>
Lower L Avionics	9-3-A T	5.5	7.5	3Ø		
"	10-3-A	1.56	3			
Spares	5 SSPCs	15	25			
Totals	28 Units	96.5A	159A	AN-1	125A	10 Ft.
<u>PANEL AC - WING/ENGINE - 3 (Sta 800-R)</u>						
Fwd Cargo Area	8-3-A	0.7	1.6			
"	41-3-A T	0.83	1.6			
Ctr Wing Box	21-3-A M	7	10	3Ø		
R Wing Lead Edge	18-3-A M	3.3	5			
Outboard	22-3-A M	7	10	3Ø		
Inboard	23-3-A M	7	10	3Ø		
"	24-3-A M	7	10	3Ø		
"	25-3-A	1.2	1.6			
R Pod	26-3-A M	65	100	3Ø		
Engine 1	49-3-A	1.2	1.6			
Tail	11-3-A	1.4	2			
"	17-3-A M	4.7	1.6			
Spares	4 SSPCs	32	52			
Totals	16 Units	124.3A	207A	AN-2/0	175A	35 Ft.

TABLE C-4
AC SYSTEM PANEL AND LOAD SUMMARY
AC SYSTEM - BUS 4

Location	Load Ident.	Current	SSPC/RCCB	Panel Feeder		
				Size	Capacity	Length
<u>PANEL AC - INST - 1 (Sta 300-R)</u>						
C Instr. Panel	45-4-A	0.4	0.5			
"	48-4-A	0.2 (2)	0.5			
R Instr. Panel	36-4-A	1	1.6			
"	38-4-A	0.15	0.5			
O'head Panel	37-4-A	0.8	1.6			
Pedestal	35-4-A	0.8	1.6			
R Pedestal	39-4-A	1	1.6			
"	10-4-A	8.7	15			
Spares	<u>4 SSPCs</u>	<u>6.4</u>	<u>8</u>			
Totals	12 Units	19.7A	30.9A	AN-10	33A	18 Ft.
<u>PANEL AC - COCKPIT - 4 (Sta 400-R)</u>						
R EPC	6-4-A T	0.8	1.6			
"	8-4-A T	19	25	3Ø		
"	17-4-A	12	20			
"	18-4-A	6.6	10			
"	19-4-A	6.6	10			
"	42-4-A	0.6	1.6			
R Avionics Rack	3-4-A	1.3	2			
"	40-4-A	0.9	1.6			
"	41-4-A	0.9	1.6			
"	1-4-A M	7.3	10	3Ø		
Spares	<u>6 SSPCs</u>	<u>30</u>	<u>48</u>			
Totals	16 Units	86.8A	131.4A	AN-2	100A	10 Ft.
<u>PANEL AC - FWD CARGO - 4 (Sta 600-R)</u>						
Fwd Cargo	2-4-A M	7.3	10	3Ø		
"	5-4-A M	13.6	20	3Ø		
"	9-4-A M	16	25	3Ø		
"	25-4-A FL	4.5 (3)	7.5			
"	28-4-A	0.9	1.6			
"	31-4-A	3.9 (3)	7.5			
"	32-4-A	4.8	7.5			
Spares	<u>5 SSPCs</u>	<u>40</u>	<u>55</u>			
Totals	12 Units	91A	134.1A	AN-1	125A	18 Ft.

TABLE C-4
(Continued)
AC SYSTEM - BUS 4

<u>Location</u>	<u>Load Ident.</u>	<u>Current</u>	<u>SSPC/RCCB</u>	<u>Panel Feeder</u>		
				<u>Size</u>	<u>Capacity</u>	<u>Length</u>
<u>PANEL AC - WING/ENGINE - 4 (Sta 800-R)</u>						
R Wing - Outbd	12-4-A M	7	10	3Ø		
"	13-4-A M	7	10	3Ø		
Inboard	14-4-A M	7	10	3Ø		
Outboard	15-4-A	1.2	1.6			
Tip	22-4-A	0.7	1.6			
"	29-4-A	0.87	1.6			
"	30-4-A	5.2	7.5			
Tip & Trail Edge	27-4-A	0.87 (2)	1.6			
R Pod	4-4-A M	1.6	3			
"	16-4-A M	65	100	3Ø		
"	21-4-A L	3	5			
Ldg Gear Door	26-4-A	7.8	10			
Engine 2	44-4-A	1.2	1.6			
Engine 3	20-4-A	1.2	1.6			
Spares	<u>6 SSPCs</u>	<u>48</u>	<u>72</u>			
Totals	20 Units	157.7A	237.1A	AN-3/0	200A	35 Ft.
<u>PANEL AC - AFT CARGO - 4 (Sta 1000-R)</u>						
Aft Cargo	9-4-A	16	25			
"	23-4-A	5.4 (3)	7.5			
"	25-4-A	4.5 (3)	7.5			
"	31-4-A	3.9 (3)	7.5			
"	34-4-A	1.7 (2)	3			
Tail	24-4-A	1.8	3			
"	33-4-A	5.2 (3)	7.5			
Spares	<u>5 SSPCs</u>	<u>25</u>	<u>45</u>			
Totals	12 Units	63.5A	106A	AN-4	80A	52 Ft.

TABLE C-5
AC SYSTEM PANEL AND LOAD SUMMARY
AC SYSTEM - EMERGENCY BUS

<u>Location</u>	<u>Load Ident.</u>	<u>Current</u>	<u>SSPC/RCCB</u>	<u>Panel Feeder</u>		
				<u>Size</u>	<u>Capacity</u>	<u>Length</u>
<u>PANEL AC - EMERG - E (Sta 375)</u>						
Nose	14-E-A	3.8	5			
L Instr. Panel	4-E-A	0.15	0.5			
"	15-E-A	0.26	0.5			
C Instr. Panel	3-E-A C	0.1	0.5			
"	6-E-A	0.4 (4)	0.5			
"	7-E-A	0.4 (4)	0.5			
"	13-E-A C	0.13	0.5			
L EPC	2-E-A T	1.3	2			
R EPC	24-E-A T	4.8	7.5 30			
C Instr Panel	20-E-A C	0.13	0.5			
"	21-E-A C	0.13	0.5			
"	25-E-A C	0.1	0.5			
"	27-E-A	0.4 (4)	0.5			
"	28-E-A	0.4 (4)	0.5			
L Avionics Rack	1-E-A	1.3	2			
"	8-E-A FC	1.6	3			
"	16-E-A IN	6	10			
"	17-E-A	9.4	15			
R Avionics Rack	19-E-A FC	1.6	3			
"	22-E-A FC	1.2	1.6			
Lower Av Rack	10-E-A T	5.5	10 30			
"	11-E-A	1.56	3			
Engine 1	5-E-A IG	1.3	2			
Engine 2	18-E-A IG	1.3	2			
Engine 3	23-E-A IG	1.3	2			
Engine 4	26-E-A IG	1.3	2			
Tail	9-E-A	0.8	1.6			
"	12-E-A	1.4	2			
Spares	<u>8 SSPCs</u>	<u>13.7</u>	<u>22.6</u>			
Totals	36 Units	61.8A	101.8A	AN-2	100A	12 Ft.

APPENDIX D
DC SYSTEM PANEL AND LOAD SUMMARY

The SSPCs for DC loads from Appendix B are assigned to DC panel boards and the panel board currents and feeders are defined. Spares are provided on the basis of 25% of the SSPC/RCCB positions to be spares. Feeder capacity is provided for spares on the basis of the average current per SSPC to be the same for both active and spares SSPCs. Voltage drops in the feeders are designed not to exceed 0.5 volt, thus allowing 1.5 volt drop maximum, for the load branch circuits. This design complies with the total distribution voltage drop of 2.0 volts as specified in MIL-STD-704.

The following information defines the headings and codes used in the tables contained within this appendix:

1. Locations are self-explanatory.
2. Code 26-2-D indicates load serial number 26, Bus 2, on the DC system. This coding is described in more detail in Appendix A.
3. Current is the connected value in amperes: if composed of more than one discrete load, for example three loads, the number is shown thus: (3).
4. SSPC/RCCB is the selected trip rating for load protection (which is also capable of protecting the wire).
5. Load = sum of load currents: SSPC = sum of SSPC trip ratings: panel nominal current capacity allows current between the two, with 25% added for spare SSPCs, raised to next CB or wire rating value.
6. Loads are symbolized adjacent to the load identification code as follows:

M Motor Load
L Inductive Load-Solenoid
FC Flight Computer
P Power Supply
(1), (2), (3), & (4) Unit Numbers

TABLE D-1
DC SYSTEM PANEL AND LOAD SUMMARY
DC SYSTEM - BUS 1

Location	Load Ident.	Current	SSPC/RCCB	Panel Feeder		
				Size	Capacity	Length
<u>PANEL DC - INST -1 (Sta 300-L)</u>						
C Instr Panel	17-1-D	0.08	0.5			
L Instr Panel	27-1-D M	9.0	15			
Ovhd Panel	2-1-D	0.44	1.6			
"	3-1-D	0.09	0.5			
"	4-1-D	0.27 (3)	0.5			
"	13-1-D	0.05	0.5			
"	22-1-D	0.05	0.5			
"	24-1-D	0.07	0.5			
"	45-1-D	0.05	0.5			
"	34-1-D	0.07	0.5			
Pedestal	10-1-D	2.6	5			
"	11-1-D	1.1	2			
Spares	<u>4 SSPC</u>	<u>4.6</u>	<u>9.2</u>			
Totals	16 Units	18.5A	36.8A	AN-10 (*)	33A	18 Ft.

(*) Allowable dc voltage drop for Cat. B equipment is 2.0 volts. This is allocated with 0.5V in panel feeder and 1.5 in load branch circuit. The dc feeders may therefore be sized by voltage drop rather than by current requirement.

PANEL DC - COCKPIT -1 (Sta 400-L)

L EPC	14-1-D L	0.5	1.6			
"	15-1-D L	0.5	1.6			
"	16-1-D L	0.5	1.6			
"	21-1-D	1.75	3			
L Avionics Rack	1-1-D	1	1.6			
"	7-1-D FC	1	1.6			
"	8-1-D FC	2	3			
"	9-1-D	1.9	3			
"	12-1-D	1.5	2			
"	30-1-D	0.55	1.6			
"	31-1-D	0.7	1.6			
"	32-1-D	0.8	1.6			
"	33-1-D	0.9	2			
"	19-1-D M	0.62	1.6			
Spares	<u>6 SSPC</u>	<u>6.1</u>	<u>11.7</u>			
Totals	20 Units	20.4A	39.1A	AN-12	23A	10 Ft.

TABLE D-1
(Continued)
DC SYSTEM - BUS 1

<u>Location</u>	<u>Load Ident.</u>	<u>Current</u>	<u>SSPC/RCCB</u>	<u>Panel Feeder</u>		
				<u>Size</u>	<u>Capacity</u>	<u>Length</u>
<u>PANEL DC - WING/ENGINE -1 (Sta 800-L)</u>						
L Wing Outbd	23-1-D M	2	3			
L Pod	5-1-D L	0.6	1.6			
"	6-1-D L	1	1.0			
Eng 1	25-1-D M	3	5			
"	26-1-D L	1.2	1.6			
"	28-1-D L	1.5	2			
"	29-1-D L	0.8	1.6			
"	36-1-D L	0.5	1.6			
"	37-1-D L	0.8	1.6			
"	38-1-D L	1.2	1.6			
"	39-1-D L	1	1.6			
"	40-1-D L	2.5	3			
"	41-1-D L	1.2	1.6			
"	42-1-D M	1	1.6			
"	43-1-D M	1	1.6			
"	44-1-D L	0.7	1.6			
Eng 2	26-1-D L	1.3 (2)	2			
Eng 3	35-1-D L	0.5	1.6			
Spares	<u>6 SSPC</u>	<u>7.3</u>	<u>11.2</u>			
Totals	24 Units	29.1A	44.8A	AN-6	60A	35 Ft.
<u>PANEL DC - AFT CARGO -1</u>						
Tail	18-1-D M	2	3			
"	20-1-D M	1	1.6			
Spares	<u>2 SSPC</u>	<u>3</u>	<u>4.6</u>			
Totals	4 Units	6.0A	9.2A	AN-10	33A	52 Ft.

TABLE D-2
DC SYSTEM PANEL AND LOAD SUMMARY
DC SYSTEM - BUS 2

<u>Location</u>	<u>Load Ident.</u>	<u>Current</u>	<u>SSPC/RCCB</u>	<u>Panel Feeder</u>		
				<u>Size</u>	<u>Capacity</u>	<u>Length</u>
<u>PANEL DC - INST -1 (Sta 300-L)</u>						
L Instr Panel	21-2-D L	1.5	2			
Ovhd Panel	9-2-D	0.05	0.5			
"	10-2-D	0.3	0.5			
"	16-2-D	0.07	0.5			
"	39-2-D	0.04	0.5			
"	24-2-D	1	1.6			
"	28-2-D	0.07	0.5			
Pedestal	2-2-D	0.8	1.6			
"	26-2-D	0.51	1.6			
"	27-2-D	0.51	1.6			
(L. Stick)	1-2-D M	0.5	1.6			
Spares	<u>5 SSPC</u>	<u>2.4</u>	<u>5.7</u>			
Totals	16 Units	7.8A	18.2A	AN-14	17A	18 Ft.
<u>PANEL DC - COCKPIT -1 (Sta 400-L)</u>						
L EPC	11-2-D L	0.5	1.6			
"	12-2-D L	0.5	1.6			
"	13-2-D L	0.5	1.6			
L Avionics Rack	3-2-D FC	8.46	15			
"	4-2-D FC	1.4	1.6			
"	5-2-D FC	0.73	1.6			
"	6-2-D FC-P	0.78	1.6			
"	7-2-D	1.1	1.6			
"	8-2-D	1.8	3			
Spares	<u>3 SSPC</u>	<u>8.3</u>	<u>9.7</u>			
Totals	12 Units	21.0A	38.9A	AN-12	23A	10 Ft.

TABLE D-2
(Continued)
DC SYSTEM - BUS 2

Location	Load Ident.	Current	SSPC/RCCB	Panel Feeder		
				Size	Capacity	Length
<u>PANEL DC - WING/ENGINE - 2 (Sta 800-L)</u>						
L Wing Inbd	14-2-D M	2	3			
L Wing Fwd Center	15-2-D L	0.8	1.6			
L Wing Lead Edge	20-2-D L	0.8	1.6			
R Wing Fwd Center	15-2-D	0.8	1.6			
Eng 1	29-2-D L	0.5	1.6			
Eng 2	17-2-D M	3	5			
"	22-2-D L	1.5	2			
"	23-2-D L	0.8	1.6			
"	30-2-D L	0.5	1.6			
"	31-2-D L	0.8	1.6			
"	32-2-D L	1.2	1.6			
"	33-2-D L	1	1.6			
"	34-2-D L	2.5	5			
"	35-2-D L	1.2	1.6			
"	36-2-D M	1	1.6			
"	37-2-D M	1	1.6			
"	38-2-D L	0.7	1.6			
Spares	<u>7 SSPC</u>	<u>8.3</u>	<u>14.7</u>			
Totals	24 Units	28.4A	50.5A	AN-6	60A	35 Ft.
<u>PANEL DC - AFT CARGO - L (Sta 1000-L)</u>						
Aft Cargo	18-2-D M	3 (2)	5			
"	19-2-D M	3 (2)	5			
Spares	<u>2 SSPC</u>	<u>6</u>	<u>10</u>			
Totals	4 Units	12.0A	20A	AN-8	46A	52 Ft.

TABLE D-3
DC SYSTEM PANEL AND LOAD SUMMARY
DC SYSTEM - BUS 3

<u>Location</u>	<u>Load Ident.</u>	<u>Current</u>	<u>SSPC/RCCB</u>	<u>Panel Feeder</u>		
				<u>Size</u>	<u>Capacity</u>	<u>Length</u>
<u>PANEL DC - INST -3 (Sta 300-R)</u>						
C Instr Panel	18-3-D	0.1	0.5			
"	5-3-D	0.5	1.6			
"	30-3-D	0.64	1.6			
Ovhd Panel	1-3-D	0.04	0.5			
"	13-3-D	0.05	0.5			
"	22-3-D	0.7	1.6			
"	48-3-D	0.05	0.5			
"	38-3-D	0.07	0.5			
Pedestal (R Stick)	4-3-D M	0.5	1.6			
Spares	3 SSPC	0.9	3.0			
Totals	12 Units	3.6A	11.9A	AN-18	10A	18 Ft.
<u>PANEL DC - COCKPIT -3 (Sta 400-R)</u>						
Cockpit	34-3-D	0.64	1.6			
"	35-3-D	0.64	1.6			
"	36-3-D	0.64	1.6			
R EPC	14-3-D L	0.5	1.6			
"	15-3-D L	0.5	1.6			
"	16-3-D L	0.5	1.6			
"	17-3-D L	0.7	1.6			
"	32-3-D	0.75	1.6			
R Avionics Rack	7-3-D FC	1.4	1.6			
"	8-3-D FC	0.73	1.6			
"	9-3-D FC-P	0.78	1.6			
"	10-3-D	11	15			
"	11-3-D	3.9	5			
"	12-3-D	1.8	3			
"	19-3-D	0.67	1.6			
"	37-3-D	4	5			
"	6-3-D FC	8.46	15			
"	33-3-D	1	2			
Spares	6 SSPC	12.9	21.4			
Totals	24 Units	51.5A	85.6A	AN-8	46A	10 Ft.

TABLE D-3
(Continued)
DC SYSTEM - BUS 3

Location	Load Ident.	Current	SSPC/RCCB	Panel Feeder		
				Size	Capacity	Length
<u>PANEL DC - WING/ENGINE - 3 (Sta 800-R)</u>						
R Wing Lead Edge	29-3-D L	0.8	1.6			
Outboard	21-3-D M	2	3			
R Pod	2-3-D L	0.6	1.6			
"	3-3-D L	0.6	1.6			
"	20-3-D M	1	1.6			
"	31-3-D	1	1.6			
Eng 1	39-3-D L	0.5	1.6			
Eng 2	46-3-D M	1	1.6			
"	47-3-D M	1	1.6			
Eng 3	27-3-D L	1.5	2			
"	28-3-D L	0.8	1.6			
"	40-3-D L	0.5	1.6			
"	41-3-D L	0.8	1.6			
"	42-3-D L	1.2	1.6			
"	43-3-D L	1	1.6			
"	44-3-D L	2.5	3			
"	45-3-D L	1.2	1.6			
"	24-3-D M	3	5			
Spares	<u>6 SSPC</u>	<u>7.0</u>	<u>12.3</u>			
Totals	24 Units	28.0A	47.7A	AN-6	60A	35 Ft.
<u>PANEL DC - AFT CARGO - 3 (Sta 1000-R)</u>						
Aft Cargo	25-3-D M	3 (2)	5			
"	26-3-D M	3	5			
Spares	<u>2 SSPC</u>	<u>6</u>	<u>10</u>			
Totals	4 Units	12.0A	20A	AN-8	46A	52 Ft.

TABLE D-4
DC SYSTEM PANEL AND LOAD SUMMARY
DC SYSTEM - BUS 4

<u>Location</u>	<u>Load Ident.</u>	<u>Current</u>	<u>SSPC/RCCB</u>	<u>Panel Feeder</u>		
				<u>Size</u>	<u>Capacity</u>	<u>Length</u>
<u>PANEL DC - INSTR - 4 (Sta 300-R)</u>						
R Instr Panel	22-4-D M	9	15			
"	25-4-D L	1.5	2			
Ovhd Panel	2-4-D	0.44	1			
"	19-4-D	0.07	0.5			
"	40-4-D	0.05	0.5			
"	41-4-D	0.05	0.5			
"	26-4-D	0.6	1.6			
"	30-4-D	0.07	0.5			
Spares	4 SSPC	5.9	10.8			
Totals	12 Units	17.7A	32.4A	AN-10	33A	18 Ft.
<u>PANEL DC - COCKPIT - 4 (Sta 400-R)</u>						
Cockpit	27-4-D	0.64	1.6			
"	28-4-D	0.78	1.6			
L EPC	16-4-D L	0.9	1.6			
"	17-4-D L	0.9	1.6			
R EPC	12-4-D L	0.5	1.6			
"	13-4-D L	0.5	1.6			
"	14-4-D L	0.5	1.6			
R Avionics Rack	6-4-D FC	1	1.6			
"	7-4-D FC	2	3			
"	8-4-D	2	3			
"	10-4-D	1.5	3			
"	11-4-D	3.9	5			
"	6-3-D	8.46	15			
"	29-4-D	0.5	1.6			
"	1-4-D	1	1.6			
Spares	5 SSPC	8.4	15.0			
Totals	20 Units	33.5A	60.0A	AN-10	33A	10 Ft.

TABLE D-4
(Continued)
DC SYSTEM - BUS 4

Location	Load Ident.	Current	SSPC/RCCB	Panel Feeder		
				Size	Capacity	Length
<u>PANEL DC - WING/ENGINE -4 (Sta 800-R)</u>						
R Wing Outboard	18-4-D M	2	3			
L Pod	3-4-D M	0.6	1.6			
"	4-4-D L	0.6	1.6			
"	5-4-D L	1	1.6			
Eng 2	32-4-D L	0.5	1.6			
Eng 3	20-4-D (3)-L	1.2	1.6			
Eng 4	20-4-D (4)-L	1.3	2			
"	21-4-D M	3	5			
"	23-4-D M	1.5	2			
"	24-4-D M	0.8	1.6			
"	31-4-D L	0.5	1.6			
"	33-4-D L	0.8	1.6			
"	34-4-D L	1.2	1.6			
"	35-4-D L	1	1.6			
"	36-4-D L	2.5	5			
"	37-4-D L	1.2	1.6			
"	38-4-D M	1	1.6			
"	39-4-D M	1	1.6			
Spares	<u>6 SSPC</u>	<u>7.2</u>	<u>12.6</u>			
Totals	24 Units	28.9A	50.4A	AN-6	60A	35 Ft.
<u>PANEL DC - AFT CARGO - 4</u>						
Aft Cargo	9-4-D	1.1	2			
"	15-4-D M	4	7.5			
Spares	<u>2 SSPC</u>	<u>5.1</u>	<u>9.5</u>			
Totals	4 Units	10.2A	19.0A	AN-8	46A	52 Ft.

TABLE D-5
DC SYSTEM PANEL AND LOAD SUMMARY
DC SYSTEM - EMERGENCY BUS

<u>Location</u>	<u>Load Ident.</u>	<u>Current</u>	<u>SSPC/RCCB</u>	<u>Panel Feeder</u>		
				<u>Size</u>	<u>Capacity</u>	<u>Length</u>
<u>PANEL DC - INST - E (Sta 300)</u>						
R Instr Panel	13-E-D	0.68	1.6			
C Instr Panel	13-E-D	0.68	1.6			
L Instr Panel	13-E-D	0.68	1.6			
L Pedestal	5-E-D	0.7	1.6			
R Pedestal	5-E-D	0.7	1.6			
"	6-E-D	1	1.6			
Spares	<u>2 SSPC</u>	<u>1.5</u>	<u>3.2</u>			
Totals	8 Units	5.9A	12.8A	AN-14	17A	18 Ft.
<u>PANEL DC - COCKPIT - E (Sta 400)</u>						
L Avionics Rack	2-E-D FC	4.2	5			
"	3-E-D FC	3.5	5			
"	4-E-D	2.1	3			
"	7-E-D	4.2	5			
"	10-E-D	7	10			
R Avionics Rack	8-E-D	1.7	2			
"	9-E-D	3.8	5			
"	16-E-D	0.8	2			
Spares	<u>4 SSPC</u>	<u>13.7</u>	<u>18.5</u>			
Totals	12 Units	41.0A	55.5A	AN-10	33A	10 Ft.
<u>PANEL DC - WING/ENGINE - E (Sta 800)</u>						
L Wing Center (Tank 2)	11-E-D (2) L	0.77	1.6			
L Wing Inboard (Tank 1)	11-E-D (1) L	0.77	1.6			
R Wing Inboard (Tank 3)	11-E-D (3) L	0.77	1.6			
L Pod	1-E-D L	1.5 (2)	2			
R Pod	1-E-D L	1.5 (2)	2			
Fwd Cargo Area	14-E-D	19.2 (4)	20			
"	12-E-D	3.9 (3)	7.5			
Aft Cargo Area	14-E-D	7.2 (2)	10			
"	12-E-D	3.9 (3)	7.5			
Spares	<u>3 SSPC</u>	<u>13.2</u>	<u>17.9</u>			
Totals	12 Units	52.7A	71.7A	AN-2	100A	35 Ft.

TABLE D-6
DC SYSTEM PANEL AND LOAD SUMMARY
DC SYSTEM - BATTERY BUS

<u>Location</u>	<u>Load Ident.</u>	<u>Current</u>	<u>SSPC/RCCB</u>	<u>Panel Feeder</u>		
				<u>Size</u>	<u>Capacity</u>	<u>Length</u>
<u>PANEL DC - INST - BB (Sta 300)</u>						
R Pedestal	1-BB	1.1	1.6			
L Pedestal	5-BB	1.1	1.6			
"	18-BB	10	15			
Ovhd Panel	14-BB	0.7	1.6			
"	16-BB	0.32	0.5			
Spares	<u>3 SSPC</u>	<u>7.9</u>				
Totals	8 Units	23.2A		AN-10	33A	18 Ft.
<u>PANEL DC - COCKPIT - BB (Sta 400)</u>						
Cockpit	9-BB L	1.0	1.6			
L EPC	7-BB	1.0 (2)	1.6			
"	25-BB	0.5	1.6			
R EPC	3-BB	1.1	1.6			
"	8-BB	1.0 (2)	1.6			
L EPC (Lower)	6-BB	32.4	50			
"	21-BB L	0.8	1.6			
L Avionics Rack	13-BB	0.72	1.6			
"	15-BB	0.55	1.6			
Spares	<u>3 SSPC</u>	<u>13.0</u>				
Totals	12 Units	52.0A		AN-6	60A	10 Ft.
<u>PANEL DC - WING/ENGINE - BB (Sta 800)</u>						
L Wing	17-BB L	1.5 (3)	2			
R Wing	17-BB L	1.5 (3)	2			
C Wing	10-BB L	1.0	1.6			
"	11-BB M	4.75	7.5			
Eng 1	12-BB (1) L	1.0	1.6			
"	26-BB (1) L	1.5	2			
"	27-BB (1) L	1.0	1.6			
"	28-BB (1) L	1.25	1.6			
Eng 2	12-BB (2) L	1.0	1.6			
"	26-BB (2) L	1.5	2.0			
"	27-BB (2) L	1.0	1.6			
"	28-BB (2) L	1.25	1.6			

TABLE D-6
(Continued)
DC SYSTEM - BATTERY BUS 3

Location	Load Ident.	Current	SSPC/RCCB	Panel Feeder		
				Size	Capacity	Length
Eng 3	12-BB (3) L	1.0	1.6			
"	26-BB (3) L	1.5	2.			
"	27-BB (3) L	1.0	1.6			
"	28-BB (3) L	1.25	1.6			
Eng 4	12-BB (4) L	1.0	1.6			
"	26-BB (4) L	1.5	2			
"	27-BB (4) L	1.0	1.6			
"	28-BB (4) L	1.25	1.6			
Spares	8 SSPC	11.1	16.2			
Totals	28 Units	38.9A	56.6A	AN-4	80A	35 Ft.

PANEL DC - AFT CARGO - BB (Sta 1000)

Tail	2-BB	1.1	1.6			
"	4-BB	1.1	1.6			
"	19-BB M	5.2	7.5			
"	20-BB M	5	7.5			
"	22-BB L	2.5 (2)	5			
"	23-BB L	0.5	1.6			
"	24-BB	7.25	10			
Spares	5 SSPC	16.2	24.9			
Totals	12 Units	38.8A	59.7A	AN-4*	80A	52 Ft.

*AN-0 (150A) feeder would be required for 0.5V feeder drop, if the full spare allocation is used. AN-4 would give 0.7V drop, allowing 1.3V drop in load branch circuits. The latter is preferred.

TABLE D-7
DC SYSTEM PANEL AND LOAD SUMMARY
DC SYSTEM - BATTERY DIRECT BUS

Location	Load Ident.	Current	SSPC/RCCB	Panel Feeder		
				Size	Capacity	Length
<u>PANEL DC - COCKPIT - BD (Sta 400)</u>						
L EPC	2-BD	19.2	25			
L Avionics Rack	6-BD	10	15			
"	8-BD	13	20			
R Avionics Rack	7-BD	10	15			
Spares	4 SSPC	39.2	70			
Totals	8 Units	78.4A	140A	AN-4*	80A	10 Ft.
*The allocation to spares must be reduced and thus allow a feeder size reduction						
<u>PANEL DC - WING/ENGINE - BD (Sta 800)</u>						
L Wing (Tank 1)	5-BD L	1.0	1.6			
L Wing (Tank 2)	5-BD L	1.0	1.6			
C Wing Box	5-BD L	1.0	1.6			
R Wing (Tank 3)	5-BD L	1.0	1.6			
R Wing (Tank 4)	5-BD L	1.0	1.6			
Eng 1	1-BD (1) L	19	25			
Eng 2	3-BD	8	10			
"	4-BD	0.83	1.6			
"	1-BD (2) L	19	25			
Eng 3	1-BD (3) L	19	25			
Eng 4	3-BD	8	10			
"	4-BD	0.83	1.6			
"	1-BD (4) L	19	25			
Tail	3-BD	8	10			
"	4-BD	0.83	1.6			
Spares	5 SSPC	33.2	47.6			
Totals	20 Units	132.7A	190.4A	3-AN-4 (parallel) or 2-AN-3/0 (parallel)	240A 400A	35 Ft.
<u>RCCB DC - APU STARTING - BD (Sta 1400)</u>						
	9-BD M	190A	300A	2-AN 1/0* (parallel)	300A	90 Ft.

*Allowing 2.0 volts drop to starter

TABLE A
SSPC DISTRIBUTION ANALYSIS
AC SYSTEM

SSPC RATING:	<u>0.5A</u>	<u>1.6A</u>	<u>2.0A</u>	<u>3.0A</u>	<u>5.0A</u>	<u>7.5A</u>	<u>10.0A</u>	<u>15A</u>	<u>OTHER</u>
<u>GENERATOR BUS OR PANELBOARD</u>									
<u>1A</u>									
43 Active	5	14	-	3	1	9	3-1Ø	1-1Ø	1-20A-1Ø
21 Spare Spaces							3-3Ø	1-3Ø	1-20A-3Ø
64 Total									1-100A-3Ø
<u>2A</u>									
33 Active	3	8-1Ø	2	4	4	1-3Ø	3-1Ø	1-3Ø	1-100A-3Ø
15 Spare Spaces		2-3Ø					4-3Ø		
48 Total									
<u>3A</u>									
45 Active	3	10-1Ø	3	4	7	3-1Ø	5-1Ø	1-1Ø	1-100A-3Ø
15 Spare Spaces		2-3Ø				1-3Ø	4-3Ø	1-3Ø	
60 Total									
<u>4A</u>									
46 Active	3	15	1	3	1	8	3-1Ø	1	1-20A-1Ø
26 Spare Spaces							5-3Ø		1-20A-3Ø
72 Total									2-25A-3Ø
									1-25A-1Ø
									1-100A-3Ø
<u>AE</u>									
28 Active	11	2	7	3	1	1-3Ø	1-1Ø	1	
8 Spare Spaces							1-3Ø		
36 Total									
190 Active, Total (84 Spare Spaces)	25	49-1Ø 4-3Ø	13	17	14	20-1Ø 3-3Ø	15-1Ø 12-3Ø	4-1Ø 3-3Ø	11
Percent of Total Active SSPCs	13.2	27.9	6.8	8.9	7.4	12.1	14.2	3.7	5.8
Cumulative Percent of Total Active SSPCs	13.2	41.1	47.9	56.8	64.2	76.3	90.5	94.2	100.0

NOTE: All SSPCs are 1Ø unless noted otherwise.

TABLE B
SSPC DISTRIBUTION ANALYSIS
DC SYSTEM

SSPC RATING: GENERATOR BUS OR PANELBOARD	<u>0.5A</u>	<u>1.6A</u>	<u>2.0A</u>	<u>3.0A</u>	<u>5.0A</u>	<u>7.5A</u>	<u>10.0A</u>	<u>15A</u>	<u>OTHER</u>
<u>1D</u>									
46 Active	8	24	5	6	2	-	-	1	-
18 Spare Spaces									
64 Total									
<u>2D</u>									
39 Active	5	25	2	2	4	-	-	1	-
17 Spare Spaces									
56 Total									
<u>3D</u>									
47 Active	5	30	2	3	5	-	-	2	-
17 Spare Spaces									
64 Total									
<u>4D</u>									
43 Active	4	25	4	4	3	1	-	2	-
17 Spare Spaces									
60 Total									
<u>E</u>									
23 Active	-	9	4	1	4	2	2	-	1-20A
9 Spare Spaces									
32 Total									
<u>BB</u>									
41 Active	1	27	6	-	1	3	1	1	1-50A
19 Spare Spaces									
60 Total									
<u>BD</u>									
20 Active	-	8	-	-	-	-	3	2	1-20A
9 Spare Spaces									5-25A
29 Total									1-300A
259 Active, Total (106 Spare Spaces)	23	148	23	16	19	6	6	9	9
Percent of Total Active SSPCs	8.9	57.1	8.9	6.2	7.3	2.3	2.3	3.5	3.5
Cumulative Percent of Total Active SSPCs	8.9	66.0	74.9	81.1	88.4	90.7	93.0	96.5	100.0

APPENDIX B

ADVANCED SOLID STATE
POWER CONTROLLER DEVELOPMENT

PHASE I STUDY REPORT

20 FEBRUARY 1978

BY

D. E. LAUTNER
A. J. MAREK
J. R. PERKINS

FOR

TELEPHONICS CORPORATION

BY

VOUGHT CORPORATION
AN LTV COMPANY

TABLE OF CONTENTS

	<u>PAGE NO.</u>
1.0 INTRODUCTION.	274
2.0 SSPC INSTALLATION DESIGN CRITERIA	276
2.1 Electrical System Installation Requirements.	276
2.1.1 Load Management Center Considerations.	276
2.1.1.1 Cockpit Load Management Center	285
2.1.1.2 Left Avionics Bay Load Management Center	287
2.1.1.3 Right Avionics Bay Load Management Center.	288
2.1.1.4 Aft Section Load Management Center	288
2.1.1.5 Wing Station Load Management Centers	289
2.1.1.6 26 Volt AC Instrument Power Center	289
2.1.2 EMUX Hardware Installation	290
2.1.2.1 Multiplex Terminals.	291
2.1.2.2 EMUX Processors.	294
2.1.2.3 Maintenance Panel.	295
2.1.3 System Functional and Physical Configuration	295
2.2 Electrical System Load Complement.	295
2.2.1 SSPC Ratings	305
2.2.1.1 Current Capacity of Available Wire	317
2.2.1.2 Built-In-Test.	320
2.2.1.3 Multichannel vs Single Channel SSPC.	320
2.2.2 Load Starting Current Characteristics.	328
2.2.2.1 Lamps.	330
2.2.2.2 Motors	330
2.2.2.3 Transformers	331
3.0 SSPC CONFIGURATION TRADE AND ASSOCIATED COST IMPLICATIONS	333
3.1 SSPC/EMUX Interface.	333
3.1.1 Dedicated Wire Interface	334
3.1.2 Two Wire Multifunction Interface	337
3.1.3 Serial Data Channel Interface.	338
3.1.4 Multichannel SSPC Integrated Into EMUX Terminal.	340
3.2 SSPC Termination Technique	341
3.3 SSPC Installation Weight Factor.	352
3.4 SSPC Reliability/Maintainability Cost Impact	357
3.5 SSPC Configuration Trade Summary	357
4.0 SSPC SIGNAL INTERFACE CRITERIA.	359
4.1 Input-Output Signal Interface.	359
4.2 Normally Open/Normally Closed SSPC Option.	362
4.3 DC Power Output SSPC	365
4.4 SSPC Control Circuit Recommendations	366

TABLE OF CONTENTS
(Continued)

		<u>PAGE NO.</u>
5.0	POWER BUS ANALYSIS.	367
	5.1 Fault Current Calculation Method	367
	5.2 SSPC/Power Bus Interface Recommendations	375
6.0	SSPC SAFETY CONSIDERATIONS.	376
	6.1 SSPC Safety Design Implications.	376
	6.2 SSPC Leakage Current Recommendations	379
7.0	SSPC THERMAL CONSIDERATIONS	380
	7.1 Thermal Trip	381
8.0	SUMMARY	382
9.0	BIBLIOGRAPHY.	383

LIST OF FIGURES

	<u>PAGE NO.</u>
FIGURE 1 A-7 EMUX Inboard Profile	277
2 System Weight vs Distribution Center Quantities for Typical Attack Aircraft	282
3 Distribution Load Management Arrangement	284
4 Typical Load Management Center Design	286
5 EMUX Functional Schematic	296
6 Data Bus Installation	297
7 A-7 Load Distribution vs Required Power	299
8 Electronic LRU Load Distribution	300
9 Distribution of Loads With Inrush Currents	301
10 Weapon Load Distribution	302
11 Inductive Load Distribution	303
12 Weapon Station SSPC Sharing	304
13 115 VAC Load Distribution	306
14 28 VDC Load Distribution	307
15 26 VAC Load Distribution	308
16 115 VAC Electronic LRU Load Distribution	309
17 115 VAC Weapon Load Distribution	310
18 115 VAC Motor Load Distribution	311
19 115 VAC Lamp and Heater Load Distribution	312
20 28 VDC Electronic LRU Load Distribution	313
21 28 VDC Weapon Load Distribution	314
22 28 VDC Motor and Lamp Load Distribution	315
23 28 VDC Solenoid Device Load Distribution	316

LIST OF FIGURES
(Continued)

		<u>PAGE NO.</u>	
FIGURE	24	Normalized Harness Weight vs Number of SSPC Ratings	327
	25	Multi-Level Signal Interface	339
	26	Power Controller Configurations	344
	27	SSPC Weight vs LMC Controller Quantity	355
	28	Single Power Source for Power and Control	359
	29	Isolated SSPC Control Circuit	360
	30	Normally Closed Function Using Normally Open SSPC	362
	31	Typical Requirements for Normally Closed SSPC	363
	32	EMUX Power Down Capability Using Normally Closed SSPC	364
	33	AC SSPC Providing DC Output	365
	34	Fault Current Test Circuit	368
	35	Application of AC Fault Current Through a 35 Ampere Circuit Breaker	369
	36	Effects of 60 Hz Current on Average Adult Male	377
	37	Low Leakage DC SSPC	378
	38	Low Leakage AC SSPC	379

LIST OF TABLES

	<u>PAGE NO.</u>
TABLE 1 Current Capacities of Military Aircraft Wire	318
2 Current Capacities of Military Aircraft Wire Based on Voltage Drop and Temperature Limits	319
3 Steady State Current Rating as Function of Wire Gauge	321
4 Power Harness Hypothetical Weights	324
5 Normalized Harness Weight for SSPC Rating Mix	326
6 SSPC Current Ratings	329
7 Control Signal Interface Weight Comparisons	337
8 SSPC Termination Decision Matrix	345
9 SSPC Installation Weight Factors	354
10 Weight Estimates for SSPC Configurations	356
11 Wire Resistance	374
12 Circuit Breaker Maximum Voltage Drop	374

1.0 INTRODUCTION

This study was performed as a subcontract to the Advanced Solid State Power Controller Development program, AFAPL Contract F33615-77-C-2017. The work performed under this contract is in accordance with requirements of Telephonics Statement of Work 459A604. The purpose of this subcontract is to provide information about the use of Solid State Power Controllers (SSPCs) on aircraft which affect the SSPC design. The evolved data will be used by Telephonics Corporation to influence the design and development of SSPC devices, with the ultimate objective of making the SSPCs compatible with USAF requirements.

The program is divided into two phases. Phase I is directed to establishing data and requirements to support the design and development of the SSPC. Phase II will cover the testing and evaluation of the SSPC developed in Phase I.

This Phase I study report documents design and installation considerations and requirements of Solid State Power Controller (SSPC) devices as related to application on advanced military aircraft. The study encompasses a number of technical design and application factors of the SSPC which include:

- o SSPC Installation Design Criteria
- o Aircraft Power Bus Characteristics and Requirements
- o SSPC Safety Considerations
- o SSPC Input/Output Signal Interface Criteris
- o SSPC Thermal Considerations
- o SSPC Application Cost Factors

Each of these areas is discussed in the subsequent major paragraphs.

The Phase II final report will document the testing and evaluation of the SSPCs. The report will describe the test circuits, test procedure, test results, and conclusions and recommendations drawn from the test results.

2.0 SSPC INSTALLATION DESIGN CRITERIA

Discussed in this section are factors relating to the application and use of SSPC in typical fighter-attack aircraft.

Factors addressed include electrical system equipment (SSPC, EMUX hardware, loads and electrical cables and harnesses) installation requirements; SSPC load compatibility considerations which include load types, quantities and locations along with current starting requirements for typical loads; and a SSPC configuration trade.

2.1 Electrical System Installation Requirements

The EMUX equipment should be appropriately installed in the aircraft to provide maximum benefit to the aircraft electrical system. Equipment location is dictated by such system considerations as: proximity of SSPC's to loads served; length of power wire harnesses; and ease of maintenance access. Figure 1 depicts a representative installation for the A-7D. The loads served by the EMUX equipment are concentrated in the cockpit area and the avionic equipment bays. These normally congested areas must contain space provisions for the EMUX hardware and yet reasonable access for maintenance. To achieve this for the A-7D, some utilization equipment must be relocated to allow more optimum EMUX component location. It is noted that the optimum EMUX installation can best be attained in a new design as opposed to a retrofit type aircraft application. The installation of the EMUX equipment (retrofit type application) is discussed in detail in the following paragraphs.

2.1.1 Load Management Center (LMC) Considerations

Groups of Solid State Power Controllers (SSPC) are housed in metal enclosures and located in various aircraft areas. The enclosures provide protection to the SSPCs from mechanical, battle, and maintenance damage, while

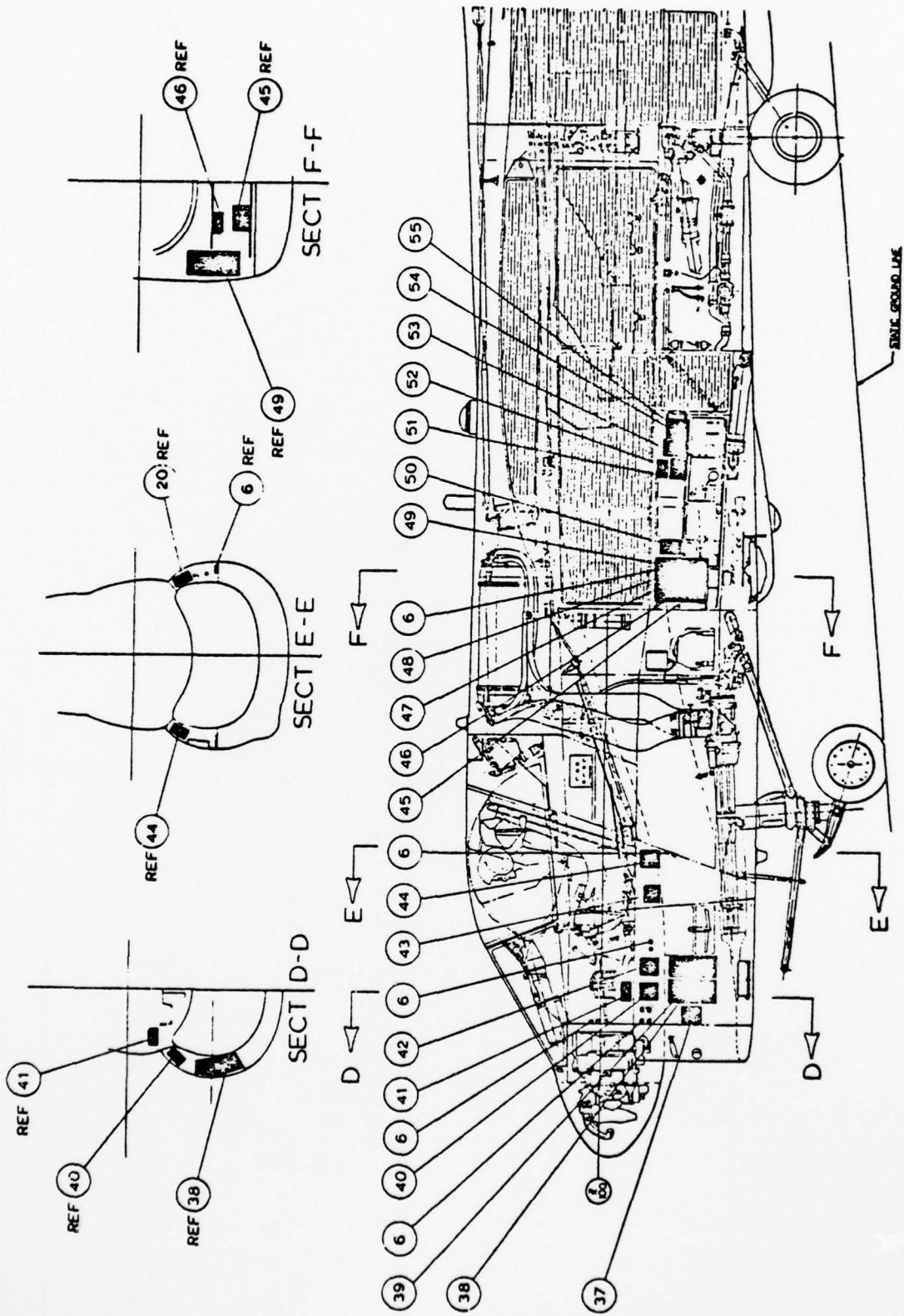

FIGURE 1a: A-7 EMUX INBOARD PROFILE

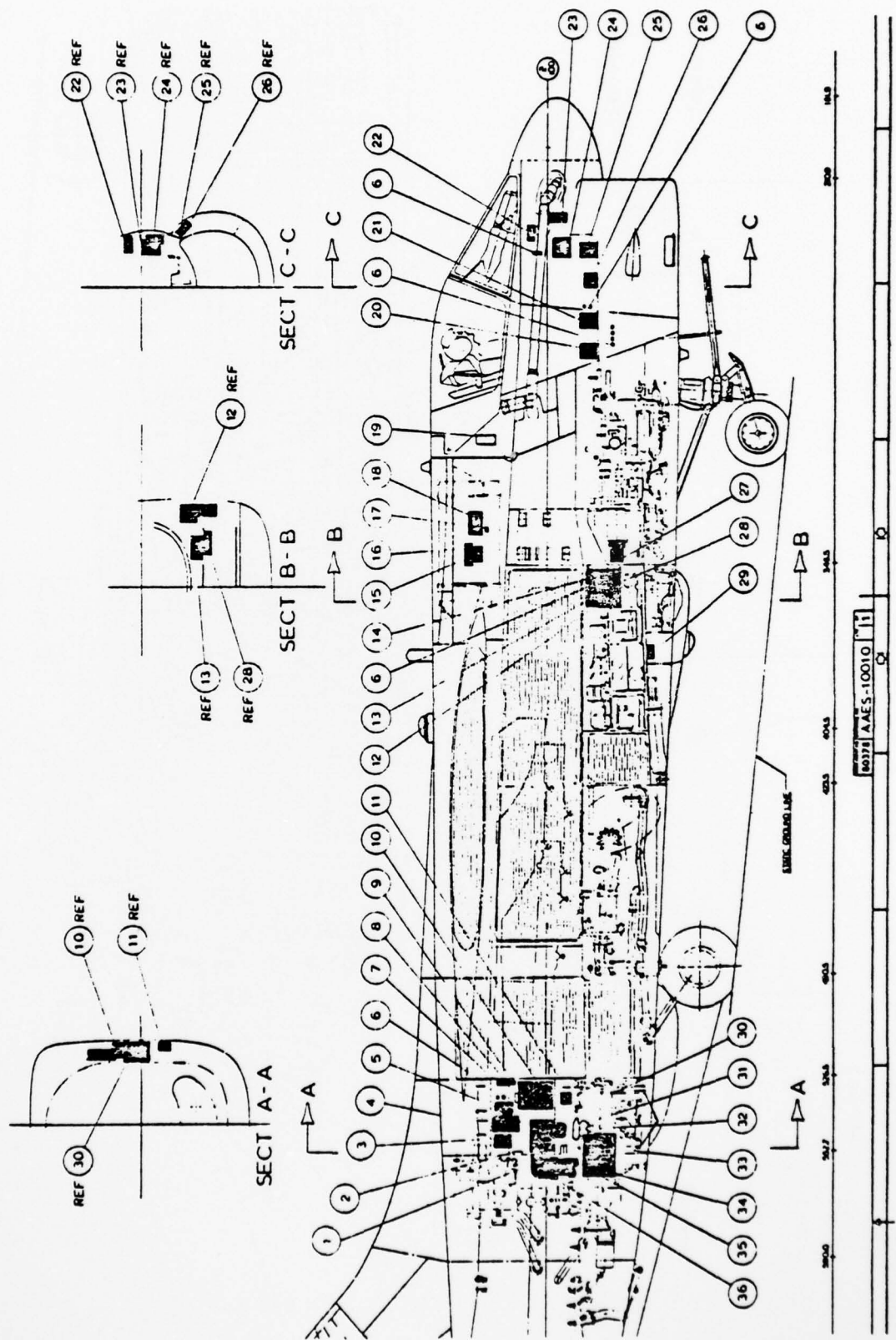

FIGURE 1b: A-7 EMUX INBOARD PROFILE

FIGURE 1
EMUX EQUIPMENT LOCATIONS

ITEM	ZONE	DESCRIPTION
1	E13.1	Current Sensor
2	E12.1	Controller, Main Bus
3	E12.1	EMUX Terminal 19
4	E12.1	Generator Control Unit, Main
5	E11.1	External Power Monitor
6	E11.1	Coupler, Data Line
7	E11.1	Bus Controller, External Power
8	E11.1	Fuse Panel, Main Generator
9	E10.1	Signal Conditioner Unit
10	E10.0	Load Mgmt. Center, Aft Section
11	E10.0	Receptacle, Ext Pwr
12	E10.1	Load Mgmt Center, R.H. Avionics Bay (Includes EMUX Terminals 17 & 18)
13	E 9.1	EMUX Processor, RH Avionics Bay
14	E 9.1	Relay Assy
15	E 8.1	Generator Control Unit, Emer
16	E 8.1	Fuse Panel, Emer Generator
17	E 8.1	Bus Controller, Emer
18	E 8.1	Power Conditioner Unit, Emer
19	E 7.1	Lighting Pwr Protective Unit
20	E 7.1	EMUX Terminal 7
21	E 6.1	EMUX Terminal 8
22	E 6.1	EMUX Terminal 2
23	C 5.1	Cockpit Interface Unit
24	C 5.1	26 VAC Instr Power Center
25	B 5.1	EMUX Terminal 3
26	B 5.1	Input/Output Card Assy
27	B 8.1	Generator, Emergency
28	B 8.1	Input/Output Card Assy
30	B11.1	Power Conditioner Unit, Main
31	B12.1	Heat Exchanger, Main Gen Gearbox
32	B12.1	Air Exhaust, PCU Cooling
33	B12.1	Generator, Main
34	B12.1	Air Intake, PCU Cooling
35	B13.1	Gearbox, Speed Increaser
36	B13.1	Fan PCU Cooling
37	C16.2	EMUX Terminal 9
38	D16.2	Load Mgmt Center, Cockpit ESS
39	E16.2	Load Mgmt Center, Cockpit Non-Ess
40	E15.2	EMUX Terminal 10
41	E15.2	EMUX Terminal 1
42	E14.2	EMUX Terminal 11
43	E14.2	Input/Output Card Assy.
44	E14.2	EMUX Terminal 5
45	E13.2	Weapon Station Switching Unit
46	E13.2	EMUX Terminal 15
47	E13.2	EMUX Terminal 13

FIGURE 1
EMUX EQUIPMENT LOCATIONS
(Continued)

ITEM	ZONE	DESCRIPTION
48	E13.2	EMUX Terminal 12
49	E12.2	Load Mgmt Center L.H. Avionics Bay (Includes EMUX Terminal 14)
50	E11.2	Card Assy
51	E11.2	EMUX Processor 1
52	E11.2	Weapon Type Data Unit
54	E10.2	EMUX Terminal 16
55	E10.2	Maintenance Panel (EMUX)
56	G18.2	Load Center, L.H. Wing
57	G18.2	Load Center, R.H. Wing
58	F18.2	EMUX Terminal 20
59	E18.2	EMUX Terminal 23
60	G17.2	Terminal Strip
61	G17.2	Card Assy, Signal Conditioner
62	E 9.2	Starter Battery, (Relocated)

AD-A063 405

TELEPHONICS CORP HUNTINGTON N Y
ADVANCED SOLID STATE POWER CONTROLLER DEVELOPMENT. PHASE I. STU--ETC(U)
SEP 78 R J EDWARDS

F/G 10/2

F33615-77-C-2017

NL

UNCLASSIFIED

AFAPL-TR-78-55

4 OF 5

AD A063405

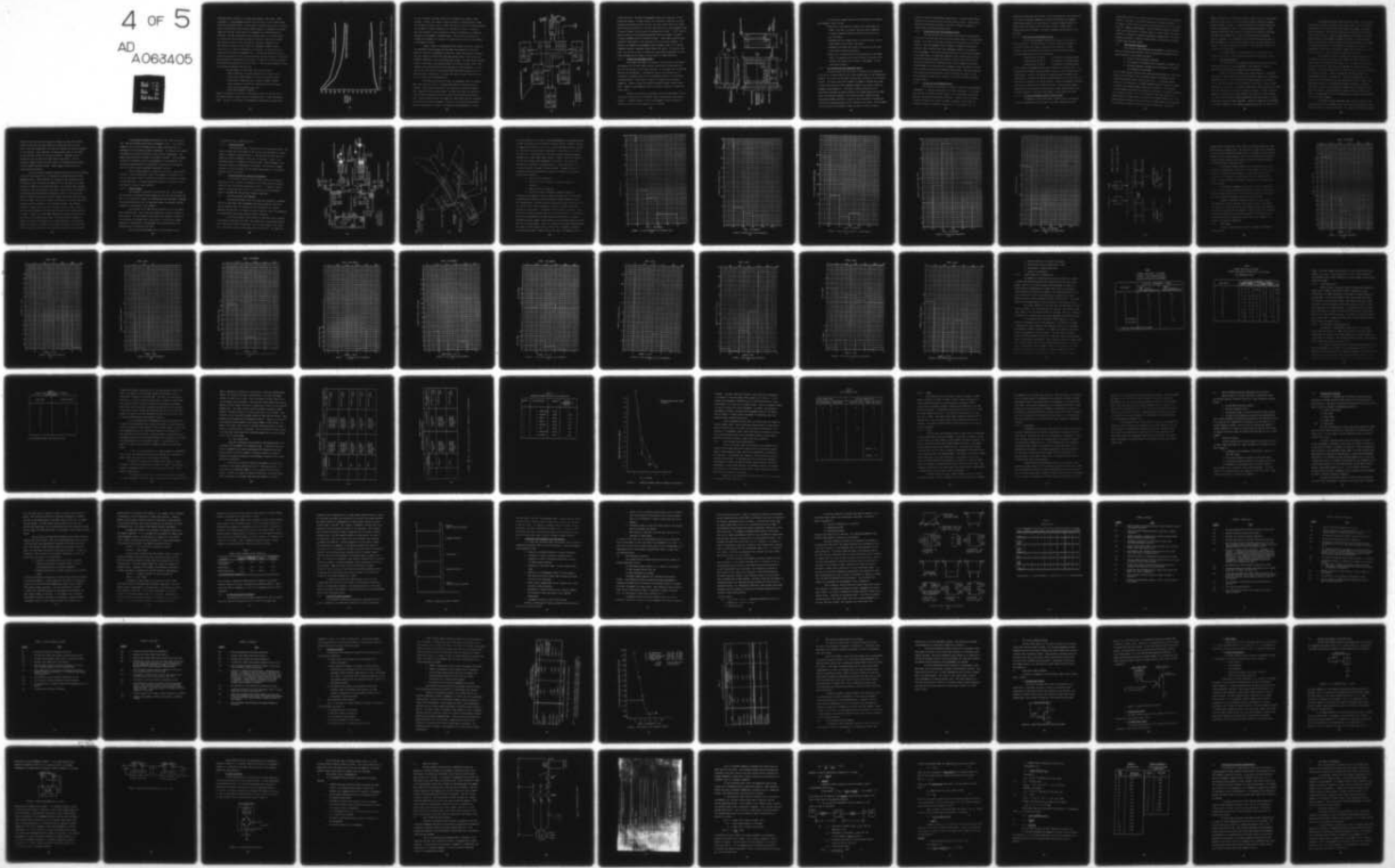

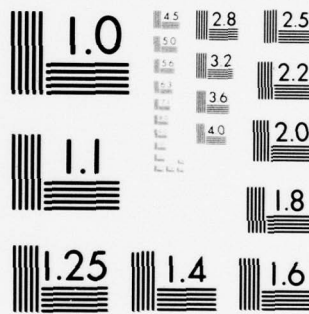

MICROCOPY RESOLUTION TEST CHART
NATIONAL BUREAU OF STANDARDS-1963-A

affording similar protection to the main and emergency power buses. These enclosures or "Load Management Centers" form the nuclei of the aircraft power distribution subsystem (PDS). Since the LMC is the PDS nucleus, one of the first steps in advanced aircraft electrical system design is to determine the optimum number and location of LMCs required to implement all aircraft electrical functions. Two basic approaches for LMC location exist: (1) one LMC located in the aircraft load centroid servicing all electrical loads; vs (2) several LMCs located in areas of high load density. The major advantage of the centralized LMC concept is that a power bus management (feeders, feeder protectors, etc.) system is essentially not required. The buses within the centralized LMC provide bus management (i.e., switching between power sources) and the fault protection built into the generator provides protection of the power feeders between the generators and the buses. In addition, the point of generator system voltage regulation is at the LMC bus. This location minimizes voltage drop between the generator and each load.

The advantages of a distributed LMC concept include:

- o Lower vulnerability to combat damage since no single location exists where combat damage could destroy all aircraft power.
- o Maintenance is simplified due to smaller packages of SSPCs.
- o Heat dissipated by the SSPCs is distributed about the aircraft rather than concentrated in one area.
- o Total system weight is reduced.

Figure 2 illustrates the variation in PDS weight for an A-7 type aircraft as the number of LMCs is varied from one (centralized LMC) to seven (Distributed LMCs). As shown in the figure, bus management system weight (includes SSPCs

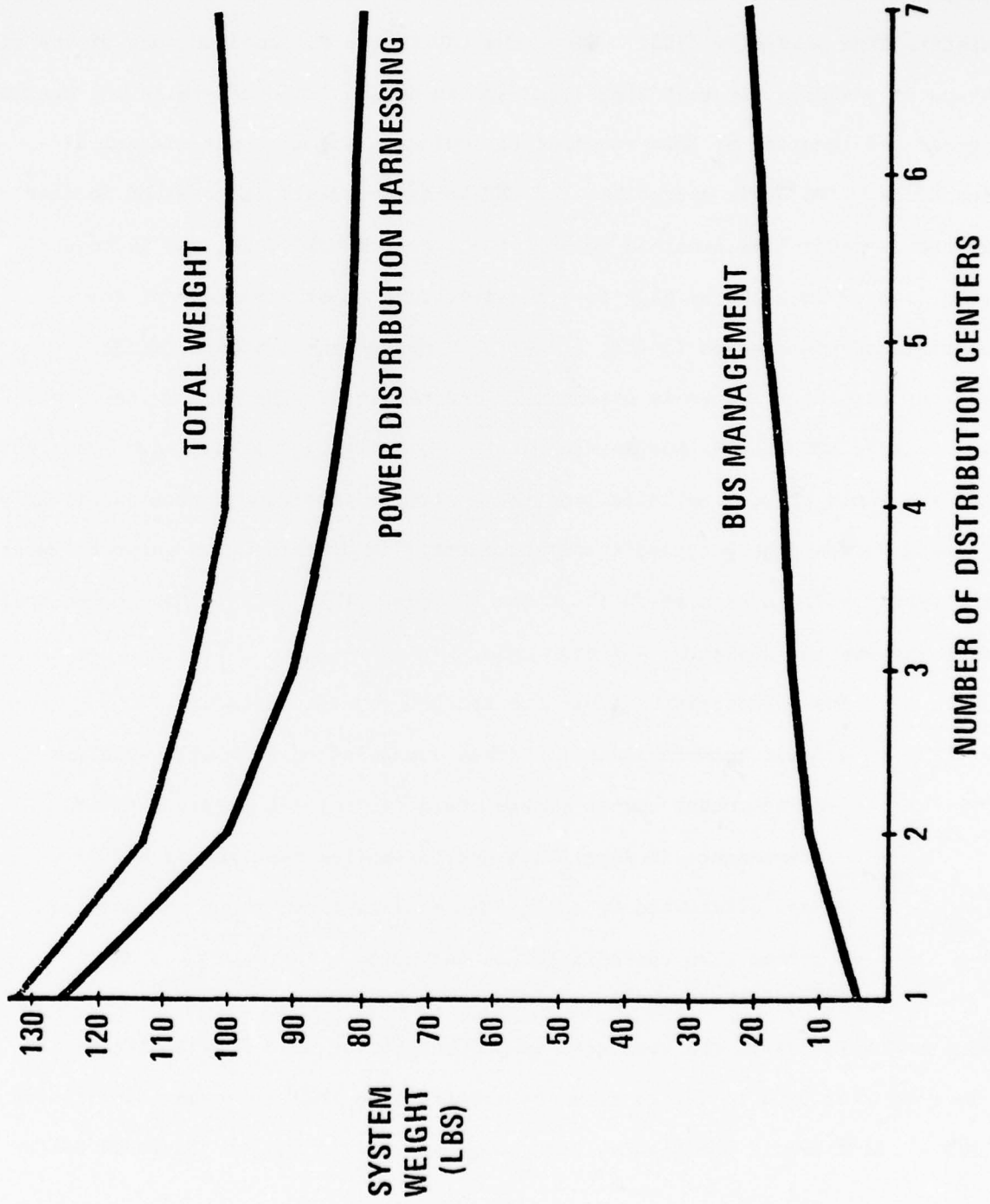

FIGURE 2: SYSTEM WEIGHT VS DISTRIBUTION CENTER QUANTITIES FOR TYPICAL ATTACK AIRCRAFT

as well as feeders and feeder protectors) increases as the number of LMCs increase. However, the weight of power distribution wiring decreases as LMCs are divided and located closer to loads. The result is that total weight decreases as the number of centers increase (up to six LMCs for the A-7). Above six LMCs, the decrease in power distribution wiring is insufficient to offset the increase in bus management hardware weight. For an A-7 size aircraft, the optimum LMC arrangement as a function of weight dictates use of six distributed load management centers.

Figure 3 depicts a representative LMC concept for the A-7 along with the approximate feeder lengths and the steady state essential (E) and non-essential (NE) power requirements for each LMC. These load centers are located near the cockpit, in the left and right hand avionics bays, in the aft section equipment compartment, and in each wing pylon station. The LMC hardware consists of power controllers, a bus isolation relay, bus isolation diodes, feeder input terminal strips and mounting structure required for these components. The two avionics bay load centers, left hand and right hand side, contain one and two EMUX terminals, respectively. The wing load centers in pylon stations #2 and #7 also contain one EMUX terminal each.

The construction details of each load management center are similar. They would typically be built of formed sheet metal and extrusions riveted together to form support structure for the controllers, multiplex terminal, other components and associated wiring. The power controllers are mounted on .125 inch thick aluminum plates which serve as both mounting plate and heat sink. Self-locking blind nuts are swaged into these plates and the controllers are secured with screws and washers. The use of this controller installation technique minimizes the hardware to be handled during maintenance or circuit

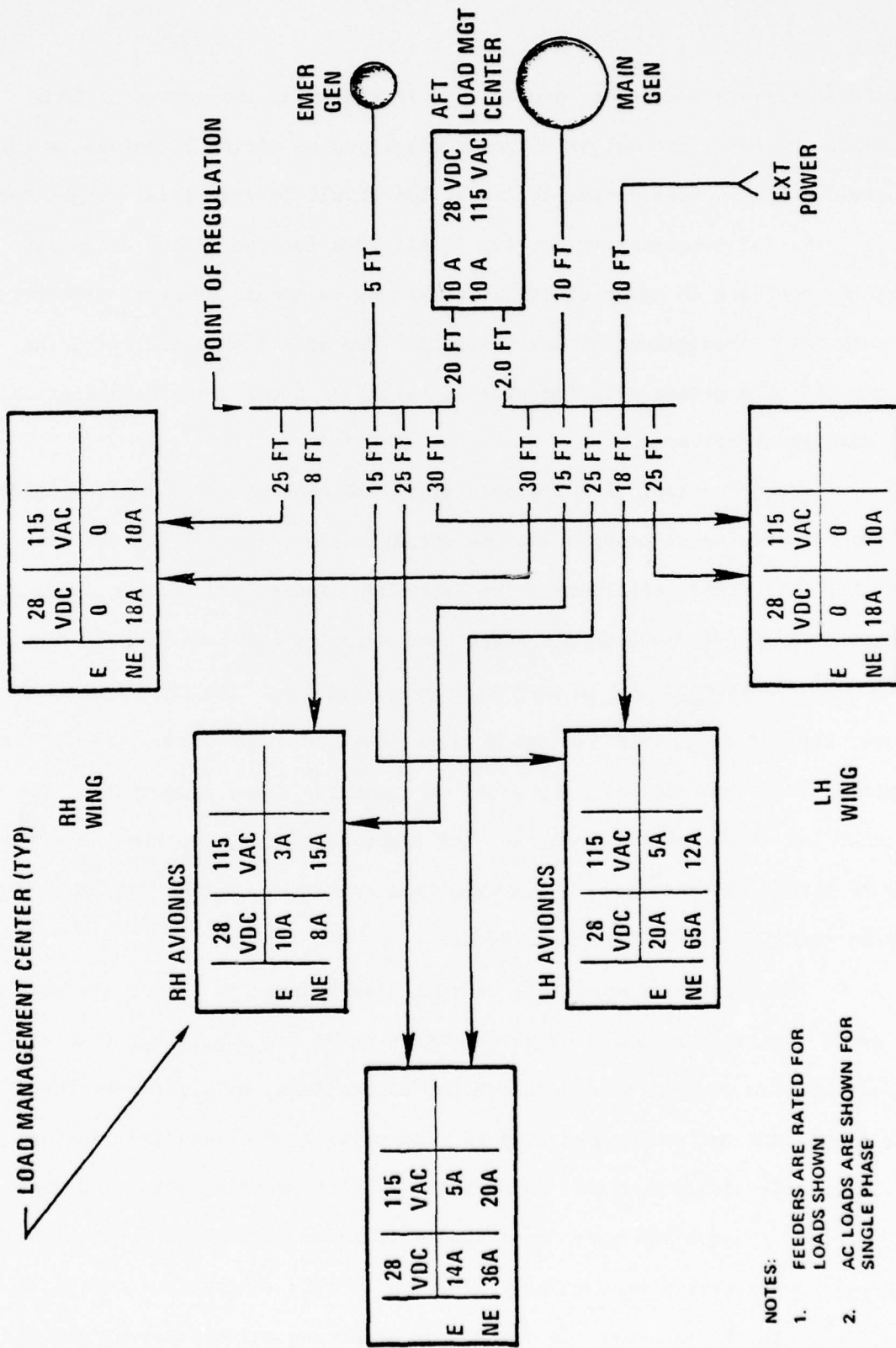

FIGURE 3: DISTRIBUTION LOAD MANAGEMENT ARRANGEMENT

change operations. The wing load management centers are exceptions to this installation method. In these centers, the controllers, terminals, and other components are mounted directly to one of the pylon access panels with screws, washers and self-locking nuts. The left hand avionics bay load management center is shown in Figure 4 and is typical of fuselage load centers. In this center it should be noted that two mounting plates/heat sinks are hinged to the main structural assembly and one is rigidly attached. These hinged mounting plates provide for easy access to all controllers in the load center assembly. In addition, the complete load management center assembly hinges out to provide convenient access to components mounted behind the center. To swing the load center out, two (2) to four (4) quarter turn type captive fasteners can be unlocked allowing the load center to rotate about its hinge centerline.

2.1.1.1 Cockpit Load Management Center

The cockpit load center is located on the left side of the aircraft approximately two (2) feet behind the duct lip and five (5) feet above the deck with the aircraft in the static position. It is divided into two sections, essential and nonessential. The essential section has provisions for 79 controllers (including spares) and the nonessential section, 51 controllers (including spares). Each section is made up of hinged controller panel assemblies. Access to these load centers is gained through a single access panel. Removal of approximately twenty (20) screws is required to remove the access panel.

Based on the vibration, acceleration and shock requirements for the controllers as specified by MIL-P-81653, special mounting provisions are not required. A thermal analysis for the load management center installation showed that special thermal protection is not required.

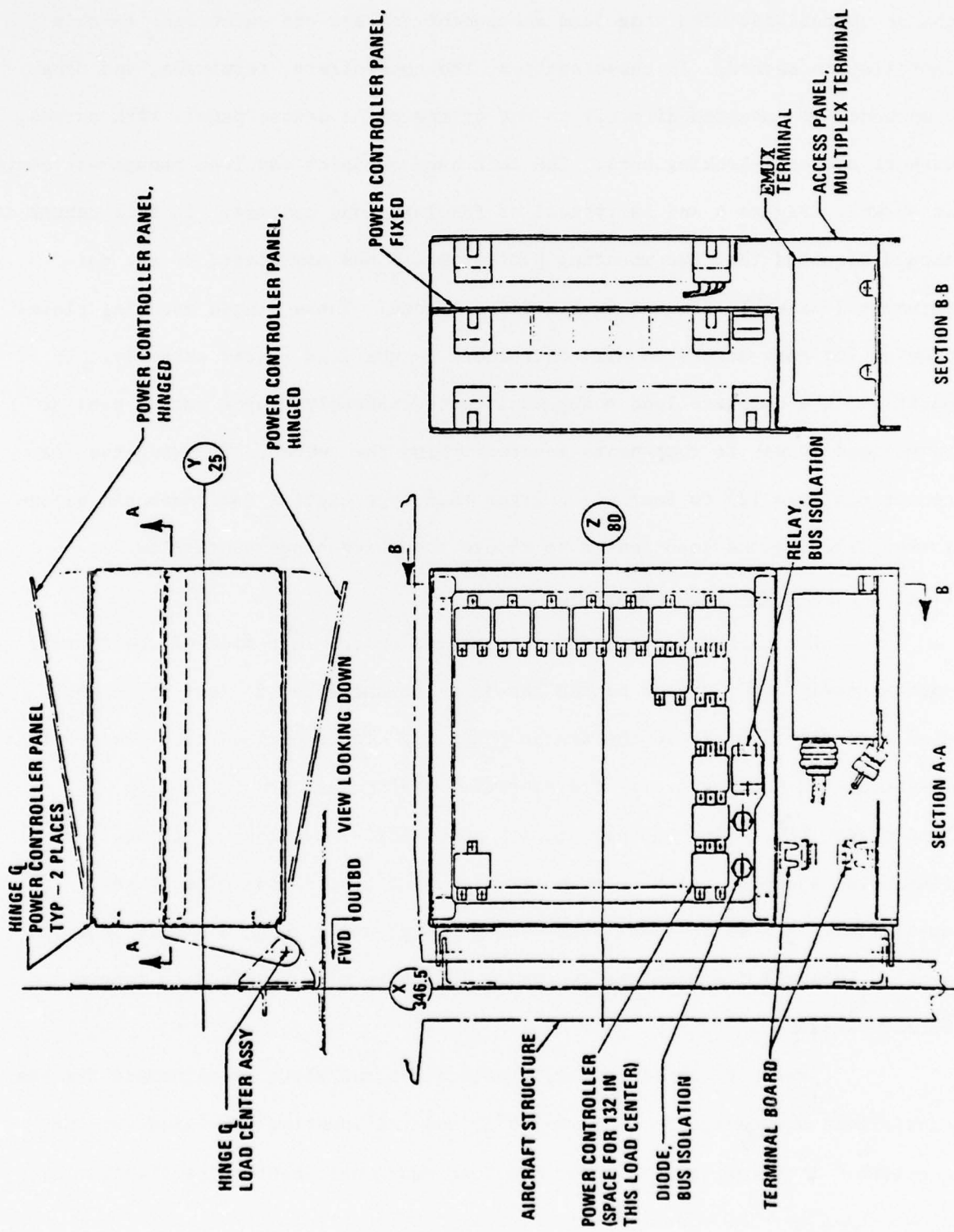

FIGURE 4: TYPICAL LOAD MANAGEMENT CENTER DESIGN

A-7D structural changes required for installation of the cockpit load management center include:

- o Reduction of cross-sectional height of two sheet metal duct frames in the area of the power controller panel assemblies to provide clearance between the skin and the air duct for the load center.
- o Redesign three duct frames locally to provide support for the hinged panels of the cockpit load center.
- o Redesign the aircraft skin locally to provide the load center access panel and back-up structure.
- o Design two (2) intercostals to provide support for the hinged panels to strengthen the air duct and skin in the area of the reworked duct frames and to provide an edge member for the access panel opening.

2.1.1.2 Left Avionics Bay Load Management Center

The left avionics bay load center is located at the forward end of the bay in the space used for the circuit breaker panel in the conventional aircraft. It is five (5) feet above the deck with the aircraft in the static position. The entire load center assembly is hinged to provide easy access to power controllers and other components mounted in the center as well as equipment located behind it. The center contains provisions for 132 controllers (including 34 spares) mounted on two hinged panels and one fixed panel, one multiplex terminal, a bus isolation relay, diodes and other associated equipment and wiring. Access to this load center is through the existing quick opening avionics bay door hinged at the bottom. The environment in the avionics bay is adequate to meet the needs of the load center

without any special environmental considerations. Structural modifications required for the installation of this load center are minor. These involve adding new hinge support brackets to the X346.5 bulkhead, trimming the avionics shelf and adding new panel stops.

2.1.1.3 Right Avionics Bay Load Management Center

The right avionics bay load center is located at the forward end of the bay in the space used for the circuit breaker panel in the conventional design. It is five (5) feet above the deck with the aircraft in the static position. The load management center assembly is hinged to provide easy access to power controllers and other components mounted in the center as well as equipment. The center contains provisions for 48 controllers mounted on two fixed panels, two multiplex terminals, a bus isolation relay, diodes and other associated equipment and wiring. Access to this load center is through the existing quick opening avionics bay door hinged at the bottom. The environment in the avionics bay is adequate to meet the needs of the load center without any special environmental considerations. Structural modification required for the installation of this load center are minor. These involve adding new hinge support brackets to the X346.5 bulkhead and adding new panel stops.

2.1.1.4 Aft Section Load Management Center

The aft section load center is located in the aft section equipment compartment. It contains provisions for 28 power controllers. It is hinged from the X526.5 bulkhead to provide access to the controllers and the main generator fuse panel located behind the center. Access to this load center is gained through the aft section equipment compartment access panel (an enlarged A-7D battery compartment access panel). The center is five (5)

feet above the deck with the aircraft in the static position. The construction of aft section equipment compartment provides the necessary environmental conditioning required by the load center. Structural changes required to install this load center into the aircraft are minor. These involve adding hinge support brackets to the X526.5 bulkhead and panel stops to the new floor.

2.1.1.5 Wing Station Load Management Centers

The wing load management centers are located in the pylons at each wing station. They are located in the space previously occupied by the hoist provisions (no longer required on the conventional or EMUX airplane). The load centers in the pylons at each wing station contain the following provisions for power controllers:

- o Wing stations #1 and #8 18 controllers (including spares)
- o Wing stations #2 and #7 12 controllers (including spares)
- o Wing stations #3 and #6 14 controllers (including spares)

Each of these load management centers has a feeder input terminal strip. All controllers and terminal strips are mounted directly to their respective pylon access panels. Access to the centers is gained through the opposite pylon access panel. All pylon load centers are approximately six (6) feet above the deck with the aircraft in the static position. Special environmental considerations are not required for the wing load centers. The structural changes required for the installation of these centers involve adding mounting holes and back-up angles to the pylon access panels. These changes are minor.

2.1.1.6 26 Volts AC Instrument Power (Cockpit) Center

In addition to the six main LMCs, a special LMC for controlling 26 volt ac instrument power is located in the right rudder pedal access

approximately seven (7) feet above the deck with the aircraft in the static position. This power center has provisions for 18 power controllers. It is hinged to allow access to the power controllers as well as to the rudder pedals for rigging and maintenance. Access is gained through the existing rudder pedal access panel. The power center is located inside the cockpit, therefore, it requires no special environmental considerations. Only minor changes are required to install the power center, these being the addition of hinge angles and panel stops.

2.1.2 EMUX Hardware Installation

The location of EMUX terminals was determined by distribution of loads and of input signal sources. The two central data processors can be located anywhere in the aircraft as long as:

- a) Access to the data buses is available
- b) The processor is compatible with the ambient environment, and
- c) Sufficient separation between the two processors is achieved for vulnerability enhancement.

The only EMUX terminal location factor affecting system weight and reliability results from the length of wire harnessing between the terminal and the interfacing hardware (SSPCs, signal sources, etc.). To minimize harness length for input functions to the EMUX terminal requires locating the terminal to minimize the average distance from source to terminal. The constraint on this minimization results from physical restrictions of locating the terminal at the desired location. Due to this constraint, the input channels to an EMUX terminal will almost never be located at the desired minimal point. The minimalization constraints are not as severe for EMUX terminal output channels. Most EMUX output channels interface with power controllers. Since these

SSPCs are installed in a protective enclosure, their location is concentrated into several small areas. This concentration permits reducing the harness between terminal and SSPC to a length constrained only by space availability at the load management centers. To afford comparable protection to EMUX terminals controlling power flow as is provided to the source of that power, the EMUX output terminals will ideally be enclosed within the same LMC protective housing. This packaging concept was established as the goal for EMUX implementation of the A-7D and was achieved for all LMCs except in the cockpit. The EMUX terminals were, however, located immediately adjacent to the LMC at the cockpit LMC.

The paragraphs which follow discuss the physical location and installation details for EMUX terminals, processors, and maintenance panel.

2.1.2.1 Multiplex Terminals

The installation of the multiplex terminals in the aircraft has not required any special cooling requirements. Some terminals do require isolation mounts because of vibration and shock environment.

Three (3) multiplex terminals are located adjacent to the cockpit load center. These terminals are isolation mounted to make their installation compatible with the vibration and shock environment imposed by the M61 gun. Six (6) data line couplers are also installed in this area. Access to these components is through two (2) screwed-on access panels approximately five (5) feet above the deck with the aircraft in the static position. Aircraft structural changes for installation of these components are similar to those described for the cockpit load center requiring additional sheet metal parts to provide mounting structures for these components. Three duct frames are also modified to provide clearance for the terminals between the duct and the aircraft skin.

One terminal serves the loads in the left console. It is located just outside the cockpit, adjacent to the console area. Two (2) data line couplers and the left hand console input/output card assembly are located near this terminal. They are six(6) feet above the deck with the aircraft in the static position. Access to these components is through a new access panel secured with approximately sixteen (16) screws. Structural changes made to the aircraft for this installation involve reworking two duct frames to add mounting brackets for the terminal, I/O assembly and couplers. An edge member is added and the skin panel, longeron and bulkheads in the area are also modified to make provisions for the new access panel.

Three terminals, two for the right hand console loads and one for instrument board loads, are located just outside the cockpit adjacent to the RH console and instrument board areas. Six (6) data line couplers and the right hand console input/output card assembly are located near these terminals, and are approximately six (6) feet above the deck with the aircraft in the static position. Access is through two new panels secured with approximately sixteen (16) screws each. Structural changes made to the aircraft for this installation involve reworking six (6) duct frames to add mounting provisions for the terminals and signal conditioner. Mounting provisions are added to the windshield bulkhead and lower longeron for the data line couplers. New edge members are added around the forward access panel. The edge members of the aft compartment are changed to add provisions for the new panel fasteners.

Two terminals serving instrument board loads are located in the cockpit forward of the instrument board, one on the left hand side and one on the right hand side, near the outer skin. The right hand terminal is directly

forward of the slant panel and access is through the rudder pedal access. To make room for the left hand terminal, the radar desiccator unit was moved to the radar compartment. Two data line couplers are installed adjacent to each terminal. These components are approximately eight (8) feet above the deck with the aircraft in the static position. Component access is through the left and right hand rudder pedal access panels. The only structural changes required are those needed to provide mounting provisions for each terminal and data coupler. These changes are minor and no new access panels are required.

Five (5) multiplex terminals serving avionics bay loads are installed in the left hand avionics bay. One terminal is installed inside the load management center. Three terminals are installed in the forward end of the bay inboard of the load center and between the floor and shelf in the space reserved for LORAN on the conventional design. One of these three terminals is mounted on the bottom surface of the shelf. The other two are installed on new mounting structure between the shelf and the floor. The PC card rack assembly (assembly contains output cards, signal conditioning cards and relay cards) and eight (8) data line couplers are installed in the space used by the existing relay rack assembly on the conventional design. The remaining terminal is located at the aft end of the shelf on the top side. Four (4) data couplers are mounted at the aft end of the bay for the terminal and the processor. Access to all these EMUX components is through the avionics bay door which is quick opening and hinged. The avionics bay environment is adequate to meet the requirements of all these components. The structural changes are confined to changing the mounting hole patterns in the floor and shelf and adding a simple sheet metal structure between the floor and shelf.

Two multiplex terminals are installed in the right hand avionics bay. They are installed inside the load management center. One multiplex terminal, two (2) data line couplers and a signal conditioner unit are installed in the aft section equipment compartment. The terminal and couplers are mounted on the inboard web near the aft end of the compartment. The signal conditioner unit is mounted on the X526.5 bulkhead. The environment of this bay is adequate to meet the requirements of the components. The structural change required for installation of these units is included as part of the new aft section equipment compartment build-up.

One multiplex terminal is installed in the pylon at wing stations #2 and #7. Also an input/output circuit card assembly is installed at all six (6) wing station pylons. No special environmental protection is required by these components. Two formed sheet metal brackets are required for the installation of each of these components.

2.1.2.2 EMUX Processors

One processor is installed in each avionics bay. The processor in the left bay is supported from the engine air duct near the aft end of the bay. Two (2) data line couplers are installed near this processor. Mounting structures consisting of four (4) sheet metal angles and several clips are provided for installation of the processor.

The processor in the right bay is installed on top of the shelf near the forward end. Two (2) data line couplers are installed adjacent to the processor. The right hand bay input/output card assembly is mounted to the bottom side of the shelf near the processor. The structural changes required for installation of this equipment involve adding inserts and mounting holes to the avionics bay shelf.

The avionics bay environments meet all requirements for the

installation of the two EMUX processors.

2.1.2.3 Maintenance Panel

The maintenance panel is located in the left hand avionics bay. The panel is hinged from the bulkhead at the aft end of the bay (X404.5) to provide access to equipment installed behind it. The tape collector and tape cartridge are directly accessible on the front of the panel. Access to the maintenance panel is through the avionics bay door. The environment of the avionics bay meets the requirements of the panel. The structural changes required to install the panel involve adding hinge brackets to the bulkhead and panel stops to the shelf.

2.1.3 System Functional and Physical Configuration

The functional schematic shown in Figure 5 depicts the general functional as well as physical configuration of an EMUX controlled aircraft electrical power distribution subsystem for the A-7. In addition, Figure 6 presents a prospective view of the A-7 to illustrate a three dimensional layout of the EMUX data bus and major hardware components.

2.2 Electrical System Load Complement

The electrical loads of the A-7 aircraft were analyzed to determine the mix of load types, power requirements and power categories. While the load mix analysis gives an indication of load distribution in a typical fighter-attack aircraft, the results can also be used as a basis for determining the optimum solid state power controller (SSPC) rating mix.

In the load discussion which follows, an electrical load is defined as any device connected to each SSPC. This means that if a given LRU requires 3Ø ac power plus dc power for operation, that LRU would equate to four loads (i.e., one load for each ac power phase and one load for dc). The reason for

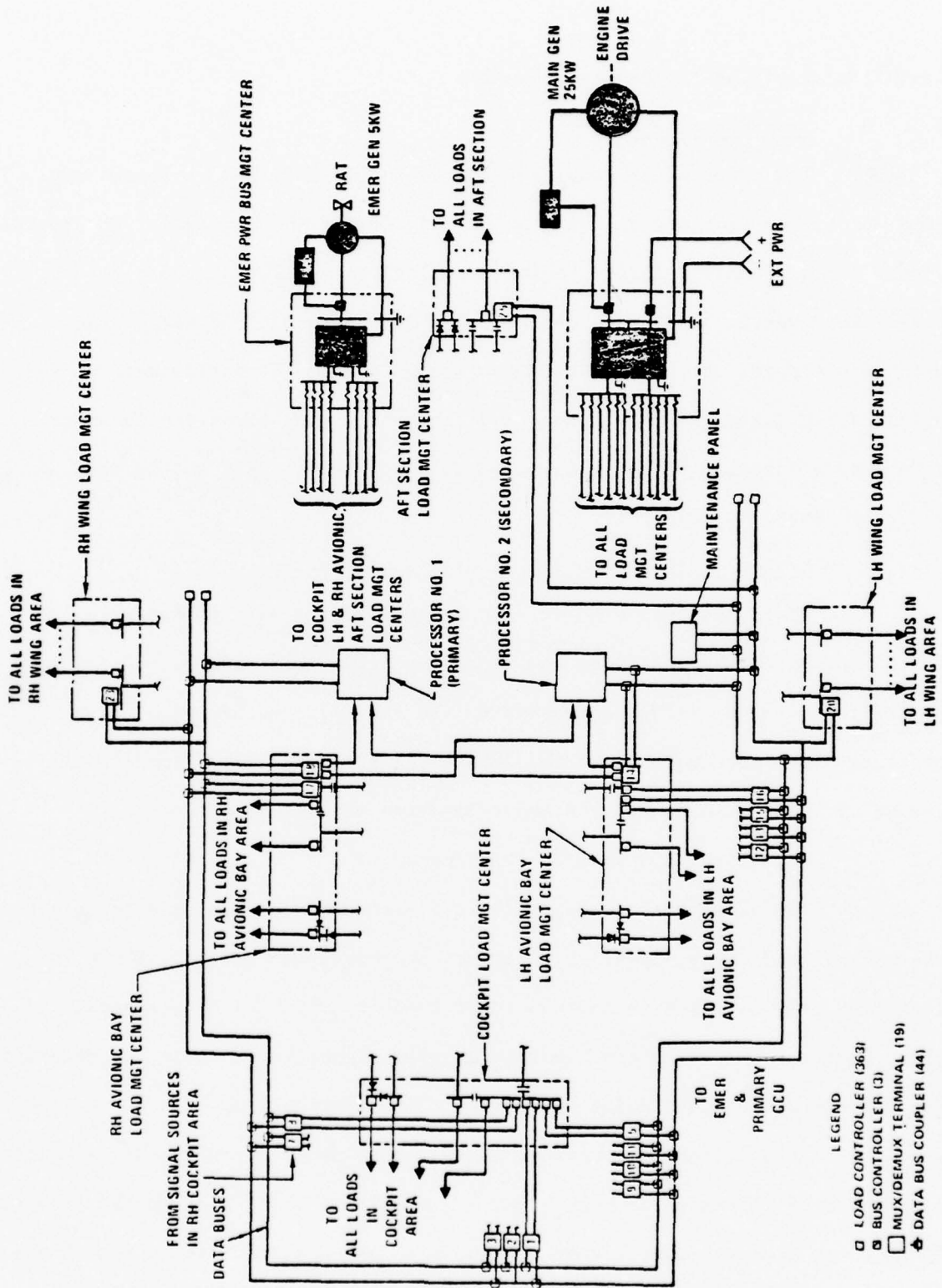

FIGURE 5: EMUX FUNCTIONAL SCHEMATIC

NOTE

- 1. ALL UNITS NOT CALLED OUT ARE MULTIPLEX TERMINALS
- 2. PRIMARY DATA BUS
- - - - - SECONDARY DATA BUS

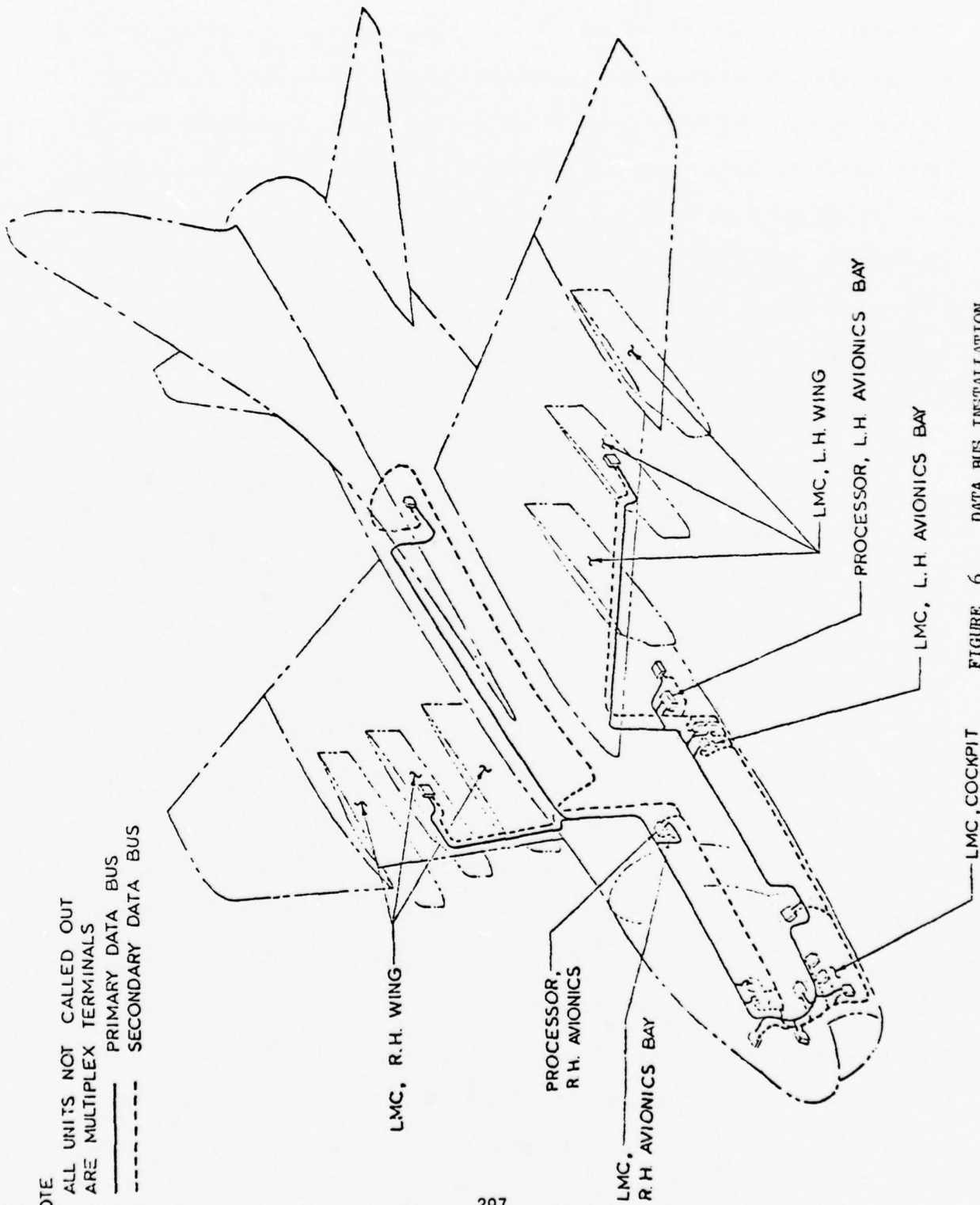

FIGURE 6 DATA BUS INSTALLATION

this load definition is to yield a load mix meaningful to the number and type of power switching functions required to operate the LRU. Figures 7 through 11 summarize the quantity of loads (i.e., power switching functions) required as a function of delivered power (independent of power type, i.e., 28 VDC, 115 VAC, etc.). The figures are in bar chart formats illustrating general distribution of loads versus power required. Figure 7 depicts the distribution for all aircraft loads independent of load type. This total load distribution illustrates the expected spread of loads versus power, (i.e., as power increases, the number of loads decrease). Figures 8 through 11 illustrate the load distribution as a function of power for the following various load categories:

- a) Electronic LRUs (Figure 8).
- b) Loads with in rush current, e.g., motors, lamps, etc.
(Figure 9).
- c) Weapons (stores) (Figure 10).
- d) Loads with turn-off transients (inductive) (Figure 11).

The weapon load category is used as a general grouping due to the projected implementation technique for operating weapons on EMUX equipped aircraft. This implementation technique involves establishing a power controller set at each weapon (store) station sufficient to handle all weapon combinations expected for that station. To minimize the SSPC count at any station, each SSPC will be used for multiple functions. The SSPC function for a particular store will be determined by the EMUX processor software and by a weapon dedicated electrical adapter cable between the store station electrical interface and the carried weapon. Figure 12 illustrates this SSPC sharing function. As a result of SSPC sharing, the total SSPC count is reduced in exchange for requiring each SSPC to power various load types. For example, for one

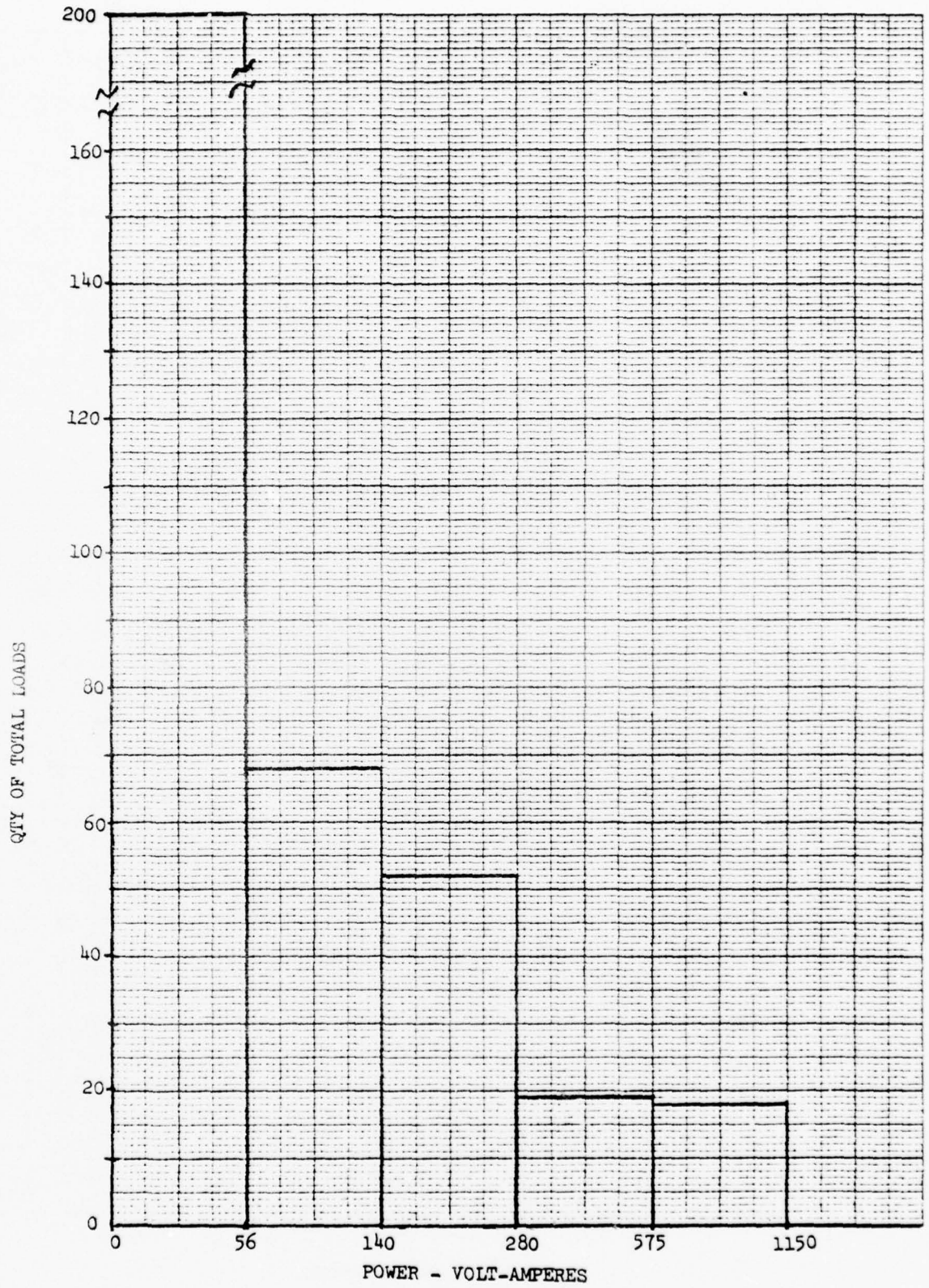

FIGURE 7 A-7 LOAD DISTRIBUTION VS REQUIRED POWER
299

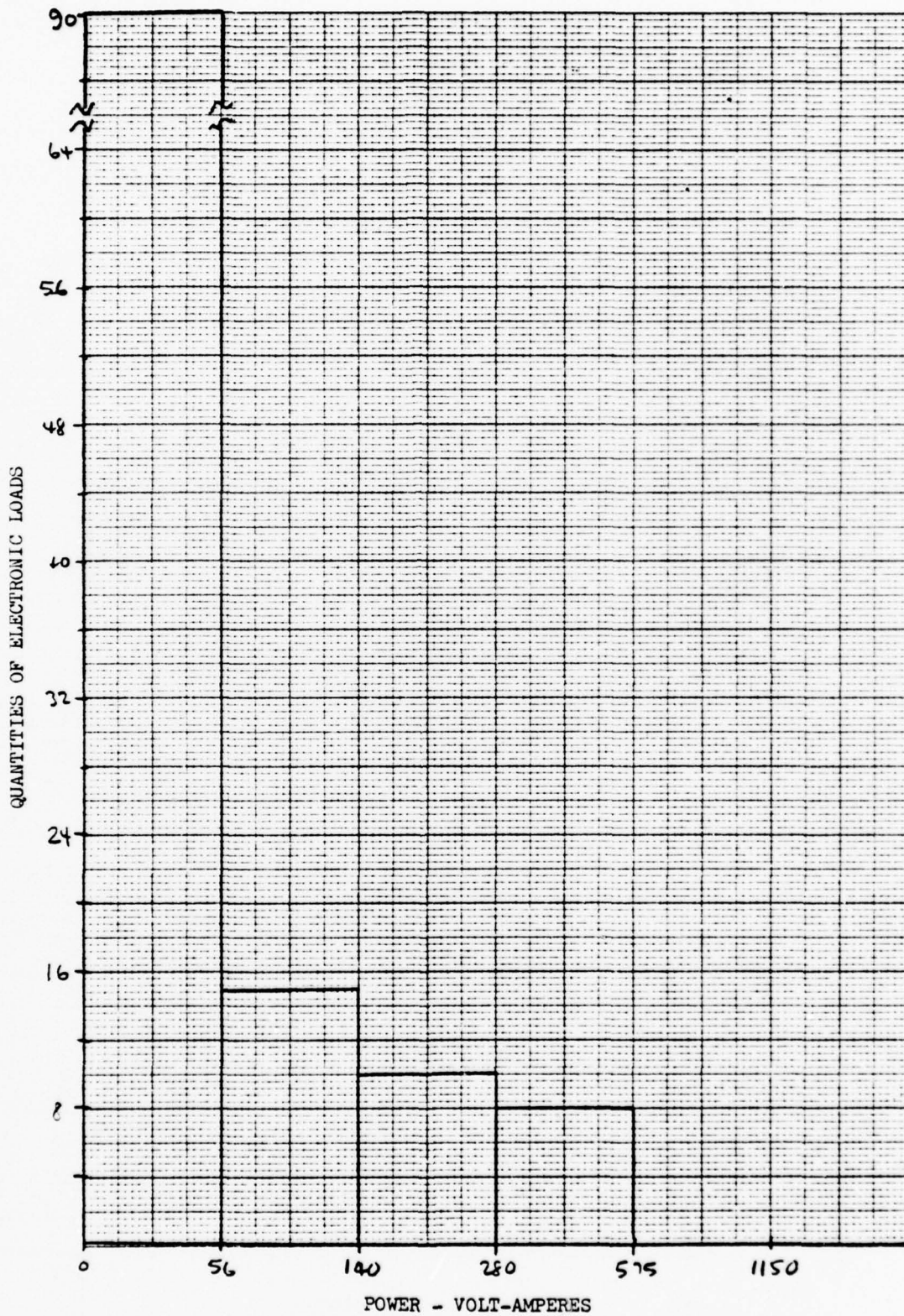

FIGURE 8 ELECTRONIC LRU LOAD DISTRIBUTION

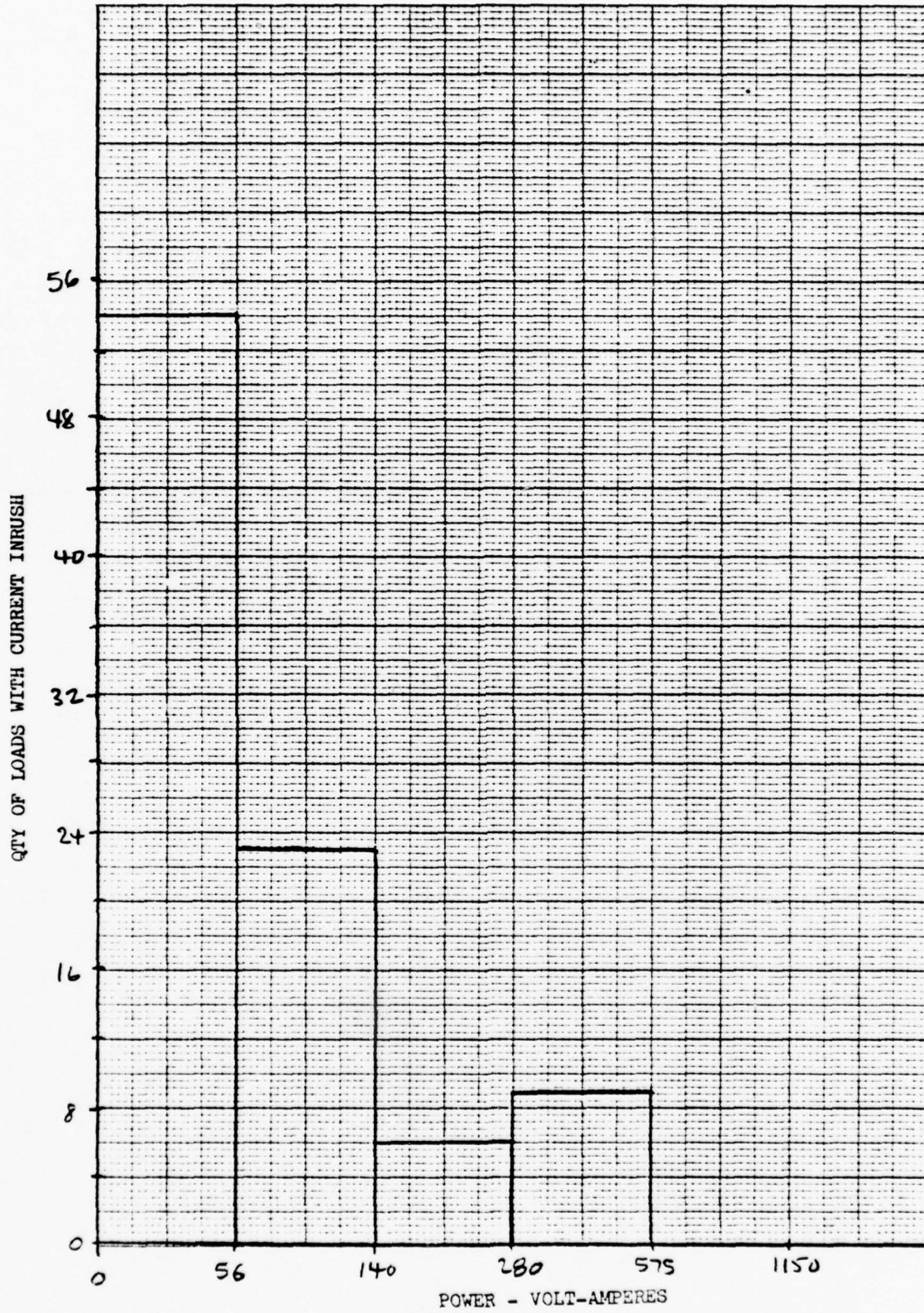

FIGURE 9 DISTRIBUTION OF LOADS WITH INRUSH CURRENTS
301

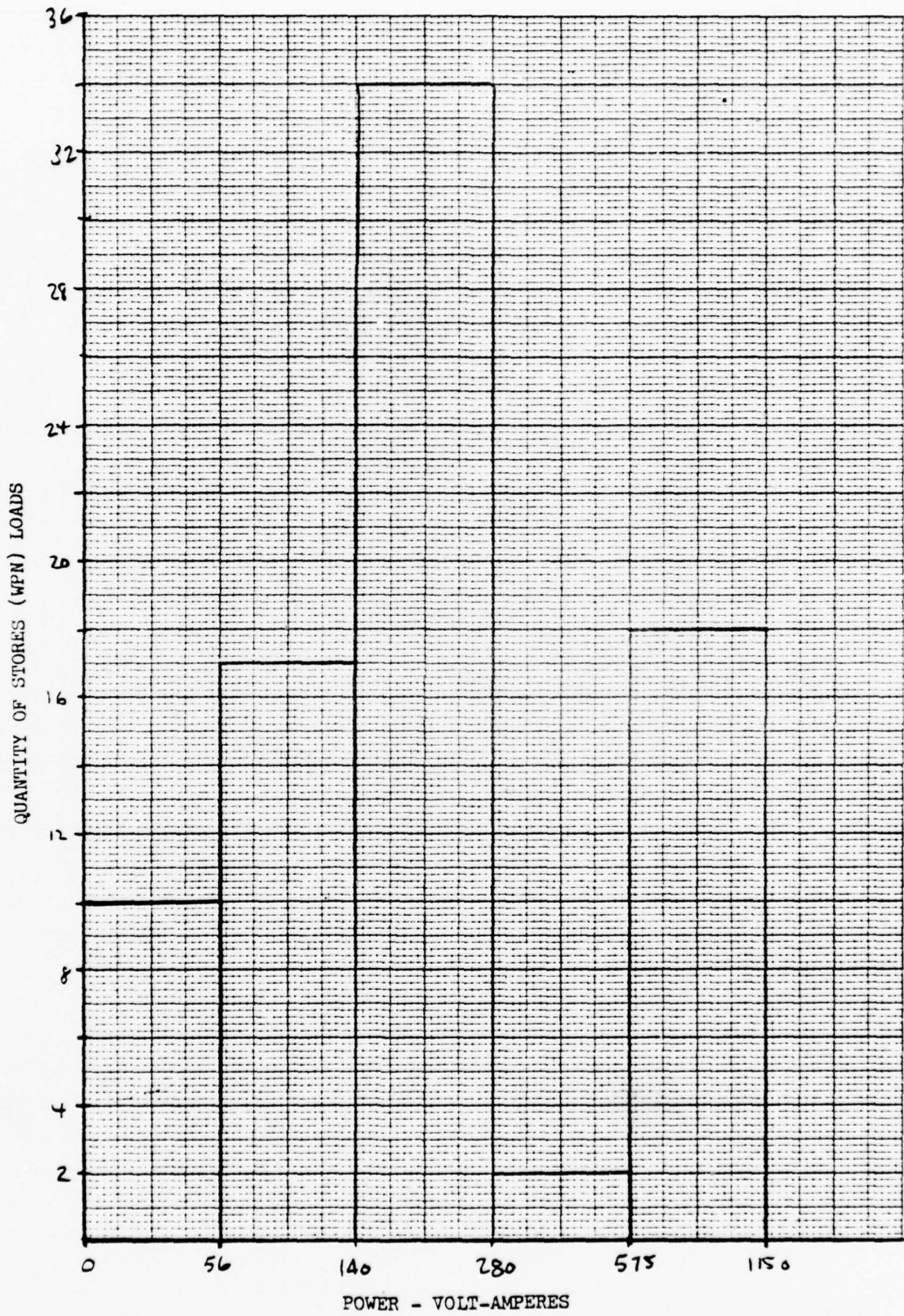

FIGURE 10 WEAPON LOAD DISTRIBUTION
302

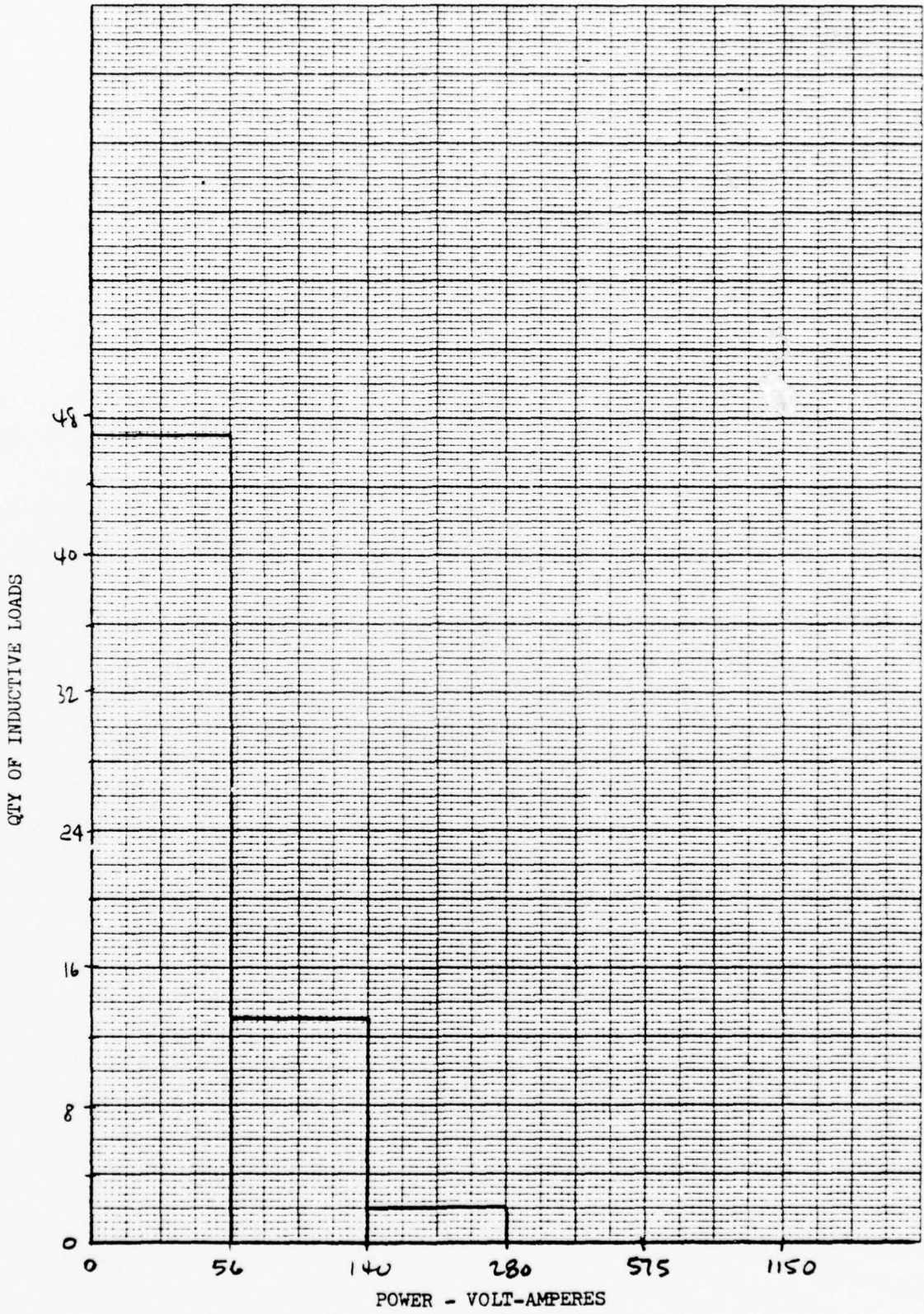

FIGURE 11 INDUCTIVE LOAD DISTRIBUTION
303

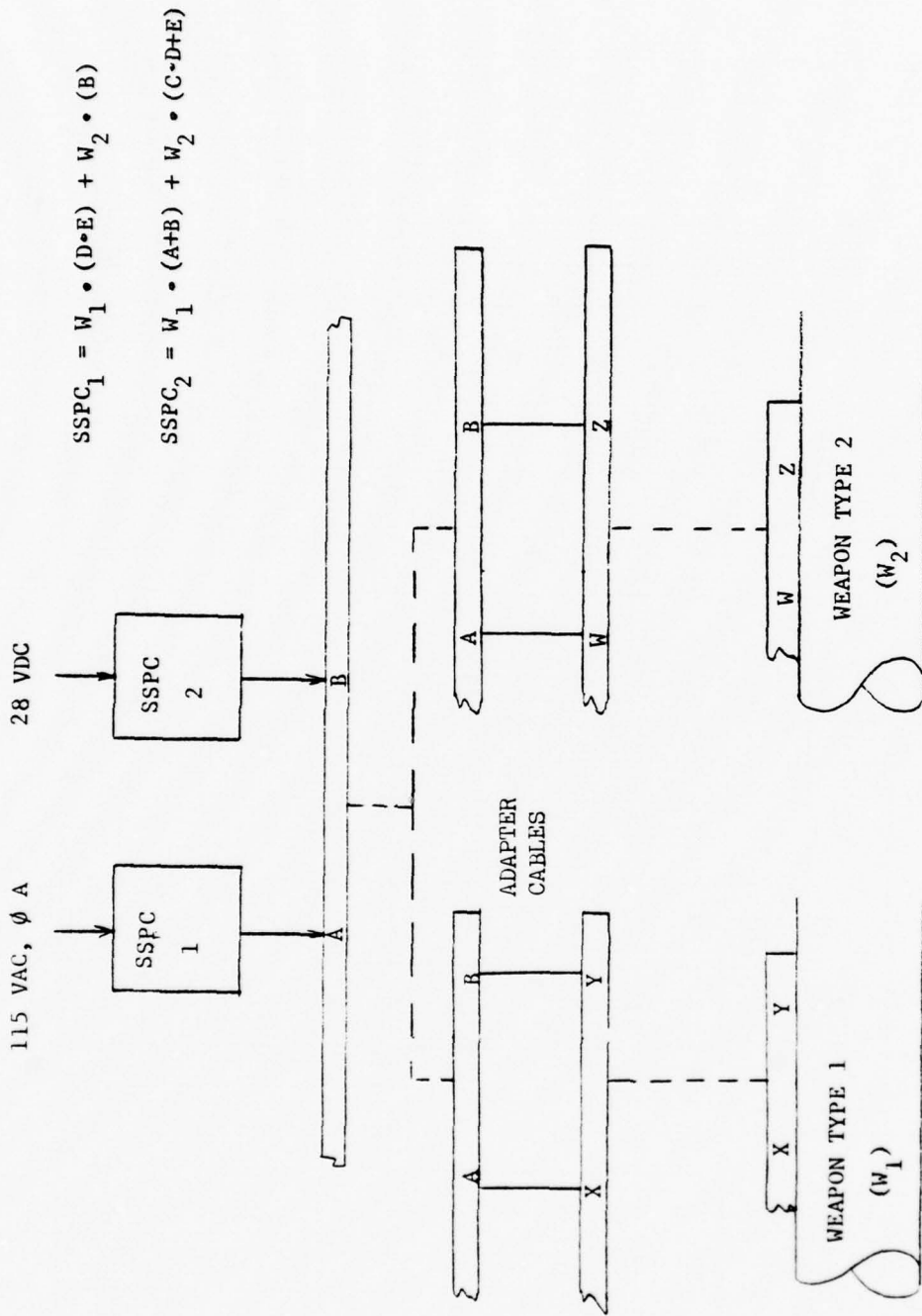

FIGURE 12: WEAPON STATION SSPC SHARING

weapon, SSPC No "X" may power a motor while for a different weapon, the same SSPC may power a resistive load. The loads shown in Figure 10 are representative of the mix of SSPC power ratings required to implement this SSPC sharing scheme on the A-7 attack aircraft. The A-7 weapon configuration consists of 6 general purpose external store stations, two special purpose (sidewinder) store stations and one internal cannon.

The next three figures illustrate the distribution for 115 volt, 400 Hertz loads (Figure 13), the 28 volt dc loads (Figure 14), and 26 volts, 400 Hertz instrument bus loads (Figure 15). These figures depict load distribution as a function of current required from the respective SSPC. Current divisions are shown in increments representative of potential SSPC current ratings.

While Figure 15 summarizes the current vs quantity distribution for all 26 volt ac loads, the figure also depicts the specific load type, i.e., synchro and small motor devices. This results from restricted load quantity and type indicative of instrument power distribution systems.

Figures 16 through 23 illustrate the spread of load current requirements for 115 volt, 400 Hertz and 28 volts dc power. The figures show these load current distributions as a function of major load category. It should be noted that with the exception of weapon loads, the load quantity generally increases as the load current decreases. The percent of total 400 Hertz and 28 volt dc loads which require less than 0.5 amperes is 49 percent and 30 percent, respectively.

2.2.1 SSPC Ratings

The mix of available power controller ratings is influenced by several factors:

POWER - VOLT-AMPERES

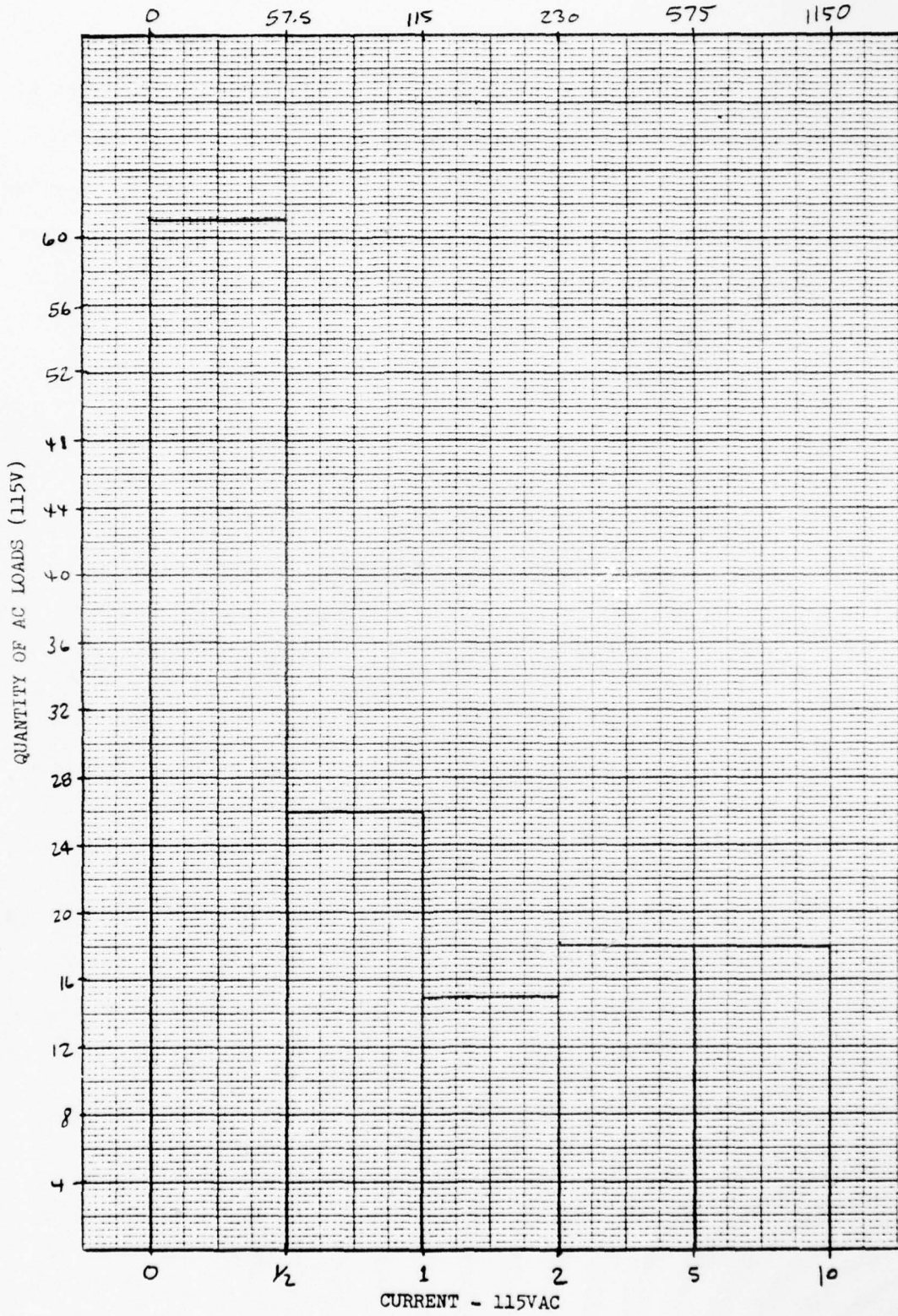

FIGURE 13 115VAC LOAD DISTRIBUTION
306

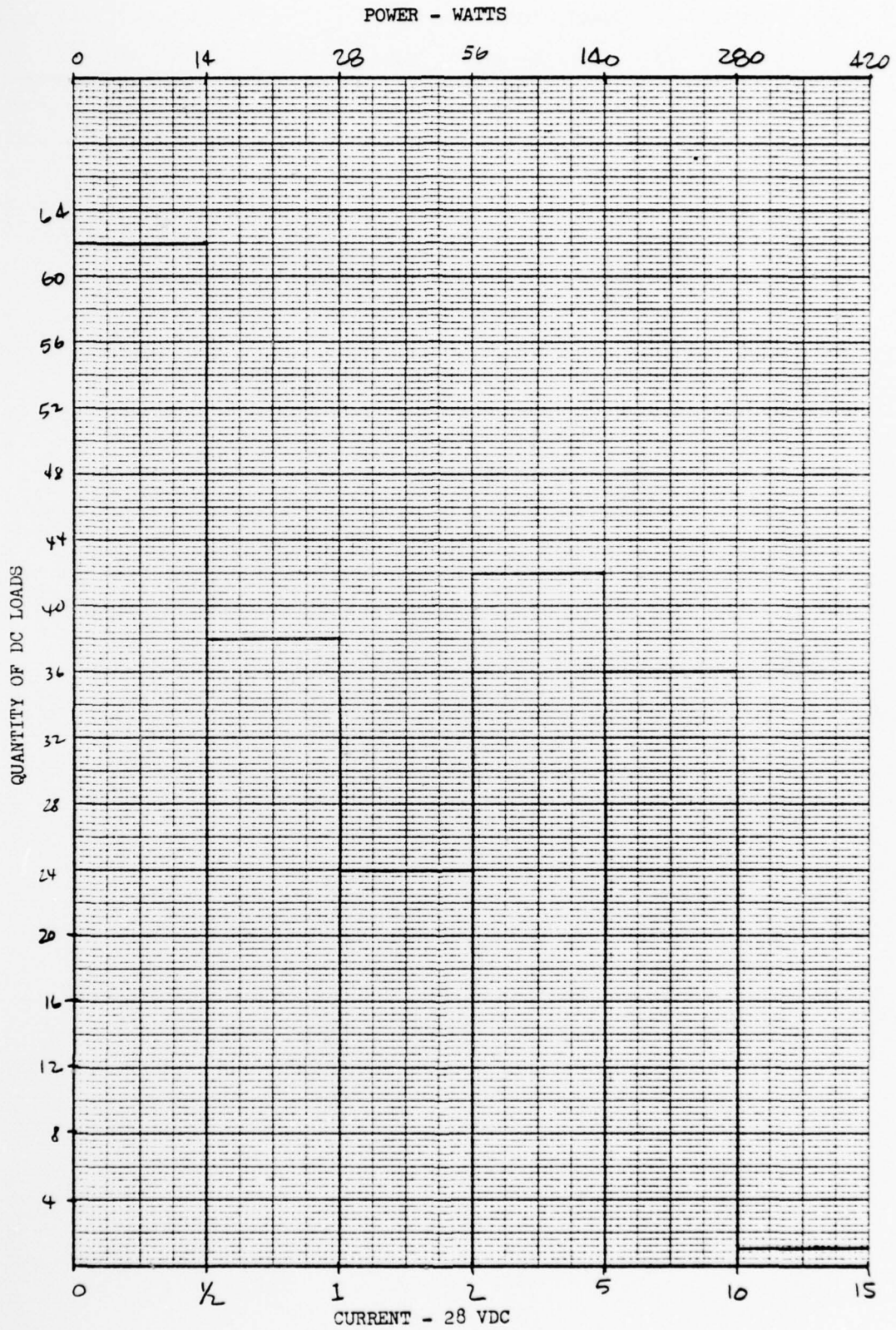

FIGURE 14 28VDC LOAD DISTRIBUTION

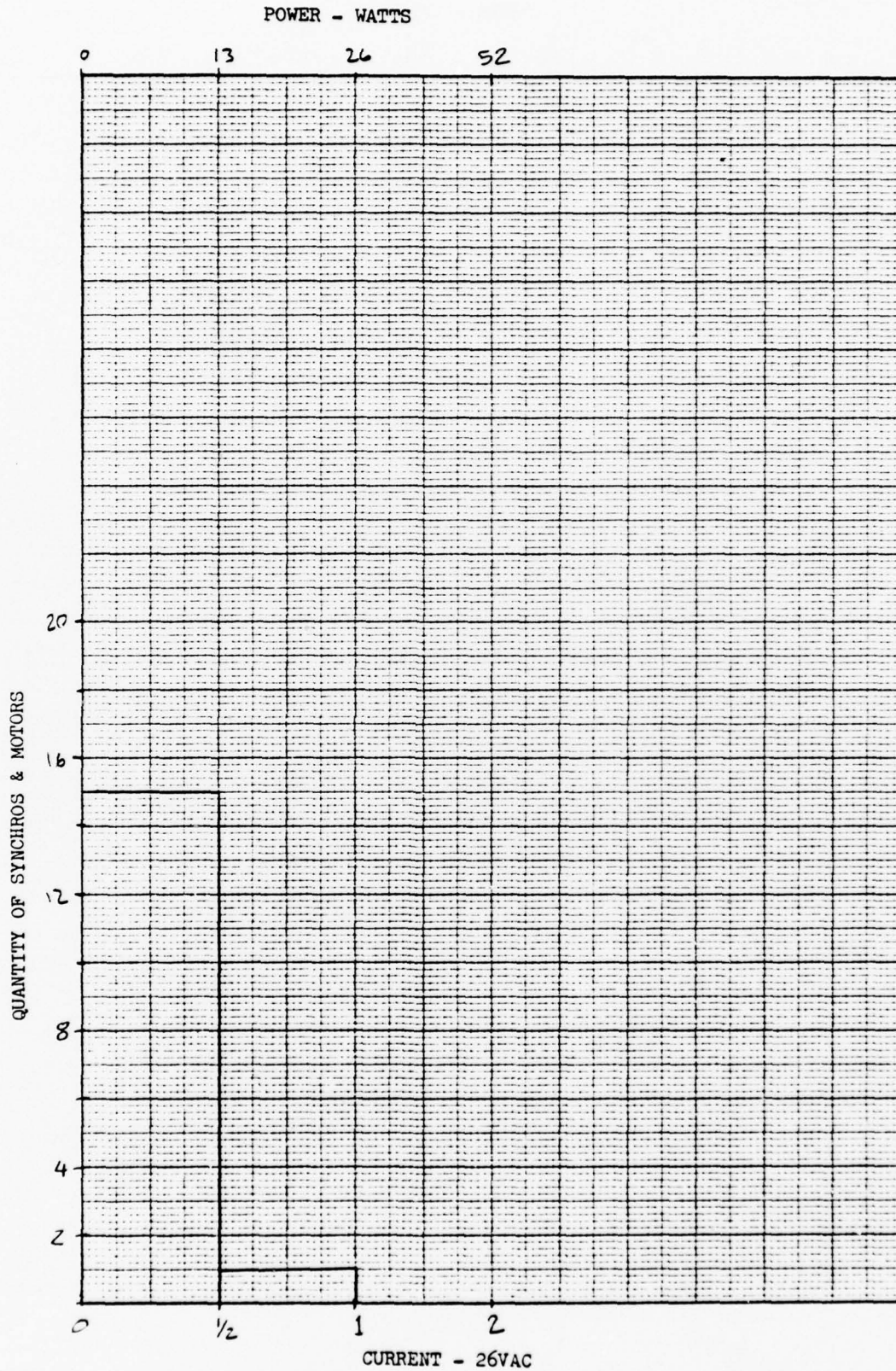

FIGURE 15 26VAC LOAD DISTRIBUTION

POWER - VOLT-AMPERES

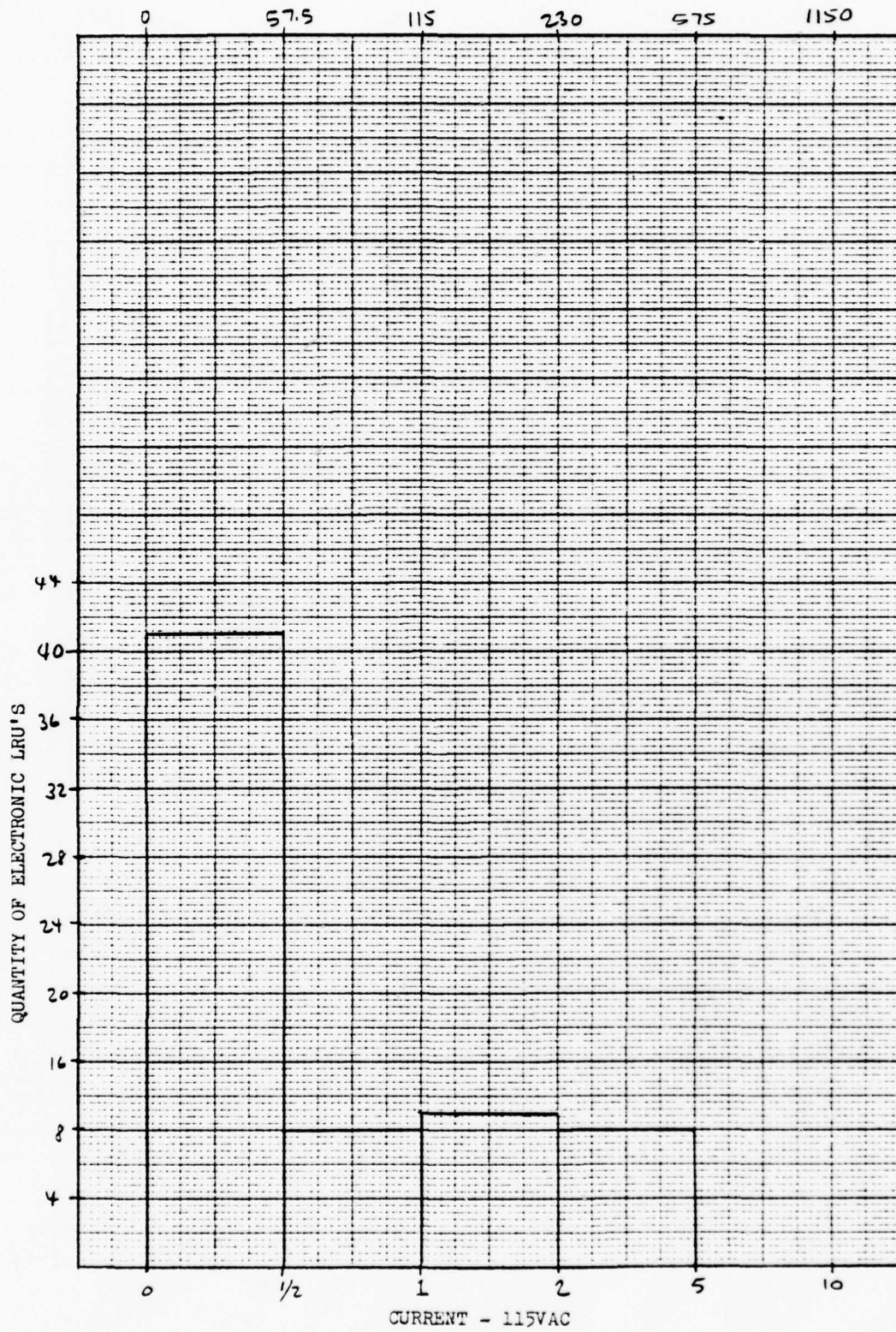

FIGURE 16 115VAC ELECTRONIC LRU LOAD DISTRIBUTION
309

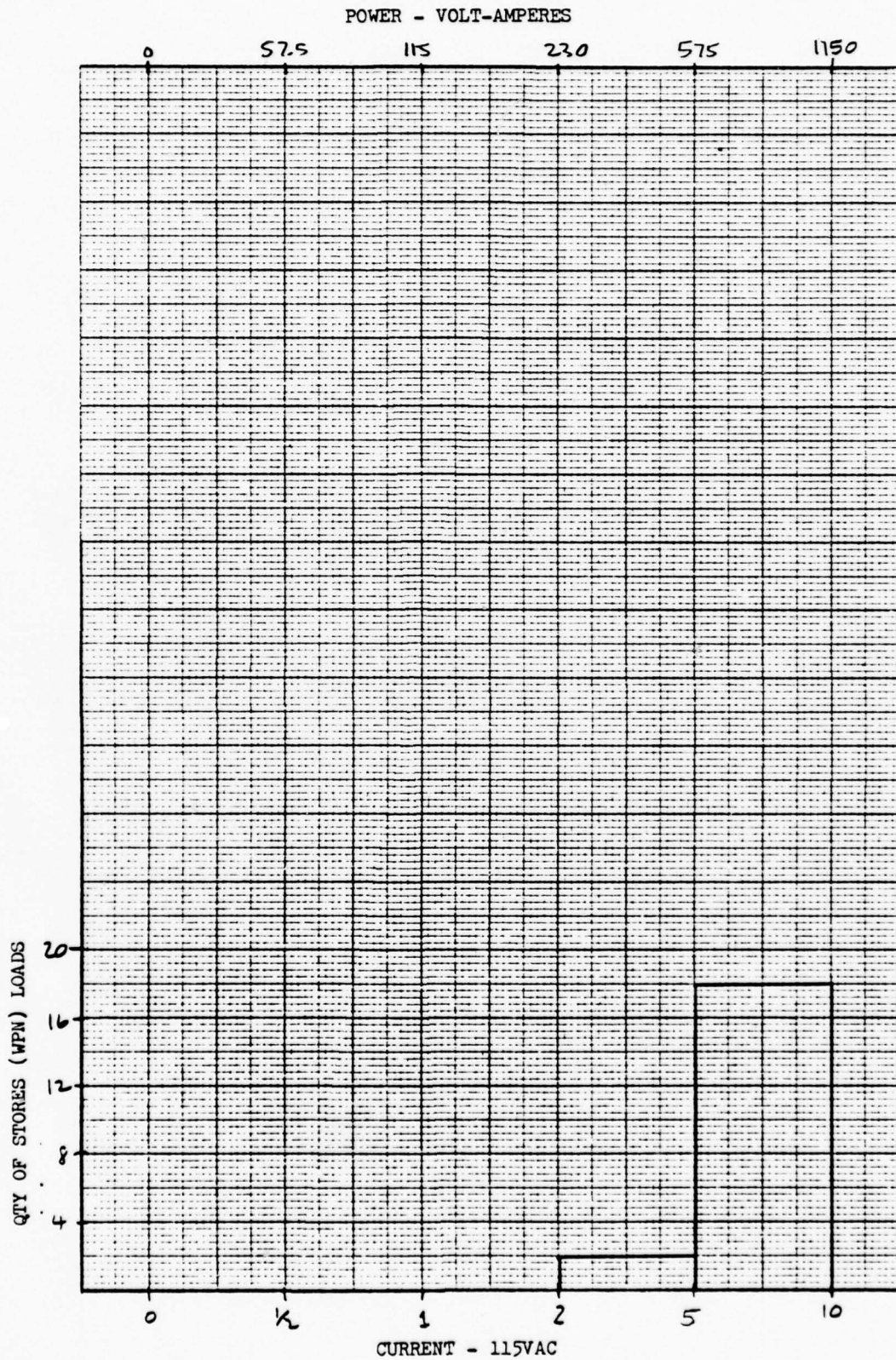

FIGURE 17 115VAC WEAPON LOAD DISTRIBUTION

POWER - VOLT-AMPERES

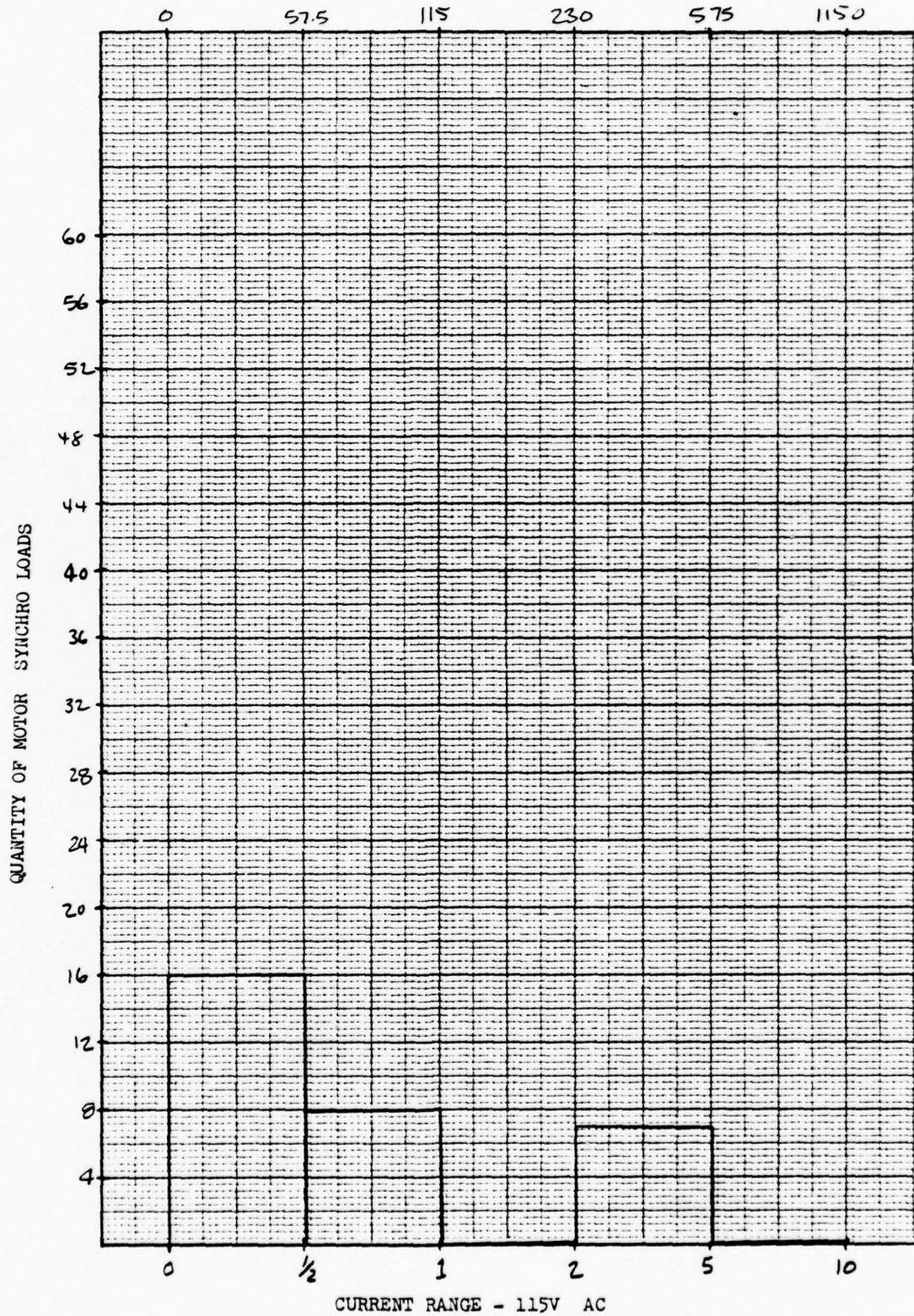

FIGURE 18 115VAC MOTOR LOAD DISTRIBUTION
311

POWER - VOLT AMPERES

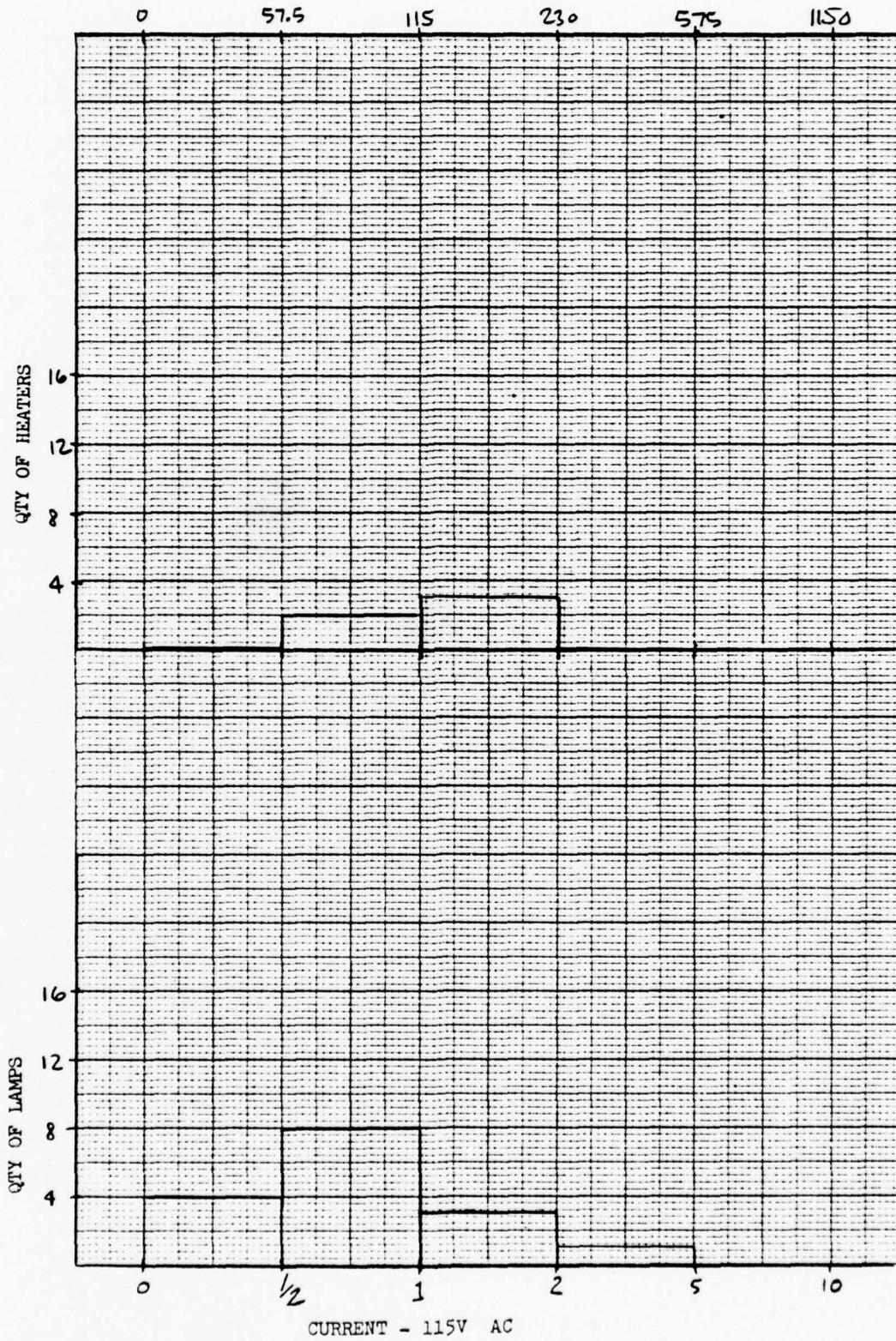

FIGURE 19 115VAC LAMP AND HEATER LOAD DISTRIBUTION
312

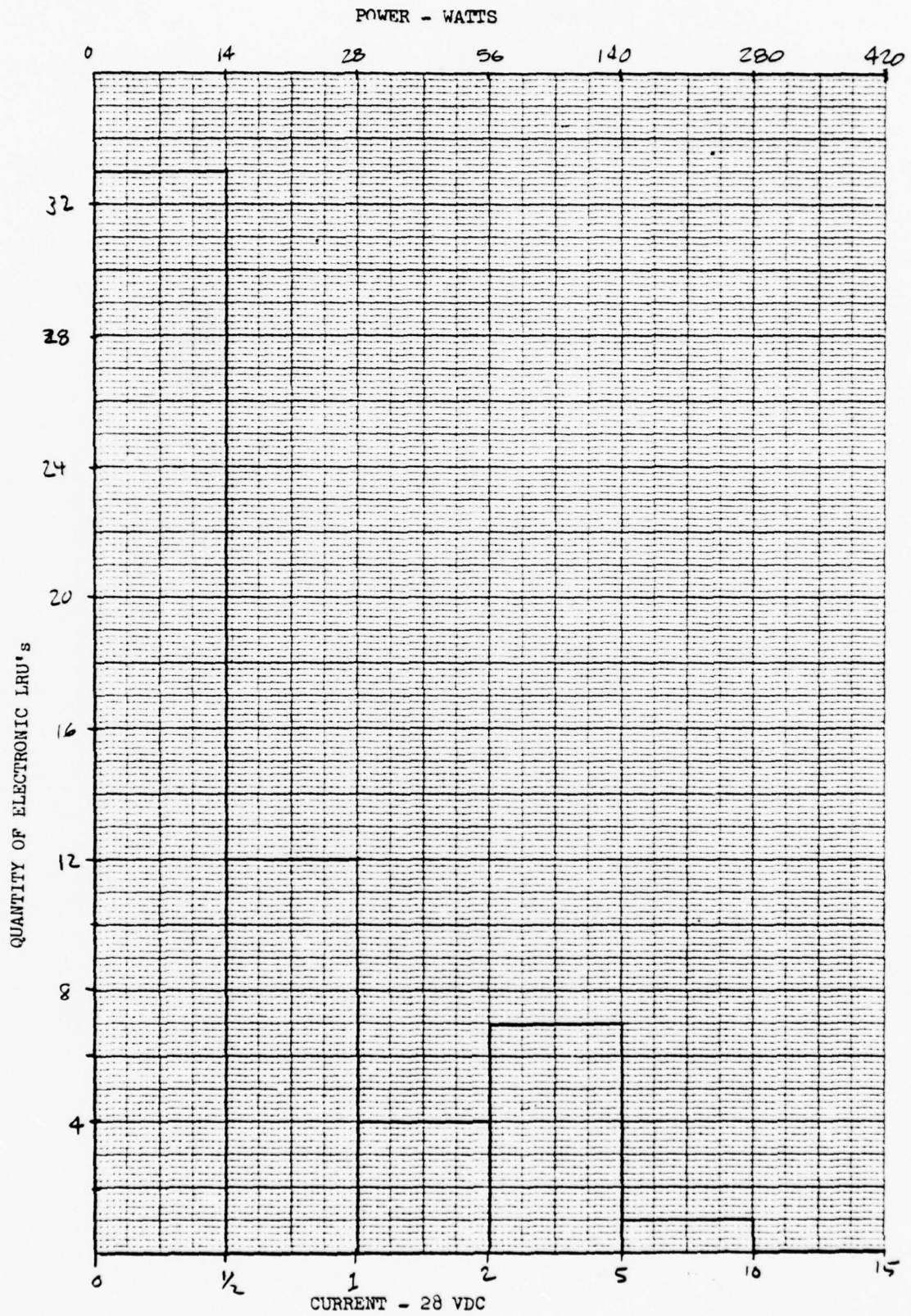

FIGURE 20 28VDC ELECTRONIC LRU LOAD DISTRIBUTION
313

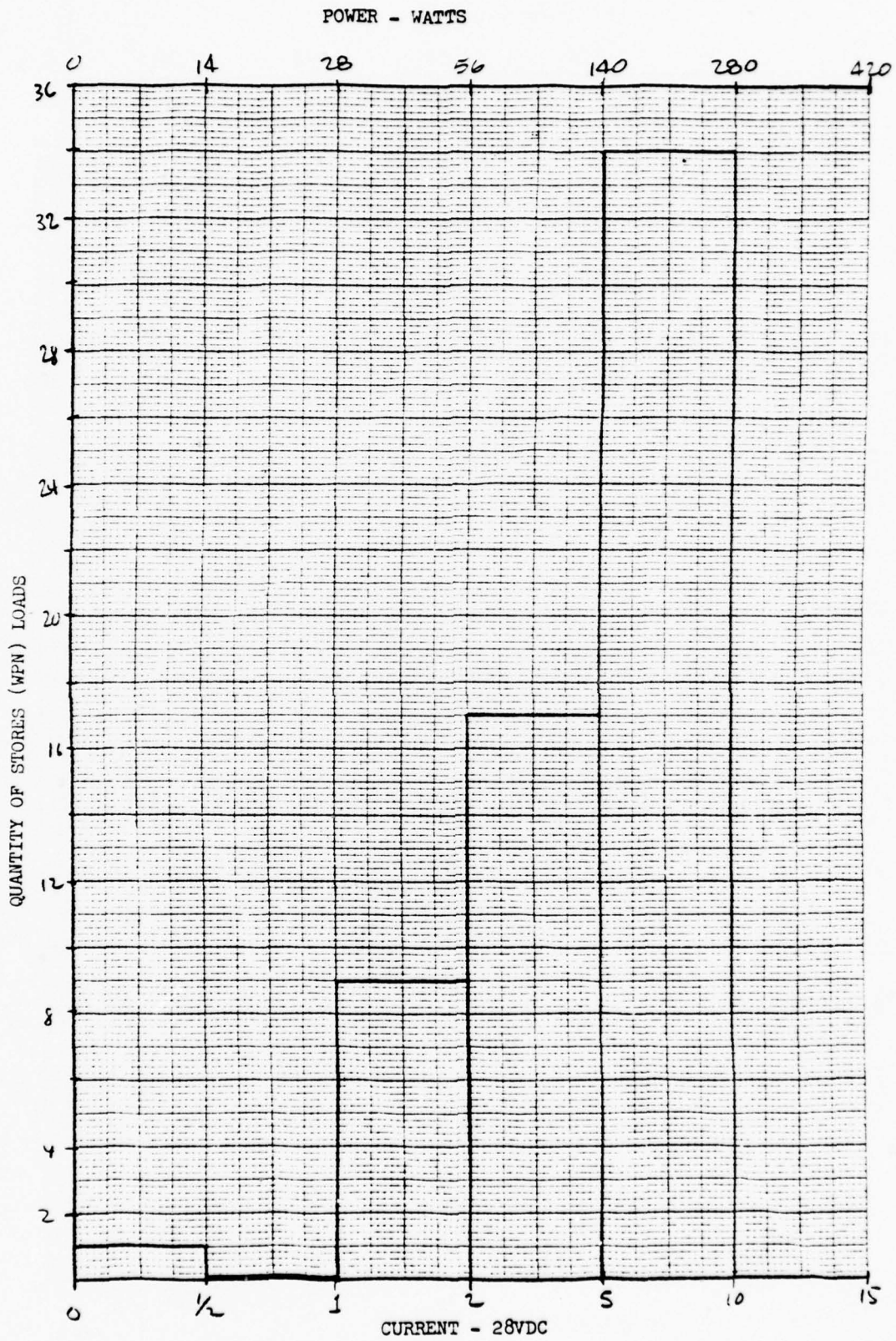

FIGURE 21 28VDC WEAPON LOAD DISTRIBUTION

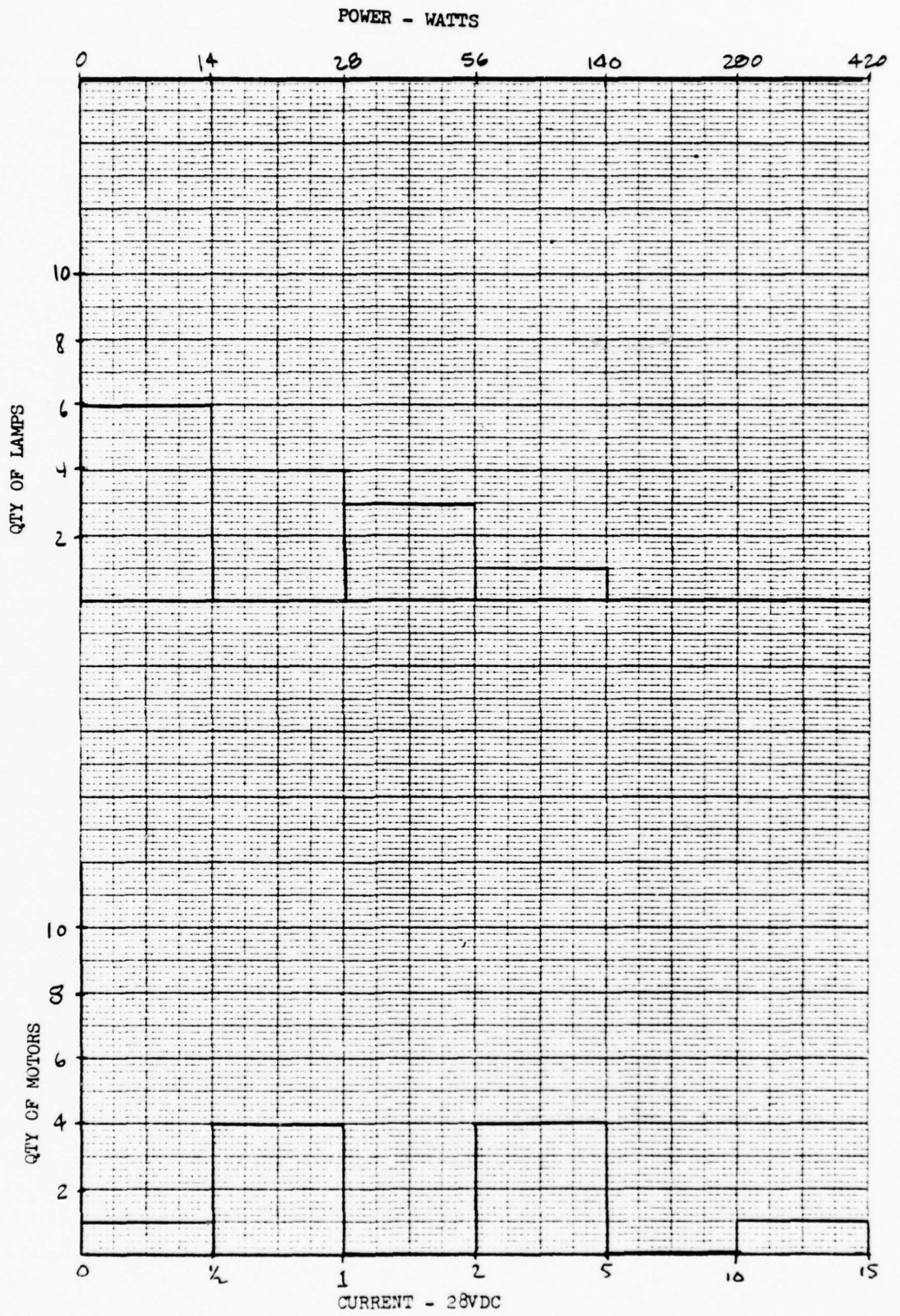
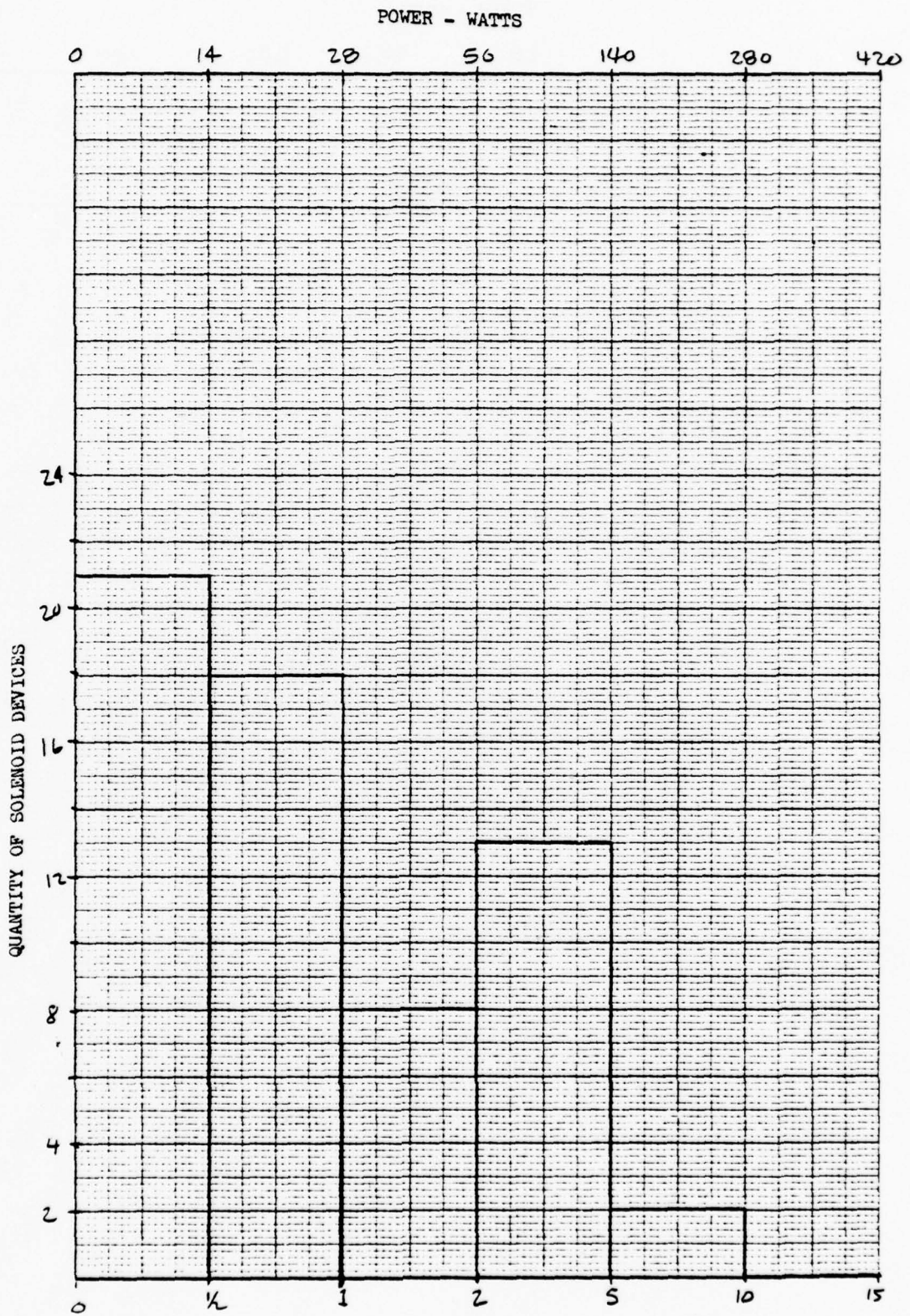

FIGURE 22 28VDC MOTOR AND LAMP LOAD DISTRIBUTION



CURRENT - 28 VDC
 FIGURE 23 28VDC SOLENOID DEVICE LOAD DISTRIBUTION

- 1) Current capacities of available wire gauges
- 2) Built-in-Test capability/sensitivity of SSPC
- 3) Multichannel vs single channel SSPC
- 4) Logistics considerations

2.2.1.1 Current Capacity of Available Wire

One approach to selecting power controller ratings is to assign a current trip level which matches the current rating of the various wire gauges. Table 1 lists current ratings of military grade "airframe" wire. These ratings are representative of design limits used for wire harness bundles exposed to MIL-E-5400 environments. The ratings assume use of conductors with 150°C or 200°C rated insulations as indicated in the table. Typical insulation ratings available are 105°C, 150°C and 200°C. Use of wire smaller than 24 gauge requires specific approval of the procuring activity.

The current capacities in the table were calculated based on simultaneous occurrence of the high temperature and altitude. This assumption adds safety margin to the wire ratings since it is extremely difficult to develop an environment which simultaneously has maximum temperature and maximum altitude.

It is desirable from a weight and volume viewpoint, to use the smallest wire gauge possible for each application. The smallest wire gauge is determined by current capacity needs, maximum allowable line voltage drop and mechanical strength requirements. The impact of voltage drop considerations on wire gauge can be seen in Table 2. The table shows the maximum current for various gauges as a function of power wire length (including power return) and MIL-E-5400 environments. Since a typical minimum wire length (power wire plus power return wire) for most aircraft applications will be 10 feet total, the associated current ratings of Table 2 will be used for each wire gauge in the discussion which follows. In addition, gauge limitations presently imposed by the military restrict the use of wire to 26 gauge or

TABLE 1
 CURRENT CAPACITIES* OF MILITARY
 AIRCRAFT WIRE (CONTINUOUS RATING)
 (EXCLUDING VOLTAGE DROP REQUIREMENT)

WIRE GAUGE	MIL-E-5400 ENVIRONMENT - CURRENT	
	CLASS 2 71°C, 70,000 FT. (150°C RATED INSULATION)	CLASS 4 125°C, 100,000 FT. (200°C RATED INSULATION)
14	15	13
16	12	9.5
18	10	8
20	7.5	6
22	5	4
24	4	3
26	3	2
28 (Projected)	2	1.3
30 (Projected)	1.5	1.0
* CAPACITIES CALCULATED PER MIL-W-5088F.		

TABLE 2
 CURRENT CAPACITIES OF MILITARY
 AIRCRAFT WIRE BASED ON VOLTAGE DROP (.8 VOLTS MAX)
 AND TEMPERATURE LIMITS

WIRE GAUGE	MIL-E-5400 ENVIRONMENT - CURRENT					
	(CLASS) 2 LENGTH			(CLASS) 4 LENGTH		
	5 FT.	10 FT.	15 FT.	5 FT.	10 FT.	15 FT.
14	15	15	11.61	13	13	10.3
16	12	11	7	9.5	9.5	6.5
18	10	8.6	5.75	8	7.6	5
20	7.5	5.5	3.7	6	4.9	3.2
22	5	3.4	2.3	4	3	2
24	4	2.2	1.4	3	1.9	1.3
26	2.7	1.4	.9	2	1.2	.8
28	1.6	.8	.5	1.3	.7	.5
30	1.0	.5	.3	.9	.45	.3

larger. Since most fighter-attack aircraft fit into the MIL-E-5400 Class 2 category, the class 2 current ratings will be used. Table 3 summarizes the resulting current ratings (rounded off to lowest integer) associated with various wire gauges.

2.2.1.2 Built-In-Test (BIT)

Where the power controllers contain a BIT mode which checks for current drain through the SSPC when the SSPC is commanded on, proper BIT operation will impose limitations on the range of currents supplied by any given SSPC. A good rule-of-thumb for BIT current sensor sensitivity is 10 percent of the controller rating. This indicates that use of SSPCs for loads of less than 10 percent of the SSPC rating could result in false fault indications to the EMUX processor. To minimize occurrences of false fault indications, each power controller should be rated at no less than 10 percent of its next higher SSPC rating. For example, if an SSPC is desired with a rating under a 2 ampere rated SSPC, then the lower rated SSPC should have at least a 0.2 ampere rating.

2.2.1.3 Multichannel vs Single Channel SSPC

One approach to implementing the SSPC function is to provide several power controllers on a common card or module. With this scheme, several SSPCs can possibly share common hardware, such as power supplies or a time shared I²t processor. This hardware sharing can reduce overall failure rates, system size, weight and life cycle cost.

The potential problem area with the multichannel scheme lies in the need for programmable trip ratings. For the multichannel controller to be feasible from a space utilization and logistics standpoint, the number of power controller types (voltage levels and trip ratings) must be reduced. This reduction can be attacked from two directions: (1) neutralize the effect of

TABLE 3
STEADY STATE CURRENT RATING AS FUNCTION
OF WIRE GAUGE

WIRE GAUGE	CURRENT RATING *
14	15
16	11
18	8
20	5
22	3
24	2
26	1

* For MIL-E-5400 Class 2 and 10 Feet of Wire

voltage level/frequency variations and (2) provide selectable current trip levels. The impact of various system voltage level/frequencies can be neutralized by developing a universal SSPC. This SSPC could operate from 400 Hertz ac or dc and at various voltage levels. Attempts at constructing such universal SSPCs in the past¹ indicated that performance compromises (specifically power efficiency) reduced the desirability of this approach. If the number of power voltages and frequencies used in aircraft electrical systems are reduced on the next generation aircraft (as is the trend), then the universal SSPC approach may become more feasible.

If a multichannel SSPC is implemented using a microprocessor for I^2t and BIT data processing, then it should be feasible to provide selectable current trip levels for each channel of the multichannel module. Ideally, the trip programming would occur through some scheme which would permit trip level selection at the field level. The major potential problem area in the programming approach lies in the resulting sensitivity required for the current and voltage sensors for each controller channel. If these sensors are required to operate over too broad of a range, the SSPC trip accuracy may suffer.

A first cut at rating selection for SSPC is given in the discussion which follows. The discussion covers two SSPC implementation approaches: (1) single channel SSPC module and (2) multichannel SSPC module.

An analysis was conducted to minimize system weight by varying the number of controller ratings and the current trip levels. This approach assumes no programming capability for trip level and no universal voltage/frequency compatibility.

The distribution of 115 volt ac, and 28 volt dc loads as a function of current requirements (previously shown in Figures 13 and 14 respectively) was

used to determine the rating mix of controllers for yielding a minimum weight system. The length of the power wiring from SSPC to the load was assumed constant (10 feet) for all loads. Since the weight of an SSPC varies little for controllers rated 10 amperes or below (see MIL-P-81653 detail specification sheets), the major weight contributor of significant variation is the electrical harness wires. The weight analysis therefore attempts to minimize harness weight by varying the number of controller types and the trip ratings. Shown in Table 4 are the calculated harness weights for eight SSPC mix options. These weights are then summarized and normalized in Table 5. Figure 24 is a plot of the normalized harness weights for the various numbers of SSPC ratings. As shown in the figure, there is only a 5 percent difference between the lowest weight 3 rating mix and the 4 rating mix. Due to this small difference, option 5 (10 amp/5 amp/1 amp) appears to be the best (weight wise) controller rating mix for the A-7 type aircraft.

(2) Multi-channel SSPC

Controller rating mix is not critical for multichannel SSPC's if it is assumed that programmable trip ratings are used. It should be noted that without programmable trip levels, multichannel SSPC feasibility from cost, weight and space criteria is unknown. Sufficient analysis is lacking to determine multichannel configuration and performance constraints for aircraft installation feasibility.

Since the trip level will likely be programmed by a binary code, the number of trip levels available will be 2^n . With these choices 2, 4 or 8 trip levels are reasonable (based on 1, 2 or 3 external code lines per channel). However, two levels are really not sufficient to minimize harness weight (see Figure 24) and eight levels add more complexity than may be

TABLE 4
POWER HARNESS HYPOTHETICAL WEIGHTS

OPTION	CONTROLLER RATINGS (AMPS)	X = 28 VDC WEIGHT*	Y = 115 VAC WEIGHT *	TOTAL SYSTEM WEIGHT $Z = X+Y$
1	10/5/2/0.5	36x10x.00995+ 62x10x.00243+ 62x10x.00176= 8.43 pounds	18x10x.00995+ 18x10x.00536+ 41x10x.00243+ 61x10x.00176= 4.83 pounds	8.43+4.83= 13.26 pounds
2	10/5/2	36x10x.00995+ 42x10x.00536+ 124x10x.00243= 8.85 pounds	18x10x.00995+ 18x10x.00536+ 102x10x.00243= 5.23	8.85+5.23= 14.08 pounds
3	10/5	36x10x.00995+ 166x10x.00536= 12.48	18x10x.00995+ 120x10x.00536= 8.22	12.48+8.22= 20.70 pounds
4	10/2	78x10x.00995+ 124x10x.00243= 10.77	36x10x.00995+ 102x10x.00243= 6.06	10.77+6.06= 16.83 pounds
5	10/5/1	36x10x.00995+ 66x10x.00536+ 100x10x.00176= 8.88	18x10x.00995+ 33x10x.00536+ 87x10x.00176= 5.09	8.88+5.09= 13.97 pounds

TABLE 4 (Continued)
POWER HARNESS HYPOTHETICAL WEIGHTS

OPTION	CONTROLLER RATINGS (AMPS)	X = 28 VDC WEIGHT*	Y = 115 VAC WEIGHT*	TOTAL SYSTEM WEIGHT Z = X+Y
6	10/-	202x10x.00995= 20.10	138x10x.00995= 13.73	20.10+13.73= 33.83 pounds
7	10/2/0.5	78x10x.00995+ 62x10x.00243+ 62x10x.00176= 10.36	36x10x.00995+ 41x10x.00243+ 61x10x.00176= 5.65	10.36+5.65= 16.01 pounds
8	10/2/1	78x10x.00995+ 24x10x.00243+ 100x10x.00176= 8.52	36x10x.00995+ 15x10x.00243+ 87x10x.00176= 5.48	8.52+5.48= 14.00 pounds

* WEIGHT = $\sum_{i=1}^n$ (No. of Ckts.)_i x (10 ft. of wire/ckt.) x (weight/ft. of "X_i" Gauge Wire)_i

TABLE 5
 NORMALIZED HARNESS WEIGHT FOR SSPC RATING MIX

OPTION	NO. OF RATINGS	WEIGHT	WEIGHT NORMALIZED TO OPTION 1
1	4 (10/5/2/5)	13.26	1
2	3 (10/5/2)	14.08	1.06
3	2 (10/5)	20.70	1.56
4	2 (10/2)	16.83	1.27
5	3 (10/5/1)	13.97	1.05
6	1 (10)	33.83	2.55
7	3 (10/2/0.5)	16.01	1.21
8	3 (10/2/1)	14.00	1.06

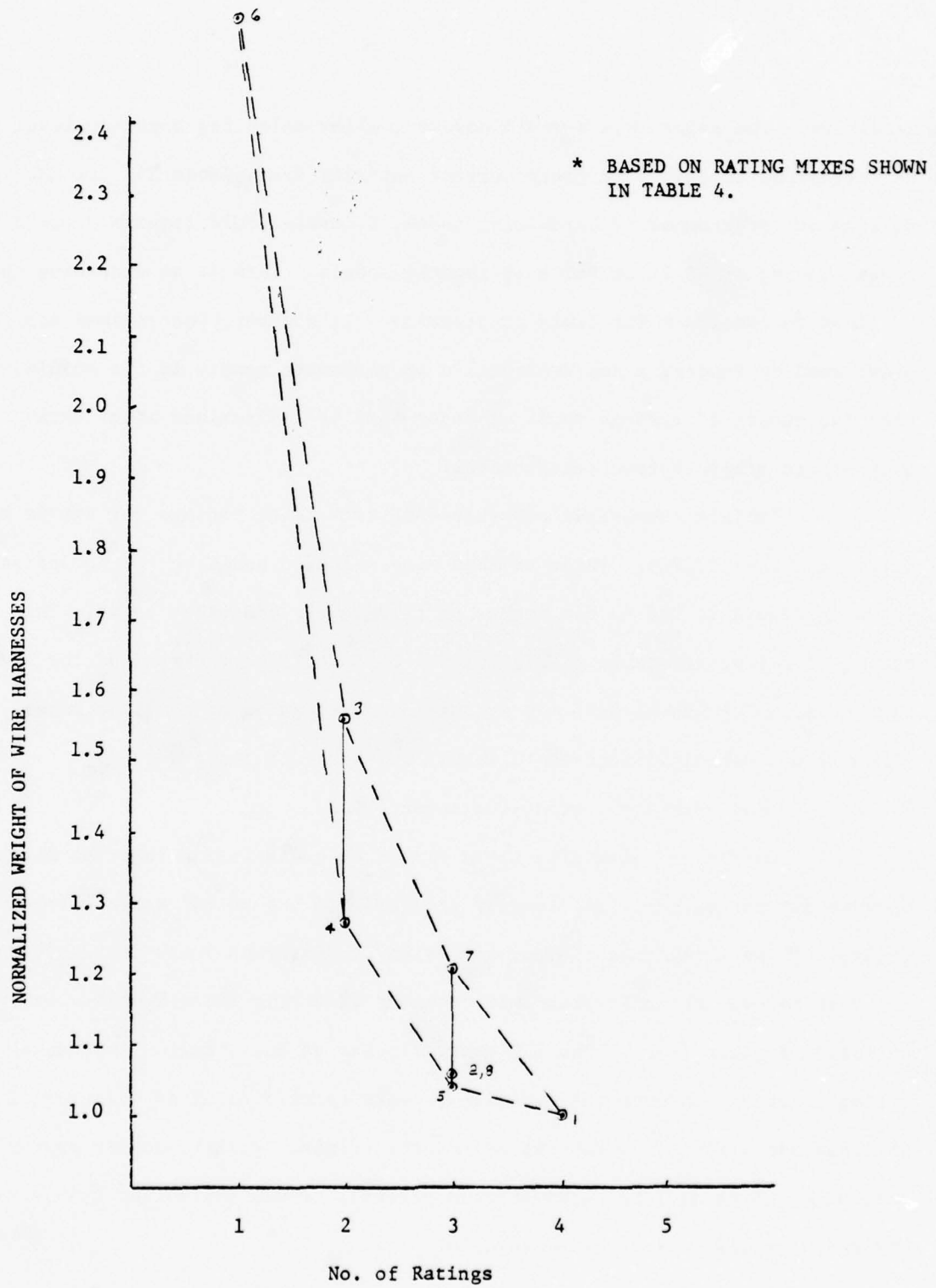

FIGURE 24: NORMALIZED HARNESS WEIGHT VS NUMBER OF SSPC RATINGS*

necessary. The eight levels would however, allow selecting a rating level to correspond to each wire gauge current capacity (ref. Table 3). If the ratings are programmed by hardwiring codes, 8 levels would require 3 codes lines/channel or 48 lines for a 16 channel module. This is an excessive number of lines to interface for field programming. If however, the ratings are programmed by loading a non-destructive programmable memory in the module, then the number of ratings would be determined by limitations other than module/aircraft interface restrictions.

Table 6 summarizes possible SSPC trip level ratings for single and multiple channel SSPCs. These ratings were selected based on rating options shown in Figure 24 and on the number of trip levels discussed above. The ratings for a programmable single channel SSPC would be the same as the hard-wire coded multichannel SSPC since field memory loading of single channel SSPCs is not practical (access to memory bus would be required).

2.2.2 Load Starting Current Characteristics

On the A-7 aircraft, there are three basic load categories which produce current surges significantly greater than the steady state current demand. These categories (lamps, motors and transformers) are discussed in the text below. An additional load category is firing conventional electro-explosive devices (EED). The EED generally has an uncontrolled impedance during ignition, however the ignition process usually requires less than 10 milliseconds. Following EED explosion, the terminal resistance may approach zero ohms due to an internally shorted circuit. Power controller trip after EED firing would however be acceptable.

Lamp, motor and transformer load current peculiarities are discussed in the three sections which follow.

TABLE 6
SSPC CURRENT RATINGS

SINGLE CHANNEL SSPC		MULTIPLE CHANNEL SSPC	
NON PROGRAMMABLE	PROGRAMMABLE	HARDWIRE CODING	MEMORY LOAD CODING
10	10	10	10
5	5	5	8
1	2	2	5
	0.5	0.5	3
			2
			1
			(Option) 0.5
			(Option) .20

2.2.2.1 Lamps

The theoretical worst case inrush current for tungsten filament lamps is limited to 20 times (28 times if lamp is turned on at peak of ac cycle) steady state current by the melting point of tungsten (3655°K). Actual inrush is limited by impedance (resistive and inductive) of the lamp circuit and filament. The maximum inrush generally varies from 8 to 17 times the normal steady state current. The duration of inrush varies with lamp size (i.e., rating). The inrush current peak is generally reached within 2 milliseconds for all lamp types typically used in aircraft applications. In addition, the current typically returns to the steady state level within 20 to 200 milliseconds.

2.2.2.2 Motors

The worst case motor starting current or stall current is determined by the dc resistance of the motor windings. If the motor is operated from an ac power source, the stall current is also limited by the motor reactance. For the A-7, the worst ac motor stall current condition (relative to the normal running current) occurs in the avionic bay fans. The locked rotor current for these fans (115 volt, 400 Hz, 3 phase) is approximately 790 percent of the normal running current (2.08 amperes/phase). The duration of this stall current will be indefinite if the motor should stall. The duration of the inrush current for motor starting is approximately 0.6 seconds. In addition, these motors are required to continue operation after loss of one power phase. When operating from any two of the three phases, the running current is approximately 5.5 amperes/phase (264% of normal current) continuously.

The worst case A-7 dc motor current transient occurs in a rotary type power inverter. This unit (MS21983-1) has a 250 VA rating but the maximum

load applied in the A-7 application is 123 VA. This load results in continuous 28 volt dc input current of 11 amperes when the inverter is powered. However, the starting current (or no speed current) is determined by the inverter full load rating. This current was measured to be 112 amperes peak (1020% of normal current) at 28 volts and decays to 20 amperes in approximately 2 seconds. If the inverter is fully loaded (250 VA), the peak current is the same 112 amperes, but is only 430 percent of the steady state input current. The current delay time also increases under full load conditions from 2 seconds to approximately 3 seconds.

2.2.2.3 Transformers

Transformers have long been known as sources of high inrush currents. The inrush currents are due to driving a transformer into saturation shortly after turn-on. Saturation can occur if the transformer is energized at a time in the voltage cycle such that the voltage change will increase the residual flux rather than decrease the flux. If the transformer goes into saturation, the resulting input current will increase to an upper value limited by the transformer dc resistance. In 400 Hertz applications, this peak current will last less than 1 millisecond but will repeat every 2.5 milliseconds as it gradually decays to the normal current value. The current usually returns to the normal level within 10 milliseconds.

Analysis of data on transformers used on the A-7 indicate a peak saturation in-rush current of 50 to 130 times the steady state rms input current for the transformer at rated load. These transformers are step down devices in the 40 to 200 VA rating range. Analysis of similar data on MIL-T-27 transformers of the type used on other military aircraft indicate a peak saturation in-rush

current of 34 to 370 times the steady state rms input current. These transformers are rated at .05 to 60 VA. The ratio of inrush to steady state current is determined more by the output voltage regulation requirement of the transformer than by the transformer rating for large transformers (50 VA or greater). In addition, small transformers (below 10 VA) will often have high in-rush current ratios (i.e., above 100) not due to voltage regulation requirements, but due to the relatively low input impedance of a transformer winding when compared to the high impedance secondary load.

The transformer in-rush current should not cause a load compatibility problem if current limiting is incorporated into the SSPC. Reduction of the in-rush current by incorporating zero voltage turn-on and zero current turn-off into the SSPC only reduces the in-rush current by a factor dependent on the phase angle between the transformer primary voltage and current. This phase angle is determined by the phase angle of the secondary load and by the transformer losses.

3.0 SSPC CONFIGURATION TRADE AND ASSOCIATED COST IMPLICATIONS

Several aspects of the SSPC configuration significantly impact the aircraft electrical system life cycle cost. These configuration aspects include:

- o The SSPC/EMUX electrical interface
- o The SSPC termination method
- o The installed weight of the SSPC including the EMUX interface
- o The SSPC control/termination reliability and maintainability

Each of these configuration variables are discussed in the following sections.

It is noted that the "quantitative" discussions on cost are based on A-7 or similar complexity aircraft. The life cycle cost calculations assume 675 aircraft operated for 10 years at 35 flight hours per month per aircraft and are based on electrical system cost sensitivities developed for the A-7 ALOFT program.²

3.1 SSPC/EMUX Interface

Various interface types have been proposed in previous studies for the SSPC to EMUX interconnection. These interfaces can be divided into four basic categories:

- (1) A dedicated wire interface per control/monitor function for each SSPC channel
- (2) A two wire multifunction interface for each SSPC channel
- (3) A serial data channel interface for multichannel SSPC module
- (4) Integration of multichannel SSPC into the EMUX terminal.

Each interface type is discussed in the following paragraphs. Additional rationale concerning requirements and comparisons of SSPC input/output signal interface requirements is discussed in Paragraph 4.0.

3.1.1 Dedicated Wire Interface

One approach to implementing the SSPC/EMUX interface requires a dedicated wire between the SSPC and EMUX terminal for each SSPC control or monitor function. The number of functions can typically vary from two to five.

These functions, in sequence of decreasing priority are:

- (a) On/Off control input
 - (b) Trip output
 - (c) Status output
 - (d) Lockout input
- and (e) Reset input.

Most SSPC configurations of recent years have eliminated the reset input since this function can easily be accomplished by cycling the on/off control input. For this reason, the reset interface function will also be dropped in this study.

The lockout interface function has been proposed in the past to provide some degree of redundancy in the control of the SSPC "on" state (or in some cases to provide a "hardwired" AND function). Serious consideration should be given to the predominate failure modes of the power controller and EMUX system when evaluating the effectiveness of lockout derived redundancy. Additionally, it is believed that most cognizant agencies will be very slow in approving lockout as a technique for achieving fail safe redundancy in critical aircraft systems (e.g., squib fired devices, nuclear weapon control/release, landing gear retraction, etc.). For this reason, the value of providing lockout in SSPC's is marginal at best, especially when considering the desire to minimize controller complexity.

The next three interface functions (on/off control, status, and trip) are closely interrelated. Obviously on/off control input is required.

Also, the status output is desired to monitor the health of the electrical system. Past studies have proven the significant advantages of automated self test on the maintainability (and hence, the life cycle cost) of complex aircraft systems. The status output from each SSPC is the first (and possibly most significant) step in achieving self test for electrical systems. For this reason, the SSPC should have, as a minimum, a control input and status output.

The trip output provides extra information which refines the knowledge on SSPC circuit status. Some of this gained knowledge could be derived by EMUX processor logic manipulation of available SSPC control and status data. This, however, places an added burden on the processor (time and memory for calculating trip status of each power controller). In addition, derivation of the trip state in the processor through use of control and status data could result in two major errors:

- (a) Indicate a trip condition when the failure is actually caused by intermittent or continuous opens or shorts in interconnecting wires or associated components.
- (b) Greater uncertainty as to actual controller trip or failure status.

For the above reasons, incorporation of the trip output into the controller is the desired approach. A major reason that trip output is occasionally deleted in the aircraft system implementation results from its impact on EMUX terminal channel quantities. For each monitor/control function included in the SSPC/EMUX interface of the dedicated wire approach, one EMUX terminal channel is required. If, for example, the A-7 requires approximately 400 power controllers, the difference in terminal channel requirements between a control/status interface (300 channels) and a

control/status/trip interface (1200 channels) is 400 channels. This difference is equivalent to over six additional 64 channel EMUX terminals. Likewise, adding the status monitor function requires an additional six EMUX terminals. It can be seen, therefore, that a major problem with the dedicated wire interface approach lies in its impact on EMUX channel terminal requirements.

An additional problem of the dedicated wire approach results from wire harness complexity. If it is assumed that the average wire length within a Load Management Center is two feet and that 24 gauge wire (e.g., M22759/17-24) is used, the control/status/trip interface will require approximately 0.024 pounds of wire per SSPC. The weight is derived as follows:

$$\text{Wire WT} = 2 \text{ ft of \#24 wire} \times 0.00243\text{\#/ft} \times 5 \text{ wires}$$

$$\text{Wire WT} = 0.0243 \text{ pounds}$$

The five wires is based on each SSPC having a control, a status, a trip and two signal return wires (one return required for control and one return for status/trip monitor functions based on the president set by the B-1 application). The total harness weight will include wire weight plus connector weight. Ignoring, for the present, the termination technique at the SSPC, the weight of connectors at the EMUX terminal is approximately:

$$\text{CONN WT} = 5 \text{ contact sets/SSPC} \times 0.033 \text{ lbs/contact set}$$

$$\text{CONN WT} = 0.165 \text{ \#/SSPC}$$

The weight for each contact set was derived from MIL-C-38999 high density connector (MS27466E23 and MS27467E23) weight data. The total harness weight is approximately 0.189 pounds/SSPC (0.024 pounds of wire plus 0.1650 pounds of connectors). For 400 SSPCs (approximate A-7 quantity required), the interface harness weight is 75.6 pounds. Eliminating the trip monitor function reduces the weight to 60.5 pounds (75.6 lbs/5 wires x 4 wires), i.e., a twenty percent reduction. Eliminating all monitor

functions (or use of the two wire control system) yields an interface harness weight of 30.24 pounds (75.6 LBS/5 wire x 2 wires).

The total weight impact of the interface includes the EMUX terminal weight penalty as well as harness weight. Since the terminal channels and associated wire interface for implementing the on/off control is required for all SSPC's, this hardware weight will be used as the baseline weight. This baseline weight is approximately 30.24 pounds for 400 SSPC harness interfaces plus 20.32 pounds for EMUX terminals (3.2 LBS/63 channels x 400 channels) for a total of 50.56 pounds. Table 7 compares the baseline weight to system weights using control/status and control/status/trip interfaces.

TABLE 7
CONTROL SIGNAL INTERFACE WEIGHT COMPARISONS

Approach	Weight (Lb)			Normalized Wt (Total)
	Harness	Terminal	Total	
On/Off Control Only (Baseline)*	30.2	20.3	50.5	1.00
Control/Status	60.5	40.6	101.1	2.00
Control/Status/Trip	75.6	60.9	136.5	2.70

* No Built-In-Test Capability

As can be seen, a significant weight penalty is imposed on the aircraft electrical system by the type of dedicated wire interface selected. These weights are used in paragraphs 3.1.2 and 3.5 for comparing costs of various interfaces.

3.1.2 Two Wire Multifunction Interface

By replacing the bi-level signal characteristics used in the dedicated wire interface discussed above with a "five" state signal, more

information can be transferred over a single signal interface wire set. Figure 25 illustrates the signal level definitions for a multi-level signal interface. The signal interface is implemented by the EMUX terminal sending a constant current signal to the SSPC. The voltage (or impedance) reflected back to the terminal by the SSPC indicates the state of the controller. This technique also provides an exclusive voltage or impedance level for opened or shorted interface wires. The EMUX terminal therefore receives data on the state of the controller as well as the state of the wire interface, thus, yielding an expanded BIT capability. Besides expanding the built-in-test coverage, the system weight is comparable to the baseline dedicated wire system of 3.1.1 above (i.e., 50.5 pounds for 400 SSPCs) which had no self test capability. Likewise, the two wire multi-level interface yields a 63 percent lighter interface than the full-up dedicated wire interface having a degree of self test. If the choice of interfaces is only between a dedicated wire vs two-wire multilevel interface, the weight advantages indicate preference for the two wire interface. Based on the life cycle cost sensitivity to weight (7.83×10^5 \$/Lb) for the A-7,² the total cost difference between the full-up dedicated wire interface and the two wire interface is 67.338 million dollars for 675 aircraft operated for 10 years.

It should also be noted that each aircraft with the two wire interface has 1200 less wires (for 400 SSPC's) and associated terminations than the 5 wire dedicated interface. The resulting reduction in wire/termination count yields an improvement in system reliability, and hence, maintenance cost and also installation costs.

3.1.3 Serial Data Channel Interface

If multichannel controllers are developed, consideration should be given to implementing the SSPC/EMUX interface with a serial data channel.

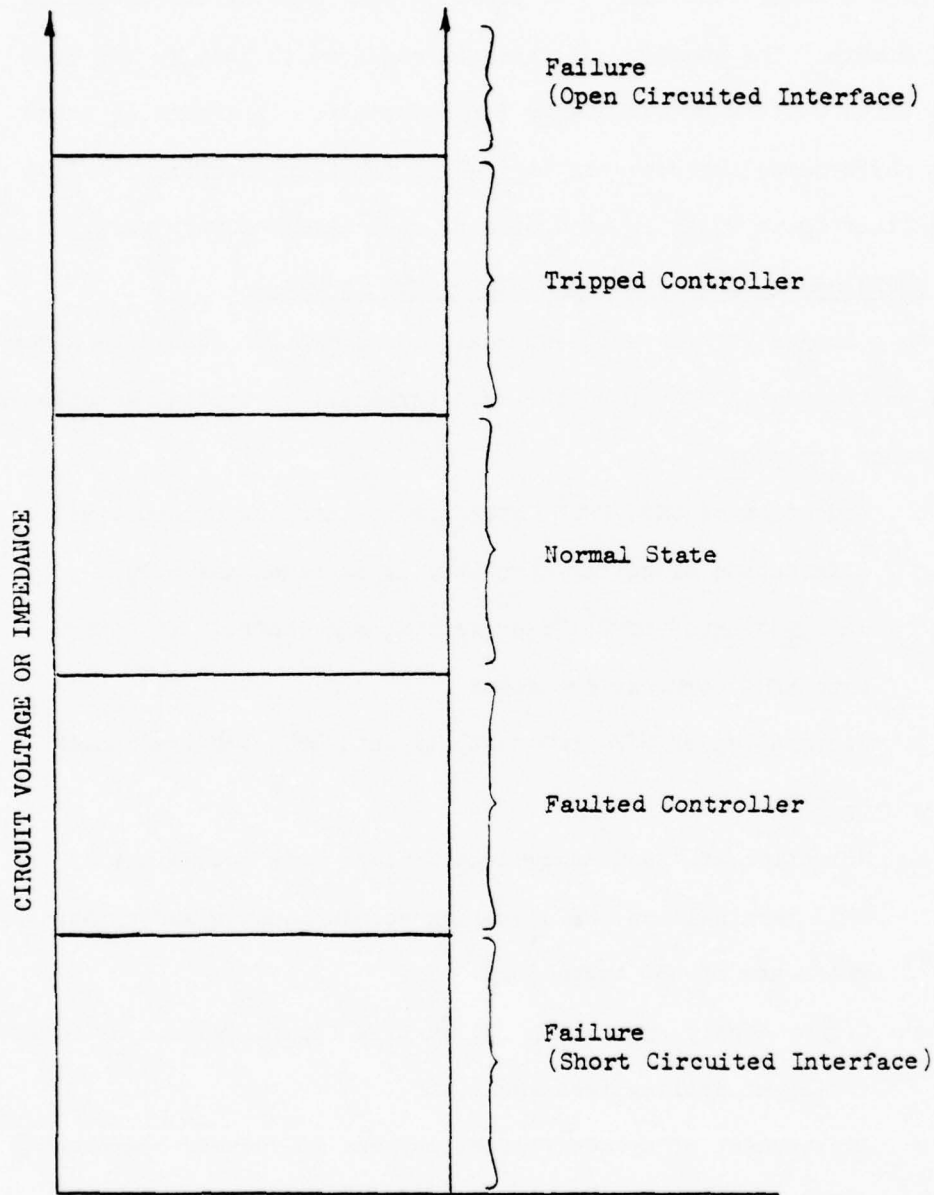

FIGURE 25 MULTI-LEVEL SIGNAL INTERFACE

Two data channels (required for minimizing impact of single failures) can be justified where a sufficient number of power output channels are installed in one SSPC module. The quantity of channels required to justify the dual serial data lines must be determined by further study. It should be noted that system performance improvements may result from implementing the data line with a fiber optic cable in lieu of a twisted shielded wire pair.

3.1.4 Multichannel SSPC Integrated Into EMUX Terminal

As a longer term development goal, consideration should be given to integrating multichannel SSPCs into the EMUX terminal. Potential advantages of this approach include:

- o Reduction of SSPC/EMUX interface to intrabox connections
- o Elimination of buffer circuitry at terminal and SSPC
- o Integration of SSPC I²t processing and control circuitry into EMUX terminal processor
- o Integration of SSPC power supply into EMUX terminal power supply
- o Reduction of "Load Management Center" size and weight by EMUX terminal and SSPCs sharing common housing and through wider use of LSI technology.
- o Higher density packaging may justify (simplify) use of more efficient cooling techniques.
- o Improvement of system reliability due to reduced component and termination counts and possible lower component temperatures.
- o Programmable selection of SSPC current ratings

Potential disadvantages of terminal integrated power controllers which should be studied include:

- o Logistic costs of tailoring (and stocking) custom multichannel SSPC output modules for installation into the EMUX terminals. (This will be minimized if channel current rating can be programmed).
- o Maintenance impact of single SSPC output failure (must replace entire multichannel SSPC module)
- o EMUX location is dedicated to the LMC area (this may be an advantage or disadvantage).

It should be noted that the first disadvantage listed could be neutralized with the development of power controllers with programmable trip levels. It should also be noted that the second item listed is only a disadvantage if the replacement cost of a multichannel integrated SSPC module is higher than a non-integrated module.

3.2 SSPC Termination Technique

The optimum method for terminating power controllers depends on several application factors:

- (a) SSPC module channel capacity - i.e., single vs multichannel
- (b) SSPC expected failure rate, and
- (c) SSPC installation environment

The module channel capacity will influence the termination density. High termination densities complicate hardware replacement if termination interface must be reworked on an individual contract or termination basis (as opposed to a plug-on type). High termination density requirements restrict interconnection types to variations of plug-in techniques (e.g., pc board plug-in, crimp contact insertion, etc.).

A paramount factor which must be observed when selecting the termination method for the SSPC, is to not compromise the overall reliability

of the installed controller in order to facilitate its removal for maintenance actions (especially when the SSPC MTFB is sufficiently high that the probability for needing a maintenance action is minimal). With projected failure rates for single channel SSPCs in the 3 to 4 failures per million hour range,^{3,4} the termination system selected can become a significant contributor to total SSPC failure rate. For example, MIL-HDBK-217B projections of the failure rate for a 5 contact environmental connector (e.g., MIL-STD-1459 Common Termination System) indicates a failure rate of 0.504 failures/10⁶ hours.* This increases the basic SSPC failure rate by 12 to 17 percent. In contrast, a screw lug termination (crimp joint) system for five contacts yields a failure rate of 0.0365 failures/10⁶ hours (MIL-HDBK-217 page 2.13-2 = 5 x .0073f/10⁶ hr = 0.0365). The screw lug termination only increases the single channel SSPC failure rate by 0.9 to 1.2 percent.

The SSPC installation environment significantly impacts the termination selection. If the power controllers are to be installed within an environmentally sealed enclosure, environmental protection requirements at the SSPC terminations would be minimal. Such termination techniques as board plug-in or wire wrap would be feasible in these sealed enclosures. The sealed enclosure concept is only practical, however, for multichannel SSPCs integrated into an EMUX terminal. Enclosure volume and requirements for maintenance access will complicate sealing provisions for SSPCs which are externally mounted. For installation flexibility, SSPCs mounted outside EMUX terminals should be designed to include self contained sealing provision or facilitate simple sealing methods.

$$\begin{aligned}
 * \lambda_p &= \lambda_b (\tau_e \times \tau_p) + N \lambda_{cyc} \quad (\text{Reference MIL-HDBK-217B, sect 2.11}) \\
 &= 0.0266659 (10 \times 1.87) + 5 \times .0011 \\
 &= 0.5041522 / 10^6 \text{ hours}
 \end{aligned}$$

A study was conducted to evaluate three physical aspects of the MIL-P-81653 single channel solid state power controllers. The physical aspects evaluated are:

- (1) electrical terminations to controller
- (2) mounting provisions
- (3) installation details

The study was based on the A-7 aircraft. All installation parameters were centered around specific locations in this aircraft.

The power controller locations in the aircraft are dictated by the loads which they serve. The shortest possible wire run between the controller and the load is a very important factor in the installation of the power controllers. The limited volume and shape of the available space in the areas where the controllers must be located dictate that they be installed in a manner which will allow the most efficient use of this volume. The use of circuit card approach to installing controllers does not lend itself to the shape of this available volume. Therefore, the controllers must be configured to permit their installation in a more conventional manner. To this end, six controller termination configurations were selected for study. These configurations are shown in Figure 26 (concept F is similar to E except wire wrap post are replaced by 3/6 inch pigtails). The following table presents the advantages and disadvantages of each configuration.

Table 8 depicts a decision matrix for single channel SSPC termination selection. The resulting termination concept assignments were scaled from 1 (best) to 10 (worst) to emphasize the large separation between various concept scores. (These are not calculated values.) The screw lug terminal concept resulted in the lowest (best) score with a scaling assignment of 1. The next three best concepts (CTS, pigtails, and solder hooks) were

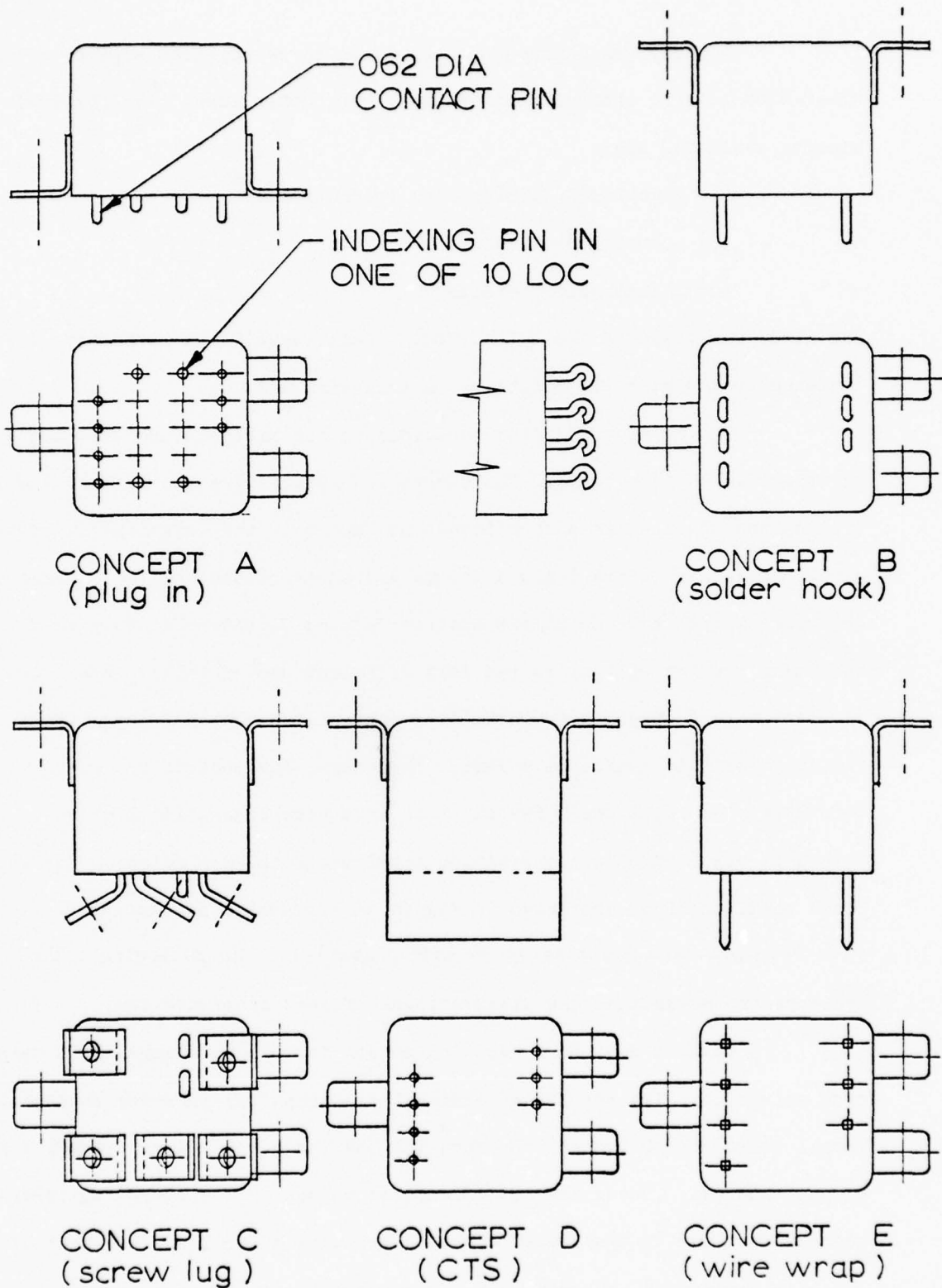

FIGURE 26 POWER CONTROLLER CONFIGURATIONS

TABLE 8
DECISION MATRIX

CONFIG	INSTL DESIGN	ELECT	MAINT	MFG	RELIB	ENVIRON	TOTAL	FINAL SCALING
A PLUG-IN	5	5	2	5	5	5	27	10
B SOLDER HOOK	3	1	5	3	3	2	17	5
C SCREW LUG TERMINAL	1	1	1	3	1	1	8	1
D CTS	3	4	3	1	3	2	16	4
E WIRE WRAP	5	2	4	5	4	3	23	9
F PIGTAILS	3	1	5	2	2	2	15	4

Rating points: 1 = most desirable, 2 = next best, etc. to 5 = least desirable

CONCEPT A (PLUG-IN)

<u>COMMENT</u>	<u>ITEM</u>
Pro	o Easiest method of replacing controller (remove mounting screws and unplug controller)
Pro	o Does not require disturbing harness in any way to replace controller
Pro	o Permits clocking of controllers to insure installing proper rated controller in mating socket
Pro	o Eliminates possibility of incurring wire errors when performing maintenance actions
Con	o Requires fabricating several close tolerance parts (mounting plate, socket board spacers, etc.)
Con	o Environmental seal required between controller and socket board (seal does not currently exist)
Con	o Connection subject to contamination, poor electrical contact
Con	o Will not permit bussing controllers together with bus bar thus increasing wiring on panel assembly
Con	o Contact area between controller and heat sink reduced by clearance holes required for pins and sockets
Con	o Vought has had bad experience with plug-in type relays which employ this type of termination
Con	o Will not permit trouble-shooting by probing terminals on controller
Con	o Requires an intermediate connector on LMC to allow production line assembly

CONCEPT B (SOLDER HOOK)

COMMENT

ITEM

- Pro o Good environmental and electrical protection (potted term.)
- Pro o Requires fewer detail parts than concept A
- Pro o Provides very reliable electrical termination
- Pro o Provides max contact area between controller and heat sink
- Con o Does not permit bussing controllers together with bus bars thus increasing wiring on panel assembly, however, they can be jumpered together to reduce the quantity of wire.
- Con o Difficult to replace failed controller: replacement will require: (1) removal of failed controller stub leads from connector and inserting stub leads from new controller into connector, or (2) cutting stub leads from failed controller and splicing in new controller without taking old leads out of connector. Limited space is available for splices. Accumulation of splices during maintenance action will increase wiring congestion on panel.
- Con o Not practical to clock controller installation on base.
- Con o Controller removal will require some harness rework, cutting string-ties to remove stub leads, etc.
- Con o Controller replacement may require removal of entire load center from airplane (in the case of the avionics bay centers, LH and RH, this will require adding a connector solely for this purpose)
- Con o Will not permit trouble-shooting by probing terminals on controller
- Con o Will require potting terminals
- Con o Heat from soldering process could damage the electronics inside controller

CONCEPT C (SCREW-LUG TERMINALS)

<u>COMMENT</u>	<u>ITEM</u>
Pro	o Requires fewer detail parts than concept A
Pro	o Allows controllers to be bussed together with bus bars thus reducing amount of wiring on load center assembly
Pro	o Provides max contact area between controller and heat sink
Pro	o Provides very reliable electrical termination
Pro	o Replacement of controller will not require harness rework (no string ties to cut, no stub leads to remove from harness, etc.)
Pro	o Will permit avionics bay load centers to be built as part of the main harness in the same manner as the A7 circuit breaker panels, that is, without an intermediate connector between the load center assy and the main harness
Pro	o Will permit trouble-shooting by probing terminals on controller
Con	o Bus bars and wiring will interfere with removal of controller because: (1) might have to remove bus bar from several controllers (2) wiring must be carefully installed to prevent interfering with removal of controllers
Con	o Requires a crimp lug on each wire and a screw and washer at each terminal
Con	o Not practical to clock controller installation on base
Con	o Will be difficult to remove/replace terminal nuts and wire lugs in adverse conditions

CONCEPT D (COMMON TERMINATION SYSTEM)

COMMENT

ITEM

- Pro o Provides easy method of replacing controller
- Pro o Provides max contact area between controller and heat sink
- Pro o Provides "environmental" seal as part of termination system
- Pro o Requires fewer detail parts than concept A
- Con o Will not permit bussing controllers together with bus bars thus increasing amount of wire on panel assembly
- Con o Early experience with this type of terminations showed the system to lack high reliability (i.e., additional development/testing required)
- Con o Not possible to clock controller installation on base
- Con o Will not permit trouble shooting by probing terminals
- Con o No convenient way to inspect sockets for contamination prior to mating
- Con o Provides poor electrical termination

CONCEPT E (WIRE WRAP)

COMMENT

ITEM

- Pro o Provides very good electrical termination
- Pro o Requires fewer detail parts than concept A
- Pro o Provides max contact area between controller and heat sink
- Con o Requires use of solid wire for load center assy (In the case of the avionics bay load centers, it will be necessary to add an intermediate connector to change from solid wire to stranded wire for routing through the main harness)
- Con o Does not permit bussing controller together with bus bars thus increasing amount of wire on panel
- Con o Replacement of controller will require some harness rework (cutting string ties, working slack to post, etc.)
- Con o Not possible to clock controller installation on base
- Con o Extra termination length is required for each wire-to-post junction (wire cannot be removed from post and rewrapped without cutting off the end of the wire previously wrapped around the post). This extra length will increase the wiring complexity of the panel.
- Con o Requires special tool to make or remove connection at terminal
- Con o Requires environmental protection by potting or conformed coating

CONCEPT F (PIGTAILS)

COMMENT

ITEM

- Pro o Good environmental and electrical protection
- Pro o Requires fewer detail parts than concept A
- Pro o Provides very reliable electrical termination
- Pro o Provides max contact area between controller and heat sink
- Con o Does not permit bussing controllers together with bus bars thus increasing wiring on panel assy
- Con o Difficult to replace failed controller: replacement will require: (1) removal of failed controller stub leads from connector and inserting stub leads from new controller into connector, or (2) cutting stub leads from failed controller and splicing in new controller without taking old leads out of connector. Limited space is available for splices. Accumulation of splices during maintenance action will increase wiring congestion on panel.
- Con o Not practical to clock controller installation on base.
- Con o Controller removal will require some harness rework, cutting string-ties to remove stub leads, etc.
- Con o Controller replacement may require removal of entire load center from airplane (in the case of the avionics bay centers, LH and RH, this will require adding a connector solely for this purpose)
- Con o Will not permit trouble-shooting by probing terminals on controller

comparable in scores (14, 15 and 17 respectively). The last two concepts (wire wrap and plug-in) faired poorly due mainly to environmental protection difficulties and the resulting reliability impact.

3.2.1 Termination Summary

In conclusion, SSPC termination selection can be divided into the following three categories:

- (a) Single channel SSPC modules should be terminated with screw lug terminals
- (b) Multichannel SSPC modules for external (of EMUX terminal) mounting should be terminated with CTS or pc board connector techniques unless sufficient space exists for screw lug terminals (not likely). This results from the reduced reliability of the multichannel assembly which will necessitate ease of removal for maintenance purposes.
- (c) Multichannel SSPC modules for installation within EMUX terminals should be terminated with plug-in or pc board connector techniques for the same reason discussed for the multichannel controller concept.

3.3 SSPC Installation Weight Factors

The installed weight of a power controller includes, in addition to the SSPC weight, the weight of:

- (a) allocated fraction of enclosure
- (b) allocated fraction of heat sink
- (c) wire harness to EMUX terminal
- (d) allocated channels of EMUX terminal
- (e) allocated weight of redundant processor memory.

Table 9 depicts these contributing weights for SSPC installation in the A-7 aircraft. As shown in the table, most weight contribution is from the enclosure, heat sink and SSPC module. Since most of the SSPC's 38.48 percent weight contribution is imposed by the dedicated SSPC case, significant weight reduction might be possible by removing the case and mounting the internal electronics directly on a common pc board or module assembly with several other SSPCs. The result is a multichannel SSPC which may be constrained by the following potential problems:

- o Impact of single mode failures within multichannel SSPC module
- o Impact on maintainability and logistic costs of replacing an entire multichannel module when only one channel fails
- o Space and weight penalties for less than 100 percent utilization of all installed SSPC channels
- o The feasibility of providing programmable trip levels.

The influence of these potential problem areas should be studied when establishing feasibility and payoff of a multichannel SSPC approach.

Likewise, by integrating the SSPC into the EMUX terminal, the potential advantages outlined in paragraph 3.1.4 above could yield significant weight savings. In Table 10 are tabulated estimated weight projections for various SSPC configurations. These weights are based on gross engineering estimates using the single channel SSPC module installation weight factors of Table 9. As shown in Table 10, potential weight savings for an A-7 complexity aircraft could be as high as 57.2 and 110.4 pounds for multichannel non-integrated and multichannel integrated SSPCs. Using the previously quoted cost/weight sensitivity of 7.83×10^5 \$/Lb, a weapon system life cycle cost saving of 44.8 million to 86.4 million dollars may be achievable. The significant point to be made is that potential cost savings warrant further investigation.

TABLE 9
SSPC INSTALLATION WEIGHT FACTORS
(SINGLE CHANNEL - TWO-WIRE BIT INTERFACE)

ITEM	WEIGHT (LBS)	PERCENT OF TOTAL WEIGHT	SOURCE OF DATA
SSPC	0.156	38.48%	MIL-P-81653/2A
Enclosure and Head Sink	0.123	30.33%	Δ between Figure 27 average weight and SSPC weight
Wire Harness	0.0756	18.64%	Para 6.1.1.1
EMUX Channels	0.0508	12.53%	Para 6.1.1.1
EMUX Memory	0.0000768	0.02%	Note 1
TOTAL	0.4054768	100.00	

Total single channel SSPC installation weight is 0.405 pounds.

Note 1: A 16K x 18 bit core memory weighs 3.7 pounds or 1.28×10^{-5} pounds/bit. Since three bits of data are stored in two core memories (redundant), six bits are required for each SSPC for a weight of 7.68×10^{-5} pounds.

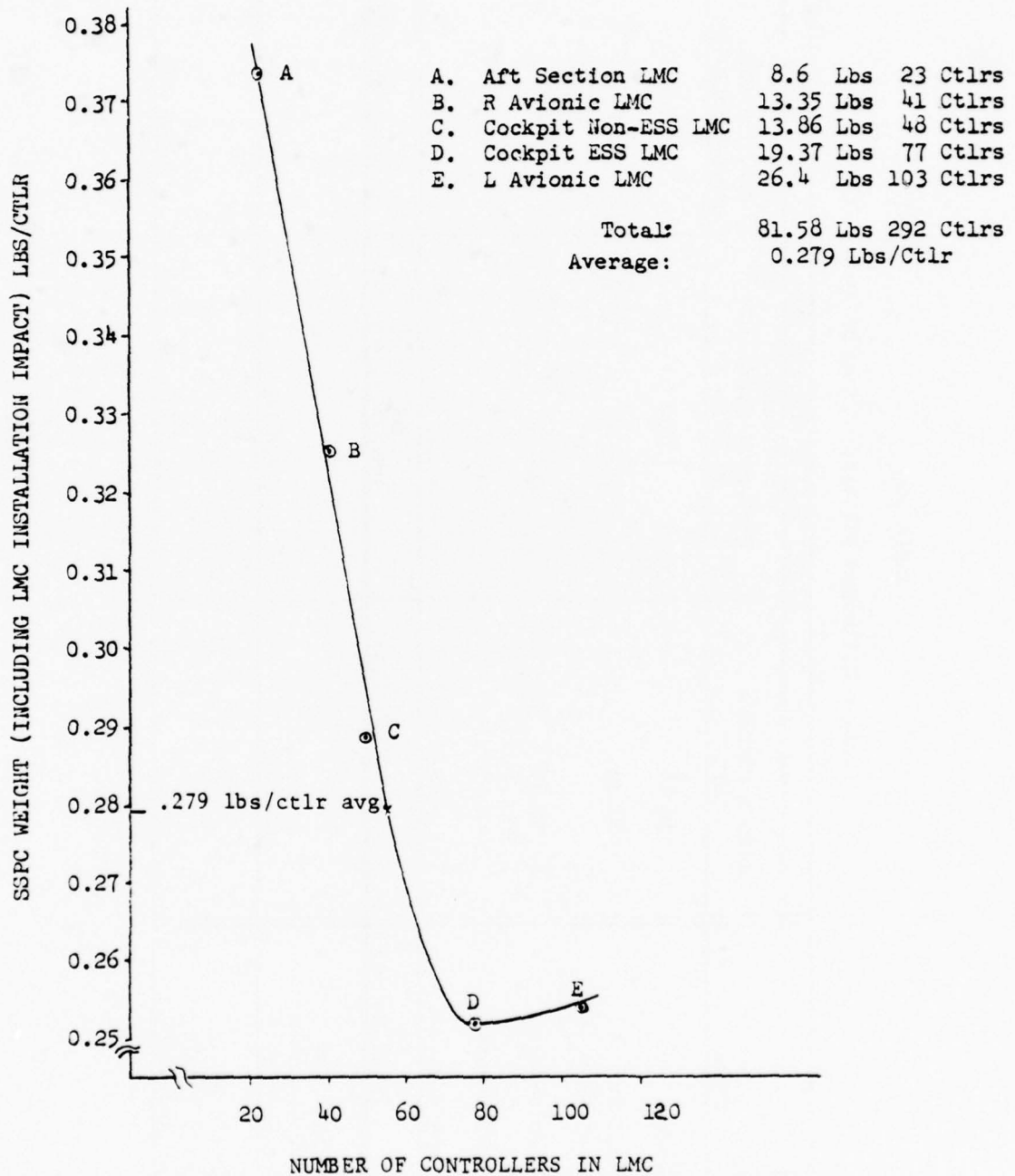

FIGURE 27 SSPC WEIGHT VS LMC CONTROLLER QUANTITY

TABLE 10
WEIGHT ESTIMATES FOR SPPC CONFIGURATIONS

ITEM	WEIGHT PERCENTAGE PER SPPC		
	SINGLE CHANNEL SSPC	MULTICHANNEL SSPC-EXTRATERMINAL MOUNTED	MULTICHANNEL SSPC-INTEGRATED
SSPC	38.48	7.70	7.50
Enclosure & Heat Sink	30.33	25.78	13.04
Wire Harness	18.64	18.64	0.00
EMUX Channels	12.53	12.53	11.28
EMUX Memory	0.02	0.02	0.02
Total % (Lbs.)	100% (0.405 Lbs)	64.67% (0.262 Lbs)	31.84% (0.129 Lbs)
Weight for 400 Channels (A-7 Reqmts)	162 Lbs	104.8 Lbs	51.6 Lbs
Delta Wt From Single Channel SSPC	-	-57.2 Lbs	-110.4 Lbs

3.4 SSPC Reliability/Maintainability Cost Impact

Life cycle cost sensitivity to electrical system MTBF deltas for the A-7 are documented in appendix B of Reference 2. These delta costs were based on an estimated electrical system MTBF (a factor of maintenance rate) of 60 hours.

This 60 hour MTBF is close (60.6 hours actual) for the conventional A-7 aircraft electrical system. An A-7 electrical system implemented with EMUX and SSPCs, however, has a significantly improved MTBF (136.2 hours versus 60.6 hours). This higher system MTBF means that the total aircraft MTBF (approximately 0.9 hours) is influenced less by an EMUX electrical system than by a conventional system. Based on the final variation in total aircraft MTBF, the change in maintenance related life cycle costs over the life of the aircraft varies less than 1 million dollars as the single channel SSPC reliability is changed from 2.0 to 5.0 failures per million hours. More significant cost penalties may accrue as a result of mission effectiveness related costs.

In previous analyses of SSPC reliability, the significant driver on reliability was the ambient temperature. While judicious component selection and derating by the SSPC manufacturer is necessary, control of device junction temperatures will be in the hands of the airframe manufacturer, at least until integration of the SSPC into EMUX terminals occurs. In light of this factor, the SSPC manufacturers should package the controller to permit simple, efficient heat transfer from the power switching transistor to the outside environment.

3.5 SSPC Configuration Trade Summary

In conclusion, SSPC configuration definition can be divided into three options. The first configuration is a single output channel SSPC

module with two wire BIT SSPC/EMUX interface. The SSPC provides terminal lug terminations as illustrated in Figure 26 for Concept C.

The second configuration option consists of a multichannel output SSPC module with either a two wire BIT EMUX interface or a redundant serial digital interface. The module termination should either be pc board pins or CTS with consideration given to screw lug terminals for input power bussing. The modules should incorporate field programmable trip ratings.

The third configuration option consists of a multichannel output SSPC module with a direct digital interface to EMUX terminal circuitry. This module would likely be in a pc board configuration and would be an integral part of the EMUX terminal. Trip levels of each output channel should be field programmable for reduced logistics cost. SSPC power supply and I^2t circuitry can possibly be shared with the parent terminal thereby relegating only the power switch and associated voltage/current sensors to the SSPC plug-in module.

4.0 SSPC SIGNAL INTERFACE CRITERIA

Questions often arise as to the need or validity for the various input/output controls needed for SSPCs. The following paragraphs provide a summary discussion and rationale concerning the various input/output controls and types often requested for SSPCs. Signal controls discussed include the isolated control input, trip output, status output and the lockout input. The two-wire BIT interface is also discussed. Additionally, rationale for the Normally Closed (N.C.) SPPC and the DC power output from an AC source are summarized.

4.1 Input-Output Signal Interface

Following is a summary of the input-output signal control requirements for SSPCs.

(1) Isolated Input Control

The need for isolated input control is determined by the application. If the power controller is used in an electrical system consisting of a single power source, then isolation is not required. This assumes the "control" power source is the same as the "load" power source. Schematically, this is shown in Figure 28. Most aircraft have two power

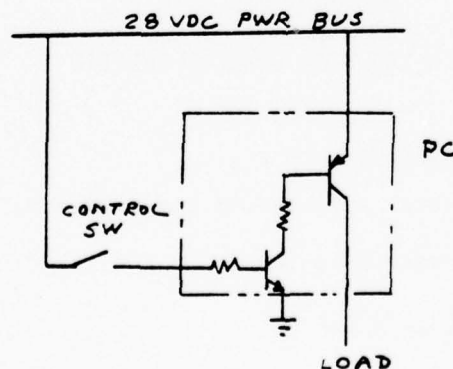

FIGURE 28 SINGLE POWER SOURCE FOR POWER AND CONTROL

sources, i.e., 28VDC and 115VAC. In conventional electrical systems, 28VDC is used for "control" power. Obviously, it is desirable that the 28VDC supply be isolated from the 115VAC supply. In the AAES (Advanced Aircraft Electrical System), the control power will be provided from power supplies contained within "black boxes", i.e., the EMUX multiplex/demultiplex terminals. To prevent EMI problems and possible equipment damage, it is necessary that the power controller control circuit be isolated from the power circuit as shown in Figure 29.

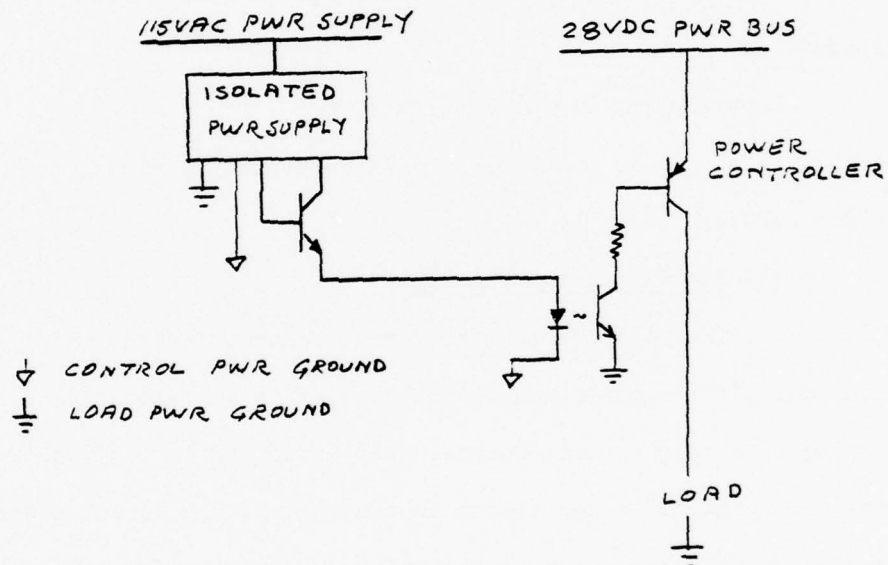

FIGURE 29 ISOLATED SSPC CONTROL CIRCUIT

(2) Isolated Trip Output

The same rationale applies for the isolated trip output as discussed for the isolated control input.

(3) Isolated Status Output

The same rationale applies for the isolated status output as discussed for the isolated control input.

(4) Lockout Input

Lockout input is useful in some applications but this function can be easily generated external to the controller. It is not necessary to include this function within the controller which is a general usage device.

(5) Two-Wire BIT Interface

For system operation, ground support and maintenance reasons, it is desirable to have the following control circuit functions:

- o On/Off control
- o Trip indication
- o Reset capability
- o Controller and power circuit fault indication
- o Control circuit fault indication.

In addition to the above information, it is desirable to minimize the number of wires between the controller and the control electronics (DEMUX terminals). All these requirements are best met with the 2-wire BIT system developed by the Navy.⁵ This system provides ON/OFF control, trip indication, reset capability, control circuit fault indication (circuit opens and shorts) and power controller fault indication all on a common 2-wire circuit. A 10.0 milliampere constant current source is used to accomplish the status indication but this is considered to be a minor requirement from a "black box" design viewpoint. To further reduce the number of wires between the Demux terminal and the controllers, several controllers can often share 2 common return, (e.g., four wires required to control three controllers) depending on the application, installation, the EMI/EMP environment, and the signal/noise margin required for the system control.

4.2 Normally Open/Normally Closed SSPC Option

The basic MIL-P-81653 controllers are normally open (N.O.) devices. To accomplish the normally closed (N.C.) function using N. O. controllers, the control circuit must be connected to input power as shown in Figure 30.

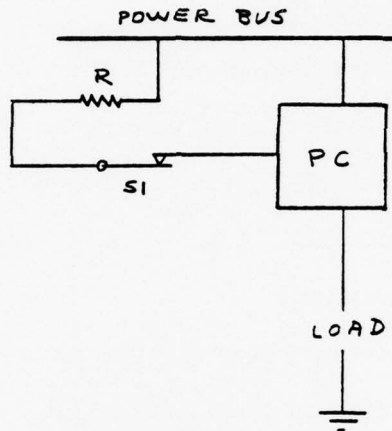

FIGURE 30 N. C. FUNCTION USING N. O. SSPC

This adds complexity to the system since dedicated control wiring must be provided. The N. C. function can be simulated with the EMUX Demux terminal but this function is lost should a Demux failure occur. A N. C. power controller is desirable for two reasons. First, it is desirable to have some loads powered on in the event of a Demux or Emux system failure and, second, it permits simplification and reduction of control wiring necessary to "start-up" the EMUX system.

It is always desirable to have some high priority loads ON independent of the EMUX system. For example, if both processors of a redundant system should become inoperative, it is desirable to have high priority loads such as the communication system operational. At the same time, it is desirable to have the capability to power down these same loads with an

EMUX system for power management purposes. A N.C. power controller will provide this capability where 25, a N.O. device will not. One simple arrangement for accomplishing this feature is shown in Figure 31. The Demux

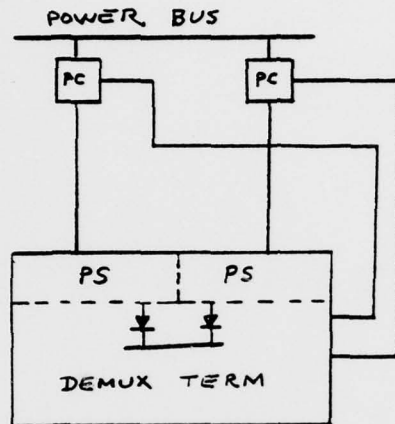

FIGURE 31 TYPICAL REQUIREMENT FOR N. C. SSPC

terminals have redundant power supplies. If a momentary overload or fault on one power circuit causes a controller to trip, a reset command signal can still be provided. Both controllers would have to trip to cause complete loss of the terminal. This arrangement, however, does not allow the removal of the terminal from the power bus, i.e., the terminal cannot power itself down. In most applications, it is desirable that all terminals be powered whenever the power bus is energized. Where power management is a system requirement, i.e., use of the SSPC to isolate the terminal from the power bus, a daisy chain arrangement shown in Figure 32 can be used. Still another arrangement is to have one terminal dedicated as a "master terminal" for controlling the remaining terminals. The master terminal will require a dedicated set of control wiring for the SSPC (control/trip reset) which are supplying power to the master terminal.

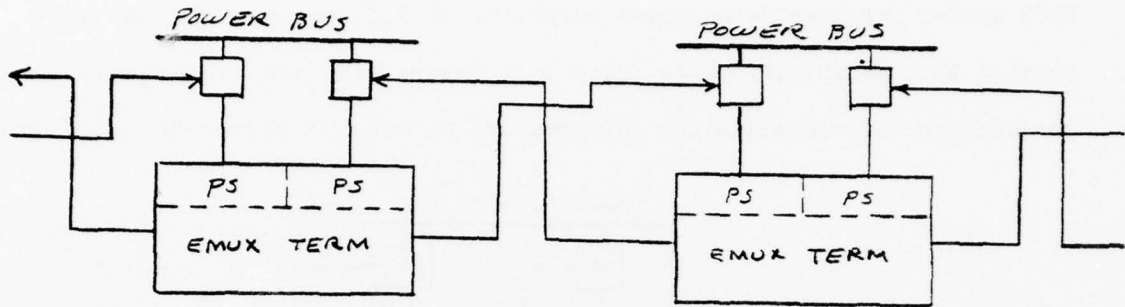

FIGURE 32 EMUX POWER DOWN CAPABILITY USING N.C. SSPC

During system "start-up", the EMUX system can be automatically energized through a N. C. controller whenever the power bus is energized. A tripped N. C. controller can be reset from one or more of the remaining operational Demux terminals.

4.3 DC Power Output SSPC

DC power output from an AC controller has a limited application. Most existing aircraft have AC and DC power sources. DC power requirements are generally about 10% of the AC power requirements and is obtained by converting the AC power to DC power via a static transformer/rectifier (T/R) unit. It should be noted that the standard 28VDC power provided by a T/R unit is electrically isolated from the AC source. This is not true for DC power obtained via an AC controller as shown in Figure 33.

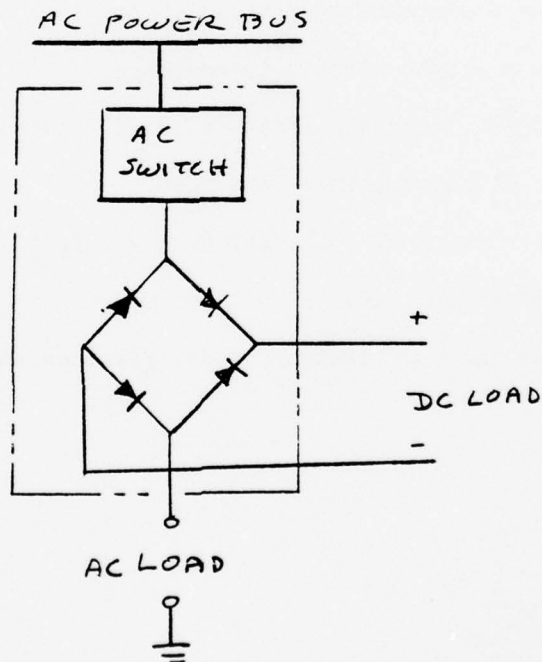

FIGURE 33 AC SSPC PROVIDING DC OUTPUT

The DC load must have a "floating" ground return, i.e., the aircraft structure cannot be used as a return. Also, the DC load will be in series with the AC load unless the two circuits are separated. The ripple content on the DC power limits its usage to very few load types.

4.4 SSPC Control Circuit Recommendations

It is recommended that the control input have the following features:

- o Complete electrical isolation between the control and power circuit. The isolation should consist of 1500 volts minimum with a leakage current not to exceed 1.0 milliampere.
- o Control power requirements should be a minimum and should not exceed 100 milliwatts.
- o The number of control wires should be held to a minimum. The 2-wire BIT concept which provides a multiplicity of data on a single circuit is recommended.
- o It is recommended that the N. C. controller as well as the N. O. controller be provided.
- o The option of providing DC power from an AC controller is not recommended.
- o The lock-out feature is not recommended.

5.0 POWER BUS ANALYSIS

Military Standard Specifications for generators require the generator to deliver a minimum of 300 percent of rated load current into a single phase, two phase, and three phase line-to-line and line-to-neutral short circuits for 5 seconds. In actuality, the generators will deliver over 1200 percent rated load current for several cycles. Tests conducted at Vought on a 25 KVA generator showed fault currents of 524 amperes peak (370 amperes RMS) during the first one-half cycle after the fault was applied. The fault current increased to 629 amperes peak (445A RMS) before the circuit breaker tripped (590 milliseconds after the fault was applied). The test circuit is shown in Figure 34. The test results are shown in Figure 35. Minimal loads were operating from the bus at the time the fault was applied. Tests were not made with varying loads connected to the bus to determine the impact these loads would have on the fault current. However, it is felt these loads will have minimal impact on the fault current during the first half cycle primarily because the loads are transformer (power supply) loads.

5.1 Fault Current Calculation Method

A method for calculating fault currents is presented in ARP 1199 "Aircraft Recommended Practices for the Selection, Application and Inspection of Electric Overcurrent Protective Devices" dated October 1971. This document was prepared by SAE Sub-committee A-2A ARP Task Force. Following is taken from that document:

"Due to the resistance and reactance which is prevalent in all electrical circuits, fault currents are found to be asymmetrical in actual practice. A typical short-circuit current is composed of a symmetrical component and a d.c. transient component. The sum of these two components results in an asymmetrical waveform.

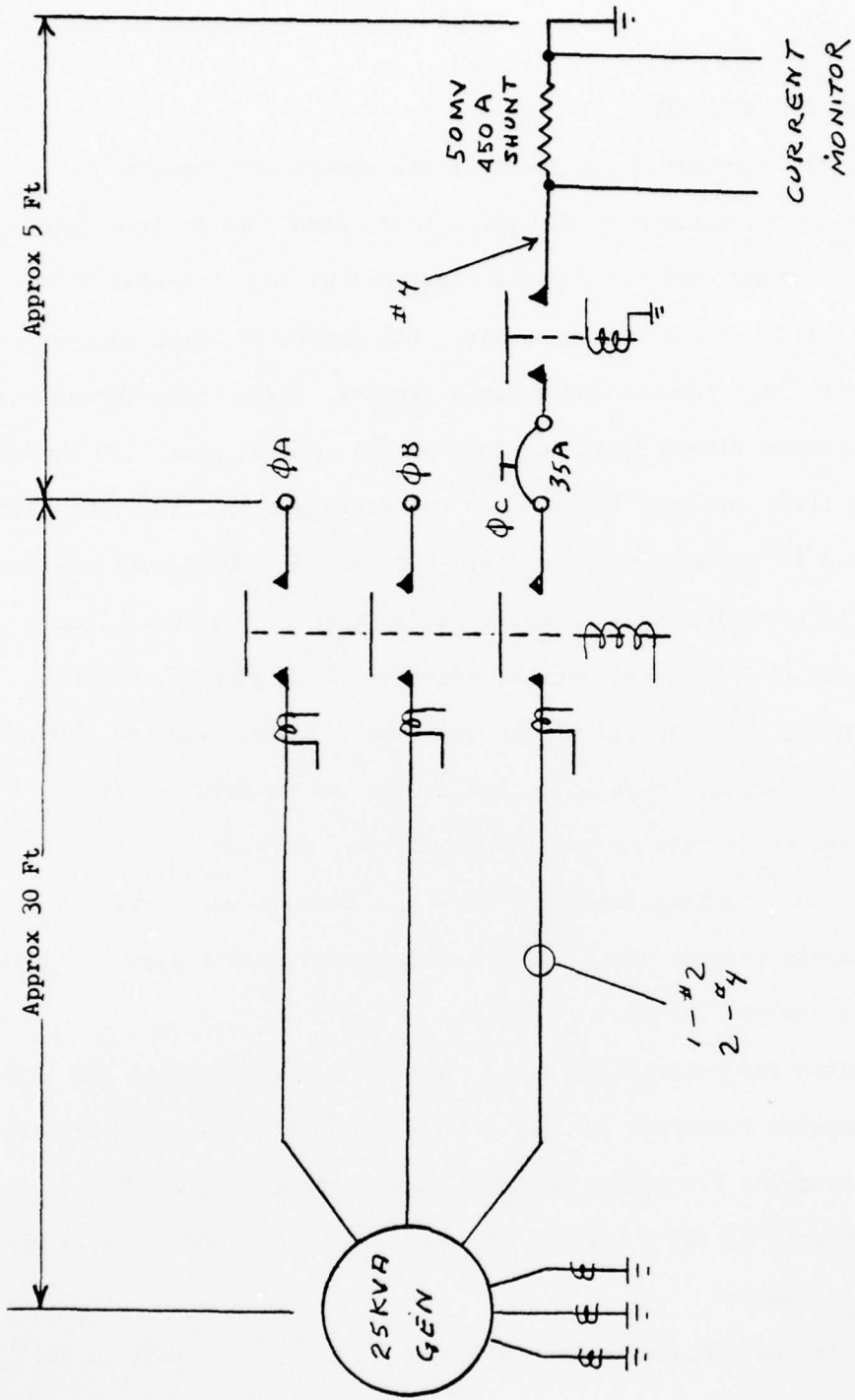

FIGURE 34 FAULT CURRENT TEST CIRCUIT

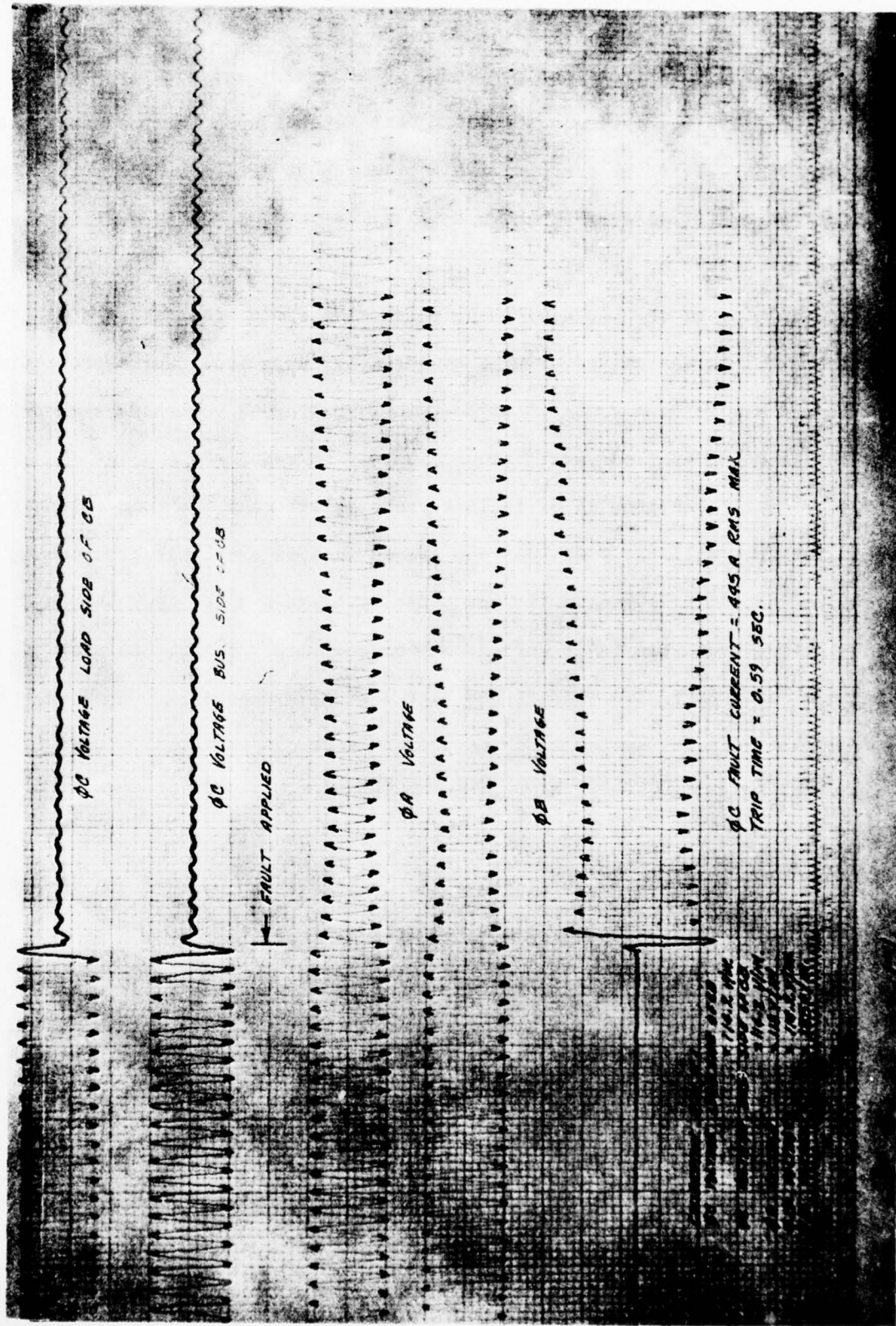

FIGURE 35 APPLICATION OF AC FAULT CURRENT THROUGH A 35 AMPERE CIRCUIT BREAKER (FAULT APPLIED AT THE CIRCUIT BREAKER)

The d.c. transient component is momentary and usually dies out after the first few cycles. This component depends upon the reactance and resistance of the total circuit with a pure reactive circuit providing the maximum asymmetrical current and a totally resistive circuit resulting in no asymmetry (zero d.c. transient component).

In the calculations that follow, the symmetrical short-circuit current will be determined using a conservative approach. Where protective devices are given a momentary (asymmetrical) rating as well as a symmetrical rating, a more detailed fault calculation may be required.

1. The problem of fault current is actually two fold as under no circumstances will the fault current exceed what is available from the vehicle generating systems. If the capacity of this system is known, a figure for maximum available fault current may be computed. First, one must calculate maximum rated current. This is done for a single phase of grounded neutral, wye connected power system (such as presently almost universally used in aircraft) as follows:

$$\begin{aligned} \text{Let } E &= \text{Rated line to neutral voltage (volts)} \\ (\text{VA}) &= \text{Power system capacity in volt-amps.} \\ I_r &= \text{Rated line to neutral current (amps.)} \\ \text{Then, } I_r &= \frac{(\text{VA})}{3E} \text{ amps.} \quad (1) \end{aligned}$$

To determine the fault current, the internal impedance of the generator regulator system must also be known. This is usually expressed in terms of percent of capacity. For most typical 400 hertz generators, this value is seldom less than 8%. (It is recommended that the generator manufacturer be consulted for nameplate impedance.) Then, to compute maximum fault current, I_{fn} , one may consider that:

$$I_{fm} = \frac{I_r}{\frac{8\%}{100}} = \frac{I_r}{0.08} = 12.5 I_r \quad (2)$$

Equation (2) may be substituted in Equation (1) to obtain:

$$I_{fm} = \frac{12.5 VA}{3E} \quad (3)$$

2. Example:

Consider a 60 KVA, 115/200 volt 400 cycle system. What is the approximate value of I_{fm} ?

$$\text{From equation (3), } I_{fm} = \frac{(12.5) (60,000)}{(3) (115)} = 2170 \text{ amperes} \quad (4)$$

This states that 2170 amperes is the maximum current which can be made to flow with a bolted fault at the generator terminals.

3. Once I_{fm} has been determined, the fault current on a load feeder line may be considered.

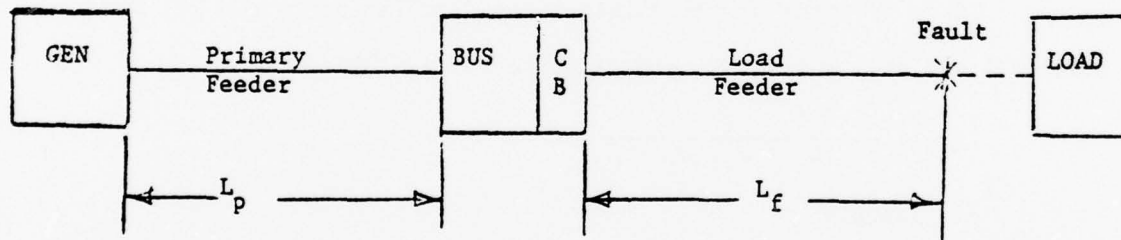

R_p = Resistance of primary feeder L_p feet long from generator to bus.

R_f = Resistance of load feeder L_f feet long from circuit breaker to fault location.

R_{cb} = Equivalent resistance of circuit breaker based on millivolt drop at rated load.

I_f = Fault current (amps.).

$$\text{Then, } I_f = \frac{E}{R_p + R_f + R_{cb}} \text{ amps.} \quad (5)$$

We must next determine means for computing R_p , R_f and R_{cb} as follows:

$$R_p = r_{wp} L_p \quad (6)$$

Where r_{wp} is the resistance in ohms per foot of the primary feeder wire.

Table 11 lists these values for various wire sizes used in aircraft.

$$\text{Also, } R_f = r_{wf} L_f \quad (7)$$

Where r_{wf} is the ohms per foot resistance of the load feeder wire from Table 11.

R_{cb} depends upon the circuit breaker rating.

$$R_{cb} = \frac{V}{I_r} \quad (8)$$

Where V is the typical voltage drop for the particular breaker rating and I_r is the rated current. Table 12 gives values for V for a typical thermally excited aircraft circuit breaker, MS 22073.

Then, in terms of the values taken from Tables 11 and 12, Equation (6) and (7) may be substituted into Equation (5) as follows:

$$I_f = \frac{E}{r_{wp} L_p + r_{wf} L_f + R_{cb}} \quad (9)$$

4. Example

Consider a 60 KVA, 3 ϕ , 115/200 volt, 400 Hz electric power system using a 20 foot #2 Awg. (180 amps) primary feeder. What fault current can be obtained at a location 7 feet from a 5-amp circuit breaker protecting a #18 Awg conductor?

Solution:

A. Compute maximum available fault current (I_{fm}).

From Equation (3),

$$I_{fm} = \frac{(12.5) (60,000)}{(3) (115)} = 2170 \text{ amps.}$$

B. Compute current available at the fault (I_f).

From Equation (9),

$$I_f = \frac{E}{r_{wp} L_p + r_{wf} L_f + R_{cb}}$$

From Table I,

$$r_{wp} = 0.16 \times 10^{-3} \text{ ohms/foot for \#2 Awg., and,}$$

as $L_p = 20$ feet, then,

$$r_{wp} L_p = (20) (.16) (10^{-3}) = 3.2 \times 10^{-3} \text{ ohms.}$$

Likewise, from Table 11

$$r_{wf} = 6.6 \times 10^{-3} \text{ ohms/foot for \#18 Awg., and,}$$

as $L_f = 7$ feet

$$r_{wf} L_f = (6.6) (7) (10^{-3}) = 46.2 \times 10^{-3} \text{ ohms.}$$

Finally, from Table 12, for a 5-amp. circuit breaker,

$$R_{cb} = .05 = 50 \times 10^{-3} \text{ ohms}$$

These values may now be substituted into Equation (9) (remembering that $E = 115$ volts) as follows:

$$I_f = \frac{115}{(3.2 + 46.2 + 50) \times 10^{-3}}$$

or $I_f = \frac{115,000}{99.4}$

or $I_f = \underline{1160 \text{ Amps}}$

as I_f is less than I_{fm} , the fault current will be equal to I_f .

5. The above procedures and examples will result in good conservative values of I_f . As the 400 Hz reactance of all wiring is neglected, the computed values of I_f will be slightly higher than what will occur in practice."

TABLE 11

WIRE RESISTANCE

ASW WIRE SIZE	RESISTANCE MILLIOHMS/FT.
26	42.4
24	26.6
22	16.8
20	10.5
18	6.6
16	4.2
14	2.6
12	1.6
10	1.03
8	0.65
6	0.41
4	0.26
2	0.16
1/0	0.13
2/0	0.08
4/0	0.05

TABLE 12 (MS 22073)

CIRCUIT BREAKER MAXIMUM
VOLTAGE DROP

RATING I_r	VOLT DROP V
1	1.100
2	.700
3	.330
4	.300
5	.250
7.5	.200
10	.150
15	0.100
20	0.100
25	0.100

5.2 SSPC/Power Bus Interface Recommendations

It is difficult to characterize the aircraft AC bus because of varying generator ratings, generator manufacturers, feeder lengths and sizes and equipment connected to that bus. In any event, the power controller should be designed to operate from an "infinitely stiff" bus, i.e., no limitations should be imposed on fault currents. This should be done so as not to restrict the power controller to a specific application. For example, the F-14 has two 90 KVA generators, it is reasonable to expect fault currents of 2600 amperes from a single generator. If the generators are operating in parallel (as was the case with the B1 system), much higher fault currents can be expected.

It should be noted that the VSCF (Variable Speed Constant Frequency) system, currently being used on the F-18, has the capability to "current limit" the fault current to a much lower value. The military standard specification allows current limiting to take place above 300 percent rated current.

The ideal power controller should employ current limiting which will make the device compatible with any power source (bus) rating. The current limiting can be either an "Inverse Time/Current" type or "300 percent rated current" type. Each type has advantages and disadvantages. Vought prefers the 300 percent rated current type because less transients are generated, it is compatible with all aircraft loads, and it provides excellent wire protection. The Inverse Time/Current device may be less expensive to produce but may not be compatible with incandescent type loads (nuisance trips) unless the controller current rating is higher than the load rating which may dictate a next larger wire size.

6.0 SSPC SAFETY CONSIDERATIONS

Man is very sensitive to electric shock. Even though minute shocks can be considered objectionable rather than harmful, they must be taken seriously since harm can be caused from man's reaction to the shock.

It is generally accepted that the threshold of perception is 1.0 milliampere at 60 Hz commercial power. The accepted maximum harmless current is 5.0 milliamperes. The maximum current at which a person is still capable of releasing a conductor is called "let-go" current and is typically between 10 and 20 milliamperes. Currents only slightly in excess of the "let-go" value will cause a person to "freeze" to the conductor. Such currents are painful, frightening, hard to endure and are considered dangerous. The effects of 60 Hertz current on the average adult male is given in Figure 36. These values can be increased approximately 20 percent for a 400 Hertz aircraft power system.

6.1 SSPC Safety Implications

From a power controller design standpoint, the 1.0 milliampere (threshold of perception) should be considered as the maximum value since harm can result from man's reaction to the perception, i.e., bruised knuckles, elbows, etc., when working on the airplane.

A solid state power controller will exhibit a leakage current whose magnitude is a function of temperature, applied voltage and power controller current rating. Specification MIL-P-81653 presently allows 2.0 milliamperes for AC controllers rated through 10.0 amperes, 500 microamperes for DC controllers rated through 5.0 amperes and 1.0 milliampere for a 10 ampere DC controller. The 2.0 milliampere for AC controllers allow the use of SCRs for the power switch. This can be reduced to 1.0 milliampere if high quality power transistors are used for the power switch.

AD-A063 405

TELEPHONICS CORP HUNTINGTON N Y
ADVANCED SOLID STATE POWER CONTROLLER DEVELOPMENT. PHASE I. STU--ETC(U)
SEP 78 R J EDWARDS

F33615-77-C-2017

F/G 10/2

NL

UNCLASSIFIED

AFAPL-TR-78-55

5 OF 5

AD A063405



END

DATE
FILMED

3-79

DDC

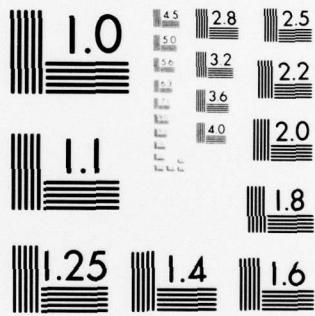

MICROCOPY RESOLUTION TEST CHART
NATIONAL BUREAU OF STANDARDS-1963-A

Circuit design techniques can be employed to reduce output voltage and leakage current to the load terminal as shown in Figure 37.

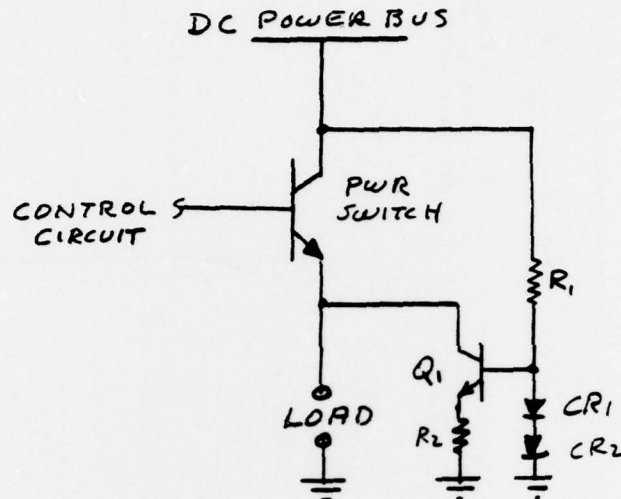

FIGURE 37 LOW LEAKAGE DC SSPC

Basically, a clamp circuit consisting of transistor Q_1 , resistors R_1 , R_2 and diodes CR_1 , CR_2 is used to clamp the output to ground when the power switch is off. The current limiting action of the clamp circuit is set for the maximum leakage current of the power switch. This will prevent the clamp transistor Q_1 from over dissipation when the power switch is on. A more sophisticated approach can be employed which would turn the clamp circuit off when the power switch is on and vice versa.

For an AC switch (power controller), a similar approach can be used as shown in Figure 38. Power dissipation in Q_1 and Q_2 will be typically 50 milliwatts for a 5.0 ampere controller if power transistors ($500 \mu\text{a}$ max leakage) are used for the power switch. The dissipation would increase to 200 milliwatts if SCRs are used for the power switch.

The presence of leakage current has caused some problems in the area of pyrotechnic maintenance and loading philosophy. Maintenance and

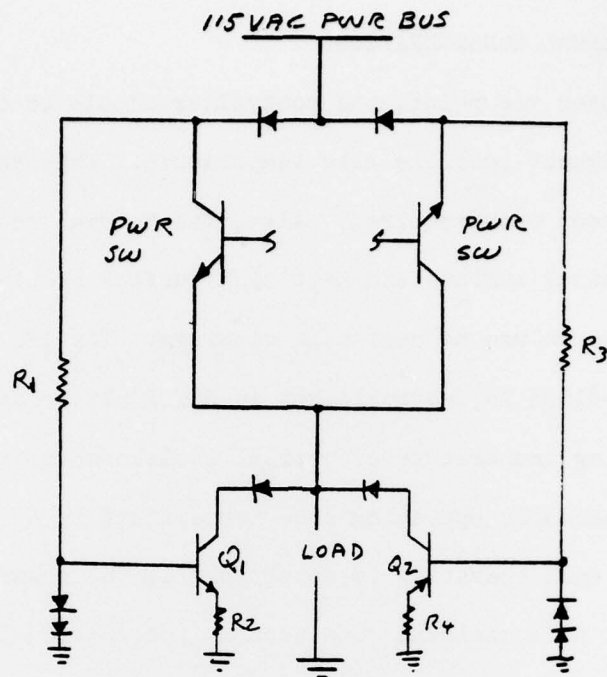

FIGURE 38 LOW LEAKAGE AC SSPC

armament personnel have been reluctant to connect armament hardware to terminals having a presence of voltage. Generally, high impedance type meters are used to monitor the terminal which will show the presence of 28 and 115 volts even though the voltage source is from a high impedance device such as a power controller. The leakage current is not a hazard problem since most electro explosive devices are 1.0 ampere, 1.0 watt devices and will not fire below 1.0 amperes. From a logistics viewpoint, the output voltage should be clamped below 1.0 volt. It is noted that several existing EED Maintenance Test Specifications require the load voltage to be below 50 mv.

6.2 SSPC Leakage Current Recommendation

The maximum leakage current of the SSPC should not exceed 1.0 milliampere. Ideally, clamp circuits or equivalent should be used to clamp the output terminal voltage below 1.0 volt (50 mv if compliance with existing test specifications is desired).

7.0 SSPC THERMAL CONSIDERATIONS

From a user viewpoint, the controller should be capable of operating at the highest possible case temperature. This ensures the minimum volume of heat sink required. Also, the thermal resistance between the controller mounting surface and heat sink surface should be a minimum to further minimize the volume of heat sink required. The 120°C case temperature specified in MIL-P-81653 is desirable but is difficult to attain in view of the limited operating temperature of optical isolators (typically -54°C to 100°C). A more reasonable operating case temperature is 80°C and 100°C for storage. The 80°C case operating is acceptable if the power controller dissipation is held to a minimum. The bottom line, obviously, is to minimize the volume of heat sink thereby minimizing the added weight and volume to the aircraft.

Temperature design requirements for equipment to be used in aircraft are defined in MIL-E-5400 as follows:

<u>Class</u>	<u>Temperature Range @ Sea Level</u>
1	-54°C to 55°C
2	-54°C to 71°C
3	-54°C to 95°C
4	-54°C to 125°C

A controller designed to operate at a case temperature of 120°C (MIL-P-81653) will meet the class 3 temperature requirements. The amount of heat sink required is determined by the case operating temperature, the ambient temperature and the controller power dissipation. Obviously, the controller with the highest case operating temperature and lowest power dissipation will require the least amount of heat sink. The enclosure (case)

for MIL-P-81653 AC controllers rated through 10.0 amperes (1.8 in³) has a thermal impedance from the case to ambient of approximately 2.0° C/W. The 5.0 ampere controller has a dissipation of 8.5 watts which means the controller can operate in an ambient temperature of approximately 100° C with no additional heat sink required.

The thermal resistance between the controller mounting surface and the heat sink should be as low as possible. How best to define the requirement has been the subject of several SAE-A2K meetings. From a user viewpoint, the requirements specified in MIL-P-81653 are acceptable.

7.1 Thermal Trip

Power controllers are protective devices with reset capability. Therefore, it is possible to continually reset the device into an overload. To prevent possible damage to the controller, a temperature sensing circuit should be included within the controller. The over temperature trip limit should be set at a temperature above the rated case temperature and below the maximum junction temperature rating of the power switch (SCR or power transistor) or other internal components which may have a temperature rating.

8.0 SUMMARY

Data and information provided in this report is in response to and in accordance with specific data items required by Telephonics Statement of Work 459A604, Phase I of the Advanced Solid State Power Controller Development program. The report documents typical design data and requirements for EMUX and SSPC installations for fighter-attack aircraft based on the A-7D systems. The report provides a summary of design requirements as reflected by aircraft loads for start-up and continuous operation. The report provides trade data and information concerning the SSPC configuration, termination techniques and requirements, thermal design factors, safety considerations, and cost implications of the SSPC as related to military aircraft applications.

9.0 BIBLIOGRAPHY

1. Perkins, J. R., Marek, A. J., Turnage, W. T., "Power Controller Breadboard and Development Requirements", Report 2-57110/4R-3195, Vought Corporation, March 1975.
2. Uhlhorn, R. W., et al, "A-7 ALOFT Economic Analysis", Final Report on Contract N00123-76-C-0324, McDonnell Aircraft Company, November 1976.
3. Perkins, J. R., et al, "Advanced Aircraft Electrical System (AAES) A-7E Prototype Design", Final Report No. NADC 76193-30, Vought Corporation, August 1977.
4. Isham, Robert, et al, "DC Power Controller with BIT", RCA Corporation, dated 8 August 1975. Contract Number N62269-72-C-0642.
5. Perkins, J. R., Heinzman, H. W., and Turnage, W. T., "Update of the Data Handling System, Studies and Consultation", Report No. 2-57110/3R-3083, Vought Corporation, April 1973.
6. Air Force Systems Command Design Handbook, AFSC DH1-6 DN4E1 dated 20 Jilly 1969, Chapter 4, Section 4E, Aerospace Ground and Ancillary Equipment.