

AD-A064 124

TECHNICAL
LIBRARY

AD A-064124

AD-E400 242

TECHNICAL REPORT ARLCD-TR-78032

FLUIDIZED BED INCINERATOR FOR DISPOSAL
OF PROPELLANTS AND EXPLOSIVES

ROBERT SCOLA, P.E.
JOSEPH SANTOS

OCTOBER 1978



US ARMY ARMAMENT RESEARCH AND DEVELOPMENT COMMAND
LARGE CALIBER
WEAPON SYSTEMS LABORATORY
DOVER, NEW JERSEY

APPROVED FOR PUBLIC RELEASE; DISTRIBUTION UNLIMITED.

The views, opinions, and/or findings contained in this report are those of the author(s) and should not be construed as an official Department of the Army position, policy or decision, unless so designated by other documentation.

Destroy this report when no longer needed. Do not return to the originator.

The citation in this report of the names of commercial firms or commercially available products or services does not constitute official endorsement or approval of such commercial firms, products, or services by the United States Government.

UNCLASSIFIED

SECURITY CLASSIFICATION OF THIS PAGE (When Data Entered)

REPORT DOCUMENTATION PAGE		READ INSTRUCTIONS BEFORE COMPLETING FORM
1. REPORT NUMBER ARLCD-TR-78032	2. GOVT ACCESSION NO.	3. RECIPIENT'S CATALOG NUMBER
4. TITLE (and Subtitle) FLUIDIZED BED INCINERATOR FOR DISPOSAL OF PROPELLANTS AND EXPLOSIVES		5. TYPE OF REPORT & PERIOD COVERED
		6. PERFORMING ORG. REPORT NUMBER
7. AUTHOR(s) Robert Scola, P.E. Joseph S. Santos		8. CONTRACT OR GRANT NUMBER(s)
		10. PROGRAM ELEMENT, PROJECT, TASK AREA & WORK UNIT NUMBERS
9. PERFORMING ORGANIZATION NAME AND ADDRESS Commander, ARRADCOM MTD, (DRDAR-LCM-S) Dover, NJ 07801		12. REPORT DATE October 1978
11. CONTROLLING OFFICE NAME AND ADDRESS Commander, ARRADCOM STINFO (DRDAR-TSS) Dover, NJ 07801		13. NUMBER OF PAGES 128
		15. SECURITY CLASS. (of this report) Unclassified
14. MONITORING AGENCY NAME & ADDRESS (if different from Controlling Office)		15a. DECLASSIFICATION/DOWNGRADING SCHEDULE
16. DISTRIBUTION STATEMENT (of this Report) Approved for public release; distribution unlimited.		
17. DISTRIBUTION STATEMENT (of the abstract entered in Block 20, if different from Report)		
18. SUPPLEMENTARY NOTES		
19. KEY WORDS (Continue on reverse side if necessary and identify by block number)		
Incineration	Explosive grinding	Bubble formation
Fluidized bed	Hazards evaluation	Slurry pumping
Pollution abatement	Operating criteria	Economic analysis
Rotary Kiln	Instrumentation	Emissions data
Wet air oxidation	Fluidization	
20. ABSTRACT (Continue on reverse side if necessary and identify by block number)		
<p>The disposal of waste propellants and explosives (P&E) has come under the close scrutiny of the Environmental Protection Agency (EPA) since the ban on open burning. In order to conform to current and anticipated regulations, the fluidized bed incineration technique was developed and evaluated as a potential solution to this disposal problem. This incineration technique was chosen due to its reported characteristics of high combustion efficiency, low emissions, high heat sink capacity, low operating cost, and inherent safety features.</p>		

(cont)

UNCLASSIFIED

UNCLASSIFIED

SECURITY CLASSIFICATION OF THIS PAGE(When Data Entered)

The evaluation proves that the fluidized bed incinerator promises to be well suited for the destruction of waste P&E because it can safely destroy the P&E wastes and conform to current and anticipated standards for NO_x , HC, and CO without the use of abatement equipment.

Various support equipment were evaluated such as pneumatic mixing and control instrumentation, slurry pumping and monitoring apparatus, cooling tower, and exhaust gas analyzer.

Testing was completed to obtain optimum operating parameters for each material (TNT & Comp B). In addition, detonation propagation tests were conducted on a wide variety of typical wastes to ascertain safe concentrations and feed rates. These tests included both static and dynamic phases to simulate all possible operational modes.

UNCLASSIFIED

SECURITY CLASSIFICATION OF THIS PAGE(When Data Entered)

FOREWORD

The work described in this report was conducted at the U.S. Army Armament Research and Development Command (ARRADCOM), Dover, NJ by the Special Technology Branch, Manufacturing Technology Division, Large Caliber Weapon Systems Laboratory, as part of AMC Project 54114. The objective was to evaluate the disposal of waste propellants and explosives by fluidized bed incineration.

TABLE OF CONTENTS

	<u>Page no.</u>
Background	1
Alternate Solutions	2
Development of the Fluidized Bed Incinerator	3
Pilot Plant Design and Testing	3
Prototype Design	5
Operating Criteria	5
Equipment	17
Slurry Preparation and Feed System	17
Economic Analysis	26
Discussion of Results	37
Conclusions	43
Recommendations	45
References	45
Appendixes	
A Alternate Solutions	47
B Equipment	57
C Hazards Evaluation	69
D Low Cost System Design	73
E Catalyst and Alternate Fuel Study	77
F Evaluation Run Data	111
Distribution List	115

<u>No.</u>		<u>Page no.</u>
8	Incinerator instrumentation and control panel	21
9	Curve of slurry flow rate and velocity vs header pressure	23
10	Slurry injection and monitoring system	24
11	Curve of slurry density vs weight percent slurry	25
12	Control panel for monitoring slurry flow and injection	27
13	Typical "slurry flow monitor" recorder trace (flow: 3.5 gal/min of slurry)	28
14	Economic analysis factors	29
15	Comparison of operating costs (250 lb/hr)	32
16	Comparison of operating costs (1000 lb/hr)	33
17	Factors for PVUC economic analysis (AR 37-13)	36
18	Typical recorder trace of FBI grid and bed temperatures during test run	39

SUMMARY

The disposal of waste propellants and explosives (P&E) has come under the close scrutiny of the Environmental Protection Agency (EPA) since the ban on open burning. In order to conform to current and anticipated regulations, the fluidized bed incineration technique was developed and evaluated as a potential solution to this disposal problem. This incineration technique was chosen due to its reported characteristics of high combustion efficiency, low emissions, high heat sink capacity, low operating cost, and inherent safety features.

The evaluation proves that the fluidized bed incinerator promises to be well suited for the destruction of waste P&E. It is a compact disposal system that can safely destroy the P&E wastes and, through the use of a catalyst, conform to current and anticipated standards for NO_x , HC and CO without the use of abatement equipment.

Detonation propagation tests were conducted on a wide variety of typical wastes to ascertain the safe concentrations and feed rates. These tests included both static and dynamic phases to simulate all possible operational modes.

The test and evaluation phase of the prototype system verified the design concepts demonstrated by the pilot plant program. The successful completion of several test runs at the 22% (by wt) slurry concentration level displayed the capability of the fluidized bed incinerator to comply with the 200 ppm goal for NO_x and other gaseous emissions. These results proved that the fluidized bed incinerator is a safe, efficient, economical system for the disposal of P&E wastes with minimal pollution. Therefore, this system should be considered for installation at facilities where air pollution is a major constraint on incinerator design.

BACKGROUND

In the manufacture, loading, assembly, and packing of munition items, there are various non-usable wastes generated which must be disposed of in a sound ecological manner. This disposal has come under close scrutiny due to the EPA's (state and federal) regulations and the recent ban on open burning. The operation of these disposal facilities must be in accordance with both local and federal regulations. These regulations vary from one area to another according to the local air quality which depends on: a) geographic location, b) meteorological conditions, c) industrial proximity, d) pollution type, and e) size of community. An example of air quality regulations varying with geographic location is when certain midcentral United States areas have high, non-urban, particulate concentrations of over 40 micrograms/cubic meter, the northcentral portion of the United States may have particulate concentrations of less than 10 micrograms/cubic meter. These boundary air quality standards are derived from the level of pollution emissions as well as background concentrations due to the proximity of industrial air pollution contributors, vehicle density, residential heating, and natural releases (swamp, mines).

The current practice of disposing of waste propellants and explosives (P&E) by open burning is characterized by the stockpiling of hazardous materials, air and water pollution, personnel exposure, and inefficient combustion. In order to eliminate these problems, and provide a reliable safe method of disposal, it was decided that incineration technology offered the best solutions to the problem. Therefore, the P&E incinerator development project was initiated.

The efficiency of incinerators is dependent on the time the waste is inclosed in the combustion chamber. The volume of the chamber should be large enough to contain the gas flow long enough for the complete combustion of the solid waste and gaseous products. Usually the most important factor in combustion is the temperature. Heat is used as the driving force to sustain combustion. In many cases, it is desirable to have auxiliary fuel available to: a) heat up the furnace, b) promote primary combustion when the waste does not contain adequate BTU content for good combustion, c) provide secondary combustion for odor and smoke control, and d) make available supplemental heat for heat recovery units. An additional factor in combustion is turbulence, provided by either baffles, constrictions or process design. Changes in direction and velocity thoroughly mix the products of combustion with the air (oxygen) necessary to complete the combustion process. Separation of the combustion gases would occur if turbulence were not included in the design, and under these conditions some of the gases would leave the chamber unburned. This would necessitate the use of an auxiliary burner, which would decrease process efficiency.

Provision for air for the complete combustion of waste products is mandated. One way air is added to the incinerator is by natural draft through a chimney or stack. The higher the stack, the greater the amount of air that can be brought into the incinerator. Air is also supplied by fans that either blow air into the incinerator (forced draft) or pull air through the incinerator (induced draft). The fan is usually located between the incinerator and stack in induced draft systems. In this case, the hot gases must be cooled to protect the fan. Excess air is usually added to the incinerator to insure complete combustion and regulate incinerator temperature. The excess air requirements differ for various types of waste, which have different compositions and BTU values.

The process of incineration can be described as a controlled, safe, efficient combustion process for burning wastes to an inert residue. When wastes are exposed to a turbulent atmosphere for a critical time period at an elevated temperature, combustion occurs. During combustion, heat is generated, moisture is evaporated, and the combustible portion of the waste is oxidized. Carbon dioxide, water vapor, ash, and non-combustibles are the end products, in addition to the heat generated.

ALTERNATE SOLUTIONS

The incinerator systems (vertical induced draft, rotary kiln (RK), SITPA I & II (simplified incineration technique for pollution abatement), wet air oxidation (WAO), and fluidized bed (FBI)) are all designed to handle the problem of waste P&E disposal. Each attacks the problem in a different manner. Different incinerators can be selected depending on the various emission regulations for the specific site. The more sophisticated P&E incinerators (RK, WAO, FBI) have been designed to meet air pollution standards (existing or forecasted) and provide adequate air and turbulence for proper combustion. Emission control equipment is included on some of these incinerators to further reduce the amount of CO, HC, and NO_x released. Because of the quantity of NO_x emissions, state and federal environmental agencies are identifying, assessing, and promoting the development of cost-effective, commercially viable methods for NO_x control from both existing and new stationary combustion sources. It is anticipated that controls will be required on all P&E waste incinerators and will take the form of lowering NO_x formation during combustion, post-combustion removal of NO_x from the combustion products, or catalytic interaction within the process itself.

In addition, the majority of the incinerator systems require waste particle sizes of approximately 1/8 in. (0.0032 m) to obtain good combustion either in the dry state or for injection as an aqueous slurry. The P&E wastes are in the form of riser scrap, shell washout, process by-products, and unacceptable end items. A large portion of this waste must be reduced in size prior to disposal. The current methods of reducing these wastes are by rotary knife grinders, cone crushers, attrition mills, and ball mills. All of these methods use a water medium of approximately 10 lbs (4.54 kg) of water for each lb (.45 kg) of P&E waste in order to cool the grinding area, prevent the P&E waste from heating up, and help reduce the possibility of spark formation. Water also helps make plastic-type propellant more rigid and, therefore, easier to grind.

Upon reviewing the advantages and disadvantages of the various systems (Appendix A), it was decided that the fluidized bed incinerator was the only system that promised to be able to conform to current and anticipated regulations for P&E incinerators. Its characteristics of high combustion efficiency, low gaseous and particulate emissions, high heat sink capacity, low operating cost, and inherent safety features were the basis for selection of the fluidized bed for further development.

DEVELOPMENT OF THE FLUIDIZED BED INCINERATOR

Pilot Plant Design and Testing

ARRADCOM, in addition to having the responsibility for the overall control of the P&E incinerator project, was obligated to select and develop an improved incineration system for future use. A study was performed, and it was concluded that the fluidized bed incinerator was the best system to meet the future needs of the Army. The current design of the fluidized bed incinerator pilot plant evolved from a small pilot plant evaluation performed under a contractor support effort by Exxon Research and Engineering Company (ref. 1). The system selected for investigative studies (fig. 1) was six in. (0.15 m) in diameter and 9 ft (2.74 m) high and had a dry explosives feed rate of 7 lbs/hr (3.18 kg/hr). This fluidized bed incinerator was designed to accept a solid/water slurry feed. The bed was sized so it could be fluidized with approximately 50% of the anticipated requirement of 120% of stoichiometric air. The importance of this fact is that it improved the flexibility of the incinerator to allow the operation of the system in either a one or two stage combustion mode, i.e., all the air is fed into the bottom of the bed or part of the air is fed into the bottom and part is fed into the upper portion of the bed.

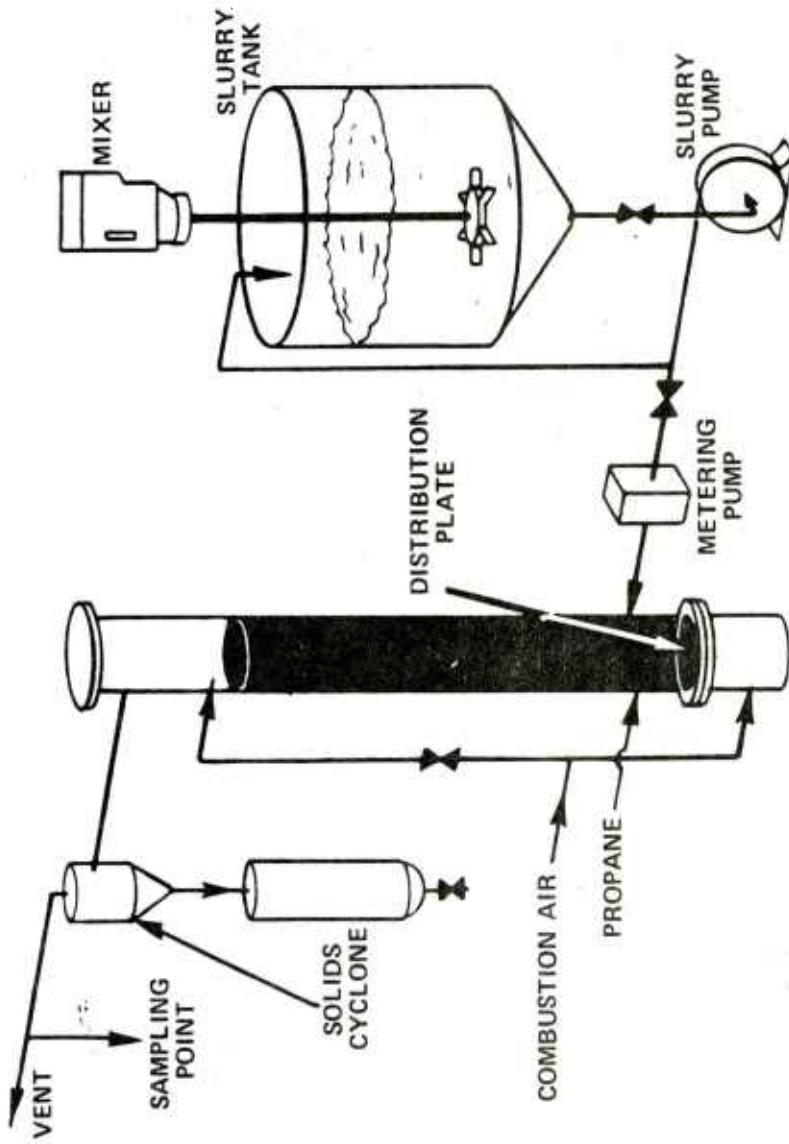

Figure 1. Lab-scale fluidized bed combustor.

In addition to the incinerator, the system includes a slurry feed system, cyclone particulate collector, and stack gas analyzer. The slurry feed system has a mix/feed tank with a large recirculating line. The incinerator feed is tapped from this line and fed into the incinerator through a metering pump. The cyclone collector removes any particulates from the exhaust gas before the gas is analyzed for NO, NO_x, CO, CO₂, HC, and O₂.

A series of 37 test runs were made in which the bed temperature, air velocity, feed rate, and types of waste materials were varied (table 1). Runs were made in both the one-stage and two-stage modes for durations of up to 6 hours.

The incinerator operated effectively in disposing of the explosives and propellants, however, the emission levels of 840 ppm - NO_x, 650 ppm - CO and 350 ppm - HC, were well above the 200 ppm goal for each of these pollutants and were approximately equal to the untreated emissions from the rotary kiln and vertical incinerators. At this point in the test program, it was decided to try a catalyst in the bed. After some preliminary testing, nickel oxide was selected for use in the fluidized bed. An addition of 6% (by wt) of nickel oxide to the alumina bed (Al₂O₃) caused a spectacular reduction in the emissions from the incinerator, 57 ppm - NO_x, 40 ppm - CO, 10 ppm - HC (table 2).

The results of this program led to the decision to convert the ARRADCOM vertical incinerator to a fluidized bed incinerator (figs. 2 and 3). Some of the major components designed were the preheater, plenum, injection nozzles, air distribution grid, and blower.

Prototype Design

The schematic diagram used to determine design operating conditions is shown in figure 4. Various parameters were determined for air, fuel, and explosive slurry entry stations to the final discharge from the combustion chamber which leads into the cyclone separator used to remove any residual particulates. Table 3 lists the various key design parameters determined by assumption or by calculation. Proper utilization of each of the various components in the system insures a safe, reliable, ecologically sound, disposal process.

Operating Criteria

1. Combustion Parameters—In order to operate the fluidized bed incinerator in an efficient ecologically sound manner, close observation of combustion parameters must be made. The proper adjustment of primary and secondary air and the total air flow must be constantly monitored. Laboratory test runs at Exxon Research Corp.

Table 1. Summary of fluidized bed test program

<u>Material</u>	<u>No. of tests</u>	<u>Total duration (hrs)</u>	<u>Quantity burned</u>	
			<u>(lbs)</u>	<u>(kg)</u>
TNT	16	60	47	21
Comp B	2	12	11	5
RDX	6	20	21	10
HMX	7	24	19	9
NH ₄ NO ₃	1	6	--	-
HNO ₃	1	6	--	-
CBI (98% NC)	4	22	19	9

Table 2. Typical combustion emission data

TYPICAL COMBUSTION EMISSION DATA

PARAMETERS

- TEMPERATURE: 1600 – 1850° F
- FEED RATE: 7 LB/HR 10% TNT/WATER SLURRY
- VELOCITY: 4.8 – 5.5 FT/SEC
- THEORETICAL AIR 1 STAGE 2 STAGE
 - PRIMARY 120% 63%
 - SECONDARY 57%

	CATALYTIC	NON CATALYTIC
NO (ppm)	47	800
NO _x (ppm)	57	840
CO (ppm)	40	650
HC (ppm)	10	350
CO ₂ %	12	12
O ₂ %	3.7	4.0

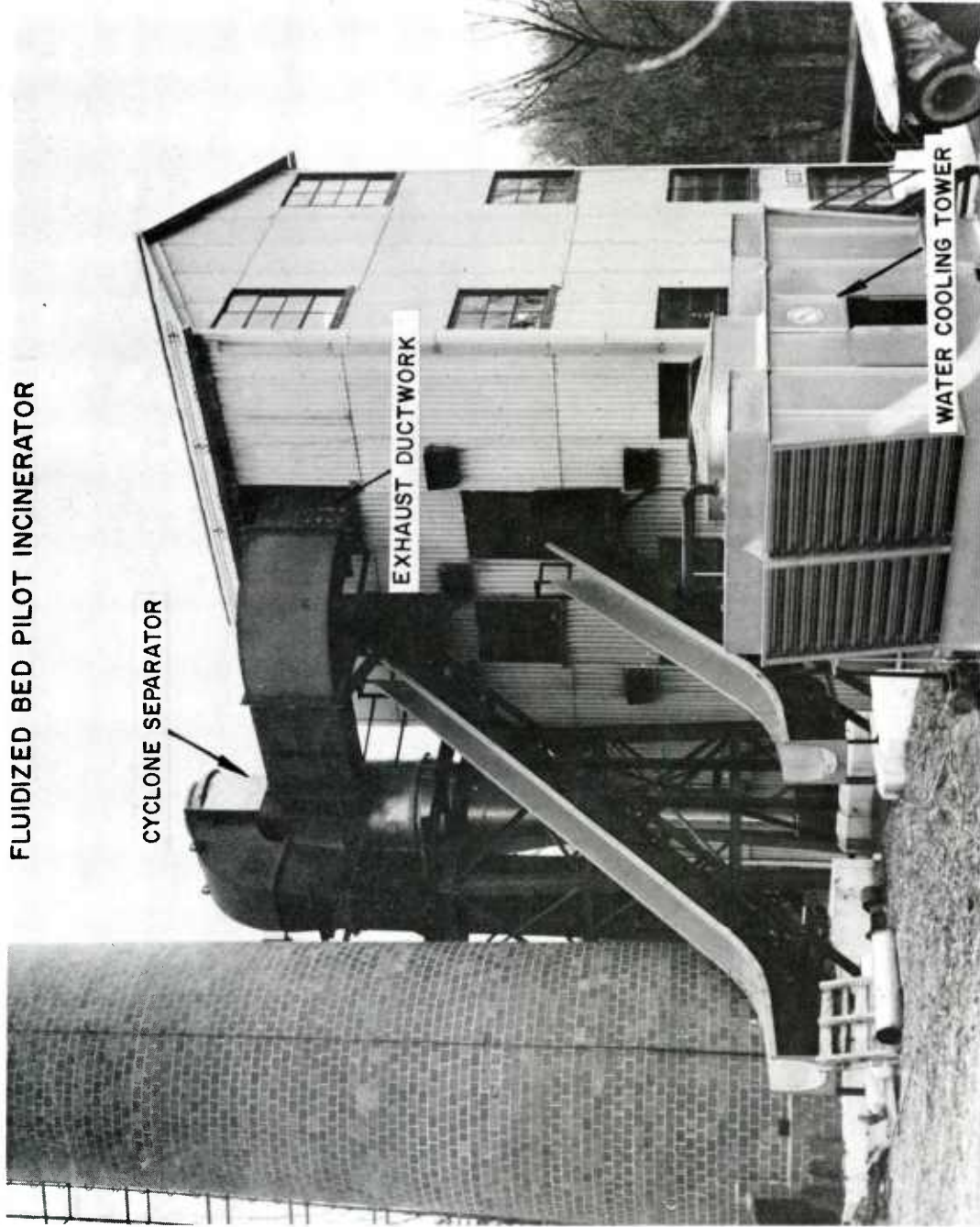

Figure 2. External view of FBI pilot plant.

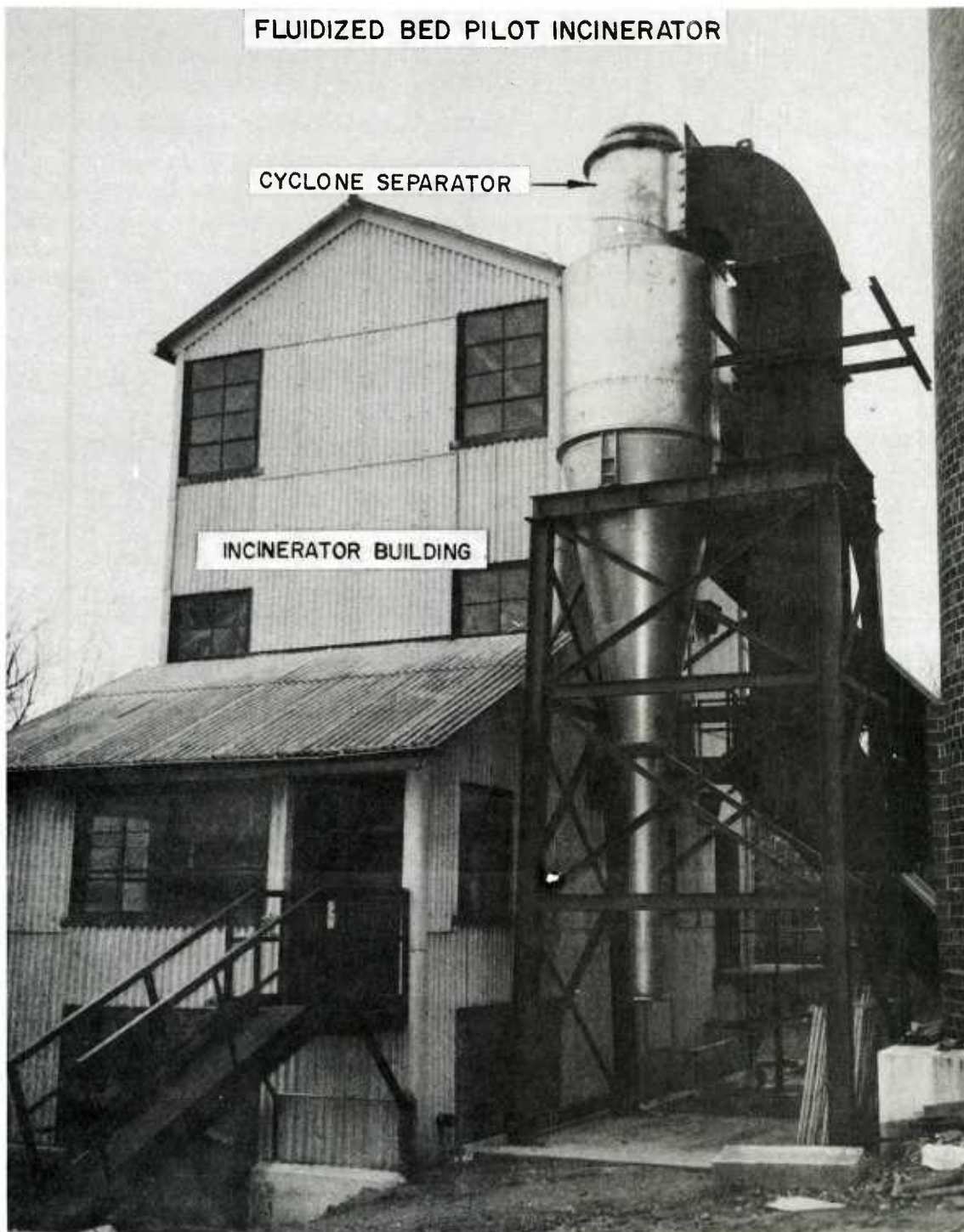

Figure 3. External view of FBI pilot plant (side view).

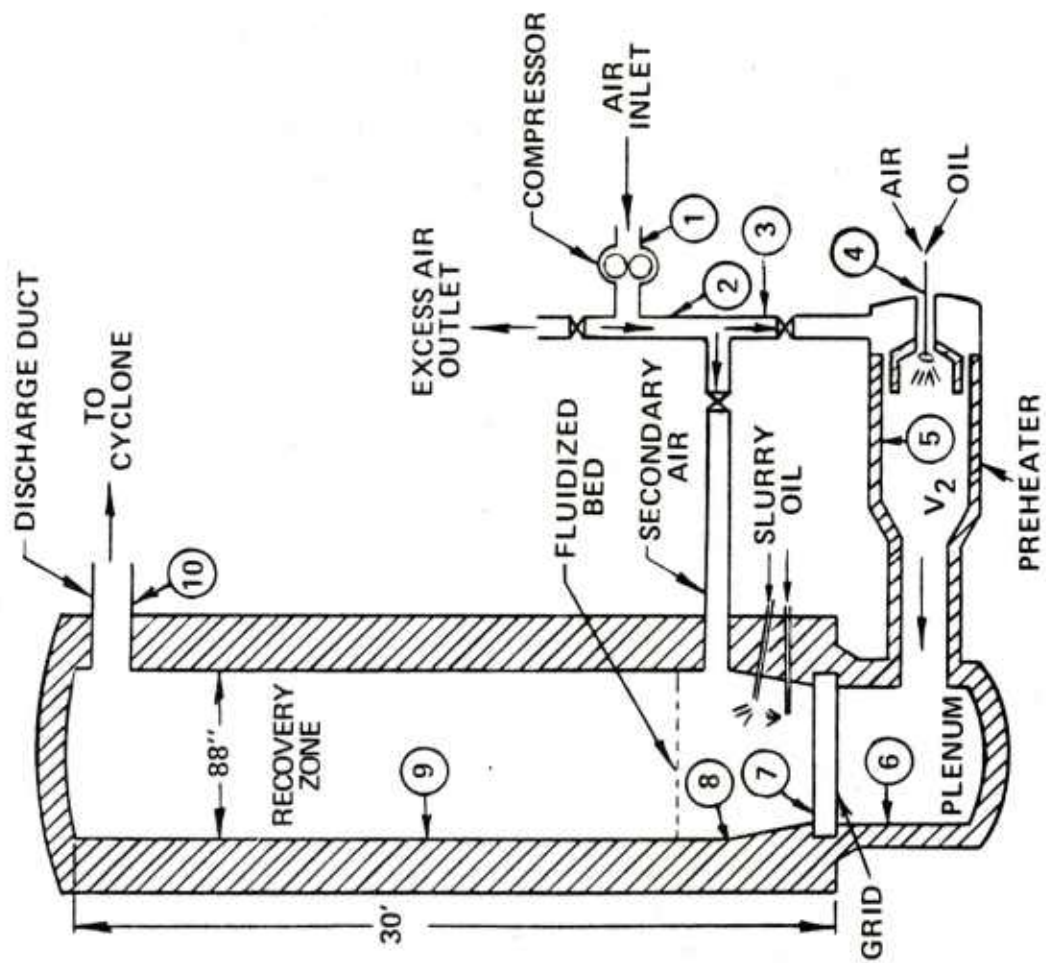

Figure 4. Schematic diagram for determining design operating conditions.

Table 3. Key design parameters

Stations	T _a		P _a (s)	pascals	V _a ft ³ /min	V _a m ³ /sec	W ₀ lbs/hr	W ₀ (s) kg/h
	OF	OC						
1 Compressor inlet	amb		amb	amb	5,800	2.74		
2 Compressor outlet	150	(66)	6.0	(4.14 x 10 ⁴)	5,000	2.36		
3 Fluidizing air feed	150	(66)	6.0	(4.14 x 10 ⁴)	2,180	1.03		
4 Preheater oil/air inlet	150	(66)	6.0	(4.14 x 10 ⁴)	20	0.094	16.5	(7.48)
5 Preheater chamber	1100	(593)	6.0	(4.14 x 10 ⁴)	4,650	2.19		
6 Plenum	1100	(593)	6.0	(4.14 x 10 ⁴)	4,650	2.19		
7 Top of grid	1100	(593)	4.7	(3.24 x 10 ⁴)	4,650	2.19		
8 In fluidized bed	1650	(899)	3.0(5.0)	(2.07 x 10 ⁴)	8,000	3.78	522	(2177)
9 Recovery zone	1650	(899)	3.0	(3.45 x 10 ⁴)	15,200	2.07		
10 Discharge duct	1600	(871)	1.5" H ₂ O	(2.07 x 10 ⁴)	15,200	3.74		

Legend

- T - temperature-OF (°C)
- P - pressure - psig (pascals)
- V - volumetric flow rate - scfm (m³/sec)
- W - weight flow rate - lbs/hr (kg/hr)
- a - air
- o - oil
- s - w/slurry

Station

- Assumed: T_a at station 8
- P_a at station 6
- V_a at station 2

(ref. 1) demonstrated that by operating the fluidized bed (with the catalyst in the bed) with a reducing atmosphere in the main portion of the bed and an oxidizing atmosphere in the upper portion of the bed (via secondary air), optimum combustion occurs.

An equivalence ratio is calculated first for the combustion zone (Φ_1) and then for the overall process (Φ_2). The equivalence ratio is calculated by comparing the actual fuel/air (F/A) ratio to the theoretical ratio as follows:

$$\text{Actual F/A} = \frac{\text{lbs/min oil}}{\text{lbs/min air}} \left(\frac{\text{kg/min oil}}{\text{kg/min air}} \right)$$

For example:

$$\text{lbs/min oil} = \text{gal/min} \times 7.0 \text{ lb/gal}^* \quad (\text{m}^3/\text{sec} \times 4.4 \times 10^{-2} \text{ kg/m}^3)$$

$$\text{lbs/min air} = \text{std ft}^3/\text{min} \times .065 \text{ lb/ft}^3 \quad (\text{m}^3/\text{sec} \times 4.9 \times 10^{-4} \text{ kg/m}^3)$$

$$\text{Ideal F/A} = .068 \text{ for stoichiometric condition (fig. 5)}$$

*Typical values - to be corrected for temperature variations, etc.

$$\text{Equivalence ratio } (\Phi) = \frac{\text{actual}}{\text{ideal}}$$

$$\text{stoichiometric } \Phi = 1$$

$$\text{reducing } \Phi > 1$$

$$\text{excess air } \Phi < 1$$

$$\Phi_1 = \text{conditions in combustion zone (primary air)}$$

$$\Phi_2 = \text{overall conditions (total air)}$$

2. Temperature Ranges—The fuel/air ratios used govern the operating temperatures required for the material being burned. Test results show that for TNT the optimum operating temperature is 1650° F (900° C) in the slurry injection zone. When the system is stabilized at this temperature, the gaseous emissions (particularly NO_x) are at their lowest values. For Composition B, the required temperature is higher at 1900° F (1038° C).

3. Air Pollution—The principle pollutant emissions from waste P&E incinerators are particulates, as dust or smoke, and nitrogen oxides. Sulfur oxide emissions are a function of the amount of sulfur present in the fuel. Combustion of fuel oil, which contains various

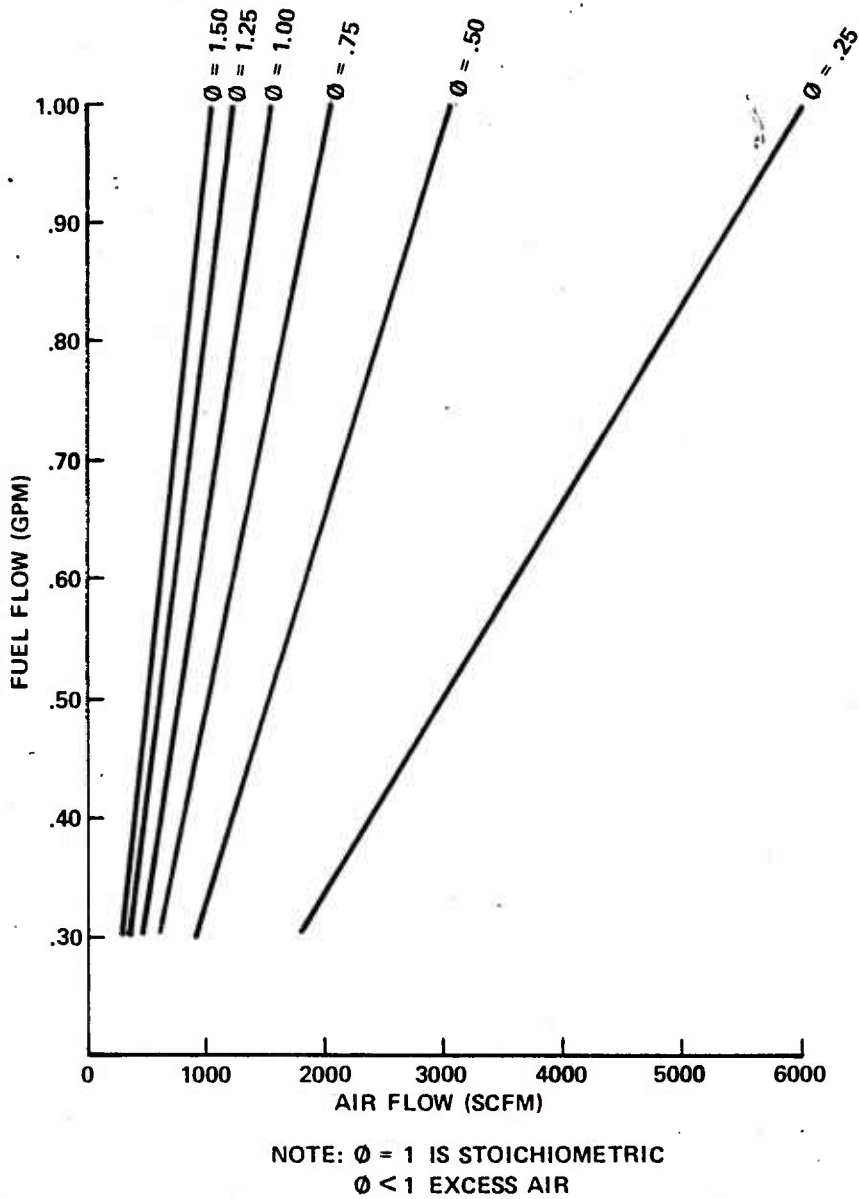

Figure 5. Curves of fuel/air requirements for various equivalence ratios (Φ).

amounts of sulfur, yields significant quantities of sulfur oxides. Nitrogen oxides are formed by the thermal fixation of atmospheric nitrogen in the high temperature process (approx. 15 ppm) and from those nitrogen compounds contained in the materials being burned. Accordingly, the combustion process will produce nitric oxide (NO), which subsequently normally undergoes oxidation to nitrogen dioxide (NO₂). However, in the fluidized bed with its high temperatures, all oxides of nitrogen will exist as NO.

Another gaseous emission, which is of vital interest to efficient combustion, is carbon monoxide. The amount of carbon monoxide emitted relates to the efficiency of the combustion operation, i.e., a more efficient operation will oxidize more of the carbon present to carbon dioxide, reducing the amount of carbon monoxide emitted.

The particulate emissions from the fluidized bed incinerator can be classified as follows:

a. Dust-solid particles which are entrained in the gas stream. These are composed primarily of bed material and approximately 10% catalyst fines, which are generated by attrition in the bed.

b. Smoke-solid particles which are formed as a result of incomplete combustion of carbonaceous materials. While hydrocarbons, organic acids, sulfur oxides, and nitrogen oxides are also produced in the combustion process, only the solid particles resulting from the incomplete combustion of carbonaceous materials are smoke. Smoke particles have diameters ranging from .05 to approximately 1 micron.

4. Heat Transfer—The heat transfer rate in the fluidized bed is considerably higher than in a single-phase gas flow, in any empty tube (or chamber), or in one filled with stationary granular material. The heat transfer rate depends on the fluid velocity and on its thermal conductivity, the size and density of the bed material particles, their thermophysical properties, and those related to the design features of the chamber.

The calculated heat loss from the system, during the 16-hour shutdown period, is 6.6×10^6 BTU (6.96×10^9 J). This is derived from the heat loss through the ceramic (mostly alumina-silica) wall material of 5.5×10^6 BTU (5.80×10^9 J), plus an allowance of 20% (1.1×10^6 BTU) (1.16×10^9 J) for radiation and stack losses. The heat retained in the incinerator system is 18.1×10^6 BTU (1.91×10^{10} J). From the relationship for heat content:

$$\frac{\Delta h_1}{\Delta h_2} = \frac{\Delta T_1}{\Delta T_2}$$

$$\frac{\text{heat in bed}}{\text{heat loss}} = \frac{18.1 \times 10^6}{6.6 \times 10^6} \text{ or } \left(\frac{1.91 \times 10^{10} \text{ J}}{6.96 \times 10^{10} \text{ J}} \right) = \frac{1650^\circ \text{F} - 70^\circ \text{F}}{1650^\circ \text{F} - T_2}$$

$$\text{or } \left(\frac{899^\circ \text{C} - 21^\circ \text{C}}{899^\circ \text{C} - T_2} \right)$$

h = heat

T = temperature

Start temperature, $T_2 = 1100^\circ \text{F} (593^\circ \text{C})$

The above temperature is possible after 16 hrs of shutdown because of the good wall insulating properties, the good heat retention capability of the bed material, and the large heat sink the settled bed provides (22,000 lbs (9979 kg) of alumina). This temperature was verified during the 6-month evaluation period. The heat retained during a weekend shutdown was sufficient to start up without the preheater when work on resumed on Monday.

The heat transfer of the system is affected by the following factors:

a. Materials

(1) fluidizing fluid (air)—thermal conductivity, density, viscosity.

(2) fluidizing particles— thermal conductivity, shape, size, size distribution, density, specific heat.

b. Design of chamber—location and geometry of heat transfer surface.

c. Operating conditions—flow rate of fluids, feed or recycling of solids (via cyclone), bed height, concentration of solids in bed, and characteristics of explosive slurry.

5. Fluidization and Bubble Formation—The fluidized bed incinerator is a cylindrical chamber 8 ft (2.44 m) in diameter and 30 feet (9.14 m) high. It is contained within a metal vessel and its internal activities cannot be seen. Even so, the presence of bubbles can be inferred from the fluctuations in the grid and chamber pressures and the external vibration. These oscillations correspond roughly to the arrival of the larger bubbles at the surface. Bubbles rise by particles flowing around them like a true fluid in streamlike motion. Flow of this kind necessarily produces an upward drift of solids around the vertical axis of the bubble path and a corresponding sinking of the solids. In addition, the bubbles carry a wake of particles, effectively sitting in the bottom of the spheres that define their shape.

The emergence of the bubbles from the grid and their upward rise through the bed is typified by their merging. The merging (growth) of bubbles is mathematically governed by a Fibonacci Series and greatly effects the bed's characteristics. The larger bubbles (2-3 ft or 0.61 - 0.91 m dia) have a higher velocity than the smaller bubbles. It is, therefore, desirable to have more smaller bubbles with slower velocities (longer residence times) than larger ones. The diameter of the bubbles can be controlled by correct grid design, baffles, or both.

Incipient fluidization is generally intended to refer to the upward superficial velocity of bubbles through a bed of particles at which the pressure drop is equal to the weight of the bed. It is the rising of the bubbles that creates the tremendous mixing action in the fluidized bed. As a bubble rises, the bed material (alumina) replaces its volume, with the greatest mixing occurring with the maintenance of smaller diameter bubbles.

6. Elutriation—This is the entrainment of relatively small particles in the air leaving the upper surface of a fluidized bed. This occurs as the air flow rate is increased beyond the minimum fluidization (incipient) value and the bed becomes more and more intensely fluidized.

This phenomenon plays a significant role in fluidized bed technology because of the wide range of particle sizes in the bed. Furthermore, the bed material and catalyst, when fluidized, undergo attrition which leads to the formation of fines. These fine materials are readily picked up by the fluid and conveyed away when the fluidizing (superficial) velocity exceeds the terminal velocity of the particles. Due to environmental requirements, these fine components must be removed prior to the discharge of the exhaust gases into the atmosphere.

Elutriation of fine particles from the fluidized bed may be explained based on the formation and rising of bubbles through the bed. The bubbles are formed just above the grid and rise upward carrying with them the fines as well as the coarse particles through the fluidized bed. The solids around and behind the bubbles may be carried up in the bed at a velocity considerably higher than the superficial gas velocity.

It has been found that a broad range of particle sizes gives better fluidization than a narrow range, and that fine materials are better than coarse ones. Therefore, elutriation is an important factor in the fluidized bed, since the bed is constantly changing (size distribution of the particles) and the entrained particles aid in the undesired erosion of exhaust ductwork, cyclone, etc. The efficiency of the recovery equipment (cyclone) determines the lower

limit of the equilibrium particle size range, while the upper limit is set by the fresh feed stock of bed material. This is further affected by the attrition rate of the system.

In summary, the factors that effect elutriation are:

- a. fluidizing air (bubbles) distribution and velocity
- b. bed height
- c. chamber diameter
- d. freeboard or transport disengaging height (TDH).

Equipment

In the development of the fluidized bed incinerator, various subsystems had to be designed. The preheater, blower, grid, cooling tower, chamber, and cyclone were sized to accommodate the required air flows and feed rates (slurry and fuel). The exhaust gas monitoring system was designed to sample critical exhaust gases and to operate at various conditions and ranges. Details of these systems are addressed in Appendix B.

Slurry Preparation and Feed System

This system consists of two 420 gallon (1.59 m^3) tanks, pneumatic mixers, valves, and pumps. The system has the capability to mix, recycle, and pump various explosive slurries (fig. 6). The entire system is remotely operated and monitored, 250 ft (76.2 m) away in the control room (fig. 7).

The tanks are loaded with water and then the mixers are started. After the water is in motion, the explosive material is added to the tank. When the material is all added, the short recycle line is activated; when that flow is stabilized, the large recycle line is opened. The flow of the slurry in the $2\frac{1}{2}$ in. (0.064 m) header pipe is adjusted from the control room by varying the pressure on the $2\frac{1}{2}$ in. (0.064 m) flow control valve. The slurry piping system should have a minimum diameter of 4-6 times the particle size being pumped. The current slurry system includes a $2\frac{1}{2}$ in. (0.064 m) slurry header system from the pump house and $\frac{1}{4}$ Schedule 40 pipe (0.364 in. ID). For a particle size of 0.1 in. (0.0025 m) diameter, this size pipe is marginal.

The mixers are operated with a 1 hp (735.5 W) pneumatic motor. They are adjusted for each individual slurry mix and as the liquid level changes. The varying densities of the different slurries, due to their compositions, weight percentages, and particle configuration,

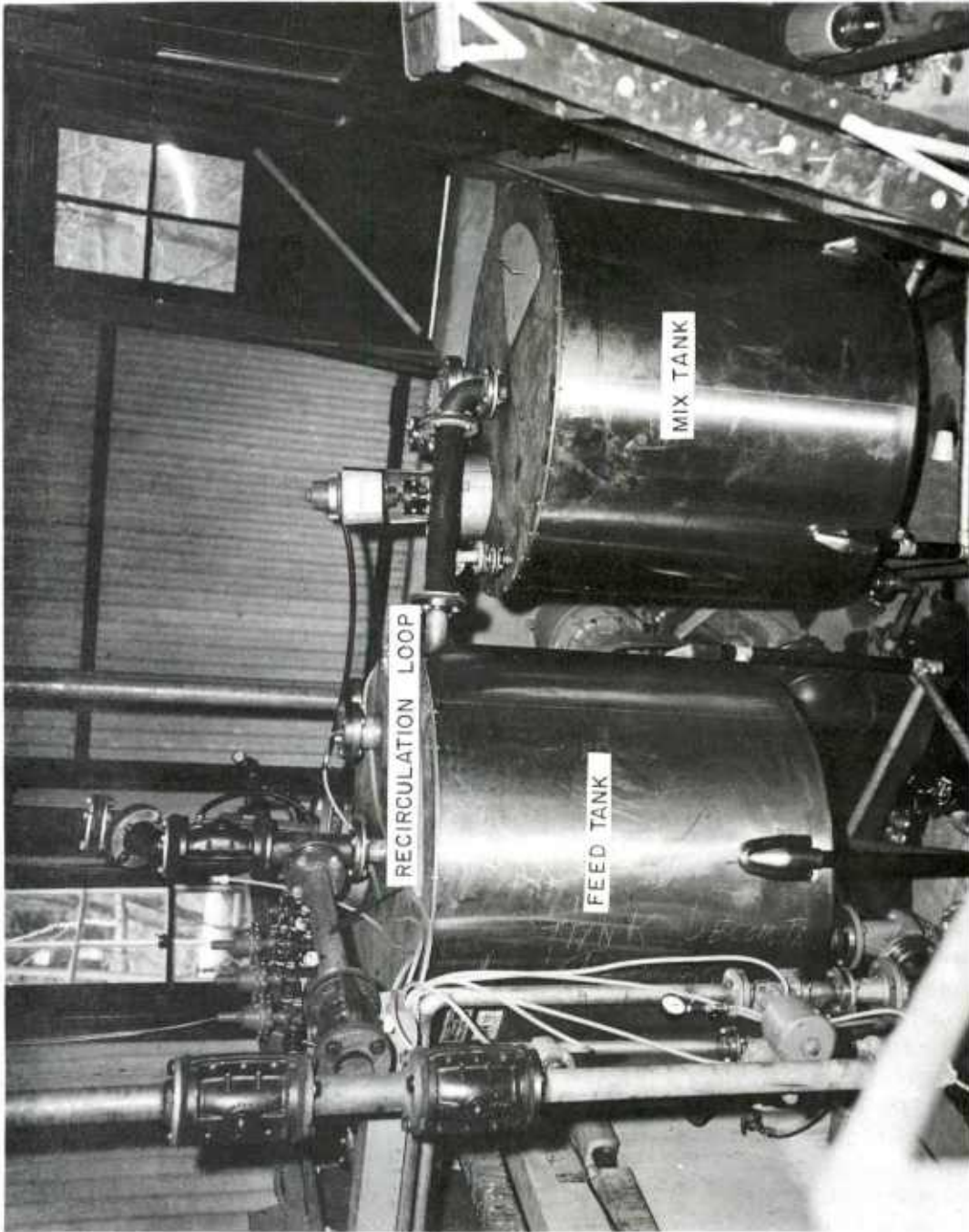

Figure 6. Slurry mixing and pumping facility.



Figure 7. Control panel for slurry preparation and feed system.

present different mixing parameters to be taken into account. When progressing through a run, the liquid level changes, and a new environment is present in the tank. The current system allows for this by having a hi-low range for the mixers. When the tank is full, the mixers are operated at high speed (60-80 psi or 4.14×10^5 - 5.52×10^5 Pa). As the level decreases, the speed changes to low (25-40 psi or 1.72×10^5 - 2.76×10^5 Pa). This change prevents "over mixing" the slurry and decreases the possibility of starving the pump.

The slurry pump is of the centrifugal type and capable of pumping a 60 ft (18.3 m) head with a flow of 125 gal/min ($0.0079 \text{ m}^3/\text{sec}$) of water. The pump's clearance must be checked to assure that the maximum performance can be achieved. As the densities of the materials increase, this becomes even more important. A careful watch is kept on the monitoring equipment, especially the pump discharge pressure. This allows the operator to determine if the pump is being influenced by the mixers (entrained air) and as a check of slurry density.

2. Instrumentation

a. Temperature—Temperatures of the fluid bed system are monitored throughout the chamber at various heights and also in the slurry injection coolant lines.

The bed temperatures are carefully monitored (fig. 8) to determine where the fuel oil and/or slurry are combusting, because close control is required to prevent combustion from occurring above the bed or in the exhaust ducts. The injection of the oil and slurry into the bed are controlled by individual "approval switches" set at predetermined minimum combustion temperatures in the bed. This prevents the oil and slurry from being fed into the bed until combustion temperatures are attained.

The temperature of the cooling water in the slurry injection gun is also monitored to determine if the cooling tower is functioning or if there is a clogged or pinched line.

b. Pressure

Chamber—The pressure is monitored at four positions in the chamber: in the plenum, at the grid, in the bed, and in the upper chamber. By observing the plenum and grid pressures, a check can be made on fluidization and also on the grid itself for determination of whether or not the grid nozzles are clogged. Similarly, by examining the grid and bed pressure readings, the degree of fluidization and bed height can be calculated (fluidization pressure drop (ΔP) \approx bed wt/area). The pressure transmitters can also detect any pressure buildup in the system and possible detonations.



Figure 8. Incinerator instrumentation and control panel.

Slurry injection system—The pressures in the slurry system are monitored at three points:

(1) Pump discharge—This shows if the pump is operating at the full rated capacity or possibly being affected by the action of the mixers in the slurry tank. Another use for this reading is as a rough approximation of the density of the material being pumped. The increase or decrease of pressure from that of water can be related to changes in density as follows:

$$\text{density } (\rho) = \frac{\text{psig (2.31)}}{\text{disc. head}^*} = \frac{\text{pascals (0.704)}}{\text{disc. head}^*}$$

*for water

(2) Header—This pressure is critical to determine if the flow through the 2½-in. diameter (0.064 m) pipe is sufficient to prevent particle dropout and to insure that the pressure is high enough to produce flow in the slurry line. This pressure is controlled by a combination orifice plate and pneumatic flow control valve. The orifice plate maintains the pressure at the minimum safe pressure and the flow control valve is used for making adjustments to compensate for pressure changes due to the slurry density changes (fig. 9).

(3) Slurry line—This helps establish if there is flow in the line and also provides additional benefits in detecting and cleaning clogged slurry lines.

c. Flow

The monitoring of slurry flow is mandated by the hazardous nature of the materials being pumped. A close scrutiny is required of both the actual flow and concentration of the slurry in the system. This is achieved by utilizing the aforementioned pressure transmitters (header and slurry line) and a differential pressure (D/P) cell. The pressures sensed off the header and slurry line transmitters are sent to the D/P cell, the pressures are compared, and an output signal is sent to a chart recorder (fig. 10).

By establishing a flow curve for each slurry concentration and material (weight vs density), the recorder can be used to determine flow rates and, therefore, mass flow (fig. 11).

This system is also an invaluable aid in determining the status of the flow during the run. Not only does it reflect the slurry flow, but also any potential problem that may arise due to clogging.

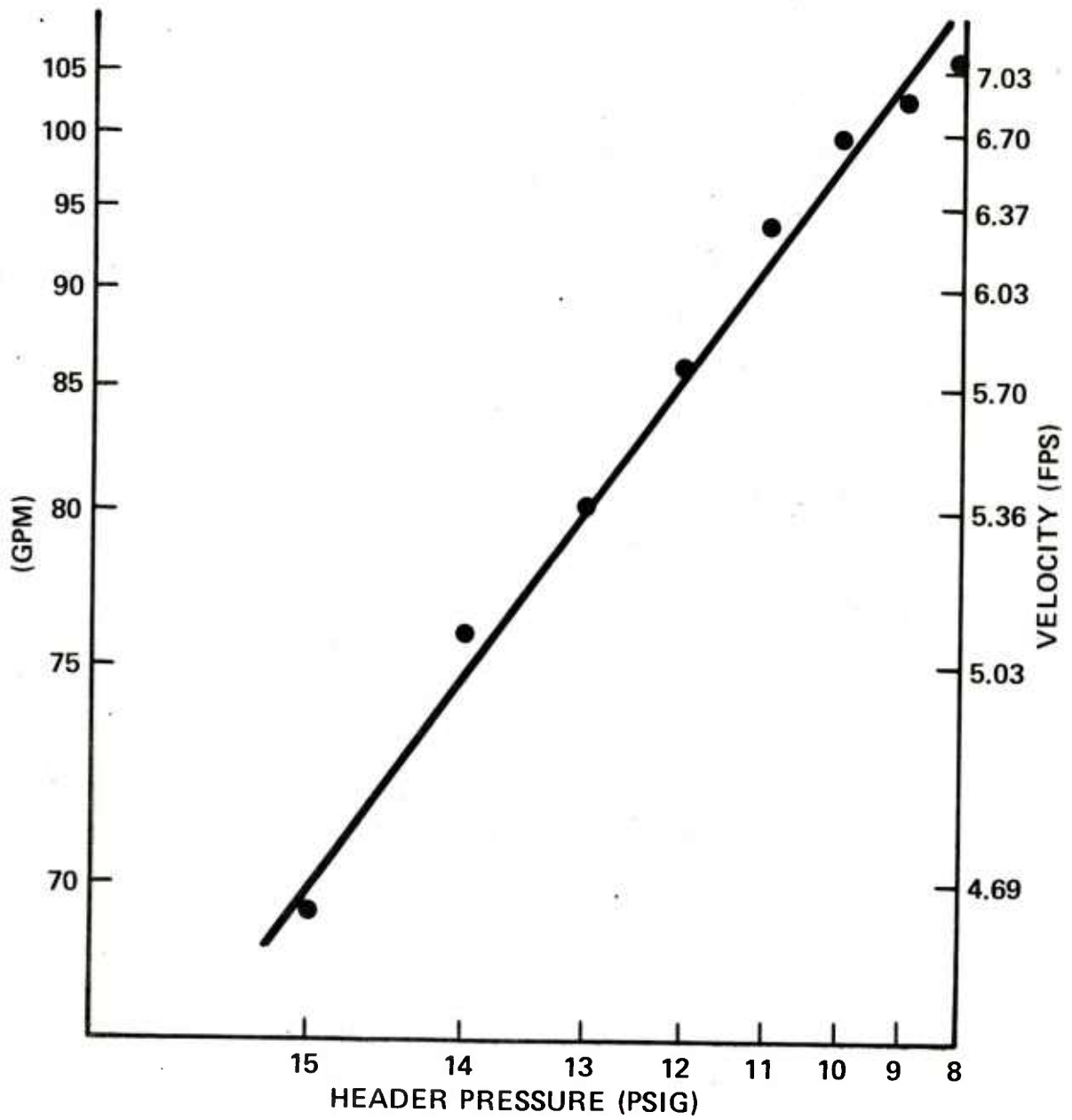

Figure 9. Curve of slurry flow rate and velocity vs header pressure.

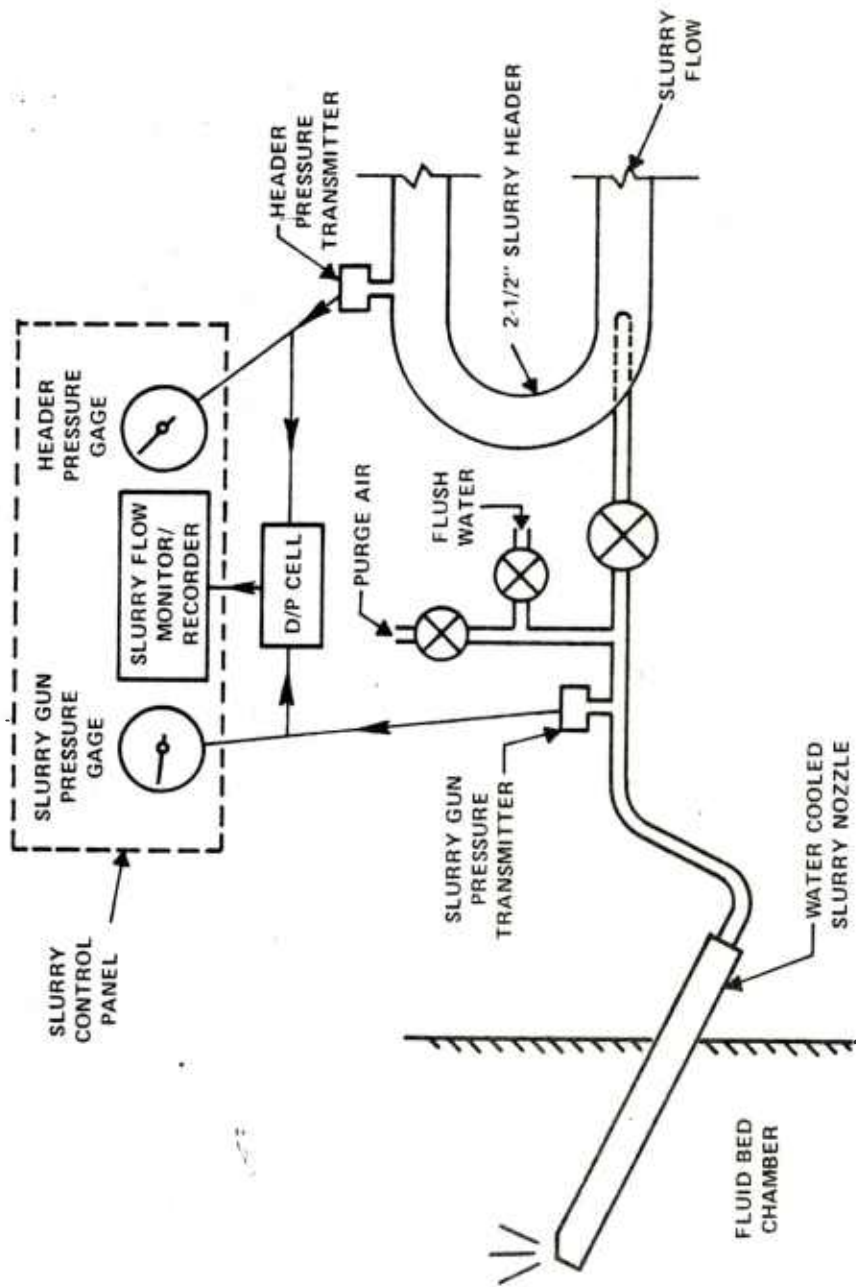

Figure 10. Slurry injection and monitoring system.

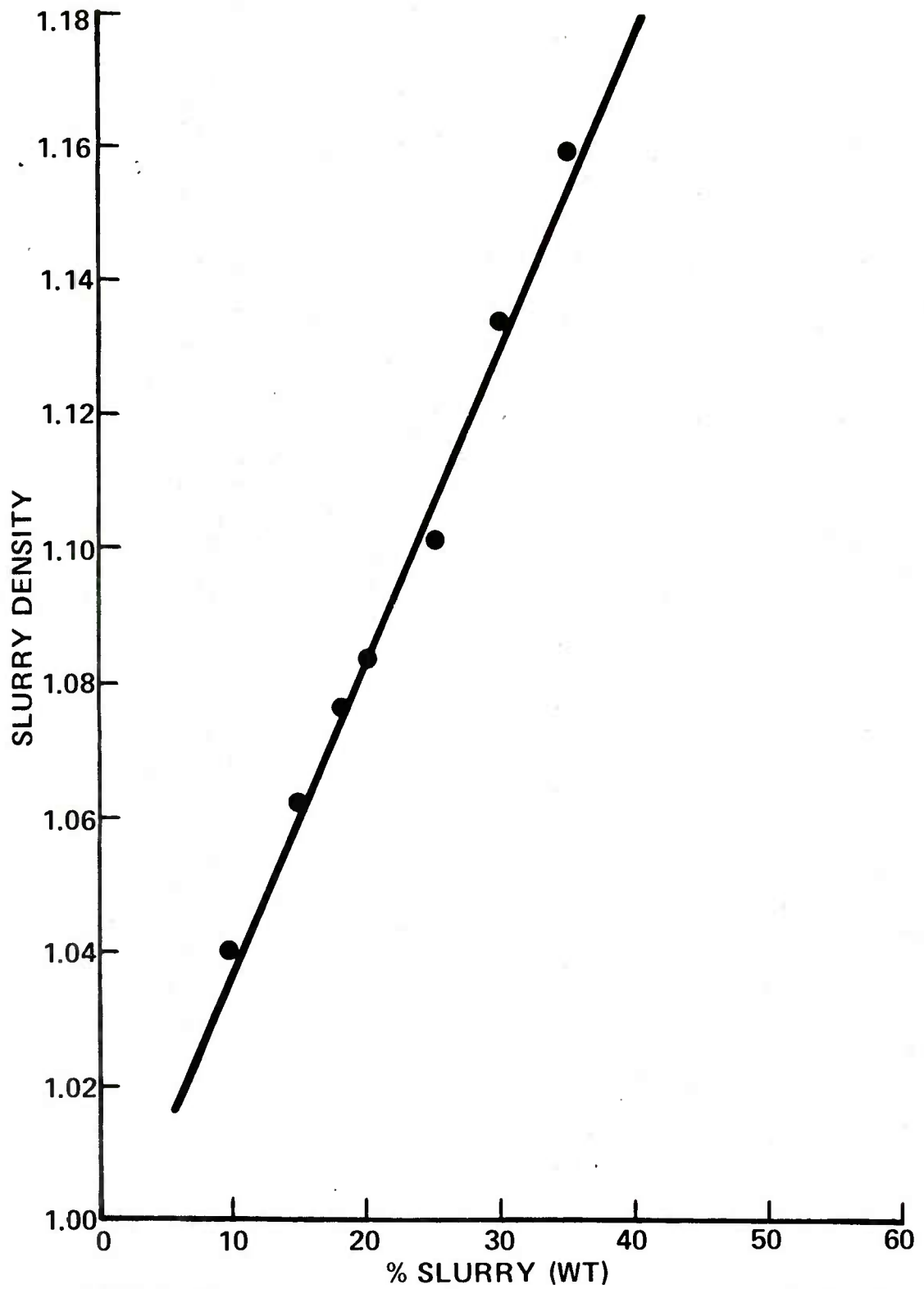

Figure 11. Curve of slurry density vs weight percent slurry.

If the recorder peaks either up or down, it means a large particle or group of particles is passing through the system, and a quick pulse of high pressure flush water is sent through the system, by the operator, to prevent the line from clogging. If a line does clog, it will be reflected by the recorder with either a 0 (min) or 10 (max) on the chart (figs. 12 & 13). A 10 will indicate that the plug is at the nozzle or at a point below the pressure sensor (transmitter); a zero will mean that it is above the sensor. This greatly aids the explosive operator in cleaning a clogged system.

The system, as designed, is invaluable for:

- a. detecting flow
- b. measuring flow
- c. troubleshooting and cleaning a clogged slurry line.

Economic Analysis

In the evaluation of alternate systems, it is necessary to consider the economic factors associated with each system. The economic analysis of the fluidized bed incinerator versus the rotary kiln incinerator was performed by the Mobility Equipment Research and Development Command (MERADCOM) under the direction of ARRADCOM (ref. 2). The method utilized by MERADCOM to perform this analysis is the present value unit cost (PVUC) method, which complies with AR 37-13.

This method utilizes a computerized mathematical model to economically evaluate alternate incinerator designs. The model considers capital costs, operating costs, time horizons, depreciation, interest, and other related factors (fig. 14). The output yields the PVUC per pound of material incinerated. The PVUC program is used to evaluate the cost parameters of the fluidized bed versus the rotary kiln over various time horizons and load (operating) rates. The data generated from two typical runs (250 and 1000 lbs/hr) are shown in tables 4 and 5, and figures 15 and 16. The TNT/slurry weight ratio is 25 percent for these calculations. The data used for the analysis is derived from actual pilot plant testing. The rotary kiln data is obtained from runs at 250 lbs/hr and the fluidized bed data from runs at 177 lbs/hr (250 lbs/hr at 67%).

By inspection of the tables, it can be seen that the cost savings that can be realized using the fluidized bed incinerator varies from \$19,000/yr up to \$193,000/yr with a 250 lb/hr capacity and from \$108,000/yr to \$311,000/yr with a 1000 lb/hr capacity. The major cost

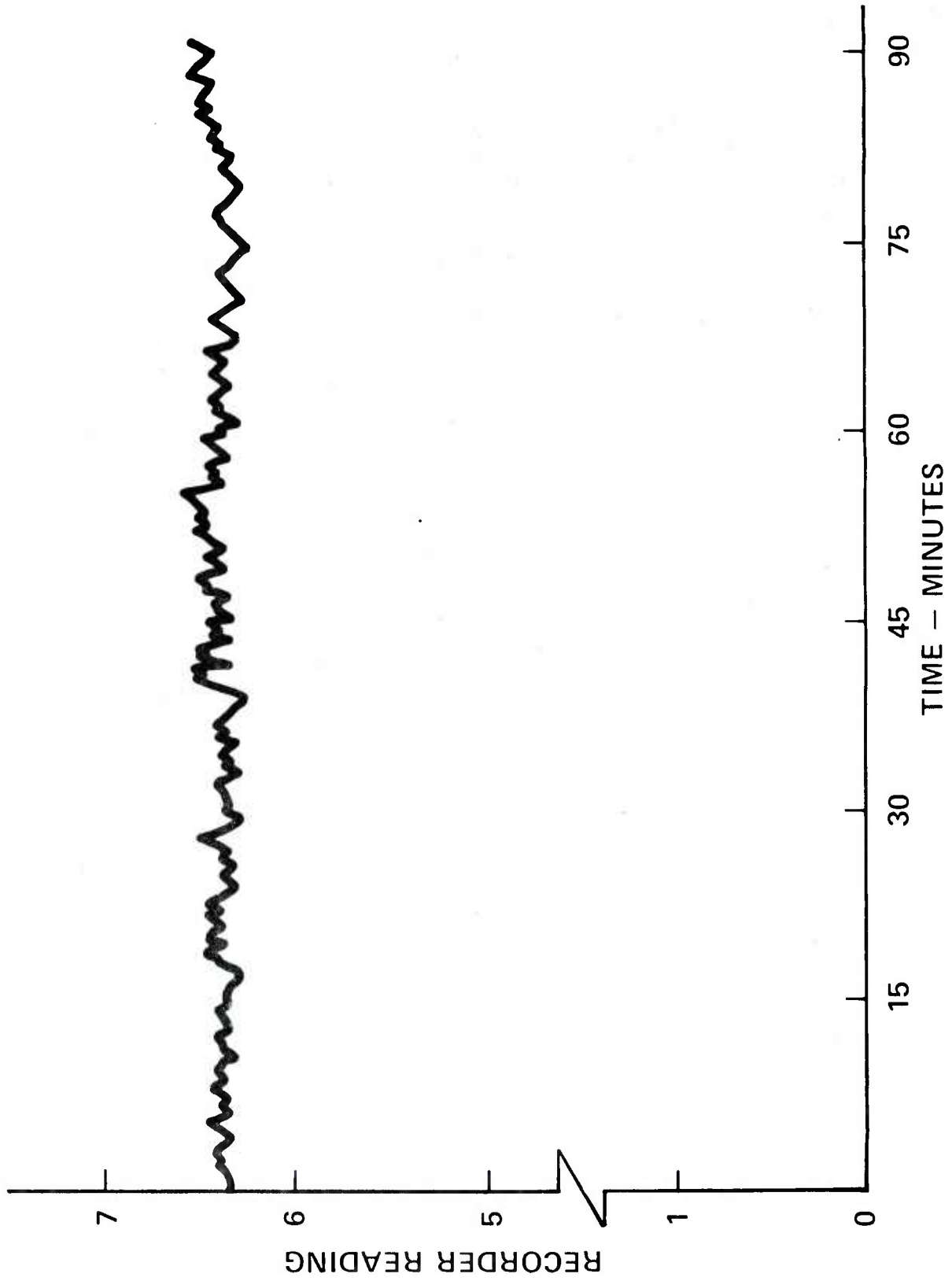

Figure 13. Typical "slurry flow monitor" recorder trace (flow: 3.5 gal/min of slurry).

DESIGN CAPACITY

OPERATING CAPACITY

TIME HORIZONS (5, 10, 15, 20, 25 YRS)

CAPITAL EQUIPMENT:

- **ECONOMIC LIFE - 25 YRS**
- **DEPRECIATION RATE - STRAIGHT LINE**
- **INTEREST - 10%**
- **SALVAGE VALUE**

OPERATING COSTS

Figure 14. Economic analysis factors.

Table 4. Cost factors for the 250 lb/hr case

Yr	Design Capacity (#/hr)	Oper. Rate (%)	Oper. Burned (#/day)	Oper. Schedule	Rotary Kiln Oper. Cost (\$/day)	Fluid Bed Oper. Cost (\$/day)	PVUC Rotary Kiln \$/# Expl	PVUC Fluid Bed \$/# Expl	Cost Savings \$/day	Cost Savings \$/yr*
5	250	33	2000	1/8/5	276.19	141.43	.26358	.22520	76.76	19,190.
10							.25633	.21629	80.08	20,020.
15							.25046	.20906	82.80	20,700.
20							.24581	.20333	84.96	21,240.
25							.24222	.19891	86.62	21,655.
5	250	66	4000	2/8/5	567.03	255.09	.20450	.14102	253.92	63,480.
10							.20088	.13656	257.28	64,320.
15							.19794	.13294	260.00	65,000.
20							.19562	.13008	262.16	65,540.
25							.19382	.12787	263.80	65,950.
5	250	100	6000	3/8/5	1027.63	347.76	.21310	.10946	621.84	155,460.
10							.21038	.10649	625.14	156,285.
15							.20873	.10407	627.96	156,990.
20							.20718	.10217	630.06	157,515.
25							.20598	.10069	631.74	157,935.
5	250	100	6000	3/8/6 MOB	1027.63	344.73	.20479	.09872	636.42	190,926.
10							.20285	.09634	639.06	191,718.
15							.20128	.09441	641.22	192,366.
20							.20004	.09288	642.96	192,888.
25							.19908	.09170	644.28	193,284.

*250 days - (Standard Work Week)
 300 days - (MOB - 6 Day Work Week)

Capital Equipment Cost FBI - \$582,000
 RK - \$472,000

Current Year Dollars - FY74 Base

Table 5. Cost factors for the 1000 lb/hr case

Yr	Design Capacity (#/hr)	Oper. Rate (%)	Quan. Burned (#/day)	Oper. Schedule	Rotary Kiln Oper. Cost (\$/day)	Fluid Bed Oper. Cost (\$/day)	PVUC Rotary Kiln \$/# Expl	PVUC Fluid Bed \$/# Expl.	Cost Savings \$/day	Cost Savings \$/yr*
5	1000	33	8,000	1/8/5	815.20	282.12	.14212	.08784	434.24	108,560.
10							.13980	.08481	439.92	109,980.
15							.13792	.08235	444.56	111,140.
20							.13643	.08040	448.24	112,060.
25							.13528	.07889	451.12	112,780.
5	1000	66	16,000	2/8/5	1165.49	459.05	.09296	.05498	607.68	151,920.
10							.09179	.05346	613.28	153,320.
15							.09085	.05223	617.92	154,480.
20							.09011	.05126	621.60	155,400.
25							.08953	.05050	624.48	156,120.
5	1000	100	24,000	3/8/5	1649.51	554.51	.08214	.04063	996.24	249,060.
10							.08136	.03962	1,001.76	250,440.
15							.08074	.03880	1,006.56	251,640.
20							.08024	.03815	1,010.16	252,540.
25							.07985	.03765	1,012.80	253,200.
5	1000	100	24,000	3/8/6 MOB	1649.51	548.63	.07947	.03690	1,021.68	306,504.
10							.07885	.03609	1,026.24	307,872.
15							.07835	.03543	1,030.08	309,024.
20							.07795	.03491	1,032.96	309,888.
25							.07765	.03451	1,035.36	310,608.

*250 days - (Standard Work Week)
300 days - (MOB - 6 Day Work Week)

Capital Equipment Cost: FBI - \$792,000
RK - \$606,000

Current Year Dollars - FY 74 Base

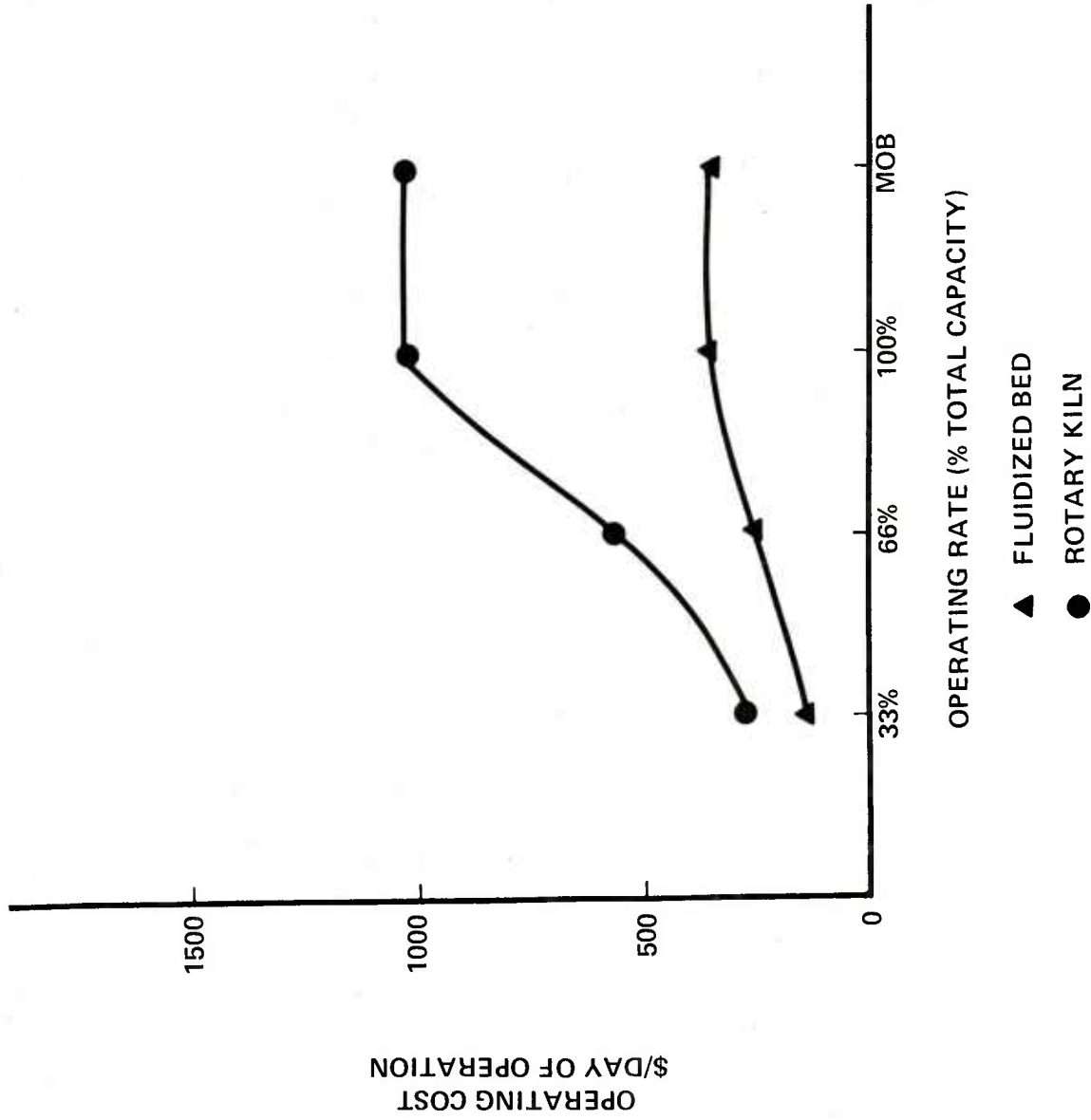

Figure 15. Comparison of operating costs (250 lb/hr).

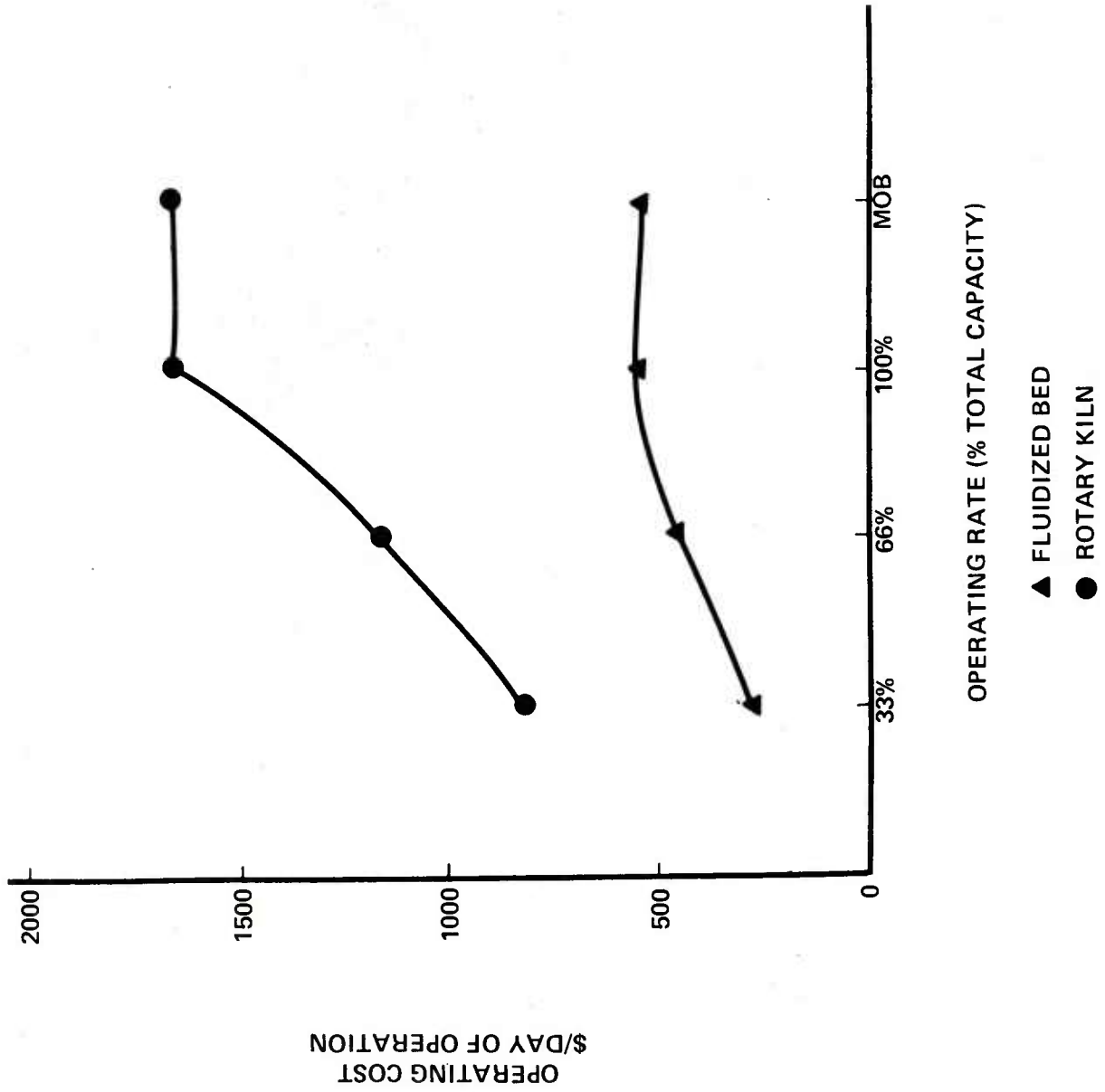

Figure 16. Comparison of operating costs (1000 lb/hr).

saving attributed to the fluidized bed when compared to the rotary kiln is due to the lower operating costs.

A discriminant, δX_j , which is the PVUC difference between the two alternatives, is evaluated to become the quantified decision indicator denoting the practicability of selecting between Alternative A (rotary kiln) and Alternative B (fluidized bed). The calculation of the discriminant is as follows:

$$\delta X_j = \frac{X_j^A - X_j^B}{K_j^A}$$

where,

X_j^A = PVUC of Alternative A for the j case

X_j^B = PVUC of Alternative B for the j case

K_j^A = Capital cost of Alternative A for the j case.

By examining the above equation, it can be seen that a positive discriminant reflects that Alternative B (fluidized bed) is the desired choice. A review of all the cases considered and evaluated, indicated that the fluidized bed is the preferred alternative.

The sensitivity of the discriminant to variations in the capital costs for the fluidized bed alternative was calculated as shown in table 6. These values show how the decision discriminant varied in response to selected percentage increases in the capital costs of this alternative. This may also be regarded as the variation in the difference between the capital costs of both alternatives.

In this case, it shows (by means of a positive discriminant) that even given a percentage increase in the capital costs of Alternative B, the fluidized bed is still favored over the rotary kiln. Upon close examination of the table, it can be determined that the major factor affecting the PVUC value is the operating costs and not the capital costs. For example, a 40% increase in the capital cost differential reflects only a 13% change in the discriminant.

The PVUC model can be used to evaluate any number of alternative designs provided sufficient operating data is available. For example, listings of required costs parameters for the evaluation of the different incinerator systems are shown in figure 17. By utilizing this

Table 6. Sensitivity analysis for variations in capital costs

250 #/HR CASE

<u>Year</u>	<u>PERCENTAGE INCREASE IN CAPITAL COST DIFFERENTIAL</u>				
	<u>0%</u>	<u>25%</u>	<u>30%</u>	<u>35%</u>	<u>40%</u>
5	1.68	1.54	1.51	1.48	1.45
10	2.73	2.50	2.45	2.41	2.36
15	3.39	3.11	3.06	3.01	2.95
20	3.81	3.51	3.45	3.39	3.33
25	4.06	3.76	3.70	3.63	3.57

Note: Table values indicate discriminant variations.

- PREPARATION LABOR COSTS OVER OTHER SYSTEMS (FLUID BED, ROTARY KILN)
- LABOR DURING DOWNTIME
- NO. OF BURNS AND QUANTITY DISPOSED OF PER DAY (8 HR. SHIFT)
- RAW MATERIALS (INCL REPLACEMENT PARTS)
- UTILITIES
- LIFE CYCLE OF EQUIPMENT
- EQUIPMENT COSTS

36

OTHER DECISION MAKING COST FACTORS

P & E PREPARATION - MOTOR/GRINDER, FEED MECHANISM, WATER, DEWATERING SYSTEM, DRYER.

SITE PREPARATION - ACCESS ROADS, ELECTRICAL POWER, WATER, COMPRESSED AIR, SANITARY SEWERS, LIGHTING, TELEPHONE, DRAINAGE.

Figure 17. Factors for PVUC economic analysis (AR, 37-13).

this program, sufficient economic data is generated to provide management with a viable decision-making tool when choosing between various process alternatives.

DISCUSSION OF RESULTS

The test program for the fluidized bed incinerator was accomplished in three phases: checkout and debugging, explosive disposal without catalyst, and explosive disposal with catalyst. Following construction of the incinerator by the U.S. Army, a series of test runs was made to check out and debug the system. These tests were also used to train and familiarize test operators on the operation and maintenance of the various incinerator systems. Incinerator operating parameters were varied to observe the effects on combustion efficiency and temperature control. The test plan delineated that changes be made to the operating conditions at planned intervals during a test burn, while injecting water into the incinerator. Some of the parameters varied were fluidizing or primary air, secondary air, fuel oil feed, fuel/air ratio, and temperature. In addition, the safety controls and instrumentation were fully checked and tested to insure safe operation of the incinerator system. Some of the more important controls involved were: (a) temperature-approval controls that would allow fuel or slurry injection into the incinerator only if set temperatures were achieved, (b) temperature controls to shut down the system if maximum set temperatures were exceeded, and (c) automatic air and water purges of the oil and slurry systems.

The first two series of tests were run without the catalyst in the bed. Emission monitoring was performed by Exxon Research and Engineering Company, with the exhaust gas sampling done at the top of the incinerator. The test series included disposal of explosive slurries containing 15% and 20% TNT in water at feed rates of 170 to 248 lbs/hr (77.1 - 112.5 kg/hr) of TNT. The results of the tests were as expected (table 7). The data indicated that the combustion of the TNT was smooth and that it was burning through the lower portion of the fluidized bed. The incinerator temperatures took an initial dip when the slurry was first introduced and then recovered and remained relatively constant throughout all the test runs (fig 18). The stack emissions were also within the predicted range. The NO_x emissions averaged 828 ppm (275 - 1881 ppm), while the average values of HC and CO were 9 ppm and 58 ppm, respectively. This data fell within the range of emissions recorded during incinerator testing on the rotary kiln, the PA vertical incinerator, and the pilot fluidized bed incinerator.

Table 7. Selected data from Exxon Research & Engineering Co. monitoring (without catalyst)

Run no.	% TNT	Disposal rate		Primary air		Secondary air		In-bed fuel		Equivalence ratio		NO _x ppm	HC ppm	CO ppm
		lb/hr	kg/hr	ft. ³ /min	m ³ /sec	ft. ³ /min	m ³ /sec	gal/min	m ³ /sec	φ ₁	φ ₂			
17	water	0	-	3400	1.6	0	0	1.26	7.9	0.53	--	--	--	--
18	water	0	-	1250	0.6	1000	0.5	0.90	5.7	1.04	0.58	--	--	--
19	water	0	-	2500	1.2	0	0	1.00	6.3	0.58	--	19	2.0	20
21	15	170	77	1500	0.7	1000	0.5	0.85	5.4	0.82	0.49	1015	4.5	40
23	15	170	77	2400	1.1	0	0	0.85	5.4	0.51	--	540	4.5	35
24	15	170	77	2000	0.9	500	0.2	0.85	5.4	0.61	0.49	423	4.6	32
27	15	177	80	1600	0.8	0	0	0.73	4.6	0.66	--	420	48.0	110
29	20	244	111	1200	0.6	1000	0.5	0.80	5.0	0.96	0.52	1070	8.6	70
31	20	244	111	800	0.4	400	0.2	0.80	5.0	1.45	0.97	755	5.3	39
32	20	235	107	1300	0.6	0	0	0.40	2.5	0.45	--	1625	7.9	62
35	20	248	112	1000	0.5	750	0.4	0.70	4.4	1.01	0.58	765	7.3	80

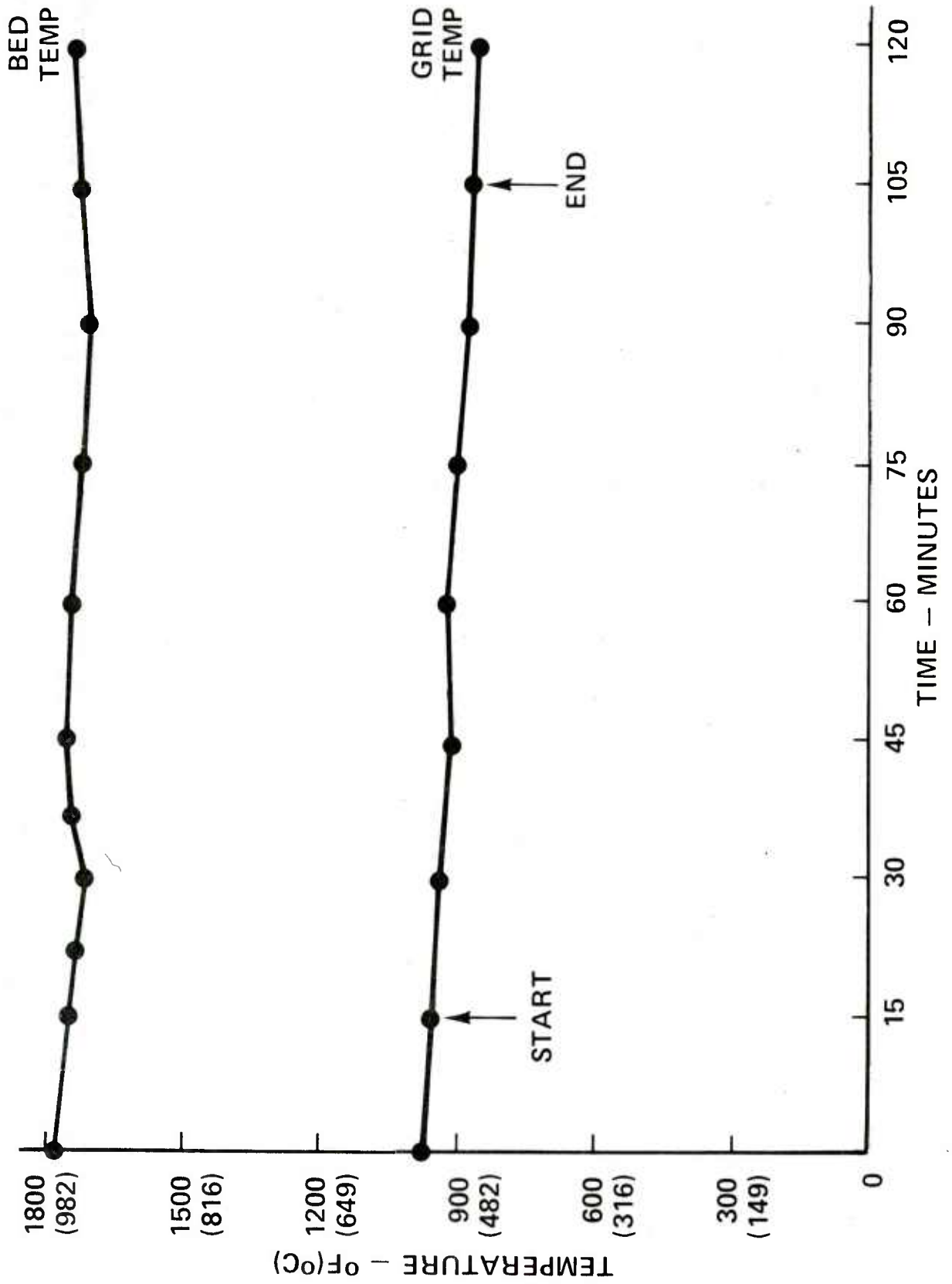

Figure 18. Typical recorder trace of FBI grid and bed temperatures during test run.

Phase three of this effort, explosive disposal with catalyst, was accomplished with three series of tests. The first series used Scott Environmental Technology, Inc. (SETI) to perform the stack gas monitoring and analysis. The U.S. Army Environmental Hygiene Agency (AEHA) performed these services for series 2 and 3. All of the gas monitoring in this phase was done using sampling ports in the exhaust duct that ran from the top of the cyclone to the bottom of the stack. It was determined, by AEHA, that this sampling port would be acceptable for compliance testing and/or sample point for the Peerless stack gas monitor.

Before performing explosive burning tests with the catalyst in the bed (SETI did the stack sampling), 13 tests were performed without the catalyst to correlate the data with that from Exxon Research Co. In five tests, plain water was injected into the incinerator. Explosive slurries of 15% and 20% TNT in water were burned at feed rates of 177 to 233 lbs/hr (80.3 - 105.7 kg/hr) during the remaining eight tests. The results of the tests (table 8), showed that the average NO_x levels of 429 ppm (280-580 ppm) and the average value of HC and CO of 1 ppm and 42 ppm respectively, were within acceptable limits of comparison between the two sets of data acquired from the different sampling points. The wide variation in the Exxon Research data was probably due to the sampling being done at the top of the incinerator where stratification could take place with poor mixing of the exhaust gases. At this point, 3000 lbs (1360 kg) of nickel oxide catalyst were added to the fluidized bed, and 18 tests were performed at explosive disposal rates varying from 177 to 340 lbs/hr (80.3 - 154 kg/hr) with TNT/water slurries containing 15 to 25% TNT. The results of this first series of tests were very good (table 8). The average NO_x emission was 348 ppm (16 ppm - 800 ppm) with the HC and CO still very low, 1 ppm and 39 ppm, respectively. The low values for NO_x that were below the 200 ppm goal verified the design requirement for a reducing atmosphere in the lower portion of the bed, with the equivalence ratio greater than 1, during this first series of tests. The individual tests were planned to obtain data that brought out the fluidized bed characteristics and were not just for obtaining the minimum pollution goals. The interdependence of the different operating parameters was determined.

AEHA performed the emission monitoring for the last two series of incineration tests. Both TNT and Composition B were burned during these tests at concentrations and rates similar to the previous runs. The fluidized bed temperature was varied (from 1450°F to 1950°F (788°C - 1066°C)), as was the primary and secondary air and fuel. The results (tables 9 & 10) again demonstrated that NO_x emissions from the incinerator could meet the 200 ppm goal for slurries containing up to 22% explosives in water. Furthermore, the tests did prove that as the equivalence ratio (Φ) and fuel increase, the NO_x decreases.

Table 8. Selected data from Scott Environmental Technology, Inc.
(with & without catalyst)

Run no.	% INT	Disposal rate lb/hr	Disposal rate kg/hr	Primary air ft ³ /min	Primary air m ³ /sec	Secondary air ft ³ /min	Secondary air m ³ /sec	In-bed fuel gal/min	In-bed fuel m ³ /sec	Equivalence ratio $\frac{\Phi_1}{\Phi_2}$	NO _x ppm	HC ppm	CO ppm
1	0	0	-	2400	1.10	0	0	0.70	4.41	0.46	18	-	28
2	0	0	-	1100	0.50	1000	0.47	0.70	4.41	1.01	16	-	28
5	15	177	80	2400	1.10	0	0	0.73	4.60	0.48	500	<1	9
7	15	177	80	1900	0.90	500	0.24	0.75	4.70	0.63	470	<1	69
11	20	233	106	1900	0.90	500	0.24	0.80	5.00	0.66	280	<1	32
c a t a l y s t - a d d e d													
15	15	177	80	1400	0.66	500	0.24	0.75	4.70	0.85	570	<1	17
16a	15	177	80	800	0.38	1000	0.47	0.75	4.70	1.48	20	<1	<1
16b	15	177	80	800	0.38	1000	0.47	0.75	4.70	1.48	200	<1	52
17	15	177	80	650	0.30	1000	0.47	0.71	4.50	1.72	16	<1	1
19	20	261	118	650	0.30	1000	0.47	0.71	4.50	1.73	300	<1	11
20	20	261	118	1000	0.47	550	0.26	0.71	4.50	1.12	240	<1	6
21	20	261	118	700	0.33	550	0.26	0.71	4.50	1.61	320	<1	6
24	25	311	141	900	0.42	1000	0.47	0.76	4.80	1.34	490	<1	55
25	25	311	141	700	0.33	1000	0.47	0.76	4.80	1.72	340	<1	64
26	25	320	145	600	0.28	1000	0.47	0.76	4.80	2.01	350	<1	55

Table 9. Selected Data from USAEHA-First Visit
(with catalyst)

Run no.	% Explosive*	Disposal rate lb/hr	kg/hr	Primary air ft ³ /min	m ³ /sec	Secondary air ft ³ /min	m ³ /sec	In-bed fuel gal/min	m ³ /sec	Equivalence ratio $\frac{\phi_1}{\phi_2}$	NO _x ppm	HC ppm	CO ppm
6	15 B	177	80	800	0.38	1000	0.47	0.98	6.2	1.94	360		0
9	15 B	240	109	400	0.19	1000	0.47	0.80	5.0	3.16	288		0
10	15 B	240	109	500	0.24	1000	0.47	0.90	5.7	2.85	215		0
11	15 B	240	109	500	0.24	1000	0.47	0.85	5.4	2.69	187		0
13	15 B	240	109	500	0.24	1000	0.47	1.05	6.6	3.32	185		0
14	5 B	77	35	500	0.24	1000	0.47	1.15	7.2	3.64	173		0
16	15 T	240	109	500	0.24	1000	0.47	1.05	6.6	3.32	295		0
17	5 T	77	77	500	0.24	1000	0.47	0.88	5.5	2.78	280		0

* B - Comp B
T - TNT

Table 10. Selected Data from USAEHA-Second Visit
(with catalyst)

Run no.	Comp B	lb/hr	rate kg/hr	Primary air ft ³ /min	m ³ /sec	Secondary air ft ³ /min	m ³ /sec	In-bed fuel gal/min	m ³ /sec	Equivalence ratio $\frac{\phi_1}{\phi_2}$	NO _x ppm	HC ppm	CO ppm
5	22	361	164	1100	0.52	1000	0.47	1.12	7.1	1.61	184	4	0
6	22	361	164	1200	0.56	1000	0.47	1.08	6.8	1.42	294	6	0
7	15-20*	250*	113	700	0.33	1000	0.47	0.85	5.4	1.92	192	106	0

*Approximate value - Unable to get sample of slurry to check density, due to feed system problem

In addition, AEHA performed special sampling and analyses to insure that no toxic emissions were generated during operation of the incinerator. It was determined that both nickel and aluminum emissions were significantly below toxic levels. The testing also proved that no toxic nickel compounds were formed during the incineration process. The test program showed that the fluidized bed is a viable technique for the efficient disposal of P&E waste with minimum pollution.

In support of the fluidized bed development program, various safety analyses were performed on the different incinerator designs and supporting systems. Two of the major studies were (1) the evaluation of the specifications for the prototype design by Allegany Ballistics Laboratory (ABL) (ref. 3) and (2) detonation propagation tests of P&E slurries and the pilot testing of the slurry injection system by Hazards Research Corp. (HRC) (ref. 4-6). The ABL recommendations led to modifications in the design of slurry and fuel feed systems and to extra safety interlocks. The HRC analysis and detonation tests verified the safe slurry concentration (25%) and operational integrity of the slurry injection system (Appendix C).

As a followup to the successful evaluation of the fluidized bed incinerator for P&E waste, at ARRADCOM, a low cost, 500 lb/hr (227 kg/hr) modular system was designed. This system incorporated all the design criteria mandated for safe, efficient operation as determined by the operation of the pilot unit. However, unlike the ARRADCOM pilot unit, it featured only the instrumentation, controls, and emission monitoring apparatus required to operate efficiently. This system could be utilized at the various GOCO plants to safely dispose of their P&E wastes, while conforming to current and anticipated emission standards. A survey was conducted of the major fluidized bed companies, using specifications for the major incinerator components (chamber, blower, cyclone, grid, instrumentation, and controls). The cost estimates received for the above system ranged from \$210,000 to \$505,000 (August 1977). A reasonable cost figure for the above system, including design, fabrication and preliminary checkout, on-site supervision during erection, operator training, and start-up assistance, is \$400,000. An optional heat exchanger for preheating the fluidizing air would be approximately \$75,000 additional (Appendix D).

CONCLUSIONS

Hazards analysis of the incinerator design, detonation propagation tests of typical P&E slurries, grinding and slurry techniques, and pilot and prototype testing prove that incineration is a reliable, safe alternative to open burning for the disposal of waste P&E. This was verified at ARRADCOM by both the vertical induced draft and the

fluidized bed incinerator programs, as well as the rotary kiln development at Radford Army Ammunition Plant.

Of the various techniques studied, the fluidized bed incinerator promises to be the most suitable system, especially in areas where air pollution standards are stringent. It is a compact system, and, by using a catalyst, can conform to current and anticipated standards for NO_x , HC, CO, and SO_2 , without the use of pollution abatement equipment.

The major accomplishments of the project are:

1. Verified design parameters for 500 lb/hr (227 kg/hr) disposal rate (e.g., fuel flow, fluidizing and secondary air, equivalence ratio (Φ), grid design).
2. Verified use of nickel oxide catalyst to reduce NO_x emissions.
3. Verified that the use of alternate fuels does not adversely affect emissions or poison the catalyst (Appendix E).
4. Demonstrated very low (almost zero) HC, CO, and SO_2 emissions for all feed rate/concentrations of explosive slurry. Low HC and CO also verified high combustion efficiency.
5. Data yielding extremely low carbon particulate emissions verified low ash residue. The particulates collected were almost entirely alumina, and, although the emissions were above target levels, they could easily be controlled by using another cyclone.
6. Demonstrated that nickel and aluminum emissions are significantly below minimum toxicity limits.
7. Demonstrated that NO_x emissions can meet the 200 ppm goal for 22% concentration of explosives in waster, provided the fuel-air ratio is properly controlled (table 9, runs 5, 6, 7). From table 9, it can be seen that as Φ increases, NO_x decreases. This shows that it should be possible to design a fluidized bed incinerator to meet the 200 ppm goal.

The efforts at ARRADCOM and Radford AAP fully demonstrated the feasibility of using P&E/water slurries for the incinerator feed. This included the grinding, mixing, pumping, and metering of P&E slurries. Detonation propagation tests proved that generally a 30% concentration would not support propagation. A P&E concentration of 25% maximum was used to further insure safety and to aid slurry pumping.

Close examination of all the data (Appendix F) leads to the conclusion that there is an optimum equivalence ratio (Φ_1) for each explosive and explosive slurry concentration, i.e., equivalence ratio is dependent on type and quantity of P&E material burned. Therefore, it would be necessary to run a short series of tests to determine the best operating parameters for the individual plant's wastes.

The prototype system was developed to the extent attainable with respect to the available equipment and program restraints. However, sufficient data was generated to provide criteria for the design of a safe, reliable, low cost system. This system is compact and can provide the process controls necessary to achieve optimum conditions for P&E disposal with minimum pollution and at a reasonable cost.

RECOMMENDATIONS

It is recommended that:

1. The fluidized bed incinerator be considered for installation at facilities where air pollution is a major constraint on the incinerator design.
2. A short series of tests be performed to determine the best operating parameters for the individual plants' wastes.
3. Water-veying, with or without size reduction, be considered for any incinerator feed system and/or material transport.
4. Although sufficient data was acquired to verify design concepts and establish design data, it would be advantageous to perform a preliminary test program on the low cost system components.

REFERENCES

1. C.D. Kalfadelis, "Development of a Fluidized Bed Incinerator for Explosives and Propellants," Esso research & Engineering Co., Linden, NJ, Oct 73.
2. Vincent T. Ciccone, Alan P. Graves, Joseph S. Santos, and Robert Scola, "Economic Analysis of Rotary Kiln versus Fluidized Bed P&E Incinerators," Technical Report ARLCD-TR-78033, ARRADCOM, Dover, NJ, Sep 78.

3. R.A. Knudsen, "Hazard Analysis of Pollution Abatement Techniques," Contractor Report A0262-520-03-007, Picatinny Arsenal, Dover, NJ, Jun 74.
4. George Petino, et al, "Detonation Propagation Tests on Aqueous Slurries of RDX, HMX, M-1 and Nitrocellulose," Contractor Report ARLCD-CR-77002, ARRADCOM, Dover, NJ, Apr 77.
5. George Petino, et al, "Detonation Propagation Tests on Aqueous Slurries of TNT, Composition B, M-9 and M-10, TR-4584, Picatinny Arsenal, Dover, NJ, Nov 73.
6. George Petino, et al, "Flow Characteristics of Explosive Slurry Injector System," Contractor Report ARLCD-CR-77004, ARRADCOM, Dover, NJ, Apr 77.

APPENDIX A: ALTERNATE SOLUTIONS

The vertical induced draft, rotary kiln, SITPA I and II, wet-air oxidation, and fluidized bed incinerator systems are all designed to handle the problem of waste propellants and explosives (P&E) disposal, and each attacks the problem in a different manner. Different incinerators could be selected depending on the various emission regulations for the specific site. The more sophisticated P&E incinerators have been designed to meet air pollution standards (existing or forecasted) and provide adequate air and turbulence for proper combustion. Emission control equipment is included on some of these incinerators to further reduce the amount of CO, HC, and NO_x released. Because of the quantity of NO_x emissions, state and federal environmental agencies are identifying, assessing, and promoting the development of cost-effective commercially viable methods for NO_x control from both existing and new stationary combustion sources. It is anticipated that controls will be required on all P&E waste incinerators and will take the form of lowering NO_x formation during combustion, post-combustion removal of NO_x from the combustion products, or catalytic interaction within the process itself.

In addition, the majority of the incinerator systems require waste particle sizes of approximately 1/8 in. (0.0032 in.) to obtain good combustion either in the dry state or for injection of an aqueous slurry. The P&E wastes are in the form of riser scrap, shell washout, process by-products, and unacceptable end items. A large portion of this waste must be reduced in size prior to disposal. The current methods of reducing these wastes are by rotary knife grinders, cone crushers, attrition mills and ball mills. All of these methods use a water medium of approximately 10 pounds (4.54 kg) of water for each pound of P&E waste in order to cool the grinding area, prevent the P&E waste from heating up, and help reduce the possibility of spark formation. Water also helps make plastic-type propellant more rigid and, therefore, easier to grind.

Vertical Draft Incinerator—The forerunner of the P&E waste incinerator program was the vertical draft incinerator (fig. A-1). This incinerator was constructed in the 1950s at Picatinny Arsenal to dispose of red water and other contaminated liquid wastes. The unit was a cylindrical steel furnace lined with firebrick. It was modified to dispose of waste P&E in aqueous slurries of 25% by weight. Feasibility and safety requirements, particle size reduction, suspension, injection, combustion, and baseline gaseous emissions data were established and evaluated. The process consisted of heating

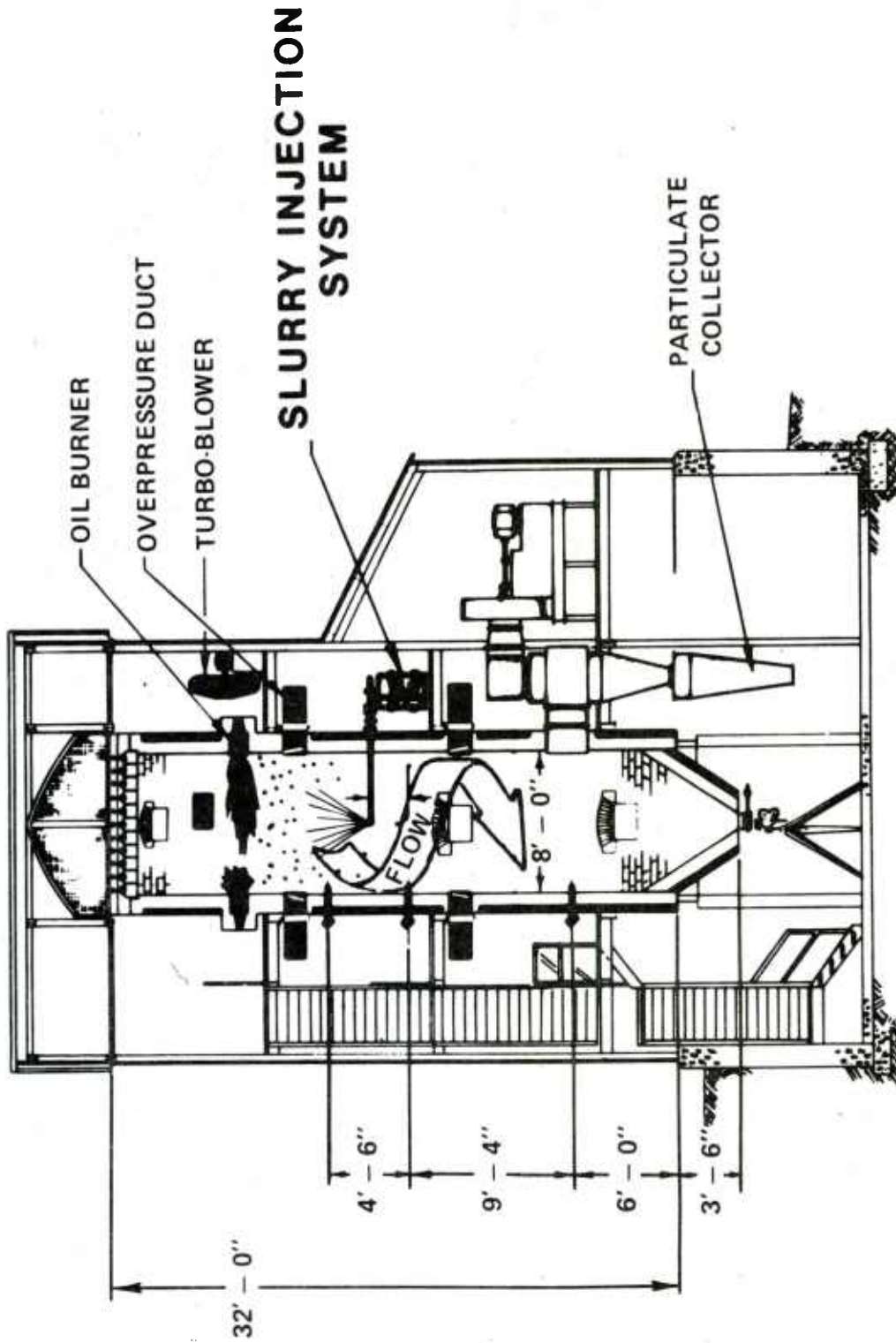

FIGURE A-1. PICATINNY ARSENAL-VERTICAL INDUCED DRAFT INCINERATOR.

the chamber by means of three oil-fired burners to a temperature of 1600-1800°F (871-982°C), and then injecting the slurry up toward the flame. The downward draft provided by the induced draft enhanced the combustion process by providing combustion air and circulated the gaseous products within the combustion chamber. The gaseous products were then passed through a cyclone separator and vented to the atmosphere through a 125 ft (38.1 m) stack. This type of incinerator is presently outdated due to its inefficient operation and poor emission control.

Rotary Kiln—The rotary kiln incinerator (fig. A-2) consists of a refractory lined cylinder inclined to the horizontal at an angle of between 2-5 degrees and rotating at a slow speed (1-5 rpm). Often both the speed of rotation and the inclination of the furnace are variable so that the flow of material through the cylinder and the retention time for combustion can be controlled. Afterburning facilities can be incorporated in a separate auxiliary chamber, and the equipment generally lends itself to flexible plant layout. By using chamber rotation, these furnaces offer the advantages of a gentle and continuous mixing of the P&E slurry, but capital and maintenance costs are high. These costs are derived from the mechanical design requirements of both rigidity of the cylinder and close tolerances for the roller path drive, as well as the high-temperature seals between fixed and moving parts. Another major disadvantage is the adverse effect of the ambient explosive slurry contacting the heated refractory lining (871-982°C) during injection and the detrimental effect on the refractory of cooling and reheating the chamber during shutdown.

This system required the use of a cooler and scrubber to reduce the gaseous and particulate emissions and exhaust gas temperature prior to passing through the exhaust fan and stack. The rotary kiln was proven to be a safe, reliable, and smoke-free incineration technique. It has been proposed that the rotary kiln system, without the scrubber, be used at plants that require a P&E incinerator that abates only the particulate emissions. This would reduce the initial capital and operating costs and still have the flexibility to add the scrubber at a later date.

SITPA I—The Simplified Incineration Technique for Pollution Abatement (SITPA) is an incinerator designed to eliminate the complexity of the other systems described (fig A-3). The SITPA process involves manually placing P&E waste on a concrete pad or covered ditch and remotely igniting it. The pad has a hood which accepts the combustion gases and draws them into a duct by means of induction fans. The duct is connected to a baghouse where particulate matter is removed from the exhaust gases. The gases pass through the fan and then out the stack. It is possible to hook up several pads to a single baghouse by ducts and a manifold.

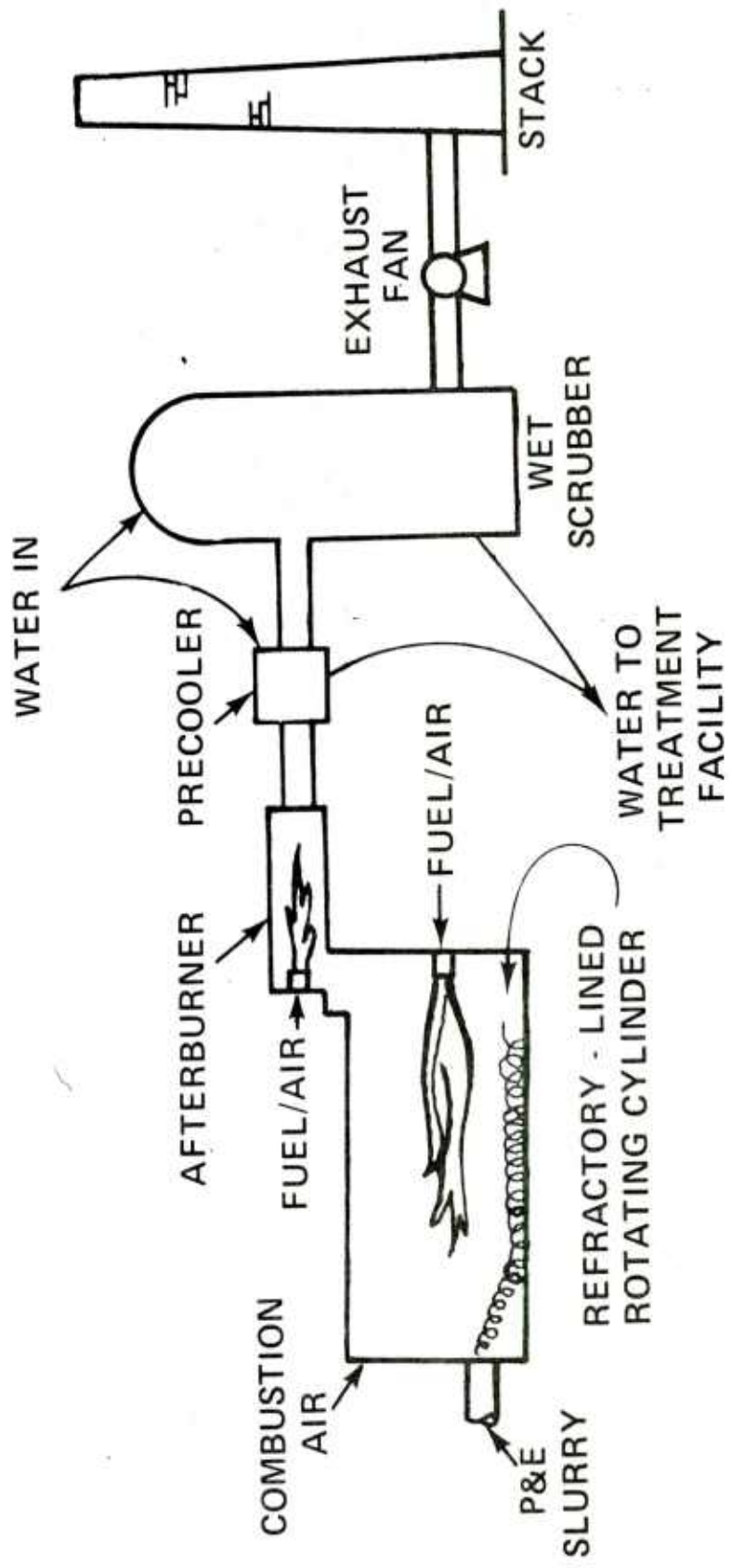

FIGURE A-2. ROTARY KILN INCINERATOR

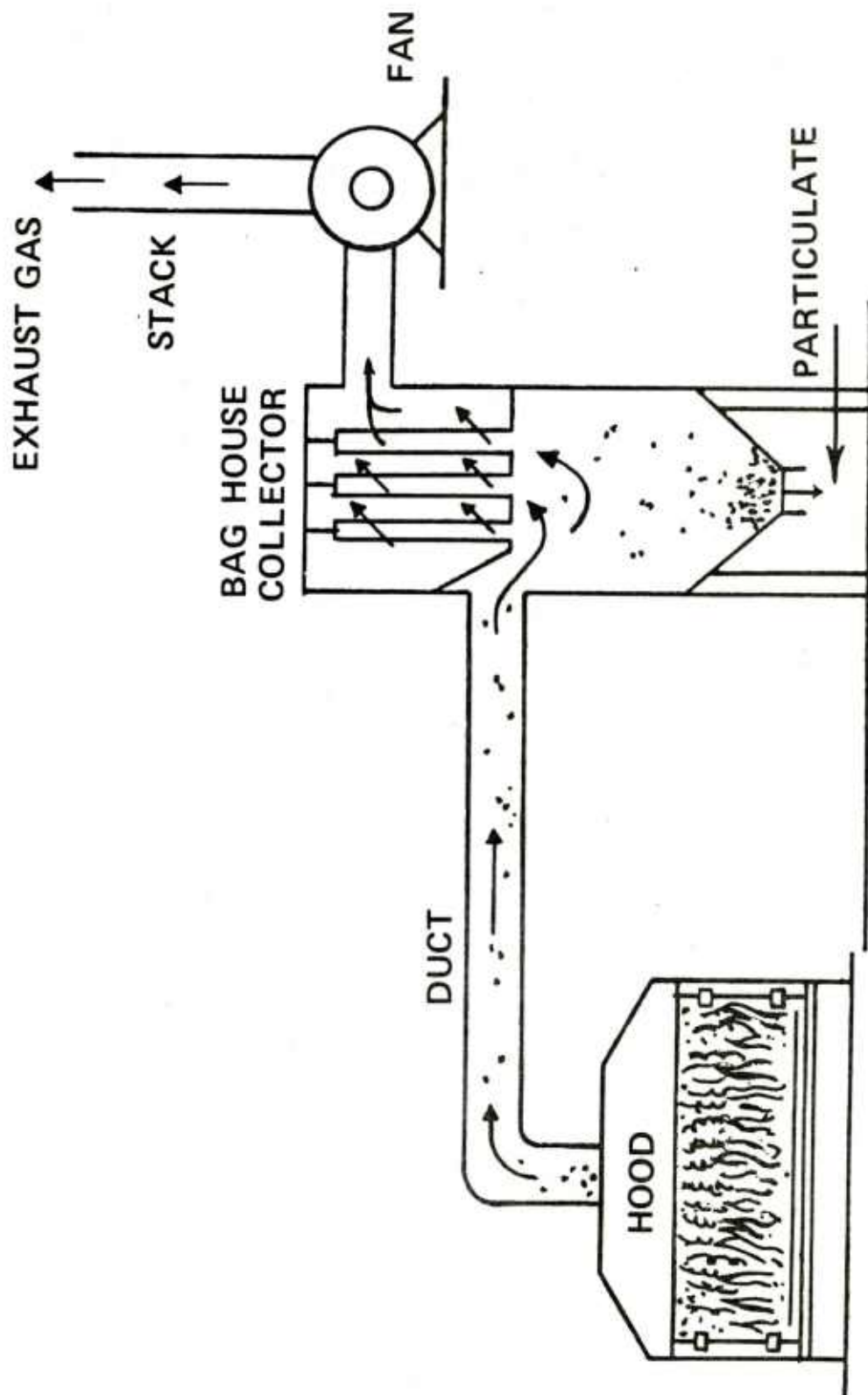

FIGURE A-3. SITPA I SYSTEM.

The system, while simple, does not provide either the process control, pollution abatement, or safety features inherent in the other systems described.

SITPA II—The SITPA II (fig. A-4) process is a specially designed, unlined, rotary kiln incinerator in which the waste P&E is fed into the combustion chamber in cans containing set amounts of the waste P&E placed at intervals on a conveyor belt. The waste P&E is burned in the combustion chamber heated by oil burners. The combustion gases are removed from the chamber by an induction fan, diluted with ambient air to reduce the temperature, and then passed through a baghouse to remove particulates. This system could be operated in the semi-continuous mode for long periods of time and has the capability for use as a demil facility (its original design) for small arms and small explosive items.

The SITPA II has minimum process controls, no NO_x abatement (a scrubber would be required), requires dilution of the exhaust gases to protect the baghouse, and has a manual feed system. The feed system is run manually and is a potential safety hazard for the operators.

Wet Air Oxidation—This process is fundamentally the aqueous oxidation of waste P&E in a high pressure vessel (autoclave) (fig. A-5). The vessel and the water inside are initially heated by steam and compressed air to achieve 550°F (288°C) and 400 psi (2.76×10^6 Pa). When these conditions are reached, the steam is shut off and the feed started. The ground waste P&E is fed in a continuous aqueous slurry along with compressed air. The P&E wastes are oxidized and the energy in the waste is sufficient to sustain the reaction without any supplemental heat inputs. The vessel is operated typically at pressures in the range of 600-2200 psi (4.14×10^6 - 15.2×10^6 Pa), and at temperatures between 400 - 600°F (204 - 316°C). The oxidation products, consisting of gaseous and liquid products, nitrogen from the compressed air, and a minor quantity of ash, are cooled by the feed stream in a heat exchanger and separated into gaseous and liquid streams. The gaseous stream is treated, using an afterburner, to destroy CO and residual hydrocarbons, and a wet scrubber to reduce NO_x prior to discharge to the atmosphere. The liquid phase is processed to neutralize acidity and remove metallic salts. The purified water is recycled to the slurry preparation stage.

Fluidized Bed Incinerator—The fluidized bed incinerator (fig. A-6) uses aluminum oxide (alumina) for the bed material. The operation of the fluidized bed involves the forcing of air, which can be controlled to a desired rate, through the distributor plate. At low rates, the bed remains in its original "settled" state, with the

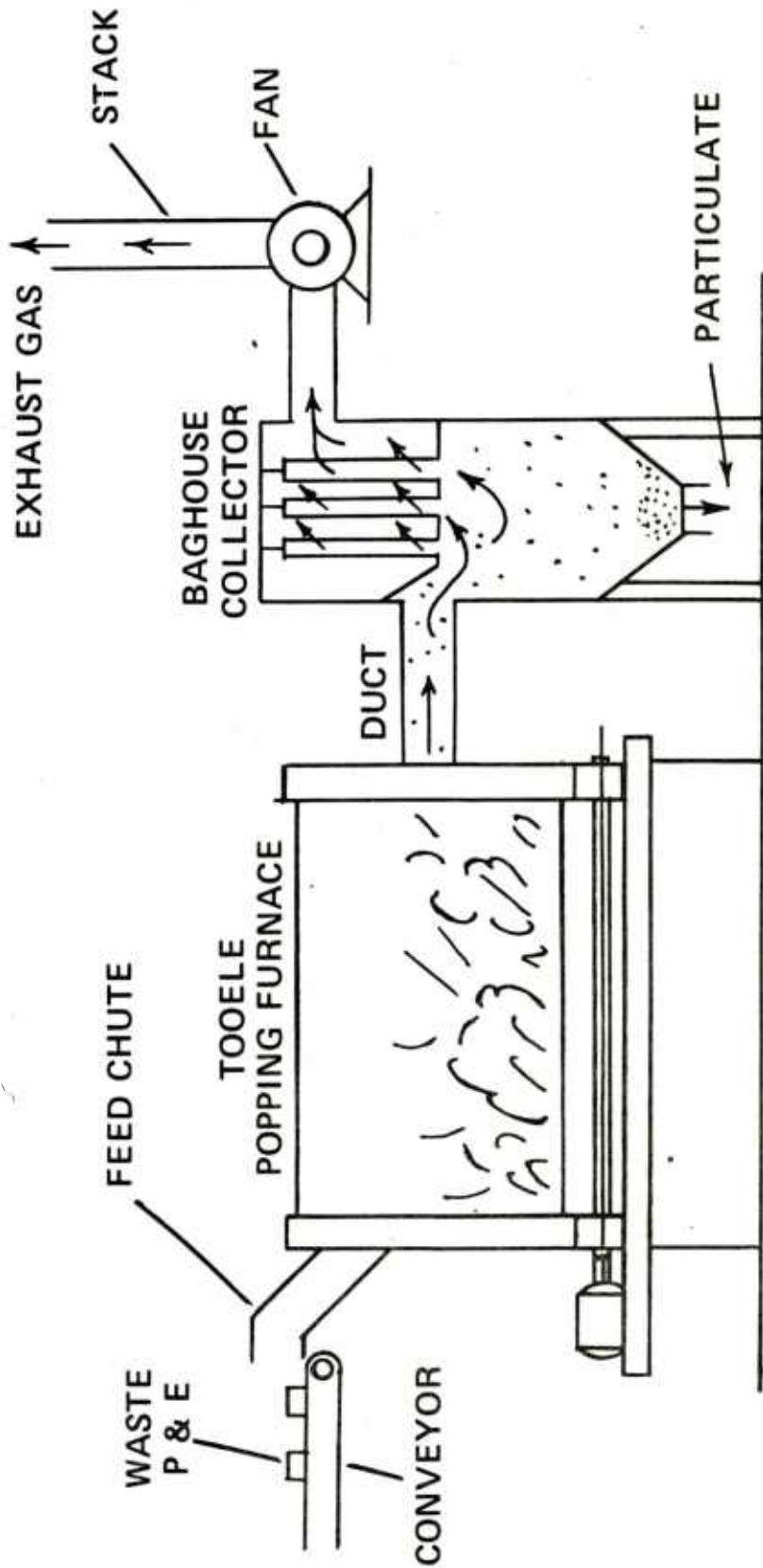

FIGURE A-4. SITPA II SYSTEM.

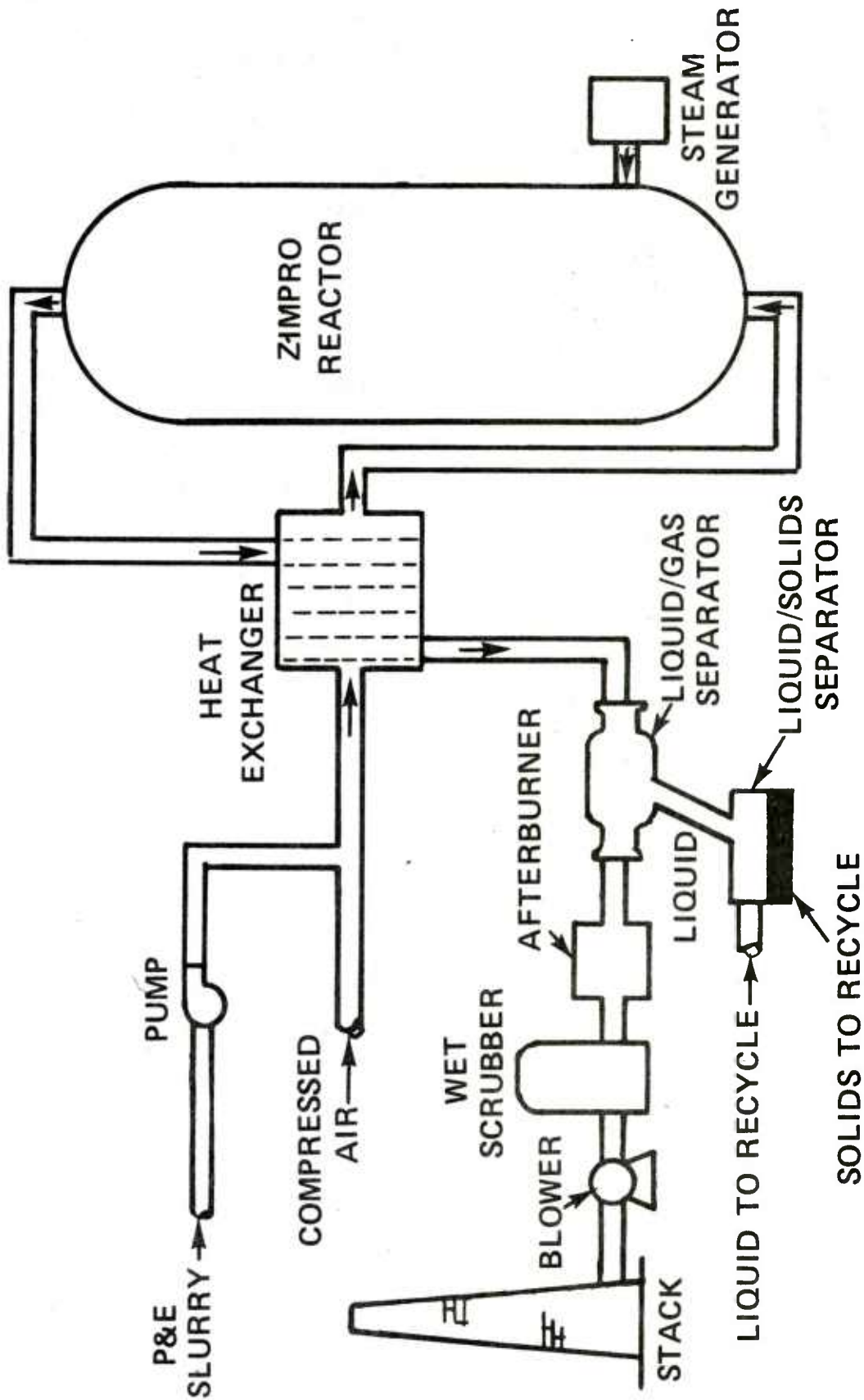

FIGURE A-5. WET-AIR OXIDATION (ZIMPRO) PROCESS.

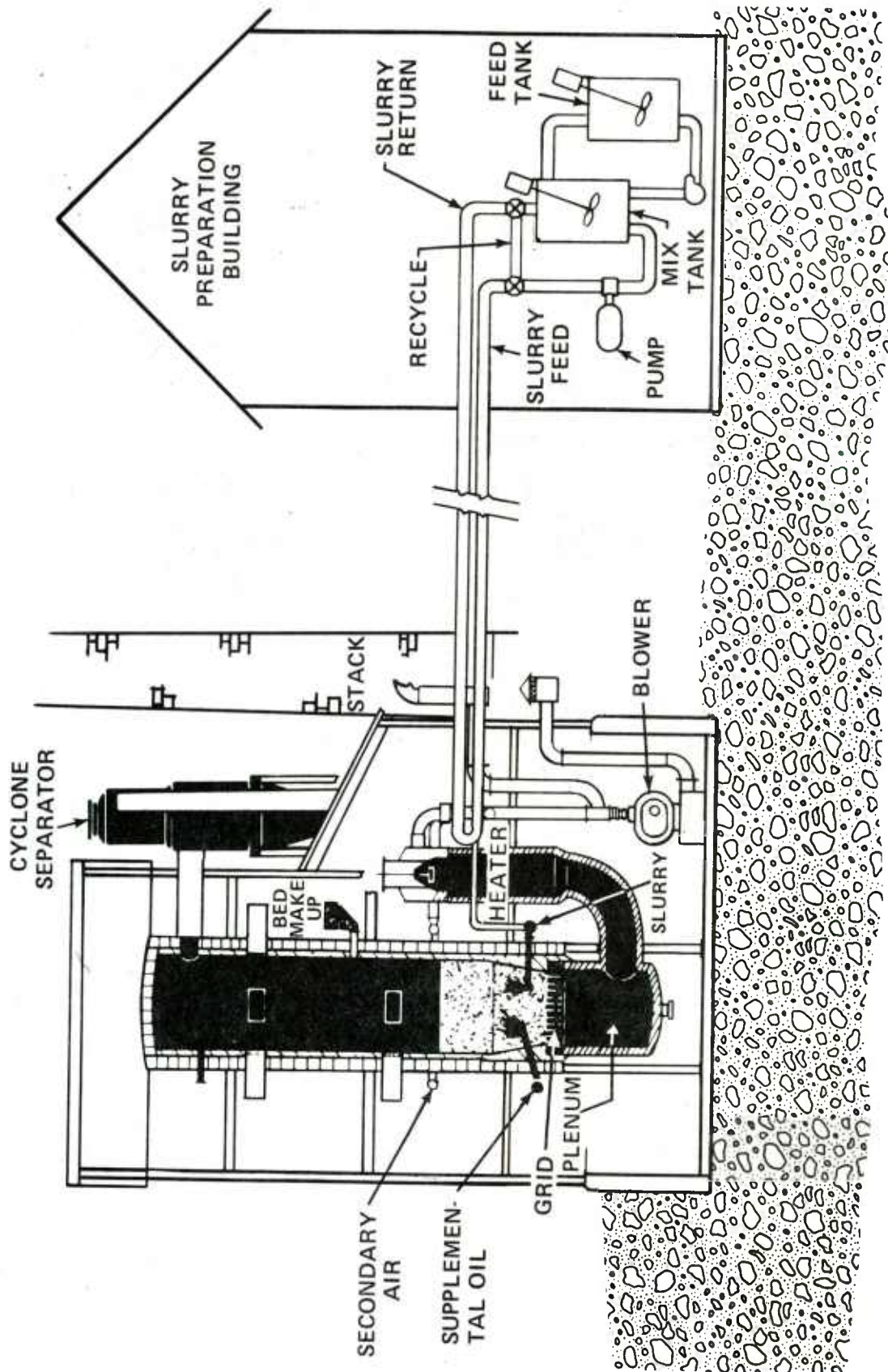

FIGURE A-6. FLUIDIZED BED INCINERATOR.

pressure drop across the bed increasing with the flow rate until it is equal to the downward force exerted by the bed material resting on the plate. The bed begins to expand at this point, which is called "incipient buoyancy," allowing more gas to pass through the bed at the same pressure drop. As the air flowing through the grid is further increased and approaches that required for bubble formation, the bed approaches "incipient fluidization" and has all the properties of a fluid.

The advantages of this system are: (1) the enriched oxygen of the bed coupled with the mixing action of the alumina and waste ensures complete combustion, thereby minimizing carbon monoxide and hydrocarbon emissions; and (2) the uniform temperature of the bed, plus the use of a nickel catalyst, limits the formation of nitrogen oxides. The fluidized bed has provisions for the injection of supplemental oil and auxiliary air into the bed. Supplemental oil is introduced directly into the bed to maintain the bed temperature and to help create the reducing atmosphere in the lower part of the bed to reduce the NO_x emissions.

Combustion is a chemical reaction that requires the contacting of a fuel with oxygen at a temperature above the kindling temperature. Both a high degree of turbulence and adequate oxygen are required to attain complete combustion. Excess air is the amount of air added to a combustion process beyond that required stoichiometrically by the chemical reaction. The auxiliary air nozzles provide excess air to the bed to help reduce noxious gaseous emissions. The bed itself maintains a reducing atmosphere, while the auxiliary air helps provide an oxidizing atmosphere in the upper portion of the bed. The nitrogen present in the combustion reactions can come from both the air and the fuel. Some of the nitrogen is oxidized, with the nitric oxides (NO_x) being an undesirable product of combustion. The NO_x formed is a function of the combustion temperature, reaction rate, residence time, nitrogen and oxygen concentrations, and quench rate. As excess air and turbulence in the fluidized bed chamber are increased, more products of complete combustion are obtained. Gaseous pollution products are further reduced by the presence of the nickel oxide catalyst in the bed, which not only enhances the combustion of the gaseous fuels (CO, HC) that are present, but also drastically reduces the NO_x concentration in the exhaust gases.

The fluidized bed incinerator is the only system that promises to be able to conform to current and anticipated regulations for P&E incinerators. Its characteristics of high combustion efficiency, low gaseous and particulate emissions, high heat sink capacity, low operating cost, and inherent safety features are the basis for selection of the fluidized bed for further development.

APPENDIX B. EQUIPMENT

A brief description will be given for each of the major components/subsystems in the fluidized bed design.

Preheater

The preheater's function is to heat the incoming air during periods of startup. It provides 1100°F (593°C) air to the plenum chamber, which passes through the grid and into the bed. When the bed reaches 700°F (371°C), the in-bed supplemental oil feed is activated, and the preheater is shut off.

The preheater unit is fired with No. 2 distillate fuel oil. Ignition is accomplished with an explosion-proof, propane gas, pilot light system. The fuel oil is air atomized, and operating pressures of both oil and air are critical for optimum performance. The unit is capable of raising the temperature of the incoming air (5000 SCFM max or 2.36 m³/sec) from approximately 140°F (60°C) to 1100°F (593°C) with a maximum firing rate of 7.5 x 10⁶ BTU/hr (2.2 x 10⁶ W).

The preheater is used only for the startup periods, due to the required slow heatup of the refractory in the unit itself, the elbow, and the plenum. Strict adherence is required to the operating schedule to prevent damage to the refractory. The ARRADCOM unit requires 400% excess air to prevent overheating of the refractory.

Blower

The blower is a major component of the fluidized bed system. It provides combustion, fluidizing, and secondary air to the process. The blower is sized to accommodate the various pressure drops in the system (table B-1). It must also be capable of providing the necessary air for the preheater to prevent excessive heat buildup in that unit.

The unit specified for the ARRADCOM incinerator was explosion-proof in full conformance with NEC-1971 for Class I - Groups C, D, Class II - Groups E, F, G areas. The blower was designed to provide 5,000 SCFM at 8 psig discharge pressure (2.36 m³/sec at 55,200 Pa), and supplied with intake and exhaust filters/mufflers.

Cooling Tower

The cooling tower is required to provide the water used for the water-cooled slurry and oil injection nozzles and chamber pressure

Table B-1. Design parameters

Blower capacity

System pressure drops

Preheater	0.75 psig	(5.2 x 10 ³ Pa)
Grid	1.50	(10.3 x 10 ³ Pa)
Bed	3.50	(24.13 x 10 ³ Pa)
Cyclone	1.50	(10.3 x 10 ³ Pa)
Total	<u>7.25</u> psig	(50 x 10 ³ Pa)

Required air flow for velocity of 6 ft/sec (1.83 m/sec) in chamber
 6 ft/sec x 60 sec/min x 42.2 ft² = 15,192 ft³/min at 1650°F & 1.5 psig
 (1.83 m/sec) x 3.92 m² = 7.2 m³/sec at 899°C & 10.3 x 10³ Pa)
 Correcting for temperature and pressure this relates at standard
 conditions to 4400 standard ft³/min (124.6 m³/sec).
 The rated capacity of the blower is 5000 standard ft³/min (141.5 m³/sec)
 at an output pressure of 8 psig (55.2 x 10³ Pa).

transducers. These items must be maintained at 80-90°F (27-32°C). The design of the unit is proportional to the number of injection guns and pressure taps.

Grid

In the design of the grid, the pressure drop should be equal to 10-30% of the bed pressure drop, in order to insure that all the holes are blowing equally. Air can be injected through the grid in several manners. The simplest is the "thru put" grid, which is basically a series of holes in the grid ($\Delta P = 30\%$).

Another is the bubble cap ($\Delta P = 10\%$). The bubble cap (fig. B-1) design prevents the bed material from flowing into the plenum and also can give better dispersion of the air passing through the grid. The bubble caps should have no flat horizontal surfaces, which would promote the merging of bubbles at the grid nor any surfaces nearby which would be effected by the penetration zone of the grid. These surfaces would promote the attrition of the bed material and catalyst. The pressure drop of the grid can be calculated by dividing the total air flow through the grid (ft^3/min or m^3/s) by the total area of the holes.

$$\text{grid } \Delta P = \frac{\text{ft}^3/\text{min or m}^3/\text{s}(\delta)}{\text{total area of holes}}$$

Note: Assume all holes blowing equally.

The function of the grid may be summarized as follows:

- a. It must induce fluidization as opposed to spouting
- b. Complete fluidization must be induced on startup, and the bed should be maintained in constant motion during operation.
- c. The grid must be capable of operating for long periods without any appreciable increase in pressure drop due to solids deposit.
- d. It is sometimes necessary to prevent the bed material from running back into the plenum.

Chamber (includes plenum and grid)

The combustion chamber is a major assembly of the incinerator system and consists of the plenum, grid, and chamber.

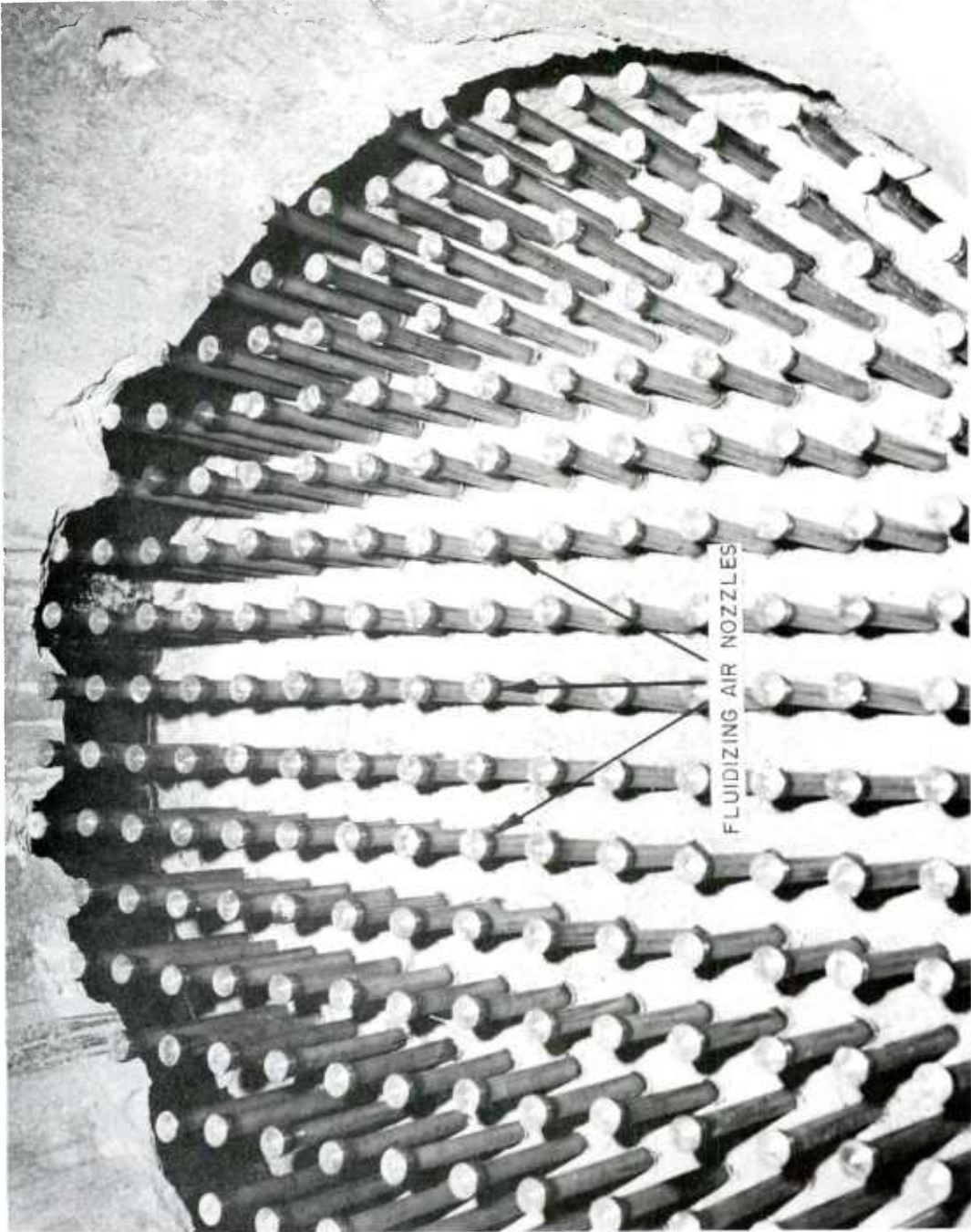

Figure B-1. Top view of incinerator grid.

The plenum is a refractory-lined staging area for the fluidizing (primary) air and is of sufficient volume to allow the incoming air to be spread evenly across the bottom of the grid. In addition, when the preheater is on, the volume of the plenum aids in the mixing of the heated air to give it an even temperature distribution before entering the chamber through the grid.

The grid is a conical plate with 221 bubble caps that provide even distribution of the primary air. One of the most important aspects of the fluidized bed incinerator design is the assurance that the fluidizing air enters the bed reasonable uniformly distributed over the bed's cross-section. This assists in keeping the bed relatively homogeneous; periodically, there will be a preponderance of voids, bubbles, above one section of the grid and, within a second or two, above another section, etc. However, proper grid design reduces the chances of a non-homogenous bed.

The chamber itself is a cylindrical steel shell 8 feet (2.44 m) in diameter and 30 feet (9.14 m) high with an 18 inch (0.46 m) refractory insulation lining. It has provisions for injecting supplemental (in-bed) oil to add heat to the bed, secondary air to aid combustion, and the explosive slurry for disposal.

The supplemental oil can be injected through any combination of six oil nozzles, each having a maximum capability of 0.65 gal/min ($4.1 \times 10^{-5} \text{ m}^3/\text{sec}$). The utilization of the in-bed oil is the most efficient method of maintaining heat in the bed while operating, because the turbulence in the bed is sufficient to provide ample distribution of the heat throughout the bed.

Secondary air is provided through six ports, in the upper portion of the bed, that are operated in pairs. The secondary air is used as an aid to combustion and for emissions control in conjunction with the nickel oxide catalyst. The nickel oxide requires, for maximum pollutant reduction, a reducing atmosphere in the lower portion of the bed and an oxidizing atmosphere in the upper portion (provided by the secondary air).

The six slurry injection nozzles (fig. B-2) are alternated with the oil nozzles (fig. B-3) around the chamber's periphery (fig. B-4). The six nozzles were originally designed to be operated in pairs to provide additional injection capability, and in the case of a plugged nozzle, the capability to switch to another set. However, it was decided that the required flows could be accomplished more safely and efficiently by using one modified slurry gun with flow monitoring instrumentation.

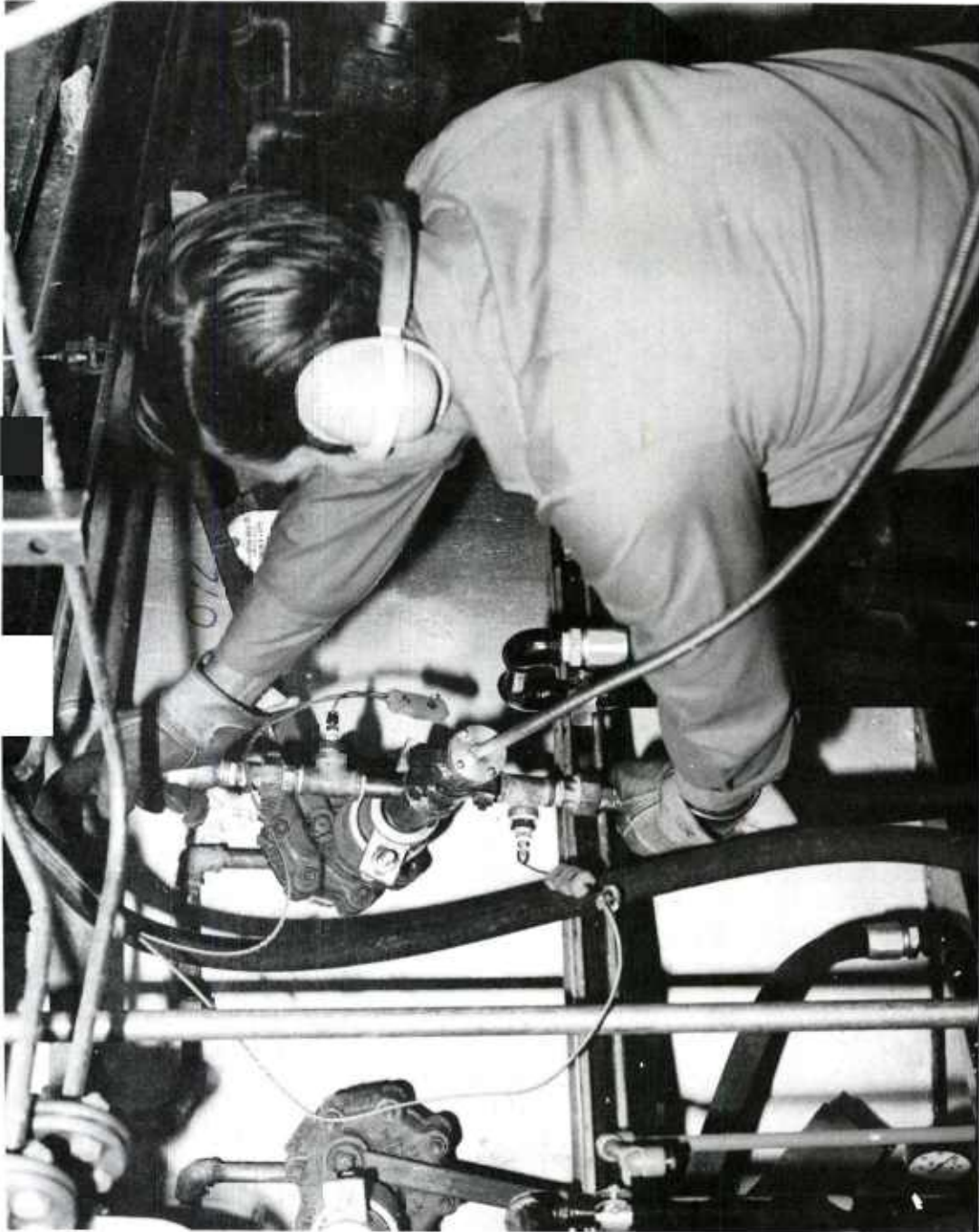

Figure B-2. Inserting slurry gun into the incinerator.

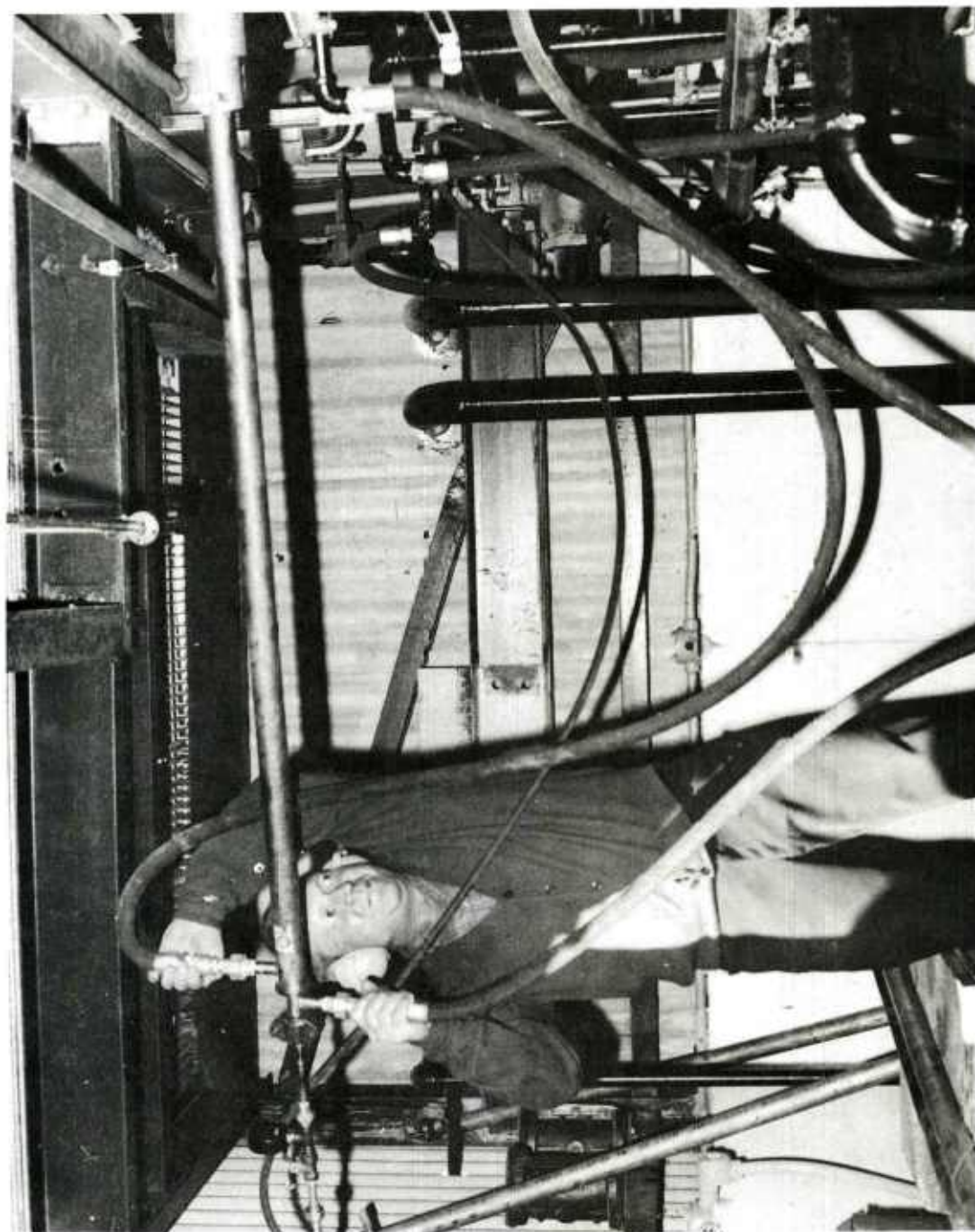

Figure B-3. Inserting oil gun into the incinerator.

FLUIDIZED BED PILOT INCINERATOR

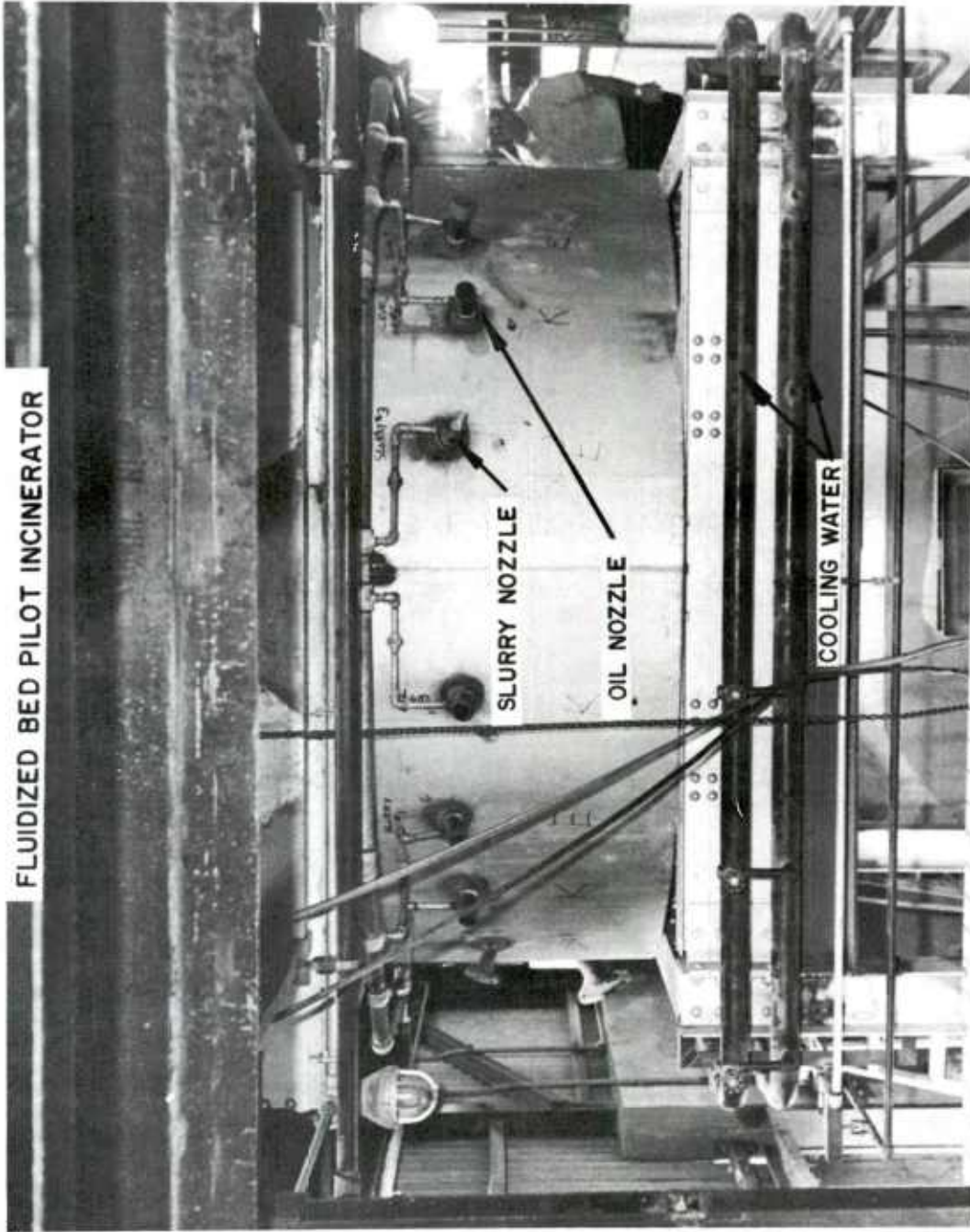

Figure B-4. Incinerator injection level showing positions of slurry and oil ports.

The design of the chamber diameter is set by the volumetric flow rate. The design of the chamber height must take into consideration two factors: first, the determination of the expanded bed height, which is normally 2 to 3 times the settled bed height and second, the transport disengaging height (TDH) or freeboard, this is the vertical distance required until the particle velocity is stabilized. At this point, only those particles with terminal velocities less than the superficial gas velocity will be carried on to the cyclone. This height (TDH) can be obtained from graphs, when the chamber diameter and bubble gas flow (ft³/sec or m³/sec) are known.

Cyclone

The cyclone is required for the removal of particulate matter entrained in the exhaust gases leaving the incinerator chamber. The cylindrical upper part is closed at the top except for a central orifice (exhaust duct). The particulate matter enters the cylindrical shell tangentially, causing it to swirl vigorously. The particles are thrown against the walls by centrifugal force and the unladen gases pass up and out through the exhaust duct. The particles fall down the sides, converge in the funnel, and pour out the bottom spout (dipleg). The dipleg on the ARRADCOM cyclone is provided with a dump-gate valve for removal of this material. Depending on the coarse/fines ratio in the bed, it may be required to reload this material in the bed. In many applications, the dipleg is connected directly to the chamber to provide a continuous balance of fines when those provided by attrition cannot compensate for those lost through elutriation.

In order to design and size a cyclone, knowledge of the particles' shape factor is required to achieve maximum effectiveness. The ARRADCOM cyclone has the capability of handling inlet air, at approximately 15,000 ft³/min (7.08 m³/sec) 1.5 psig (10,340 Pa) and 1600^oF (871^oC). The unit's efficiency is rated as follows:

<u>Particle size</u>	<u>% efficiency</u>
500 microns	99.99
100 "	99.99
50 "	99.90
30 "	99.0
20 "	97.0
10 "	92.0

The particles collected are primarily alumina fines transported by bubble formation. The unit's interior must be capable of handling this abrasive material. Again, it should be mentioned that, even at the lowest rate of entrainment, enough solids leave the fluidized bed in the exhaust gases to require a solids recovery (cyclone) system.

Exhaust Gas Analysis

During the evaluation of the fluidized bed incinerator, it was desirable to have a continuous monitoring/record of the gaseous emissions. In order to provide this, a continuous monitoring system was designed and installed. The system was primarily the same as that installed on the Radford AAP rotary kiln, but with the addition of particulates monitoring and some process modification. Both systems were designed and fabricated by the Peerless Instrument Company of Elmhurst, New York.

It was specified that non-dispersive (ND), infrared (IR), and ultraviolet (UV) spectrophotometric principles of measurement were to be utilized to simplify maintenance. The full range of incinerator emissions and measurement techniques was specified as follows:

<u>Unit no.</u>	<u>Emission</u>	<u>Method</u>	<u>Mfg</u>	<u>Ranges (ppm)</u>
1	CO	NDIR	Peerless	0-50, 0-250, 0-2500
	HC	NDIR	Peerless	0-50, 0-250, 0-2500
2	CO ₂	NDIR	Peerless	0-10, 0-20%
3	NO	NDIR	Lear Siegler	0-50, 0-250, 0-2500
4	NO ₂	NDUV	Peerless	0-50, 0-250, 0-2500
	SO ₂	NDUV	Peerless	0-50, 0-250, 0-2500
5	Particulates	Opacity	Wager	0-100%

The gas samples were drawn through a filtered probe into a heated line, through a permeation dryer and, finally, into the gas analyzers.

The theory of operation of the analyzers was as follows: each unit contained a light source (either IR or UV) that was reflected through an optical system, which passed a portion of the light beam through a reference cell, and the remaining portion through a cell with the actual sample. The absorption of the light in the sample cell was then compared to that of the reference cell. This reading was then amplified electronically and transmitted to the control room, where it was displayed on both a milliammeter and a chart recorder. Prior to pulling stack gases through the system, a procedure of calibrating the system by the use of standard gases, was performed. This calibration included both the zero and range adjustment for each analyzer.

In the operation of a production type facility, it would not be required to have as many analyzers, due to the low levels of certain gases. For instance, the HC (hydrocarbon) readings were always low (around 10 ppm), and the CO was practically "0".

Due to the delay in delivering this unit, a full evaluation was not performed, and therefore, no determination was made as to its accuracy or dependability.

APPENDIX C. HAZARDS EVALUATION

During the development of the fluidized bed program, various safety analyses were performed on the different subsystems. This was to insure that a safe, reliable process would be developed for the disposal of waste P&E. It originated with the Exxon Corp's small-scale laboratory evaluation (ref. 1) through the Picatinny Arsenal vertical draft incinerator conversion effort, and finally, to the fluidized bed itself. Additional hazard evaluations of the fluidized bed incinerator system were made by the Allegany Ballistics Laboratory (June 1974) (ref. 2). The basis of analysis for this study was the design specifications for the conversion of the vertical draft incinerator to the fluidized bed design. While at the time of the study, this was the most accurate description of the system being installed, it is only a general guide to the system presently installed. The recommendations of ABL were the basis for various modifications that were made in the slurry and fuel (oil and gas) feed systems. In addition, utilization of various safety interlocks (pressure and temperature) reduced the hazards as noted in the ABL study regarding the initiation of these two fuel sources.

The study was also concerned with the initiation modes of a P&E dust cloud and dust layer. Based on the present design of the fluidized bed and its slurry injection system, there is no probability of impingement, thermal, electro-static discharge (ESD) and electrical power discharge modes during normal operation. The P&E wastes are combusted instantaneously upon entering the incinerator chamber and sufficient interlocks are provided to prevent their entry prior to appropriate chamber parameters being attained.

The slurry preparation system utilized for feeding the fluidized bed greatly parallels that used in the Radford AAP rotary kiln (ref. 3). A section of the rotary kiln final report is devoted to this system and states that the system, due to the high water content (minimum 75%), safety interlocks, and water/air flushes, is by its design, inherently safe. In addition, RAAP ran over 100,000 lbs (45,350 kg) of P&E through its feed system and had no explosion or fire.

A test program has been performed to establish the detonation propagation characteristics of aqueous slurries of RDX, HMX, TNT, Comp B, M-1, M-9 and M-10 propellants, and two types of nitrocellulose in 2-in. Sch 40 stainless steel pipes, 24 and 40 in. long (.61 and 1.02 m). The slurry concentrations tested were prepared on a weight percent basis. Table C-1 summarizes the results of this program.

Another study (ref. 6) was conducted to evaluate the most hazardous component in the slurry injection system. This was a 62 ft (18.9 m)

length of 1/4-in. Sch 40 pipe feeding the slurry nozzle. The results of this study were that the system would operate correctly, provided that the slurry velocity was 6 ft/sec (1.83 m/sec) or greater. These velocities were well within the designed capabilities of the system and were constantly monitored.

Table C-1. Summary of detonation propagation test results

<u>Sample material</u>	<u>Slurry type</u>	<u>Concentration in weight percent</u>		<u>Detonation class</u>
		<u>No propagation</u>	<u>Full propagation</u>	
RDX	gelled	20	30	high order
RDX	settled	10	20	high order
HMX	gelled	20	30	high order
HMX	settled	5***	5-10	high order
M-1	gelled	30	40	high order
M-1	settled	30	40-50	high order
NC*	gelled	55	60-65	low order
NC*	settled	55	65	low order
NC**	gelled	55	65	low order
NC**	settled	55	65	low order
TNT	gelled	40	60	high order
TNT	settled	40	55	high order
Comp B	gelled	30	40	high order
Comp B	settled	35	45	high order
M-9	gelled	40	50	high order
M-9	settled	40	50	high order
M-10	gelled	50	70	low order
M-10	settled	12.5	15	high order
M-10	settled	-	65	low order

*Nitrocellulose made from cotton linters

**Nitrocellulose made from wood pulp

***No propagation in 2 of 3 trials

Note: Gelled slurries were used to simulate the dynamic case.

REFERENCES (APPENDIX C)

1. C.D. Kalfadelis, "Development of a Fluidized Bed Incinerator for Explosives and Propellants," Esso Research & Engineering Co., Linden, NJ, Oct 73.
2. R.A. Knudsen, "Hazards Analysis of Pollution Abatement Techniques," Contractor Report A0262-520-03-007, Picatinny Arsenal, Dover, NJ, Jun 74.
3. D.E. Rolison, R.L. Dickenson, R. Scola, "Evaluation of an Incinerator for Waste Propellants & Explosives," Technical Report 4984, Picatinny Arsenal, Dover, NJ, Dec 76.
4. George Petino, et al, "Detonation Propagation Tests on Aqueous Slurries of RDX, HMX, M-1 and Nitrocellulose," Contractor Report ARLCD-CR-77002, ARRADCOM, Dover, NJ, Apr 77.
5. George Petino, et al, "Detonation Propagation Tests on Aqueous Slurries of TNT, Composition B, M-9 and M-10, TR4584, Picatinny Arsenal, Dover, NJ, Nov 73.
6. George Petino, et al, "Flow Characteristics of Explosive Slurry Injection System," Contractor Report ARLCD-CR-77004, ARRADCOM, Dover, NJ, Apr 77.

APPENDIX D. LOW COST SYSTEM DESIGN

As a followup to the successful evaluation of the fluidized bed incinerator for P&E waste, at ARRADCOM, a low cost 500 lb/hr (227 kg/hr), modular system was designed. This system (fig. D-1) incorporates all the design criteria mandated for safe, efficient operation as determined by the operation of the pilot unit. However, unlike the ARRADCOM pilot unit, it features only the instrumentation, controls, and emission monitoring apparatus required to operate efficiently. This system can be utilized at the various GOCO plants to safely dispose of their P&E wastes, while conforming to current and anticipated emission standards. A survey was conducted of the major fluidized bed companies, using the design criteria for the 500 lb/hr (227 kg/hr) incinerator module, as follows:

Chamber—A refractory lined unit with an internal diameter of 4 ft (1.22 m) and a total height of 20 ft (6.1 m) above the grid (8 ft (2.44 m) TDH and 12 ft (3.66 m) expanded bed height). It shall be capable of operating at temperatures in excess of 2500°F (1317°C), and designed for a maximum internal pressure of 8 psig (55160 Pa). The chamber shall have the capability for injection of secondary air, in-bed oil and the slurry.

Blower—The air blower requirements are 1500 std ft³/min at 8 psig (0.71 m³/sec at 55160 Pa) with the drive motor explosion-proof in full compliance with NEC-1971 for Class 1 - Groups C, D. Class II - Groups E, F and G.

Cyclone—The collector shall be capable of handling 5,000 ft³/min at 1.5 psig (2.36 m³/sec at 10.340 Pa) and 1700°F (927°C) with a cocked dipleg feeding back into the bed.

Instruments and Controls—This system includes the fuel and air analog control loops, along with the interlocks required for the safe operation of the system. The interlocks include flame safety units along with the preprogrammed purge cycles for system start, automatic required shutdown for emergency conditions, continuous system monitoring for out of tolerance conditions and the capability for monitoring CO₂ and NO_x for compliance with local standards.

Grid—Air distribution in the bed will be through a distributor plate (grid) so all holes will blow equally.

The cost estimates received for the above system ranged from \$210,000 - \$505,000 (August 1977). A reasonable cost figure for the above system including design, fabrication and preliminary checkout,

on-site supervision during erection, operator training, and start-up assistance is \$400,000. An optional heat exchanger for preheating the fluidizing air would be approximately an additional \$75,000.

The cost data for the slurry preparation building includes the following: two 500-gal (1.89 m³) mixing tanks with pumps and pneumatic mixers, instrumentation, piping, design and construction costs, grinder, conveyors, building, and miscellaneous items. These items would cost approximately \$210,000, giving a total cost of \$610,000 (\$685,000 with heat exchanger) for the entire 500 lb/hr (227 kg/hr) module, excluding land costs.

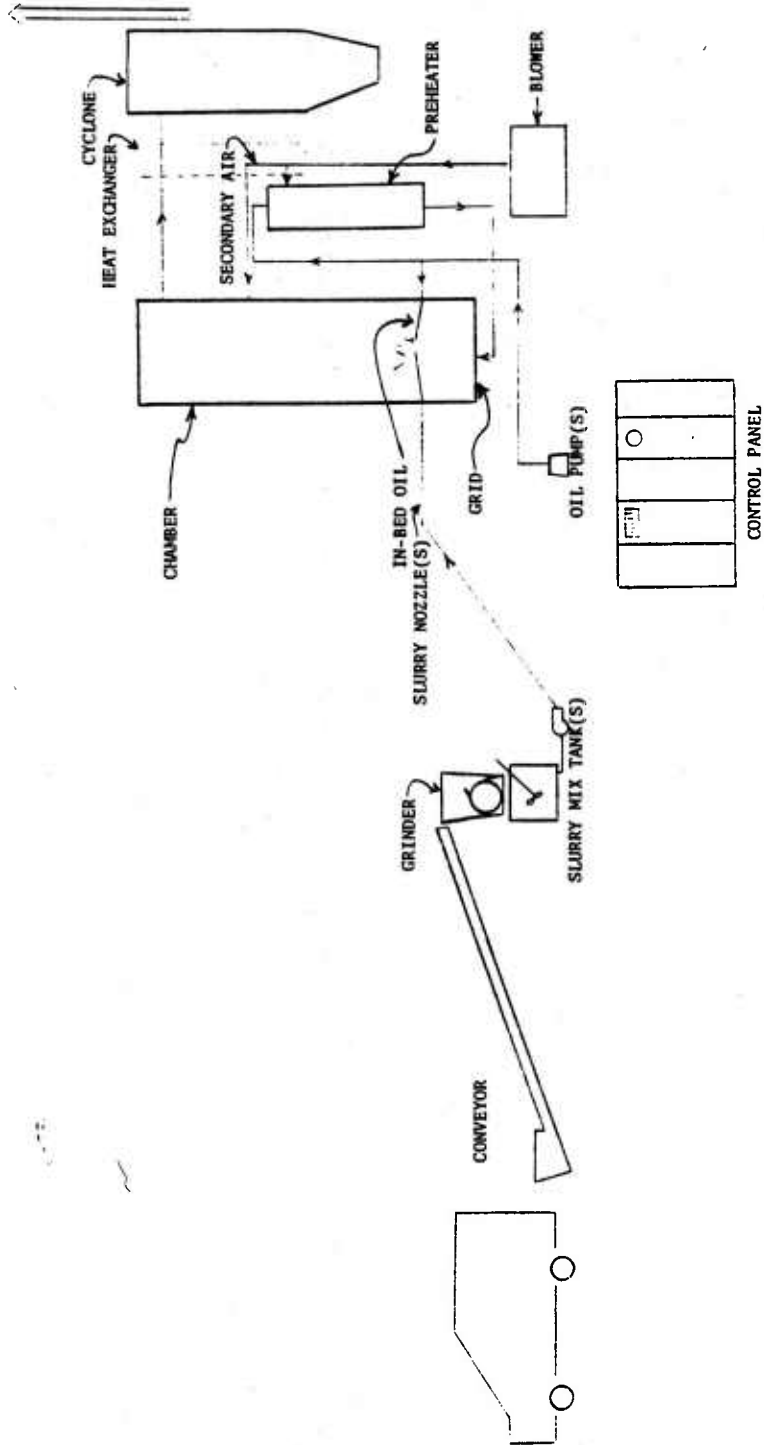

Figure D-1. Schematic of low cost system.

Figure D-1. Schematic of low cost system.

APPENDIX E. CATALYST AND ALTERNATE FUEL STUDY

1. INTRODUCTION

The NO_x emissions that result from the conventional combustion of high nitrogen content materials such as explosives, propellants and certain liquid fuels derived from petroleum, coal or shale materials are environmentally unacceptable. However, the controlled combustion of these high nitrogen materials in the presence of a nickel catalyst which is fluidized in a vertical reactor has been demonstrated as a viable technique for greatly reducing NO_x emissions from combustors burning high nitrogen content fuels. Furthermore, the addition of "secondary" combustion air to the fuel-rich fluidized bed "primary" combustion zone decreases the NO_x emissions compared to "unstaged" fluidized bed combustion in the presence of a nickel catalyst.

The utilization of this novel incineration technique requires the use of liquid or gaseous fuels to pre-heat the fluidized bed to a temperature at which self-sustaining combustion of the high-nitrogen content waste materials occurs. In large incinerators, where pre-heat fuel costs would be relatively high for low sulfur, low nitrogen distillate fuels or gaseous fuels, it would be economically advantageous to utilize less expensive distillate fuels which contain higher concentrations of sulfur, and in the case of coal or oil shale derived fuels, high nitrogen concentrations. The main disadvantage of utilizing high sulfur fuels in the presence of a catalyst is that catalyst deactivation may occur in a short period of time.

In order to determine the feasibility of utilizing high sulfur or high nitrogen fuels to pre-heat or augment the fluidized combustion process, a pilot-plant-scale research program was initiated at Exxon Research and Engineering Company. The main purpose of the study was to determine the short term effects of high sulfur fuel oils on the catalytic activity of a 30 wt. percent nickel catalyst which made up the fluidized bed.

2. PILOT SCALE PROCESS EQUIPMENT AND OPERATION

2.1 Combustion System

The pilot-scale experimental fluidized bed combustion system is shown schematically in Figure 2-1. In operation, waste for disposal, auxiliary fuel, and air are simultaneously fed to the fluidized bed combustor. Issuing flue gases pass through a cyclone separator before being vented. A slip-stream continuously feeds the analytical train.

The combustor shell was fabricated from six-inch, Schedule 40, RA-330 high-temperature alloy pipe. RA-330 (Rolled Alloys, Inc., Detroit, Michigan) was chosen for this service because of its ability to withstand repeated cycling to temperatures of about 1900°F. RA-330 is an austenitic, non-hardenable heat and corrosion-resistant alloy which possesses good high-temperature strength, oxidation and carburization resistance to 2200°F, and whose properties are enhanced by a 1.25% nominal silicon content. It is immune to sigma phase formation at all sigma phase forming temperatures. Its nominal composition is 19-35-43-1.5-1.25 (Cr-Ni-Fe-Mn-Si).

Pipe sections welded to the combustor shell above the air distributor grid are also of RA-330 alloy. The mating air plenum chamber below the air-distributor grid and associated low-temperature fittings are fabricated of Types 304 and 316 stainless steels.

The combustor shell is nine feet long overall. The air plenum chamber is one foot long. The combustor is free-standing on its own support legs, so that longitudinal thermal expansion may occur in both directions about the point of attachment of the leg support plates about four feet above the air-distributor grid. Attached piping is arranged with bellows-type expansion sections to minimize thermal stresses. The mean coefficient of thermal expansion for RA-330 between 70° and 1800°F is 10.2×10^{-6} inch/inch/°F.

The combustor was used in two configurations. In the normal configuration (Figure 2-2), the catalyst (if any) was contained in the fluidized bed itself. Fuel and primary air, along with nitrogen-containing waste for disposal, were injected at the bottom of the fluidized bed, while secondary air was injected near the middle of the expanded bed. In the modified configuration (Figure 2-3) the catalyst was contained in a separate fixed bed suspended above the non-catalytic fluidized bed. Fuel and primary air, along with nitrogen-containing waste for disposal, were injected at the bottom of the fluidized bed. In this configuration, secondary air was injected above the catalytic fixed bed, resulting in a reducing atmosphere passing over the catalyst to promote reduction of NO_x .

PROCESS FOR THE CONTROLLED DESTRUCTION OF EXPLOSIVES AND PROPELLANTS

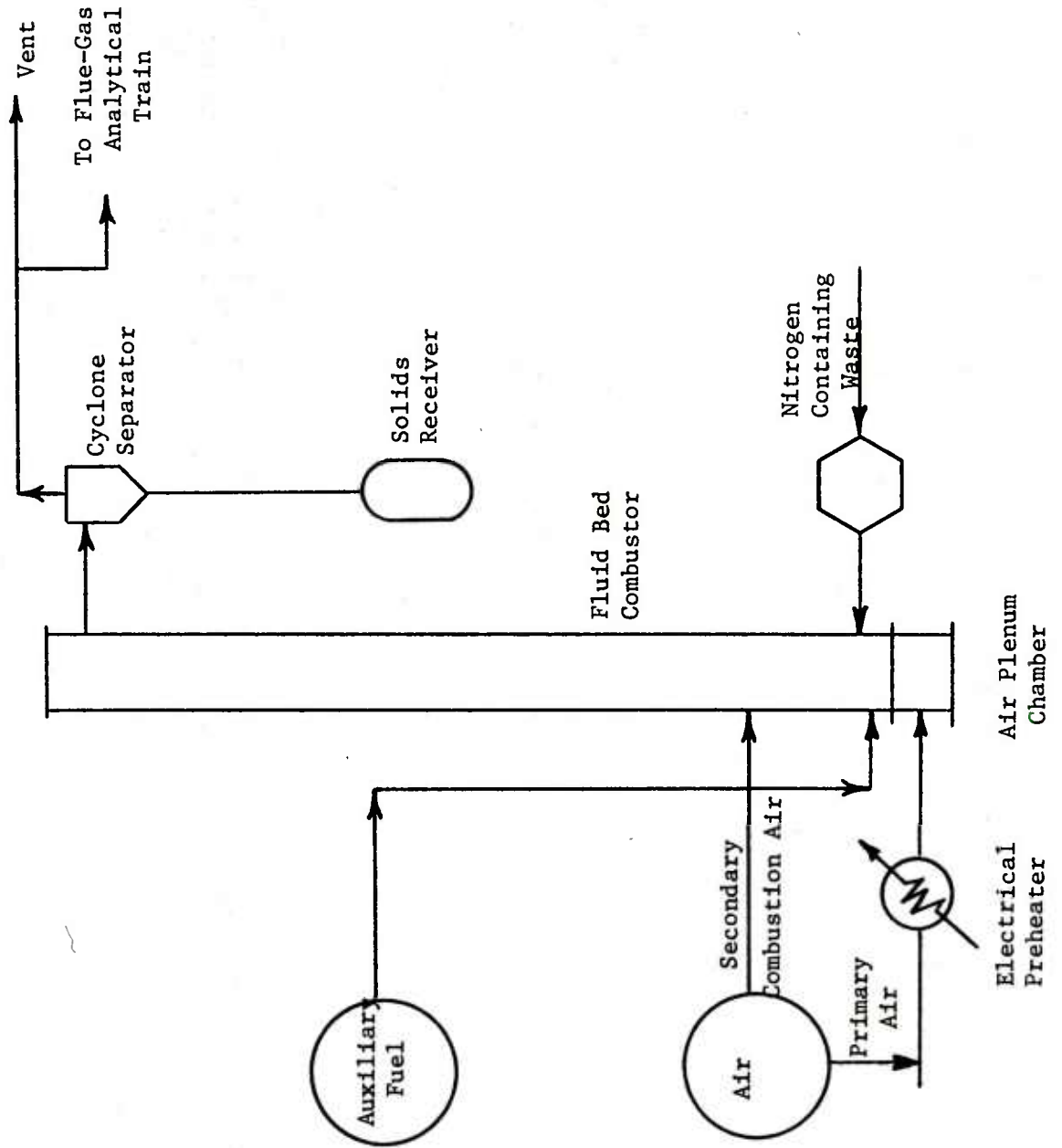

CATALYTIC FLUIDIZED BED INCINERATOR

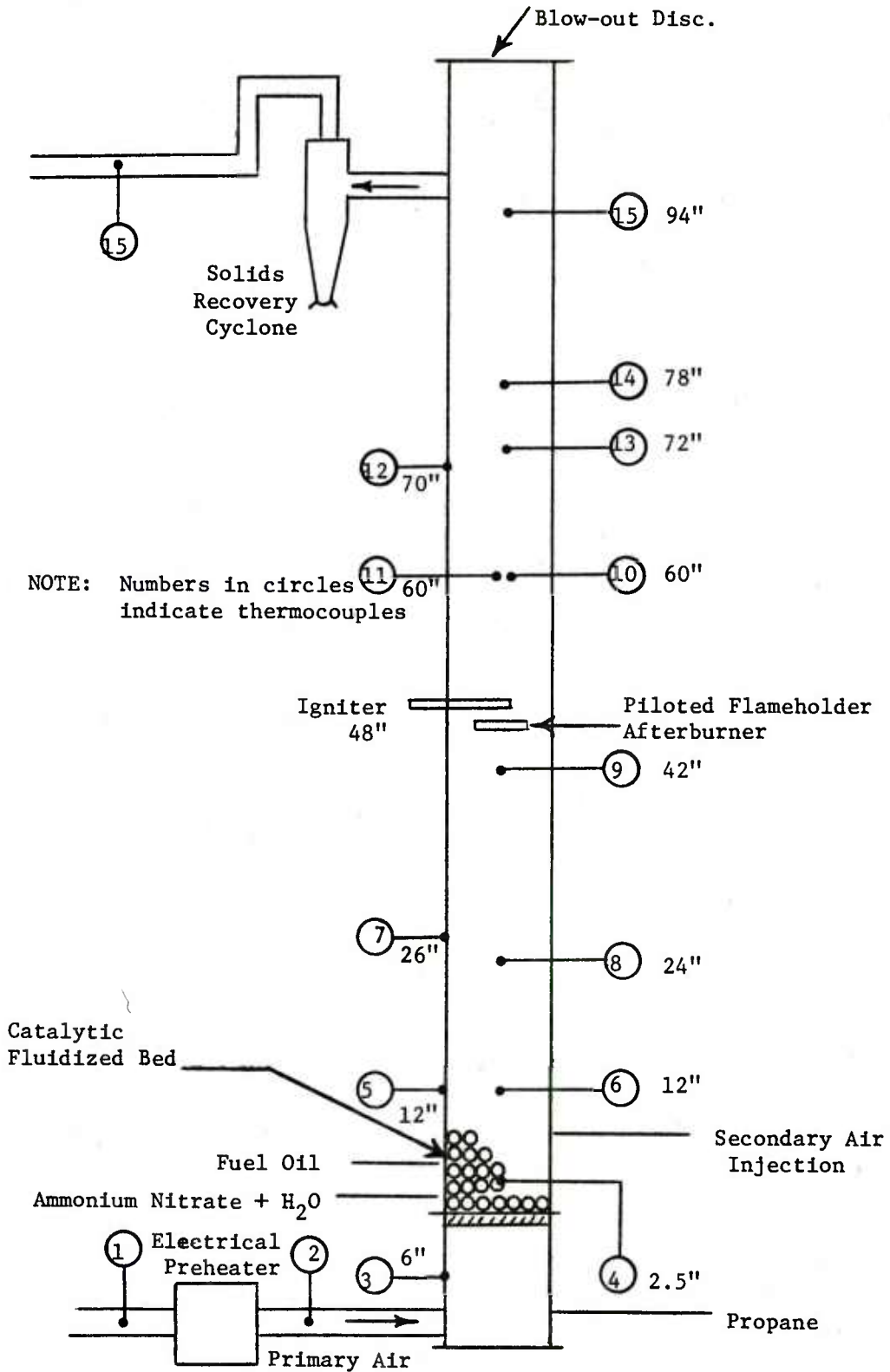

FLUID BED INCINERATOR WITH SEPARATE FIXED CATALYST BED

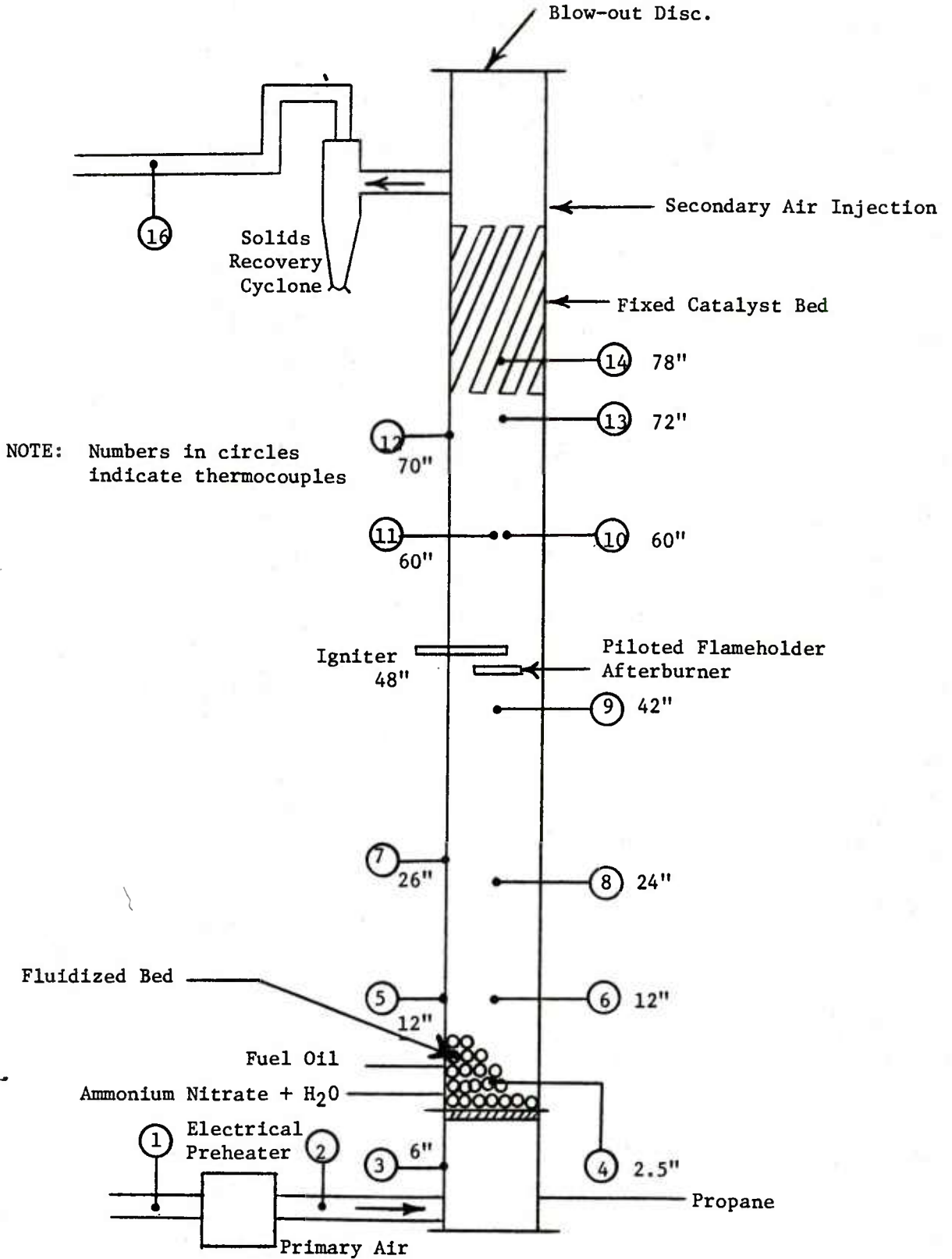

2.2 Analytical Instrumentation

Figure 2-4 is a simplified schematic showing major components of the flue-gas monitoring system for the experimental fluidized bed incinerator. In the figure, the labeled boxes indicated continuous electronic monitors and recorders for the indicated components of flue-gas.

A single flue-gas slipstream is drawn from the vent-line off the top of the cyclone solids separator. This stream is split in parallel to each of the gas analyzers. A separate pump is used as a booster on the NO_x analyzer, which is able to accept higher flows than the other instruments, to minimize analytical lag time.

In operation, flue-gas flows in parallel to each instrument continuously. Through appropriate valving, any instrument may be taken off the train at any time and calibrated with standard gases piped to the unit from an adjoining high-pressure cylinder rack. Standard cylinder regulators are used for pressure reduction, and each high-pressure line is suitably pressure relieved and protected against overflow and backflow. Continuous visual indication of flow to each instrument is provided by rotameters mounted on the instrumentation console.

The specific instruments in the flue-gas analytical train are the following:

<u>Component</u>	<u>Model</u>	<u>Manufacturer</u>	<u>Type</u>
NO-NO _x	10A	Thermo Electron	Chemi-luminescent
O ₂	778	Beckman	Polarographic
CO	IR-315B	Beckman	NDIR

2.3 Operating Procedures for Fluidized Bed Incinerator

Standard operating procedures and shutdown procedures for the pilot-scale fluidized bed incinerator are presented in this section for reference. The reader is directed to Figure 2-2 for identification of incinerator parts.

Standard Procedures for FBI

Before startup -

- verify combustor temperature at ambient by observing recorder and controllers
- all combustor heat and power switches off

FLUIDIZED BED TNT INCINERATION - ANALYTICAL INSTRUMENTATION

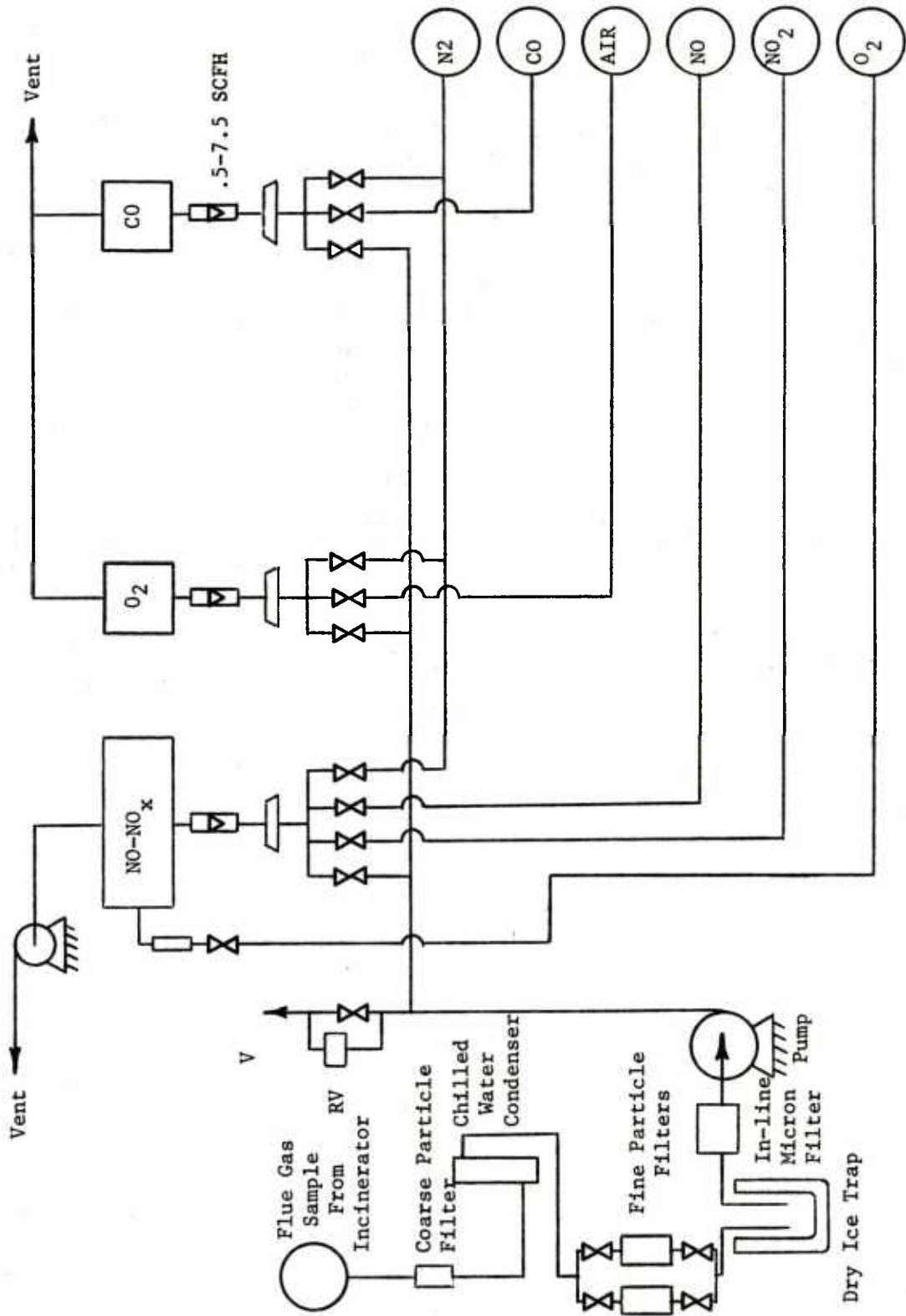

- pilot propane off
- pilot igniter off
- air flow into combustor off except for flange air
- check igniter spark if necessary
 - if pilot must be disassembled, must realign spark gap

Analyzer train

- open drain valve on coarse filter to drain water
- make sure one fine filter has valves open and spare fine filter has valves closed
- put dry ice/trichloroethane in traps
- make sure valve on main sample line at analyzers is open
- plug in sample pump
- nitrogen should be flowing to instruments on idle

Incinerator Startup

- turn on master propane supply
- make sure oil nozzle nitrogen purge is on
- make sure flange air is on
- cooling condenser for analytical train on
- dry ice in traps
- main air into combustor plenum
- turn on control panel
 - test reset and acknowledge button
 - on condition button
 - temperature recorder on
 - air preheater on
 - igniter on
 - pilot propane on

- while heating unit, calibrate instruments
- when TC10 reaches 1700-1800°F, very slowly (15-20 mins) reduce pilot propane and increase (lower burner) main propane. Adjust bottom air if necessary
 - watch TC to be sure flame is moving lower
 - eventually all propane from lower burner
- when TC4 \sim 1600°F pilot propane should be off
 - turn up bottom propane if necessary and turn up bottom air to heat up TC6 and 8
- when TC4, 6, 8 \sim 1600°F turn N₂ off, heaters off, turn igniter off, propane off and fuel oil on
- adjust bottom air for proper stoichiometry
- adjust secondary air as necessary
- if temperature exceeds 1950°F, turn on bottom water to maintain temperature (2100°F absolute upper limit).

Incinerator Operation

- as indicated in Experimental Results Section

Incinerator Shutdown

- shut off oil switch on main panel
- high pressure N₂ nozzle purge on full
- turn up primary air for cooldown
- allow unit to cool to below 1000°F
 - switch nozzle purge to low pressure N₂
 - recheck calibration and zero for instruments
 - switch sample system to N₂ purge
- hit emergency off to prevent actuation of propane, heaters, etc.
 - recorder remains on

- shut off all cylinders
 - calibration gas
 - feed gas
 - propane
- when finished
 - recorders off
 - panel off
 - main air at 10-15% (R4)
 - flange air at 80%

3. EXPERIMENTAL RESULTS

The purpose of the experimental program was to test and evaluate catalytic fluidized bed incineration of nitrogen-containing wastes using low-cost sulfur containing fuels. This program was carried out in a series of tasks in which:

- (a) The performance of alternate fuels in the fluidized bed incinerator was evaluated. The fuel injection and operating conditions necessary to achieve stable combustion were demonstrated.
- (b) The rate of sulfur contamination of the nickel catalyst used for chemical destruction of NO_x was studied.
- (c) Catalytic activation was studied in the fluidized bed incinerator pilot unit. The fluid bed incinerator was modified to enable operation as a two-stage reactor with a separate catalytic bed. Tests of the effectiveness of this approach on achieving NO_x reduction were conducted.

The first series of tests was designed to evaluate the performance of alternate fuels in the fluidized bed incinerator (FBI). Previous FBI studies had been accomplished with gaseous fuels. Liquid fuels such as fuel oil had not been demonstrated in previous programs for the Army. It was expected, however, that both liquid and solid fuels would be practical alternatives since they have been used in other fluidized bed applications such as gasification and combustion for boiler applications. Two different sulfur content fuels were used. The low-sulfur fuel contained 0.18% sulfur and the high sulfur fuel contained 1.4% sulfur.

The first test, Run 101, was accomplished with a non-catalytic bed consisting of 19 lb of tabular alumina, (-14 to +45 mesh) Alcoa T-61. The fuel was #2 fuel oil doped with pyridine to yield a 2% nitrogen fuel. The addition of nitrogen to the fuel oil permitted testing the conversion of fuel nitrogen to NO_x in the fluidized bed incinerator prior to the addition of nitrogen-containing material in an aqueous medium. The conversion of fuel nitrogen to NO_x over a mixture ratio ranging from 94% to 138% of the stoichiometric air requirement is indicated in Figure 3-1. The maximum NO_x concentration measured was 310 ppm at 138% stoichiometric air which represents only a 17% conversion of fuel nitrogen to NO_x . This compares with 30-35% conversion normally found in conventional boilers when burning high nitrogen fuels and 12-20% conversion in the Exxon pressurized fluidized bed combustor when burning coal (about 17% at 140% stoichiometric air). The overall results are shown in Table 3-1. Mild staging (94% stoichiometric air primary) was tested and found to be moderately effective (about 33% reduction in NO_x compared to unstaged combustion at the same overall stoichiometry). Staging was accomplished via injection of air into the combustion in a zone above the dilute phase fluidized bed. The f/a ratio in the dilute phase of the bed was always more fuel-rich than the overall f/a ratio in the zone where staging was carried out.

Run 101

NO_x Concentration Vs. Mixture Ratio in
Fluidized Bed Incinerator with Non-Catalytic Bed
Using #2 Fuel Oil with 2 Wt % N

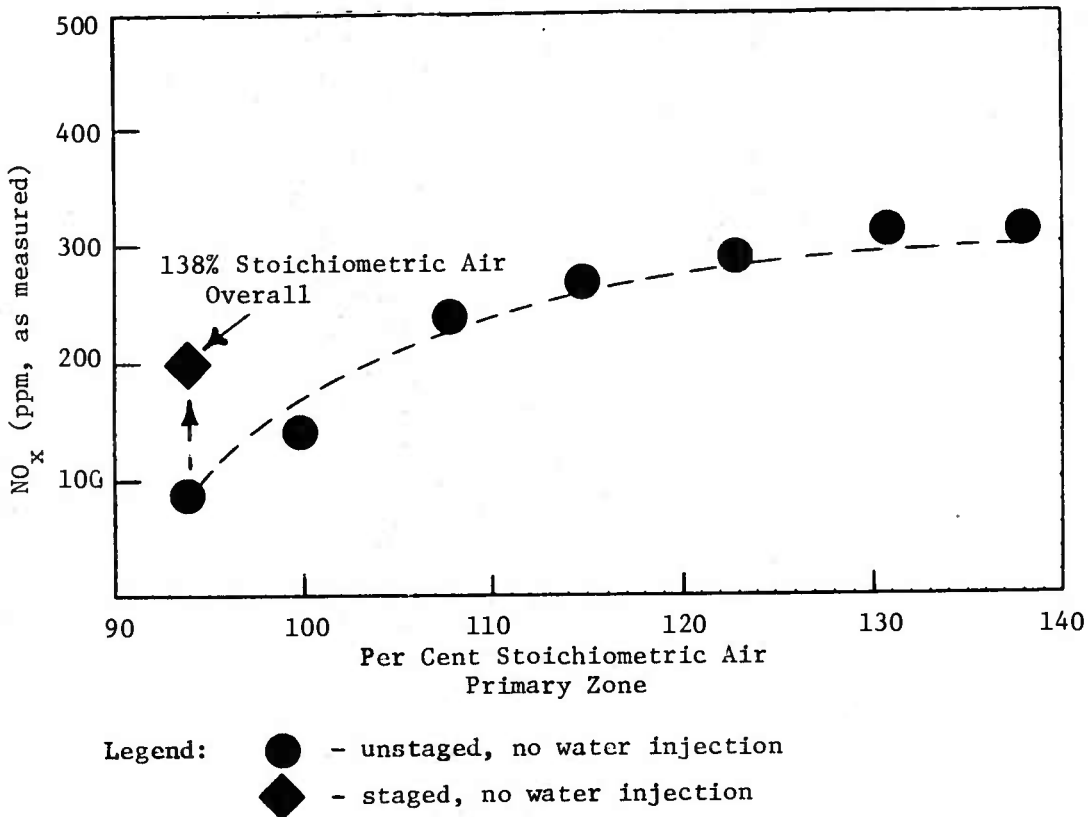

Table 3-1

Run 101

Fuel Rate (GPH)	Primary Zone Stoichiometry (When Staging)	Overall Stoichiometry	NO _x (ppm)	O ₂ (pct)	CO (ppm)	Mid-Bed Temp (°F)
0.65		131	310	4.75	100	1740
0.65		123	290	3.75	100	1760
0.65		115	270	3.00	110	1780
0.65		108	220	1.50	220	1800
0.65		100	140	0.45	2800	1820
0.65		94	90	0.03	7000	1840
0.65	94	131	200	4.80	110	1850
0.65		138	310	5.50	100	1790

The second test, Run 102, was conducted with the same fuel and the same bed, but water injection was tested and deeper staging was tested. The results (Figure 3-2 and Table 3-2) for unstaged combustion were in excellent agreement with the results obtained in Run 101 and water addition did not affect the results obtained in Run 101 and water addition did not affect the NO_x emissions even though substantial bed temperature differences were noted. Deeper staging (74% stoichiometric air in the primary zone) showed no additional benefit over the milder staging in Run 101; in fact the NO_x emissions appeared to be somewhat higher, even after correction for dilution. As a result of this run, operating conditions for staging and water injection were established.

Figure 3-2

Run 102

NO_x Concentration Vs. Mixture Ratio in
Fluidized Bed Incinerator with Non-Catalytic Bed
Using #2 Fuel Oil with 2 Wt % N

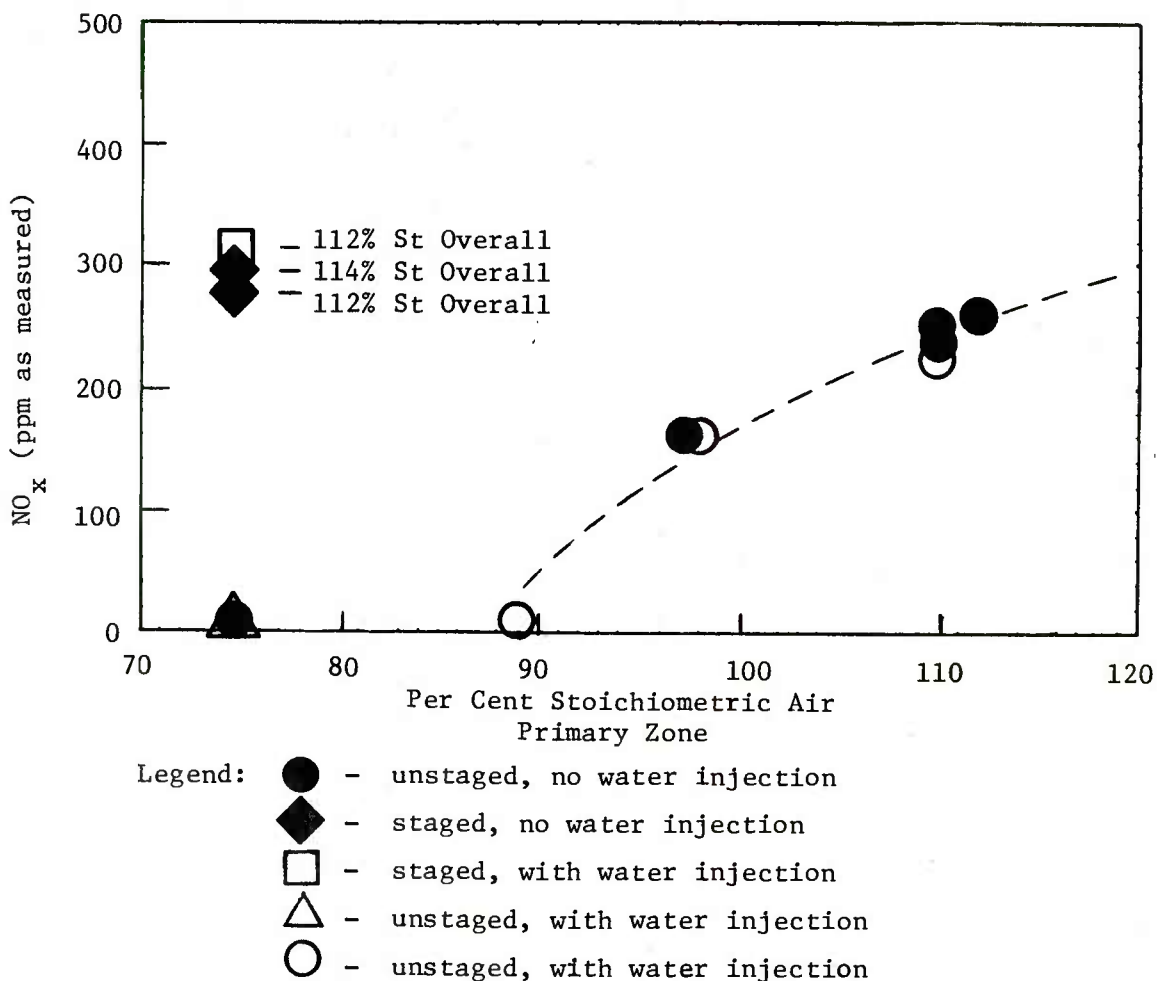

Run 102

<u>Fuel Rate (GPH)</u>	<u>Primary Zone Stoichiometry (When Staging)</u>	<u>Overall Stoichiometry</u>	<u>Water Addition (lb/hr)</u>	<u>NOx (ppm)</u>	<u>O₂ (pct)</u>	<u>Mid-Bed Temp (°F)</u>	<u>CO (ppm)</u>
0.65		112		260	2.25	1740	270
0.65		98		160	0.65	1810	3850
0.65		75		10	0.25	1820	>8000
0.65	75	114		300	2.60	1820	175
0.65	75	112		285	2.25	1820	100
0.65		110		250	2.05	1850	230
0.65		110	14	230	1.95	1640	950
0.65		110		240	2.05	1750	250
0.65	75	112	14	310	1.80	1660	50
0.65		75	14	10	0.20	1640	8000
0.65		89	14	10	0.30	1560	8000
0.65		89	4.7	10	0.25	1600	7950
0.65		98	4.7	160	0.70	1700	3350

Run 103

Fuel Rate (GPH)	Primary Zone Stoichiometry (When Staging)	Overall Stoichiometry	Water (W) Ammonium Nitrate (A) Solution (lb/hr)	NOx (ppm)	O ₂ (pct)	Mid-Bed Temp (°F)	CO (ppm)
0.65		115		310	2.8	1790	100
0.65		115	4.7 (W)	300	2.8	1780	150
0.65		115	4.7 (A)	1500	3.0	1760	200
0.65		88	4.7 (A)	<50	0.04	1750	>8000
0.65	88	127	4.7 (A)	620	4.4	1750	100
0.65	80	112	4.7 (A)	700	2.25	1760	75
0.65	80	112	4.7 (W)	380	1.5	1790	75
0.65		115	4.7 (W)	300	2.55	1740	150
0.65*		115	4.7 (W)	80	2.7	1740	200

 * #2 fuel oil with 1.4% S, 0.03% N

Run 103

NO_x Concentration Vs. Mixture Ratio in
 Fluidized Bed Incinerator with Non-Catalytic Bed
 Using #2 Fuel Oil with 2 Wt % N (Except as Noted)

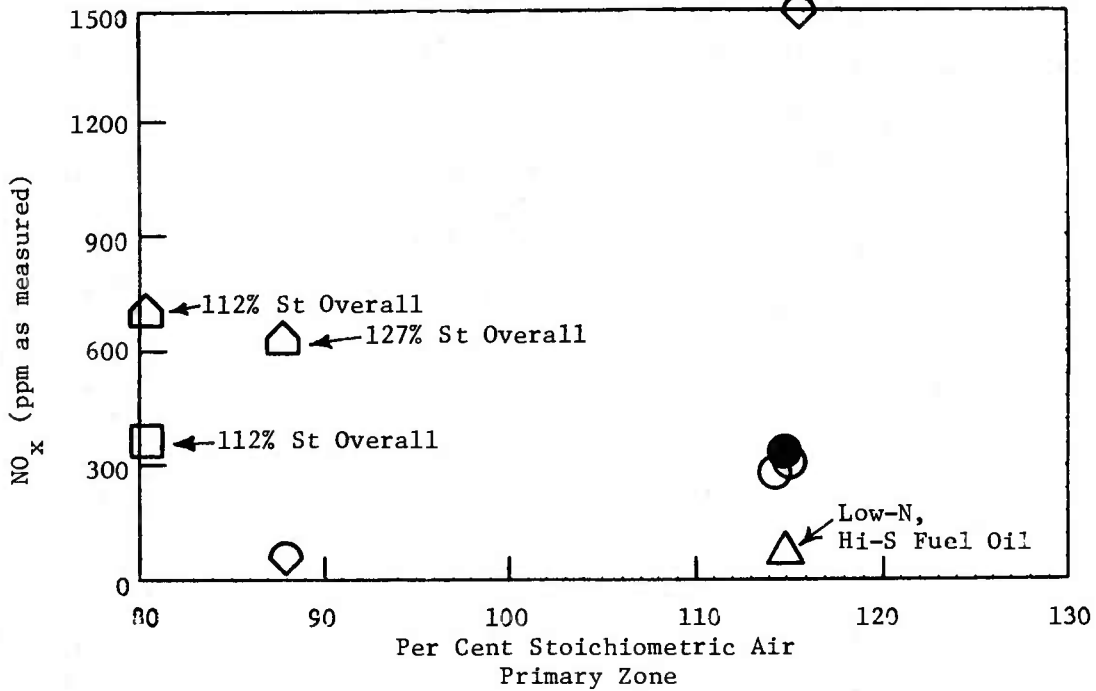

- Legend:
- △ - unstaged, no water injection, low nitrogen and high sulfur fuel oil
 - ◡ - staged, with ammonium nitrate injection
 - ◊ - unstaged, with ammonium nitrate injection
 - ◻ - staged, with water injection
 - - unstaged, with water injection
 - - unstaged, no water injection

During Run 103 an aqueous solution (10 wt. %) of ammonium nitrate was injected with the nitrogen-doped fuel oil and high sulfur oil (1.8% S) was tested for stable combustion conditions. Water injection alone was found to have essentially no effect on NO_x emissions at 115% stoichiometric air (see Table 3-3 and Figure 3-3). However when a 10 wt. % solution of ammonium nitrate was injected at 4.7 lb/hr, the emissions (115% stoichiometric air) increased to 1500 ppm. When the stoichiometry was dropped to 88% stoichiometric air, NO_x emissions decreased to below 50 ppm but when staged air was added to bring the overall stoichiometry to 127% of theoretical air the NO_x increased to 620 ppm. Deeper staging resulted in almost no change in NO_x when corrected for dilution; with 80% primary air and 112% overall air NO_x emissions were 700 ppm (without ammonium nitrate in the water emissions were 380 ppm under the same conditions). When a high sulfur (1.8% S), but low nitrogen (undoped #2 fuel oil) fuel was used, the measured combustion parameters remained unchanged except for NO_x , which dropped to 80 ppm without ammonium nitrate injection. As a result of run 103, the operating conditions while using ammonium nitrate injection were established.

In Run 104, two pounds of Girdler G-65 catalyst, 30% nickel on alumina in the form of cylinders 0.2 inches in diameter and ranging in length from 0.1 to 0.5 inches, was put in a wire mesh basket installed about six feet above the fluidizing grid. In this configuration the gases coming from the fluidized bed at the bottom of the incinerator must pass through the fixed bed of catalyst installed in the basket. Provisions were made to inject secondary air above the fixed catalyst bed to allow the fuel rich gases to react while passing through the catalyst bed and then burn out the partial combustion products above the catalyst. Preliminary tests were also run on sulfur poisoning of the catalyst. The fuel itself was not doped with nitrogen but aqueous ammonium nitrate (10 wt. %) was added as nitrogen waste for disposal.

With ammonium nitrate (10% solution) added to the incinerator at 10.6 lb/hr (equivalent to 10,000 ppm of NO_x at full nitrogen conversion) the NO_x emissions for unstaged combustion were on the order of 1800 ppm (corrected for dilution) which is the same percentage conversion found when the fuel itself was doped with nitrogen. The results for low sulfur fuel (Figure 3-4) and high sulfur fuel (Figure 3-5) are consistent. (See Table 3-4) Unstaged combustion resulted in NO_x emissions of 1600 ppm (as measured, uncorrected for dilution) while staged combustion with the primary zone in the range of 75-85% of theoretical air dropped the NO_x emissions into the range of 400 ppm. Unstaged combustion with the primary zone at 85% stoichiometric air also resulted in NO_x emissions of about 400 ppm with ammonium nitrate injection.

Run 104

NO_x Concentration Vs. Overall Mixture Ratio
Fixed Catalytic Bed Above Non-Catalytic
Fluidized Bed Using Low Sulfur Fuel (0.18%)

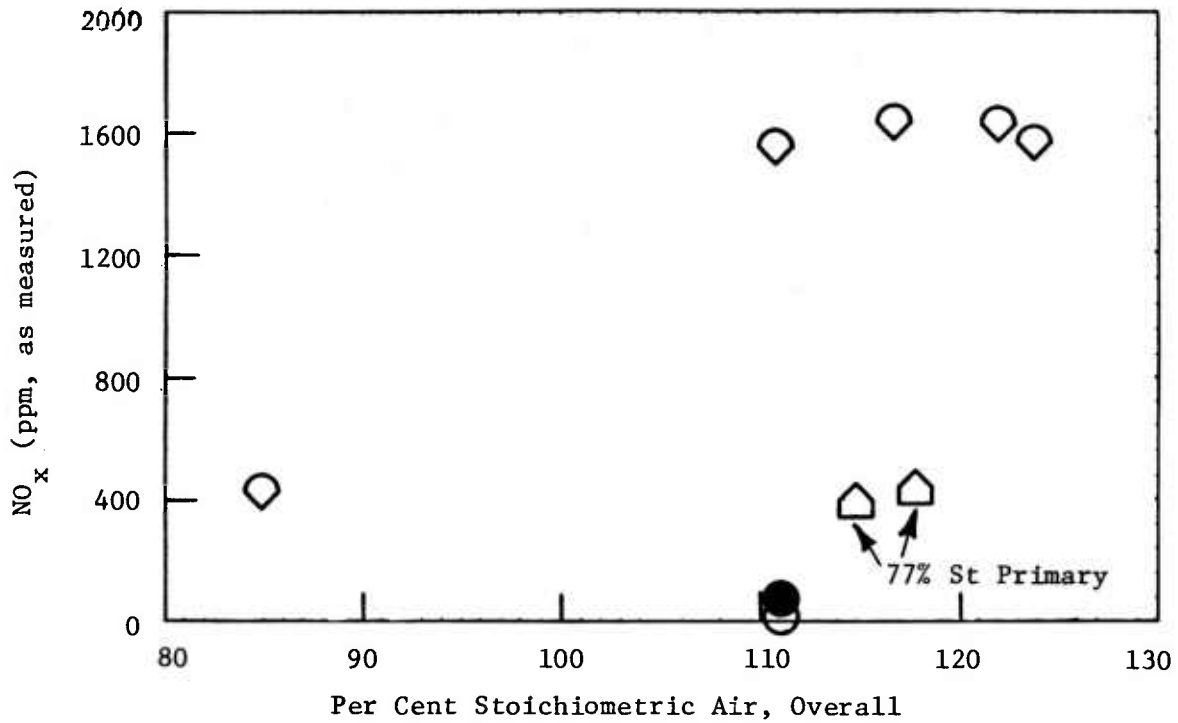



- Legend:
- - unstaged, with water injection
 - - unstaged, no water injection
 - ◇ - unstaged, with ammonium nitrate injection
 - ◇ - staged, with ammonium nitrate injection

Run 104

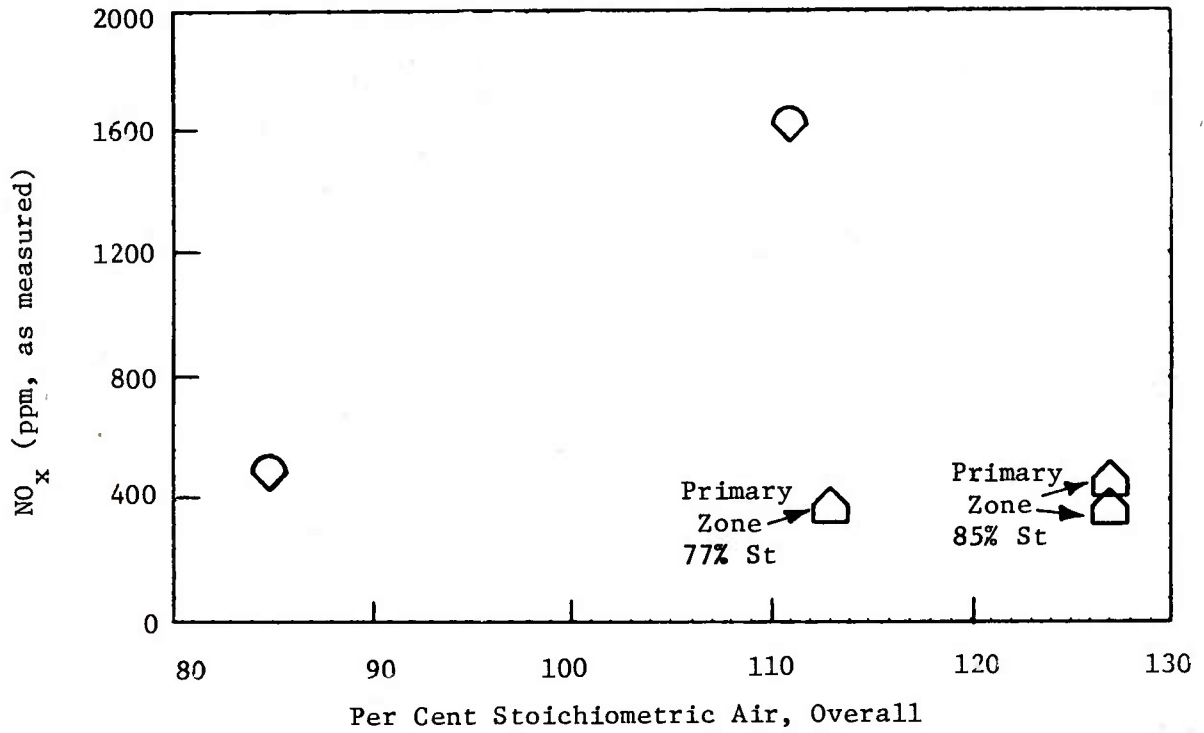
NO_x Concentration Vs. Overall Mixture Ratio
Fixed Catalytic Bed Above Non-Catalytic
Fluidized Bed Using High Sulfur Fuel (1.4%)



Legend:  - unstaged, with ammonium nitrate injection
 - staged, with ammonium nitrate injection

Run 104

Fuel Rate (GPH)	Primary Zone Stoichiometry (When Staging)	Overall Stoichiometry	Ammonium Nitrate 10 wt % Solution (lb/hr)	NO _x (ppm)	CO (ppm)	O ₂ (pct)	Mid		Catalyst Bed Temp (°F)
							Fluid Bed Temp (°F)	Bed Temp (°F)	
(a) Low Sulfur									
0.65		111	0	70	175	2.1	1680	1670	
0.65		111	*	30	1300	1.6	1760	1590	
0.65		111	4.7	480	1450	1.7	1780	1590	
0.65		111	10.6	1550	2800	1.75	1700	1630	
0.65		124	10.6	1575	200	4.05	1600	1590	
0.65		85	10.6	450	>8000	0.9	1585	1570	
0.65		122	10.6	1650	300	3.75	1570	1570	
0.65		117	10.6	1650	500	3.1	1570	1450	
0.65	77	115	10.6	380	7150	2.75	1565	1430	
0.65	77	118	10.6	420	2550	3.25	1540	1380	
0.65		111	0	50	300	2.35	1650	1510	
(b) High Sulfur									
0.65		111	10.6	1625	2050	2.25	1660	1550	
0.65	77	113	10.6	350	6550	3.3	1615	1450	
0.65	85	127	10.6	350	5600	4.5	1580	1390	
0.65		85	10.6	500	>8000	0.85	1565	1390	
0.65	85	127	10.6	450	7250	5.0	1560	1300	

* Water only at 10.6 lb/hr.

The results in Run 104 for staged combustion with a fixed catalyst bed indicated a reduction of about 75% in the NO_x emissions compared to those for unstaged combustion in a non-catalytic fluidized bed. This indicates a drop in conversion of the nitrogen contained in waste for disposal from about 16% to about 4%, i.e., only 400 ppm emissions for a nitrogen input equivalent to 10,000 ppm of NO_x .

In Run 105, the five pounds of nickel catalyst (Girdler T-2060, 4% Ni on T61 Alumina, -14 to +45 mesh) was placed in the fluidized bed itself to test the effectiveness of staged catalytic combustion and to test catalyst poisoning by sulfur compounds. A twenty weight percent ammonium nitrate solution was used at an injection rate of 4.7 lb/hr. Fuels used in this run were propane (no sulfur), #2 fuel oil (low sulfur), and #2 fuel oil doped with thiophene (high sulfur). The results are shown in Table 3-5.

In the first part of the run, propane was used as the fuel to condition the catalytic bed and make preliminary checks on effectiveness. It was found (Figure 3-6) that NO_x levels were easily reduced by 75% with staging compared to unstaged operation, although this performance is not significantly different than for non-catalytic operation. It was found, however, that the NO_x concentration went to zero at about 85% stoichiometric air and below, compared to concentrations of about 400 ppm found in Run 104 (Figures 3-4 and 3-5).

After about two hours on propane, the fuel was switched to low sulfur fuel oil and the series of conditions was repeated (Figure 3-7). NO_x levels for unstaged combustion were somewhat higher than for propane, reaching 1250 ppm at 124% stoichiometric air. However, at 85% stoichiometric air and below, the NO_x level went to zero. Using staged combustion, the NO_x level was near zero with the primary zone at 77% stoichiometric air and the overall stoichiometry between 117 and 126% stoichiometric air. With the primary zone at 85% stoichiometric air, the NO_x level increased to 280 ppm which is about an 80% reduction from unstaged combustion.

Run 105

Fuel	Primary Zone Stoichiometry (When Staging)	Overall Stoichiometry	Ammonium Nitrate (20 wt %) Solution (lb/hr)	CO (ppm)	NO _x (ppm)	O ₂ (pct)	Mid Fluid Bed Temp (°F)	
Propane		112	0.	1000	0	1.85	1760	
		112	4.7	500	480	2.10	1750	
		125	4.7	100	700	4.25	1700	
		85	4.7	>8000	0	0.3	1670	
		78	4.7	>8000	0	0.25	1680	
	78	117	4.7	200	150	3.0	1700	
	78	126	4.7	100	160	4.3	1720	
		112	4.7	400	550	2.6	1640	
	85	131	4.7	100	190	5.0	1650	
		112	0.	200	0	3.0	1690	
	Low Sulfur Fuel Oil		111	0.	300	0	1.8	1830
			111	4.7	450	700	1.75	1860
			124	4.7	100	1250	4.1	1850
			85	4.7	>8000	0	0.4	1760
		77	4.7	>8000	0	0.3	1730	
77		117	4.7	2150	0	0.7	1720	
77		126	4.7	150	0	2.0	1710	
85		131	4.7	100	280	3.5	1710	
		111	0.	150	20	2.1	1860	

Run 105

Fuel	Primary Zone Stoichiometry (When Staging)	Overall Stoichiometry	Ammonium Nitrate (20 wt %) Solution (lb/hr)	CO (ppm)	NO _x (ppm)	O ₂ (pct)	Mid Fluid Bed Temp (°F)
High Sulfur Fuel Oil	76	110	0.	350	20	1.5	1870
		110	4.7	550	825	1.7	1850
		123	4.7	100	1200	3.95	1840
		84	4.7	>8000	0	0.35	1760
		76	4.7	>8000	0	0.3	1760
	76	117	4.7	200	0	1.7	1740
	76	126	4.7	100	210	2.75	1720
	84	131	4.7	100	210	3.15	1720
	76	117	4.7	1000	170	0.75	1720
	76	126	4.7	100	180	2.05	1720

Run 105

NO_x Concentration Vs. Overall Mixture Ratio
Catalytic Fluidized Bed Using Propane Fuel

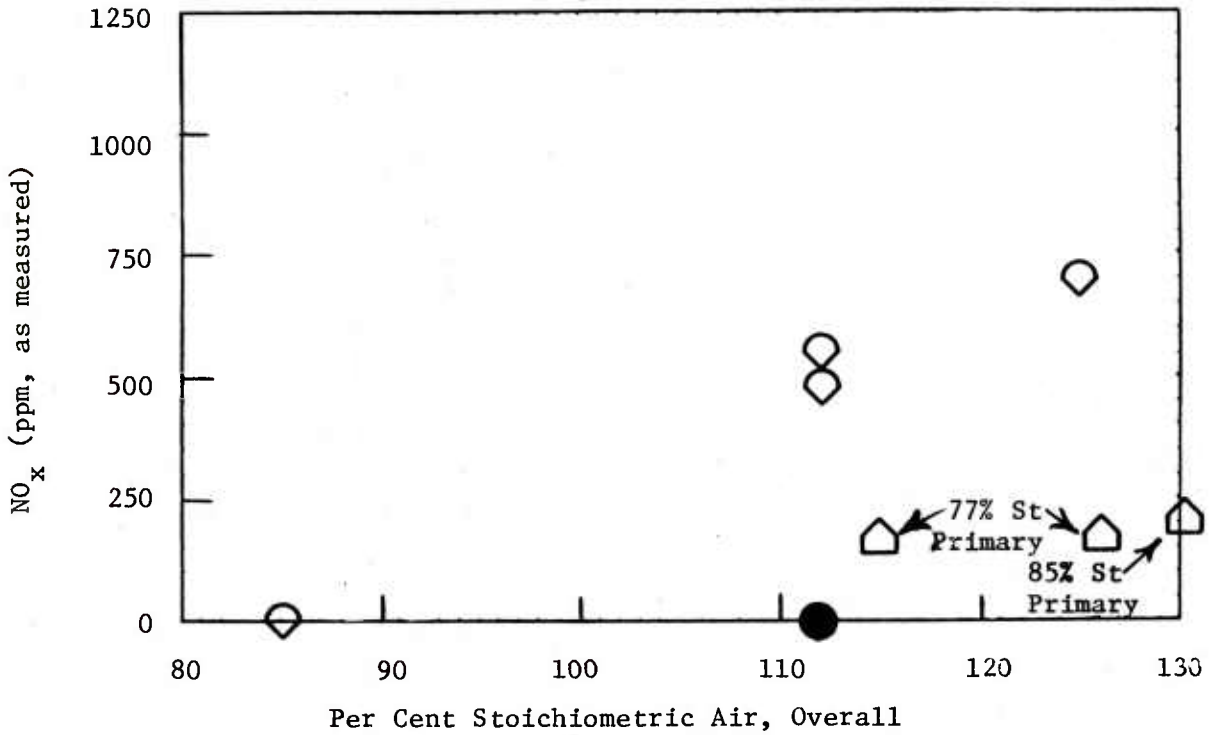

- Legend:
- - unstaged, no water injection
 - ◇ - unstaged, with ammonium nitrate injection
 - ⌠ - staged, with ammonium nitrate injection

Run 105

NO_x Concentration Vs. Overall Mixture Ratio
Catalytic Fluidized Bed Low Sulfur Fuel Oil (0.18% S)

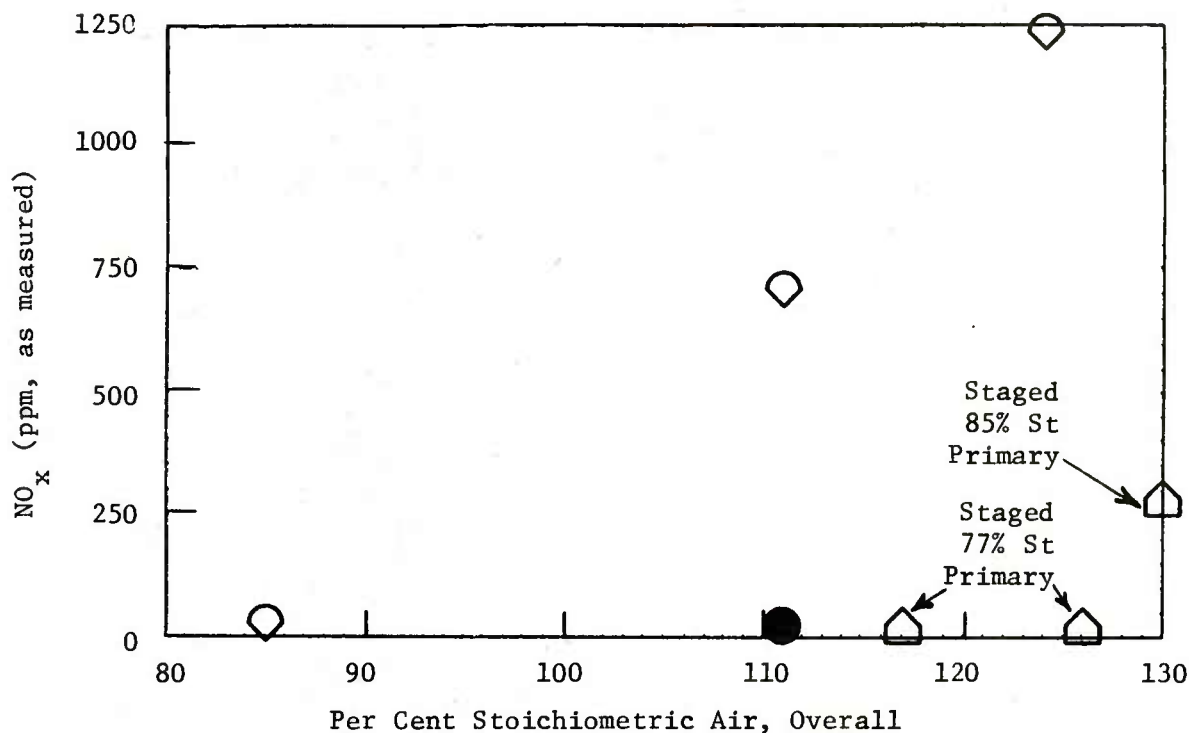

- Legend:
- - unstaged, no water injection
 - ◊ - unstaged, with ammonium nitrate injection
 - ◡ - staged, with ammonium nitrate injection

After about two hours on low sulfur fuel oil, the fuel was switched to high sulfur oil and the series of conditions was repeated (Figure 3-8). Early after the switch, the results duplicated the results for low sulfur fuel, but after about one and a half hours some decrease in catalytic effectiveness was apparently observed. As an indication of this behavior, the NO_x emissions when staging at 76% stoichiometric air in the primary and 117% overall were near zero after one hour of running, while they were 170 ppm after two hours of running. After the one and a half hour point, the NO_x emissions for staging were in the 170-210 ppm range.

Run 105

NO_x Concentration Vs. Overall Mixture Ratio
Catalytic Fluidized Bed
High Sulfur Fuel Oil (2% S)

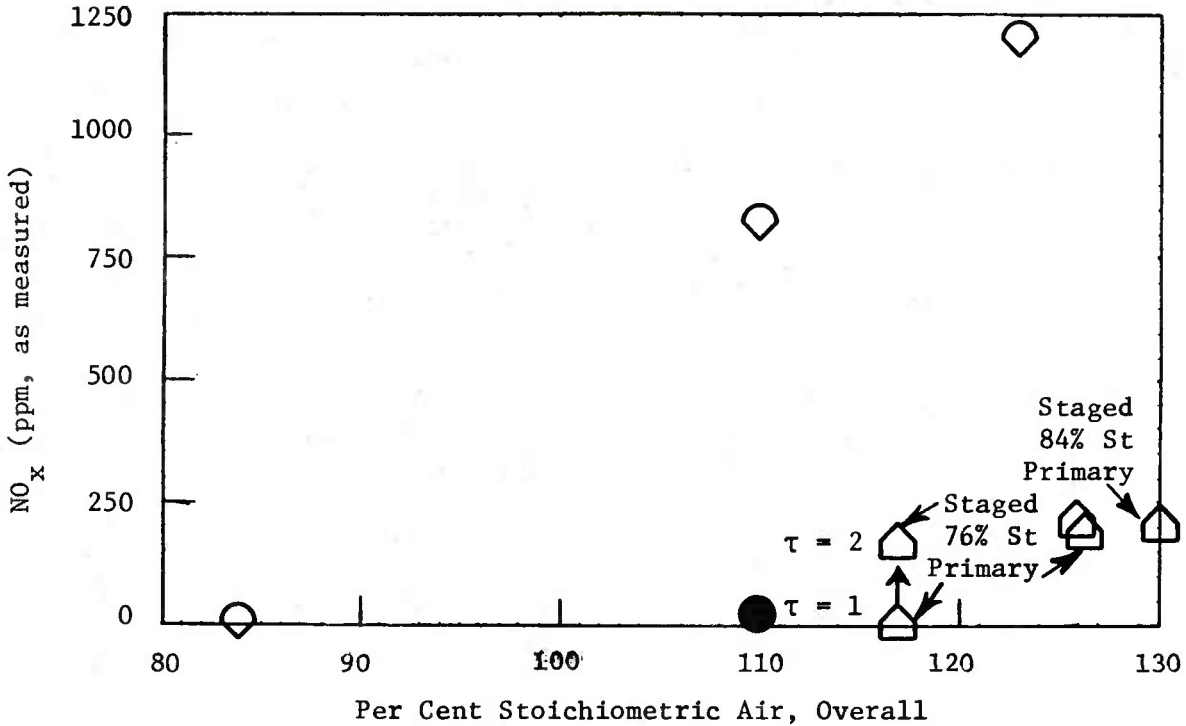

- Legend:
- - unstaged, no water injection
 - ◊ - unstaged, with ammonium nitrate injection
 - ◻ - staged, with ammonium nitrate injection

To check whether the poisoning was reversible, an additional run was made on the same catalytic bed material with propane and high sulfur fuel oil (Table 3-6). The results (Figures 3-9 and 3-10) indicated that the catalytic activity of the fluidized bed was not regenerated even after an hour and a half of running on a clean fuel (propane). NO_x reduction by staging was found to be about 60-65% with propane and with fuel oil using the poisoned catalytic fluid bed. This compares with better than 99% reduction using an active catalytic bed.

Run 106

<u>Fuel</u>	<u>Primary Zone Stoichiometry (When Staging)</u>	<u>Overall Stoichiometry</u>	<u>Ammonium Nitrate (20 wt %) Solution (lb/hr)</u>	<u>CO (ppm)</u>	<u>NO_x (ppm)</u>	<u>O₂ (pct)</u>	<u>Mid Fluid Bed Temp (°F)</u>	
Propane		112	0.	700	10	2.05	1740	
		112	4.7	700	800	2.35	1730	
		125	4.7	100	900	4.25	1710	
		85	4.7	>8000	0	0.4	1710	
		78	4.7	>8000	0	0.3	1720	
	78	117	4.7	200	320	2.85	1750	
		112	4.7	700	700	2.3	1650	
	78	126	4.7	100	360	4.0	1690	
	85	131	4.7	100	320	5.0	1660	
		112	0.	1100	20	1.9	1660	
	High-Sulfur Fuel Oil		115	0.	100	30	2.3	1760
			115	4.7	200	1250	2.6	1810
			128	4.7	100	1500	4.6	1810
		88	4.7	>8000	30	0.5	1780	
		79	4.7	>8000	0	0.35	1770	
79		117	4.7	200	420	1.85	1780	
	126	4.7	150	400	2.5	1780		
	131	4.7	100	580	3.9	1770		

Run 106

NO_x Concentration Vs. Overall Mixture Ratio
Catalytic Fluidized Bed
Using Propane Fuel

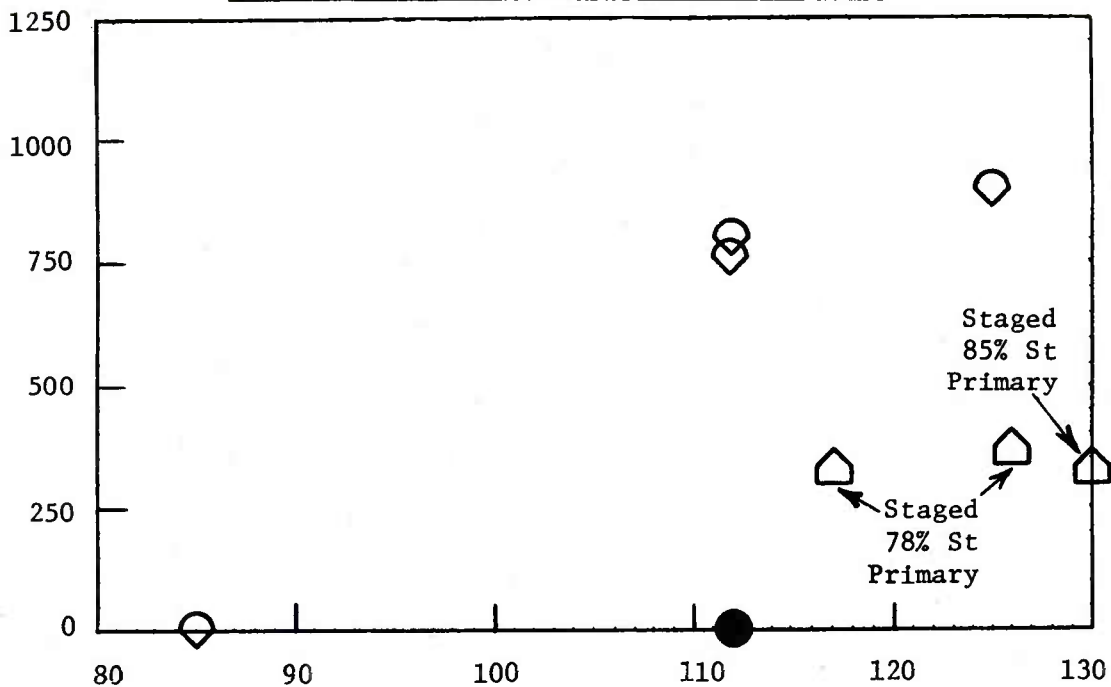

- Legend: ● - unstaged, no water injection
◊ - unstaged, with ammonium nitrate injection
△ - staged, with ammonium nitrate injection

Run 106

NO_x Concentration Vs. Overall Mixture Ratio
Catalytic Fluidized Bed
Using High Sulfur Fuel Oil

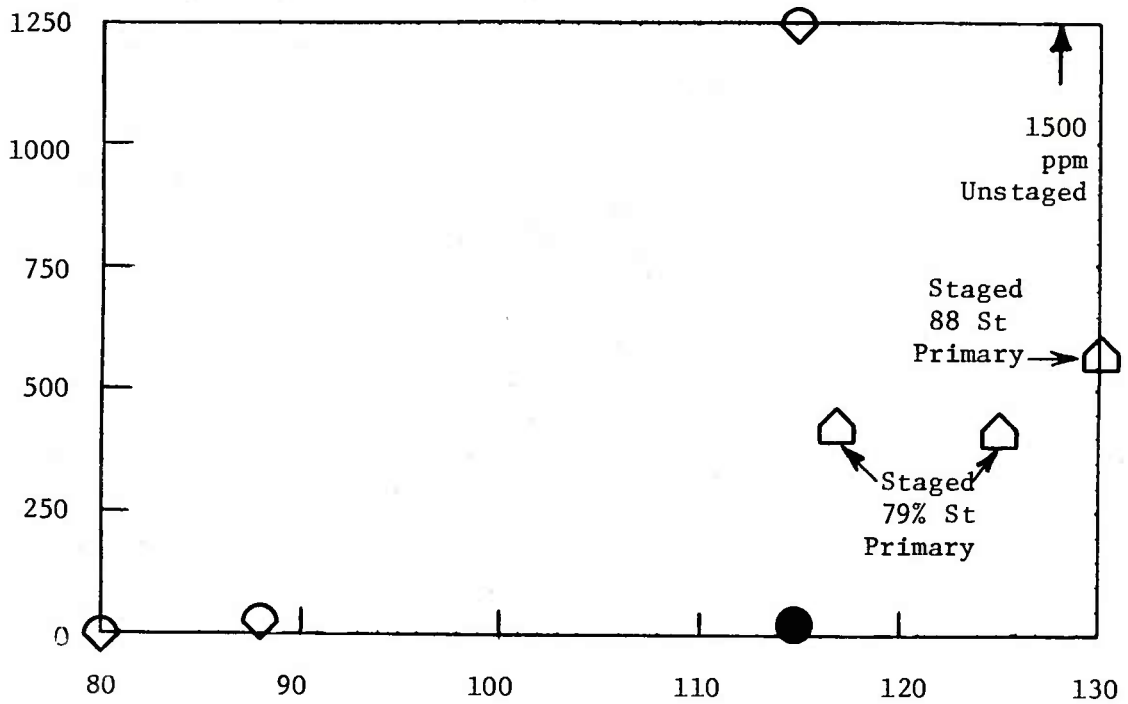

- Legend:
- - unstaged, no water injection
 - ◇ - unstaged, with ammonium nitrate injection
 - ⬠ - staged, with ammonium nitrate injection

The purpose of Run 107 was to further test the fixed catalytic bed concept in connection with the fluidized bed incinerator configuration. The bed material was replaced with fresh tabular alumina (non-catalytic) and fresh Girdler G-65 catalyst (7.7 lb) was installed in the basket. This was more than three times the amount used in Run 104. The NO_x reduction when staging were in the 75-80% range when compared with unstaged combustion (See Table 3-7 and Figure 3-11). Therefore, it was concluded that this particular configuration does not offer major advantages over staged non-catalytic incineration.

Run 107

Fuel	Primary Zone Stoichiometry (When Staging)	Overall Stoichiometry	Ammonium Nitrate (20 wt %) Solution (lb/hr)	CO (ppm)	NO _x (ppm)	O ₂ (pct)	Mid Fluid Bed Temp (°F)	Fixed Bed Temp (°F)
Propane		109	0.	2550	10	1.7	1730	1760
		109	4.7	1200	420	1.8	1770	1820
		122	4.7	200	700	3.7	1640	1800
		83	4.7	>8000	0	0.65	1650	1710
	75	117	4.7	650	150	3.1	1680	1610
	83	131	4.7	1150	120	5.0	1650	1640
	75	126	4.7	850	150	4.1	1660	1570
		75	4.7	>8000	10	0.6	1630	1680
High-Sulfur Fuel Oil		109	0.	600	30	2.1	1730	1620
		109	4.7	1300	1575	2.0	1750	1610
	75	117	4.7	6250	300	3.75	1720	1450

Run 107

NO_x Concentration Vs. Overall Mixture Ratio
Fixed Catalytic Bed Above Non-Catalytic Fluidized Bed
Propane and High Sulfur Oil

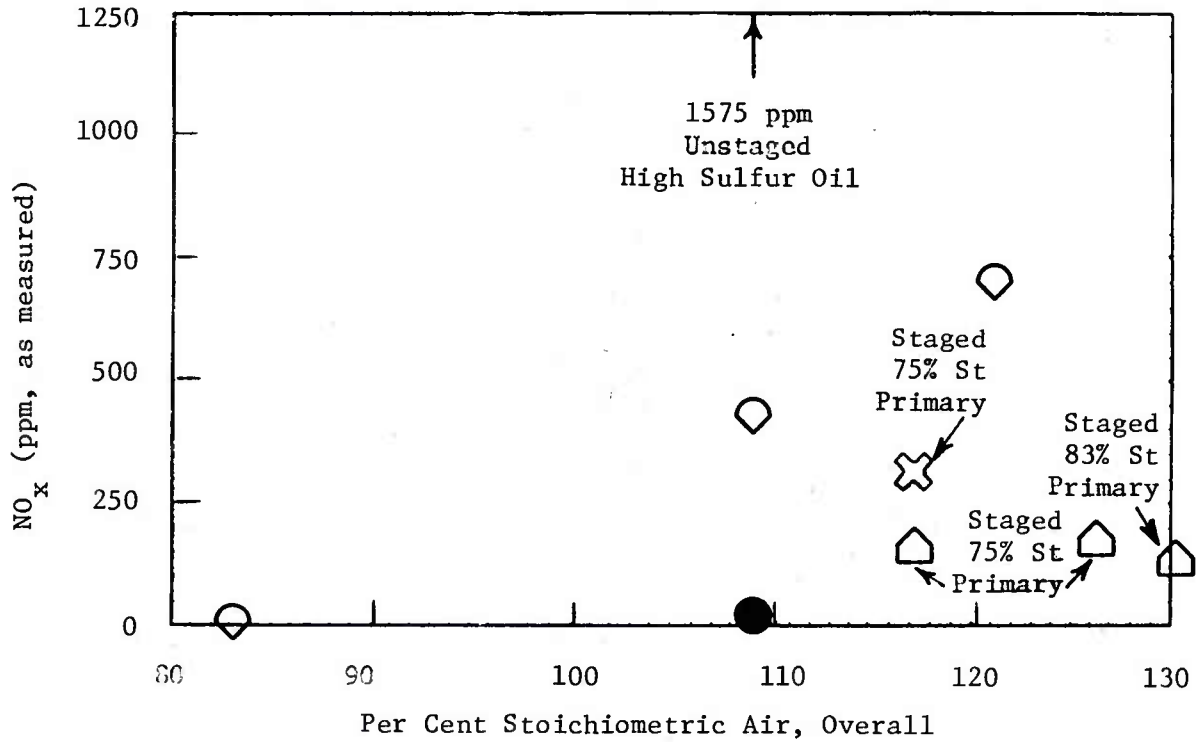

- Legend:
- - unstaged, no water injection
 - ◊ - unstaged, with ammonium nitrate injection
 - ◡ - staged, with ammonium nitrate injection
 - ⊗ - staged, with ammonium nitrate injection, high sulfur fuel oil

4. CONCLUSIONS AND RECOMMENDATIONS

As a result of the pilot scale experimental program conducted with the fluidized bed incinerator, the following conclusions were reached:

- Satisfactory operation of the catalytic fluidized bed incinerator on both gas and low sulfur fuel oil has been demonstrated. Stable combustion conditions with high sulfur fuel oil was demonstrated.
- The catalyst is rapidly poisoned when high sulfur fuel oil is used.
- Catalyst life was not determined for low sulfur fuel oil but satisfactory operation over several hours was demonstrated.
- A fixed catalytic bed separated from the fluidized non-catalytic bed was not found to be effective for NO_x reduction under the conditions tested.
- It is not known whether additional surface area, additional contact time, or different temperatures and mixture ratios would result in improved performance for the fixed catalytic bed.
- The burnout of partial combustion products in the fixed catalytic bed mode was not optimized.

Even though the initial results for a fixed catalyst bed for NO_x reduction in the incineration of nitrogen-containing waste materials were unfavorable, further work on the concept of using catalytic fluidized bed incineration for high sulfur fuels could be pursued. The following areas of investigation are recommended.

- Development of staged combustion technique with separate fixed catalytic bed (using low sulfur fuel).
 - Study effect of catalyst particle size
 - Study effect of catalyst bed temperature
 - Study effect of catalyst contact time
 - Study effect of primary zone mixture ratio
 - Study catalyst poisoning by sulfur compounds in this configuration
- Development of guard chamber concept
 - Study effectiveness of sulfur compound removal by dolomite under conditions suitable for catalytic reduction of NO_x
- Coupling guard chamber with fixed catalyst bed for NO_x reduction
 - Study catalyst life

APPENDIX F. EVALUATION RUN DATA

Table F-1. Complete set of data from Exxon Research & Engineering Co. monitoring (without catalyst)

Run no.	% H ₂	Disposal rate lb/hr	kg/hr	Primary air ft ³ /min	m ³ /sec	Secondary air ft ³ /min	m ³ /sec	In-bed fuel gal/min	m ³ /sec	Equivalence ratio ϕ	Grid Temp of °C	Bed Temp of °C	NO _x ppm	HC ppm	CO ppm	SO ₂ ppm	CO ₂ %				
1	water	0		3270	1.54	0	0	1.35	8.5	-	1340	727									
2	water	0		3270	1.54	0	0	.97	6.1	0.60	1390	754									
3	water	0		3270	1.54	0	0	.82	5.2	0.36	1350	732									
4	water	0		3270	1.54	0	0	.70	4.4	0.31	1325	718									
5	water	0		3270	1.54	0	0	.60	3.8	0.26	1300	704									
6	water	0		3270	1.54	0	0	1.20	7.6	0.53	1325	718									
7	water	0		3500	1.65	0	0	1.15	7.2	0.47	1430	777	954								
8	water	0		3000	1.41	0	0	0.75	4.7	0.36	1210	654	904								
9	water	0		2700	1.27	0	0	0.70	4.4	0.37	1210	654	916								
10	water	0		2200	1.03	0	0	0.75	4.7	0.49	1200	649	960								
11	water	0		2075	0.98	250	0.12	0.70	4.4	0.48	1240	671	1800								
12	water	0		2000	0.94	525	0.25	0.70	4.4	0.50	1240	671	1800								
13	water	0		1600	0.75	525	0.25	0.65	4.1	0.58	1230	666	1700								
14	water	0		2000	0.94	200	0.09	0.65	4.1	0.47	1215	657	1780								
15	water	0		1500	0.71	100	0.05	0.60	3.8	0.58	1210	654	1810								
16	water	0		1200	0.56	380	0.18	0.80	5.0	0.96	1150	621	1850								
17	water	0		3400	1.60	0	0	1.26	7.9	0.53	1140	616	1850								
18	water	0		1250	0.59	1000	0.47	0.90	5.7	1.04	625	330	1675								
Exxon monitoring																					
19	0	0		2500	1.18	0	0	1.00	6.3	0.58	1100	593	1900	1038	19	20	2	6.9	9.4		
20	15	170	77	2500	1.18	0	0	0.75	4.7	0.43	1100	593	1740	949	275	35	2	5.3	11.3		
21	15	170	77	1500	0.71	1000	0.47	0.85	5.4	0.02	900	482	1975	1080	1015	40	5	7.1	10.2		
22	15	170	77	2000	0.94	500	0.24	0.85	5.4	0.61	700	416	1790	977	511	495	4	6.4	10.2		
23	15	170	77	2400	1.13	0	0	0.85	5.4	0.51	1050	566	1850	1010	549	530	5	6.7	10.6		
24	15	170	77	2000	0.94	500	0.24	0.85	5.4	0.61	070	466	1750	954	423	405	32	5	5.3	12.1	
25	15	170	77	2400	1.13	0	0	0.73	4.6	0.44	910	488	1850	1010	705	674	32	9	6.4	11.6	
26	15	177	80	2400	1.13	0	0	0.73	4.6	0.44	610	321	1675	913	516	488	40	16	6.4	11.1	
27	15	177	80	1600	0.75	0	0	0.73	4.6	0.66	500	260	1350	732	420	407	110	48	7.0	9.7	
28	20	244	111	1900	0.89	1000	0.47	0.80	5.0	0.61	500	524	1700	954	678	664	80	10	6.3	10.8	
29	20	244	111	1200	0.56	1000	0.47	0.80	5.0	0.96	900	482	1700	927	1070	1054	70	9	6.4	10.8	
30	20	244	111	1200	0.56	500	0.24	0.80	5.0	0.96	825	440	1600	916	864	859	50	7	7.6	9.5	
31	20	244	111	800	0.38	400	0.19	0.80	5.0	1.45	0.67	500	399	1700	927	755	739	39	5	8.0	9.2
32	20	235	107	1300	0.61	0	0	0.40	2.5	0.45	875	469	1600	871	1625	1605	62	0	6.9	10.6	
33	20	235	107	1000	0.47	250	0.12	0.50	3.2	0.72	800	427	1550	843	1881	1663	78	8	6.5	10.6	
34	20	248	112	1000	0.47	500	0.24	0.65	4.1	0.87	660	349	1550	843	1202	859	80	7	6.4	10.4	
35	20	248	112	1000	0.47	750	0.35	0.67	4.2	1.01	650	343	1480	804	765	755	80	7	6.2	10.7	

Table F-2. Complete set of data from Scott Environmental Technology, Inc. monitoring (with and without catalyst)

Run no.	Disposal rate lb/hr	kg/hr	Primary air ft ³ /min	m ³ /sec	Secondary air ft ³ /min	m ³ /sec	In-bed fuel gal/min	m ³ /sec	Equivalence ratio ϕ_1	ϕ_2	Cold Temp of $^{\circ}$ C	Bed or $^{\circ}$ C	Temp $^{\circ}$ C	NO ppm	CO ppm	H ₂ C ppm	SO ₂ ppm	CO ₂ %	O ₂ %	
1	0	0	2400	1.13	0	0	0.70	4.41	0.46	0.0	1090	1060	1016	18	28	-	-	6.8	12.8	
2	0	0	1100	0.52	1000	0.47	0.70	4.41	1.01	0.52	1050	1790	977	16	78	-	-	5.2	15.0	
3	0	0	1300	0.61	500	0.24	0.70	4.41	0.05	0.62	1000	1790	977	20	<1	<1	<1	6.5	11.7	
4	0	0	2000	0.91	250	0.12	0.70	4.41	0.55	0.49	1000	1640	1004	21	<1	<1	<1	7.0	10.7	
5	15	177	80.3	1.13	0	0	0.73	4.69	0.48	-	1190	1990	1039	500	9	<1	<1	7.3	10.7	
6	15	177	80.3	1.13	250	0.12	0.70	4.41	0.46	0.42	925	1675	913	500	48	<1	<1	6.6	11.5	
7	15	177	80.3	1.13	500	0.24	0.75	4.70	0.63	0.49	900	1760	966	470	69	<1	<1	6.4	11.5	
8	15	177	80.3	1.13	1000	0.47	0.75	4.70	0.05	0.49	850	1625	895	390	120	<1	<1	5.6	13.1	
9	0	0	1600	0.75	500	0.24	0.65	4.10	0.64	0.49	960	1700	927	25	<1	<1	<1	6.5	11.3	
10	20	233	105.7	1.60	500	0.24	0.73	4.60	0.72	0.55	950	1825	996	490	23	<1	<1	6.6	11.5	
11	20	233	105.7	1.60	500	0.24	0.80	5.00	0.66	0.53	800	1650	899	280	32	<1	<1	6.7	11.3	
12	15	177	80.3	1.35	1000	0.47	0.95	6.00	1.11	0.64	800	1725	941	350	24	<1	<1	8.7	11.1	
13	15	177	80.3	1.60	500	0.24	0.95	5.40	0.84	0.64	760	1675	913	370	16	<1	<1	7.3	10.5	
catalyst added																				
14	15	177	80.3	1.30	0.61	0.12	0.65	4.10	0.79	0.66	1350	1780	971	800	17	<1	<1	4	7.1	11.3
15	15	177	80.3	1.40	0.66	0.24	0.75	4.70	0.85	0.63	1390	1690	871	570	17	<1	<1	4	6.7	11.3
16	15	177	80.3	0.90	0.38	1000	0.47	4.70	1.40	0.65	1275	1580	860	20	<1	<1	<1	4	5.4	13.5
16b	15	177	80.3	0.90	0.38	1000	0.47	4.70	1.48	0.65	-	-	200	52	<1	<1	<1	4	6.2	12.2
17	15	177	80.3	0.90	0.31	1000	0.47	4.50	1.72	0.68	1100	1590	871	16	1	<1	<1	7	6.1	12.0
18	15	177	80.3	0.90	0.31	1000	0.47	4.50	1.59	0.59	1199	1650	902	410	20	<1	<1	4	6.6	11.5
19	20	261	118.4	6.50	0.47	0.26	0.71	4.50	1.12	0.73	1020	1620	882	240	6	<1	<1	9	7.3	10.5
20	20	261	118.4	10.0	0.47	0.26	0.71	4.50	1.61	0.89	1000	1600	871	320	6	<1	<1	11	8.3	0.0
21	20	261	118.4	7.0	0.33	550	0.71	4.50	1.61	0.86	1000	1675	913	320	14	<1	<1	12	7.3	10.3
22	20	261	118.4	7.0	0.33	1000	0.47	4.50	1.36	0.86	1090	1600	871	270	59	<1	<1	8	6.2	11.3
23	20	261	118.4	7.0	0.33	1000	0.47	4.80	1.34	0.63	1030	1650	899	490	55	<1	<1	9	6.6	11.3
24	25	311	141.0	9.00	0.47	0.47	0.76	4.80	1.72	0.70	1025	1650	899	340	64	<1	<1	9	6.8	10.9
25	25	311	141.0	7.00	0.33	1000	0.47	4.80	2.01	0.75	1025	1575	858	350	55	<1	<1	9	7.1	10.4
26	25	320	145.0	6.00	0.28	1000	0.47	4.80	1.79	0.67	1000	1550	843	340	87	<1	<1	9	6.6	11.0
27	25	320	145.0	6.00	0.28	1000	0.47	4.80	1.79	0.67	950	1550	843	340	87	<1	<1	10	7.4	10.0
28	25	331	150.0	7.00	0.33	1000	0.47	4.59	1.63	0.74	950	1650	899	390	100	<1	<1	6	6.6	11.6
29	25	331	150.0	7.00	0.33	1000	0.47	4.80	2.16	0.74	960	1516	816	350	99	<1	<1	4	6.9	11.3

Table F-3. Complete set of data from USAEHA - first visit (with catalyst)

Run no.	Run % *	Disposal rate lb/hr	Primary air ft ³ /min	Secondary air ft ³ /min	In-bed fuel _{0-s} gal/min	Equivalence ratio		Grid temp °C	Bed temp °C	NO _x ppm	NO ppm	CO ppm	HC ppm	SO ₂ ppm	CO ₂ %	O ₂ %
						φ ₁	φ ₂									
1	water	-	900	0.42	1000	0.47	5.8	0.77	399	1650	899	-	-	-	-	-
2	water	-	900	0.42	1000	0.47	7.2	0.96	950	1600	871	-	-	-	-	-
3	water	-	900	0.42	1000	0.47	1.15	0.96	900	1650	899	-	-	-	4.7	14.6
4	5-B	58	26	0.42	1000	0.47	6.7	1.88	950	1700	927	-	-	-	6.0	15.0
5	15-B	177	80	0.38	1000	0.47	6.2	0.86	950	1650	899	-	-	-	5.3	14.8
6	15-B	177	80	0.38	1000	0.47	6.2	1.94	970	1725	941	360	0	0	4.2	17.4
7	25-B	312	142	0.09	1000	0.47	4.1	0.86	900	1500	816	402	0	0	2.7	17.4
8	20-B	325	147	0.28	1000	0.47	4.9	0.76	900	1490	810	436	0	0	2.9	19.4
9	15-B	240	109	0.19	1000	0.47	5.0	0.90	770	1450	788	288	0	0	2.6	16.8
10	15-B	240	109	0.24	1000	0.47	5.7	2.85	860	1700	927	215	0	0	2.4	16.1
11	15-B	240	109	0.24	1000	0.47	5.4	0.89	800	1650	899	187	0	0	3.2	14.8
12	25-B	416	189	0.24	1000	0.47	6.0	3.04	1000	1800	982	388	0	0	5.3	15.4
13	15-B	240	109	0.24	1000	0.47	6.6	3.32	1110	1700	927	185	0	0	4.8	15.6
14	5-B	77	35	0.24	1000	0.47	7.2	3.64	900	1800	982	173	0	0	4.8	15.3
15	25-T	456	207	0.24	1000	0.47	5.5	2.79	950	1600	871	336	0	0	4.2	15.7
16	15-T	240	109	0.24	1000	0.47	6.6	3.32	880	1700	927	295	0	0	3.9	15.6
17	5-T	77	35	0.24	1000	0.47	5.5	2.78	950	1650	899	280	0	0	3.5	16.0

*Explosives

B-Comp B
T-TNT

Table F-4. Complete set of data from USAEHA - second visit (with catalyst)

Run no.	Run % Comp B	Disposal rate lb/hr	Primary air ft ³ /min	Secondary air ft ³ /min	In-bed fuel _{0-s} gal/min	Equivalence ratio		Grid temp °C	Bed temp °C	NO _x ppm	NO ppm	CO ppm	HC ppm	SO ₂ ppm	CO ₂ %	O ₂ %	
						φ ₁	φ ₂										
1	25	454	206	0.85	1000	0.47	6.8	0.61	1150	621	843	330	0	16	33	5.8	18.2
2	25	454	206	0.85	1000	0.47	6.2	0.65	1150	621	938	444	0	10	29	6.8	17.3
3	25	454	206	0.61	1000	0.47	6.8	1.32	1270	688	927	500	0	9	23	7.9	16.9
4	25	454	206	0.28	1000	0.47	6.8	2.85	1300	704	1010	435	0	7	12	8.8	16.4
5	22	361	164	0.52	1000	0.47	7.1	1.61	1180	638	927	184	0	4	11	9.5	15.5
6	22	361	164	0.56	1000	0.47	6.8	1.42	1425	774	1010	294	0	6	12	9.8	15.8
7	15-20*	250*	113*	0.33	1000	0.47	5.4	1.92	1300	704	1066	192	0	106	--	13.9	18.3

*Approximate value - Unable to get sample of slurry to check density due to feed system problem

DISTRIBUTION LIST

Commander
US Army Armament Research and
Development Command
ATTN: DRDAR-CG
 DRDAR-LC (2)
 DRDAR-LCM
 DRDAR-LCM-S (30)
 DRDAR-LCP-F
 DRDAR-SC
 DRDAR-TSS (5)
 DRDAR-LCU-P
Dover, NJ 07801

Commander
US Army Materiel Development and
Readiness Command
ATTN: DRCDE-E
 DRCIS-E
 DRCPA-E
 DRCRPP-I
 DRCDL
 DRCSG-S
5001 Eisenhower Avenue
Alexandria, VA 22333

Commander
USDRC Installations & Services Agency
ATTN: DRCIS-RI-IU
 DRCIS-RI-IC
Rock Island, IL 61299

Department of the Army
Chief of Research, Development and Acquisition
Washington, DC 20310

Commander
US Army Armament Material
Readiness Command
ATTN: DRSAR-IR
 DRSAR-IRC (2)
 DRSAR-ISE (2)
 DRSAR-PDM
 DRSAR-ASF
 DRSAR-LC
 DRSAR-LEP-L
Rock Island, IL 61299

Project Manager for Munition Production
Base Modernization and Expansion
ATTN: DRCPM-PBM-EC
DRCPM-PBM-T-EV
Dover, NJ 07801

Director
US Army Industrial Base Engineering Activity
ATTN: DRXIB-MT
Rock Island, IL 61299

Department of the Army
Chief of Engineers
ATTN: DAEN-ZCE
Washington, DC 20310

Commander
ARRADCOM
ATTN: DRDAR-ACW
DRDAR-CLJ-L
DRDAR-TSB-S
DRDAR-CLT
Aberdeen Proving Ground, MD 21010

Defense Documentation Center
Cameron Station
Alexandria, VA 22314 (12)

Commander
Mobility Equipment R&D Command
ATTN: DRDME-GS
Ft. Belvoir, VA 22060

Commander
US Army Construction Engineering
Research Laboratory
ATTN: CERL-ER
Champaign, IL 61820

US Army Engineer District, New York
ATTN: Construction District
26 Federal Plaza
New York, NY 10007

Commander
ARRADCOM
ATTN: DRDAR-LCB-TL
Watervliet, NY 12189

US Army Engineer District, Baltimore
ATTN: Construction Division
PO Box 1715
Baltimore, MD 21203

US Army Engineer District, Norfolk
ATTN: Construction Division
803 Front Street
Norfolk, VA 23510

US Army Engineer District, Mobile
ATTN: Construction Division
PO Box 2288
Mobile, AL 36628

U Army Engineer District, Fort Worth
ATTN: Construction Division
PO Box 17300
Fort Worth, TX 76102

US Army Engineer District, Omaha
ATTN: Construction Division
6014 USPO and Courthouse
215 North 17th Street
Omaha, NE 68102

US Army Engineer District, Kansas City
ATTN: Construction Division
700 Federal Building
Kansas City, MO 64106

US Army Engineer District, Sacramento
ATTN: Construction Division
650 Capital Mall
Sacramento, CA 95814

US Army Engineer District, Huntsville
ATTN: Construction Division
PO Box 1600 West Station
Huntsville, AL 35807

Commander
US Army Environmental Hygiene Agency
ATTN: HSE-E (2)
Aberdeen Proving Ground, MD 21010

Commander
Badger Army Ammunition Plant
ATTN: SARBA-CE
Baraboo, WI 53913

Commander
Cornhusker Army Ammunition Plant
ATTN: SARCO-E
Grand Island, NB 68801

Commander
Holston Army Ammunition Plant
ATTN: SARHO-E
Kingsport, TN 37662

Commander
Indiana Army Ammunition Plant
ATTN: SARIN-OR
Charlestown, IN 47111

Commander
Naval Weapons Support Center
ATTN: Code 5042, Mr. C.W.Gilliam
Crane, IN 47522

Commander
Iowa Army Ammunition Plant
ATTN: SARIO-A
Middletown, IA 52638

Commander
Joliet Army Ammunition Plant
ATTN: SARJO-SS-E
Joliet, IL 60436

Commander
Kansas Army Ammunition Plant
ATTN: SARKA-CE
Parsons, KS 67537

Commander
Lone Star Army Ammunition Plant
ATTN: SARLS-IE
Texarkana, TX 57701

Commander
Longhorn Army Ammunition Plant
ATTN: SARLO-O
Marshall, TX 75670

Commander
Louisiana Army Ammunition Plant
ATTN: SARLA-S
Shreveport, LA 71102

Commander
Milan Army Ammunition Plant
ATTN: SARMI-EM
Milan, TN 38358

Commander
Newport Army Ammunition Plant
ATTN: SARNE-S
Newport, IN 47966

Commander
Pine Bluff Arsenal
ATTN: SARPB-ETA
Pine Bluff, AR 71601

Commander
Radford Army Ammunition Plant
ATTN: SARRA-IE
Radford, VA 24141

Commander
Ravenna Army Ammunition Plant
Ravenna, OH 44266

Commander
Sunflower Army Ammunition Plant
ATTN: SARSU-0
Lawrence, KS 66044

Commander
Volunteer Army Ammunition Plant
ATTN: SARVO-T
Chattanooga, TN 34701

Army Logistics Management Center
Environmental Management
ATTN: Mr. Otto Nauman
Fort Lee, VA 23801 (2)

Project Manager for Chemical Demilitarization
and Installation Restoration
ATTN: DRCPM-DRR, Mr. Harry Sholk
Aberdeen Proving Ground, MD 21010

US Environmental Protection Agency
Office of Solid Waste Management Programs
Washington, DC 20460

Department of the Army
ATTN: Chief of Engineers
DAEN-MCZ-A
DAEN-FEZ-A
DAEN-CWZ-A
DAEN-REZ-A
Washington, DC 20304

US Environmental Protection Agency
National Environmental Research Center
Edison Water Quality Research Laboratory
Industrial Waste Technology Branch
Edison, NJ 08817

Dr. John A. Brown
PO Box 145
Berkeley Heights, NJ 07922

Commander
Naval Surface Weapons Center
ATTN: WR-21-T. Sullivan
Indian Head, MD 20640

Commander
Tooele Army Depot
ATTN: Ammo Equipment Ofc, F. Crist
Tooele, UT 84074

Commander
Naval Ammunition Depot
Hawthorne, NV 89415

Commander
DARCOM Ammunition Center
ATTN: DRXAC-DEV, J. Byrd
Savanna, IL 61074

Weapon System Concept Team/CSL
ATTN: DRDAR-ACW
Aberdeen Proving Ground, MD 21010

US Army Materiel/Systems Analysis Activity
ATTN: DRXSY-MP
Aberdeen Proving Ground, MD 21005