

AD-A064 287

AERONAUTICAL RESEARCH ASSOCIATES OF PRINCETON INC N J F/G 1/3  
GUST LOAD ESTIMATION USING A SIMPLIFIED POWER SPECTRAL TECHNIQU--ETC(U)  
OCT 78 G G WILLIAMSON DOT-FA77WA-3972

UNCLASSIFIED

ARAP-362

FAA/RD-78/118

NL

1 OF 1  
AD  
A064 287

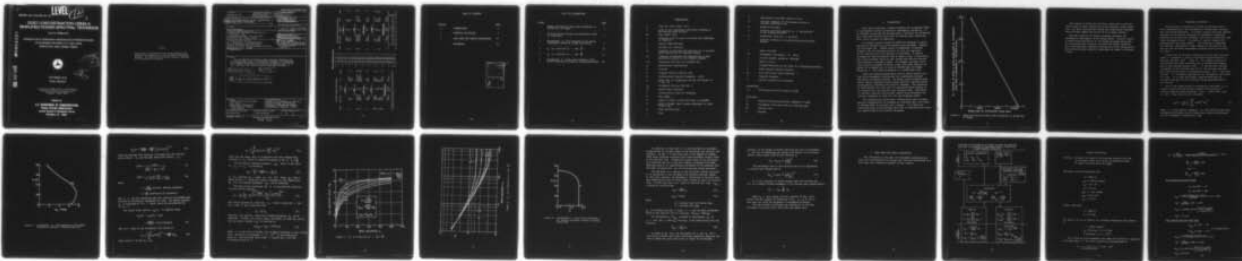

END  
DATE  
FILMED

4 --79  
DDC

2

**LEVEL** (12)

REPORT NO. FAA-RD-78-118

# GUST LOAD ESTIMATION USING A SIMPLIFIED POWER SPECTRAL TECHNIQUE

Guy G. Williamson

AERONAUTICAL RESEARCH ASSOCIATES OF PRINCETON, INC.  
50 WASHINGTON ROAD, P.O. BOX 2229  
PRINCETON, NEW JERSEY 08540

ADA 064287

DDC FILE COPY



OCTOBER 1978  
FINAL REPORT

Document is available to the U.S. public through the National Technical Information Service, Springfield, Virginia 22161.

Prepared for  
**U.S. DEPARTMENT OF TRANSPORTATION**  
FEDERAL AVIATION ADMINISTRATION  
Systems Research & Development Service  
Washington, D.C. 20590

79 02 02 058

NOTICE

This document is disseminated under the sponsorship of the Department of Transportation in the interest of information exchange. The United States Government assumes no liability for its contents or use thereof.

1. Report No. FAA-RD-78-118		2. Government Accession No. 18 FAA/RD / 19		3. Recipient's Catalog No. 19 78/448	
4. Title and Subtitle 6 GUST LOAD ESTIMATION USING A SIMPLIFIED POWER SPECTRAL TECHNIQUE.		5. Report Date 11 October 1978		6. Performing Organization Code	
7. Author(s) Guy Williamson		8. Performing Organization Report No. A.R.A.P. Report No. 362		9. Work Unit No. (TRAIS)	
9. Performing Organization Name and Address Aeronautical Research Associates of Princeton, Inc. 50 Washington Road, P.O. Box 2229 Princeton, New Jersey 08540		10. Contract or Grant No. 13 DOT-FA77WA-3972		11. Type of Report and Period Covered 9 Final Report April 1977-April 1978	
12. Sponsoring Agency Name and Address U.S. Department of Transportation Federal Aviation Administration Systems Research and Development Services Washington, D.C. 20590		13. Sponsoring Agency Code ALG-313		14. Supplementary Notes	
16. Abstract A one-degree-of-freedom power spectral technique for estimating gust loads on aerodynamic surfaces is presented. A procedural flowchart to guide the designer in the use of this technique and sample calculations are included. 14 ARAP-362   12 27 p.   10 Guy G. Williamson					
17. Key Words General Aviation Aircraft Gust Loads Atmospheric Turbulence Power Spectral Density Application			18. Distribution Statement Document is available to the U.S. public through the National Technical Information Service, Springfield, Virginia 22161.		
19. Security Classif. (of this report) Unclassified		20. Security Classif. (of this page) Unclassified		21. No. of Pages 24	22. Price

elt

# METRIC CONVERSION FACTORS

## Approximate Conversions to Metric Measures

Symbol	When You Know	Multiply by	To Find	Symbol
<b>LENGTH</b>				
in	inches	2.5	centimeters	cm
ft	feet	30	centimeters	cm
yd	yards	0.9	meters	m
mi	miles	1.6	kilometers	km
<b>AREA</b>				
m <sup>2</sup>	square inches	6.5	square centimeters	cm <sup>2</sup>
ft <sup>2</sup>	square feet	0.09	square meters	m <sup>2</sup>
yd <sup>2</sup>	square yards	0.8	square meters	m <sup>2</sup>
mi <sup>2</sup>	square miles	2.6	square kilometers	km <sup>2</sup>
	acres	0.4	hectares	ha
<b>MASS (weight)</b>				
oz	ounces	28	grams	g
lb	pounds	0.45	kilograms	kg
	short tons (2000 lb)	0.9	tonnes	t
<b>VOLUME</b>				
tsp	teaspoons	5	milliliters	ml
Tbsp	tablespoons	15	milliliters	ml
fl oz	fluid ounces	30	milliliters	ml
c	cups	0.24	liters	l
pt	pints	0.47	liters	l
qt	quarts	0.95	liters	l
gal	gallons	3.8	liters	l
ft <sup>3</sup>	cubic feet	0.03	cubic meters	m <sup>3</sup>
yd <sup>3</sup>	cubic yards	0.76	cubic meters	m <sup>3</sup>
<b>TEMPERATURE (exact)</b>				
°F	Fahrenheit temperature	5/9 (after subtracting 32)	Celsius temperature	°C

## Approximate Conversions from Metric Measures

Symbol	When You Know	Multiply by	To Find	Symbol
<b>LENGTH</b>				
mm	millimeters	0.04	inches	in
cm	centimeters	0.4	inches	in
m	meters	3.3	feet	ft
m	meters	1.1	yards	yd
km	kilometers	0.6	miles	mi
<b>AREA</b>				
cm <sup>2</sup>	square centimeters	0.16	square inches	in <sup>2</sup>
m <sup>2</sup>	square meters	1.2	square yards	yd <sup>2</sup>
km <sup>2</sup>	square kilometers	0.4	square miles	mi <sup>2</sup>
ha	hectares (10,000 m <sup>2</sup> )	2.5	acres	acres
<b>MASS (weight)</b>				
g	grams	0.035	ounces	oz
kg	kilograms	2.2	pounds	lb
t	tonnes (1000 kg)	1.1	short tons	short tons
<b>VOLUME</b>				
ml	milliliters	0.03	fluid ounces	fl oz
l	liters	2.1	pints	pt
l	liters	1.06	quarts	qt
l	liters	0.26	gallons	gal
m <sup>3</sup>	cubic meters	35	cubic feet	ft <sup>3</sup>
m <sup>3</sup>	cubic meters	1.3	cubic yards	yd <sup>3</sup>
<b>TEMPERATURE (exact)</b>				
°C	Celsius temperature	9/5 (then add 32)	Fahrenheit temperature	°F

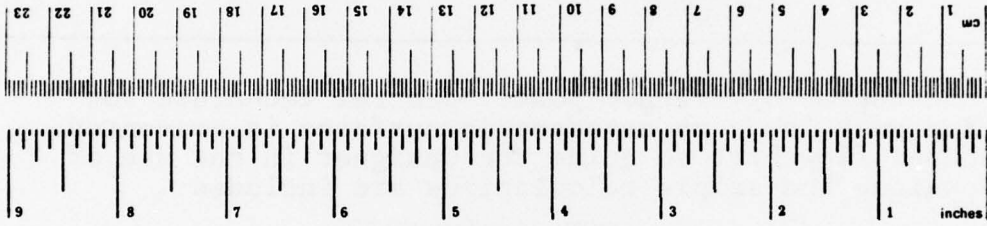

\* 1 in. = 2.54 (exact). For other exact conversions and more detailed tables, see NBS Misc. Publ. 286, Units of Weights and Measures, Price \$2.25, SD Data 36, No. C13-10-286.

TABLE OF CONTENTS

SECTION		PAGE
1	INTRODUCTION	1
2	TECHNICAL DISCUSSION	4
3	FLOW CHART AND SAMPLE CALCULATIONS	15
	REFERENCES	19

ACCESSION for	
NTIS	Write Section <input checked="" type="checkbox"/>
DDC	5 of Section <input type="checkbox"/>
UNCLASSIFIED	<input type="checkbox"/>
JURISDICTION	
BY	
DISTRIBUTION AVAILABILITY CODES	
SPECIAL	
A	

## LIST OF ILLUSTRATIONS

FIGURE		PAGE
1	Sample histogram of wing load exceedances in 30,000 hrs. of flight	2
2	Aircraft flying through one-dimensional field of turbulence	5
3	Recommended $\sigma_w$ from reference 9 for severe turbulence (storms or strong convection)	7
4	$K_\phi$ as a function of $\mu$ and $\frac{2L}{c}$	10
5	$k_o$ as a function of $\mu$ and $\frac{2L}{c}$	11
6	Recommended P values from reference 9 for severe turbulence (storms or strong convection)	12

## NOMENCLATURE

a	wing lift curve slope $\partial L/\partial \alpha$
A	ratio of rms incremental load factor response to rms vertical gust velocity
AR	wing aspect ratio
c	reference chord of wing or vertical tail depending on subscript
e	natural logarithm base
f	unsteady lift function
$f_1$	component of unsteady lift function due to aircraft motion defined in the frequency domain
$f_2$	component of unsteady lift function due to gust penetration defined in the frequency domain
F,G	Theodorsen functions for unsteady lift
g	gravitational acceleration
h	altitude
H	transfer function (see Eq. (6))
k	nondimensional temporal frequency, $\omega c/2U$
$k_c$	upper limit of integration for the calculation of A and $N_o$
$k_o$	exceedance function from Ref. 1
ln	natural base logarithm
L	characteristic scale of turbulence
M	Mach number
N	number of times a given load level is exceeded
P	ratio of flight time in heavy turbulence to total flight time
S	wing reference area
t	time

U mean speed of aircraft relative to air  
 w vertical component of fluctuating velocity of aircraft relative to air  
 W weight of aircraft  
 x position coordinate parallel to U and positive in the forward direction  
 X integration limit for x position  
 z position coordinate in vertical direction positive upwards  
  
 $\alpha$  angle of attack  
 $\Delta n$  incremental load factor  $\sim (L - W)/g$   
 $\mu$  aircraft density parameter  $2W/apcgS$   
 $\rho$  density of air  
 $\sigma$  standard deviation or rms value of a fluctuating function  
 $\phi$  power spectral density function  
 $k_{\phi}$  gust alleviation factor from Ref. 1  
 $\omega$  temporal frequency  
 $\Omega$  spatial frequency of turbulence

#### Superscript

( $\cdot$ ) differentiation with respect to time

#### Subscripts

w vertical fluctuating velocity component or wing  
 $\Delta n$  incremental load factor due to a vertical gust  
 VT vertical tail  
 d desired

## 1. INTRODUCTION

This report describes a simple technique for estimating loads on aerodynamic surfaces produced by atmospheric turbulence. It is intended to provide the designer with a technique for estimating gust loads more realistically than the discrete gust method and with little increase in complexity.

At present, aircraft covered by FAR23 are designed to safely encounter a discrete gust with specific size and shape. However, the continuous and random nature of atmospheric turbulence suggests that the designer consider not only the magnitude of the load but also its frequency of occurrence. A typical histogram of load exceedances such as shown in Fig. 1 would allow for a more rational choice of gust design load and also provide data relevant to fatigue studies. For example, aircraft structures could be designed to handle a gust load level which is expected to be exceeded only 10 times in 30,000 hours of flight. Using Fig. 1, this would correspond to a 10,000 pound load.

There are several methods which can be used to predict the load level exceedance distribution for a particular aircraft and series of mission profiles. Estimates can be obtained using either time or frequency domain (power spectral) representations of atmospheric turbulence and aircraft response. The complexity of these methods and their ease of application depend mainly on the complexity of the aircraft gust response model. References 1-7 develop, describe and evaluate several load exceedance calculation techniques in both the time and frequency domain.

This design guide illustrates a method which uses the power spectral representation of atmospheric turbulence and a one degree of freedom model of aircraft gust response. It is easily accomplished using several design charts and is therefore well within the capabilities of all aircraft designers.

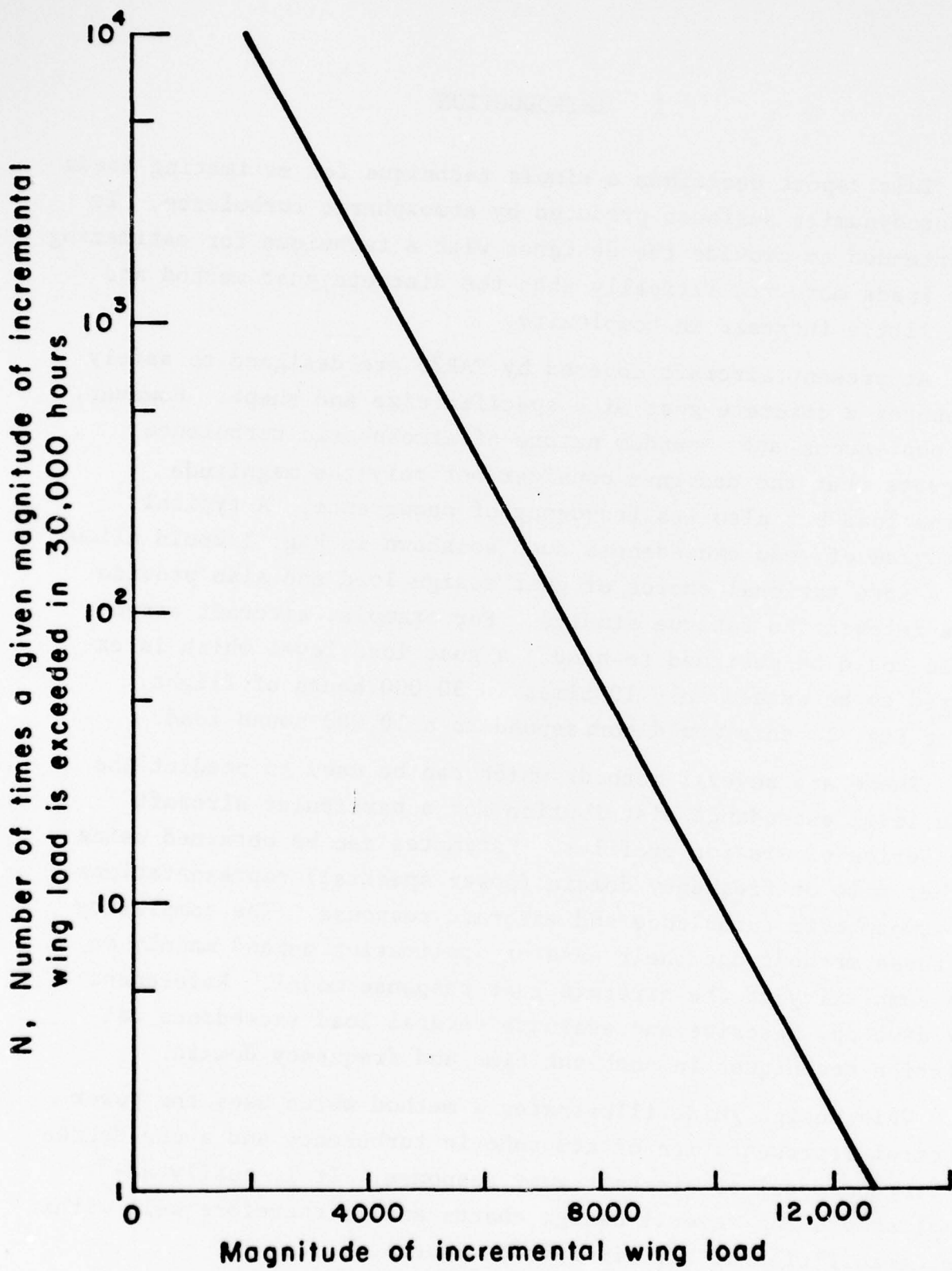

Figure 1. Sample histogram of wing load exceedances in 30,000 hrs. of flight

The methods outlined here should be restricted to use with fairly rigid aircraft flying well below transonic flight speeds. Also, the small perturbation lateral and longitudinal responses should be well damped and should not be strongly coupled.

Section 2 details the design technique and gives the mathematical development of the design charts. Section 3 gives a step-by-step description of the design procedure along with an illustration for a specific aircraft and flight condition. For a more detailed comparative evaluation of this design procedure and other power spectral techniques the reader is referred to Ref. 7.

## 2. TECHNICAL DISCUSSION

This section is intended to provide the designer with a basic understanding of the one-degree-of-freedom power spectral gust load design procedure. It briefly reviews the power spectral approach to the problem, modeling the atmospheric turbulence, modeling the aircraft gust response, and finally determining load level exceedance curves. No attempt is made to compare this technique with any other method. The technique is developed for specific application to gust loading of the wing but can also be used for other aerodynamic surfaces as will be pointed out later.

Assume that an aircraft flying straight and level with air-speed  $U$  encounters a patch of turbulence characterized by a vertical velocity  $w(x)$  (Fig. 2). The forward velocity of the aircraft will make traversing the turbulence patch appear like a time-varying velocity  $w(t)$ . If the vertical velocity is upwards it will increase the lift on the aircraft wing and will cause the aircraft to accelerate upwards,  $\ddot{z}(t)$ . The acceleration  $\ddot{z}$  is usually expressed as the incremental load factor  $\Delta n = \ddot{z}/g$ . It is this load factor response which must be estimated and used in the structural design specifications of the aircraft.

Due to the random nature of atmospheric turbulence, it is easier to work with the spatial frequency distribution of vertical velocity (Power Spectrum)  $\phi_w(\Omega)$ , rather than  $w(x)$  or  $w(t)$ . These functions are related by

$$\phi_w(\Omega) = \lim_{X \rightarrow \infty} \frac{1}{X} \left| \int_{-X/2}^{X/2} w(x) e^{i\Omega x} dx \right|^2 \quad (1)$$

where  $\Omega$  is the spatial frequency. For this and most gust load estimation techniques, the Von Karman power spectral representation of atmospheric turbulence is used

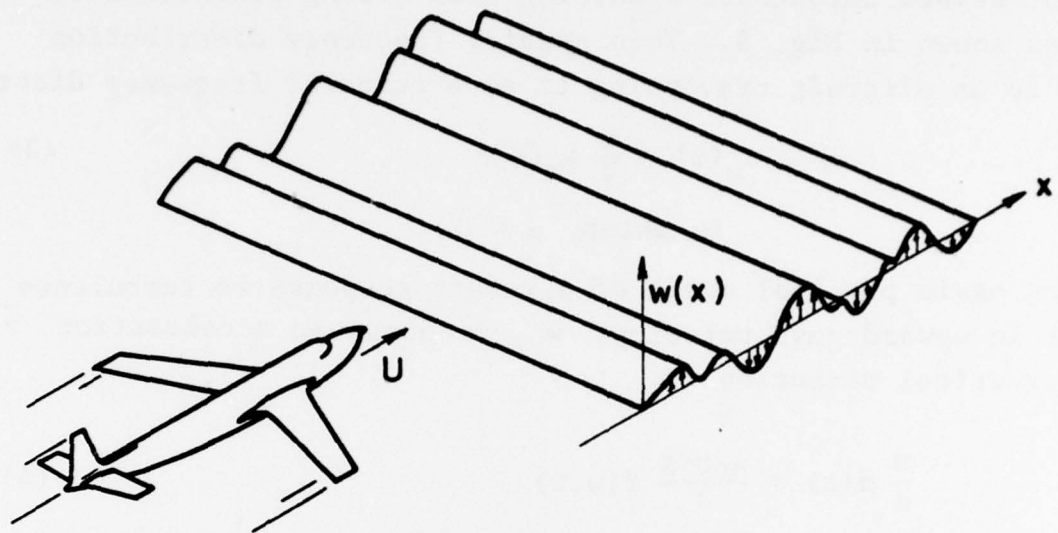

Figure 2. Aircraft flying through one-dimensional field of turbulence

$$\phi_w(L\Omega) = \frac{\sigma_w^2}{\pi} \frac{1 + \frac{8}{3} (1.339L\Omega)^2}{[1 + (1.339L\Omega)^2]^{11/6}} \quad (2)$$

where  $\sigma_w$  is the root mean square turbulent velocity and  $L$  is the scale of turbulence. Reference 1 recommends that a value of  $L = 750$  ft be used for design purposes. Reference 9 recommends  $\sigma_w(h)$  for severe turbulence resulting from strong convection or storms as shown in Fig. 3. This spatial frequency distribution appears to an aircraft traversing it as a temporal frequency distribution.

$$\phi_w(\omega) = \frac{L}{U} \phi_w(L\Omega) \quad (3)$$

in which  $\omega = U\Omega$

The basic physical model of aircraft response to turbulence is that an upward gust velocity,  $w$ , produces an acceleration,  $\ddot{z}$  in the vertical direction.

$$\frac{W}{g} \ddot{z}(t) = \frac{a\rho U^2 S}{2} f(w, t) \quad (4)$$

where

$W$  = aircraft weight

$g$  = gravitational constant

$a$  = wing lift curve slope

$\rho$  = density of air

$U$  = mean airspeed

$S$  = wing reference area

$f(w, t)$  = unsteady lift function

Expressing the normal acceleration as incremental load factor  $\Delta n$

$$\Delta n(t) = \frac{\ddot{z}(t)}{g} = \frac{a\rho U^2 S}{2W} f(w, t) \quad (5)$$

This equation is transformed into the frequency domain and expressed in transfer function form

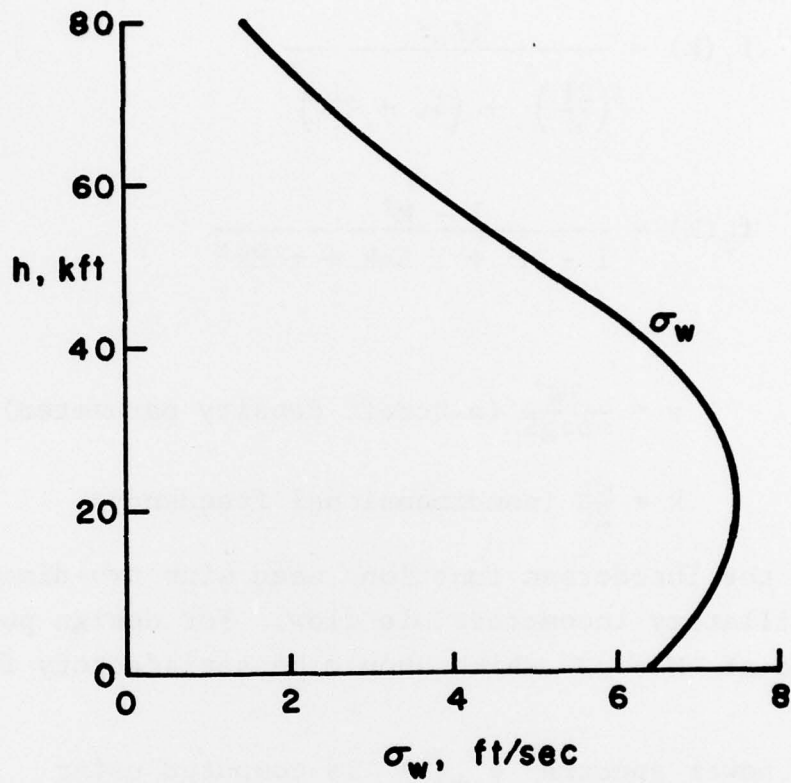

Figure 3. Recommended  $\sigma_w$  from reference 9 for severe turbulence (storms or strong convection)

$$H_{\Delta n}(k) = \frac{\Delta n(k)}{w(k)} = \frac{a\rho US}{2W} \left[ f_1(k) f_2(k) \right]^{1/2} \quad (6)$$

where the unsteady lift function is divided into the aircraft motion effect,  $f_1$ , and the gust penetration effect,  $f_2$ .

$$f_1(k) = \frac{16\mu^2}{\left(\frac{2F}{k}\right)^2 + \left(4\mu + \frac{2G}{k}\right)^2} \quad (7)$$

$$f_2(k) = \frac{1 - M^2}{1 - M^2 + 1.5\pi k + \pi^2 M k^2} \quad (8)$$

where

$$\mu = \frac{2W}{a\rho c g S} \text{ (aircraft density parameter)}$$

$$k = \frac{\omega c}{2U} \text{ (nondimensional frequency)}$$

and  $F$ ,  $G$  are the Theodorsen functions used with two-dimensional airfoils in oscillatory incompressible flow. For design purposes  $f_2$  is evaluated at  $M = .2$  which should be satisfactory for  $0 \leq M \leq .5$ .

The output power spectra  $\phi_{\Delta n}(k)$  is computed using

$$\begin{aligned} \phi_{\Delta n}(k) &= |H_{\Delta n}(k)|^2 \phi_w(k) \\ &= \left(\frac{a\rho SU}{2W}\right)^2 f_1(k) f_2(k) \phi_w(k) \end{aligned} \quad (9)$$

The r.m.s. value of the incremental load factor is

$$\sigma_{\Delta n} = \left[ \int_0^{\infty} \phi_{\Delta n}(k) dk \right]^{1/2} = \frac{a\rho SU}{2W} K_{\phi} \sigma_w \quad (10)$$

where from Eq. (9) and Eq. (10)

$$K_{\phi} = \left[ \int_0^{k_c} f_1(k) f_2(k) \frac{\phi_w(k)}{\sigma_w^2} dk \right]^{1/2} \quad (11)$$

Note that the upper limit of integration has been changed from infinity to  $k_c$  which for numerical purpose is set to  $k_c = \frac{\pi}{AR}$

The structural response parameter,  $A_{\Delta n}$ , which is the ratio of  $\sigma_{\Delta n}$  to  $\sigma_w$ , is therefore

$$A_{\Delta n} = \frac{\sigma_{\Delta n}}{\sigma_w} = \frac{a_p S U}{2W} K_{\phi} = \frac{U}{\mu c g} K_{\phi} \quad (12)$$

$K_{\phi}$  is a function of  $\mu$  (from  $f_1$ ) and  $2L/c$  (from  $\phi_w$ ) and is shown in Fig. 4. Using the results contained in this figure plus Eq. (12) the response parameter  $A_{\Delta n}$  can be evaluated.

The rate of zero crossings for  $\Delta n$  in the positive direction is given by the relation

$$N_o = \frac{1}{2\pi} \frac{\sigma_{\Delta n}}{\sigma_{\Delta n}} = \frac{1}{2\pi} \frac{\left[ \int_0^{k_c} \left( \frac{2Uk}{c} \right)^2 |H_{\Delta n}|^2 \phi_w(k) dk \right]^{1/2}}{\sigma_{\Delta n}} \quad (13)$$

This can be written as a function,  $k_o$ , which is given by  $\mu$  and  $2L/c$  (Fig. 5) and a velocity term

$$N_o = \frac{U}{\pi c} k_o \quad (14)$$

Using Eq. (13) and Fig. 5 the zero crossing parameter  $N_o$  can be evaluated. Finally, for severe loads, the number of times per second that any given loading  $\Delta n_d$  is exceeded is

$$N(\Delta n_d) = P N_o e^{-\Delta n_d / A_{\Delta n} \sigma_w} \quad (15)$$

where  $P$  is the ratio of flight time in severe turbulence to total flight time. Reference 9 recommends  $P = 5 \times 10^{-4}$  at altitudes below 40000 ft. For altitudes above 40000 ft consult Fig. 6 for the recommended value of  $P$ .

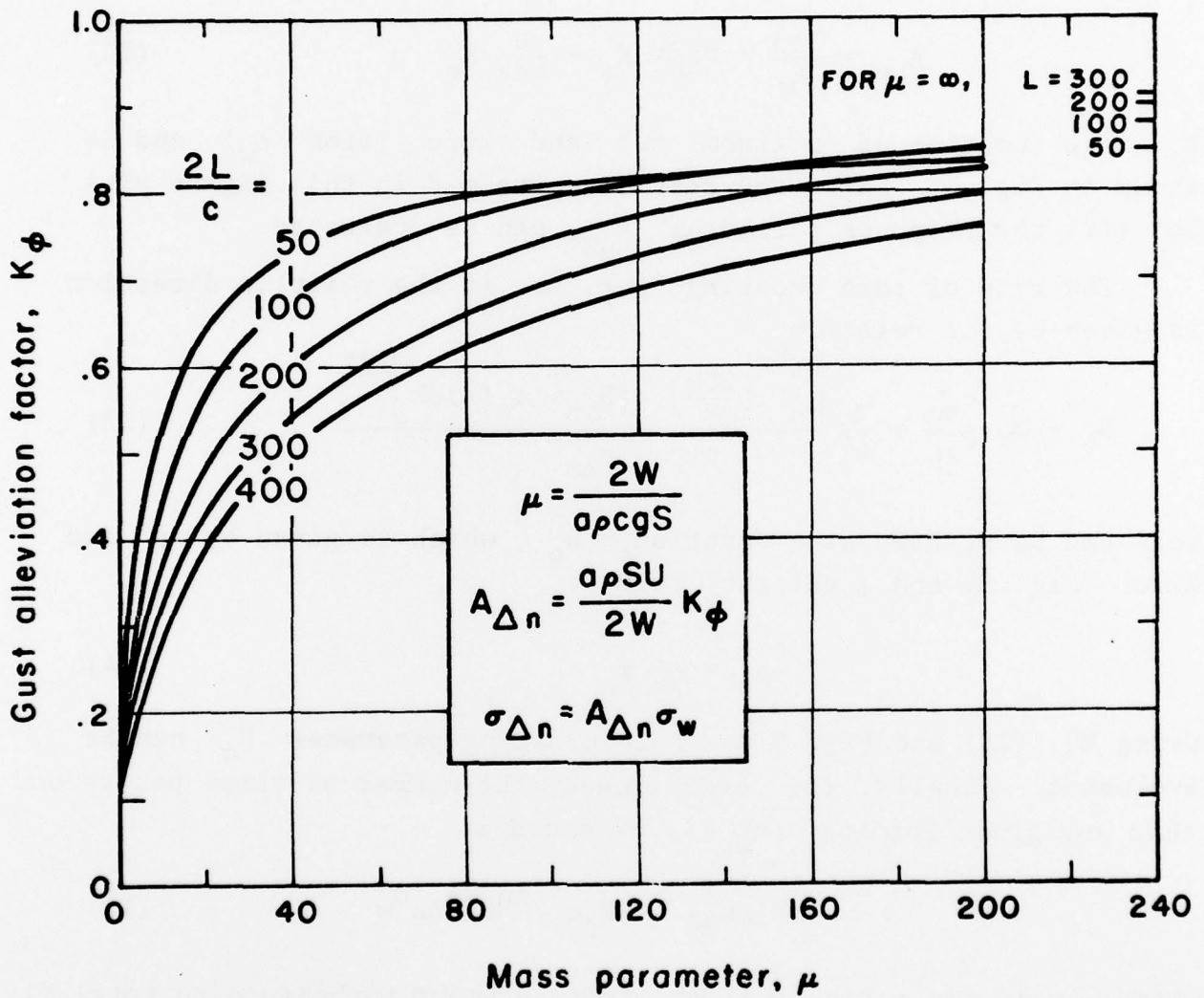

Figure 4.  $K_{\phi}$  as a function of  $\mu$  and  $\frac{2L}{c}$

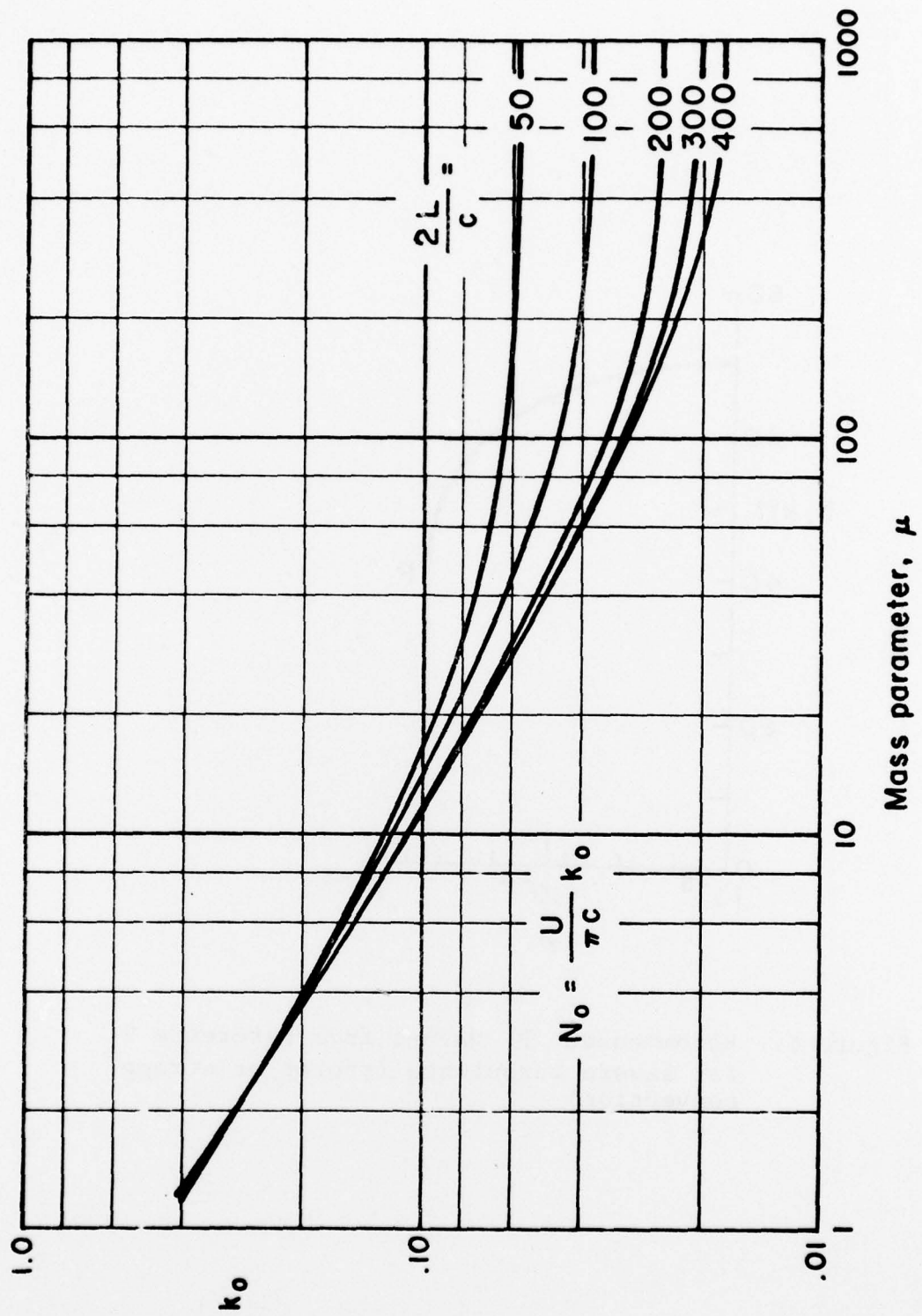

Figure 5.  $k_0$  as a function of  $\mu$  and  $\frac{2L}{c}$

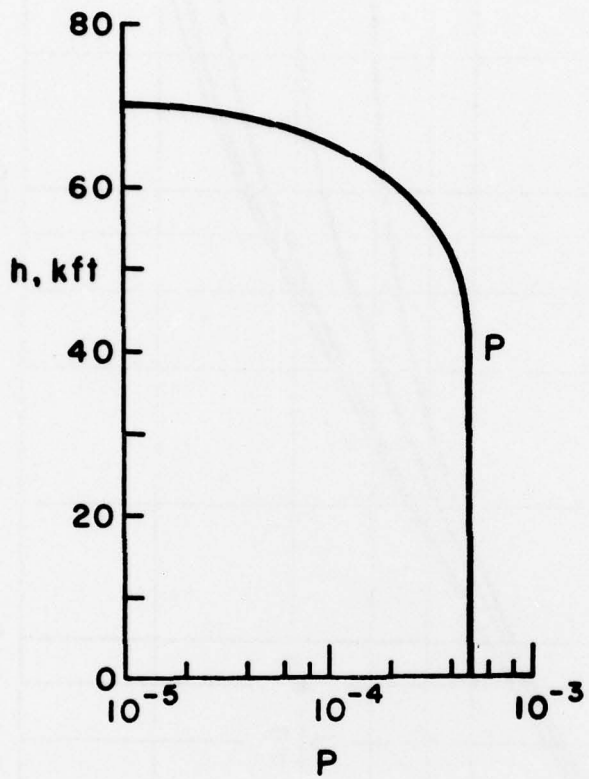

Figure 6. Recommended  $P$  values from reference 9 for severe turbulence (storms or strong convection)

In addition to wing loads it is also desirable to determine design values of the gust loads on the horizontal and vertical tail surfaces. In Ref. 7 it was found that a zero degree of freedom (ODF) model produced consistent and useful estimates of gust loads in the vertical tail. Estimation of gust loads on the horizontal tail requires the use of the more complex two-degree-of-freedom modeling since it is significantly influenced by the downwash from the wing. Alternatively, use the discrete gust design procedure.

The ODF model is a subcase of the 1DF model already discussed. It is equivalent to the 1DF model with infinite aircraft weight. In this case, however, the designer is interested in vertical tail load expressed in units of force (lbs) instead of units of acceleration. In this case the r.m.s. value of vertical tail load,  $\sigma_{P_{VT}}$ , is given by the relations

$$A_{VT} = \frac{a\rho SU}{2} K_{\phi} \quad (16)$$

$$\sigma_{P_{VT}} = A_{VT}\sigma_w \quad (17)$$

where

$a$  = vertical tail lift curve slope

$S$  = vertical tail area

$K_{\phi}$  is obtained from Fig. 4 using  $\mu = \infty$  and the mean aerodynamic chord of the vertical tail to calculate  $2L/c_{VT} = 1500/c_{VT}$ .

The evaluation of  $N_{O_{VT}}$  proceeds by determining  $k_o$  at  $\mu = \infty$  and  $2L/c = 1500/c_{VT}$  from Fig. 5 and substituting into the relation

$$N_{O_{VT}} = \frac{U}{\pi c_{VT}} k_o \quad (18)$$

As shown in Eq. (15), the estimation of  $A$  and  $N_o$  for a particular aircraft and flight conditions completely specifies the rate at which any given load level is likely to be exceeded

However, if the design criterion specifies the rate of exceedance,  $N$ , and the corresponding gust design load factor is to be determined, a more useful form of this relation is

$$\Delta n_d = A_{\Delta n} \sigma_w \ln \left( \frac{N}{PN_o} \right)^{-1} \quad (16)$$

The equivalent form of this equation for use in specifying a vertical tail design load is

$$P_{VT_d} = A_{VT} \sigma_w \ln \left( \frac{N}{PN_{oVT}} \right)^{-1} \quad (17)$$

It is also possible to obtain design loads for the wing and tail in a simpler fashion analogous to the discrete gust design method.

$$\Delta n_d = A_{\Delta n} \frac{K_\phi}{K_g} U_D$$

Where  $U_D$  = gust design velocity (usually 50 fps.) this method does not require an evaluation of  $N_o$ ,  $\sigma_w$ , or  $P$ , but it also does not yield any frequency of exceedance estimates.

The next section illustrates the computation of the load exceedance functions with a flow chart and sample case.

### 3. FLOW CHART AND SAMPLE CALCULATION

The calculation of the gust load exceedance parameters and their use in determining the design just load are illustrated by a flow chart and a numerical example in this section.

FLOWCHART FOR ESTIMATION OF LOADS ON WING AND VERTICAL  
TAIL DUE TO ATMOSPHERIC TURBULENCE USING A SIMPLIFIED  
POWER SPECTRAL TECHNIQUE

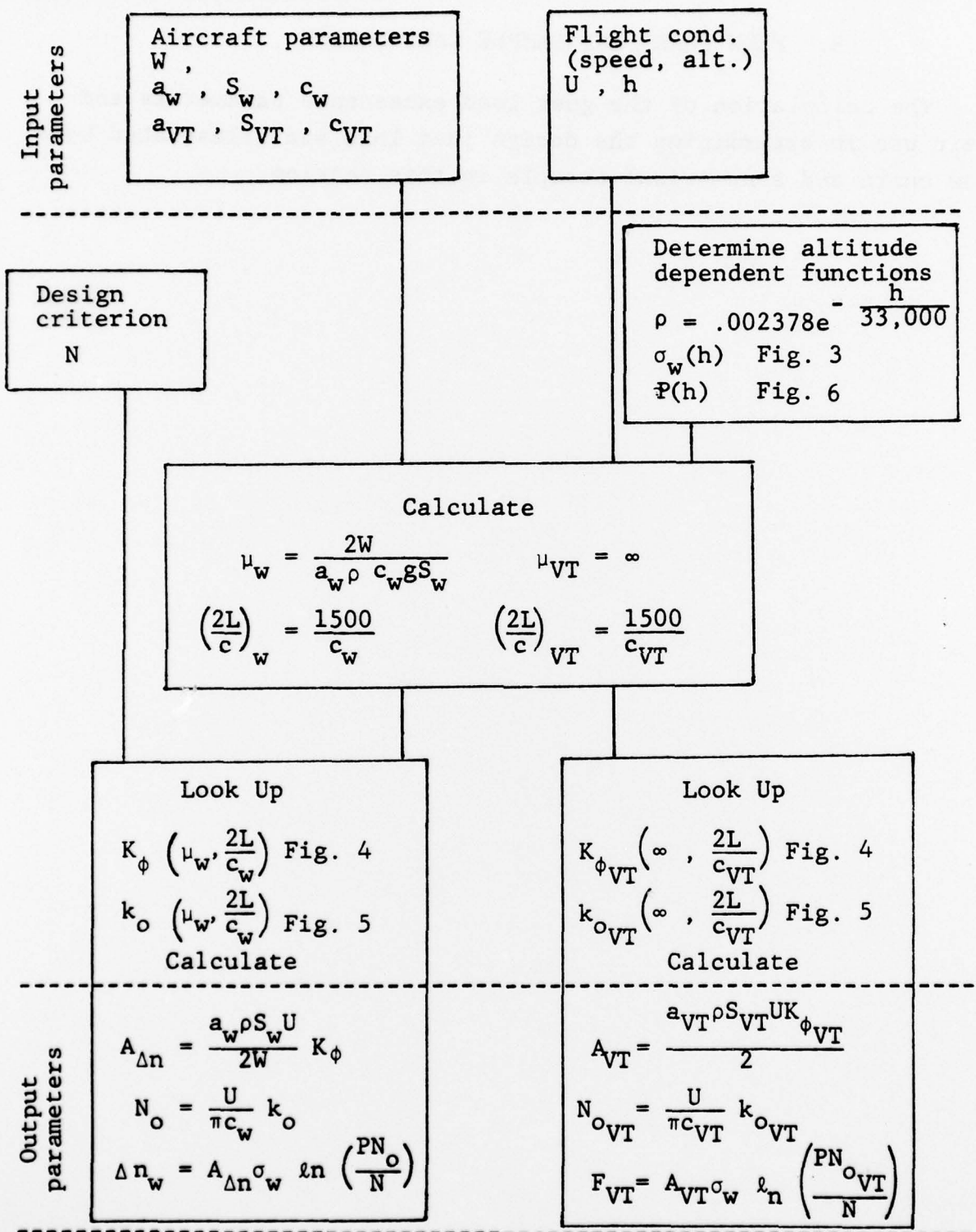

### Sample Calculation

Problem: Estimate the loads on the wing and vertical tail due to turbulence which will not be exceeded more than 10 times in 30,000 hours of flight.

Necessary aircraft parameters are:

$$W = 2950 \text{ lb}$$

$$a_w = 4.88 \text{ per radian}$$

$$S_w = 174. \text{ ft}^2$$

$$c_w = 4.57 \text{ ft}$$

$$a_{VT} = \pi \text{ per radian}$$

$$S_{VT} = 18.57 \text{ ft}^2$$

$$c_{VT} = 3.75 \text{ ft}$$

Flight conditions:

$$h = 5000 \text{ ft}$$

$$U = 219 \text{ fps}$$

The density of air at 5000 ft for standard temperature and pressure is

$$\rho = .00205 \text{ slug/ft}^3$$

$$\sigma_w \text{ from Fig. 3 is } 6.6 \text{ fps}$$

$$P \text{ from Fig. 6 is } 5 \times 10^{-4}$$

For a rate of load exceedance less than 10(5 positive, 5 negative) in 30,000 hours,  $N$  the rate of positive crossings must be

$$N = \frac{5}{(30,000)(3,600)} = 4.63 \times 10^{-8}$$

$$\mu_w = \frac{2W}{a_w c_w g S_w} = \frac{2(2950)}{4.88(.00205)(4.57)(32.2)(174.)} = 23.03$$

$$\frac{2L}{c_w} = \frac{1500}{4.57} = 328.$$

$$\mu_{VT} = \infty$$

$$\frac{2L}{c_{VT}} = \frac{1500}{3.75} = 400.$$

### Gust Design Wing Load Factor

$$K_\phi (23,328) = .43$$

$$k_o (23,328) = .066$$

$$A_{\Delta n} = \frac{4.88(.00205)(174.)(219.)}{2(2950)} .43 = .0278$$

$$N_o = \frac{219}{\pi(4.57)} .066 = 1.007$$

$$\Delta n_w = (.0278)(6.6) \ln \left[ \frac{5(10^{-4})1.007}{4.62(10^{-8})} \right]$$

$$\Delta n_w = 1.7 \text{ g's}$$

### Gust Design Vertical Tail Load

$$K_{\phi_{VT}} (\infty, 400) \sim .93$$

by extrapolation

$$k_{o_{VT}} (\infty, 469) \sim .017$$

$$A_{VT} = \frac{\pi(.00205)18.57(219.) .93}{2} = 12.2$$

$$N_o = \frac{219}{\pi(3.75)} (.017) = 0.316$$

$$F_{VT} = 12.2(6.6) \ln \left[ \frac{5(10^{-4})(.316)}{4.62(10^{-8})} \right]$$

$$F_{VT} = 655 \text{ lbs}$$

## DESIGN MANUAL REFERENCES

1. Houbolt, J.C.: "Design Manual for Vertical Gusts Based on Power Spectral Techniques," Technical Report No. AFFDL-TR-70-106, December, 1970.
2. Houbolt, J.C., and Williamson, G.G.: "Spectral Gust Response for an Airplane with Vertical Motion and Pitch," Technical Report No. AFFDL-TR-75-121, October, 1975.
3. Houbolt, J.C., and Williamson, G.G.: "A Direct Time History Study of the Response of an Airpoane to Nonstationary Turbulence," Technical Report No. AFFDL-TR-74-148, January, 1975.
4. Peele, E.L.: "A Method for Estimating some Longitudinal and Lateral Rigid-Body Responses of Airplanes to Continuous Atmospheric Turbulence," NASA Report No. NASA-TN-D-6273, August, 1971.
5. Petrakis, J., and Miller, N.: "Responses of Small Rigid Aircraft to Discrete and Continuous Gust Analysis - Phase 1," FAA Report No. FAA-RD-74-160, December, 1975.
6. Williamson, G.G., and Houbolt, J.C.: "Evaluation of Gust Response Parameters for Two-Degree-of-Freedom for Seven General Aviation Aircraft," A.R.A.P. Report No. 282, June, 1976.
7. Williamson, G.G.: "Gust Response Analyses for Ten FAR 23 Airplanes Using a Two-Degree-of-Freedom Power Spectral Technique," A.R.A.P. Report No. 344, July, 1978.
8. Yates, J.E., and Houbolt, J.C.: "On the Aerodynamic Forces of Oscillating Two-dimensional Lifting Surfaces," A.R.A.P. Report No. 156, May 1971.
9. Houbolt, J.C.: "Updated Gust Design Values for use with AFFDL-70-106," A.R.A.P. Report No. 204, November 1973.