

AD-A064 326

AIRESEARCH MFG CO OF ARIZONA PHOENIX
RESEARCH AND EVALUATION PROGRAM ON A BACKUP CONTROL SYSTEM FOR --ETC(U)
SEP 78 T G SUTTON

F/G 21/5

DAA639-77-C-0186

UNCLASSIFIED

41-2111

HDL-CR-78-186-1

NL

1 OF 1
AD
A064326



END
DATE
FILMED
4 --79
DDC

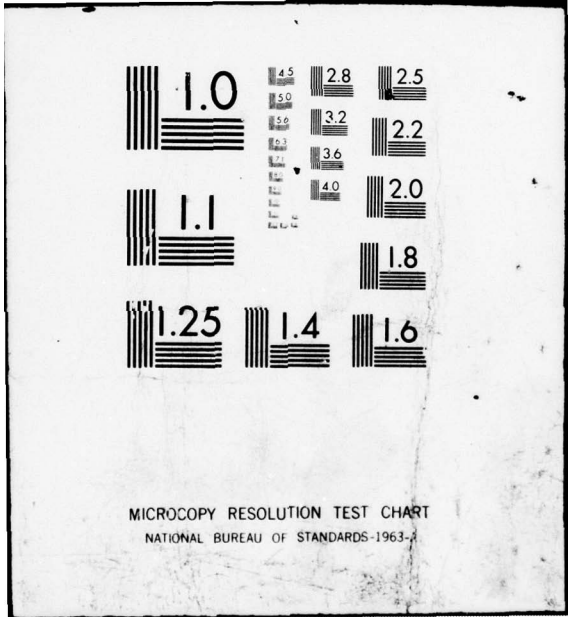

ADA 064326

DDC FILE COPY

HDL-CR-78-186-1

LEVEL



SEPTEMBER 1978

Final Report: Research and Evaluation Program on a Backup Control System for Gas Turbine Engines

By
Trevor G. Sutton

Prepared by
AiResearch Manufacturing Company of Arizona
111 South 34th Street
Phoenix, Arizona 85034

Under contract
DAAG39-77-C-0186

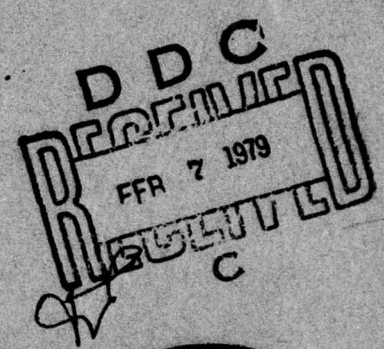

**U.S. Army Electronics Research
and Development Command
Harry Diamond Laboratories
Adelphi, MD 20783**

Approved for public release; distribution unlimited.

79 12 05 002

The findings in this report are not to be construed as an official Department of the Army position unless so designated by other authorized documents.

Citation of manufacturers' or trade names does not constitute an official endorsement or approval of the use thereof.

Destroy this report when it is no longer needed. Do not return it to the originator.

Unclassified

SECURITY CLASSIFICATION OF THIS PAGE (When Data Entered)

19 REPORT DOCUMENTATION PAGE		READ INSTRUCTIONS BEFORE COMPLETING FORM
18 1. REPORT NUMBER HDL-CR-78-186-1	2. GOVT ACCESSION NO.	3. RECIPIENT'S CATALOG NUMBER
6 4. TITLE (and Subtitle) Final Report Research and Evaluation Program on a Backup Control System for Gas Turbine Engines,	9	5. TYPE OF REPORT & PERIOD COVERED Final Report, for Period of Oct 77 1977 Aug 78
		6. PERFORMING ORG. REPORT NUMBER 41-2111
10 7. AUTHOR(s) Trevor G. Sutton	14	8. CONTRACT OR GRANT NUMBER(s) DAAG39-77-C-0186
9. PERFORMING ORGANIZATION NAME AND ADDRESS AiResearch Manufacturing Company of Arizona 111 South 34th Street Phoenix, Arizona 85034	11	10. PROGRAM ELEMENT, PROJECT, TASK AREA & WORK UNIT NUMBERS Program Element: 6.21.14.A
11. CONTROLLING OFFICE NAME AND ADDRESS Harry Diamond Laboratories 2800 Powder Mill Road Adelphi, MD 20783		12. REPORT DATE Sep 1977 1978
14. MONITORING AGENCY NAME & ADDRESS (if different from Controlling Office) 1238p.	15	13. NUMBER OF PAGES 37
		15. SECURITY CLASS. (of this report) Unclassified
15a. DECLASSIFICATION/DOWNGRADING SCHEDULE		
16. DISTRIBUTION STATEMENT (of this Report) Approved for public release; distribution unlimited.		
17. DISTRIBUTION STATEMENT (of the abstract entered in Block 20, if different from Report)		
18. SUPPLEMENTARY NOTES HDL Project 304734 AMCMS Code: 612114.11.H3700		
19. KEY WORDS (Continue on reverse side if necessary and identify by block number) Final Report Control System Fluidic Gas Turbine Engines		
20. ABSTRACT (Continue on reverse side if necessary and identify by block number) This report presents the results of a program conducted by AiResearch and funded by Harry Diamond Laboratories to investigate backup control systems for gas turbine engines which could be used in military ground vehicles. The program addressed the control system requirements that are deemed necessary to provide		

79 00 1

↓
a military gas turbine powered vehicle with battlefield survivability and minimal restriction on the capability of completing the vehicle mission.

This study showed that a parallel dissimilar technology backup control was the desirable approach and that fluidics was the ideal technology to perform this function due to its low cost, reliability, immunity to radiation, and ability to perform computation and logic commensurate with the requirements of achieving mission completion with no degradation in the vehicle's battlefield survivability. ←

ACCESSION for

NTIS Write Section
DDC R & H Section
UNAVIS/NOTED
JUSTIFIED

BY DISTRIBUTION AVAILABILITY CODES
D. SPECIAL

HA

FOREWORD

This is the final report of a program conducted by AiResearch Manufacturing Company of Arizona, a Division of The Garrett Corporation, for the Department of the Army, Harry Diamond Laboratories, to study the requirements for backup control on typical military automotive gas turbine engines. The Industrial Turbines International GT601 is such an engine and this was used for detailed study of the control requirements.

The program was authorized by the Department of the Army under Contract DAAG39-77-C-0186 and was conducted from October 1977 through August 1978 under AiResearch Master Work Order 3409-248131-01. John Goto of the Harry Diamond Laboratories administered the program for the Army.

Publication of this report does not constitute U.S. Army approval of the findings or conclusions presented herein. It is published only by the exchange of information as required under Contract Sequence AA002.

CONTENTS

	<u>Page</u>
FOREWORD	3
1. INTRODUCTION	7
1.1 Background	7
1.2 Statement of Work	8
1.3 Program Schedule	9
2. INVESTIGATION	9
2.1 Description of Gas Turbine Controls	9
2.2 Control System Requirements	14
2.3 Control System Implementation	17
2.4 Failure Detection	21
2.5 Interface of Primary and Backup Control	25
2.6 Development Areas for System	28
3. CONCLUSIONS AND RECOMMENDATIONS	30
DISTRIBUTION	32

ILLUSTRATIONS

<u>Figure</u>		<u>Page</u>
1	Schedule for research and development program of backup control system for gas turbine engines	9
2	Schematic diagram of typical military automotive gas turbine engine	10
3	Block diagrams of typical automotive gas turbine control systems	12
4	Block diagram of existing fuel control system for GT601 engine	13
5	Example of full authority electronic control system	13
6	Block diagram of fuel control system with modified electronic/hydraulic channel, fluidic backup channel, and common scheduling valve	16
7	Block diagram of fuel control system with existing electronic/hydraulic channel and fluidic backup channel	16
8	Control system using simplified electronics and metering system	17
9	T ₄ sensor for GT601 engine	19
10	Compressor discharge pressure versus gas generator rotational speed, N _{GG}	20
11	Schematic diagram of fuel control	22
12	Inlet guide vane control for power turbine	23
13	Block diagram of starting inhibit logic	23
14	Schematic diagram of failure detection circuit	25
15	Fluidic interface	26
16	Schematic diagram of interface	27
17	Major blocks of control system	30
<u>Table</u>		<u>Page</u>
1	Sensed Parameters	19

1. INTRODUCTION

This report presents the results of a program conducted by AiResearch Manufacturing Company of Arizona, a Division of The Garrett Corporation, to study the requirements for backup control systems on gas turbine engines used in military vehicles. Concepts of using fluidics as the backup control technology were evaluated for the Industrial Turbines International GT601 engine as an example of this type of engine. The prime requirements for all control systems studied for the military environment were high reliability, low cost, and battlefield survivability.

1.1 Background

The gas turbine engine has, for the past 40 years, been developed as a prime mover for many applications. It is only recently that this type of power plant has been actively pursued as a practical system for automotive applications. Several gas turbines are under development or in use, ranging from the 120- to 1500-hp output, designed for cars, trucks, and tracked vehicles. All these engines are fairly complex in that they utilize variable geometry and some form of heat exchanger (recuperator {stationary}, regenerator {rotary}) to improve engine efficiency. The complexity has led to the use of electronics to achieve control logic at a reasonable cost, to provide the ability to alter requirements during development, to provide growth or adaptability of the control system to utilize alternate transmissions, and to meet many difficult installation requirements. Two types of electronic systems are used: full authority and limited authority trim control. Catastrophic failure modes of electronic controls necessitate redundant control systems. Fluidics has been identified as a suitable technology for these backup controls because of its high reliability, computational capability at acceptable cost, and resistance to the environment of the military vehicle.

For 14 years AiResearch has conducted research in fluidics and has been able to apply the technology to products used in aircraft and automotive gas turbines. This broad technology base has led to many developments in the applications area of fluidics, thus improving the capability of AiResearch to design products to operate in the extreme conditions of the gas turbine environment with high reliability.

Typical of fluidic applications are the thrust reverser systems for the General Electric CF-6 engine on the McDonnell Douglas DC-10 airplane and the secondary nozzle control of the Concorde supersonic transport. These applications alone have demonstrated the survivability of fluidic controls in high temperature, vibration, and contamination environments. Development programs for gas turbine fuel and control systems, such

as the fuel and load management system for the AiResearch Series 85 gas turbine, have proven that direct application of fluidics to gas turbine control is a viable control technique. Also, integration of sensors, such as those used for turbine inlet temperature measurement of the GT601 engine, has shown the capability of the technology to work beneficially with electronics to achieve the optimum type of control system with respect to survivability, reliability, and cost.

1.2 Statement of Work

The scope of work associated with the study of backup controls for the military gas turbine engine was specified as follows.

Task 1

The concepts of backup control used in aerospace applications of gas turbines and redundant control for aircraft flight control systems will be evaluated with the objective of providing such controls for a gas-turbine-powered military vehicle. The system will be provided with sufficient control so that mobility will not be significantly affected in the event of electronics failure. The resulting system trade-off study will be reviewed with appropriate Army program agencies and, with joint Army/AiResearch concurrence, a control system will be selected and the system requirements specified, based on the Industrial Turbines International (ITI) GT601 engine as a typical military vehicle gas turbine. The study will include backup controls for both the fuel control and the variable geometry control. Fluidic power supply requirements for starting and running will be specified. Block diagrams for the various control systems will be prepared.

Task 2

Detailed control requirements for the fluidic backup controller and sensors will be defined during this task. Methods of assuring correspondence of the signal with the primary channel (to minimize switching transients) will be studied. The control requirements will be specified for both the fuel system and the variable geometry system. Schematics for the system will be prepared.

Task 3

Informal progress reports will be issued bimonthly with a final report issued at completion of Task 2.

1.3 Program Schedule

A bar chart of the program schedule showing the program elements and their periods of completion is presented in Figure 1.

	1977			1978							
	OCT	NOV	DEC	JAN	FEB	MAR	APR	MAY	JUNE	JULY	AUG
TASK 1											
CONCEPT STUDY		██████████									
CONTROL SYSTEM OUTLINE				██████████							
TASK 2											
DETAIL REQUIREMENT STUDY				██████████	██████████	██████████	██████████				
TRANSIENT STUDY								██████████			
FLUIDIC SCHEMATICS									██████████		
TASK 3											
DOCUMENTATION			▲		▲		▲				██████████

Figure 1. Schedule for research and development program of backup control system for gas turbine engines.

2. INVESTIGATION

Investigation of the field of backup controls for a military automotive-type gas turbine required determination of the basic configurations of controls used on existing engines and the limits of their capability under conditions caused by electronics failure, either totally or intermittently. This determination led to the definition of requirements for a backup system, the means of its implementation, failure detection, and a primary and backup control interaction study. Development areas and risk factors were identified.

2.1 Description of Gas Turbine Controls

The gas turbine engines being used by the automotive industry, either in military vehicles or for commercial transportation, are of unique configurations compared with the better known jet engine of the aerospace field. These machines are a cross between the type of engine used for aircraft (known as a turbojet) and the stationary power plant being used in power generation stations.

These engines consist of three major assemblies: the gas generator, the power turbine, and the heat exchanger. Each engine is unique in its specific configuration; however, in all engines, the impact on the control system is such that considerable sequencing and control logic are required. A typical example of this type of engine is shown in Figure 2.

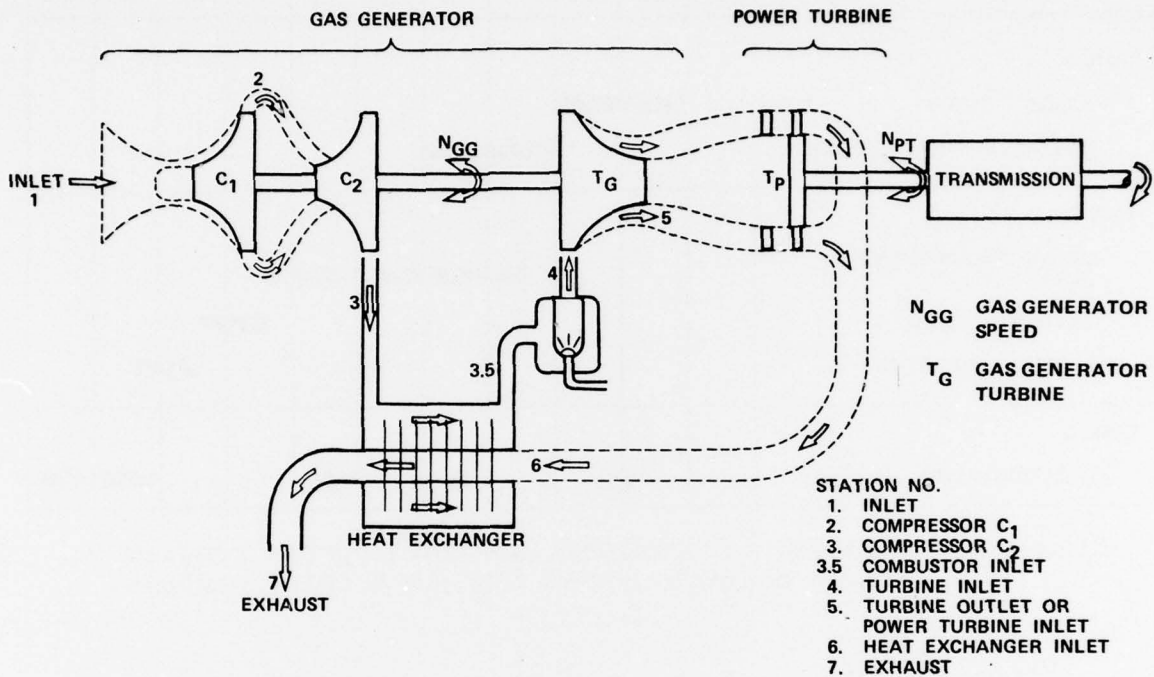

Figure 2. Schematic diagram of typical military automotive gas turbine engine.

There are many variations on this schematic diagram, but the concept is the same. Typically, the gas generator section of the engine is used to provide hot gas for the power turbine. The quantity of this gas is variable depending on the load condition of the power turbine. This means that the gas generator and power turbine speeds must be coupled by the control system to provide the correct gas flow at the required time. To achieve correct flow, not only is the gas generator speed sensed, but vanes are introduced in the flow stream to redirect and vary the flow, thereby effectively changing the flow area of the engine. This change in flow area substantially increases the complexity of the control.

Another item that affects the control system is the need to maintain high engine efficiency at all operating conditions, which means operating with the inlet temperature to the gas generator turbine as high as practical under all load conditions. This control requirement is common to all gas turbines; however, these engines also use a heat exchanger, called a recuperator (if of the stationary plate fin type) or a regenerator (if of the rotating type). These items require special controls to eliminate the potential of high thermal transients which may destroy the heat exchanger or the potential for unburned fuel to be trapped in their cavities which could cause an explosion or high thermal shocks at start-up.

To meet all of these requirements, the control system must be fairly complex. In the past, the highly reliable hydro-mechanical fuel control has met the requirements of gas turbines and is generally accepted as the optimum control system for simple gas turbines. The degree of complexity in the controls of engines required to achieve engine efficiency and safe operation has precluded the use of the hydromechanical control as the primary system. Electronics has become the chosen technology with either full authority over the engine control requirements or a means to trim a much simplified hydromechanical control.

The electronic system has become even more complex due to the need to build failure detection into all the components; although offering the capability of providing the degree of control complexity required, the electronic system is suffering from poor reliability due to problems of maintenance and the inability, at reasonable cost or weight, to eliminate the potential of failure due to electromagnetic, radio frequency, and nuclear radiation. This is a particular problem to the military and may substantially reduce the survivability of vehicles on the battlefield. The gas turbine is not as simple as the piston engine; therefore, operator assistance must be provided to achieve an operable vehicle in primary system failure under battlefield conditions.

One specific automotive engine being considered for the military is the ITI GT601. This engine started out following the aircraft engine control philosophy of providing get home capability in the event of electronic failure and, therefore, takes the approach of a simplified hydromechanical control with electronic trim to provide accuracy and the complex computation required for safe start-up. The system allows the engine to produce in excess of 80-percent power, but it does not allow the engine to be started in electronic control failure. Figure 3 shows these systems.

The block diagrams shown in Figures 4 and 5 show the differences between the authority of the electronic system in controlling the engine as represented by the ITI GT601 engine and controls of other engines.

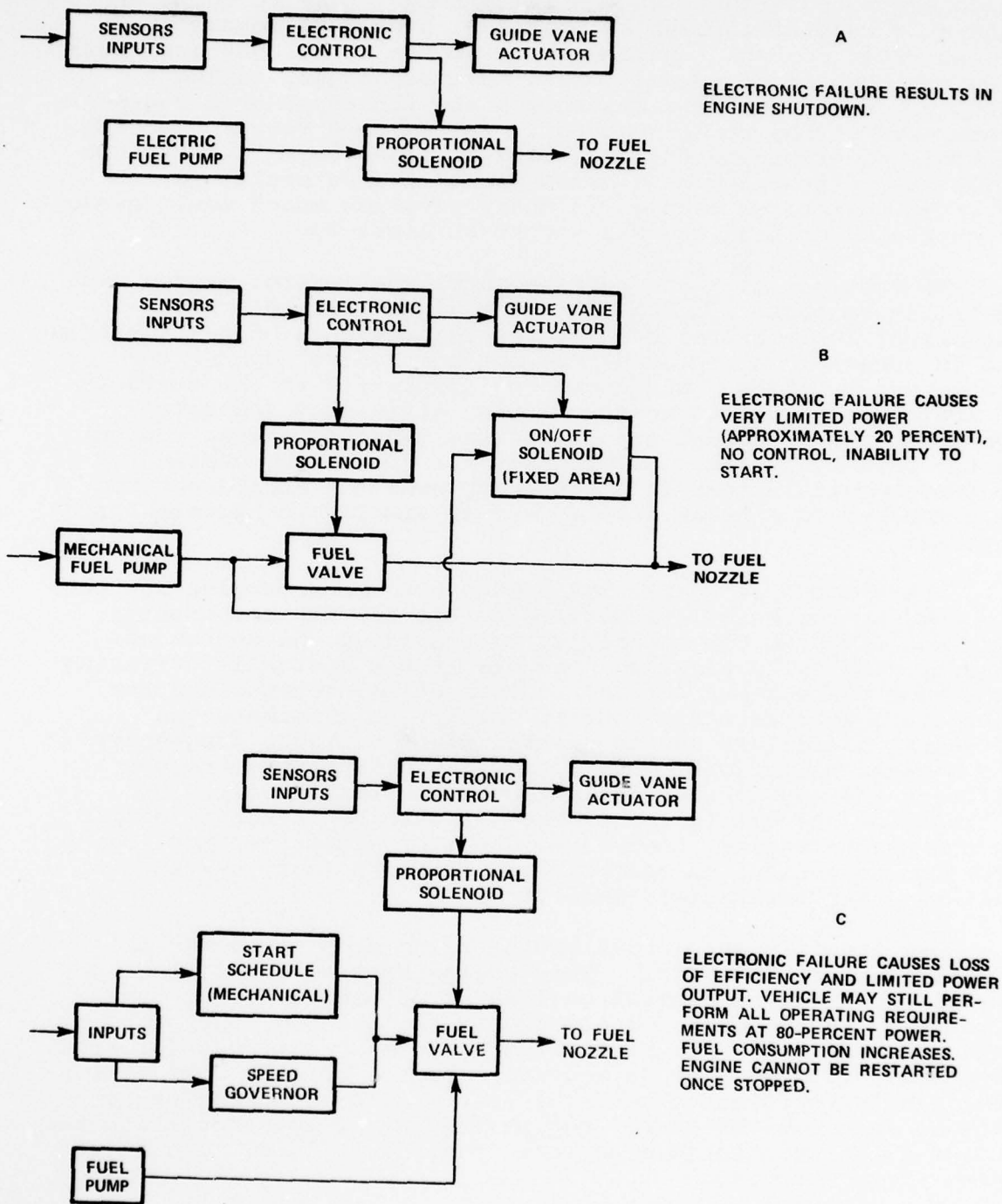

Figure 3. Block diagrams of typical automotive gas turbine control systems.

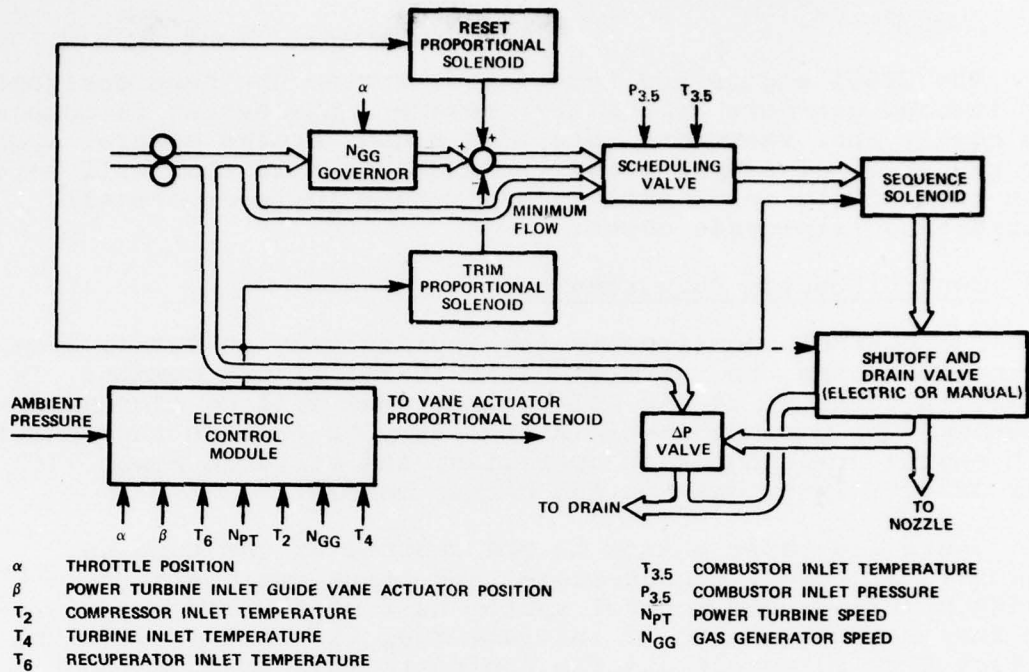

Figure 4. Block diagram of existing fuel control system for GT601 engine.

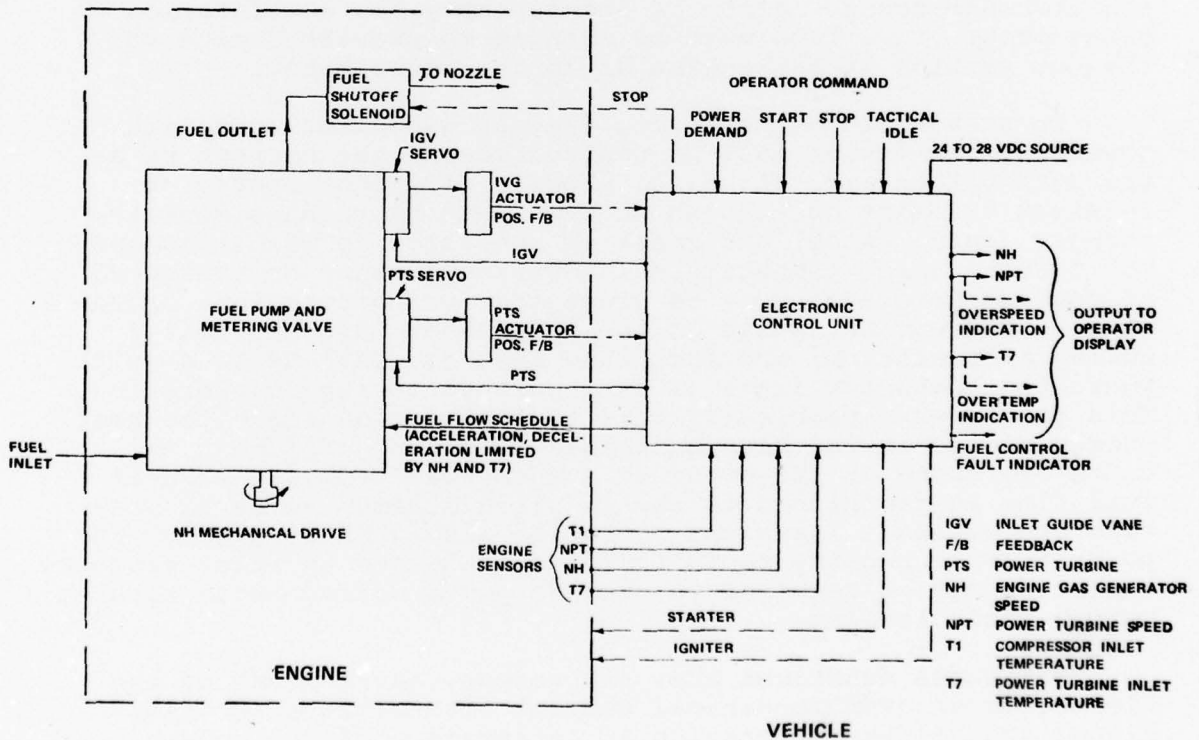

Figure 5. Example of a full authority electronic control system.

The GT601 engine and its control system has been designed for limited get-home capability; however, the system is complex and costly and, therefore, provides a good engine control system for the study of simple primary backup controls that will have true battlefield survivability and result in lower overall initial and life-cycle costs.

2.2 Control System Requirements

The control requirements for engines vary in detail from engine to engine, but several basic functions are common. It is these, in relation to the ITI engine, that will be addressed to determine the minimum controls necessary to provide the vehicle with engine starting, safe operation, and suitable power with a loss of efficiency only in the backup mode.

There are three phases in the control of gas turbine engines: starting, steady-state, and transient operation. During starting, the control system must supply commands to the fuel metering valve to initiate fuel flow and provide the correct flow to accelerate the engine to idle speed without causing overtemperature, compressor surge, or an extended acceleration time. Additionally, logic must be provided to prevent fuel from accumulating in the heat exchanger should ignition not occur. Also, if unacceptably low acceleration rates occur, fuel flow must be stopped to prevent damage to the hot section of the engine or to the recuperator.

In steady-state operation, the gas generator speed and power turbine speeds must be controlled and the correct relationship maintained. Also, to provide efficient operation requires trimming of the engine flow path by turbine geometry changes (guide vanes) and reset of fuel flow to maintain maximum turbine inlet temperatures. Overtemperature or overspeed of the gas generator must be prevented during transient operation of the engine, surge of the compressor must be limited during acceleration, and fuel flow must not fall below a point where the combustor flame is extinguished during deceleration. This is a severe problem on this type of engine since the heat energy stored in the heat exchanger is often sufficient to cause overspeed in the event of sudden load removal, even if fuel flow is diminished to the required minimum value to sustain combustion. Transient operation also greatly affects the power turbine because rapid full range changes in inlet geometry variation may be required to provide power during rapid turbine output shaft loading.

All these functions are, at present, carried out by the electronic or hydromechanical control with electronic trim. Either control has to provide an integration of the sensed

parameters with sufficient accuracy and response rate to provide smooth safe control. In the ITI GT601 engine, the basic requirements of steady-state speed governing for both the gas generator and the power turbine are handled by the hydro-mechanical control. Limited capability transient control also is provided by hydromechanical scheduling of fuel in response to the combustor inlet pressure and temperature. Minimum flow also is scheduled on this section of the control. All other functions are obtained through electronics. The addition of some control functions to the hydromechanical system would, therefore, allow the control to meet the complete military vehicle requirement in electronic failure. The complexity of applying this approach involves computation and trimming functions outside the capability of hydromechanical technology, either at reasonable cost or with acceptable reliability and accuracy. Fluidics provides the means of synthesizing a completely different control system of much greater overall simplicity and reliability.

Backup controls for the GT601 engine have been studied with the assumption that nearly full capability is required in the backup mode. Consideration must be given to a parallel fuel authority dissimilar technology backup control which can provide the functions of the primary system except for those acceptable limitations such as decreased engine fuel efficiency and less smooth operation which relates to decreased control accuracy. Early studies of two possible control modes are shown in Figures 6 and 7. Figure 6 shows an approach that combines a controlled hydromechanical control with electronics and fluidics. Figure 7 shows an approach wherein a totally separate redundant backup channel is employed with the present GT601 control system. Either approach represents a cost increase and due to increased number of components, a potential increase in number of failures, even though the failures do not affect the requirements of vehicle survivability.

A third approach is the use of a simplified fuel metering system. This system would provide the capability of controlling all functions in both the primary electronic system and the fluidic backup system with a means of detecting failure to provide automatic switchover or indication of the need for manual reset of the control. If it is assured that the switchover and backup dissimilar technology control is highly reliable, this approach may offer the least number of components, lowest cost, and most reliable approach in meeting the control requirements. Figure 8 shows this concept.

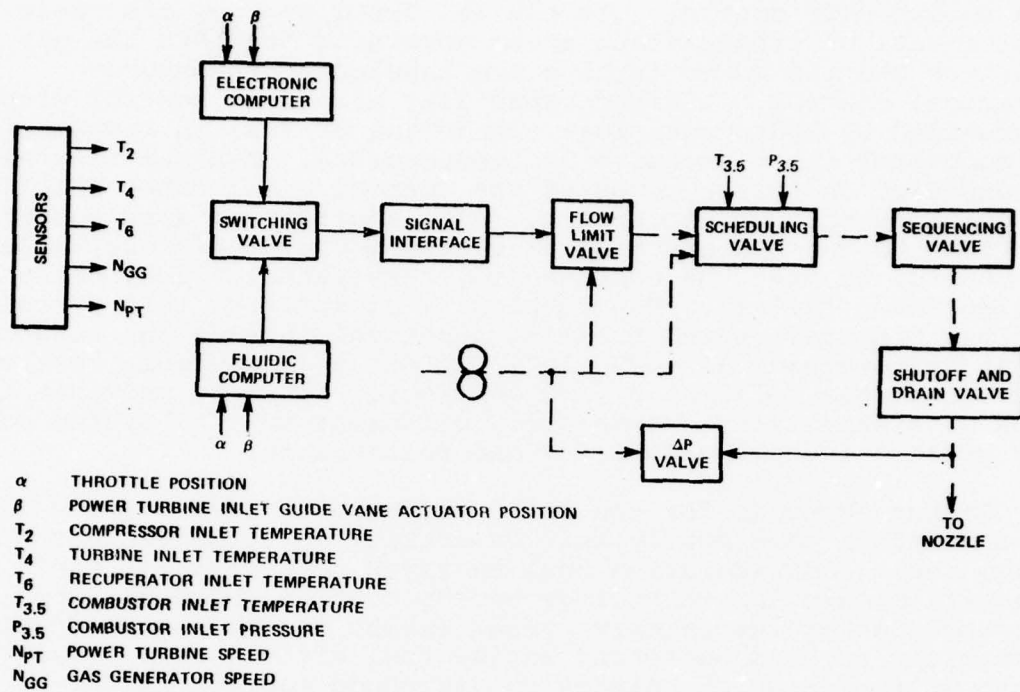

Figure 6. Block diagram of fuel control system with modified electronic/hydraulic channel, fluidic backup channel, and common scheduling valve.

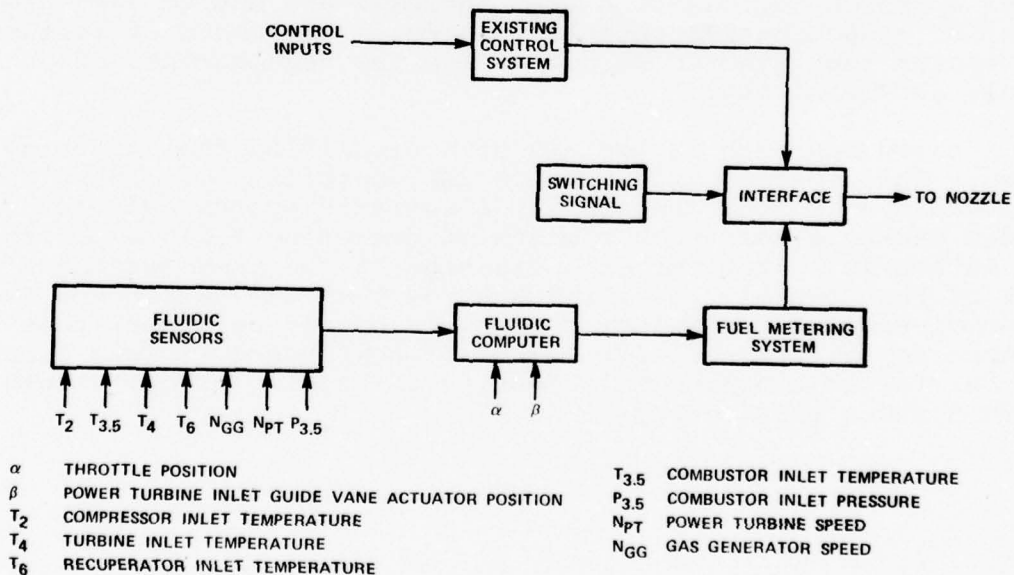

Figure 7. Block diagram of fuel control system with existing electronic/hydraulic channel and fluidic backup channel.

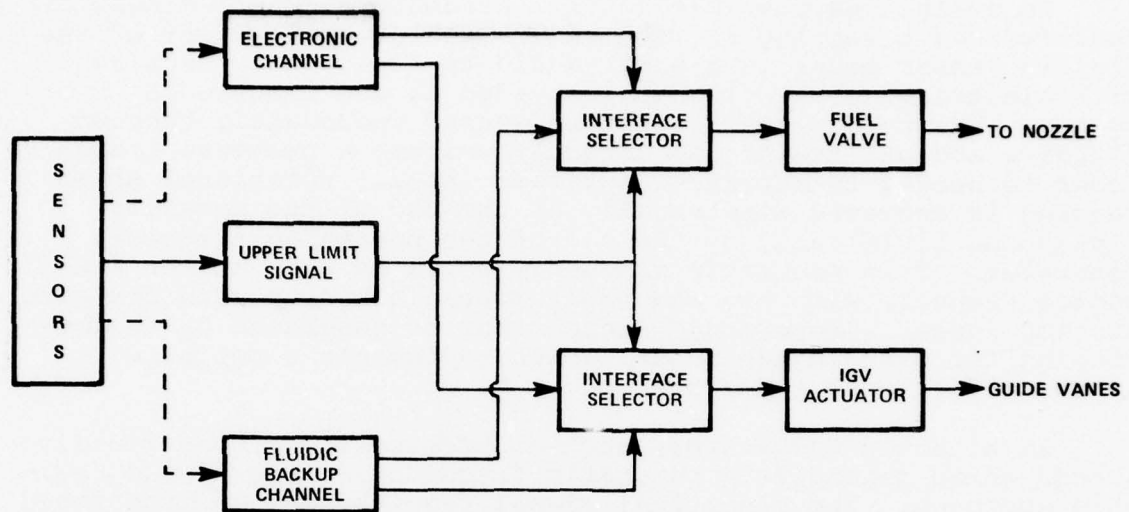

Figure 8. Control system using simplified electronics and metering system.

2.3 Control System Implementation

Implementation of the complete control system in its simplest form would be as shown in Figure 8. This system, with each channel having full authority, would meet system requirements. The controller would, therefore, consist of the basic electronic primary control system and the fluidic backup control, either of which, upon selection by the fault detector or manual input, would directly operate the fuel metering valve to supply fuel to the nozzles.

The control may be divided in the areas of sensing, computation, failure detection, mode selection, and the metering valve.

2.3.1 Sensors - The basic parameters to be sensed in any engine are pressure, temperature, and rotational speed. These may be electrical, fluidic, mechanical, or a combination of these. The reliability of the sensing device needs to be determined. Sensors, which produce electrical outputs, generally do not have high reliability in high temperature operating environments such as gas turbine engines. Pressure sensors or transducers are the least reliable devices, and thermocouples used for temperature measurement do not have high reliability in the hot gas areas of the gas turbine when temperatures exceed 1400F. This is also true of mechanical sensors. Therefore, the need for two means of sensing electrical parameters becomes apparent.

In evaluating possible control parameters, where single or dual-redundant sensing is required, the high reliability of the fluidic sensor makes it a good candidate for primary sensing with electrical pick-off being provided to the electronic system. Pressure signals would be sensed redundantly because fluidics accepts the signal directly whereas a pressure transducer is needed to receive electronic input. Rotational speed sensing is achieved electrically by the use of the monopole pickup and fluidically by the use of the pneumatic frequency generator. This pneumatic frequency would be used as the fluidic control sensor, with the redundant monopole backup used for electronics input. Temperature signals may be generated by thermocouples for electronics input, which represents a reliable approach for lower temperatures.

At higher temperatures, such as turbine inlet, the fluidic sensor which generates a pneumatic frequency offers a good reliable approach. The electrical signal required may be transduced by this type of sensor. Table 1 shows sensor approaches where redundant controls are used. Detailed studies and failure analyses of the system would be needed to decide whether redundant sensors are required. These studies would include cost consideration and problems of installation. Whenever possible, a single sensor, with multiple readouts, may offer a good solution, providing that high reliability is achieved. Particularly, this may be true for temperature and speed measurements. The use of fluidic sensors would provide, in both measurements, a signal with a pneumatic frequency output. This output may be applied directly to the fluidic converter and also converted via rugged reliable electrical devices, such as piezoceramic discs, to an electrical frequency for electronics. An example of a sensor of this type, which provides both pneumatic and electric frequency output, is the existing fluidic turbine inlet temperature sensor for the ITI GT601 engine shown in Figure 9.

2.3.2 Computation - The primary electronic control and the backup control require computation to perform two sets of functions. The first set is to provide fuel-metering-valve and inlet-guide-vane input signals to operate the engine during steady-state and transient-load conditions. Secondly, logic must be provided to enable engine starting and either (a) to prevent operation of the engine when a failed component is indicated or (b) to switch to the backup control mode.

In the electronic control system, an approach may be taken based on digital techniques using microprocessor technology. This will provide a simple, low cost primary system. Redundant computation paths need not be considered and only minimal inherent self-check failure-mode detection need be implemented. The use of sensors providing frequency inputs simplifies the interface problem. The output for this type of circuitry is readily converted to an analog signal for comparison with other analog signals used to indicate failure and is also consistent with the fluidic circuitry design.

TABLE 1
SENSED PARAMETERS

Parameter	Technology		
	Electronic	Fluidic	Mechanical
PRESSURE			
Compressor Inlet P_2 *	Transducer	Direct	Piston, Bellows or Diaphragms
Compressor Inlet $P_{3.5}$ *	Transducer	Direct	
ROTATIONAL SPEED			
Gas Generator Power Turbine	Monopole Pickup or Jet Interrupter with Transducer	Jet Interrupter	Flyweight Governor
TEMPERATURE			
Compressor Inlet*	Thermocouple	Pneumatic Bridge Sensor	Expansion Device
Turbine Inlet	Fluidic Oscillator	Fluidic Oscillator	Fluidic Oscillator
Recuperator Inlet	Thermocouple	Fluidic Oscillator	Expansion Device

*Dual or redundant sensors would be used in the measurement of these parameters.

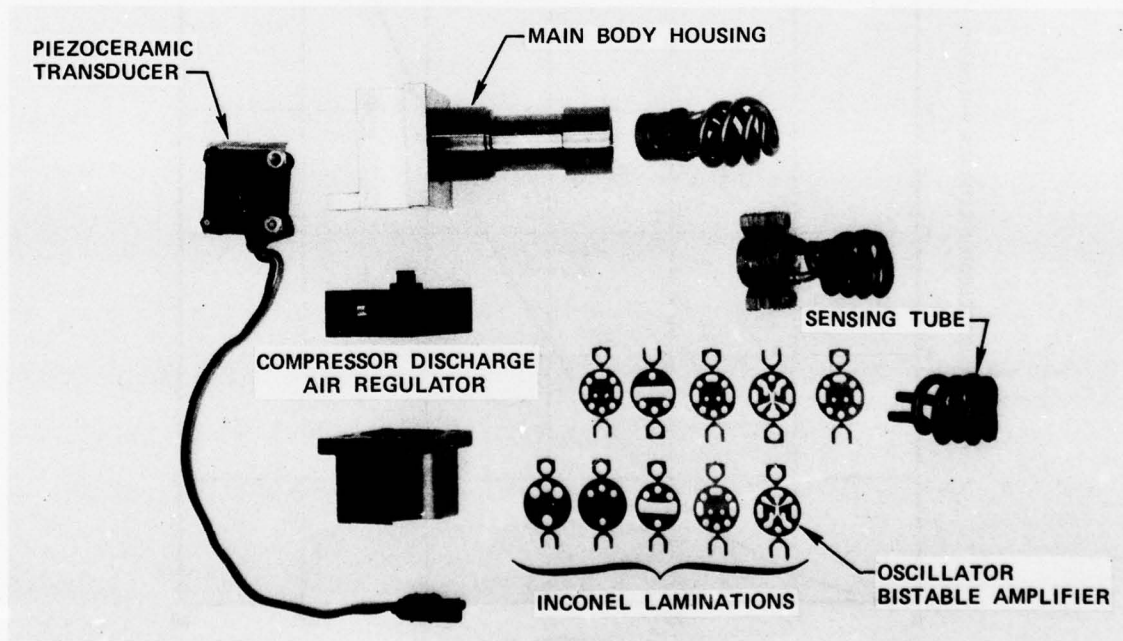

Figure 9. T_4 sensor for GT601 engine.

In the backup mode, computation circuitry required is basically state-of-the-art fluidics. One area that must be addressed when considering any technology for control is the availability of a power source. Electronics requires an electrical power source, mechanical components are directly driven by the engine, and fluidics requires a pneumatic or hydraulic power source. On a gas turbine, pneumatic pressure is available at all times except during starting. During starting, an alternate source of pressure must be provided. On many engines an air pump is available to provide air for the fuel atomizers. If not, another source of pressure must be provided. Figure 10 shows the available pressure for a typical advanced engine of the automotive type as it accelerates to idle at sea level conditions. Computational circuitry is required to operate at gas generator speeds of less than 10 percent, showing that less than 0.5 psig is available from the gas generator compressor.

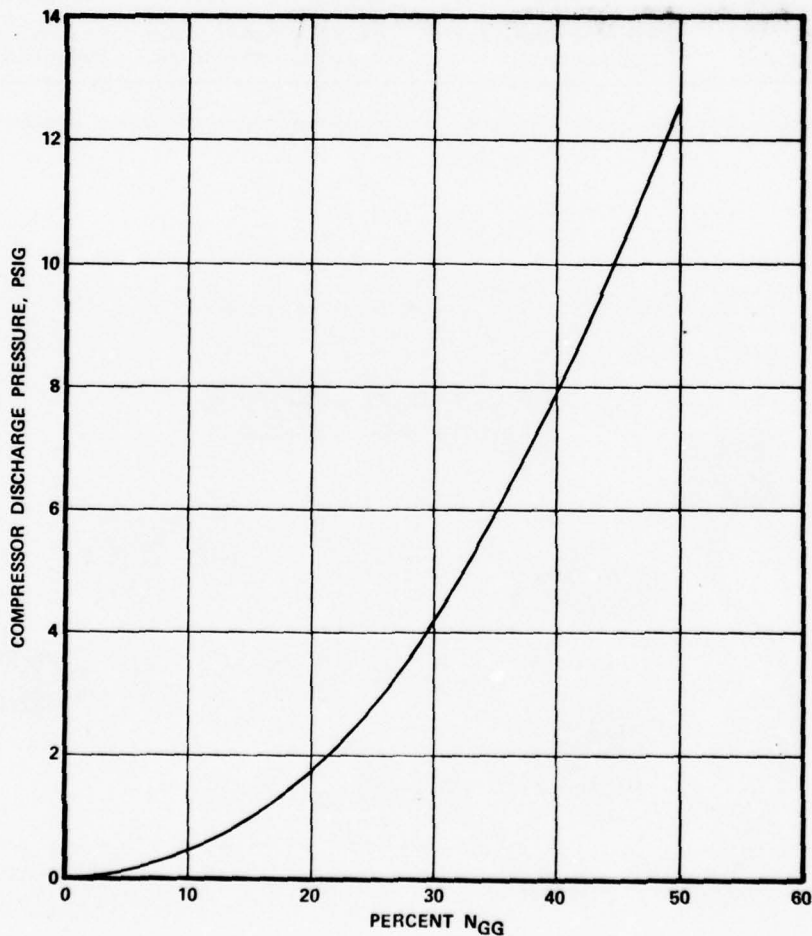

Figure 10. Compressor discharge pressure versus gas generator rotational speed, N_{GG} .

The computational components used in a backup fluidic control are considered as state of the art, and the following system using the GT601 control requirements shows the degree of complexity required for the control system to meet the start and control requirements of the gas turbine engine. Schematics of the fluidic circuits are shown in Figures 11 and 12 for the fuel and IGV controls, respectively. The start-inhibit logic functions required for the backup control are shown in Figure 13. This figure shows the use of two speed signals, a temperature signal, and two timed functions. This logic is required to protect the recuperator or regenerator from excessive temperature transients due to the load of acceleration or failure to light-off. At 8-percent speed, the fuel solenoid is opened by the start circuit, and this signal initiates two timing periods. The 6-s timer requires that a minimum turbine inlet temperature rise rate must be achieved, or the fuel solenoid closes. This detects lightoff. The 25-s timer requires that 95-percent speed be achieved in 25 s or the fuel solenoid shuts down to a hung start (refusal to accelerate) condition.

All other logic associated with starting is simple and uses the speed of the gas generator to establish conditions when action must be taken; i.e., at low speed, the fuel solenoid is opened at a speed below idle, such as 45 percent, where the starter motor is cut out and the igniter is turned off. The foregoing circuits and diagrams identify the basic control system required to provide a parallel backup control to the electronics. The following paragraphs describe the method of integrating the primary and backup systems.

2.4 Failure Detection

Many approaches have been used for failure detection, ranging from providing each control with limited authority such that excessively dangerous or harmful conditions cannot be achieved by either of the controls on its own. This is the approach taken with most aerospace fuel management systems or gas turbine controls to date. In other words, when a control system fails, the backup control has authority to override to the safe limits until the operator has time to manually switch out the bad controller or is able to continue to operate with limited but safe authority. Some electronic systems are designed with built-in automatic failure detection so that they automatically switch off should a failure occur, thereby allowing the backup control full authority.

Until recently, hydromechanical fuel control systems for gas turbines have been relative simple and have not been subject to sudden failure, but rather to a degradation of performance due to wear in their mechanical parts which may be readily diagnosed during maintenance or by the operators not being able to achieve all the operating conditions. With the advent of full authority digital controls to aircraft flight systems,

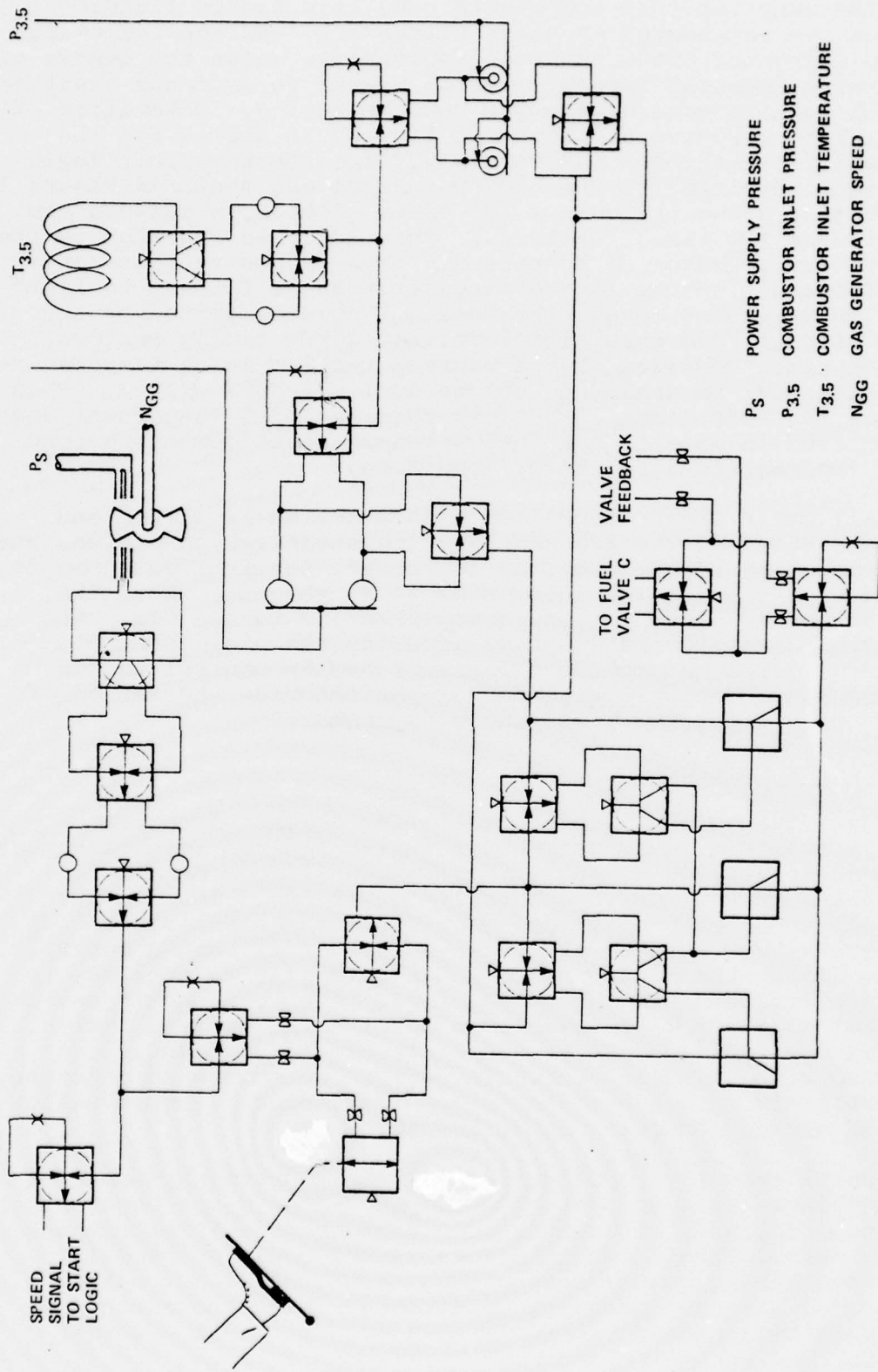

P_S POWER SUPPLY PRESSURE
 P_{3.5} COMBUSTOR INLET PRESSURE
 T_{3.5} COMBUSTOR INLET TEMPERATURE
 NGG GAS GENERATOR SPEED

Figure 11. Schematic diagram of fuel control.

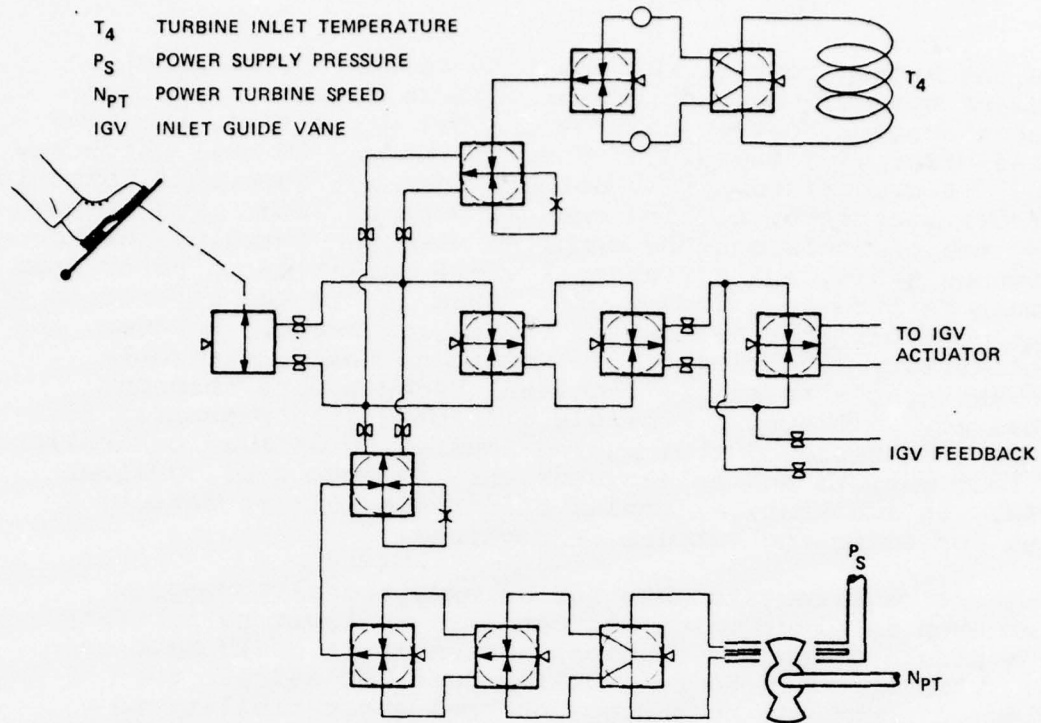

Figure 12. Inlet guide vane control for power turbine.

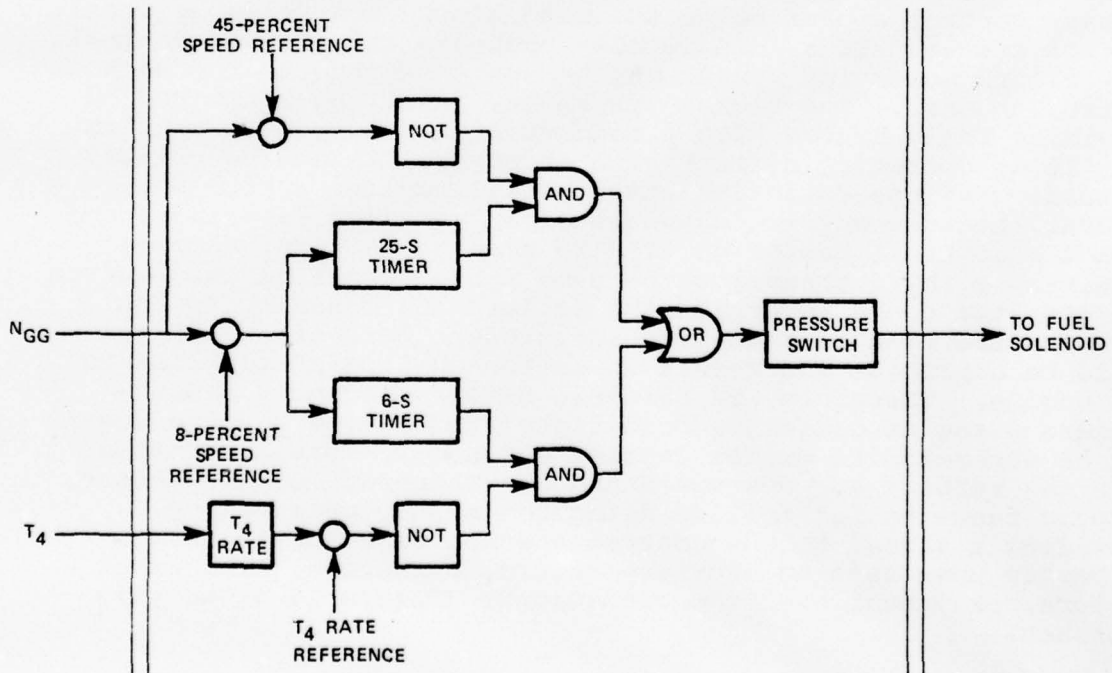

Figure 13. Block diagram of starting inhibit logic.

where the backup control was the same technology parallel redundant system, the problems of failure detection changed. In these systems, either control channel may fail in the same or dissimilar way; therefore, there is no way to tell which has failed. A comparison of two outputs does not determine which is in error; therefore, a third channel must be used. The outputs of any two channels must be compared with the third channel on a continuous basis, and any channel whose outlet is in error from the mean failure is switched off. This led to the generation of flight controls that are called triple redundant. However, due to reliability requirements, it was found that a quadruple redundant system is really required, because more than one channel may fail during a single mission. This potential for failure requires a control system consisting of four controllers with four outputs and an actuator that accepts four parallel inputs. In addition, a complex electronic failure detection system for switching outputs is required.

These requirements make for an exceptionally complex system even in electronics and can lead to lower reliability than a single channel mechanical system if it could have been used. This approach to reliability does not address the problem of identical technology channel susceptibility to externally induced failures (e.g., magnetic radiation effects).

In investigation of controls specifically for gas turbine engines, a highly reliable backup control and a simple electronic primary control appear to be the most simple and reliable total control system. If a failure does occur in the primary control, the failure detection system may be set to switch to the backup control channel. The backup system may itself be monitored by providing the operator with a readout of its output to confirm that it is operating correctly while control is on the primary channel. Failure detection itself still remains a problem, however, because any two channels of information (a primary and a backup control) cannot be used to predict failure, thereby requiring a third channel to be used for determining the failure. The operator could recognize the failure and manually switch; however, the time to recognize and produce corrective action could be a problem and result in excess fuel being supplied to the engine. Therefore, if reliable sensors directly sensing dangerous engine operating conditions are used, a failure signal may be generated to switch control channels. These conditions on a gas turbine are overspeed and overtemperature. Therefore, a logic function for failure detection may be obtained by providing a signal to the control channel selector to switch to backup upon sensing overtemperature, overspeed, electrical failure, or manual override conditions. Figure 14 shows this approach.

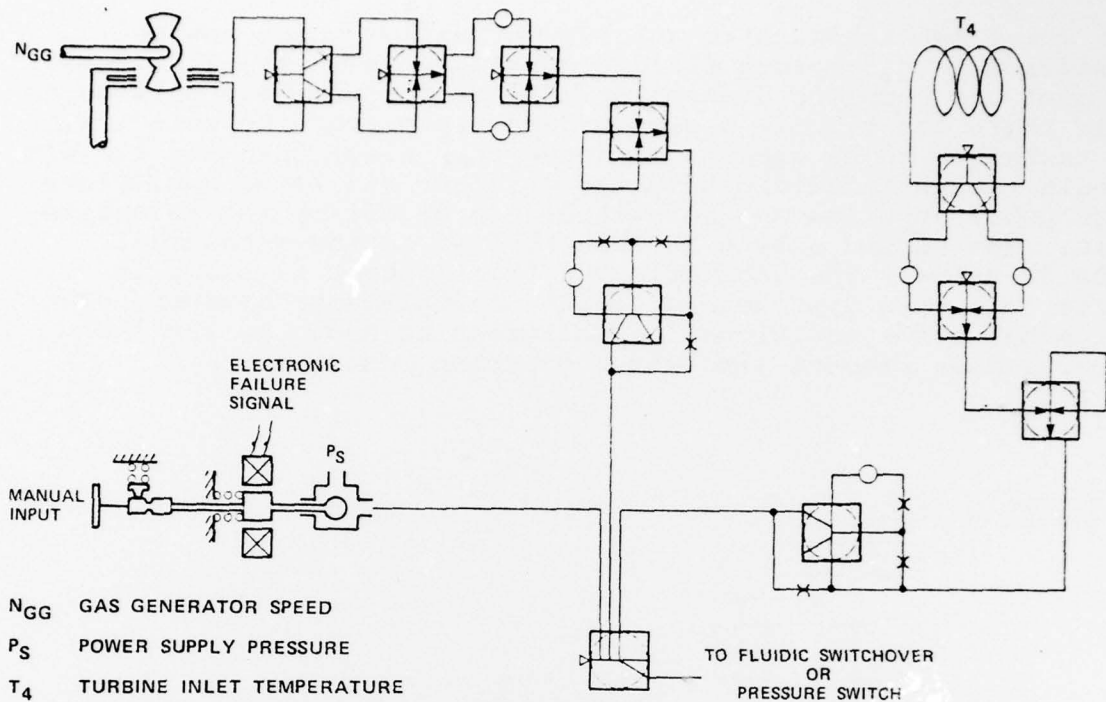

Figure 14. Schematic diagram of failure detection circuit.

2.5 Interface of Primary and Backup Control

The control system, consisting of both the primary full authority electronic control and the backup control, must be operating at the same time and provide similar functions as previously shown. Some form of logic must determine which is in control of the engine at a given time. The two control signals must be supplied to a single final element. This may be a mechanical valve or some device driving a mechanical valve. Many techniques are possible, and a study of the specific system to be controlled must be made to come to the best solution.

The following techniques are applicable to the control system for an engine such as the GT601. In every system, however careful design is required for the switchover transient and channel synchronization. If each channel is not rigged to track exactly, a large transient could occur on switchover, especially if the control loop contains integral control. To minimize the switchover transient problem, it has to be assumed that the only critical transient is that toward an unsafe condition. Therefore, if the failure mode is toward the low speed or idle condition, an acceptable control mode is to switch manually.

The first approach to a failed condition which may be considered is a complete fluidic approach. However, this does not meet the complete dissimilar channel failure mode philosophy since there are fluidic elements downstream from the selector. The technique to be used is bringing both electronic and fluidic signals within a fluidic summary amplifier via fluid amplifiers whose power supplies may be switched on or off by the selection logic. The summed output is then applied to the mechanical actuator valve. The schematic for this concept is shown in Figure 15. This approach is simple to implement; however, other approaches offer additional capabilities as shown by the technique used in present aircraft production controls.

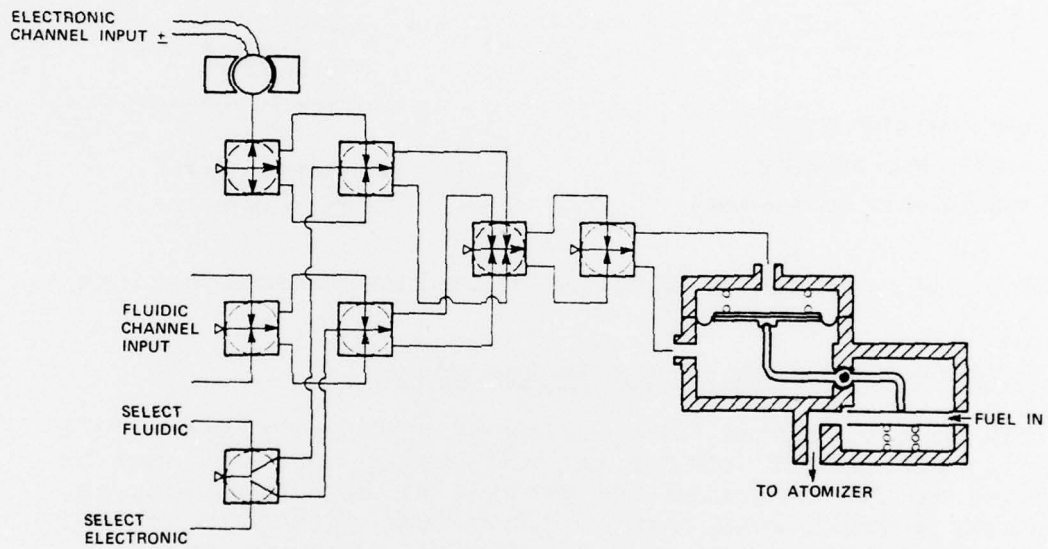

Figure 15. Fluidic interface.

In the approach shown by Figure 16, signal summation is obtained by directly adding the signals which are supplied through two different impedance sources. This approach has only one drawback and that is sizing for response. However, this drawback can be overcome in most applications. The electronic signal may be introduced through a fluidic or pneumatic interface, providing it offers a low impedance source compared with the backup control input. Under normal operation, the electronic signal swamps the backup signal. When a selector switch (or manual) signal is obtained, the poppet valve closes, thereby allowing the effect of the backup control to be seen by the diaphragm. By this approach, no other components are introduced in the backup signal path to the mechanical actuator which meters fuel flow (or provides actuator pressure to the power turbine IGV).

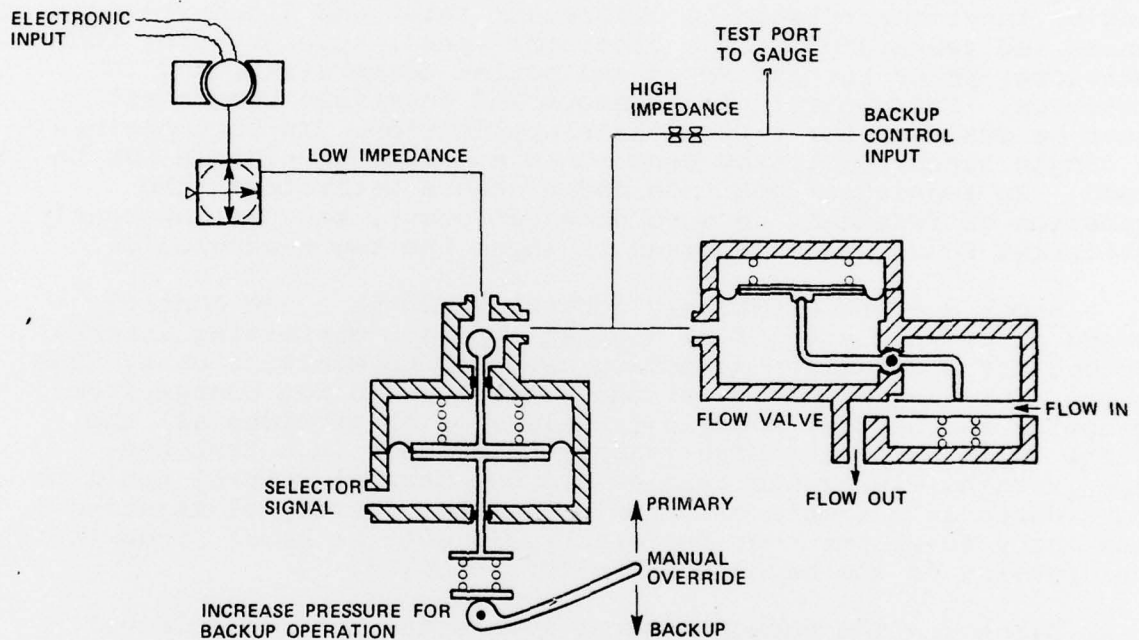

Figure 16. Schematic diagram of interface.

This approach also would aid in minimizing switching transients compared with other approaches since the selector valve may be designed to operate in a "soft" or timed manner, with the capability of instantaneously lowering the control signal toward the under limit condition should a condition be present to cause a rapid fuel increase. Potentially, this approach is the optimum interfacing method for these controls, for both the fuel and the IGV systems. The only differences in

implementation are in sizing and in impedance matching, which are dependent upon flow to meet the response requirements of the mechanical valve used to meter the flow to the engine or the actuator.

2.6 Development Areas for System

The system for the control of this type of engine may be divided into seven major areas as defined by the block diagram of Figure 17. This block diagram indicates the complete control system.

Block 1 - The sensors cover all required sensing devices, as presented in paragraph 2.3.1, including the means of introducing the operator's signals and the feedback signals from the engine functions related to compressor inlet and discharge pressures and temperatures, gas generator speed, turbine inlet temperature, power turbine speed and outlet temperature, and IGV position. These particular sensors and interface components must be designed for a particular application. In some engines a single sensor providing electronic and fluidic signals may be used. In sensing of position and pressure parameters, the question of redundant sensors does not occur, because inherently different sensors are required to input the two technologies.

Block 2 - The electronic control would be a new control based on using a simplified digital approach minimizing internal redundancy and failure detection circuits to minimize cost. The basic start logic portion of the control would not change from existing approaches, wherein the electronics provides all the start logic. For the GT601 engine to be used in a test bed, the existing electronic trimmed hydromechanical control would be considered as a simple electronic channel, thereby eliminating the early development of the electronic control block prior to the proving of the backup controller, Block 3.

Block 3 - The backup control covers the entire fluidic control system including fuel and IGV control, test logic, and failure detection circuit. The system consists of components which are existing; however, the degree of complexity, system integration, and dynamic circuitry to compensate for the control component response represents a major challenge, and a discrete functional block modular approach would be necessary to ensure that functional instructions were correct.

Block 4 - The interface selector circuits and paths for both fuel flow and inlet guide vane signals are shown in Figure 17. The selectors must be designed to accept the signals which are input by the two channels and also the failure detection circuit. Outputs compatible with response rates and the transient switching requirements for the sensor and metering valves must be obtained through these components. This does not represent a high risk area, but development cannot be completed without a full system evaluation of the components.

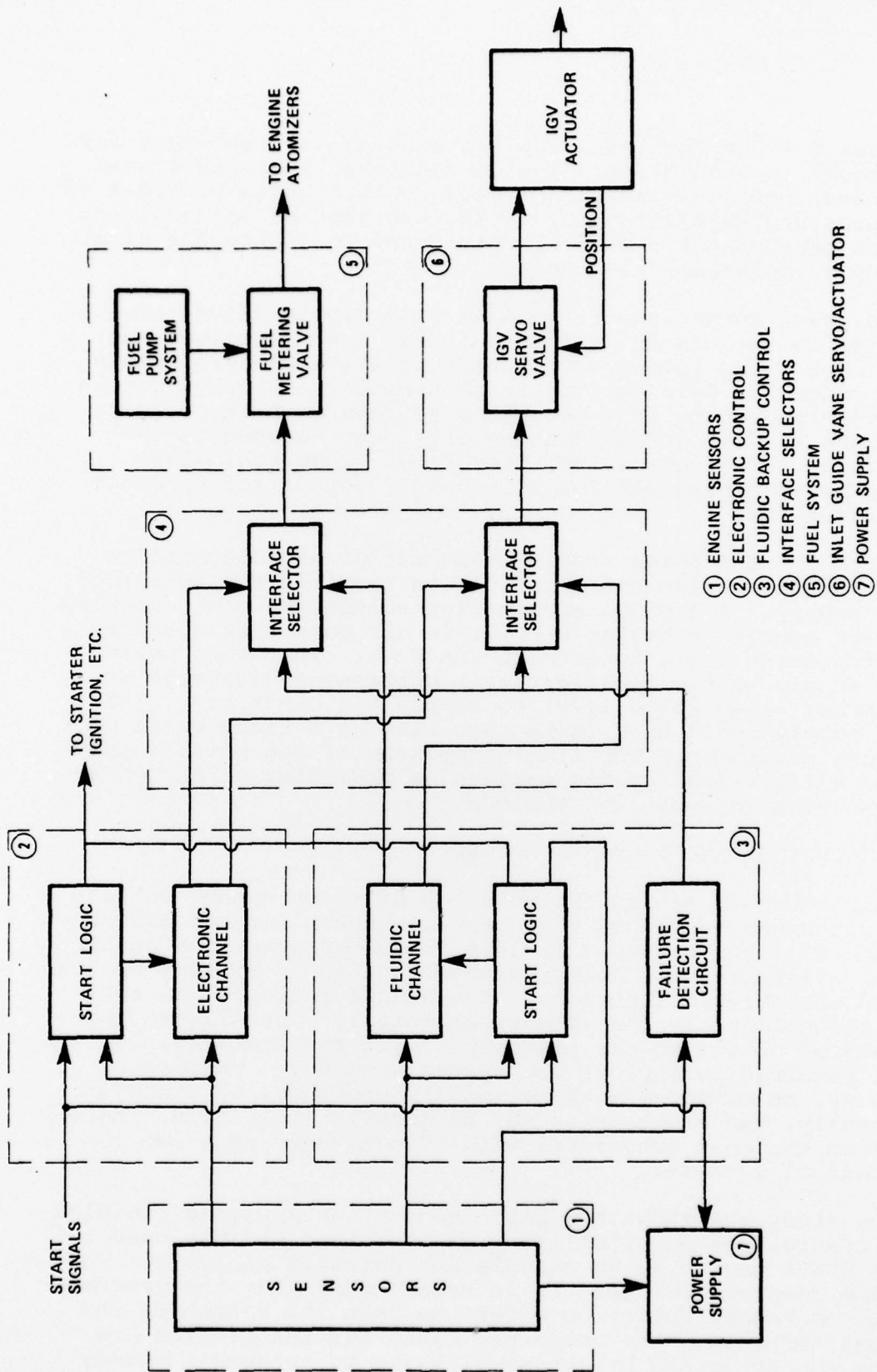

Figure 17. Major blocks of control system.

Block 5 - The fuel metering system does not represent any basic change in technology. The conventional pump and valves may be used; however, instead of flow control being provided by a head pressure regulating valve, the approach of using direct fuel-flow measurement should be considered to enable use of a less complex metering valve design.

The inlet guide vane servovalve is a simple valve; however, its design is influenced by the fact that most actuators must produce high force levels and provide accurate integral positioning control. This fact means that either response must be sacrificed to operate from pneumatic sources or high pressure fluid, such as fuel or lubricating oil, must be used as the motive force. The servovalve, therefore, needs to follow concepts being considered for fluidically controlled aircraft flight actuators.

Block 7 - The power supply is a part of the electronics design, but the application of fluidics requires the design of a power supply. The GT601 application solves the basic problem of a power source by having a built-in air pump that operates during the start cycle to atomize the fuel. This pump would provide supply to the fluidics until compressor discharge pressure reaches an adequate level to supply the circuitry. This fluidic supply would need to be regulated to a fixed value by a pressure regulator. The final component of the power supply would be a filtration system capable of providing maintenance-free operation for extended periods.

3. CONCLUSIONS AND RECOMMENDATIONS

This study of backup controls for military ground vehicle gas turbines has developed a concept of backup control different from most existing controls in that it is designed as a complete parallel dissimilar technology system capable of meeting all the required operational functions. The use of fluidics, as the backup technology for the primary electronic control, provides the means of obtaining the necessary logic for starting, and the control required to improve the system accuracy. Therefore, efficiency, as compared with existing approaches, is improved. Additionally, the electronics may be greatly simplified, thereby minimizing the cost associated with effectively using two complete control systems.

The study has shown the basic concept of applying fluidics to the control system of military gas turbines and has used the ITI GT601 engine as an example for detailed analysis. To prove the complete concept, it is recommended that the program be directed toward follow-on effort to test the system on the GT601 gas turbines. The necessary tasks for the program are shown on the following breakdown of tasks to achieve a timely system development based on highest risk areas being addressed early in the program.

- a. Examine the engine installation problems for sensors and prepare preliminary packaging and installation layout drawings for all engine interface components.
- b. Analyze and design the sensors and computational circuitry required to meet engine performance. Fabricate and develop these components with major emphasis to be placed on control selection logic, sensors, and critical computation elements such as acceleration and deceleration control circuitry.
- c. Design, fabricate, and develop the start and start inhibit logic.
- d. Design and fabricate a complete backup channel using the components from Tasks b and c. At this time, complete simulation of the control transients must be addressed to ensure compatibility with the engine.
- e. Modify the existing control system to conform to the requirements of the primary channel, and install the backup channel for test on the engine in a test cell. Conduct a simulated failure test and a performance test of the engine control system.
- f. Conduct design and cost studies of a simple electronic control channel that will form part of the complete control system.

DISTRIBUTION LIST

Commander IDDR&E
Pentagon, Room 3D 1089
Washington, D.C. 20310
Attn: Ltc. G. Kopesak

Defense Documentation Center
Cameron Station, Building 5
Alexandria, VA 22314
Attn: DDC-TCA (12 copies)

Office of the Deputy Chief of Staff for Research, Development,
and Acquisition
Department of the Army
Washington, D.C. 20310
Attn: DAMA-ARP-P, Dr. V. Garber
Attn: Mr. John Hill, Room 3D424

U.S. Army R&D Group (Europe)
Box 15
F.P.O. New York 09510
Attn: Chief, Aeronautics Branch
Attn: Chief, Engineering Sciences

U.S. Army Research Office
P.O. Box 12211
Research Triangle Park, NC 27709
Attn: James J. Murray, Engineering Sciences Division

BMD Advanced Technology Center
P.O. Box 1500
Huntsville, AL 35807
Attn: J. Papadopoulos

Commander
USA Foreign Science and Technology Center
Federal Office Building
220 7th Street, Northeast
Charlottesville, VA 22901
Attn: DRXST-SD1

Director
Applied Technology Laboratory
Fort Eustis, VA 23604
Attn: George W. Fosdick, DAVDL-EU-SYA

Commander
USA Missile Research and Development Command
Redstone Arsenal, AL 35809
Attn: Redstone Scientific Information Center, DRSMI-RBD
Attn: DRDMI-TGC, William Griffith
Attn: DRDMI-TGC, J. C. Dunaway
Attn: DRCPI-TOE, Fred J. Cheplen

Commander
USA Mobility Equipment Research and Development Center
Fort Belvoir, VA 22060
Attn: Technical Library (Vault)
Attn: DRDME-EM, R. N. Ware (5 copies)

Commander
Edgewood Arsenal
Aberdeen Proving Ground, MD 21010
Attn: SAREA-MT-T, Mr. D. Patton

Commander
U.S. Army ARRADCOM
Dover, NJ 07801
Attn: SARPA-TS-S-#59
Attn: DRDAR-LCN-F, A. E. Schmidlin
Attn: DRDAR-LCW-E, Mr. J. Connor

Commander
Watervliet Arsenal
Watervliet Arsenal, NY 12189
Attn: SARWV-RDT-L

Commander
USA Tank Automotive Research and Development Command
Armor and Company Division, DRDTA-RKT
Building 215
Warren, MI 48090
Attn: T. Kozowyk
Attn: M. Steele

Commander
White Sands Missile Range, NM 88002
Attn: STEWS-AD-L, Technical Library

Commander
U.S. Army Armament Materiel Readiness Command
Rock Island, IL
Attn: DRSAR-RDG-T, Mr. R. Spencer
Attn: DRSAR-ASF

Office of Naval Research
Department of the Navy
Arlington, VA 22217
Attn: Stanley W. Doroff, Code 438
Attn: D. S. Siegel, Code 211

Department of the Navy
Research and Development Plans Division
Room 5D760, Pentagon
Washington, DC 20350
Attn: Benj R. Petrie, Jr.
OP-987P4

Commander
Naval Air Development Center
Warminster, PA 18974
Attn: R. McGiboney, 30424
Attn: Code 8134, Lois Guise

Naval Air Systems Command
Department of the Navy
Washington, D.C. 20360
Attn: Code AIR-52022A, J. Burns
Attn: Code AIR-52022E, D. Houck

Commander
Naval Ship Engineering Center
Philadelphia Division
Philadelphia, PA 19112
Attn: Code 6772, D. Keyser

Commander
Naval Surface Weapons Center
White Oak, MD 20910
Attn: Code 413, Clayton McKindra
Attn: Code WA-33, J. O'Steen

Commander
Naval Ordnance Station
Indianhead, MD 20640
Attn: Code 5123B, J. Morris

Naval Ship Research and Development Center
Bethesda, MD 20084
Attn: Code 1619, Mr. K. Reader

Naval Sea Systems Command
SEA0331H
Washington, D.C. 20362
Attn: A. Chaikin

Commander
Naval Weapons Center
China Lake, CA 93555
Attn: Code 533, Library Division
Attn: Code 5536, Mr. M. D. Jacobson

Commander
Air Force Aero Propulsion Laboratory, AFSC
Wright-Patterson AFB, OH 45433
Attn: Lester Small 1TBC

Commander
Air Force Avionics Laboratory
Wright-Patterson AFB, OH 45433
Attn: RWN-2, Richard Jacobs

Director
Air Force Office of Scientific Research
1400 Wilson Boulevard
Arlington, VA 22209
Attn: NE, Mr. George Knausenberger

Commander
Air Force Flight Dynamics Laboratory
Wright-Patterson AFB, OH 45433
Attn: AFFDL/FGL, H. Snowball

Commander
Air Force Weapons Laboratory, AFSC
Kirtland AFB, NM 87117
Attn: SUL, Technical Library

Commander
Armament Development and Test Center
Eglin Air Force Base, FL 32542
Attn: ADTC (DLOSL), Technical Library

Air Force Flight Test Center
6510 ABG/SSD
Edwards AFB, CA 93523
Attn: Technical Library

Air Force Institute of Technology, AU
Wright-Patterson AFB, OH 45433
Attn: Library AFIT(LD),
Building 640, Area B
Attn: AFIT(ENM), Milton E. Franke

Aerospace Medical Division
Brooks AFB, TX 78235
Attn: AMD/RDN, Cpt. G. James

Division of Reactor Research and Development
F-309 USERDA
Washington, D.C. 20545
Attn: Frank C. Legler

Oak Ridge National Laboratory
Central Research Library
Building 4500N, Room 175
P.O. Box X
Oak Ridge, TN 37830
Attn: E. Howard

Department of HEW
Public Health Service
National Institute of Health
Building 13, Room 3W-13
Bethesda, MD 20014
Attn: C. J. McCarthy

Department of Commerce
Bureau of East-West Trade
Office of Export Administration
Washington, D.C. 20230
Attn: Walter J. Rusnack

Scientific Library
U.S. Patent Office
Washington, D.C. 20231
Attn: Mrs. Cureton

Department of Commerce
National Bureau of Standards
Washington, D.C. 20234
Attn: Gustave Shapiro, 425.00

NASA Ames Research Center
Moffett Field, CA 94035
Attn: MS 244-13, Dean Chisel

NASA Langley Research Center
Hampton, VA 23665
Attn: MS 494, H. D. Garner
Attn: MS 494, R. R. Hellbaum
Attn: MS 185, Technical Library

NASA Lewis Research Center
21000 Brookpark Road
Cleveland, OH 44135
Attn: Vernon D. Gebben

NASA Scientific and Technical Information Facility
P.O. Box 8657
Baltimore/Washington International Airport, MD 21240
Attn: Acquisitions Branch

U.S. Army Electronics Research and Development Command
Attn: Robert S. Wiseman, DR., DRDEL-CT
Attn: PAO

Harry Diamond Laboratories
Attn: 00100, Commander/Technical DIR/TSO
Attn: Chief, 00210
Attn: Chief, DIV 10000
Attn: Chief, DIV 20000
Attn: Chief, DIV 30000
Attn: Chief, DIV 40000
Attn: Chief, LAB 11000
Attn: Chief, LAB 13000
Attn: Chief, LAB 15000
Attn: Chief, LAB 22000
Attn: Chief, LAB 21000
Attn: Chief, LAB 34000
Attn: Chief, LAB 36000
Attn: Chief, LAB 47000
Attn: Chief, LAB 48000
Attn: Record Copy, 94100
Attn: HDL Library, 41000 (5 copies)
Attn: HDL Library, 41000 (Woodbridge)
Attn: Chairman, Editorial Committee
Attn: Technical Reports Branch, 41300
Attn: Legal Office, 97000
Attn: C. Lanham, 00210
Attn: B. Willis, 47400
Attn: Chief, 13400
Attn: J. Goto, 13400 (5 copies)

Commander
Pacific Missile Range
Naval Missile Center
Point Mugu, CA 93042
Attn: Code 3123, Abe J. Garrett
Attn: Code 1243, A. Anderson