

AD-A064 327

MALLORY BATTERY CO TARRYTOWN N Y
PRIMARY LITHIUM ORGANIC ELECTROLYTE BATTERY BA-5090 ()/U, BA-5--ETC(U)
DEC 78 J BARRELLA, M KUMBHANI

F/G 10/3

DAAB07-76-C-1735

DELET-TR-76-1735-F

NL

UNCLASSIFIED

1 OF 2

AD
A064327

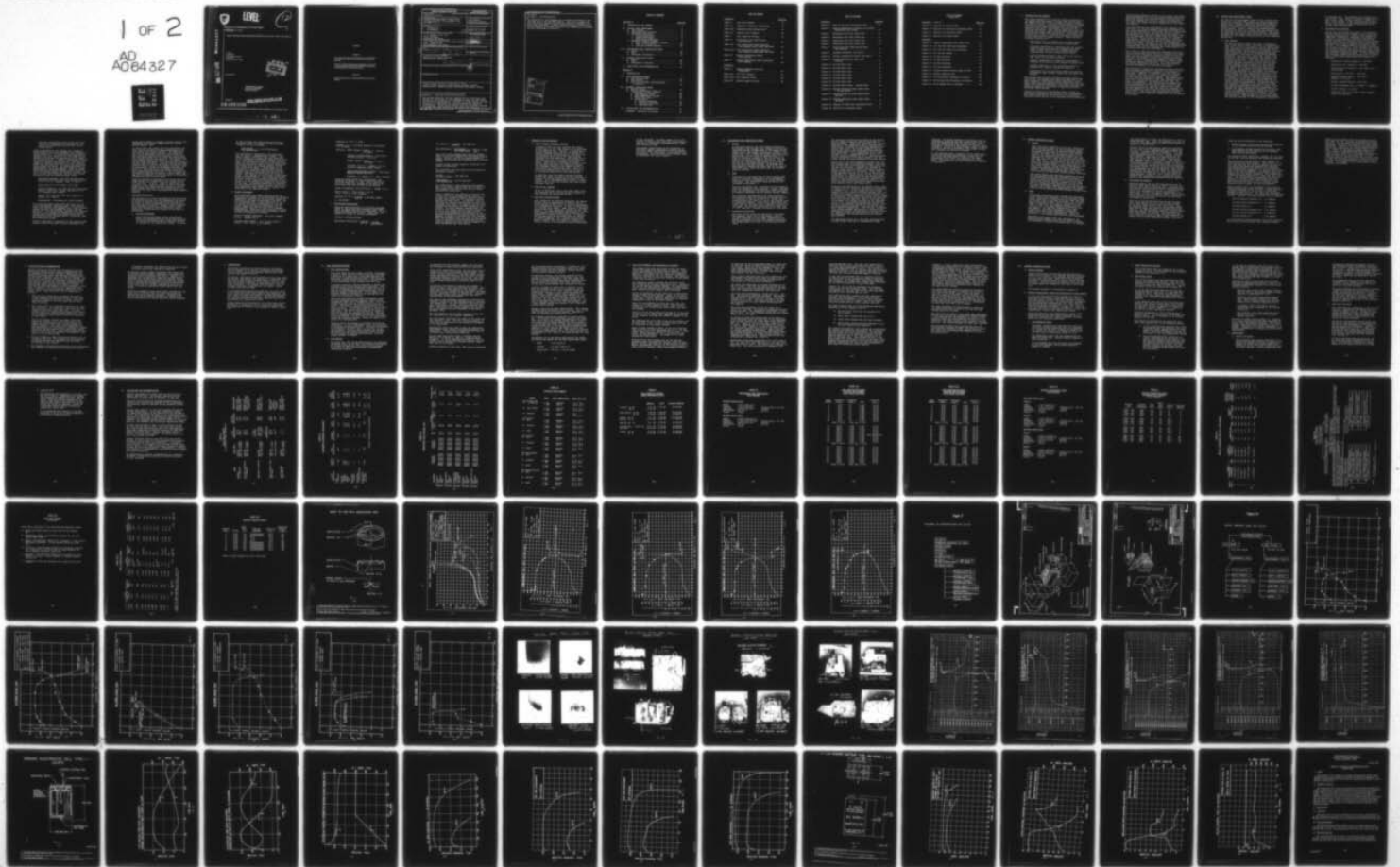

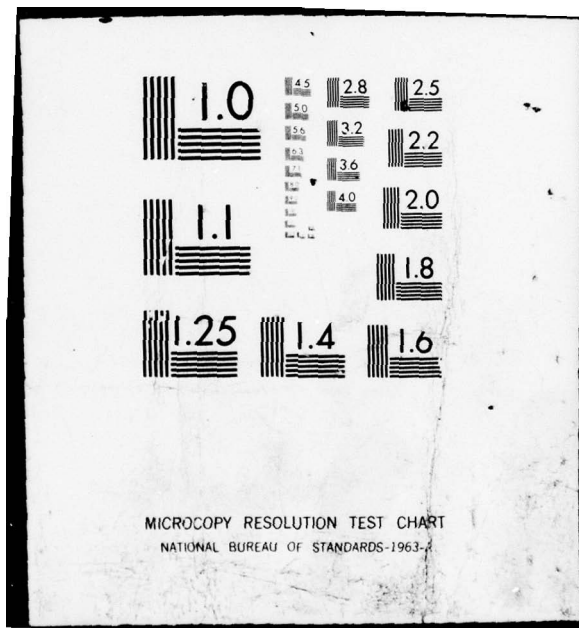

MICROCOPY RESOLUTION TEST CHART
NATIONAL BUREAU OF STANDARDS-1963-A



LEVEL

12

Research and Development Technical Report
ERADCOM - 76 - 1735 - F

ADA 064327

PRIMARY LITHIUM ORGANIC ELECTROLYTE BATTERY BA - 5090 ()/U, BA - 5585 ()/U, BA - 5598 ()/U

J. Barrella
M. Kumbhani
Mallory Battery Company
60 Elm Street
North Tarrytown, NY 10591

DDC FILE COPY

DDC
RECEIVED
FEB 7 1979
C

December 1978

DISTRIBUTION STATEMENT
Approved for public release;
distribution unlimited

Prepared for

ERADCOM

ORIGINAL CONTAINS COLOR PLATES; ALL DDC
REPRODUCTIONS WILL BE IN BLACK AND WHITE

US ARMY ELECTRONICS RESEARCH & DEVELOPMENT FORT MONMOUTH, NEW JERSEY 07703

79 02 05 091

NOTICES

Disclaimers

The findings in this report are not to be construed as an official Department of the Army position, unless so designated by other authorized documents.

The citation of trade names and names of manufacturers in this report is not to be construed as official Government indorsement or approval of commercial products or services referenced herein.

Disposition

Destroy this report when it is no longer needed. Do not return it to the originator.

REPORT DOCUMENTATION PAGE		READ INSTRUCTIONS BEFORE COMPLETING FORM
1. REPORT NUMBER DELET-TR-76-1735-F ¹	2. GOVT ACCESSION NO.	3. RECIPIENT'S CATALOG NUMBER
6 4. TITLE (and Subtitle) Primary Lithium Organic Electrolyte Battery BA-5090()/U, BA-5585()/U, BA-5598()/U,	5. TYPE OF REPORT & PERIOD COVERED Final Report 5/1/76 to 12/30/78	
	6. PERFORMING ORG. REPORT NUMBER	
7. AUTHOR(s) 10 J./Barrella M./Kumbhani	15	8. CONTRACT OR GRANT NUMBER(s) DAAB07-76-C-1735
9. PERFORMING ORGANIZATION NAME AND ADDRESS P. R. Mallory & Co. Inc. South Broadway Tarrytown, NY 10591	10. PROGRAM ELEMENT, PROJECT, TASK AREA & WORK UNIT NUMBERS 12 113 P.	
11. CONTROLLING OFFICE NAME AND ADDRESS U.S. Army Elct Tech & Dvcs Laboratory 11 Attn: DRSEL-TL-TD Fort Monmouth, NJ 07703	12. REPORT DATE Dec 1978	
14. MONITORING AGENCY NAME & ADDRESS (if different from Controlling Office) 9 Final rept. 1 May 76 - 3p Dec 78,	13. NUMBER OF PAGES	
	15. SECURITY CLASS. (of this report)	
16. DISTRIBUTION STATEMENT (of this Report) Approved for Public Release; Distribution Unlimited 18 DELET		15a. DECLASSIFICATION/DOWNGRADING SCHEDULE 19 76-1735-F
17. DISTRIBUTION STATEMENT (of the abstract entered in Block 20, if different from Report) 7R		
18. SUPPLEMENTARY NOTES		
19. KEY WORDS (Continue on reverse side if necessary and identify by block number) Sulfur Dioxide Battery, Hermetically Sealed, Lithium, Balanced Cell, Abuse Testing, Electrode Efficiency, Safety		
20. ABSTRACT (Continue on reverse side if necessary and identify by block number) Section 1 - BA-5598 and BA-5585 Batteries The primary objective of this program was to investigate the effects of variations of cell component ratios on cell safety and electrical performance. Included in these studies was the evaluation of potential vent design changes for capacity optimization. Hermetically sealed cells and batteries already in production were utilized as the basic test vehicles.		

20. cont.

Section 2 - BA-5090 Battery

The objective of this program was to design and develop a new cell for use in the BA-5090 battery. Due to its unique size this L037S cell required special manufacturing techniques not previously developed. Primary concern throughout this section was to maximize utilizable capacity while complying with design criteria developed in Section 1.

ACCESSION for	
NTIS	Write Section <input checked="" type="checkbox"/>
DOC	Buff Section <input type="checkbox"/>
UNANNOUNCED	<input type="checkbox"/>
JUSTIFICATION	<input type="checkbox"/>
BY	
DISTRIBUTION/AVAILABILITY CODES	
Dist.	Special
A	

TABLE OF CONTENTS

<u>Section 1</u>	<u>Page No.</u>
I. INTRODUCTION AND SUMMARY	1
II. INITIAL CELL DEVELOPMENT	3
A. Vent Designs	3
B. Unbalanced Cell Testing	4
C. Electrode Efficiency	6
1. Lithium Efficiency	6
2. Carbon Efficiency	7
3. Electrolyte Efficiency	8
D. Component Limited Designs	
1. Case I Carbon (Cathode) Limited	10
2. Case II SO ₂ Limited	10
3. Case III Lithium Limited	10
III. PRELIMINARY CELL FABRICATION PHASE	
A. Design	12
B. Test	12
C. Discussion of Results	12
IV. BATTERY FABRICATION PHASE	
A. Design	15
B. Test	15
C. Discussion of Results	16
V. CONCLUSIONS AND RECOMMENDATIONS	19
 <u>Section 2</u>	
I. INTRODUCTION	21
II. CELL FABRICATION PHASE	
A. Cell Construction	22
B. Cell Design	22
C. Cell Test Program, and Discussion of Results	25
III. BATTERY FABRICATION PHASE	
A. Battery Design	29
B. Battery Fabrication, Tests and Discussion of Test Results	29
1. Environmental Tests	29
2. High Temperature Storage	30
3. Electrical Tests	30
4. Safety Tests	
a. Reverse Discharge	31
b. High Rate Discharge	32
c. Charging Test	33
IV. CONCLUSIONS AND RECOMMENDATIONS	34
APPENDIX - Technical Guidelines	89

LIST OF TABLES

<u>Section 1</u>		<u>Page No.</u>
Table I	Vent Test Summary	35
Table II	Component Volumetric Efficiency	36
Table III	Unbalanced Cell Designs LO25	37
Table IV	Capacity Test Summary	38
Table V	Cell Capacity Testing	39
Table VI	Preliminary Cell Fabrication Cell Designs	40
Table VII	Cell Fabrication Phase Capacity Test Summary LO25S Cells (BA-5598) .	41
Table VIII	Cell Fabrication Phase Capacity Test Summary LO30S Cells (BA-5585) .	42
Table IX	Battery Fabrication Phase Cell Designs	43
Table X	Battery Fabrication Phase Discharge Test Summary	44
 <u>Section 2</u>		
Table XI	Design Parameters and Cell Performance	45
Table XII	Cell Test Program	46
Table XIII	Cell Capacity Tests	48
Table XIV	Battery Capacity Tests	49

LIST OF FIGURES

<u>Section 1</u>	<u>Page No.</u>
Figure 1 Base of Can with Convolution Vent	50
Figure 2 Typical Temperature Profiles of Critical Unbalanced Cell Groups	51
Figure 3 Unbalanced Cell Test L025S Cell	52
Figure 4 Unbalanced Cell Test L025S Cell	53
Figure 5 Unbalanced Cell Test L025S Cell	54
Figure 6 Unbalanced Cell Test L025S Cell	55
Figure 7 Preliminary Cell Fabrication Phase Test Outline	56
Figure 8 Assembly BA-5598/U, SCS 459/12	57
Figure 9 Battery Assembly BA-5585/U, SCS 459/3	58
Figure 10 Battery Fabrication Phase Test Outline	59
Figure 11 BA-5598 Abuse Test	60
Figure 12 BA-5598 Abuse Test	61
Figure 13 BA-5598 Abust Test	62
Figure 14 BA-5585 Abuse Test	63
Figure 15 BA-5585 Abust Test	64
Figure 16 BA-5585 Abuse Test	65
Figure 17 Battery Abust Tests - During Tests	66
Figure 18 Battery Condition After Abuse Tests 1.38 Amp Charge	67
Figure 19 Battery Condition After Abuse Tests BA-5585	68
Figure 20 Battery Condition After Abuse Tests BA-5598	69
Figure 21 Typical C/2 High Rate Discharge L025S	70
Figure 22 Typical C/3 Discharge L025S	71

LIST OF FIGURES
Continued

<u>Section 1</u> - Cont'd.	<u>Page No.</u>
Figure 23 Typical C/5 Charge L025S	72
Figure 24 Typical C/2 High Rate Discharge L030S .	73
Figure 25 Typical C/3 Discharge L030S	74
Figure 26 Typical C/5 Charge L030S	75
 <u>Section 2</u>	
Figure 27 Organic Electrolyte Cell Type L037S . .	76
Figure 28 C/3 (142 mA) High Rate Discharge	77
Figure 29 C/2 (213 mA) High Rate Discharge	78
Figure 30 C/5 (85 mA) Charge	79
Figure 31 25 Ohm Discharge	80
Figure 32 75 Ohm Discharge	81
Figure 33 155 Ohm Discharge	82
Figure 34 250 Ohm Discharge	83
Figure 35 Lithium Organic Battery Type BA-5090 . .	84
Figure 36 Battery Capacity Test	85
Figure 37 133 mA Reverse Discharge on Battery . .	86
Figure 38 200 mA High Rate Discharge on Battery .	87
Figure 39 80 mA Charge Test on Battery	88

I. INTRODUCTION AND SUMMARY

This report documents the technical efforts conducted by the Mallory Battery Company in compliance with Contract No. DAAB07-76-C-1735. The provisions of subject contract required the design, development and manufacture of three cell and battery types which would meet the appropriate electrical and safety requirements set forth in the Technical Guidelines. This section deals with two of the three battery types, namely, the BA-5598 and BA-5585 and the L025S and L030S cells respectively. Originally this contract was to span 13 months and encompass a multitude of cost reduction and safety projects. These projects included evaluation of:

- Electrolyte fill on underside of can using welded fill eyelet instead of fill tube in glass seal.
- Alternate materials as a substitute for the present glass to metal seal such as a thermoplastic seal fused to steel eyelet and an aluminum terminal (fluorocarbon and other plastic bonded seals).
- Various welding methods to seal top to can such as TIG, laser and resistance welding.
- Possible replacement of tantalum by molybdenum or titanium as the positive feed through to reduce cost.
- Possible reduction in vent convolution height to increase cell internal volume and capacity.
- Optimization of cell design for safety and capacity performance under extreme temperature and abuse conditions.

The contract was initially divided into three phases; an Initial Cell Development Phase which included all of the above projects, a Preliminary Design Fabrication Phase which tested the most promising cell design from the first phase, and a Battery Fabrication Phase which utilized the successful Phase II cell design in completed batteries with minor modifications.

During the Initial Cell Development Phase a change in contractual requirements was initiated by the Government. This change resulted in redirection of our activities-- deleting a major portion of the programs outlined above and

concentrating Mallory's efforts in cell safety and performance optimization and vent convolution height reduction. Extensive efforts were directed toward isolating the primary cell components related to safety and identifying the effects of changes of these components on cell safety and capacity.

During the Initial Cell Development Phase numerous cells were made with varying component designs to determine the most viable approach to a safer more efficient cell design. The BA-5598 cell, LO25S, was used as the test vehicle. Approximately 300 cells were fabricated and tested. Testing included short circuit, charge, high rate discharge with forced voltage reversal and capacity at various temperatures. Based on the results of these tests ECOM selected a design to be used for the Preliminary Cell Fabrication Phase. However, at the time of selection all safety testing was not completed due to the aforementioned increased scope and the selection was based primarily on the merits of electrical performance.

Sixty cells of each type were then fabricated and tested for the Design Fabrication Phase in accordance with paragraph 4.0 of the Technical Guidelines while 40 cells of each type were shipped to ECOM for separate evaluation. Testing at the Mallory Battery Company included 30 days storage at 160°F, complete environmental testing regime, safety and capacity evaluations. All cells tested met all program objectives and in all cases the required capacity performance was achieved or exceeded.

Upon approval of these tests and data by ECOM the Mallory Battery Company proceeded to fabricate 45 batteries of each type as required in paragraph 5 of the Technical Guidelines. However, in light of safety test results, one half of each type battery was made with thinner lithium anode per Government request. More specifically, one half of the batteries of each type contained cells with .010" lithium and the other half with .008" for safety consideration. All batteries had undergone complete environmental testing and 10 days at 160°F prior to electrical testing. Batteries were tested at high and low temperature extremes for capacity, underwent reverse discharge at the C/2 and C/3 rates and charging at the C/5 rate. The safety vent worked under all abuse conditions, and the electrical performance was as expected in all tests.

II. INITIAL CELL DEVELOPMENT PHASE

The Initial Cell Development Phase of this contract originally was to utilize four months and contain studies on bottom fill techniques, substitute glass seal materials, bonded seals, welding methods and terminal feed through changes in addition to the evaluation of new vent and safety designs. However, early in the program Mallory was directed to delete all studies from the contract with the exception of new vent and safety designs. Ten months of study was then concentrated on the new vent and safety designs with the primary attention given to cell component evaluation.

A. Vent Designs

The Mallory Battery Company utilizes a convolution vent in all Li/SO₂ cells. This vent is integral with each cell can and is intended to relieve over pressurized conditions in cells and thus the possibility of explosions and/or ruptured cans is minimized. This design involves the use of two diametrically opposed convolutions in the base of the nickel plated steel container. There are two notches 180° apart at the meeting of these two convolutions (see Figure 1 for a sketch of the area). The center portion of the convolutions acts as a motor disc and as the cell's internal pressure increases the disc tends to move outward applying stress primarily at the notches (the convolutions tend to yield and unfold at the same time). At the point of venting the notched section(s) have reached a stage where they begin tearing open allowing the cell gasses to be expelled and relieving the over pressurized condition. The height (shape) of these convolutions diminishes the utilizable cell internal volume and electrode width. An increase of one or both of these parameters (internal volume, electrode width) would allow for improved electrical performance. During this phase of the contract a reduction of the convolution height was explored to determine the merits, if any, of reductions in height versus capacity improvement and related vent characteristics. Variations of 50% and 75% of the standard convolution height were tested using the LO26S cell as the test vehicle. Short circuit and incineration tests at 1,000°F were used for evaluation. Both changes in vent design heights, 50% and 75%, resulted in cell explosions, bulged and/

or ruptured cans. The standard vent operated with only a quiet hiss. Table I contains a summary of the cell tests. Based on these results no change was made in the design. It was concluded that a change in the vent structure would be unfeasible and no further work was performed.

B. Unbalanced Cell Testing

During this preliminary work phase of the contract Mallory exerted its major effort on cell safety and component optimization. Numerous cell designs and tests were conducted to investigate the effects of changes in cell component ratios on capacity and safety performance. The basic intent of this program was to alter the cell balance by both increasing and decreasing the relative amounts of lithium, carbon and SO₂. The standard L025S cell design was used as the control test vehicle. Since internal cell volume is the basic capacity constraint for all Li/SO₂ cells, this parameter along with cathode current density was kept constant whenever possible. In this discussion the following assumptions and ground rules have been made to facilitate calculations and maintain consistency:

- Theoretical lithium capacity = 3.86 AH/g
- Theoretical SO₂ capacity = .418 AH/g
- L025S rated cell capacity = 10.0 AH/at 75°F, 24 hour rate
- Electrolyte at 70% SO₂ = .293 AH/g
- Cathode aluminum exmet = .072 g/in.²
Density = 2.71 g/cc
- Typical cathode density = 1.97 g/cc
- 24 hour discharge rate = 7Ω load = .4 amperes
- Cutoff voltage = 2.0 volts
- Discussion will be limited to data compiled under this contract.

- The term "electrolyte" used in this text will refer to the combination of depolarizer (SO₂) and actual electrolyte (AN and LiBr) as one common entity.

Before proceeding to cell designs the volumetric efficiencies of each cell component were required to assure proper fit. It should be noted that approximately a 10% void volume at 75°F was sought on all designs to allow for SO₂ expansion at high temperature storage (160°F+). Table II defines the relative volumetric efficiencies of each cell component with respect to capacity attainable (75°F and 1 mA/cm²). These were the basis for calculating the unbalanced design changes to follow. An excess/deficiency of approximately 30% of one component from the control constituted an unbalanced design. Table III summarizes the design changes and variables studied. Two cells of each type along with controls were tested for safety using the following abuse tests:

High Rate Discharge - C/2 rate for twice the rated cell capacity taken into voltage reversal at 75°F (C/2 = 5 amperes) (time = 4 hours).

Short Circuit at 75°F using <.01Ω load

Reverse Discharge - C/3 rate for twice the rated capacity taken into voltage reversal at 75°F (3.33 amperes for 6 hours).

Charge - C/5 rate for rated cell capacity (2 amperes for 5 hours)

Incineration - 15 minutes at 1,000°F minimum

All safety and abuse tests were conducted in a specially constructed "explosion room". This room is lined with Transite and equipped with a high velocity exhaust facility and scrubber to control noxious gasses etc. All switching and controls were remotely operated. Cell voltage and temperature along with current were continuously monitored using a Gould multiposition strip recorder and/or a Fluke No. 2240 data acquisition system.

Figure 2 represents a comparison of the typical temperature rises of the most critical unbalanced cell

groups while Figures 4 through 6 reflect typical cell discharges with voltage, temperature and current plotted against time.

As can be seen, the groups with low electrolyte and high lithium resulted in maximum temperature rises when forced into voltage reversal. In addition to the rate of temperature increase, these cells not only vented but caught fire a majority of the time. The only group which did not catch fire when brought into voltage reversal was group 5A, low lithium. The reason and/or explanation for this is presented in the discussion to follow. This data was not available, however, when ECOM chose the design for the Cell Fabrication Phase. Group 7C was chosen therefore; based on its superior electrical performance as noted in Table IV. Once the data on the above safety tests were reported changes were made to the 7C design for the Battery Phase of the project. These changes and specific cell designs will be discussed in the Battery Fabrication Phase of this report.

Capacity evaluation consisted of two cells from each group (Table III) discharged at the 24 hour rate at 75°F and -40°F (7 Ω load). Table IV summarizes the capacity tests. From this table it can be seen that groups #7C, High Carbon Cathode Alternate, and #3C, High Cathode, delivered the best combination of capacity at 75°F and -40°F with group #7C being slightly superior.

C. Electrode Efficiency

The following is a brief discussion of the electrical efficiencies derived from the unbalanced cell groups. In order to calculate meaningful efficiencies the data must be taken from groups which were limited by the electrode in question. Namely, lithium limited cells for determining lithium efficiency, carbon limited for cathode and SO₂ limited in the case of electrolyte.

1. Lithium Efficiency

Basic lithium efficiency can be calculated by taking the unbalanced groups which were deficient in lithium and determining the capacity derived in relation to its theoretical figure. In group

5A (low lithium) the lithium was the limiting electrode, where 2.63 grams of lithium yielded 7.8 AH at 75°F or 2.96 AH/g.

$$\frac{2.96 \text{ Actual}}{3.86 \text{ Theoretical}} = 76.7\% \text{ Efficiency}$$

For convenience a conservative 75% efficiency will be used as a representative number. This anode (lithium) efficiency will vary from cell to cell depending on electrode geometry and thickness. The present cell design utilizes lithium which is cold welded to the can at the end of the strip and contains no tabs or current collectors. The lithium is on the external portion of the cell (jelly roll) wrap. A large degree of inefficiency is caused by this external, nonconsumable, wrap of lithium where one half of that external wrap does not enter into the cell reaction. This amounts to a 8.1% loss in efficiency before discharge begins. The lithium efficiency could be increased if a current collector were to be used, if more than one tab were placed on the strip or if the cathode was located on the outside of the wrap. Utilization could also be improved by using shorter and thicker lithium, but the cell rate capability would suffer due to surface area reduction of the opposing cathode.

2. Carbon Efficiency

To be meaningful the carbon efficiency must be specified with respect to current density, discharge temperature, porosity of the structure, amount of electrolyte and type of electrolyte utilized. For ease of presentation, current densities of .88 - 1.1 mA/cm² will only be considered in this discussion along with 70% SO₂ electrolyte, 84.5% porous carbon and both 75°F and -40°F discharge temperatures. Using data from discharges on group 7A where carbon was the limiting electrode, calculations are presented as follows:

Group 7A Cathode Dimensions - 21"x.033" nominal x 1.35". Weight 6.4 g.

Aluminum exmet weight - .072 g/in²x1.35"x21" = 2.04 g. 6.4 - 2.04 = 4.26 g carbon.

Capacity at 75°F = 7.9 AH.

$$\frac{7.9 \text{ AH}}{4.36 \text{ g carbon}} = 1.81 \text{ AH/g carbon at } 1.09 \text{ mA/cm}^2$$

$$\text{Porosity - Exmet Volume} = \frac{2.04 \text{ g}}{2.71 \text{ g/cc}} = .752 \text{ cc}$$

$$\text{Apparent Cathode Volume} = 1.35" \times .033" \times 21" \times 16.39 \text{ cc/in.}^3 = 15.33 \text{ cc}$$

$$\text{Carbon Volume} = \frac{4.36 \text{ g}}{1.97 \text{ g/cc}} = 2.21 \text{ cc}$$

$$(\text{Cathode}) 15.33 \text{ cc} - (\text{Exmet}) .752 \text{ cc} = 14.578 \text{ cc apparent Carbon Volume}$$

$$\frac{\text{Actual Solid Volume } 2.21 \text{ cc}}{\text{Apparent Volume } 14.578 \text{ cc}} = .1515 \text{ solid}$$

$$\text{Porosity} = 1 - \text{solid} = 1 - .1515 = 84.85\%$$

Using the above method for calculations, the porosity in groups 5, 6 and 7 varied from 84.2% to 84.9% while that in group 3A was only 80.1%. Efficiency from this cathode was as follows:

Group 3A dimensions 26"x.023"x1.35". Weight 7.5 g.

$$\text{Exmet weight} = .072 \times 1.35 \times 26 = 2.53 \text{ g.}$$

$$7.5 \text{ g} - 2.53 \text{ g} = 4.97 \text{ g carbon}$$

$$\text{Capacity at } 75^\circ\text{F} = \frac{9.36 \text{ AH}}{4.97 \text{ g}} = 1.88 \text{ AH/g carbon}$$

at .88 mA/cm²

3. Electrolyte Efficiency

Group 6A (low electrolyte) is the most desirable group to compute the SO₂ efficiency since these cells were most deficient in electrolyte. At 75°F capacity obtained was 7.46 AH. These cells contained 25.7 grams of 70% SO₂ electrolyte:

$$(25.7 \times .7 = 17.99 \text{ g of SO}_2)$$

$$\text{Electrolyte Efficiency} = \frac{7.46 \text{ AH}}{25.7 \text{ g}} = .29 \text{ AH/g electrolyte}$$

$$\text{SO}_2 \text{ Capacity} = \frac{7.46 \text{ AH}}{17.99 \text{ g}} = .414 \text{ AH/g SO}_2$$

$$\text{SO}_2 \text{ Efficiency} = \frac{.414 \text{ Actual}}{.418 \text{ Theoretical}} = 99\% \text{ at } .4 \text{ amp rate}$$

Since the control groups were also SO₂ limited they too are valid samples for efficiency calculations. In fact, due to the greater number of samples these may be more representative of actual yields.

Control groups average capacity 9.9 AH for 35.0 grams of electrolyte.

The efficiency for this group can be calculated identical to above:

$$\frac{9.9 \text{ AH}}{(35.0 \times .7) \text{ g SO}_2} = .404 \text{ AH/g SO}_2$$

$$\frac{.404 \text{ Actual}}{.418 \text{ Theoretical}} = 96.6\% \text{ Efficient}$$

This efficiency is more realistic and accurate due to the greater sample size than in group 6A. This number 96.6% will be used for any future optimization trade-offs.

Table V summarizes the capacity of various cell groups relative to cathode current density. As a result of the above capacity tests and data, designs were chosen for the Preliminary Design Fabrication Phase cells. In addition, data reflecting the relative efficiencies of each cell component with respect to capacity and rate were accumulated and used to develop subsequent cell designs. In these designs, consideration was given to cell safety and why lithium limited had no fires when brought into voltage reversal. The following paragraphs are presented as one possible explanation why limited cells are advantageous in helping to prevent cell fire hazards. Heat and discharge rates are also critical parameters in relation to cell hazards and the conjectured explanation below must be tempered with those parameters when scrutinized.

D. Component Limited Designs

1. Case I Carbon (Cathode) Limited

If carbon limits the cell reaction the excess lithium was, at one time, thought to be protected by the remaining SO_2 . However, in situations of forced discharge where the cell is forced into voltage reversal and discharge is continued, the cell normally vents due to the high internal impedance and heat generated. This condition is identical to a cell in a battery pack where one cell is prematurely discharged for whatever reason. When the SO_2 is allowed to escape (vent) and discharge continues the remaining lithium (hot) becomes exposed to the organic solvent in the electrolyte, acetonitrile (AN). This is a likely fire hazard since lithium and AN can react violently together and also form methane.

In addition, once the carbon electrode becomes blocked and cannot sustain the Li/SO_2 reaction to $\text{Li}_2\text{S}_2\text{O}_4$ the lithium itself may be plated on the cathode. This electrodeposited lithium is highly reactive due to the high surface area and is very hazardous with AN.

2. Case II SO_2 Limited

If SO_2 is deficient, Case I may again apply since the remaining AN and lithium would be allowed to react without the protection of SO_2 .

3. Case III Lithium Limited

With lithium as the limiting electrode, the hazard of cell fires or explosions is likely to be reduced because lithium is one of the two consumables of the exothermic reaction. In fact, lithium alone is a serious fire threat. When lithium is consumed ahead of the other electrodes (carbon and SO_2) the change in its physiochemical characteristics renders this component less hazardous and minimizes the changes of a lithium to AN reaction. In addition the lithium would not be plated onto the cathode in forced discharge. In a lithium limited cell design, however, the cell capacity at ambient low rates is likely to be reduced by overall efficiency

of the electrode. The exact amount of this reduction in capacity and resulting safety enhancement must be thoroughly investigated and a complete trade-off made.

With proper proportioning of all parameters an equivalent ambient performance could be reached with only slight degradation of cold temperature performance. This and other investigations would be applicable for future studies.

III. PRELIMINARY CELL FABRICATION PHASE

A. Design

As mentioned earlier, the cell designs utilized in this phase of the contract were selected from various unbalanced groups by ECOM prior to the completion of safety tests. The design incorporated thinner (.010" rather than .012") lithium and longer electrodes while maintaining a Li:SO₂ ratio of approximately 1:.72. Table VI contains a summary of the cell designs as made and the relative range of variations. In both designs the lithium was cold welded to the side of the can and a tantalum tube used as both the fill port and positive feed through. No problems were experienced in fabrication other than in the case of the LO30S cells, where the jelly roll fit slightly tight in the can.

B. Test

Following fill and three days at 160°F storage both sets of cells were subjected to the environmental tests as outlined in paragraph 3.6 of the Technical Guidelines. For convenience these guidelines are contained in Enclosure I.

Stanford Technology Corp. performed all environmental tests for Mallory on this contract. Figure 7 outlines both the environmental and electrical tests performed by Stanford Technology and the Mallory Battery Company.

The electrical performance of all cells surpassed that required under the Technical Guidelines and data is contained in Tables VII and VIII. Weight loss determinations were made over the 30 day storage using an analytical balance. The BA-5598, LO25S cells had a mean loss of .010 gram with a standard deviation of .003 gram. The BA-5585, LO30S cells had a mean loss of .0097 gram and a standard deviation of .0344 gram.

C. Discussion of Results

Both lots of 100 cells were subjected to the above environmental tests with no detrimental effects. The data contained in this report demonstrates the design as proposed will meet the required mechanical and thermal abuse set forth in the Technical Guidelines.

All electrical testing was performed by the Mallory Battery Company's Quality Control Department at North Tarrytown. Every cell tested met the required capacity at each temperature and no problems were experienced. Although the electrode parameters and Li:SO₂ ratio on the cell design selected was not optimum for safety, the design exhibited excellent cold temperature (-40°F) performance after 30 days storage at 160°F. Approximately 66% of the 75°F service life was obtained at -40°F. This can primarily be attributed to the longer cathode with high carbon content and more efficient use of the lithium.

During the 30 day high temperature storage only one cell showed signs of electrolyte leakage. This cell was an L030S type which developed a leak between the top and can rim weld. Although this leakage was slight, steps have been taken to minimize the possibility of poor welds in the future. These steps include improving the seat of the top to the can prior to welding and a closer scrutiny of the welds after fabrication. An additional two week waiting period prior to battery fabrication has been implemented to assist in the screening of potential leakers. All cells for the Battery Fabrication Phase of this program underwent these additional checks.

Graphical representations of the typical safety tests as required by the Technical Guidelines are contained in Figures 21-26. In each graph the cell voltage, temperature, and current is plotted against time. Included is the time of cell venting and notations depicting any abnormal happenings, such as fires, sparks or explosions. During both tests where the cells were taken into voltage reversal, sparks, fires and venting occurred at or about the point of SO₂ exhaustion in the cell. One possible explanation for this behavior is the reaction between AN and lithium. This has been mentioned earlier in this report but this point should be emphasized. Once the cell is brought into voltage reversal and current is forced in the discharge direction, lithium begins to be plated onto the cathode instead of combining with the SO₂. At SO₂ exhaustion the lithium plating action becomes more primary.

The deposited lithium is a very fine structure with a large surface area and is subsequently highly

reactive. As forced discharge is continued, heat is continually generated and the lithium finally reacts with the remaining AN from the electrolyte. This reaction can be violent and results in venting, fires or sparks. Because the above designs result in excess lithium at the end of discharge, this unused lithium also enhances the severity of hazard.

In the charging tests, a majority of the L025S units vented and exploded approximately 3 hours into the test while the L030S cells, charged at the same proportional rate (C/5), did not even vent after 5 hours. No explanation for the difference in behavior is available.

IV. BATTERY FABRICATION PHASE

A. Design

After successful completion of the Cell Fabrication Phase and upon approval of the Preliminary Design and Visualization Plan the Mallory Battery Company fabricated 46 batteries of each type (BA-5598 and BA-5585) for ECOM. Per Government request and in light of the aforementioned safety tests just then completed one half of each lot of cells and batteries were made with .010" thick lithium and the other half with .008" thick. The purpose of this change was to reduce the lithium content in the cells in such a way as to have minimum impact on cell performance and yet lean toward safety. Volume saved by the thinner lithium was compensated with an equal volume of electrolyte. These changes reduced the Li:SO₂ ratio while maintaining equivalent cathode current densities.

The actual designs and electrode parameters utilized for each battery design are contained in Table IX. The BA-5598 battery consists of five L025S cells connected in series and protected by a slow blow fuse. The BA-5585 battery, however, consists of ten L030S cells in series also fuse protected. During all of the tests conducted at Mallory the fuses were bypassed. Figures 8 and 9 depict the configurations and dimensions of the BA-5598 and BA-5585 batteries respectively.

B. Test

Testing for this phase of the contract was performed in accordance with paragraph 5 of the Technical Guidelines. Originally 45 batteries of each type (BA-5598 and BA-5585) were to be made and tested, 25 at Mallory and 20 delivered to ECOM. Due to the change in the number of batteries and different designs (lithium .008" vs .010") the exact quantity of batteries were not tested to the specific requirements at each environment. Per mutual agreement a compromise number of batteries were fabricated and tested to best evaluate the overall performance. Figure 10 contains a block diagram depicting the tests performed.

Electrical and storage tests were performed at the Mallory Battery Company while the environment portion was performed at Stanford Technology Corp. No problems

were experienced in either the fabrication or test of either battery type. After environmental testing all batteries were subjected to 10 days at 160°F prior to capacity or safety tests.

Capacity tests on both battery types were performed at 130°F and -20°F to appropriate pulse regimes for each unit. BA-5598 required discharge at 14.2Ω for 2 minutes followed by 291Ω for 18 minutes. AB-5585 pulse discharge requires 39Ω for 1 minute and 560Ω for 9 minutes. Eight ohms was applied during the first 100 ms of each 1 minute load. These cycles were repeated until the 10.0 and 20.0 volt cutoffs were reached. Table X contains a summary of the electrical performance of each battery type. As shown, the 130°F capacity was better in batteries containing the greater amount of lithium while the cold temperature performance was just the opposite. This can be explained by the fact that at 130°F the lithium was the limiting electrode but at -20°F the cathode becomes limiting. Since the .008" lithium cells had slightly more electrolyte this enhanced the performance of the cathode and resulted in better capacity.

C. Discussion of Results

Required capacity for the BA-5598 batteries was 45 hours at 130°F and 30 hours at -20°F. In every case the delivered capacity exceeded that required by more than 31% at 130°F and 47% at -20°F. The BA-5585 batteries also exceeded the capacity requirements in every case. At 130°F the excess capacity was a minimum of 109% at 130°F and 102% at -20°F. Reference SCS 459/12 and 459/3 for BA-5598 and BA-5585 electrical requirements respectively.

Start-up of the BA-5598 batteries was met in every case. Each battery was up to the 10 volt minimum on the first cycle at 130°F and -20°F tests. This was expected since there are no initial heavy pulses which tend to keep the operating voltage low during start-up. BA-5585 batteries, however, do have a heavy pulse requirement (≈ 7 mA/cm²) and were expected to take a few cycles to start-up. Both the 130°F and -20°F start-up as shown in Table X took excessive (24 cycles) time to reach operating voltage. This slow

start-up can be attributed to two conditions.

1. Excess moisture in the cell causing film formation on the lithium electrode during storage.
2. Questionable cathode conductivity resulting from poor adhesion of the material to the aluminum exmet during fabrication.

The second of these conditions, cathode, was the cause of the slow start-up based on the following rationale.

The first pulse voltage was ≈ 7.2 volts whereas the second pulse rose to 15.4 volts. This initial 7.2 to 15.4 volt jump was the effect of opening the film on the lithium electrode and reflected cell moisture. Continued operation just below 20 volts reflected a high internal cell impedance. It was also later found that at the time of subject cell assembly there was a problem with the cathode operation. This problem exhibited the characteristics of a high cell over potential. The over potential was measured and found to reflect the typical voltage differences that were observed in the batteries. This problem has since been corrected and cells tested at similar current densities do not exhibit any start-up problems.

Battery safety tests were performed on both battery types and followed similar patterns. Tests consisted of forced discharge at the C/2 and C/3 rates and charging at the C/5 rate. All tests were performed at ambient temperatures in the explosion room described earlier. Specific discharge currents were as follows:

BA-5598 Forced Discharge C/2	- 5.0 amperes
BA-5598 Forced Discharge C/3	- 3.3 amperes
BA-5598 Charge C/5	- 2.0 amperes
BA-5585 Forced Discharge C/2	- 2.45 amperes
BA-5585 Forced Discharge C/3	- 2.3 amperes
BA-5585 Charge C/5	- 1.38 amperes

In all batteries forced discharge tests were conducted for twice the rated capacity into voltage reversal.

Results of the battery tests were similar for both the .008" and .010" lithium and BA-5598 and BA-5585 batteries. In all cases the cells/batteries vented then burst into flame with some more or less violent explosions. Figures 11-16 reflect typical discharge curves with temperature and voltage plotted versus time. Figure 17 represents pictures taken of the fires during the aforementioned safety tests on typical units. There was no apparent difference between cells/batteries containing .008" or .010" lithium either in severity of hazard or time it took to reach the hazardous condition. Figures 18-20 are pictures of both type batteries taken after safety testing. It is apparent that these batteries can be hazardous when abused.

V. CONCLUSIONS AND RECOMMENDATIONS

Results of both the Initial Cell Development and Cell Fabrication Phases of this contract demonstrated that the mechanical and safety techniques employed for the Battery Fabrication Phase were the most feasible means of achieving a reliable, safe and efficient design. The use of less lithium and greater SO_2 in the cell designs reflected state of the art techniques developed during this period. Although no significant differences were seen during battery testing with regard to thinner lithium and safety performance the data generated, along with the specific cell inputs of the unbalanced cell tests, resulted in design techniques applicable to all Li/SO_2 cells. These techniques can be summarized as follows:

1. The cell vent mechanism as originally designed is a most reliable and efficient method for relieving an over pressurized situation in cells. This vent operated reliably in all cell types during every abuse situation.
2. The $\text{Li}:\text{SO}_2$ ratio is an important parameter for safe cell operation. The lower the $\text{Li}:\text{SO}_2$ ratio the less likely the hazard of cell fires, etc. No ratio, however small, will completely eliminate the hazards of cell operation under all abuse conditions, (i.e., cell charging or uncontrolled forced over discharge at high rates).
3. The use of thinner lithium and longer electrodes allows for minimum $\text{Li}:\text{SO}_2$ ratios with better cold temperature performance with a slight decrease in ambient capacity. The better cold temperature and rate performance can be primarily attributed to longer electrodes (greater surface area) and higher carbon content of the cathodes. Lower ambient capacity (low rate) is due to the low discharge (consumption) efficiency of the lithium anode.
4. The cell designs as made utilized an exterior wrap of lithium in the wind. This allowed for efficient use of cathode material but degraded from the overall utilization of the lithium.
5. The component efficiencies established during unbalanced cell testing are representative of state of the art

techniques throughout the industry and may be utilized to derive future cell designs as required.

The Mallory Battery Company recommends that future work be directed toward further evaluation of electrode construction versus performance and safety. Namely, it is suggested that an extensive effort be directed toward achieving cell designs which allow for complete consumption of lithium during discharge and low Li:SO₂ ratios. Present cell/battery designs of the BA-5598 and BA-5585 do not allow for this lithium consumption and have resulted in hazardous conditions during forced over discharge.

Methods to accomplish these goals should include cell designs with an exterior wrap of cathode and prudently matched lithium to cathode thickness. Although these cell designs could diminish maximum cell capacity the overall performance and safety would be greatly enhanced.

I. INTRODUCTION

This report documents the efforts made by the Mallory Battery Company in the design, development and manufacture of organic electrolyte battery type BA-5090 under Contract No. DAAB07-76-C-1735.

The design, development and manufacture of cell type L037S for battery type BA-5090 was completed in September, 1977. Forty cells were shipped to ECOM, while 60 cells of this type were tested by Mallory in accordance with the Technical Guidelines. The efforts were detailed in the Preliminary Design and Visualization Plan Report, copies of which were sent to ECOM.

It was observed by Mallory and ECOM that the first group of 100 cells delivered lower capacity than expected. The lower capacities were attributed to cathode inconsistency and a glass to metal seal problem. The cathode problem was resolved and ECOM conditionally approved the Preliminary Design and Visualization Plan.

Mallory fabricated 45 batteries, 25 of which were tested by Mallory in accordance with the Technical Guidelines. The remaining 20 batteries were shipped to ECOM in August, 1978.

II. CELL FABRICATION PHASE

A. Cell Construction

Cell type L037S for the battery, BA-5090, is hermetic. A glass to metal positive feed through was developed consisting of a glass seal, solid post/positive terminal and a nickel plated CRS eyelet. The flange of the eyelet around the glass seal is resistance welded to the surrounding nickel plated steel cell top.

A pressure sensitive venting mechanism is formed into the base of the nickel plated steel container. This type of mechanical vent structure allows the cell to relieve an overpressurized condition between 350-500 psig for safety considerations. A fill tube is resistance welded to the base of the cylindrical container for electrolyte filling.

Cells are constructed by winding rectangular strips of anode-separator-cathode-separator layers of the appropriate width into a cylindrical roll. This roll is then inserted into the nickel plated steel container. The anode is electrically connected to the steel container. The cathode terminal is electrically connected to the central metal post of the glass to metal seal. The top is then hermetically sealed in place by welding the periphery to the can. Electrolyte is subsequently dispensed through the fill tube in the can bottom. The fill tube is then hermetically sealed by resistance welding. Figure 27 depicts the actual cell configuration.

Incoming parts and hardware are checked by Receiving Inspection. At every fabrication stage, the operation is inspected by Quality Control. All welds are checked to be hermetic to 4×10^{-8} std. cc of He/sec. on the leak detector. The electrolyte batches are analyzed for percent SO₂ and parts per million water content. The electrodes are checked dimensionally, and each carbon cathode is weighed.

B. Cell Design

The L037S cell (for the BA-5090 battery) was conceived by Mallory prior to the date this contract was awarded. It is also the smallest size Li/SO₂ cell developed by Mallory to date, which resulted in unexpected fabrication problems.

To maximize the cell internal volume, the top shell and the glass to metal seal designs were optimized.

Unlike most conventional cells, the top shell was designed to be flat with minimum overall height. The initial design resulted in a top shell whose overall height and material thickness was too small to allow successful welding to the rim of the can. The modified design utilized greater material thickness and overall height permitting a successful weld to the can.

To maximize the available internal cell height, a thinner glass to metal seal was used initially. This glass was .050" thick instead of the standard .090". Upon welding this assembly to the top shell, the glass cracked, resulting in loss of hermeticity. Therefore the standard thicker glass eyelet was used with a terminal post of minimum length.

The initial vent mechanism resulted in unanticipated problems, caused by extreme extrapolation of existing vent design data. The cans vented at very high pressures resulting in violent vents and excessive movement. The safety vent design problems were resolved, and satisfactory cans were available at the end of November, 1976.

The cell geometry and available internal volume were the constraints on the internal components.

The cell height restricted the width of the anode and the cathode to .500". The cell internal diameter of .500" was the constraint on the length and thickness of the electrodes.

Experimental cells were made to meet the dimensional requirements using several electrode/electrolyte configurations. Various design parameters that were investigated are illustrated in Table XI.

For non high rate Li/SO₂ cells, a cathode current density of 1.0 mA/cm² is used as a standard design parameter. It can be observed from Table XI that the cathode current density of different designs ranged from .790 to 1.07 mA/cm².

Cathode thickness of less than .024" was not evaluated

due to manufacturing limitations. Cathodes of .033" thickness were also not considered since they would require reduced electrode lengths, thereby increasing the current density (mA/cm²).

As mentioned earlier, the primary purpose of this section of the contract was to develop a cell with maximum capacity performance. For this reason and due to the aforementioned fabrication problems which did not allow for extended test time, safety and Li:SO₂ ratio optimizations were secondary in design.

Scrutiny of Table XI shows that in designs 1 and 2 both the lithium and SO₂ were in excess of the delivered capacity at 75°F (ref. Section 1 Electrode Efficiency). Designs 3 and 4 which contained reduced lithium showed slightly less capacity at 75°F. However, the actual lithium content in the cell was reduced by 33% (760 mA_H to 506 mA_H) compared to design 1 but the cell capacity dropped by only 7%. It may be concluded that at 75°F the cell designs 1 and 2 were cathode limited and designs 3 and 4 were marginally anode limited.

Design 5 verified the above observations. This design contained more electrolyte than in design 1 but 5 1/2% less lithium and 6 1/4% less cathode. Capacity at 75°F was subsequently reduced by 5 1/2%.

The standard electrolyte contained 70 weight percent SO₂. To increase the electrolyte capacity and reduce the Li:SO₂ ratio with minimum design impact, electrolyte containing 80 weight percent SO₂ was evaluated. It can be seen from Table XI that cells containing 80 weight percent SO₂ in the electrolyte delivered lower capacity at -40°F than was delivered by cells containing 70 weight percent SO₂. This may be attributed to the lower conductivity of the 80 weight percent SO₂ electrolyte at -40°F than of 70 weight percent SO₂ electrolyte.

Considering all of the above observations the following design was chosen for the Cell Fabrication Phase:

Anode - 4.5"x.010"x.5"
Cathode - 4"x.024"±.002"x.5"
Electrolyte - 70% SO₂, 1.65±.05 grams

C. Cell Test Program, and Discussion of Results

One hundred cells were fabricated to meet the dimensional requirements for the battery assembly. Forty cells were delivered to ECOM, and 60 cells tested by Mallory in accordance with the Technical Guidelines. Table XII illustrates the test program. The Technical Guidelines for this section are contained in Enclosure I for ready reference.

The mechanical shock, altitude and vibration tests were conducted by Stanford Technology Corp., Glenbrook, CT, for the Mallory Battery Company. The temperature shock test was conducted by the Quality Control Department, Mallory Battery Company, North Tarrytown.

During environmental testing there was no significant change in open circuit voltage. There was no visual evidence of physical damage or leakage as a result of these tests. During vibration there were no resonant frequencies on any of the cells tested.

After the environmental testing the cells were subjected to a 30 day storage at 160°F. Open circuit voltage and cell weights were taken before and after the storage.

Fifty out of 60 cells gained an average of 3.2 mg upon storage at 160°F. This weight gain may be attributed to the weighing technique and cosmetic changes on the cells.

The remaining ten cells lost 21 mg on the average, one of which lost 97 mg. A part of this weight loss may be attributed to electrolyte leakage.

After 30 days storage at 160°F, it was also observed that 40 of the 60 cells exhibited low O.C.V. At room temperature, the O.C.V. specification is 2.915 - 3.050 volts. Before storage the O.C.V. of all cells was within the specification. The lowest O.C.V. after storage was 2.859 volts.

Voltage at the fifth second with an 18Ω load was measured before environmental testing, after environmental testing, and after the 30 day storage at 160°F. Before environmental testing, all 60 cells reached 2.0 volts within 5 seconds. After environmental testing

17 cells out of the 60 delivered under 2.0 volts with an 18Ω load, seven of these giving between 1.88 and 1.99 volts. After the 30 day storage at 160°F , the load voltage deteriorated significantly. Only 18 cells delivered more than 2.0 volts, and 18 cells gave between 1.90 and 1.99 volts.

These results indicated that the cell hermeticity and performance had deteriorated after storage at 160°F for 30 days. However, the testing was continued in accordance with the Technical Guidelines.

Ten cells were subjected to reverse discharge at 142 mA (C/3 rate). The test was carried out for 110 minutes, and no venting or explosion occurred. The maximum cell temperature during the test was 100°F .

Ten cells were discharged at a high rate (C/2 - 213 mA). No venting or explosion occurred. The maximum cell temperature during test was 114°F . The cells reached 105°F - 110°F in 40 to 70 minutes, but then started to cool down. The cells ran for an average of 30 minutes to 2.0 volts cutoff, delivering 106 MAH capacity.

Ten cells were charged at 85 mA (C/5 rate) for a total of 70 minutes. No venting or explosion occurred during the test. The temperature increased to a maximum of 105°F . The cell voltages during the test ranged from 3.95 to 3.63 volts.

It should be noted that during both of the above reverse discharge tests the cells were to be discharged into voltage reversal for twice their rated capacity. That is, 6 hours at the C/3 rate and 4 hours at the C/2 rate. Charging was to be performed for 5 hours at the C/5 rate. However, in all of the safety tests the required discharge time was not carried out due to various equipment malfunctions. These problems were corrected prior to the Battery Fabrication Phase. Any mention therefore, to safety results should be tempered with these facts. Typical observations are illustrated in Figures 28, 29 and 30.

Twenty-nine cells were discharged with a 155Ω load at 70° , 130° and -20°F (ten cells each at 130° and -20°F , and nine cells at 70°F). The results are indicated in Table XIII. The cells delivered an average of 343,

272 and 181 mA_H at 70°, 130° and -20°F respectively. Three of the ten cells delivered less than 2 hours to 2.0 volts when discharged at -20°F. The average capacity delivered at 70°F is 19% less than the estimated capacity (425 mA_H), and the capacity delivered at -20°F was 16% less than the estimated capacity (215 mA_H).

It may thus be concluded that the capacity retention of these cells is not satisfactory after 30 day storage at 160°F. To verify this, a few cells which had not undergone high temperature storage were discharged at 70° and -20°F with 25, 75 and 250Ω loads.

Figures 31, 32, 33 and 34 illustrate the discharge curves with the four different loads. The 155Ω load corresponds to a 24 hour rate and the cells delivered 425 mA_H at 70°F, and 220 mA_H at -20°F.

Four additional cells (without any high temperature storage) were discharged at -40°F with 155Ω load. Two cells did not deliver 2.0 volts, while the other two ran for 10.1 and 12.6 hours. One of the failed cells was found to have a poor internal tab weld.

The above results lead us to the following conclusions relative to 30 day storage at 160°F:

- a) Ten out of 60 cells lost an average of 21 mg in weight.
- b) Cells after storage gave low O.C.V.
- c) Cells after storage gave low load voltages.
- d) Cells after storage delivered between 15 and 20% less capacity than expected.

The leakage described by item a) above was investigated and found to be caused by insufficient heat sinking of the top during top to can TIG welding. It was found that the glass seal lost hermeticity during this TIG welding operation due to the close proximity of the weld to the glass seal. This failure was not in all cells welded but varied with the fit of the top. This problem was corrected prior to the Battery Fabrication Phase by redesigning the heat sink and introducing a 100% check of hermeticity after welding.

Items b), c) and d) above were also attributable to a glass seal problem but of a different nature. Upon disassembly of failed units, the glass on the inside of the seal was found to be covered with a precipitate after storage at 160°F. The amount of precipitate was directly proportional to the time at 160°F storage. It was clearly observed that the glass was etched and this chemical attack not only deteriorated its sealing integrity but also formed a bridge between the steel eyelet and the positive feed through. This bridging resulted in slow self-discharge which accounts for the reduced capacities delivered after storage and low open circuit voltage.

The precipitate and resulting ohmic path formed on the glass after storage is identical in the L037S cell and in the larger cells, L025S and L026S. In each cell type the absolute value of capacity lost due to self-discharge across the glass is the same. However, since the L037S has approximately 1/20 the rated capacity of the larger cells this absolute capacity loss becomes significant (i.e., .05 AH \approx 11% of L037S but less than 1.0% of L026S).

The above phenomenon of deterioration of glass was not observed on cells stored at 70°F for the same storage period of 30 days.

The time when the subject cells (100) were fabricated, Mallory was also having an unexpected cathode problem. It was observed that the adherence of carbon to the aluminum screen was unsatisfactory giving rise to inconsistent and lower capacity after storage, and poor start-up. The cathode problem has since been resolved.

The Preliminary Design and Visualization Plan was conditionally approved by ECOM. The Battery Fabrication Phase was initiated using adequate cathodes. All cells were also checked for hermeticity prior to electrolyte fill.

III. BATTERY FABRICATION PHASE

A. Battery Design

Organic electrolyte battery type BA-5090 consists of three L037S in series. This battery typically exhibits an O.C.V. of 9 volts and is provided with an internal 0.25 amp slow blow fuse. Each cell in the battery is enclosed in a plastic sleeve to prevent shorts between the cells. Each cell also has washers at the vent end to ensure space for movement at the time of cell venting.

The battery assembly is illustrated in Figure 35.

B. Battery Fabrication, Tests and Discussion of Test Results

At the time when manufacturing resumed cell fabrication for the batteries, it was realized that the 4.5" long anode and 4" cathode could not easily be inserted into the cylindrical can. To insure battery reliability the electrodes were shortened by 0.25" each, and the electrolyte weight increased by 0.05 g. This cell design is illustrated as design 5 in Table XI. Cells of this type delivered 420 mA_H and 210 mA_H at 70° and -20°F respectively, without high temperature storage.

Forty-five batteries were fabricated in August, 1978. Twenty batteries were delivered to ECOM and the remaining 25 batteries were tested by Mallory in accordance with the Technical Guidelines.

1. Environmental Tests

The shock, vibration and altitude tests were conducted by Stanford Technology Corp. in Glenbrook, CT. There was no visual evidence of physical deterioration or leakage as a result of these tests and there was no significant change in O.C.V.

The temperature shock test was conducted by the Quality Control Dept., Mallory Battery Company in North Tarrytown.

It is concluded that the batteries can withstand all the environmental tests without physical damage or leakage.

2. High Temperature Storage

The 25 batteries were next subjected to 30 days storage at 160°F. After storage all the batteries exhibited satisfactory O.C.V.

3. Electrical Tests

Ten of the 25 batteries were discharged at 636Ω load in accordance with SCS 459. Five were discharged at 130°F and the remaining five at -20°F. The test results are shown in Table XIV. Typical discharge curves are illustrated in Figure 36.

It can be observed from Table XIV that battery 4 delivered only 8.4 hours to 6.0 volts when discharged at -20°F. The other four batteries delivered 19.75 hours under the same conditions. Battery 4 was therefore disassembled for failure analysis.

It was observed that one of the three cells had leaked at the glass to metal seal. This leakage was the cause of the low capacity delivered by the battery. Battery numbers 1, 2, 3 and 5 delivered an average capacity of 229 mA.H.

Batteries discharged at 130°F delivered hours ranging from 23.7 to 26.0 hours, the average life being 25 hours. This corresponds to an average capacity of 324 mA.H.

The capacities delivered by the batteries were lower than expected due to the following reasons:

- a) It has generally been observed that cells/batteries deliver approximately 10% lower capacities after storage at 160°F for one month. Thus part of capacity loss may be attributed to the high temperature storage.
- b) Cells disassembled after discharge revealed a precipitate on the glass of the positive feed through which resulted from the chemical attack on the glass during storage at 160°F for 30 days. The precipitate produces an ohmic path across the cell terminal which results in a slow self-discharge.

It may thus be concluded that with a more compatible glass to metal seal the problems of leaks and chemical attack could be eliminated. The cells/batteries would then initially deliver 420 mA_H at 70°F and 230 mA_H at -20°F without any storage. After high temperature storage for one month they should deliver 380 and 220 mA_H at 70° and -20°F respectively.

Scrutiny of Table XI along with the electrode efficiencies generated in Section 1 leads to the following conclusions relative to the tested and proposed designs.

- Designs 1 and 2 which were cathode limited with the 80% SO₂ electrolyte showed a marked decrease in performance at -40°F.
- Designs 3 and 4 were also cathode limited since they utilized an exterior cathode wrap. Their cathode surface area was then limited by the adjacent opposing lithium.
- In designs 3 and 4, 506 mA_H of lithium yielded 408 mA_H of capacity at 75°F (≈ 80% efficiency).
- Both designs 3 and 4 have desirable Li:SO₂ ratios of 1:1.04 and 1:1.19 but yielded minimal capacity.

Based on the above, design number 6 is suggested as a future alternative which would minimize the Li:SO₂ ratio and maximize capacity. This design, however, does not utilize an exterior wrap of cathode. Therefore it is still a compromise with respect to safety but it reduces the Li:SO₂ ratio considerably.

4. Safety Tests

a. Reverse Discharge

Five batteries were reverse discharged (i.e., driven into voltage reversal) by placing each battery in series with a power supply and driving it at the C/3 rate (133 mA) for twice the rated capacity. Battery temperature and

voltage were monitored throughout the test. All batteries reached the maximum temperature (98° to 105°F) after about 3.5 to 4.0 hours in the test. Typically the batteries delivered 259 mA·h to 2.0 volts. Typical voltage and temperature profiles are illustrated in Figure 37. No vent or explosion was observed in any of the cells.

It is concluded that at the C/3 rate which corresponds to a cathode current density of 5 mA/cm², the batteries did not vent or explode upon reversed discharge.

This data conflicts with the results of Section 1 where the BA-5598 and BA-5585 batteries caught fire during the same test. It should be noted that during the tests of Section 1 the C/3 rate resulted in a current density of ≈ 6 mA/cm² on the cells. Therefore, the 5 mA/cm² on the BA-5090 battery is an extremely marginal condition.

b. High Rate Discharge

Five batteries were discharged at the C/2 rate (200 mA). Temperature and voltage were recorded throughout the test. Figure 38 illustrates the typical voltage and temperature profile versus time. Again batteries were tested for twice their rated capacity (C/2 tested for 4 hours minimum).

One of the five batteries tested vented violently with indications of an explosion/fire. The 200 mA rate corresponds to a cathode current density of 7.75 mA/cm². Four of the five batteries did not vent. As mentioned earlier, at high current densities such as 7.75 mA/cm², the cells/batteries generally have not been safe upon reversed discharge (ref. Section 1).

It may be concluded that the batteries are not safe upon reverse discharge at the C/2 rate. The batteries delivered an average capacity of 217 mA·h at 200 mA to 6.0 volts.

c. Charging Test

Five batteries were charged at a C/5 rate (80 mA) for 15 hours. Temperature and voltage were recorded throughout the test. The batteries attained a maximum temperature of 106°F. Upon opening the batteries it was observed that none of the cells in the batteries had vented or exploded. Figure 39 illustrates typical battery voltage and temperature versus time.

It is concluded that charging the BA-5090 batteries at 80 mA for 15 hours resulted in no venting or explosions/fire.

IV. CONCLUSIONS AND RECOMMENDATIONS

Organic electrolyte cell type L037S was developed for battery type BA-5090. The battery consists of three L037S cells in series with an internal .25 amp fuse.

The cells and batteries as developed demonstrated the capability of successfully passing all the environmental and structural tests as outlined in the Technical Guidelines.

Initial cell tests at 70° and -20°F yielded 420 mA and 230 mA respectively. After high temperature storage the capacities dropped to 380 mA at 70°F and 220 mA at -20°F. The reasons for the drop in 70°F performance were attributed to glass seal incompatibility and unsatisfactory adherence of the carbon to the aluminum exmet in the cathode. The adherence problem of the carbon was resolved prior to cell assembly for the Battery Fabrication Phase.

Battery testing after 30 days at 160°F yielded 229 mA at -20°F and 324 mA at 130°F. The 130°F test results were again lower than expected due to the aforementioned glass seal compatibility problem resulting in slow discharge across the glass. Efforts are being made by Mallory to resolve this problem. All future cells will have this problem corrected.

Reverse discharge tests on the L037S cell and BA-5090 battery at the C/2 and C/3 rates disclosed the existence of safety hazards under such conditions. To minimize these hazards it is suggested that lithium limited cells (Li:SO₂ ratio = 1:≤1 within specified tolerances) should be made for future procurements. Consequently, a development program is recommended for this and all future organic electrolyte batteries.

No explanations or design recommendations are presently available to completely preclude the hazards attendant to cell charging.

TABLE I

VENT TEST SUMMARY
(5 Cells per Test Parameter)

<u>Test</u>	<u>Cell Type</u>	<u>Vent Temperature</u>	<u>Average Deflection</u>	<u>Observations</u>
Charge 2.0 amperes	Control	167°F	.030"	Normal vent
	50% vent height	260°F	-----	Cells exploded
	75% vent height	182°F	.070"	Normal vent
Reverse Discharge 3.3 amperes	Control	265°F	.058"	Normal vent
	50% vent height	280°F	-----	Cells exploded
	75% vent height	275°F	.091"	Vent with high deflection
Hydraulic Pressure	Control	Vent Pressure 400 psig	.040"	Normal vent
	50% vent height	1,000+ psig	.100"	Did not vent
	75% vent height	650 psig	.100"	Excessive vent
Short Circuit Test ($<.045\Omega$)	Control	Vent Temperature 154°F	.040"	Normal vent
	50% vent height	248°F	.089"	Vent with bulge
	75% vent height	189°F	.098"	Vent with bulge
Incineration ($\geq 1,000^\circ\text{F}$)	Control	-----	.065"	Normal vent
	50% vent height	-----	-----	Cells exploded
	75% vent height	-----	.124"	Bulged vent

TABLE II

COMPONENT VOLUMETRIC EFFICIENCY

<u>Cell Component</u>	<u>Density g/cc</u>	<u>AH/g Theoretical</u>	<u>Assumed Efficiency</u>	<u>AH/g Actual</u>	<u>AH/cc Actual</u>	<u>cc/AH Actual</u>	<u>Cell Volume Required</u>	
Anode Lithium	.531	3.86	90%	3.47	1.84	.543	12.7%	
Cathode Carbon	1.95	----	---	2.0	3.90	.256	6.0%	
Teflon	2.15	----	---	40.0	86.0	.012	.3%	
Exmet	2.7	----	---	3.8	10.26	.097	2.3%	
Tab	2.7	----	---	53.7	19.88	.050	1.2%	
Separator Celgard	.9	----	---	13.0	11.7	.085	2.0%	
Insulators Polypropylene	.9	----	---	53.5	48.16	.021	.5%	
Electrolyte 70% SO ₂ at 180°F	1.08	.296	97%	.287	.310	3.22	75.2%	
Overall Volumetric Performance							4.28	100.2%

TABLE III

UNBALANCED CELL DESIGNS LO25

Variable	Lithium (inches)	Cathode (inches)	Wt. (g)	Cathode			Electrolyte Wt. (g)
				Carbon (%)	Graphite (%)	Teflon (%)	
#5 Lithium							
A) Low	28x1.35x.008	26x1.35x.033	8.0	95	0	5	35.5
B) Control	28x1.35x.012	26x1.35x.033	8.0	95	0	5	35.5
C) High	28x1.35x.015	26x1.35x.033	8.0	85	0	5	35.5
#6 Electrolyte							
A) Low	28x1.35x.012	26x1.35x.033	8.0	95	0	5	25.5
B) Control	28x1.35x.012	26x1.35x.033	8.0	95	0	5	35.5
C) High	28x1.35x.010	26x1.35x.033	8.0	95	0	5	40.5
#4 Cathode Mix							
A) + Graphite	28x1.35x.012	26x1.35x.033	8.0	85	5	10	35.5
B) Low Carbon	28x1.35x.012	26x1.35x.033	8.0	90	0	10	35.5
C) Control	28x1.35x.012	26x1.35x.033	8.0	95	0	5	35.5
#3 Cathode							
A) Low	28x1.35x.012	26x1.35x.023	6.5	95	0	5	35.5
B) Control	28x1.35x.012	26x1.35x.033	8.0	95	0	5	35.5
C) High	28x1.35x.012	26x1.35x.042	9.6	95	0	5	35.5
#7 Cathode Alt #1							
A) Low	22x1.35x.015	21x1.35x.033	6.5	95	0	5	35.5
B) Control	28x1.35x.012	26x1.35x.033	8.0	95	0	5	35.5
C) High	34x1.35x.010	32x1.35x.033	9.6	95	0	5	35.5

TABLE IV
CAPACITY TEST SUMMARY

<u>Group</u>	<u>Load</u>	<u>Test Temperature</u>	<u>Hours To 2.0V</u>
#4 Cathode Mix			
A) + Graphite	7 ohm	Ambient	25.1, 26.0
	7 ohm	-40°F	12.3, 12.4
B) Low Carbon	7 ohm	Ambient	27.2, 25.1
	7 ohm	-40°F	8.6, 12.6
C) Control	7 ohm	Ambient	25.6
	7 ohm	-40°F	8.3, 11.6
#3 Cathode			
A) Low	7 ohm	Ambient	23.2, 23.6
	7 ohm	-40°F	8.0, 8.3
B) Control	7 ohm	Ambient	24.4, 23.2
	7 ohm	-40°F	12.0, 14.1
C) High	7 ohm	Ambient	25.4, 25.5
	7 ohm	-40°F	14.8, 15.0
#5 Lithium			
A) Low	7 ohm	Ambient	19.0, 20.0
	7 ohm	-40°F	12.1, 14.1
B) Control	7 ohm	Ambient	25.1, 24.0
	7 ohm	-40°F	13.6, 13.2
C) High	7 ohm	Ambient	25.9, 25.9
	7 ohm	-40°F	9.6
#6 Electrolyte			
A) Low	7 ohm	Ambient	18.5, 18.8
	7 ohm	-40°F	5.2
B) Control	7 ohm	Ambient	25.8, 25.3
	7 ohm	-40°F	13.3, 9.6
C) High	7 ohm	Ambient	22.8, 24.6
	7 ohm	-40°F	12.4
#7 Cathode Alt #1			
A) Low	7 ohm	Ambient	20.7, 18.8
	7 ohm	-40°F	9.7
B) Control	7 ohm	Ambient	24.3, 24.2
	7 ohm	-40°F	11.1, 14.4
C) High	7 ohm	Ambient	25.7, 25.9
	7 ohm	-40°F	17.2, 17.6

TABLE V
CELL CAPACITY TESTING
LO25S Unbalanced Cells

	<u>Ambient</u>	<u>-40°F</u>	<u>Current Density</u>
Lithium Lo 5A Hi 5C	7.8 AH 10.36 AH	5.24 AH	.88 mA/cm ²
Electrolyte Lo 6A Hi 6C	7.46 AH 9.48 AH	2.08 AH 4.96 AH	.88 mA/cm ² .88 mA/cm ²
Carbon Lo 7A Alt #1 Hi 7C	7.9 AH 10.32 AH	3.88 AH 6.96 AH	1.09 mA/cm ² .73 mA/cm ²
STD 5B, 6B, 7B	9.9 AH	4.99 AH	.88 mA/cm ²
Cathode Mix + Group 4A Lo C 4B	10.2 AH 10.46 AH	4.94 AH 4.24 AH	.88 mA/cm ² .88 mA/cm ²
Carbon Lo 3A Hi 3C	9.36 AH 10.18 AH	3.26 AH 5.96 AH	.88 mA/cm ² .88 mA/cm ²

TABLE VI
PRELIMINARY CELL FABRICATION
CELL DESIGNS

BA-5598 L025S Cells

Anode	1.35"x.010"x32.5"	
Cathode	1.35"x.033"x31"	Surface area = 540 cm ²
Separator	1.625"x.001"x70"	Celgard
Electrolyte	70% SO ₂	36.5 g
Li:SO ₂	1.38:1	

BA-5585 L030S Cells

Anode	1.625"x.010"x18.75"	
Cathode	1.625"x.033"x17.625"	Surface area = 370 cm ²
Separator	1.875"x.001"x70"	Celgard
Electrolyte	70% SO ₂	24.7 g
Li:SO ₂	1.42:1	

TABLE VII

CELL FABRICATION PHASE
CAPACITY TEST SUMMARY
LO25S CELLS (BA-5598)

<u>Cell Number</u>	<u>Discharge Temp.</u>	<u>Discharge Load</u>	<u>OCV</u>	<u>Hours To 2.0V</u>
2	70°F	7Ω	3.007	25.22
3	70°F	7Ω	3.007	25.00
4	70°F	7Ω	2.996	24.69
5	70°F	7Ω	3.003	24.75
7	70°F	7Ω	3.005	22.19
8	70°F	7Ω	3.009	24.95
9	70°F	7Ω	3.006	25.24
10	70°F	7Ω	3.016	24.65
11	70°F	7Ω	2.997	24.64
14	70°F	7Ω	3.013	25.25
Mean = 24.65		Std. Dev. = .90		
15	160°F	7.45Ω	3.000	25.60
16	160°F	7.45Ω	3.001	25.70
18	160°F	7.45Ω	3.004	25.25
20	160°F	7.45Ω	3.015	27.50
21	160°F	7.45Ω	3.004	23.25
22	160°F	7.45Ω	3.004	Bad Connection
24	160°F	7.45Ω	3.012	26.60
27	160°F	7.45Ω	2.999	27.18
28	160°F	7.45Ω	3.005	26.00
29	160°F	7.45Ω	3.000	22.68
Mean = 25.52		Std. Dev. = 1.64		
32	-40°F	7.45Ω	3.020	17.85
33	-40°F	7.45Ω	3.009	16.75
35	-40°F	7.45Ω	3.004	15.90
36	-40°F	7.45Ω	3.016	17.75
38	-40°F	7.45Ω	3.006	18.75
39	-40°F	7.45Ω	3.010	17.25
40	-40°F	7.45Ω	3.011	15.53
41	-40°F	7.45Ω	3.001	15.66
42	-40°F	7.45Ω	3.022	16.20
44	-40°F	7.45Ω	3.001	15.00
Mean = 16.66		Std. Dev. = 1.21		

TABLE VIII

CELL FABRICATION PHASE
CAPACITY TEST SUMMARY
LO30S CELLS (BA-5585)

<u>Cell Number</u>	<u>Discharge Temp.</u>	<u>Discharge Load</u>	<u>OCV</u>	<u>Hours To 2.0V</u>
1	70°F	9.6Ω	3.006	23.48
2	70°F	9.6Ω	3.008	23.20
3	70°F	9.6Ω	2.992	23.96
4	70°F	9.6Ω	3.002	23.62
6	70°F	9.6Ω	3.003	23.45
8	70°F	9.6Ω	3.007	23.40
9	70°F	9.6Ω	3.000	23.40
10	70°F	9.6Ω	3.008	23.47
11	70°F	9.6Ω	2.998	23.63
13	70°F	9.6Ω	3.005	23.60
	Mean = 23.52		Std. Dev. = .20	
14	160°F	9.9Ω	2.991	23.75
15	160°F	9.9Ω	3.000	24.75
16	160°F	9.9Ω	2.998	24.15
17	160°F	9.9Ω	2.993	23.75
18	160°F	9.9Ω	3.001	23.60
19	160°F	9.9Ω	2.993	24.28
20	160°F	9.9Ω	2.987	23.70
21	160°F	9.9Ω	3.002	24.35
23	160°F	9.9Ω	3.002	24.35
24	160°F	9.9Ω	2.990	23.97
	Mean = 24.065		Std. Dev. = .37	
25	-40°F	9.9Ω	3.002	15.25
26	-40°F	9.9Ω	3.003	15.00
27	-40°F	9.9Ω	3.005	15.20
29	-40°F	9.9Ω	3.004	15.00
30	-40°F	9.9Ω	3.008	14.50
31	-40°F	9.9Ω	3.010	15.08
33	-40°F	9.9Ω	3.007	15.13
34	-40°F	9.9Ω	3.013	15.20
36	-40°F	9.9Ω	3.014	15.55
37	-40°F	9.9Ω	2.999	15.25
	Mean = 15.12		Std. Dev. = .27	

TABLE IX
BATTERY FABRICATION PHASE
CELL DESIGNS

BA-5598 L025S Cells

Type A

Anode	1.35"x.010"x32.5"	
Cathode	1.35"x.033"x31"	Surface area = 540 cm ²
Separator	1.625"x.001"x70"	Celgard
Electrolyte	70% SO ₂	36.5 g
Li:SO ₂	1.38:1	

Type B

Anode	1.35"x.008"x32.5"	
Cathode	1.35"x.033"x31"	Surface area = 540 cm ²
Separator	1.625"x.001"x70"	Celgard
Electrolyte	70% SO ₂	38.0 g
Li:SO ₂	1.06:1	

BA-5585 L030S Cells

Type A

Anode	1.625"x.010"x18.2"	
Cathode	1.625"x.033"x17.3"	Surface area = 363 cm ²
Separator	1.875"x.001"x40"	Celgard
Electrolyte	70% SO ₂	24.6 g
Li:SO ₂	1.38:1	

Type B

Anode	1.625"x.008"x18.2"	
Cathode	1.625"x.033"x17.3"	Surface area = 363 cm ²
Separator	1.875"x.001"x40"	Celgard
Electrolyte	70% SO ₂	25.6 g
Li:SO ₂	1.14:1	

TABLE X
BATTERY FABRICATION PHASE
DISCHARGE TEST SUMMARY
(Pulse Regime)

<u>Battery S/N</u>	<u>Lithium Thickness</u>	<u>Temp. (°F)</u>	<u>Req'd. Cap. (hrs)</u>	<u>Actual (hrs)</u>	<u>Start-Up Cycles</u>
5598 - 116	.010"	130	45	73	1
5598 - 117	.010"	130	45	73	1
5598 - 146	.008"	130	45	59	1
5598 - 147	.008"	130	45	63.3	1
5598 - 114	.010"	-20	30	46.7	1
5598 - 115	.010"	-20	30	44.3	1
5598 - 144	.008"	-20	30	52.7	1
5598 - 145	.008"	-20	30	48.3	1
5585 - 114	.010"	130	19	42.5	8
5585 - 115	.010"	130	19	41.7	5
5585 - 144	.008"	130	19	42.0	7
5585 - 145	.008"	130	19	39.8	21
5585 - 112	.010"	-20	10	20.2	44
5585 - 113	.010"	-20	10	24.3	40
5585 - 142	.008"	-20	10	25.0	39
5585 - 143	.008"	-20	10	24.8	49

TABLE XI

DESIGN PARAMETERS AND CELL PERFORMANCE

Design No.	Anode		Cathode Dimensions (inches)	Electrolyte		Capacity (mAh)		Limiting Electrode Current Density (mA/cm ²)	Li:SO ₂ Ratio	
	Dimensions (inches)	mAh		% SO ₂	g	75°F	-40°F			
1	4.5x.010x.5	760	4x.024x.5	70	1.65	481	444	211	.8	1.58:1
2	4.5x.010x.5	760	4x.024x.5	80	1.65	550	440	167	.8	1.38:1
3	3x.010x.5	506	4x.028x.5	70	1.8	525	408	193	1.07	.96:1
4	3x.010x.5	506	4x.028x.5	80	1.8	600	367	146	1.07	.84:1
5	4.25x.010x.5	717	3.75x.024x.5	70	1.69	493	420	210	.85	1.45:1
6	4.5x.008x.5	608	4x.024x.5	70	1.73	506	440	211	.8	1.2:1

Expected

TABLE XII
CELL TEST PROGRAM

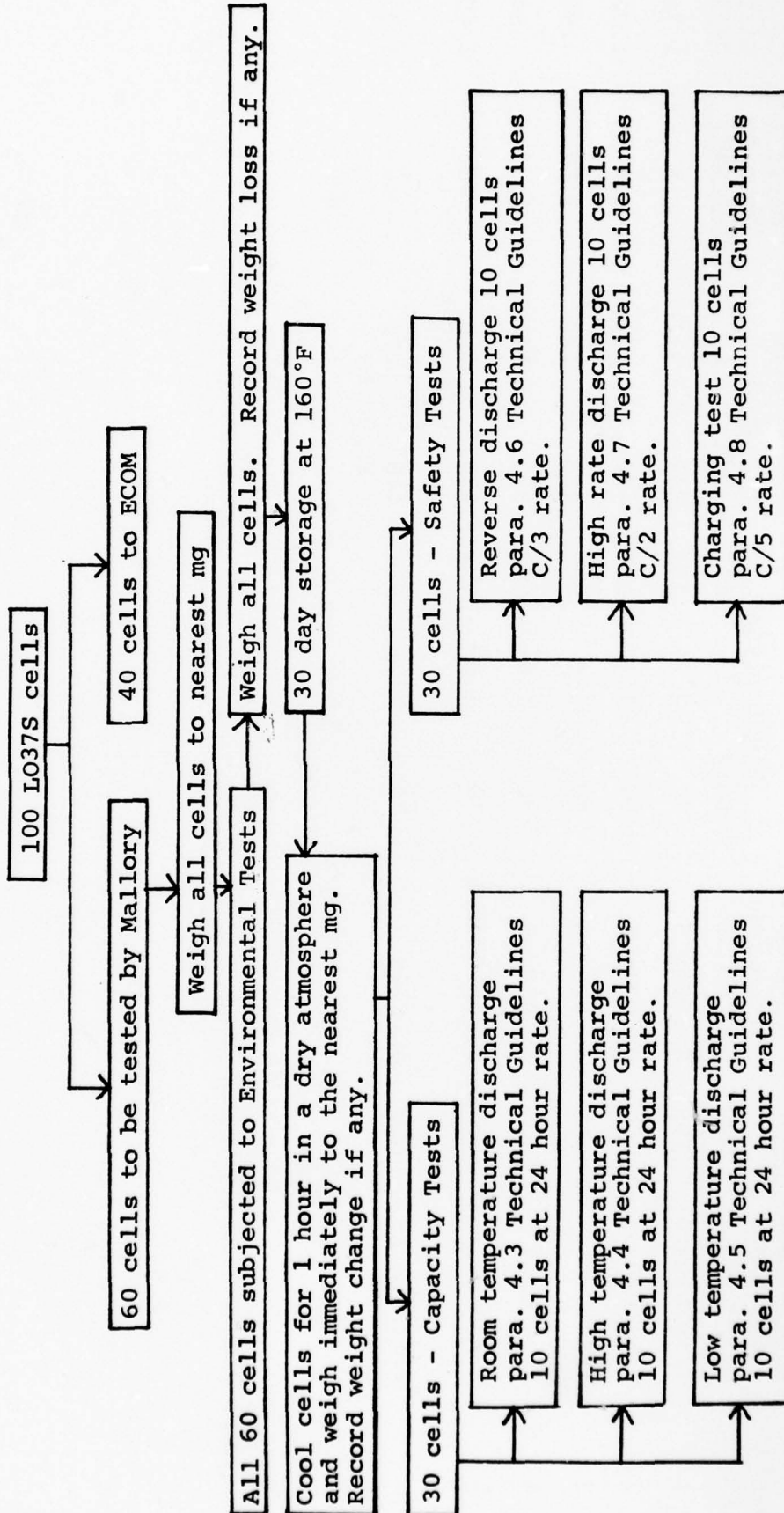

Notes: 24 hour rate = 155Ω
Cell capacity at R.T. = .425 AH = C

TABLE XII
CELL TEST PROGRAM
(Continued)

Sixty cells subjected to the following Environmental Tests:

- a) Weigh and record weight of each cell to the nearest mg.
- b) Temperature Shock - MIL-STD-810B, Method 503 for five cycles (omit step 9).
- c) Shock - MIL-STD-810B, Method 516, Procedure I, Curve 516-2, for ground equipment. Do not operate during or after test.
- d) Vibration - MIL-STD-810B, Method 514, Equipment Category (h), Procedure X, Curves AA and AQ, Time Schedule IV. Do not operate during or after test.
- e) Altitude - MIL-STD-810B, Method 500, Procedure II, omit step 5. In step 6, return chamber to standard ambient conditions.
- f) Reweigh all cells and determine the weight loss if any.

TABLE XIII

CELL CAPACITY TESTS*

70°F		-20°F		130°F	
O.C.V.	Hours To 2.0V	O.C.V.	Hours To 2.0V	O.C.V.	Hours To 2.0V
	Capacity mAH		Capacity mAH		Capacity mAH
2.993	21.0	2.889	(4.1)** 10.0	2.894	13.8
2.890	16.8	2.910	(4.1)** 10.0	2.923	16.5
2.902	19.1	2.902	1.1	2.896	15.5
2.983	21.0	2.910	10.1	2.943	15.8
2.923	19.0	2.898	10.5	2.893	13.3
2.881	17.3	2.985	14.1	2.904	14.0
2.905	17.8	2.894	(2.2)** 11.4	2.952	19.8
2.894	20.2	2.909	1.6	2.902	14.8
2.935	22.0	2.903	1.7	2.906	16.6
-----	-----	2.954	12.5	2.915	16.8
	Avg. - <u>343</u> mAH		Avg. - <u>181</u> mAH		Avg. - <u>273</u> mAH

*After 30 days storage at 160°F, 155Ω load

**Time to 2.0V, but voltage came back up

TABLE XIV
BATTERY CAPACITY TESTS*

<u>Battery No.</u>	<u>O.C.V.</u>	<u>Test Temp. °F</u>	<u>Start-up Seconds</u>	<u>Hours To 6.0V</u>	<u>Estimated Capacity mA_H</u>
1	8.82	-20	Instantaneous	18.6	216
2	8.81	-20	Instantaneous	20.4	237
3	8.80	-20	12.0	19.2	223
4	8.81	-20	7.25	8.4	---
5	8.82	-20	33.9	20.8	241
6	8.83	130	Instantaneous	23.7	308
7	8.82	130	Instantaneous	25.7	334
8	8.83	130	Instantaneous	26.0	338
9	8.82	130	Instantaneous	24.1	313
10	8.79	130	Instantaneous	25.2	328

*After 30 days storage at 160°F, 636Ω load

BASE OF CAN WITH CONVOLUTION VENT

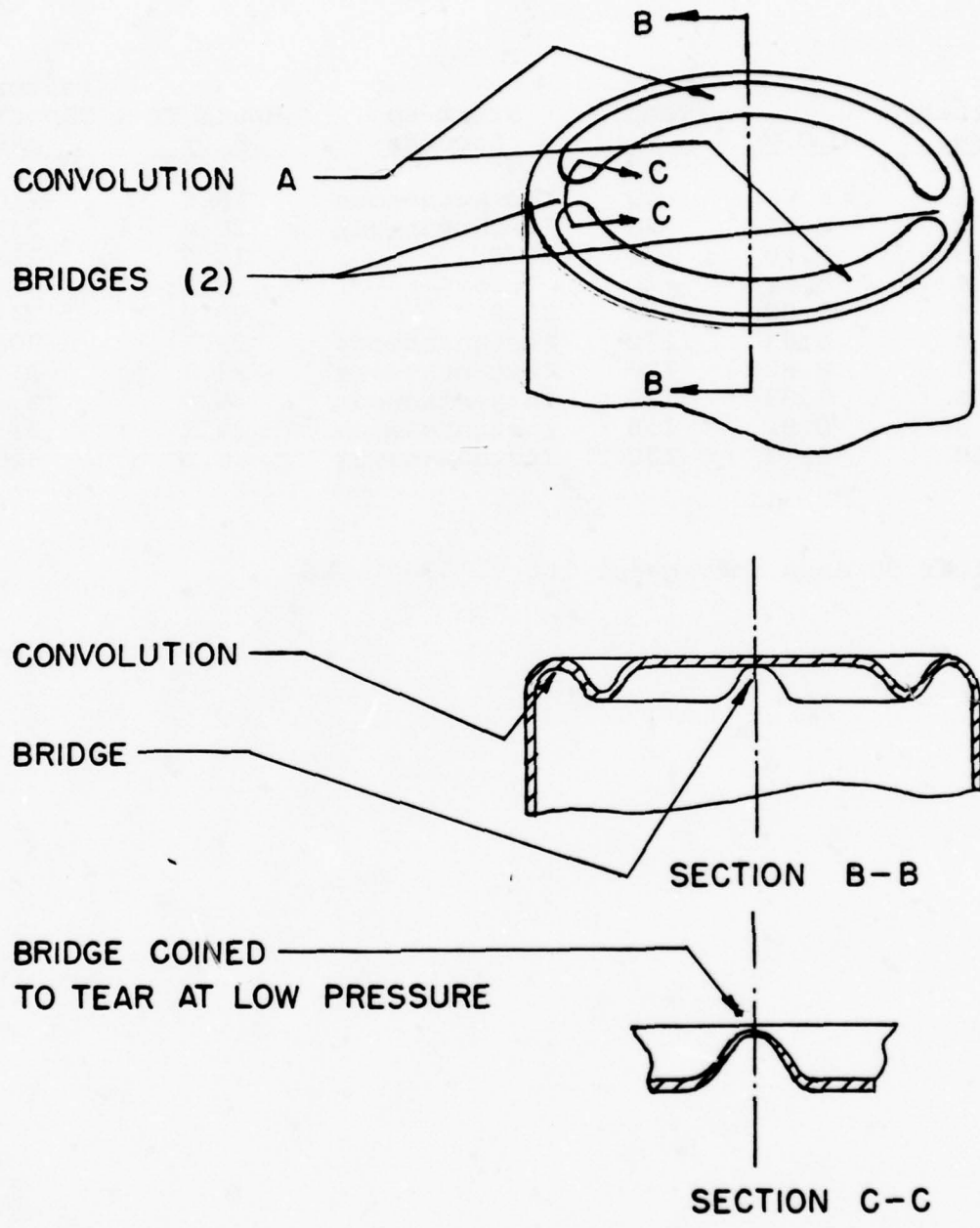

FIG. 1

- Subject matter appearing on this page constitutes matter exempted from disclosure under the F.O.I.A., 5 U.S.C. 552(b) (4), and precluded from disclosure under 18 U.S.C. 1905.
- Use or Disclosure of proposed data is subject to the restriction on the title page of this proposal.
- LIMITED RIGHTS LEGEND: Contact No. _____; Contactor: P. R. Mallory & Co. Inc.; Explanation of Limited Rights Data Identification Method Used: The technical data subject to this restriction is circled.

TYPICAL TEMPERATURE PROFILES OF CRITICAL UNBALANCED CELL GROUPS (force discharged)

TEST TEMP. — 75°F.
 X HIGH LITHIUM (.015")
 ● CONTROL (.012")
 + LOW LITHIUM (.008")
 --- 3.3 AMPERE DISCHARGE
 — 5.0 AMPERE DISCHARGE
 TEST VEHICLE — LO25\$ CELLS

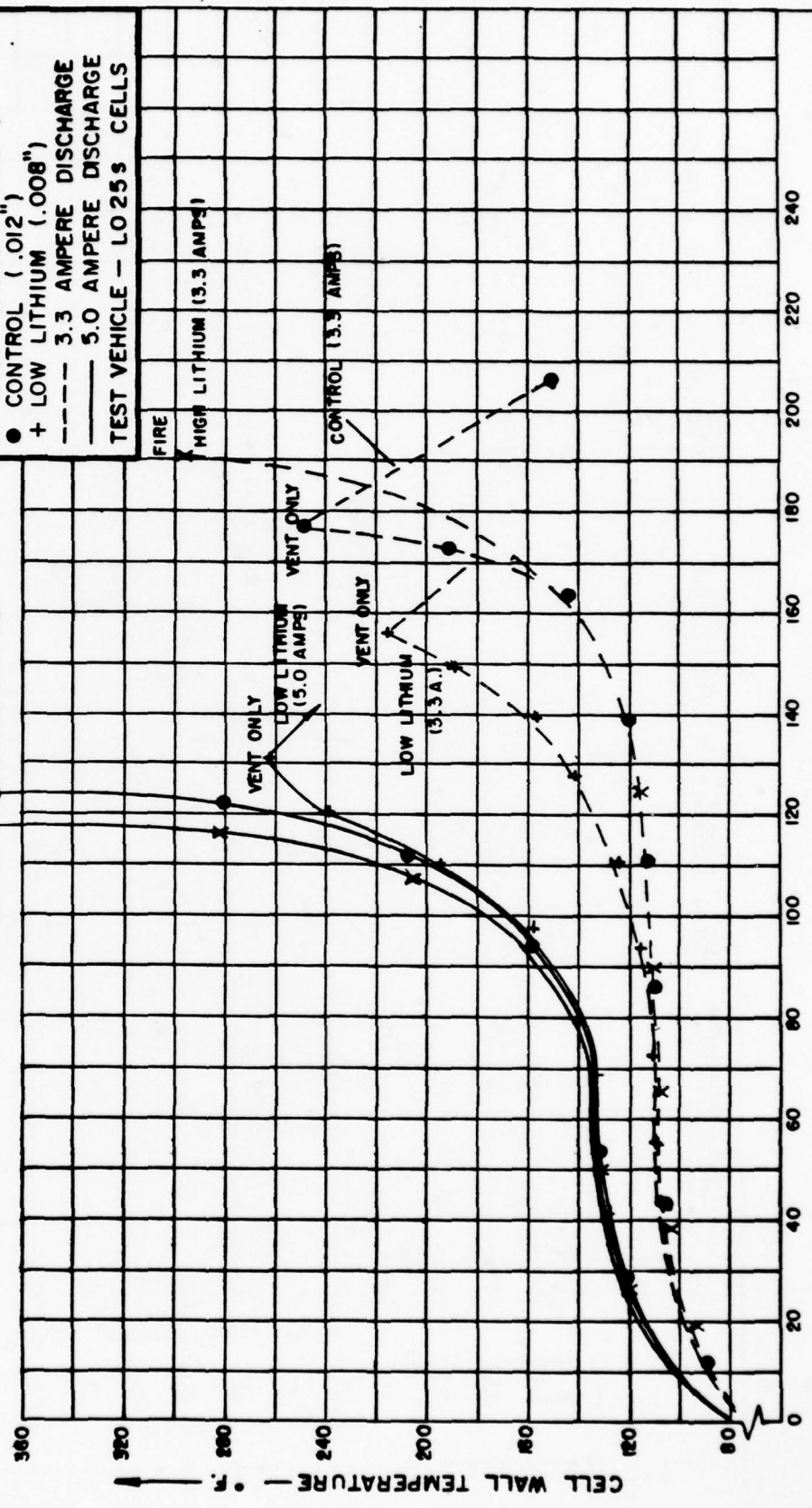

FIG. 2

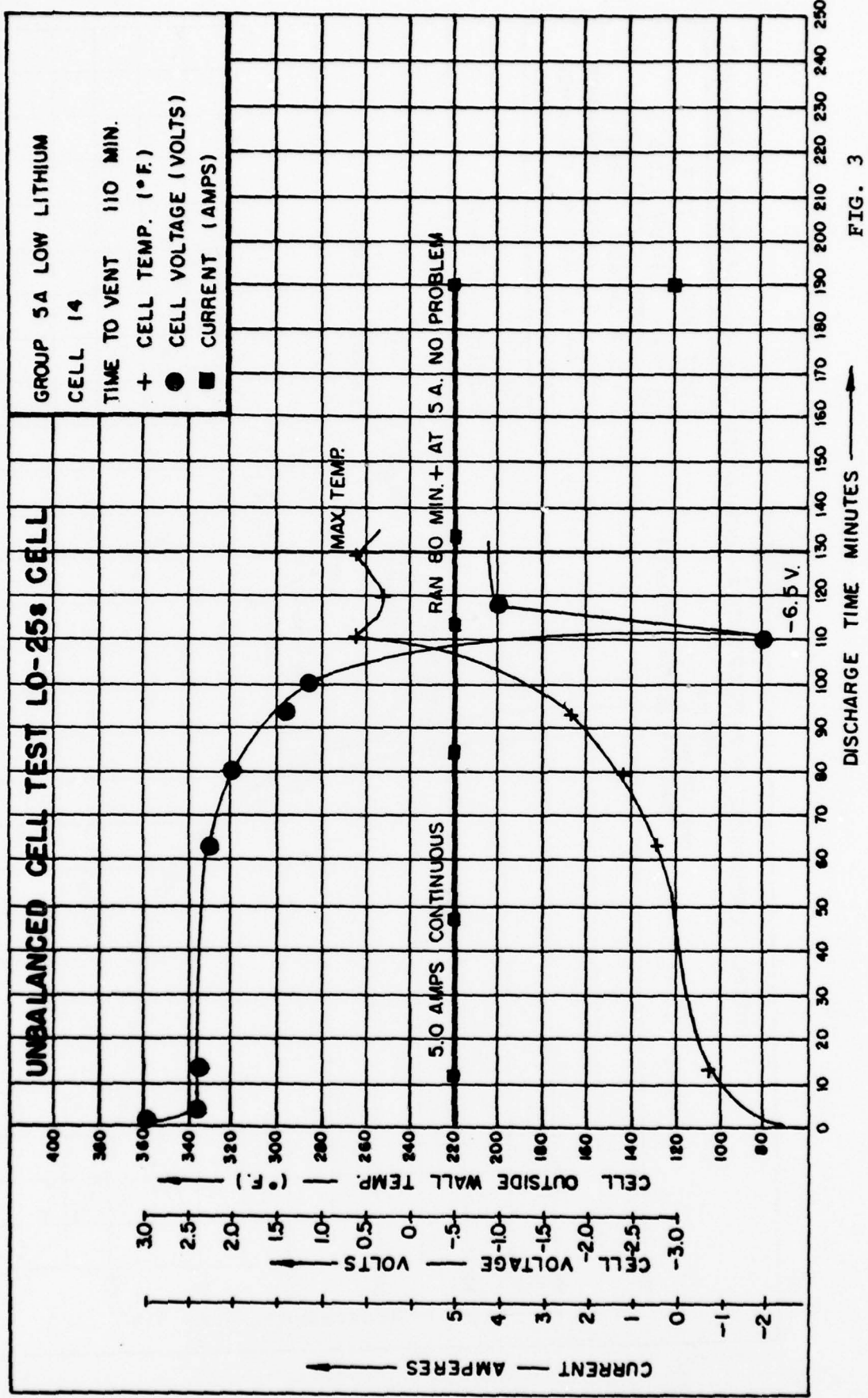

FIG. 3

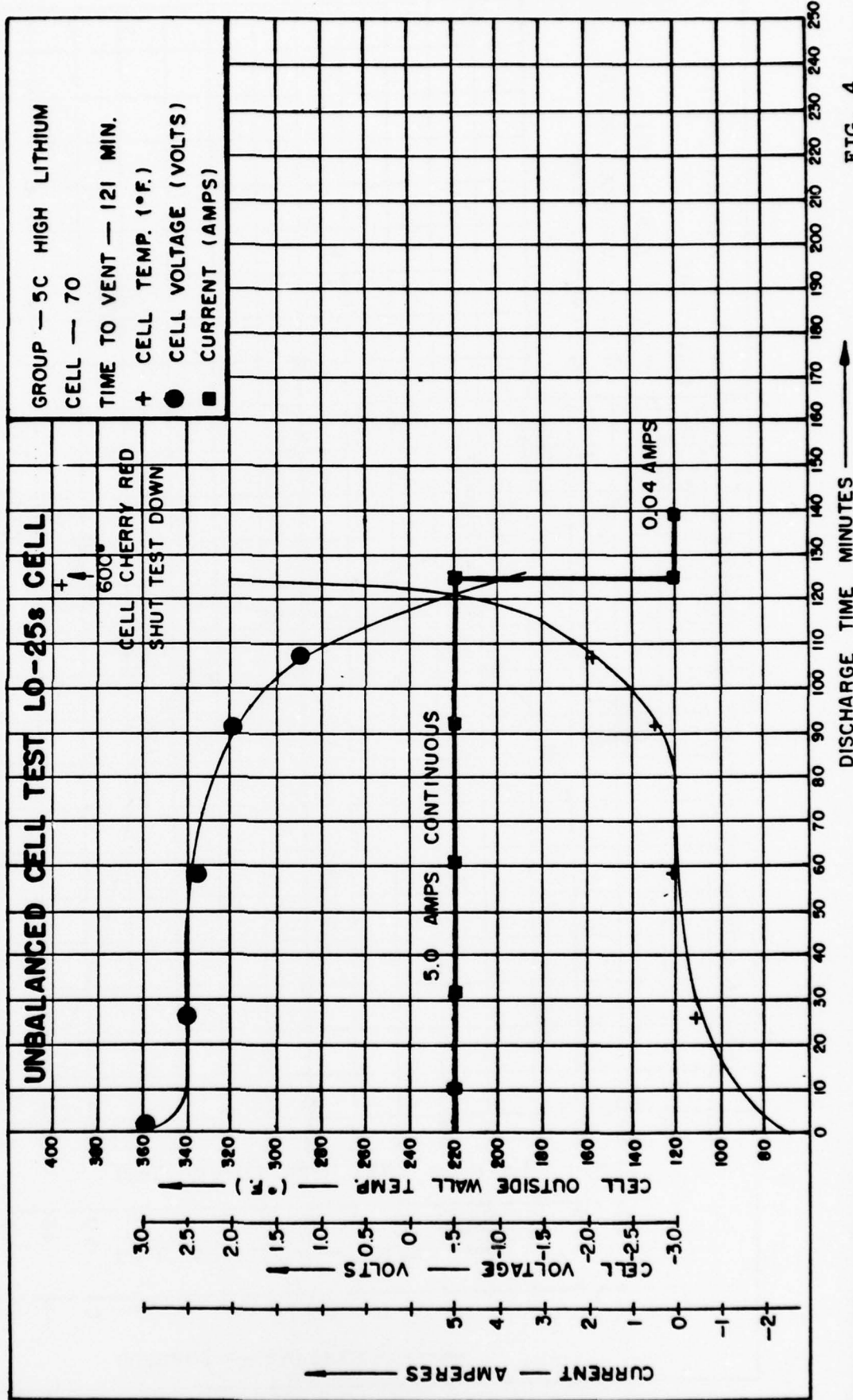

FIG. 4

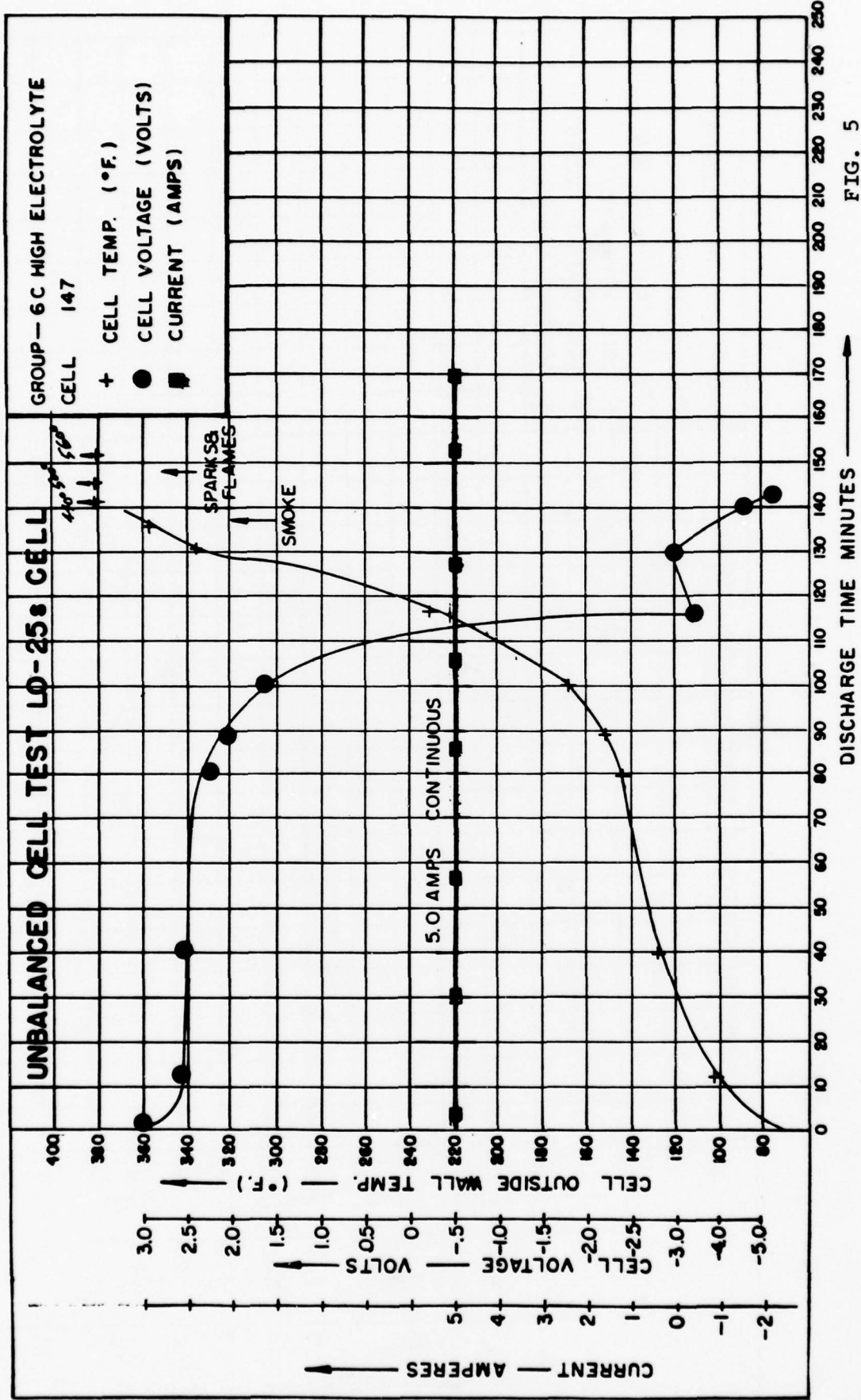

FIG. 5

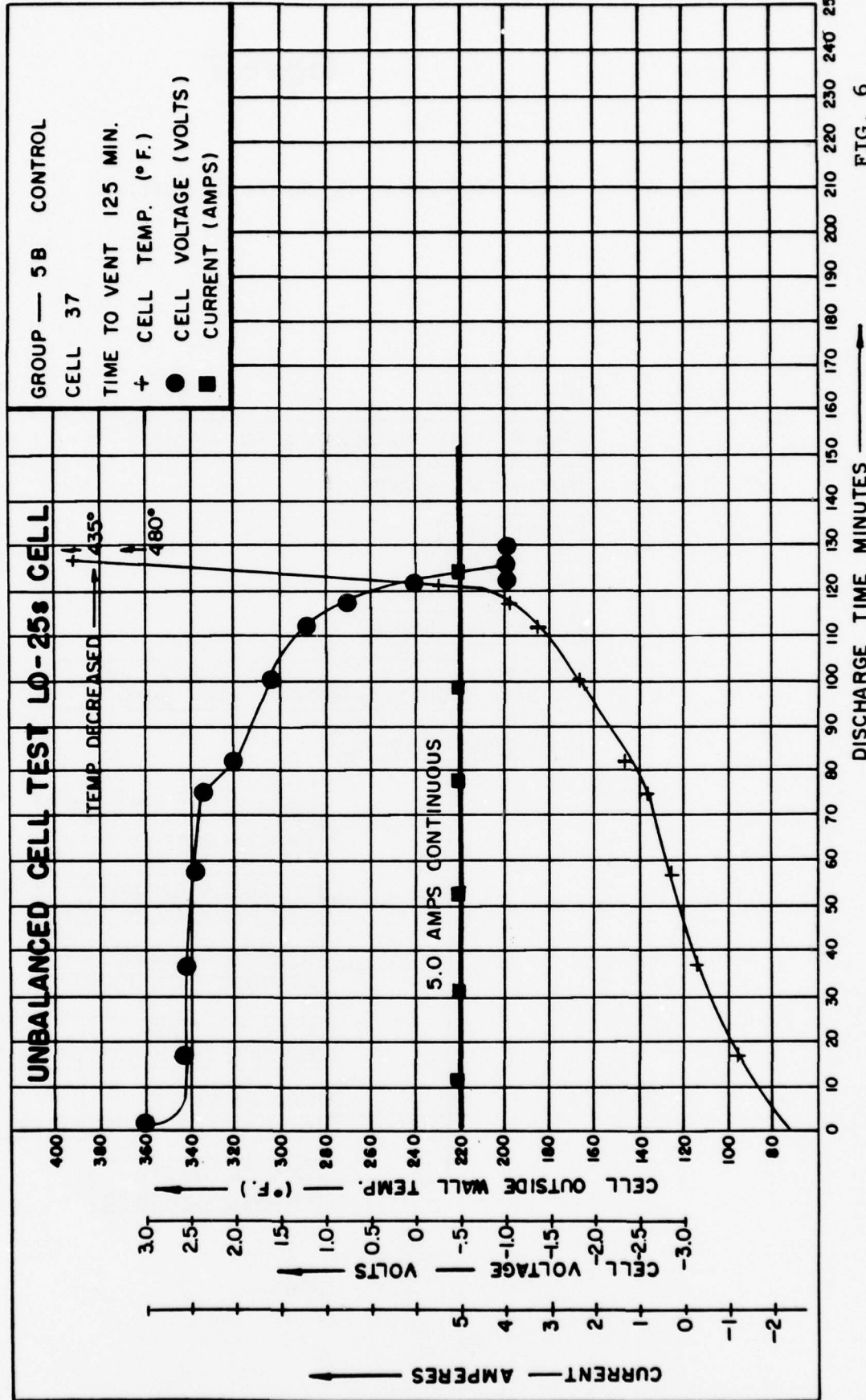
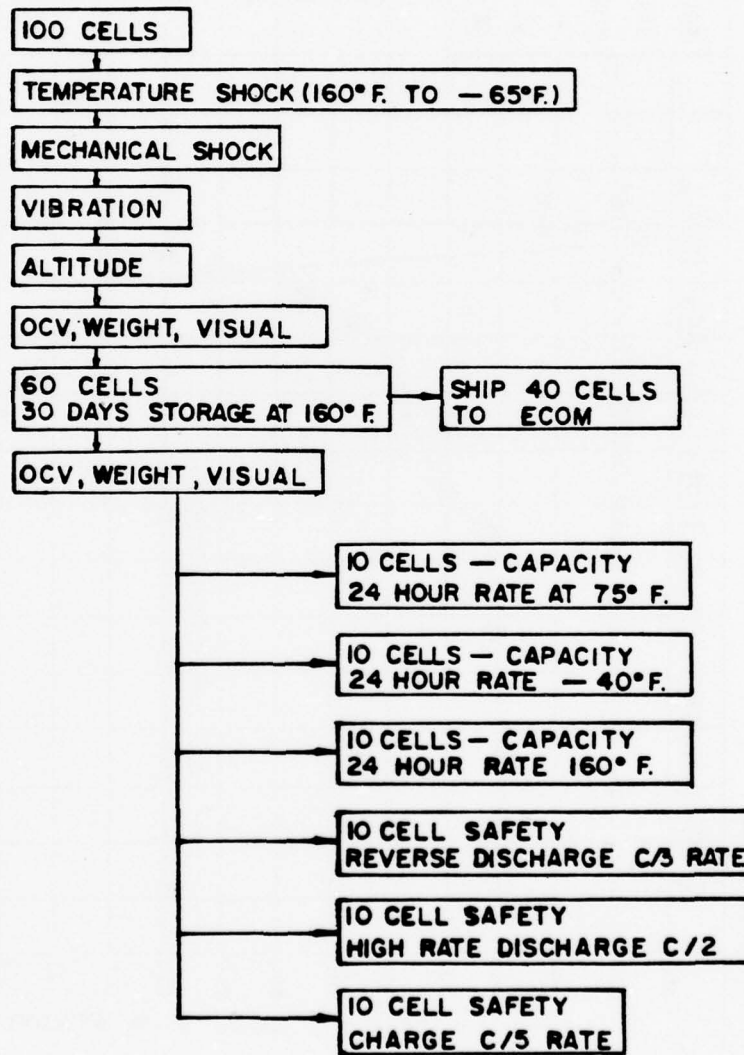

FIG. 6

Figure 7

PRELIMINARY CELL FABRICATION PHASE TEST OUTLINE



REVISIONS	
ISSUE	DESCRIPTION

Use or disclosure of proposal data is subject to the restriction on the title page of this proposal.

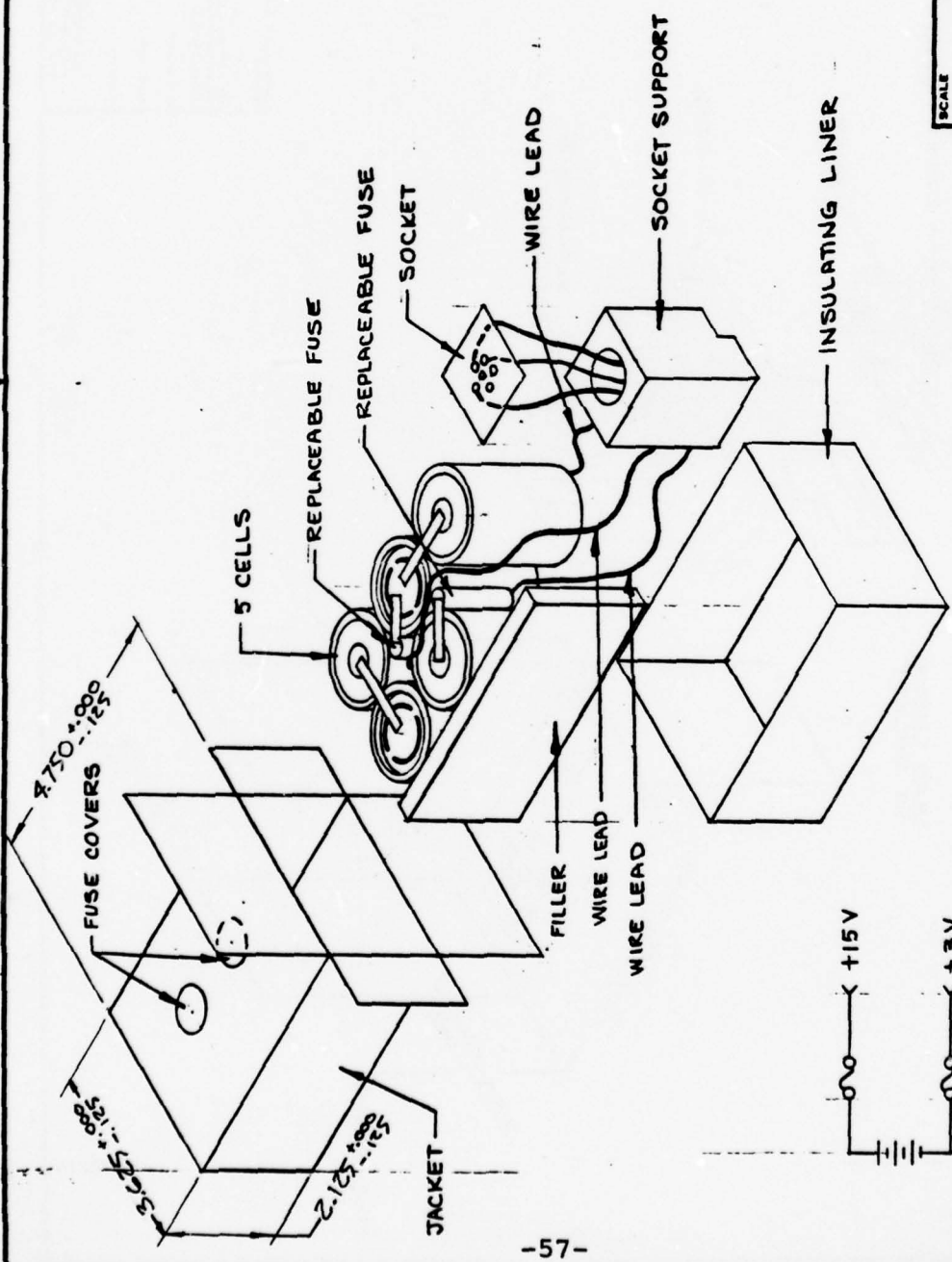

SCALE	MALLORY BATTERY COMPANY
DO NOT SCALE	© Mallory & Co. Inc. 1942
TOLERANCES	ALL DIMENSIONS UNLESS OTHERWISE SPECIFIED
DECIMALS	TITLE ASSEMBLY BA5598/U, SC5 459/12
FRACTIONS	DESIGNER DATE 6/1-35 SHEET 10F SHEETS
ANGLES	DRAWN BY K. DORMAN
	CHECKED BY [Signature]
	APPROVED BY [Signature]
	B-
THESE DRAWINGS AND SPECIFICATIONS ARE THE PROPERTY OF THE MALLORY BATTERY COMPANY, A DIVISION OF P. MALLORY & CO. INC. AND SHALL NOT BE REPRODUCED, OR COPIED, OR USED AS THE BASIS FOR THE MANUFACTURE OR SALES OF APPARATUS WITHOUT PERMISSION.	

SCHEMATIC WIRING DIAGRAM

FIG. 8

REVISIONS	DESCRIPTION	MEMO
ISSUE		

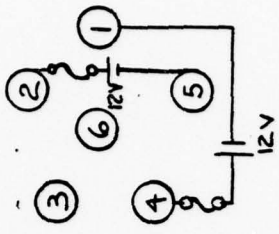
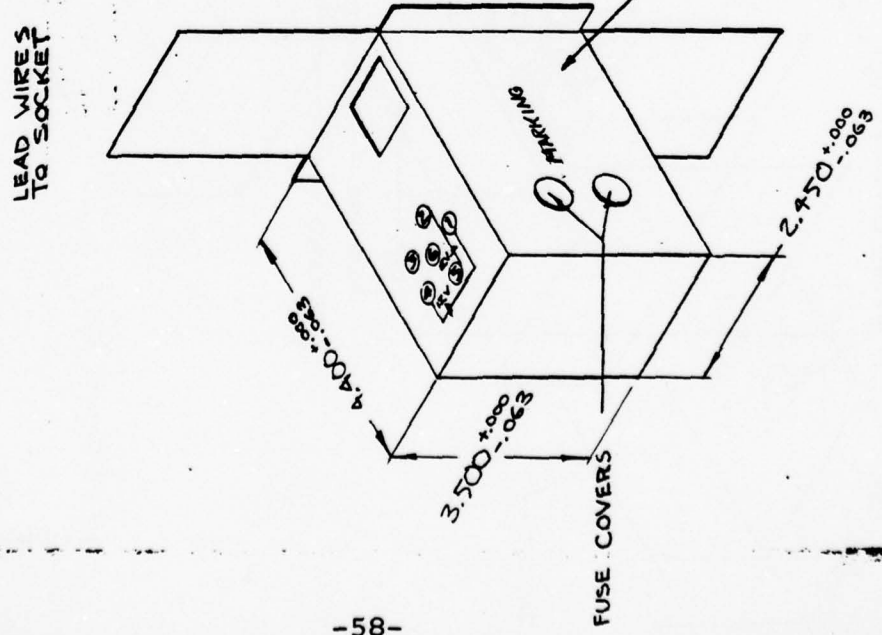
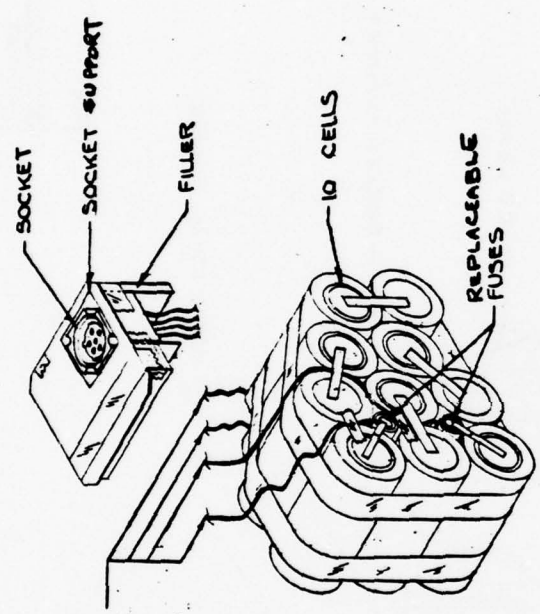

SCHEMATIC

"Use or disclosure of proposal data is subject to the restriction on the title page of this proposal."

SCALE	MALLORY BATTERY COMPANY
DO NOT SCALE	TITLE BATTERY ASSEMBLY BAST054, SCS 457/3
TOLERANCES	DESIGNER DATE 1/21/51 SHEET OF SHEETS
DECIMALS	DRAWN BY C.H.
FRACTIONS	CHECKED BY
ANGLES	APPROVED BY <i>GP</i> B-

FIG. 9

Figure 10

BATTERY FABRICATION PHASE TEST OUTLINE

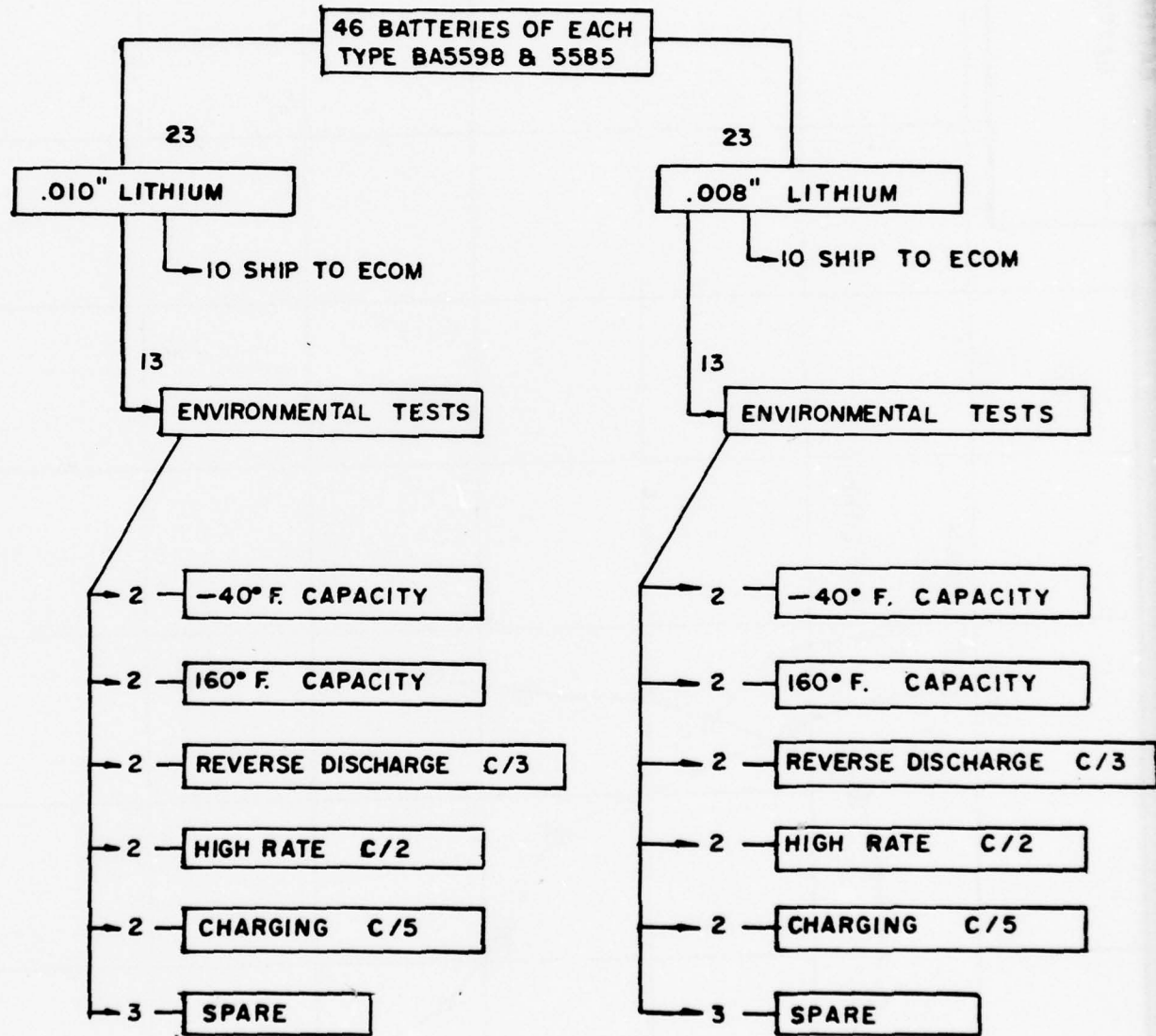

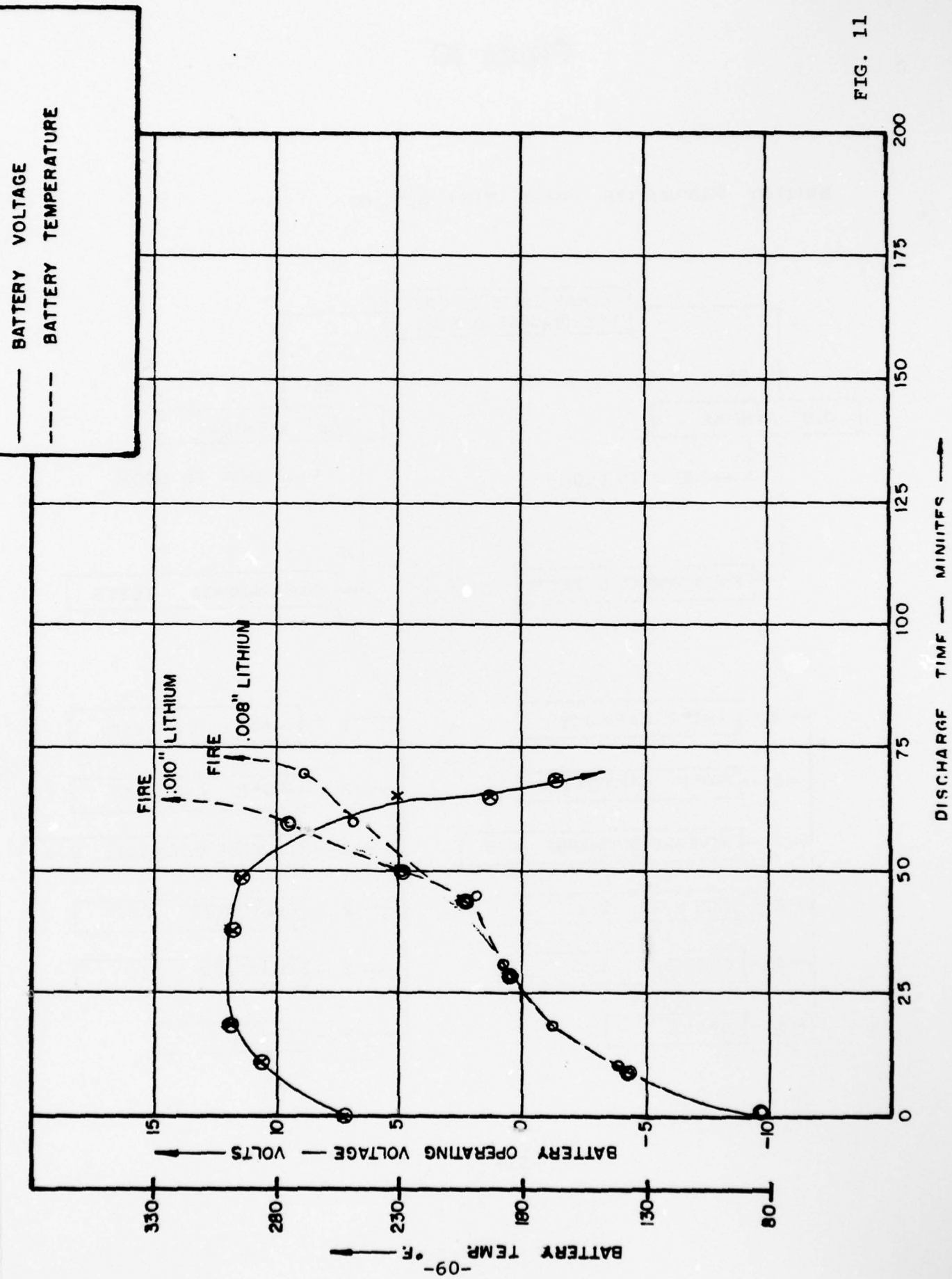

FIG. 11

BA-5598 ABUSE TEST

TYPICAL C/3 DISCHARGE (3.3 AMPERES)
 X — BATTERY VOLTAGE .008" LITHIUM
 O — BATTERY TEMP. .008" LITHIUM
 ⊗ — BATTERY VOLTAGE .010" LITHIUM
 ● — BATTERY TEMP. .010" LITHIUM

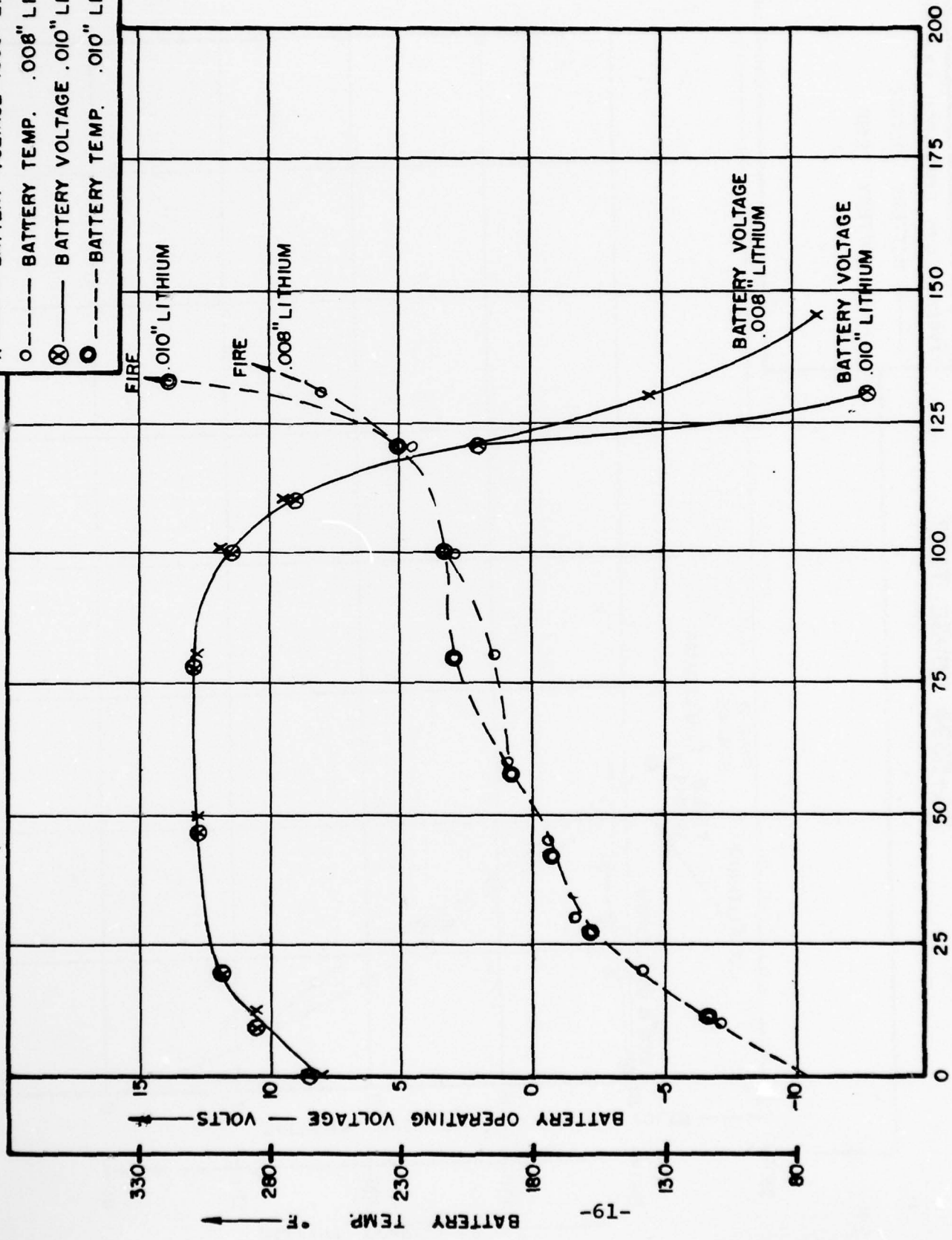

FIG. 12

BA-5598 ABUSE TEST

TYPICAL C/5 DISCHARGE (2.0 AMPS)
 — BATTERY VOLTAGE
 - - - BATTERY TEMP.

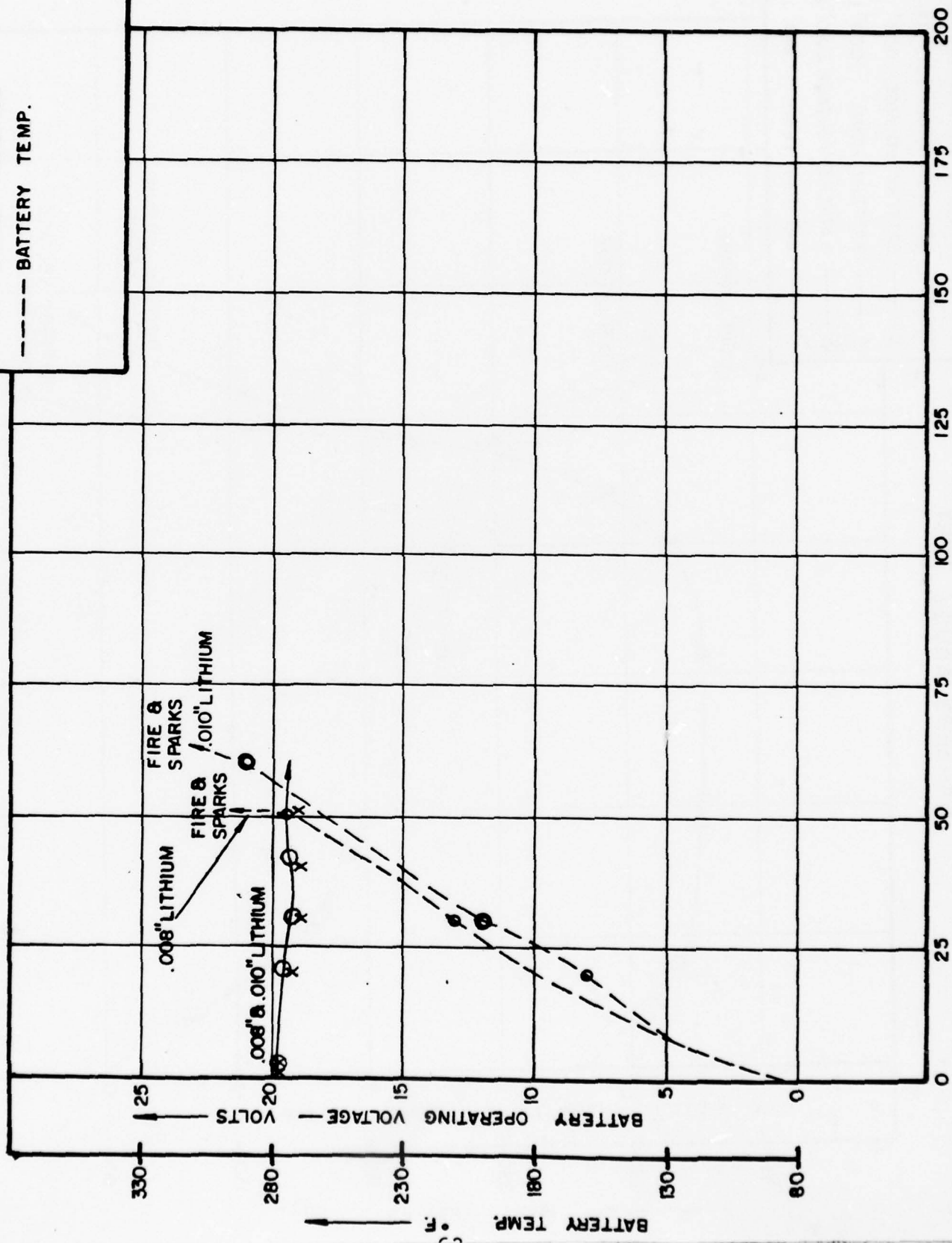

FIG. 13

BA-5585 ABUSE TEST

TYPICAL C/3 DISCHARGE (2.3 AMPS)
 — BATTERY VOLTAGE
 - - - BATTERY TEMPERATURE

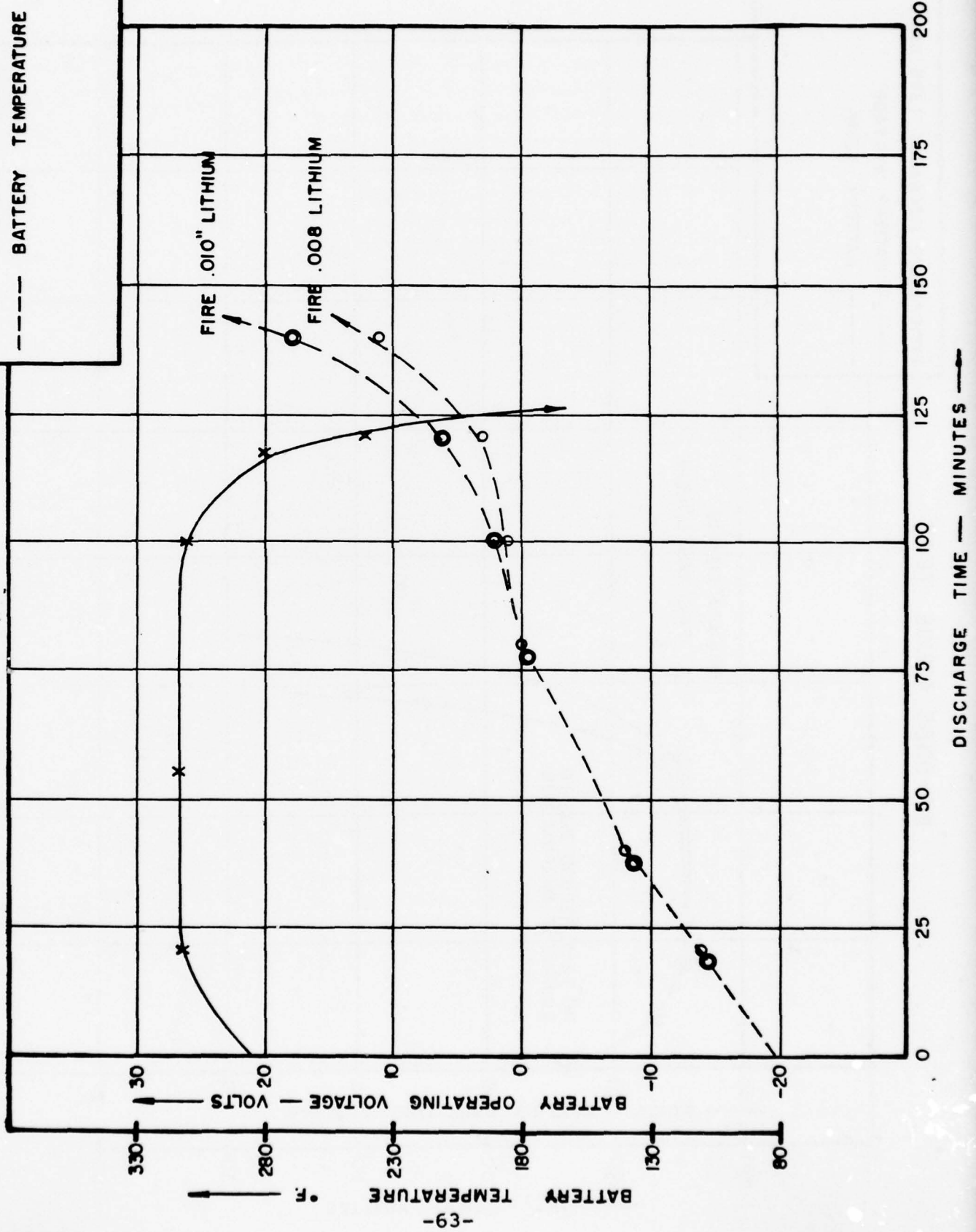

FIG. 14

BA-5585 ABUSE TEST

TYPICAL C/2 DISCHARGE (345 AMPS)

— BATTERY VOLTAGE
 - - - BATTERY TEMP.

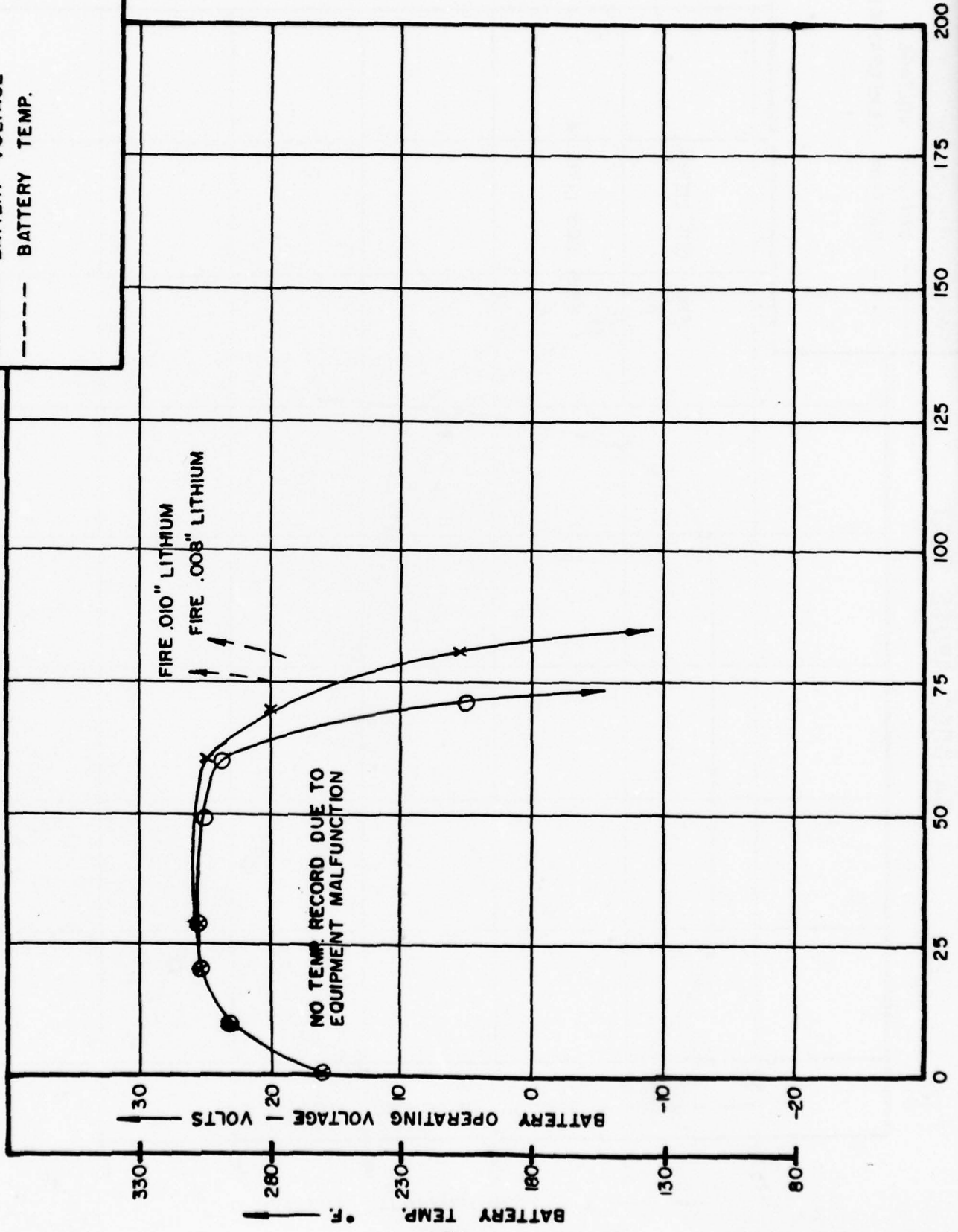

FIG. 15

BA-5585 ABUSE TEST

TYPICAL 1.38 AMP. CHARGE
 ▲ BATTERY VOLTAGE
 ● BATTERY TEMP.

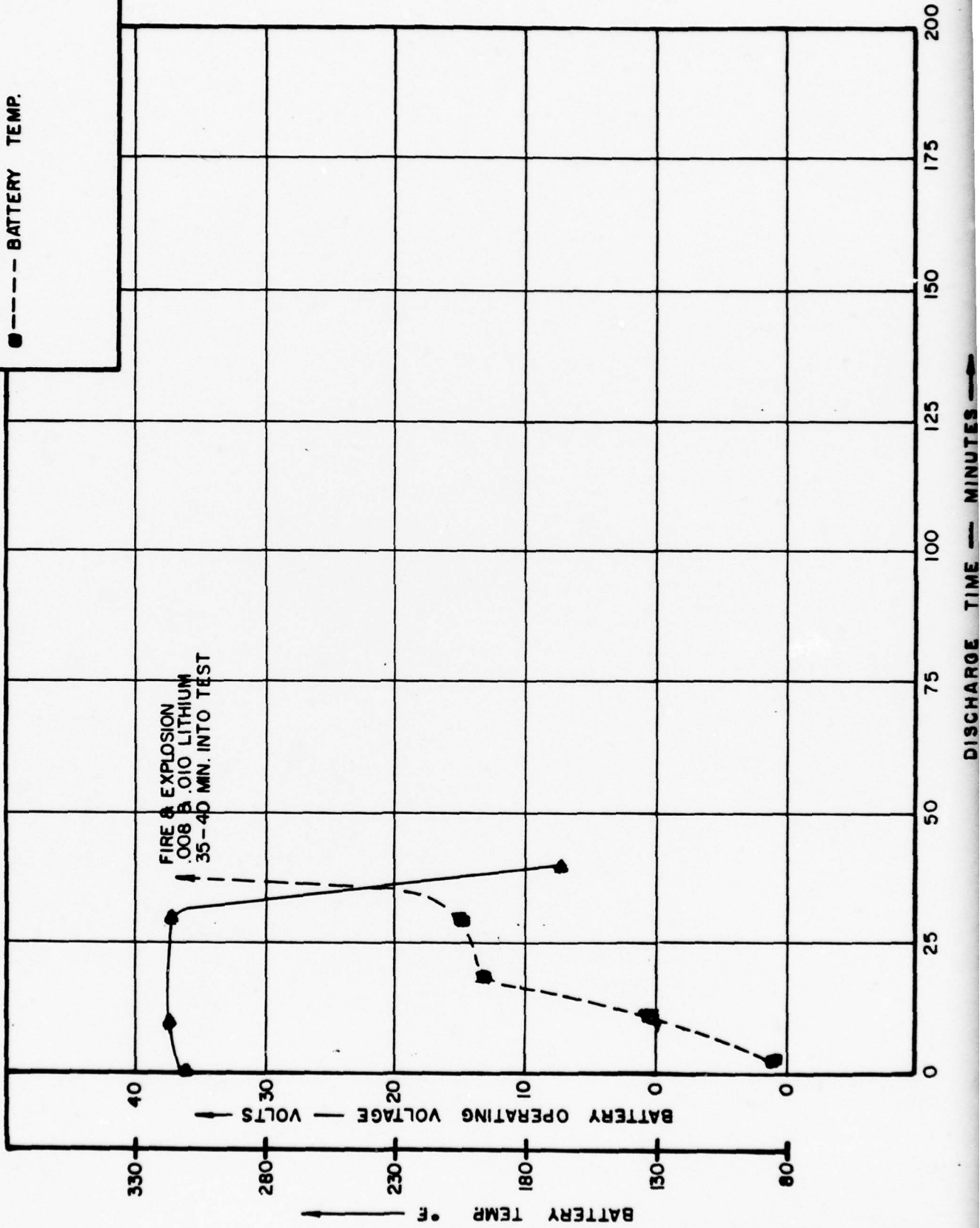
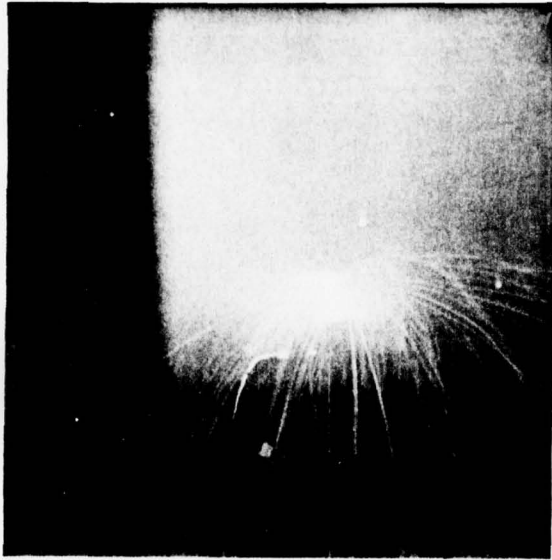

FIG. 16

BATTERY ABUSE TESTS - DURING Tests



BA 5585 Reverse Discharge
10/14/77 2.3 AMPS ($C/3$ Rate)



BA 5598 HIGH RATE DISCHARGE
3/N/25 5.0 AMPS ($C/2$ RATE)



BA 5585 Reverse Discharge
10/14/77 2.3 Amps ($C/3$ Rate)



BA 5585 AFTER
Reverse Discharge @
2.3 AMPS ($C/3$ Rate)

BATTERY CONDITION AFTER ABUSE TESTS
1.38 AMP CHARGE

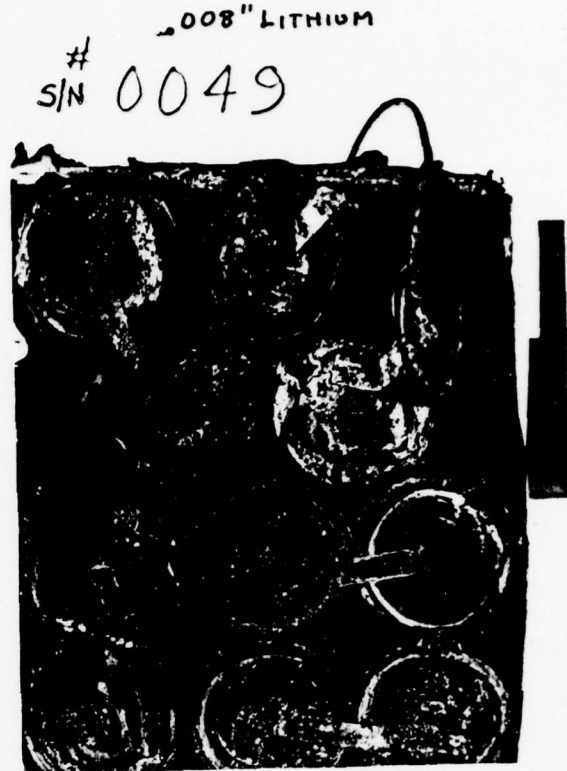
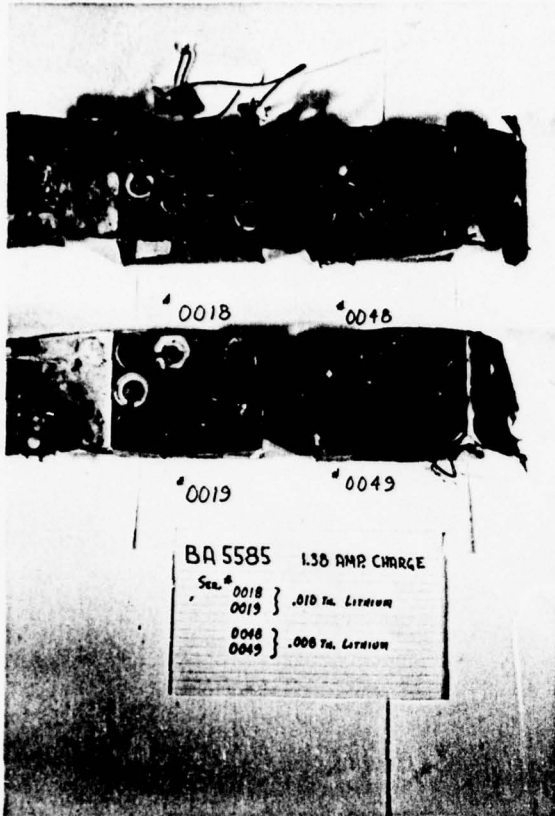

S/N 0018 .010\" LITHIUM

FIG. 18

BATTERY CONDITION AFTER ABUSE TESTS
BA 5585

BA-5585 3.15 AMP DISCHARGE

0015 }
0048 } 005.14
0045 }

.008" LITHIUM .010" LITHIUM
#053 L #022

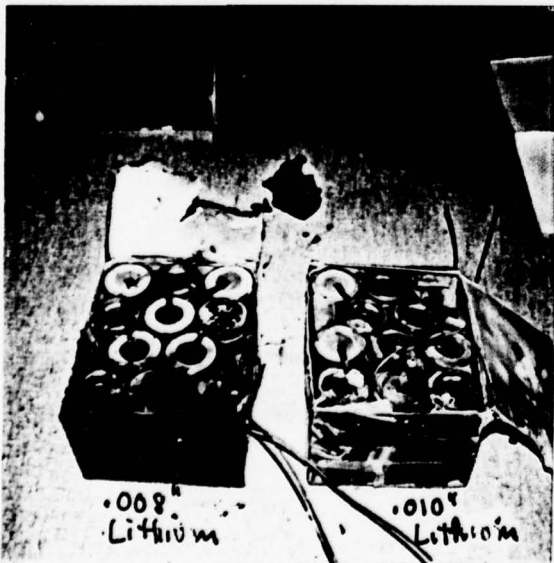
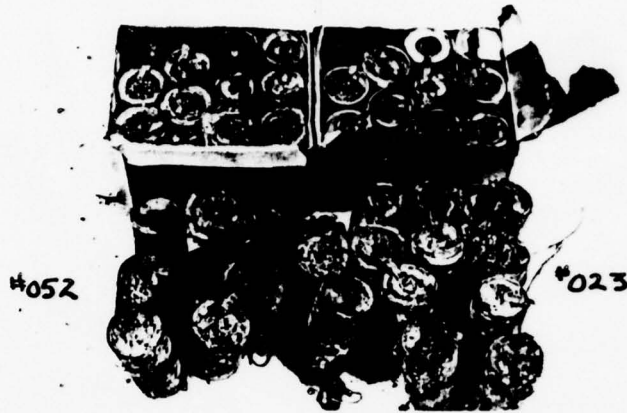

BA-5585
S/N 0021,0051
2.3 AMP REVERSE DISCHARGE

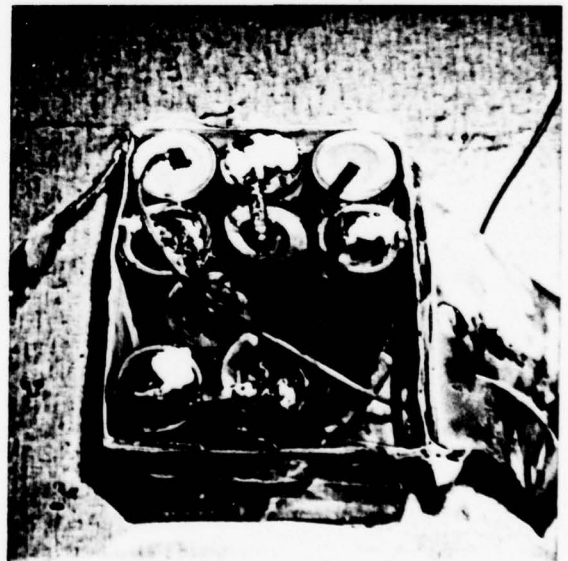

BA-5585 NOTE CELL VENT
S/N 0050 FROM TOP
.008" LITHIUM
2.3 AMP REVERSE DISCHARGE

BATTERY CONDITION AFTER ABUSE TEST

BA-5598

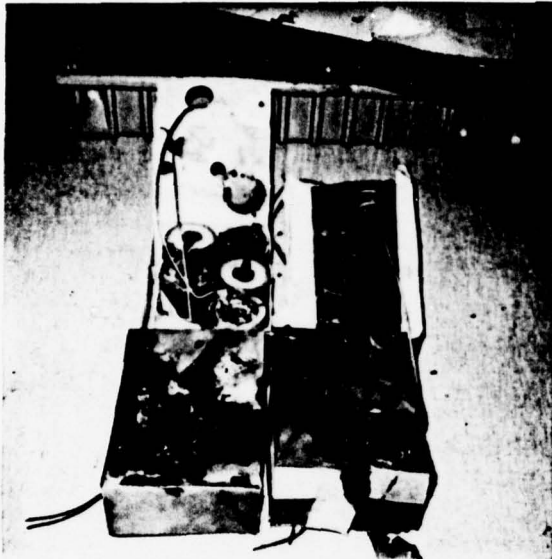

BA-5598 2.0 AMP CHARGE
S/N 128,150,120,121



BA-5598 5.0 AMP DISCHARGE
S/N 162,154,125

5.0 AMP DISCHARGE
.010" LITHIUM

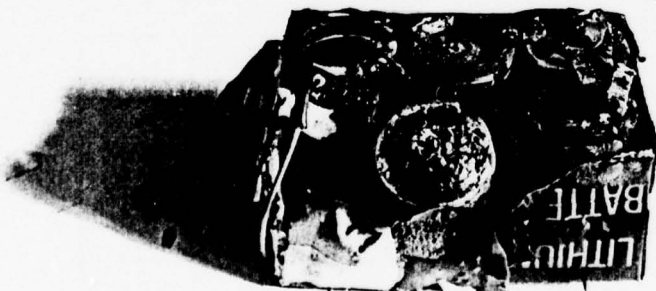

#0124



BA-5598 NOTE BULGING
S/N 0124 OF TOP OF
CELL
5.0 AMP DISCHARGE - .008" Lith.

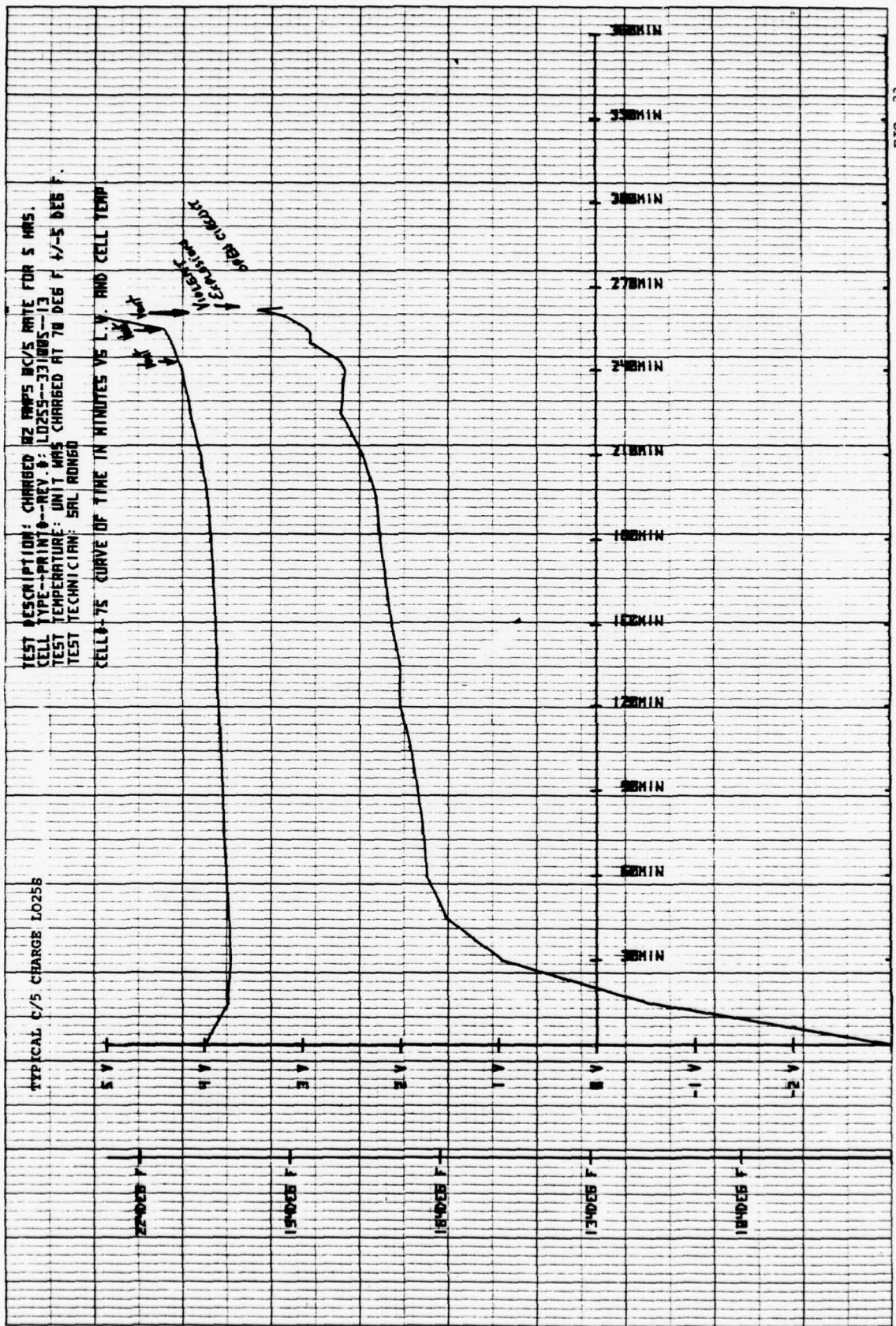
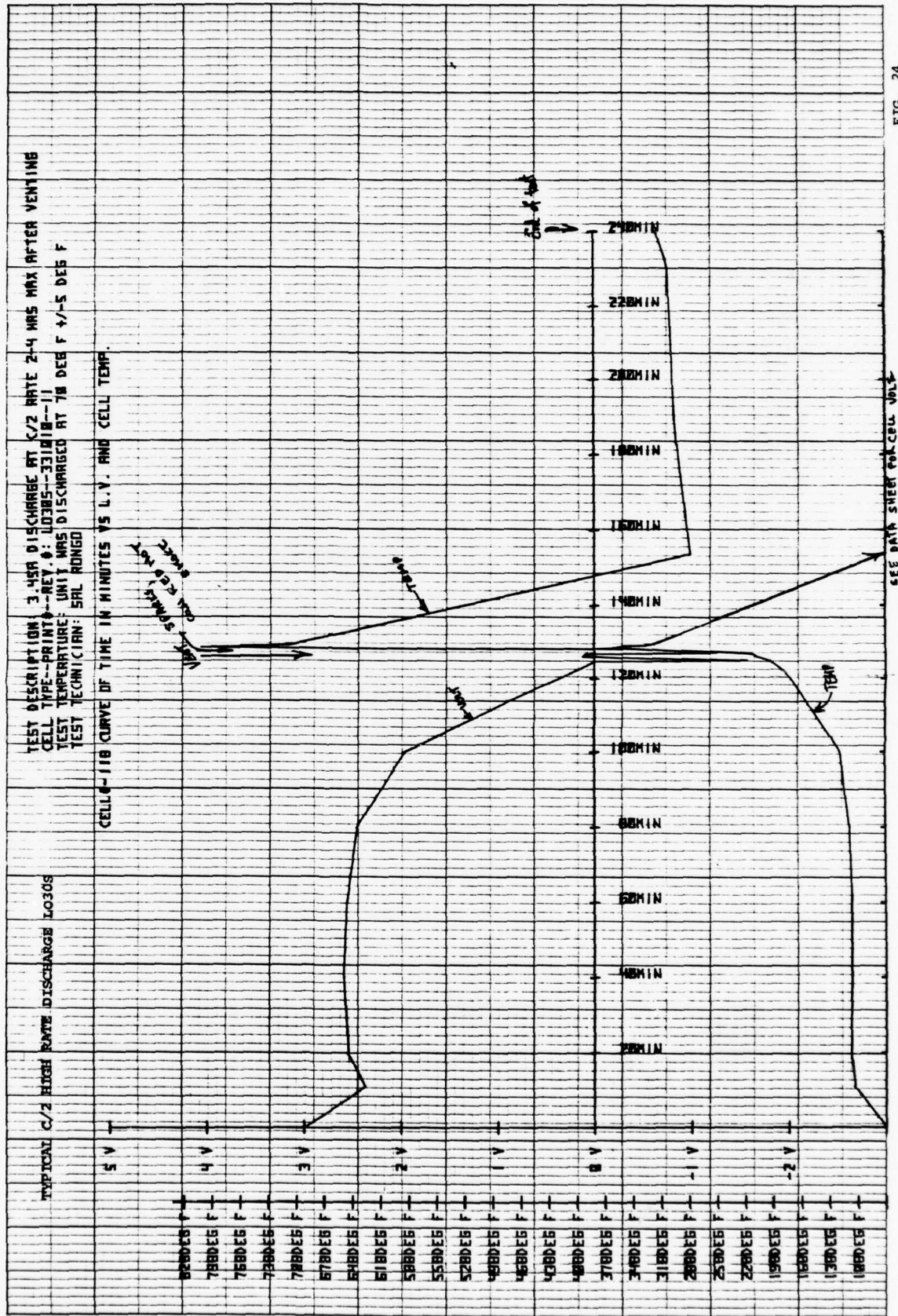

FIG. 23



TEST DESCRIPTION: 3.45A DISCHARGE AT C/2 RATE 2-4 HRS MAX AFTER VENTING
 CELL TYPE--PRINT--REV. 0: LO30S--33101B--II
 TEST TEMPERATURE: UNIT WAS DISCHARGED AT 78 DEE F +/-5 DEE F
 TEST TECHNICIAN: SFL RONGO

CELL 6-118 CURVE OF TIME IN MINUTES VS L.V. AND CELL TEMP.

TYPICAL C/2 HIGH RATE DISCHARGE LO30S

5 V
 4
 3
 2
 1
 0
 1 2 3 4 5 6 7 8 9 10 11 12 13 14 15 16 17 18 19 20 21 22 23 24 25 26 27 28 29 30 31 32 33 34 35 36 37 38 39 40 41 42 43 44 45 46 47 48 49 50 51 52 53 54 55 56 57 58 59 60 61 62 63 64 65 66 67 68 69 70 71 72 73 74 75 76 77 78 79 80 81 82 83 84 85 86 87 88 89 90 91 92 93 94 95 96 97 98 99 100 101 102 103 104 105 106 107 108 109 110 111 112 113 114 115 116 117 118 119 120 121 122 123 124 125 126 127 128 129 130 131 132 133 134 135 136 137 138 139 140 141 142 143 144 145 146 147 148 149 150 151 152 153 154 155 156 157 158 159 160 161 162 163 164 165 166 167 168 169 170 171 172 173 174 175 176 177 178 179 180 181 182 183 184 185 186 187 188 189 190 191 192 193 194 195 196 197 198 199 200 201 202 203 204 205 206 207 208 209 210 211 212 213 214 215 216 217 218 219 220 221 222 223 224 225 226 227 228 229 230 231 232 233 234 235 236 237 238 239 240

FIG. 24

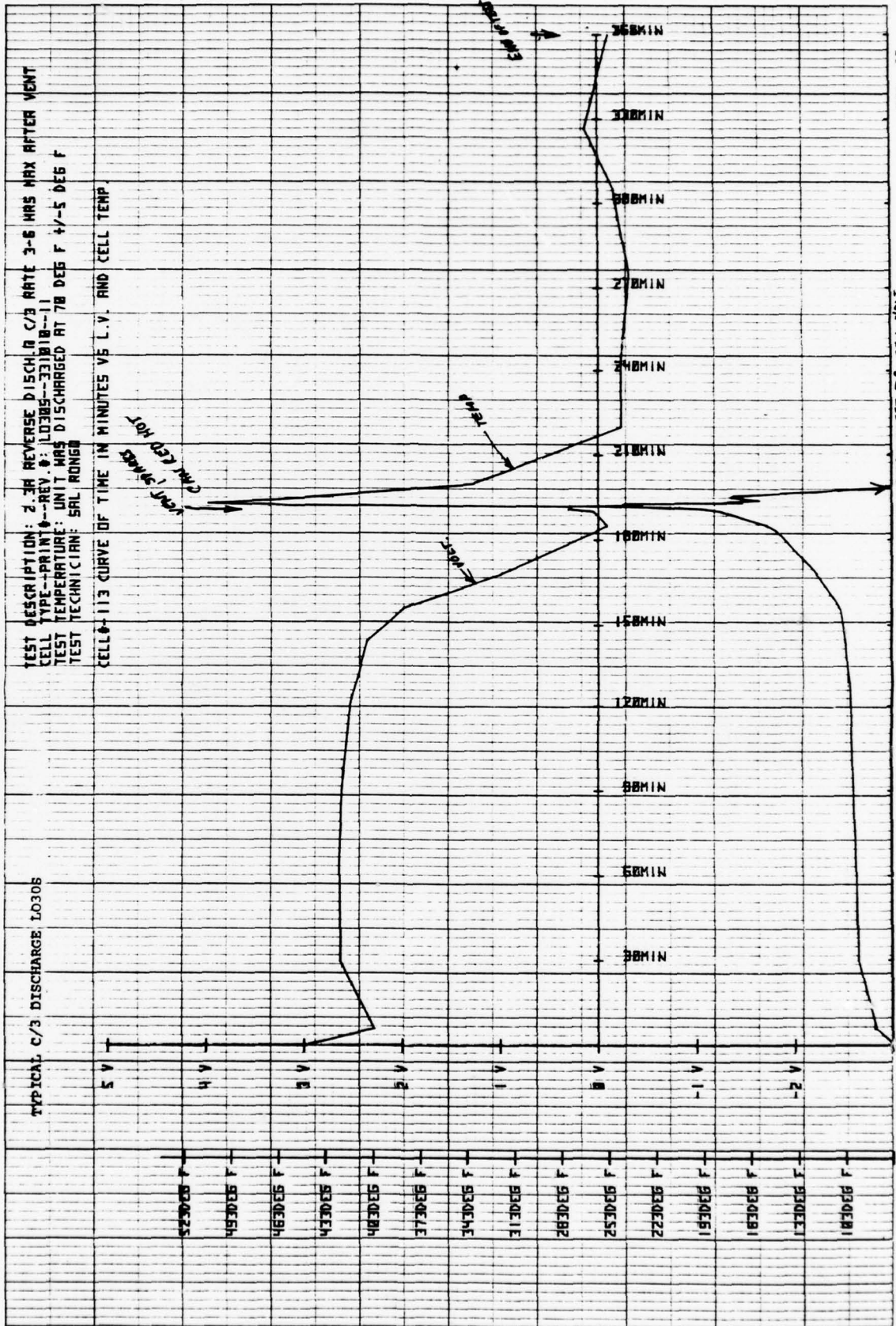

FIG. 25

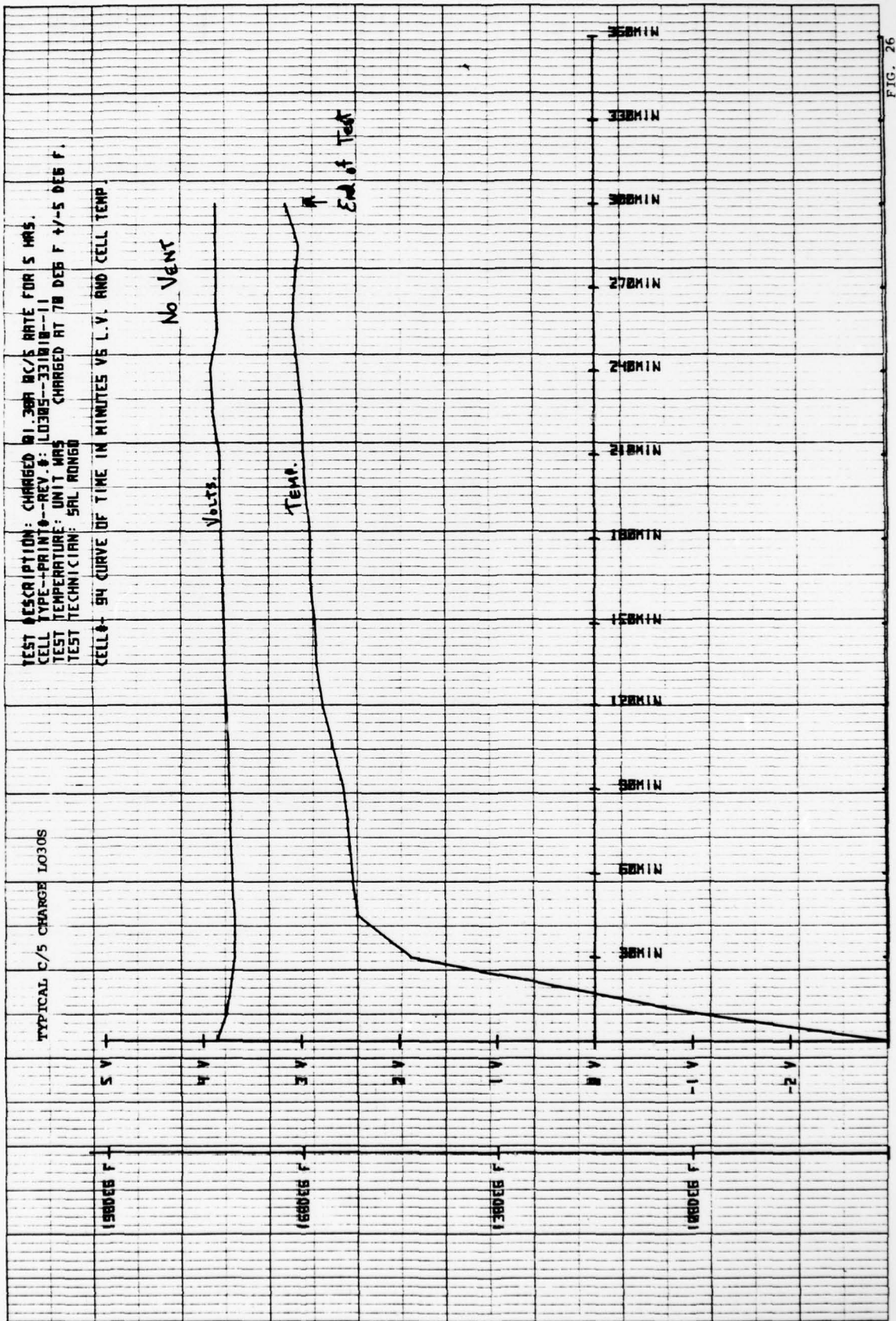

FIG. 26

ORGANIC ELECTROLYTE CELL TYPE --- L037S

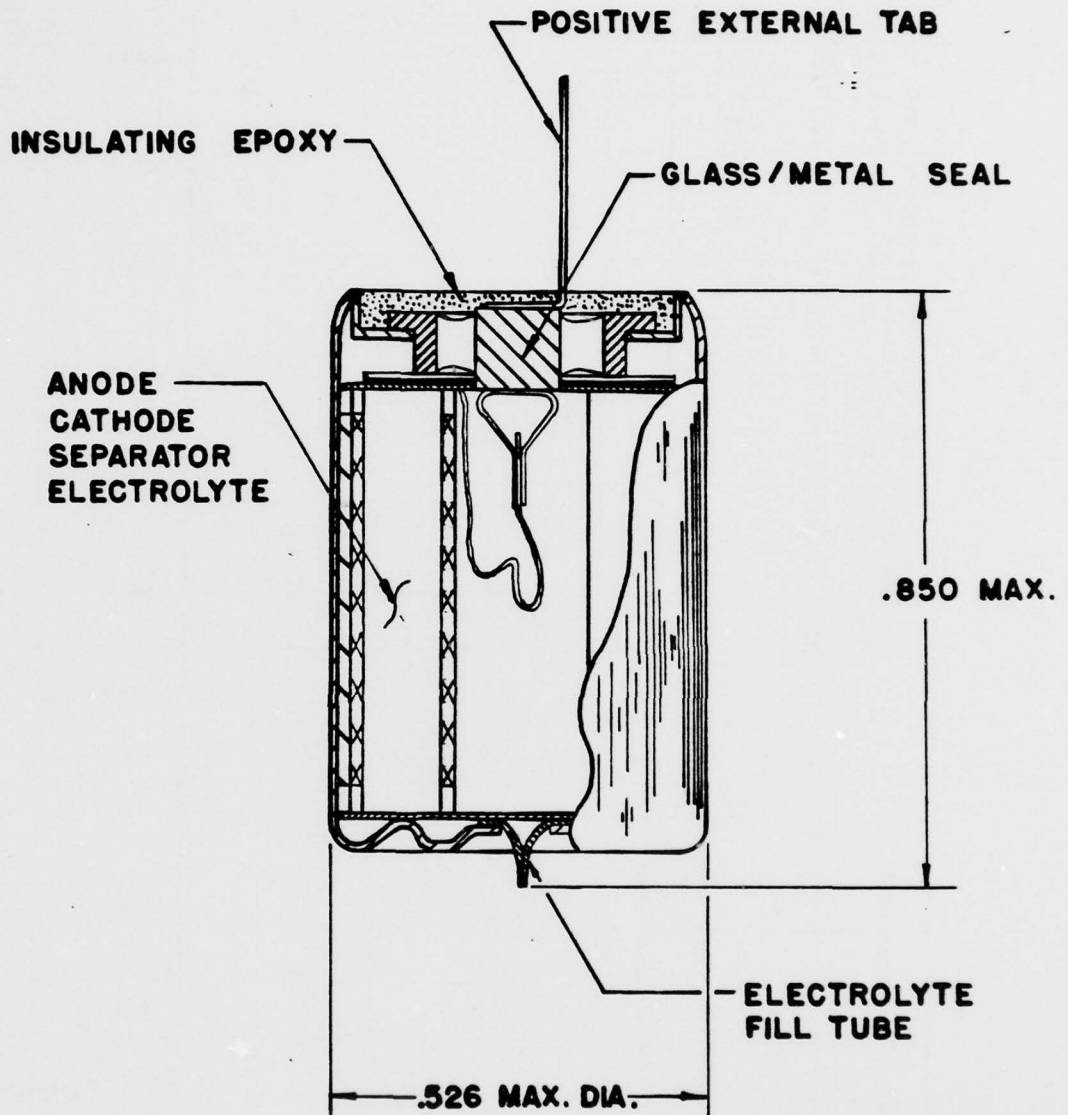

FIG. 27

-76-

11-13-78

Subject matter appearing on this page constitutes matter exempted from disclosure under the F.O.I.A., 5 U.S.C. 552(b) (4), and precluded from disclosure under 18 U.S.C. 1905.

Use or Disclosure of proposed data is subject to the restriction on the title page of this proposal.

LIMITED RIGHTS LEGEND: Contact No. ; Contactor: P. R. Mallory & Co. Inc.; Explanation of Original Rights Data Identification Method Used: The technical data subject to this restriction is circled.

C/3 (142 mg) HIGH RATE DISCHARGE
STORED FOR 30 DAYS AT 160°F. PRIOR TO TEST

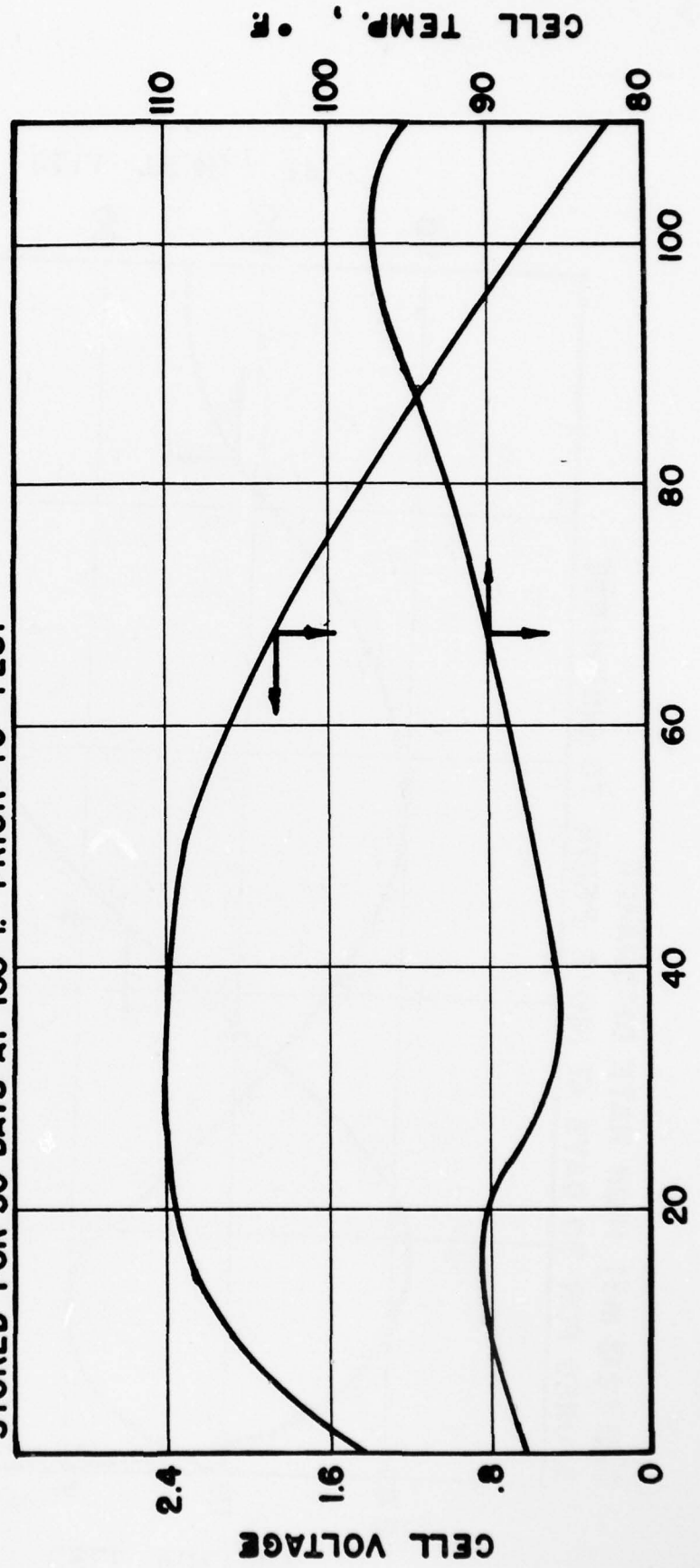

TIME, MINS.

FIG. 28

**C/2 (213 mg) HIGH RATE DISCHARGE
STORED FOR 30 DAYS AT 160°F. PRIOR TO DISCHARGE**

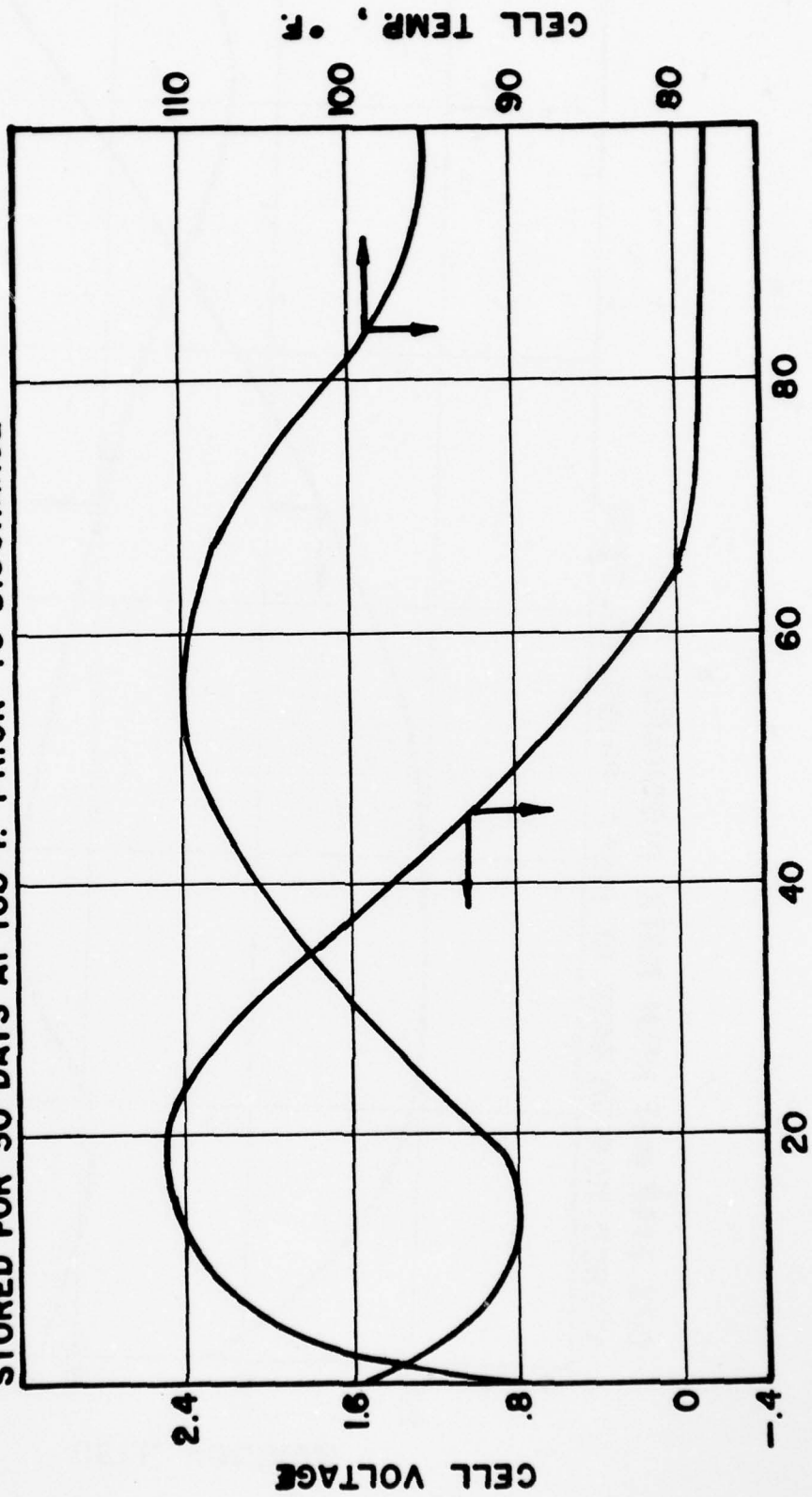

TIME, MINS.
FIG. 29

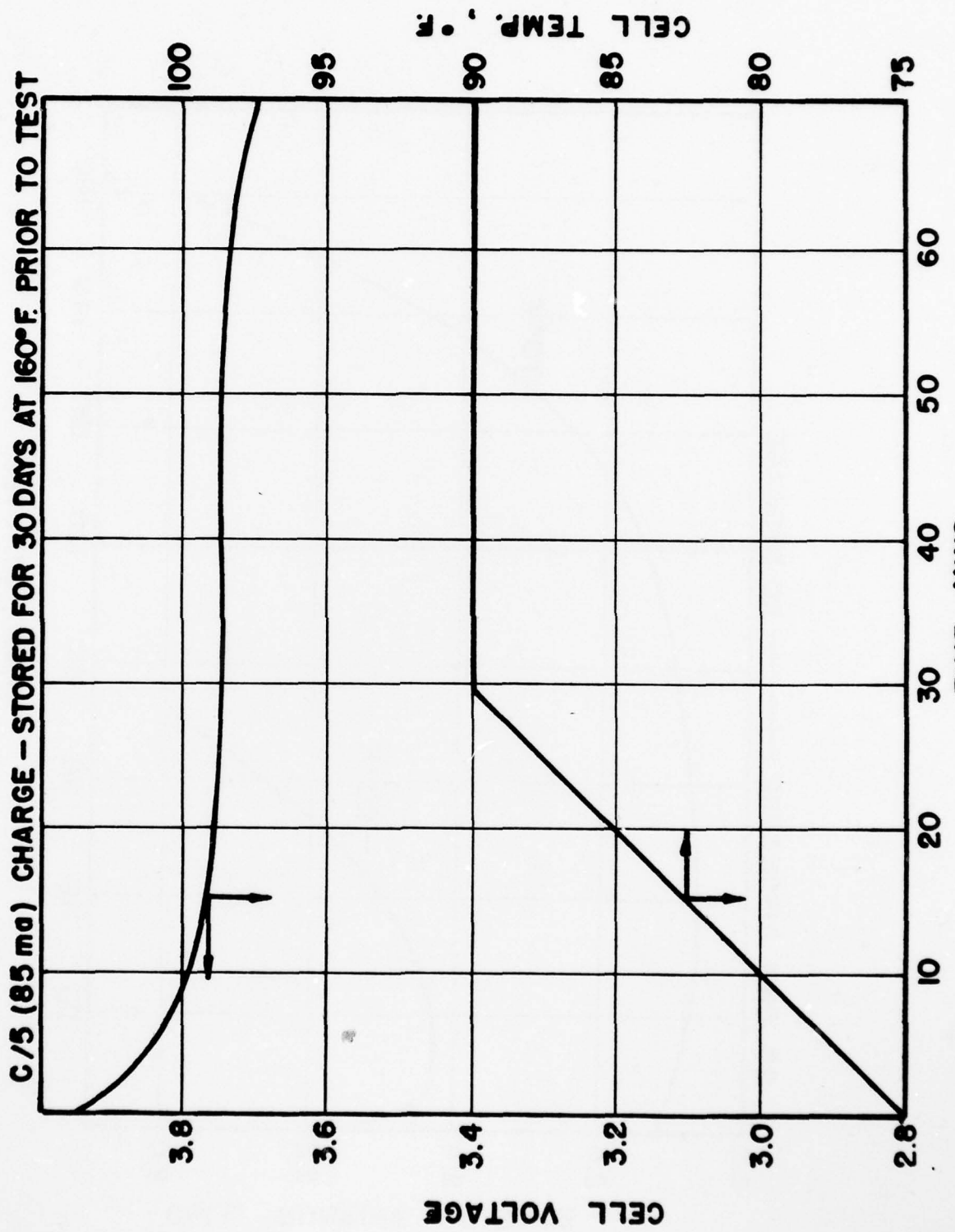
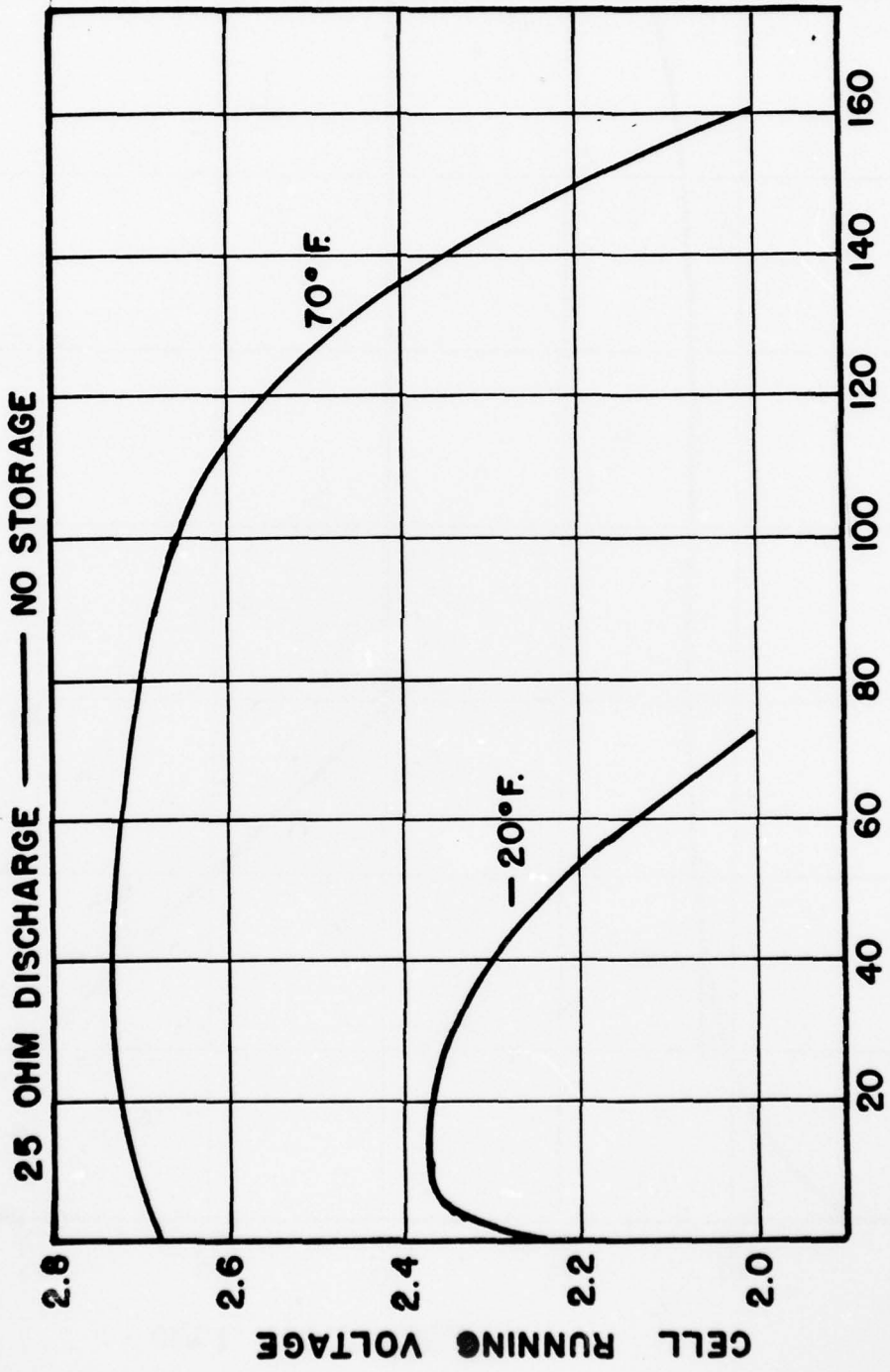

FIG. 30



TIME, MINUTES
FIG. 31

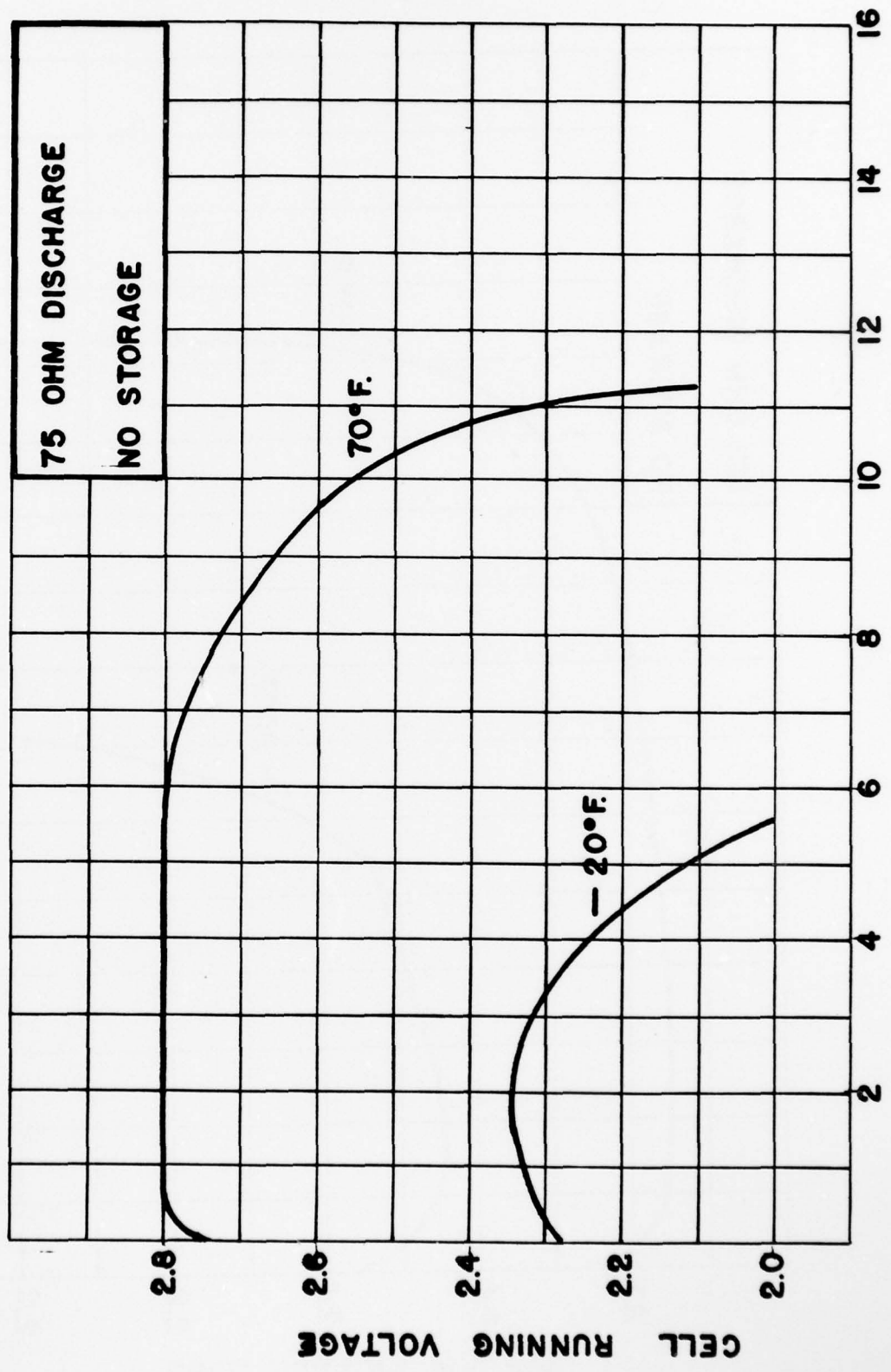

FIG. 32
TIME, HOURS

CELL RUNNING VOLTAGE

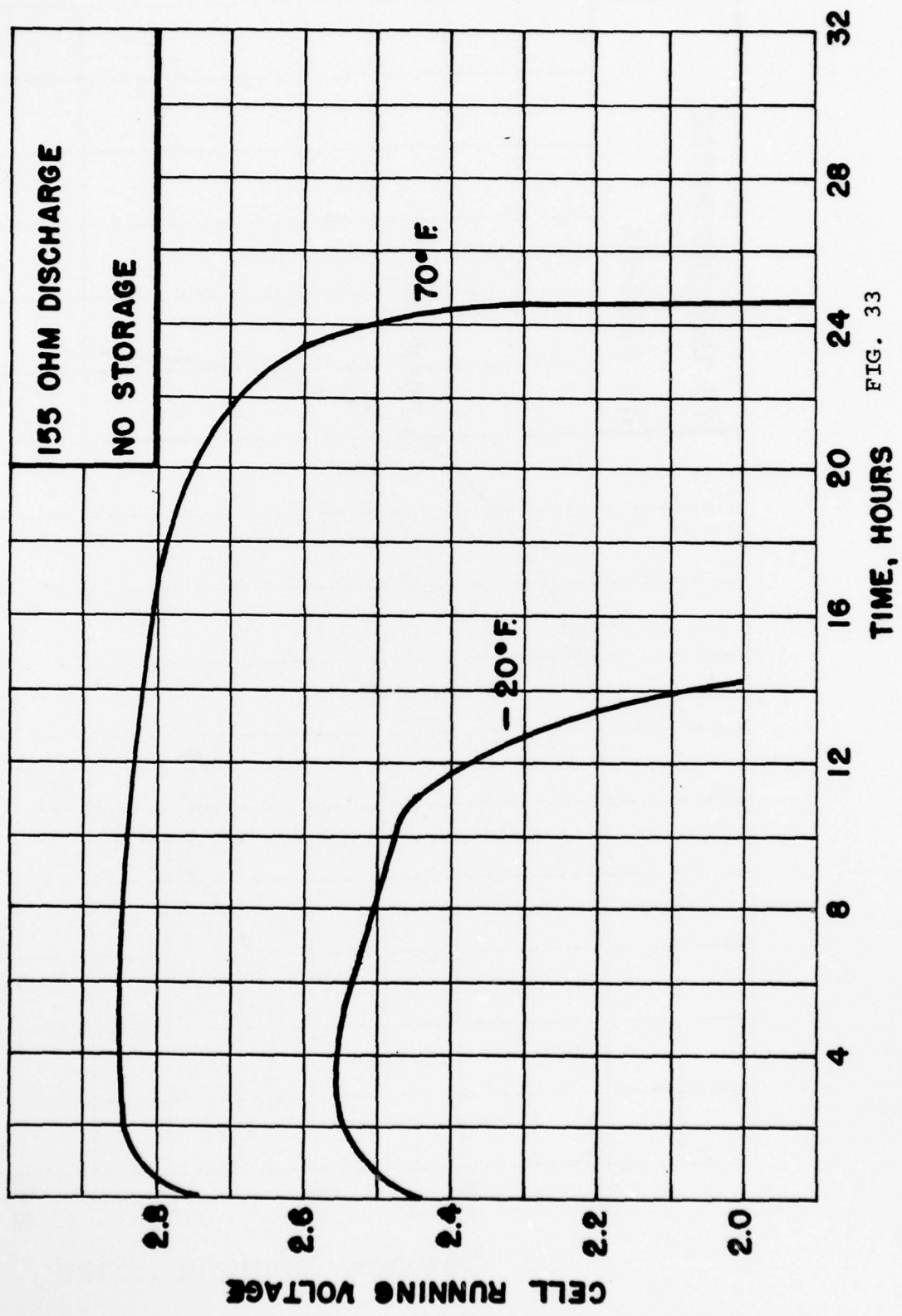

FIG. 33

CELL RUNNING VOLTAGE

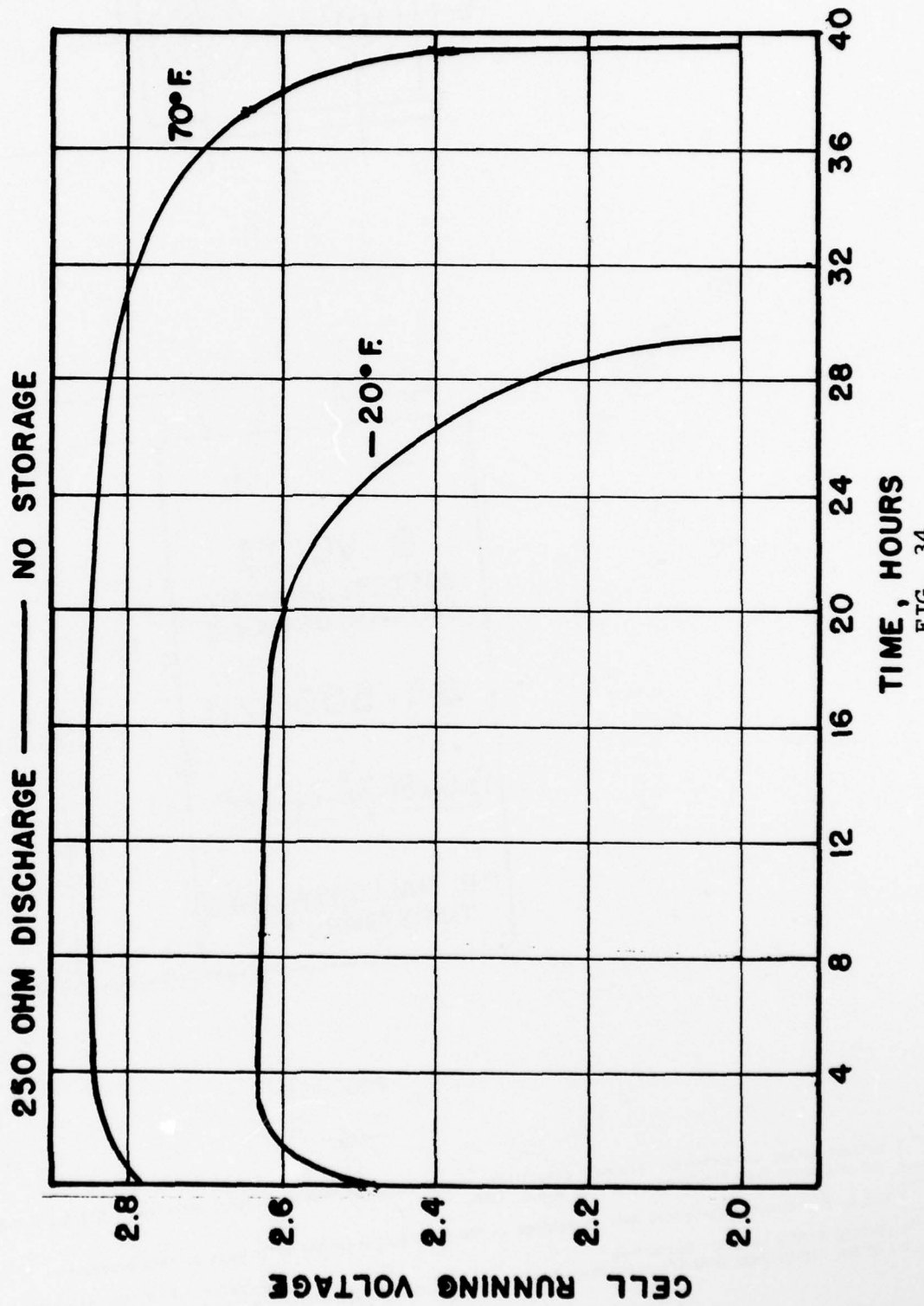

FIG. 34

LITHIUM ORGANIC BATTERY TYPE BA-5090 ()/U

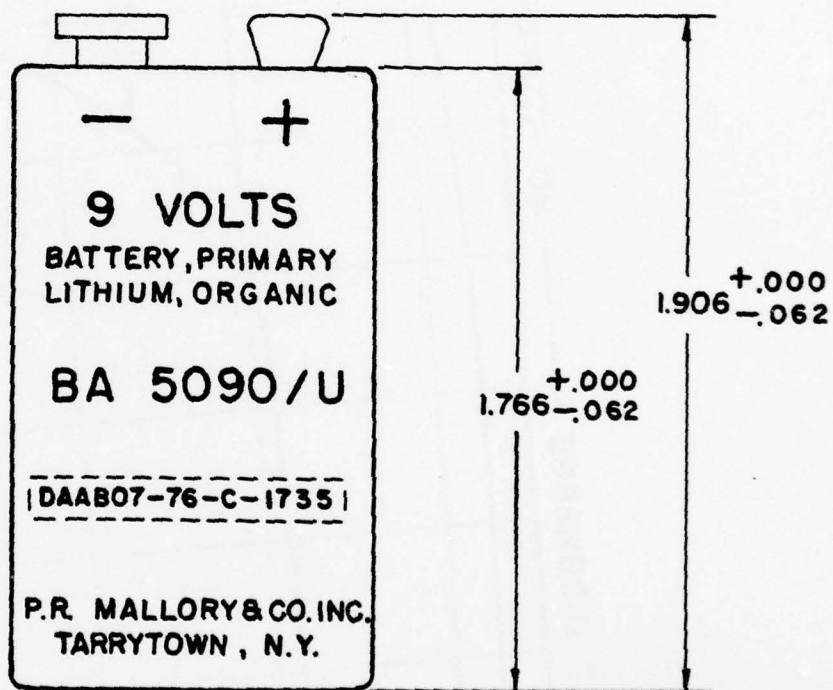
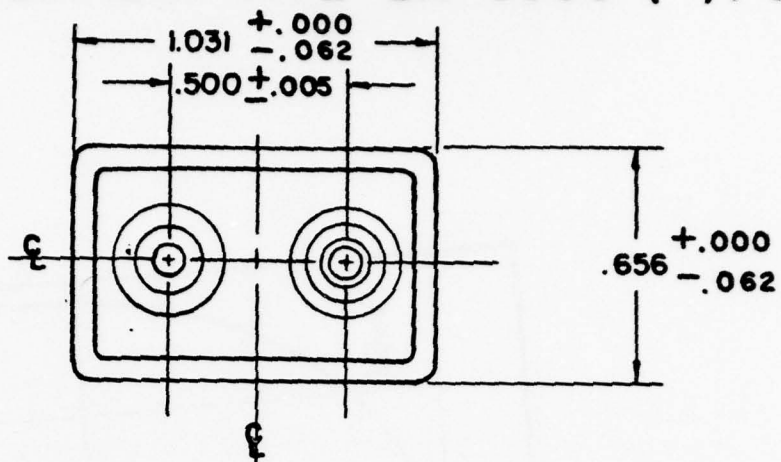

FIG. 35

11-13-78

- Subject matter appearing on this page constitutes matter exempted from disclosure under the F.O.I.A., 5 U.S.C. 552(b) (4), and precluded from disclosure under 18 U.S.C. 1905.
- Use or Disclosure of proposed data is subject to the restriction on the title page of this proposal.
- LIMITED RIGHTS LEGEND: Contact No. ; Contactor: P. R. Mallory & Co. Inc.; Explanation of Limited Rights Data Identification Method Used: The technical data subject to this restriction is circled.

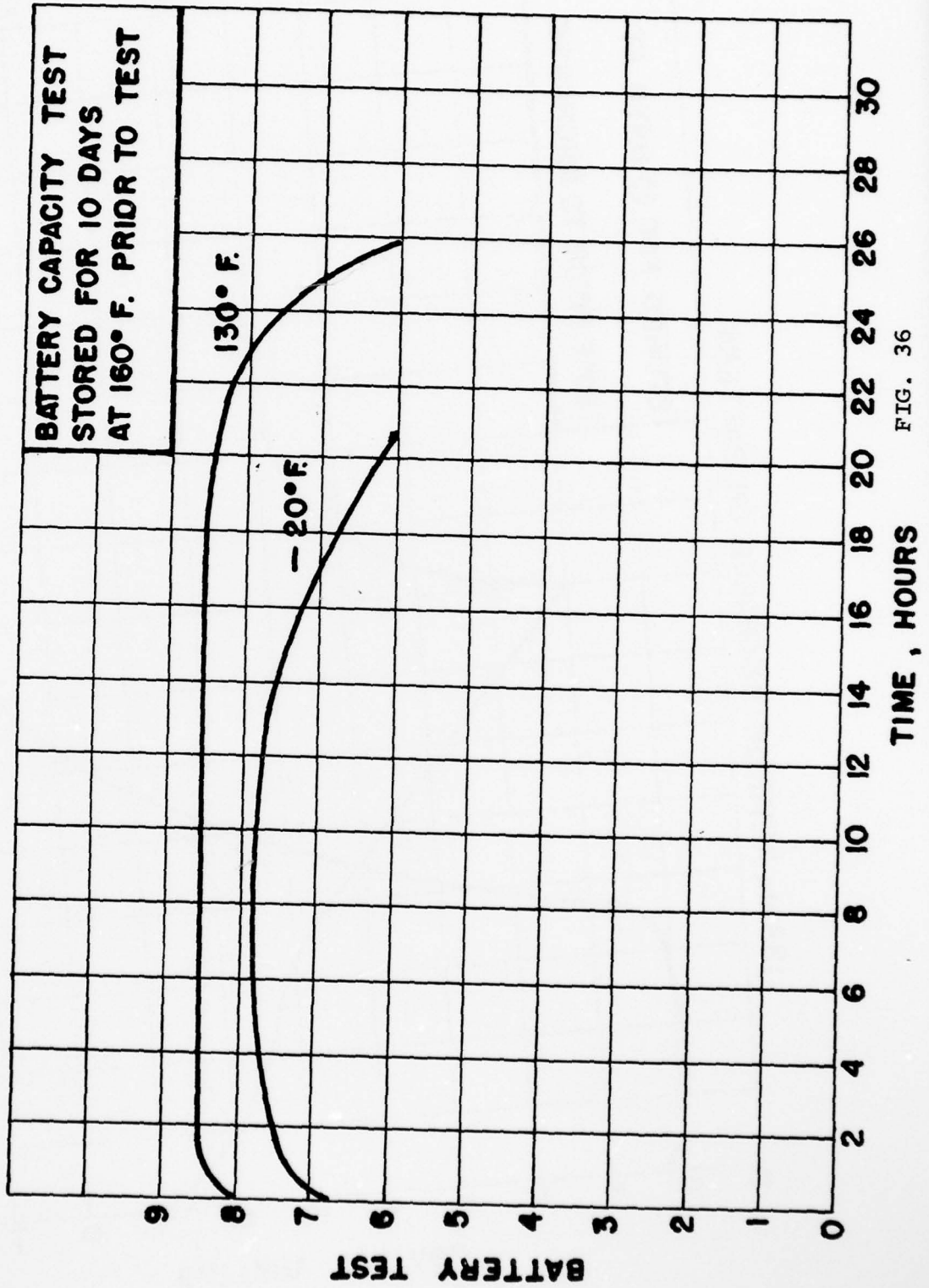

FIG. 36

TIME, HOURS

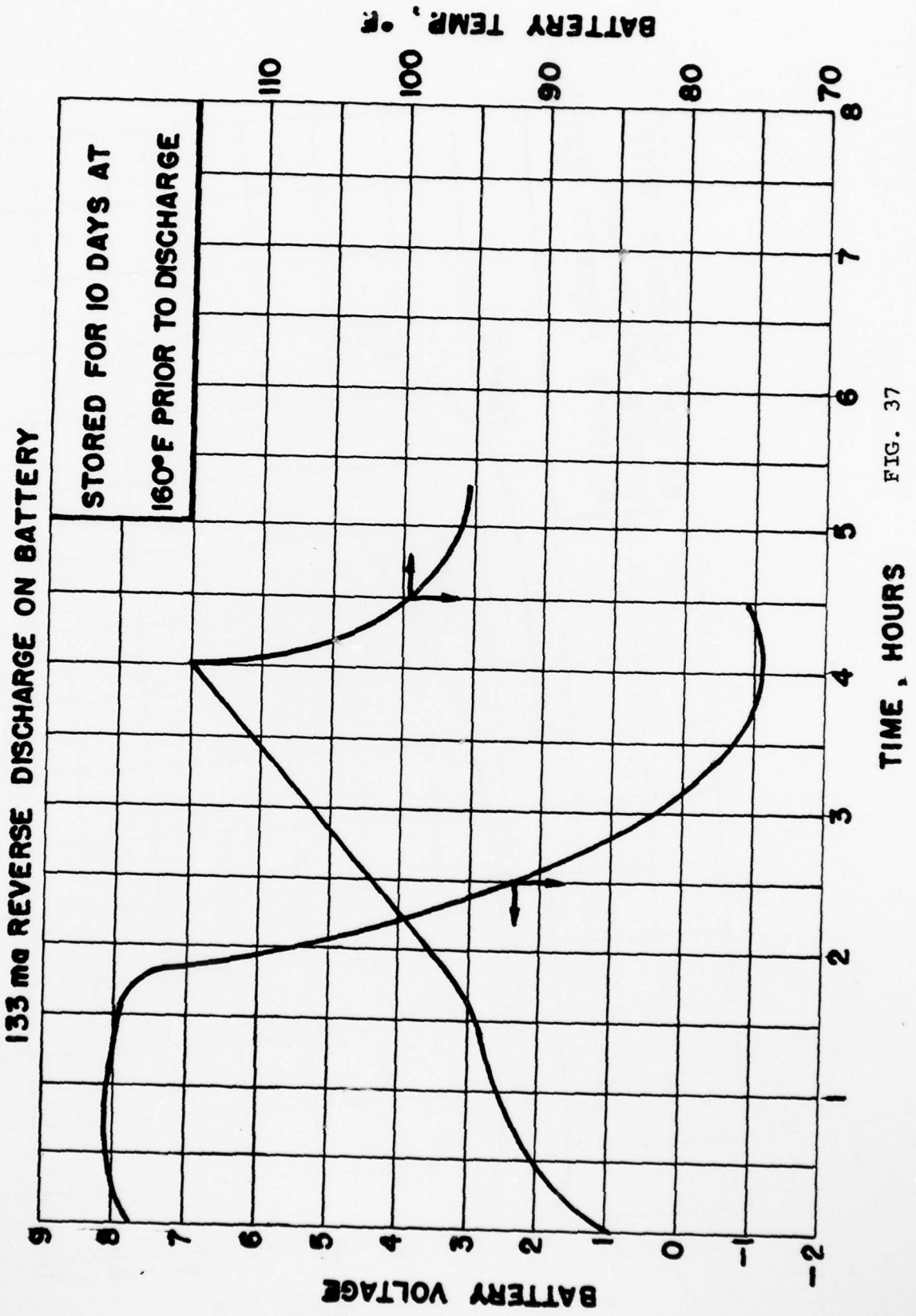

FIG. 37

200 mg HIGH RATE DISCHARGE ON BATTERY

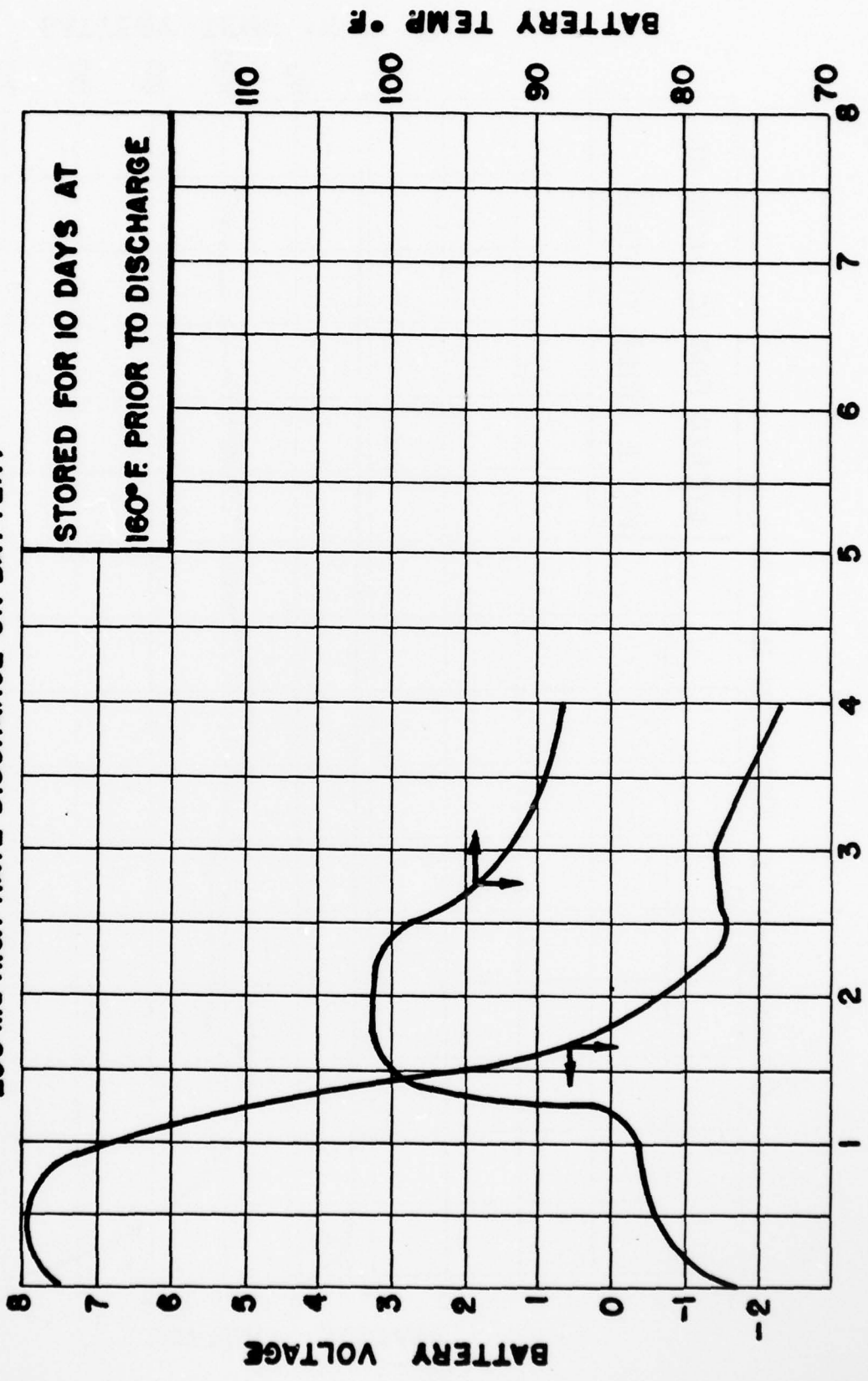

FIG. 38

80 mg CHARGE TEST ON BATTERY

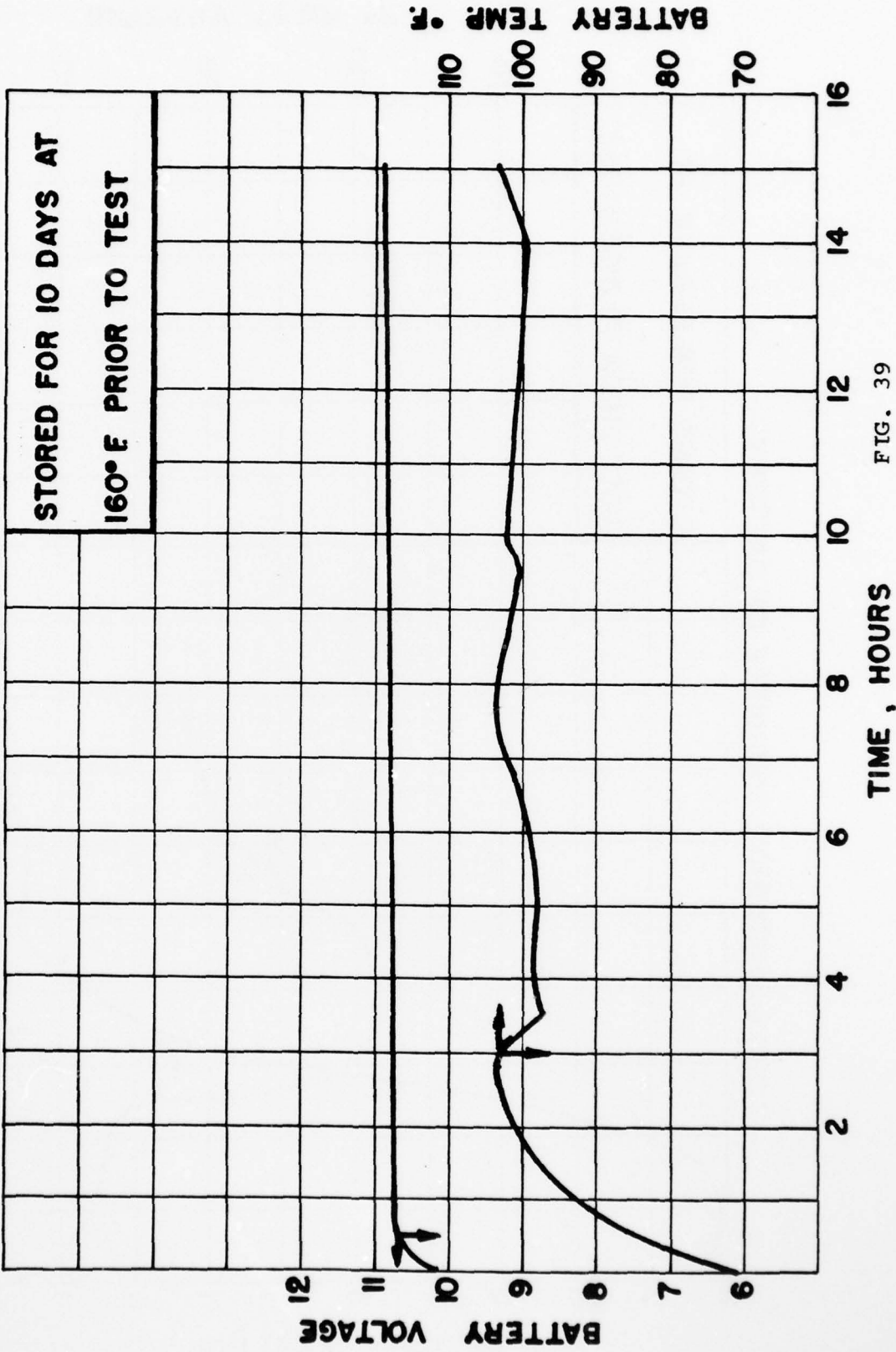

FIG. 39

POWER SOURCES TECHNICAL AREA
US ARMY ELECTRONICS TECHNOLOGY &
DEVICES LABORATORY (ECOM)

24 June 1975

TECHNICAL GUIDELINES FOR HERMETICALLY SEALED
LITHIUM CELLS

1. SCOPE:

The purpose of this program is to modify and improve the safety characteristics of the lithium organic electrolyte sulfur dioxide system and to develop a hermetically sealed cell which will eliminate any leakage of sulfur dioxide from that cell.

2. TECHNICAL APPROACH:

The contractor shall conduct investigations on developing a hermetically sealed lithium-organic electrolyte-sulfur dioxide cell which will demonstrate a high degree of safety under any condition to which the cells may be exposed. Consideration should be given to but not necessarily limited to venting, fusing and dioding of the cells and batteries. Materials to be used in the hermetical seal shall be tested for compatability with the electrolyte and sulfur dioxide. Cells and batteries will be evaluated for safety and gas leakage characteristics. The batteries shall be potted when necessary and in such a manner that will not interfere with the operation of the safety mechanisms.

3. REQUIREMENTS:

3.1 Cell Size

Three cell sizes are to be considered for this study. Cells should be of the configuration required for the fabrication of the Battery BA-5598()/U, BA-5585()/U and the BA-5090()/U in accordance with SCS 459 dated 17 May 1974.

3.2 Venting Mechanism

The venting mechanism when employed in the cell shall operate at 400 psia maximum. No material other than electrolyte or sulfur dioxide shall be ejected from the cell. Cell explosions or fires shall not occur at any time.

3.3 Cell Case Material

The cell case material for each cell configuration shall be designed so that its bursting strength exceeds by 25% the pressures developed by shorting the cell under any test condition set forth in this specification.

AD-A064 327

MALLORY BATTERY CO TARRYTOWN N Y
PRIMARY LITHIUM ORGANIC ELECTROLYTE BATTERY BA-5090 ()/U, BA-5--ETC(U)
DEC 78 J BARRELLA, M KUMBHANI

F/G 10/3

DAAB07-76-C-1735

UNCLASSIFIED

DELET-TR-76-1735-F

NL

2 OF 2

AD
A064327



END
DATE
FILMED

4 --79
DDC

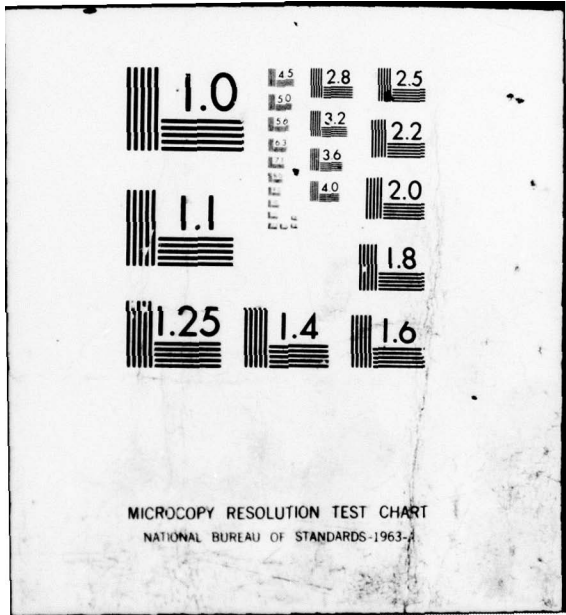

TECHNICAL GUIDELINES FOR HERMETICALLY SEALED LITHIUM CELLS (CONT)

3.4 Cell Weight Loss and Leakage

There shall be no cell weight loss when the cell is weighed at ambient temperature after any or all of the environmental tests of par 3.6 nor shall there be any evidence of leakage.

3.5 Battery Construction

Each battery with the exception of the BA-5090()/U shall have a replaceable fuse. The BA-5598()/U and BA-5585()/U will open circuit at a minimum current of C/3.

3.5.1 Battery Construction Materials. The battery case potting and other materials used shall be non-flammable.

3.6 Environmental Tests

Cells and batteries shall deliver standard capacity after environmental tests performed in the sequence given.

3.6.1 Temperature Shock. In accordance with MIL-STD-810B, Method 503, for five cycles (omit Step 9).

3.6.2 Shock. In accordance with MIL-STD-810B, Method 516, Procedure I, Curve 516-2, for ground equipment. (Do not operate during or after test).

3.6.3 Vibration. In accordance with MIL-STD-810B, Method 514, Equipment Category (h), Procedure X, Curves AA and AQ, Time Schedule IV. (Do not operate during or after test).

3.6.4 Altitude. In accordance with MIL-STD-810B, Method 500, Procedure II, (omit Step 5; in Step 6, return the chamber to standard ambient conditions).

3.7 Electrical Requirements, Cells

Each of the cell types shall be capable of delivering capacities equivalent to that called for in its respective Technical Specification Sheets of SCS 459 dated 17 May 1974 under any condition called for in that specification.

In addition the cells for each of the battery types shall demonstrate the following minimum ampere hour capacities when discharged at the 24 hour rate to a 2.0 volt cutoff after any or all conditions specified in these Technical Guidelines.

TECHNICAL GUIDELINES FOR HERMETICALLY SEALED LITHIUM CELLS (CONT)

<u>Cell</u>	<u>Discharge</u>		<u>Temperature</u>
	R.T.	160°F	-40°F
BA-5598()/U capacity	9.0	8.0	5.0
BA-5585()/U "	6.5	5.7	3.5
BA-5090()/U "	0.6	.53	.33

4. PRELIMINARY DESIGN FABRICATION PHASE:

The contractor shall fabricate one hundred (100) cells of each type for Batteries BA-5598()/U, BA-5585()/U and BA-5090()/U or a total of three hundred (300) cells. Forty (40) of each type or a total of one hundred twenty (120) will be selected at random for shipment to ECOM. The remainder will be tested in the following manner.

4.1 Environmental Tests

Prior to conducting the environmental tests all cells shall be weighed to the nearest milligram. All cells shall then be subjected to the environments of paragraph 3.6 in the order prescribed in para 3.6. At the conclusion of all the tests the cells shall again be weighed to the nearest milligram to then determine the weight loss if any.

4.2 High Temperature Storage

After undergoing the environmental tests of para 4.1 above all cells of each type will be reweighed to the nearest milligram and the weight for each cell recorded. The cells are stored at 160°F for 1 month. The cells will be removed, cooled for 1 hour in a dry atmosphere and weighed immediately. Weights will then be recorded and checked for compliance with para 3.4.

4.3 Temperature Tests - Room Temperature

After undergoing the above tests ten (10) cells of each type cell for the BA-5598()/U, the BA-5585()/U and the BA-5090()/U will be selected at random and discharged at the twenty four (24) hour rate at room temperature. The cells will be stabilized at that temperature for at least one hour prior to discharge. The cell discharge will be continuously monitored to a voltage cutoff of 2.0 volts. The ampere hour capacity of each cell shall conform to or exceed that given in para 3.1 of this specification.

4.4 High Temperature

Ten (10) cells of each type cell for the BA-5590()/U, the BA-5585()/U, and the BA-5090()/U will be randomly selected from the remaining cells that have undergone the environments of para 4.1. The cells will be stored at 160°F for a minimum of four (4) hours and then discharged at the same resistive load selected for the room temperature tests for that particular cell.

TECHNICAL GUIDELINES FOR HERMETICALLY SEALED LITHIUM CELLS (CONT)

The cell discharge will be continuously monitored to a voltage cutoff of 2.0 volts. The ampere hour capacity of each cell shall conform or exceed those high temperature discharge figures given for each type cell in para 3.7 of this specification.

4.5 Low Temperature

All of para 4.4 shall apply except that the cells shall be stored and discharged at -40°F.

4.6 Reverse Discharge

Ten (10) cells of each type BA-5598, BA-5585()/U and BA-5090()/U shall be reversed discharged by placing each cell in series with a power supply and driving it at a C/3 rate until venting occurs. Time to venting, cell temperatures, voltages and current will be recorded. Tests will be conducted under room temperature conditions. The cell shall comply with conditions of para 3.2.

4.7 High Rate Discharge

Ten (10) cells of each type BA-5598()/U, BA-5585()/U and BA-5090()/U shall be discharged at a C/2 rate. Temperature, voltages, current shall be recorded. The tests will be conducted at room temperature. The cell shall comply with the condition of para 3.2.

4.8 Charging Test

Ten (10) cells of each type BA-5598()/U, BA-5585()/U and the BA-5090()/U shall be charged at a C/5 rate. Temperature, voltages and current shall be recorded. The test will be conducted at room temperature and shall comply with the condition of para 3.2.

5. FABRICATION PHASE:

Upon approval of the Preliminary Design Fabrication phase the contractor will fabricate twenty five (25) batteries of each design, the BA-5598()/U; BA-5585 and the BA-5090()/U. The batteries that are fused shall have their fuses by passed for the purposes of the following tests:

Environmental Tests

All batteries shall have undergone all the environments given in para 3.6 in the order specified.

Electrical Tests

Ten (10) batteries of each type will be placed in 160°F storage for 10 days. At the end of the storage period the batteries will be removed

TECHNICAL GUIDELINES FOR HERMETICALLY SEALED LITHIUM CELLS (CONT)

from storage, divided into two lots of 5 each and tested in accordance with the HT and LT tests given in SCS-459 for each type battery. The battery shall meet all the electrical and physical requirements of that specification.

Safety Tests

The remaining fifteen batteries of each type will be divided into 3 groups of 5 each and tested in the following manner at room temperature.

Reverse Discharge Test

Five (5) batteries of each type shall be tested in the manner prescribed in para 4.6. Each battery shall comply with the conditions of para 3.2.

High Rate Discharge

Five (5) batteries of each type will be tested in the manner prescribed in para 4.7. Each battery shall comply with the conditions of para 3.2.

Charging Test

The remaining five (5) batteries of each type will be tested in the manner prescribed in para 4.8. Each battery shall comply with the conditions of para 3.2.

DISTRIBUTION LIST

Defense Documentation (12) Center Attn: DDC-TCA Cameron Station (Bldg 5) Alexandria, VA 22314	Director (1) US Army Material Systems Analysis Activity Attn: DRXSY-MP Aberdeen Proving Ground, MD 21005
Commander (1) Naval Electronics Laboratory Center Attn: Library San Diego, CA 92152	Cdr, US Army Research (1) Office Attn: DRXRO-IP PO Box 12211 Research Triangle Park, NC 27709
Cdr, Naval Surface (1) Weapons Center White Oak Laboratory Attn: Library, Code WX-21 Silver Spring, MD 20910	Cdr, US Army Signals (1) Warfare Lab Attn: DELSW-OS Arlington Hall Station Arlington, VA 22212
Commandant, Marine (2) Corps HQ, US Marine Corps Attn: Code LMC Washington, DC 20380	Commander (1) US Army Mobility EQP Res & Dev Cmd Attn: DRXFB-R Fort Belvoir, VA 22060
Rome Air Development (1) Center Attn: Documents Library (TILD) Griffiss AFB, NY 13441	Commander US Army Electronics R&D Command Fort Monmouth, NJ 07703
HQ ESD (DRI) (1) L.G. Hanscom AFB Bedford, MA 01731	DELET-DD (1) DELET-DT (2) DELET-P (1) DELS-D-L (Tech Lib) (1) DELET-PB (G. DiMasi) (33)
HQDA (DAMA-ARZ-D)/ (1) Dr. F. D. Verderame) Washington, DC 20310	Commander US Army Communications R&D Command Fort Monmouth, NJ 07703
Cdr, Harry Diamond (1) Laboratories Attn: Library 2800 Powder Mill Road Adelphi, MD 20783	USMC-LNO (1)

DISTRIBUTION LIST
(Continued)

Commander
US Army Communications
& Electronics
Material Readiness
Command
Fort Monmouth, NJ 07703

DRSEL-MS-TI (2)

NASA Scientific & Tech (1)
Info Facility
Baltimore/Washington
Intl Airport
PO Box 8757, MD 21240

SUPPLEMENT TO DISTRIBUTION LIST

Other Recipients

Mr. Donald Mortel AF Aero Propulsion Lab. Attn: AFAPL-POE-1 Wright-Patterson AFB, Ohio 45433	(1)	Eagle-Picher Industries, Inc. Electronics Division Couples Department PO Box 47 Joplin, MO 64801	(1)
Mr. Richard E. Oderwald Department of the Navy Hqs., US Marine Corps Code LMC 4 Washington, DC 20380	(1)	Power Conversion, Inc. Attn: Mr. B. Jagid 70 MacQuesten Parkway South Mount Vernon, NY 10550	(1)
Commander Harry Diamond Laboratories Attn: DELHD-RDD (Mr. A. Benderly) 2800 Powder Mill Road Adelphi, MD 20783	(1)	GTE Laboratory, Inc. 40 Sylvan Road Walther, MA 02154	(1)
Union Carbide Corporation Attn: Mr. R. Powers 12900 Snow Road Parma, OH 44130	(1)		
Honeywell, Inc. Attn: Mr. T. Whittaker 104 Rock Road Horsham, PA 19044	(1)		
ESB, Inc. Ray-O-Vac Division Attn: Mr. P. Albert 212 East Washington Avenue Madison, WI 53703	(1)		