

AD-A064 591

ARMY ARMAMENT RESEARCH AND DEVELOPMENT COMMAND DOVER--ETC F/G 4/1
MODELING THE EFFECTS OF LIGHTNING ON ELECTRICAL EQUIPMENT.(U)
NOV 78 D WAXLER

UNCLASSIFIED

ARLCD-TR-78029

SBIE-AD-E400 253

NL

| OF |
AD
A064591

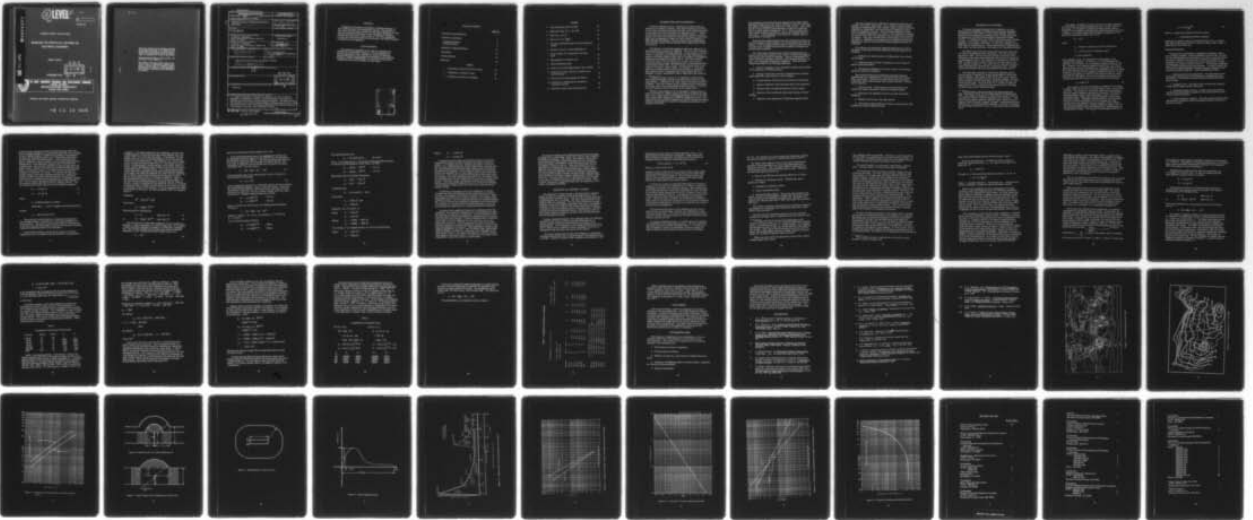

END
DATE
FILMED
4-79
DDC

ADA064591

DDC FILE COPY

② LEVEL II
NW

AD

AD-E400 253

TECHNICAL REPORT ARLCD-TR-78029

MODELING THE EFFECTS OF LIGHTNING ON
ELECTRICAL EQUIPMENT

DANIEL WAXLER

DDC
RECEIVED
FEB 14 1979
B

NOVEMBER 1978



US ARMY ARMAMENT RESEARCH AND DEVELOPMENT COMMAND
LARGE CALIBER
WEAPON SYSTEMS LABORATORY
DOVER, NEW JERSEY

APPROVED FOR PUBLIC RELEASE; DISTRIBUTION UNLIMITED.

68 12 13 056

4-2

The views, opinions, and/or findings contained in this report are those of the author(s) and should not be construed as an official Department of the Army position, policy or decision, unless so designated by other documentation.

Destroy this report when no longer needed. Do not return to the originator.

The citation in this report of the names of commercial firms or commercially available products or services does not constitute official endorsement or approval of such commercial firms, products, or services by the United States Government.

UNCLASSIFIED

SECURITY CLASSIFICATION OF THIS PAGE (When Data Entered)

| REPORT DOCUMENTATION PAGE | | READ INSTRUCTIONS BEFORE COMPLETING FORM |
|--|--|--|
| 1. REPORT NUMBER Technical Report <u>ARLCD-TR-78029</u> | 2. GOVT ACCESSION NO. | 3. RECIPIENT'S CATALOG NUMBER |
| 4. TITLE (and Subtitle) Modeling the Effects of Lightning on Electrical Equipment | 5. TYPE OF REPORT & PERIOD COVERED Final report | |
| | 6. PERFORMING ORG. REPORT NUMBER | |
| 7. AUTHOR(s) Daniel Waxler | 8. CONTRACT OR GRANT NUMBER(s) | |
| 9. PERFORMING ORGANIZATION NAME AND ADDRESS Commander, ARRADCOM Large Caliber Weapon Systems Laboratory Dover, NJ 07801 | 10. PROGRAM ELEMENT, PROJECT, TASK AREA & WORK UNIT NUMBERS 900-GH5-001 | |
| 11. CONTROLLING OFFICE NAME AND ADDRESS Commander, ARRADCOM Technical Support Directorate, DRDAR-TSS Dover, NJ 07801 | 12. REPORT DATE November 1978 | |
| | 13. NUMBER OF PAGES 54 | |
| 14. MONITORING AGENCY NAME & ADDRESS (if different from Controlling Office) SBIE | 15. SECURITY CLASS. (of this report) Unclassified | |
| 15a. DECLASSIFICATION/DOWNGRADING SCHEDULE 35p. | | |
| 16. DISTRIBUTION STATEMENT (of this Report) Approved for public release; distribution unlimited. AD-E400 253 | | |
| 17. DISTRIBUTION STATEMENT (of the abstract entered in Block 20, if different from Report) # | | |
| 18. SUPPLEMENTARY NOTES | | DDC RECEIVED FEB 14 1979 RECEIVED B |
| 19. KEY WORDS (Continue on reverse side if necessary and identify by block number) Lightning | | |
| 20. ABSTRACT (Continue on reverse side if necessary and identify by block number) A model is developed for computing the safety and reliability of electrical equipment in a lightning environment. The model specifies the parameters of lightning that are pertinent in causing damage to equipment. The report indicates how the model is to be used for testing equipment to determine failure levels. Using these failure levels, it also shows how to compute the actual safety and reliability to be expected in field use, where lightning is a threat. | | |

DD FORM 1 JAN 73 1473

EDITION OF 1 NOV 65 IS OBSOLETE

UNCLASSIFIED

SECURITY CLASSIFICATION OF THIS PAGE (When Data Entered)

410163

12 13 056 AB

FOREWORD

Designers of equipment susceptible to lightning damage receive little guidance in evaluating that hazard. The purpose of this report is to develop a model that will enable designers to evaluate the probability of damage to their equipment by lightning. Although the title of this report refers to "electrical equipment" because the text follows electrical technology, the model developed is suitable for any equipment.

ACKNOWLEDGMENT

The model was developed by the author in managing the ARRADCOM Vulnerability Program. He acknowledges the valuable assistance of Mr. Kenneth M. Kost of the Systems Vulnerability Branch of the Systems Development and Modeling Division, LCWSL, ARRADCOM, who made the mathematical computations and drew the figures in this report.

| | | |
|------------------------|--------------|-------------------------------------|
| APPROPRIATE FOR | | |
| NTIC | Wide Section | <input checked="" type="checkbox"/> |
| DDO | DOT Section | <input type="checkbox"/> |
| UNCLASSIFIED | | <input type="checkbox"/> |
| BY | | |
| DISPATCH SYMBOLS CODES | | |
| DASH SYMBOLS SPECIAL | | |
| A | | |

TABLE OF CONTENTS

| | <u>Page No.</u> |
|-------------------------------|-----------------|
| Introduction and Background | 1 |
| Incidence of Lightning | 4 |
| Damage Mechanisms | 6 |
| Striking Distance | 8 |
| Modeling of Lightning Flashes | 14 |
| Conclusions | 29 |
| Recommendations | 29 |
| References | 30 |

TABLES

| | | |
|---|--|----|
| 1 | Computation of hazard for 20-kA stroke | 23 |
| 2 | Computation of attractive areas | 26 |
| 3 | Computation of strikes to a building | 28 |

FIGURES

| | | |
|----|---|----|
| 1 | World Isokeraunic Map (for 1956) | 33 |
| 2 | Isokeraunic Map of U.S. (for 1956) | 34 |
| 3 | Plots of $\sigma_y = c(T_y)^b$ | 35 |
| 4 | Plot of $p = 0.1 [1 + (\frac{\lambda}{30})^2]$ | 36 |
| 5 | Variation of striking distance with peak lightning current | 37 |
| 6 | Protective zone of a vertical lightning rod | 38 |
| 7 | Detail of figure 6 for computation of R when $D_2 > H$ | 38 |
| 8 | Representation of attractive area | 39 |
| 9 | Typical lightning stroke | 40 |
| 10 | Model of worst-case lightning flash (due to NASA) | 41 |
| 11 | Distribution of peak currents for negative and positive strokes | 42 |
| 12 | Distribution of action integrals for flashes | 43 |
| 13 | Distribution of amplitudes and durations of continuing currents | 44 |
| 14 | Variation of hazard rate with hazard level | 45 |

INTRODUCTION AND BACKGROUND

From the beginning of time, lightning has caused death and destruction to humans, animals, man-made structures, and trees. As man first harnessed electricity and later made himself airborne, he has opened new and novel paths for lightning's havoc.¹ Today, electronics means semiconductors and digital circuitry; semiconductors with their low threshold of damage and digital circuits with their high susceptibility to noise are easy victims of lightning.² With aircraft and missiles, man gets closer to the thunderclouds that store the massive energy that generates lightning and invites new hazards.

The designer of electrical equipment gets only vague and confusing guidance on coping with lightning. There is much literature, but it is not suitable to design engineers. It may appear to the newcomer to represent much original work, but when scrutinized, it proves to be based largely on the work of a handful of investigators, beginning with Benjamin Franklin (ref 5). The most intensive modern data have been accumulated by K. Berger, who has been recording lightning strokes photographically and oscillographically in Switzerland since 1950. Berger's work is summarized in reference 6; his latest "status report," in reference 7. Important American measurements are described by Uman in reference 8. The earliest modern recordings were made in South Africa by Shonland, Collens, and Malan in 1934 to 1963 (ref 9-13); while the

¹Property damage in the U.S. is estimated at \$100 million, while about 600 people are killed and 1500 others injured by lightning annually. Lightning is the major cause of accidental losses of livestock. The most common harm by lightning is the interruption of electric power when transmission towers are struck. The dire July 1977 blackout of New York City is an example (ref 1).

²Modern semiconductors can be damaged by energy levels of a few microjoules at voltage ranges from tens to hundreds of volts. Kirk, et al, report (ref 2) a threshold of damage as low as 58 volts from human static charges for a MOSFET integrated circuit. Because of the low threshold of damage from static charges on humans, elaborate safeguards are required in handling semiconductor components (ref 3 and 4).

first significant American data were obtained at the Empire State Building by McEachron from 1939 to 1944 (ref 14 and 15), with later data added by Hagenguth and Anderson in 1952 (ref 16). Only in the past few years have there been attempts to reduce the empirical data to a model useful to designers. E. T. Pierce's work is the most notable of these attempts; he outlines his modeling efforts in reference 8. Also significant is the work of J. Phillipot which is summarized in reference 17.

Most of those modeling efforts have been directed to the use of aircraft designers whose problems are too specialized for other designers. It is the purpose of this report to avoid the airborne problem and derive a simple model that will be useful to designers of ground-based equipment.

The model must recognize that modern technology does not permit a theoretical analysis of how a piece of electrical equipment will respond when struck by lightning. Theory is inadequate, because a number of problems raised by such analysis have been, at best, only marginally examined by engineers. These problems require knowledge of the following properties:

1. Electric impedance of the mechanical housing and structure of the equipment at lightning spectra.
2. Damage criteria for electrical components and materials under high level, short duration, electric pulses.
3. Arcing behavior of electrical and mechanical components.
4. Ignition properties of the materials used in the equipment.
5. Induction effect of lightning fields on electric wiring.
6. Behavior of the mechanical parts under intense localized heating.
7. Response of the equipment to deforming magnetic fields.

The above properties are difficult to measure because they are complex, non-linear, and erratic. As a result, we must by-pass attempts at measuring them and, instead, require that the electrical equipment be subjected to real-world levels of lightning to determine the threshold of damage. This threshold defines the lowest level of lightning flash that is of concern. The model then computes the annual rate at which the equipment will be struck by such a level or greater. This rate of strike will be interpreted by the model as the safety or reliability of the equipment in a lightning environment, depending on whether the threshold of damage applies to safety or reliability.

The problem of modeling the lightning phenomenon for use by designers of laboratory and field-deployed electrical equipment is threefold:

1. Modeling the characteristics of lightning that cause equipment damage.
2. Reducing empirical data on lightning to a form usable to obtain model parameters.
3. Developing techniques for using the model in determining equipment safety and reliability.

The scientific literature traditionally describes lightning quantitatively by two parameters, time and current (and, derivatively, by charge). These are the parameters that are directly measurable and to which damage can be easily ascribed. Damage can be caused by:

1. Thermal shock. High localized current-heating at the strike point causes mechanical shock and resultant damage.
2. Burning by the lightning current on its path through the equipment.
3. Magnetic forces due to the high current.
4. Destructive current induced in electric circuits by the field radiated by a distant lightning stroke.

INCIDENCE OF LIGHTNING

To assess the potential damage due to lightning, we must determine the probability of lightning occurring near equipment and the severity of its effects. The common statistic regularly gathered for the frequency of lightning is the "thunderstorm-day" as reported by the World Meteorological Organization (WMO) (ref 18). A "thunderstorm-day" (TD) is a day during which thunder is heard. It is hardly a measure of the duration or intensity of lightning, or the number of strokes, or even of the distance of the flash from the listening point. Other observations of lightning have been made, and they have been correlated to the "thunderstorm-day".

The WMO collects TD data world-wide from local meteorological offices and publishes them extensively. The last collection was done in 1956. The most concise format for the data is the isokeraunic map which plots isokeraunic lines (levels of equal TD) for geographical areas. The world map of yearly levels of TD for 1956 (a typical year) is given in figure 1; a similar map for the U.S. appears in figure 2. The yearly TD for a specific locality is called throughout the literature the "isokeraunic level", but this report will introduce the more grammatical "keraunic level"³.

The isokeraunic map (fig 1) reveals that lightning activity varies sharply throughout the world, being highest in land areas near the equator, with a peak of 200 TD per year in the Amazon valley of Brazil and falling to zero in the polar regions. Not only is the variation over the world wide, but it is also wide over relatively small areas. The map of the U.S. in figure 2 shows the high level of 90 TD in central Florida and the low of 5 TD along the West Coast and the Canadian border.

³The literature almost universally but ungrammatically uses "isokeraunic level" for the annual number of thunderstorm days. Such usage is equivalent to calling the barometric level at a locality the "isobar" and the temperature the "isotherm". The term in this instance should be "keraunic level" which is only obtained by back formation, because "keraunic" surprisingly has not made its way yet into the English language. The author will ignore the wide usage and take the liberty of introducing this new English word.

The number of flashes in a given area are obviously related to its TD number, but empirical data show that it is not a linear relationship. The frequency of flashes increases rapidly with increased TD's, because in high lightning areas the duration of storms is longer. The relationship widely accepted and apparently first used by Westinghouse workers (ref 19), is

$$\sigma_y = cT_y^b \quad (1)$$

where

σ_y = number of flashes per km² of ground area

T_y = TD per year (or "keraunic level")

c, b are constants

The constants b and c are reported at various values, with Japanese data yielding c = 0.02 and b = 1.7 and European data yielding c = 0.007 and b = 2, according to Cianos and Pierce (ref 20). Actually, over realistic keraunic levels of 5 to 100, the results from the two sets of constants are comparable and at levels of 33 (about that for the New York City metropolitan area) are equal. Equation 1 for both sets of constants is plotted in figure 3. Since, in assessing hazards, we will be more concerned with the levels above 33, we will adopt a worst-case viewpoint and use the relationship that gives the larger σ_y for such levels, the European,

$$\sigma_y = 0.007 T_y^2 \quad (2)$$

The σ_y factor includes cloud flashes in addition to discharges to earth. Since we are only concerned with the latter, we must separate them. The division of σ_y between cloud and ground flashes has been found to depend on geographical features. Mountainous and high latitude regions experience higher ratios of ground to cloud discharges, while areas of higher keraunic levels tend to have lower ratios. Available measurements are not exhaustive, so there is no firm agreement on how to compute the ratio. Among the various relations that are proposed, that by Pierce (ref 20) will be adopted here because it gives the higher ratios for the more hazardous areas of the United States, and because it is comparatively simple. The formula recommended by Pierce is:

$$p = 0.1 \left[1 + \left(\frac{\lambda}{30} \right)^2 \right] \quad (3)$$

where p = proportion of flashes that go to ground

λ = geographical latitude in degrees

Equation 3 is plotted in figure 4 showing that the ratio, p, ranges from 10% at the equator to 60% in northern Alaska, with a value of about 30% for New York City.

Damage Mechanisms

To assess the vulnerability of equipment to lightning, laboratory testing is essential. Natural lightning cannot be used because it is too unpredictable and hazardous for any sort of controlled tests. Theoretical analysis of how any item of electrical equipment will respond to a direct or remote stroke is also impractical, because the equipment cannot be modeled properly. To model the equipment would require characterizing the properties. The high currents and rise times of lightning strokes introduce damage mechanisms that cannot be precisely predicted. These mechanisms include:

1. Burning and thermal evaporation - The high peak current and its short duration can cause localized or extensive burning. If localized, it can lead to mechanical shock and extensive structural damage.
2. Magnetic force - The high current can generate magnetic forces that rip apart metallic structures.
3. Damaging electric current - People can be electrocuted and electrical components damaged by even a small portion of the primary lightning current.
4. Electromagnetic induction - The high electromagnetic fields generated by a stroke can induce damaging secondary currents in electric circuitry.

Even after examining equipment damaged by lightning, it is frequently difficult to decide which of the mechanisms was the cause. As a result, data on the relative frequency of the four mechanisms are lacking. The only one of the four that has been widely investigated is the third, damaging electric current. The range of currents of concern spans eleven orders of magnitude. Modern transistors⁴ can be destroyed by microamperes, people killed by tens of milliamperes, electric wiring burned up by hundreds of amperes, buildings and trees destroyed by tens of thousands of amperes, and forests ignited by hundreds of thousands of amperes.

To simulate natural lightning in the laboratory, we must indicate the parameters of lightning that determine its harmfulness. It is unreasonable to attempt to require a simulator that would be capable of varying its output over the gamut of all the parameters.

Identification of these parameters is not straightforward. There is wide agreement that peak current and rate of rise are significant, but other characteristics of the lightning pulse are held in varying regard. In earlier literature, the total charge was widely used as a measure of the destructiveness of a lightning stroke. The author suspects that this deduced quantity was largely used because it was a convenient measure of the complex current-time pulse, being given by the area under the current-time waveform, or,

⁴Metal-oxide semiconductors are the most sensitive of modern transistors because of the use of a thin insulator, silicon dioxide, between the metal "gate" and the semiconductor material which acts as the "source" and the "drain". The gate, source, and drain are "brought out" of the transistor by external leads where they can be exposed to spurious and stray sources of electric energy capable of breaking down the insulator. The thickness of the metal oxide insulator, of the order of 0.1 nm, controls the upper frequency limit so that, as higher response rates are sought, this layer is being thinned down causing dielectric breakdown to occur at lower voltage and power levels. As noted, a triboelectric charge on a human at a level as low as 58 volts and a few microjoules of energy has destroyed a MOSFET integrated circuit.

$$q = \int I dt \quad (4)$$

where:

q = charge

I = current

t = time

It is, however, not a good measure of destructiveness. Recently a newly deduced quantity has been used in the literature which appears as a good indicator of destruction; it is called the "action integral" and is given by

$$\text{action integral} = \int I^2 dt. \quad (5)$$

This integral is significant, because it is a measure of two distinct damage mechanisms, (1) heating, since Joule energy is $\int I^2 R dt$ and, (2) mechanical deformation due to magnetic forces, since the attractive force between two planar conductors carrying the same current, I, is directly proportional to I^2 . A metallic structure struck by lightning can be viewed as a number of such conductors which cause the structure to experience a sudden and violent compressive force which peaks at its center. Hence the "action integral" is directly related to the compressive impulse due to the magnetic force experienced by a conducting structure struck by lightning.

Striking Distance

In computing the probability of a direct stroke to electrical equipment, the striking distance becomes an important parameter. Most of the analysis of this distance is theoretical as actual observations are difficult.

Striking distance has been theoretically analyzed by Golde (ref 21) and his results have been adapted in figure 5, which relates the striking distance to the peak lightning current. Golde's relationships are probably not universally applicable to all grounded structures, for as Franklin wisely observed (ref 5): "The distance

at which a body charged with this fluid will discharge itself suddenly, striking through the air into another body that is not charged, or not so highly charged, is different according to the quantity of the fluid, the dimensions and the form of the bodies themselves, and the state of the air between them". Golde's analysis uses typical conditions so that it probably could be elaborated profitably. Unfortunately, such elaboration requires more knowledge than available now on the electric breakdown of long air gaps under impulsive fields. Figure 5 does take into account "the quantity of the fluid" in an indirect manner: it is based on peak current which is related to the quantity, the charge. The curves show that the striking distance increases with peak current and is greater for positive strokes since the breakdown potential for a positively charged rod to a ground plane is less than for a negatively charged one. (For a long air gap, the breakdown field is about 300 kV/m for a positive charge and 500 kV/m for a negative charge.) The two curves can be closely described by the following equations:

$$D_- = 3.8 i_p^{0.75} \quad (6)$$

$$D_+ = 4.9 i_p^{0.78} \quad (7)$$

where

D = striking distance in meters

Subscripts -, + refer to negative and positive polarity

strokes

i_p = peak current in kA.

The protective zone afforded by a lightning rod depends on this striking distance; the greater it is, the more extensive the area protected. The concern of this report with the lightning rod is not due to its protective ability, but to its allowing us to estimate roughly the lightning strokes to any structure.

Using Golde's analysis, the protective zone of a vertical lightning rod can be computed from the geometric representation

in figure 6. The figure illustrates two conditions, one where the striking distance is less than the height of the lightning rod, and another where it is more than the height. In the figure, H is the height of the rod, D_1 is the striking distance if it is less than H, and D_2 if it is greater than H. The protective zone can be thought of as a cylinder of radius R about the rod. Any stroke of an amplitude corresponding to striking distance D will either strike the rod or ground depending on which of the two the leader arrives at a distance D from. For the case $D_1 < H$, a stroke whose leader comes within the horizontally cross-hatched hemisphere depicted in the figure will strike the lightning rod, while one that penetrates the vertically cross-hatched volume will be attracted to earth. Hence, the protective zone is a cylinder of radius D_1 , while at the ground the protective zone is a circle of the same radius. In the case where the striking distance is greater than the height of the rod, a stroke of distance D_2 will strike the rod only if it reaches a spherical sector of radius D_2 (centered at the top of the rod) down to a distance of D_2 from the ground. To aid in computing the radius of protection for this case, the following sketch (fig 7) is a detail of figure 6.

Therefore,

$$R^2 + (D_2 - H)^2 = D_2^2$$

from which

$$R = (2D_2H - H^2)^{1/2}$$

Summarizing the computations:

$$R = D \quad \text{where } D_1 < H \quad (8)$$

or
$$R = (2D_2H - H^2)^{1/2} \quad \text{where } D_2 > H \quad (9)$$

We can think of our vulnerable equipment, be it a missile on a launcher, a radio transmitter, an electric power line, or a building in which electrical apparatus is housed, as acting like a lightning rod. We can then consider the attractive area of our vulnerable equipment, if it is of dimensions much smaller than R, as

$$A = \pi R^2 \quad (10)$$

where R is derived from either equation (8) or (9).

If the projected ground area of our equipment of concern can be described as being of length (L) and width (W) we can represent the attractive area as in figure 8. The area comprises four quarters of a circle of radius (R), two rectangles of side (L) and (R), two rectangles of sides (W) and (R) and the area covered by the equipment itself, LW . The area then is:

$$A = LW + 2R(L + W) + \pi R^2 \quad (11)$$

If the vulnerable area can be described as a circle of radius (r), the attractive area becomes:

$$A = \pi (r + R)^2 \quad (12)$$

Let us compute the attractive or vulnerable areas of several structures, the world's tallest building, a man, a tree and a house. Each tower of the World Trade Center in New York City is 413 meters tall and 64 meters on each side. For an "average" stroke of 20 kA, equations 6 and 7 indicate striking distances as follows:

$$\begin{aligned} D_- &= 3.8 (20)^{0.75} &= 35.9 \text{ m} \\ D_+ &= 4.9 (20)^{0.78} &= 50.6 \text{ m} \end{aligned}$$

Since D_- and D_+ are less than H , the building attracts lightning in an area

$$A = LW + 2R(L + W) + \pi R^2$$

where $R = D$ and $L = W = 64$ m, from which $A_- \approx 1.7 \text{ km}^2$ and $A_+ \approx 2.5 \text{ km}^2$.

For an extreme stroke of 200 kA,

$$\begin{aligned} D_- &= 3.8 (200)^{0.75} &= 202 \text{ m} \\ D_+ &= 4.9 (200)^{0.78} &= 305 \text{ m} \end{aligned}$$

D is still less than H and

$$A_- = 18.4 \text{ km}^2 \text{ and } A_+ = 37.4 \text{ km}^2$$

For a 1.8-m tall man, $D > H$ for both a 20-kA and 200-kA stroke, so that we must use equation 9 from which, for 20kA,

$$R_- = (2D_H - H^2)^{1/2} = 11.2 \text{ m}$$

$$R_+ = (2D_H + H^2)^{1/2} = 13.4 \text{ m}$$

Ignoring the man's horizontal dimensions,

$$A_- = \pi R_-^2 = 394 \text{ m}^2$$

$$A_+ = \pi R_+^2 = 564 \text{ m}^2$$

At 200-kA level,

$$R_- = 27 \text{ m and } R_+ = 33 \text{ m}$$

from which,

$$A_- = 2274 \text{ m}^2, \text{ and}$$

$$A_+ = 3439 \text{ m}^2$$

Similarly, for a 5-m tree, at

$$20 \text{ kA, } A_- = 1049 \text{ m}^2$$

$$A_+ = 1511 \text{ m}^2$$

$$200 \text{ kA, } A_- = \pi(1995) = 6267 \text{ m}^2$$

$$A_+ = \pi(3025) = 9503 \text{ m}^2$$

For a house, 6 m in height and $15 \times 11 \frac{1}{2}$ m in cross-section,

$$20 \text{ kA, } A_- = 2471 \text{ m}^2$$

$$A_+ = 3228 \text{ m}^2$$

$$200 \text{ kA}, \quad A_- = 10,275 \text{ m}^2$$

$$A_+ = 14,748 \text{ m}^2$$

Computing the vulnerable and attracting areas for electrical equipment (or people) in actual situations is usually not direct or simple. As Franklin observes, lightning may strike a structure that is poorly grounded and then jump to other better grounded ones. We read continually of people who seek shelter under trees being electrocuted by lightning. Those people obviously were not struck directly but sustained one (or more likely, part of one) stroke that hit the tree. Such cases reveal that the hazard to the people cannot be computed from their individual attractive areas, but rather from the attractive areas of the "sheltering" trees or even of larger trees nearby. Similarly, people and equipment inside struck buildings that are poorly grounded frequently are hurt, because the lightning, in its seemingly erratic search for earth, arcs to the people and electric wiring.

In assigning an attractive area to any equipment we should consider the trees and buildings nearby and the degree of protection and, concomitantly, the degree of hazard, they afford. Equipment inside a structure that is fully protected, in accordance with Franklin's advice, can be considered immune from lightning damage. But, if the protection was improperly designed or has deteriorated, for example, by corrosion of the earthing terminals of a rod, the hazard would be greater than if no protection had been attempted.

To obtain easily applied procedures for computing safety and reliability, this report will hypothesize the surroundings that affect the lightning susceptibility of equipment. The surroundings will be based on what is thought reasonable for equipment that is not properly protected from a stroke. It will be assumed that the attractive area is due to a poorly designed 20-meter structure close to the equipment of concern. The structure may be a poorly protected six-story building in which the equipment is used or a tall tree near which the equipment is emplaced. This hypothetical setting is also roughly equivalent to two trees, each 10 meters high, spaced about twice the radius of protection, regardless of the magnitude of the peak stroke current. The radius of protection, in itself, however, does depend on the peak current. For this case, the radius can be considered to range from about 20 to 100 meters.

The above simulation of the lightning-concerned surroundings is thought to be a reasonable "worst-case" and so will be used for simplified calculations. The report, nevertheless, will provide the procedures for determining attracting zones for situations where the heights and numbers of structures associated with the susceptible victims are known. These procedures will only be applicable to computing the rate of strokes to structures up to about 50 meters tall because beyond that height, upward leaders and hence triggered lightning, become increasingly significant. As such height increases, keraunic levels become of questionable value because the structure triggers lightning that normally would not occur. The word "structure" is applied loosely here because it can refer to Franklin's kite and to the Apollo 12 rocket. Both of those "structures" triggered strokes that are significant in the annals of lightning technology.

MODELING OF LIGHTNING FLASHES

The importance of peak current in characterizing a lightning stroke not only as a measure of destructiveness but also of the striking distance has been noted. It is the most common parameter in specifying the size of a stroke. But other characteristics of the lightning flash are important. The rise time determines the high frequency extent of the lightning spectrum and, hence, the lightning response of electric circuits; it also affects dielectric breakdown in insulators and semiconductors and, most importantly, critically controls the design of protective devices. Such devices must act fast enough to keep the lightning currents from the equipment that they are designed to protect.

Another important measure of the lightning flash is its duration, inasmuch as the energy content is strongly determined by it. Heating damage is directly proportional to the duration of the lightning pulse. Also important are the strokes following the initial one in a flash; they are usually of lower magnitude, but some investigators claim that their rise times can be shorter.

The action integral has recently been adopted as a significant lightning characteristic and is a good measure of the destructiveness of a flash. Charge in a flash is still computed by investigators, and

although it has given way to the action integral in favor, it is a good indication of the duration of the pulse. Peak current and action integral correlate well, and Pierce (ref 8) has found the following rough but valuable relationship between them:

$$\text{Action integral} \cong 5 \times 10^{-5} i_p^2 \quad (13)$$

where i_p = peak current in kA.

Charge, however, does not seem to relate to peak current except during the impulsive phase of a stroke, that is, the initial steep rise and fall, as shown in figure 9. This reveals that the total charge is mostly determined by the duration of the flash rather than by the comparatively short peak current.

A worst-case model of a lightning flash should not attempt to maximize the severity of all parameters, but rather to represent a plausible waveshape that maximizes damage. Many models have been proposed and used. This report will adopt one used by NASA for its space shuttle specifications (ref 22) because of its reasonableness and simplicity (fig 10). A simplicity that is readily noted is the straight line connection between maximum and minimum points. Of course this is artificial, but in laboratory simulators there would be considerable variations from even natural transitions so that this simplification is attractive as a model for use in specifications and in computation.

Two important parameters of the lightning current, time to peak and size of intermediate currents, are independent of each other and of peak value. The action integral and charge are determined by current waveshape with some correlation between action integral and peak current.

In modeling lightning strokes, we should examine the statistical distribution of the important parameters. We have mentioned that peak current is the basic parameter that is used in the literature to identify a stroke; its distribution is shown in figure 11 which is based on data reduction by Pierce (ref 8) and Phillipot

(ref 17). The statistics for action integral and continuing currents are plotted in figures 12 and 16, as derived by Pierce (ref 8).⁵

The NASA model appears to be a worst-case model based on selecting critical parameters at levels representing about the highest or lowest 2%. Thus, the peak of 200 kA implies that 2% of all lightning strokes have that initial peak or more. Similarly, the other parameters selected are:

1. Rate of rise (2% have the indicated 100 kA/ μ s or faster).
2. Duration of continuing current. (2% have the chosen duration or longer).
3. Amplitude of continuing current.
4. Peak of subsequent stroke.
5. Interval between strokes. This is the only variable in the model, leaving it to the designer to decide what interval is worst-case (or what his test equipment is capable of). About 2% of all flashes have intervals less than 17 msec and another 2% more than 230 msec.

The number of strokes selected seems to be based on engineering judgment as to sufficiency for destructive effect and to capability of test generators.⁶

Not only have the individual parameters of the model been selected in accordance with a consistent worst-case criterion, but

⁵"Probits" used by the commercial graph paper as the abscissa, bottom of figure 12, is a measure introduced by statisticians. It is defined as $\text{probit} = 5 + \text{normal deviate}$. For example, the 50% abscissa which is the zero normal deviate is then equal to five probits. This report will not use this term but the more familiar "percentage greater than the ordinate" shown at the top of figure 12, on which the abscissa lines are based.

⁶There are only a few such generators in use in this country, probably about half a dozen.

the complete model is reasonable. Moreover, it is being actively used by NASA in evaluating parts of its space shuttle systems. It is, therefore, selected for this report over many other proposed models (including one used by the author in his work).⁷

The model should be recognized as representing a negative flash. Positive flashes are described by other waveshapes.

The description and occurrence of positive flashes are supported by little data. It is well agreed among investigators that such flashes are of higher peak and longer duration strokes than negative flashes. Most of the data available were obtained by Berger on Mount San Salvatore in Switzerland (ref 6) (the fountain-head of most lightning statistics) where conditions are not typical. The tower for the lightning observatory there is 915 meters above sea level and 640 meters above nearby Lake Lugano. Other investigators have concluded that the higher the height of observation the larger the ratio of positive to negative strokes. Moreover, as we described earlier, the taller a structure the greater is the frequency of upward leaders and hence of triggered strokes. The available description of positive strokes is questionable as to its typicalness. Since it appears their frequency is below 10% for most terrain where electrical equipment is installed and the worst-case model adopted here is sufficiently pessimistic, this report will not attempt to model positive flashes. This restriction will help simplify the procedures being developed herein to estimate safety and reliability in a lightning environment.

We have developed mathematical descriptions of the character and occurrence of lightning which are now adequate for computing the hazard rate for electrical equipment in such an environment. The first piece of data is the keraunic level or the number of thunderstorm-days per year, T_y , for the locale in which the equipment is to be used. If the equipment may be employed in an area that subtends different keraunic levels, as would occur commonly, we should use the highest T_y that applies; or, if we choose, we can compute the safety and reliability for whatever localized areas we are concerned with. The value of T_y is obtained from the isokeraunic

⁷Other models in use or proposed vary in rise time, peak, duration, number of strokes, etc.

maps of the United States and the world in figures 1 and 2.

From the keraunic level, we obtain the yearly number of flashes per square kilometer, σ_y , by means of the empiric relation (eq 2):

$$\sigma_y = 0.007 T_y^2$$

The part of σ_y that represents flashes to ground, p , is (eq 3):

$$p = 0.1 \left[1 + \left(\frac{\lambda}{30} \right)^2 \right]$$

where λ = latitude in degrees. The product, $p\sigma_y$, represents the number of flashes to ground per square kilometer annually.

Basic to the computation is the establishment of the peak currents at which the equipment fails, for reliability prediction, and at which the equipment becomes unsafe, for safety prediction. These values are obtained by applying current waveshape scaled-down from the worst-case model (fig 10) to the external parts of the equipment that are likely points of a lightning strike. For a missile, any point on the external surface may be struck in flight whereas on the launcher, exposed surfaces and connecting cables may be struck. For a radio or radar, the antenna is usually elevated so far above the receiver and transmitter that it acts as a lightning rod and so is the only part that probably will be struck.

The investigation must determine what constitutes a reliability failure and what constitutes a safety failure. Reliability is usually the easier of the two to characterize for a piece of equipment; as a minimum, a reliability failure is one where a lightning stroke damages one or more components so that the equipment can no longer perform as required. However, in some equipment, especially where digital circuits are used, a failure may be defined as the upsetting of the output information or of the memory even though there may be no physical damage. Safety may also have different levels of definition; essentially, it pertains to a hazard to people, but determining what is hazardous with a piece of equipment may not be straightforward. At a rather low level there may be electric leakage at manual controls that shock human operators, at higher levels there may be arcing that ignites inflammable

materials or vapors, and at still higher levels, magnetic forces may explode the equipment. The safety and reliability investigator must analyze the design of the equipment, its performance, how it is used, failure modes, personal hazards, etc., to arrive at what constitutes failures that pertain to reliability and those that pertain to safety. His decision as to the equipment failures that are reliability and safety related may not be reached easily. That decision may be argued by other workers. At times, it may be appropriate to set up different levels of safety and reliability, graded as to their seriousness.

The current applied is increased (by scaling up) until it reaches the levels at which the equipment loses its reliability and safety. These levels are then used to determine the probabilities of failure and of safety hazard.

Other parameters such as time to peak magnitude of intermediate currents do not correlate with peak value. We should scale those other parameters as we scale down from peak when testing for failures and hazards. The action integral is a strong measure of destructiveness and a big contributor to it is the continuing current after the initial impulse. Both of these parameters should be scaled, as well as arbitrarily worst-casing the rate of rise. The fixing of the rate of rise to that of the NASA model, 100 kA per μ s, is thought to be a reasonable simplification.

The scaling down should be done statistically, to maintain a reasonable and manageable lightning model. To determine the response to a lightning flash of peak current of 50 kA, for example, first the frequency of occurrence of such an initial stroke must be determined. From figure 11 we see that 25% of all strokes have such a value or higher. Such a frequency of occurrence has an action integral of $7 \times 10^4 \text{ A}^2\text{s}$, figure 12, and a continuing current of 225-A magnitude and 225-s duration, figure 13. The second stroke is arbitrarily scaled down by direct arithmetic ratio so that, with point B scaled down

$$\frac{50 \text{ kA}}{200 \text{ kA}} \text{ or } 1/4, \quad \text{H will be}$$

scaled down to $\frac{50}{4}$ or 12 kA, with points J and K remaining

at the same level as E, F and G, or 225 A. Points C, D and I and

the timing of G and K should be adjusted to obtain an action integral of $7 \times 10^4 \text{ A}^2\text{s}$. Regardless of the damage mechanism, if the scaled-down model represents the threshold of damage to the equipment, 25% of all flashes to earth will damage it.

Fundamental to using keraunic data is the attractive area. To compute the attractive area, we need the striking distance which depends on peak current, as follows:

$$D_- = 3.8 i_p^{0.75}$$

$$D_+ = 4.9 i_p^{0.78}$$

If the target of concern to a lightning strike represents a comparatively small physical area on the ground, the radius of the attractive area is obtained from:

$$R = D_1 \quad \text{where } D_1 < H$$

or
$$R = (2D_2 H - H^2)^{1/2} \quad \text{where } D_2 > H$$

If the target extends over a large physical area, the attractive area is:

$$A = LW + 2R(L + W) + \pi R^2$$

The number of lightning strikes to a point or an area can then be computed by multiplying the number of ground flashes/ km^2/yr , p_{gy} , by the area of attraction, A . A increases with peak current, i_p , so that a vulnerable area (i.e., one with a tall conductive structure) will experience a larger number of large strokes than distribution data imply. The safety and reliability investigator must measure, in laboratory tests, the peak currents that represent the threshold of impairment. Using such a value of current, he can then compute the number of flashes exceeding that threshold that will strike the area of concern annually. The number of flashes is the hazard rate. We will designate the annual rates for flashes exceeding the reliability threshold, h_r , and for those exceeding the safety threshold, h_s .

The computation can best be explained by examples. Examples of increasing complexity which should fully illustrate the method will be used.

For our initial example, a designer has shown that his equipment is safe when subjected to the worst-case model of figure 10. How safe is it? The equipment is to be used anywhere in the U.S. and is used outdoors without any specific lightning protection. The highest keraunic level in the U.S. is 90 (in central Florida), or, in other words, in that region, on the average, there are 90 days a year when lightning occurs. Using equation 2:

$$\sigma_y = 0.007 T_y^2$$

we compute the incidence of lightning, as follows:

$$\begin{aligned}\sigma_y &= 0.007 (90)^2 \\ &= 57 \text{ flashes/km}^2/\text{year}.\end{aligned}$$

The number of these flashes that go to ground is given by equation 3:

$p = 0.1 [1 + (\frac{\lambda}{30})^2]$, where $\lambda = 30$, the latitude in degrees in central Florida.

$$p = 0.1 [1 + (\frac{30}{30})^2] = 0.2$$

so that $p\sigma_y = 57 (0.2) = 11.4$ ground flashes/ km^2/year . To compute the striking distance of a 200-kA negative stroke we use equation 6:

$$\begin{aligned}D_- &= 3.8 i_p^{0.75} \\ &= 3.8 (200)^{0.75} = 202 \text{ meters}\end{aligned}$$

For positive strokes, from equation 7:

$$D_+ = 4.9 (200)^{0.78} = 305 \text{ meters}$$

Using the effective height criterion of 20 meters adopted earlier, we compute the attractive radius from equation 9:

$$R = (2DH - H^2)^{1/2} \quad \text{since } D \geq H$$

$$R_- = (2 \times 202 \times 20 - \frac{20^2}{20})^{1/2} = (7680)^{1/2} = 88 \text{ m}$$

The area of attraction is, from equation 10:

$$A_- = \pi R^2 = (7680) = 24,127 \text{ m}^2$$

$$= .024 \text{ km}^2 \text{ for negative flashes.}$$

For positive strokes,

$$R_+ = (2 \times 305 \times 20 - \frac{20^2}{20})^{1/2} = (11,800)^{1/2} = 108 \text{ m}$$

$$A_+ = \pi (11,800) = 37,070 \text{ m}^2 = .037 \text{ km}^2$$

Assuming that 10% of the ground flashes are positive, there will be (11.4) (0.1) = 1.1 positive flashes/km²/year and 10.3 negative. From figure 11, 2.5% of the negative and 8% of the positive exceed 200 kA. Therefore, the equipment will be unsafe at a rate of

$$h_s = (10.3) (0.025) (.024) + (1.1) (0.08) (.037)$$

$$= 9.44 \times 10^{-3} \text{ failure/year.}$$

The probability that the equipment will be unsafe in a lightning storm is 9.44×10^{-3} in a year of exposure, or the equipment will be unsafe once in $\frac{1}{9.44 \times 10^{-3}}$ or in 106 years. The same

equipment in the New York City area where TD = 30 and $\lambda = 41$:

$$\sigma_y = 0.007(30)^2 = 6.3 \text{ flashes/km}^2/\text{year.}$$

$$p = 0.1 \left[1 + \left(\frac{41}{30} \right)^2 \right] = .29$$

$$p\sigma_y = .29 \times 6.3 = 1.83 \text{ ground flashes/km}^2/\text{year of}$$

which 0.1 (1.83) = .18 positive and 1.65 negative.

$$h_s = (1.65) (0.025) (.024) + (.18) (0.08) (.037)$$

$$= 1.52 \times 10^{-3}$$

or the probability that the equipment will be unsafe annually because of lightning in the New York City area is 1.52×10^{-3} ; that is, it will probably experience one safety failure in $\frac{1}{1.52 \times 10^{-3}}$

or 657 years.

As another example, if the same equipment is found to be unreliable if struck by a flash of 20 kA, how unreliable is it? The reliability is the probability that the equipment will be struck by a stroke of 20 kA or greater. The computation is more involved than that for the 200-kA strokes because of the "or greater" condition. We must compute the probability for range from 20 kA through 200 kA. This is most readily done by breaking the peak-current range into intervals and evaluating each interval. Table 1 illustrates this procedure.

Table 1

Computation of hazard for 20-kA stroke

| Interval | Neg % | Pos % | A ₋ | A ₊ |
|----------|-------|-------|----------------|----------------|
| > 20 kA | 54 | 58 | -- | -- |
| 20-30 | 14 | 12 | .0039 | .0064 |
| 30-40 | 10 | 7 | .0054 | .0087 |
| 40-60 | 11 | 10 | .0075 | .012 |
| 60-100 | 9 | 11 | .011 | .0175 |
| 100-200 | 7.5 | 10 | .019 | .029 |
| > 200 | 2.5 | 8 | .024 | .037 |

Table 1 is devised as follows. The interval ">20 kA" has entries indicating that 54% of all negative strokes and 58% of all positive strokes exceed 20 kA as read from figure 11. Continuing with that figure, it is noted that 40% and 46% are the respective values for strokes exceeding 30 kA; therefore, for the interval "20-30", 54% - 40% or 14% and 58% - 46% or 12% of strokes fall between 20 and 30 kA. For this interval, compute A₋ and A₊ for

the average value of 25 kA to be .0039 and .0064 km. Similar procedures are used for the remaining entries with the "200" being identical to that used in the computation of h_s previously. Then compute h_r for each interval, starting with the 20-30 one, and add them to obtain the hazard rate for the equipment having a reliability up to 20 kA. Thus, $h_r = 10.3 [.14(.0039) + .1(.0054) + .11(.0075) + .09(.011) + .075(.019) + .025(.024)] + 1.1 [.12(.0064) + .07(.0087) + .1(.012) + .11(.0175) + .1(.029) + .08(.037)] = .0621$.

Similarly for reliability to 60 kA, $h_r = 10.3 [.09(.011) + .027(.019) + .025(.024)] + 1.1 [.11(.0175) + .1(.029) + .08(.037)]$

$$h_r = .0396$$

For 100 kA:

$$h_r = 10.3 [.075(.019) + .025(.024)] + 1.1 [.1(.029) + .08(.037)] = .0272$$

For 200 kA:

$$h_r = 10.3 [.025(.024) + 1.1 .08(.037)] = 9.44 \times 10^{-3}$$

These are the data from which the effect of increasing the threshold of hazard can be observed. They are plotted in figure 14. The curve reveals that small benefit is obtained from improving equipment installations from low levels, about 20 kA, to 100 kA. Only in raising the threshold of hazard beyond 100 kA is a big advantage derived. The reasons for this unusual behavior are that even though the frequency of flashes falls off as the magnitude of peak current goes up, the area of attraction increases too fast with peak current. Only with the rapid fall in frequency of strokes beyond 100 kA does nature start being kind to us.

If the reliability values are too low, the designer has two methods for raising them. He can harden his design so it fails at higher levels or he can reduce the attractive area of the equipment. The attractive area used in our calculation is based on an assumed effective height of 20 m, which in actuality can be much lower. In practice, the most effective technique for reducing the attracting area is to install protective devices as recommended by Franklin. When fully protected, the attractive area essentially drops to zero, however, what constitutes "full protection" is not precise. The determination of the attractive area of equipment that is less than fully protected is still beyond present technology.

Suppose that in our first example, the designer can reduce the effective height of attraction from 20 to 10 meters, as for example, by lowering the height of his radio or radar antenna, or installing his equipment in a smaller building, or not elevating the missile on its launcher. Then:

$$\begin{aligned} R_- &= (2 \times 203 \times 10 - 10^2)^{1/2} \\ &= (3960)^{1/2} = 63\text{m} \end{aligned}$$

$$\begin{aligned} R_+ &= (2 \times 301 \times 10 - 10^2)^{1/2} \\ &= (5920)^{1/2} = 77\text{m} \end{aligned}$$

$$A_- = \pi(3960) = 12440.71 \text{ m}^2 = .0124 \text{ km}^2$$

$$A_+ = \pi(5920) = 18598.2 \text{ m}^2 = .0186 \text{ km}^2$$

$$\begin{aligned} h_S &= (10.3 \times .0124) (0.025) + (1.1 \times .0186) (0.08) \\ &= 4.83 \times 10^{-3} \end{aligned}$$

Reducing the effective height 50% increased the safety by about the same amount.

To show how the effective height affects the model, the attractive areas for effective heights of 10 meters and 5 meters are computed (table 2). For the range of peak currents 20 kA and greater, D is always greater than H, so equation 9 applies to all computations.

From the data it is concluded that the attractive area for a stroke of given magnitude is roughly proportional to the effective height. This relation can be quickly deduced by examining the equation $A = \pi H [2D - H]$ which is obtained when $R = [2DH - H^2]^{1/2}$. Since $2D$ is usually at least an order of magnitude greater than H , $A \approx 2\pi DH$, where for a given i_p , D is constant; hence $A \sim H$. For simple targets of no more than about 20 meters in height, the number of flashes it will attract, or its hazard rate, is roughly proportional to its height of attraction. As the height of the lightning target increases, equation 8, $R = D$, where $D < H$, becomes applicable, so that $A = \pi D^2$. Therefore, in the case of tall targets, the attractive area for a given peak lightning is independent of its height. However, another phenomenon (that of triggered strokes) may become significant, so that we must reiterate that our complete model is only applicable to targets of up to about 50 meters in height.

Table 2

Computation of attractive areas

For H = 10 m

For H = 5 m

$$R^2 = 2DH - H^2$$

$$R = 2 \times 5 \times D - 25$$

$$= 2 \times 10 \times D - 100$$

$$= 10D - 25$$

$$= 20D - 100 = 20(D - 5)$$

$$= 10(D - 2.5)$$

$$A_- = 20 \pi [3.8 i_p^{0.75} - 5]$$

$$A_- = 10 [3.8 i_p^{0.75} - 2.5]$$

$$A_+ = 20 \pi [4.9 i_p^{0.78} - 5]$$

$$A_+ = 10 [4.9 i_p^{0.78} - 2.5]$$

| i_p | A_- | A_+ | A_- | A_+ |
|-------|---------|--------|---------|--------|
| 20 | .001944 | .00287 | .001050 | .00151 |
| 50 | .00418 | .00620 | .002166 | .00318 |
| 100 | .00724 | .0109 | .00632 | .00551 |
| 200 | .01283 | .0189 | .00619 | .00952 |

Let us now compute the highest probability of a small building (in which electrical equipment is installed, for example) being struck by a stroke greater than 20 kA. The building is about 7 meters high, 30 meters long, and 20 meters wide. The attractive area is

$$A = LW + 2R(L + W) + \pi R^2$$

The probabilities are computed as shown in table 3.

Table 3. Computation of strikes to a building.

| Interval | neg % | pos % | D ₋ | R ₋ | A ₋ | D ₊ | R ₊ | A ₊ | h x 10 ⁻³ |
|----------|-------|-------|----------------|----------------|----------------|----------------|----------------|----------------|-------------------------|
| >20 kA | 54 | 58 | | | | | | | |
| 20-30 | 14 | 12 | 42.5 | 23.4 | 660 | 60.3 | 28.2 | 5,918 | 47.73 |
| 30-40 | 10 | 7 | 54.7 | 26.8 | 536 | 78.4 | 32.4 | 7,137 | 40.23 |
| 40-60 | 11 | 10 | 71.5 | 30.9 | 690 | 103.6 | 37.4 | 8,734 | 33.98 |
| 60-100 | 9 | 11 | 101.6 | 37.1 | 8,684 | 149.5 | 45.2 | 11,538 | 26.31 |
| 100-200 | 7.5 | 10 | 162.9 | 47.2 | 12,318 | 244.1 | 58.0 | 16,968 | 16.92 |
| >200 | 2.5 | 8 | 202.1 | 52.7 | 14,595 | 305.5 | 65.0 | 20,373 | 5.55 |

$$A = LW + 2R(L+W) + \pi R^2$$

$$R = (2DH - H^2)^{\frac{1}{2}} = 14D - 49)^{\frac{1}{2}}$$

$$A = 600 + 2R(50) + \pi R^2$$

$$= 600 + 100R + \pi R^2$$

$h = 10.3$ (neg %) (A₋) + 1.1 (pos %) (A₊)
 $h = 10.3$ (0.025) (.0146) + 1.1 (.08) (.0204) = 5.55 x 10⁻³
 $h = 10.3$ (.075) (.0123) + 1.1 (.11) (.017) = 11.37 x 10⁻³
 $h = 10.3$ (0.9) (.008634) + 1.1 (.11) (.0115) = 9.39 x 10⁻³
 $h = 10.3$ (.11) (.006690) + 1.1 (.1) (.008734) = 8.54 x 10⁻³
 $h = 10.3$ (.1) (.005536) + 1.1 (.07) (.007137) = 6.25 x 10⁻³
 $h = 10.3$ (.14) (.004660) + 1.1 (.12) (.005918) = 7.50 x 10⁻³

Table 3 indicates that the probability of the building being struck in central Florida by a greater than 20 kA stroke is 4.773×10^{-2} annually or once every 21 years. From table 3, it is evident that if the stroke is increased to 30 kA, the probability drops to 4.023×10^{-2} ; and that for 40, 60, 100 and 200 kA strokes, the respective probabilities are 3.398, 2.631, 1.692 and 0.555, all $\times 10^{-2}$.

CONCLUSIONS

This report develops a model for assessing the hazards of lightning to electrical equipment. The model entails two distinct procedures, the first for measuring the level of lightning at which a hazard is produced in the equipment and the second for computing the safety and reliability from that level. The measurement is made with a simulated lightning pulse specified by the model; the model computes the annual hazard rate for the equipment at the locale at which it is employed. The hazard rate is interpreted as the safety or reliability of the equipment in accordance with whether the hazard is one to safety or reliability.

RECOMMENDATIONS

The statistics on lightning are ever expanding, so there is continued refinement in the definition of its occurrence and characteristics. The model can be improved as our knowledge enlarges in the following areas:

1. World-wide occurrence of lightning.
2. Characteristics of flashes.
3. Behavior of long arcs, particularly in defining attractive areas.
4. Frequency of lightning strikes to various targets, especially as a function of peak amplitude.
5. Damage mechanisms.

The model developed can be improved in the matter of conciseness by means of a more elegant mathematical treatment. It appears that a direct relation should be obtained between hazard rate and the independent parameters of peak hazard current and attractive areas. Such a relation would eliminate a number of steps in the present model. Another desired simplification is a more direct means for scaling down the worst-case lightning model of figure 10. One obvious means for doing that would be to work up a series of such current waveforms for the frequencies of occurrence greater than 2%, which represents the worst-case. The author hopes that he will be able to pursue those efforts in order to compress the model and so simplify its use.

REFERENCES

1. G. L. Wilson and P. Zarakas, "Anatomy of a Blackout," IEEE Spectrum, Vol 5, No. 2, Feb 78, pp 38-46.
2. W. J. Kirk, Jr., et al, Control of Electrostatic Damage to Solid State Devices, BDX-613-1080, Kansas City, MO, The Bendix Corp., Mar 74.
3. A. E. Dawe, Electrostatic (Static) Sensitive Parts, Testing, Identification, Marking, Handling and Packaging of No. M283308, Redondo Beach, CA. TRW Systems Group, 19 July 74.
4. Electrostatic Sensitive Devices, Marking and Handling Thereof, MSD 1-GEN-00075. Boston, Raytheon Corp., 20 Aug 74.
5. I. Bernard Cohen, ed. Benjamin Franklin's Experiments, Cambridge, MA, Harvard University Press, 1944.
6. K. Berger, "Novel Observations on Lightning Discharges: Results of Research on Mount San Salvatore," Journal of the Franklin Institute, Vol 283, No. 6, June 67, pp 478-525.
7. K. Berger, "Methoden und Resultate der Blitzforschung auf dem Monte San Salvatore bei Lugano in dem Jahren 1963-1971," Schweizerischer Elektrotechnischer Verein Bulletin, Vol 63, No. 24, 1972, pp 1403-1422.

8. E.T. Pierce, "Natural Lightning Parameters and Their Simulation in Laboratory Tests," Proceedings of the Lightning and Static Electricity Conference, Culham Laboratory, England, 14-17 April 1975, London, Royal Aeronautical Society.
9. B.F.J. Schonland, "The Lightning Discharge," Handbuch der Physik, Vol 22, pp 576-628, Springer-Verlag OHG, Berlin, 1956.
10. D.J. Malan, "Les de'charges dans l'air et la charge inférieure positive d'un nuage orageux," Ann: Geophys., 8: 385-401, 1952.
11. D.J. Malan, Physics of Lightning, The English Universities Press, Ltd., London, 1963.
12. D.J. Malan and H. Collens, Progressive Lightning, Pt. 3, "The Fine Structure of Lightning Return Strokes," Proc. Roy. Soc., London, A162: 175-203, 1937.
13. B.F.J. Schonland, D.J. Malan, and H. Collens, Progressive Lightning, pt. 6, Proc. Roy. Soc., London, A168: 455-469 (1936).
14. K.B. McEachron, "Lightning to the Empire State Building," J. Franklin Inst., 227: 149-217, 1939.
- 1 K.B. McEachron, "Lightning to the Empire State Building," Trans. AIEE, 60: 885-889, 1941.
16. J.W. Hagenguth and J.G. Anderson, "Lightning to the Empire State Building," pt. 3, Trans. AIEE, 71 pt. 3: 641-649, 1952.
17. J. Phillpot, "Lightning Currents in Relation to Measured Parameters of Natural Lightning," Proceedings of the Lightning and Static Electricity Conference, Culham Laboratory, England, 14-17 April 1975, London, Royal Aeronautical Society.
18. World Distribution of Thunderstorm Days, No. 21 Geneva, World Meteorological Organization, 1956.

19. E. L. Maxwell, et al, Development of a VLF Atmospheric Noise Prediction Model, Final Report, Contract N00014-69-C-0150, Boulder, CO, Westinghouse Georesearch Laboratory, 1970.
20. N. Cianos and E. T. Pierce, A Ground-Lightning Environment for Engineering Usage, Technical Report 1, Menlo Park, CA, Stanford Research Institute, August 1972.
21. R. H. Golde, Lightning Protection, London , Edward Arnold, 1973.
22. E. H. Schulte, Lightning Tests of Space Shuttle Orbiter Outer Panel Severance System, Phase I, Contract NAS9-13970, St. Louis , McDonnell Aircraft Co., 9 Sept 1976.

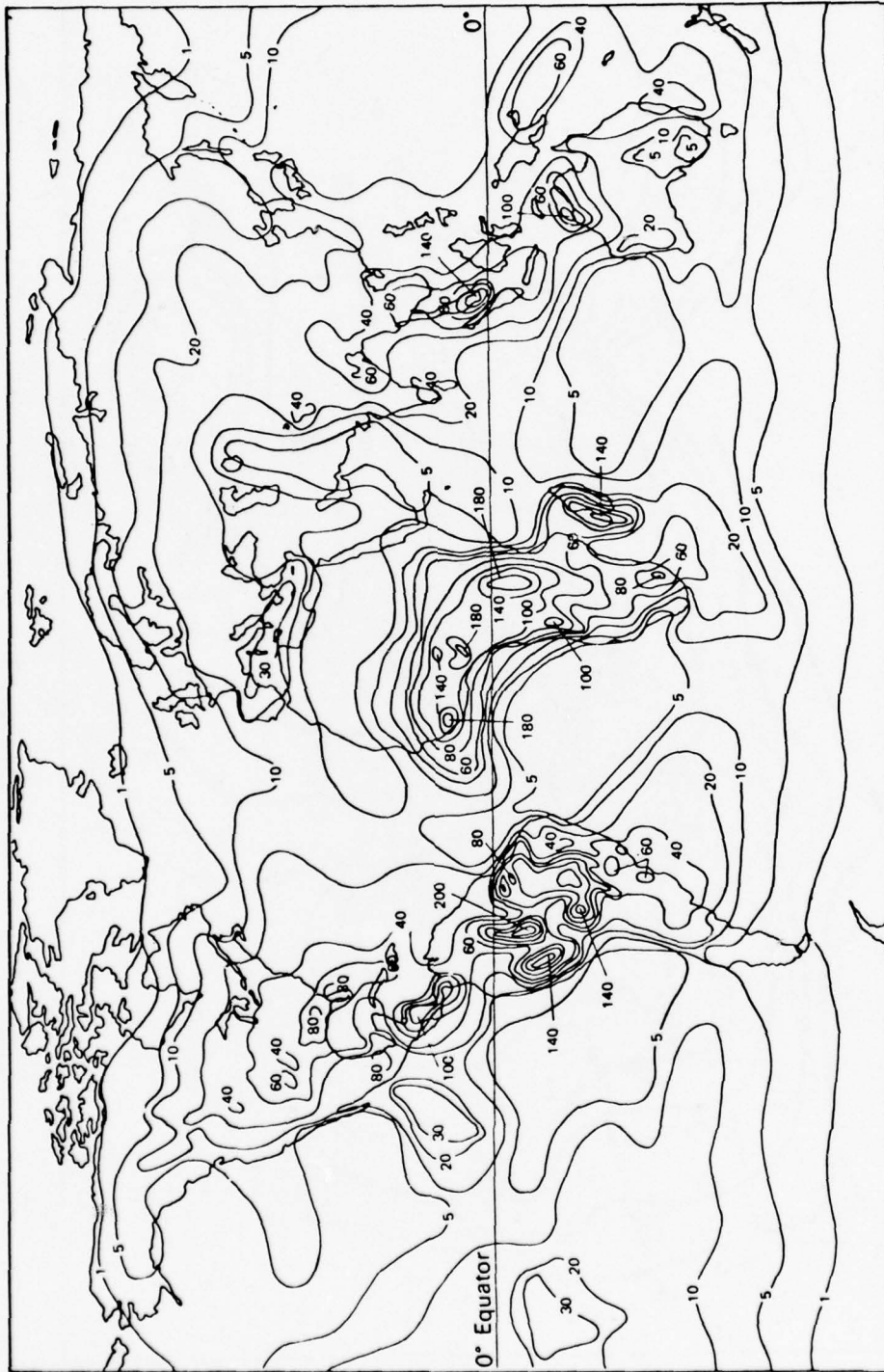

Figure 1. World Isokeraunic Map (for 1956).

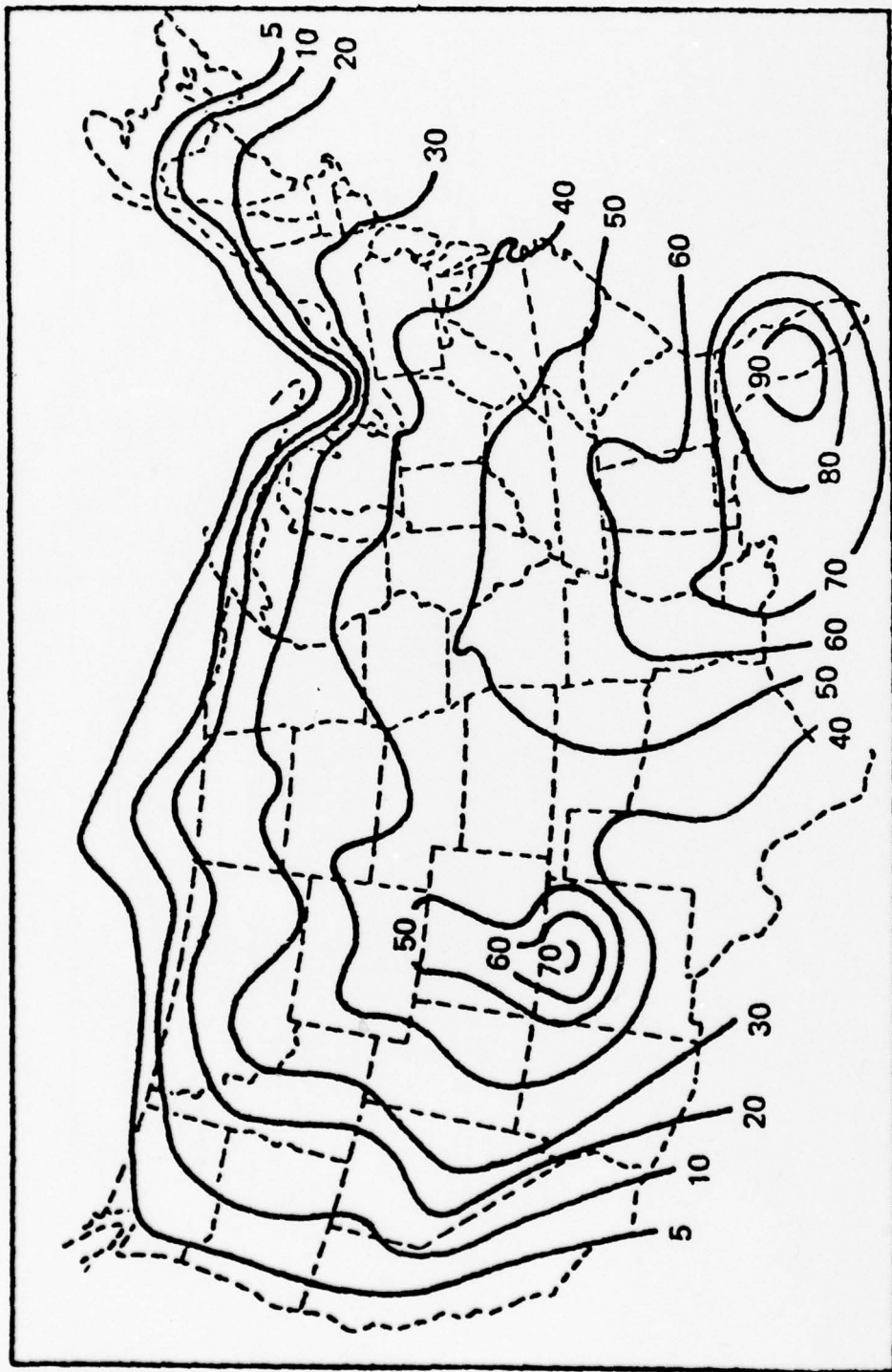

Figure 2. Isokeraunic Map of U.S. (for 1956).

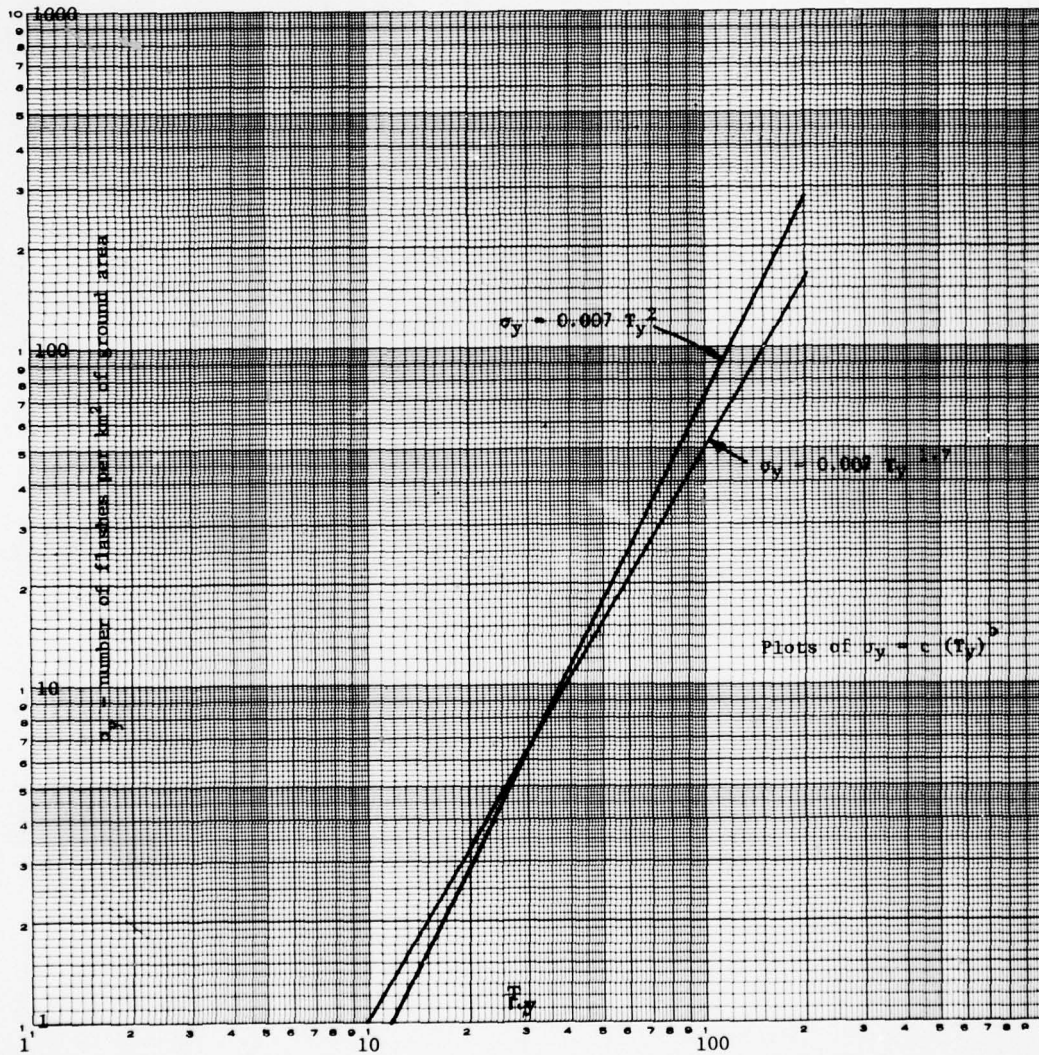

Figure 3. Plots of $\sigma_y = c(T_y)^b$.

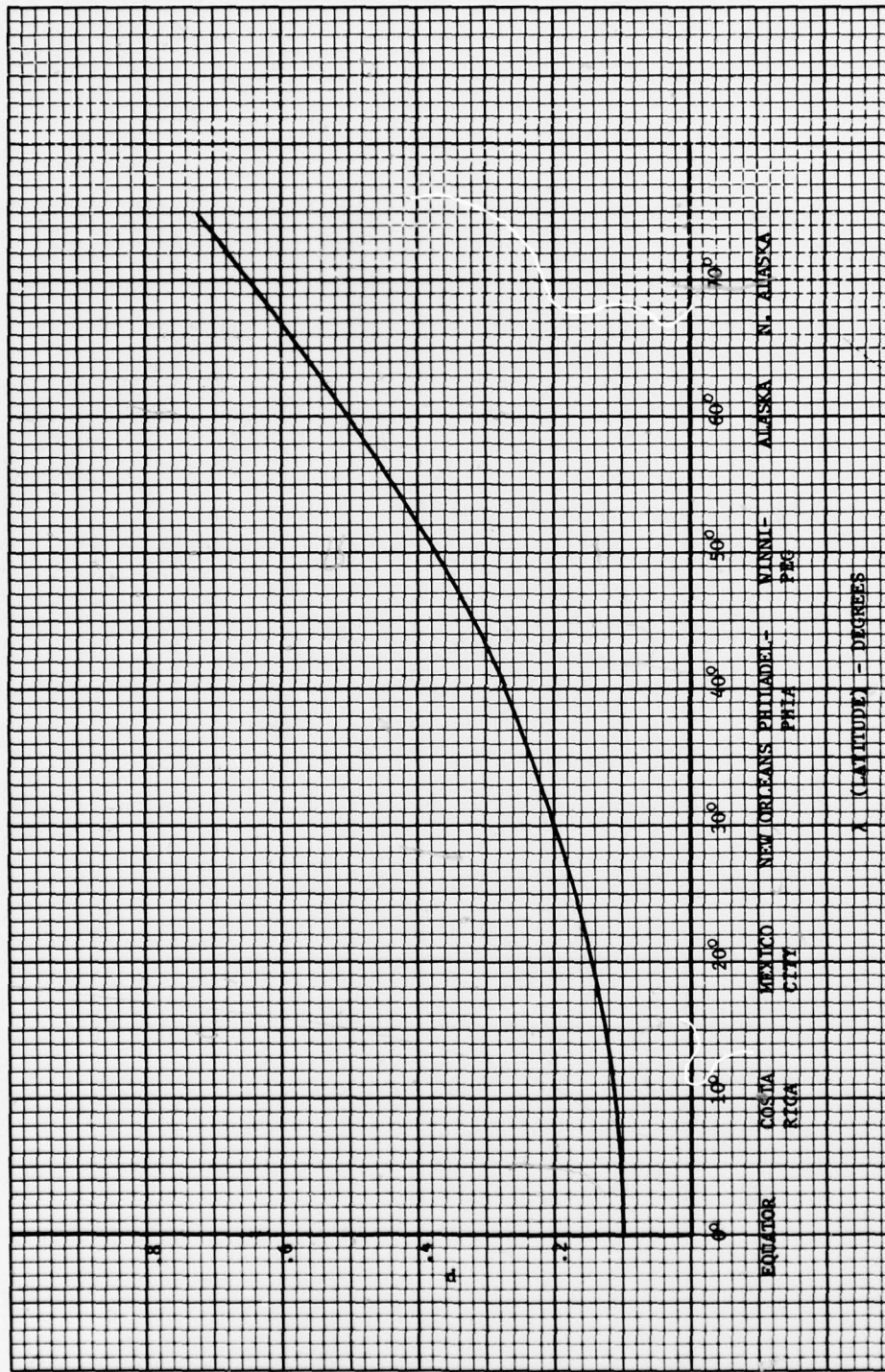

Figure 4. Plot of $p = 0.1 [1 + (\frac{\lambda}{30})^2]$.

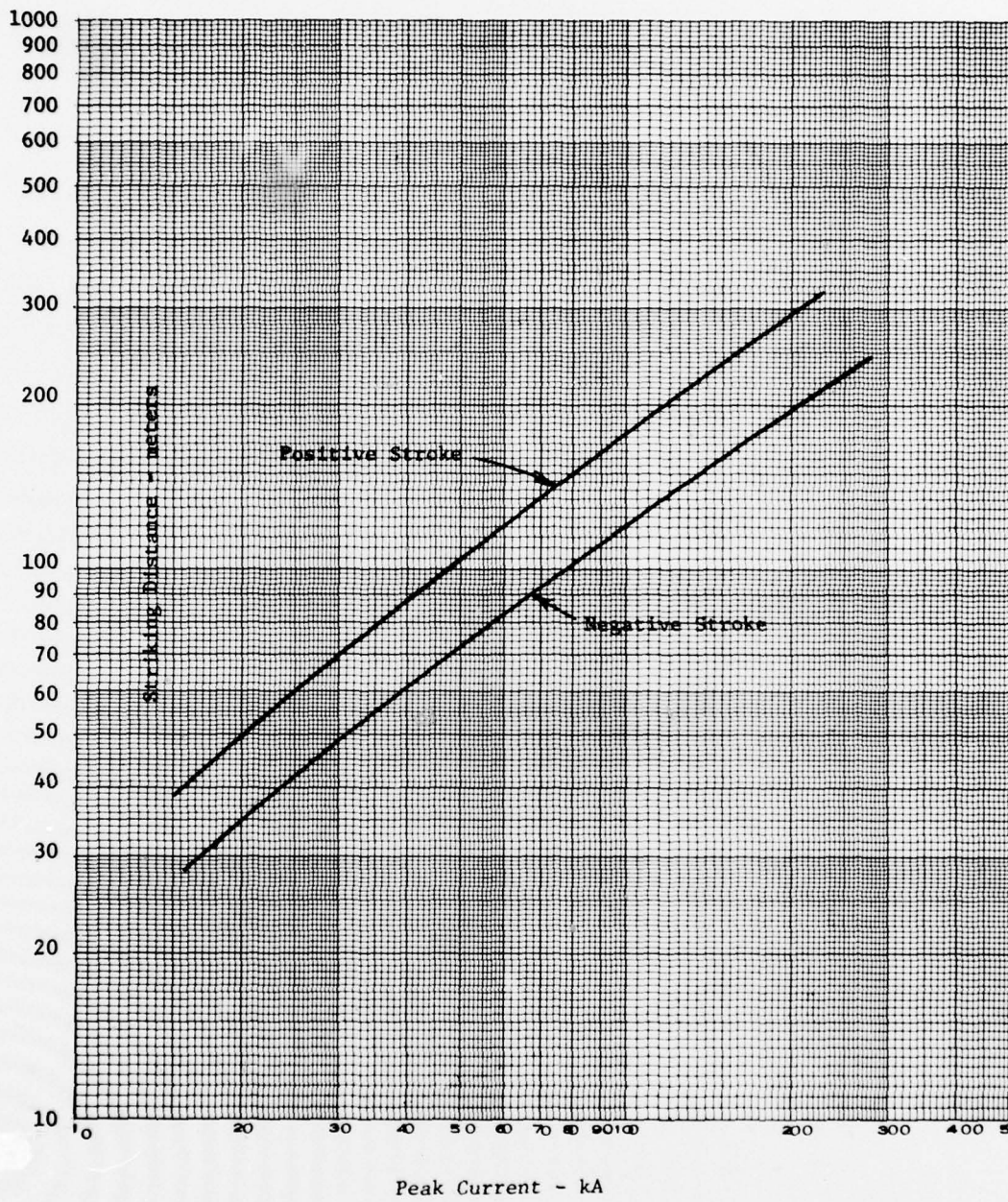

Figure 5. Variation of striking distance with peak lightning current.

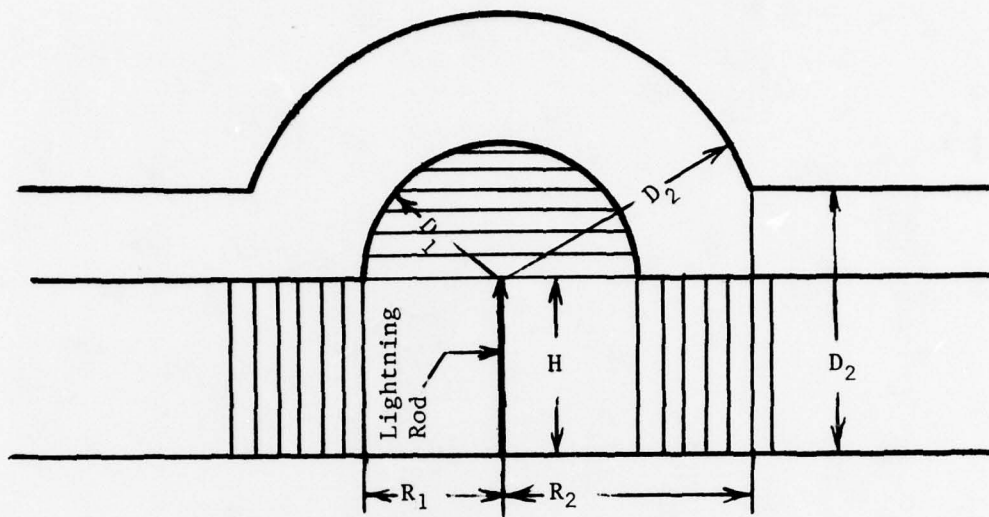

Figure 6. Protective zone of a vertical lightning rod.

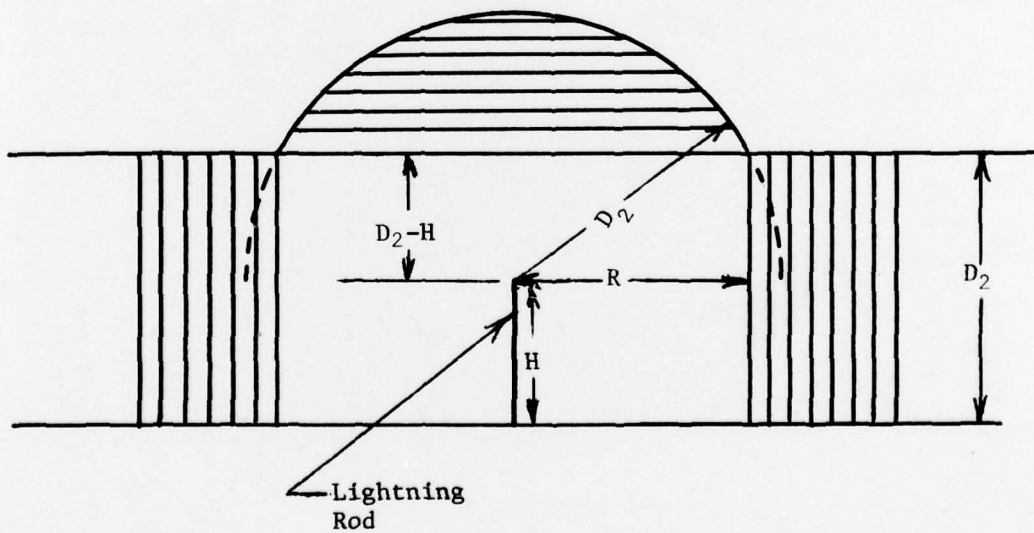

Figure 7. Detail of figure 6 for computation of R when $D_2 > H$.

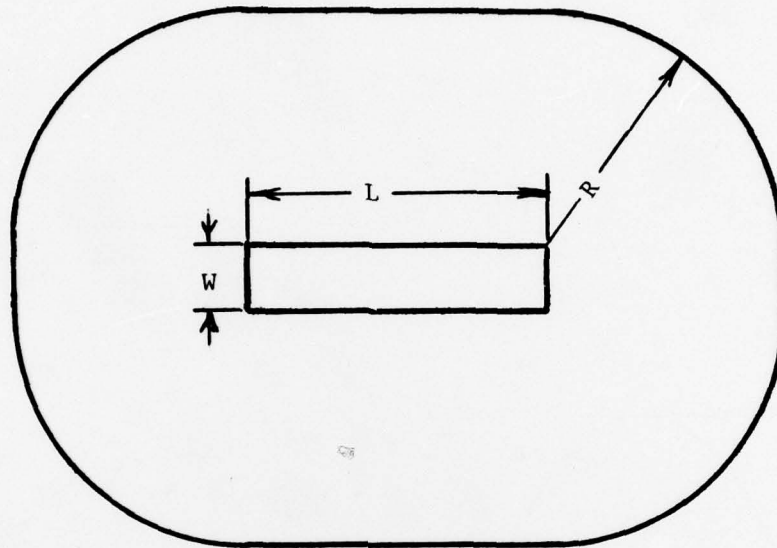

Figure 8. Representation of attractive area.

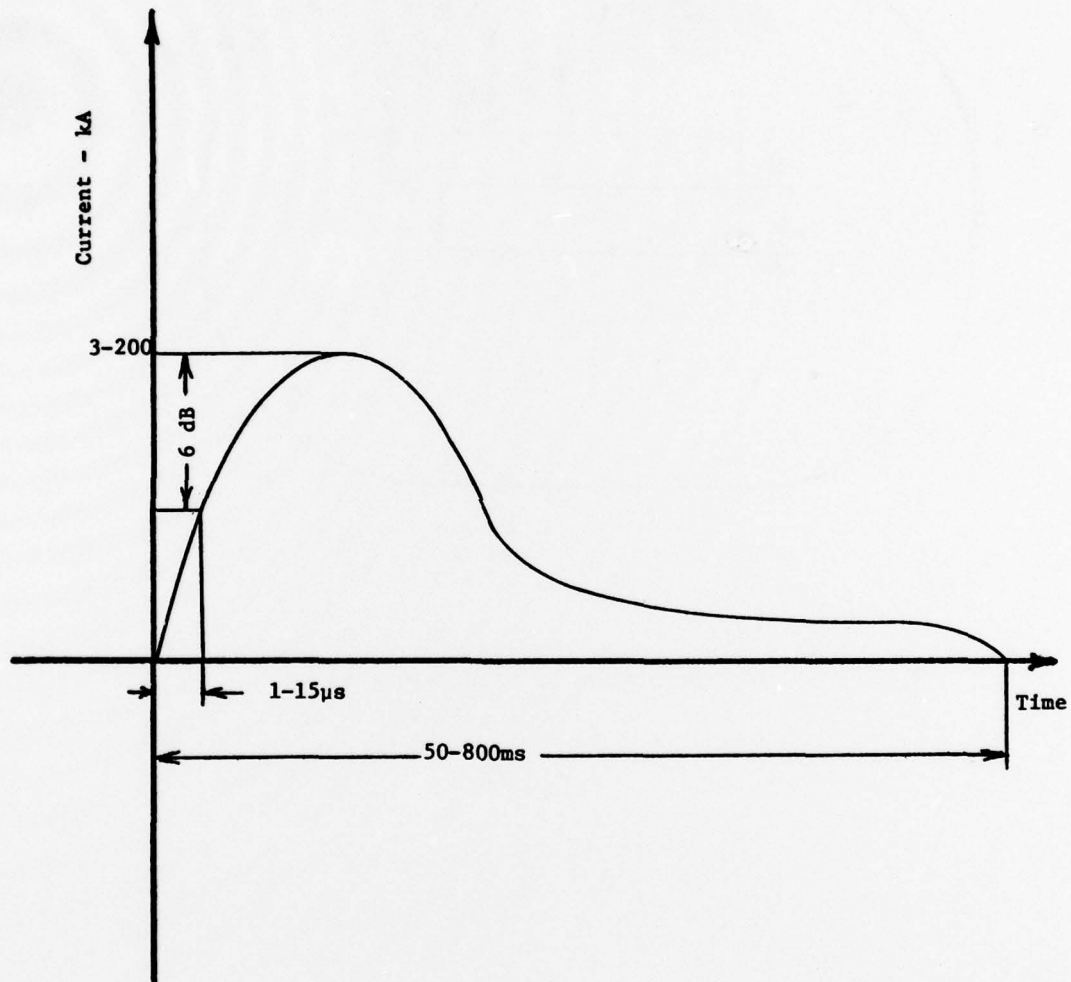
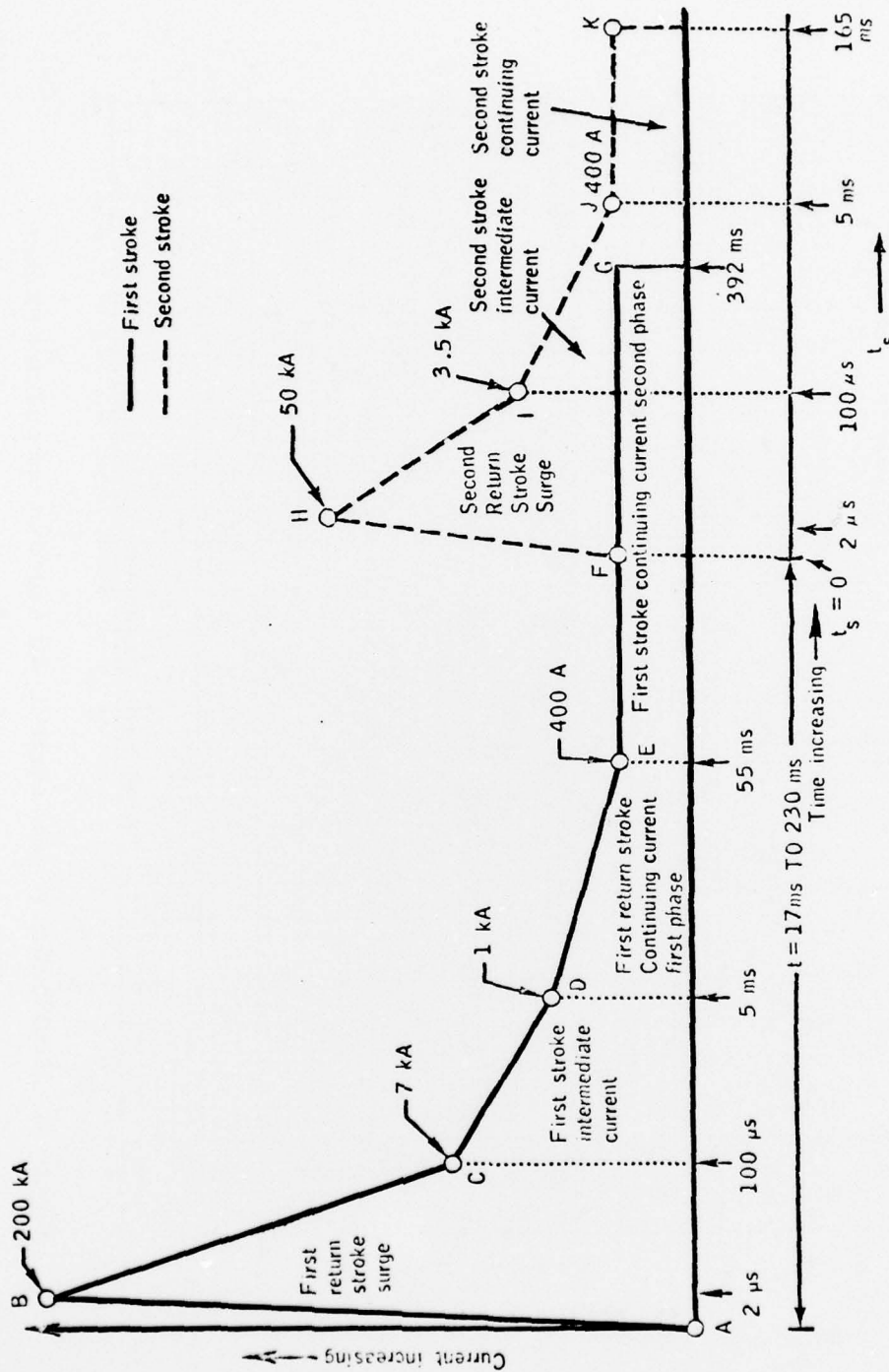

Figure 9. Typical lightning stroke.



(Note that the diagram is not to scale.)

Figure 10. Model of worst-case lightning flash (due to NASA).

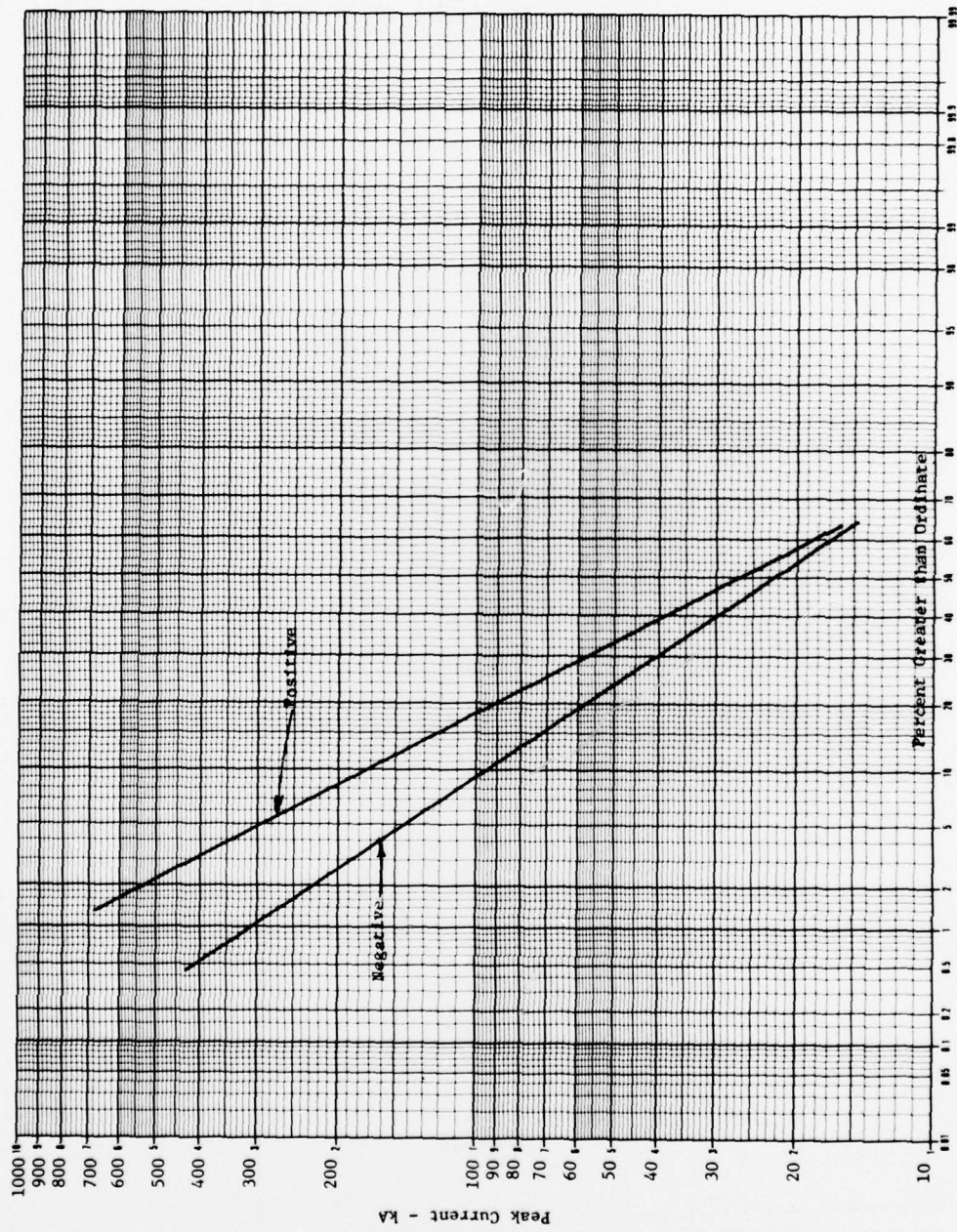

Figure 11. Distribution of peak currents for negative and positive strokes.

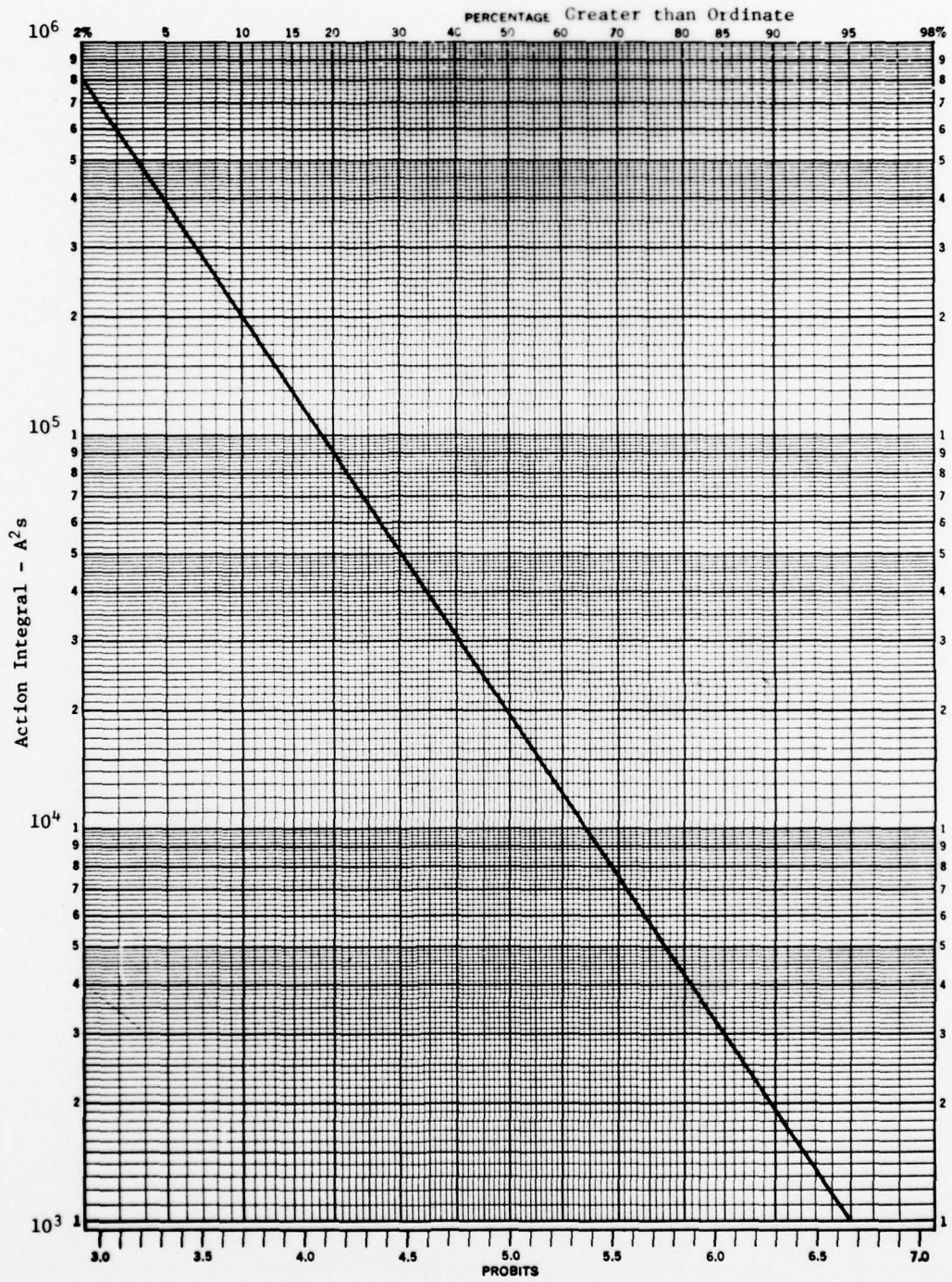

Figure 12. Distribution of action integrals for flashes.

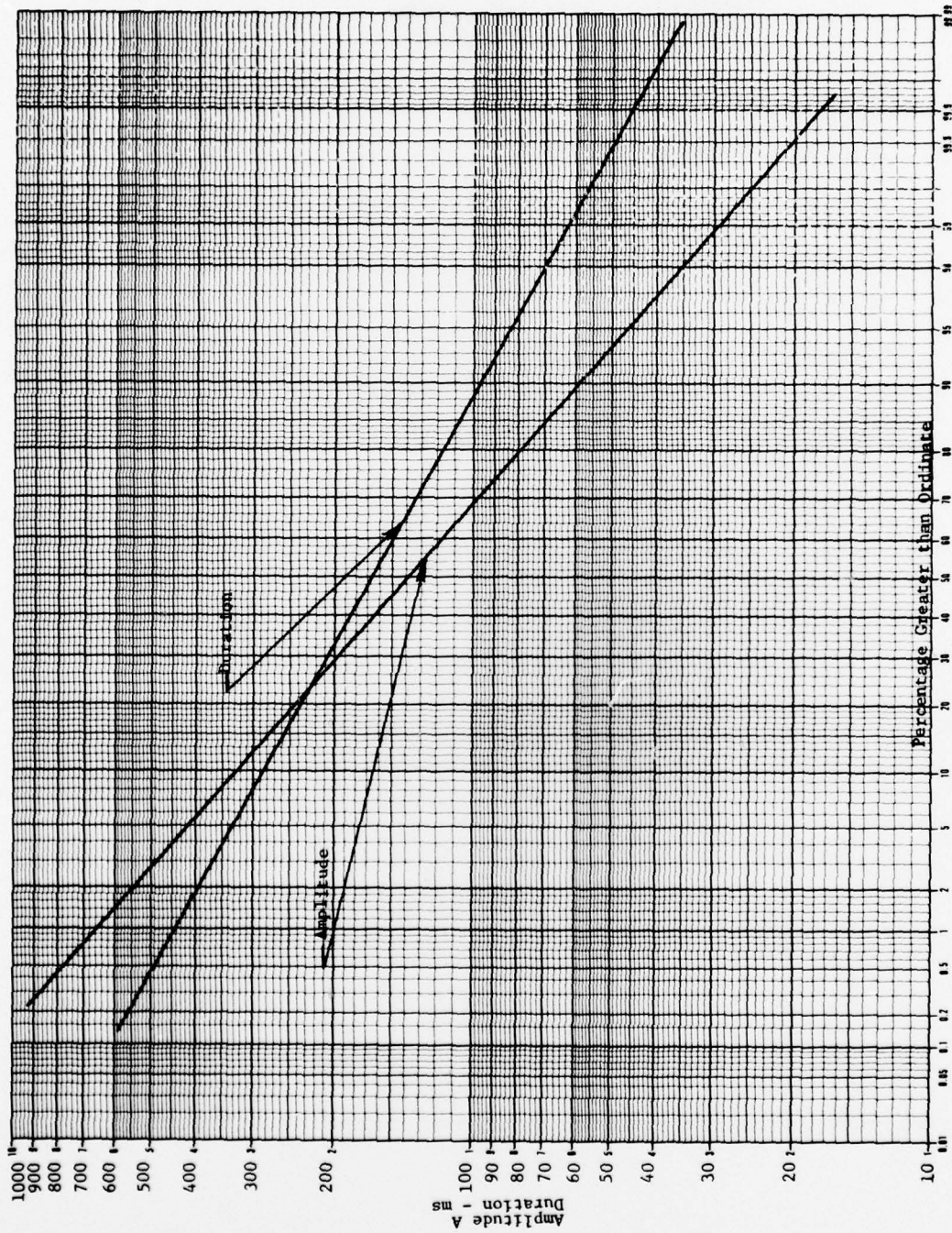

Figure 13. Distribution of amplitudes and durations of continuing currents.

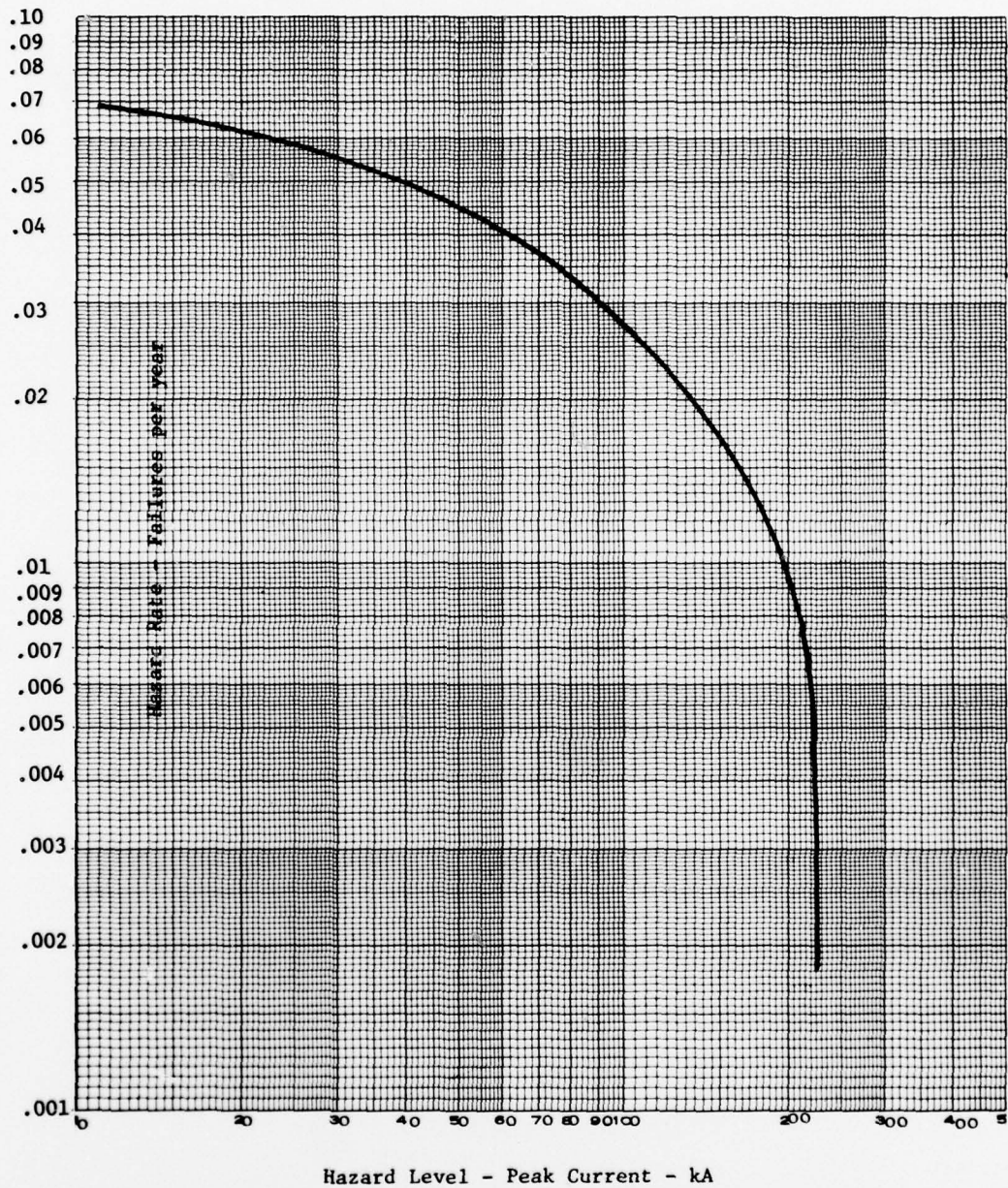

Figure 14. Variation of hazard rate with hazard level.

DISTRIBUTION LIST

| | <u>No. of Copies</u> |
|--|----------------------|
| Defense Documentation Center Cameron Station Alexandria, Virginia 22314 | 12 |
| US Army Armament Materiel Readiness Command ATTN: DRSAR-LEP-L Rock Island, IL 61299 | 1 |
| Commander US Army Materiel Development and Readiness Command ATTN: DRXAM-TL 5001 Eisenhower Avenue Alexandria, VA 22333 | 1 |
| Headquarters, Department of the Army ATTN: ANRAL Washington, DC 20310 | 1 |
| Commander US Army Nuclear Agency ATTN: MONA-MS MONA-SU 7500 Backlick Road Building 2073 Springfield, VA 22150 | 1 1 |
| Commander Harry Diamond Laboratories ATTN: DELHD-TI Adelphi, MD 20783 | 1 |
| Commander US Army Test and Evaluation Command ATTN: DRSTE-FA Aberdeen Proving Ground, MD 21005 | 1 |

| | |
|--|----------------------------|
| Director US Army Materiel Systems Analysis Agency Aberdeen Proving Ground, MD 21005 | 1 |
| Commander Field Command, Defense Nuclear Agency Technical Publications ATTN: FCSR-PD Kirtland Air Force Base Albuquerque, NM 87115 | 1 |
| Commander US Army Materiel Development and Readiness Command Field Office PO Box 5390 Albuquerque, NM 87115 | 1 |
| Commander US Army Materiel Development and Readiness Command ATTN: DRCPM-NUC DRCDM-PBM DRCDM-GCM-M DRCDM-CAWS DRCDM-SA DRCDM-ADG Dover, NJ 07801 | 1 1 1 1 1 1 |
| Commander Ballistics Research Laboratories ATTN: DRDAR-BL DRDAR-BLU Aberdeen Proving Ground, MD 21005 | 1 1 |
| Commander US Army Missile Research and Development Command Redstone Scientific Information Center ATTN: DRDMI-TBD DRDMI-ETR DRSMI-O Redstone Arsenal, AL 35809 | 1 1 1 |

Commander 1
US Army Armament Materiel Readiness Command
ATTN: DRSAR-LR
Dover, NJ 07801

Commander
US Army Armament Research and Development
Command 1
Chemical Systems Laboratory
ATTN: DRDAR-CL
Aberdeen Proving Ground, MD 21005

Commander
US Army Armament Research and Development
Command
ATTN: Library 5
DRDAR-LCA 1
DRDAR-LCM 1
DRDAR-LCS 1
DRDAR-LCW 1
DRDAR-LCB 1
DRDAR-LCF 1
DRDAR-ICN 1
DRDAR-LCU 1
DRDAR-SC 1
DRDAR-TS 1
DRDAR-TSI 1
DRDAR-QA 1
DRDAR-SE 1
DRDAR-LCS-W 20
Dover, NJ 07801

Weapon System Concept Team/CSL
ATTN: DRDAR-ACW 1
Aberdeen Proving Ground, MD 21010

Technical Library
ATTN: DRDAR-CLJ-L 1
Aberdeen Proving Ground, MD 21010

Technical Library
ATTN: DRDAR-TSB-S 1
Aberdeen Proving Ground, MD 21005

Benet Weapons Laboratory 1
Technical Library
ATTN: DRDAR-LCB-TL
Watervliet, NY 12189

Commander
U.S. Army Armament Materiel Readiness Command
ATTN: DRSAR-LEP-L 1
Rock Island, IL 61299

Director
U.S. Army TRADOC Systems Analysis Activity
ATTN: ATAA-SL (Tech Lib) 1
White Sands Missile Range, NM 88002

U.S. Army Materiel Systems Analysis Activity
ATTN: DRXSY-MP 1
Aberdeen Proving Ground, MD 21005