

AD-A064 643

AEROSPACE MEDICAL RESEARCH LAB WRIGHT-PATTERSON AFB OHIO F/G 12/1  
UNSTEADY-STATE RESPONSE OF THE VASCULAR SYSTEM TO TRANSIENT AND--ETC(U)  
1978 X J AVULA, H L OESTREICHER  
AMRL-TR-78-66

UNCLASSIFIED

NL

1 OF 1  
ADA  
084643



END  
DATE  
FILMED

4-79  
DDC

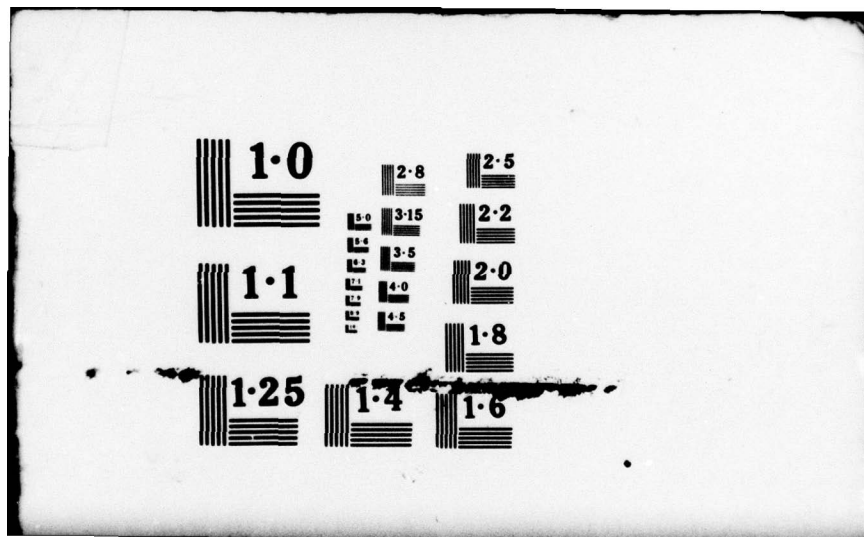

REPORT DOCUMENTATION PAGE

2  
READ INSTRUCTIONS  
BEFORE COMPLETING FORM

ADA064643

DDC FILE COPY

1. REPORT NUMBER AMRL-TR-78-66	2. GOVT ACCESSION NO.	3. RECIPIENT'S CATALOG NUMBER
4. TITLE (and Subtitle) UNSTEADY-STATE RESPONSE OF THE VASCULAR SYSTEM TO TRANSIENT AND SUSTAINED AEROSPACE ACCELERATION PROFILES		5. TYPE OF REPORT & PERIOD COVERED Reprint
7. AUTHOR(s) Xavier S. R. Avula* Hans L. Oestreicher**		8. CONTRACT OR GRANT NUMBER(s) 11 1978
9. PERFORMING ORGANIZATION NAME AND ADDRESS **Aerospace Medical Research Laboratory, Aerospace Medical Division, Air Force Systems Command Wright-Patterson Air Force Base, Ohio 45433		10. PROGRAM ELEMENT, PROJECT, TASK AREA & WORK UNIT NUMBERS 62202F; 7231-15-02
11. CONTROLLING OFFICE NAME AND ADDRESS 17 45   12 44 P'		12. REPORT DATE November 1978
14. MONITORING AGENCY NAME & ADDRESS (if different from Controlling Office)		13. NUMBER OF PAGES 8
		15. SECURITY CLASS. (of this report) Unclassified
		15a. DECLASSIFICATION/DOWNGRADING SCHEDULE

16. DISTRIBUTION STATEMENT (of this Report)  
Approved for release to the public; distribution unlimited

D D C  
 REPRINT  
 FEB 14 1979  
 C

17. DISTRIBUTION STATEMENT (of the abstract entered in Block 20, if different from Report)

18. SUPPLEMENTARY NOTES  
Presented at the Aerospace Medical Panel Specialists' Meeting in Paris, France, 6-10 November 1978; and reprinted from AGARD Conference Preprint No. 253 Models and Analogues for the Evaluation of Human Biodynamic Response, Performance and Protection. (Continued)

19. KEY WORDS (Continue on reverse side if necessary and identify by block number)

20. ABSTRACT (Continue on reverse side if necessary and identify by block number)  
In this study a mathematical method to determine the response of the blood vessels to transient and sustained acceleration forces is presented. The method is based on coupling of the Navier-Stokes equations for blood flow and the large elastic deformation theory for the deformation of the blood vessels, and solving them numerically under the appropriate initial and boundary conditions. A mathematical reasoning to neglect the effect of acceleration on microcirculation per se is given. However, microcirculation is indirectly affected by acceleration forces which tend to pool blood and bring about pressure changes in large vessels. Aortic pressures are calculated for examples of monotonically increasing and transient -G acceleration profiles, and one of the solutions is compared with an available, experimentally measured pressure from an animal experiment. In the absence of proper physiological scaling laws, the qualitative agreement between the theory and experiment is satisfactory.

18. Continued: \*Dr. Avula is from University of Missouri-Rolla, Rolla, Missouri 65401. He was working with AMRL on an AFOSR grant.

8A0P00A0A  
DDC LIFE COPY

ACCESSION for	White Section <input checked="" type="checkbox"/>
	Buff Section <input type="checkbox"/>
NTIS	
DDC	
UNANNOUNCED	
JUSTIFIABILITY	
BY	DISTRIBUTION AVAILABILITY CODES
	SP CIAL
A	

UNSTEADY-STATE RESPONSE OF THE VASCULAR SYSTEM TO  
TRANSIENT AND SUSTAINED AEROSPACE ACCELERATION PROFILES

Xavier J.R. Avula  
Professor of Engineering Mechanics  
University of Missouri-Rolla  
Rolla, Missouri 65401 U.S.A.

and

Hans L. Oestreicher  
Chief, Mathematics and Analysis Branch  
Biodynamics and Bioengineering Division  
Aerospace Medical Research Laboratory  
Wright-Patterson Air Force Base, Ohio 45433 U.S.A.

SUMMARY

In this study a mathematical method to determine the response of the blood vessels to transient and sustained acceleration forces is presented. The method is based on coupling of the Navier-Stokes equations for blood flow and the large elastic deformation theory for the deformation of the blood vessels, and solving them numerically under the appropriate initial and boundary conditions. A mathematical reasoning to neglect the effect of acceleration on microcirculation *per se* is given. However, microcirculation is indirectly affected by acceleration forces which tend to pool blood and bring about pressure changes in large vessels. Aortic pressures are calculated for examples of monotonically increasing and transient  $-G_z$  acceleration profiles, and one of the solutions is compared with an available, experimentally measured pressure from an animal experiment. In the absence of proper physiological scaling laws, the qualitative agreement between the theory and experiment is satisfactory.

INTRODUCTION

Recent developments in spacecraft and high performance aircraft have resulted in the exposure of the human body to the hazards of high accelerations beyond tolerance levels. In addition to injury to various parts of the body, cardiac insufficiency and the consequent physiological malfunctions such as headache, abdominal pain, change in heart rate, chest pain, loss of vision and hemorrhage are some of the manifestations of acceleration trauma. The knowledge of the response of the cardiovascular system to acceleration stress is essential to the development of protective devices which are designed to increase acceleration tolerance by the human body during aircraft and spacecraft maneuvers. The objective of the present investigation is to understand the response of the blood vessels to transient and sustained aerospace acceleration profiles.

Since it is impossible to actually subject the human body to abnormal high accelerations without inflicting an injury, the response of the vascular system to transient and sustained accelerations is investigated mathematically. Theoretical analyses are extremely helpful for evaluating the relative injury potential for various acceleration functions, in guiding experimental investigations, and in developing and understanding protective measures. Mathematical procedures also provide the basis for establishing precise dynamic and physiological scaling laws needed to translate experimental data obtained with various species into meaningful results for humans.

In recent years, numerous mathematical investigations of arterial dynamics have appeared in the scientific literature. Womersley [1] and Noordergraaf [2] have presented a mathematical analysis of blood flow through arteries by using a lumped parameter model. Taylor [3], Kenner [4], Attinger et. al. [5] used distributed parameter models to analyze pressure-flow relationships in arteries and veins. Several articles related to blood flow in arteries have appeared in the book by McDonald [6]. An elastic tube theory of blood flow has been treated by Lambert [7] and Skalak and Stathis [8]. Kivity and Collins [9] presented a viscoelastic tube model for aortic rupture under decelerative forces. Rudinger [10] studied the effect of shock waves on mathematical models of aorta for better understanding of the behavior of the actual aorta.

To understand the blood flow characteristics in the arterial system, the knowledge of the material properties of the arterial wall is essential. Bergel [11], Fung [12], Demiray and Vito [13] have utilized mathematical models of the constitutive properties of the arterial tissue to determine the stresses in the arterial walls. In the present study, the strain energy function given by Demiray and Vito [13] for an arterial wall specimen has been used in determining the aortic pressure that is compatible with large deformation of the aorta and the associated flow under acceleration stress.

The present study also considers the effect of acceleration on the microcirculation. Microcirculation under normal conditions was investigated by Prothero and Burton [14], Whitmore [15], Gross and Aroesty [16], Gross and Intaglietta [17], Skalak [18] and Fung [19] who presented various theories of flow in the capillary bed connecting the arteries and veins.

Several experimental investigations on the effects of acceleration stress on the human body have been performed at the USAF School of Aerospace Medicine at Brooks Air Force Base, Texas. Burton [20] subjected miniature swine to  $G_z$  acceleration to study its effects on the organism and extrapolated the results to human beings. Parkhurst, et. al. [21] conducted experiments on human tolerance to high  $+G_z$  forces. Leverett, et. al. [22] investigated the physiologic response to high sustained acceleration stress. Peterson, et. al. [23] studied the cardiovascular responses during and following exposure to  $+G_z$  forces in chronically instrumented anesthetized dogs. Burton and MacKenzie [24] determined the extent of heart pathology as a function of acceleration stress.

79 02 09 066

## MATHEMATICAL FORMULATION

## A. Equations of Fluid Motion

The geometry of the elastic tube containing blood in motion is shown in Fig. 1. Let  $r, \theta, z$  be the cylindrical polar coordinates and let  $u, v,$  and  $w$  be the velocity components in the corresponding directions. Assuming axial symmetry in flow and tube deformation, the Navier-Stokes equations for the flow of blood can be written as:

$$\frac{\partial u}{\partial t} + u \frac{\partial u}{\partial r} + w \frac{\partial u}{\partial z} = -\frac{1}{\rho_0} \frac{\partial p}{\partial r} + \nu \left[ \frac{\partial^2 u}{\partial r^2} + \frac{1}{r} \frac{\partial u}{\partial r} + \frac{\partial^2 u}{\partial z^2} - \frac{u}{r^2} \right] \quad (1)$$

$$\frac{\partial w}{\partial t} + u \frac{\partial w}{\partial r} + w \frac{\partial w}{\partial z} = -\frac{1}{\rho_0} \frac{\partial p}{\partial z} + \nu \left[ \frac{\partial^2 w}{\partial r^2} + \frac{1}{r} \frac{\partial w}{\partial r} + \frac{\partial^2 w}{\partial z^2} \right] + g(t) \quad (2)$$

where  $p$  is the pressure,  $\nu$  is the kinematic viscosity,  $\rho_0$  is density of blood and  $g(t)$  is the body force per unit mass caused by the acceleration. The continuity equation is

$$\frac{\partial u}{\partial r} + \frac{u}{r} + \frac{\partial w}{\partial z} = 0 \quad (3)$$

The above equations are nondimensionalized using a typical length,  $R_0$ , which is the initial (undeformed) radius of the aorta, and  $U$ , the average velocity of blood in the aorta. Introducing the new quantities

$$t^* = \frac{tU}{R_0} \quad r^* = \frac{r}{R_0} \quad z^* = \frac{z}{R_0} \quad w^* = \frac{w}{U} \quad (4)$$

$$u^* = \frac{u}{U} \quad p^* = \frac{p}{\rho_0 U^2} \quad g^* = \frac{R_0 g}{U^2} \quad Re = \frac{UR_0}{\nu}$$

the equations of motion and the continuity equation in terms of the newly defined variables become

$$\frac{\partial u^*}{\partial t^*} + u^* \frac{\partial u^*}{\partial r^*} + w^* \frac{\partial u^*}{\partial z^*} = -\frac{\partial p^*}{\partial r^*} + \frac{1}{Re} \left[ \frac{\partial^2 u^*}{\partial r^{*2}} + \frac{1}{r^*} \frac{\partial u^*}{\partial r^*} + \frac{\partial^2 u^*}{\partial z^{*2}} - \frac{u^*}{r^{*2}} \right] \quad (5)$$

$$\frac{\partial w^*}{\partial t^*} + u^* \frac{\partial w^*}{\partial r^*} + w^* \frac{\partial w^*}{\partial z^*} = -\frac{\partial p^*}{\partial z^*} + \frac{1}{Re} \left[ \frac{\partial^2 w^*}{\partial r^{*2}} + \frac{1}{r^*} \frac{\partial w^*}{\partial r^*} + \frac{\partial^2 w^*}{\partial z^{*2}} \right] + g^*(t^*) \quad (6)$$

$$\frac{\partial u^*}{\partial r^*} + \frac{u^*}{r^*} + \frac{\partial w^*}{\partial z^*} = 0 \quad (7)$$

Deleting the "stars" for simplicity, the governing equations in the dimensionless form will become

$$\frac{\partial u}{\partial t} + u \frac{\partial u}{\partial r} + w \frac{\partial u}{\partial z} = -\frac{\partial p}{\partial r} + \frac{1}{Re} \left( \frac{\partial^2 u}{\partial r^2} + \frac{1}{r} \frac{\partial u}{\partial r} + \frac{\partial^2 u}{\partial z^2} - \frac{u}{r^2} \right) \quad (8)$$

$$\frac{\partial w}{\partial t} + u \frac{\partial w}{\partial r} + w \frac{\partial w}{\partial z} = -\frac{\partial p}{\partial z} + \frac{1}{Re} \left( \frac{\partial^2 w}{\partial r^2} + \frac{1}{r} \frac{\partial w}{\partial r} + \frac{\partial^2 w}{\partial z^2} \right) + g(t) \quad (9)$$

$$\frac{\partial u}{\partial r} + \frac{u}{r} + \frac{\partial w}{\partial z} = 0 \quad (10)$$

The boundary and initial conditions are

$$\begin{aligned} u &= \frac{dR_1}{dt} & \text{at } r &= R_1 & t &\geq 0 \\ w &= 0 & \text{at } r &= R_1 & t &\geq 0 \\ w &= 1 & \text{at } z &= 0 & t &\geq 0 \end{aligned} \quad (11)$$

where  $R_1$  is the inside radius of the blood vessel in the deformed state.

## B. Equations of Motion for Thin-walled Elastic Tube:

The theory of large elastic deformations is utilized to describe the time-dependent deformation of the blood vessels. In view of the published results on blood pooling and the consequent cardiac insufficiency, the application of large deformation theory appears necessary. Demiray and Vito [13] have previously used this theory to calculate the deformation of arteries.

The undeformed and deformed cylindrical tubes are shown in Fig. 2. Let  $r, \theta, z$  represent a point in the wall of the undeformed tube, and  $R, \theta, z$  in the deformed tube.  $r_1, r_2$  are inside and outside radii, respectively, of the undeformed tube, and  $R_1, R_2$  those of the deformed tube. Axial stretch of the tube is neglected because of tethering caused by the surrounding tissue. Assuming the material of the blood vessels to be homogeneous, incompressible, and isotropic, the stress at any point can be written as:

$$\tau^{ij} = \phi g^{ij} + \phi B^{ij} + \phi C^{ij} \quad (12)$$

where  $\phi = 2(\partial W/\partial I_1)$ ,  $\psi = 2(\partial W/\partial I_2)$ ,  $B^{ij} = I_1 g^{ij} - g^{ir} g^{js} G_{rs}$ ,  $P$  is a scalar function which represents a hydrostatic pressure,  $W$  is the strain energy function,  $I_1$  and  $I_2$  are the strain invariants, and  $g^{ij}$ ,  $g_{ij}$ ,  $G^{ij}$ , and  $G_{ij}$  are the contravariant and covariant metric tensors [25, 26]. The indices  $i$  and  $j$  take the values 1, 2, and 3. The equations of motion are given by:

$$\tau^{ij} \parallel_i + \rho_w F^j = \rho_w f^j \quad (13)$$

where  $\parallel$  denotes covariant differentiation,  $\rho_w$  is the density of the vessel wall,  $F$  is the body force, and  $f$  is the acceleration. Let us neglect the body force on the vessel wall in comparison to its effect on the fluid flowing in the cylindrical tube. Performing the covariant differentiation on the remaining part of the equation of motion we get

$$\tau^{ij} \parallel_i + \Gamma^i_{ir} \tau^{rj} + \Gamma^i_{ir} \tau^{ir} = \rho_w f^j \quad (14)$$

where  $\Gamma^i_{jk}$  represent the Christoffel symbols of the second kind [25, 26].

It has been shown that for a biomaterial, a reasonable strain energy function as shown in [13] is

$$W = \frac{\beta}{2\alpha} \left[ e^{\alpha(I_2 - 3)} - 1 \right] \quad (15)$$

in which  $\alpha$  and  $\beta$  are material constants. Defining the circumferential stretch ratio  $\lambda = R/r$ , the stresses in the  $r$ ,  $\theta$ ,  $z$  directions can be expressed as

$$\tau^{11} = P + \beta \left( 1 + \frac{1}{\lambda^2} \right) e^{\alpha(I_2 - 3)} \quad (16)$$

$$R^2 \tau^{22} = P + \beta (1 + \lambda^2) e^{\alpha(I_2 - 3)} \quad (17)$$

$$\tau^{33} = P + \beta \left( \frac{1}{\lambda^2} + \lambda^2 \right) e^{\alpha(I_2 - 3)} \quad (18)$$

Substitution of the above equations and the appropriate Christoffel symbols in Eq. (14) gives the equation of motion in the form

$$\frac{\partial}{\partial R} \left[ P + \beta \left( 1 + \frac{1}{\lambda^2} \right) e^{\alpha(I_2 - 3)} \right] + \frac{\beta}{R} \left( \frac{1}{\lambda^2} - \lambda^2 \right) e^{\alpha(I_2 - 3)} = \rho_w \frac{\partial^2 R}{\partial t^2} \quad (19)$$

The incompressibility condition leads to:

$$R^2 - R_1^2 = r^2 - r_1^2 \quad (20)$$

and

$$\frac{\partial^2 R}{\partial t^2} = -\frac{R^2}{R^3} \left( \frac{dR_1}{dt} \right)^2 + \frac{1}{R} \left( \frac{dR_1}{dt} \right)^2 + \frac{R_1}{R} \frac{d^2 R_1}{dt^2} \quad (21)$$

With  $p_1$ ,  $p_2$  denoting the pressure on the inside and outside wall, respectively, of the blood vessel, the use of the boundary conditions,  $\tau^{11} = -p_1(t)$  at  $R = R_1$  and  $\tau^{11} = -p_2(t)$  at  $R = R_2$ , substituting Eq. (21) into Eq. (19) and integrating yields

$$p_1(t) - p_2(t) = \rho_w R_1 \frac{d^2 R_1}{dt^2} \ln \frac{R_2}{R_1} + \left( \frac{dR_1}{dt} \right)^2 \rho_w \left[ \ln \frac{R_2}{R_1} + \frac{1}{2} \left( \frac{R_2^2}{R_1^2} - 1 \right) \right] - \beta \int_{\lambda_1}^{\lambda_2} \frac{1+\lambda^2}{\lambda^3} e^{\alpha(\lambda^2 + 1/\lambda^2 - 2)} d\lambda \quad (22)$$

It must be recognized that the relationship  $I_2 = 1 + \lambda^2 + 1/\lambda^2$  has been used to obtain Eq. (22).

The following dimensionless quantities are introduced into Eq. (22):

$$P^* = \frac{P}{\rho_0 U^2}, \quad R_1^* = \frac{R_1}{R_0}, \quad R_2^* = \frac{R_2}{R_0}, \quad t^* = \frac{tU}{R_0}, \quad \beta^* = \frac{\beta}{\rho_0 U^2}, \quad \rho_w^* = \frac{\rho_w}{\rho_0} \quad (23)$$

Then the equation of motion in the radial direction becomes

$$(P_1^* - P_2^*) = \rho_w^* R_1^* \frac{d^2 R_1^*}{dt^{*2}} \ln \left( \frac{R_2^*}{R_1^*} \right) + \rho_w^* \left( \frac{dR_1^*}{dt^*} \right)^2 \left[ \ln \frac{R_2^*}{R_1^*} + \frac{1}{2} \left( \frac{R_2^{*2}}{R_1^{*2}} - 1 \right) \right] - \beta^* \int_{\lambda_1}^{\lambda_2} \frac{1+\lambda^2}{\lambda^3} e^{\alpha(\lambda^2 + 1/\lambda^2 - 2)} d\lambda \quad (24)$$

If the "stars" are dropped for convenience, Eq. (24) can be written as:

$$\begin{aligned}
 P_1(t) - P_2(t) = & \rho_w R_1 \frac{d^2 R_1}{dt^2} \ln \frac{R_2}{R_1} - \rho_w \left( \frac{dR_1}{dt} \right)^2 \left[ \ln \frac{R_2}{R_1} + \frac{1}{2} \left( \frac{R_2^2}{R_1^2} - 1 \right) \right] \\
 & - \beta \int_{\lambda_1}^{\lambda_2} \frac{1+\lambda^2}{\lambda^3} e^{\alpha(\lambda^2 + 1/\lambda^2 - 2)} d\lambda
 \end{aligned} \tag{25}$$

The initial conditions are:

At time  $t = t_0$ ,  $R_1 = R_0$ ,  $dR_1/dt = u$ , radial velocity of fluid.

### C. Effect of Acceleration on Microcirculation

The blood vessels of microcirculation are extraordinarily small, and their typical dimensions are of the order of microns. Under normal circumstances, the velocity of the blood in the microcirculation is 1 mm/sec and the Reynolds number is of the order  $O(10^{-3})$ , which is sufficiently small so that the Stokes flow approximations are applicable. Neglecting the inertial effects and assuming that the stream lines are nearly parallel, the dimensionless equation of fluid motion in the axial ( $z$ ) direction becomes

$$\frac{\partial w}{\partial t} = - \frac{\partial p}{\partial z} + \frac{1}{Re} \left( \frac{\partial^2 w}{\partial r^2} + \frac{1}{r} \frac{\partial w}{\partial r} + \frac{\partial^2 w}{\partial z^2} \right) + g(t) \tag{26}$$

which can be rearranged to read

$$Re \frac{\partial w}{\partial t} = - Re \left( \frac{\partial p}{\partial z} \right) + \left( \frac{\partial^2 w}{\partial r^2} + \frac{1}{r} \frac{\partial w}{\partial r} + \frac{\partial^2 w}{\partial z^2} \right) + Re g(t) \tag{27}$$

In the earth's natural gravitational field, the dimensionless  $g$ , as given in Eq. (4), is of the order  $O(10^{-2})$ , and with the effect of  $Re \sim O(10^{-3})$  in the last term  $Re g(t)$  in Eq. (27) becomes physiologically insignificant, being of the order  $O(10^{-5})$ . We estimate that the effect of acceleration on microcirculation *per se* can be safely neglected up to 100 g. However, the pressure of the blood pooled in the arteries and veins can affect the flow rate in the small vessels. For this reason it is necessary to determine a relationship between the pressure gradient and the flow rate in the small blood vessels.

For the flow of a Newtonian fluid in a uniform tube Szymanski [27] showed that the flow would be fully developed if  $vt/D^2 \gg 1$ , where  $t$  = time,  $\nu$  = kinematic viscosity, and  $D$  = tube diameter. An extension of this criterion to microcirculation yields  $\nu \Delta t/D^2 \gg 1$  for flow to be quasi-steady, where  $\Delta t$  is the smallest characteristic time of the unsteadiness in flow. According to Burton [28],  $\Delta t \approx 0.1$  sec; using  $\nu = 0.04$  Stokes, one finds that the diameter  $D$  must be greater than  $600\mu$  (microns) for any significant effect of unsteadiness. Since, in microcirculation the diameters of blood vessels are much less than  $600\mu$ , changes in flow due to unsteadiness become entirely negligible. On this basis Benis [29] argued that the effect of unsteadiness on non-Newtonian flow could also be neglected. Thus, the use of steady-flow equations can be justified for microcirculation.

For steady capillary flow, the flow rate through a circular tube can be expressed by

$$Q = 2\pi \int_0^R r w dr \tag{28}$$

where  $Q$  = flowrate,  $R$  = tube radius, and  $w$  = blood velocity. Integration by parts of the right hand side yields

$$Q = \pi \int_0^R d(r^2 w) - \pi \int_0^R r^2 \left( \frac{dw}{dr} \right) dr \tag{29}$$

The first integral on the right hand side of Eq. (29) is zero. In the second integral the domain of integration can be divided into two regions: a cone of unshered fluid extending to radius  $R_y$ , and the annular region bounded by the unshered fluid and the tube wall. Then,

$$Q = - \pi \int_0^{R_y} r^2 \left( \frac{dw}{dr} \right) dr - \pi \int_{R_y}^R r^2 \left( \frac{dw}{dr} \right) dr \tag{30}$$

The first term on the right hand side in Eq. (30) which represents the core integral is zero. By changing the variables from  $r$  to  $\tau$  in the second term as suggested by Merrill et. al. [30], Eq. (30) can be written as

$$Q = \frac{8\pi}{(\Delta P/L)^3} \int_{\tau_y}^{\tau} \tau^2 \dot{\gamma} d\tau \tag{31}$$

where  $L$  = length of the capillary

$\Delta P$  = pressure drop

$\tau$  = shear stress

$\dot{\gamma}$  = shear rate.

The shear stress and the shear rate are related by an empirical equation

$$\tau^{1/2} = \tau_y^{1/2} + \mu^{1/2} \dot{\gamma}^{1/2} \quad (32)$$

in which  $\tau_y$  is the yield shear stress, and  $\mu^{1/2}$  is a constant which represents the slope of the Casson plot relating the viscometric parameters of blood. In Poiseuille's flow  $\mu$  becomes the blood viscosity. Substitution of Eq. (32) into Eq. (31) and integration yields

$$Q = \frac{\pi R^4 (\Delta P/L)}{8\mu} - \frac{4\pi \tau_y^{1/2} R^{7/2} (\Delta P/L)^{1/2}}{7\sqrt{2} \mu} - \frac{2\pi \tau_y^2}{21(\Delta P/L)^3 \mu} + \frac{\pi \tau_y R^3}{3\mu} \quad (33)$$

which is valid under the assumption that the flow is steady, laminar and incompressible, and blood is homogeneous. In the above equation,  $\tau_y$  and  $\mu$  are known constants; then plots of  $Q$  vs.  $\Delta P/L$  for capillaries of various radii can be easily constructed. An example of this relationship is shown in Fig. 6.

## RESULTS AND DISCUSSION

To determine the response of the blood vessels one must solve Eqs. (8), (9), (10) and (25) under the appropriate boundary conditions. Since these equations were coupled a numerical solution using a digital computer was sought as described in an earlier paper [31].

The following constants were used in the solution:  $R_0 = 1.47$  cm,  $U = 11.9$  cm/s,  $\rho_w = 1.05$  gr/cm<sup>3</sup>,  $\rho_0 = 1.05$  gr/cm<sup>3</sup>,  $\nu = 0.038$  Stoke,  $\alpha = 0.8$  and  $\beta = 11.35 \times 10^4$  dynes/cm<sup>2</sup>. The constants  $\alpha$  and  $\beta$  are elastic constants which appear in the strain energy function  $W$ , Eq. (15). These values are reported in literature for a specimen of human aorta. The elastic constants for specimens of veins are not available, primarily because the research of determining the strain energy function in the form of Eq. (15) is relatively new.

As examples, two deceleration profiles were used in the solution: one, a linear, monotonically increasing function of time represented by  $g(t) = 7840t$  cm/s<sup>2</sup>, and a transient type (Fig. 3) which increased and decreased rapidly [32]. For both these cases, aortic pressures were calculated by utilizing a finite difference technique which involved Runge-Kutta integration procedure and Adams-Bashforth predictor-corrector method. The dimensions of the human aorta were chosen from the physiological data presented in Westerhof et al. [33]. The aortic pressures calculated for the sustaining linear deceleration profile is shown in Fig. 4. The aortic pressure in response to the transient profile of Fig. 3 is presented in Fig. 5 along with an experimentally determined pressure in the thoracic aorta of a beagle dog which was subjected to the same transient deceleration profile for comparison. The shapes of the pressure vs. time curves are nearly the same indicating satisfactory qualitative agreement. An exact quantitative agreement cannot be expected because of the anatomical and physical differences between the subjects.

The method of calculation described above for an artery can be easily extended to a vein, and the pressure difference across the capillary bed can be determined. Equation (33) represents a relationship between the flow rate and the pressure gradient in a small tube. For selected values of  $\tau_y = 0.042$  dyne/cm<sup>2</sup>,  $\mu = 0.05$  dyne-sec/cm<sup>2</sup>,  $D = 100$  microns,  $L = 2.5$  cm, the flow rate  $Q$  is computed for various pressure drops in the range  $\Delta P/L = 10 \sim 10000$  dyne/cm<sup>3</sup> and shown in Fig. 6. If the pressure of the blood pooled on the venous side is known, the effect of acceleration on the flow in microcirculation can be determined from Fig. 6. It must be noted that the flow rate indicated in Fig. 6 is for a narrow blood vessel of specific dimensions. To obtain the total blood flow one must formulate the solution on a statistical basis which includes the arterioles, venules and capillaries of various dimensions and changing rheological properties of blood.

The results presented in this paper are part of an effort to describe the cardiovascular system in terms of its physical and mechanical properties. Most investigations hither to reported have dealt with electrical analogs of the cardiovascular system in which various parameters were introduced in terms of resistances, impedances and capacitances. These electrical quantities may not truly represent the cardiovascular parameters under high g conditions, and an analysis of the cardiovascular system which is based on its original properties is therefore desirable.

## REFERENCES

- [1] Womersley, J.R., "Mathematical Analysis of the Arterial Circulation in a State of Oscillatory Motion," Wright Air Development Center, Technical Report WADC-TR-56-164, 1958.
- [2] Noordergraaf, A., "Hemodynamics," in *Biological Engineering*, Schwan, H., ed., McGraw-Hill, New York, 1969.
- [3] Taylor, M.D., "The Input Impedance of an Assembly of Randomly Branching Elastic Tubes", *Biophys. J.* Vol. 6, 1966, pp. 25-51.
- [4] Kanner, T., "Flow and Pressure in Arteries" in *Biomechanics: It's Foundations and Objectives*, Fung, Y.C. et al. eds., Prentice-Hall, Englewood Cliffs, New Jersey, 1972.
- [5] Attinger, E.O., Anne, T., Mikami, T., and Sugawara, H., "Modeling of Pressure Flow Relationships in Veins". *Hemorheology*, Copley, A., ed., McGraw-Hill, New York, 1964.
- [6] McDonald, D.A., *Blood Flow in Arteries*. E. Arnold (Publishers) Ltd., London, 1960.

- [7] Lambert, J.W., "On the Nonlinearities of Fluid Flow in Nonrigid Tubes", *J. Franklin Inst.*, Vol. 26, 1958, pp. 83-102.
- [8] Skalak, R. and Stathis, T., "A Porous Tapered Elastic Tube Model of a Vascular Bed", in *Biomechanics*, Fung, Y.C., ed., ASME Symposium, New York, New York, 1966.
- [9] Kivity, Y. and Collins, R., "Nonlinear Wave Propagation in Viscoelastic Tubes: Application to Aortic Rupture", *J. Biomechanics*, Vol. 7, 1974, pp. 67-76.
- [10] Rudinger, G., "Shock Waves in Mathematical Model of the Aorta", *J. Appl. Mech. ASME* Vol. 37, 1970, pp. 34-37.
- [11] Bergel, D.H., "The Dynamic Elastic Properties of the Arterial Wall", *J. Physiol.* Vol. 156, 1961, pp. 458-469.
- [12] Fung, Y.C., "Elasticity of Soft Tissues in Simple Elongation", *Am. J. Physiol.* Vol. 213, 1967, pp. 1532-1544.
- [13] Demiray, H., and Vito, R.P., "Large Deformation Analysis of Soft Biomaterials", *Developments in Theoretical and Applied Mechanics*, 8, Proc. 8th Southeast. Conf. on Theor. and Appl. Mech., 1976, pp. 515-522.
- [14] Prothero, J. and Burton, A.C., "The Physics of Blood Flow in Capillaries. I. The Nature of the Motion", *Biophys. J.* Vol. 1, 1961, pp. 565-579.
- [15] Whitmore, R.L. "A Theory of Blood Flow in Small Vessels", *J. Appl. Physiol.* Vol. 22, No. 4, 1967, pp. 767-771.
- [16] Gross, J.F. and Aroesty, J., "Mathematical Models of Capillary Flow: A Critical Review" *Biorheology*, Vol. 9, 1972, pp. 225-264.
- [17] Gross, J.F. and Intaglietta, M., "Effects of Morphology and Structural Properties on Microvascular Hemodynamics" Report No. P-5000, The Rand Corporation, Santa Monica, California, 1973.
- [18] Skalak, R., "Mechanics of the Microcirculation", in *Biomechanics: It's Foundations and Objectives*, Fung, Y.C. et. al. eds., Prentice Hall, Englewood Cliffs, New Jersey, 1972.
- [19] Fung, Y.C., "Microscopic Blood Vessels in the Mesentery", *Biomechanics*, Fung, Y.C., ed., ASME Symposium, New York, New York, 1966.
- [20] Burton, R.R., "Positive (+G<sub>z</sub>) Acceleration Tolerances of the Miniature Swine: Application as a Human Analog", *Aerosp. Med.*, Vol. 44, 1973, pp. 294-298.
- [21] Parkhurst, M.J., Leverett, S.D., Jr., and Shurbrooks, S.J., Jr., "Human Tolerance to High, Sustained +G<sub>z</sub> Acceleration", *Aerosp. Med.*, Vol. 43, 1972, pp. 708-712.
- [22] Leverett, S.D., Jr., Burton, R.R., Crossley, R.J., Michaelson, E.D., and Shurbrooks, S.J., Jr., "Physiologic Responses to High Sustained +G<sub>z</sub> Acceleration", USAF School of Aerospace Medicine, Tech. Rep. No. 73-21, 1973.
- [23] Peterson, D.F., Bishop, V.S., and Erickson, H.R., "Cardiovascular Changes During and Following 1-min Exposure to +G<sub>z</sub> Stress", *Aviat. Space Environ. Med.*, Vol. 46, No. 6, 1975, pp. 775-779.
- [24] Burton, R.R., and MacKenzie, W.F., "Heart Pathology Associated with Exposure to High Sustained G<sub>z</sub>", *Aviat. Space Environ. Med.*, Vol. 46, No. 10, 1975, pp. 1251-1253.
- [25] Green, A.E. and Zerna, W., *Theoretical Elasticity*, Oxford University Press, New York, London, 1968.
- [26] Klip, W., *The Foundations of Medical Physics*, University of Alabama Press, Birmingham, Alabama, 1969.
- [27] Ronse, H. (ed.) *Advanced Mechanics of Fluids*, Wiley, New York, 1959.
- [28] Burton, A.C., *Physiology and Biophysics of the Circulation*, Year Book Medical Publishers, Chicago, 1965.
- [29] Benis, A.M., "Laminar Flow of Power-law Fluids Through Narrow Three-dimensional Channels of Varying Gap. Chem. Engr. Sci., Vol. 22, 1967, pp. 805-822.
- [30] Merrill, E.W., Benis, A.M., Gilliland, E.R., Sherwood, T.K., and Salzman, E.W., "Pressure-Flow Relations of Human Blood in Hollow Fibres at Low Flow Rates", *J. Appl. Physiol.* Vol. 20, No. 5, 1965, pp. 954-967.
- [31] Avula, X.J.R. and Oestreicher, H.L., "Mathematical Model of the Cardiovascular System Under Acceleration Stress", *Aviat. Space Environ. Med.*, Vol. 49, No. 1, 1978, pp. 279-286.
- [32] Hanson, P.G., "Pressure Dynamics in Thoracic Aorta During Linear Deceleration", *J. Appl. Physiol.* Vol. 28, No. 1, 1970, pp. 23-27.
- [33] Westerhof, N., Bosman, F., Devries, C.J., and Noordergraaf, A., "Analog Studies of the Human Systemic Arterial Tree", *J. Biomech.* Vol. 2, 1969, pp. 121-143.

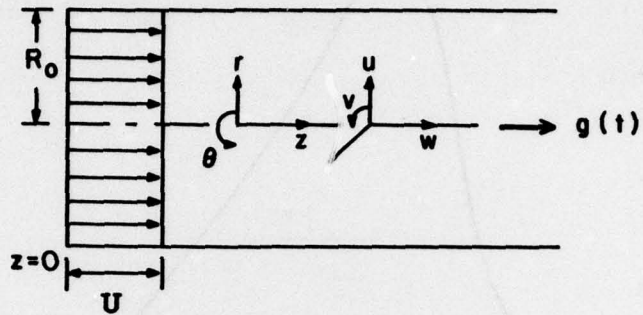

Figure 1. Definition sketch for fluid flow variables.

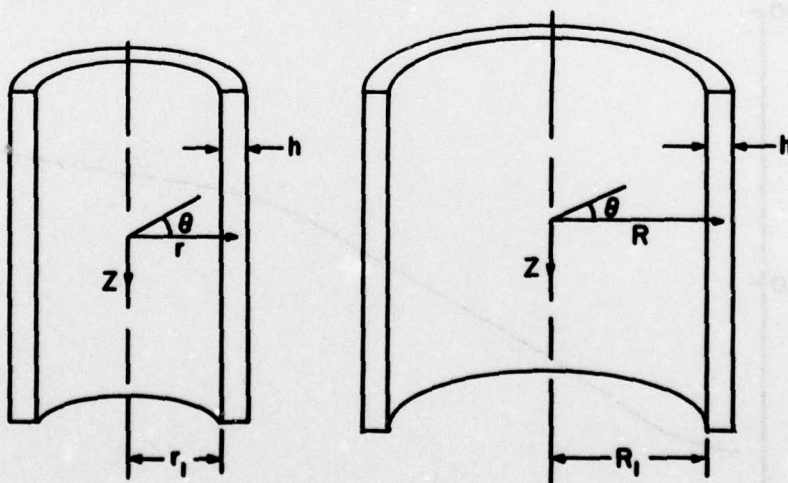

Figure 2. Geometry of the undeformed and deformed elastic tube.

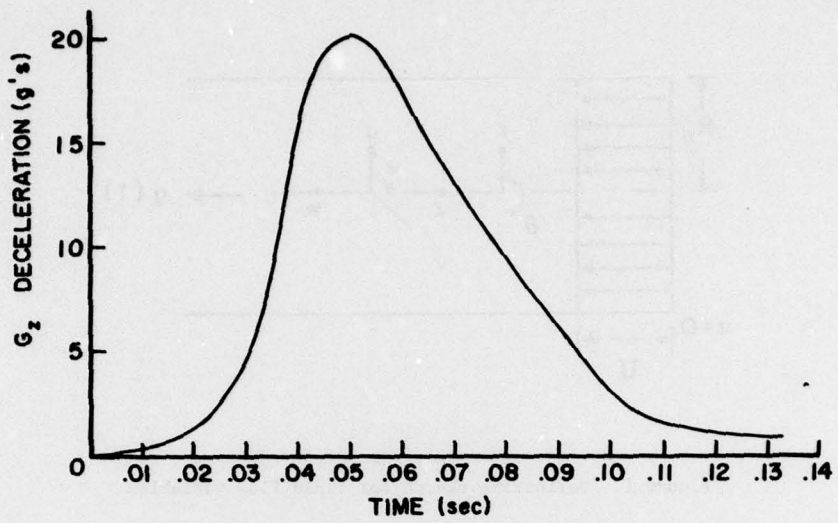

Figure 3. Deceleration function measured in the experiment by Hanson [32].

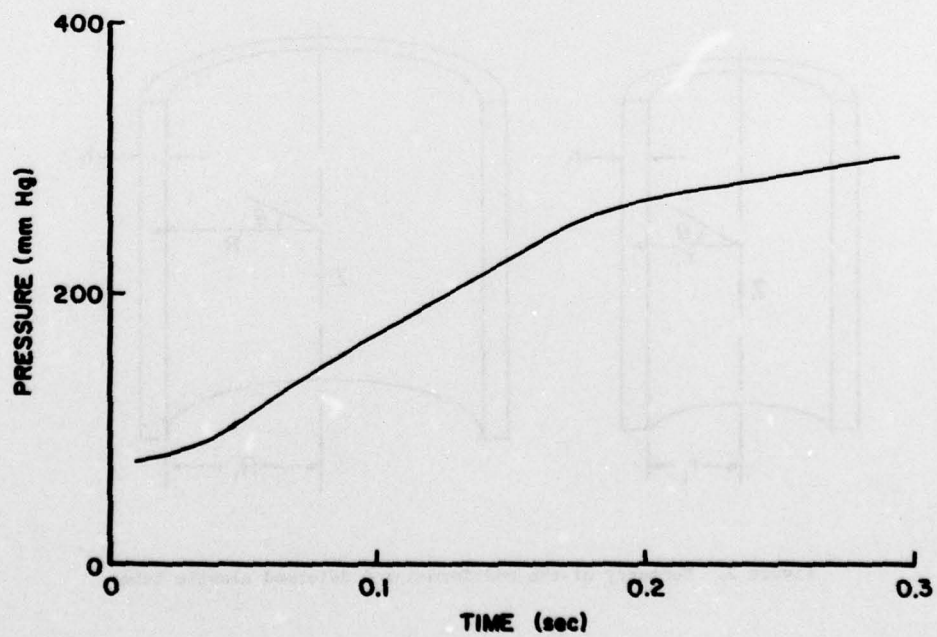

Figure 4. Calculated pressure in the aorta for the linear deceleration  $g(t) = 7840 t \text{ cm/s}^2$ .

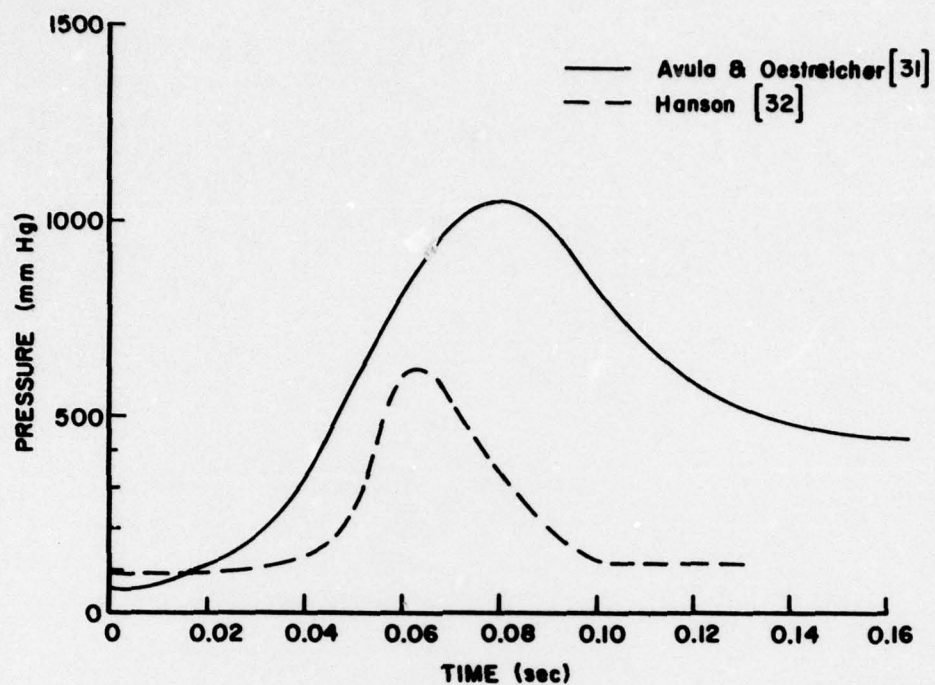

Figure 5. Comparison of theoretical and experimental pressures for the deceleration in Hanson's [32] experiment.

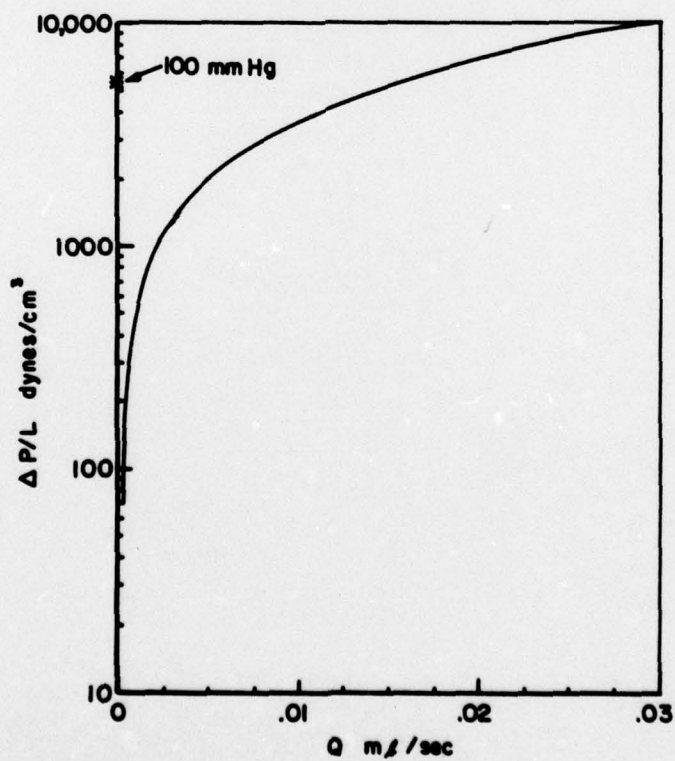

Figure 6. Pressure - Flow relationship for a narrow blood vessel (Eq. 33).