

AD-A065 614

BROWN UNIV PROVIDENCE R I DIV OF APPLIED MATHEMATICS

F/G 9/5

NEW SAW TIME INVERSION SYSTEM, (U)

1976 H MESSER, Y BAR-NESS, H GILBOA

N00014-76-C-0279

UNCLASSIFIED

NL

| OF |
AD
A065614



END
DATE
FILMED
5-79
DDC

ADA065614

DDC FILE COPY

LEVEL II

12

6 NEW SAW TIME INVERSION SYSTEM

11 1976

12 11p

10 H. /Messer, Y./Bar-Ness H. /Gilboa

H. Messer
School of Engineering
Tel Aviv University
Tel Aviv, Israel

and

Y. Bar-Ness*
Division of Applied Mathematics
Brown University
Providence, R. I. 02912

and

H. Gilboa
Ministry of Defense Armament
Development Authority
P.O. Box 2250 Haifa, Israel

15

Contract N00014-76-C-0279

DDC
RECEIVED
MAR 13 1979
C

* On sabbatical leave from the School of Engineering, Tel Aviv University.

This document has been approved for public release and sale; its distribution is unlimited.

79 02 23 008
065 300

JUB

- 0 -

NEW SAW TIME INVERSION SYSTEM

H. Messer, Y. Bar-Ness, H. Gilboa

Abstract

A new SAW time inversion system is described. It requires fewer chirp filter elements than those required with the common method of cascading two Fourier^[1] or Fresnel transformations^[2]. This new method is based on the fact that the Fourier transform of a linear F.M. signal whose envelope is modulated by a given time function has (approximately) the time inverted function as its amplitude. Theoretical discussion and some experimental results are included.

ACCESSION for		
NTIS	Wave Section	<input checked="" type="checkbox"/>
DDC	Buff. Section	<input type="checkbox"/>
UNANNOUNCED		<input type="checkbox"/>
JUSTIFICATION		
BY		
DISTRIBUTION/AVAILABILITY CODES		
Dist.		
A		

Introduction

Time inversion systems could be very useful for signal processing applications in different communication problems. Real time adaptive matched filters can simply be obtained by convolving (using SAW convolvers) the given signal and its time inverted version. The crosscorrelation function between two signals can be obtained using such a convolver together with a time inversion of one of these signals. Such a correlator can be useful, for example, in many applications of adaptive arrays.

Applying two identical inverse chirp transform systems^[1] to a real time signal will result in an output which is the time inverted replica of the input. Implementation of this idea, using chirp elements would require at least four chirp filters. Similarly using Fresnel transform^[2] we need three chirp elements.

In this paper we present a new and simpler method of time inversion, which require still fewer chirp elements.

Principle of Operation of the New Time Inversion System

The basic configuration of the new time inversion system is given in Figure 1. Except for the difference in chirp filter slopes this system resembles the regular

MCM (multiplication-convolution-multiplication) chirp transform system.

To demonstrate the operation of the system it will be assumed that the signals (the impulse response of the chirp filters) are of an ideal all pass baseband type, $e^{\pm j\mu t^2}$ [3].

Let

$$f(t) = r(t)e^{-j\mu t^2}, \quad (1)$$

be a linear F.M. signal whose envelope is modulated by a given function $r(t)$. Its Fourier transform is given by

$$F(\omega) = e^{\frac{j\omega^2}{4\mu}} \int_{-\infty}^{+\infty} r(t) e^{-j\mu(t + \frac{\omega}{2\mu})^2} dt. \quad (2)$$

This integral, however, cannot be evaluated in general. Nevertheless when $r(t)$ is slowly varying, it is possible to find a simple approximant to equation (2)^[4]. This is based on the following approximate limit expression for the delta function,

$$\delta(t) = \lim_{\mu \rightarrow \infty} \sqrt{\frac{\pm\mu}{j\pi}} e^{\pm j\mu t^2} \quad (3)$$

using this in equation (2) we have

$$F(\omega) \simeq \sqrt{\frac{j\pi}{-\mu}} e^{\frac{j\omega^2}{4\mu}} r\left(-\frac{\omega}{2\mu}\right), \quad (4)$$

and with the chirp transform, $\omega = 2\mu t$, we get

$$F(2\mu t) \simeq \sqrt{\frac{-j\pi}{\mu}} e^{\frac{j(2\mu t)^2}{4\mu}} r(-t). \quad (5)$$

From Figure 1 we obtain after simple manipulation

$$y(t) = e^{j\mu t^2} \int_{-\infty}^{+\infty} r(\tau) e^{-j\mu \tau^2} e^{-j2\mu \tau t} d\tau$$

and by equation (1) and the definition of the chirp transform this becomes,

$$y(t) = e^{j\mu t^2} F(2\mu t). \quad (6)$$

Finally, substituting equation (5) into equation (6) yields

$$y(t) \simeq \sqrt{\frac{-j\pi}{\mu}} e^{j2\mu t^2} r(-t). \quad (7)$$

The accuracy of this approximation depends, of course, on how large μ is. In practical systems, μ

is usually large enough $\mu = \frac{B}{2T}$, where B is the filter bandwidth and T is the time duration of its impulse response. For saw chirp filters B is in MHz and T is in microseconds, so that μ is of the order of 10^{12} .

Discussion and Experimental Results

Non-ideal saw chirp filter have a finite bandwidth B and an impulse response of finite duration T . Therefore just as for the MCM configuration of a chirp transform^[3], the system bandwidth (i.e., the maximum signal bandwidth that can be processed by the system) is; $B_s = B_2 - B_1$ where $B_1 = 4\mu T_1$ and $B_2 = 2\mu T_2$. Furthermore, it can be shown^{[3],[5],[6]} that the integral of equation (6) gives the Fourier transform of $f(t)$ if $-\frac{1}{2}(T_2 - T_1) \leq t \leq \frac{1}{2}(T_2 - T_1)$ where $T_2 > T_1$. Notice that the system duration T_s (the maximum signal duration that can be processed by the system) equals T_1 . Thus, letting $T_1 = \alpha T_2$, $\alpha < 1$ we have

$$B_s T_s = 2\mu(1-2\alpha)\alpha T_2^2. \quad (8)$$

The maximum system time-bandwidth is obtained for $\alpha = \frac{1}{4}$, and thus the optimal design is obtained with $T_1 = \frac{1}{4} T_2$, $B_1 = \frac{1}{2} B_2$ and $B_s = \frac{1}{2} B_2$ and $T_s = \frac{1}{4} T_2$.

Notice that these results are different from those obtained for MCM chirp transform system. For the latter $\alpha = 1/2$ was required for maximum time bandwidth.

The experimental set-up shown in Figure 2 was used to test the principle idea of the new time inversion system. Squarer element followed by bandpass filter is used to obtain the double chirp slope. Figures (3a) and (3b) present measured input and output of the time inversion system. The lower traces in these figures represent the input signal, while the upper include the output signal after an r.f. detector.

Conclusion

Using a limit expression for the delta functions (equation (3)), we proved that the amplitude of the Fourier transform (equation (4)) of a linear F.M. signal modulated by a given function $r(t)$, (equation (1)) is the time inverted function $r(-t)$. Using this we presented a new saw time inversion system that require for its implementation less chirp elements than the systems based on using inverse chirp^[1] or Fresnel transforms^[2].

Acknowledgement

The authors would like to thank Dr. N. Lebanon from Tel Aviv University for his help in the course of this research. The second author would also like to thank the Office of Naval Research (N0014-76-C-0279-P0002) for the partial support he received while visiting Brown University.

References

- [1] Nudd, G.R. and Otto, O.W., "Chirp signal processing using acoustic surface wave filters", Proc. 1975 IEEE Ultrasonic Symposium, IEEE Cat. No. 75, 944-450.
- [2] Arsenault, D.R. and Das, P., "Saw Fresnel transform devices and their applications", Proc. 1977 IEEE Ultrasonic Symposium, IEEE Cat. No. 77 CH 1264-1SU.
- [3] Atzeni, C., "Saw signal transform techniques", Wave Electronics, Vol. 2, 1976, pp. 238-265.
- [4] Papoulis A., Signal Analysis, McGraw-Hill, 1977.
- [5] Hays, R.M., Shreve, W.R. and Bell, D.T., Jr., "Surface wave transform adaptable processor systems", Proc. 1975 IEEE Ultrasonic Symposium, IEEE Cat No. 75, 994-450.
- [6] Otto, O.W., "The chirp transform signal processor", Proc. 1976 IEEE Ultrasonic Symposium, IEEE Cat. No. 76 CH 1120-5SU.

Legends

- Figure 1 The basic configuration of the time inversion system
- Figure 2 Experimental set-up used for testing the principle idea of the time inversion system.
- Figure 3 Experimental Results. In both photos the lower traces represent input signal and the upper trace the outputs

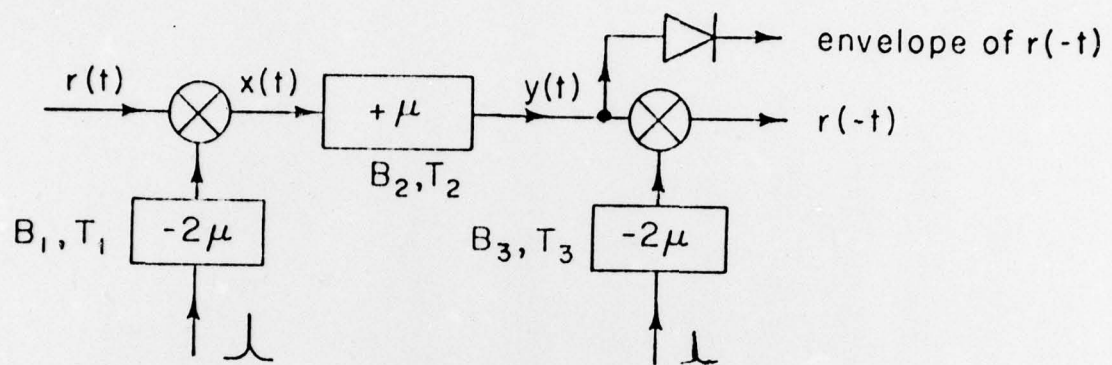

FIG. 1

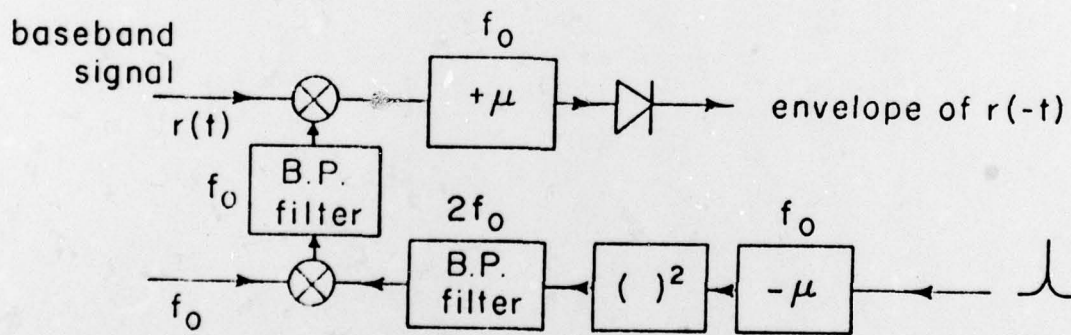

FIG. 2

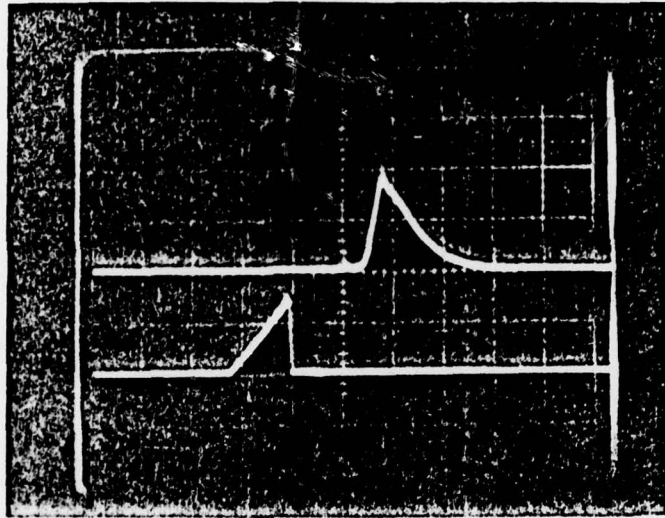

FIG. 3a

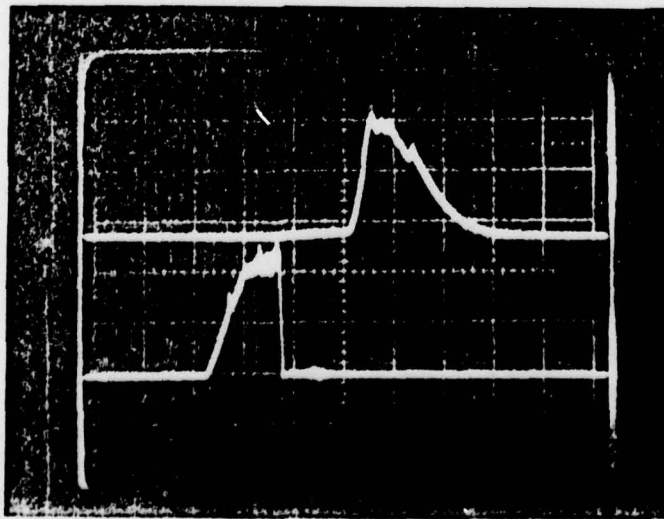

FIG. 3b