

AD-A065 659

CONSTRUCTION ENGINEERING RESEARCH LAB (ARMY) CHAMPAIN--ETC F/6 13/13  
A FAMILY OF COMPONENTS FOR THE WOOD PANELIZED PREFABRICATED BUI--ETC(U)  
JAN 79 A M KAO, T M WHITESIDE  
CERL-SR-M-255

UNCLASSIFIED

NL

1 OF 1  
AD  
A065659



END  
DATE  
FILMED  
5-79  
DDC

construction  
engineering  
research  
laboratory



United States Army  
Corps of Engineers  
...Serving the Army  
...Serving the Nation

*B.S. 12*

SPECIAL REPORT M-255  
January 1979

Expedient Structural Systems for Theater of Operations

A FAMILY OF COMPONENTS FOR THE WOOD  
PANELIZED PREFABRICATED BUILDING SYSTEM

**LEVEL**

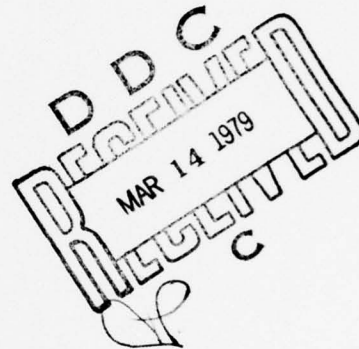

AD A0 65659

DDC FILE COPY

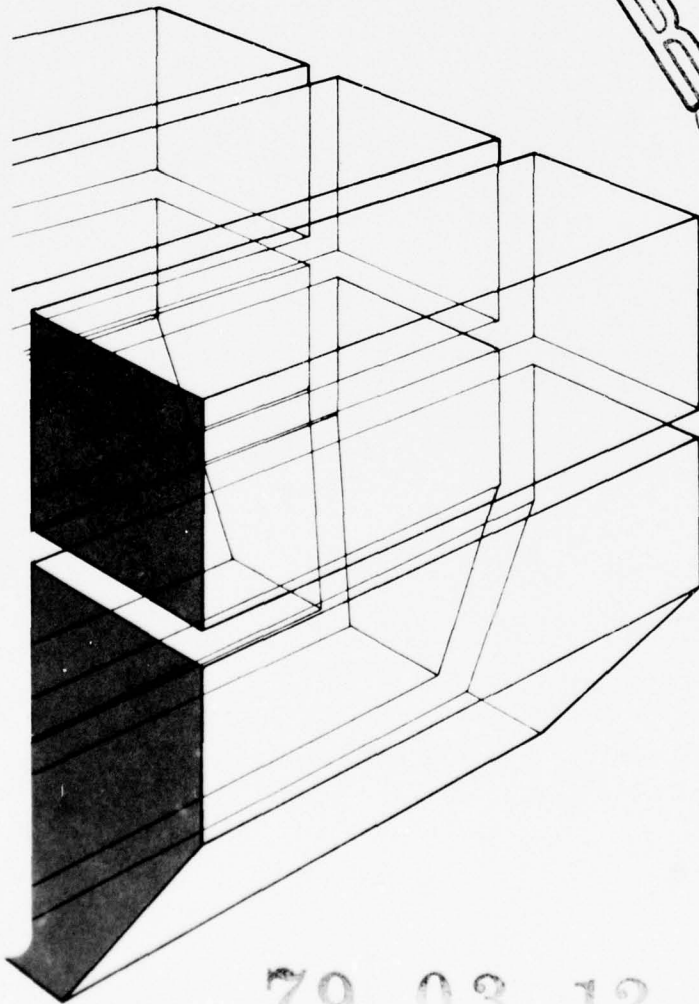

by  
A. M. Kao  
T. M. Whiteside



79 03 12 13 6

The contents of this report are not to be used for advertising, publication, or promotional purposes. Citation of trade names does not constitute an official indorsement or approval of the use of such commercial products. The findings of this report are not to be construed as an official Department of the Army position, unless so designated by other authorized documents.

*DESTROY THIS REPORT WHEN IT IS NO LONGER NEEDED  
DO NOT RETURN IT TO THE ORIGINATOR*

REPORT DOCUMENTATION PAGE		READ INSTRUCTIONS BEFORE COMPLETING FORM	
1. REPORT NUMBER 24 CERL-SR-M-255	2. GOVT ACCESSION NO.	3. RECIPIENT'S CATALOG NUMBER 9	
4. TITLE (and Subtitle) 6 A FAMILY OF COMPONENTS FOR THE WOOD PANELIZED PREFABRICATED BUILDING SYSTEM		5. TYPE OF REPORT & PERIOD COVERED SPECIAL rept.	
7. AUTHOR(S) 10 A. M. Kao T. M. Whiteside		6. PERFORMING ORG. REPORT NUMBER	
9. PERFORMING ORGANIZATION NAME AND ADDRESS U.S. ARMY CONSTRUCTION ENGINEERING RESEARCH LABORATORY P.O. Box 4005, Champaign, IL 61820		8. CONTRACT OR GRANT NUMBER(s)	
11. CONTROLLING OFFICE NAME AND ADDRESS 12/69a		10. PROGRAM ELEMENT, PROJECT, TASK AREA & WORK UNIT NUMBERS 24 4A763734DT08-06-002	
		12. REPORT DATE 11 January 1979 17 06	
14. MONITORING AGENCY NAME & ADDRESS (if different from Controlling Office)		13. NUMBER OF PAGES 65	
		15. SECURITY CLASS. (of this report) Unclassified	
		15a. DECLASSIFICATION/DOWNGRADING SCHEDULE	
16. DISTRIBUTION STATEMENT (of this Report)  Approved for public release; distribution unlimited.			
17. DISTRIBUTION STATEMENT (of the abstract entered in Block 20, if different from Report)			
18. SUPPLEMENTARY NOTES  Copies are obtainable from National Technical Information Service Springfield, VA 22151			
19. KEY WORDS (Continue on reverse side if necessary and identify by block number)			
20. ABSTRACT (Continue on reverse side if necessary and identify by block number)  This report presents the design of a prefabricated, panelized wood building system capable of housing a large percentage of facilities required in the Theater of Operations. Configurations of the building structural system include 24-, 36-, and 48-ft (7.3-, 10.9-, and 14.6-m) widths and 8- and 12-ft (2.4- and 3.7-m) eave heights. Optional components include raised wood and concrete floors as well as modifications for temperate, tropical, and desert climates.			

405 279

20B

Block 20 continued.

This report also presents the results of a field test on a foam/wood panelized building system conducted at Fort Rucker using military personnel. The result indicates the competitiveness of the system in comparison with AFCS Facility 3403; up to 40 percent reduction in labor requirements can be reached.



UNCLASSIFIED

SECURITY CLASSIFICATION OF THIS PAGE(When Data Entered)

FOREWORD

The design development of this building system was funded by the Directorate of Military Programs, Office of the Chief of Engineers (OCE), under Project 4A763734DT08, "Military Construction and Field Engineering Development"; Task 06, "Base Development"; Work Unit 002, "Expedient Structural Systems for Theater of Operations." The OCE Technical Monitor was Mr. E. McWhite.

The work was performed by the Engineering and Materials Division, U.S. Army Construction Engineering Research Laboratory (CERL). Dr. A. M. Kao was the Principal Investigator. Appreciation is extended to Mr. H. S. Chun for work performed in the structural analysis of the building system.

Appreciation is extended to MAJ G. Pincince, CPT P. Lisowski, and members of the 46th Engineer Combat Battalion (Heavy) for performing a field test on foam/wood panelized building systems at Fort Rucker, AL.

COL J. E. Hays is Commander and Director of CERL, and Dr. L. R. Shaffer is Technical Director. Dr. G. R. Williamson is Chief of EM.

ACCESSION for	
NTIS	Write Section <input checked="" type="checkbox"/>
DDC	Buff Section <input type="checkbox"/>
UNANNOUNCED	<input type="checkbox"/>
JUSTIFICATION _____	
BY _____	
DISTRIBUTION/AVAILABILITY CODES _____	
Dist:	_____
A	

3 79 08 12 138

CONTENTS

DD FORM 1473	1
FOREWORD	3
LIST OF FIGURES AND TABLES	5
1 INTRODUCTION. . . . .	9
Background	
Objective	
Approach	
Mode of Technology Transfer	
2 DEVELOPMENT OF THE BUILDING SYSTEM DESIGN . . . . .	11
Design Criteria	
Design Evolution	
3 BUILDING SYSTEM DESCRIPTION . . . . .	18
Structural Concepts	
Component Descriptions	
Climatic Options	
System Function	
4 CONCLUSIONS AND RECOMMENDATIONS . . . . .	47
APPENDIX: Field Experiment on a Prefabricated Panelized Foam/Wood Structure at Fort Rucker, AL	48
REFERENCES. . . . .	65
DISTRIBUTION	

## FIGURES

<u>Number</u>		<u>Page</u>
1	Structural Concept	19
2	Building System for 24- and 36-ft (7.3- and 10.9-m) Widths	20
3	Building System for 48-ft (14.6-m) Widths	21
4	Cross-Sectional Space for Connections	22
5	Method by Which Components Interlock	23
6	Building System Components	24
7	Concrete Floor	25
8	Raised Wood Floor	27
9	Wall Columns	28
10	Wall Panels	29
11	Wall Headers	30
12	Trusses for 24- and 36-ft (7.3- and 10.9-m) Buildings	31
13	Truss for 48-ft (14.6-m) Building	33
14	Truss Connection Methods for 48-ft (14.6-m) Building	34
15	Floor and Roof Panels	35
16	Building Endwall for 8-ft (2.4-m) Eave Height	36
17	Building Endwall for 12-ft (3.7-m) Eave Height	37
18	Endwall Sections	38
19	Climatic Options	41
20	Wall Sections for Buildings in Temperate Climates	43

FIGURES (cont'd)

		<u>Page</u>
21	Wall Sections for Tropical Buildings	44
22	Wall Sections for Desert Buildings	45
23	Expansion Modules	46
A1	Completed Fort Belvoir Building	52
A2	Completed Fort Rucker Building	52
A3	Isometric Drawing of the Panelized Building System	53
A4	Foundation Bent	54
A5	Wall Panels	55
A6	Roof Panels Being Installed	56
A7	Completed Building Interior Before Finishing	57
A8	Interior Walls Covered with 5/8-in. (1.59-cm) Gypsum Boards	58
A9	Completed Building Interior	59
A10	Exterior View Showing Sloping Grade	60
A11	Completed Stairway at Rear of Building	61

## TABLES

<u>Number</u>		<u>Page</u>
1	Environmental Design Loads Recommended by AFCS	14
2	Recommended AFCS Lumber and Plywood Design Criteria	15
3	Comparison of AFCS and CONUS Lumber and Plywood Design Criteria	16
4	Climatic Options	40
A1	Comparison of Construction Cost, Labor, and Logistic Data Between Fort Belvoir Building and AFCS Facility 3403	62
A2	Summary of Construction Cost and Labor Data	62

## A FAMILY OF COMPONENTS FOR THE WOOD PANELIZED PREFABRICATED BUILDING SYSTEM

### 1 INTRODUCTION

#### Background

The need for improved construction techniques which are responsive to user and functional requirements in a Theater of Operations (TO) has been recognized by the Corps of Engineers (CE). Shelter constructed to house military activities has traditionally been provided by either of two methods. In one method, pre-engineered, relocatable buildings are prefabricated outside the TO and shipped to the site where they are needed. Because initial cost of these buildings is high, they must be reused in other locations if they are to be cost effective. Unless such buildings have been stockpiled, they may not be available in the desired quantities because of the long lead times necessary to produce them. The shipping volume may be high unless they are shipped in a knocked-down or panelized form. The major benefit of these buildings as compared to other types is the reduced labor required for their erection in the TO.

The other method of providing shelter is to prefabricate the components in the TO from material either acquired locally or shipped in. Prefabrication and panelization are improvements over stick-built construction from a labor standpoint. Also, because a relatively small number of simplified components are used, it is feasible for non-CE troops to assume responsibility for erecting the structures. The volume of material which must be shipped in is reduced from that required for relocatable buildings. Finally, material and labor costs can be controlled as austerity, which is dependent on the desired standard of construction, is enforced.

This report is directly concerned with the second method--the design of a building system constructed from components panelized and prefabricated from local or shipped-in materials to meet facility and user needs in the TO.

#### Objective

The technical objective of this study is to develop an expedient and economical structural system that can be used to construct a large percentage of the facilities required in the TO. The purpose of this report is to describe the structural concept chosen to meet this objective and its application as part of a specific building system.

### Approach

The design of the building system described in this report was based on computerized structural analyses. Once developed, the structural concept was refined through field testing. Several field tests have been conducted to date on a building with a 24-ft (7.3-m) width. The design presented in this report shows how this concept is expanded to buildings of increased width and eave height.

### Mode of Technology Transfer

It is anticipated that this building system will impact on AFCS through Army Technical Manuals 5-301, 5-302, and 5-303.<sup>1</sup> The results of the project will be transferred to users through field demonstrations, reports, and the Army Training Literature Program.

---

<sup>1</sup> Department of the Army, Army Facilities Components System - Planning, TM5-301; Army Facilities Components System - Design, TM5-302; Army Facilities Components System - Logistic Data and BITTs of Materials, TM5-303, 1973.

## 2 DEVELOPMENT OF THE BUILDING SYSTEM DESIGN

### Design Criteria

Design criteria for the wood prefabricated panelized building system described in this report were derived from the principles of construction in the TO found in TM5-333.<sup>2</sup> Those principles include:

1. Speed of construction through the standardization and simplification of building components and construction activities, the incorporation of minimum essentials (maximum austerity), minimum life expectancy, and phased construction
2. Economy of construction in the use of materials, equipment, and personnel
3. Flexibility in meeting changing TO conditions.

The criteria drawn from these principles of construction to guide the development of the building system are:

1. Maximize rapidity of fabrication and erection of components
2. Maximize simplicity of fabrication and erection of components
3. Design for temporary standard of construction
4. Design for phased construction
5. Minimize material cost
6. Minimize equipment requirements and skills
7. Minimize construction skills
8. Minimize labor effort
9. Minimize weight and volume logistical requirements
10. Minimize total construction cost for material and labor
11. Maintain a high degree of flexibility to meet operational conditions

---

<sup>2</sup> Headquarters, Department of the Army, Construction Management, TM5-333 (February 1972).

In addition, the technical objective suggests further criteria related to functional requirements:

12. Provide a group of common cladding components which are usable without modification for each building configuration in the system

13. Provide sufficient space and floor-load capacity to house administrative, supply, barracks, mess, hospital, warehouse, and certain maintenance functions

14. Provide climatic options

15. Base the structural system for all configurations on one general concept

Finally, two additional criteria were based on AFCS recommendations:

16. Incorporate the recommended material design properties for lumber and plywood

17. Take into account in the design the recommended environmental and live loads as well as loading combinations.

#### Design Evolution

This project has comprised two general areas of study. One focused on experimentation with the use of polyurethane foam and dimensioned lumber in various combinations. The other, which grew in importance as the use of foam materials was eliminated, concentrated on the use of plywood in place of foam as a cladding and structural material in combination with lumber.

A parallel study explored several other building systems incorporating the use of cardboard, metal pipe, and several different types of panels. Those efforts are discussed in a separate publication.<sup>3</sup> The wood building system was chosen for further development after evaluating and comparing all the systems studied.

Wood prefabricated panelized buildings have been field tested at two sites: Fort Rucker and Fort Belvoir. Both field tests were conducted using a building 24 ft (7.3 m) wide. Results of the Fort Rucker

---

<sup>3</sup> A. M. Kao and J. Cook, Alternative Theater of Operations Building Systems: Progress Report, Special Report C-80/ADA042312 (Construction Engineering Research Laboratory [CERL], 1977).

test are documented in the Appendix; the Fort Belvoir test and earlier efforts have been published in other reports.<sup>4</sup>

As the structural concept and erection methods were refined, work began in early 1977 on the development of a system of building using these methods but with increased widths and eave heights for greater efficiency. Desirable building widths, heights, and expansion modules were determined on the basis of (1) anticipated capabilities of the structural concept and materials to carry required loads, (2) recommended building configurations from the PLAST study,<sup>5</sup> and (3) modular dimensions imposed by the use of standard 4-ft by 8-ft (1.2-m by 2.4-m) plywood sheets. The configurations selected included structures with the following dimensions:

(1) Widths: 24, 36, and 48 ft (7.3, 10.9, and 14.6 m).

(2) Clearspans: 24 and 36 ft (7.3 and 10.9 m).

(3) Baysizes:

(a) 24- and 36-ft (7.3- and 10.9-m) widths, clearspan, by the desired number of 8-ft (2.4-m) expansion modules.

(b) 48 ft (14.6 m) width with a 24-ft span by 24-ft (7.3-m by 7.3-m) expansion module.

(4) Eave heights: 8 and 12 ft (2.4 and 3.7 m).

Buildings of larger widths were not considered as they were not compatible with the structural concept developed.

Recommendations on material design criteria and on environmental and floor live loads from the current AFCS contract effort to develop a panelized building were incorporated. The loading criteria are shown in Table 1 and the material design criteria are listed in Table 2. The

---

<sup>4</sup> A. M. Kao, T. M. Whiteside, A. Smith, and R. L. Trent, Prefabricated Expandable Foam/Wood Structure for the Theater of Operations, Interim Report C-45/ADA J44991 (CERL 1977); R. L. Trent, T. M. Whiteside, and J. Robertus, Field Experiment on a Prefabricated Expandable Foam/Wood Structure, Interim Interim Report C-50/ADA032726 (CERL, 1976); and R. L. Trent, T. M. Whiteside, and J. Robertus, Erection Procedures for Prefabricated Expandable Foam/Wood Structure, Technical Report C-52/ADA027382 (CERL, 1976).

<sup>5</sup> U.S. Army Engineer School, Pre-engineered Logistic and Administrative Structures (PLAST) (16 August 1973).

CERL design was based on a standard for temporary construction. As a result, the loads defined by AFCS for Standard 2 temporary structures (simple prefabricated wood buildings with a design life of up to 5 years) were used in the structural analysis. However, CERL personnel felt that the snow loading was excessively high, particularly when reductions were not permitted subject to roof slope.

Table 1  
Environmental Design Loads Recommended by AFCS

	Temperature/Frigid	Tropical/Desert
Wind Load (mi/hr)	50 (80.5 km/hr)	50 (80.5 km/hr)
Snow Load (psf)	40 (195.2 kg/m <sup>2</sup> )	--
Floor Live Load (psf)	100 (488 kg/m <sup>2</sup> )	100 (488 kg/m <sup>2</sup> )

Material design criteria values were somewhat more critical. The criteria specified by AFCS were drawn from an earlier CERL report by R. H. Heidersbach.<sup>6</sup> The criteria for beams and stringers and for plywood, as given in Table 2, were used for the CERL structural analysis. Table 3 compares the AFCS criteria with those commonly applied in civilian design CONUS. The comparison shows that the allowable stresses specified by AFCS are substantially lower.

To derive the reduced values given in Table 2, Heidersbach first determined which lumber species were available through the AFCS logistical system. From this list he selected the species with the controlling (lowest) allowable stresses. The allowable stress for that species then defined the criteria for each structural application after being adjusted for duration of loading and the removal of safety factors. The rationale for this procedure was to insure that material shipped to the TO would meet minimum structural criteria, given indeterminant stress grading and the possibility of deterioration caused by shipment and storage.

The controlling species selected for beams and stringers were northern white cedar (for extreme fiber in bending, F<sub>b</sub>, compression parallel to grain, F<sub>c</sub>, and the modulus of elasticity, E) and balsam fir (for the remaining allowable stresses). Heidersbach's process produces a very conservative design since cedar and balsam fir represent *only* 1.5

<sup>6</sup> R. H. Heidersbach, Jr., Wood Design Parameters for Theater of Operations Applications, Technical Report M-80/AD#780800 (CERL, 1974).

Table 2  
Recommended AFCS Lumber and Plywood Design Criteria

APPLICATION SIZE CLASSIFI- CATION and GRADE(S)	ALLOWABLE UNIT STRESSES IN PSI*						
	Extreme Fiber in Bending $F_b$	Tension Parallel to Grain $F_t$	Horizontal Shear $F_v$	Compression Perpendicular to Grain $F_c$	Compression Parallel to Grain $F_c$	Modulus of Elasticity $E$	Rolling Shear in Plane of Plies $F_b$
<u>Light structural framing</u>							
No. 2 or Standard	325	200	60	170	445	528,000	-
No. 1 or Construction	600	350	60	170	555	528,000	-
<u>Structural joists and planks</u>							
No. 2	875	560	65	170	630	700,000	-
No. 1	1065	720	65	170	740	800,000	-
<u>Beam &amp; stringers</u>							
No. 1	940	595	60	170	550	700,000	-
Select Structural	1125	750	60	170	660	700,000	-
<u>Post &amp; timbers</u>							
No. 1	845	560	60	170	605	700,000	-
Select structural	1060	720	60	170	715	700,000	-
Plywood	800	720	130	120	550	800,000	35

\* Metric conversion factor = 1 psi = 6.894 757 x 10<sup>+3</sup> Pa

Table 3

Comparison of AFCS and CONUS Lumber and Plywood Design Criteria

APPLICATION SIZE CLASSIFI- CATION and GRADE(S)	ALLOWABLE UNIT STRESSES IN PSI+						
	Extreme Fiber in Bending to Parallel to Grain $F_b$	Tension Parallel to Grain $F_t$	Horizontal Shear $F_v$	Compression Perpendicular to Grain $F_c$	Compression Parallel to Grain $F_c$	Modulus of Elasticity $E$	Rolling Shear in Plane of Plies $F_b$
<u>Beam &amp; Stringers</u>							
AFCS*	940	595	60	170	550	700,000	-
Civilian**	750-1300	475-850	55-110	170-425	500-1050	700,000-1,600,000	-
<u>Plywood</u>							
AFCS*	800	725	130	120	550	800,000	35
Civilian**	1650	1650	250	1100	1540	1,800,000	

Sources:

- \*R. H. Heidersbach, Jr., Wood Design Parameters for Theater of Operations Applications, Technical Report M-80/AD780800 (CERL, 1974).
- \*\*American Plywood Association, Plywood Design Specification, 1974.
- + Metric Conversion Factor: 1 psi = 6.897 757 x 10<sup>5</sup> Pa.

and 3.1 percent, respectively, of the standing timber volume in CONUS of those lumber species available through AFCS for beams and stringers.<sup>7</sup> There is a strong probability that species with higher allowable stresses would be available in the TO.

In any case, the AFCS allowable stresses for beams, stringers, and plywood were used to the extent possible in the CERL analysis. In several cases when the structural members designed using AFCS criteria were felt to be overly conservative, they were modified and redesigned by checking against the civilian codes. The STRESS computer program was used to analyze the frames and structural concept described in Chapter 3.<sup>8</sup>

Criteria for the CERL building system were established to provide designs for three climates--temperate, tropical, and desert. The results of a CERL research project on vertical construction in desert and tropic regions suggested that there was enough difference in tropical and desert climates to justify separate designs or options for each climate. Recommendations and conclusions from that project have been incorporated into the development of the CERL building system.<sup>9</sup>

---

<sup>7</sup> American Society for Testing and Materials "Standard Methods for Establishing Clear Wood Strength Values," Annual Book of ASTM Standards, D2555-76 (1976).

<sup>8</sup> The Structural Engineering Systems Solver Users Manual (Department of Civil Engineering, University of Illinois, Urbana, IL, 1968).

<sup>9</sup> A. Kao and J. Cook, Preliminary Design and Construction Guidelines for Vertical Construction in Desert and Tropical Theaters of Operations, Interim Report C-74/ADA032124 (CERL, 1976).

### 3 BUILDING SYSTEM DESCRIPTION

#### Structural Concepts

The CERL building system is based on the use of wall columns and a pitched roof truss joined by rigid connections (Figure 1). A center column is used to reduce the size and weight of the truss for the 48-ft-wide (14.6-m-wide) building. General details for the 24- and 36-ft (7.3- and 10.9-m) buildings are shown in Figure 2. Components include a raised wood or concrete floor system, wall columns, clearspan trusses, a wall header, roof panels, and wall panels. Components for the 48-ft (14.6-m) building, shown in Figure 3, include a raised wood or concrete floor system, wall and center span columns, a wall header, a ridge box beam, truss halves, roof panels, and wall panels.

Structural and panel components are connected by means of a 3/4-in. (1.9-cm) space at the centerline of each 8-ft (2.4-m) increment in length. Plywood, dimensioned lumber, or steel connectors fit into this space, which extends completely around the building in cross section as shown in Figure 4. Each component fits into or interlocks with adjacent components and is bolted or nailed in place. Figures 5a and 5b show how the wood raised floor system, laminated girder, and wall column are connected with a metal strap. Figures 5c and 5d show how the center truss gusset fits into the wall column at the eave. Figures 5e and 5f show how roof panels are connected to the roof truss through a plywood web at the panel ends. Floor panels are installed in a similar fashion. When a concrete foundation is desired, a metal plate anchored to the foundation fits up into the 3/4-in. (1.9-cm) space in the wall column.

#### Component Concepts

The array of individual structural and cladding components is shown in Figure 6. These components are discussed below.

##### *Floor System*

1. The concrete strip foundation and a slab on grade (Figure 7) are used together, or the strip foundation can be used alone in phased construction. The slab thickness may be 2, 4, or 6 in. (5.1, 10.2, or 15.3 cm), depending on the anticipated floor loads. A metal connector is attached to the foundation with an anchor bolt which also passes through a sill plate as a connection for the wall column.

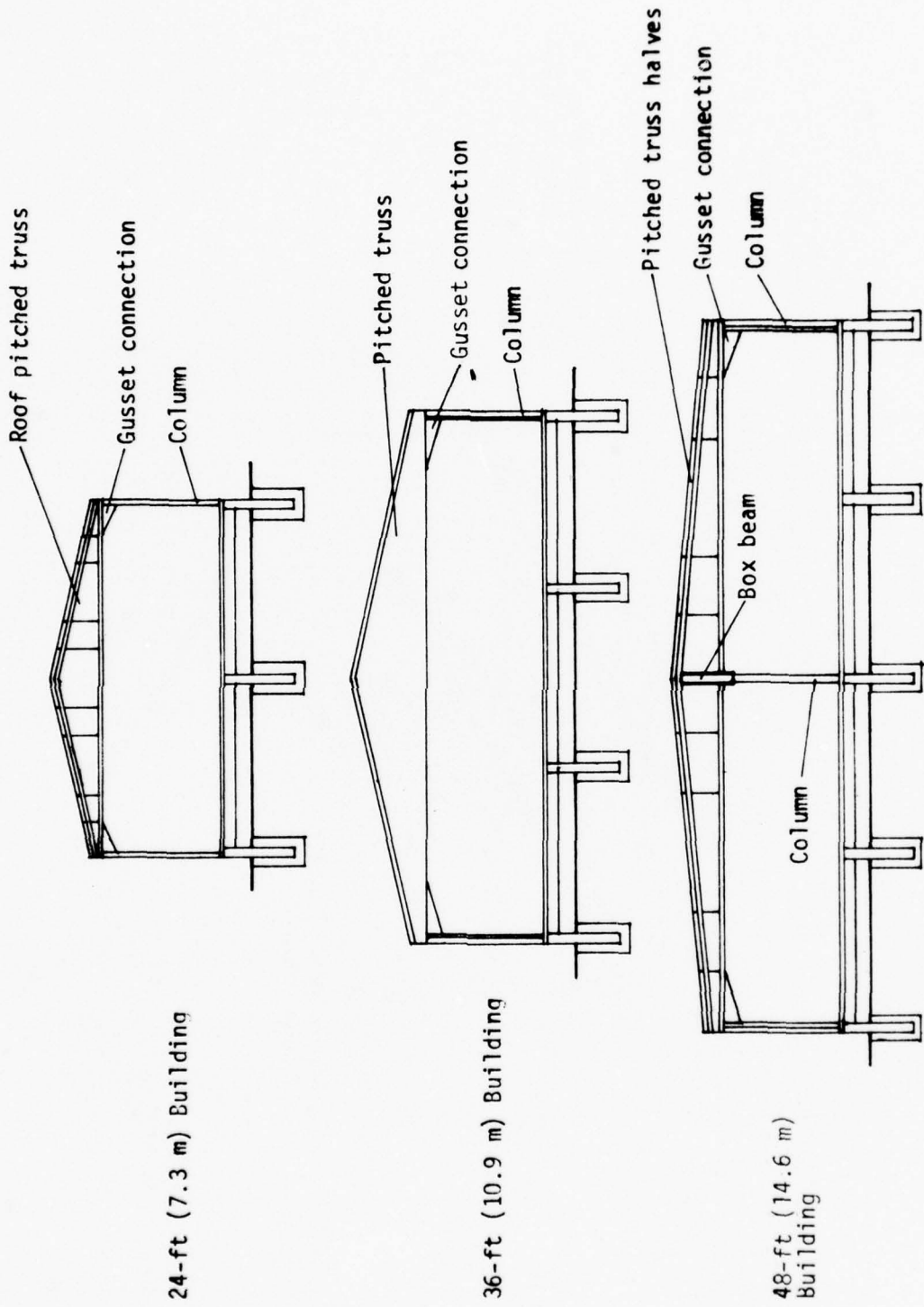

Figure 1. Structural concept.

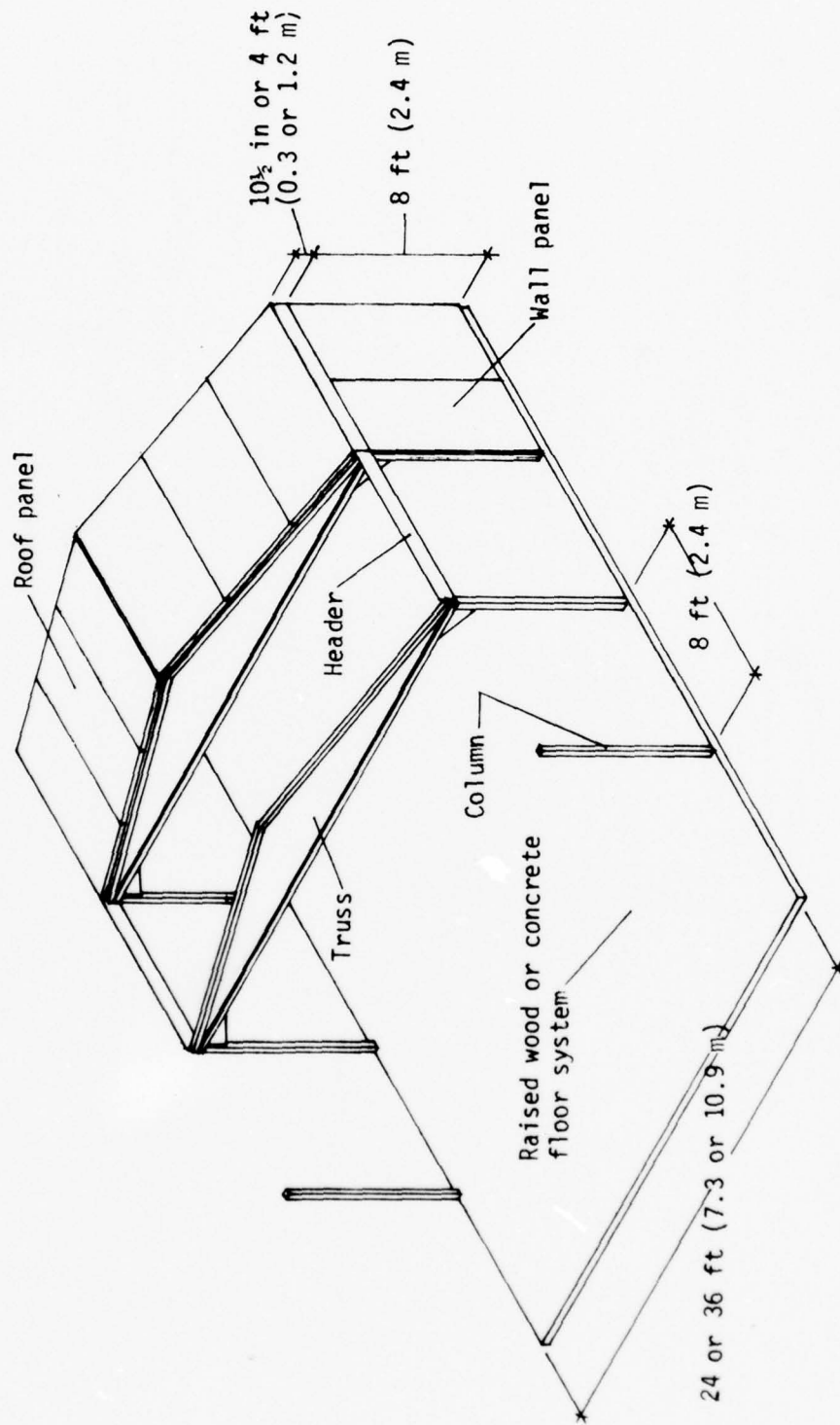

Figure 2. Building system for 24- and 36-ft (7.3- and 10.9-m) widths.

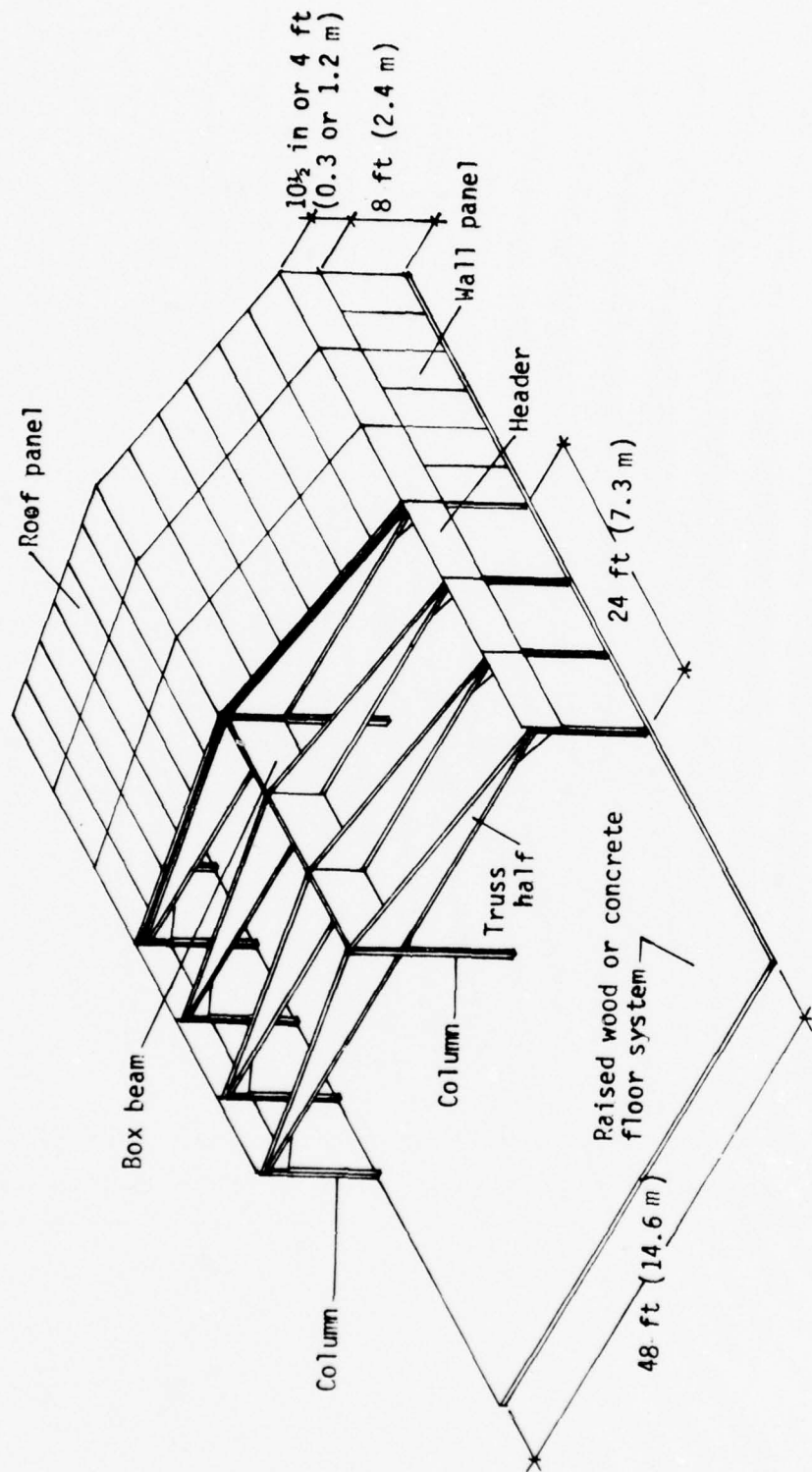

Figure 3. Building system for 48-ft (14.6-m) widths.

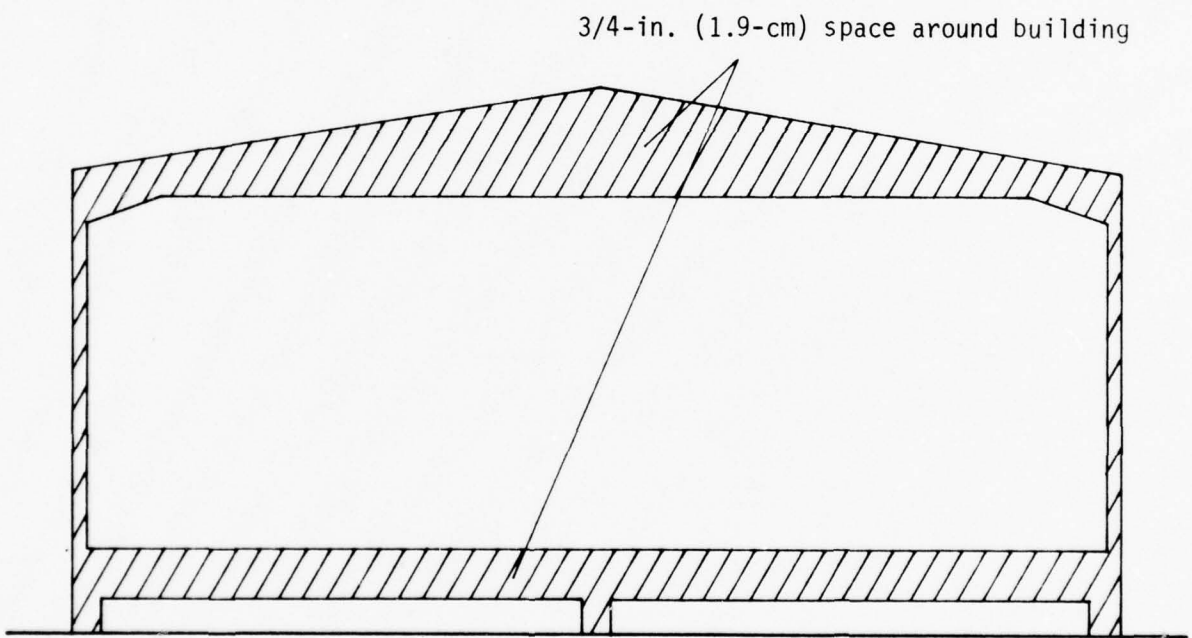

Figure 4. Cross-sectional for connections.

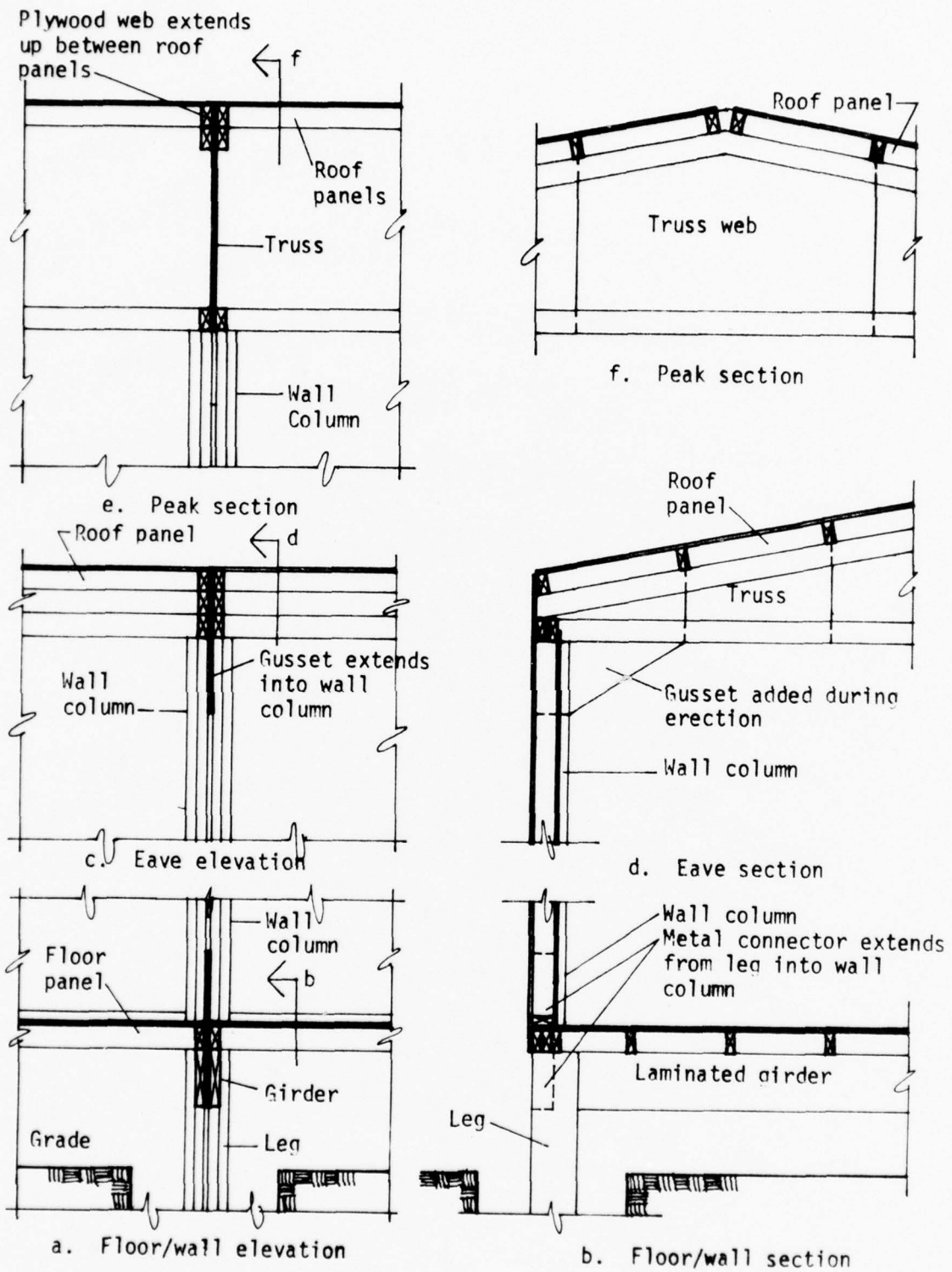

Figure 5. Method by which components interlock.

24- and 36-ft (7.3- and 10.9-m) Components      48-ft (14.6-m) Components

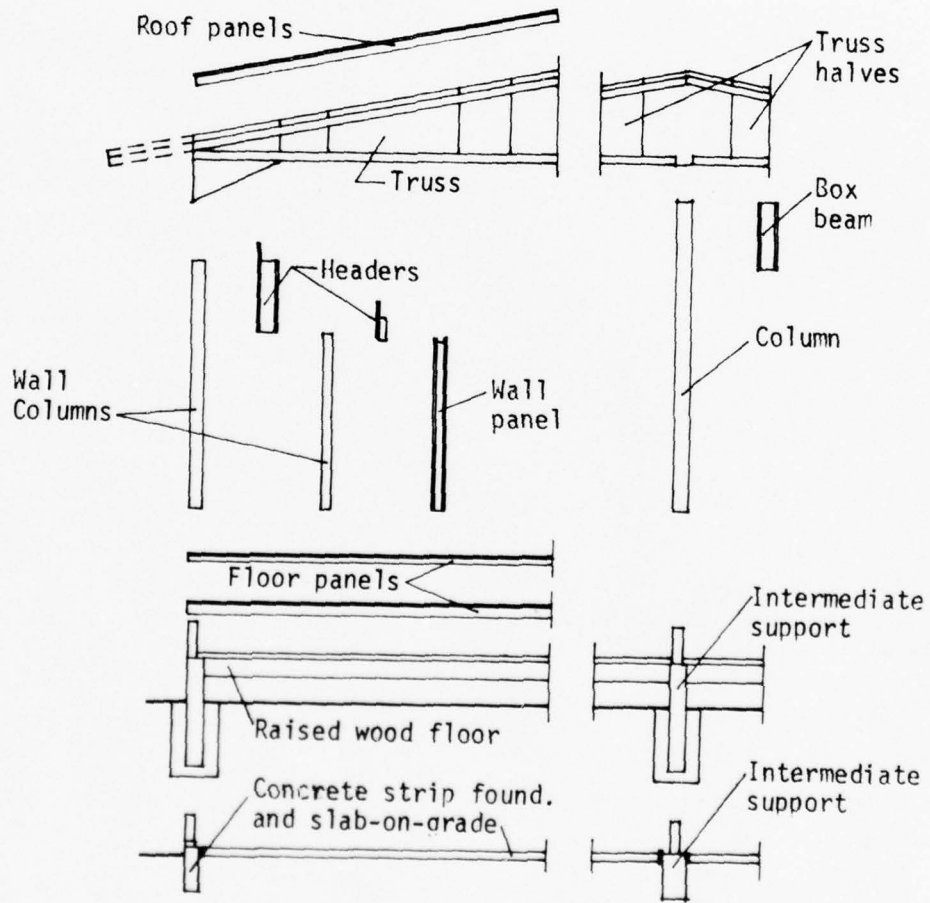
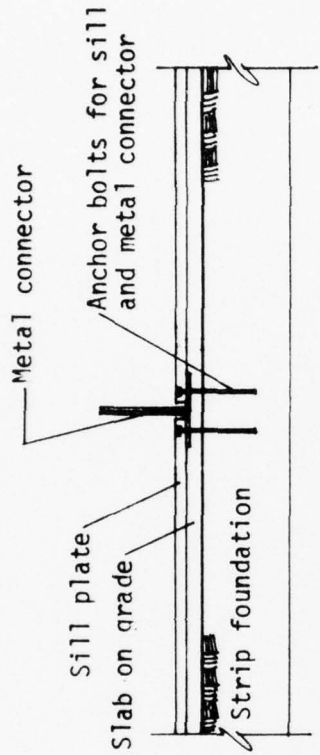

Figure 6. Building system components.



b. Elevation

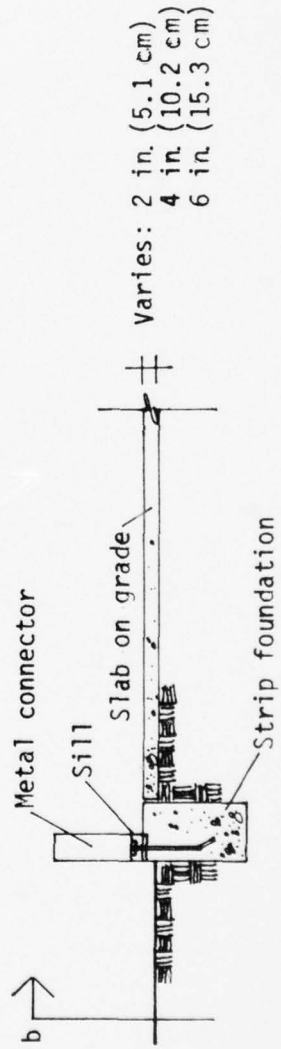

Figure 7. Concrete floor.

2. Posts for the raised wood floor (Figure 8) are built up from two 2-in. by 8-in. (5.1-cm by 20.3-cm) and 1-in. by 8-in. (2.5-cm by 20.3-cm) boards. The posts extend a minimum of 3 ft (0.9 m) below grade and are positioned on 12-ft (3.7-m) centers. The laminated girder is built up from two 2-in. by 10-in. (5.1-cm by 25.4-cm) boards and 3/4-in. (1.9-cm) plywood. The plywood extends above the girder to provide a connection for the floor panels. The girders are located on 8-ft (2.4-m) centers. A metal strap extends from the outside posts through the floor panels to tie the wall column to the post.

#### *Wall Columns*

Sidewall columns are built up from 2-in. (5.1-cm) lumber. The column size depends on the building width, as indicated in Figure 9. Edge members of the wall panels serve to complete each column. When the system is designed to be used for open storage, the column is built up from four pieces of 2-in. (5.1-cm) lumber. Endwall columns consist of double (nominal) 2-in. by 4-in. (5.1- by 10.2-cm) lumber. The end columns are intended for use in open storage buildings. When wall panels are installed, edge members of the end panels meet to form this column.

#### *Wall Panels*

The wall panels are fabricated from two sheets of 1/2-in. (1.3-cm) plywood and framed with nominal 2-in. by 4-in. (5.1- by 10.2-cm) lumber, as shown in Figure 10. These panels are single faced, the plywood lapping the floor panels, wall columns, and header above. Windows and doors may be prefabricated or installed at the site.

#### *Headers*

For an 8-ft (2.4-m) eave height, the small header (Figure 11) consists of a single ply of 1/2-in. (1.3-cm) plywood and a built-up section of nominal 2-in. by 4-in. (5.1-cm by 10.2-cm) lumber and 1/2-in. (1.3-cm) plywood. A box beam is constructed for the 12-ft (3.7-m) eave height from nominal 2-in. by 4-in. (5.1-cm by 10.2-cm) lumber and two 1/2-in. (1.3-cm) plywood faces. Each header spans 8 ft (2.4 m) between wall columns. The top of each header is nailed to the roof panels after the latter are installed.

#### *Trusses*

Trusses for the 24- and 36-ft (7.3-m and 10.9-m) buildings provide a clear span interior space (Figure 12). These trusses and the components for the 48-ft-wide (14.6-m-wide) building are sloped "I" beams built up as dimensioned lumber flanges and plywood webs. The 24-ft (7.3-m) truss has double 2-in. by 4-in. (5.1-cm by 10.2-cm) flanges and a single 3/4-in (1.9-cm) web. The 36-ft (10.9-m) truss has double 7-in.

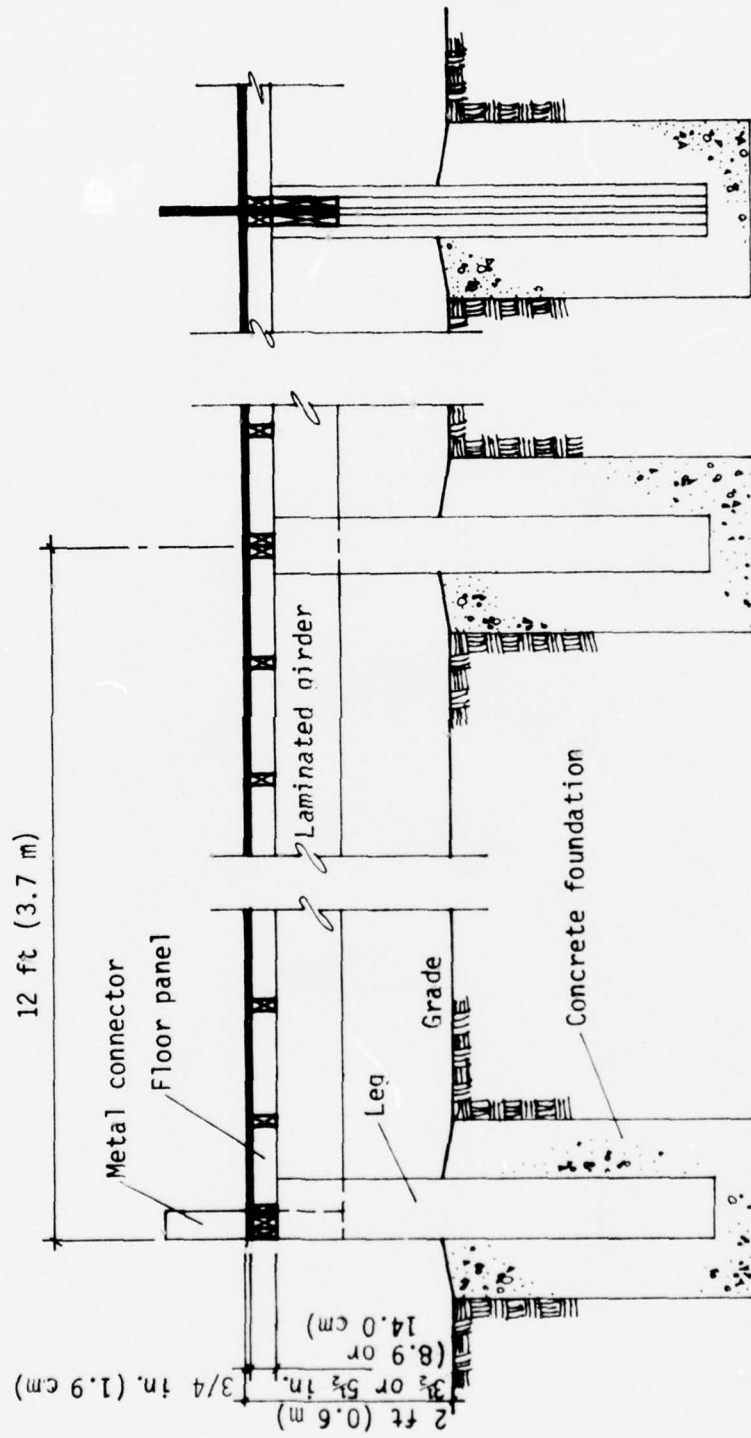



Figure 8. Raised wood floor.

Building  
Width

48-ft  
(14.6 M) 

Double nominal 2-in. by 4-in. and 2-in. by 8-in.  
(5.1- by 10.2-cm and 5.1- by 20.3-cm) lumber

36-ft  
(10.9 M) 

Double nominal 2-in. x 4-in. and 2-in. by 6-in.  
(5.1- by 10.2-cm and 5.1- by 15.3-cm) lumber

24-ft  
(7.3 M) 

Four nominal 2 in. by 4 in.  Two nominal 2-in. by 4-in.  
(5.1 by 10.2 cm) (5.1- by 10.2-cm) lumber

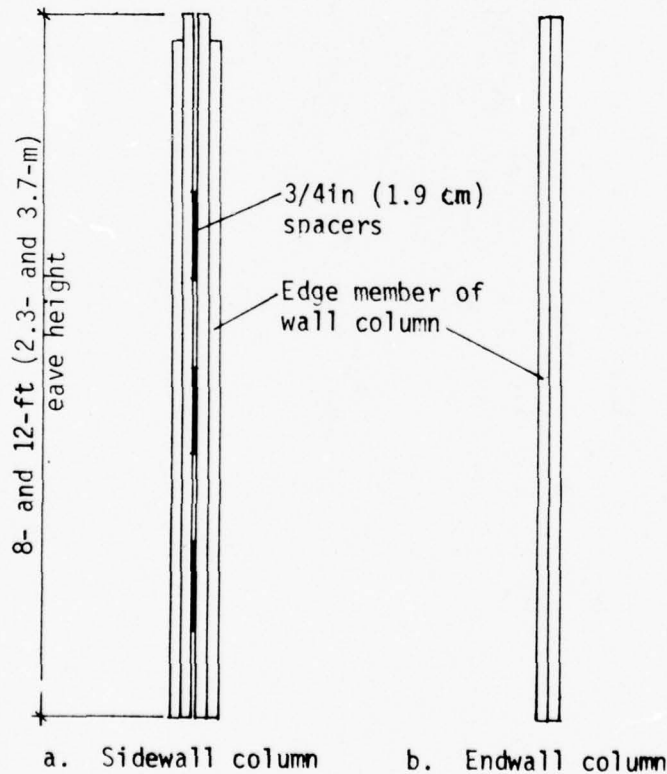
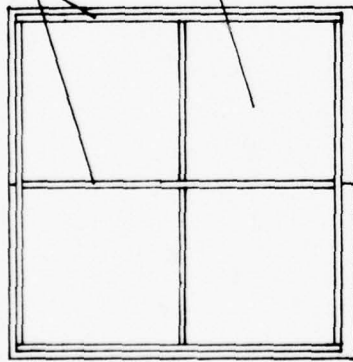

Figure 9. Wall columns.

Typical dimensions: 8 ft by 8 ft (2.4 by 2.4 m)



2x4 (5.1- by 10.2-cm) frame typical

Single plywood face typical

a. Blank panel

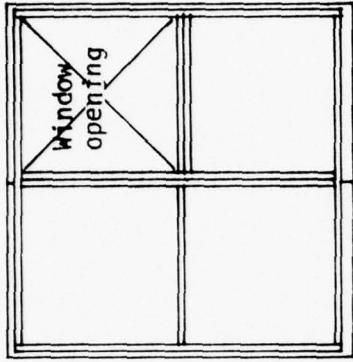

b. Window panel

Plywood lip around panels lap the floor panels, columns, and header above the wall panels

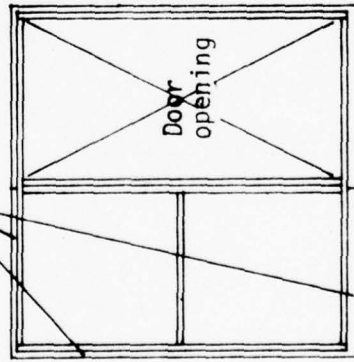

c. Door panel

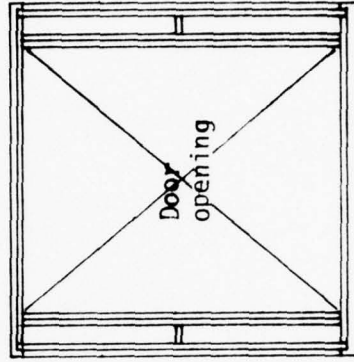

d. Double door panel

Figure 10. Wall panels.

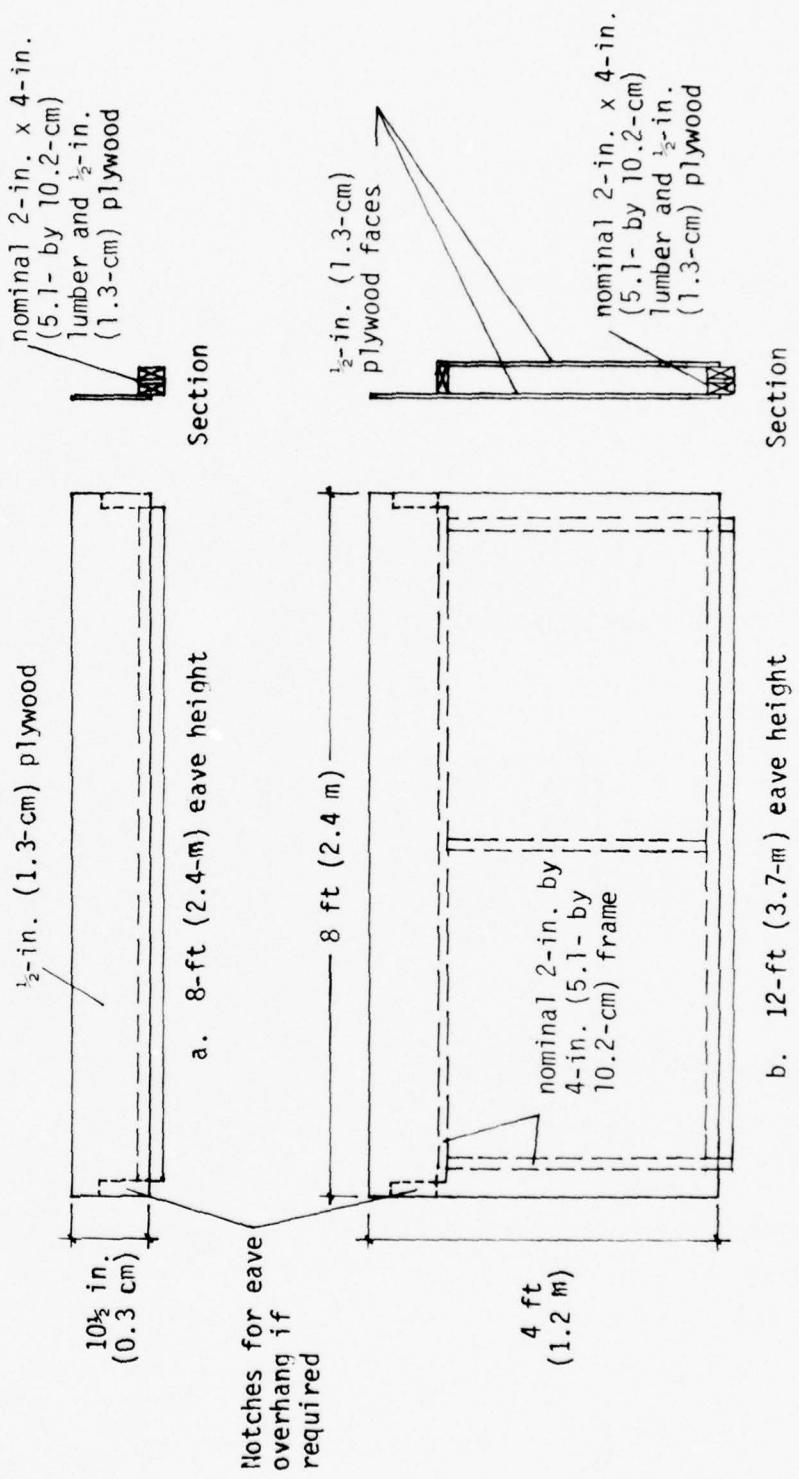

Figure 11. Wall headers.

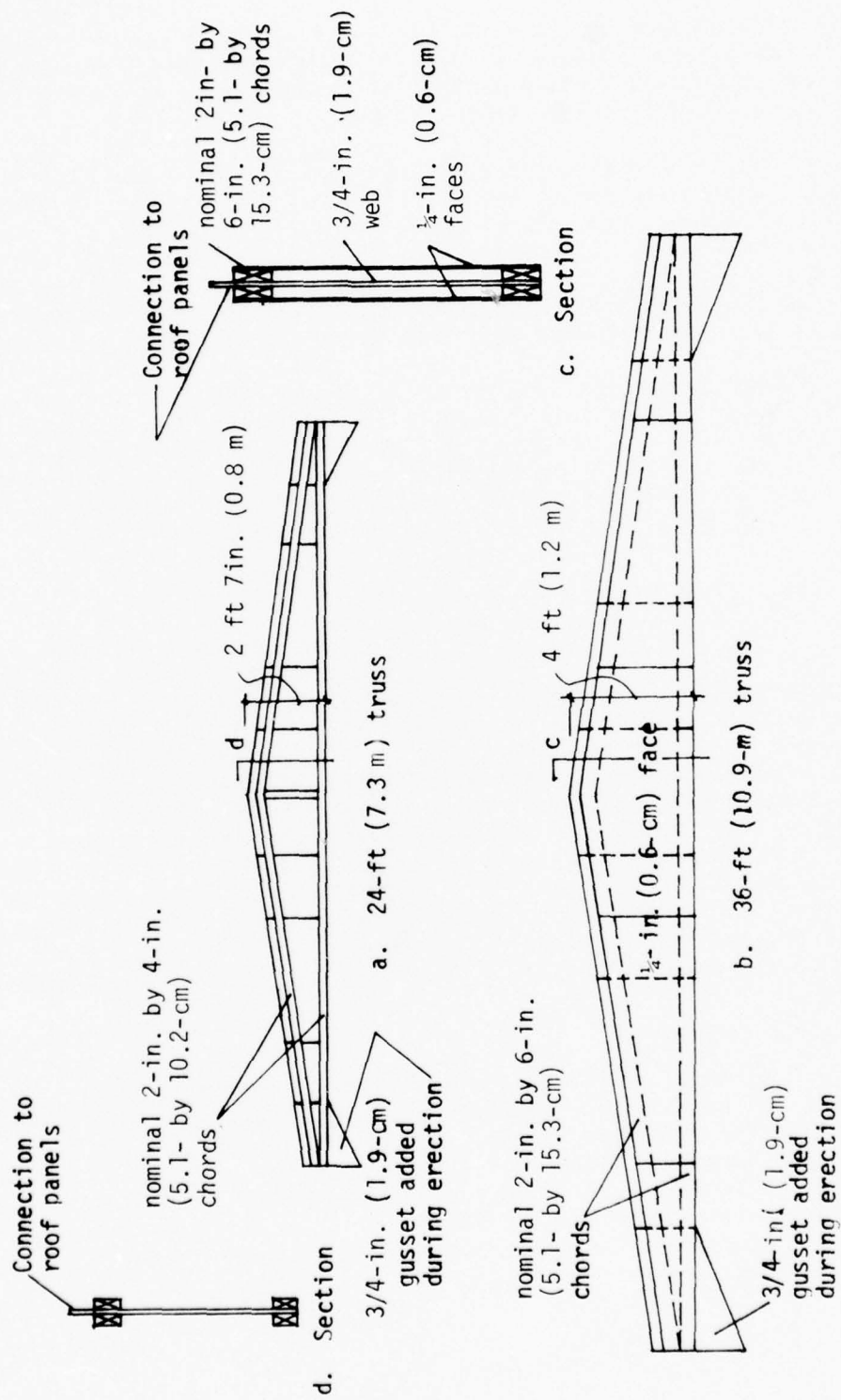

Figure 12. Trusses for 24- and 36-ft (7.3- and 10.9-m) buildings.

by 6-in. (5.1-cm by 15.3-cm) flanges, a 3/4-in. (1.9-cm) web, and outer plies of 1/4-in. (0.6-cm) plywood. In both trusses, a plywood gusset is added to the wall column so that it extends below the bottom chord to connect the wall column to the truss.

The structural support for the roof system of the 48-ft (14.6-m) building is composed of two 24-ft (7.3-m) truss halves, a 24-ft (7.3-m) ridge box beam, and columns on 24-foot (7.3-m) centers (Figure 13). The truss half is built up from 2-in. by 4-in. (5.1-cm by 10.2-cm) lumber and 3/4-in. (1.9-cm) plywood. The box beam is built up from 2-in. by 12-in. (5.1-cm by 30.5-cm) lumber, a 1/2-in. (1.3-cm) plywood center web, and two outer webs made from two plies of 3/4-in. (1.9-cm) plywood.

During erection, the truss halves are joined at the column by nailing flange members to a 3/4-in. (1.9-cm) plywood web at the column (Figure 14a). The box beam is then erected between these components. The truss halves are connected to the box beam by two 3/4-in. (1.9-cm) plywood pieces which pass through the box beam. Flange members are then nailed to the plywood to complete the splice (Figure 14b).

#### *Floor and Roof Panels*

Five floor panels and two roof panel types are required as shown in Figure 15. Floor panels may be fabricated for either a 40 or 100 psf (195.2 kg/m<sup>2</sup> or 488 kg/m<sup>2</sup>) live load using 2-in. by 4-in. (5.1-cm by 10.2-cm) or 2-in. by 6-in. (5.1-cm by 15.3-cm) joist material. Roof panels are fabricated from 2-in. by 4-in. (5.1-cm by 10.2-cm) material. Floor panels are fabricated with joists on 16-in. (40.6-cm) centers. Joists for the roof panels are on 24-in. (61.0-cm) centers. Bearing support for wall columns and wall panels is provided by multiple joists at the building perimeter. The number of these joists is dependent on the size of the wall column. The thickness of the plywood used for the floor and roof panels is 3/4-in. (1.9-cm) and 1/2-in. (1.3-cm), respectively. The plywood in both panel types laps the plywood in the truss or laminated girder. The panels are flush at the building ends.

#### *Endwall Components*

Figures 16 and 17 show elevations and framing sections for the truss and endwall panels. Figure 18 shows sections cut through the endwall for each eave height. The endwall panels are similar to the sidewall panels. A layer of 1/2-in. (1.3-cm) plywood covers the end truss. The wall panels lap the bottom chord in buildings with an 8-ft (2.4-m) eave height and the bottom of the header in those with a 12-ft (3.7-m) eave height. The endwall header for the 12-ft (3.7-m) eave height laps the bottom chord of the end truss.

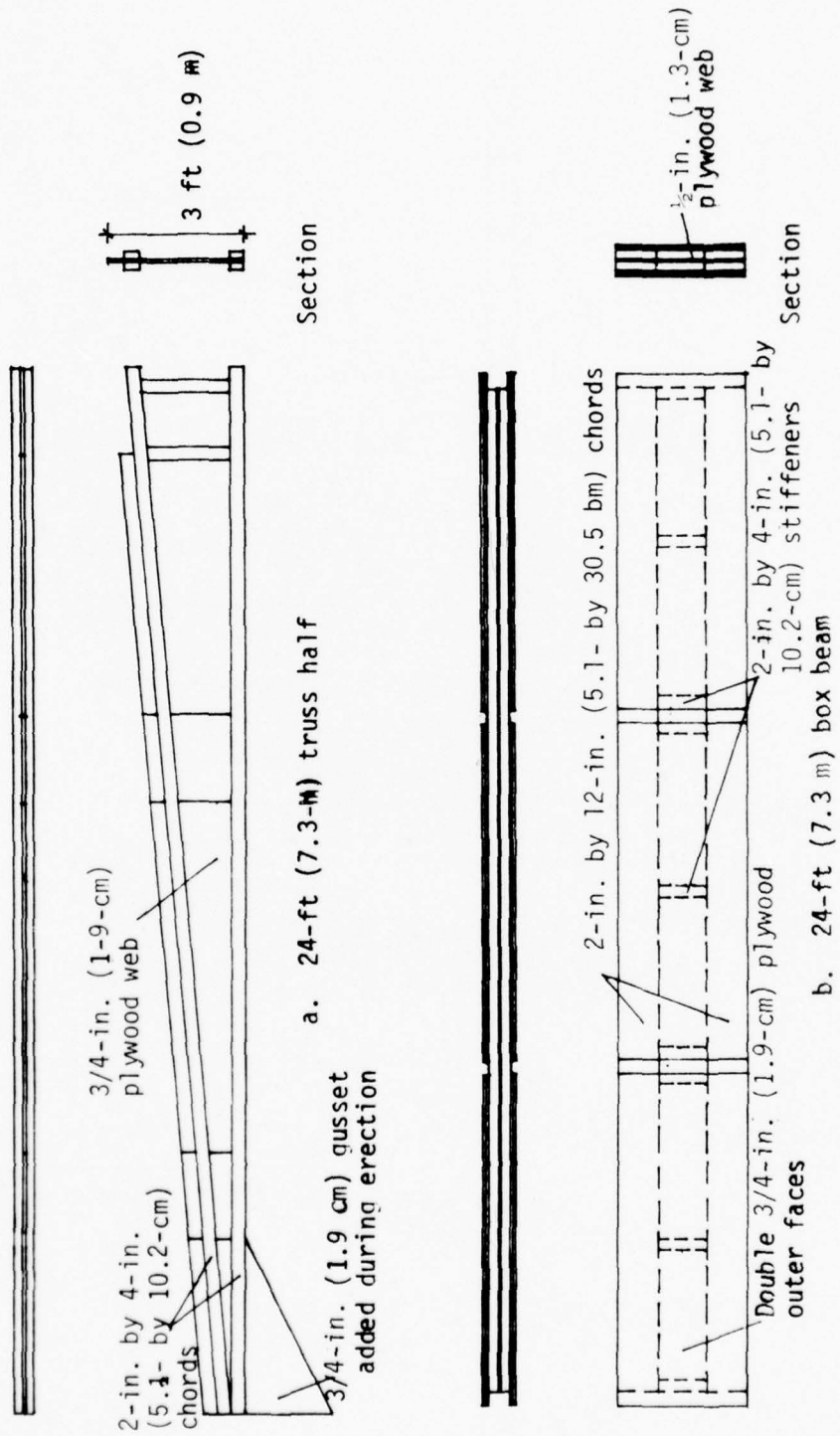
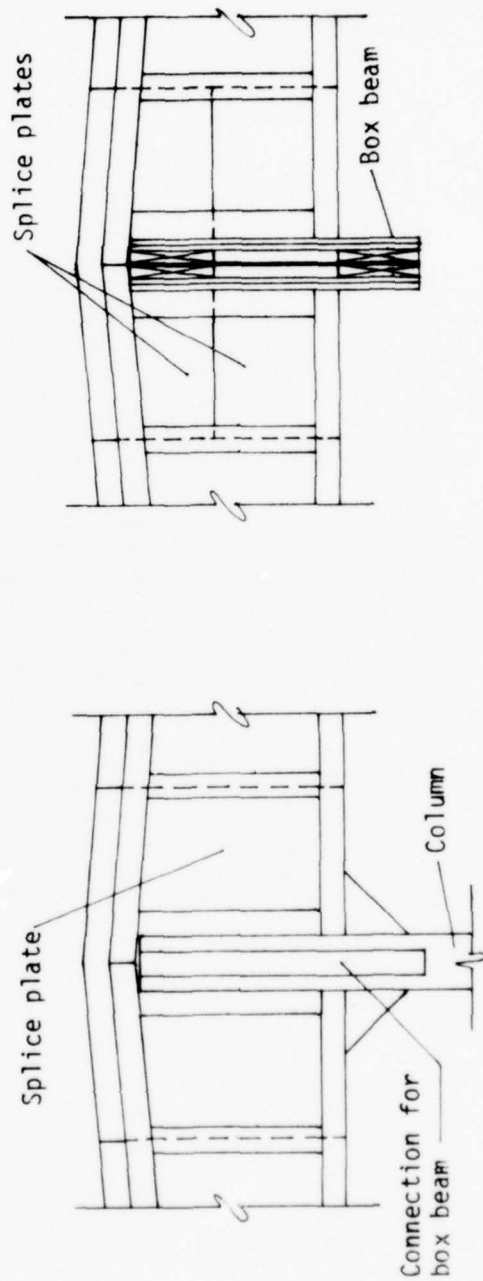
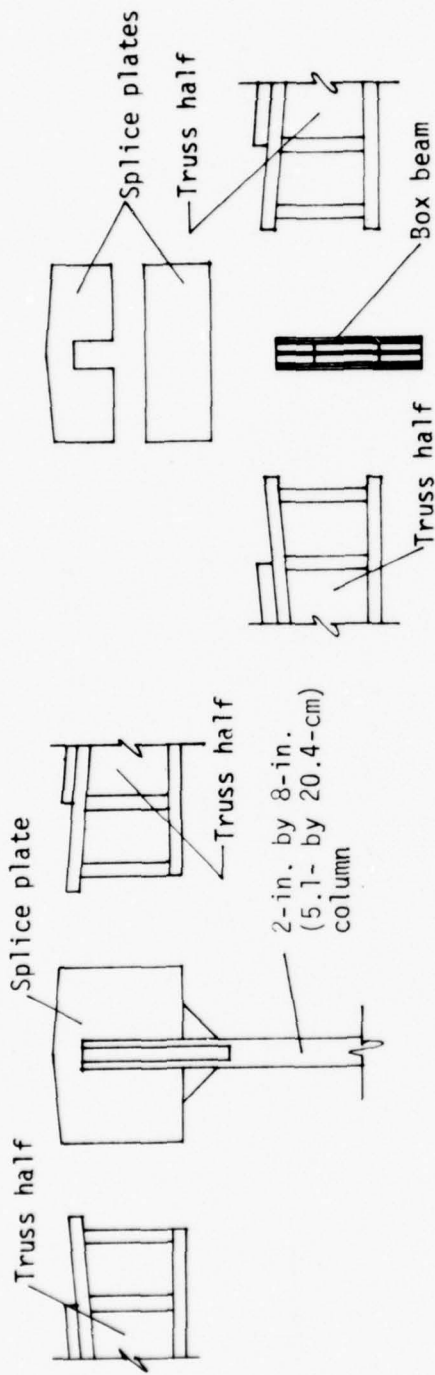

Figure 13. Trusses for 48-ft (14.6-m) building.



b. Connection to box beam

a. Connection to column

Figure 14. Truss connection methods for 48-ft (14.6-m) building.

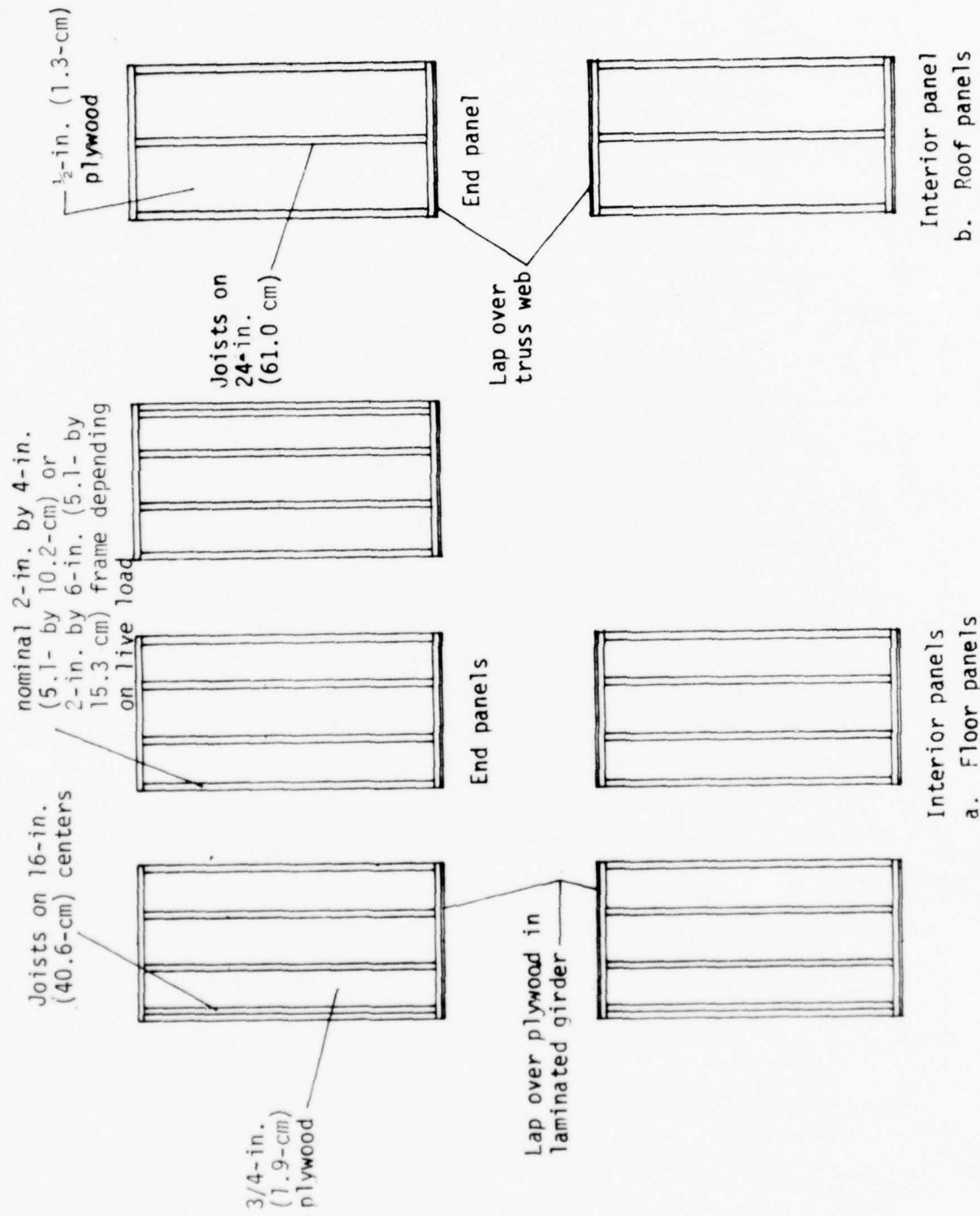

Figure 15. Floor and roof panels.

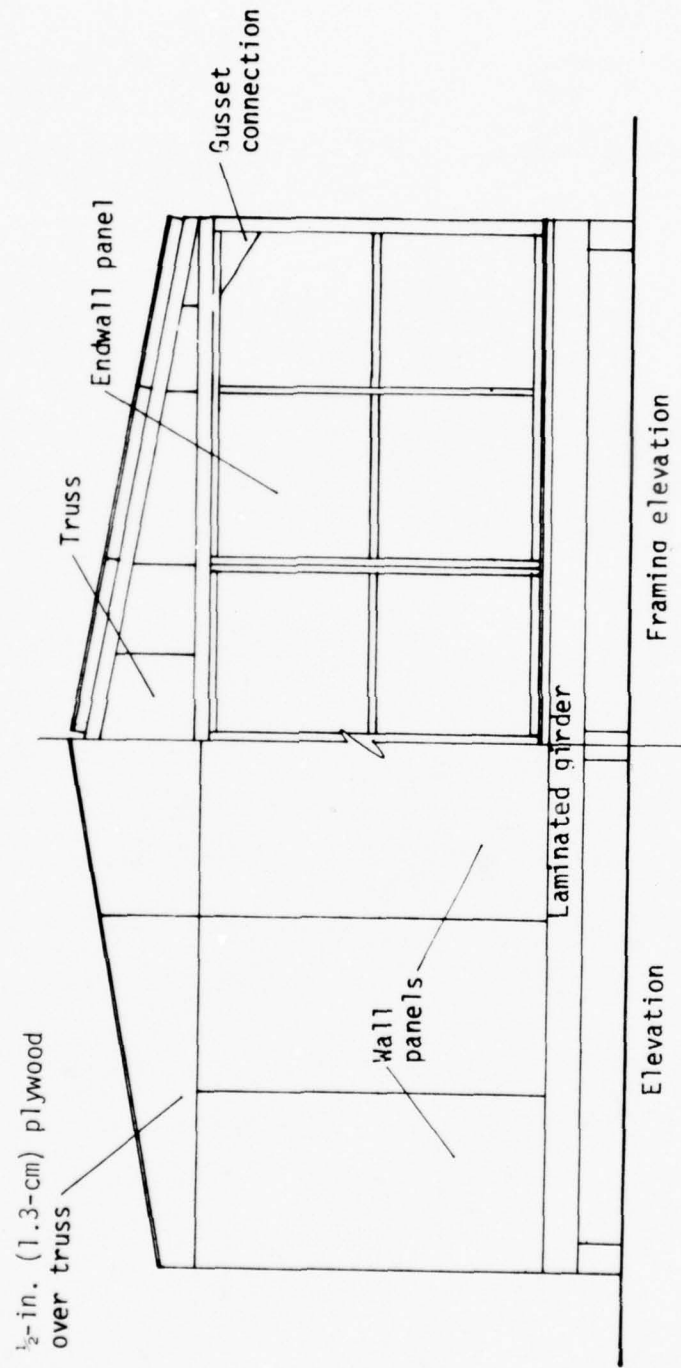

Figure 16. Building endwall for 8-ft (2.4-m) eave height.

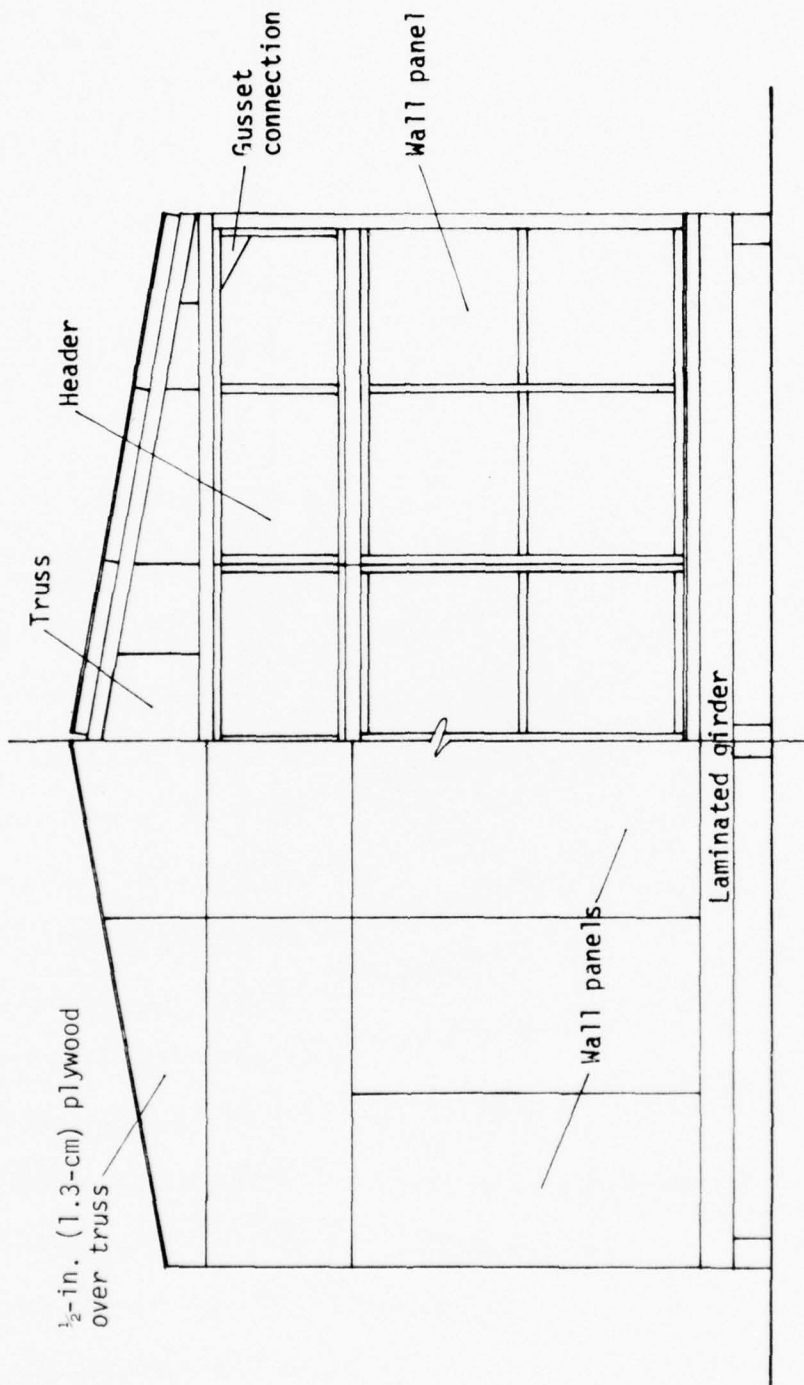
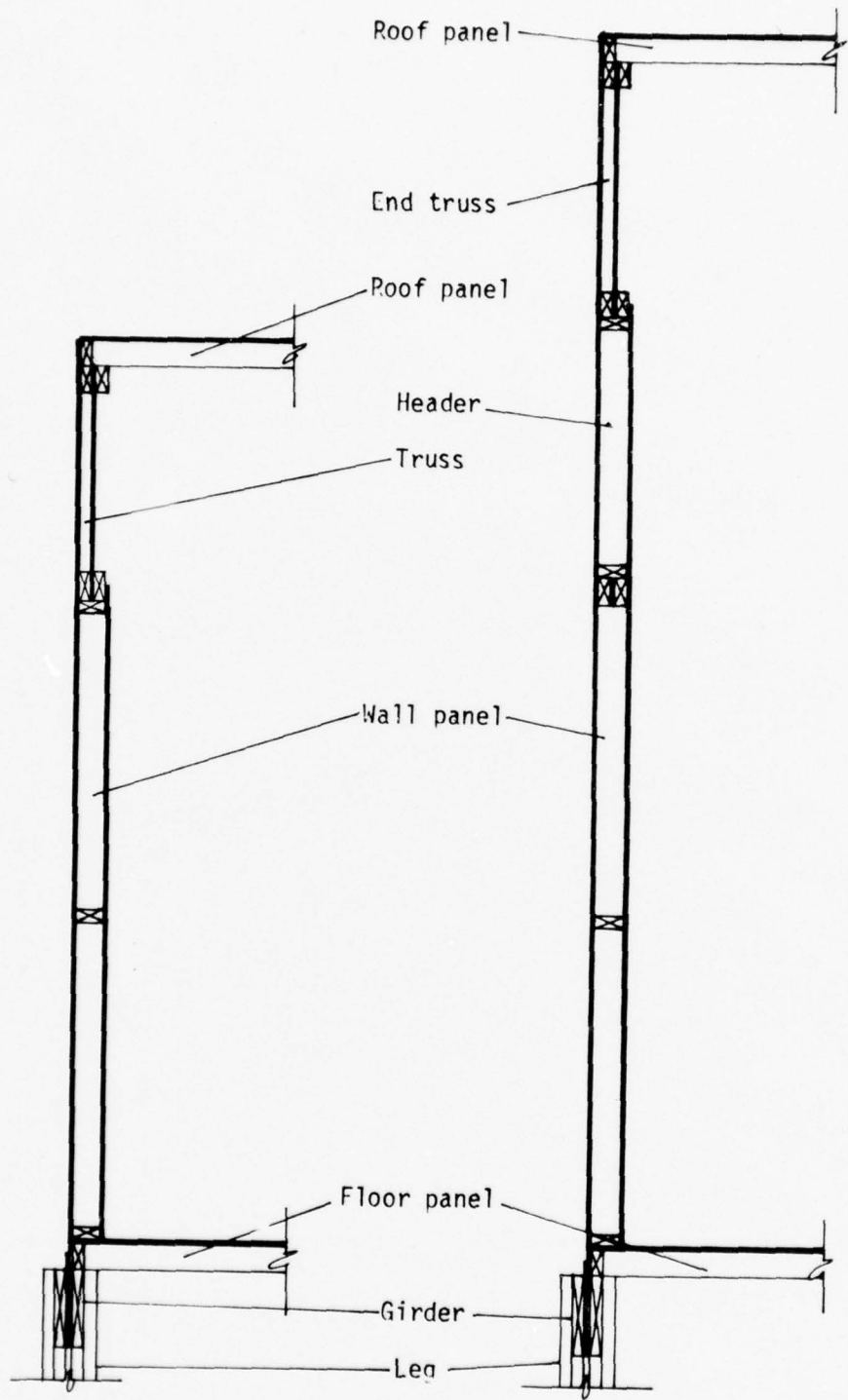

Figure 17. Building endwall for 12-ft (3.7-m) eave height.



a. 8-ft (2.4-m) eave height

b. 12-ft (3.7 m) eave height

Figure 18. Endwall sections.

## Climatic Options

In addition to providing for facilities of various sizes, this building system was also designed to accommodate alterations required for use in differing climates. Suggested material and component options for temperate, tropical, and desert climates are presented in Table 4. As mentioned previously, these options are based on the results of another research project in progress at CERL.<sup>10</sup> Typical configurations for the three climates are shown in Figure 19, which indicates the materials and components that should be added to each structural configuration for use in a particular climate.

For the temperate option, either wood or concrete floor systems are feasible. Common structural components can be installed without change. Insulation board should be installed on the interior face of wall and roof panels. Awning-type windows and screens should be fabricated and installed. Felt roofing nailed to the roof panels serves as the waterproofing membrane.

It is recommended that tropical buildings be erected on raised wood floor systems when loading conditions permit to provide maximum ventilation. Standard structural components are used, although the top truss chords should be extended 4 ft (1.2 m) as an eave to shade the building walls and protect them from rain. Sheets of corrugated metal should be added to the exterior surface of the roof panels for additional protection from rain and solar radiation. The metal should be whitewashed periodically to maximize reflectivity. A ceiling should be installed using insulation board. The presence of the ceiling provides an air space which is naturally ventilated at the roof peak and the eaves to reduce interior ceiling surface temperatures. In areas subject to high wind damage, a tie-down kit (cyclone bolt) should be provided to anchor the roof, wall, and floor components. Window openings should be screened and equipped with an awning-type plywood protective cover. A hooded vent at the floor level should be provided for ventilation.

Buildings in desert climates should be erected on concrete slabs on grade to take advantage of the relatively cooler ground. Asbestos-cement sheets should be added to the wall panel exterior surfaces to protect them from dust and wind. Batt insulation should be installed in the wall panels to resist heat penetration. A 4-ft (1.2-m) eave should be provided to protect the walls from solar radiation. Window coverings should be hinged so that they can be opened during evening hours for ventilation, and they should be filled with batt insulation. The ceil-

---

<sup>10</sup> A. Kao and J. Cook, Preliminary Design and Construction Guidelines for Vertical Construction in Desert and Tropical Theaters of Operation, Interim Report C-74/ADA032124 (CERL, October 1976).

Table 4  
Climatic Options

Component	Climate	
	Temperate	Desert
Floor Systems	Raised wood; slab on grade	Raised wood; slab on grade
Wall Columns	Yes	Yes
Header	Yes	Yes
Truss	Yes, with or without eave	Yes, with eave
Roof Panel	Exterior: plywood Interior: insulation board	Exterior; 1/2-in. (1.3 cm) plywood
Ceiling	Optional	Batt insulation
Ventilated Attic Space	Optional	Yes
Wall Panel	Ext.: 1/2-in. (1.3 cm) plywood Int.: insulation board and fiberboard	Ext.: 1/4-in. (0.6 cm) asbestos & 1/2-in. (1.3 cm) plywood Int.: batt insulation and fiberboard
Roof Membrane	Felt, nailed	Felt, nailed and whitewashed
Tie-down straps	No	No

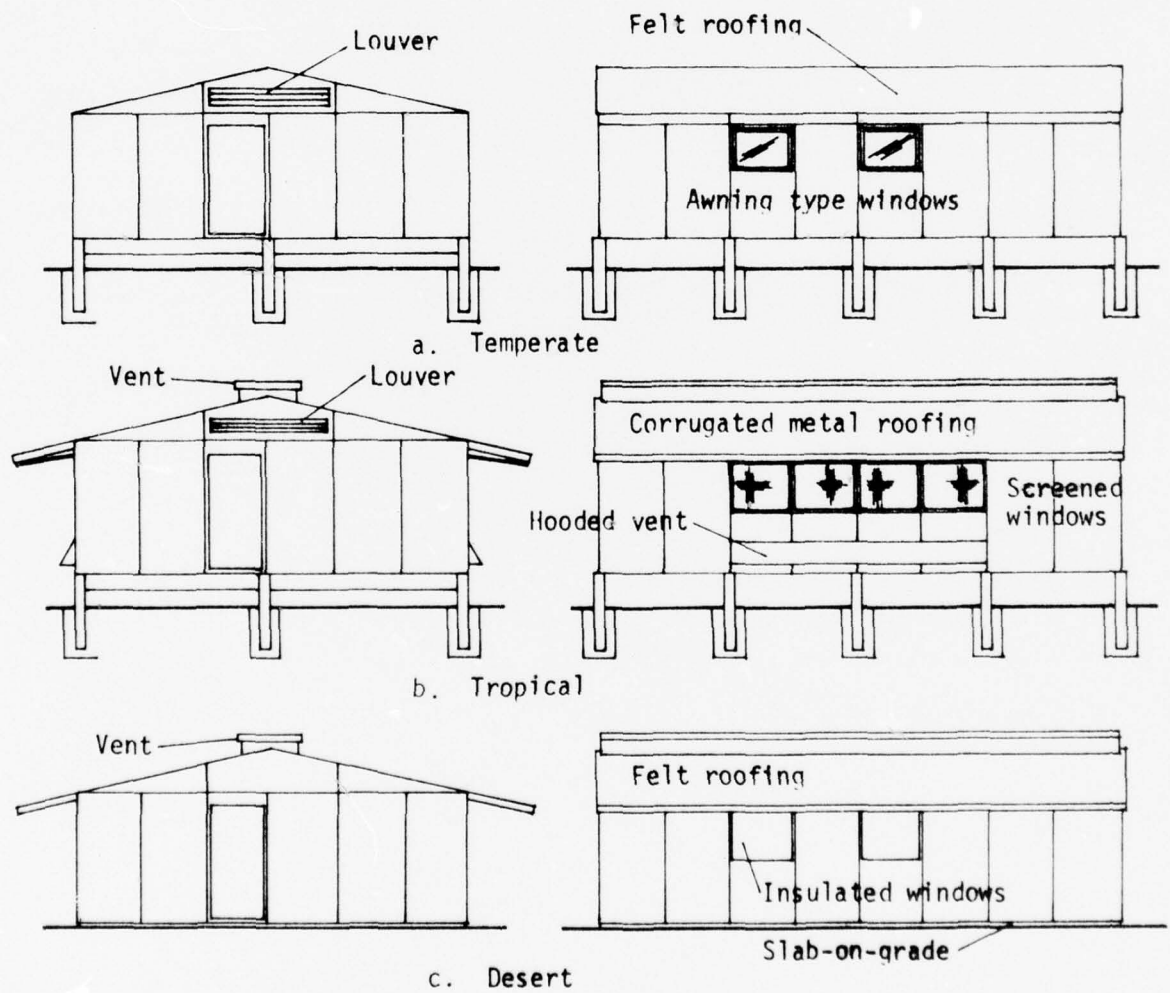

Figure 19. Climatic options.

ing should also be equipped with batt insulation. A whitewashed felt roof should be used to reflect solar radiation. The presence of a ventilated air space between the ceiling and the roof reduces heat buildup, and the ceiling insulation stores remaining heat. Figures 20 through 22 show wall sections for the three climatic options.

#### System Function

Through the use of expansion modules (see Figure 23), this building system is designed to maintain a high degree of flexibility for the commander, military planner, and construction supervisor. The basic recommended logistical data base for this system would contain a catalog of Bills of Material (BOMs) listing individual components grouped according to expansion modules. The BOMs for each module would include both structural components and panels. The catalog would also include BOMs for the different floor systems and climatic options.

The user of this building system would establish requirements for a facility or installation according to TO conditions and functional requirements. The overall dimensions for each facility would be determined by selecting one of the two available eave heights and the desired number of expansion modules. First, the end bays, endwalls, and intermediate bays would be selected. One of the alternative floor systems would then be chosen. Finally, climatic options would be added. The final BOM for a facility or installation would consist of a list of all options, endwalls, and bays desired.

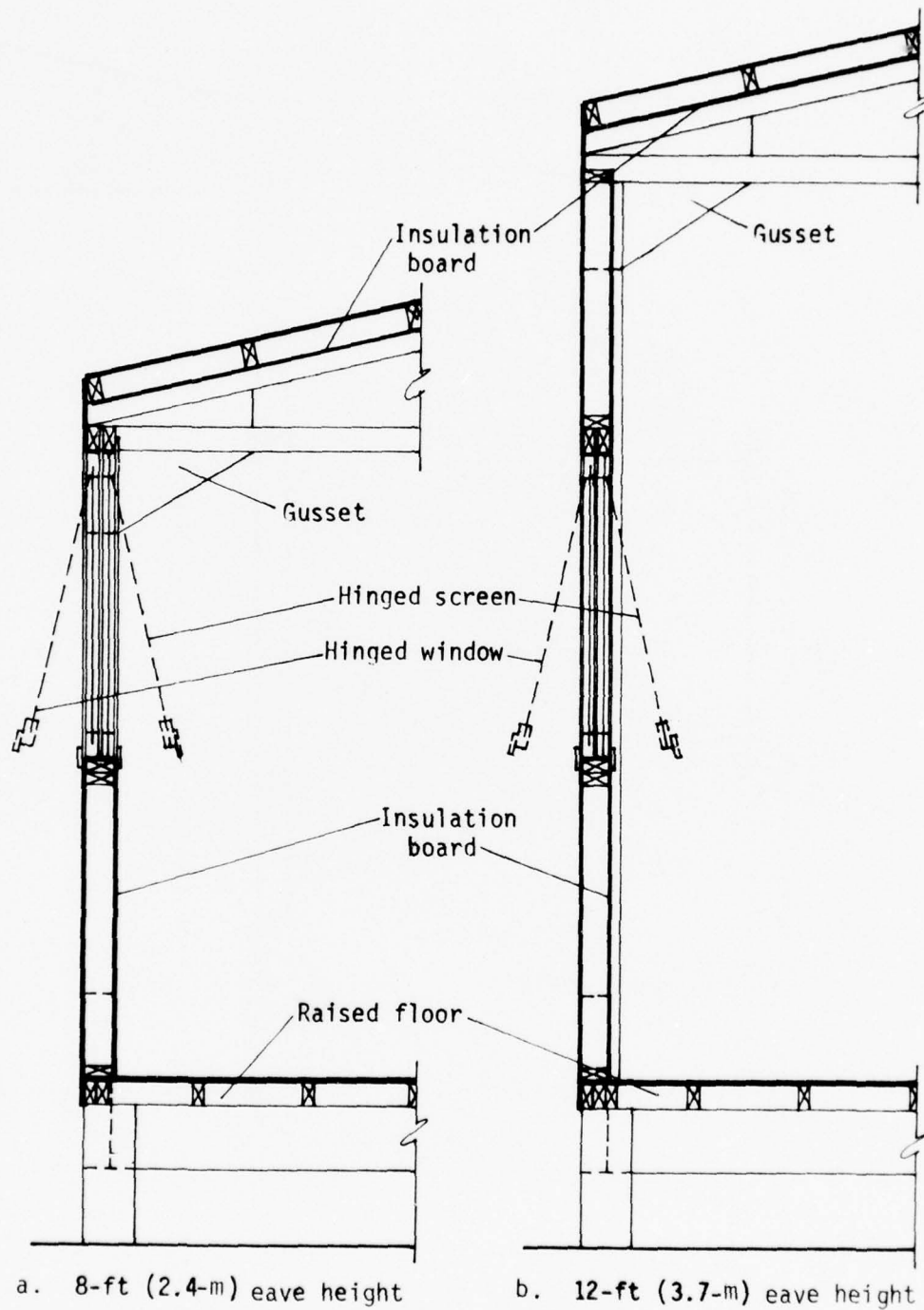

Figure 20. Wall section for buildings in temperate climates.

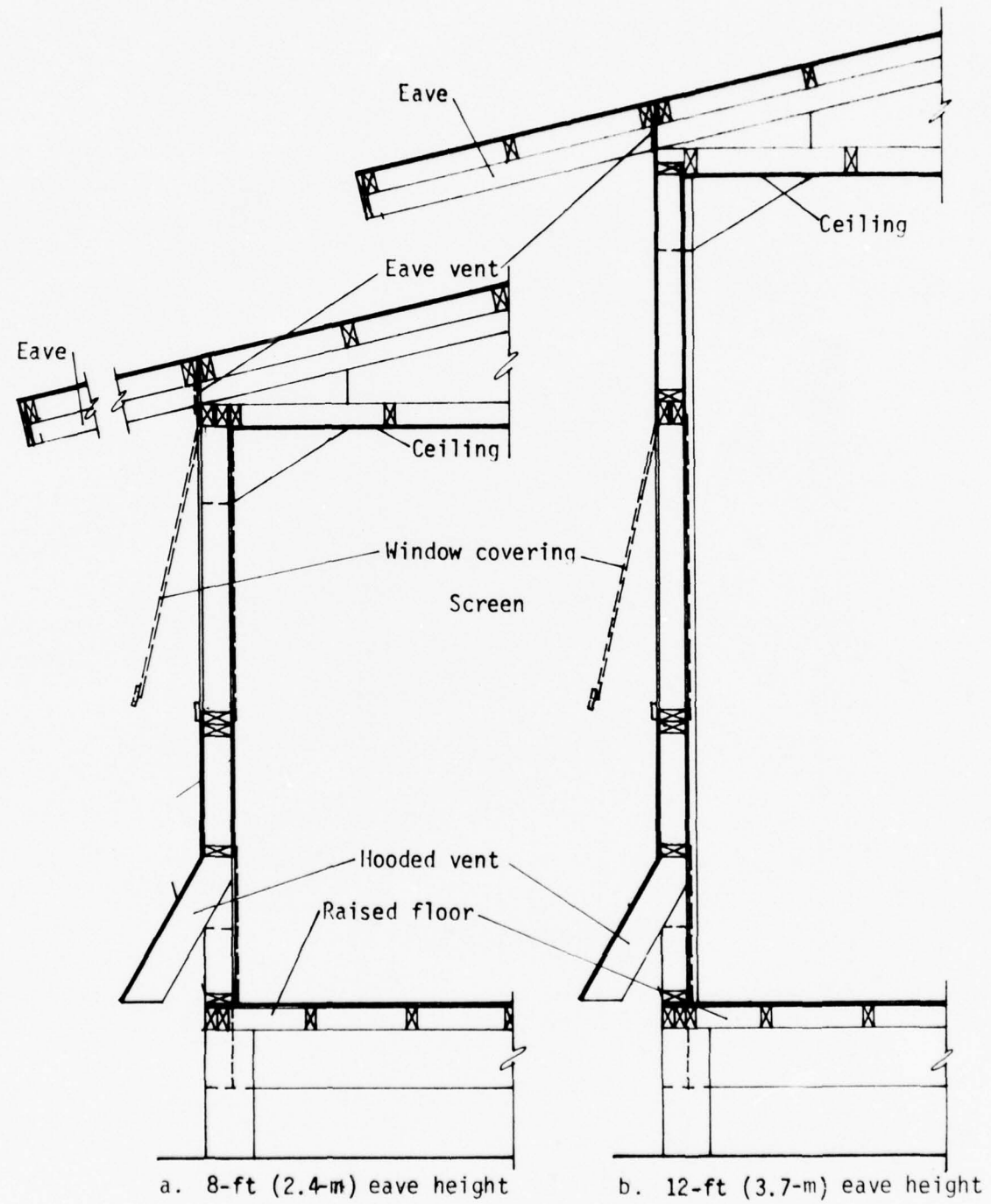

Figure 21. Wall sections for tropical buildings.

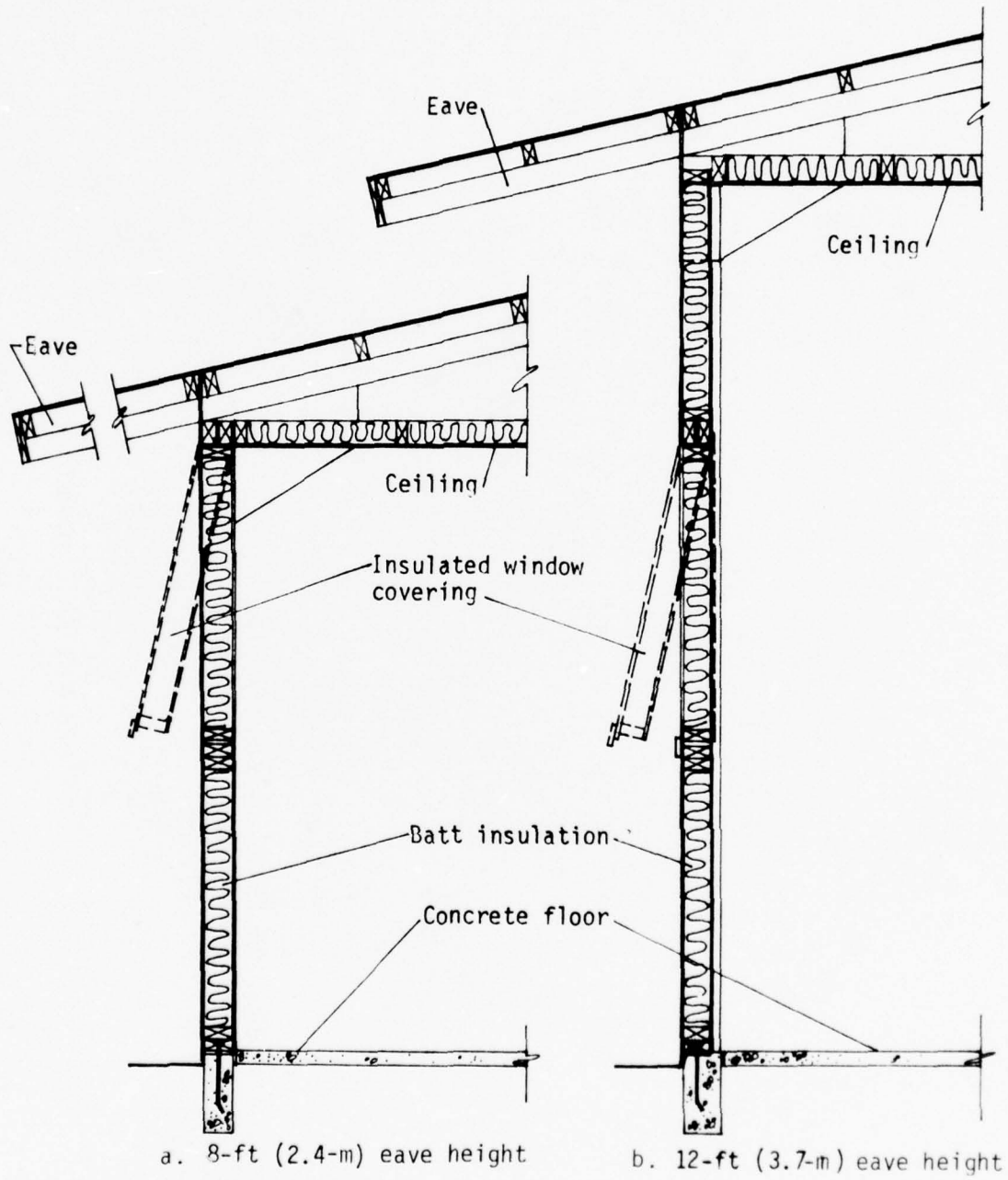

Figure 22. Wall sections for desert buildings.

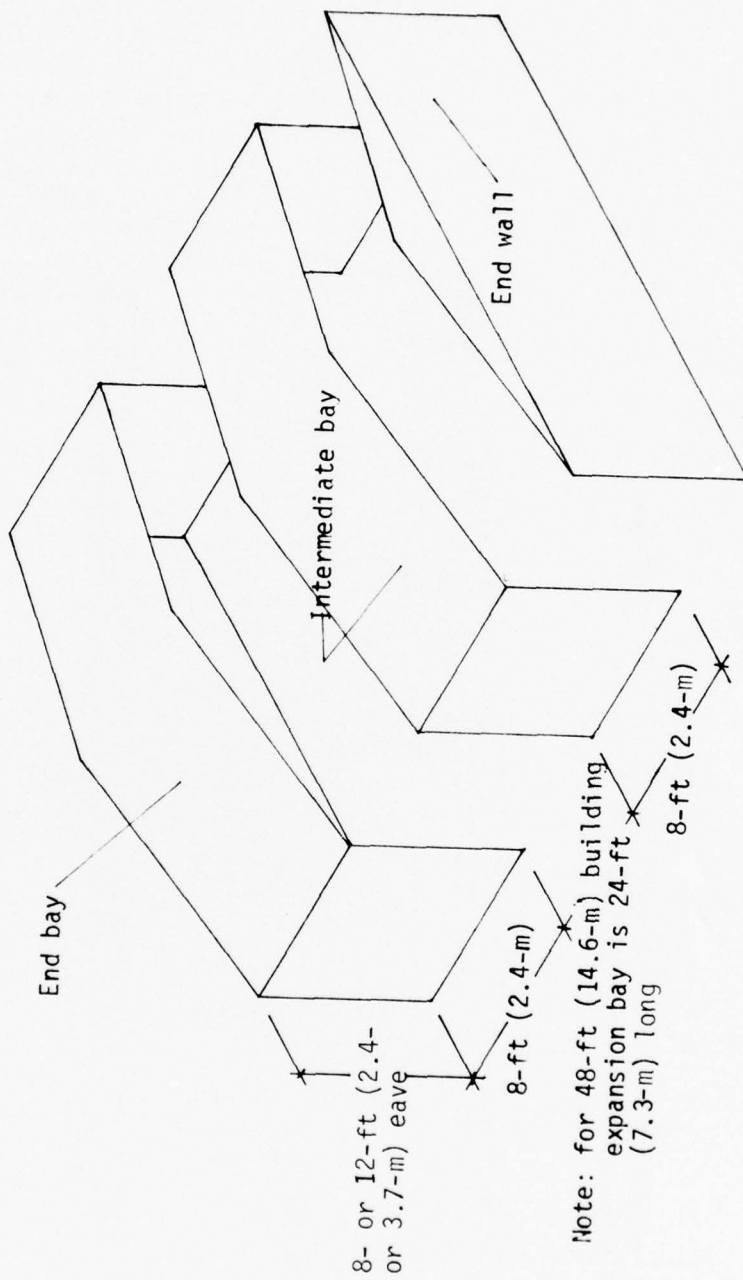

Figure 23. Expansion modules.

## 4 CONCLUSIONS AND RECOMMENDATIONS

### Conclusions

The results of this project indicate that it is feasible to construct panelized plywood buildings up to 48 feet (14.6 m) wide without the use of special equipment. Panels can be fabricated with a minimum of components. The building system designed allows for phased construction and provides the user a high degree of flexibility to meet various operational conditions. The system provides for three climatic options (temperate, tropic, and desert) and can be used to house administrative, supply, barracks, mess, hospital, and certain maintenance functions. This system will satisfy at least 95 percent of the total TO building requirements.

### Recommendations

Because of the rather unconventional detailing of the building system's main structural components, it is recommended that they be subjected to load tests to determine their adequacy. It is also recommended that the building design be field tested to insure that the design is satisfactory in terms of workable detailing, cost, labor factors, and performance.

## APPENDIX:

### FIELD EXPERIMENT ON A PREFABRICATED PANELIZED FOAM/WOOD STRUCTURE AT FORT RUCKER, AL

#### 1 INTRODUCTION

This appendix documents the August 1976 field test of the prefabricated panelized foam/wood structure at Fort Rucker, AL, compares the results with those of the Fort Belvoir field test, and evaluates the field test results in comparison to an AFCS Facility 3403 in terms of labor and cost.

#### 2 DESCRIPTION OF FIELD TESTS

The Fort Belvoir building was erected in September 1975 by troops assigned to the U.S. Army Engineer School (USAES), Department of Engineering Sciences (D-E/S). The building size is 24 by 40 ft (7.32 m by 12.12 m). Floor, wall, and roof panel components were prefabricated at CERL and shipped to Fort Belvoir. Structural components--the foundation bents and trusses--were fabricated by school personnel. Figure A1 is a photograph of the completed building.

Member of the 46th Engineer Combat Battalion (Heavy) erected the Fort Rucker building between May and August 1976. The building size was expanded to 24 by 80 ft (7.32 m by 24.24 m). This building is similar to the Belvoir building except for the addition of amenities such as windows, double doors, an eave, finish flooring, and interior partitions. Another difference between the two buildings was caused by the terrain at Fort Rucker; there is an approximate 4 ft (1.21 m) slope over the length of the building. Panel and structural component fabrication were handled in the same fashion as at Fort Belvoir. The Fort Rucker building is used as a classroom for the Survival, Escape, Resistance, and Evasion Course. Figure A2 shows the building exterior and Figure A3 is an isometric drawing (eave not shown) of the building system.

Both field test buildings were completed with spray-applied polyurethane foam insulation in the floor, wall, and roof panels. Since both buildings were to be used as classrooms -- and to meet the fire codes in the CONUS -- gypsum wallboard was added to the wall and roof panels to serve as a fire-retardant barrier. The wallboard was 3/8-in. (0.95-cm) and 5/8-in. (1.59-cm) thick at Forts Belvoir and Rucker, respectively. It should be noted that the polyurethane foam is not required in the TO.

### 3 CONSTRUCTION COST AND LABOR DATA

Both buildings were fabricated and erected similarly; i.e., holes augered; bents and floor panels installed; concrete footing poured; wall panels, trusses, and roof panels installed; and finishing operations completed. Figures A4 through A11, photographs taken at Fort Rucker, illustrate the general nature of the building system and the operations which occurred during erection.

Since this building system is expected to have some impact on the AFCS, AFCS Facility 3403, which is similar to the Fort Belvoir building, was chosen for comparison. Table A1 summarizes material cost, labor, and logistic requirements for the AFCS and Fort Belvoir buildings. The results of the comparison indicated that although there was no significant reduction in material, there was significant reduction (48 percent) in labor requirements for fabricating and erecting the building. The detail of the comparison between the Fort Belvoir Building and AFCS Facility 3403 is documented in a previous report.<sup>11</sup>

The total material cost for the Fort Belvoir building was \$4,695. Prefabrication of the floor, wall, and roof panels was accomplished at CERL in 141 manhours (MH). Fabrication of bents and trusses at Fort Belvoir required an additional 27 MH. The building was then erected in 122 MH, bringing the total prefabrication and erection labor time to 290 MH.

The total material cost of the Fort Rucker field test was \$11,349. Floor, wall, and roof panels were fabricated at CERL in 247 MH with prefabrication of bents and trusses at Fort Rucker requiring an additional 96 MH. The building was then erected in 584 MH, bringing the total labor time to 927 MH. The material cost and labor required for this building are considerably higher than those for the 24 by 40 ft (7.2 x 12.0 m) building at Fort Belvoir primarily because they include additional material and labor required for installing commercial windows and doors, interior partitions, eaves, and a more elaborate staircase. In addition, some of the walls were erected at night and less skilled personnel were used.

Table A2 summarizes construction cost and labor data for the two buildings.

---

<sup>11</sup> R. L. Trent, T. Whiteside, J. Robertus, Field Experiment on a Prefabricated Expandable Foam/Wood Structure, Interim Report C-50/ADA032726 (CERL, October 1976).

Based on comments from the project officer at Fort Rucker (see Annex), it appears that the basic building components shell was completed without excessive difficulty except for the foundation bents. Provision of a numbered sawing template would eliminate the difficulty in bent construction. Several minor problems were encountered during the finishing operations such as installing commercial doors and windows because of improper openings provided.

From this perspective, it is anticipated that labor required for the CERL building will fall somewhere between the results of these two field tests. It is expected that labor requirements will be reduced approximately 40 percent as compared to the AFCS building, since the Fort Rucker building required approximately 25 percent less labor to fabricate and erect. The material cost of the Fort Rucker building should be the same as that of the Fort Belvoir building if commercial windows and doors, interior partitions, and other amenities are excluded from the Fort Rucker building. Therefore, the material cost of the basic Fort Rucker building without polyurethane foam would be about the same as the AFCS building.

The results of the Fort Rucker field test have also substantiated the results of the Fort Belvoir field tests. The two tests have demonstrated the competitiveness of the CERL system in comparison with a comparable AFCS Facility 3403.

#### 4 RESULTS OF ANNUAL INSPECTION

The annual inspection of the Fort Rucker building was conducted on 8 December 1977. All parts of the building, including foundation bents, floor panels, wall panels, roof panels, were closely inspected and found to be structurally sound and in excellent condition. Unlike the Fort Belvoir building,<sup>12</sup> no rainwater seepage was observed, possibly because the joints between the wall and the floor panels were caulked and eaves are provided in the building.

Neither the interior nor exterior of the building exhibited any deterioration, primarily because the building has not been used as a classroom as originally planned; it has been used during the past year primarily as a storage facility.

---

<sup>12</sup> A. M. Kao, J. Cook, Alternative TO Building Systems: Progress Report, Special Report C-80/ADA042312 (CERL, 1977).

## 5 CONCLUSIONS

The two field tests of the CERL panelized building system have provided data which indicate the competitiveness of the system in comparison with AFCS Facility 3403. The primary benefit is to be found in labor savings. It has been found that up to 40 percent reduction in labor requirements can be achieved. If polyurethane is not used for insulation, the material costs of the two systems are comparable. Results of the annual inspection indicate that the building system should reach the expected 5-year design life without problem.



Figure A1. Completed Fort Belvoir building.



Figure A2. Completed Fort Rucker building.

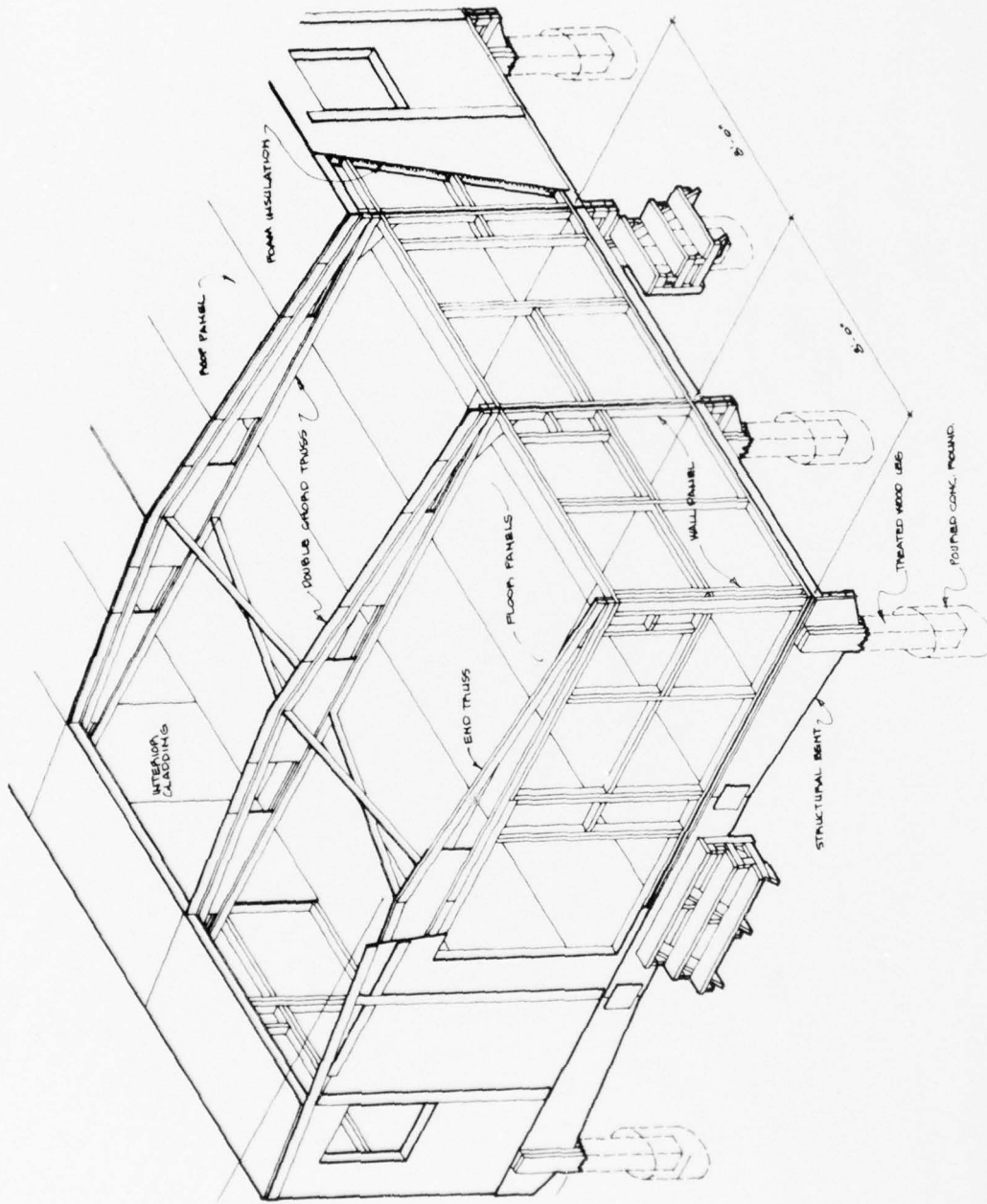

Figure A3. Isometric drawing of the paneled building system.

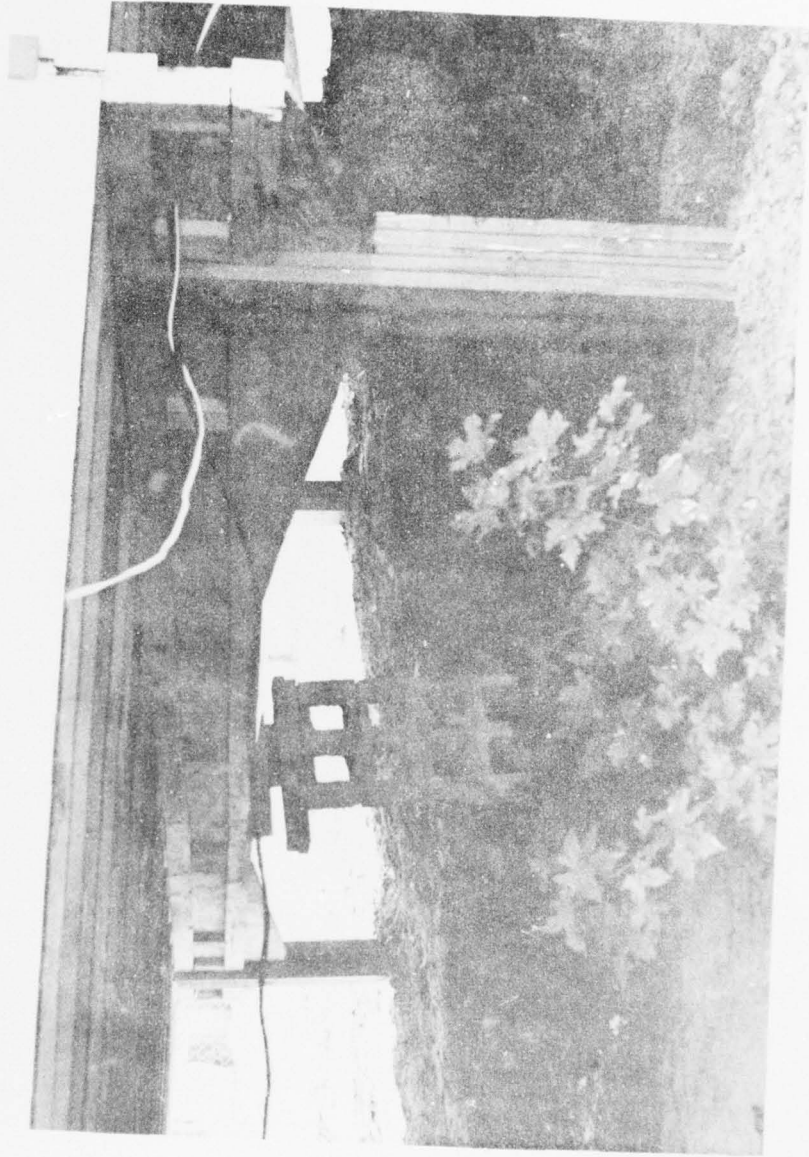

Figure A4. Foundation bent.

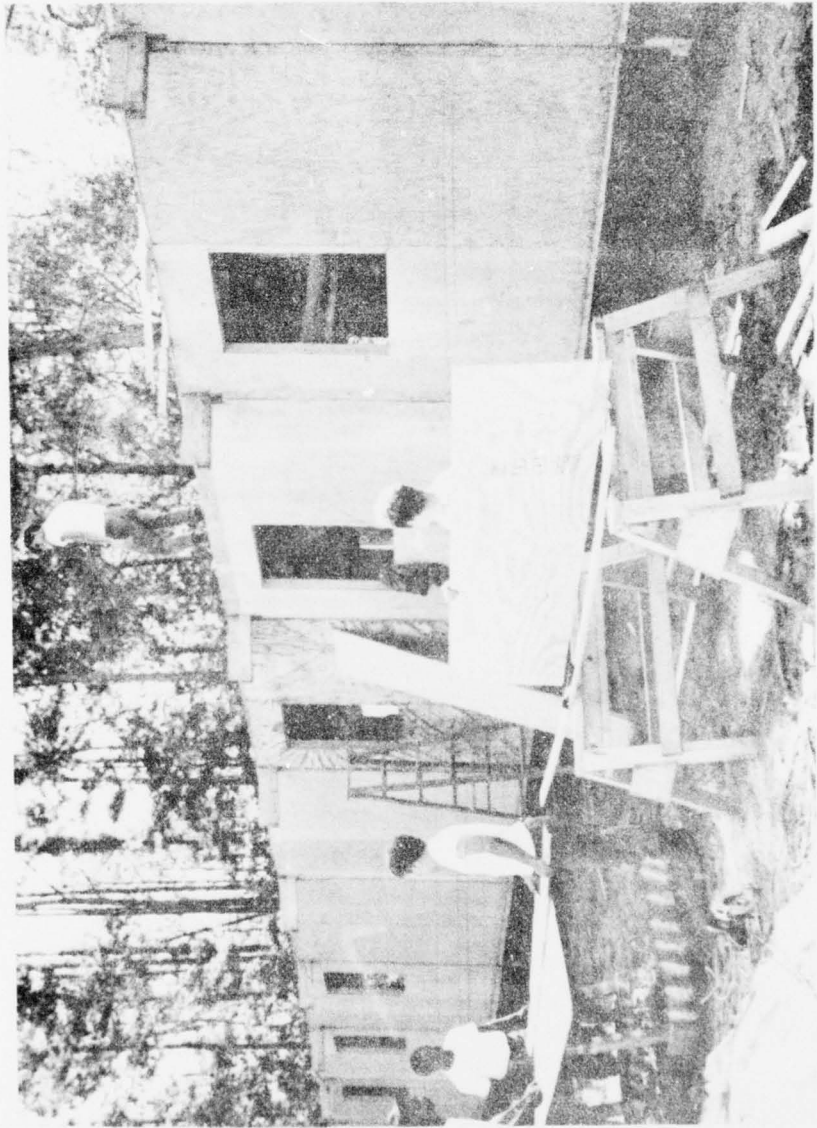

Figure A5. Wall panels.



Figure A6. Roof panels being installed.



Figure A7. Completed building interior before finishing.

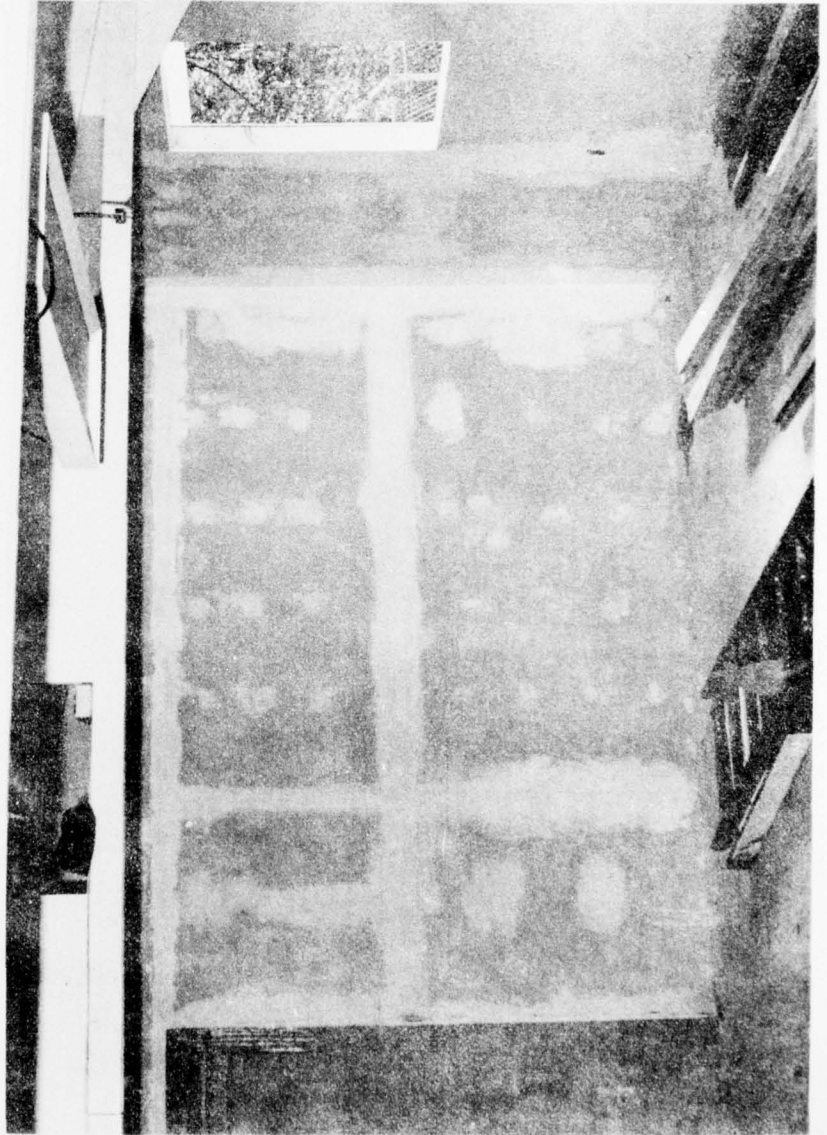

Figure A3. Interior walls covered with 5/8-in. (1.59-cm) gypsum boards.



Figure A9. Completed building interior.

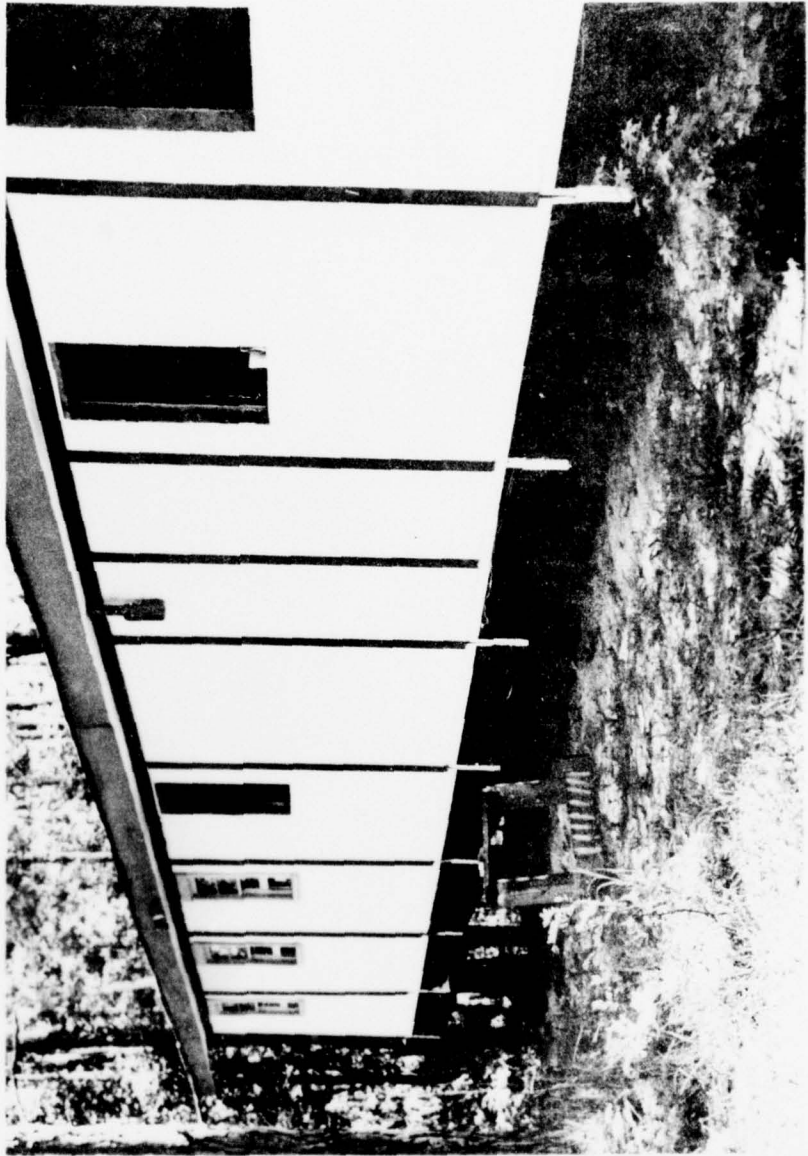

Figure A10. Exterior view showing sloping grade.



Figure A11. Completed stairway at rear of building.

Table A1

Comparison of Construction Cost, Labor, and Logistic Data  
Between Fort Belvoir Building and AFCS Facility 3403

	Material Cost <sup>a</sup> \$/sq ft (\$/m <sup>2</sup> )	Labor Requirements	Logistic Data STON	MT
Fort Belvoir Bldg 24 X 40 ft (7.32 X 12.12 m)	\$2.29 (\$24.65)	290 MH	11.4	20.5
AFCS Facility 3403 <sup>b</sup> 960 sq ft (89.2 m <sup>2</sup> )	\$2.32 (\$24.97)	556 MH	11.8	26.2

- a. Unit cost of each material item is based on Sept 76 SIMF Listing. Polyurethane was excluded from calculation for the Fort Belvoir building.
- b. Consists of Facilities 340321, 340322, 340361, and 340374. Material cost, labor, and logistic requirements were calculated based on 20 X 40 ft (6.06 X 12.12 m) building, then adjusted to 960 sq ft (89.2 m<sup>2</sup>) building.

Table A2

Summary of Construction Cost and Labor Data

	Material Cost <sup>a</sup>	Labor Requirement	Total Cost <sup>c</sup>	Cost per Sq Ft (m <sup>2</sup> )
Fort Rucker 24 x 80 ft (7.32 X 24.24 m)	\$11,349	927 MH	\$14,918	\$7.77 (\$83.64)
Fort Belvoir 24 x 40 ft (7.32 X 12.12 m)	\$ 4,695 <sup>b</sup>	290 MH	\$ 5,812	\$6.05 (\$61.12)

<sup>a</sup>Actual cost of one building including polyurethane foam, gypsum board (3/8 in. at Belvoir and 5/8 in. at Rucker), and preassembled double-hung windows at Rucker.

<sup>b</sup>Includes cost of materials to field fabricate windows not provided in Fort Belvoir test.

<sup>c</sup>Labor costs were uniformly set at \$3.85 per hour for all military skills and pay grades.

ANNEX: USER EVALUATION OF FORT RUCKER BUILDING

DEPARTMENT OF THE ARMY  
COMPANY B, 46TH ENGINEER BATTALION (COMBAT)(HEAVY)  
FORT RUCKER, ALABAMA 36362

AFFR-EB-B

7 Oct 76

SUBJECT: Evaluation of CERL Building

Mr Kao:

Enclosed are the statements of my senior carpenters concerning the erection of the CERL building. Each is a highly skilled craftsman whose comments deserve careful consideration. I am currently on TDY status for a demolition project in Aliceville Alabama and although the majority of my figures and notes concerning the building have been forwarded, some remain at Fort Rucker where I will forward them to you upon my return.

Working on this project was a challenge and a pleasure. Many skeptics of the polyurethane foam have been totally converted. My only concern is that of the feasibility of acquiring such capabilities to apply the foam should the building have to be built from scratch. Obviously, delivery as we received would eliminate this concern.

The construction sequence and methods called for in the booklet you provided were followed as closely as possible, (even when the carpenters disagreed) and any discrepancies are as noted.

The absence of a numbered sawing template impeded the bent construction. This also proved to be the most difficult aspect of the job, and the alternate concrete foundation deserves consideration.

Minor problems were encountered with the installation of the doors and windows due to the openings provided in the panels and the framing plans.

The installation of the floor panels, walls, roof trusses, and roof panels was quite simple and quickly accomplished. Some of this work was done at night. Most of the time only a few carpenters were on site to supervise the other workers (truck drivers, masons, electricians, plumbers), who improved their skills as the project progressed.

The major problems encountered concerned the construction and installation of the bents, and the "finish" work - door and window frames, overhangs, battens, etc.

SUBJECT: Evaluation of CERL Building

Many of the suggestions and considerations throughout construction were not tailored to the fact that this is a Theater of Operations building (with a generally temporary lifespan) and was designed as such.

My major concern with the building concerns the foam insulation and the capability to insure a safe, non-fire hazard structure. The overall erection (as with most prefab structures) was relatively fast simple. Problem areas (as mentioned) warrant inspection in order to improve the final structure design and erection procedures. This building concept deserves consideration as an addition to the Army's inventory provided the problem of fireproofing can be solved.

If I can be of any further assistance please contact me:

2LT PATRICK W P LISOWSKI  
CMR 1 BOX 18381  
FT RUCKER, AL 36362

I am sorry I was not able to meet you at the project site, I appreciate the opportunity to participate in this project. It was very beneficial to me and my platoon and I hope the results are beneficial to you.

*Patrick W P Lisowski*

PATRICK W P LISOWSKI  
2LT CE  
B Co, 46th Engr Bn

## REFERENCES

- American Society for Testing and Materials, "Standard Methods for Establishing Clear Wood Strength Values" Annual Book of ASTM Standards D2SSS-76 (1976).
- Department of the Army, Army Facilities Components System - Planning, TM5-301; Army Facilities Components System - Design, TM5-302; Army Facilities Components System - Logistic Data and Bills of Materials, TM5-303 (1973).
- Headquarters, Department of the Army, Construction Management, TM5-333 (February 1972).
- Heidersbach, R. H., Jr., Wood Design Parameters for Theater of Operations Applications, Technical Report M-80/AD#780800 (CERL, 1974).
- Kao, A. M., and J. Cook, Alternative Theater of Operations Building Systems: Progress Report, Special Report C-80/ADA042312 (CERL, 1977).
- Kao, A. M., T. M. Whiteside, A. Smith, and R. L. Trent, Prefabricated Expandable Foam/Wood Structure for the Theater of Operations, Interim Report C-45/ADA044991 (CERL, 1977).
- Kao, A., and J. Cook, Preliminary Design and Construction Guidelines for Vertical Construction in Desert and Tropical Theaters of Operations, Interim Report C-74/ADA032124 (CERL, 1976).
- The Structural Engineering Systems Solver User Manual (Department of Civil Engineering, University of Illinois, Urbana, IL, 1968).
- Trent, R. L., T. M. Whiteside and J. Robertus, Erection Procedures for Prefabricated Expandable Foam/Wood Structure, Technical Report C-52/ADA027382 (CERL, 1976).
- Trent, R. L., T. M. Whiteside, and J. Robertus, Field Experiment on a Prefabricated Expandable Foam/Wood Structure, Interim Report C-50/ADA032726 (CERL, 1976).
- U.S. Army Engineer School, Pre-engineered Logistic and Administrative Structures (PLAST) (16 August 1973).

CERL DISTRIBUTION

Chief of Engineers  
ATTN: DAEN-ASI-L (2)  
ATTN: DAEN-MPR  
ATTN: DAEN-ZCM/E. McWhite  
Dept of the Army  
WASH DC 20314

46th Engr Battalion (Combat)(Heavy)  
ATTN: MAJ G. S. Pincince  
Ft. Rucker, AL 36362

U.S. Army Health Facility Planning Agency  
ATTN: MAJ David Kitchen  
Pentagon, Rm 2C468  
WASH DC 20310

U.S. Army Engr School (USAES)  
ATTN: D-E/S  
Ft. Belvoir, VA 22060

U.S. Army/FESA  
Bldg 358  
Ft. Belvoir, VA 22060

Defense Documentation Center  
ATTN: DDA (12)  
Cameron Station  
Alexandria, VA 22314

Kao, Anthony M

A family of components for the wood panelized prefabricated building system /  
A. M. Kao, T. M. Whiteside.--Champaign, IL : Construction Engineering Research  
Laboratory ; Springfield, VA : available from NTIS, 1979.  
65 p. : ill. ; 27 cm. (Special report ; M-255)

1. U.S. Army-military construction operations. 2. Buildings, prefabricated.  
I. Whiteside, Thomas M. II. Title. III. Series: U.S. Construction Engineering  
Research Laboratory ; Special report ; M-255.

**DEPARTMENT OF THE ARMY**

CONSTRUCTION ENGINEERING RESEARCH LABORATORY

CORPS OF ENGINEERS

P. O. BOX 4005

CHAMPAIGN, ILLINOIS 61820

OFFICIAL BUSINESS

PENALTY FOR PRIVATE USE \$300

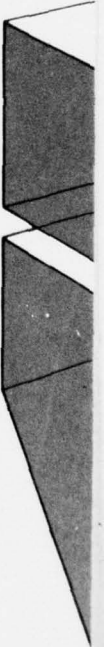

POSTAGE AND FEES PAID  
DEPARTMENT OF THE ARMY

DOD - 314



THIRD CLASS