

AD-A065 830

BIORESEARCH INC FARMINGDALE NY  
DEVELOPMENT OF AN ENZYMIC ELECTRODE OIL IN WATER SENSOR. (U)  
JAN 79 A M CUNDELL, N J PATNI, E FINDL  
ER-013179

F/G 13/2

N00014-78-C-0230

UNCLASSIFIED

NL

| OF |  
AD  
A065830



END  
DATE  
FILMED  
5-79  
DDC

12 LEVEL II

AD A0 65830

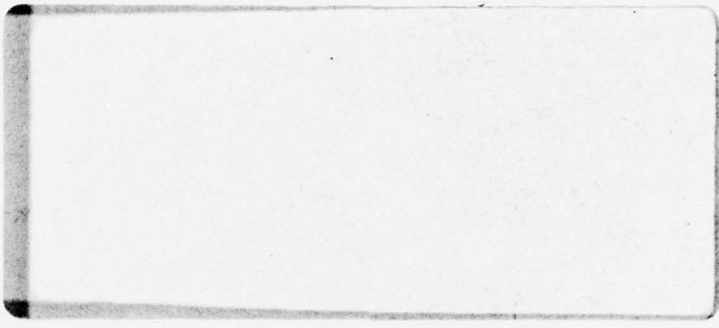

DDC FILE COPY

DDC  
RECEIVED  
MAR 16 1979  
B

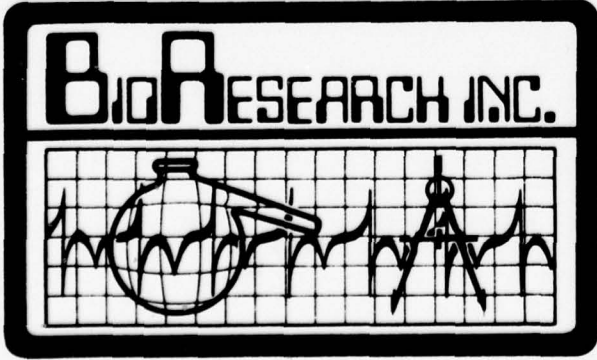

DISTRIBUTION STATEMENT A  
Approved for public release;  
Distribution Unlimited

79 03 06 109

12

LEVEL II

ADA065830

DDC FILE COPY

ER-013179  
Final Report  
Development of an Enzymic  
Electrode Oil in Water Sensor  
January, 1979

Prepared under:  
Contract N 00014-78-C-0230

Prepared for:

1. David W. Taylor Naval Ship Research  
& Development Center  
Annapolis, Md. 21402
2. Office of Naval Research  
Arlington, Virginia  
22217

Prepared by:

BioResearch, Inc.  
315 Smith Street  
Farmingdale, N.Y.  
11735

DDC  
RECEIVED  
MAR 16 1979  
B

DISTRIBUTION STATEMENT A  
Approved for public release  
Distribution Unlimited

79 03 06 109

<p>(14) <b>REPORT DOCUMENTATION PAGE</b></p>		<p><b>READ INSTRUCTIONS BEFORE COMPLETING FORM</b></p>
1. REPORT NUMBER	2. GOVT ACCESSION NO.	3. RECIPIENT'S CATALOG NUMBER
ER-013179		(9)
4. TITLE (and Subtitle)		5. TYPE OF REPORT & PERIOD COVERED
<p>(6) DEVELOPMENT OF AN ENZYMIC ELECTRODE OIL IN WATER SENSOR.</p>		Final Report. Mar 1, 1978 to Dec 1978
		6. PERFORMING ORG. REPORT NUMBER
7. AUTHOR(s)		8. CONTRACT OR GRANT NUMBER(s)
<p>(10) A.M./Cundell, N.J./Patni, E./Findl</p>		<p>(15) N 00014-78-C-0230</p>
9. PERFORMING ORGANIZATION NAME AND ADDRESS		10. PROGRAM ELEMENT, PROJECT, TASK AREA & WORK UNIT NUMBERS
<p>BioResearch, Inc. 315 Smith Street Farmingdale, N.Y. 11735</p>		737572
11. CONTROLLING OFFICE NAME AND ADDRESS		12. REPORT DATE
<p>Office of Naval Research 800 N Quincy Street Arlington, Va. 22217</p>		(11) 31 January 1979
14. MONITORING AGENCY NAME & ADDRESS (if different from Controlling Office)		13. NUMBER OF PAGES
<p>(12) 29 p.</p>		15. SECURITY CLASS. (of this report)
		Unclassified
16. DISTRIBUTION STATEMENT (of this Report)		15a. DECLASSIFICATION/DOWNGRADING SCHEDULE
<p>UNLIMITED DISTRIBUTION</p>		<p><b>DISTRIBUTION STATEMENT A</b> Approved for public release; Distribution Unlimited</p>
17. DISTRIBUTION STATEMENT (of the abstract entered in Block 20, if different from Report)		
18. SUPPLEMENTARY NOTES		
19. KEY WORDS (Continue on reverse side if necessary and identify by block number)		
<p>ENZYME ELECTRODE BACTERIAL ELECTRODE OIL POLLUTION</p>		
20. ABSTRACT (Continue on reverse side if necessary and identify by block number)		
<p>Development of a hydrocarbon dioxygenase electrode oil-in-water sensor was undertaken to detect low concentrations of petroleum hydrocarbons (&lt;100ppm) dissolved in bilge water. Candidate microorganisms, which produce the dioxygenases, were chosen for their ability to oxidize aliphatic and aromatic hydrocarbons. Two organisms, the bacterium <u>Pseudomonas putida</u> and the yeast <u>Candida intermedia</u> were cultivated in the laboratory on</p>		

393 778

B

naphthalene and in n-hexadecane respectively. Experiments were run to establish optimum growth conditions for high cell yields and high hydrocarbon dioxygenase activity.

Cell yields of up to 1 g/dry wt/day were obtained with the Pseudomonas putida. Maximum naphthalene dioxygenase concentrations occurred during the early growth phase. The best compromise between enzyme activity and cell yield were obtained after 8 hours of cultivation.

A dual electrode oil-in-water sensor was designed and constructed. Suspensions of naphthalene-grown Pseudomonas putida were placed in front of the electrode membrane of a commercial oxygen probe. Preliminary tests indicated a high endogenous respiration and relatively low enzyme activity of the bacterial cells.

ACCESSION for	
NTIS	White Section <input checked="" type="checkbox"/>
DDC	Buff Section <input type="checkbox"/>
UNANNOUNCED	<input type="checkbox"/>
JUSTIFICATION _____	
BY _____	
DISTRIBUTION/AVAILABILITY CODES	
Dist.	SPECIAL
A	

## TABLE OF CONTENTS

	Pages
Foreward	1
Abstract	2
Introduction	3
Technical Discussion	4
Bacterial and Enzyme Aspects	4
Petroleum Hydrocarbons Found in Bilge Water	4
Selection of Microorganisms	5
Organisms and Growth Conditions	5
Assay of Dioxygenase Activity	10
Assay of the Decane Oxidizing System in Candida	12
Electrode and Instrumentation Aspects	13
General Considerations	13
Design of Test Apparatus	14
Preliminary Test Results	18
Conclusion and Recommendations	20
References	22
Standard Distribution List	23

## FOREWARD

This report was prepared by BioResearch, Inc. for the David W. Taylor Naval Ship R & D Center (DTNSRDC) Annapolis, MD and the office of Naval REsearch (ONR) in accordance with the requirements of Contract No. N 00014-78-C-0230. The first phase contract period was initially scheduled to be March 1, 1978 to February 28, 1979. However, the project was prematurely terminated, due to Naval Material Command pollution control FY 1979 funding cuts. This report describes the progress to December 22, 1978.

The objective of the program is to develop an electrochemical sensor based on the operation of a hydrocarbon oxygenase enzyme electrode in a constant temperature flow-through chamber that can detect oil in bilge water in the concentration range of 15 to 100 ppm.

The program was conducted by the Bioelectrochemistry Division of BioResearch, Inc.; manager was E. Findl. Other personnel working on the program were Dr. A.M. Cundell, N.J. Patni and Dr. H. Guthermann.

Principal technical monitors for the program were Dr. S. Finger (DTNSRDC) and Dr. A. Emery, Jr. (ONR). Their assistance and guidance is gratefully acknowledged.

## ABSTRACT

Development of a hydrocarbon dioxygenase electrode oil-in-water sensor was undertaken to detect low concentrations of petroleum hydrocarbons (<100ppm) dissolved in bilge water. Candidate microorganisms, which produce the dioxygenases, were chosen for their ability to oxidize aliphatic and aromatic hydrocarbons. Two organisms, the bacterium Pseudomonas putida and the yeast Candida intermedia were cultivated in the laboratory on naphthalene and n-hexadecane respectively. Experiments were run to establish optimum growth conditions for high cell yields and high hydrocarbon dioxygenase activity.

Cell yields of up to 1 g/dry wt/day were obtained with the Pseudomonas putida. Maximum naphthalene dioxygenase concentrations occurred during the early growth phase. The best compromise between enzyme activity and cell yield were obtained after 8 hours of cultivation.

A dual electrode oil-in-water sensor was designed and constructed. Suspensions of naphthalene-grown Pseudomonas putida were placed in front of the electrode membrane of a commercial oxygen probe. Preliminary tests indicated a high endogenous respiration and relatively low enzyme activity of the bacterial cells.

## INTRODUCTION

Environmental criteria for coastal waterways have been established limiting the maximum concentration of oil in ship overboard discharge streams to 100 ppm of oil. Ongoing research at various Navy and Coast Guard facilities has indicated that there are inadequacies in presently available chemical analysis instrumentation needed to monitor discharge streams aboard sea-going vessels. These inadequacies primarily center on interference problems, maintenance problems, operational complexity and high cost.

Discussions with cognizant pollution control personnel at the U.S. Naval Ship Research & Development Center, Annapolis, Md., stimulated interest in BioResearch personnel to develop a solution to the instrumentation problem. As a result, an in-house program was initiated, with corporate funding. This program resulted in a novel device concept which can, with suitable development, provide the Navy and Coast Guard with an instrument for oil-in-water detection that will eliminate all of the inadequacies previously noted. The concept is the use of a hydrocarbon oxygenase enzyme electrode.

Preliminary testing of the concept was accomplished at the University of Tennessee, utilizing bacterial protein fractions, containing appropriate enzymes, in conjunction with commercial oxygen electrodes.

Although the principle of an enzymic electrode for oil in water detection appears feasible, much remains to be accomplished before the concept can be turned into an instrument for general usage by Naval personnel.

The project has as its objective a research effort that will lead to the electrochemical sensor that will meet or better the following specifications:

1. Detect oil in water in the range 15-100ppm.
2. Particulates, extraneous materials, biological fouling and detergents to have minimal effect on the sensor. Such effect to be less than 3% or 1 ppm oil, whichever is greater.
3. Routine maintenance of sensor and readout instrumentation to be accomplished in 1 hour or less, at a frequency of once per 30 or more days. Routine maintenance to be such as can be handled by non-technical Naval personnel.
4. Sensor sensitivity to variation of oil type to be less than 5% or 2ppm (whichever is greater) when measuring gasoline, diesel fuel, lubricating oil or fuel oil in the 15-100 ppm range.

## TECHNICAL DISCUSSION

The enzyme electrode oil-in-water sensor development effort was divided into two principal task areas. One dealt with the bacterial and enzyme aspects of the sensor. The other dealt with the electrode and instrumentation aspects of the effort. This division of program tasks is reflected in the following discussion.

### Bacterial and Enzyme Aspects

As the term enzyme electrode implies, the key element in developing this specific type of electrode sensor is the enzyme or groups of enzymes that provide the specificity needed. In the case of the oil-in-water electrode, the enzymes are found in microorganisms that utilize hydrocarbons as carbon sources for growth and energy production. Such organisms, through various oxidation pathways, combine hydrocarbons with oxygen to ultimately produce CO<sub>2</sub> and energy. The enzymes that produce the initial oxidation step are generally dioxygenases that directly combine O<sub>2</sub> with the hydrocarbons.

Details of the process used in the selection of the microorganisms most likely to be useful for an enzyme electrode for the detection of oil in bilge water, follow. In addition, details of the methodologies used to culture the selected organisms and to evaluate enzymic activity are presented.

### Petroleum Hydrocarbons Found in Bilge Water

Petroleum hydrocarbons, found in bilge water, are derived from fuel and lubricating oils consumed within naval vessels. The composition of these petroleum products are complex but can be represented by a) n-alkanes, {C<sub>11</sub>-C<sub>32</sub>}, b) alkylated benzenes, {C<sub>2</sub>-C<sub>4</sub> benzene}, c) alkylated naphthalenes, {C<sub>1</sub>-C<sub>2</sub>}, d) branched chain alkanes, e) cycloparaffins and f) asphaltenes. Typically, when spilled hydrocarbon fuels contaminate bilge water, the lower boiling point fractions are lost by evaporation, lower molecular weight alkanes, benzene and naphthalene derivatives dissolve in the water, and the higher molecular weight hydrocarbons remain in suspension or are adsorbed to particulate material within the bilge (Zurcher & Thuer, 1978). Residual petroleum, in suspension, can be removed by oil-in-water separators, while the water soluble fractions may be discharged into the surrounding water. The water-soluble fraction includes such hydrocarbons as benzene, toluene, ethylbenzene, xylene, C<sub>3</sub> benzene, C<sub>4</sub> benzene, naphthalene, methyl naphthalene, C<sub>2</sub> naphthalene, and n-alkanes C<sub>11</sub>-27.

## Selection of Microorganisms

The selection approach deemed most suitable was to investigate microorganisms with a hydrocarbon substrate specificity similar to the hydrocarbons found in the water soluble fractions of the fuel oil.

An extensive literature survey was made to discover the most suitable microorganisms. Unfortunately the literature revealed that there are no microorganisms that have been identified with the ability to grow on a wide range of hydrocarbons, e.g., n-alkanes, isoalkanes, cycloparaffins, aromatic hydrocarbons, etc.. Considerable effort was expended (with only partial success) by Chakrabarty and his coworkers, (Friello and Mylroie) to genetically engineer such a strain of the bacterium Pseudomonas aeruginosa (Friello et. al., 1976). Transmissible plasmids for the salicylate, toluene, octane and camphor degradative pathways can be inserted into a candidate bacterium to increase its ability to degrade petroleum hydrocarbons.

Selection of candidate microorganisms was guided by the following criteria;

- 1) the hydrocarbon substrate requirement of the microorganisms should be as wide as possible and include petroleum hydrocarbons found to be water soluble,
- 2) a pure culture of the microorganisms should be available,
- 3) the microorganisms should be readily cultivated within our laboratory, and
- 4) some information on the enzymology of the candidate microorganism should be contained in the literature.

## Organisms and Growth Conditions

Organisms for preliminary screening of their hydrocarbon utilizing ability were selected and ordered from different culture collection centers or were obtained from individual research groups. The organisms and their sources are listed in Table I. Strains from Dr. D.T. Gibson, University of Texas, Austin, especially the organism Pseudomonas putida, were considered good candidates because of the elegant work Gibson and his coworkers had conducted on their naphthalene oxygenase system (Patel and Gibson, 1974; Jeffrey et.al., 1975).

Pseudomonas aeruginosa and P. putida strains were maintained

TABLE 1

Hydrocarbon-utilizing microorganisms selected for screening

<u>Organism</u>	<u>Source and Number</u>	<u>Substrate Specificity based on literature</u>
<u>Pseudomonas putida</u>	ATCC-17484	Aromatic Hydrocarbons
<u>Pseudomonas aeruginosa</u>	NRRL-1783 -1784 -1785	Naphthalene
<u>Pseudomonas aeruginosa</u>	NRRL-B 5472	Aromatic and aliphatic hydrocarbons
<u>Pseudomonas putida GN</u>	Dr. Gibson Univ. of Texas	Aromatic hydrocarbons
<u>Pseudomonas putida GT</u>	Dr. Gibson	Aromatic hydrocarbons
<u>Candida intermedia</u>	NRRL-Y6328-1	Aliphatic hydrocar- bons

and grown in Stanier's medium (Stanier et. al. 1966). Candida intermedia was grown in the medium described by Liu & Johnson (1971). To screen the hydrocarbon utilizing ability of the microorganisms, the inoculum was prepared in a similar medium containing 0.2% glucose. The flasks were incubated overnight at room temperature on a rotary shaker with a speed of 150 RPM. The culture was centrifuged aseptically in a Beckman J-20 centrifuge at 10,000 RPM for 15 minutes. Cells were washed twice with sterile distilled water and resuspended in same, to a known optical density. Known amounts of cell suspension were added in different flasks containing 30 or 50 ml medium to give the final optical density of 0.01 at 580 nm. Hydrocarbons, used for screening, were supplied in the vapor phase with the help of glass tubes which were sealed at both ends and were modified for addition of hydrocarbons as substrate. A rubber stopper was inserted on one side of the tube. It was used to seal the flasks. Non-volatile hydrocarbons, like hexadecane or lube oil, were added directly into the medium at a concentration of 0.1% (v/v). Solid hydrocarbons were dissolved in alcohol and supplied as a vapor with alcohol alone as a control. Flasks were incubated at room temperature on a rotary shaker at 150 RPM for 3 to 7 days. Growth was measured as optical density at 580 nm in a Spectronic 20 spectrophotometer.

All P. aeruginosa strains NRRL, except strain B-5472, grew only on naphthalene. Strain B-5472 was able to use n-hexadecane, methyl naphthalene and petroleum ether as a source of carbon and energy. P. putida strains GN and GT grew best on naphthalene and toluene. Strain GT was able to use hexadecane and fuel oil, after 7 days of incubation, but the growth was only about 25% of the growth on naphthalene or toluene. Addition of 0.1% non-ionic detergent to the medium containing hexadecane or fuel oil resulted in more growth within 4 days as compared to culture grown in the substrates alone. However, this difference in the growth was overcome when the culture was incubated longer (7 days). None of the Pseudomonas strains were able to use benzene, methyl cyclohexane, methyl naphthalene, lube oil, or non-ionic detergent for growth.

Candida intermedia was able to grow on hexadecane and fuel oil. None of the other hydrocarbons were investigated as substrates for growth. Addition of non-ionic detergent to hexadecane was found to inhibit the growth of Candida intermedia. Tween 20 or Tween 80 had no effect on the growth, when the culture was grown with hexadecane as substrate.

For mass culture, organisms were grown in a lift-fermenter (Bellco Glass Inc.) with forced aeration, or in a Multigen convertible bench top fermenter (Model F-200, New Brunswick Scientific Co., Inc.) with agitation and aeration. Six liter cultures were grown in the lift fermenter with forced aeration at a rate of 1 liter/min. for Pseudomonas and 5 liters/min. for Candida cultures. The fermenter bottle was kept in a waterbath to maintain the temperature at 28-30°C. Volatile hydrocarbons were provided as vapors, while non-volatile and solid substrates were added, at a concentration of 0.15%, directly in the medium.

Four hundred ml of 24 hr. old culture, grown in the presence of their respective hydrocarbon, was used as inoculum. A Multigen bench top fermenter was used to grow Pseudomonas strains. Maximum aeration and agitation, as recommended in the operation manual, was not sufficient to grow Candida intermedia in hexadecane. A single run with this organism and maximum allowable agitation and aeration resulted in the breakage of the fermenter jar. Pseudomonas putida GN was grown in 1.5 liters of medium containing 0.15% naphthalene. Medium was agitated at 500 RPM and air was passed at the rate of 1 liter/min. Forty ml of 24 hours old culture was used as inoculum. The fermenter was maintained between 28°-30°C.

In almost all cases, growth was represented as mg. dry wt. of cells/liter of culture. For the dry weights, a known aliquot of culture was centrifuged at 10,000 RPM for 15 min. Cells were washed twice with distilled water to remove any residual hydrocarbon adsorbed on the cells. Cells were suspended in distilled water and then dried for 24-48 hours at 65°-70°C until constant weight was achieved.

When the microorganism were grown in the lift fermenter, there was almost a linear increase in growth for about 3 to 4 days. Stirring the culture was found to markedly increase growth. The Pseudomonas putida GN strain produced a cell yield of about 0.5 gm/liter in 3 days, when the culture was agitated using a magnetic stirrer. This was about 4 times the growth achieved in a culture which was not mixed. The GT strain always gave a lower cell yield compared to the GN strain. This may be because there was no way to monitor the final concentration of toluene in the medium in the system used.

In the case of Candida intermedia, there was a linear increase in the cell yield for about 7 days (approximately 2.0 gms dry wt. of cells/liter with a culture mixed by magnetic stirrer). Growth was found to level off after 7 days of incubation, even though hexadecane was still present in the medium, suggesting suboptimum conditions of growth.

With the Pseudomonas putida GN strain, it was found that temperature and agitation of the medium played a very important role in maximum growth of the culture (Table 2). There was about a four-fold difference in growth between stirred and non-stirred culture. Also, constant temperature resulted both in faster growth and more total growth of the organism. When grown in the Multigen bench top fermenter, with constant temperature, agitation and aeration, a growth of approximately 0.9 to 1.0 gm. dry wt. of cells/liter was obtained within 24 hours.

Based on these results Pseudomonas putida GN and Candida intermedia were used for later experiments.

TABLE 2

Effect of Temperature and Agitation on Growth of P. putida GN  
on Naphthalene in 3 Days

<u>Conditions of Growth</u>	<u>Gms dry wt. cells/liter</u> <u>of Culture</u>
Rotary shaker, 150 RPM, temperature variable	0.19
Rotary shaker, 150 RPM, temperature constant (23°-24°C)*	0.35
Lift-fermenter-aeration, no agitation, temperature constant	0.12
Lift fermenter- aeration, no agitation, constant temperature	0.56
Lift fermenter- aeration, agitation and constant temperature +	0.47
Multigen fermenter-aeration*, agitation and constant temperature	0.98

Naphthelene was added at 0.15% concentration.

Aeration was at rate of 1 liter/min.

+ Culture was grown in medium of Patel and Gibson (1974).

\* Growth was measured after 1 day of incubation.

### Assay of Dioxygenase Activity

Detection of naphthalene dioxygenase activity in cell extracts or in whole cells was accomplished by measuring oxygen consumption at 37°C, with a YSI oxygen probe, using the method of Jeffrey et. al. (1975). The reaction mixture for the whole cell assay contained; whole cell suspension (0.1 - 0.2 ml; OD at 580 nm = 1.0), 100 nanomoles naphthalene in alcohol, 0.7  $\mu$ moles of NADH and 50 mM of air saturated sodium phosphate buffer (pH 7.5), in a total volume of 3 ml. In later experiments, alcohol was substituted with N<sub>1</sub>N-dimethyl formamide (DMF) to dissolve naphthalene, and phosphate buffer was substituted with tris-hydrochloride buffer (pH 7.5). DMF did not inhibit the dioxygenase activity.

Results of measurements are presented on Table 3. Rate of reaction was found to be linear, under the assay conditions as shown thereon one unit of enzyme activity was defined as the amount of enzyme that consumed one nanomole of oxygen per minute. Activities were expressed as units per milligram dry weight of cells. Specific activities were expressed as units per milligram of protein.

The medium type was found to effect dioxygenase activity. The activity in the cells grown in Patel and Gibson medium was about 3 times less than that of cells grown in Stanier's medium. As expected, cells grown in naphthalene had more activity than cells grown in toluene. Dithiothreitol (DTT) was found to activate the naphthalene oxygenase activity, under the assay conditions used.

A discussion with members of Dr. D.T. Gibson's laboratory, held at the University of Texas at Austin, suggested the use of early log phase cells for naphthalene oxygenase activity. To test this procedure, *Pseudomonas putida* GN was grown in the Multigen bench-top fermenter as described. Portions of culture were removed at 6, 12, and 24 hours. Results of a typical run, suggest that the 6 hour culture had more oxygen uptake activity and there was a continuous drop with age of the culture. Oxygen uptake activity was found to be 270, 100 and 11 nanomoles/min./mg. protein for 6, 12, and 24 hour culture respectively. This drop in the enzyme activity was confirmed, using cells from 8 hr. old cultures grown under similar conditions. Cell yield of such an experiment was found to vary from 0.13 to 0.17 gms. dry wt. cells per liter of culture. The specific activity, measured as total oxygen uptake, was between the range of 110 to 158 nanomoles/min./mg. protein. This was between the values obtained for 6 and 12 hour cultures. Naphthalene oxygenase activity was found to be associated with pigmentation. Only cultures exhibiting a pale green color were found to have detectable amounts of activity. Cultures having darker pigment had to be discarded. Naphthalene oxygenase activity was also found to be very unstable. About 50% loss in the activity was observed within 4 to 5 hours, when the enzyme (cell suspension) was kept at room temperature.

TABLE 3

Naphthalene Oxygenase Activity of Pseudomonas putida GN

Medium	Growth (hr.)	Type of Fermentor	Enzyme Activity units/min/mg. dry wt. cells
Stanier's	72	lift	1.83-2.5
Stanier's <sup>†</sup>	72	lift	0.75-1.12
Patel and Gibson	72	lift	0.62
	72	lift	1.23*
Stanier's	24	Multigen	12.7-17.5*

<sup>†</sup>Assay was done with P.putida GT cells grown in toluene.

\*Cell suspension preincubated with 5 mM dithiothreitol (DTT) before assay.

Almost all the activity was lost within three weeks when the enzyme was stored in the freezer at  $-20^{\circ}\text{C}$ .

#### Assay of the Decane Oxidizing System in *Candida*

Decane oxidation was assayed using cell extracts or whole cells by measuring the oxygen consumption at  $37^{\circ}\text{C}$  with a YSI oxygen probe. To prepare the cell extract, approximately 1 gm (dry wt.) of cells were suspended in 10 ml of 0.02M potassium phosphate buffer (pH 7.2) containing 0.5 mM of DTT. The cell suspension was sonified, using a Branson sonicator at 5-6 KHZ, for 20 min.. During sonication, the cell suspension was kept in ice, to maintain the temperature between  $0-5^{\circ}\text{C}$ . Cell suspensions were checked microscopically to confirm cell breakage, Cell debris and any unbroken cells were removed by low temperature centrifugation for about 30 minutes at 10,000 g. The clear supernatant was used as the enzyme source.

Decane oxidizing activity was determined by the method of Liu and Johnson(1971). In the routine assay, 2.0 ml of tris (hydroxymethyl aminomethane-hydrochloride buffer, 0.01 M, pH 8.9) was combined with 0.1 to 0.2 ml of whole cell suspension or crude extract. Water was added to a final volume of 3.0 ml. The reaction was started by adding an aqueous suspension of substrate ( $5 \times 10^{-4}\text{M}$ , final concentration of hexadecane). Since the solubility of hexadecane in water is very low, the substrate was sonically dispersed in distilled water immediately before use. One unit of the activity was defined as the amount causing uptake of one micromole of oxygen per hour. Specific activity is expressed as units per gram of cells. A very high endogenous oxygen uptake was observed in 72 hours old hexadecane-grown *Candida* cells. It was found to vary between 20-30  $\mu\text{moles/hr./gm.}$  of cells. Because of the high endogenous uptake, it was practically impossible to measure any change due to alkane oxidation activity. Using cell extract, the alkane oxidation activity was found to be approximately 7.0  $\mu\text{moles/hr./gm.}$  of cells. An activity of 18.46  $\mu\text{moles/hr./gm.}$  of protein has been reported by Liu and Johnson (1971) for *Candida intermedia* culture grown in hexadecane. On a per gram of cell basis, this activity would be still low. Hexadecane results in the induction of all three enzymes that oxidize decane, decanol and decanaldehyde (Liu and Johnson, 1971). On short term induction experiments, hexadecane was found to induce about four times more decanol dehydrogenase activity, as compared to decane oxidizing enzyme. Interrelationship of different enzymes to one substrate and very low activity of the first enzyme (in the present case - decane oxidizing) make the enzyme assay difficult.

### Electrode and Instrumentation Aspects

Two types of oxygen electrodes were initially considered for use in the program, i.e., the so-called fuel cell type and the Clark Type. Although neither type appears to have a clear cut advantage over the other, from a theoretical standpoint, the commercial availability of the Clark type made its use most attractive. Its selection was further buttressed by the commercial availability of instrumentation for the Clark electrodes that could be readily modified for our purposes.

Since most of the basic electrode and instrumentation components were "off the shelf" items, our efforts centered on modifying the electrodes and instrument to meet our requirements. Details of the modifications investigated, along with preliminary test results, are presented.

### General Considerations

The technology of enzyme electrodes was apparently initiated by Updike and Hicks (1967) with their development of a glucose detector incorporating glucose oxidase in an oxygen electrode. Since 1967, the number of enzyme electrodes reported in the literature has rapidly increased. Both potentiometric and amperometric devices have been employed with these electrodes. For oil in water detection, amperometric sensors, i.e., oxygen, oxygenase electrodes are the preferred type. More recently, Rechnitz (1978) has introduced a variation of the enzyme electrode, in which living, immobilized bacteria are used as the enzyme and coenzyme source.

One converts an oxygen sensor to a hydrocarbon sensor by adding a second "membrane" (containing a hydrocarbon di-oxygenase) to the electrode. The second membrane initiates and sustains a reaction between any hydrocarbons and the oxygen present in solution. The reaction, of course, occurs only at the oil-water-electrode interface. Since the oily water and dissolved oxygen are uniformly dispersed, the interface is also representative of the oxygen and oil concentrations in the bulk of the fluid. If no hydrocarbons are present, all of the oxygen that diffuses through the two membranes would reach the electrodes and be chemically (amperometrically) acted upon, giving a measurable quantity of current (microamps). If oil is present, a part of the oxygen will be reacted at the enzyme or bacterial layer and thus, not be available for amperometric / reduction. The difference between the quantity of oxygen (microamps) that would be reacted with no oil present and that with oil present, represents the quantity of oil present.

Measuring the oxygen concentration difference caused by the presence of oily waste is most easily done by incorporating two oxygen sensors in one housing. One of the sensors would include an enzyme or bacteria containing membrane. The second,

would include a similar membrane but without enzymes or bacteria. Thus, one electrode would measure oxygen as affected by the presence of oil, while the other electrode would be totally unaffected by the presence of oil.

### Design of Test Apparatus

A test apparatus, consisting of a constant temperature flow through chamber with dual oxygen electrodes mounted thereon, plus a differential oxygen concentration monitor, was fabricated. Details of the flow through chamber are presented on Figure 1. It consisted of an electrically heated aluminum block with a flow channel machined into the block. The dual oxygen electrodes were positioned into a chamber in the block through which heated, simulated bilge water was passed. Block temperature was regulated to achieve a 35°C water temperature by means of a thermistor modulated, electrical heater controller.

Initially, we utilized two YSI Model 57 oxygen monitors connected such that their outputs would provide us with a difference signal, as measured by a digital voltmeter. These units were later replaced by a YSI Model 53 oxygen meter that was electronically modified for dual electrode operation. A schematic of this revised instrument is presented in Figure 2.

In order to utilize either enzymes or bacteria with oxygen electrodes, it is essential that they be immobilized in some fashion at the oxygen membrane surface. There are many approaches that have been utilized to accomplish this task presented in the literature, ranging from entrapment behind membranes to cross-linking of the enzyme or bacteria to a membrane or other permeable surface. For our initial test purposes, it was decided to utilize the simplest approach, i.e., simply containing a liquid sample of the enzyme or bacteria in a small chamber sealed by a suitable membrane. We fabricated such chambers in the form of small volume cylinders as shown on Figure 3. It was necessary to choose a membrane material that was fully permeable to oxygen and hydrocarbon, had sufficient tensile properties to remain intact during fabrication and subsequent use, and was transparent to enable air bubbles to be readily seen within the chamber. A number of membranes were evaluated to determine their suitability to contain bacterial cells for the electrode sensor. Five criteria should be met by this outer membrane, namely:

- 1) high permeability to oxygen
- 2) high permeability to hydrocarbons
- 3) effective barrier to bacterial cells
- 4) sufficient tear strength to permit successful fabrication of the enzyme electrode and
- 5) transparency, so that any air bubbles between the membrane can be readily seen.

A summary of the trials with the different type of membranes is contained in Table 4.

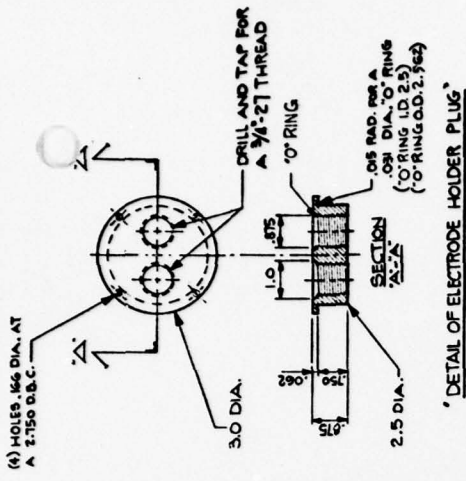

DETAIL OF ELECTRODE HOLDER PLUG

FLOW THRU CHAMBER  
FIGURE I

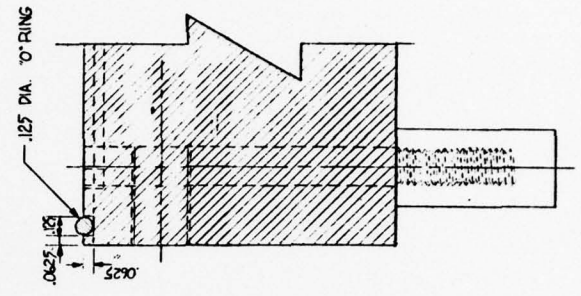

SECTION B-B  
SCALE - 2:1

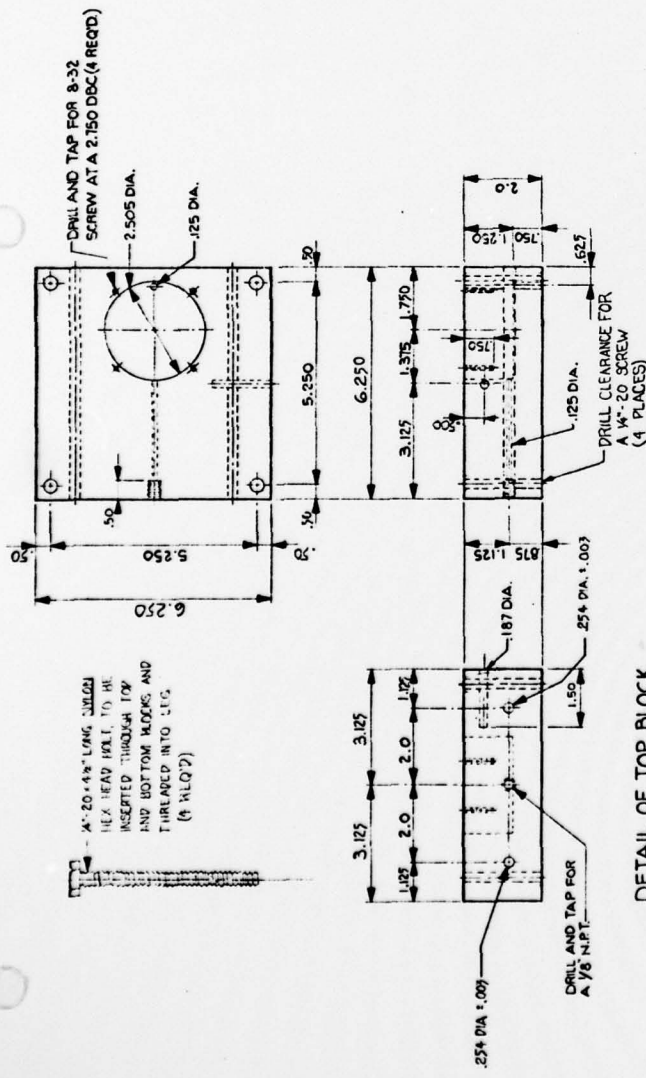

DETAIL OF TOP BLOCK

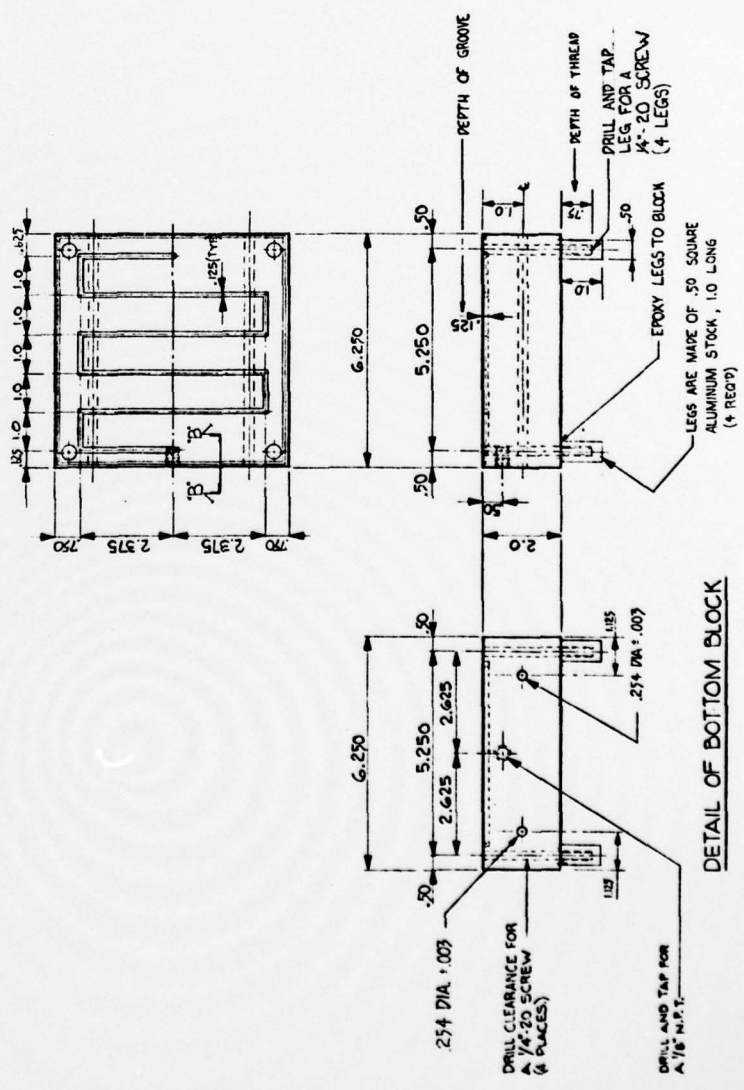

DETAIL OF BOTTOM BLOCK



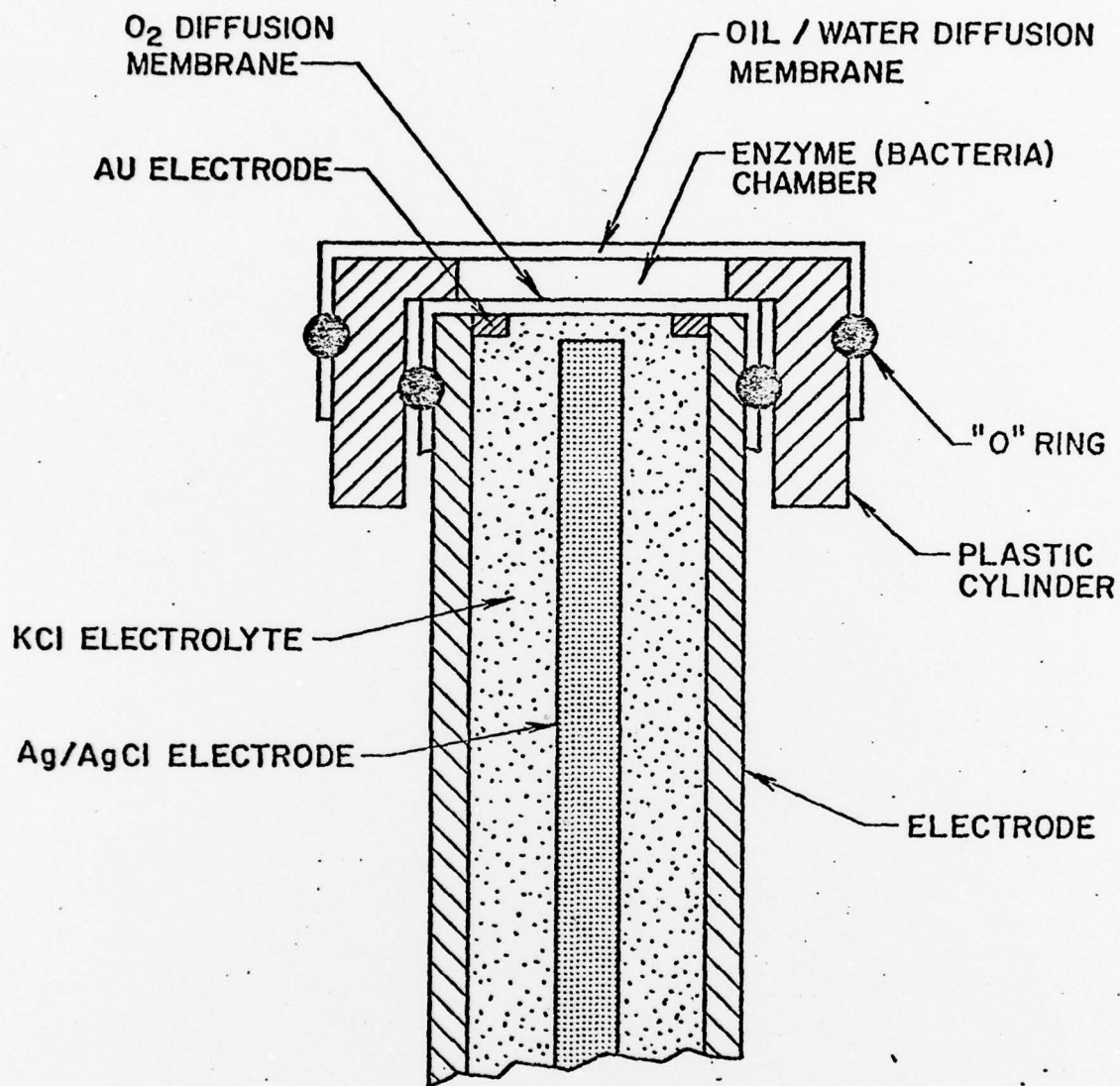

SCHMATIC DRAWING OF MODIFIED ELECTRODE  
WITH ENZYME /BACTERIA CHAMBER

FIGURE 3

TABLE 4  
TYPES OF MEMBRANE TESTED

Properties	Nucleopore Polycarbonate Membrane	Millipore Fluoropore Membrane	Non-Woven Polypropylene Laminate	Non-Woven Polyester Laminate	Dialysis Cellulose Acetate Membrane
Pore Size	0.2 $\mu$ m	5 $\mu$ m	0.45 $\mu$ m	3-5 $\mu$ m	Cutoff MW > 12,000
Reduction in Oxygen Reading	> 40%	> 30%	> 50%	> 45%	> 65%
Stability of Reading	Good-Fair	Good	Good	Good	Poor
Water Permeability	Good	Fair	Poor	Poor	Good
Tear Strength	Fair-Poor	Good	Good	Good	Good
Light Transparency	Good	None	None	None	Good

Of the membranes tested, none are completely satisfactory. Aside from transparency, the Fluoropore membrane seemed to be the most promising. The Nucleopore membrane tested was found to be acceptable in all categories except tear strength. We contacted the Nucleopore Corporation and were informed of the availability of another membrane having a similar pore size (0.2  $\mu\text{m}$ ) but having a somewhat greater thickness (15 vs 10  $\mu\text{m}$ ) and lower density of pores ( $10^7$  vs  $10^8$  pores/cm<sup>2</sup>). The tear strength of this latter type of membrane is purported to be significantly better than the type we tested. However, the reduced density of pores may further reduce O<sub>2</sub> diffusion.

Thickness of the layer of bacterial cells in the chamber is critical to the response time of the enzyme electrode. Response time was operationally defined as the time the oxygen probe and monitor took to register the drop from 90 to 10% saturation when the probe was transferred from an air-saturated water sample to an oxygen-depleted water sample. (Oxygen can be removed from a water sample either by bubbling nitrogen gas through the sample or by adding sodium bisulphite to chemically remove the oxygen.) Modified oxygen probes were constructed with response times of the order of a minute compared to 15 seconds for the unmodified probes.

Because of the vulnerability of the membrane material to both fouling and puncture during operation and the instability of the enzyme activity, we examined the possibility of immobilizing the bacterial cells within a thin permeable matrix. A report in the literature by Somerville, et. al., (1977) claimed that whole cells of Pseudomonas putida, immobilized on polyacrylamide gel, retain their ability to oxidize benzene for up to 30 days. Placement of a film of bacteria-containing gel in front of the electrode of the oxygen probe would seem a good solution to the construction of a responsive oil-in-water sensor. However, time constraints did not permit us to investigate this approach.

Another alternative method of electrode fabrication is to grow the Pseudomonas putida on a cellulosic type membrane, attaching them thereto by any of several techniques. The cellulose membrane is then placed in intimate contact with the oxygen membrane of the electrode and fastened thereon mechanically. Very preliminary tests using a sausage casing cellulosic membrane and one of the O<sub>2</sub> electrodes indicated that O<sub>2</sub> response times were not greatly affected by the addition of the second membrane.

#### Preliminary Test Results

During the period covered by this report, nearly all of the effort was expended on the microbiological aspects of optimizing growth of the selected cell types and the development of the

test apparatus. Only very preliminary testing was made with either enzymes or bacteria in conjunction with modified oxygen electrodes. In one set of preliminary experiments, conducted with microbial cell suspensions of Pseudomonas and Candida, cells were placed in the sample holder atop inverted oxygen electrodes. Microbial suspensions were placed in the cups. Into one of the cups, hydrocarbon solution was added (100 nanomoles). No difference in the oxygen uptake was noted. This was believed due to two factors. First, oxygen diffusion into the unstirred liquid in the electrode cup may be limiting. Second, the high endogenous oxygen consumption by the microbial cell suspension may be masking the oxygen consumption due to the oxidation of hydrocarbons.

In the second set of tests, an adaptor was constructed for the support of the outer nucleopore membrane which was used to trap the bacterial cells between the two membranes. A sample of naphthalene grown Pseudomonas putida, with a demonstrable naphthalene oxygenase activity, was placed in the chamber between the two membranes. The electrodes were placed in an air saturated buffer solution and a difference in the oxygen uptake was recorded to check for the endogenous activity. After about 5 minutes, a naphthalene solution, in DMF, was added to the air saturated buffer. No response was observed through the oxygen monitor. The run was repeated with different batches of cells, but in no case was any change in the oxygen uptake observed.

## CONCLUSIONS AND RECOMMENDATIONS

In our original projections made at the start of the program and presented in our program plan, the enzymic electrode oil-in-water sensor was to have been developed in a 2 year period. Based upon the originally projected program plan, everything was proceeding on schedule, at the time of project termination, due to Naval Material Command fiscal funding problem.

Overall, we made significant progress in the following areas;

1. Development of the instrumentation and test apparatus
2. Development of techniques to assay dioxygenase activity
3. Development of procedures to cultivate selected hydrocarbon-consuming microorganisms.

Preliminary runs with whole cell cultures and unpurified enzyme extracts were not successful. These initial negative results are typical of such R & D efforts. Therefore, it is as yet premature to state that the proposed sensor is practical or impractical.

In order to come to a rational conclusion regarding the practicality of the proposed sensor for naval applications, it will be necessary to reinitiate the research effort at the point it was halted. Since the original rationale for developing a cheap, reliable oil in water sensor for shipboard applications remains valid, it is recommended that the sensor development program be reinitiated as soon as funds are available.

REFERENCES

- Friello, D.A., J.R. Mylroie, and A.M. Chakrabarty 1976. Use of genetically engineered multi-plasmid microorganisms for rapid degradation of fuel hydrocarbons. Proc. 3rd International Biodegradation Symposium, P 205-215, Ed. J.M. Sharpley and A.M. Kaplan. Applied Science, London.
- Jeffrey, A.M., H.J.C. Yeh, D.M. Jerina, T.R. Patel, J.F. Davey and D.T. Gibson. 1975. Initial reactions in the oxidation of naphthalene by Pseudomonas putida. Biochemistry, 14: 575-584.
- Liu, C. and M.J. Johnson. 1971. Alkane oxidation by a particulate preparation from Candida. J. Bacteriol. 106: 830-834.
- Patel, T.R. and D.T. Gibson. 1974. Purification and properties of (+) -cis-naphthalene dihydrodiol dehydrogenase of Pseudomonas putida. J. Bacteriol. 119: 879-888.
- Rechnitz, G.A., 1978. Glutamine - selective membrane electrode that uses living bacterial cells. Science, Vol. 199, 440-441.
- Somerville, H.J., J.R. Mason, and R.N. Ruffell. 1977. Benzene degradation by bacterial cells immobilized in polyacrylamide gel. European J. Appl. Microbiol. 4:75-85.
- Stanier, R.Y., N.J. Palleroni and M. Doudoroff. 1966. The aerobic Pseudomonads: a taxonomic study. J. Gen. Microbiol. 43: 159-271.
- Udike, S.J. and G.P. Hicks. 1967. The enzyme electrode. Nature 214:986.
- Zurcher, F. and M. Thuer. 1978. Rapid weathering processes of fuel oil in natural waters: analyses and interpretations. Environ. Sci. & Technol. 12: 838-845.

OFFICE OF NAVAL RESEARCH  
NAVAL BIOLOGY PROJECT  
STANDARD DISTRIBUTION LIST

Number of Copies

( 12 )	Administrator, Defense Documentation Center Cameron Station Alexandria, VA 22314
( 3 )	Director, Naval Research Laboratory Attention: Technical Information Division Code 2627 Washington, D.C. 20375
( 1 )	Office of Naval Research Code 102D1 (ONRL DOC) 800 N. Quincy Street Arlington, VA 22217
( 3 )	Office of Naval Research Naval Biology Project Code 443 800 N. Quincy Street Arlington, VA 22217
( 1 )	Office of Naval Research Code 200 800 N. Quincy Street Arlington, VA 22217
( 1 )	Office of Naval Research Branch Office Building 114, Section D 666 Summer Street Boston, MA 02210
( 1 )	Director, Oceanic Biology Program (Code 484) Naval Ocean Research & Development Activity NSTL Station, MS 39529
( 1 )	Assistant Commander for Research & Develop- ment Code 03 Naval Facilities Engineering Command 200 Stovall Street Alexandria, VA 22332
( 1 )	Biological Sciences Staff (Code 104B) Naval Facilities Engineering Command 200 Stovall Street Alexandria, VA 22332

## STANDARD DISTRIBUTION LIST (Cont'd)

Number of Copies

- ( 1 ) Scientific Library  
Naval Biosciences Laboratory  
Naval Supply Center  
Oakland, CA 94625
- ( 1 ) National Environmental Research Center  
Edison Water Quality Research Division  
Edison, NJ 08817
- ( 1 ) Agricultural & Marine Pollution Control  
Branch  
Environmental Protection Agency  
1901 Fort Myers Drive  
Arlington, VA 22209
- ( 1 ) Technical Advisory Division  
National Marine Fisheries Service  
Department of Commerce  
Washington, D.C. 20235
- ( 1 ) Director  
Gulf Breeze Laboratory  
Environmental Protection Agency  
Sabine Island  
Gulf Breeze, FL 32561
- ( 1 ) Commanding Officer  
Navy Environmental Health Center  
3333 Vine St.  
Cincinnati, OH 45220
- ( 1 ) Naval Medical Research & Development Command  
Code 46  
National Naval Medical Center  
Bethesda, MD 20014
- ( 1 ) Commandant, DAT  
U.S. Coast Guard  
400 Seventh Street, SW  
Washington, D.C. 20511
- ( 1 ) Oceanographer of the Navy  
200 Stovall Street  
Alexandria, VA 22332
- ( 1 ) Commandant, DAS  
U.S. Coast Guard Research & Development Cntr.  
Avery Point  
Groton, CT 06340