

AD-A066 163

FOREIGN TECHNOLOGY DIV WRIGHT-PATTERSON AFB OHIO
ON THE SEPARATION OF FLOW AT THE EDGES OF ANTISYMMETRICAL DELTA--ETC(U)
JUL 78 E CARAFOLI, S STAIU

F/G 20/4

UNCLASSIFIED

FTD-ID(RS)T-0973-78

NL

| OF |
AD
A066163



END
DATE
FILMED
5-79
DDC

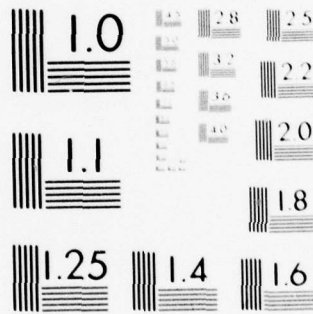

MICROCOPY RESOLUTION TEST CHART
NATIONAL BUREAU OF STANDARDS-1963-A

1

FOREIGN TECHNOLOGY DIVISION



ON THE SEPARATION OF FLOW AT THE EDGES OF ANTISYMMETRICAL
DELTA WINGS IN SUPERSONIC SYSTEM

By

E. Carafoli and S. Staicu



Approved for public release;
distribution unlimited.

AD-A066163

78 12 22 228

EDITED TRANSLATION

FTD-ID(RS)T-0973-78 14 July 1978

MICROFICHE NR: *FTD-78-C-000974*

CSP72052137

ON THE SEPARATION OF FLOW AT THE EDGES OF
ANTISYMMETRICAL DELTA WINGS IN SUPERSONIC
SYSTEM

By: E. Carafoli and S. Staicu

English pages: 30

Source: Studii Si Cercetari De Mecanica
Aplicata, Vol. 28, Nr. 4, 1969,
pp. 771-790

Country of Origin: Rumania
Translated by: LINGUISTIC SYSTEMS, INC.
F33657-76-D-0389
Patrick T. Nolan

Requester: FTD/TQTA
Approved for public release;
distribution unlimited.

ACCESSION for	
NTIS	White Section <input checked="" type="checkbox"/>
DOC	Buff Section <input type="checkbox"/>
UNANNOUNCED	<input type="checkbox"/>
JUSTIFICATION	
BY	
DISTRIBUTION/AVAILABILITY CODES	
Dist	Avail. and/or SPECIAL
A	F

<p>THIS TRANSLATION IS A RENDITION OF THE ORIGINAL FOREIGN TEXT WITHOUT ANY ANALYTICAL OR EDITORIAL COMMENT. STATEMENTS OR THEORIES ADVOCATED OR IMPLIED ARE THOSE OF THE SOURCE AND DO NOT NECESSARILY REFLECT THE POSITION OR OPINION OF THE FOREIGN TECHNOLOGY DIVISION.</p>	<p>PREPARED BY: TRANSLATION DIVISION FOREIGN TECHNOLOGY DIVISION WP. AFB, OHIO.</p>
--	---

STUDIES

ON THE SEPARATION OF FLOW AT THE EDGES OF ANTISYMMETRICAL DELTA WINGS IN SUPERSONIC SYSTEM

by Elie Carafoli and Stefan Staicu

Institute of the mechanics of fluids

at the Academy of the Socialist Republic of Romania

In this work we will study the supersonic flow around antisymmetrical delta wings, taking into consideration the separation of flow at the subsonic leading edges. As with the thin delta wing with constant incidence, in this case the flow separates around the edges creating a vortex layer which is situated on the upper side of the wing transforming itself into two concentrated ^(vortex) nucleuses of the same intensity and sign, having however *an* antisymmetrical position. ^(on) the axis of symmetry of the wing. The formation of vortexes directly effect the production of a ^(complex) field of vertical velocity, which will modify the flow in such a way that the pressures will be finite at the leading edges. The distribution of vertical velocities leads to a system of three imaginary wings, through the superpositioning of which a resulting

imaginary wing is obtained, equivalent from an aerodynamic point of view with the real wing. The flow which occurs is homogenous from the second order, and we have the possibility of determining the pressures on the upper and lower sides of the wing and the aerodynamic characteristics.

1. Preliminary Considerations

In the present work we will study the supersonic flow around antisymmetrical thin delta wings, taking into consideration the falling off of flow around the subsonic leading edges. The antisymmetrical distribution of the incidences or of the vertical velocities corresponds to a torsioned delta wing antisymmetrical according to a linear function. The velocity of the undisturbed flow to be U_{∞} , parallel with the axis of symmetry of the wing (Fig. 1).

As with the thin delta wing plane with constant incidence (1), the flow separates at the leading edge, creating a vortex layer situated above as well as below the wing, producing an antisymmetrical movement. The vortex layer having sufficiently small thickness can be considered like a vortex sheet, which winds itself, as various authors have shown, among whom we will mention M. Roy (4), in the form of a horn composed of a concentrated nucleus and a marginal vortex sheet starting from

the leading edge.

Since the incidence is variable on the surface of the wing, the axis on which the horn winds will be a curve and the vortex generation intensity of the nucleus is variable along the axis, proportional with the span of the wing. For simplification, in the following, the axis on which the nucleus of the vortex is situated is considered to be a straight line.

In this manner the field of flow is modified by the existence of two ^{nucleuses} of vortexes of the same intensity and sign, situated antisymmetrically in reference with the axis of symmetry Ox_1 (Fig. 1) at the abscissa c and the ordinate t .

Making these considerations, the flow around the wing remains in continuation conical of the second order and can be treated using methods from the theory of conical motion of the higher order (2). Thus, for the solution of this problem, we will follow the way used in previous papers (1), (3), (11), where solutions were given for the thin delta wings, with constant and antisymmetrical incidence, respectively, (forced antisymmetry) in reference to Ox_1 , which led us to a conical motion as a matter of fact.

For this, we will allow that the effect of the falling off of flow at the leading edges and the formation of the two antisymmetrical nuclei is to create a vertical and longitudinal field of velocity which will bring about modifications on the field of flow, having as a result the avoidance of infinite velocities at the leading edges, as results from classical linear theory. But it can be allowed that the effect of the longitudinal velocities of disturbance will be able to be substituted through that of a distribution corresponding to the vertical velocities. For this, we will consider a distribution of vertical velocity, incidence and antisymmetry respectively, so as to correspond to a real case of an imaginary thin delta wing with variable incidence, different on its two sides, having at the same time finite velocities at the leading edges. Due to antisymmetry, the additional axis and vertical velocities created by the nucleus of the vortices expire toward the middle of wings, becoming equal with zero on the axis of symmetry Ox_1 . In this way the effects of the vortices on the central line are canceled, where later a nought vertical velocity will remain. We will allow that the real thin wing, which has in a certain way finite velocities at the edges through the effect of the falling off of flow, is equivalent from an aerodynamic point of view with an imaginary thin wing, having the same variation of incidences which we defined above.

In order to study the motion easily, through the conical motion method, we will split the imaginary wing corresponding to the distribution of vertical velocity above into three wing components, as we have proceeded in previous cases (1), (3):

1) The thin wing having the variation of antisymmetrical incidence suitably chosen to respect somewhat the phenomena of pressure modifications and vertical velocities on the surface of the wing near the leading edge. In this way we obtain an imaginary thin wing with finite velocity at the leading edges, of equal and opposed sign on the two faces, higher and lower.

2) The wing of symmetrical "thickness" - the notion of "thickness" here has an imaginary sense - having the slope equal and of the same sign as the incidence of the first wing. This wing combined with 1) will have different pressures on the two faces, as happens in reality.

3) The third wing will have symmetrical "thickness" with variable and antisymmetrical slope, however such that, combined with wing 2), to obtain a mean nought slope, corresponds to a real thin wing. Through superpositioning the three wing components, we will obtain the resulting imaginary wing equivalent from an aerodynamic point of view with the delta wing with the separation of flow.

Examining the real phenomena of the falling off of flow at the edges taking into consideration experimental indications, we will manage to chose a distribution corresponding to the vertical velocities or the incidences.

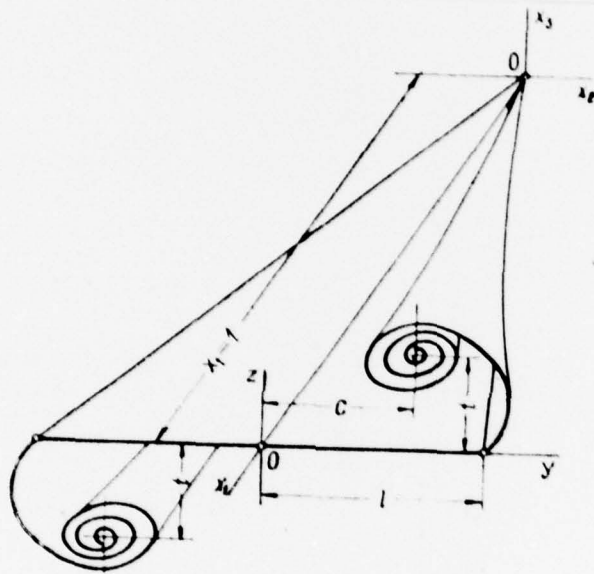

Fig. 1

In this way we will further mark

$$w'_u = -\alpha'_u U_\infty, w'_l = -\alpha'_l U_\infty, \quad (1)$$

the vertical velocities and the incidences, w'_u, α'_u , on the higher side respectively, w'_l, α'_l on the lower of the imaginary thin wing; vertical velocity $w = -\alpha U_\infty$ on the real wing is given by the relation

$$w = w_{01} x_2 = x_1 w_{01} y = -x_1 \alpha_{01} U_\infty y. \quad (2)$$

2. THE DETERMINATION OF THE AXIS OF DISTURBANCE VELOCITIES

In continuation we will determine for the three antisymmetrical wing components, the axis of disturbance velocities, being necessary for the calculation of the distribution of pressures and of the aerodynamic characteristics of the resulting imaginary wings, which are presupposed to be the same as real thin delta wings, having the incidence defined by (2). The motion around the wings being conical of the second order, we will again use the methods used before, considering in this sense the physical plane Oyz (fig. 1) normal on Ox_1 and having the coordinates

$$y = \frac{x_2}{x_1}, z = \frac{x_3}{x_1}, \quad (3)$$

the axes Oy and Oz being parallel, respectively with Ox_2 and Ox_3 . Again we will make the transformation similar with that given by Busemann (fig. 2):

$$\vartheta = \frac{y}{1 - B^2 z^2}, \delta = \frac{z\sqrt{1 - B^2(y^2 + z^2)}}{1 - B^2 z^2}, (x = \vartheta + i\delta), \quad (4)$$

obtaining a plane that has the property of keeping the track of the wing ($\vartheta = y, z = \delta = 0$) in the true magnitude.

As we know, in this plan the first derivatives of the velocities of disturbance u, v, w are harmonic functions and

the respective conjugated functions can be associated in such a manner that analytic functions of complex variables $x = y + iz$ (4) are obtained.

1) the thin antisymmetrical wing. We will consider the vertical velocity on this wing, as a result of the effect of the two vortex nuclei, constant along axis Ox_1 and variable on the track of the wing according to the relation

$$w' = w'_{01}(y)x_2 = x_1 y w'_{01}(y), \quad (5)$$

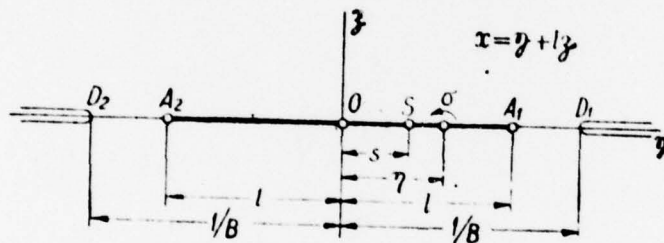

Fig. 2

in which the parameter $w'_{01}(y)$, variable on the wing, is obtained with the help of a distribution corresponding by singularity of the second order (source) placed on the track of the wing from the plane $x = y + iz$, with the intensity q' given by the function

$$q'(y) = q^* \left(1 - \frac{y}{l} \right) \quad (s < y < l), \quad (6)$$

we obtain in this way the velocities $w_{01}^{(1)} x_2 = -\alpha_{01}^{(1)} U_{\infty} x_1 l$, at the edge of wing $w_{01}^{(0)} x_2 = -\alpha_{01}^{(0)} U_{\infty} x_1 y$ for the points on the wing contained between $y = 0$ and $y = s$.

In this manner, in the case of nonhomogeneous motion by order two ($n = 2$), we will have the following distributions of the intensities of sources:

$$q'_{20} = \pm q_{20} \left(1 - \frac{\eta}{l} \right), \quad q'_{21} = \pm q_{21} \left(1 - \frac{\eta}{l} \right) \quad (s \leq \eta \leq l), \quad (7)$$

where η will represent the position of an element of intensity on the track of the wing from the auxiliary plane $x = \eta + i\gamma$. Keeping in mind previous works (2), the contribution of elementary sources dq' in the expression of the axis of disturbance velocity from point x will be

$$dU = (dq'_{20} + x dq'_{21}) \cosh^{-1} \sqrt{\frac{(l+\eta)(l-x)}{2l(\eta-x)}}. \quad (8)$$

The axis of disturbance velocity for the thin wing component will be obtained through the addition of all the contributions of sources under the form

$$\begin{aligned} \frac{1}{x} U_x = U_{1x} = & \frac{A_{21} x}{\sqrt{l^2 - x^2}} + \frac{2}{\pi} \int_s^l \left(1 - \frac{\eta}{l} \right) (q_{20} + x q_{21}) \cosh^{-1} \sqrt{\frac{(l+\eta)(l+x)}{2l(\eta-x)}} d\eta - \\ & - \frac{2}{\pi} \int_s^l \left(1 - \frac{\eta}{l} \right) (q_{20} - x q_{21}) \cosh^{-1} \sqrt{\frac{(l+\eta)(l+x)}{2l(\eta+x)}} d\eta, \quad (9) \end{aligned}$$

which, after completing the calculations, becomes

$$\begin{aligned} \frac{1}{x} U_x = U_{1x} = & \frac{A_{21} x}{\sqrt{l^2 - x^2}} - \frac{1}{\pi} \left[(q_{20} + q_{21} x)(s-x) \left(1 - \frac{s+x}{2l} \right) \cosh^{-1} \frac{l^2 - sx}{l(s-x)} - \right. \\ & - (q_{20} - q_{21} x)(s+x) \left(1 - \frac{s-x}{2l} \right) \cosh^{-1} \frac{l^2 + sx}{l(s+x)} + \\ & \left. + x \left((q_{20} - 2q_{21} l) \cos^{-1} \frac{s}{l} + q_{21} l \sqrt{1 - \frac{s^2}{l^2}} \right) \sqrt{1 - \frac{x^2}{l^2}} \right]. \quad (10) \end{aligned}$$

2) The wing of symmetrical thickness, with the slope equal with the incidence of the first thin wing. The introduction of the second wing, of symmetrical "thickness", is necessary in order to remove accentuated peaks of pressure on the lower side of the wing, where the division of the pressures obtained through superpositioning with the first wing component, will be different from that on the higher side of the wing. Following the general method of conical motions (2), for a wing of symmetrical thickness with the variation of slope given by the same distribution of sources (7), we will write for the axis of disturbance velocity the following expression, similar with (9):

$$\frac{1}{x_1} u_x = u_y = \frac{2}{\pi} \int_0^l \left(1 - \frac{\eta}{l}\right) (q_{20}^* + x q_{21}^*) \cos h^{-1} \sqrt{\frac{(1 + B\eta)(1 - Bx)}{2B(\eta - x)}} d\eta -$$

$$- \frac{2}{\pi} \int_0^l \left(1 - \frac{\eta}{l}\right) (q_{20}^* - x q_{21}^*) \cos h^{-1} \sqrt{\frac{(1 + B\eta)(1 + Bx)}{2B(\eta + x)}} d\eta \pm L. \quad (11)$$

Completing the above integrals, we find

$$\frac{1}{x_1} u_x = u_y = \frac{1}{\pi} \left\{ (q_{20}^* + q_{21}^* x) \left[(l - x) \left(1 - \frac{l+x}{2l}\right) \cos h^{-1} \frac{1 - B^2 l x}{B(l-x)} - \right. \right.$$

$$\left. - (s - x) \left(1 - \frac{s+x}{2l}\right) \cos h^{-1} \frac{1 - B^2 s x}{B(s-x)} \right] -$$

$$\left. - (q_{20}^* - q_{21}^* x) \left[(l + x) \left(1 - \frac{l-x}{2l}\right) \cos h^{-1} \frac{1 + B^2 l x}{B(l+x)} - \right. \right.$$

$$\begin{aligned}
& - (s+x) \left(1 - \frac{s-x}{2l} \right) \cosh^{-1} \frac{1+B^2sx}{B(s+x)} - \\
& - \frac{x\sqrt{1-B^2x^2}}{Bl} \left[(\sin^{-1} Bl - \sin^{-1} Bs) (q_{20}^* - 2q_{21}^*) - \right. \\
& \left. - \frac{q_{21}^*}{B} (\sqrt{1-B^2l^2} - \sqrt{1-B^2s^2}) \right] \pm L, \tag{12}
\end{aligned}$$

where L represents the contribution of the subsonic edge having the slope equal with $\alpha_{01}^{(1)}$.

3) The wing of symmetrical thickness compensating for slope. In continuation we will remark that through the introduction of the effect of the wing from point 2), the resulting wing became the "large" wing. We will be able to compensate this work, introducing on the track of the wing from plane x (4) a new distribution of source of an adequate form, which will restore the wing to an average nought thickness. The variation of the vertical velocities w_z^* , given by these sources, which will necessarily present at the edge of the wing the velocity $-w_{01}x_1^l$, will correspond with a "wing compensating for slope" of symmetrical "thickness", which has the role of canceling the mean slope and the effect of the edge of the wing from 2). The distribution of sources q_z^* , which we will introduce, will be necessary to create on the lower side of the wing a distribution of pressures without accentuated peaks, approximately linear, with the exception of the region near the leading edge.

For this, for simplification, we will chose the following expressions of the contribution of sources:

$$q_{10}'' = \pm k_{20}\eta(1 + k_{10}\eta), q_{21}'' = \pm k_{21}\eta(1 + k_{11}\eta) \quad (0 \leq \eta \leq l), \quad (13)$$

considered equal and of opposed sign for the symmetrical points on axis Ox_1 of the wing.

We obtain, in this manner, two "large wings" to form a single one, having the slope variable in such a way that the mean will be nought. For this wing, the expression of the axis of disturbance velocity U_{10} will be, similar with (11), the following:

$$\begin{aligned} \frac{1}{x_1} u_c = u_{1c} = & \frac{2}{\pi} k_{20} \int_0^l \eta (1 + k_{10} \eta) \left(\cosh^{-1} \sqrt{\frac{(1 + B\eta)(1 - Bx)}{2B(\eta - x)}} \right. \\ & \left. - \cosh^{-1} \sqrt{\frac{(1 + B\eta)(1 + Bx)}{2B(\eta + x)}} \right) d\eta + \\ & + x \frac{2}{\pi} k_{21} \int_0^l \eta (1 + k_{11} \eta) \left(\cosh^{-1} \sqrt{\frac{(1 + B\eta)(1 - Bx)}{2B(\eta - x)}} + \right. \\ & \left. + \cosh^{-1} \sqrt{\frac{(1 + B\eta)(1 + Bx)}{2B(\eta + x)}} \right) d\eta \pm L, \end{aligned} \quad (14)$$

which can be put under the form, after integrating,

$$\begin{aligned} \frac{1}{x_1} u_c = u_{1c} = & \frac{k_{20}}{2\pi B^2} \left[B^2(l^2 - x^2) \left(\cosh^{-1} \frac{1 - B^2 l x}{B(l - x)} - \cosh^{-1} \frac{1 + B^2 l x}{B(l + x)} \right) + \right. \\ & \left. + 2 \sin^{-1} B l B x \sqrt{1 - B^2 x^2} \right] + \frac{k_{20} k_{10}}{3\pi B^3} \left[B^3(l^3 - x^3) \cosh^{-1} \frac{1 - B^2 l x}{B(l - x)} - \right. \\ & \left. - B^3(l^3 + x^3) \cosh^{-1} \frac{1 + B^2 l x}{B(l + x)} + 2B^2 x^2 \cosh^{-1} \frac{1}{Bx} + \right. \end{aligned}$$

$$\begin{aligned}
& + 2(1 - \sqrt{1 - B^2 l^2}) Bx \sqrt{1 - B^2 x^2} \Big] + \\
& + x \left\{ \frac{k_{21}}{2\pi B^2} \left[B^2(l^2 - x^2) \left(\cos h^{-1} \frac{1 - B^2 l x}{B(l - x)} + \cos h^{-1} \frac{1 + B^2 l x}{B(l + x)} \right) + \right. \right. \\
& + 2B^2 x^2 \cos h^{-1} \frac{1}{Bx} + 2(1 - \sqrt{1 - B^2 l^2}) \sqrt{1 - B^2 x^2} \Big] + \\
& + \frac{k_{21} k_{11}}{3\pi B^2} \left[B^2(l^2 - x^2) \cos h^{-1} \frac{1 - B^2 l x}{B(l - x)} + B^2(l^2 + x^2) \cos h^{-1} \frac{1 + B^2 l x}{B(l + x)} \right. \\
& \left. \left. + (2 \sin^{-1} Bl B^2 x^2 + \sin^{-1} Bl - Bl \sqrt{1 - B^2 l^2}) \sqrt{1 - B^2 x^2} \right] \right\} \pm L. \quad (15)
\end{aligned}$$

Superpositioning the three wing components, the resulting imaginary wing is obtained, equivalent from an aerodynamical point of view with the real wing for which the axis of disturbance velocity has the expression

$$U_1 = U_{11} + U_{12} + U_{13} \quad (16)$$

which will be antisymmetrical on the axis of symmetry Ox_1 and continue in the origin O . We observe that the velocity U_{11} on the higher side is equal and of opposed sign with that on the lower side, as corresponds to thin wings.

3. THE DETERMINATION OF THE CONSTANTS

For the determination of the constants q_{20}^* and q_{21}^* which appear in expression (10) of U_{11} , we will start from the following conditions

$$\operatorname{Im} \left(\int_0^1 \sqrt{1 - B^2 x^2} \frac{d^2}{dx^2} \left(\frac{d\mathcal{U}_1}{d\eta} \right) dx \right) = 0, \quad (17a)$$

$$- \operatorname{Im} \left(\int_0^1 \frac{\sqrt{1 - B^2 x^2}}{x} \frac{d^2}{dx^2} \left(\frac{d\mathcal{U}_1}{d\eta} \right) dx \right) = \frac{dw'_{01}}{d\eta}, \quad (17b)$$

deduced from the theory of conical motion(2), the integration being accomplished on a semicircle σ of very small radius around a certain point $y = \eta$ on the wing, contained in the interval ($y = s, y = 1$), (fig. 2).

We will obtain, in this way the relations

$$q'_{20} = \frac{dw'_{01}}{d\eta} \frac{\eta^2}{(1 - B^2 \eta^2)^{3/2}}, \quad q'_{21} = - \frac{dw'_{01}}{d\eta} \frac{B^2 \eta^3}{(1 - B^2 \eta^2)^{3/2}}, \quad (18)$$

which stabilize the dependence from among the variation of the sources and the distribution of vertical velocities.

Taking into consideration (7), we will start from (18) and we will put the conditions at the limit in the points $\eta = s$ and $\eta = 1$ for the vertical velocity $w'_{01} x_2$:

$$w_{01}^{(1)} - w_{01}^{(0)} = \frac{q'_{20}}{l} \int_s^1 \frac{(1 - \eta)(1 - B^2 \eta^2)}{\eta^2} \sqrt{1 - B^2 \eta^2} d\eta, \quad (19a)$$

$$w_{01}^{(1)} - w_{01}^{(0)} = - \frac{q'_{21}}{B^2 l} \int_s^1 \frac{(1 - \eta)(1 - B^2 \eta^2)}{\eta^3} \sqrt{1 - B^2 \eta^2} d\eta, \quad (19b)$$

from where we deduce the first relations from among the constants $q'_{20}, q'_{21}, w_{01}^{(0)}$ and $w_{01}^{(1)}$:

$$\begin{aligned}
& -\frac{q_{20}}{l} \left\{ \left(1 + \frac{l}{s}\right) \sqrt{1 - B^2 s^2} - 2 \sqrt{1 - B^2 l^2} - \frac{3}{2} Bl(\sin^{-1} Bl - \sin^{-1} Bs) - \right. \\
& \quad \left. - \frac{1}{2} B^2 l^2 \left(\sqrt{1 - B^2 l^2} - \frac{s}{l} \sqrt{1 - B^2 s^2} \right) - \right. \\
& \quad \left. - \frac{1}{3} \left[(1 - B^2 l^2)^{3/2} - (1 - B^2 s^2)^{3/2} \right] + \cos h^{-1} \frac{1}{Bl} - \cos h^{-1} \frac{1}{Bs} \right\} = w_{01}^{(0)} - w_{01}^{(1)}, \quad (20a)
\end{aligned}$$

$$\begin{aligned}
& \frac{q_{21}}{2B^2 l^2} \left\{ (1 - B^2 l^2)^{3/2} + \left[B^2 l^2 \left(2 - \frac{s}{l} \right) + \frac{l^2}{s^2} \left(1 - 2 \frac{s}{l} \right) \right] \sqrt{1 - B^2 s^2} + \right. \\
& \quad \left. + 3B^2 l^2 \left(\cos h^{-1} \frac{1}{Bl} - \cos h^{-1} \frac{1}{Bs} \right) + \right. \\
& \quad \left. + 3Bl(\sin^{-1} Bl - \sin^{-1} Bs) \right\} = w_{01}^{(0)} - w_{01}^{(1)}. \quad (20b)
\end{aligned}$$

On the other part, the mean vertical velocity $w_{01} x_2$ or the mean incidence $w_{01} x_2$ of the real wing, equal with that of the first wing components as with that of the resulting imaginary wings, is obtained keeping in mind that the two large wings 2) and 3) are compensated reciprocally creating a nought mean slope; we will be able to write the relation

$$\frac{2}{l} \int_0^l w_{01} \eta d\eta = w_{01} l, \quad (21)$$

corresponding only to the thin wing components 1). Proceeding in this way and taking into consideration (21) we will have

$$\frac{1}{2} w_{01} l^2 = \frac{1}{2} w_{01}^{(0)} s^2 + \int_0^l w_{01} \eta d\eta, \quad (22)$$

which, after accomplishing the calculations, becomes

$$\begin{aligned}
& \frac{q_{20}}{8B^2 l^2} \left\{ 3 [\sin^{-1} Bl - \sin^{-1} Bs + Bl(1 - B^2 l^2)^{1/2} - Bs(1 - B^2 s^2)^{1/2}] + \right. \\
& \quad \left. + 2 [Bl(1 - B^2 l^2)^{3/2} - Bs(1 - B^2 s^2)^{3/2}] + \right. \\
& \quad \left. + \frac{8}{5Bl} \left[(1 - B^2 l^2)^{5/2} - (1 - B^2 s^2)^{5/2} \right] \right\} = w_{01}^{(1)} - w_{01}. \quad (23)
\end{aligned}$$

We will determine the constant A_{21} , which appears in the expression (9) of the axis of disturbance velocity, considering the variation of vertical velocities w'_{01} from a point on the wing to the one of the nought vertical velocity (for example on the Mach cone). In order to avoid the difficult calculations which appear, we will consider that the sources distributed on the line in the interval (s, l) are concentrated in $y = s'$ of intensities Q_{20} and Q_{21} in such a way that we will have

$$s' = s + \frac{l-s}{3}, Q_{20} = \frac{1}{2} q_{20}^* l \left(1 - \frac{s}{l}\right)^2, Q_{21} = \frac{1}{2} q_{21}^* l \left(1 - \frac{s}{l}\right)^2. \quad (24)$$

Proceeding in this way, we will write the relation

$$\operatorname{Re} i \int_{\text{aripk}}^{\text{cercul Mach}} \frac{\sqrt{1 - B^2 x^2}}{x} \frac{d^2(\mathcal{U}'_1)}{dx^2} dx = w_{01}^{(1)}, \quad (25)$$

where \mathcal{U}'_{11} is the axis of disturbance velocity for the simplified case of the source concentrated in $y = s'$, given by the expression

$$\begin{aligned} \mathcal{U}'_{11} = \frac{1}{x_1} \mathcal{U}'_1 = & \frac{A_{21} x}{\sqrt{l^2 - x^2}} + \frac{2}{\pi} (Q_{20} + Q_{21} x) \cos h^{-1} \sqrt{\frac{(l+s')(l-x)}{2l(s'-x)}} - \\ & - \frac{2}{\pi} (Q_{20} - Q_{21} x) \cos h^{-1} \sqrt{\frac{(l+s')(l+x)}{2l(s'+x)}}. \end{aligned} \quad (26)$$

Accomplishing the integral (25) on the axis of the ordinates ($y = 0, x = l$) between the limits 0 and ∞ , results

$$\begin{aligned} & A_{21} \frac{(2 - B^2 l^2) E(k) - B^2 l^2 K(k)}{l^2 (1 - B^2 l^2)} + \\ & + \frac{9}{4\pi} q_{20}^* \left(1 - \frac{s'}{l}\right)^2 \frac{\sqrt{l^2 - s'^2}}{s'l(1 - B^2 s'^2)} \left[(1 - B^2 s'^2) E(k) - \right. \end{aligned}$$

$$+ \frac{9}{4\pi} l q_{21}^* \left(1 - \frac{s'}{l}\right)^2 \frac{B^2 \sqrt{l^2 - s'^2}}{1 - B^2 s'^2} [(2 - B^2 s'^2) \Pi(\rho, k) - K(k)] = -w_{01}^*, \quad (27)$$

in which $K(k)$, $E(k)$, $\Pi(\rho, k)$ represent the complete elliptical integrals of the first, second and third instances respectively, having the module k and the parameter ρ given by the relations

$$\Pi(\rho, k) = K(k) + \frac{\sqrt{1 - B^2 s'^2}}{B^2 s' \sqrt{l^2 - s'^2}} \left[\frac{\pi}{2} - K(k) E(\varphi_0, k') + (K(k) - E(k)) F(\varphi_0, k') \right], \quad (28a)$$

$$k = \sqrt{1 - B^2 l^2}, \quad \rho = B^2 s'^2 - 1 = \frac{1}{9} B^2 (l + 2s)^2 - 1, \\ k' = Bl, \quad \varphi_0 = \sin^{-1} \frac{s'}{l}. \quad (28b)$$

Furthermore, due to the separation of flow at the edges, we will impose the condition that the velocity be finite at the subsonic edges, canceling the constant A_{21} :

$$A_{21} = 0. \quad (29)$$

Eliminating $w_0^{(0)}$ and $w_0^{(1)}$ between the equations (20a), (20b), (23) and (27), we will obtain the constants q_{20}^* and q_{21}^* ,

$$q_{20}^* = - \frac{I_{21}}{I_{21} J_{20} - I_{20} J_{21}} w_{01}^*, \quad q_{21}^* = \frac{I_{20}}{I_{21} J_{20} - I_{20} J_{21}} w_{01}^*, \quad (30)$$

In which we made the notations

$$I_{20} = 2B^2 l \left\{ \left(1 + \frac{l}{s}\right) \sqrt{1 - B^2 s^2} - 2 \sqrt{1 - B^2 l^2} - \frac{3}{2} Bl (\sin^{-1} Bl - \sin^{-1} Bs) - \frac{1}{2} B^2 l^2 (\sqrt{1 - B^2 l^2} - \frac{s}{l} \sqrt{1 - B^2 s^2}) - \frac{1}{3} [(1 - B^2 l^2)^{3/2} - (1 - B^2 s^2)^{3/2}] + \cosh^{-1} \frac{1}{Bl} - \cosh^{-1} \frac{1}{Bs} \right\}, \quad (31a)$$

$$I_{21} = (1 - B^2 l^2)^{3/2} + \left[B^2 l^2 \left(2 - \frac{s}{l} \right) + \frac{l^2}{s^2} \left(1 - 2 \frac{s}{l} \right) \right] \sqrt{1 - B^2 s^2} +$$

$$+ 3Bl \left[\sin^{-1} Bl - \sin^{-1} Bs + Bl \left(\cos h^{-1} \frac{1}{Bl} - \cos h^{-1} \frac{1}{Bs} \right) \right]. \quad (31 b)$$

$$J_{21} = \frac{1}{8Bl^2} \left\{ 3 \left[\sin^{-1} Bl - \sin^{-1} Bs + Bl (1 - B^2 l^2)^{1/2} - Bs (1 - B^2 s^2)^{1/2} \right] + \right.$$

$$+ 2 \left[Bl (1 - B^2 l^2)^{3/2} - Bs (1 - B^2 s^2)^{3/2} \right] +$$

$$+ \frac{8}{5Bl} \left[(1 - B^2 l^2)^{5/2} - (1 - B^2 s^2)^{5/2} \right] \left. + \right.$$

$$+ \frac{9}{4\pi s'} \left(1 - \frac{s'}{l} \right)^2 \frac{\sqrt{1 - \frac{s'^2}{l^2}}}{1 - B^2 s'^2} \left[(1 - B^2 s'^2) E(k) - B^2 l^2 (K(k) - \Pi(\rho, k)) \right].$$

(31 c)

$$J_{22} = \frac{1}{2B^2 l^2} \left\{ (1 - B^2 l^2)^{3/2} + \left[B^2 l^2 \left(2 - \frac{s}{l} \right) + \frac{l^2}{s^2} \left(1 - 2 \frac{s}{l} \right) \right] \sqrt{1 - B^2 s^2} \right.$$

$$+ 3B^2 l^2 \left(\cos h^{-1} \frac{1}{Bl} - \cos h^{-1} \frac{1}{Bs} \right) +$$

$$+ 3Bl (\sin^{-1} Bl - \sin^{-1} Bs) \left. + \right.$$

$$+ \frac{9}{4\pi} \left(1 - \frac{s'}{l} \right)^2 \frac{B^2 l^2 \sqrt{1 - \frac{s'^2}{l^2}}}{1 - B^2 s'^2} [(2 - B^2 s'^2) \Pi(\rho, k) - K(k)]. \quad (31 d)$$

The constants k_{10} , k_{20} , k_{11} and k_{21} , which appear in the expression of U_{1c} given by (14), is determined taking into consideration the role of the third wing component which will have mean slope $-w_{01}x_2$; similar with (21) we will write

$$-\frac{1}{2} w_{01} l^2 = \int_0^l w_{01}' \eta d\eta, \quad (32)$$

from where we deduce the relations

$$(w_{01} - w_{01}^{(1)}) l^2 = k_{20} \int_0^l \eta (1 + k_{10} \eta) (1 - B^2 \eta^2)^{3/2} d\eta, \quad (33a)$$

$$(w_{01} - w_{01}^{(1)}) l^2 = -\frac{k_{21}}{B^2} \int_0^l (1 + k_{11} \eta) (1 - B^2 \eta^2)^{3/2} d\eta, \quad (33b)$$

which ends the form

$$w_{01}^{(1)} - w_{01} = \frac{k_{20}}{B^2 l^2} \left\{ \frac{1}{5} ((1 - B^2 l^2)^{5/2} - 1) + \frac{1}{2} k_{10} l \left[\frac{1}{3} (1 - B^2 l^2)^{3/2} - \frac{1}{12} (1 - B^2 l^2)^{3/2} - \frac{1}{8} \left(\sqrt{1 - B^2 l^2} + \frac{\sin^{-1} Bl}{Bl} \right) \right] \right\}, \quad (34a)$$

$$w_{01}^{(1)} - w_{01} = \frac{k_{21}}{B^2 l^2} \left\{ \frac{1}{8} Bl \left[2(1 - B^2 l^2)^{3/2} + 3 \left(\sqrt{1 - B^2 l^2} + \frac{\sin^{-1} Bl}{Bl} \right) \right] - \frac{k_{11}}{5B} \left((1 - B^2 l^2)^{5/2} - 1 \right) \right\}. \quad (34b)$$

Considering for k_{10} and k_{11} suitable values

$$k_{10} = k_{11} = -\frac{1}{2l}, \quad (35)$$

we will obtain from equations (23), (34a) and (34b) the constants k_{20} and k_{21} :

$$\begin{aligned} k_{20} &= \frac{1}{2} B q_{20} \left\{ 3 [\sin^{-1} Bl - \sin^{-1} B_0 + Bl(1 - B^2 l^2)^{3/2} - B_0(1 - B_0^2)^{3/2}] + \right. \\ &+ 2 [Bl(1 - B^2 l^2)^{3/2} - B_0(1 - B_0^2)^{3/2}] + \\ &+ \frac{8}{\pi Bl} \left[(1 - B^2 l^2)^{5/2} - (1 - B_0^2)^{5/2} \right] \left. \right\} \times \end{aligned}$$

$$\times \left[\frac{7}{15} (1 - B^2 t^2)^{3/2} + \frac{1}{12} (1 - B^2 t^2)^{5/2} + \frac{1}{8} \left(\sqrt{1 - B^2 t^2} + \frac{\sin^{-1} Bl}{Bl} \right) - \frac{4}{5} \right]^{-1}, \quad (36a)$$

$$\begin{aligned} C_p = & \frac{B^2 l}{4} q_{\infty}^2 \left\{ 3 \left[\sin^{-1} Bl - \sin^{-1} Bs + Bl(1 - B^2 t^2)^{1/2} - Bs(1 - B^2 s^2)^{1/2} \right] + \right. \\ & + 2 \left[Bl(1 - B^2 t^2)^{3/2} - Bs(1 - B^2 s^2)^{3/2} \right] + \\ & + \left. \frac{8}{5Bl} \left[(1 - B^2 t^2)^{5/2} - (1 - B^2 s^2)^{5/2} \right] \right\} \times \\ & \times \left\{ \frac{1}{4} B^2 t^2 \left[2(1 - B^2 t^2)^{3/2} + 3 \left(\sqrt{1 - B^2 t^2} + \frac{\sin^{-1} Bl}{Bl} \right) \right] + \right. \\ & + \left. \frac{1}{5} \left((1 - B^2 t^2)^{5/2} - 1 \right) \right\}^{-1}. \quad (36b) \end{aligned}$$

4. THE DISTRIBUTION OF PRESSURE AND AERODYNAMIC CHARACTERISTICS

We have shown that the axis of disturbance velocity on the real wing results through the superpositioning of the three imaginary wing components, obtaining formula (16). In this way, the coefficient of pressure will be obtained considering the axis velocity given by (16), (fig.3):

$$C_p = -2 \frac{u_1}{U_{\infty}} = -2 \operatorname{Re} \frac{u_1}{U_{\infty}}. \quad (37)$$

For the calculation of the coefficient of lift of the straight line of the wing we will make the observation that the wings of symmetrical thickness do not give lift, so we will only consider that given by "the lift wing":

$$C_i = \frac{s}{3lU_\infty} \int_0^l u_{1i} dy. \quad (38)$$

Accomplishing the calculations, we obtain

Efectuind calculele, se va obtine

$$C_i = \frac{8l}{3\pi U_\infty} \left\{ q_{20}^* \left[\left(1 - \frac{1}{3} \frac{s}{l} \right) \sqrt{1 - \frac{s^2}{l^2}} - \frac{1}{3} \cos^{-1} \frac{s}{l} - \frac{s^2}{l^2} \left(1 - \frac{2}{3} \frac{s}{l} \right) \cosh^{-1} \frac{l}{s} \right] + q_{21}^* l \left[\frac{2}{3} \cos^{-1} \frac{s}{l} - \frac{1}{2} \sqrt{1 - \frac{s^2}{l^2}} - \frac{s}{l} \left(\frac{1}{3} - \frac{1}{4} \frac{s}{l} \right) \left(\sqrt{1 - \frac{s^2}{l^2}} + \frac{s^2}{l^2} \cosh^{-1} \frac{l}{s} \right) \right] \right\}. \quad (39)$$

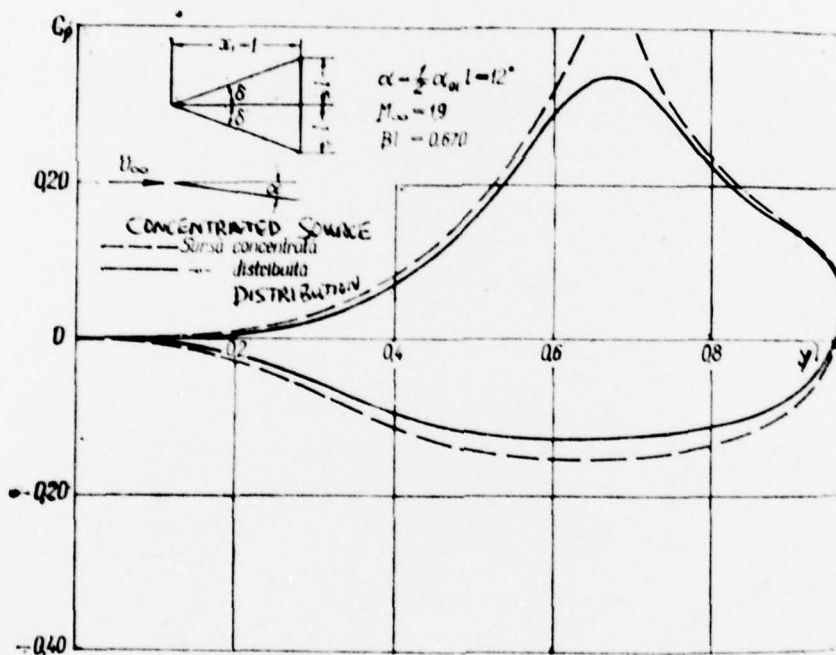

Fig. 3

The coefficient of the moment of roll is

$$HC_m = \frac{2}{lU_\infty} \int_0^l u_{1i} y dy, \quad (40)$$

which, after accomplishing the calculations, terminates the form

$$H_0 = \frac{l^2}{8U_\infty} \left\{ q_{s0} \left[\left(\frac{8}{3} \left(1 - \frac{s^2}{l^2} \right) - \frac{s}{l} \left(1 - 2 \frac{s^2}{l^2} \right) \right) \sqrt{1 - \frac{s^2}{l^2}} - \cos^{-1} \frac{s}{l} \right] + \right. \\ \left. + q_{d0} l \left[2 \cos^{-1} \frac{s}{l} - \sqrt{1 - \frac{s^2}{l^2}} \left(\frac{8}{5} + \frac{1}{3} \frac{s}{l} \left(1 + 2 \frac{s^2}{l^2} \right) \left(2 - \frac{8}{5} \frac{s}{l} \right) \right) \right] \right\} \quad (41)$$

where H is a reference length (fig. 4).

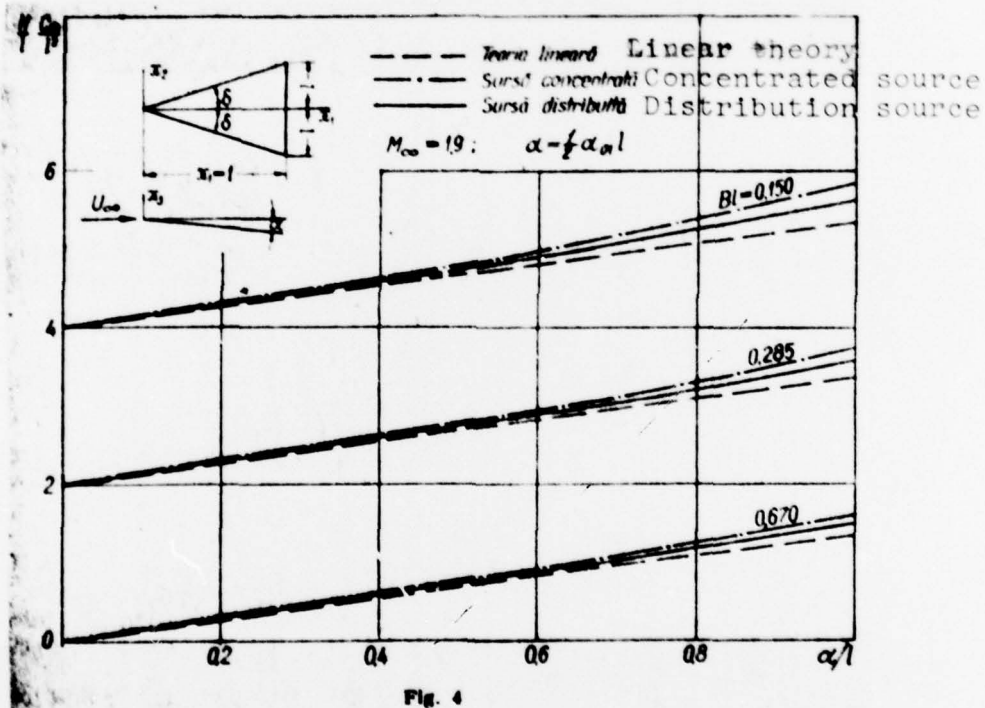

For the definition of the parameter $\frac{s}{l}$, which enters the expressions above and which determines the limits of the distribution of sources, we will remark first that the position of maximum distribution of pressures coincide with the abscissa $y = c$ of the center of the vortex nucleus, as is

ascertained from experience. However, making the calculation on the base of distribution of sources (6), it is ascertained that the peak of the depressions on the higher side of the wing falls approximately at half the distance between the center of gravity of the intensity of the sources and the point of abscissa s , which we follow to determine it. In this way we can deduce the relation between s and c

$$c = s + \frac{1}{6}(l - s) \quad \left(\frac{s}{l} = 1,2 \frac{c}{l} - 0,2 \right). \quad (43)$$

For the definition of the positions of the vortex nuclei, we will observe that at small torsion of the wing, this can be considered approximately plane and parallel with the direction of the undisturbed flow U_∞ , so that the vortexes falling off at the leading edges, in the form of a horn would be considered as attached to the ^{higher} surface of the wing. This work would lead, however small the intensity of the vortexes would be, to very great local velocities, incompatible with the real effects of the separation of flow at the edges. In order to avoid this work we must allow that at very small torsion of the wing, therefore, for very small values of the parameter $\alpha_{01}(2)$ or, more exactly, when $\alpha_{01} \rightarrow 0$, the position of the vortex nucleus will be $c = 1$.

For greater torsion of the wing we will allow that the nature of the vortexes which start on the leading edges, evolve

proportionately with the incidence $\alpha = \alpha_{01} x_2$ as well as with the span of the wing (as with the wing with constant incidence (1)), therefore with the square of the span of the wing, and winds itself on an axis representing the line of the center of gravity, corresponding to the abscissa

$$\frac{c}{l} = \frac{3}{4}. \quad (13)$$

We will remark however that the intensity of the vortex nucleus is something smaller than the total vortex generation intensity, the rest being in the layer which forms the surface of the horn along the leading edge.

From that, orienting ourselves according to the experiences accomplished on the delta wing with constant incidence, the minimum position of the vortex center, corresponding to torsion or greater parameter $w_{01} = -\alpha_{01} U_{\infty}$, can be considered to contain between

$$c \cong 0,6l \div 0,7l, \quad (14)$$

that which would correspond with the center of gravity of only a part of the total intensity of the vortexes, representing just the real intensity of the remaining nucleus (about 80%).

What makes this minimum position to be the weight of stability is the fact that at great incidences ^(interior)vortex nuclei appear, of opposed sign with the principal, situated between

this and the leading edge.

Between these limits, taking into consideration the experimental results obtained by various authors on the plane delta wing with constant incidence we will allow the following approximate formula of variation with the incidence for the position of the vortex nucleus:

$$\frac{c}{l} \cong \frac{1}{1 + 1,1 (\alpha)^{1/2}}, \quad (45)$$

where α represents the incidence of the wing between a suitable point, representing the center of gravity of the aerodynamic effects, namely

$$x_1 = \frac{3}{4}, \quad x_2 = \frac{2}{3}, \quad x_1 l = \frac{1}{2} l. \quad (46)$$

We will remark, that the whole reasoning which has led to the stability formula (45) can apply for each section of the wing, obtaining in this way a curved line for the position of the vortexes nuclei. However the deviations from a straight line is ascertained toward the peak of the wing, where the aerodynamic contributions are very small, and behind the wing, where the incidences grow, the vortexes sit rectilinear. From this, we can allow a straight line for the axis on which the vortex sheet winds in the form of a horn, corresponding to the section given by (46).

This hypotesis permits us to apply the methods of conical flow of the higher order.

5. THE CASE OF CONCENTRATED SOURCES

Considering, for simplification, a sudden variation of vertical velocity in the point $s' = c$, corresponding to the abscissa of the vortex nucleus, we will obtain the case of an "edge" of separation of vertical velocities $w_{01}^{(0)} cx_1$ and $w_{01}^{(d)} cx_1$ (2).

The sudden drop of vertical velocity or of incidence is realized analytically with the help of logarithmic singularities concentrated in the points $s' = \pm c$ on the track of the wing in the auxiliary plane x (4), having the intensities Q_{20} and Q_{21} .

In this case, the axes of disturbance velocities of the three wing components have the following expressions

$$\begin{aligned} u_0 &= \frac{1}{x_1} u_1 = \frac{A_{21} x}{|l^2 - x^2|} + \frac{2}{\pi} (Q_{20} + Q_{21} x) \cosh^{-1} \sqrt{\frac{(l+c)(l-x)}{2l(c-x)}} - \\ &- \frac{2}{\pi} (Q_{20} - Q_{21} x) \cosh^{-1} \sqrt{\frac{(l+c)(l+x)}{2l(c+x)}} = \\ &= \frac{A_{21} x}{|l^2 - x^2|} + \frac{2}{\pi} \left(\pm Q_{20} \cosh^{-1} \frac{x}{l} \sqrt{\frac{l^2 - x^2}{c^2 - x^2}} + Q_{21} x \cosh^{-1} \sqrt{\frac{l^2 - x^2}{c^2 - x^2}} \right) \end{aligned} \quad (47)$$

for the "thin lift wing";

$$\begin{aligned} u_0 &= \frac{1}{x_1} u_1 = \frac{2}{\pi} (Q_{20} + Q_{21} x) \cosh^{-1} \sqrt{\frac{(1+Be)(1-Bx)}{2B(c-x)}} - \\ &- \frac{2}{\pi} (Q_{20} - Q_{21} x) \cosh^{-1} \sqrt{\frac{(1+Be)(1+Bx)}{2B(c+x)}} = \\ &= \frac{2}{\pi} \left(\pm Q_{20} \cosh^{-1} Be \sqrt{\frac{1-B^2 x^2}{B^2(c^2-x^2)}} + Q_{21} x \cosh^{-1} \sqrt{\frac{1-B^2 x^2}{B^2(c^2-x^2)}} \right) \pm l \end{aligned} \quad (48)$$

for the "large wing", and

$$u'_i = u_i \quad (49)$$

for the "compensating wing" for slope, where u_i has the expression given by (15). Given that we will remark that the sign of the axis velocity u'_i is different on the two sides of the wing. The expression of the total axis velocity will be given by a formula similar with (16), which will permit us to determine the distribution of pressures.

Starting from (17a) and (17b), we will find in the case of concentrated sources for Q_{20} and Q_{21} , the following expressions:

$$Q_{20} = \frac{c^2}{(1 - B^2 c^2)^{3/2}} (w_{01}^{(1)} - w_{01}^{(0)}), \quad Q_{21} = - \frac{B^2 c^3}{(1 - B^2 c^2)^{3/2}} (w_{01}^{(1)} - w_{01}^{(0)}). \quad (50)$$

and from (25), in which we introduced u'_i given by (47), we will obtain

$$\begin{aligned} A_{21} & \frac{(2 - B^2 l^2) E(k) - B^2 l^2 K(k)}{c^2 (1 - B^2 l^2)} + \\ & + \frac{2}{\pi} Q_{20} \frac{\sqrt{c^2 - c'^2}}{c l^2 (1 - B^2 c^2)} [(1 - B^2 c^2) E(k) - B^2 l^2 (K(k) - \Pi(\rho, k))] + \\ & + \frac{2}{\pi} Q_{21} \frac{B^2 \sqrt{l^2 - c^2}}{1 - B^2 c^2} [(2 - B^2 c^2) \Pi(\rho, k) - K(k)] = - w_{01}^{(0)}. \quad (51) \end{aligned}$$

in which the complete elliptical integrals, in this formula, have the module and the parameter ρ given by the relations (28a) and (28b), in which will be put $s' = c$.

Using the relation (21), we will obtain

$$(w_{01}^{(0)} - w_{01}^{(1)}) c^2 = (w_{01} - w_{01}^{(1)}) l^2, \quad (52)$$

which, together with the condition that the velocity be finite at the edges

$$A_{21} = 0, \quad (53)$$

and with the equations (50), and (51) form the system of equations from which we deduce the constants.

In this manner, we will obtain respectively

$$\frac{w_{01}^{(1)}}{w_{01}} = \frac{E(k) - B^2 l^2 [K(k) - (1 - B^2 c^2) \Pi(\rho, k)]}{E(k) - B^2 l^2 [K(k) - (1 - B^2 c^2) \Pi(\rho, k)] - \frac{\pi}{2} (1 - B^2 c^2) \sqrt{\left(\frac{l^2}{c^2} - 1\right) (1 - B^2 c^2)}}, \quad (54a)$$

$$\frac{w_{01}^{(2)}}{w_{01}} = \frac{E(k) - B^2 l^2 [K(k) - (1 - B^2 c^2) \Pi(\rho, k)] - \frac{\pi (1 - B^2 c^2)}{2 \left(1 - \frac{c^2}{l^2}\right)} \sqrt{\left(\frac{l^2}{c^2} - 1\right) (1 - B^2 c^2)}}{E(k) - B^2 l^2 [K(k) - (1 - B^2 c^2) \Pi(\rho, k)] - \frac{\pi}{2} (1 - B^2 c^2) \sqrt{\left(\frac{l^2}{c^2} - 1\right) (1 - B^2 c^2)}}, \quad (54b)$$

$$Q_{20} = - \frac{\pi c^2}{2 \left(1 - \frac{c^2}{l^2}\right) \sqrt{1 - B^2 c^2} \left\{ E(k) - B^2 l^2 [K(k) - (1 - B^2 c^2) \Pi(\rho, k)] - \frac{\pi}{2} (1 - B^2 c^2) \sqrt{\left(\frac{l^2}{c^2} - 1\right) (1 - B^2 c^2)} \right\}}, \quad (54c)$$

$$Q_{21} = \frac{\pi B^2 c^3}{2 \left(1 - \frac{c^2}{l^2}\right) \sqrt{1 - B^2 c^2} \left\{ E(k) - B^2 l^2 [K(k) - (1 - B^2 c^2) \Pi(\rho, k)] - \frac{\pi}{2} (1 - B^2 c^2) \sqrt{\left(\frac{l^2}{c^2} - 1\right) (1 - B^2 c^2)} \right\}}, \quad (54d)$$

The constants k_{20} , k_{21} deduced in (34a), (34b), in which $w_{01}^{(1)}$ is substituted with the expression given by (54b).

For the determination of the coefficient of lift of half of the wing, we will start from (38) in which the expression $u'_{11} = \operatorname{Re} \mathcal{U}'_{11}$ will be introduced from (47) and we obtain:

$$C_l = \frac{8}{3\pi l U_\infty} \left[2Q_{20} c \cosh^{-1} \frac{l}{c} + Q_{21} l^2 \left(\sqrt{1 - \frac{c^2}{l^2}} + \frac{c^2}{l^2} \cosh^{-1} \frac{l}{c} \right) \right] =$$

$$= \frac{8 Q_{20}}{3\pi U_\infty} \frac{c}{l} \left[(2 - B^2 c^2) \cosh^{-1} \frac{l}{c} - B^2 l^2 \sqrt{1 - \frac{c^2}{l^2}} \right]. \quad (55)$$

The coefficient of the moment of roll is calculated starting from the relation (40)

$$HC_m = \frac{\sqrt{1 - \frac{c^2}{l^2}}}{U_\infty} \left[c Q_{20} + \frac{1}{3} Q_{21} (l^2 + 2c^2) \right] =$$

$$= \frac{Q_{20} c}{3 U_\infty} \sqrt{1 - \frac{c^2}{l^2}} \left[3 - B^2 (l^2 + 2c^2) \right], \quad (56)$$

in which the constant Q_{20} has the expression (54c), given above.

6. FINAL REMARKS

The results obtained above, in the case of torsioned wings, can be used with the plane delta wing in rotating motion around the axis of symmetry Ox_1 .

In this case however, due to permanent rotation of roll, it will be necessary therefore to make other considerations.

On the other part, we will remark that the position of vortex nuclei will be affected by a centrifugal effect, which pushes them towards the leading edges removing them, in the

case of great velocities of rotation, to greater distances,
even over 0.75 l.

Received by the editor on Jan. 10, 1969

BIBLIOGRAPHY

1. E. CARAFOLI, ȘT. STAICU, *Asupra teoriei aripii delta subfuzi cu separația curentului la vârfurile de atac*, St. cerc. mec. apl., 4 (1966).
2. E. CARAFOLI, *High-Speed Aerodynamics*, București, Edit. tehnică, 1956.
3. E. CARAFOLI, ȘT. STAICU, *Antisymmetrical thin delta wing with flow separation at the leading edges*, Rev. Roum. Sci. Techn.-Méc. Appl., XI, 6 (1966).
4. M. ROY, *Sur la théorie de l'aile delta. Tourbillons d'apex et nappes en cornets*, C. R. A. Sc., R. A. 56 (1957).
5. K. M. MÄNGLER, J. H. SMITH, *A Theory of the Flow Past a Slender Delta Wing with Leading Edge Separation*, Proc. Roy. Soc., May, 1959.
6. D. KÜCHEMANN, *A Non-Linear Lifting-Surface Theory for Wings of Small Aspect Ratio With Edge Separation*, R. A. E. Rep. 2540, April, 1955.
7. L. C. SQUIRE, *The Estimation of the Non-Linear Lift of Delta Wings at Supersonic Speed*, Journ. R.A.S., Aug. 1963.
8. W. H. MICHAEL, *Flow Studies on Flat-Plate Delta Wings at Supersonic Speed*, NACA TN 3472, July, 1955.
9. P. GERMAIN, *La théorie des mouvements homogènes et son application au calcul de certaines ailes delta en régime supersonique*, R. A., 7 (1949).
10. R. LEGRAND, *Nappes de tourbillons déferlant des bord d'attaque des ailes en delta*, ONERA Commun. Présenté au Symposium UTAM, Ann Arbor, 6-10 juillet, 1964.
11. E. CARAFOLI, ȘT. STAICU, *Sur un modèle théorique concernant l'aile delta mince avec décollement aux bords d'attaque*, Journal de Mécanique, 6, 2, Juin 1967, Paris.
12. E. CARAFOLI, ȘT. STAICU, *On the delta wing with forced antisymmetry in supersonic flow, considering the leading edge separation*, Rev. Roum. Sci. Techn.-Mécanique Appliquée, XII, 2 (1968).
13. E. CARAFOLI, ȘT. STAICU, *L'écoulement supersonique autour de l'aile delta arquée et gauche symétriquement, compte tenu de la séparation du courant aux bords d'attaques*, Rev. Roum. Sci. Techn.-Méc. Appliquée, XX, 3 (1969).

DISTRIBUTION LIST

DISTRIBUTION DIRECT TO RECIPIENT

<u>ORGANIZATION</u>	<u>MICROFICHE</u>	<u>ORGANIZATION</u>	<u>MICROFICHE</u>
A205 DMATC	1	E053 AF/INAKA	1
A210 DMAAC	2	E017 AF/RDXTR-W	1
B344 DIA/RDS-3C	9	E403 AFSC/INA	1
C043 USAMIIA	1	E404 AEDC	1
C509 BALLISTIC RES LABS	1	E408 AFWL	1
C510 AIR MOBILITY R&D LAB/FIO	1	E410 ADTC	1
C513 PICATINNY ARSENAL	1	E413 ESD	2
C535 AVIATION SYS COMD	1	FTD	
C591 FSTC	5	CCN	1
C619 MIA REDSTONE	1	ASD/FTD/NICD	3
D008 NISC	1	NIA/PHS	1
H300 USAICE (USAREUR)	1	NICD	2
P005 ERDA	1		
P005 CIA/CRS/ADB/SD	1		
NAVORDSTA (50L)	1		
NASA/KSI	1		
AFIT/LD	1		