

AD-A066 367

NAVAL POSTGRADUATE SCHOOL MONTEREY CALIF  
STOCHASTIC SEPARATION OF RADAR SIGNALS.(U)  
DEC 78 Z W SHLOMO

F/G 17/9

UNCLASSIFIED

NL

1 OF 3

AD  
A066367



LEVEL

(2)  
B.S.

# NAVAL POSTGRADUATE SCHOOL

Monterey, California

AD A0 66367

DDC FILE COPY.



DDC  
RECEIVED  
MAR 26 1979  
C  
*[Signature]*

## THESIS

STOCHASTIC SEPARATION OF RADAR SIGNALS

by

Shlomo (Weiss) Zach

December 1978

Thesis Advisor:

S. R. Parker

Approved for public release; distribution unlimited.

79 03 26 056

UNCLASSIFIED

SECURITY CLASSIFICATION OF THIS PAGE (When Data Entered)

REPORT DOCUMENTATION PAGE		READ INSTRUCTIONS BEFORE COMPLETING FORM
1. REPORT NUMBER	2. GOVT ACCESSION NO.	3. RECIPIENT'S CATALOG NUMBER
4. TITLE (and Subtitle) Stochastic Separation of Radar Signals		5. TYPE OF REPORT & PERIOD COVERED Ph.D. Thesis; Dec 1978
7. AUTHOR(s) Shlomo (Weiss)/Zach		6. PERFORMING ORG. REPORT NUMBER
9. PERFORMING ORGANIZATION NAME AND ADDRESS Naval Postgraduate School Monterey, California 93940		8. CONTRACT OR GRANT NUMBER(s) 9 Doctoral thesis
11. CONTROLLING OFFICE NAME AND ADDRESS Naval Postgraduate School Monterey, California 93940		10. PROGRAM ELEMENT, PROJECT, TASK AREA & WORK UNIT NUMBERS
14. MONITORING AGENCY NAME & ADDRESS (if different from Controlling Office) 10 Zach Weiss / Shlomo		12. REPORT DATE 11 December 1978
		13. NUMBER OF PAGES 224 (12) 225p.
		15. SECURITY CLASS. (of this report) Unclassified
16. DISTRIBUTION STATEMENT (of this Report) Approved for public release; distribution unlimited.		15a. DECLASSIFICATION/DOWNGRADING SCHEDULE
17. DISTRIBUTION STATEMENT (of the abstract entered in Block 20, if different from Report)		
18. SUPPLEMENTARY NOTES		
19. KEY WORDS (Continue on reverse side if necessary and identify by block number) Filter, Radar, Chaff, Modeling unresolved targets		
20. ABSTRACT (Continue on reverse side if necessary and identify by block number) There has been a continuing problem of estimating a radar signal when the noise and the signal have the same power spectra. This is particularly troublesome when one tries to resolve two close targets with a tracking radar. The purpose of this research is to show theoretically that there are practical ways to solve the problem.		

DD FORM 1473 1 JAN 73

EDITION OF 1 NOV 68 IS OBSOLETE  
S/N 0102-014-6601

UNCLASSIFIED

SECURITY CLASSIFICATION OF THIS PAGE (When Data Entered)

251 450

JOB

(20. ABSTRACT Continued)

Two approaches are introduced here. The first is to add a process filter to the radar, and the second is to design a new measuring technique with processing such that the signals will be separable. These two main approaches have led to several new or extended theories which were developed in the course of this work:

- + The Probability filter.
- + A modified Kalman filter (MKF).
- + A measurement modification technique for monopulse radar, *and*
- + A new approach to the design of a monopulse tracking radar.

Simulations were performed to check the two major theories (the M.K.F. and the probability filter). According to the simulations we can say that a tracking radar can be modified in order to solve the problem of separating unresolved targets.



ACCESSION for		<input checked="" type="checkbox"/>
NTIS	DTIC	<input type="checkbox"/>
DOC	B H S	<input type="checkbox"/>
UNCLASSIFIED		
JUS-1		
BY		
DISTRIBUTION		
DATE		
A		

79 03 26 056

Approved for public release; distribution unlimited.

Stochastic Separation of Radar Signals

by

Shlomo (Weiss) Zach  
Lieutenant, Israeli Navy  
B.Sc, Technion, Israel Institute of Technology, 1970  
M.S., Naval Postgraduate School, 1977

Submitted in partial fulfillment of the  
requirements for the degree of

DOCTOR OF PHILOSOPHY

from the

NAVAL POSTGRADUATE SCHOOL  
December 1978

Author

*Shlomo Zach*

Approved by:

*H. A. Titus*  
H. A. Titus  
Professor of Electrical Engineering

*G. A. Myers*  
G. A. Myers  
Associate Professor of  
Electrical Engineering

*I. B. Russak*  
I. B. Russak  
Professor of Mathematics

*A. R. Washburn*  
A. R. Washburn  
Associate Professor of  
Operations Research

*S. R. Parker*  
S. R. Parker  
Professor of Electrical Engineering  
Thesis Advisor

Approved by *W. K. Kik*  
Chairman, Department of Electrical Engineering

Approved by *Jay R. Bortus*  
Academic Dean

## ABSTRACT

There has been a continuing problem of estimating a radar signal when the noise and the signal have the same power spectra. This is particularly troublesome when one tries to resolve two close targets with a tracking radar. The purpose of this research is to show theoretically that there are practical ways to solve the problem.

Two approaches are introduced here. The first is to add a process filter to the radar, and the second is to design a new measuring technique with processing such that the signals will be separable. These two main approaches have led to several new or extended theories which were developed in the course of this work:

- The Probability filter.
- A modified Kalman filter (MKF).
- A measurement modification technique for monopulse radar.
- A new approach to the design of a monopulse tracking radar.

Simulations were performed to check the two major theories (the M.K.F. and the probability filter). According to the simulations we can say that a tracking radar can be modified in order to solve the problem of separating unresolved targets.

TABLE OF CONTENTS

I.	INTRODUCTION -----	10
	A. SEPARATION OF SIGNALS -----	10
	B. APPLICATION TO TRACKING RADAR -----	23
II.	BACKGROUND THEORY -----	28
	A. INTRODUCTION TO TRACKING RADAR -----	28
	B. TRACKING BY RADAR -----	28
	1. Angle Tracking -----	29
	a. Conical Scan (C.S.) -----	29
	b. Lobe Switching (L.S.) -----	35
	c. Monopulse Method -----	37
	2. Range Tracking -----	47
III.	STATEMENT OF THE PROBLEM -----	51
	A. INTRODUCTION. INTERFERENCE CAUSED BY TWO TARGETS -----	51
	B. INTERFERENCE IN ANGLE CREATED FROM TWO TARGETS -----	52
	C. INTERFERENCE IN RANGE MEASUREMENT CAUSED BY TWO TARGETS -----	55
	D. CONCLUSION -----	59
IV.	A MODIFIED ANTENNA AND KALMAN FILTER, SOLUTION FOR UNRESOLVED TARGETS - FOR A MONOPULSE SYSTEM ---	61
	A. THE THEORETICAL SOLUTION -----	61
	1. Introduction -----	61
	2. Resolving Targets with Monopulse System ---	62
	3. The Filtering Procedure -----	81
	a. The Selection Procedure -----	86
	b. Filtering -----	88

B.	SIMULATION OF THE MODIFIED KALMAN FILTER -----	89
1.	Introduction -----	89
2.	Simulation Results -----	94
a.	Influence of the Noise on the Performance of the Filter -----	94
b.	Influence of the mean of X(0) to the Performance of the Filter -----	96
c.	Influence of the Standard Deviation of the Initial State to the Performance of the Filter -----	103
d.	The Gain as a Function of Time -----	108
3.	Conclusion of the M.K.F. Simulations -----	111
V.	THE SOLUTION FOR THE UNRESOLVED TARGETS FOR C.S. OR L.S. - THE PROBABILITY FILTER -----	112
A.	THE THEORETICAL SOLUTION -----	112
B.	PROBABILITY FILTER SIMULATION -----	113
1.	Introduction -----	113
2.	Open Loop Performances - One Parameter ---	116
a.	Testing $\partial I/\partial Y$ -----	120
b.	Estimation of $\theta$ in Open Loop -----	120
3.	Close Loop Performances - One Parameter --	129
4.	Estimation of Several Parameters by the Probability Filter -----	134
a.	Introduction -----	134
b.	Mathematical Equation -----	137
c.	Open Loop Performances -----	141
d.	Estimation of Parameters in Case of p.d.f. Not Known Exactly -----	145
5.	Conclusion of the Probability Filter Simulations -----	153

VI. SUMMARY AND CONCLUSIONS -----	155
APPENDIX A: MODIFIED KALMAN FILTER FOR THE CASE THAT THE MEASUREMENT COMES FROM TWO DIFFERENT SOURCES -----	157
APPENDIX B: THE MULTIVARIABLE NORMAL DISTRIBUTION ---	181
APPENDIX C: TRANSFORMATION OF RANDOM VARIABLES -----	187
APPENDIX D: SEPARATION OF SIGNALS BY PROBABILITY FILTER -----	191
APPENDIX E: THE MAXIMUM LIKELIHOOD ESTIMATOR -----	212
APPENDIX F: ESTIMATION FOR SYSTEM DESCRIBED BY DIFFERENTIAL/DIFFERENCE EQUATION -----	213
LIST OF REFERENCES -----	220
INITIAL DISTRIBUTION LIST -----	223

### ACKNOWLEDGMENT

To my advisor, Professor Sydney R. Parker, I wish to express deep appreciation for his guidance in my research. I would like to thank all the members on my doctoral committee for their time and suggestions for improvement in my research. I give special thanks to Professors D.E. Kirk, H.A. Titus, F.D. Faulkner and Cdr. McGonigal for their time and effort in helping me in various ways during the research.

Finally, I thank my wife Sarah for her love, patience, devotion and inspiration, without which this work could not possibly have been done.

LIST OF ABBREVIATIONS

- A.C.F. - Autocorrelation function
- A.G.C. - Automatic gain control
- A.Z. - Azimuth
- C.A. - Complex angle
- C.D.F. - Cumulative distributed function
- C.S. - Conical scan
- EL - Elevation
- Im - Imaginary part of
- L.O.S. - Line of sight
- M.K.F. - Modified Kalman filter
- M.L.E. - Maximum likelihood estimator
- M.T.I. - Moving target indicator
- P.D.F. - Probability density function
- P.R.F. - Pulse repetition frequency
- P.R.R. - Pulse repetition rate
- R.C.S. - Radar cross section
- RE - Real part of
- R.K.F. - Regular Kalman filter
- S.N.R. - Signal to noise ratio (S/N)
- T.W.S. - Track while scan
- $\bar{x}$  - Means vector  $\bar{x} \triangleq (x_1, x_2, \dots, x_n)^T$

## I. INTRODUCTION

### A. SEPARATION OF SIGNALS

In many cases we would like to separate two signals from a measurement which is a function of their combination, such as their sum. One of the signals is usually "noise" and the other the "signal" or "information." Techniques of separating two signals if they have different power spectra are well known, for example, the Kalman filter or the Weiner filter. The case when the two signals have almost the same power spectra does not appear in the literature, mostly because each problem must be treated in a different way. The following are two basic approaches to this problem:

(i) Use all of the statistical information about the signal to effect the separation.

(ii) Design measuring techniques such that the two signals will be separable in some sense.

The specific application to be addressed in this research is the tracking radar case where it is necessary to separate a target return from chaff. The sections which follow present a summary of the basic theory with reference to the literature. Some new results have been achieved and are presented in the body of the text. They include:

- a) The separation of the two signals by means of a probability filter - Appendix D
- b) A modified Kalmak filter approach - Appendix A.

- c) A new measurement modification technique for mono-pulse radar - Section (IV.A).
- d) A new approach to a tracking radar design - Chapter IV.

The following examples are given as part of this introduction to show that separation of two signals with the same power spectra is plausible.

The objective is to estimate the strength of a signal in the presence of noise when the noise and the signal have identical or almost identical power spectra. In those cases (where we can't effectively separate the signals in the frequency domain) we will consider the processes of identifying the signals in the probability or statistical domain. Consider the following:

Example 1-1

It is desired to separate a signal from noise when they both have a uniform probability density function (p.d.f.) of different widths. The amplitude of the noise and the signal are unknown and it is assumed that there is no correlation between them. The measurement is the sum of the signal and the noise. Thus, we assume that:

- 1) The noise and the signal are statistically independent.
- 2) Both have uniform distributions.
- 3) The measured signal is given by:

$$Z = S + N$$

It is desired to estimate the amplitude of the signal. From statistics we know that  $Z$  has a p.d.f. which is given by the convolution between the two p.d.f., (see Fig. 1-1). By inspection of this figure we can see that the p.d.f. of  $Z$  contains information about the amplitude of the two signals. Note that without prior information about  $A_1$  or  $A_2$  we can only determine the two amplitudes, without being able to state which is signal and which is noise. The separation technique would involve calculation of the p.d.f. of  $Z$ . Also, this filter can only give us the amplitude of the signal and not the whole signal.

Example 1-2

Consider the case where the signal is a square wave between levels,  $(A_1 + A_2)$  and  $A_2$ , where the switching time,  $\tau$ , is a random variable with given statistics. The noise is the same type of signal with levels  $(B_1 + B_2)$  and  $B_2$ . Assume that the amplitudes ratio is given:

$$A_1/A_2 = K_1 \tag{1-1}$$

$$B_1/B_2 = K_2$$

Figure 1-2 identifies the signal and the noise. Figure 1-3 identifies the p.d.f. of the combined signal plus noise. With the p.d.f. for  $Z = S + N$  and the given ratios  $K_1$  and

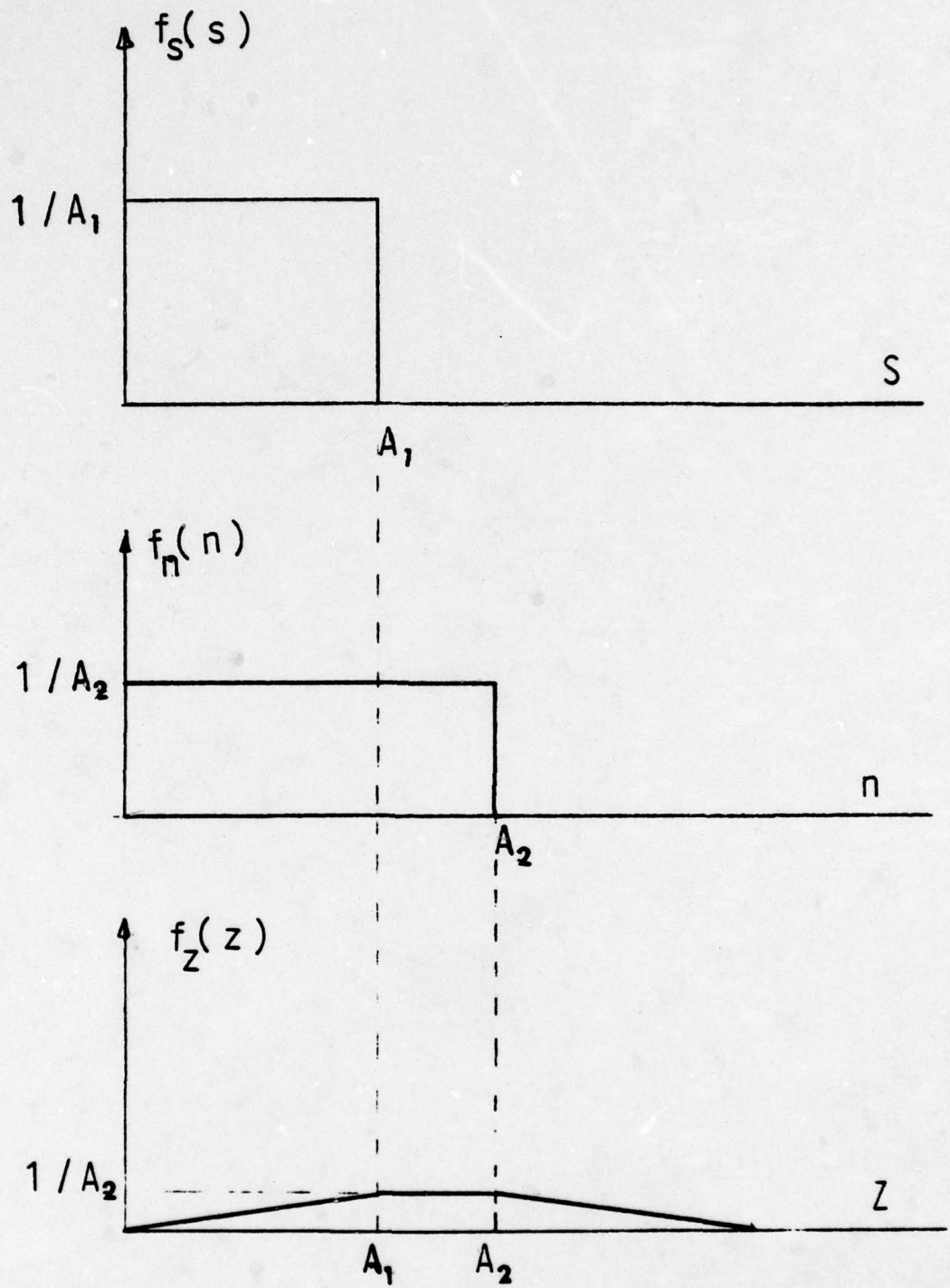

Figure 1-1. p.d.f. of two signals and the p.d.f. of their sum. (Refer to example 1-1).

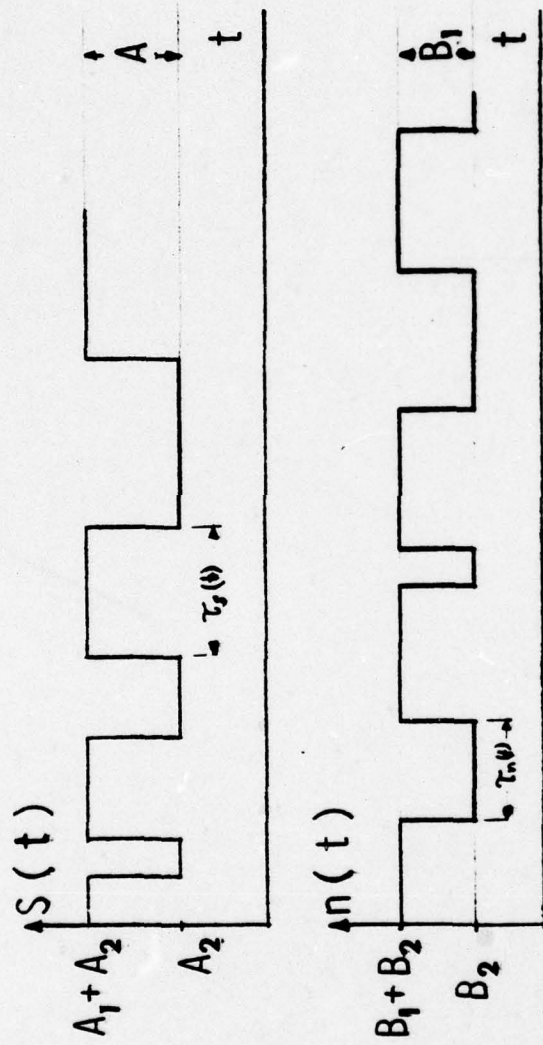
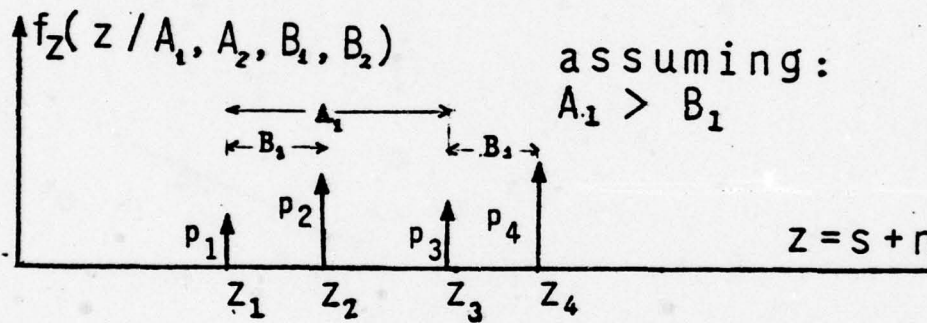
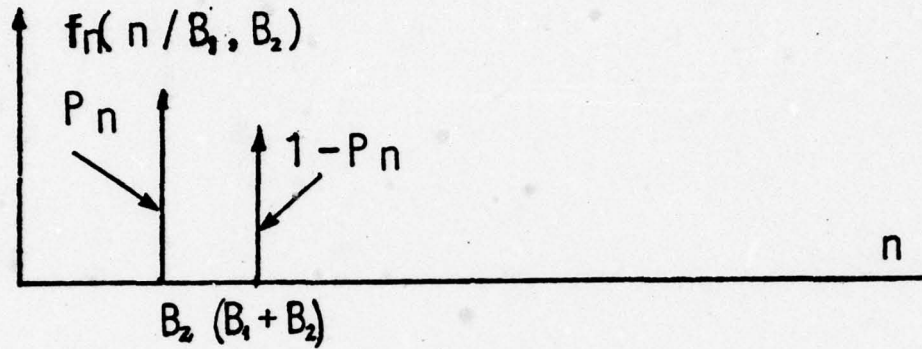
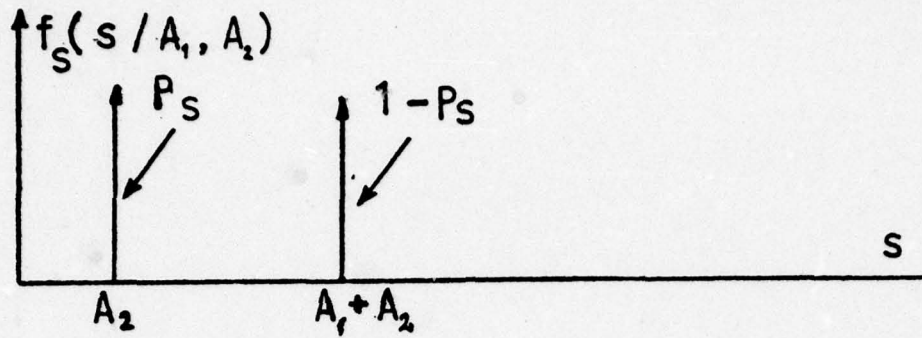

Figure 1-2. Typical time representation of the signal and noise.



$$\begin{aligned}
 p_1 &= p_s p_n \\
 p_2 &= p_s (1 - p_n) \\
 p_3 &= (1 - p_s) p_n \\
 p_4 &= (1 - p_s) (1 - p_n)
 \end{aligned}$$

$$\begin{aligned}
 z_1 &= A_2 + B_2 \\
 z_2 &= A_2 + B_2 + B_1 \\
 z_3 &= A_2 + B_2 + A_1 \\
 z_4 &= A_2 + B_2 + A_1 + B_1
 \end{aligned}$$

Figure 1-3. The p.d.f. of the signal plus noise.

$K_2$ , one can compute the amplitudes and even determine the signal  $S$  uniquely as follows:

Let us assume that  $A_1 > B_1$ , then the estimated values of  $S$  denoted by  $\hat{S}$  will be (refer to fig. 1-3):

$$\hat{S} = \begin{cases} A_2 & \text{if } z_1 \text{ or } z_2 \\ A_1 + A_2 & \text{if } z_3 \text{ or } z_4 \end{cases} \quad (1-2)$$

And for the case,  $B_1 > A_1$ :

$$\hat{S} = \begin{cases} A_2 & \text{if } z_1 \text{ or } z_3 \\ A_1 + A_2 & \text{if } z_2 \text{ or } z_4 \end{cases} \quad (1-3)$$

**Notes:**

- (i) In this example there is no assumption one way or the other about correlation between the signal and the noise.
- (ii) The two cases ( $A_1 > B_1$  or  $A_1 < B_1$ ) can be easily determined by checking the p.d.f., (the four levels) and comparing  $K_1$  and  $K_2$ .
- (iii) The levels can be computed easily by the four equations:

$$z_1 = A_2 + B_2$$

$$Z_2 = \begin{cases} A_2 + B_2 + B_1 & \text{if } A_1 > B_1 \\ A_1 + A_2 + B_2 & \text{if } A_1 < B_1 \end{cases} \quad (1-4)$$

$$Z_3 = \begin{cases} A_2 + B_2 + A_1 & \text{if } A_1 > B_1 \\ B_2 + A_2 + B_1 & \text{if } A_1 < B_1 \end{cases}$$

$$Z_4 = A_2 + A_1 + B_1 + B_2$$

And the cases  $A_1 > B_1$  or  $A_1 < B_1$  can be determined by the two ratios:

$$A_1/A_2 = K_1$$

$$B_1/B_2 = K_2$$

- (iv) The signal can be determined even if the noise is the sum of a square wave plus random noise (for example, white Gaussian). In this case we have to introduce the statistics of the switching time  $\tau(t)$  and the random noise.

In the noise free case we can show the processor by a simple block diagram given in Fig. 1-4.

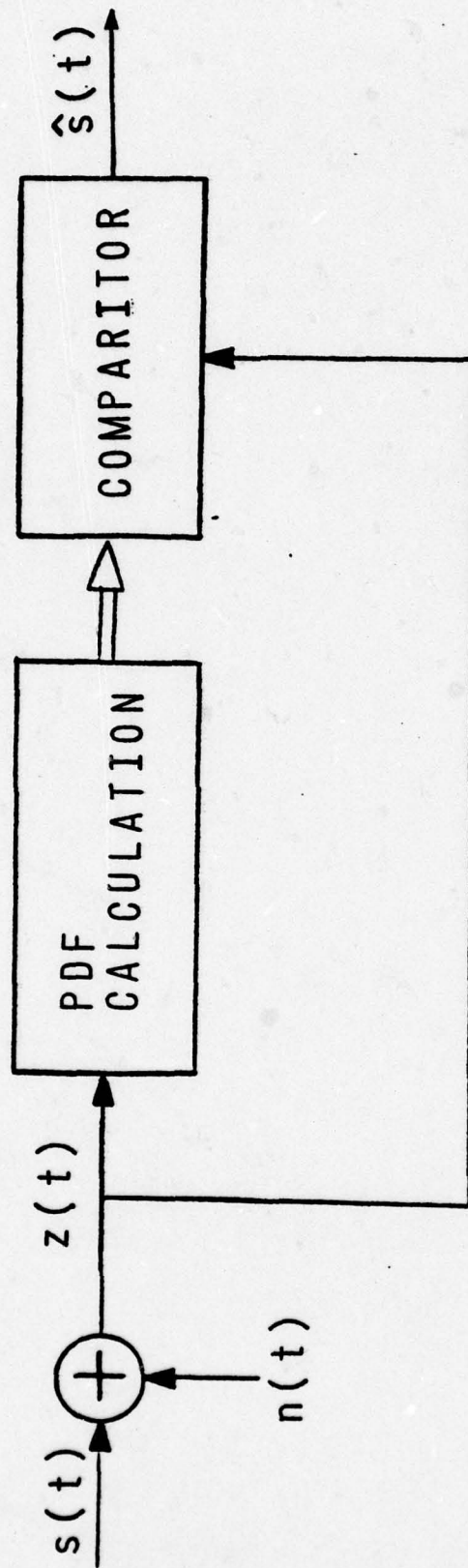

Figure 1-4. Block diagram of the processor given for example 1-2.

In these two simple examples, it has been shown that in some cases signals can be separated from the noise, or the parameters of the signal determined, even if they have the same power density spectrum. Thus, the idea of filtering a signal in the probability domain seems plausible.

A second possibility of separation to somehow change the measurement, seems reasonable. An example would be in a control system where we design our measurement such that the system will be observable (see next example).

### Example 1-3

Consider the case where the measurement and the state equation is given by:

$$\underline{\tilde{x}}(K+1) = \underline{\tilde{x}}(K) + \underline{u}(K)$$

$$\underline{\tilde{z}}(K) = C\underline{\tilde{x}}(K) + \underline{v}(K)$$

In the case where the system is not observable there is no way to estimate  $\underline{\tilde{x}}$  unless we change something in the system. One way to do it is to change the matrix  $C$ , so that the system will be observable. Let's now consider a practical example related to the dissertation. We will consider the conical scan radar (see next chapter for details). In c.s. we often have the problem of cross talk between the two channels ( $A_z$  and  $FL$ ). A simplified block diagram of the radar is given in fig. 1-5. The system can be described by:

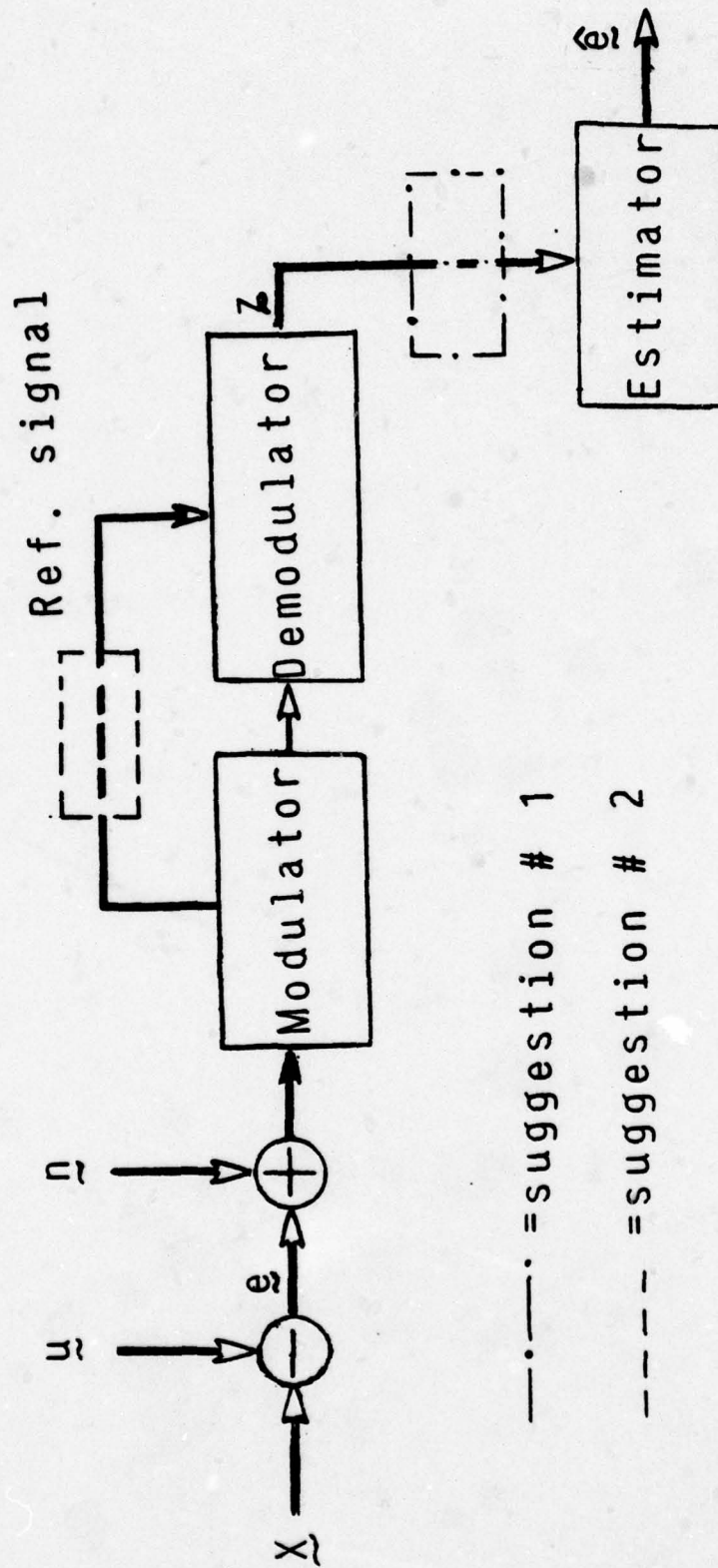

Fig. 1-5. Simplified block diagram of C.S. error estimator.

$$\underline{e}(K) = \underline{X}(K) - \underline{U}(K)$$

$$\underline{z}(K) = C(\underline{e}(K) + \underline{n}(K))$$

where all the vectors are two dimensional and the matrix C is given by:

$$C = \begin{bmatrix} 1 & a \\ b & 1 \end{bmatrix}$$

$\underline{e}(k)$  contains the errors in both  $A_z$  and  $E_L$ .  $a$  and  $b$  are the cross table factors in the measurement.

Obviously where  $a = b = 1$  the system is not observable and we can't estimate the error (the target position). In the case of an observable system, but with  $a$  and  $b$  close to one, the regular Kalman filter estimator converges slowly. In order to improve the time constant of the estimator one suggestion is to change  $Z$  to  $Z'$  by (see fig. 1-5 suggestion #1):

$$\underline{z}'(K) = E \cdot \underline{z}(K)$$

where

$$E = \begin{bmatrix} 1 & -a \\ -b & 1 \end{bmatrix}$$

This will lead to a new measured vector ( $Z'(K)$ ) given by:

$$Z'(K) = (1-ab) (\underline{e}(K) + \underline{n}(K))$$

This suggestion will solve the cross talk problem but it will increase the effects of the noise  $\underline{n}$ . The problem will be solved only if  $a \cdot b \neq 1$ . So another way must be found. This can be done quite easily by changing the modulator reference signals. The solution will be that  $C \rightarrow I$  and the statistics of the new measured noise will be almost the same as the given noise and this is indeed an improvement of the system performances (see fig. 1-5 suggestion #2). The details are beyond the scope of this chapter.

The situation of having the signal and noise with approximately the same power spectra occurs in radar. For example, we may have:

- (i) Target plus clutter.
- (ii) Target plus target in the same resolution cell.

The work which follows will concentrate on the tracking radar case. We will treat the problem with two major approaches:

- (i) Assume that the radar receiver is given and we have to process the output signal. This will give us the possibility to try to work the problem using the first proposed technique.

(ii) Assume that we can change the receiver and also make some changes in the antenna such that we will get a new measured signal from the receiver which will allow us to separate the two signals coming from two different sources (targets). This is the second proposed technique.

Because the second approach will give us the most powerful results, we will concentrate mainly on this approach, but we will include all of the information necessary for the first approach.

#### B. APPLICATION TO TRACKING RADAR

In radar tracking we can have the real target and the false target (chaff, clutter) which are in the same resolution cell. ( $\Delta R < \frac{c}{2} \Delta t$ ,  $\Delta \alpha < \theta_{3db}$ , where  $\Delta t$  = pulse length,  $\theta_{3db}$  = beamwidth of the antenna.) Because of the false target, we cannot measure the position of the real target (angles and range). For tracking, we must be able to measure the error in range, azimuth and elevation where the error equals the deviation of the actual target position from the estimated position as given by the midpoint of the resolution cell. In order to accomplish this, the radar has two (at least) windows for each coordinate. The "weight" of the target in each window is measured by the difference between the normalized weights of each window for each coordinate, which is used in calculation to determine target position.

Example 1-4

In range we have two gates, the early and late gates. By measuring the weight of each gate we compute the error in range as:

$$\Delta R = R_0 \frac{V_{EG} - V_{LG}}{V_{EG} + V_{LG}} \quad (1-5)$$

$$R_0 = c \cdot \Delta\tau/2$$

where:

- (i)  $\Delta R$  - the computed error in range.
- (ii)  $2\Delta\tau$  - the width of the range gate.
- (iii)  $t_0$  - the position of the range gate.
- (iv)  $C$  - velocity of light.

$$(v) \quad V_{EG} = \int_{t_0 - \Delta\tau}^{t_0} V(t) dt$$

$$(vi) \quad V_{LG} = \int_{t_0}^{t_0 + \Delta\tau} V(t) dt$$

- (vii)  $V(t)$  - the received signal.

The time representation of the range gates, received signal (video),  $V_{EG}$  and  $V_{LG}$ , is given in Fig. 1-5.

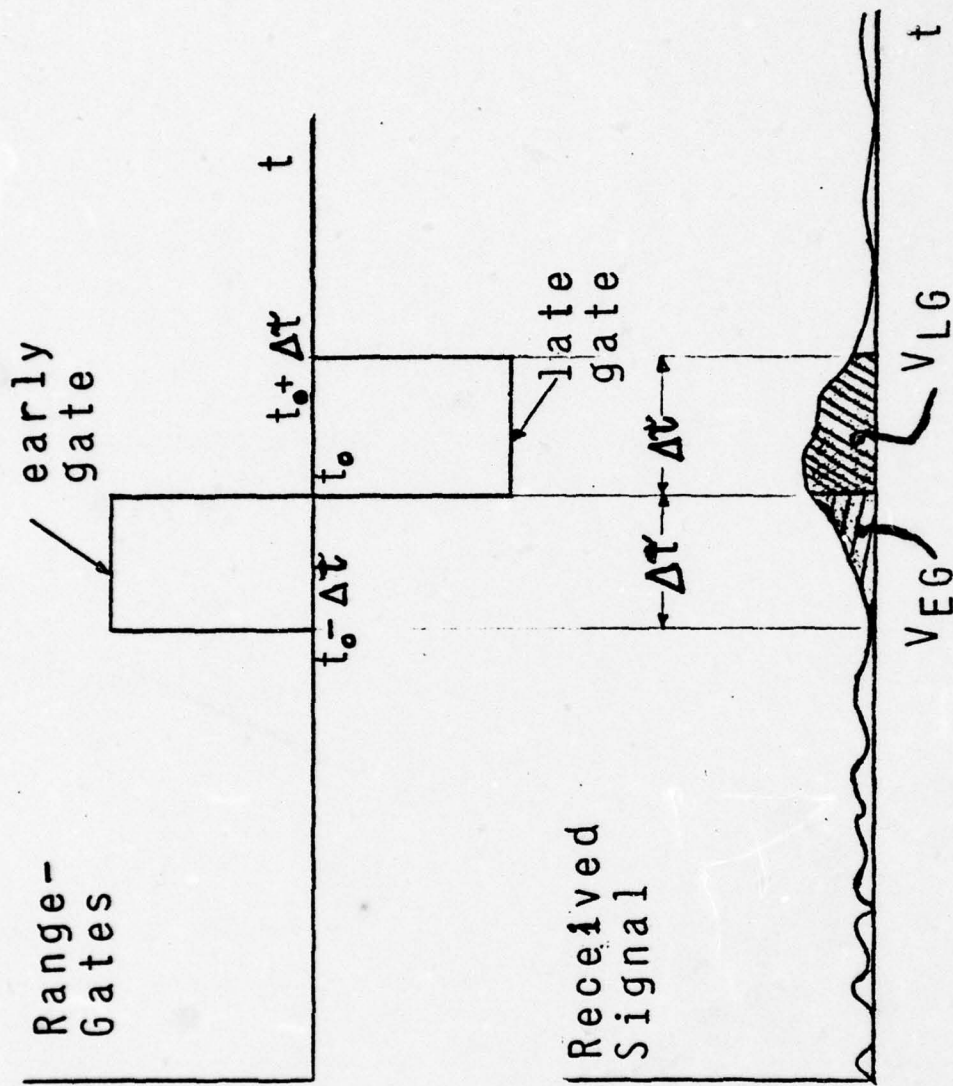

Figure 1.6. Time representation of the range gates, received signal (video)  $V_{EG}$  and  $V_{LG}$ .

The same type of equation holds for the angle. In this case we have two or more antennas for azimuth, and two antennas for elevation. In this technique we estimate the weight of the real target in each window, and compute the error to close the tracking loop and try to reduce the errors to zero. When we have two targets in the same resolution cell, the computed error would depend upon the "center of gravity" (radar center) of the radar return of the two targets. Because the two targets have the same (or almost the same) power density spectra, we cannot distinguish between them by spectral analysis; thus we have the problem discussed in Section I.A.

The object of this research is to estimate the true position of the target when the false target is near the true target. In the research we apply the following practical constraints:

- (i) An estimator which can be used on small missiles. We need simple algorithms so that the memory size and the amount of computation will be reasonable.
- (ii) The size of the antenna is fixed, and we are restricted to an antenna of reasonable structure. For example we can use a monopulse antenna with changes (referred to regular monopulse) but we cannot use an antenna with more than four outputs.

- (iii) We will not search for a solution in the r.f. range because for each r.f. it is possible to have counter measure chaff adapted to that frequency or frequencies.
- (iv) We will restrict ourselves to surface targets which imply no reasonable Doppler shift between the two targets. In the problem of air targets the difference in velocity between the target and the chaff is distinguishable and they can be separated easily by a moving target indicator (MTI).

## II. BACKGROUND THEORY

### A. INTRODUCTION TO TRACKING RADAR

Before we establish the problem and our solution we present a short summary of pertinent tracking radar theory.

The function of tracking radar is to select a particular target and follow its course in range, angle and sometimes frequency (a direct measurement of velocity) coordinates.

### B. TRACKING BY RADAR

Tracking systems can be achieved by two different techniques.

#### Track-while-scan (TWS)

This method of tracking basically uses data from search radar. The idea is to take a sample measurement of the target each time that the antenna is pointed to the tracked target. This tracking class is not of interest in this study.

#### Continuous Tracking Radar

In this method of tracking, the antenna is always directed at the target due to function of a control system. There are several methods of tracking (i.e., method of generating the error signals to close the antenna position and the range loops). The important methods are:

- (i) Conical scan (C.S.)
- (ii) Lobe switching (L.S.)
- (iii) Monopulse.

Those methods are distinguished by their difference in angle tracking. The principle of range tracking is almost the same for all the radars. Since the most accurate and interesting case for us is the monopulse, we will concentrate on it. However the theory of the other techniques is summarized.

1. Angle Tracking

a. Conical Scan (C.S.). In C.S. systems, angles are measured by a single antenna, whose radiation pattern rotates periodically about a certain axis. When the target is in the axis direction, the radar will have a constant return signal. The coordinates of the off axis target is determined on the basis of comparison to the envelope of received signals with a reference signal. For this reason we can not measure the error in one pulse but we have to wait at least one period of antenna scan to get the information. A simplified block diagram of the C.S. system is given in Fig. 2-2.1. The antenna A, scans in space with angular frequency,  $\Omega$ . Two references for the phase detector are generated by the antenna (AZ. ref. and EL. ref.). The position of the antenna is controlled by the control system. Assume a target at position T. Because the target is assumed to be off the axis of rotation, the echo signal will be modulated at frequency  $\Omega$  (the C.S. frequency). The amplitude of the signal depends on the position of the target with respect to axis of rotation, and the phase will

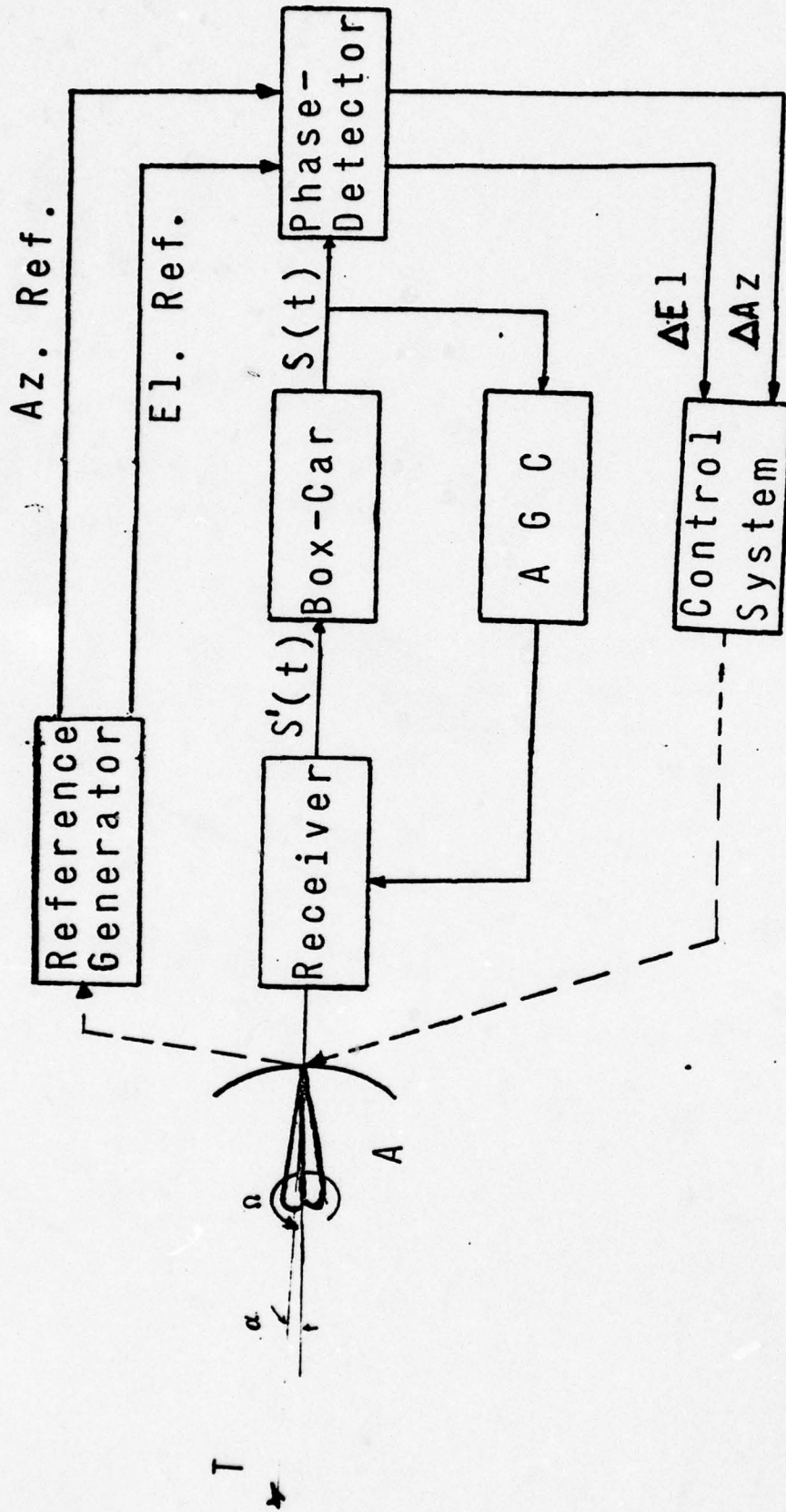

----- = meacanical signal

Figure 2.2-1. Block diagram of C.S. system.

depend on the direction of the angle between the target and the rotation axis. When the antenna is on the target we will get zero modulation at the receiving signal (see Fig. 2-2.2). The modulation pulses pass through a receiver which is controlled by an AGC (automatic gain control). We will see later on why the AGC is needed. The signal then passes through a "box-car" circuit which changes the amplitude modulated pulses into a signal close to sinusoid. This signal passes through two-phase detectors (for Az. and EL.). The outputs from the phase detectors are the errors in EL and Az, and by using these errors we can close the loop on a control system which will move the antenna to reduce the error to zero, so that the antenna "looks" towards the target. We can write the amplitude of the signal at the output of the receiver as:

$$S'(t, \theta_T) = S_0 \cdot G_{av}(\theta_T) [1 + m(\theta_T) \cos(\Omega t + \phi_c)] \quad (2.2-1)$$

where

$S'(t, \theta_T)$  = envelope of the amplitudes of a sequence of radar return pulses.

$S_0$  = the amplitude of the signal (dependent on the RCS (Radar Cross Section) of the target, the range, the gain of the receiver, etc.)

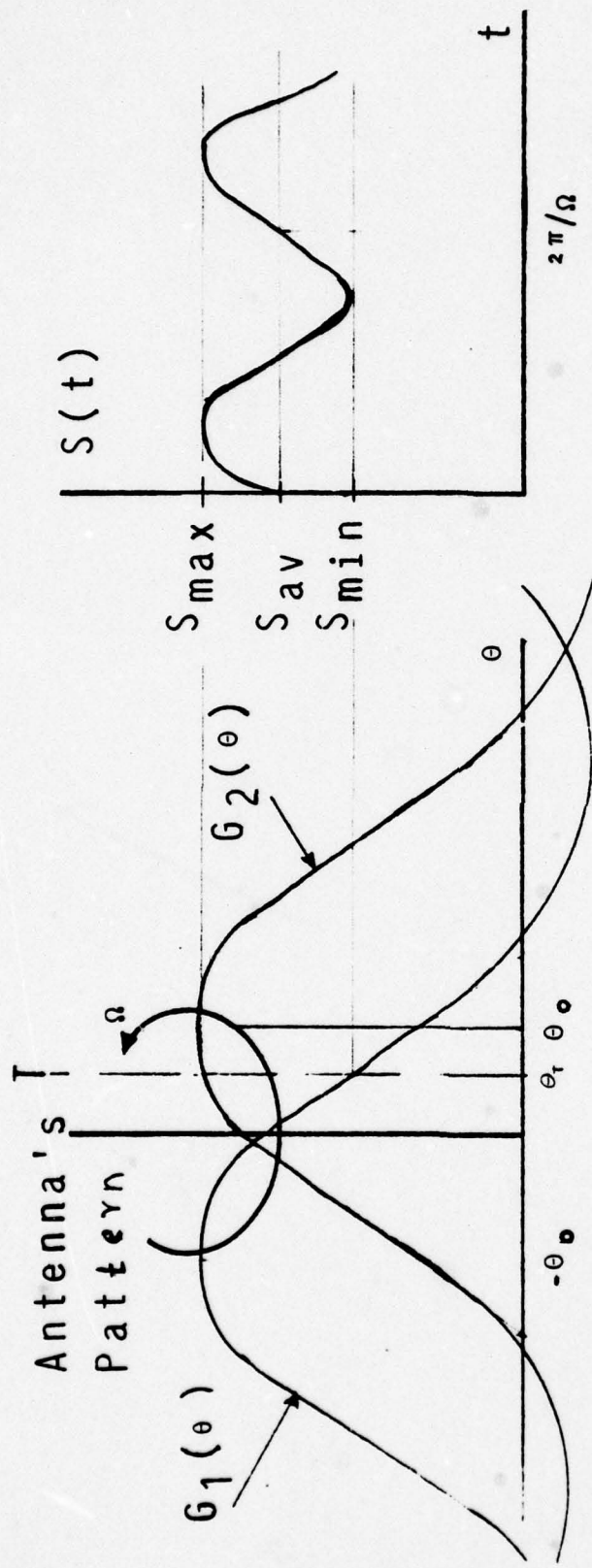

Figure 2.2-2. Principle of modulation of the error signal in C.S.

$G_{av}(\theta_T)$  = the average gain of the antenna, in the direction of the target, which can be determined approximately by

$$G_{av}(\theta_T) = \frac{G(\theta_o - \theta_T) + G(\theta_o + \theta_T)}{2} \quad (2.2-2)$$

to a first order of approximation, this average gain is constant, i.e., independent of  $\theta_T$ .

$\theta_T$  = The position angle of the target.

$\Omega$  = Conical scan frequency of the antenna.

$\phi_c$  = Phase of signal relative to C.S. frequency.

$m(\theta_T)$  = The modulation index which is approximately equal to:

$$m(\theta_T) = \frac{S_{\max}(\theta_T) - S_{\min}(\theta_T)}{2 \cdot S_{av}} \quad (2.2-3)$$

$$= \frac{G(\theta_o - \theta_T) - G(\theta_o + \theta_T)}{G(\theta_o - \theta_T) + G(\theta_o + \theta_T)}$$

where (see Fig. 2.2-2)

$S_{\max}$  - is the maximum received signal

$$= S_o(G(\theta_o - \theta_T) + G(\theta_o + \theta_T)).$$

$S_{\min}$  - is the minimum received signal

$$= S_0 (G(\theta_0 - \theta_T) - G(\theta_0 + \theta_T))$$

$$S_{av} = \frac{S_{\max} + S_{\min}}{2}$$

Because we would like to have the same amount of error for the same error angle, independent of the target and range, we have to measure the modulation index. The method which is usually used to achieve this objective is the AGC (automatic gain control). The purpose of the AGC is to fix  $S_{av}$  such that  $S_{av}$  will be a constant. This can be accomplished by controlling the gain of the receiver. The signal can be represented by:

$$S'(t, \theta_T) = C[1 + m(\theta_T) \cos(\Omega t + \phi_C)] \quad (2.2-4)$$

where  $C$  is a known constant, independent of the target RCS and other parameters.

If we pass the signal through a highpass filter, we will get (after the Box-Car):

$$S(t_1, \theta_T) = C m(\theta_T) \cos(\Omega t + \phi_C) \quad (2.2-5)$$

Now we have a signal with its amplitude proportional to  $m(\theta_T)$ , and phase equal to  $\phi_C$ . With both of these we can determine the error signal after the phase detector:

$$\Delta Az = K \cdot m(\theta_T) \cos \phi_C \quad (2.2-6)$$

$$\Delta EL = K \cdot m(\theta_T) \sin \phi_C$$

Because  $m(\theta_T)$  depends on the antenna parameters, the error measured by the system will not be a linear function of  $\theta_T$ . The error signals can be determined linearly only for small displacement angles.

b. Lobe Switching (L.S.) The method of L.S. is achieved by switching the antenna beam between four positions (two positions per direction). We will describe the method in one dimension since the two dimensions case is a straightforward extension of the one-dimensional situation. Refer to Fig. 2.2-3. Because we have two antennas and we switch between them, the receiver output belongs to antenna 1 ( $S_1$ ) and to antenna 2 ( $S_2$ ). As in the C.S. system because of AGC,  $S_1 + S_2$  equal a constant and the error can be determined by the difference between  $S_1$  and  $S_3$ , i.e.,

$$\text{error}(\theta_T) = K[S_1(\theta_T) - S_2(\theta_T)] \quad (2.2-7)$$

If we have four antennas, by AGC, we keep  $S_1 + S_2 + S_3 + S_4$  equal to a constant, so then:

$$\Delta Az = K[(S_1 + S_2) - (S_3 + S_4)] \quad (2.2-8)$$

$$\Delta EL = K[(S_1 + S_3) - (S_2 + S_4)]$$

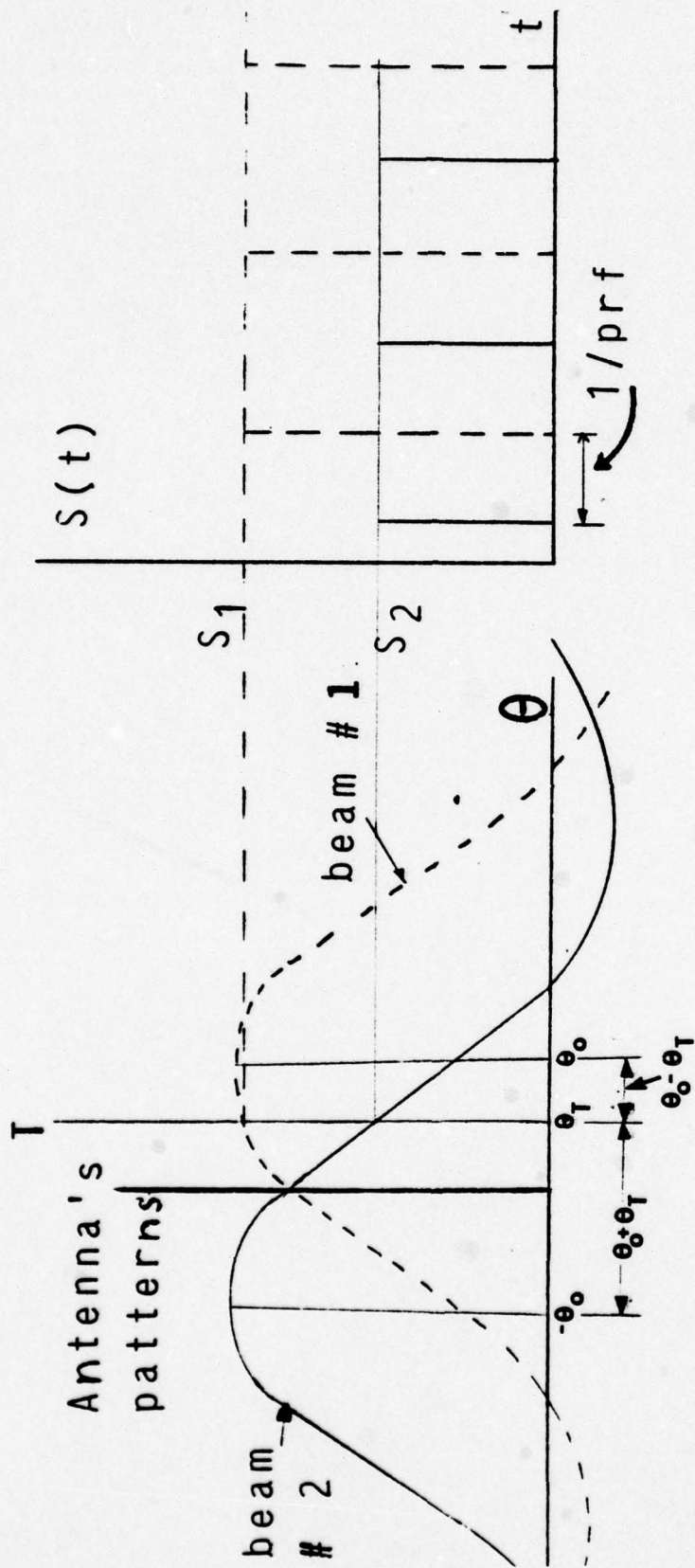

Figure 2.2-3. L.S. antenna pattern and output signal (one-dimensional only).

c. Monopulse Method. In the two previous methods (C.S. and L.S.), the measurement of angular error in two coordinates (AZ and EL) requires that a minimum of three pulses be processed. In practice, the minimum number of pulses in L.S. usually requires four pulses (one for each antenna). C.S. usually requires much more than four (20 pulses is a "good" number - which is dependent on the frequency of the C.S. and the P.R.F.). The requirement for both of them is that during the scanning or switching the signal amplitude does not contain additional modulation components other than the modulation given by the antenna. If the amplitude contains additional modulation components, the tracking accuracy might be degraded, especially if the frequency components of the fluctuations are close to the C.S. frequency or the L.S. rate. These functions can be caused, for example, by a fluctuating target cross-section. In order to avoid this problem, we prefer to base our measurements on one pulse rather than many. When a signal is received by two different antennas, the difference between the two signals might be one of phase and/or amplitude. This is the premise of the monopulse radar, i.e., use the difference between signals arriving at the same time by the antenna. The name monopulse is used to describe those techniques which derive angle-error information on the basis of a single pulse. (Note: In some cases monopulse is called "simultaneous lobing.")

Two major techniques are used in monopulse:

- (i) Measuring the relative phase of the carrier of the I.F. between the pulses coming from each antenna.
- (ii) Measuring the relative amplitude of the pulse received in each beam.

Fig. 2.2-4 presents a block diagram of general monopulse (i.e., amplitude - phase type), for one coordinate. We will see later that by zeroing the distances between the antennas, i.e.,  $d = 0$ , the system reduces to amplitude comparison monopulse, and by zeroing the tilted angle, i.e.,  $\theta_0 = 0$ , it reduces to phase-comparison monopulse. The extension into two dimensions is straightforward. In most of the cases the sum and the difference are taken with the r.f. signal (right after the antenna), after which there are two receivers (one for sum channel and one for the difference channel). This is because of practical reasons:

- (i) Only the r.f. channel receiver must be identical.
- (ii) For two-dimensions we save one receiver (3 versus 4).

In the analysis which follows we will show the sum and difference taken in the i.f. This change does not make any difference for monopulse radar but it is necessary for the complex angle (CA) method. The signals received from the target at antennas  $A_1$  and  $A_2$  are fed to the receiver

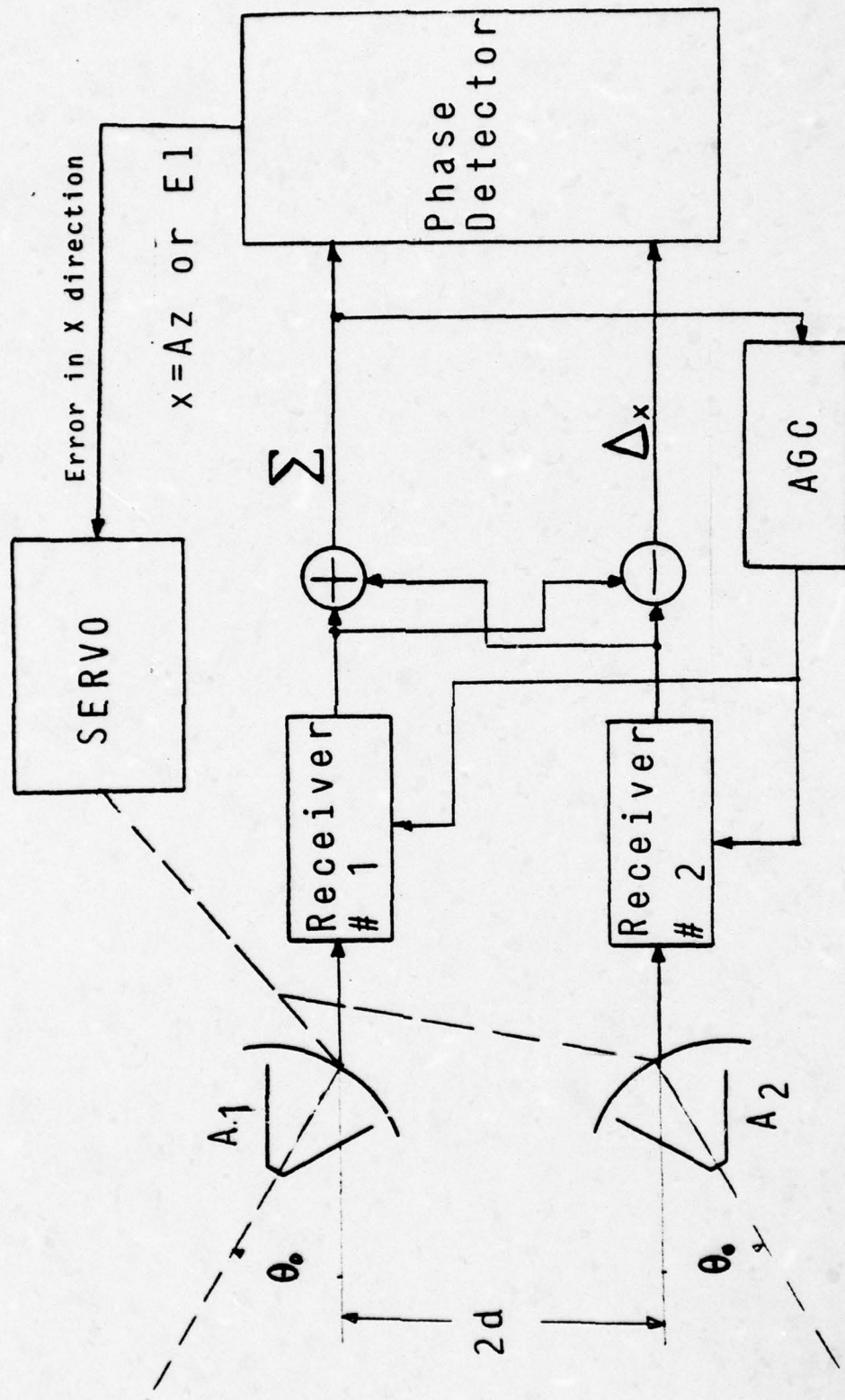

Figure 2.2-4. Block diagram of a general monopulse type (mixed type) for one coordinate.

and then the sum ( $\Sigma$ ) and the difference ( $\Delta$ ) are forming.

Thus we can write the following cos term of  $\omega_{IF}$ :

$$\begin{aligned} \Sigma(\theta_T, t) = S_1 + S_2 = K_{\Sigma} S_O [G_1(\theta_T) \cos(\omega_{IF} t + \phi) \\ + G_2(\theta_T) \cos(\omega_{IF} t - \phi)] \end{aligned} \quad (2.2-9)$$

$$\begin{aligned} \Delta(\theta_T, t) = S_1 - S_2 = K_{\Delta} S_O [G_1(\theta_T) \cos(\omega_{IF} t + \phi - \psi_O) \\ - G_2(\theta_T) \cos(\omega_{IF} t - \phi - \psi_O)] \end{aligned}$$

where:

- $\theta_T$  = Target's position.
- $\theta_O$  = Fixed antenna offset angle.
- $K_{\Sigma}, K_{\Delta}$  = Gains of sum and difference channels respectively.
- $S_O$  = The average constant signal in the sum channel determined by the AGC.
- $\psi_O$  = The phase shift between the sum channel and the difference channel caused by the circuits.
- $\phi$  = The phase shift in antenna  $A_1$  and  $A_2$  caused by the displacement of target by angle  $\theta_T$  relative to the bore sight

direction (see Fig. 2.2-5), and is given by:

$S_1, S_2$  = the I.F. signals within a single radar return.

$$R_1 = R + d \sin \theta_T$$

$$R_2 = R - d \sin \theta_T \quad (2.2-10)$$

$$\phi = \frac{2\pi}{\lambda}(R_1 - R_2) = \frac{4\pi d}{\lambda} \sin \theta_T$$

$2d$  = Distance between phase centers of antenna  $A_1$  and  $A_2$  (see Fig. 2.2-5).

$G_1, G_2$  = Radiation patterns of antenna  $A_1$  and  $A_2$  respectively; for most of the cases they have the same shape only shifted, so we can write:

$$G_1(\theta) = G(\theta_0 - \theta) \quad (2.2-11)$$

$$G_2(\theta) = G(\theta_0 + \theta)$$

where  $G$  is a standardized radiation pattern, and  $\theta$  is an arbitrary direction.

Let us assume that the gains in the sum and the difference are the same (not a necessary condition):

$$K_{\Sigma} = K_{\Delta} = K \quad (2.2-12)$$

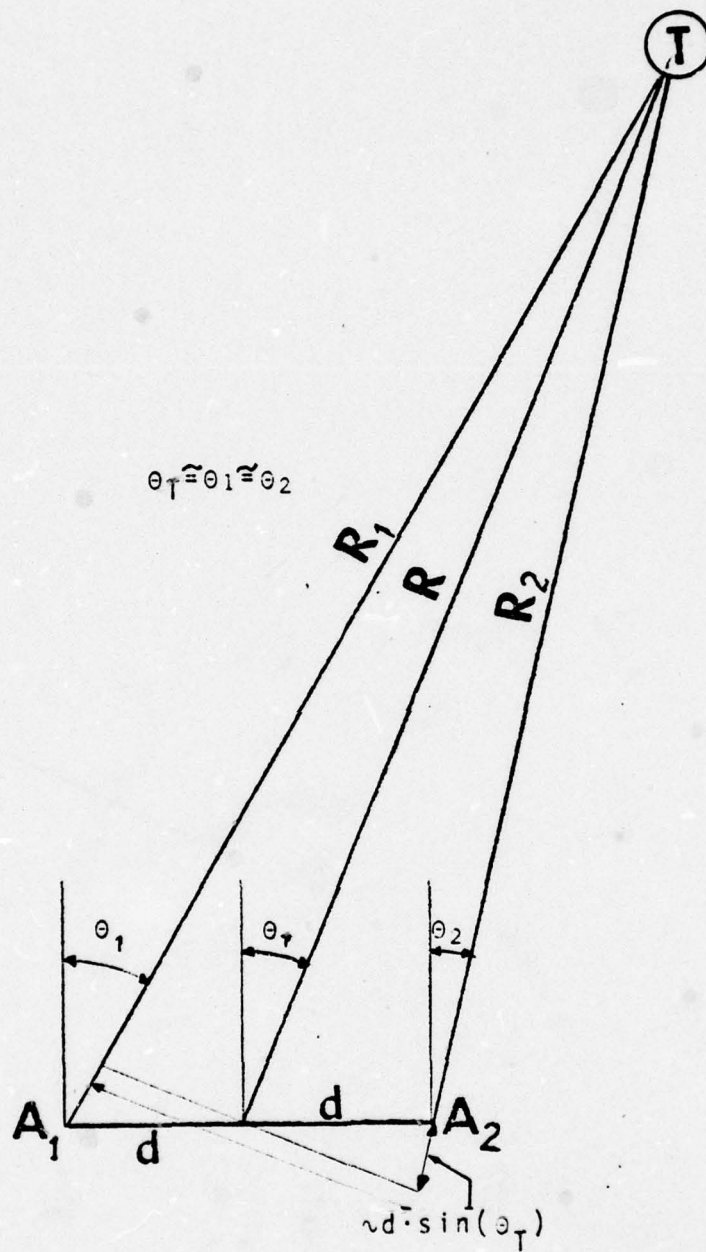

Figure 2.2-5. Wavefront relationships.

By means of the AGC we fix the average sum channel to remain constant, as in C.S., we can assume that after the AGC we have:

$$K \cdot S_o = \text{constant} \quad (2.2-13)$$

Thus, for any level of signal we will have the same output error characteristics. After the phase detector we have an output which is the average of the multiple signal ( $\sum \cdot \Delta$ ). It is shown later on that this quantity is proportional to the error between the direction of the target relative to the antenna.

$$\begin{aligned} \text{error } (\theta_T) &= K' \cdot \text{Average} \{ \sum (\theta_T, t) \cdot \Delta(\theta_T, t) \} \\ &= \alpha' [G^2(\theta_o - \theta_T) - G^2(\theta_o + \theta_T)] \cos \psi_o \quad (2.2-14) \\ &\quad + [2\alpha G(\theta_o - \theta_T) \cdot G(\theta_o + \theta_T) \sin 2\phi] \sin \psi_o \end{aligned}$$

where:

$K'$  is a constant determined by the AGC.

$\alpha'$  is a known constant.

From the last equation we can see that the error is only a function of  $\theta_T$  and equals the deviation from the bore sight (the rest are known constants determined only by the system and not by the target). So from

Eq. 2.2-14 one can determine  $\theta_T$ . To simplify the computations, we can choose the parameters  $\psi_0$ ,  $d$  and  $\theta_0$ . In the two major types of monopulses, we choose these parameters:

(i) Amplitude comparison monopulse:

Choose  $\psi_0 = 0$  or  $d = 0$ . Practically, we choose both of them equal to zero. We would get, for the case  $\psi_0 = 0$  and  $d = 0$ :

$$\text{error}(\theta_T) = [G^2(\theta_0 - \theta_T) - G^2(\theta_0 + \theta_T)] \quad (2.2-15)$$

(ii) Phase comparison monopulse:

Choose  $\psi_0 = \pi/2$ , or  $\theta_0 = 0^*$ . Practically, we choose both. Then, for the case  $\theta_0 = 0$  and  $\psi_0 = \pi/2$ :

$$\begin{aligned} \text{error}(\theta_T) &= 2\alpha G^2(\theta_T) \sin \psi_0 \\ &= 2\alpha G^2(\theta_T) \sin(\gamma \sin \theta_T) \end{aligned} \quad (2.2-16)$$

$$\gamma \triangleq 8\pi d/\lambda$$

From the last equation we see that  $\theta_T$  can be determined. Near the origin ( $\theta_T \rightarrow 0$ ). Then we can assume:

---

\* Assuming  $G(\theta) = G(-\theta)$ .

$$G(\theta_T) \approx G_0 \quad (2.2-17)$$

and

$$\sin(\gamma \cdot \sin \theta_T) \approx \gamma \theta_T$$

so that:

$$\theta_T \approx \beta \cdot \text{error}(\theta_T) \quad (2.2-18)$$

where  $\beta$  = known constant, where the error is the output after the phase detector

$$(\beta = 1/\alpha G_0^2 \gamma).$$

When we wish to determine the position in two coordinates, theoretically we need only the addition of one antenna; practically, four antennas are used. The theory is almost the same; the only difference is that now we have three channels:

- (i) Sum channel =  $\Sigma$
- (ii) Difference channel in AZ =  $\Delta_{AZ}$ .
- (iii) Difference channel in EL =  $\Delta_{EL}$ .

where (refer to Fig. 2.2-6):

$$\Sigma = S_1 + S_2 + S_3 + S_4$$

$$\Delta_{AZ} = (S_1 + S_3) - (S_2 + S_4) \quad (2.2-19)$$

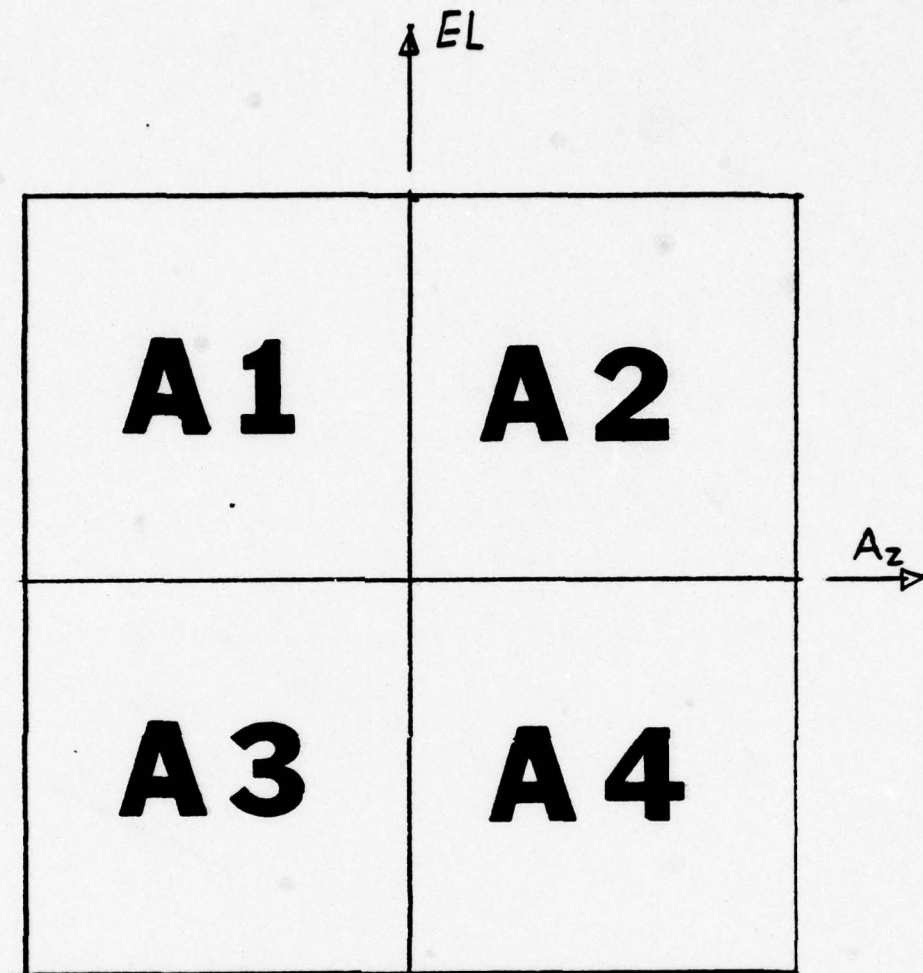

Figure 2.2-6. Relative location of the antennas in two-dimensional monopulse.

$$\Delta_{EL} = (S_1 + S_2) - (S_3 + S_4)$$

and

$S_i$  = the output from antenna i.

## 2. Range Tracking

The most widely used technique for tracking in range is based on two range gates. There are no special techniques as for the method of angle tracking. Information about the range is taken in most of the cases from the sum channel in the monopulse radar and from the incoming pulses in C.S. or L.S. We will briefly cover the principle of automatic range tracking. A block diagram for the range loop tracker is given by Fig. 2.2-7 and the time representations of the signals are given in Fig. 2.2-8. We have two major signals in the loop:

(i) The video pulses -  $S(t)$

They contain information about the range position of the target.

(ii) The range estimate -  $R$ .

The main idea is to open two gates,  $g_1$ ,  $g_2$ , before and after the estimated time of the center of arrival of the pulse ( $t = \frac{2 \cdot R}{c}$ ,  $R$  = target range,  $c$  = velocity of the light). One is the early gate ( $g_1$ ), and the other is the last gate ( $g_2$ ). The portion of the signal contained in the early gate is subtracted from the portion of the signal contained in

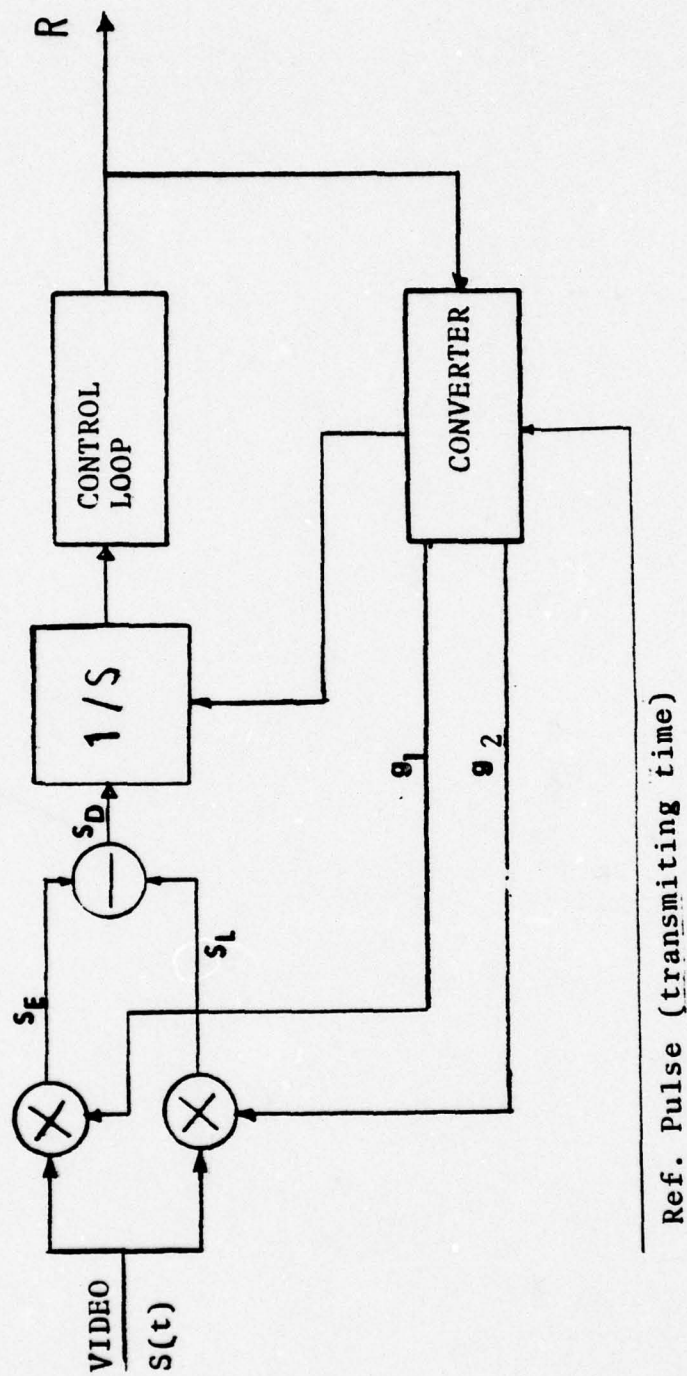

Figure 2.2-7. Block diagram of tracking in range.

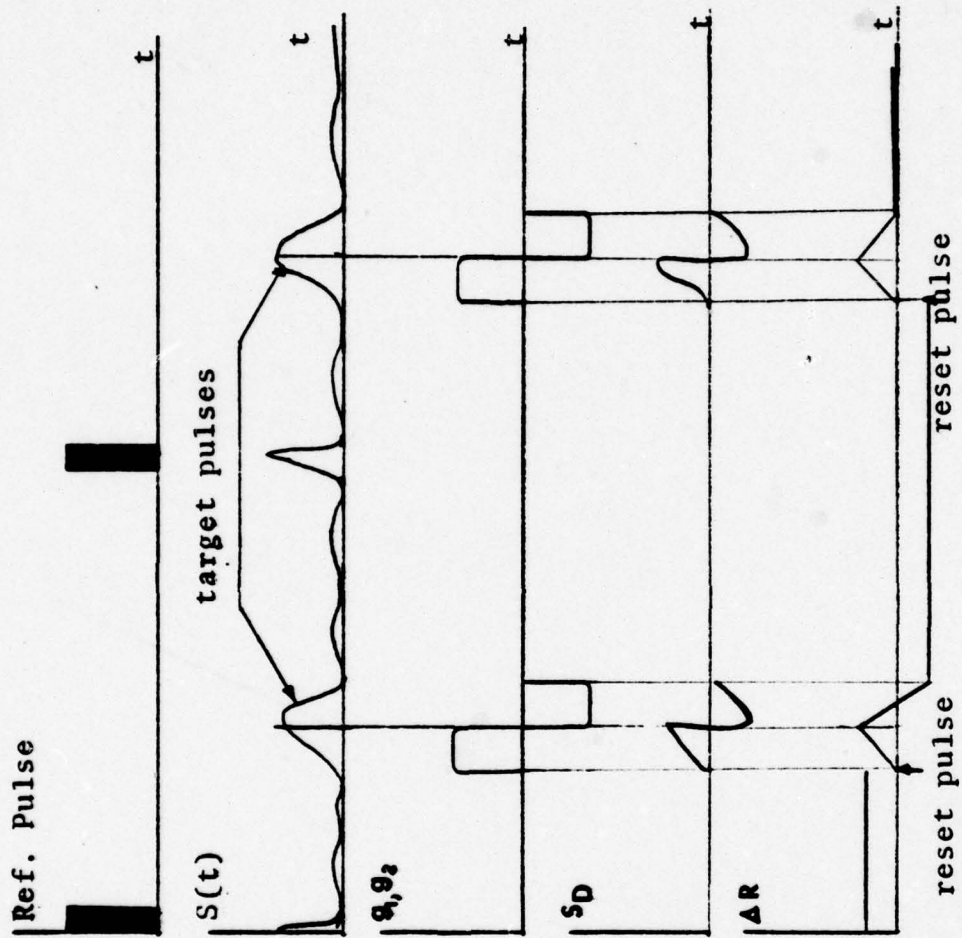

Figure 2.2-8. Time representation of the signals in Fig. 2.2-7.

the late gate after integration. The error is calculated after the end of the late gate. The magnitude of the error signal ( $\Delta R$ ) is a measure of the difference between the center of gravity of the video signal,  $S(t)$ , and the estimated range, which is the center of the two gates. The error is fed into a control system to estimate the range. The output of the control loop is the estimated range,  $R$ . To convert the range into time (to generate the gate's pulse) we use a converter which has the time of the transmitting pulse as a reference input. The outputs of the converter are:

- (i) The two range gates ( $g_1$  and  $g_2$ )
- (ii) A reset pulse to reset the integrator before the range gates.

Because we want to have the same output error,  $\Delta R$ , for all the targets, independent of the target, we must normalize the pulses, and this is done by AGC, which has already been applied in angle tracking.

### III. STATEMENT OF THE PROBLEM

#### A. INTRODUCTION. INTERFERENCE CAUSED BY TWO TARGETS

Let's consider the problem of tracking a target when a false target is in the same resolution cell, i.e.,

$$\frac{\Delta L}{R} < \theta_{3db}$$

$$\Delta R < \Delta t \cdot c/2$$

where:

$\theta_{3db}$  = the beamwidth of the antenna (in radians)

$2\Delta t$  = pulse length

$R$  = range of the target

$\Delta L$  = the difference between the true target and the false target perpendicular to the line of sight of the antenna

$\Delta R$  = the difference between the true target and the false target in range (parallel to the line of sight)

$c$  = the velocity of light.

For simplicity, let's consider the two-dimensional case only (range and elevation). The principle in three dimensions is the same but more complicated, and the results

can be obtained by a straightforward extrapolation of the two-dimensional case. We will consider the case of point targets for developing the theory, but we will implement the results when the targets have complex structure.

#### B. INTERFERENCE IN ANGLE CREATED FROM TWO TARGETS

Consider the case of two point targets (or spheres) in the same resolution cell of the radar with spacing  $\Delta L$  (i.e.,  $\frac{\Delta L}{R} < \theta_{3\text{db}}$ ,  $\Delta R < \frac{c\Delta t}{2}$ ;  $c$  is the velocity of light). As the relative path lengths between the radar antenna and the two sources vary (i.e.,  $R_1$  and  $R_2$ ), the two signals will alternately add and subtract, and so the amplitude and the phase of arrived signal will change. Although such a simple situation (two points targets) may be fictitious, it will illustrate the main behavior. The relative amplitude between the RCS of the two targets is assumed to be a constant "a" and the relative phase difference also constant,  $\alpha$ . The difference in phase is due to difference in range ( $\Delta R$ ) or to reflecting properties. The relative angular error ( $\Delta\theta/\theta_D$ ) is given by [23]:

$$\frac{\Delta\theta}{\theta_D} = \frac{a^2 + a \cos \alpha}{1 + a^2 + 2a \cos \alpha} \quad (3.2-1)$$

The position of the stronger target corresponds to  $\Delta\theta = 0$ , while the smaller target position is at  $\Delta\theta/\theta_D = 1$ . (See Fig. 3.2-1.) The position of the tracking system depends

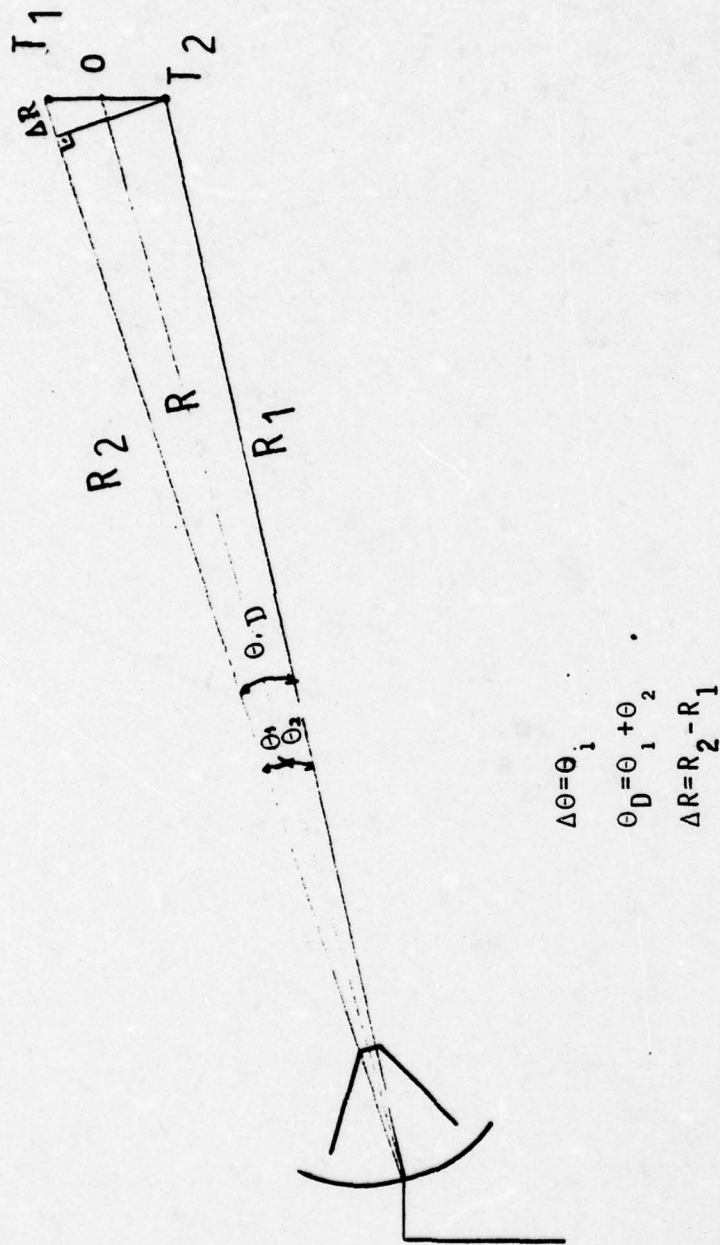

Figure 3.2-1. The geometric representation of the problem.

on the relative phase  $\alpha$  and the ratio  $a$ . One can show that for  $0 \leq a \leq 1$  and  $0 \leq \alpha \leq 2\pi$  - the values of  $\Delta\theta/\Delta\theta_D$  will be between

$$-\infty < \frac{\Delta\theta}{\theta_D} \leq 0.5 \quad (3.2-1)$$

When the echo signals are in phase ( $\alpha = 0$ ), the error reduces to  $\frac{a}{a+1}$ , which corresponds to the so-called "center of gravity" of the two targets.

Now, when we have a complex target, i.e., the ratio  $a$  is a random variable which changes from pulse to pulse. Also  $\alpha$  is random variable which changes from pulse to pulse. Taking these into the given servo loop of the radar system, one can compute the statistics of the random variable  $\Delta\theta$ , and this can give us a good approximation of the error (for example, mean and variance) caused by the addition of two targets in the same resolution cell. However, the simple case results are sufficient for our problem, i.e., to show that the result of two target returns in the same resolution cell causes an error in the estimation of the position of the true target which depends on the signal ratio between the two targets. When the two targets have a complex structure rather than a point, the results are much more complicated and we have to take into account the circuits involved and the statistics of the target's returns.

### C. INTERFERENCE IN RANGE CAUSED BY TWO TARGETS

In range measurements we have a similar effect, called glint, i.e., we will get an error range depending on the difference of range between the targets and the phase difference. We can write the measured error in range as:

$$\Delta R = K \left[ \int_{t_0 - \Delta\tau}^{t_0} S(t) dt - \int_{t_0}^{t_0 + \Delta\tau} S(t) dt \right] \quad (3.3-1)$$

where

$$S(t) = S_1(t) + S_2(t)$$

$$2\Delta\tau = \text{the width of the range gate}$$

$$t_0 = \text{the estimated range of the target (i.e., the position of the range gate).}$$

The behavior in range is strongly influenced by the radar parameters and the circuits used for measurements (for example,  $\Delta\tau$ ), but a "good" estimation of the behavior can be taken as when the two targets are totally in the range gate (i.e., the two targets are very close in range, or there is a large range gate compared to  $\Delta t$ ), so that the range gate will be at the central gravity of the two targets. Also we will assume that the video pulses are rectangular. Refer to Fig. 3.2-1; the center of gravity of the two pulses will be:

$$T_{cg} = \frac{\Delta}{[t]} \int t s(t) dt / \int s(t) dt$$

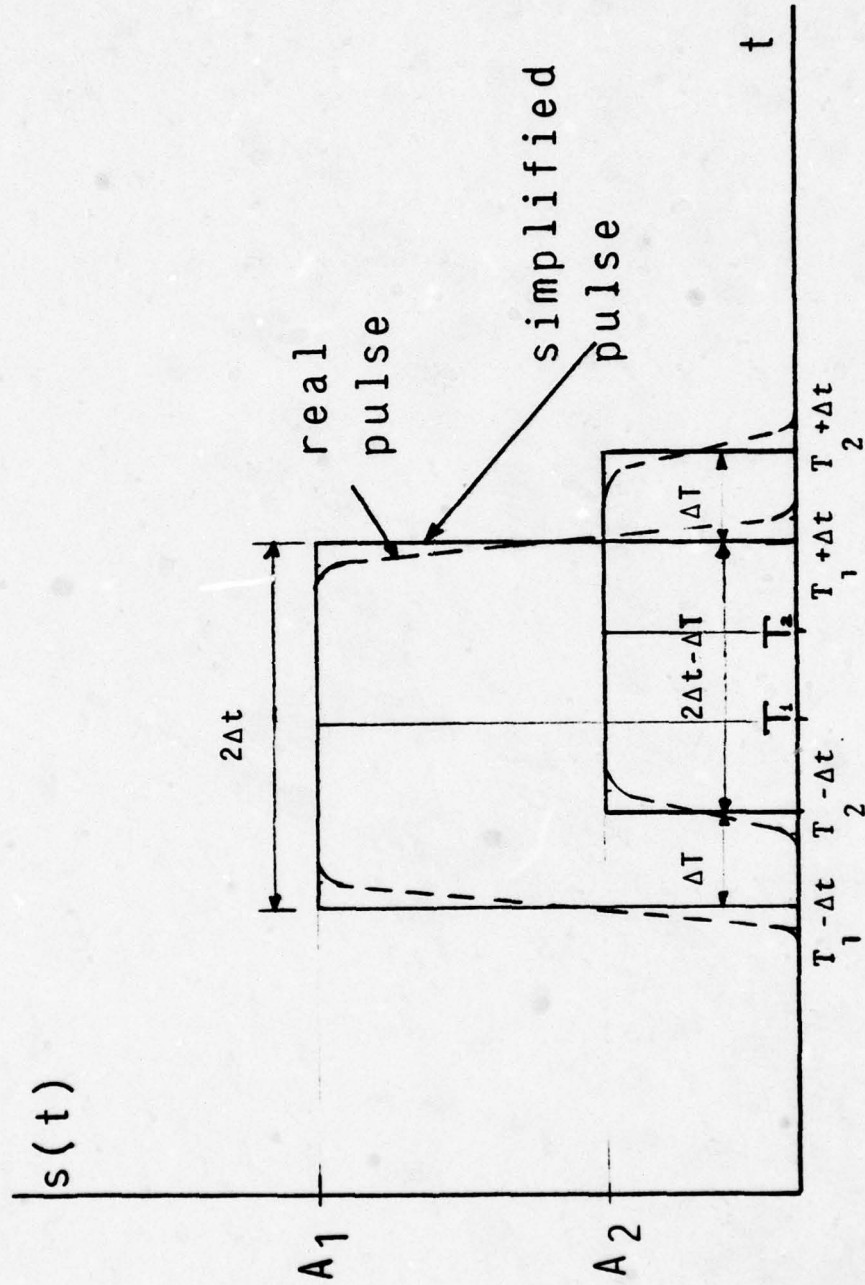
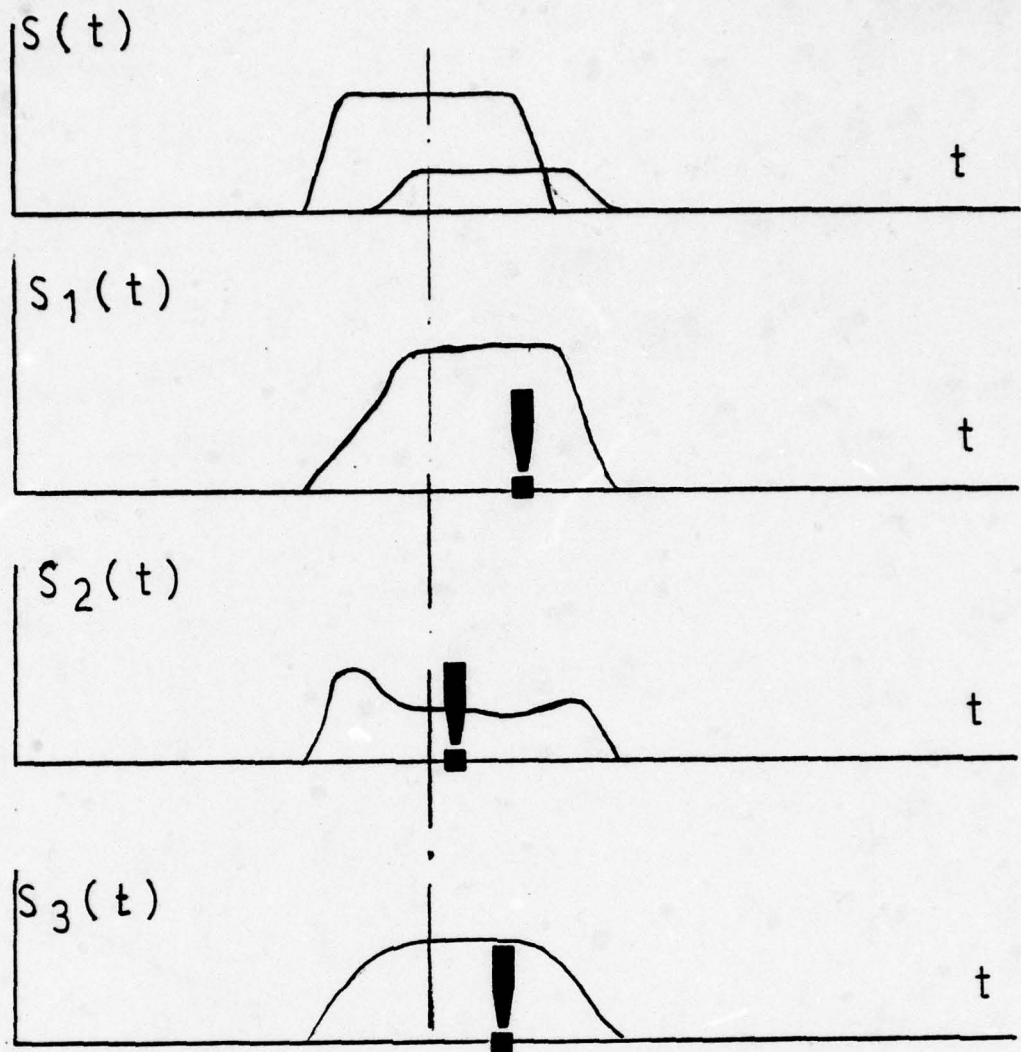

Figure 3.2-1-1. Simplified time representation of the two pulses.



$S$  = Amplitudes of the two signals, separately.

$S_1$  = The two signals combined in phase.

$S_2$  = The two signals for combined out of phase.

$S_3$  = Received signals for the general case.

— · — · — · — · The center of gravity of the target.

■ The center of gravity of the two combined pulses.

Figure 3.2-2. Range errors caused by two targets.

$$T_{cg} = \frac{1}{B} \left\{ \left[ \frac{T_1 + T_2 - 2\Delta t}{2} \int_{T_1 - \Delta t}^{T_2 - \Delta t} s(t) dt \right] + \left[ \frac{T_1 + T_2}{2} \int_{T_2 - \Delta t}^{T_1 + \Delta t} s(t) dt \right] + \left[ \frac{T_1 + T_2 + 2\Delta t}{2} \int_{T_1 + \Delta t}^{T_2 + \Delta t} s(t) dt \right] \right\} \quad (3.3-3)$$

where in case of  $T_1 < T_2$ ; and  $2\Delta t - \Delta T > 0$ ;

$$s(t) = \begin{cases} 0 & ; t < T_1 - \Delta t \\ a_1 & ; T_1 - \Delta t < t < T_2 - \Delta t \\ a^* & ; T_2 - \Delta t < t < T_1 + \Delta t \\ a_2 & ; T_1 + \Delta t < t < T_2 + \Delta t \\ 0 & ; t > T_2 + \Delta t \end{cases}$$

$$B \triangleq \int_{T_1 - \Delta t}^{T_2 + \Delta t} s(t) dt$$

$$a^* = |a_1 + a_2 e^{j\alpha}|$$

$\alpha$  is the relative phase between the two returned pulses.

In general  $T_{cg} \neq T_1$  where  $T_1$  is the position of the true target. Thus we get an error in the computed range. This error is between the two extremes given by the cases when the two pulses are combined in phase and out of phase. When the two pulses are combined in phase we get a simple expression for (3.3-3):

$$T_{cgs} = \frac{a_1 T_1 + a_2 T_2}{a_1 + a_2} \neq T_1 \quad (3.3-4)$$

The error due to the addition of the second target is given by (for the case that they are in phase):

$$\Delta R_s \triangleq T_1 - T_{cgs} = \frac{a_2}{a_1 + a_2} (T_1 - T_2) \quad (3.3-5)$$

which is not equal to zero when  $T_1 \neq T_2$ .

#### D. CONCLUSION

In the last two paragraphs we have shown that when there is an additional target in the resolution cell, the radar will not track on either of the targets, but on their center of gravity. In order to eliminate this phenomena, we must change the design of the radar so that it will track on the two targets.

There are two main ways for accomplishing this objective which have been developed in this study.

- (i) Extract information of the location of the target by processing the signal after the receiver. This leads to the implementation of what we have called the probability filter (Chapter V).
- (ii) Modify the receiver and the filtering process after the receiver in order to extract the information of the two targets.

This leads to an antenna modification and a new type of modified Kalman Filter (Chapter IV). We will consider later

the case of a ship as the true target and chaff as the false target. This implies very small Doppler shift between the two targets. In the problem of air targets the difference in velocity between the target and the chaff is distinguishable and they can be separated easily by a moving target indicator (MTI). In summary, the following techniques are presented in this dissertation:

- (1) Antenna modification plus a Modified Kalman Filter (M.K.F). In this case the location of the targets are resolved on a pulse to pulse basis (see Chapter IV-A). Thus it can include the case of air targets where doppler shift is not applicable rather than be restricted only on surface targets.
- (2) Probability filter. This solution is suggested in case of C.S. or L.S. radars. Here the location of the targets cannot be resolved on a pulse to pulse basis (see chapter II), and many pulses must be used in order to solve the problem. Because the dynamic of a surface target is slow, we can assume a stationary process for the target's RCS. Thus a time average over a small interval can used as a good estimate for the mean of a function of the RCS.

V. A MODIFIED ANTENNA AND KALMAN FILTER SOLUTION FOR UNRESOLVED TARGETS - FOR A MONOPULSE SYSTEM

A. THE THEORETICAL SOLUTION

1. Introduction

The problem of two targets in the same resolution cell is discussed in the literature, mostly from the point of view of resolution and multipath [Refs. 12,13,14,15,16, 17, 18, 19, 20]. The principles involved in the multipath problem are similar to the two-target problem, and it is proposed that they be adopted for this case. The major difference between the two problems is that in the multipath problem the amplitude ratio and the relative phase between the two return signals are known. This information is missing in the two-target problem. The method used to solve the multipath problem is called the "Complex Angle" method (CA). In this chapter we resolve in a new way the positions of the targets in a single pulse and demonstrate how to filter the data. We break the problem into two parts:

- a. Resolve the positions of the targets and their amplitudes, assuming that there is no noise. This gives us the positions of the targets plus estimation noise.
- b. Filtering the positions of the targets. Since the foregoing yields the position of the target plus estimation noise, an additional filter must be used.

Furthermore, the estimate of the positions is without the decision of target vs chaff. Thus this filter must select the two positions related to the chaff and the target.

The general assumption is that in the input to the antenna there is a white Gaussian noise. Since the first block includes a non-linear transformation of the signal (see fig. 4.1-1), there is non-Gaussian noise at the output. This output is the input to the filtering block. Our filtering procedure is complicated even with the assumption of a Gaussian process. Thus, to save a lot of computation, the assumption is made (similar to the usual monopulse analysis), that all the variables are Gaussian. In regular monopulse systems the measurement process requires multiplication  $\Delta \sum$  (see II.B). The variables  $\Delta$  and  $\sum$  are assumed to be Gaussian. Hence the measured error is not a Gaussian variable although in most of the regular monopulse radar,  $\Delta \sum$  is assumed to be Gaussian variable. The same type of assumption is made in this application.

The block diagram is given in Fig. 4.1-1. We start with the first block, i.e., the resolving procedure.

## 2. Resolving Targets with Monopulse System

This paragraph introduces a new technique for resolving two targets, based on the "complex angle" method. The uniqueness of this solution is that we use only a four element antenna, which is the regular monopulse. However

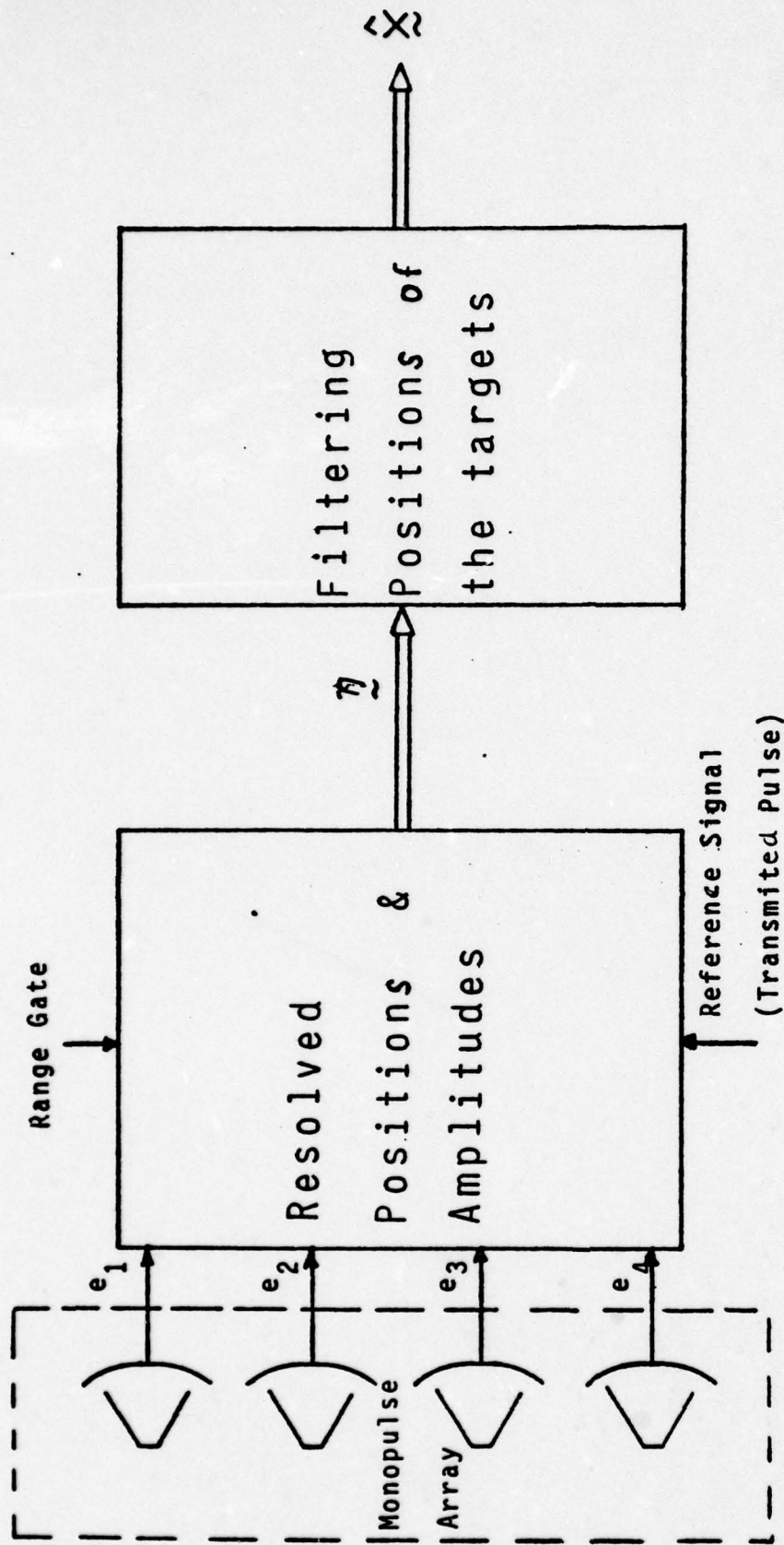

- $\eta$  - The resolved positions of the targets and the amplitudes of the targets.
- $\hat{X}$  - The estimated positions of the target (depending on the information needed it can be other state estimate, i.e., position of the chaff, velocities, etc).

Figure 4.1-1. Block Diagram for estimating the positions of the targets.

we require four output channels from the antenna rather than three channels as in regular monopulse. The resolved positions, similar to regular monopulse, are made in one pulse.

For monopulse system and two targets, the output of each antenna is:

$$e_i = A_1 G_i(x_1, y_1) + A_2 G_i(x_2, y_2) \quad i = 1, 2, 3, 4 \quad (4.1-1)$$

or, in vector form:

$$\vec{e} = A_1 \vec{G}(X_1) + A_2 \vec{G}(X_2)$$

where

$G_i$  - the voltage pattern of the  $i^{\text{th}}$  received beam

$X_{\alpha}$  - coordinates of target  $\alpha$ :  $(X_{\alpha}, Y_{\alpha}) \quad \alpha = 1, 2$

$A_{\alpha}$  - effective complex voltage due to target  $\alpha$  (normalized to the range), and is given by

$$A_{\alpha} = K \sigma_{\alpha} G_t [X_{\alpha}] \exp\{j[\omega_{d\alpha} t + \theta_{\alpha}]\} \quad (4.1-2)$$

$\omega_{d\alpha}$  = the doppler frequency of target  $\alpha$

$\theta_{\alpha}$  - phase associated with target  $\alpha$

$\sigma_{\alpha}$  - The  $\alpha^{\text{th}}$  target voltage cross-section

$G_t$  - one-way voltage pattern of the transmitted beam

K - normalized factor.

Note: For implementation, it is much simpler to assume  $y_1 = 0$  and then solve the equations. This is reasonable if we deal with surface targets, and so  $y_1 \approx 0$ , and this assumption would simplify our decision procedure. However, the reason that we do not assume  $Y_1 = 0$  is because  $Y_1$  is a random variable with almost zero mean but with variance not equal to zero. For example, a ship is tilted by the waves and the c.g. of the ship is changing with time. Thus, the assumption that  $Y_1 = 0$  can cause an error. Also, the assumption  $Y = 0$  would lead to a special case solution which is not desirable.

There are four unknowns for each target:

- The positions -  $\underline{X}_\alpha = (X_\alpha, Y_\alpha)$
- The amplitudes -  $\underline{A}_\alpha = (\text{Re } A_\alpha, \text{Im } A_\alpha)$

Because eq. 4.1-1 is a complex equation and we have four antenna elements, we have a total of eight equations. After solving (4.1-1), one can use (4.1-2) to solve for  $\sigma_\alpha$  and the angle  $(t \cdot \omega_{d\alpha} + \theta_\alpha)$ . By using at least two different samples, we can also separate  $\omega_{d\alpha}$  from  $\theta_\alpha$  and have the doppler information about the target. The main approach of this section is the solution to (4.1-1). Because this equation is quite complicated, the main idea is:

- (1) Solve it by approximation, using Taylor series [12] as is usually done in regular monopulse analysis.
- (2) Solve the non-linear equation with a starting point given by the first step.

The Taylor series solution for this case follows with the solution given by (4.1-18,19).

Our assumption is that the beam is composed of factors, each related to a particular angular dimension, i.e.:

$$G_i(X) = X_i(x) \cdot Y_i(y), \quad i = 1, 2, 3, 4 \quad (4.1-3)$$

We solve the equations for the unknowns by expanding the gains,  $X_i$  and  $Y_i$  by Taylor series up to first order about the boresight line, i.e.:

$$X_i(X) = \sqrt{g} (1 + \alpha_i X) + 0(X^2) \quad (4.1-4)$$

$$Y_i(Y) = \sqrt{g} (1 + \beta_i Y + 0(Y^2)), \quad i = 1, 2, 3, 4$$

where

$g$  - is the boresight gain

$\alpha_i$  - is the slope of the beam near the boresight line for X direction

$\beta_i$  - is the slope of the beam near the boresight line for Y direction.

From (4.1-3) and (4.1-4) we get:

$$G_i(X) = g(1 + \alpha_i X + \beta_i Y + \alpha_i \beta_i XY) \quad (4.1-5)$$

$$i = 1, 2, 3, 4$$

Equation 4.1-1 can be approximated by:

$$e_i = gA_1(1 + \alpha_i X_1 + \beta_i Y_1 + \alpha_i \beta_i X_1 Y_1) \quad (4.1-6)$$

$$+ gA_2(1 + \alpha_i X_2 + \beta_i Y_2 + \alpha_i \beta_i X_2 Y_2) \quad i = 1, 2, 3, 4$$

Those are four complex N.L. equations. Let us now "linearize" the equations by substituting new variables:

$$Z_1 = A_1 + A_2$$

$$Z_2 = A_1 X_1 + A_2 X_2 \quad (4.1-7)$$

$$Z_3 = A_1 Y_1 + A_2 Y_2$$

$$Z_4 = A_1 X_1 Y_1 + A_2 X_2 Y_2$$

In this case the linear approximation of (4.1-6) is:

$$e_i = (Z_1 + \alpha_i Z_2 + \beta_i Z_3 + \alpha_i \beta_i Z_4) \cdot g, \quad i = 1, 2, 3, 4 \quad (4.1-8)$$

or in short form:

$$\underline{e} = B \cdot \underline{z} \quad (4.1-9)$$

where:

$$\underline{z} \triangleq \begin{bmatrix} z_1 \\ \vdots \\ z_4 \end{bmatrix}$$

$$B \triangleq g \begin{bmatrix} 1 & \alpha_1 & \beta_1 & \alpha_1 \beta_1 \\ \vdots & \vdots & \vdots & \vdots \\ \vdots & \vdots & \vdots & \vdots \\ 1 & \alpha_4 & \beta_4 & \alpha_4 \beta_4 \end{bmatrix} \quad (4.1-9a)$$

We can assume that  $B^{-1}$  exists and so the solution of  $\underline{z}$  is given by:

$$\underline{z} = B^{-1} \underline{e} \quad (4.1-10)$$

From the knowledge of  $\underline{z}$  we have to find the location of the targets ( $\underline{x}$ ), and the amplitudes. By equation 4.1-7 it is easy to determine the amplitudes, given the locations:

$$A_1 = \frac{z_2 y_2 - x_2 z_3}{x_1 y_2 - x_2 y_1} = \frac{z_1 x_2 y_2 - z_4}{x_2 y_2 - x_1 y_1} \quad (4.1-11)$$

$$A_2 = \frac{-z_2 y_1 + z_3 x_1}{x_1 y_2 - x_2 y_1} = \frac{-z_1 x_1 y_1 + z_4}{x_2 y_2 - x_1 y_1}$$

Let's now define new variables ( $\underline{a}^T \triangleq [a_1, a_2, a_3, a_4]$ ):

$$a_1 \triangleq \frac{x_1 x_2 (y_2 - y_1)}{x_2 y_2 - x_1 y_1}$$

$$a_2 \triangleq \frac{x_2 - x_1}{x_2 y_2 - x_1 y_1}$$

$$a_3 \triangleq \frac{y_1 y_2 (x_2 - x_1)}{x_2 y_2 - x_1 y_1}$$

$$a_4 \triangleq \frac{y_2 - y_1}{x_2 y_2 - x_1 y_1}$$

(4.1-12)

This gives us a new linear form of equations 4.1-11:

$$z_1 a_1 + z_4 a_2 = z_2$$

(4.1-13)

$$z_1 a_3 + z_4 a_4 = z_3$$

The last two complex equations (4.1-13) are four equations, and we have to write  $z_i$  as it is the sum of real and imaginary parts.

$$z_i = R_i + j I_i, \quad i = 1, \dots, 4 \quad (4.1-14)$$

Let's define

$$\underline{\tilde{R}} \triangleq \begin{bmatrix} R_1 \\ \vdots \\ R_4 \end{bmatrix}$$

$$\underline{\tilde{I}} \triangleq \begin{bmatrix} I_1 \\ \vdots \\ I_4 \end{bmatrix}$$

where:

$$\underline{\tilde{z}} = \underline{\tilde{R}} + j \underline{\tilde{I}}$$

We now can return to eq. 4.1-13 by defining:

$$\underline{H}_Z \triangleq \begin{bmatrix} R_1 & R_4 & | & \circ \\ I_1 & I_4 & | & \\ \hline \circ & & | & R_1 & R_4 \\ & & | & I_1 & I_4 \end{bmatrix}$$

$$\underline{b}_Z \triangleq \begin{bmatrix} R_2 \\ I_2 \\ R_3 \\ I_3 \end{bmatrix}$$

Then we write equation 4.2-13 in short form:

$$H_Z \cdot \underline{a} = \underline{b}_Z \quad (4.1-15)$$

Solving this equation gives:

$$\underline{a} = H_Z^{-1} \underline{b}_Z = \frac{1}{R_1 I_4 - R_4 I_1} \begin{bmatrix} (R_2 I_4 - R_4 I_2) \\ (-R_2 I_1 + R_1 I_2) \\ (R_3 I_4 - R_4 I_3) \\ (-R_3 I_1 + R_1 I_3) \end{bmatrix} \quad (4.1-16)$$

Assuming  $H_Z^{-1}$  exists, then  $\underline{a}$  is determined. Now we have to solve  $X_1$ . First we notice that:

$$\frac{a_2}{a_4} = \frac{X_2 - X_1}{Y_2 - Y_1}$$

$$\frac{a_1}{a_4} = X_1 X_4 \quad (4.1-17)$$

$$\frac{a_3}{a_2} = Y_1 Y_4$$

$$a_2 = \frac{X_2 - X_1}{X_2 Y_2 - X_1 Y_1}$$

For convenience we define a new variable:

$$\underline{U} = H_u \underline{x}$$

$$\underline{x} \triangleq \begin{bmatrix} x_1 \\ y_1 \\ x_2 \\ y_2 \end{bmatrix}$$

(4.1-18)

$$H_u = \begin{bmatrix} D_1 & | & 0 \\ \hline 0 & | & D_1 \end{bmatrix}$$

$$D_1 \triangleq \begin{bmatrix} -1 & 1 \\ 1 & 1 \end{bmatrix}$$

The inverse transform is given by:

$$\underline{x} = \frac{1}{2} H_u \underline{U} \quad (4.1-19)$$

Solving (4.1-17,18) for  $\underline{U}$  gives, by eliminating  $\underline{x}$ :

$$\underline{U} = \begin{bmatrix} \frac{a_2}{a_4} U_3 \\ \frac{a_1 a_4 - a_3 a_2 + 4}{a_4} \\ S \sqrt{U_4^2 - 4 \frac{a_3}{a_2}} \\ \frac{4 - a_1 a_4 + a_3 a_2}{a_2} \end{bmatrix} \quad (4.1-20)$$

when  $S$  is a variable which can be  $+1$  or  $-1$ . In determining  $\underline{U}$  one solves for  $U_2$  and  $U_4$  first. Using these values one can find  $U_3$  and  $U_1$ . This is illustrated in Fig. 4.1-2.

The variable  $S$  occurs because we have a nonlinear equation. It is easy to see that changing  $S$  from  $+1$  to  $-1$  will cause the whole solution to change indices. (I.e. given  $e$  4.1-10 yields  $\underline{z}$ ,  $\underline{R}$ ,  $\underline{I}$  and  $b_2$ , 4.1-16 yields  $\underline{a}$ , 4.1-10 gives  $\underline{U}$ , 4.1-19 gives  $\underline{X}$ , 4.1-11 gives  $A_1$  and  $A_2$ ; see figure 4.1-2):

When  $S = 1$

$$\underline{X} = \begin{bmatrix} X_1 \\ Y_1 \\ X_2 \\ Y_2 \end{bmatrix}$$

$$\underline{A} = \begin{bmatrix} A_1 \\ A_2 \end{bmatrix}$$

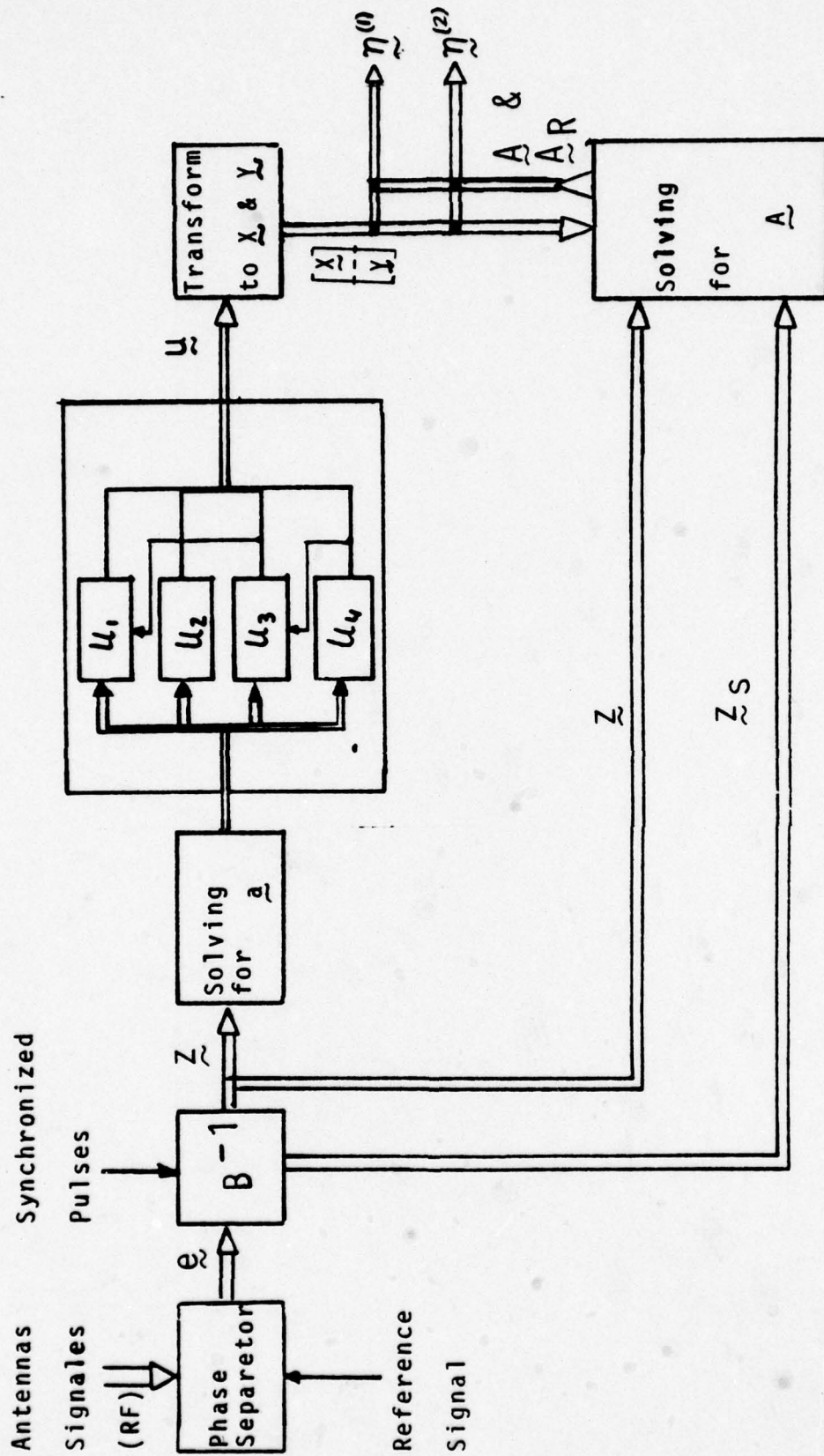

Figure 4.1.-2. Block diagram of determining the amplitudes and the positions of the targets.

or when  $S = -1$

$$\tilde{x} = \begin{bmatrix} x_2 \\ y_2 \\ x_1 \\ y_1 \end{bmatrix}$$

$$\tilde{A} = \begin{bmatrix} A_1 \\ \tilde{A}_1 \\ A_2 \\ \tilde{A}_2 \end{bmatrix}$$

From which it is clear that in both cases we have the solution of the location of the two targets. For the solution ( $\eta$ ) assume an arbitrary that  $S = +1$ .

$$\tilde{\eta} \left| \begin{array}{l} \text{solution} \\ \text{for } S=1 \end{array} \right. \triangleq \begin{bmatrix} \tilde{\eta}^{(1)} \\ \text{---} \\ \tilde{\eta}^{(2)} \end{bmatrix} = \begin{bmatrix} x_1 \\ y_1 \\ \tilde{A}_1 \\ x_2 \\ y_2 \\ \tilde{A}_2 \end{bmatrix}$$

Then we have a unique solution for the positions of the targets but we can't match the position of the target to the measurement. There are two possibilities for target #1 position (and the same for target #2), i.e.: the position of target #1 can be  $\begin{pmatrix} x_1 \\ y_1 \end{pmatrix}$  or  $\begin{pmatrix} x_2 \\ y_2 \end{pmatrix}$ .

The block diagram of solving the positions and the amplitudes of the two targets is given in Fig. 4.1-3. Everything is straightforward in the block diagram except the amplitude vector for the range, which will be explained in the following paragraph.

Solution for Range

As was mentioned in Sec. II.B, the error in range is given by:

$$\Delta R = K_R \frac{V_{eg} - V_{lg}}{V_{eg} + V_{lg}} \quad (4.1-21)$$

where:

$V_{xg}$  - is some measure of the amplitude of the X gate (early or late)

$K_R$  - constant.

In our case we cannot take the amplitude in each range gate and substitute into the formula because at each gate we have the sum of two amplitudes. Thus we have to use the technique developed for resolving the angle. The simplest way is to use the procedure for solving the amplitudes for each target, but now we have to consider two amplitudes for each target (for the early and late gates). The procedure is described in the block diagram 4.1-3.

(1) For solving the regular amplitude we use formula 4.1-11. We need the delay because we need to wait for the solution for X and Y.

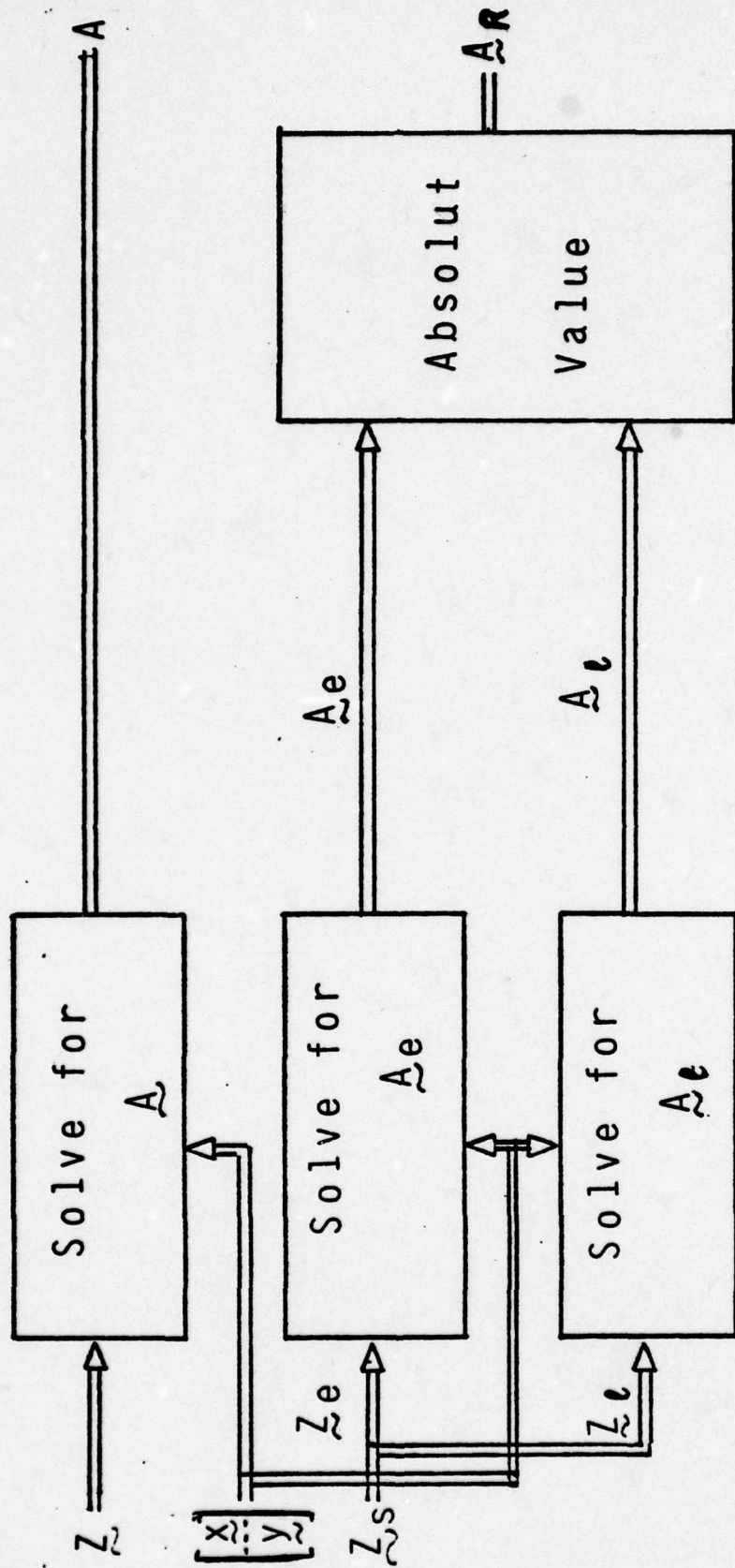

Figure 4.1-3. Block diagram of the amplitudes.

(2) We take (at least) two samples of  $\tilde{z}$  in the late gate and in the early gate ( $z_l, z_e$ ) and we use the same formula for obtaining the amplitudes at each gate, where:

$$\tilde{z}_s \triangleq \begin{bmatrix} z_l \\ - \\ z_e \end{bmatrix}$$

For the purpose of tracking in range we do not need the complex signals. Thus we give the output only for the absolute value of each amplitude.

Note that here we cannot use integration as suggested in Sec. II.B because we have to take a sample of the amplitude. To perform a process like integration we have to take many samples. Our process involves a phase detector plus a computation for each sample, and this limits the samples that we can take. In our case in order to save the amount of computations, only two samples are taken. Furthermore, we can save even more calculations by assuming the range of the target and the chaff to be the same.

After we have the approximate solution for the unknowns, one can substitute these values in eq. 4.1-1 as a first approximation and iterate the N.L. equations for a more accurate solution where we can assume that:

$$U_i(u) = K_i \frac{\sin \xi_i(u - \theta_{oi})}{\xi_i(u - \theta_{oi})}, \quad i = 1, \dots, 4 \quad (4.1-22)$$

with:

$U_i$  - is  $X_i$  or  $Y_i$

$u$  - is the coordinate  $x$  or  $y$

$\xi_i, K_i$  - parameters of antenna  $i$

$\theta_{oi}$  - the offset of antenna  $i$

Let us now observe that this method gives us exactly the same solution for the single target case. In this case,  $A_2 = 0$  and so (4.1-7) reduced to:

$$z_1 = A_1$$

$$z_2 = A_1 X_1$$

(4.1-23)

$$z_3 = A_1 Y_1$$

$$z_4 = A_1 X_1 Y_1$$

And so

$$x_1 = \frac{z_2}{A_1} = \frac{z_2}{z_1}$$

(4.1-24)

$$y_1 = \frac{z_3}{A_1} = \frac{z_3}{z_1}$$

Now, let's assume the same beam shape for all the antennas (i.e.,  $|\alpha_i| = |\beta_i| = \alpha$ ). Then the matrix B becomes (refer to Fig. 2.2-6 and equation (4.1-9a):

$$B = g \cdot \begin{bmatrix} 1 & \alpha & -\alpha & -\alpha^2 \\ 1 & -\alpha & \alpha & -\alpha^2 \\ 1 & -\alpha & -\alpha & \alpha^2 \\ 1 & \alpha & \alpha & \alpha^2 \end{bmatrix} \quad (4.1-25)$$

Solving for  $B^{-1}$ :

$$B^{-1} = \frac{1}{4g\alpha^2} \begin{bmatrix} \alpha^2 & \alpha^2 & \alpha^2 & -\alpha^2 \\ \alpha & \alpha & -\alpha & -\alpha \\ -\alpha & \alpha & -\alpha & \alpha \\ -1 & 1 & 1 & -1 \end{bmatrix} \quad (4.1-26)$$

Now we can solve for  $x_1, y_1$  (4.1-19):

$$x_1 = \frac{1}{\alpha} \frac{(e_2 + e_4) - (e_1 + e_3)}{e_1 + e_2 + e_3 + e_4} = \frac{1}{\alpha} \frac{\Delta x}{L} \quad (4.1-27)$$

$$y_1 = \frac{1}{\alpha} \frac{(e_1 + e_2) - (e_3 + e_4)}{e_1 + e_2 + e_3 + e_4} = \frac{1}{\alpha} \frac{\Delta y}{L}$$

which is the well known solution for regular monopulse systems. Thus, from this result we can say that regular monopulse system is a special case of our development.

### 3. The Filtering Procedure

In the last paragraph we investigated a way to resolve the unresolved targets where we have a monopulse system with phase detector. The development was based on the assumption that we have no noise. We could work this problem as was suggested by [20] but this leads to a lot of computations, and the estimator functions on a pulse to pulse basis ([20] does not use the prior information). Thus, after our estimator we have to use a filter. Furthermore, we have also to make a decision about target vs chaff.

For simplicity we assume that the outputs  $\eta$  (see Fig. 4.1-1) are Gaussian variables, so we must solve two problems:

(1) Selection - i.e., at each pulse we have to distinguish the origin of the measured data, which means that each measurement gives us two sets of data, target and chaff, but we cannot distinguish between the two.

(2) Filtering - After we make the decision, our data is not noise free. Furthermore, the decision may be wrong. For this purpose, we have to filter the data output from the selection block. In the previous analysis we assumed that measurement noise does not exist. In reality we should have started with the equations:

$$e_i = A_1 G_i(x_1) + A_2 G_i(x_2) + n_i \quad i = 1, 2, 3, 4 \quad (4.1-28)$$

where  $n_i$  is a complex white Gaussian noise:

$$n_i = n_{ci} + j n_{si} \quad (4.1-29)$$

$n_{ci}, n_{si}$  - white Gaussian noise with zero mean, each of them with variance  $\sigma^2$ , assuming no correlation between  $n_c$  and  $n_s$ .

However we used (4.1-1) so that after our processing, we can assume that a Gaussian noise is introduced. The computed information needed for Gaussian variances are:

- i) The means
- ii) The variances
- iii) The correlation between the noises.

That is, we have to include, for the random process  $\underline{n}$ :

$$\underline{\mu} = E\{\underline{n}\} \quad (4.1-30)$$

$$\Lambda_{\underline{n}} = \text{COVAR}\{\underline{n}\} \quad (4.1-31)$$

which is straightforward.

Once we have  $\underline{n}$  output of the resolved block positions with the approximated statistics of the noise, we can make our decision and filter using the information about the amplitudes of the signals and the dynamics of the targets. The decision and filtering process is described in the block diagram given in Fig. (4.1-4).

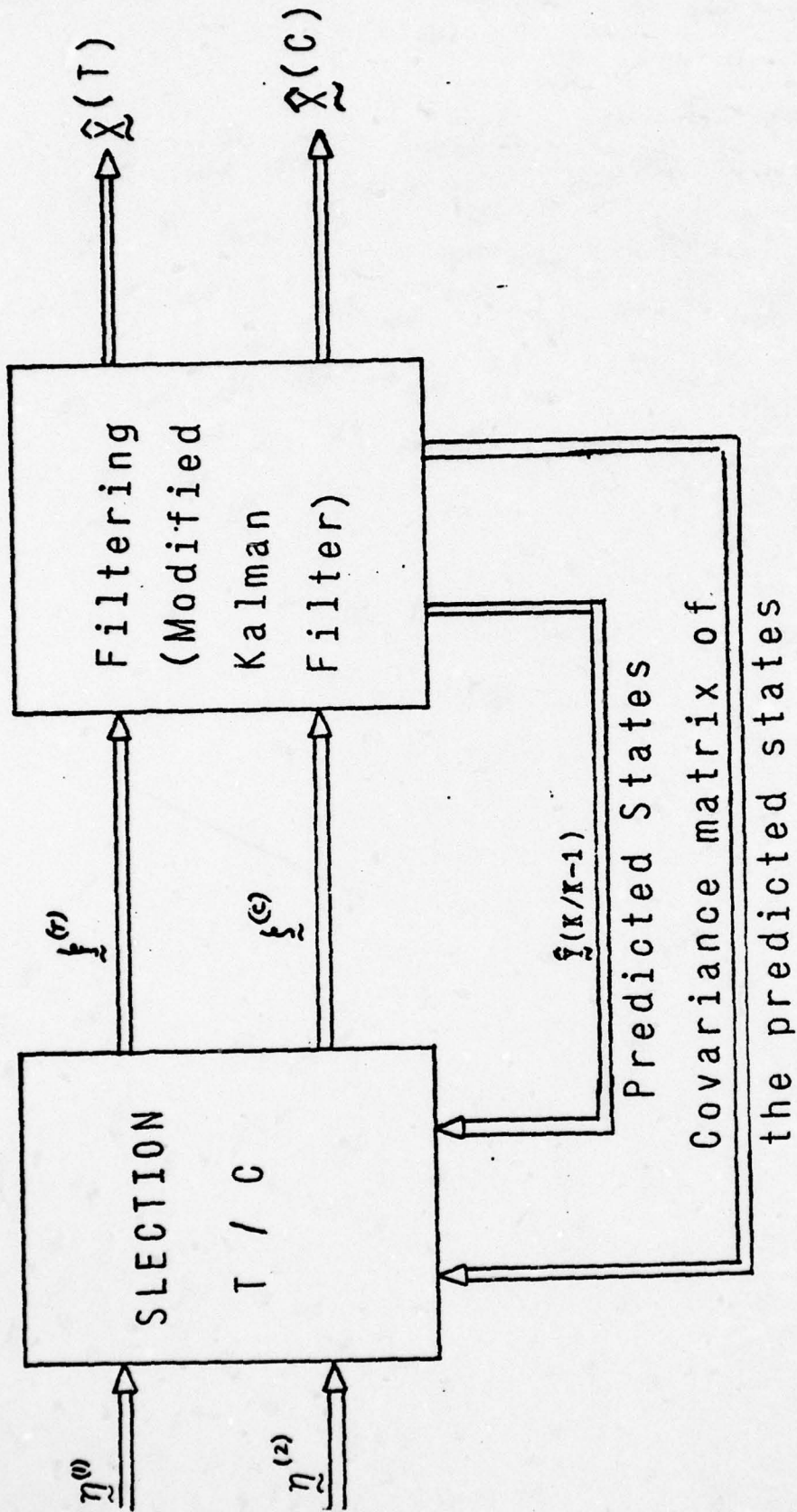

Figure 4.1-4. Block diagram of the decision of target-chaff and filtering.

Our information comes from the monopulse antennas, and we compute the positions and the amplitudes of the targets in the resolving block. The outputs from the resolving block are  $\eta^{(1)}$  and  $\eta^{(2)}$  which include the positions and the amplitudes of targets number one and two, and we have for the filtering procedure to decide if  $\eta^{(1)}$  belongs to the target or the chaff. The information needed to decide is the predicted position of the targets and the covariance matrix of the error of our prediction.

After the selection block, we get the information needed for the filtering, i.e., the amplitudes and the positions of the target and the chaff. The output of the filtering block is the estimated position of the target and may be, if needed, the position of the chaff and the velocities.

There is also an outside output to the filtering block, i.e., during the process we change the position of the antenna in order to zero in on the target. Because our model refers to the absolute coordinate we have to take the change of the relative position antenna-target into account. In our case we make the above assumption for simplicity:

- i) The process is sequential. This means that we calculate the estimator output and the covariance matrix from pulse to pulse. We do not have to store all the measured information so far. This assumption comes from the desire for a simple procedure

and reduces the amount of storage and computation needed for a non-sequential process.

ii) Our variables are Gaussian.

The theory of the selection and filtering is given in Appendix A. We give here a short description of the procedure.

i) The dynamic model:

$$\underline{\tilde{x}}(K+1) = \Phi \underline{\tilde{x}}(K) + \Delta \underline{u}(K) + \underline{w}(K)$$

$$\underline{\tilde{x}}(K) \triangleq \begin{bmatrix} \underline{\tilde{x}}^{(T)}(K) \\ \text{-----} \\ \underline{\tilde{x}}^{(C)}(K) \end{bmatrix} \quad \begin{array}{l} = \text{the amplitudes, (4.1-32)} \\ A_{\alpha} \text{ and the} \\ \text{positions of} \\ \text{the targets,} \\ \underline{x}_{\alpha} \end{array}$$

$$\Phi = \begin{bmatrix} \Phi^{(T)} & | & 0 \\ \text{-----} & & \text{-----} \\ 0 & | & \Phi^{(C)} \end{bmatrix}$$

$\Phi^{(i)}$  = the transition matrix of each target (i=T or i=C)

$$\Delta \triangleq \begin{bmatrix} \Delta^{(T)} \\ \text{-----} \\ \Delta^{(C)} \end{bmatrix}$$

ii) The measure model:

$$\underline{\eta}(K) = L(K) \cdot C \cdot \underline{X}(K) + \underline{V}(K)$$

$$C = [C^{(T)} \mid C^{(C)}]$$

$$\underline{\eta}(K) \triangleq \begin{bmatrix} \underline{\eta}^{(1)}(K) \\ \text{-----} \\ \underline{\eta}^{(2)}(C) \end{bmatrix}$$

$L(K)$  - is the random switching matrix  
(see eq. A-1).

iii) The statistical information about the states and the noise is given in Appendix A.

a. The Selection Procedure. All the procedure is described in Appendix A. Hence only the block diagram is given here (4.1-5).

Description: We have in this block the above inputs:

- i) The resolved information about the targets -  $\underline{\eta}(K)$
- ii) The estimate predicted positions and amplitudes of the targets -  $\hat{\underline{y}}(K|K-1)$
- iii) The covariance matrix of the error of the estimate prediction -  $\Lambda$ .

The output from this block is the assumed information about the target. The resolved information of the target is transferred into two forms:

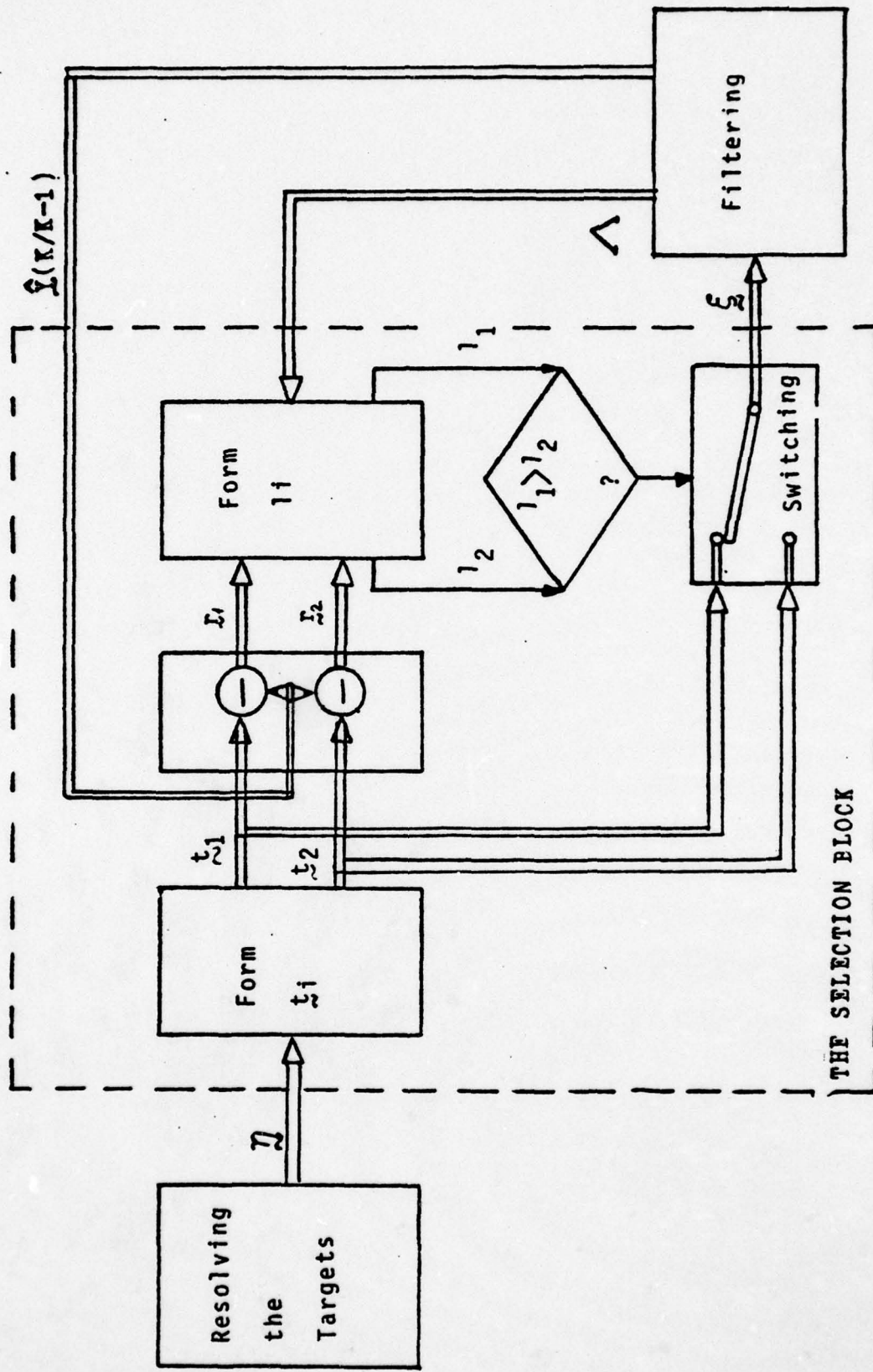

Figure 4.1-5. Block diagram of the selection procedure.

$$i) \quad \underline{t}_1 = \begin{bmatrix} \underline{\eta}^{(1)} \\ \text{----} \\ \underline{\eta}^{(2)} \end{bmatrix} \quad \text{which is the original input.}$$

$$ii) \quad \underline{t}_2 = \begin{bmatrix} \underline{\eta}^{(2)} \\ \text{----} \\ \underline{\eta}^{(1)} \end{bmatrix} \quad \text{which is the switched input.}$$

After we form the two possibilities  $\underline{t}_i$ , we subtract the predicted measure  $\hat{Y}(K|K-1)$  with the formed  $\underline{t}_i$  and we get a two error vector  $\underline{r}_i$ . We now form the likelihood test, and we decide  $\underline{t}_1$  or  $\underline{t}_2$  according to  $l_1 > l_2$  or  $l_2 < l_1$ . The output from this block is the assumed information about the target.

b. Filtering.

After the decision about target vs chaff is made, we have to filter the output from the selection block (4.1-5). The filtering could be straightforward if we have high confidence that our selection is correct. In our case we are not sure if our selection is correct, and we must take this into account. Since we cannot tell if our selection was correct or not, we can only take into account the probability that the selection was correct, i.e., we cannot reject or accept the data, we can only "weight" the data depending on the computed probability that our data is correct or not.

The two possibilities are:

- i) A true data available, i.e., we decide the right selection.
- ii) A false data available, i.e., we decide the wrong selection.

We must assign a certain "weight" (depending on the probability that this data is true) to the data. Because all the procedure is described in Appendix A, only the block diagram is given here, (Fig. 4.1-6).

## B. SIMULATION OF THE MODIFIED KALMAN FILTER

### 1. Introduction

The M.K.F. is very important in our system, and we must show that the concept of the modified filter works. We will use only one component of measurement to show how it performs. Because the most distinguishable component between the chaff and the target is in the height, the simulation is only for height. To take into account the variance and the bias of the estimation error the probability of missing is used as a criterion. The probability of missing includes both the bias and the variance of the estimation error. Furthermore the radar system is assumed to be in a missile.

We have chosen only one component of measuring, i.e., the height. The target, which is assumed to be on the surface, has zero net velocity in this direction. The chaff has no negative velocity in height. Thus we can define, according to (4.1-32):

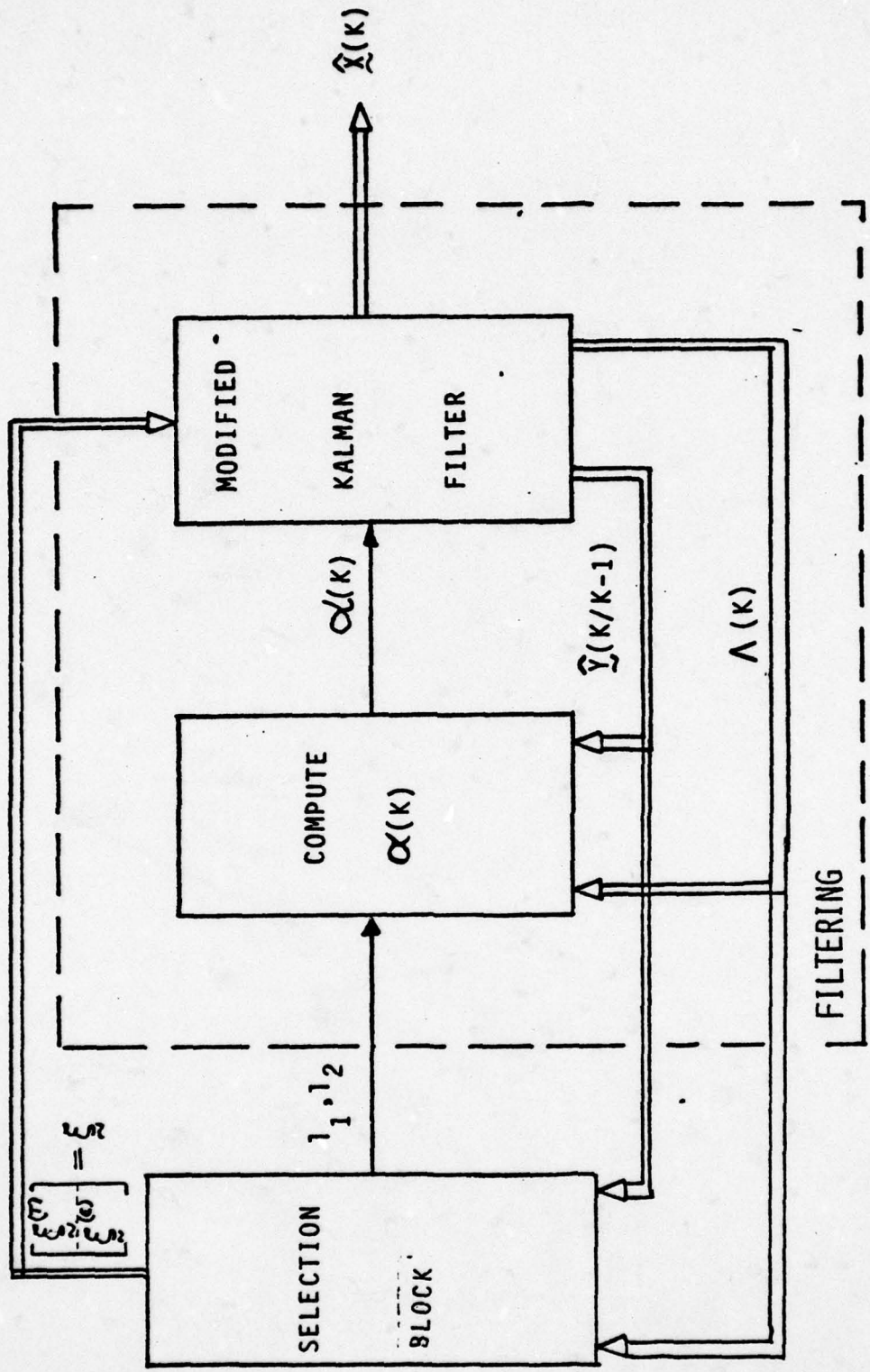

Figure 4.1-6. The block diagram of the filtering procedure.

$$\underline{\tilde{x}}(K) \triangleq \begin{bmatrix} x_1(K) \\ x_2(K) \\ x_3(K) \end{bmatrix} \triangleq \begin{bmatrix} x^{(T)}(K) \\ \text{-----} \\ x_1^{(C)}(K) \\ x_2^{(C)}(K) \end{bmatrix} \triangleq \begin{bmatrix} x^{(T)}(K) \\ \text{-----} \\ \underline{\tilde{x}}^{(C)}(K) \end{bmatrix} \quad (4.2-1)$$

where:

$x_1(K) = x^{(T)}(K)$  - is the height of the target at time K

$x_2(K) = x_1^{(C)}(K)$  - is the height of the chaff at time K

$x_3(K) = x_2^{(C)}(K)$  - is the velocity of the chaff at time K

and

$$\Delta = 0.$$

According to the above assumptions, we can relate (4.1-32), (A-2) and (A-2a) with the proper matrices. The matrices are changed according to the simulations performed.

Note: In the simulation we use the terms (refer to (4.1-32)):

- "without switching" which means

$$L(K) \equiv I \text{ for all } K's$$

- "with switching" which means that  $L(K)$  is as defined in (A-1b).

In the simulations we compare the M.K.F. "with switching" to the R.K.F. "without switching" as a reference (ideal), and to the R.K.F. "with switching" to show the improvement that we get.

A Monte Carlo simulation with 200 ensemble members is performed. The results are given in comparison to the regular Kalman Filter (R.K.F.) (where there is no switching in the input). The criterion for missing is as follows:

- The missile is simulated as an inertial mass and it is guided to reach the estimated height of the target, i.e.:

$$x_M(i+1) = Kx_M(i) + (1-K)\hat{x}^{(T)}(i+1) \quad (4.2-2)$$

where

$x_M(i)$  - the missile's position at time  $i$

$\hat{x}^{(T)}(i)$  - the estimation of the height at time  $i$ , see (4.2-1)

$K$  - transition constant of the missile. It is chosen to be 0.8.

- The criterion of missing:

$$|x_M(\text{TTG}) - x^{(T)}(\text{TTG})| \leq \beta \quad \beta \geq 0$$

where:

- TTG - time to go (chosen to be 40 sec)  
 $x^{(T)}(i)$  - the height of the target at time  $i$ , see (4.2-1).

In our case  $\beta$  is chosen to be 0.75 which experimentally gives a probability of missing of about 0.5.

We study the performance of the two filters by changing three significant parameters:

- variance of the noise.
- mean of the initial states.
- standard deviation of the initial position of the chaff, i.e.:

$$\sqrt{E\{[\bar{X}_2(0) - x_2(0)]^2\}}$$

Note: In the simulation instead of the formula (A-13) for  $\alpha(K)$  the following formula was used; by mistake:

$$\alpha(K) = \frac{1}{1 + \gamma(K-1)\beta(K)}$$

where:

$$\gamma(K-1) = \rho^{-L/2}$$

$$L \triangleq b^T(K) \Lambda^{-1}(K) b(K)$$

$$b^T(K) \triangleq \begin{bmatrix} \hat{X}_1(K|K-1) - \hat{X}_2(K|K-1) \\ \hat{X}_2(K|K-1) - \hat{X}_1(K|K-1) \end{bmatrix}$$

and  $\beta(K)$  is the same as  $\beta(K)$  given in (A-13a), and  $\Lambda^{-1}(K)$  is defined in (A-6). This leads to an  $\alpha(K)$  slightly higher than the real  $\alpha(K)$ . Apparently this

change in  $\alpha(K)$  will not affect the simulation results significantly. Hence it should not change the simulation conclusion.

## 2. Simulation Results

### a. Influence of the noise on the Performance of the Filter

The following parameters and matrices are chosen:

$$\Phi = \begin{bmatrix} 1 & 0 & 0 \\ 0 & 1 & 1 \\ 0 & 0 & 1 \end{bmatrix}$$

$$C = \begin{bmatrix} 1 & 0 & 0 \\ 0 & 1 & 0 \end{bmatrix}$$

$$R = \begin{bmatrix} 1 & 0 \\ 0 & 1 \end{bmatrix}$$

$$M = \begin{bmatrix} 50 & 0 & 0 \\ 0 & 5000 & 0 \\ 0 & 0 & 0.5 \end{bmatrix}$$

$$\bar{X}(0) = \begin{bmatrix} 10 \\ 100 \\ -1 \end{bmatrix}$$

$$Q = \begin{bmatrix} a & 0 & 0 \\ 0 & a/100 & 0 \\ 0 & 0 & a/4 \end{bmatrix}$$

where

"a" - is a parameter to be changed. "a" is changed from 0.1 to 100.

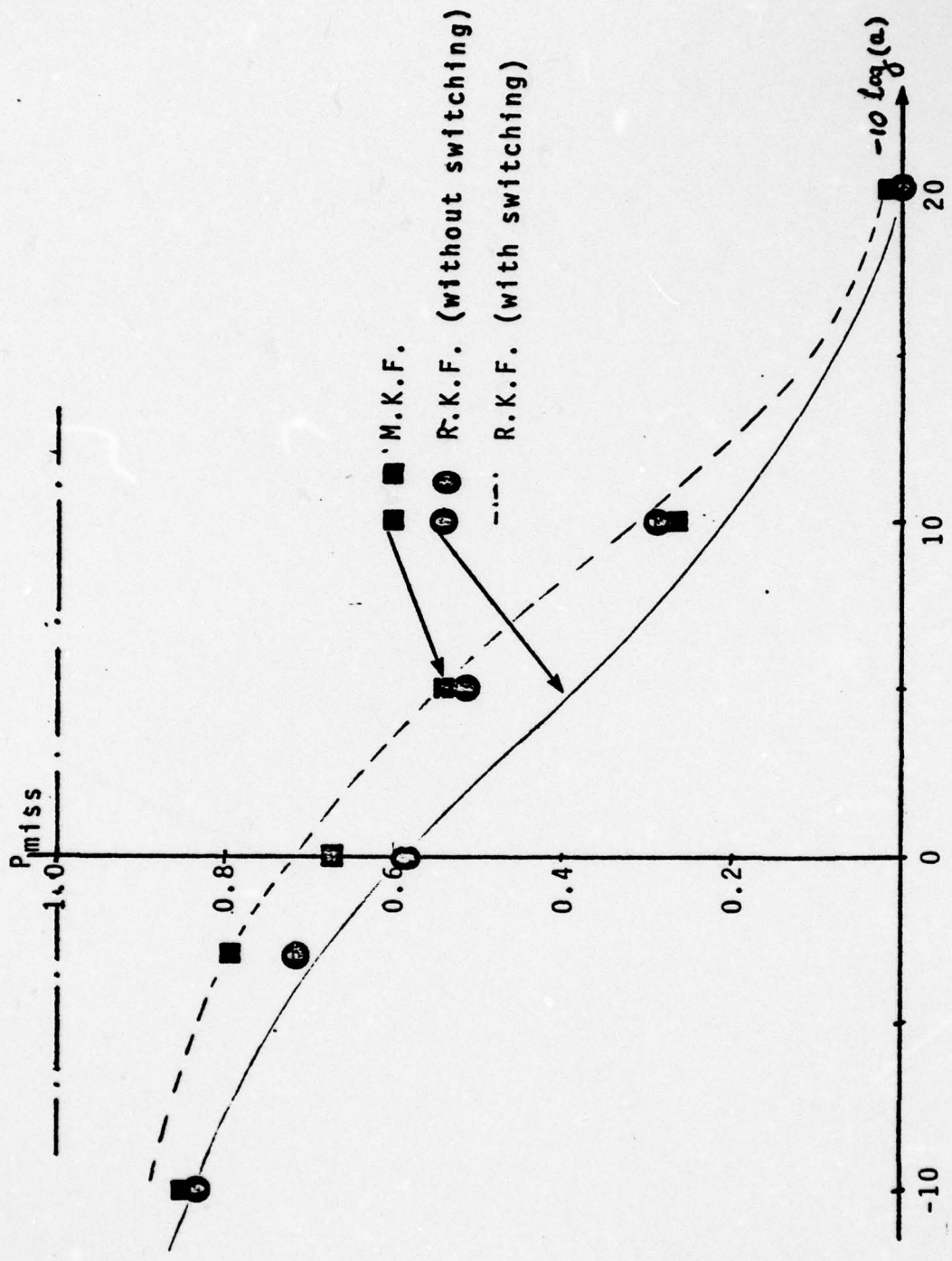

Figure 4.2-1. Probability of miss as a function of  $-10 \log(a)$ .

AD-A066 367

NAVAL POSTGRADUATE SCHOOL MONTEREY CALIF  
STOCHASTIC SEPARATION OF RADAR SIGNALS.(U)  
DEC 78 Z W SHLOMO

F/G 17/9

UNCLASSIFIED

NL

2 OF 3  
AD  
AD66367

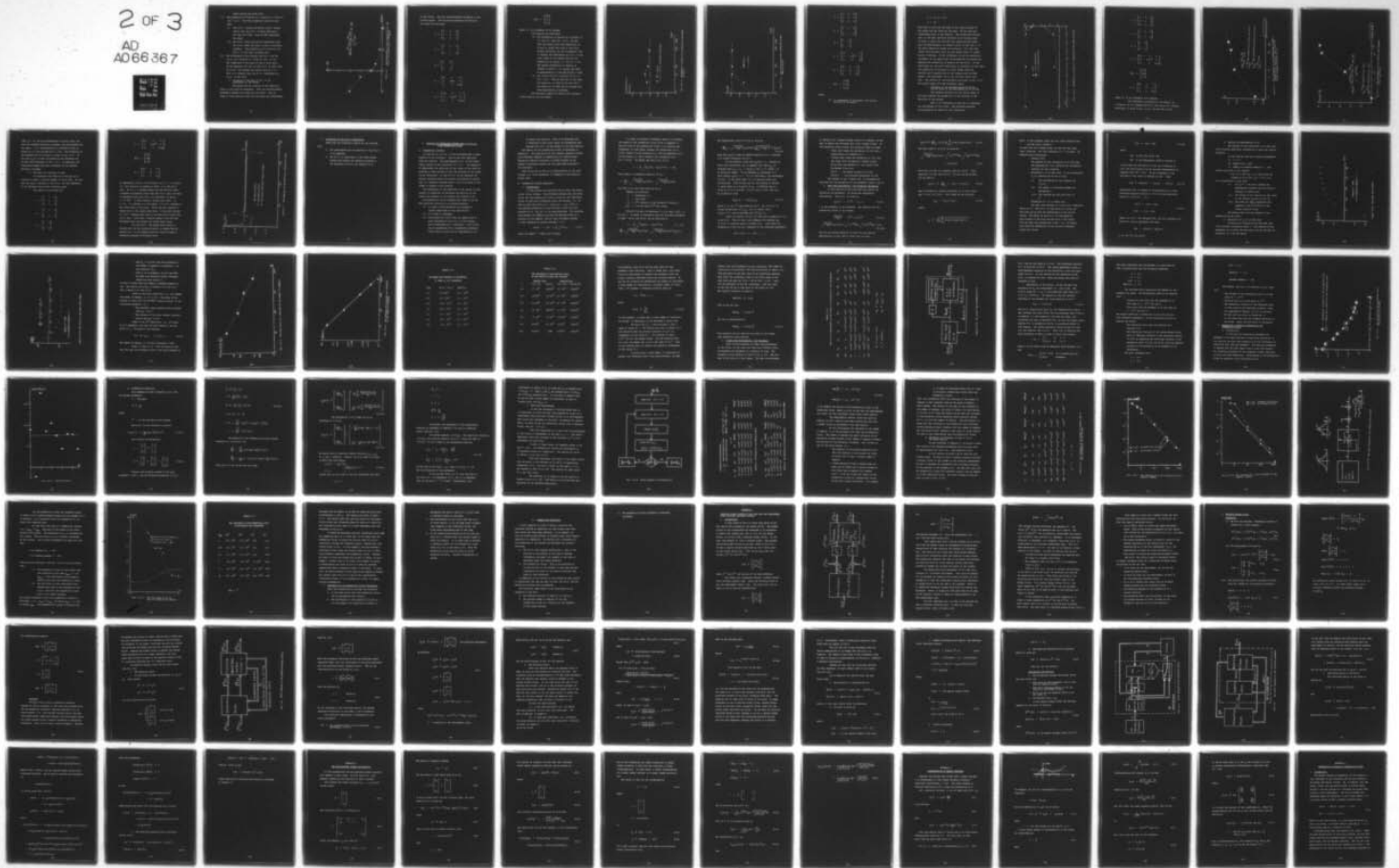

Three results are given here:

- (1). The probability of missing as a function of  $-10 \log(a)$  (Fig. 4.2-1). From the simulation results we see that:
  - (i) The R.K.F. (without switching) gives a better result than the M.K.F. (without switching), but they are close. Thus the MKF approaches the ideal.
  - (ii) The M.K.F. gives significant improvement over the R.K.F. where the input to both is switched randomly. (The probability of a miss for the R.K.F. in this case is almost one).
- (2). The difference in gain between the M.K.F. and the R.K.F. as a function of  $-10 \log(a)$  (Fig. 4.2-2). The comparison of the gains at TTG is given here. As was expected, the gain of the M.K.F. is lower than the R.K.F. and reaches the regular gain as  $a \rightarrow 0$ . This is an example where the M.K.F. approaches the R.K.F. in the limit.

b. Influence of the Mean of  $X(0)$  to the Performance of the Filter<sup>~</sup>

The height and the velocity of the chaff are taken in this case as parameters. Both are distinguishable parameters between the target and the chaff. Thus we study in this simulation how they influence the performances

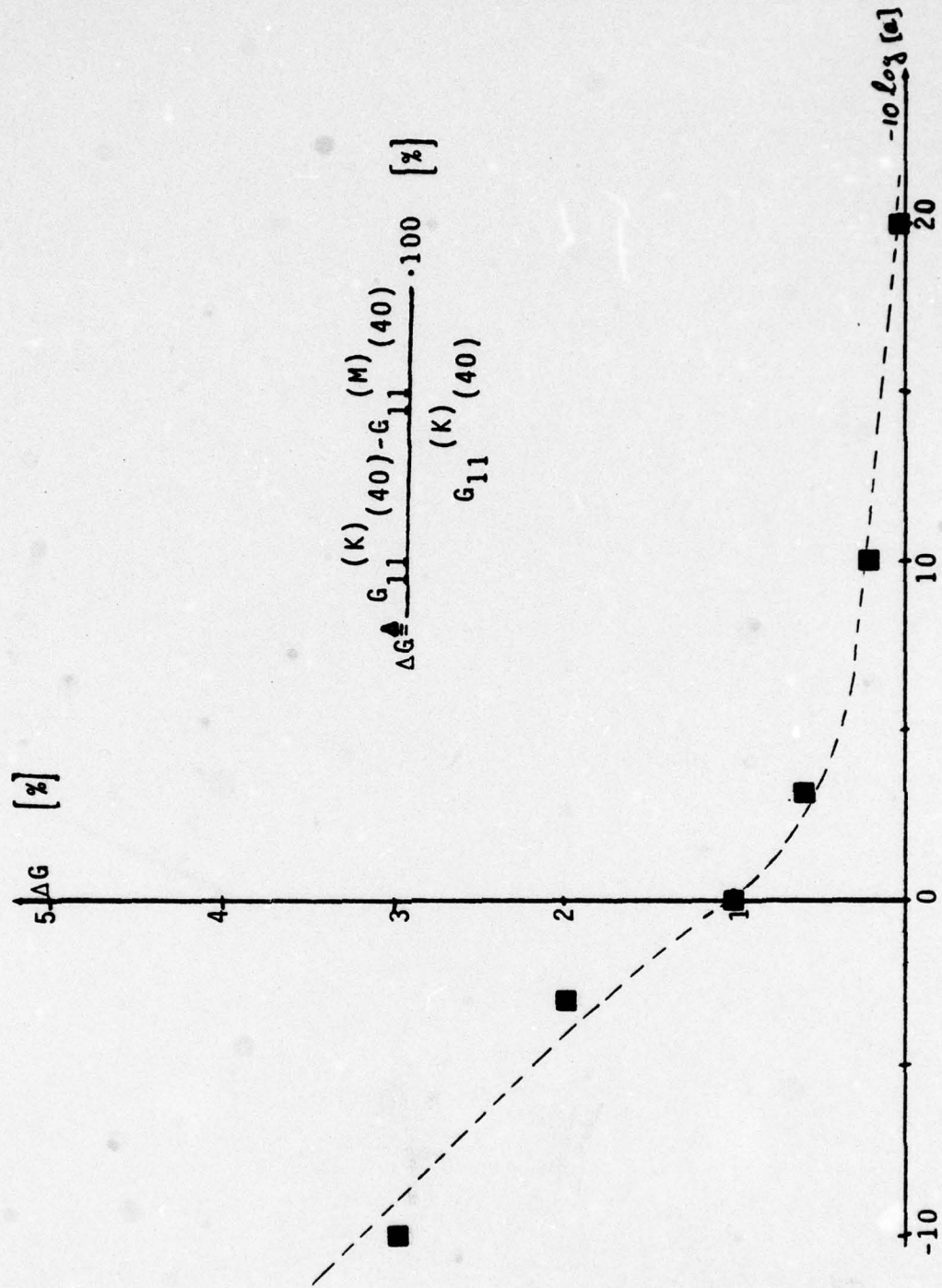

Fig. 4.2-2 The difference in gain between M.K.F. and R.K.F. as a function of  $-10 \log(a)$ .

of the filter. The most distinguishable parameter is the initial height. The following parameters and matrices are taken for this test:

$$\Phi = \begin{bmatrix} 1 & 0 & 0 \\ 0 & 1 & 1 \\ 0 & 0 & 1 \end{bmatrix}$$

$$C = \begin{bmatrix} 1 & 0 & 0 \\ 0 & 1 & 0 \end{bmatrix}$$

$$R = \begin{bmatrix} 1 & 0 \\ 0 & 1 \end{bmatrix}$$

$$M = \begin{bmatrix} 50 & 0 & 0 \\ 0 & 5000 & 0 \\ 0 & 0 & 0.5 \end{bmatrix}$$

$$Q = \begin{bmatrix} 1.0 & 0 & 0 \\ 0 & 9 \cdot 10^{-4} & 0 \\ 0 & 0 & 0.25 \end{bmatrix}$$

$$\bar{\mathbf{x}}(0) = \begin{bmatrix} 10 \\ a \\ -1 \end{bmatrix}$$

where "a" is a parameter to be changed.

Two results are given here:

- (1) The probability of missing as a function of "a" ( $\bar{x}_2(0)$ ) (see Fig. 4.2-3). We see from the results that the probability of a miss is larger than that of the R.K.F. without switching, as can be expected, and it reaches the performance of R.K.F. in the limit (when at the instant TTG the two heights are far apart,  $a > 100$  or  $a < 10$ ). The maximum probability of missing is reached at about  $a \approx 50$  (target and chaff as approximately at the same height at TTG).
- (2) The initial gain as a function of "a" in Fig. 4.2-4). Here we see that in the limit the gains are the same as for the R.K.F., and reduce to 0.5 when the two heights are indistinguishable as expected.

The following inputs for testing the influence of the velocity are now chosen:

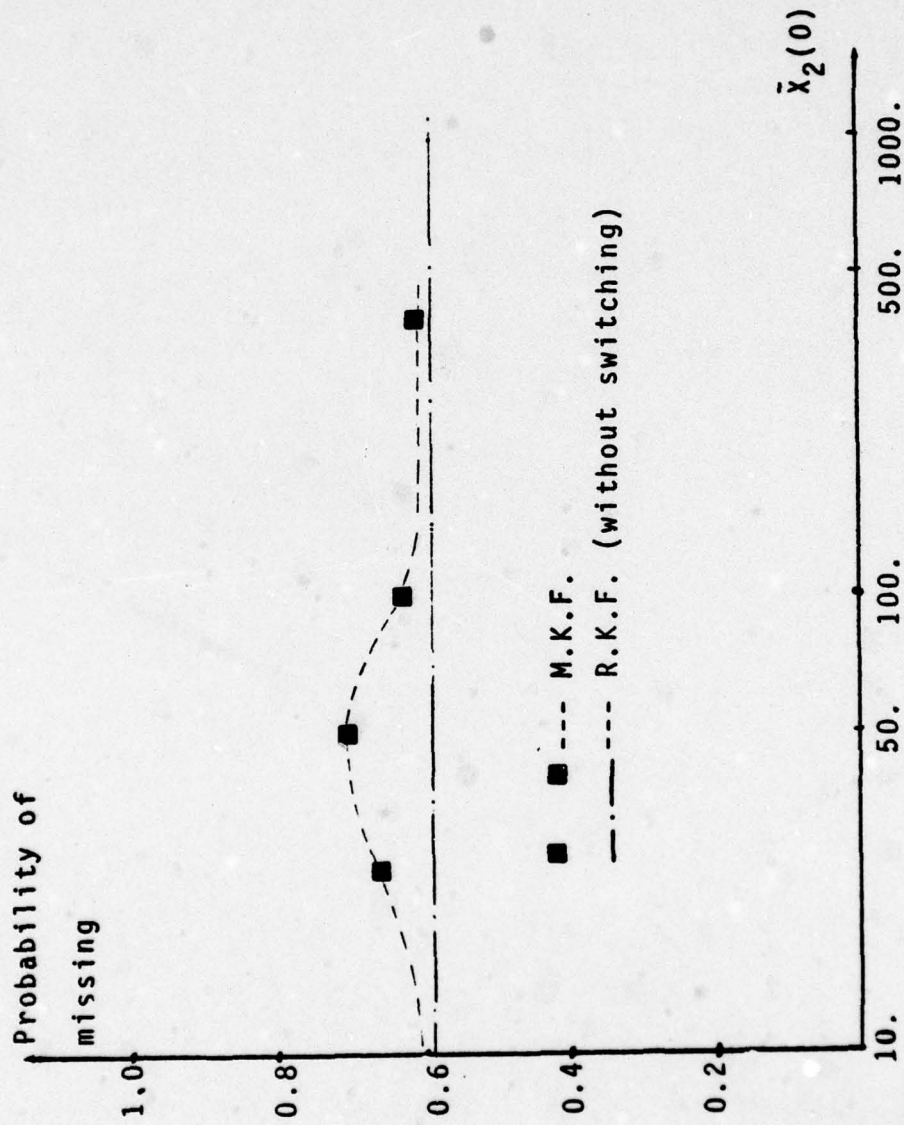

Fig. 4.2-3. Probability of miss as a function of the mean of  $X_2(0)$ .

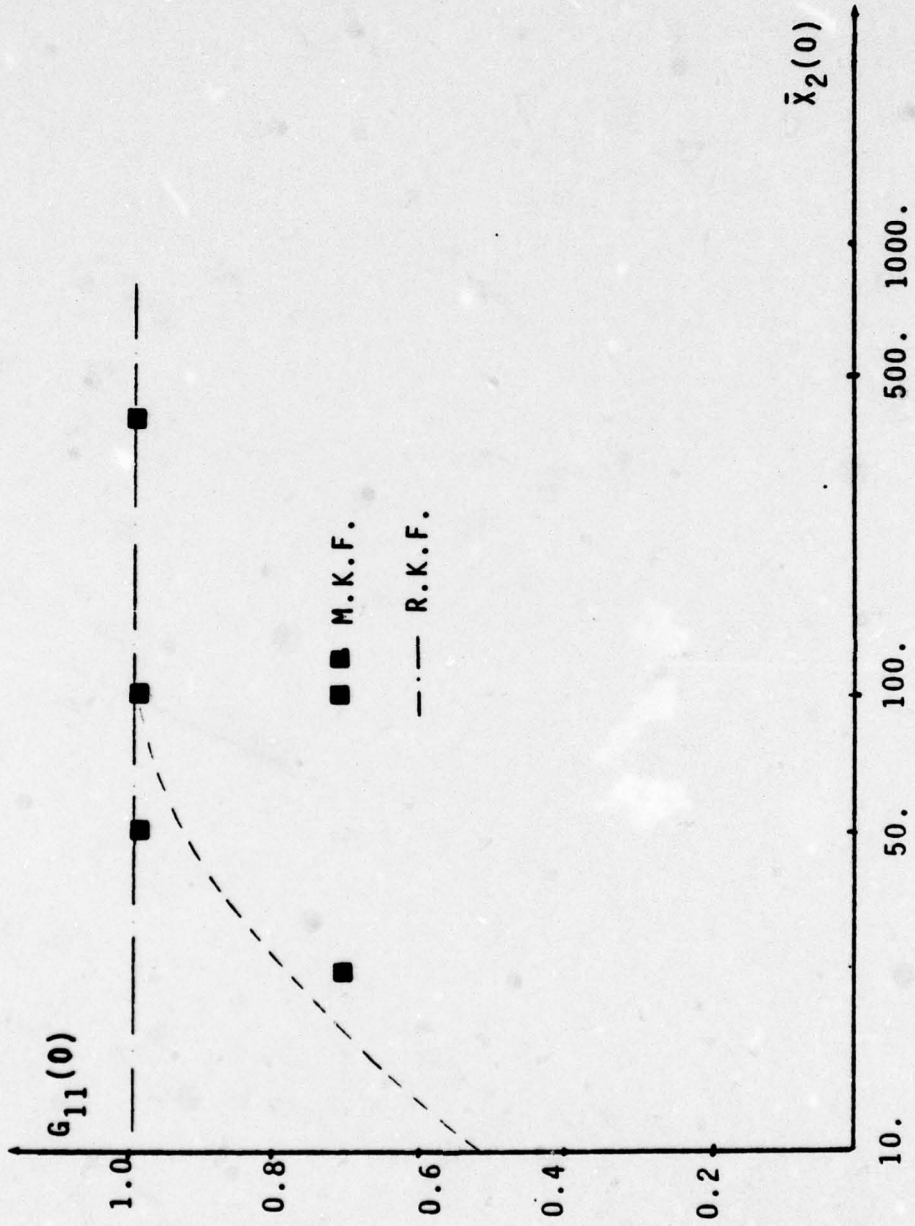

Fig. 4.2-4. The initial gain as a function of the mean of  $X_2(0)$ .

$$\Phi = \begin{bmatrix} 1 & 0 & 0 \\ 0 & 1 & 1 \\ 0 & 0 & 1 \end{bmatrix}$$

$$C = \begin{bmatrix} 1 & 0 & 0 \\ 0 & 1 & 0 \end{bmatrix}$$

$$R = \begin{bmatrix} 1 & 0 \\ 0 & 1 \end{bmatrix}$$

$$Q = \begin{bmatrix} 1.0 & 0 & 0 \\ 0 & 9 \cdot 10^{-4} & 0 \\ 0 & 0 & b^2 \end{bmatrix}$$

$$M = \begin{bmatrix} 25 & 0 & 0 \\ 0 & 25 & 0 \\ 0 & 0 & c^2 \end{bmatrix}$$

$$\bar{X}(0) = \begin{bmatrix} 10 \\ 10 \\ a \end{bmatrix}$$

where:

"a" is a parameter to be changed (the initial velocity of the chaff)

$$b = 0.1 a + 0.01$$

$$c = 2b$$

Note that in this test the mean of the initial height of the target and the chaff are the same. So the only distinguishable part is the velocity. The target has velocity zero, so the most difficult decision is at velocity zero. In order to check the case when the target and the chaff have the same dynamics, we choose  $b$  and  $c$  so that for  $a = 0$ , the chaff remains at almost zero velocity. For this case (chaff velocity about zero) we must expect about 0.5 probability of missing. As the difference in the two velocities increases, we can expect that the probability of missing will approach the probability of missing for the R.K.F. On the other hand, for the R.K.F. where there is switching in the input, the probability of missing is at the lowest value for velocity zero (because both of the targets have the same height), and approaches one as the velocity varies from zero. The results of the simulation are given in Fig. 4.2-5. The results agree with the discussion above.

c. Influence of the Standard Deviation of the Initial State to the Performance of the Filter

The standard deviation of the initial state of the chaff changes the probability of the decision at the beginning of the process.

Thus it is interesting to see how it influences the performance of the filter. The following matrices and parameters are taken for this simulation:

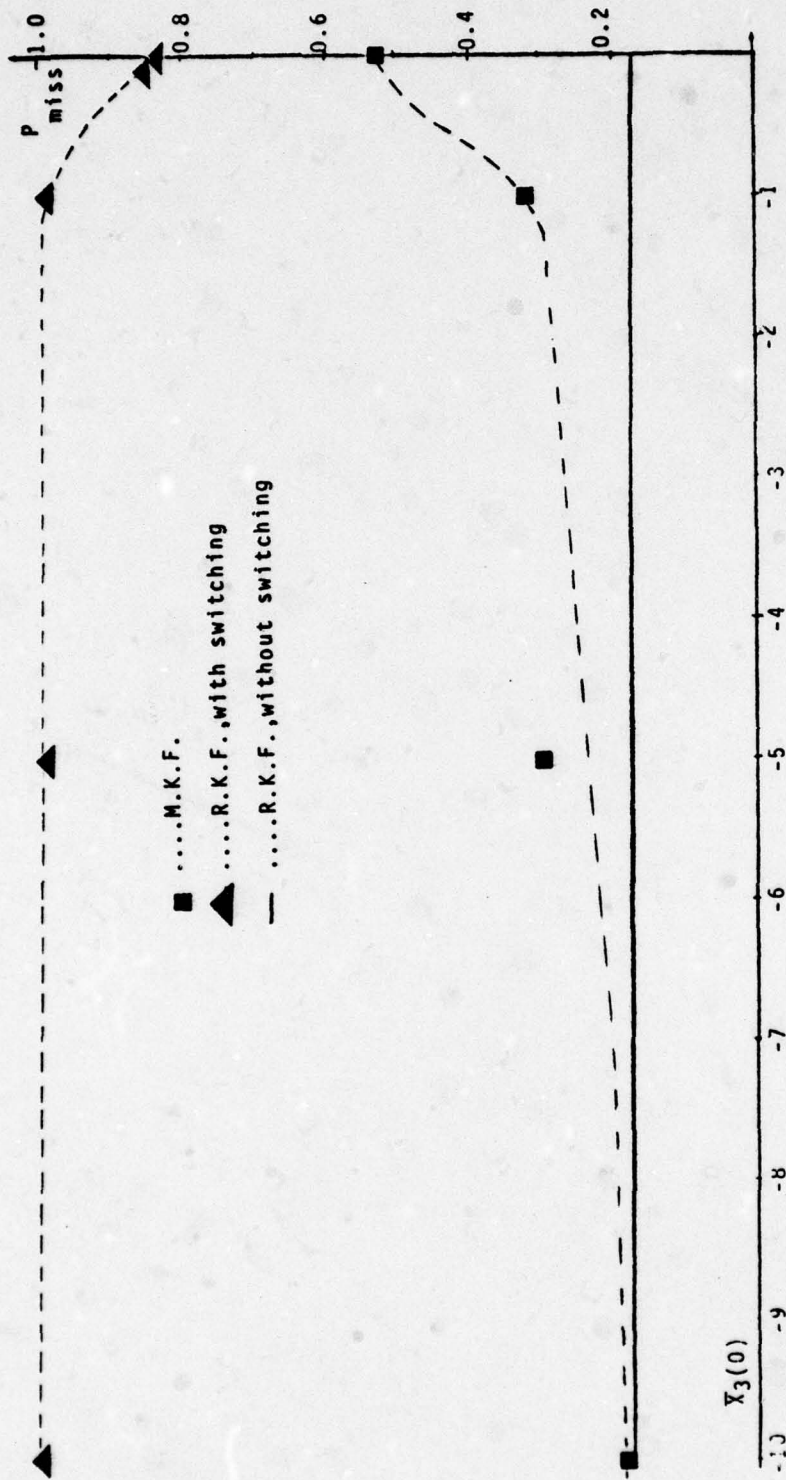

Fig. 4.2-5. Probability of miss as a function of the mean of  $X_3(0)$ .

$$\Phi = \begin{bmatrix} 1 & 0 & 0 \\ 0 & 1 & 1 \\ 0 & 0 & 1 \end{bmatrix}$$

$$C = \begin{bmatrix} 1 & 0 & 0 \\ 0 & 1 & 0 \end{bmatrix}$$

$$R = \begin{bmatrix} 1 & 0 \\ 0 & 1 \end{bmatrix}$$

$$Q = \begin{bmatrix} 1.0 & 0 & 0 \\ 0 & 9 \cdot 10^{-4} & 0 \\ 0 & 0 & 0.25 \end{bmatrix}$$

$$\bar{X}(0) = \begin{bmatrix} 10 \\ 100 \\ -1 \end{bmatrix}$$

$$M = \begin{bmatrix} 50 & 0 & 0 \\ 0 & a^2 & 0 \\ 0 & 0 & 0.5 \end{bmatrix}$$

where "a" is the parameter to be changed.

The difference in probability of missing, as a function of "a", between the M.K.F. and the R.K.F. (without switching) is given in Fig. 4.2-6. We see that in the

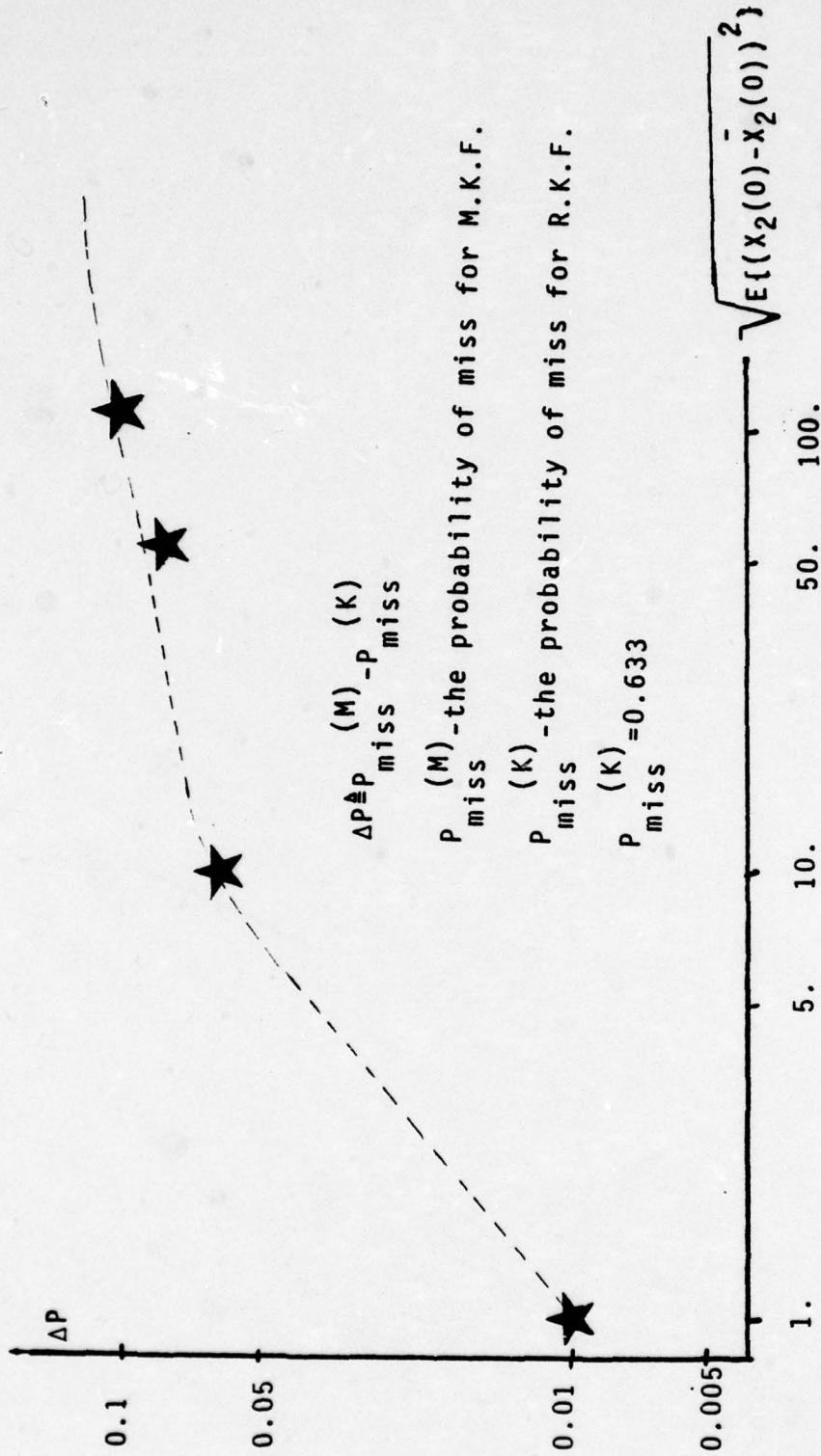

Fig. 4.2-6 . The difference in the probability of miss, between M.K.F. and R.K.F. as a function of the standard deviation of  $X_2$ .

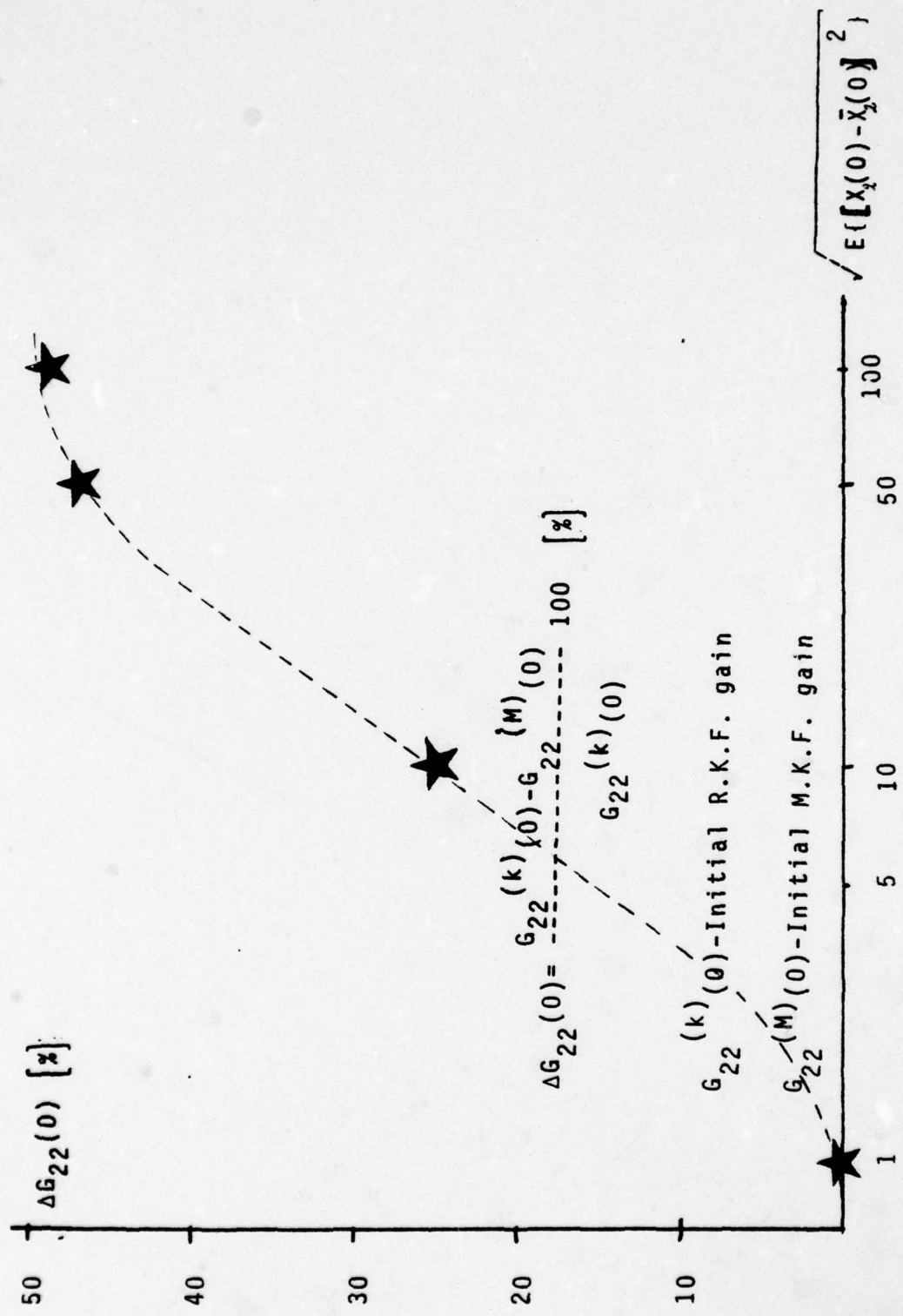

Fig. 4.2-7. The difference in the initial gain between M.K.F. and R.K.F.

limit ( $a \rightarrow 0$ ), the two performances are quite close, and when the standard deviation increases, the performances are far apart. I.e., the probability of missing for RKF is better by 0.1 over the MKF for a  $\approx 100$ ). The difference in gain between the two filters is given in Fig. 4.2-7. In the case  $G_{22}(0)$  is most influenced by the parameter and we show this difference in Fig. 4.2-7. As expected, the difference between the gains increases as the standard deviation increases.

d. The Gain as a Function of Time

To illustrate the behavior of the gain as a function of time, a typical example is given here. We know that the gains, contrary to the R.K.F. are data dependent; so for different data we get different gains.

The inputs to the system are:

$$\Phi = \begin{bmatrix} 1 & 0 & 0 \\ 0 & 1 & 1 \\ 0 & 0 & 1 \end{bmatrix}$$

$$C = \begin{bmatrix} 1 & 0 & 0 \\ 0 & 1 & 0 \end{bmatrix}$$

$$R = \begin{bmatrix} 1 & 0 \\ 0 & 1 \end{bmatrix}$$

$$Q = \begin{bmatrix} 1.0 & 0 & 0 \\ 0 & 9 \cdot 10^{-4} & 0 \\ 0 & 0 & 0.25 \end{bmatrix}$$

$$\tilde{X}(0) = \begin{bmatrix} 10 \\ 100 \\ -1 \end{bmatrix}$$

$$M = \begin{bmatrix} 50 & 0 & 0 \\ 0 & 10 & 0 \\ 0 & 0 & 0.5 \end{bmatrix}$$

An explanation of Fig. 4.2-8 follows. At  $K = 1$ ,  $\alpha$  is about 0.5, thus the gain is reduced to about .5 of the R.K.F. gain. At  $K = 4$ ,  $\alpha$  becomes almost one and the gain first increases and becomes larger than the R.K.F. gain, and then it decreases below the R.K.F. gain because  $\alpha$  is about 1 ( $\alpha \approx 0.998$ ). It then reaches a steady state gain. At  $K = 35$ ,  $\alpha$  is reduced to a low number ( $\alpha \approx 0.57$ ), because of the large noise in the input. Hence the gain reduces to almost half of the steady state gain. At the next instant ( $K = 36$ )  $\alpha$  becomes again about 1 and the gain is above the R.K.F. gain. After that  $\alpha$  remains almost 1 and the gain decreases again and reaches the steady state value.

For the M.K.F., the steady state value is reached only for the intervals where  $\alpha$  is almost one for several  $K$ 's. It can deviate from this value for short transients because of spurious noise.

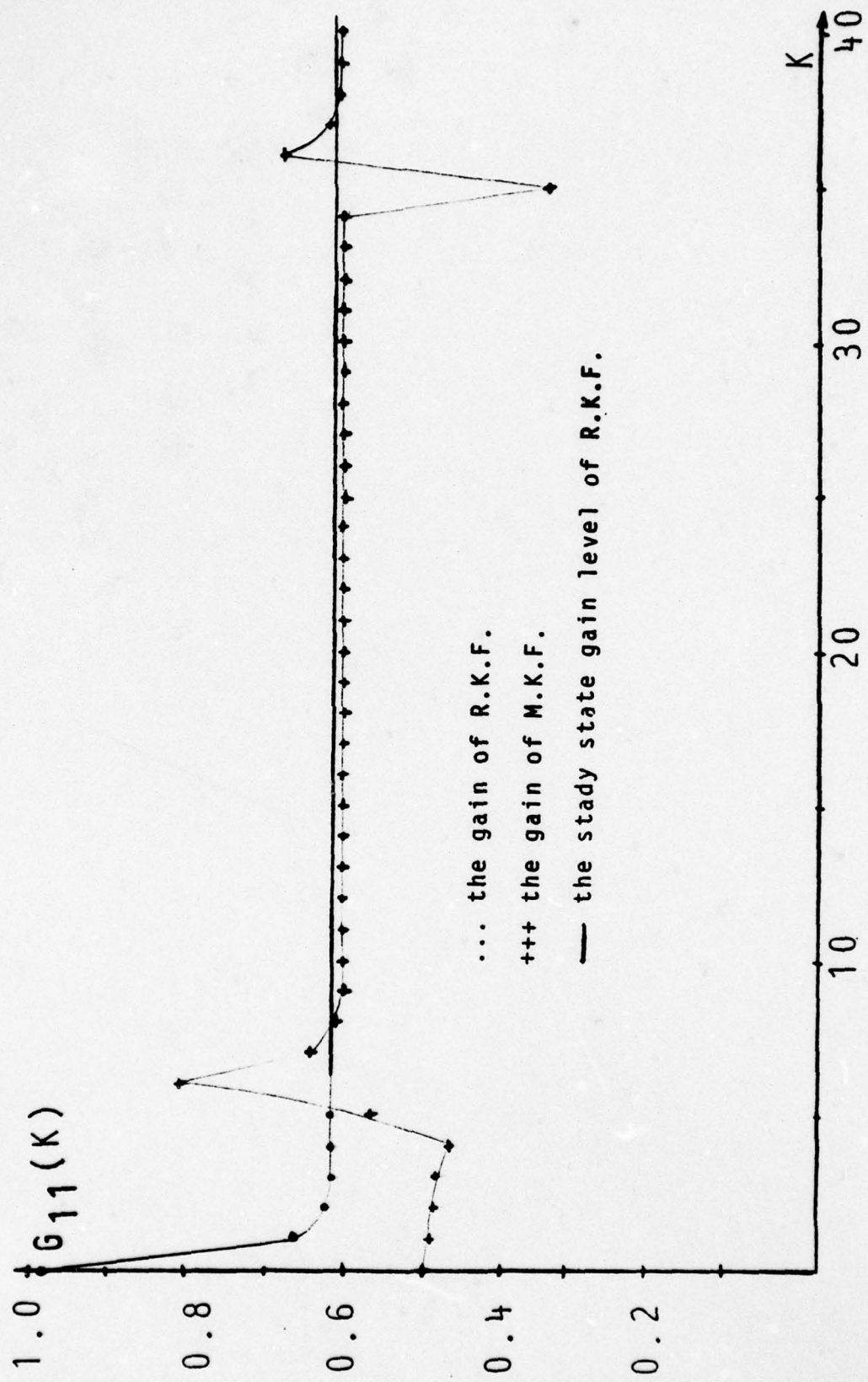

Fig.4.2-8 : The behavior of the Gain as a function of time.

### 3. Conclusion of the M.K.F. Simulations

Based upon the simulation results we can conclude that:

- a. The performances and the behavior of the M.K.F. is as expected.
- b. The M.K.F. is applicable to the chaff-target problem and handles the ambiguity problem in the monopulse solution (see Chapter IV.A).

V. SOLUTION FOR UNRESOLVED TARGETS FOR C.S. OR L.S.  
- THE PROBABILITY FILTER

A. THEORETICAL SOLUTION

In case of L.S. or C.S. it can be assumed that a phase detector is not available. Thus we get only amplitude from the receiver. The approximated p.d.f. of the return signal exists in the literature [8], [9]. Our purpose is to approximate the amplitude of the target or the chaff as received at each antenna so that the position of the target can be calculated. In case of C.S. we can separate the signals received during one conical scan period as equivalent to  $n$  separate antennas where  $n$  can be as large as the number of pulses in one rotation.

The information of the amplitude of the target at each antenna is sufficient to determine the position of the target with respect to the antenna (see Chapter II.B).

The probability filter proposed here seems to be the most practical solution to our problem because:

- (1) It gives a good estimation for parameters (signal amplitudes in this application).
- (2) It is easy to implement.
- (3) The probability filter does not depend upon an exact knowledge of the p.d.f. of the signals, and an approximation is sufficient. This filter can be implemented with a premeasured reference signal which is used with an approximate p.d.f.

to obtain the solution. This is an advantage over a likelihood filter which cannot be implemented here because the p.d.f. of the signals is not known exactly.

The theory for the probability filter is developed in Appendix D. The application of this general approach follows with simulated examples to demonstrate its effectiveness. Because we restrict ourselves to surface targets we can assume a stationary process for the amplitudes measured at the receivers.

Thus we can use (D-12b) as an approximation to the time average (i.e. with reasonable "T" compared to the missile's flight time).

## B. PROBABILITY FILTER SIMULATION

### 1. Introduction

In this section we give some results using the probability filter concept. The difference between the likelihood filter and the probability filter is that for the likelihood filter we need more information about the process, i.e., we need to know the joint p.d.f. ( $f_{\tilde{x}}(x_1, x_2, \dots, x_n)$ ), while in the proposed probability filter we have to know only the marginal p.d.f. ( $f_{x_i}(x)$ ) or its approximations. The relationship between the samples involved the expected value of a function of the samples, and for this the sample average is used (assuming an ergodic process), i.e.:

$$E\{f(Z)\} = \tilde{f}(Z) \cong \frac{1}{N} \sum_i f(Z(i)) \quad (5.2-1)$$

where the symbol "~" means time average.

In order to estimate a parameter vector  $\underline{\theta}$  we develop the theory of the probability filter given in Appendix D. The main idea of the probability filter is to minimize the difference, in some sense, between the conditional p.d.f.  $f[Z|\hat{\theta}]$  (where  $\hat{\theta}$  is the estimate of  $\underline{\theta}$ ), and the measured p.d.f. of the process,  $Z$ , which contains the information of  $\underline{\theta}$ ,  $\hat{f}(Z) = f(Z|\underline{\theta})$ . We choose the norm to be (D-11):

$$I = \frac{1}{2} \int_{-\infty}^{\infty} [f_Z(Z|\hat{\theta}) - \hat{f}_Z(Z)]^2 dz \rightarrow \min.$$

This leads to a necessary condition (D-12):

$$0 = \frac{\partial I}{\partial \hat{\theta}} = \int_{-\infty}^{\infty} \frac{\partial f_Z(Z|\hat{\theta})}{\partial \hat{\theta}} f_Z(Z|\hat{\theta}) dz - \int_{-\infty}^{\infty} \frac{\partial f_Z(Z|\hat{\theta})}{\partial \hat{\theta}} \hat{f}_Z(Z) dz$$

Our task is to solve this equation for  $\hat{\theta}$ .

Summary of notations:

- $\hat{\theta}$  = estimation of  $\underline{\theta}$
- $\underline{\theta}$  = true value
- $\hat{\theta}_j$  =  $j^{\text{th}}$  iteration in the process of finding  $\underline{\theta}$ .
- $\hat{\theta}(K)$  =  $\hat{\theta}$  at the end of  $N^{\text{th}}$  data block.

From D-12 we want to determine  $\hat{\theta} = \underline{\theta}$  so that  $\partial I / \partial \hat{\theta}_i = 0$  for all  $i$ . In order to accomplish this the following procedure is used: (D-11) and (D-12) can be rewritten as

$$I = \frac{1}{2} \int_{-\infty}^{\infty} [f_Z(Z|Y) - \hat{f}_Z(Z)]^2 dz \quad (5.2-1a)$$

$$\frac{\partial I}{\partial Y} = \int_{-\infty}^{\infty} \frac{\partial f_Z(Z|Y)}{\partial Y} f_Z(Z|Y) dz - \int_{-\infty}^{\infty} \frac{\partial f_Z(Z|Y)}{\partial Y} \hat{f}_Z(Z) dz \triangleq \underline{f}_T(Y, \underline{\theta})$$

The experimental value of  $\partial I / \partial \underline{Y}$  is given by

$$\left[ \frac{\partial I}{\partial \underline{Y}} \right]_E = \int_{-\infty}^{\infty} \frac{\partial f_Z(Z|\underline{Y})}{\partial \underline{Y}} f_Z(Z|\underline{Y}) dZ - \frac{1}{N} \sum_{i=1}^N \frac{\partial f_Z(Z(i)|\underline{Y})}{\partial \underline{Y}} \triangleq \underline{f}_E(\underline{Y}, \underline{\theta}). \quad (5.2-1b)$$

Note that  $\underline{f}_E(\underline{Y}, \underline{\theta})$  does not depend explicitly on  $\underline{\theta}$ , although  $\underline{\theta}$  of course influences the  $Z(i)$ .

We are seeking  $\underline{\theta}$  such that  $\underline{f}_E(\underline{\theta}, \underline{\theta}) = 0$ . Usually we solve this iteratively;  $\hat{\underline{\theta}}_0$  is guessed, and then  $\hat{\underline{\theta}}_{j+1}$  is obtained from  $\hat{\underline{\theta}}_{j+1} = \hat{\underline{\theta}}_j - \epsilon \cdot \underline{f}_E(\hat{\underline{\theta}}_j, \underline{\theta})$  for  $j \geq 0$ , where  $\epsilon$  is an arbitrary number. If the sequence  $\hat{\underline{\theta}}_j$  converges to  $\hat{\underline{\theta}}$ , then clearly  $\underline{f}_E(\hat{\underline{\theta}}, \underline{\theta}) = 0$ . If  $\epsilon$  is very small, the convergence is slow. On the other hand, if  $\epsilon$  is large we might get oscillations. Thus we must use for this method an optimal  $\epsilon$ , which might be a function of  $\underline{f}_E$ . A different way to solve for  $\hat{\underline{\theta}}$  is to use Eqs. (5.2-1a) and (5.2-1b) that can be iterated so that

$$\underline{f}_E(\hat{\underline{\theta}}_j, \underline{\theta}) = \underline{f}_T(\hat{\underline{\theta}}_j, \hat{\underline{\theta}}_{j+1}) \quad (5.2-1c)$$

where  $\hat{\underline{\theta}}_j$  is the  $j^{\text{th}}$  approximation for  $\hat{\underline{\theta}}$ . Eq. (5.2-1c) is solved successively for  $\hat{\underline{\theta}}_{j+1}$ , for  $n-1$  steps, until  $\underline{f}_E(\hat{\underline{\theta}}_n, \underline{\theta}) \cong 0$ , and we conclude that  $\hat{\underline{\theta}} \triangleq \hat{\underline{\theta}}_n \cong \underline{\theta}$ .

After we iterate (5.2-1c) for the first  $N$  samples of  $Z(i)$  we get  $\hat{\underline{\theta}}(1)$ . Then we take a new sequence of  $N$  samples and (5.2-1c) is iterated again to produce  $\hat{\underline{\theta}}(2)$ . Thus after the probability filter we get a sequence of the estimated parameters:

$$\{\hat{\underline{\theta}}(1), \hat{\underline{\theta}}(2), \dots, \hat{\underline{\theta}}(K), \dots\}.$$

If actually  $\theta(K)$  changes between blocks of N samples, we may want to smooth the estimates  $\hat{\theta}(K)$  with a Kalman filter. In the discussion which follows the following terms are used:

- "Open loop" means the estimation of  $\theta(K)$  with a single block of N samples  $Z(i)$ .
- "Closed loop" means the estimation of  $\theta(K)$  with the "open loop" followed by a Kalman filter.

As we know (see Appendix F), the outputs from the Kalman filter are

$\hat{\theta}(K|K)$  - the update estimation of  $\theta(K)$

$\hat{\theta}(K|K-1)$  - the predicted estimation of  $\theta(K)$

The concept of the "closed loop" is discussed and simulated for the estimation of one parameter (parts 2 and 3).

## 2. Open Loop Performance - One Parameter Estimation

In this section we give the open loop output for estimating one parameter. We choose the exponential distribution. The p.d.f. is given by:

$$f_Z(Z|\theta) = \theta e^{-\theta Z} \quad Z \geq 0 \quad (5.2-2)$$

$\theta$  is the parameter to be estimated. The equation for the probability filter is as follows:

$$\frac{\partial f_Z(Z|Y)}{\partial Y} = e^{-YZ} - YZ e^{-YZ} \quad (5.4-2a)$$

$$\int_0^{\infty} \frac{\partial f_Z(Z|Y)}{\partial Y} f_Z(Z|Y) dZ = \int_0^{\infty} Y e^{-2ZY} dZ - \int_0^{\infty} Y^2 Z e^{-2ZY} dZ = 0.25 \quad (5.2-2b)$$

Thus we can rewrite equation (5.2-1b) for our case by substituting (5.2-2a) and (5.2-2b) into (5.2-1b).

$$f_E(Y, \theta) \triangleq \left[ \frac{\partial I}{\partial Y} \right]_E = 0.25 - \frac{1}{N} \sum_{i=1}^N [1 - YZ(i)] \exp[-YZ(i)] \quad (5.2-3)$$

The first term in (5.2-1a) is given by:

$$\begin{aligned} \int_{-\infty}^{\infty} \frac{\partial f_Z(Z|Y)}{\partial Y} f_Z(Z|\theta) dZ &= \int_0^{\infty} \theta e^{-(\theta+Y)Z} dZ - \int_0^{\infty} \theta Y Z e^{-(\theta+Y)Z} dZ \\ &= [\theta/(\theta+Y)]^2 \end{aligned} \quad (5.2-4)$$

Note that (5.2-2b) is a special case of (5.2-4). From equations (5.2-2b) and (5.2-4), (5.2-1a) can be written for our case as

$$f_T(Y, \theta) \triangleq \left[ \frac{\partial I}{\partial Y} \right]_T = 0.25 - [\theta/(\theta+Y)]^2 \quad (5.2-5)$$

Now we iterate our solution according to (5.2-1c) using Eqs. (5.2-3) to (5.2-5). This leads to the solution:

$$\hat{\theta}_{j+1} = \hat{\theta}_j [\alpha_j / (1 - \alpha_j)] \quad (5.2-6)$$

where:

$$\alpha_j \triangleq \sqrt{\frac{1}{N} \sum_{i=1}^N [1 - \hat{\theta}_j Z(i)] \exp[-\hat{\theta}_j Z(i)]}$$

Note: If the argument under the root turns negative then one may take a larger N.

To show that this concept works, we now test the "open loop" criterion. For this simulation  $\theta = 1$  is taken. We perform three simulations:

- Testing  $\partial I / \partial Y$

The purpose of this simulation is to show that the experimental  $\partial I / \partial Y$  contains the information required for the iteration.

- Estimating  $\theta$  in an open loop. In this simulation  $\hat{\theta}_j$  is iterated and we try to find:

(i) The convergence of the iteration by (5.2-6).

(ii) The number of iterations needed for estimating  $\theta$ .

(iii) The variance and the bias error of  $\hat{\theta}$ .

- Estimating of  $\theta$  in a closed loop.

The open loop estimate of  $\theta$  acts like a measuring device for  $\theta$ . The R.K.F. is used here as a filter for this data and we test the performances of the overall system. The design of the R.K.F. is influenced by the variance of the error and the bias in the output from the open loop probability filter, i.e., we assume that after the probability filter we have a measured signal with noise.

$$\hat{\theta}(K) = \theta(K) + V(K) \quad (5.2-7a)$$

where

$\theta(K)$  is the true value, and

$V(K)$  is the measurement noise at instant  $K$ .

In this case the statistics of  $V(K)$  are a function of  $\theta(K)$ , and this function can be evaluated approximately by assuming that  $\hat{\theta}(K) = \theta(K)$ . We are interested in the variance of  $V(K)$  which is denoted by  $R(K)$ . Thus,

$$R(K) \triangleq \text{VAR}[V(K)] = R[\theta(K)] \approx R[\hat{\theta}(K)] \quad (5.2-7b)$$

The process  $\theta(K)$  is assumed to be described by a linear difference equation similar to (F-2) and the statistics similar to (F-3,4,5). I.e.,

$$\theta(K+1) = \phi\theta(K) + W(K) \quad (5.2-7c)$$

$$\hat{\theta}(K) = \theta(K) + V(K)$$

where, in (F-2),  $\theta(K)$  replaces  $X(K)$ , and  $\hat{\theta}(K)$  replaces  $Y(K)$ .

The R.K.F. can be implemented only when

$$R(K) = R[\theta(K)] \approx R[\hat{\theta}_n(K)] ,$$

$M$ ,  $Q$ , and  $\bar{\theta}(0)$  are given.

a. Testing the Experimental  $\partial I/\partial Y$

The purpose of this simulation is to show that  $\partial I/\partial Y$  contains sufficient information to close the loop by iteration.

In this case we take the following parameters:

- (1)  $\theta = 1.0$
- (2) Sample size - 1000
- (3) Number of ensemble members = 1. The

results are given in two figures:

- Fig. 5.2-1 and Fig. 5.2-2 which give the results of  $\partial I/\partial Y$  for  $\hat{\theta}_0/\theta = 0.5$  to 5.0.

It is significant to note that:

- (i) At  $\hat{\theta}_0/\theta = 1$  the error between the experimental gradient and the analytic gradient is almost zero.
- (ii) The values of the results are very close to the analytic values for all  $\hat{\theta}_0$ .
- (iii) The curve for  $[\frac{\partial I}{\partial \theta}]_E$  approaches the asymptotic line 0.25 which is the correct analytic value.

The results show that the concept of the probability filter works.

b. Estimation of  $\theta_0$  in an Open Loop

From the first simulation we have seen that  $\partial I/\partial Y$  contains information about  $\theta$ . The purpose of this experiment is to study the bias error and the variance of estimation of  $\theta$  for two cases:

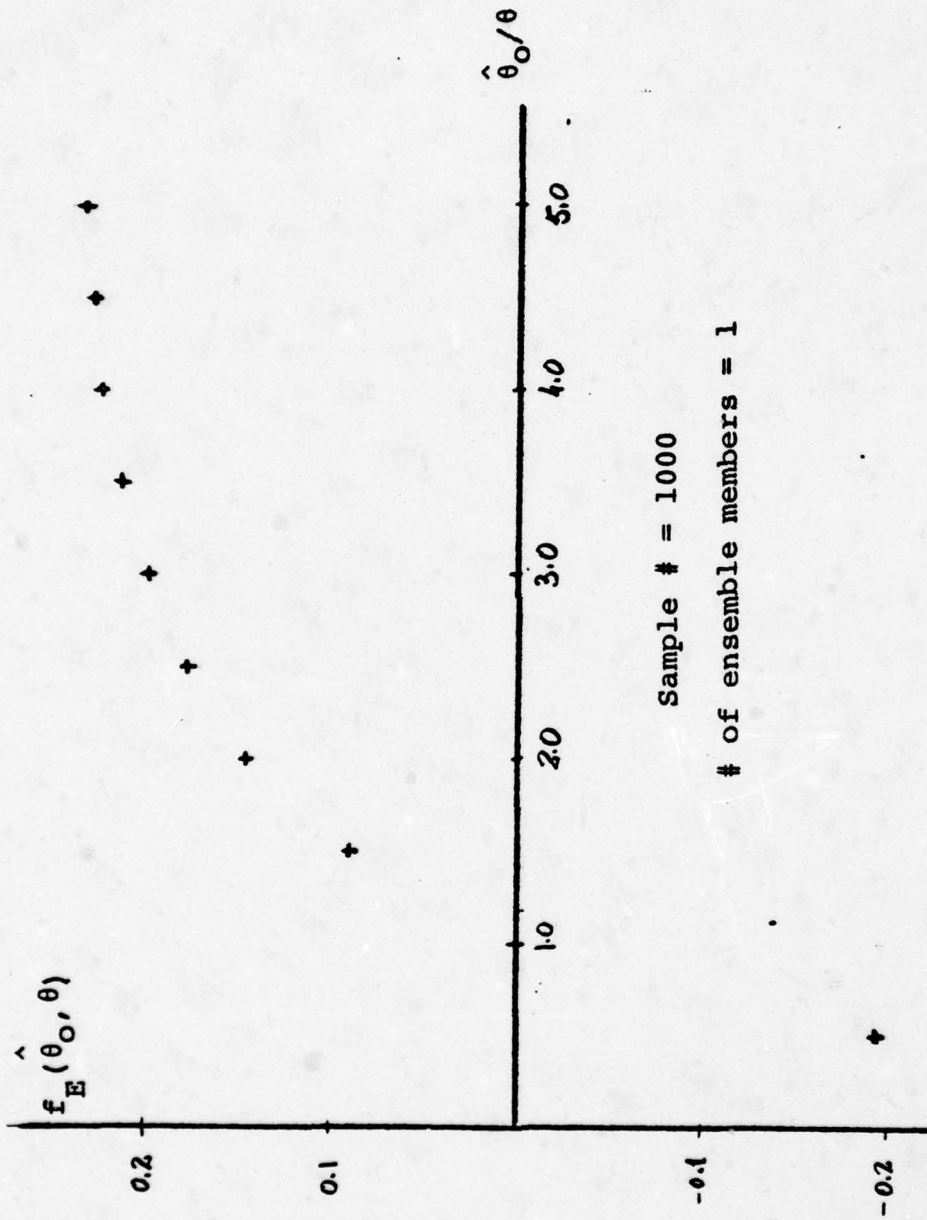

Figure 5.2-1. The open loop output.

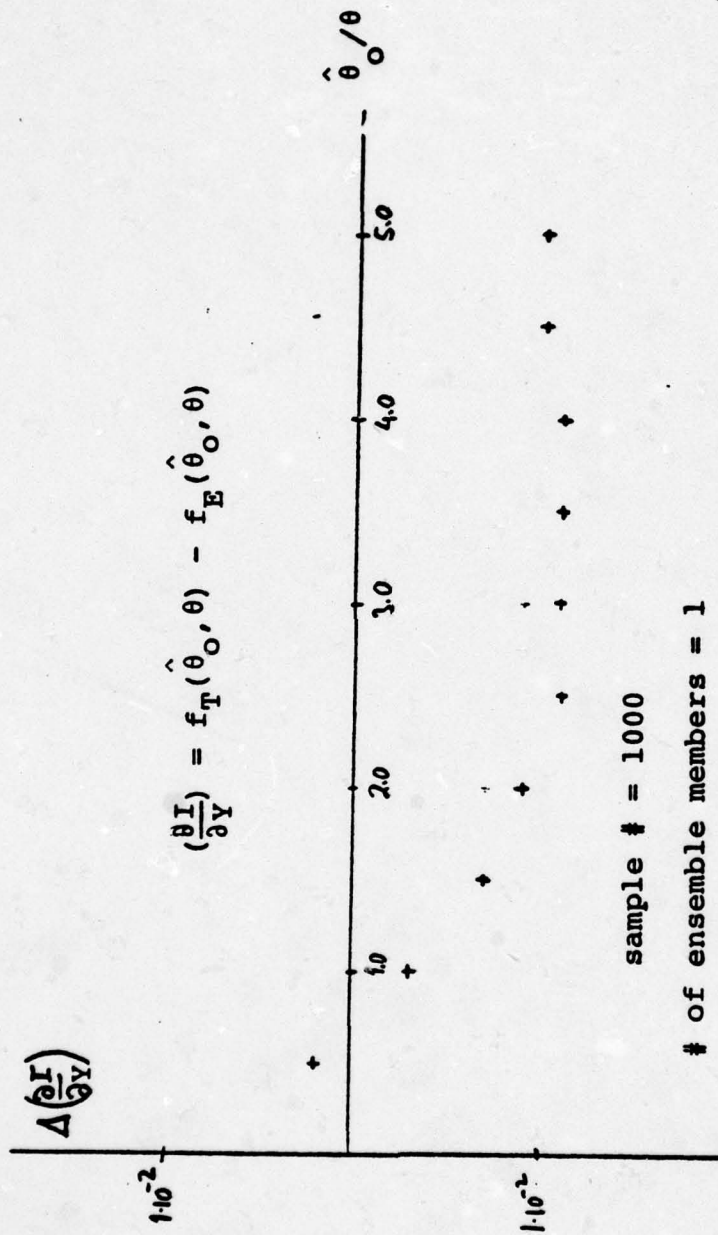

Figure 5.2-2. The error in the open loop output.

- when  $\hat{\theta}_0 = \theta$  we will see the influence of the number of samples on estimating  $\theta$ , by one iteration ( $\hat{\theta}_1$ ).
- when  $\hat{\theta}_0$  is a parameter, we will see that the open loop estimator always converges toward the true value of  $\theta$ .

In both of these cases the number of ensemble members is 500. The results are given in Figures 5.2-3 and 5.2-4 and in Tables 5.2-1 and 5.2-2.

Refer to the first simulation, i.e. one changes the number of samples,  $N$ , of (5.2-3). According to the figures it seems that the estimator behaves similar to the likelihood estimator, i.e.:

- The estimator seems asymptotically unbiased (see Fig. 5.2-3).
- The variance of the error reduces inversely with  $N$  (see Fig. 5.2-4).

Refer to the 2<sup>nd</sup> simulation, i.e., we change  $\hat{\theta}_0$  as a parameter, and look one step forward to see the error of  $\hat{\theta}_1$ . We define a new variable:

$$\hat{a}(j) \triangleq \hat{\theta}_j / \theta, \quad j = 0, 1, 2, \dots \quad (5.2-8)$$

The number of samples,  $N$ , for this simulation = 1000.

Refer to Table 5.2-1. From the table we see that the open loop estimator gives a very good estimate of

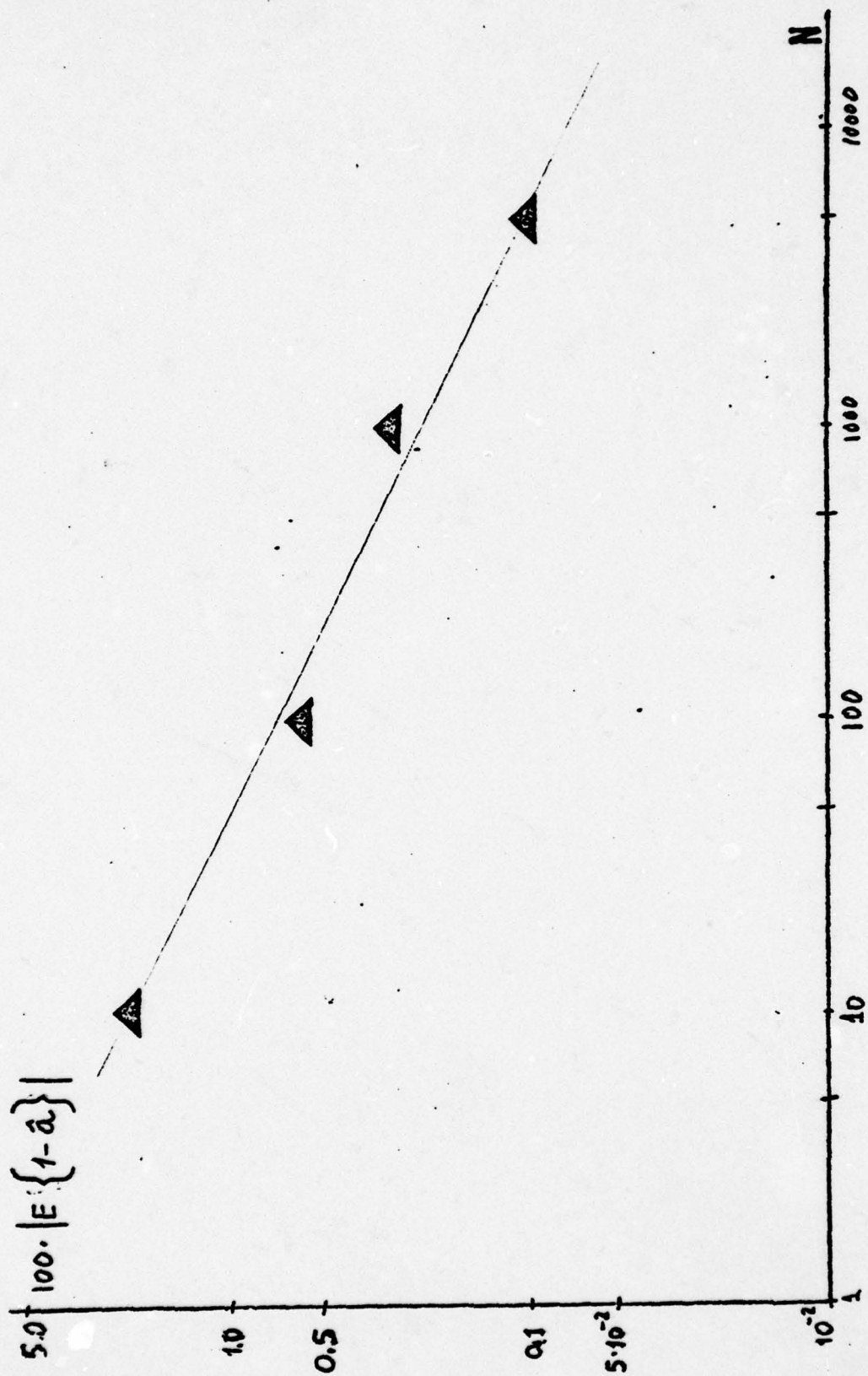

Fig. 5.2-3. The bias error as a function of the number of samples.

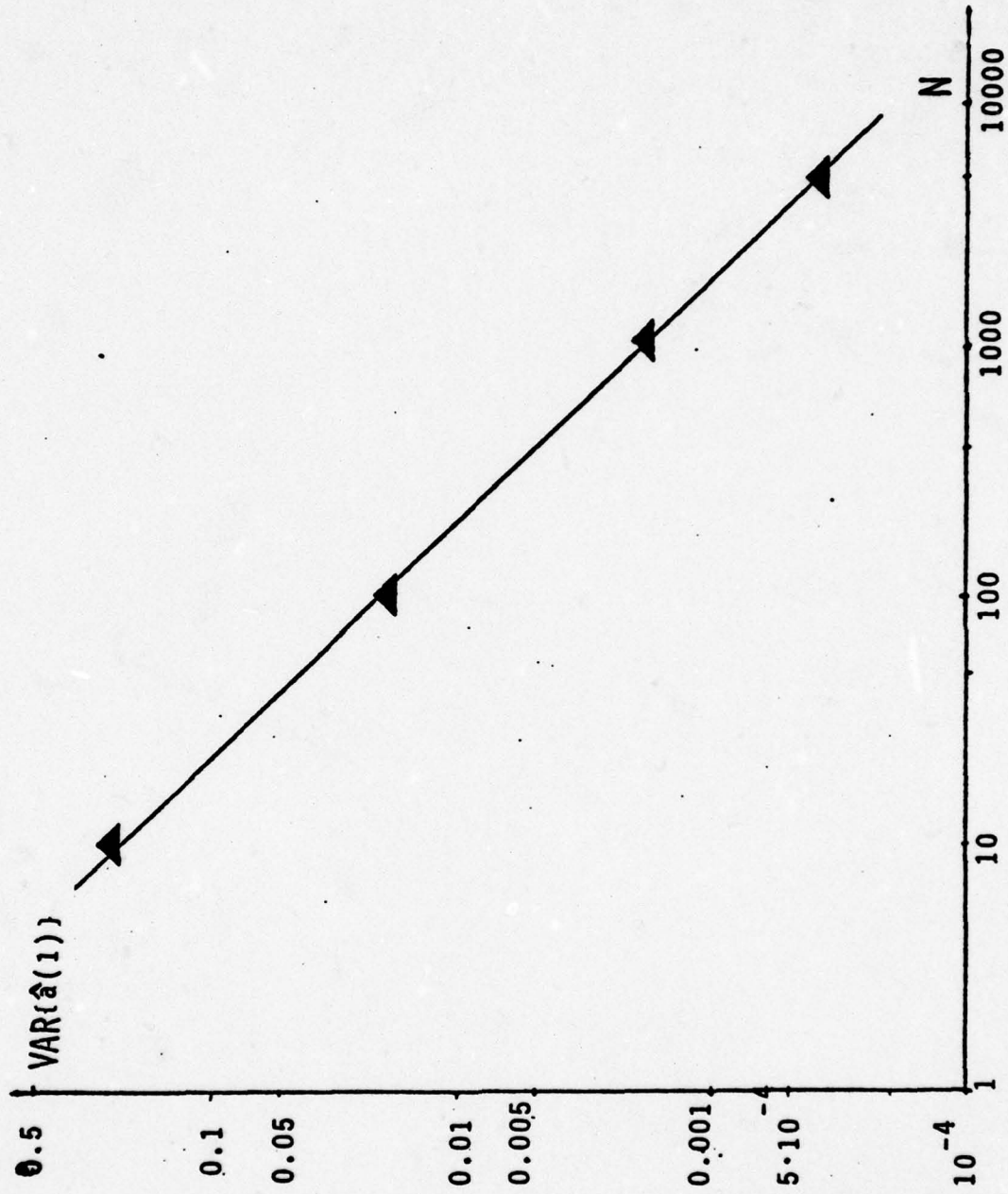

Fig. 5.2-4. The variance of the error as a function of the number of samples.

TABLE 5.2-1

THE ERROR AND VARIANCE OF ESTIMATING  
 $\hat{\theta}_1$  WHEN  $\hat{\theta}_0$  IS A PARAMETER

$\hat{a}(0)$	$E\{1.0 - \hat{a}(1)\}$	$\text{VAR}\{\hat{a}(1)\}$
0.1	$-1.2 \cdot 10^{-4}$	$9.4 \cdot 10^{-4}$
0.2	$-1.1 \cdot 10^{-3}$	$1.1 \cdot 10^{-3}$
0.5	$-1.9 \cdot 10^{-4}$	$1.4 \cdot 10^{-3}$
1.0	$-2.0 \cdot 10^{-3}$	$2.1 \cdot 10^{-3}$
1.5	$1.7 \cdot 10^{-3}$	$3.1 \cdot 10^{-3}$
2.0	$8.7 \cdot 10^{-4}$	$4.2 \cdot 10^{-3}$
5.0	$1.8 \cdot 10^{-2}$	$2.2 \cdot 10^{-2}$

TABLE 5.2-2

THE INFLUENCE OF THE ABSOLUTE VALUE  
TO THE RELATIVE ERROR AND VARIANCE

$\theta$	Absolute Value		Relative Value	
	$E\{\theta - \hat{\theta}_1\}$	$\text{Var}\{\hat{\theta}_1\}$	$E\{1 - \hat{a}(1)\}$	$\text{Var}(\hat{\theta}_1/\theta^2)$
0.1	$-2 \cdot 10^{-4}$	$2.06 \cdot 10^{-5}$	$-2 \cdot 10^{-3}$	$2.06 \cdot 10^{-3}$
0.2	$-4.5 \cdot 10^{-4}$	$7.5 \cdot 10^{-5}$	$2.3 \cdot 10^{-3}$	$1.88 \cdot 10^{-3}$
0.5	$2.9 \cdot 10^{-4}$	$5.2 \cdot 10^{-4}$	$5.8 \cdot 10^{-4}$	$2.06 \cdot 10^{-3}$
1.0	$-2 \cdot 10^{-3}$	$2.06 \cdot 10^{-3}$	$-2 \cdot 10^{-3}$	$2.06 \cdot 10^{-3}$
2.0	$9 \cdot 10^{-4}$	$7.9 \cdot 10^{-4}$	$4.5 \cdot 10^{-3}$	$1.96 \cdot 10^{-3}$
5.0	$5.6 \cdot 10^{-3}$	$5.1 \cdot 10^{-2}$	$1.1 \cdot 10^{-3}$	$2.05 \cdot 10^{-3}$
10.0	$5.9 \cdot 10^{-3}$	0.206	$5.9 \cdot 10^{-4}$	$2.06 \cdot 10^{-3}$

the parameter, even if we are far away from the true parameter value initially. Thus it seems that a few iterations are good enough to estimate the parameter since the single iteration used here gives such accurate results. We can use two criteria for determining the number of iterations: a fixed number of iterations or a flexible number of iterations. For example, a stopping criterion might be

$$|1.0 - \hat{a}^*(K)| \leq \epsilon \quad (5.2-9)$$

where

$$\hat{a}^*(K) \triangleq \frac{\hat{\theta}_K}{\hat{\theta}_{K-1}} \quad (5.2-10)$$

In this example, it seems that a fixed number of iterations are enough. A simulation is now performed to prove this.

We start with  $\hat{\theta}_0 = \theta$  and calculate  $\hat{\theta}_1$  for a range of values of  $\theta$ . The results are given in Table 5.2-2 and indicated that the relative variance of  $\theta_1/\theta^2$  is independent of the value of  $\theta$ . The variance is about  $2 \cdot 10^{-3}$  for all the tested values. And the relative error is a very low number and it is of the order of  $10^{-3}$ . Thus we can conclude that our results are generally independent of the values of  $\theta$ .

To prove that a fixed number of iterations are enough (two iterations give a very good estimate), we make

several runs with different initial conditions. The number of iterations is 10 and  $N=1000$ . The results are given in Table 5.2-3. From the table we see that there is no significant improvement after two iterations, even if our first value is far away from the real one ( $\hat{a}(0) = 100$  or  $\hat{a}(0) = 0.01$ ). Thus for the estimator we use two iterations. From the table we see that we get a bias error on the order of 0.2%. The relative variance is given by:

$$\text{VAR}[\hat{a}(2)] \triangleq 0.002$$

Thus we can say that

$$\text{VAR}[\hat{\theta}_2] = 0.002 \theta^2$$

and can be approximated by:

$$\text{VAR}[\hat{\theta}_2] \approx 0.002 \hat{\theta}_2^2 \quad (5.2-11)$$

This equation will be used for the noise in the closed loop simulation which follows.

### 3. Closed Loop Performances - One Parameter

After we have examined the open loop performance of the filter, we can close the loop with a Kalman filter and estimate the parameter as a function of time. The conceptual block diagram is given in Fig. 5.2-5. The concept of the filter is very simple. The open loop estimate

TABLE 5.2-3

Test of the Improvement by the number of iterations to the estimation

$\hat{a}(0)$	$E_1$	$V_1$	$E_2$	$V_2$	$\Delta E_2$	$\Delta V_2$	$\Delta E_3$	$\Delta V_3$	$\Delta E_\infty$	$\Delta V_\infty$
100	-1.3	3.1	-3.1·10 <sup>-3</sup>	9.1·10 <sup>-3</sup>	2·10 <sup>-3</sup>	5·10 <sup>-3</sup>	10 <sup>-3</sup>	10 <sup>-4</sup>	10 <sup>-8</sup>	10 <sup>-9</sup>
10	8.1·10 <sup>-3</sup>	8.1·10 <sup>-2</sup>	-2.6·10 <sup>-2</sup>	2.2·10 <sup>-3</sup>	5·10 <sup>-4</sup>	10 <sup>-4</sup>	10 <sup>-5</sup>	10 <sup>-5</sup>	10 <sup>-8</sup>	10 <sup>-9</sup>
2	-2.6·10 <sup>-3</sup>	3.9·10 <sup>-3</sup>	-3.8·10 <sup>-3</sup>	1.0·10 <sup>-3</sup>	5·10 <sup>-4</sup>	10 <sup>-7</sup>	3·10 <sup>-7</sup>	10 <sup>-6</sup>	5·10 <sup>-8</sup>	10 <sup>-9</sup>
1	2·10 <sup>-3</sup>	2.2·10 <sup>-3</sup>								
0.1	-9.4·10 <sup>-4</sup>	1.1·10 <sup>-3</sup>	-2.3·10 <sup>-3</sup>	1.9·10 <sup>-3</sup>	5·10 <sup>-4</sup>	10 <sup>-5</sup>	2·10 <sup>-6</sup>	5·10 <sup>-8</sup>	10 <sup>-8</sup>	10 <sup>-9</sup>
0.01	-2·10 <sup>-4</sup>	10 <sup>-3</sup>	-2·10 <sup>-3</sup>	2.1·10 <sup>-3</sup>	10 <sup>-3</sup>	10 <sup>-5</sup>	5·10 <sup>-6</sup>	10 <sup>-6</sup>	2·10 <sup>-8</sup>	10 <sup>-9</sup>

$$E_i \triangleq E\{1.0 - \hat{a}(i)\} \quad \Delta E_i \triangleq |E_{i+1} - E_i|$$

$$V_i \triangleq \text{VAR}\{\hat{a}(i)\} \quad \Delta V_i \triangleq |V_{i+1} - V_i|$$

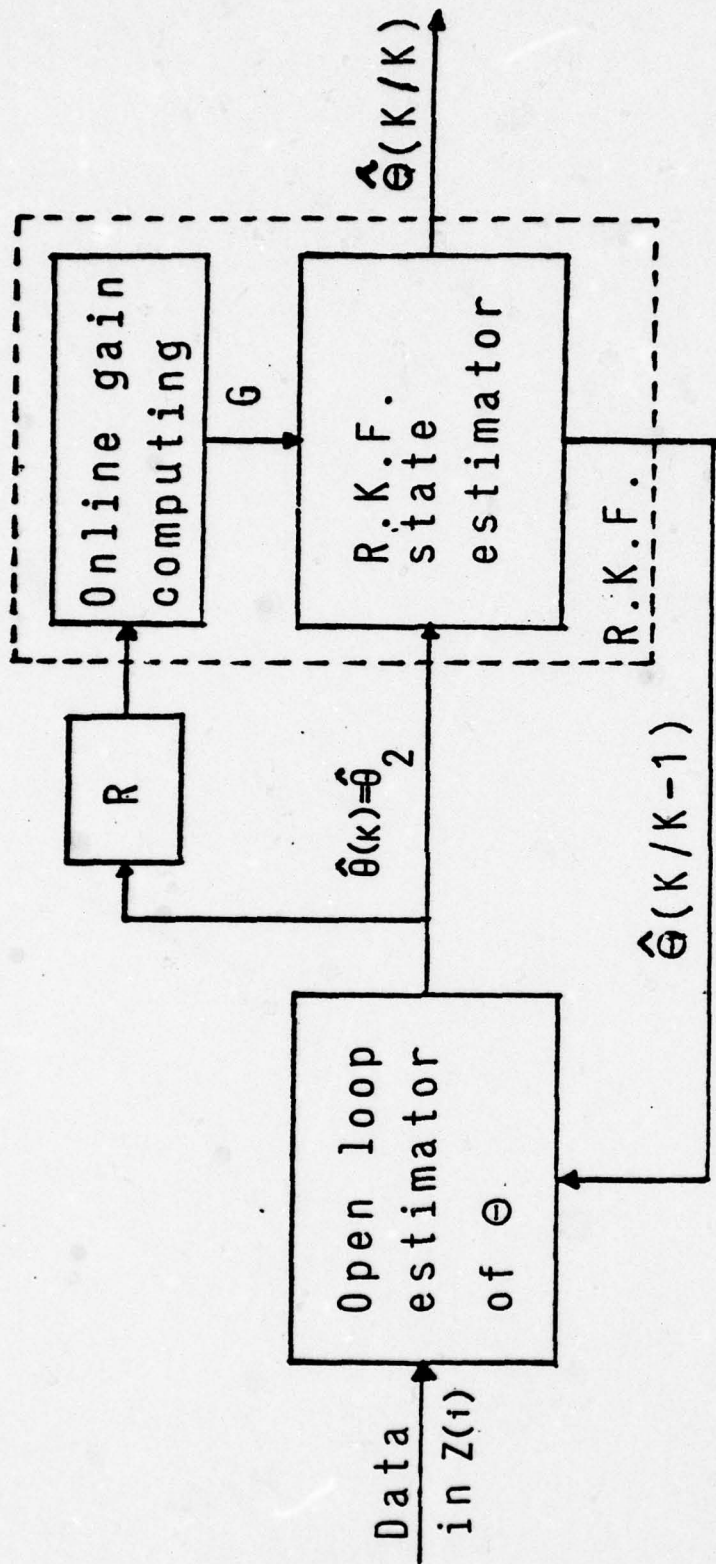

Figure 5.2-5. The close loop estimation of  $\theta$

of  $\theta$ , acts as the input to a R.K.F. The difference equation of  $\theta$  is given by (5.2-7c). The random measurement noise is data dependent according to the simulation in the last paragraph (5.2-11). So the variance of the estimation noise,  $R(K)$ , is computed on line. Hence the Kalman gain must be computed on line.

Explanation to the figure: We use the open loop estimator for  $\hat{\theta}_2$  as a measurement of  $\theta$  plus noise. The initial guess for  $\theta$ ,  $\hat{\theta}_2$ , is the predicted state from R.K.F. (i.e.  $\hat{\theta}_0 = \hat{\theta}(K|K-1)$ ). We compute on line the variance according to the assumed  $R(K)$  using equation (5.2-11):

$$R(K) \cong 0.002 \hat{\theta}_2^2 \quad (5.2-12)$$

The R.K.F. receives the input  $\hat{\theta}_2$ , the computed  $R(K)$ , and we then estimate the state  $\hat{\theta}(K|K)$  and the predicted state  $\hat{\theta}(K|K-1)$ . In summary;  $N = 1000$  samples of the data are taken, two iterations are used to estimate  $\hat{\theta}(K)$ , so that the Kalman filter updates  $\hat{\theta}(K)$  in probability filter in successive blocks of 1000 samples. The random generators which provide  $W(K)$  and  $\theta(0)$  are Gaussian (see 5.2-7c). Since  $\theta(K)$  is positive the above procedure is made in order to avoid this problem:

$$\theta(0) = \begin{cases} b & \text{if } b > 0 \\ \bar{\theta}(0)/5 & \text{if } b \leq 0 \end{cases}$$

where  $b$  is the output from the generator which produces  $\theta(0)$ .

And:

$$\theta(K+1) = \begin{cases} \phi\theta(K) + W(K) & \text{if it became positive} \\ \theta(K)/5 & \text{elsewhere.} \end{cases}$$

The first simulation that we perform is a case where we have a process which has the following parameters:

$$\begin{aligned}\phi &= 1.0 \\ Q &= 0.1 \\ \bar{\theta}(0) &= 1.0 \\ \text{VAR}\{\theta(0)\} &= 1.0\end{aligned}$$

For the Monte Carlo simulation 250 members of the ensemble are taken. The performances come out as expected with:

- Variance of the error over the ensemble is of the order of  $4 \cdot 10^{-3}$ , for all K.
- Bias error over the ensemble is of the order of  $2 \cdot 10^{-3}$ , for all K.

The second simulation is identical to the first one but with different parameters. In this simulation we want to examine two things:

- The estimation error bias and variance as a function of K.
- The theoretical variance of the random measure noise which is computed according to the experiment formula (5.2-12) by comparing the calculated variance in the estimation using (5.2-12) and (F-10) with the measured variance of the estimation of an ensemble of 250 experiments.

The input parameters are:

$$\begin{aligned}\phi &= 0.9 \\ Q &= 0.5\end{aligned}$$

$$\bar{\theta}(0) = 5.0$$

$$\text{VAR}\{\theta(0)\} = 2.0$$

$$\text{Ensemble members} = 250$$

The results (see Fig. 5.2-6 and Fig. 5.2-7), show that:

- The variance of the estimation error is on the order of  $2 \cdot 10^{-2}$ .
- The bias error is on the order of  $10^{-2}$ .
- The theoretical variance of the estimated error is very close to the simulated variance. Thus our experimental formula (5.2-12) is accurate.
- We know that our error is biased but it is one order less than the standard deviation of the error. Hence the bias error is negligible.

#### 4. Estimation of Several Parameters by the Probability Filter

##### a. Introduction

In the last two sections we estimated one parameter in an open loop and a closed loop simulation. In this section the open loop probability filter performance is tested for more than one parameter. For multiple parameters it appears that we often cannot find a close form formula for iteration procedure for the parameter values, some have to solve for them numerically. Performances of the probability filter is compared to the likelihood filter.

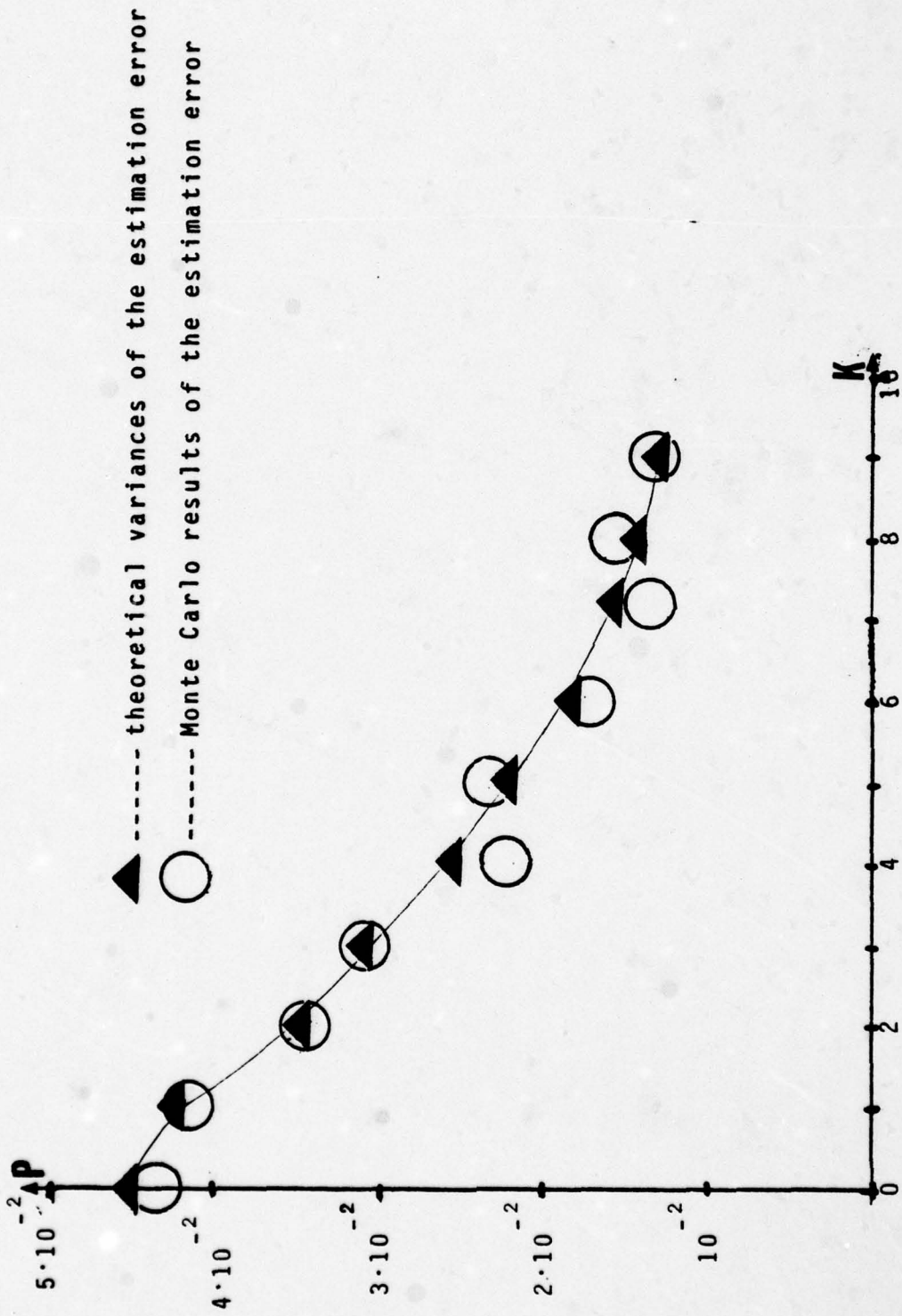

Fig. 5.2-6. The variance of the estimation error theoretical and results.

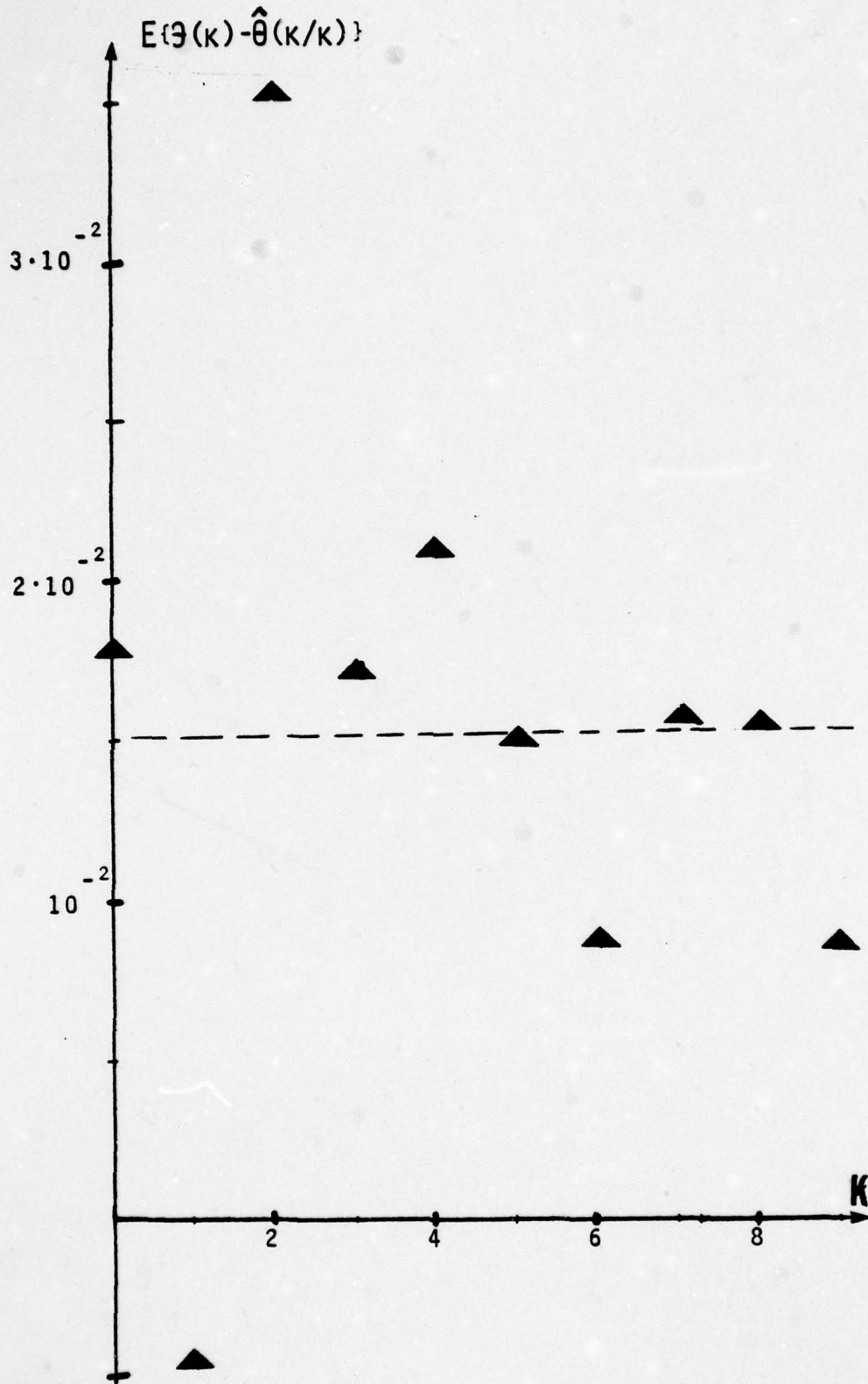

Fig. 5.2-7. The bias error.

b. Mathematical Equations

As an example we take a Gaussian p.d.f. with two unknown parameters

$\mu$  - the mean

$$\alpha^2 \triangleq \frac{1}{\sigma^2}$$

where:

$\sigma^2$  - is the variance of the process.

The p.d.f. of this process is given by

$$f_Z(Z/\alpha, \mu) = \frac{\alpha}{\sqrt{2\pi}} \exp\left\{-\frac{1}{2}\alpha^2(Z-\mu)^2\right\} \quad (5.2-13)$$

Let's define the parameters:

$$\tilde{\theta} = \begin{bmatrix} \theta_1 \\ \theta_2 \end{bmatrix} \triangleq \begin{bmatrix} \mu \\ \alpha \end{bmatrix}$$

$$\hat{\tilde{\theta}} \triangleq \begin{bmatrix} \hat{\mu} \\ \hat{\alpha} \end{bmatrix} = \begin{bmatrix} \hat{\theta}_1 \\ \hat{\theta}_2 \end{bmatrix} = \begin{bmatrix} Y_1 \\ Y_2 \end{bmatrix} \quad (5.2-14)$$

Define a new variable related to the real parameter ( $\alpha$  and  $\mu$ ) and the estimated parameters ( $\hat{\theta}_1, \hat{\theta}_2$ ):

$$\beta^2 \triangleq \hat{\theta}_2^2 + \alpha^2$$

$$\gamma \triangleq \frac{1}{\beta^2} [\hat{\theta}_2^2 \hat{\theta}_1 + \alpha^2 \mu]$$

$$c^2 \triangleq [\hat{\theta}_2^2 \hat{\theta}_1^2 + \alpha^2 \mu^2] \quad (5.2-15)$$

$$b \triangleq c^2 - \gamma^2 \cdot \beta^2$$

$$\begin{aligned} d &\triangleq 1 - \frac{\hat{\theta}_2^2}{\beta^2} - \hat{\theta}_2^2 \gamma^2 + 2\gamma \hat{\theta}_1 \hat{\theta}_2^2 - \hat{\theta}_1^2 \hat{\theta}_2^2 \\ &= 1 - \frac{\hat{\theta}_2^2}{\beta^2} - \hat{\theta}_2^2 (\gamma - \hat{\theta}_1)^2 \end{aligned}$$

The equation of the probability filters follows according to (5.2-1a,b,c) as:

$$\frac{\partial f_Z}{\partial Y_1} = \frac{Y_2^3}{\sqrt{2\pi}} (z - Y_1) \exp\{-\frac{1}{2} Y_2^2 (z - Y_1)^2\}$$

$$\frac{\partial f_Z}{\partial Y_2} = \frac{1}{\sqrt{2\pi}} [1 - Y_2^2 (z - Y_1)^2] \exp\{-\frac{1}{2} Y_2^2 (z - Y_1)^2\}$$

Thus from (5.2-1b) we get for this case:

$$\underline{f}_E(\underline{Y}, \underline{\theta}) \triangleq \begin{bmatrix} \left[ \frac{\partial I}{\partial Y_1} \right]_E \\ \left[ \frac{\partial I}{\partial Y_2} \right]_E \end{bmatrix} = \begin{bmatrix} -\frac{1}{N} \sum_{i=1}^N \frac{\partial f_Z(Z(i) | Y_1, Y_2)}{Y_1} \\ \frac{1}{4\sqrt{\pi}} - \frac{1}{N} \sum_{i=1}^N \frac{\partial f_Z(Z(i) | Y_1, Y_2)}{\partial Y_2} \end{bmatrix} \quad (5.2-16)$$

The theoretical  $\partial I / \partial Y_1$  comes out to be, according to (5.2-1a):

$$\underline{f}_T(\underline{Y}, \underline{\theta}) \triangleq \begin{bmatrix} \left[ \frac{\partial I}{\partial Y_1} \right]_T \\ \left[ \frac{\partial I}{\partial Y_2} \right]_T \end{bmatrix} = \begin{bmatrix} -\frac{Y_2^3}{\sqrt{2\pi}} \frac{\alpha}{\beta} \exp\left[-\frac{1}{2}b\right] \cdot [\gamma - Y_1] \\ \frac{1}{4\sqrt{\pi}} - \frac{\alpha}{\sqrt{2\pi} \cdot \beta} \exp\left[-\frac{1}{2}b\right] \cdot d \end{bmatrix} \quad (5.2-17)$$

We cannot find an iterative formula relating  $\alpha_{j+1}$ ,  $\mu_{j+1}$  to  $\alpha_j$  and  $\mu_j$  directly. However, we still need to be able to solve the relationship

$$\left. \begin{array}{l} f_t(\hat{\theta}, \underline{\theta}) = \underline{f}_E(\hat{\theta}, \underline{\theta}) \\ \underline{\theta} = \hat{\theta} \end{array} \right\} \Rightarrow \underline{f}_E(\hat{\theta}, \underline{\theta}) = 0 \quad (5.2-18)$$

Assume that we are close to the real parameters and then:

$$\hat{\theta}_1 \approx \mu$$

$$\hat{\theta}_2 \approx \alpha$$

$$\gamma \approx \mu$$

$$b \approx 0$$

$$\frac{\alpha}{\beta} \approx \frac{1}{\sqrt{2}}$$

$$d \approx 1 - \frac{\hat{\theta}_2^2}{2\alpha^2}$$

We estimate the parameters in the experimental equation as suggested in Appendix D by using a reference signal (see Fig. D-5).

Our system measures  $[\partial I / \partial Y_i]_E$ . The analytical functions  $[\partial I / \partial Y_i]_T$  are given by equation (5.2-17). Using the form of (5.2-1c), (5.2-18) leads to the approximate equations

$$\hat{\mu}_{j+1} \approx \hat{\mu}_j - \left[ \frac{\partial I}{\partial \hat{\mu}_j} \right]_E \cdot \frac{2\sqrt{\pi}}{\hat{\alpha}_j^3}$$

(5.2-20)

$$\hat{\alpha}_{j+1}^2 \approx \hat{\alpha}_j^2 \left( 1 - \left[ \frac{\partial I}{\partial \hat{\alpha}_j} \right]_E \cdot 4\sqrt{\pi} \right)$$

We see that in the limit, i.e., when  $[\partial I / \partial Y_i]_E = 0$ , we get the estimation of the parameters.

It can be seen from (5.2-17) that the sign of the error in  $\mu$  is independent of  $\hat{\alpha}_j$ , and it is dependent only on the error  $(\mu - \hat{\mu})$  itself. Consequently, the

convergence is better if  $\hat{\alpha}_j$  is fixed and  $\hat{\mu}_j$  is changed until  $[\partial I / \partial \mu_j]_E \rightarrow 0$ . Then  $\hat{\mu}_j$  and  $\hat{\alpha}_j$  are changed until  $[\partial I / \partial Y_1]_E$  and  $[\partial I / \partial Y_2]_E$  approach zero. In this case it appears that we can not use a fixed number of iterations, we have to iterate until  $[\partial I / \partial Y_i]_E \rightarrow 0$ .

### c. Open Loop Performances

In the last paragraph it has been shown that it is sufficient to treat the open loop probability filter as a measurement device and add a Kalman filter to it with measurement noise  $R(K)$  dependent on the data. We perform two experiments, in which we use the probability filter with a reference signal (see fig. (5.2-8)).

The first experiment is to show that the performance of the filter is independent of the mean,  $\theta_1 = \mu$ . The second experiment tests the influence of the variance,  $\theta_2^{-2}$  on the performance of the filter.

In each of these cases, our ensemble number is 50, and  $N = 1000$ . For reference we include the performance of a likelihood filter for competition. The results are given in Tables (5.2-4) and (5.2-5).

The first experiment (see Table 5.2-4) shows clearly that the error in the variance of  $\hat{\theta}_1$  and  $\hat{\theta}_2$  is essentially independent of  $\theta_1$ . We hold  $\theta_2$  fixed (in our case  $\theta_2 = 1.0$ ) and changed  $\theta_1$  from -50 to +50. The results for each value of  $\theta_1$  are very close.

The parameter  $\theta_1$  is chosen to be zero and  $\theta_2$  is changed from 0.01 to 100. From Table 5.2-5 we see that the variances can be expressed empirically.

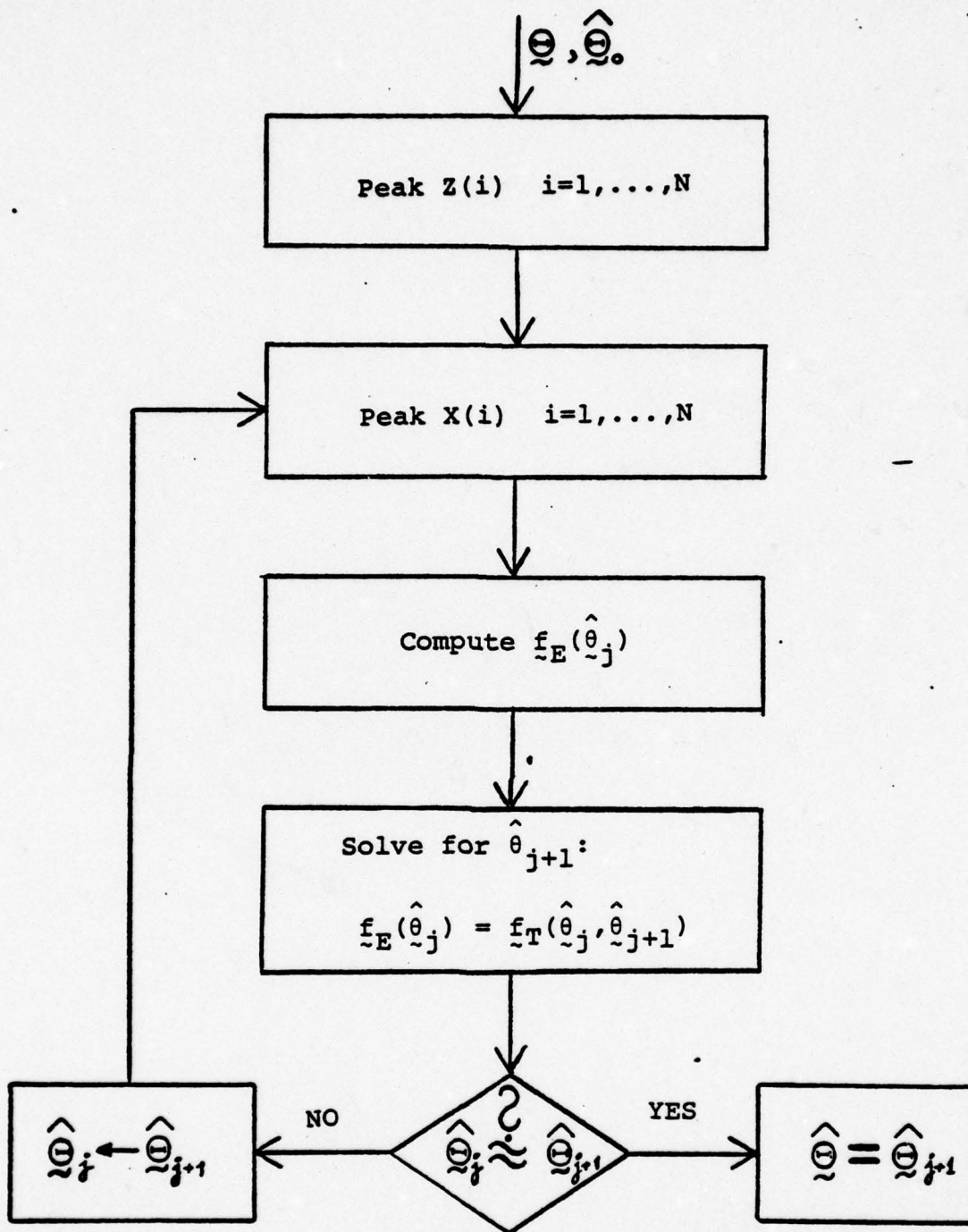

Fig. 5.2-8. Block Diagram of estimating  $\hat{\theta}$ .

Definitions for the following tables:

$$\delta = \begin{cases} p & \text{output from probability filter, } \Delta\theta_1^j \hat{A} E(\theta_1 - \hat{\theta}_1^j) \quad i = 1, 2 \\ l & \text{output from likelihood filter, } \text{VAR}(\Delta\theta_1^j) \hat{A} \text{VAR}(\theta_1 - \hat{\theta}_1^j) \quad i = 1, 2 \end{cases}$$

$$\theta_2 = 1.0$$

$\theta_1$	$\Delta\theta_1^P$	$\Delta\theta_2^P$	$\Delta\theta_1^{P*}$	$\Delta\theta_2^P$	$\text{VAR}(\Delta\theta_1^P)$	$\text{VAR}(\Delta\theta_2^P)$	$\text{VAR}(\Delta\theta_1^P)$	$\text{VAR}(\Delta\theta_2^P)$
-50	$2.3 \cdot 10^{-3}$	$-8.1 \cdot 10^{-3}$	$4 \cdot 10^{-5}$	$-4.9 \cdot 10^{-3}$	$1.7 \cdot 10^{-3}$	$1.4 \cdot 10^{-3}$	$8 \cdot 10^{-4}$	$3.5 \cdot 10^{-4}$
-10	$4 \cdot 10^{-4}$	$5.5 \cdot 10^{-3}$	$3.6 \cdot 10^{-4}$	$-2.5 \cdot 10^{-3}$	$1.5 \cdot 10^{-3}$	$1.2 \cdot 10^{-3}$	$9 \cdot 10^{-4}$	$5.8 \cdot 10^{-4}$
0	$4.7 \cdot 10^{-4}$	$-5.6 \cdot 10^{-3}$	$3.5 \cdot 10^{-4}$	$-2.2 \cdot 10^{-3}$	$1.4 \cdot 10^{-3}$	$1.2 \cdot 10^{-3}$	$9 \cdot 10^{-4}$	$5.7 \cdot 10^{-4}$
10	$2.5 \cdot 10^{-3}$	$-8.1 \cdot 10^{-3}$	$4 \cdot 10^{-5}$	$-4.9 \cdot 10^{-3}$	$1.1 \cdot 10^{-3}$	$1.4 \cdot 10^{-3}$	$8 \cdot 10^{-4}$	$3.5 \cdot 10^{-4}$
50	$6.1 \cdot 10^{-4}$	$5.6 \cdot 10^{-3}$	$1.9 \cdot 10^{-3}$	$-2.2 \cdot 10^{-3}$	$8.5 \cdot 10^{-3}$	$1.2 \cdot 10^{-3}$	$8.9 \cdot 10^{-4}$	$5.4 \cdot 10^{-4}$

Table 5.4-4. The influence of  $\theta_1$  on estimating  $\hat{\theta}_1$  and  $\hat{\theta}_2$

$$\theta_1 = 0$$

$\theta_2$	$\Delta\theta_1^P$	$\Delta\theta_2^P$	$\Delta\theta_1^{P*}$	$\Delta\theta_2^P$	$\text{VAR}(\Delta\theta_1^P)$	$\text{VAR}(\Delta\theta_2^P)$	$\text{VAR}(\Delta\theta_1^P)$	$\text{VAR}(\Delta\theta_2^P)$
0.01	0.46	$5.9 \cdot 10^{-5}$	0.11	$-1.8 \cdot 10^{-5}$	16	$1.5 \cdot 10^{-7}$	27.4	$4.7 \cdot 10^{-8}$
0.1	$4.8 \cdot 10^{-2}$	$1.9 \cdot 10^{-4}$	$1.5 \cdot 10^{-2}$	$-3 \cdot 10^{-4}$	0.13	$1.3 \cdot 10^{-5}$	0.12	$4.9 \cdot 10^{-5}$
1.	$4.7 \cdot 10^{-4}$	$-5.6 \cdot 10^{-3}$	$3.5 \cdot 10^{-4}$	$-2.2 \cdot 10^{-3}$	$1.4 \cdot 10^{-3}$	$1.2 \cdot 10^{-3}$	$9 \cdot 10^{-4}$	$5.7 \cdot 10^{-4}$
10.	$4.9 \cdot 10^{-4}$	$5.6 \cdot 10^{-2}$	$3.5 \cdot 10^{-4}$	$-2.2 \cdot 10^{-2}$	$1.4 \cdot 10^{-5}$	0.12	$9 \cdot 10^{-6}$	$5.6 \cdot 10^{-2}$
100.	$4.9 \cdot 10^{-5}$	0.56	$3.4 \cdot 10^{-5}$	-0.22	$1.4 \cdot 10^{-7}$	12.	$8.9 \cdot 10^{-8}$	5.9

Table 5.4-5. The influence of  $\theta_2$  on estimating  $\hat{\theta}_1$  and  $\hat{\theta}_2$

\* should be 0 in theory

$$\text{VAR}(\hat{\theta}_1^P) \approx 1.4 \cdot 10^{-3} / \theta_2^2$$

(5.2-21)

$$\text{VAR}(\hat{\theta}_2^P) \approx 1.3 \cdot 10^{-3} \theta_2^2$$

If we compare the results of the probability filter to the likelihood filter (Table 5.2-4,5) we see that the performances are close, but the likelihood filter gives better results.

The experimental results, which are given by formula (5.2-21), must be used when closing the loop with a Kalman filter as discussed in the last section.

We will now examine the influence of the number of samples,  $N$ , on the estimation for open loop probability filter. The number of samples has great influence on the estimation process because as the number of samples increase, the accuracy of the estimation increases. But, we have to look at the whole system, i.e.:

- The dynamics of the process generating  $Z(t)$  when the dynamics of the process are rapid, we would like to take a minimum number of samples.
- A good estimation after  $N$  samples does not mean that we cannot get a better estimation with fewer than  $N$  samples (for example  $N/10$ ). If we can filter the output of the probability filter by a Kalman-type filter we may get a better estimation. For example

$N = 5$  might be sometimes better than  $N = 1000$  if we place a Kalman-type filter after the probability filter.

Thus, the information about the influence of the number of samples is very important when we are going to design a whole system. The results of the test of the influence of the number of samples, are given in Table 5.2-6 and Figures 5.2-9 and 5.2-10. From the results we see that the variances of the estimation errors decrease almost inversely (except for  $N = 2$ ) with the number of samples. From the results it seems that the variances of the probability and likelihood filters decrease almost inversely with the number of samples. The likelihood filter (except at very small  $N$ ) gives results for most of the cases better than the probability filter.

d. Estimation of Parameter in Case of p.d.f.  
Not Known Exactly

As was discussed in Appendix D, by having a reference signal we can estimate parameters even if we have only an approximation for the p.d.f. (See equation D-12b.)

In this section we would like to show how this concept works. We take at first a Gaussian process including a limiter, which is very common in any practical measurement. We want to estimate the parameters with a minimum influence of the accuracy of the assumed p.d.f. We test this case with the probability filter with reference signals, and we compare it to the likelihood filter. The block diagram of the process is given in Fig. 5.2-11.

N	$\Delta\theta_1^P$	$\Delta\theta_2^P$	$\Delta\theta_1^\rho$	$\Delta\theta_2^\rho$	$\text{VAR}(\Delta\theta_1^P)$	$\text{VAR}(\Delta\theta_2^P)$	$\text{VAR}(\Delta\theta_1^\rho)$	$\text{VAR}(\Delta\theta_2^\rho)$
2	$-2.6 \cdot 10^{-2}$	-3.0	0.1	-4.0	0.52	32.7	0.58	43.1
5	$-8.6 \cdot 10^{-3}$	-1.1	-5.2	-0.37	0.34	0.78	0.17	0.20
10	$-2.9 \cdot 10^{-2}$	-0.41	$-3.9 \cdot 10^{-2}$	-0.18	0.12	0.71	$9.7 \cdot 10^{-2}$	$8.4 \cdot 10^{-2}$
100	$-1.5 \cdot 10^{-2}$	$-4.2 \cdot 10^{-2}$	$-1.5 \cdot 10^{-2}$	$-3.3 \cdot 10^{-2}$	$1.5 \cdot 10^{-2}$	$1.2 \cdot 10^{-2}$	$1.3 \cdot 10^{-2}$	$6.6 \cdot 10^{-3}$
1000	$4.7 \cdot 10^{-6}$	$-5.6 \cdot 10^{-3}$	$3.5 \cdot 10^{-3}$	$-2.2 \cdot 10^{-3}$	$1.4 \cdot 10^{-3}$	$1.2 \cdot 10^{-3}$	$9 \cdot 10^{-4}$	$5.7 \cdot 10^{-4}$
5000	$4.2 \cdot 10^{-3}$	$1.1 \cdot 10^{-3}$	$6.8 \cdot 10^{-5}$	$-3.6 \cdot 10^{-5}$	$2.6 \cdot 10^{-4}$	$2.5 \cdot 10^{-4}$	$2.3 \cdot 10^{-4}$	$1.3 \cdot 10^{-4}$

$$\theta_1 = 0 \quad \theta_2 = 1.0$$

Table 5.2-6 The influence of the number of samples (N) to the performances of the filters

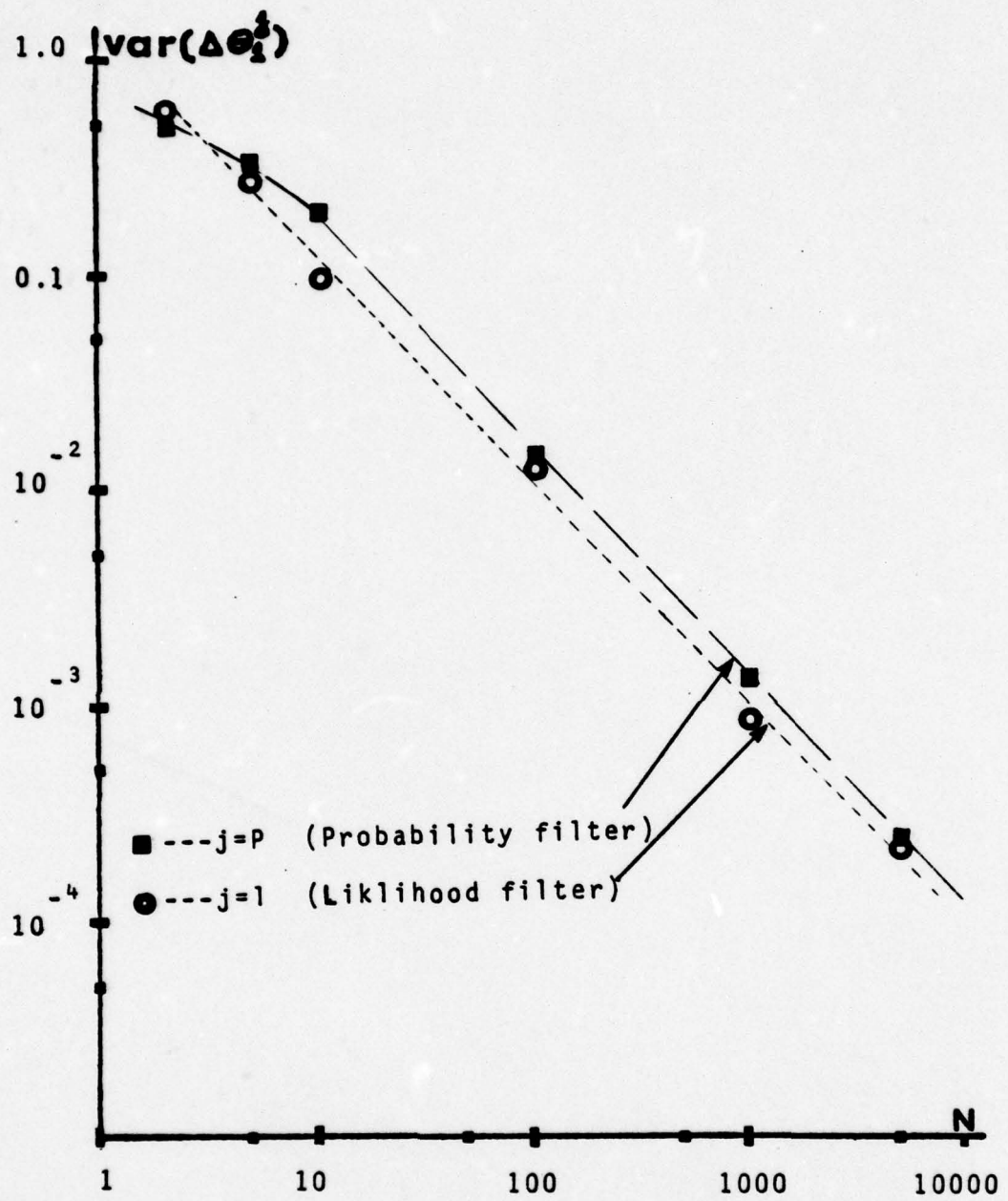

Fig. 5.2-9. The variance of  $\theta_1$  as a function of the sample's number.

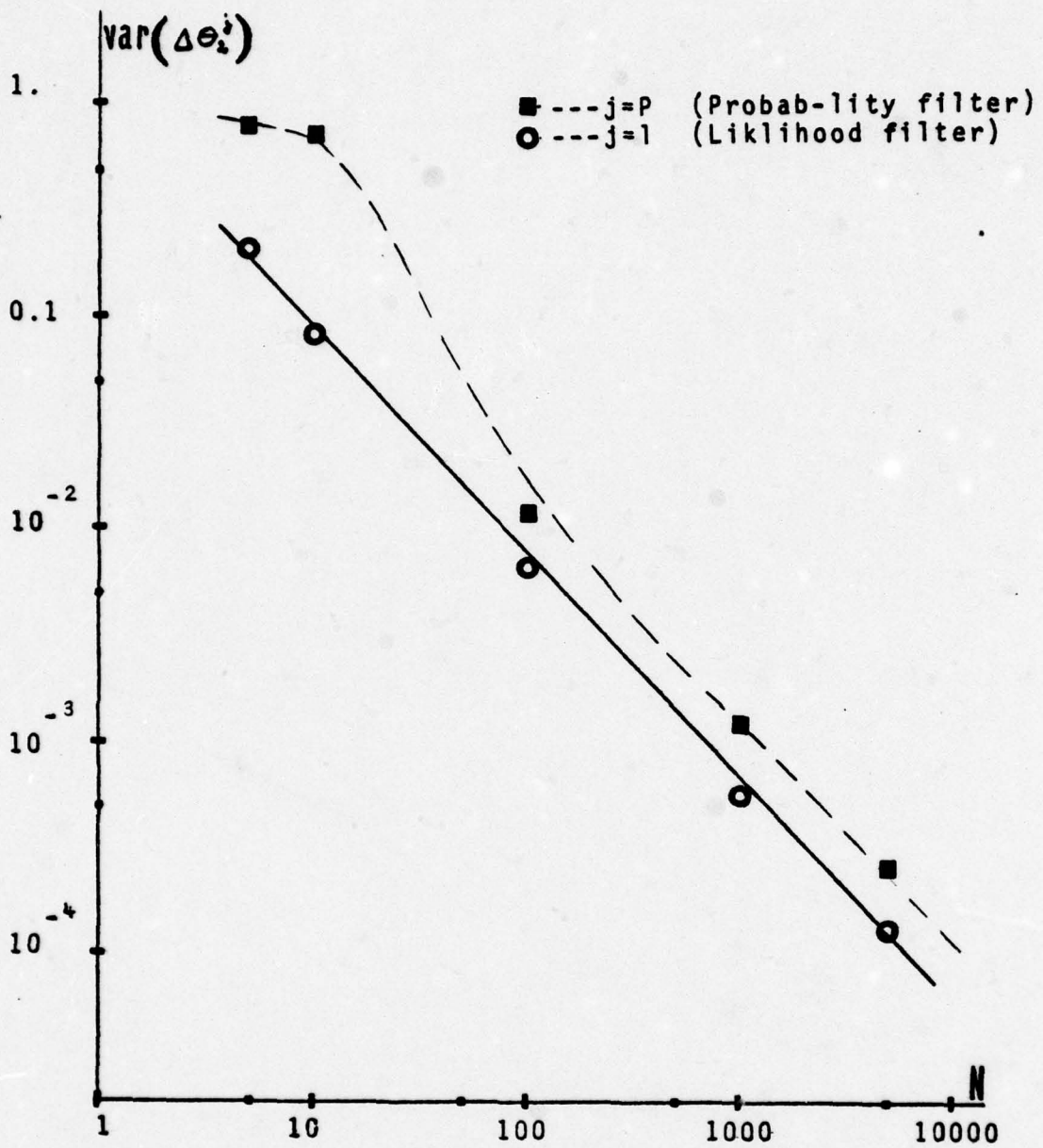

Fig. 5.2-10. The variance of  $\theta_2$  as a function of the sample's number.

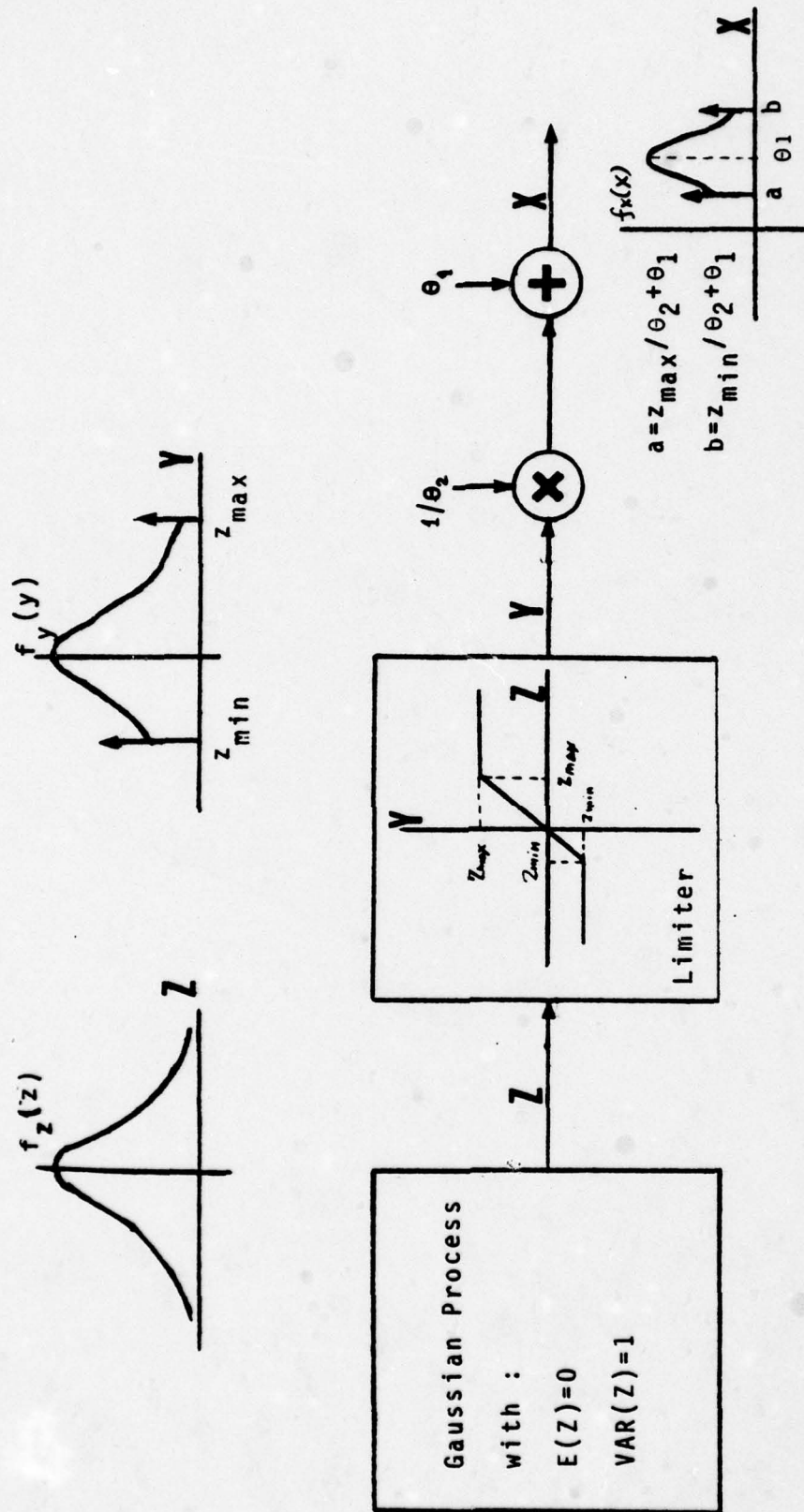

Fig. 5,2-11. The block diagram of the process with limiter

For the probability filter the reference signal is taken to be a limited Gaussian signal and the assumed p.d.f. is Gaussian. For likelihood filter the assumed p.d.f. is taken to be Gaussian also.

We test first the case of a symmetrical limiter, i.e.,  $|z_{\min}| = z_{\max}$ . The mean of the output is not influenced by the limiter. The estimation of  $\theta_2$  is influenced by the limiter. The bias error of  $\theta_2$  is strongly influenced by the limiter. The following parameters are taken for this test.

# of samples (N) = 100 ;

# of ensemble members = 100 ;

From the first simulation (see Fig. 5.2-12) we can conclude that:

- (i) The probability filter is much better than the likelihood filter when  $z_{\max} < 3$ ; for  $z_{\max} \geq 3$  the likelihood filter becomes a better filter than the probability filter.
- (ii) The bias error of the likelihood filter depends very much on the knowledge of the p.d.f., while for the probability filter error it is almost constant.

The second simulation (with a non symmetrical limiter is performed), i.e.,  $|z_{\min}| \neq z_{\max}$ . We choose  $z_{\min} = -1$ , and we change  $z_{\max}$ . The unsymmetrical limiter influences the

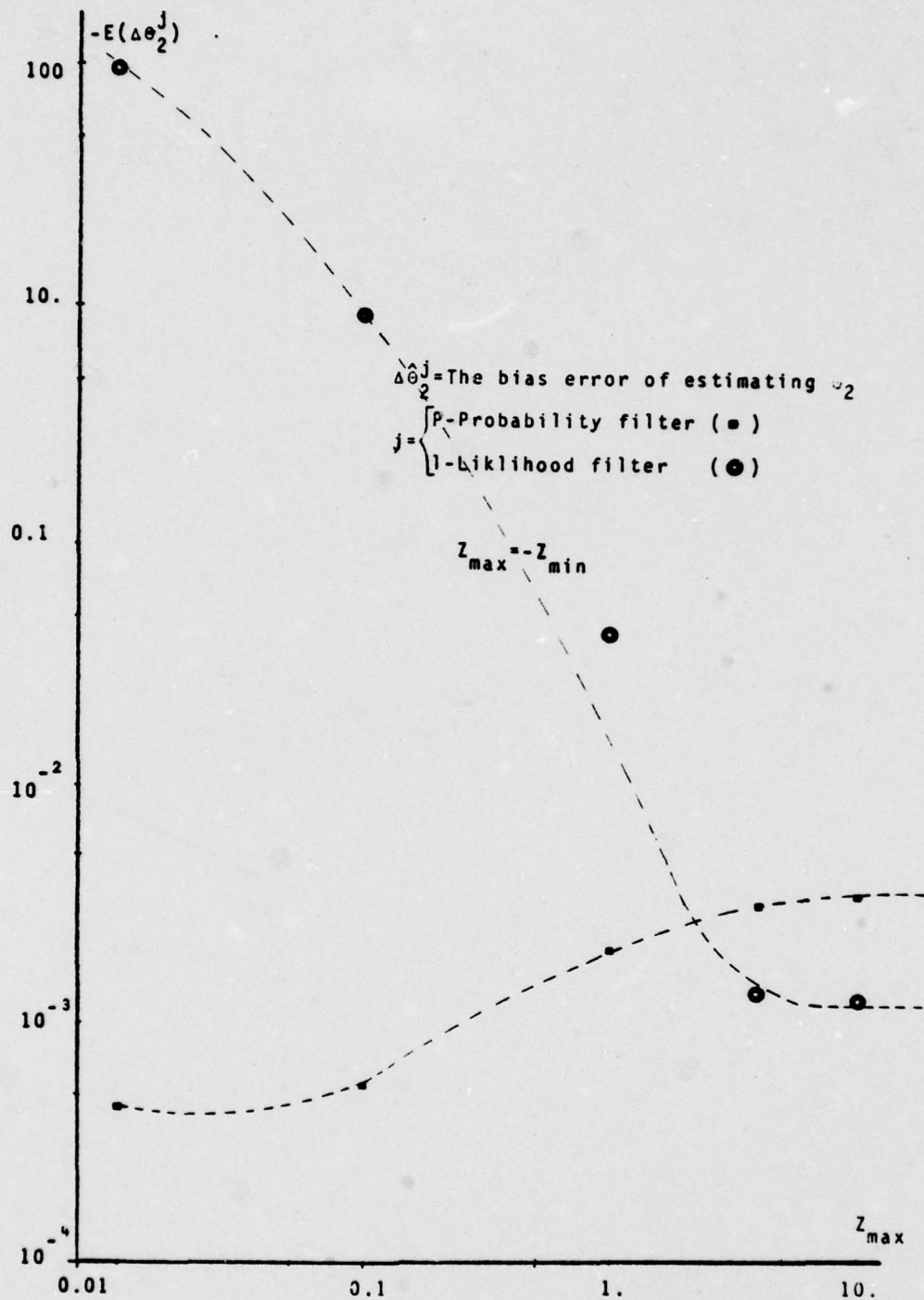

Fig. 5.2-12. The bias error of  $\theta_2$  in case of symmetrical limiter.

TABLE 5.2-7

THE INFLUENCE OF NON-SYMMETRICAL LIMIT  
ON ESTIMATING THE PARAMETERS

$z_{\max}$	$\Delta\theta_1^p$	$\Delta\theta_2^p$	$\Delta\theta_1^l$	$\Delta\theta_2^l$
0	$5.5 \cdot 10^{-3}$	$-1.3 \cdot 10^{-2}$	0.32	-1.5
0.01	$5.6 \cdot 10^{-3}$	$-1.4 \cdot 10^{-2}$	0.31	-1.5
0.5	$1.1 \cdot 10^{-3}$	$-1.3 \cdot 10^{-2}$	0.11	-0.74
1	$3.8 \cdot 10^{-3}$	$2.4 \cdot 10^{-3}$	$-2 \cdot 10^{-2}$	-0.41
5	$1.4 \cdot 10^{-2}$	$-4.1 \cdot 10^{-2}$	$-7.2 \cdot 10^{-2}$	-0.18
10	$-6.7 \cdot 10^{-4}$	$-7.6 \cdot 10^{-3}$	$-9.0 \cdot 10^{-2}$	-0.16

$$z_{\min} = -1$$

variances and the means, so we have to check the bias error of estimating  $\theta_1$  and  $\theta_2$ . The results are given in Table 7.2-7. The results show that the bias errors of the probability filter are influenced weakly by the p.d.f. while for the likelihood filter there is a great dependence upon the knowledge of the p.d.f.

It should be mentioned that the likelihood filter used for comparison here is a "straw man" in the sense that the probability filter is given the correct class of p.d.f.'s (indirectly through the reference signal), whereas the likelihood filter is not. In this example, one could design a likelihood filter using the correct class of p.d.f.'s that would probably outperform the probability filter. However, our point is that the probability filter is robust (in this example - further work is in order) with respect to errors in establishing the class of p.d.f.'s used for gradient computations when a reference signal is available. In practice, the choice between filter types would depend on whether the correct class of p.d.f.'s can be well approximated (likelihood filter) or not (probability filter) by simple analytic expressions.

##### 5. Conclusion of the Probability Filter Simulations

After the simulations we conclude the following:

- a. It has been proven that the probability filter can be implemented quite easily.
- b. The performance of the probability filter is (in our example) not sensitive to errors in

estimating the form of the p.d.f.  $f_Z(Z|\theta)$  when a reference signal is available.

- c. The performances of the filter when the p.d.f. is known exactly, is of the same order of magnitude compared to the likelihood filter, but gives worse performance most of the time.
- d. In the target/chaff problem we do not know the exact p.d.f. because there are several types of chaff and targets. It is quite easy to provide a reference signal for the probability filter which will fit to the exact p.d.f. Thus the probability filter may be found to be the practical solution. Further investigation is needed.

## VI. SUMMARY AND CONCLUSION

In this research we tried to solve a realistic and practical problem of separation of time signals when they have almost the same power spectrum. As an example, we took the chaff-target problem in tracking radar where Doppler separation is impossible. We started with a discussion of the background of the problem and developed two possible solutions.

- a. The M.K.F. with antenna modification. This is one solution to the problem in the case of maximum information available (for example in the case of monopulse radar with phase detector).
- b. The probability filter. This is one possibility of the solution to the problem in case that minimum information is given (in the case of conical scan radar or lobe switching).

To demonstrate our solution to the problem we have proven by simulations that the two main filters, the M.K.F. and the probability filters work as expected.

The following items remain to be investigated as an extension of the work.

- a. The complete solution in case of C.S. and L.S.
- b. The optimum number of samples (N) for the probability filter as a function of the dynamics of the signal process.

c. The probability filter extended to nonergodic processes.

## APPENDIX A

### MODIFIED KALMAN FILTER FOR THE CASE THAT THE MEASUREMENT COMES FROM TWO DIFFERENT SOURCES

#### 1. Introduction

In many cases we have to filter data which is not the regular data assumed by the Kalman filter. The Kalman filter is well established and sometimes it is convenient to modify the problem such that it will fit the Kalman filter, so we will have a modified Kalman filter. In our case (see Chapter IV) such a problem arises. The problem can be described briefly as follows (refer to Fig. A-1): we have a regular process described by (F-2) which gives us the output vector  $\underline{y}(K)$ .  $\underline{y}(K)$  can be split into two vectors ( $\underline{y}^{(1)}(K)$  and  $\underline{y}^{(2)}(K)$ ):

$$\underline{y}(K) \triangleq \begin{bmatrix} \underline{y}^{(1)}(K) \\ \hline \underline{y}^{(2)}(K) \end{bmatrix}$$

where  $\underline{y}^{(1)}$  and  $\underline{y}^{(2)}$  are vectors of the same dimension.

The vectors are transferred through a random process, which switches between them. After the switching block we get our measurement vector,  $\underline{z}(K)$ . The vector  $\underline{z}(K)$  can be equal to one of the two possibilities:

$$\underline{z}(K) = \begin{bmatrix} \underline{y}^{(1)}(K) \\ \hline \underline{y}^{(2)}(K) \end{bmatrix}$$

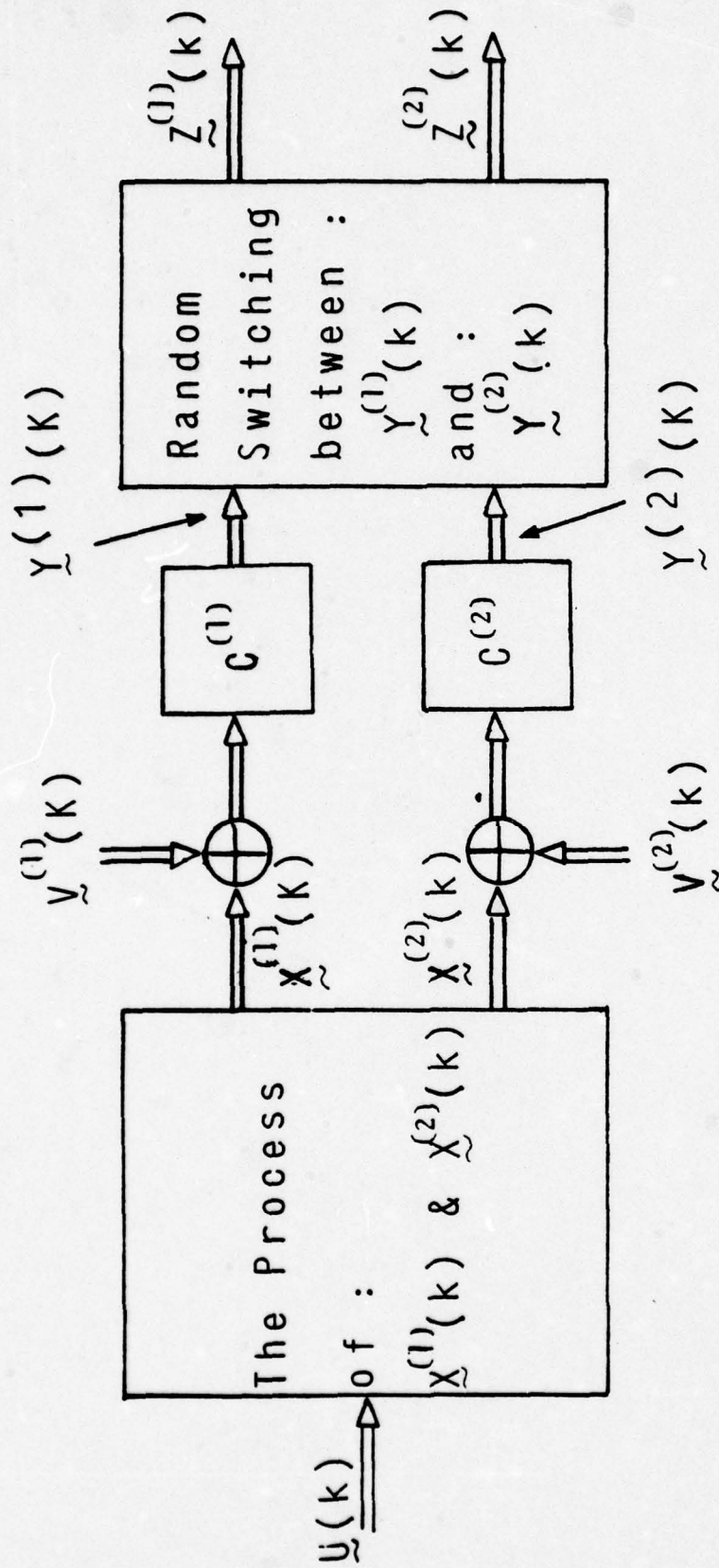

Figure A-1. The measurement process.

or:

$$\tilde{z}(K) = \begin{bmatrix} \tilde{y}^{(2)}(K) \\ \text{-----} \\ \tilde{y}^{(1)}(K) \end{bmatrix}$$

The problem statement is: given the measurement  $\tilde{z}(1), \dots, \tilde{z}(n)$  find the state vector  $X(n)$ .

Four papers deal with a similar problem [26,27,28,29]. The first two papers cannot be implemented straightforward because both of them formulate the problem in a different way. The first one [26] deals with multi-target measurements giving information about the location of each target. The system must identify the type of the target and estimate its position which is a more general problem than ours, because we assume that we know the nature of the targets.

The second and third references [27,28] deal with tracking in a cluttered environment. This could be adapted for our problem (by treating the clutter as chaff) but the assumption is that the undesirable returns occur completely at random which is not the case in our problem. There is no underlying dynamical process from which the returns are generated. Hence, no prediction from past data can be made on the location, nature or number of these returns at the next measurement time.

The last reference [29] is close to our problem but uses a different starting point. It does not give the optimum filter, which is known to be:

$$\hat{\underline{x}}(K|K) = \int_{-\infty}^{\infty} \underline{x} f(\underline{x} | \underline{z}^{(K)}) d\underline{x}$$

(for minimum variance estimates, see Appendix F). The vector  $\underline{z}^{(K)}$  is all the measured data up to time K. The p.d.f.'s  $f(\underline{x} | \underline{z}^{(K)})$  are not Gaussian, which makes the evaluation of  $\hat{\underline{x}}(K|K)$  very difficult to implement. It is extremely difficult to implement on a computer, since the p.d.f. is conditioned on all available measurement data. Thus [29] uses approximate p.d.f.'s. Our goal is to develop a filter similar to the Kalman. In order to achieve this we use:

- A selection block which transforms the measured data for input to a Kalman like filter.
- The assumption that all the p.d.f.'s are Gaussian (like in [29]).

Refer to Fig. A-2: we try to reverse the switching in the data in the first block, by selecting one from the two possibilities of  $\underline{z}^{(K)}$ . Thus after this block if our selection was correct we have the correct input to the Kalman filter. In a regular Kalman filter (R.K.F.) the input components  $\underline{z}^{(1)}(K)$  and  $\underline{z}^{(2)}(K)$  are not switched. Hence in our case if we made an error in the selection the output is biased.

In our problem we have a positive probability to select a wrong combination of  $\underline{z}^{(1)}(K)$  and  $\underline{z}^{(2)}(K)$ . We shall modify the R.K.F. so that it will be able to handle this error. The next block is a modified Kalman filter (M.K.F.).

This leads to a form like a Kalman filter but with modified gain and covariance matrices. In the R.K.F. we have two types of estimated states.

- One is  $\hat{X}(K|K)$  which is called the update estimated state. This is the optimal estimation of  $X(K)$  taking into account all the observations so far (i.e., at times up to and including  $K$ ).
- The second estimated vector is  $\hat{X}(K|K-1)$ , which is the optimal estimation of the states given all the observations up to the last measurement (i.e., the observations at times up to and including  $K-1$ ). This vector is called the predicted estimated states.

The M.K.F. has similar types of estimated states, an update estimated state and a predicted estimated state.

Intuitively we can say that:

- If we trust our new measurement, we can use the update estimated state.
- If we do not trust our new measurement, we have to use the predicted estimated state.
- If it is in between, the output must be weighted somehow between the two estimated states.
- The weighting depends on the probability of a correct solution.
- The estimated states are not optimal, in the sense of minimum variance of error, because of our assumption that the p.d.f.'s are Gaussian.

## 2. Modified Kalman Filter

### Assumption

- (i) We have two separate, independent sources of states with a given dynamic:

$$\tilde{x}^{(1)}(K+1) = \phi^{(1)} \tilde{x}^{(1)}(K) + \Delta^{(1)} \underline{u}(K) + \tilde{w}^{(1)}(K) \quad (\text{A-1})$$

$$\tilde{x}^{(2)}(K+1) = \phi^{(2)} \tilde{x}^{(2)}(K) + \Delta^{(2)} \underline{u}(K) + \tilde{w}^{(2)}(K)$$

- (ii) The measurements are given by

$$\tilde{z}(K) = L(K) [C^{(1)} \quad C^{(2)}] \begin{bmatrix} \tilde{x}^{(1)}(K) \\ \tilde{x}^{(2)}(K) \end{bmatrix} + \tilde{v}(K) \quad (\text{A-1a})$$

$$L(K) = \begin{cases} \begin{bmatrix} \bar{I} & 0 \\ 0 & I \end{bmatrix} \triangleq L_1 & \text{if } H_1 \\ \begin{bmatrix} 0 & \bar{I} \\ I & 0 \end{bmatrix} \triangleq L_2 & \text{if } H_2 \end{cases} \quad (\text{A-1b})$$

- (iii) The statistics of the random variables involved here are (assume all are Gaussian processes):

$$E[\tilde{v}(K)] = \underline{0} \quad \forall K$$

$$E[\tilde{v}(K) \tilde{v}^T(j)] = R(K) \delta_{Kj} \quad \forall K, j \quad (\text{A-2})$$

$$E \begin{bmatrix} \tilde{w}^{(1)}(K) \\ \tilde{w}^{(2)}(K) \end{bmatrix} = \underline{0} \quad \forall K$$

$$E[\tilde{W}(K) \cdot \tilde{W}^T(K)] = \begin{bmatrix} Q^{(1)}(K) & | & 0 \\ \hline 0 & | & Q^{(2)}(K) \end{bmatrix} \delta_{Kj}$$

$$\triangleq Q(K) \delta_{Kj} \quad \forall K, j$$

$$E \begin{bmatrix} \tilde{X}^{(1)}(0) \\ \hline \tilde{X}^{(2)}(0) \end{bmatrix} = \bar{\tilde{X}}_0$$

$$\text{COVAR} \begin{bmatrix} \tilde{X}^{(1)}(0) \\ \hline \tilde{X}^{(2)}(0) \end{bmatrix} = M$$

$$E[\tilde{X}(0) \cdot \tilde{V}^T(K)] = 0 \quad \forall K$$

$$E[\tilde{X}(0) \cdot \tilde{W}^T(K)] = 0 \quad \forall K \geq 0$$

$$\text{Prob}(H_1) = \text{Prob}(H_2) = \frac{1}{2}$$

No correlation exists between  $H(k)$  at time  $K$  to  $H(j)$  at time  $j$  for all  $K \neq j$ . In other words, there is no a priori information about the switching between  $H_1$  and  $H_2$ .

For convenience we define:

$$\tilde{x}(K) \triangleq \begin{bmatrix} \tilde{x}^{(1)}(K) \\ \text{-----} \\ \tilde{x}^{(2)}(K) \end{bmatrix}$$

$$\phi \triangleq \begin{bmatrix} \phi^{(1)} & | & 0 \\ \text{-----} & & \\ 0 & | & \phi^{(2)} \end{bmatrix}$$

$$\Delta \triangleq \begin{bmatrix} \Delta^{(1)} \\ \text{-----} \\ \Delta^{(2)} \end{bmatrix}$$

(A-2a)

$$\tilde{w}(K) \triangleq \begin{bmatrix} \tilde{w}^{(1)}(K) \\ \text{-----} \\ \tilde{w}^{(2)}(K) \end{bmatrix}$$

### Solution

We would like to have a sequential estimator because we like to estimate in real time with minimum delay. The non-sequential estimator (Bayesian approach) will be more accurate (i.e., with minimum variance error) but much more complicated, needs more storage, and has delayed output. For these reasons we will restrict ourselves to sequential estimators. Also, we will use a linear estimator. Because

the Kalman-like filter is linear, and we have to store only the last information about our estimation, we will build our estimator in two steps - the first one will be a selection block and the second one will be a modified Kalman filter. Because the Kalman filter is optimal for second order statistics and is a linear estimator, the only thing that we have to store is the previous values of the (i) Covariance matrices and (ii) Predicted state.

The modified Kalman filter has two main blocks (see Fig. A-2):

a. The Selection Block.

In this block we make the decision  $H = H_1$  or  $H_2$ . Let's define

$$\begin{aligned} \tilde{y}^{(1)} &\triangleq C^{(1)} \tilde{x}^{(1)} \\ \tilde{y}^{(2)} &\triangleq C^{(2)} \tilde{x}^{(2)} \end{aligned} \tag{A-3}$$

By this definition we can write:

$$\tilde{z}(K) = \begin{cases} \begin{bmatrix} \tilde{y}^{(1)} \\ \text{---} \\ \tilde{y}^{(2)} \end{bmatrix} & \text{if } H_1 \text{ is true} \\ \begin{bmatrix} \tilde{y}^{(2)} \\ \text{---} \\ \tilde{y}^{(1)} \end{bmatrix} & \text{if } H_2 \text{ is true} \end{cases}$$

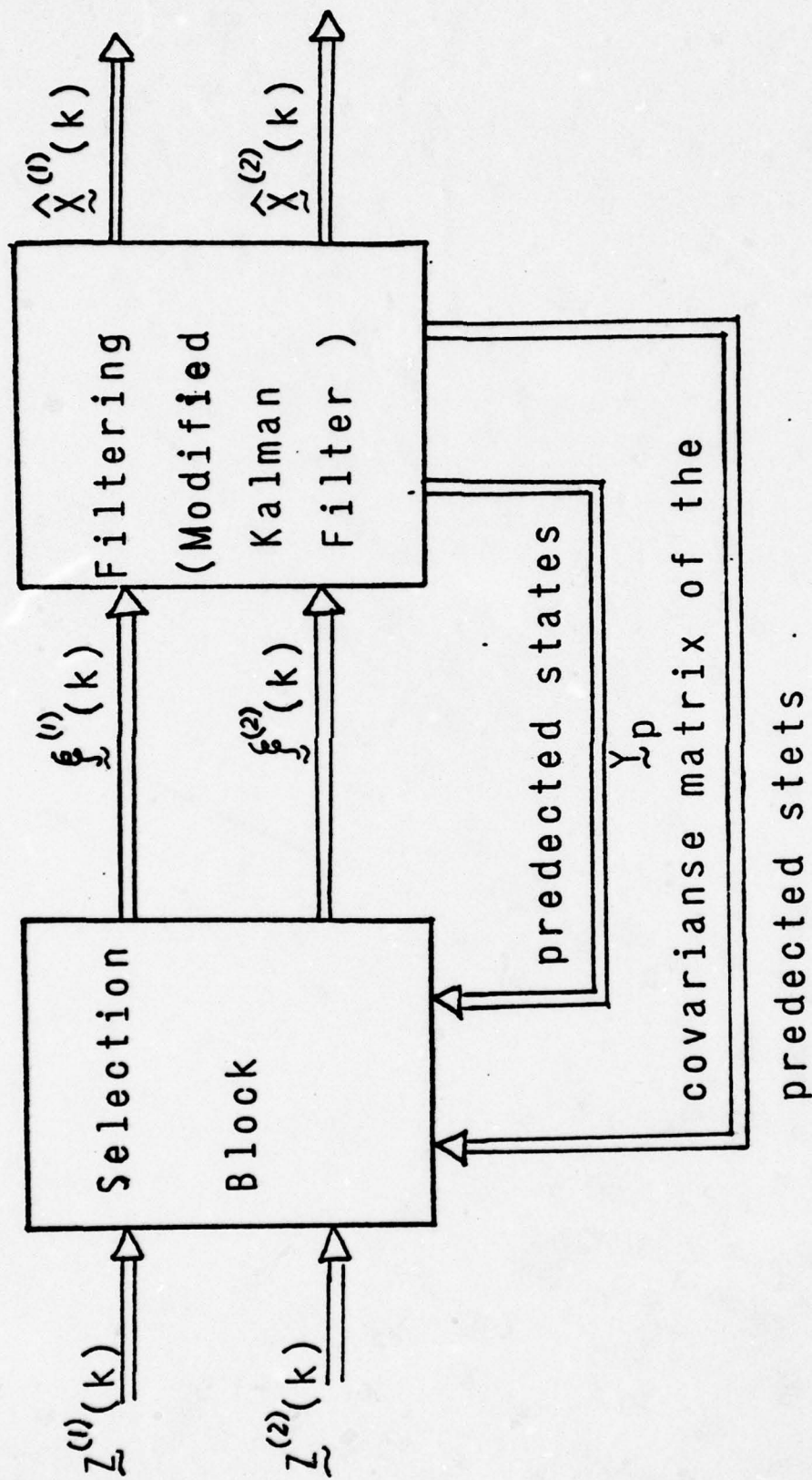

Fig. A-2. Block diagram of the modified Kalman filter.

(see Fig. A-1).

$$\tilde{z}(K) \triangleq \begin{bmatrix} \tilde{z}^{(1)}(K) \\ \text{-----} \\ \tilde{z}^{(2)}(K) \end{bmatrix}$$

When the processing continues we have the predicted states (measured state) with the covariances of the error associated with the predicted states (measured state). Then by the likelihood ratio we can decide  $H_1$  or  $H_2$ .

$$L \triangleq \frac{f(\tilde{z}^{(1)}, \tilde{z}^{(2)} | H_1)}{f(\tilde{z}^{(1)}, \tilde{z}^{(2)} | H_2)} \quad (A-4)$$

Thus the decision is:

$$\begin{array}{ll} L > 1 & \text{decide } H_1 \\ L < 1 & \text{decide } H_2 \end{array} \quad (A-5)$$

By the knowledge of the covariance matrix, and assumed Gaussian distribution of the state,  $L$  can be computed.

The predicted measurement is determined in the filter procedure:

$$\Lambda(K) = \text{the covariance error of the predicted measurement, } Y(K|K-1) \quad (A-6)$$

$$\underline{y}_p(k) \triangleq \underline{y}(k|k-1) = \begin{bmatrix} z_p^{(1)}(k) \\ \text{-----} \\ z_p^{(2)}(k) \end{bmatrix}; \text{ the predicted measurement}$$

By defining

$$\underline{r}_1(k) \triangleq \underline{y}_p(k) - \underline{t}_1(k)$$

$$\underline{r}_2(k) \triangleq \underline{y}_p(k) - \underline{t}_2(k)$$

(A-7)

$$\underline{t}_1(k) \triangleq \begin{bmatrix} z^{(1)} \\ \text{-----} \\ z^{(2)} \end{bmatrix}$$

$$\underline{t}_2(k) \triangleq \begin{bmatrix} z^{(2)} \\ \text{-----} \\ z^{(1)} \end{bmatrix}$$

$$L_i(k) = \underline{r}_i^T(k) \cdot \Lambda^{-1}(k) \cdot \underline{r}_i(k) \quad i = 1, 2$$

Thus:

$$f(\underline{z}^{(1)}, \underline{z}^{(2)} | H_i) = (2\pi)^{-m/2} |\Lambda|^{-1/2} \exp\{-\frac{1}{2} L_i(k)\}$$

m = dimension of the measurement vector.

Substituting into Eq. (A-4) we get the decision law:

$$\begin{aligned} L_1(K) < L_2(K) & \quad \text{decide } H_1 \\ L_1(K) > L_2(K) & \quad \text{decide } H_2 \end{aligned} \tag{A-8}$$

See the block diagram in Fig. A-3 for details.

b. The Filtering Block

After the decision about the measured state is made, we have now the problem of filtering the data. The filtering could be straightforward if we have high confidence that our decision was correct, which is assumed in the regular Kalman filter. In our case we are not sure if our decision was correct, and so in the filtering process, we must take this into account. Because we cannot tell if our decision was correct or not we cannot reject or accept the data, we can only "weight" the data and depend on the computed probability that our data is correct or not.

We have two possibilities:

(i) A true data available, i.e., we decide the right decision, we will call this event  $\underline{D}(K)$  - the data is desired, in sample K.

(ii) A false data available, i.e., we decide the wrong decision, we will call this event  $\underline{F}(K)$  - the data is false, in sample K.

So we can write:

$$f(\underline{X}(K) | \underline{Z}(K)) = \alpha(K) \cdot f[\underline{X}(K) | D(K), \underline{Z}(K)] + [1-\alpha(K)] f[\underline{X}(K) | F(K), \underline{Z}(K)] \quad (\text{A-9})$$

where

$$\begin{aligned} \alpha(K) &\triangleq \text{Prob}\{\text{decision } K \text{ was desired}\} \\ &= \text{Prob}\{D(K) | \underline{Z}(K)\} \end{aligned} \quad (\text{A-10})$$

Assume that  $L_2^{(K)} > L_1(K)$ . Then:

$$\begin{aligned} \alpha(K) &\triangleq P\{D(K) | \underline{Z}(K)\} = P\{H_1(K) | \underline{Z}(K)\} \\ &= \frac{f\{\underline{Z}(K) | H_1(K)\} \cdot P(H_1(K))}{f\{\underline{Z}(K) | H_1(K)\} \cdot P(H_1(K)) + f\{\underline{Z}(K) | H_2(K)\} \cdot P(H_2(K))} \end{aligned} \quad (\text{A-11})$$

Observe that:

$$P\{H_1(K)\} = P\{H_2(K)\} = \frac{1}{2}$$

Then:

$$\alpha(K) = \frac{1}{1 + \beta_i(K)} \quad i = 1, 2 \quad (\text{A-12})$$

where, in case of  $L_2(K) > L_1(K)$ :

$$\beta_1(K) \triangleq \frac{f\{\underline{Z}(K) | H_2(K)\}}{f\{\underline{Z}(K) | H_1(K)\}} = e^{-(L_2 - L_1)/2}$$

and in case of  $L_1(K) > L_2(K)$ , then:

$$\beta_2(K) \triangleq \frac{f\{\underline{Z}(K) | H_1(K)\}}{f\{\underline{Z}(K) | H_2(K)\}} = e^{-(L_1 - L_2)/2}$$

Then we can conclude that:

$$\alpha(K) = \frac{1}{1 + \beta(K)} \quad (A-13)$$

where:

$$\beta(K) \triangleq e^{-|L_1(K) - L_2(K)|/2} \quad (A-13a)$$

From Equation (A-9) we see that:

$$\begin{aligned} \hat{\tilde{X}}(K|K) &= E\{\tilde{X}|Z(K)\} = \alpha(K)E\{\tilde{X}(K)|D(K), Z(K)\} \\ &+ [1 - \alpha(K)]E\{\tilde{X}(K)|F(K), Z(K)\} \end{aligned} \quad (A-14)$$

i.e., the new estimate of the state will be weighted with the results of a filter when assuming true data, and the predicted estimate of the state (assuming false data). The question now is, what kind of filter to use here? It seems reasonable to use a modified Kalman filter, because Kalman filter is the best linear sequential filter (when only the second order statistics are given). We use here the notation "modified Kalman filter" because it is not a regular Kalman filter in the sense that the covariance matrices and the gain are data dependent (because the output is a function

of  $\alpha$ ). Furthermore, there is additional selection block which does not appear in R.K.F.

The only way not to have extremely time consuming computations is to assume that the p.d.f. is Gaussian. The Kalman filter gives us the information that is used to evaluate an approximation of the p.d.f., assuming a Gaussian distribution.

Because our gain and the covariance matrices are data dependent, we must compute them on line rather than off line.

Let's summarize the results first and then derive them:

a. The estimator is characterized by:

$$\hat{\tilde{X}}(K|K) = \hat{\tilde{X}}(K|K-1) + G_M(K) [\zeta(K) - C\hat{\tilde{X}}(K|K-1)] \quad (A-15)$$

$$\hat{\tilde{X}}(K|K-1) = \phi\hat{\tilde{X}}(K-1|K-1) + \Delta U(K-1)$$

where  $\zeta$  is the input vector after the selection.

b. The gain is given by:

$$G_M(K) = \alpha(K) G(K) \quad (A-16)$$

where

$$G(K) = P(K|K-1) C^T [C P(K|K-1) C^T + R]^{-1}$$

$G(K)$  - is the regular Kalman filter gain.

c. Update covariance error matrix, and predicted error covariance matrix:

$$P(K+1|K) = \phi \Sigma(K|K) \phi^T + Q \quad (A-17)$$

$$\begin{aligned} \Sigma(K|K) &= \alpha^2(K) P(K|K) + [1 - \alpha(K)]^2 P(K|K-1) \\ &+ 2\alpha(K) [1 - \alpha(K)] \{ [I - G_M(K)C] \phi \Sigma(K-1|K-1) \phi^T \\ &+ [I - G_M(K)C] Q \} \end{aligned}$$

where

$$P(K|K) = [I - G(K)C] P(K|K-1)$$

$P(K|K)$  = the regular Kalman filter.

d.

$$\begin{aligned} \alpha(K) &= \frac{1}{1 + \beta(K)} \\ \beta(K) &= e^{-|L_1(K) - L_2(K)|/2} \quad (A-18) \end{aligned}$$

$\alpha_1(K)$ ,  $L_2(K)$  are given by (A-7)

e. Initial conditions:

$$P(0|-1) = M \quad (A-19)$$

$$x(0|-1) = \bar{x}_0$$

f. The predicted measured error covariance matrix is given by:

$$\Lambda(K) = CP(K|K-1) C^T + R(K) \quad (A-20)$$

(See Fig. A-4 for details.)

#### Explanation and Notation

1. The differences between the Kalman filter and this filter are:

- The gains are data dependent, and so they must be computed online.
- The error covariance matrix is not the same as in the Kalman filter.
- We do not use the measured vector  $Y$  but the vector  $Z$ .

2. The Modified Gain -  $G_M$ :

In the regular Kalman filter the estimate equation of the state is given by:

$$\hat{\tilde{x}}^{(K)}(K|K) = \hat{\tilde{x}}(K|K-1) + G(K) [\zeta(K) - C\hat{\tilde{x}}(K|K-1)] \quad (A-21)$$

$$\hat{\tilde{x}}(K|K-1) = \Phi\hat{\tilde{x}}(K-1|K-1) + \Delta U(K)$$

where

$\hat{\tilde{x}}^{(K)}(K|K)$  is the update estimate state in R.K.F.

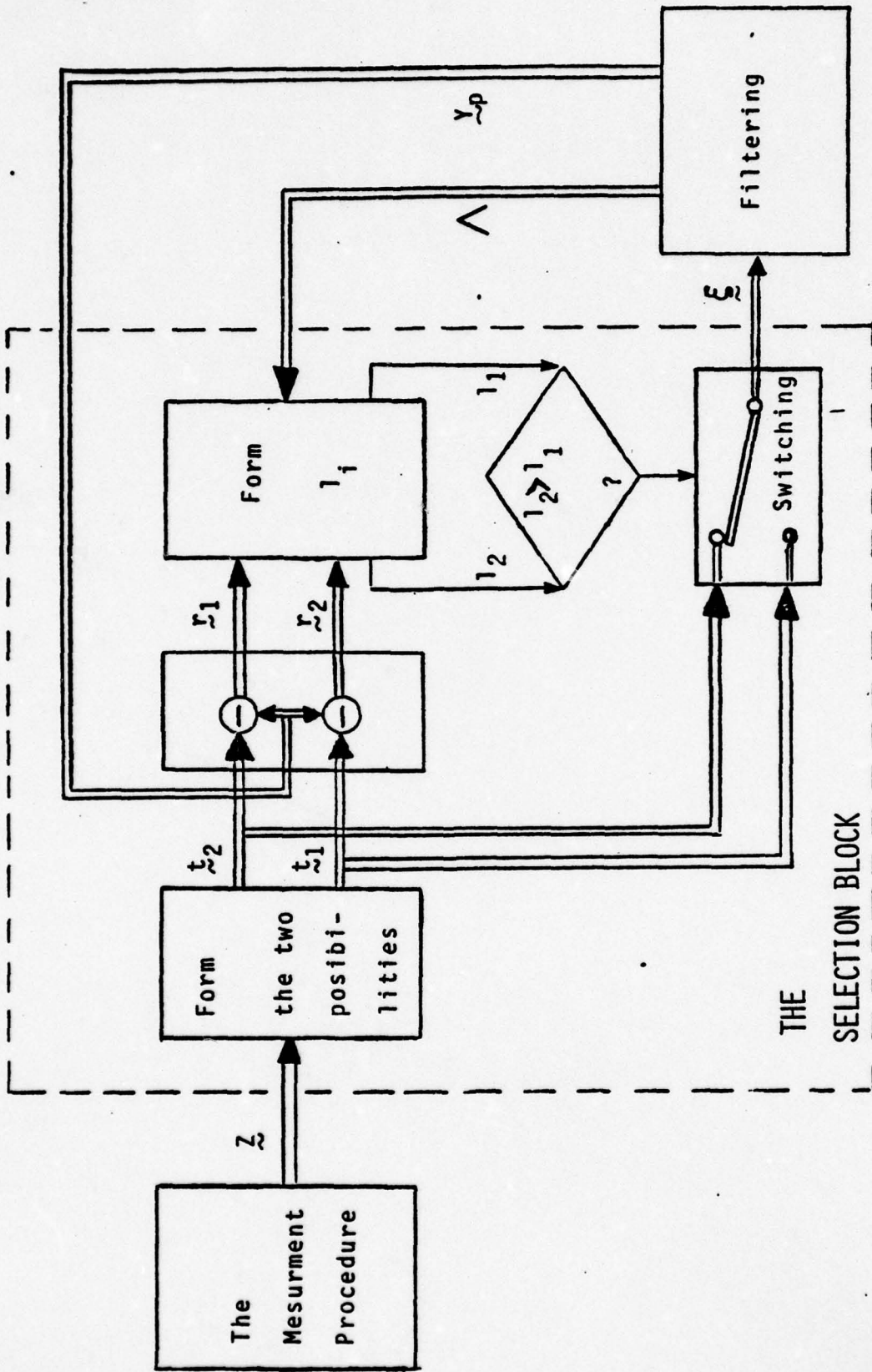

Fig. A-3. Block diagram of the selection block.

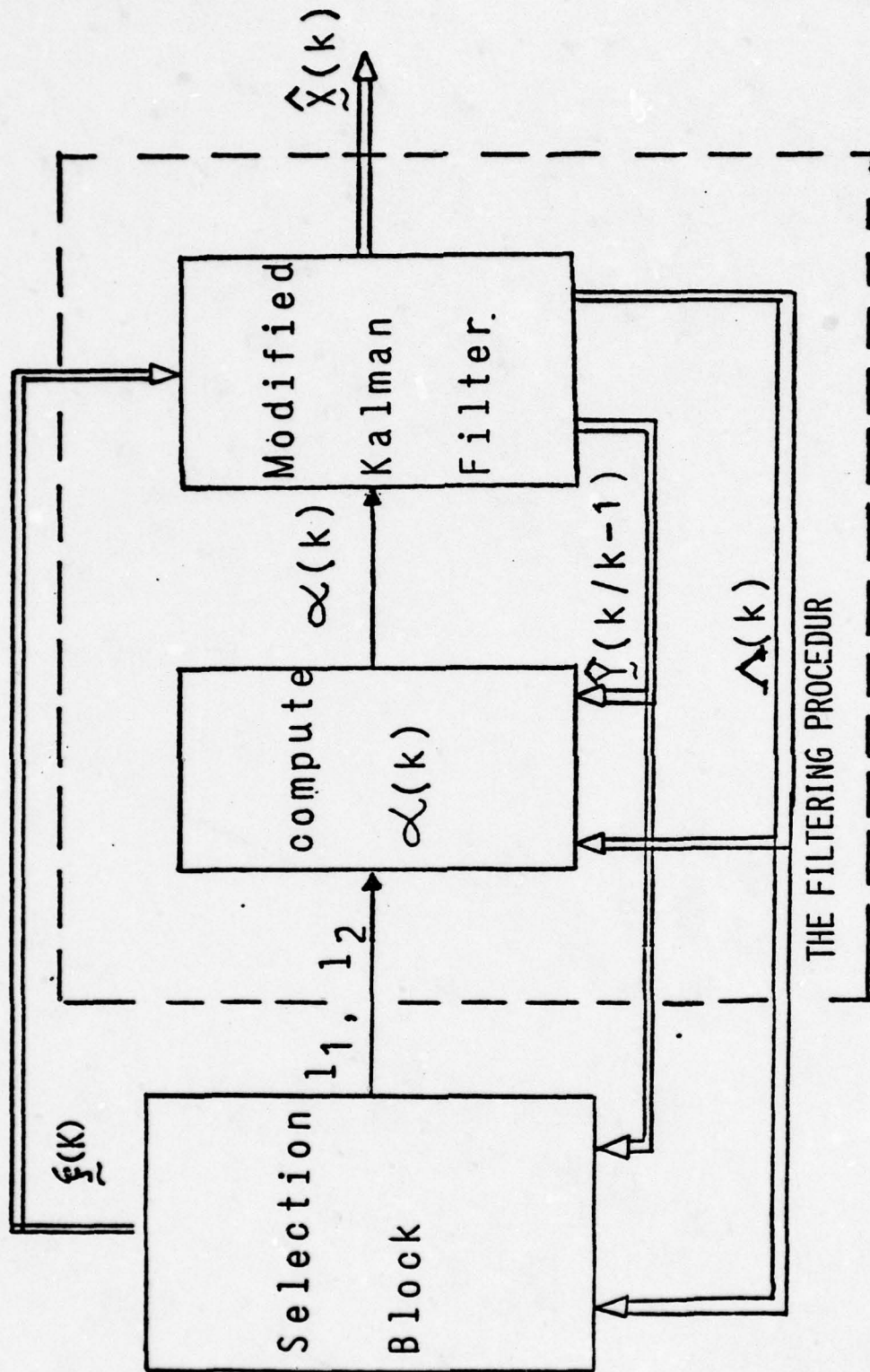

Fig. A-4. The block diagram of the filtering procedure.

In our case, when we compute the state  $\hat{\underline{X}}(K|K)$  we must take into account both the updated states assuming that our measurement is correct, and the predicted states assuming that our measured vector is not correct (A-14,15), i.e.:

$$\begin{aligned}\hat{\underline{X}}(K|K) &= \alpha(K)\hat{\underline{X}}^{(K)}(K|K) + [1 - \alpha(K)]\hat{\underline{X}}(K|K-1) \\ &= \hat{\underline{X}}(K|K-1) + \alpha(K)G(K)[\underline{z}(K) - C\hat{\underline{X}}(K|K-1)]\end{aligned}\tag{A-22}$$

Thus we see that the modified gain is  $G_M(K) = \alpha(K)G(K)$ .

### 3. Covariance matrix of the error:

The covariance matrix of the error is defined by:

$$\underline{\Sigma}(K|K) \triangleq E[\underline{e}(K|K) \cdot \underline{e}^T(K|K)]\tag{A-23}$$

And:

$$\begin{aligned}\underline{e}(K|K) &\triangleq \hat{\underline{X}}(K|K) - \underline{X}(K) \\ &= \alpha(K)\hat{\underline{X}}(K|K) + [1 - \alpha(K)]\hat{\underline{X}}(K|K-1) - \underline{X}(K)\end{aligned}$$

Substituting  $\underline{e}$  into  $\underline{\Sigma}$  we get:

$$\begin{aligned} \Sigma(K|K) &= \alpha^2(K)P(K|K) + [1 - \alpha(K)]^2P(K|K-1) \\ &\quad + 2\alpha(K)[1 - \alpha(K)]E(\tilde{e}(K|K)\tilde{e}^T(K|K-1)) \end{aligned}$$

where  $P(K|K)$ ,  $P(K|K-1)$  are the regular Kalman filter error covariance matrices. Now we have to evaluate the estimation of

$$\tilde{e}(K|K)\tilde{e}^T(K|K-1);$$

It can be shown that: [35,38]:

$$\begin{aligned} \tilde{e}(K|K) &= (I - G_M(K)C)\phi\tilde{e}(K-1|K-1) + G_M(K)V(K) \\ &\quad - [I - G_M(K)C]W(K-1) \end{aligned}$$

$$\tilde{e}(K|K-1) = \phi\tilde{e}(K-1|K-1) - W(K-1)$$

Thus:

$$\begin{aligned} \tilde{e}(K|K)\tilde{e}^T(K|K-1) &= \{[I - G_M(K)C]\phi\tilde{e}(K-1|K-1) + G_M(K)V(K) - G_M(K)V(K) \\ &\quad - [I - G_M(K)C]W(K-1)\} \{ \phi\tilde{e}(K-1|K-1) - W(K-1) \} \\ &= [I - G_M(K)C]\phi\tilde{e}(K-1|K-1)\tilde{e}^T(K-1|K-1)\phi^T \\ &\quad + G_M(K)V(K)\tilde{e}^T(K-1|K-1)\phi^T - [I - G_M(K)C]W(K-1)\tilde{e}^T(K-1|K-1)\phi^T \\ &\quad - [I - G_M(K)C]\phi\tilde{e}(K-1|K-1)W^T(K-1) - G_M(K)V(K)W^T(K-1) \\ &\quad + [I - G_M(K)C]W(K-1)W^T(K-1). \end{aligned}$$

Using the properties:

$$E\{\underline{e}(k-1|k-1) \underline{v}^T(k)\} = 0$$

$$E\{\underline{e}(k-1|k-1) \underline{w}^T(k)\} = 0$$

$$E\{\underline{w}(k-1) \underline{v}^T(k)\} = 0$$

we get

$$E\{\underline{e}(k|k) \underline{e}^T(k|k-1)\} = [I - G_M(k)C] \phi \Sigma(k-1|k-1) \phi^T + [I - G_M(k)C]Q$$

Substituting the result into the equation for  $\Sigma$  we get:

$$\begin{aligned} \Sigma(k|k) &= \alpha^2(k)P(k|k) + [1 - \alpha(k)]^2 P(k|k-1) \\ &\quad + 2\alpha(k)[1 - \alpha(k)]\{[I - G_M(k)C] \phi \Sigma(k-1|k-1) \phi^T \\ &\quad + [I - G_M(k)C]Q\}. \end{aligned}$$

4. The predicted measured error covariance matrix  $\Lambda(k)$ :

$$\Lambda(k) \triangleq E\{[\hat{\underline{y}}(k|k-1) - \underline{y}(k)][\hat{\underline{y}}(k|k-1) - \underline{y}(k)]^T\}$$

$$\hat{\underline{y}}(k|k-1) = C\hat{\underline{x}}(k|k-1) \tag{A-24}$$

$$\hat{\underline{y}}(K|K-1) - \underline{y}(K) = C\{\hat{\underline{x}}(K|K-1) - \underline{x}(K) - \underline{v}(K)$$

From Eq. (A-24) we get

$$\Lambda(K) = CP(K|K-1) C^T + R(K) .$$

These equations are simulated and tested as discussed in Chapter IV.

APPENDIX B

THE MULTIVARIABLE NORMAL DISTRIBUTION

In this dissertation the multivariable normal distribution appears in many cases. As with the M.K.F., this appendix summarizes the equations of such a process.

Let's denote the random variables  $x_1, \dots, x_n$  by the column vector:

$$\tilde{x} = \begin{bmatrix} x_1 \\ \cdot \\ \cdot \\ \cdot \\ x_n \end{bmatrix} \quad (B-1)$$

The covariance matrix  $\Lambda$  is defined as:

$$\Lambda = \begin{bmatrix} \sigma_{11} & \sigma_{12} & \dots & \sigma_{1n} \\ \sigma_{21} & \dots & \dots & \dots \\ \cdot & & & \\ \cdot & & & \\ \cdot & & & \\ \sigma_{n1} & & & \sigma_{nn} \end{bmatrix} \quad (B-2)$$

where the elements  $\sigma_{ij}$  are given by:

$$\sigma_{ij} = E\{(X_i - U_k)(X_j - U_j)\} \quad (B-3)$$

The matrix is symmetric because

$$\sigma_{ij} = \sigma_{ji} \quad (\text{B-3})$$

And the vector  $\underline{u}$  (the vector mean of  $\underline{x}$ ) by:

$$\underline{u} \triangleq E \begin{bmatrix} x_1 \\ \cdot \\ \cdot \\ \cdot \\ x_n \end{bmatrix} = \begin{bmatrix} u_1 \\ \cdot \\ \cdot \\ \cdot \\ u_n \end{bmatrix} \quad (\text{B-5})$$

It can be shown that, for the n-variate case, the joint density  $f(\underline{x})$  is given by:

$$f(\underline{X}) = (2\pi)^{-n/2} |\Lambda|^{-1/2} \exp\left\{-\frac{1}{2}(\underline{X}-\underline{U})^T \Lambda^{-1} (\underline{X}-\underline{U})\right\} \quad (\text{B-6})$$

where

$$|\Lambda| \triangleq \det [\Lambda] \quad (\text{B-7})$$

Also, we can write in matrix notation that:

$$\Lambda = E\{(\underline{X}-\underline{U})(\underline{X}-\underline{U})^T\} \quad (\text{B-8})$$

And:

$$\underline{u} = E\{X\}$$

As a matter of interest, we note that the n-variable normal moment generating function can be written as

$$M(\underline{t}) = \exp\{\underline{U}^T \underline{t} + \underline{t}^T \underline{\Lambda} \underline{t} / 2\} \quad (\text{B-9})$$

where:

$$\underline{t} \triangleq \begin{bmatrix} t_1 \\ \vdots \\ t_n \end{bmatrix} \quad (\text{B-10})$$

$$M(\underline{t}) = E\{\exp(\underline{t}^T \underline{X})\} \quad (\text{B-11})$$

And by direct differentiation we can find that:

$$E\{X_1^a X_2^b \dots\} = \frac{\partial^{a+b+\dots} [M(\underline{t})]}{\partial t_1^a \partial t_2^b \dots} \Big|_{\underline{t}=0} \quad (\text{B-12})$$

The results are for the four moments, in four dimensional case:

$$\begin{aligned} E[X_1 X_2 X_3 X_4] &= E[X_1 X_2] E[X_3 X_4] + E[X_1 X_3] E[X_2 X_4] \\ &+ E[X_1 X_4] E[X_2 X_3] - 2E[X_1] E[X_2] E[X_3] E[X_4] \end{aligned} \quad (\text{B-13})$$

One of the interesting and useful properties of normal random variables is that they are invariant to linear transformations. In other words, a linear transformation of a normal random variable is a normal random variation too.

The result is that for the transformation

$$\underline{\tilde{Y}} = A \underline{\tilde{X}} \quad (\text{B-14})$$

where:

$$\underline{\tilde{Y}} = \begin{bmatrix} Y_1 \\ \cdot \\ \cdot \\ Y_n \end{bmatrix}$$

A = n x m matrix

is

$$\underline{U}_{\tilde{Y}} \triangleq E[\underline{\tilde{Y}}] = A \underline{U} \quad (\text{B-15})$$

$$\Lambda_{\tilde{Y}} \triangleq \text{COVAR}[\underline{\tilde{Y}}] = A \Lambda A^T \quad (\text{B-16})$$

Let's take a special case but very useful for bivariate normal distribution with:

$$E[X_1] = E[X_2] = 0$$

$$\text{VAR}[X_1] = \text{VAR}[X_2] = \sigma^2 \quad (\text{B-17})$$

$$E[X_1 X_2] = \sigma^2 \rho$$

then:

$$\Lambda = \sigma^2 \begin{bmatrix} 1 & \rho \\ \rho & 1 \end{bmatrix}$$

and we can write the p.d.f. by:

$$f_X(X_1, X_2) = \frac{1}{2\pi\sigma^2} \sqrt{1-\rho^2} \exp\left[-\frac{X_1^2 + X_2^2 + 2\rho X_1 X_2}{2\sigma^2(1-\rho^2)}\right] \quad (\text{B-18})$$

The p.d.f. of one variable given by

$$f_X(X) = \frac{1}{\sqrt{2\pi\sigma^2}} \exp\left[-\frac{X^2}{2\sigma^2}\right] \quad (\text{B-19})$$

The conditional p.d.f. is:

$$f_{X_2|X_1}(X_2|X_1) = f_X(X_1, X_2) / f(X_1) \quad (\text{B-20})$$

Thus

$$\begin{aligned}
 f_{X_2|X_1}(x_2|x_1) &= \frac{1}{\sqrt{2\pi\sigma^2(1-\rho^2)}} \exp \left[ -\frac{\rho^2 x_1^2 + x_2^2 + 2x_1 x_2}{2\sigma^2(1-\rho^2)} \right] \\
 &= \frac{1}{\sqrt{2\pi\sigma^2(1-\rho^2)}} \exp \left[ -\frac{(\rho x_1 + x_2)^2}{2\sigma^2(1-\rho^2)} \right] \quad (\text{B-21})
 \end{aligned}$$

## APPENDIX C

### TRANSFORMATION OF RANDOM VARIABLES

Consider the problem that arises when a random variable  $x$  is transformed to a new random variable  $y$  through a functional relationship  $y = h(x)$ . The usual problem is, find the distribution of  $y$ , given the distribution of  $x$ .

For a monotonic function, it can be shown that [22], [1]:

$$f_Y(Y) = f_X(X) \left| \frac{dx}{dy} \right| \quad (C-1)$$

Or by writing:

$$x = h^{-1}(y) \quad (C-2)$$

Then:

$$f_Y(Y) = f_X[h^{-1}(Y)] \left| \frac{d}{dy}[h^{-1}(Y)] \right| \quad (C-3)$$

This only applies when  $h^{-1}$  exists and it is continuously differentiable function of  $x$ . For this case, we must start from the basic idea which is:

$$P(Y \leq b) = P(\text{Set of } x \text{ corresponding to } Y \leq b) \quad (C-4)$$

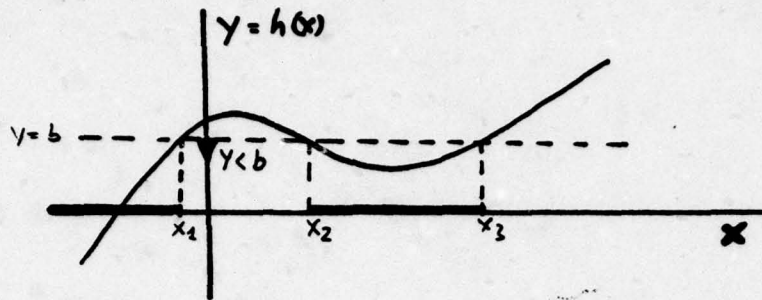

For example, the set of  $x$  corresponding to  $Y \leq b$  is the intervals

$$(-\infty, x_1), (x_2, x_3)$$

So by the definition of  $f_X(X)$  we can write:

$$P(Y \leq b) \triangleq F_Y(b) = \int_{\Gamma} f_X(x) dx \quad (C-5)$$

where

$$\Gamma = \{ \text{all the values of } x \text{ for which } Y \leq b \}.$$

A very useful example of transformation is the square law transformation:

$$y = x^2 \quad (C-6)$$

Then:

$$F_Y(b) = \int_{-\sqrt{b}}^{\sqrt{b}} f_X(x) dx ; \quad b \geq 0 \quad (C-7)$$

differentiating with respect to  $b$ , we have:

$$f_Y(b) = \frac{f_X(\sqrt{b}) + f_X(-\sqrt{b})}{2\sqrt{b}}$$

Replacing  $b$  by  $y$  we get:

$$f_Y(y) = \frac{f_X(\sqrt{y}) + f_X(-\sqrt{y})}{2\sqrt{y}} \quad (C-8)$$

Now let's take the normal Gaussian density; then we get:

$$f_Y(y) = \frac{1}{2\sqrt{2\pi y}} [\exp(-y/2) + \exp(-y/2)]$$

or

$$f_Y(y) = (2\pi y)^{-1/2} \exp[-y/2] \quad (C-9)$$

Now, let's take the case of two variables:

$$y_1 = h_1(x_1, x_2) \quad (C-10)$$

$$y_2 = h_2(x_1, x_2)$$

It can be shown that if  $y_1$  and  $y_2$  are related to  $x_1$  and  $x_2$  through continuously differentiable transforms then [1], [22]:

$$f_{\underline{Y}}(\underline{Y}) = f_{\underline{X}}(\underline{X}) |J(X|Y)| \quad (C-11)$$

where:

$$J(x|y) \triangleq \det \begin{bmatrix} \frac{\partial x_1}{\partial y_1} & \frac{\partial x_1}{\partial y_2} \\ \frac{\partial x_2}{\partial y_1} & \frac{\partial x_2}{\partial y_2} \end{bmatrix} \quad (C-12)$$

$J$  is called the Jacobian of the transformation. Where the transformations are not one to one, we must start from the definition:

$$F_Y(b_1, b_2) = \int_{\Gamma} \int f(x_1, x_2) dx_1 dx_2 \quad (C-13)$$

$$\Gamma = \{ \text{set of } x_1, x_2 \text{ such that } y_1 \leq b_1 \\ \text{and } y_2 \leq b_2 \}$$

Now, by differentiating  $F_Y$  with respect to  $b_1$  and  $b_2$  and setting  $b_1 = y_1$ ,  $b_2 = y_2$ , we get the proper p.d.f.

## APPENDIX D

### SEPARATION OF SIGNALS BY PROBABILITY FILTER

#### 1. Introduction

The general problem of separation of two signals is well discussed in the literature and the most familiar are Kalman and Weiner filters. We, in general, call one signal "noise" and the second signal is called simply "signal", and the problem is to estimate the signal when we have a noisy measurement. The most discussed and developed method of separation is for linear models, i.e., in control theory we have a general discrete model:

$$\begin{aligned}\underline{\tilde{x}}(i+1) &= \Phi \underline{\tilde{x}}(i) + \Delta \underline{U}(i) + \Gamma \underline{W}(i) \\ & \hspace{20em} (D-1) \\ \underline{Z}(i) &= C \underline{\tilde{x}}(i) + D \underline{V}(i)\end{aligned}$$

When  $\underline{\tilde{x}}$  is the state vector,  $\underline{Z}$  is the measured vector,  $\underline{W}$  and  $\underline{V}$  are noises,  $\underline{U}$  is known control input,  $\Phi, \Delta, \Gamma, C, D$  are matrices (may be a function of time).

A problem arises when the system is not linear. There are many possibilities to solve this problem, and the most widely used are the extended Kalman filter, maximum likelihood filter, and the Bayesian approach. Here we use a new method which will be called the "probability filter." The advantage of this filter is that the knowledge required for

AD-A066 367

NAVAL POSTGRADUATE SCHOOL MONTEREY CALIF  
STOCHASTIC SEPARATION OF RADAR SIGNALS.(U)  
DEC 78 Z W SHLOMO

F/G 17/9

UNCLASSIFIED

3 OF 3

AD  
A066367



NL

END  
DATE  
FILMED

5--79

DDC

this filter is less than for the likelihood or Kalman filters, i.e., the only required knowledge is at most the a priori p.d.f. of the measured signal (sometimes even the knowledge of the p.d.f. might be non accurate). We will show that this method is an extension of the method known as "method of moments." In the next paragraph we will describe briefly the method of moments and after that we will introduce the new approach.

## 2. Review of the Method of Moments

The method of moments is simple and intuitive. It is practical in the sense that it leads to a computationally reasonable estimator. This method can be established without the a priori knowledge of its p.d.f., but it requires a conditional p.d.f. on the observation. In practice, it requires even less than this - only knowledge of the several first moments of the process. It yields an estimation that is not necessarily optimal in any sense. On the other hand, the estimate approaches the true value as the amount of data processed becomes infinite. So, on the one hand, it is sometimes slow in obtaining results because the amount of data required for the estimation is high, but, on the other hand, in many cases the result is guaranteed to estimate the true value. We conclude that, in general, this method simply estimates the true value, but it is not an efficient estimator.

Now let us introduce the basic concept of this method (according to Ref. [1] and [51]). The two references do not refer to the ambiguity problem which we have discussed above. Suppose that we have unknown vector parameter

$$\tilde{\theta}^T \triangleq [\theta_1, \dots, \theta_n] \quad (D-2)$$

and we have sampled data from  $Z(t)$ ;

$$z_j \triangleq Z(t_j), \quad j = 1, 2, \dots, m \quad (D-3)$$

$$Z^T \triangleq [z_1, \dots, z_m]$$

which depends on the vector parameter. Let's assume that the knowledge of the conditional moments from 1 to  $J$  of  $Z(t)$  is given, and exist, i.e.,

$$\alpha_i \triangleq E\{Z_u^i | \tilde{\theta}\} = f_i(\tilde{\theta}), \quad i = 1, 2, \dots, J \quad (D-4)$$

Let's suppose now that we have  $J$  estimators of the  $J^{\text{th}}$  moments, so we can write:

$$\begin{aligned} \hat{\alpha}_1 &= f_1(\tilde{\theta}) \\ &\vdots \\ \hat{\alpha}_J &= f_J(\tilde{\theta}) \end{aligned} \quad (D-5)$$

Now we have  $J$  equations with  $n$  unknown parameters,  $\theta_1, \theta_2, \dots, \theta_n$ . In general  $J \geq n$  because the functions are not linear.

If we have the same number of equations as unknowns it can lead to a non-unique solution. So for uniqueness we can use more equations than the number of the unknowns.

Note: The problem of ambiguity can be also addressed by the Modified Kalman filter (see Appendix A).

Example: D-1. (Refer to Fig. D-1.)

If we are given only two equations,  $f_1(\theta)$  and  $f_2(\theta)$ , with two parameters,  $\theta_1$  and  $\theta_2$ , we have two possibilities for the vector  $\theta$ :  $\theta^{(1)}$  and  $\theta^{(2)}$ . To decide what is the acceptable solution, we must have at least one more equation. With the addition of a third equation we accept one of the solutions. Note that the third equation does not lead to the same solution as the first two equations, because of the error in estimating the moments. Because in many of the cases, the estimation is an increasing function of  $J$ , the last equation is used only for decisions and not for estimation, i.e., our solution is:

$$\begin{aligned} \text{if: } |f_3(\theta^{(1)}) - \hat{\alpha}_3| < |f_3(\theta^{(2)}) - \hat{\alpha}_3| & \text{ choose } \theta^{(1)} \\ \text{if: } |f_3(\theta^{(2)}) - \hat{\alpha}_3| < |f_3(\theta^{(1)}) - \hat{\alpha}_3| & \text{ choose } \theta^{(2)} \end{aligned} \tag{D-6}$$

The block diagram of the method of moments is given in Fig. D-2.

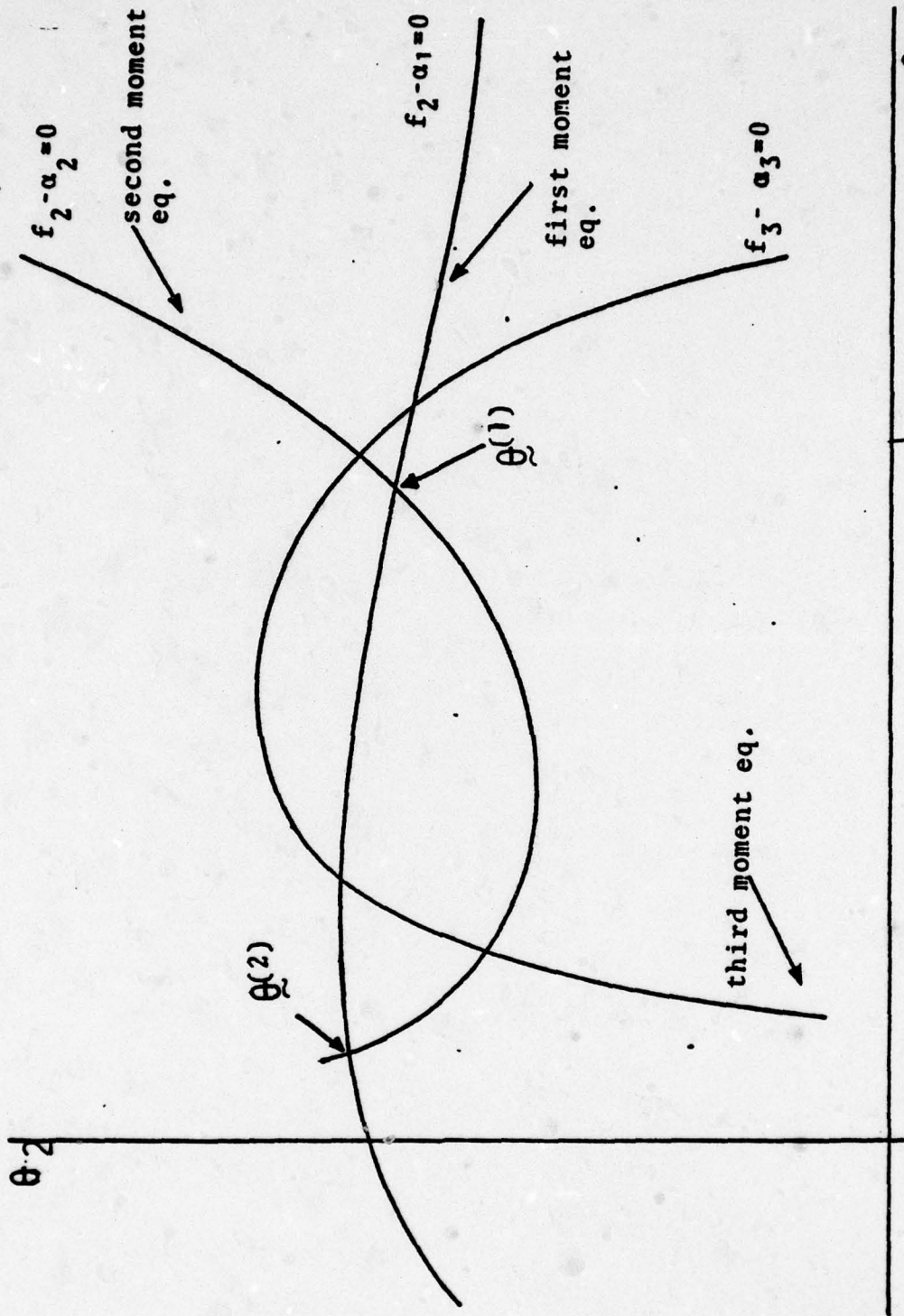
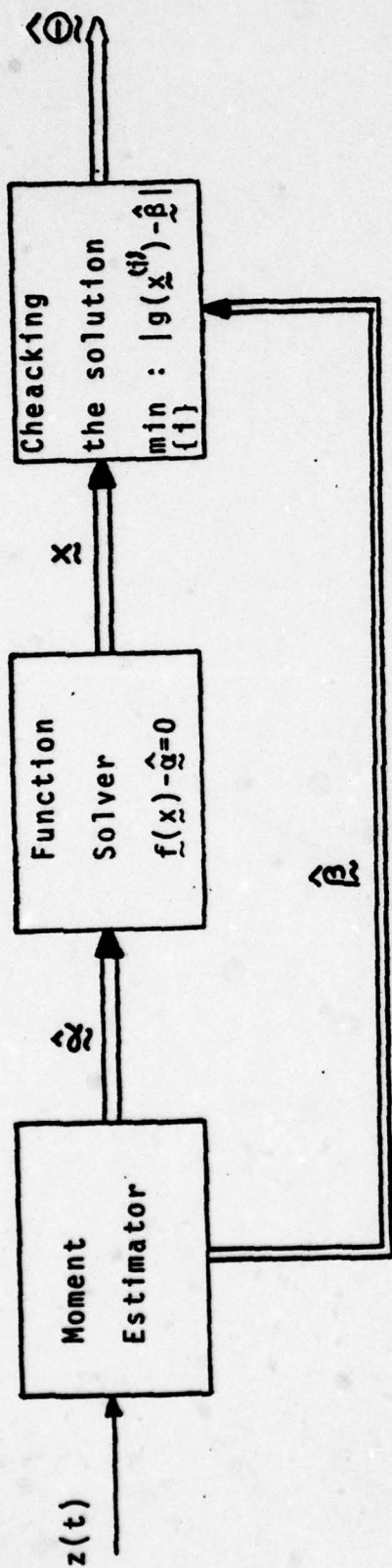

Fig. D-1. The concept of determining the solution for two unknowns with three non-linear equations.



$z(t)$  - the input signal

$\hat{x}$  - the first vector of estimated moments (the first  $n$  moments)

$\hat{\beta}$  - the last vector of estimated moments (the last  $J-n$  moments)

$\tilde{x}$  - the possible solution of the parameter

$\hat{\theta}$  - the selected parameters

Fig. D-2. Block diagram of the method of moments estimator.

In most of the cases the computational method of estimating the moments are simply by the definition of the moments, i.e.,

$$\hat{a}_j = \frac{1}{m} \sum_{i=1}^m (z_i)^j \quad (D-7)$$

It is not difficult to generate examples in which the method of moments does not even lead to an acceptable estimator (see Ref. [1]). In the following section we will see a new method which is a generalization of the method of moments.

### 3. The "Probability Filter"

In the method of moments we saw that when one wants to estimate the parameters the first  $J^{\text{th}}$  moments of the observed data is taken and we equate these to the  $J$  functions, the moments, and solve for the unknown parameters. Let's now suppose that  $J \rightarrow \infty$ . We choose the parameter in such a way that these infinite equations will lead to minimum error in some sense. For example:

$$\sum_{i=1}^{\infty} [\hat{\alpha}_i - f_i(\hat{\theta})]^2 \cdot w_i \rightarrow \min \quad (D-8)$$

when  $w_i \geq 0$ . In general,  $w_i$  is chosen as a decreasing function of  $i$ , for example  $w_i = 1/\text{var}\{\alpha_i - f_i(\hat{\theta})\}$ . The

method of moments is one example of D-8, i.e., by choosing:

$$\begin{aligned}w_i &= 1 & i &= 1, \dots, n \\w_i &= \epsilon_i > 0 & i &= n+1, \dots, J \\w_i &= 0 & i &> J\end{aligned}\tag{D-9}$$

We get exactly the method of moments discussed before. Now, let's understand what we mean by Equation D-8. If we take  $w_i > 0 \forall i$ , then we are trying in some sense to minimize the difference between the conditional p.d.f. and the measured p.d.f. That is, we can modify Equation D-8 by:

$$\|f_Z(Z|\hat{\theta}) - \hat{f}_Z(Z)\| \rightarrow \min\tag{D-10}$$

where

$$\hat{f}_Z(Z) = f_Z(Z(\hat{\theta}))$$

when  $\hat{f}_Z(Z)$  denotes the estimation of the p.d.f. of the data. (We will see later that for the probability filter we do not even have to estimate the p.d.f.) In the last equation we try to choose  $\hat{\theta}$  in such a way that the norm of the difference between the two p.d.f.'s is minimized.

Example D-2. (Refer to Fig. D-3.)

Let's assume that we have only one parameter to estimate; from the figure we choose  $\theta_1$  and not  $\theta_2$  because  $\theta_1$  gives a theoretical p.d.f. which is closer to the measured p.d.f. than  $\theta_2$ .

Let us now choose the norm:

$$I = \frac{1}{2} \int_{-\infty}^{\infty} [f_Z(z|\hat{\theta}) - \hat{f}_Z(z)]^2 dz \rightarrow \min \quad (D-11)$$

That is, we choose  $\hat{\theta}$  in such a way that it minimizes the difference between the two p.d.f.'s in a mean square sense.

Now, let us take the derivative of I with respect to  $\theta$ , and set it equal to zero to find the minimum, i.e., a necessary condition for minimization is:

$$\begin{aligned} 0 &= \frac{\partial I}{\partial \hat{\theta}_i} = \int_{-\infty}^{\infty} [f_Z(z|\hat{\theta}) - \hat{f}_Z(z)] \cdot \frac{\partial f_Z(z|\hat{\theta})}{\partial \hat{\theta}_i} dz \\ \frac{\partial I}{\partial \hat{\theta}_i} &= \int_{-\infty}^{\infty} \frac{\partial f_Z(z|\hat{\theta})}{\partial \hat{\theta}_i} f_Z(z|\hat{\theta}) dz - \int_{-\infty}^{\infty} \frac{\partial f_Z(z|\hat{\theta})}{\partial \hat{\theta}_i} \hat{f}_Z(z) dz \\ &= g_i(\hat{\theta}) - \frac{\overline{\partial f_Z(z|\hat{\theta})}}{\partial \hat{\theta}_i} = g_i(\hat{\theta}) - \widetilde{\frac{\partial f_Z(z|\hat{\theta})}{\partial \hat{\theta}_i}} \quad (D-12a) \end{aligned}$$

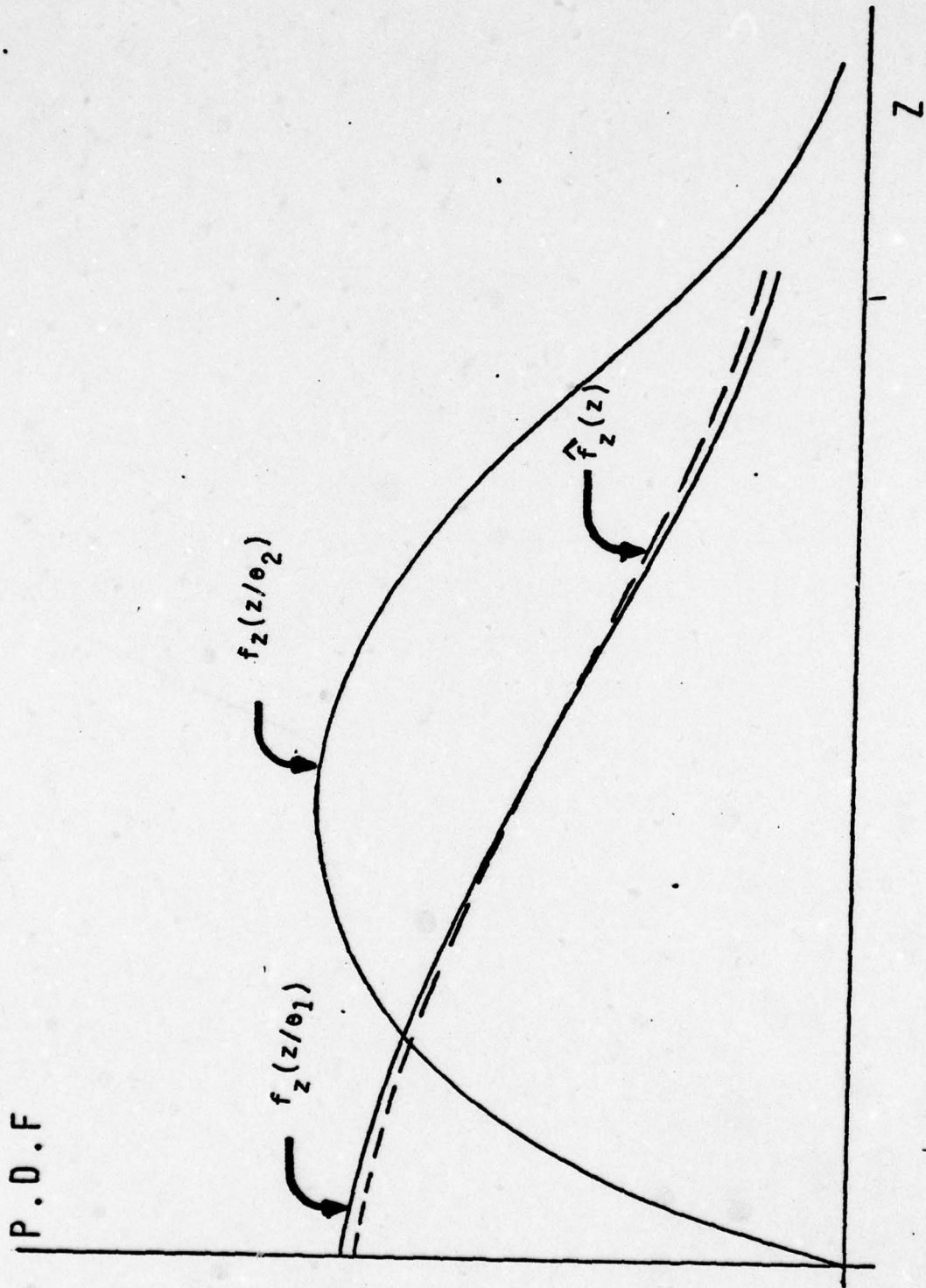

Figure D-3.

where the symbol " $\sim$ " means time average. The time average can be approximated by:

$$\frac{\overline{\partial f_Z(Z|\hat{\theta})}}{\partial \hat{\theta}_i} \cong \frac{1}{T} \int_0^T \frac{\partial f_Z(Z(t)|\hat{\theta})}{\partial \hat{\theta}_i} dt \quad (D-12b)$$

In our problem we try to estimate the amplitudes received at each receiver (which is proportional to the RCS of the target, see Chapter IV.A). Since we restrict ourselves to surface targets (which means low dynamic), the RCS of each target (ship and chaff) can be assumed to be stationary compared to the missile's flight time. Hence we can use "T", the time interval at the last equation (D-12b), small enough compared to the missile's flight time.

Eq. (D-12,D-12a) follow because:

$$g_i(\hat{\theta}) = \int_{-\infty}^{\infty} \frac{\partial f_Z(Z|\hat{\theta})}{\partial \hat{\theta}_i} f_Z(Z|\hat{\theta}) dz$$

is a known function of  $\hat{\theta}$  and can be computed a priori.

Also

$$\int_{-\infty}^{\infty} \frac{\partial f_Z(Z|\hat{\theta})}{\partial \hat{\theta}_i} \hat{f}_Z(Z) dz$$

is the mean value of the function  $\frac{\partial f_Z(Z|\hat{\theta})}{\partial \hat{\theta}_i}$  with respect to

Z. Because we are assuming ergodic processes, the ensemble mean and the time mean are the same. So we can write:

$$g_i(\hat{\theta}) - \frac{\overline{\partial f_Z[Z(t) | \hat{\theta}]}{\partial \hat{\theta}_i} = 0 \quad (D-13)$$

Because we have n parameters, we have n equations. Note that also in this case as in the method of moments, the equations are not linear and we may get a non-unique solution. Thus we may have to add more equations to the set of equations D-13; for example, the equations of moments as discussed previously. Alternately we propose to use the M.K.F. (Appendix A) with all the possible solutions.

A block diagram of the probability filter is given in Fig. D-4. The input signal Z(t) is substituted into

$$\frac{\partial f_Z(Z(t) | \hat{\theta})}{\partial \hat{\theta}_i}$$

and the function is averaged by the block following. Also,  $g_i(\hat{\theta})$  is produced. If the difference between the two is not zero, the value of  $\hat{\theta}$  is changed until the difference between the two approaches zero. The initial condition for the integrator can be determined by the method of moments or as in the Kalman filter, the statistical mean of the parameters.

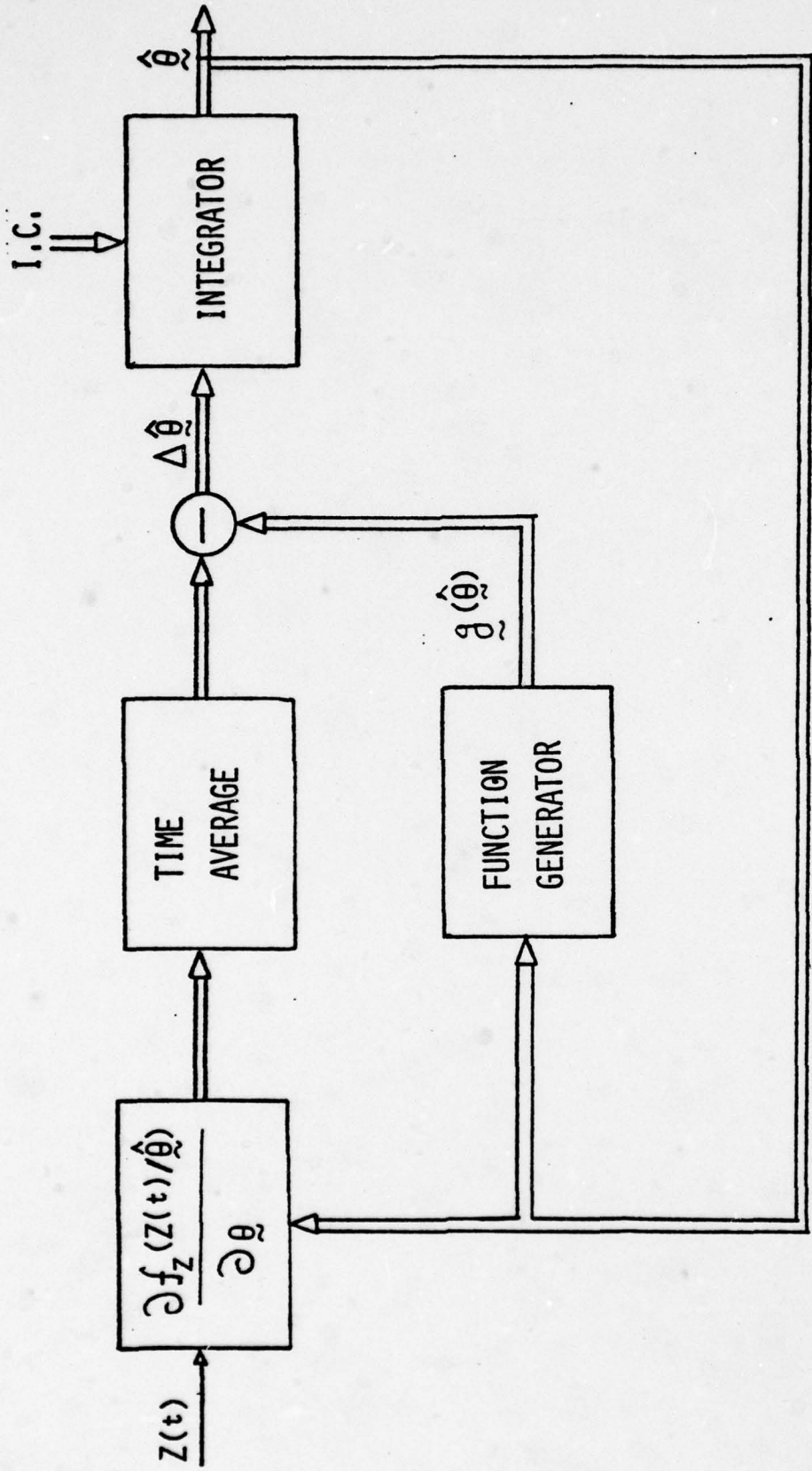

Fig. D-4. Block diagram of the probability filter.

Example D-3.

In this example we introduce a simple case of estimating a parameter by the probability filter. We choose the exponential distribution. The p.d.f. is given by:

$$f_Z(z|\theta) = \theta e^{-\theta z} \quad z \geq 0 \quad (D-14)$$

We can get the equation for the probability filter:

$$\frac{\partial f_Z(z|\theta)}{\partial \theta} = e^{-\theta z} - \theta z e^{-\theta z} \quad (D-15)$$

$$g_1(\theta) = \int_0^{\infty} \frac{\partial f_Z(z|\theta)}{\partial \theta} f_Z(z|\theta) dz = + \frac{1}{4} \quad (D-16)$$

Thus  $g_1(\theta)$  has a very simple expression, i.e.,

$$g_1(\theta) = + 0.25 \quad (D-17)$$

Thus the equation for the probability filter is, from Eq. (D-13),

$$+0.25 + \frac{1}{N} \sum_{i=1}^N e^{-\hat{\theta} z_i} (\hat{\theta} z_i - 1) = 0 \quad (D-18)$$

The last equation is the probability filter equation. It is a non-linear equation and we must solve it numerically for  $\hat{\theta}$ .

Until now we have seen the direct implementation of the filter, i.e., determine the probability filter equation and solve for the parameters. Direct implementation of the filter is only one possible way of implementation. There are other possible implementations which give the filter its uniqueness. We introduce two possibilities of using the filter. In many cases we do not have the exact p.d.f. of the process but we have an approximation of it and a reference signal which represents the signal (e.g., by recording the signal previously). We give here two ways of using the probability filter when the exact p.d.f. is not known.

(i) The solution when only the approximate p.d.f. is given and a reference signal is available. This filter gives us the opportunity to estimate parameters even if our information about the data is not precisely given; that is, if we have a record of this kind of data, we can compare the two systems very easily.

Let's return to Eq. D-12b. We have:

$$\frac{\partial I}{\partial \hat{\theta}_i} = \int_{-\infty}^{\infty} \frac{\partial f_Z(z|\hat{\theta})}{\partial \hat{\theta}_i} f_Z(z|\hat{\theta}) dz - \int_{-\infty}^{\infty} \frac{\partial f_Z(z|\hat{\theta})}{\partial \hat{\theta}_i} \hat{f}_Z(z) dz$$

set  
= 0

(D-19)

Let us assume that  $f_Z(Z|\hat{\theta})$  is only an approximation of the p.d.f., so we cannot "trust" this given p.d.f. completely. Like in the Kalman filter, we assume an approximate model of the system, and by closing the loop we guarantee that the estimator behaves quite well even if our model does not precisely describe the real model.

Equation D-19 gives us the possibility to close the loop as in a Kalman filter. Eq. D-19 has two terms. The first one is computed "off" line if the p.d.f.  $f_Z(Z|\hat{\theta})$  is completely known. If the p.d.f. is unknown exactly, then the technique of comparing two terms is the best that we can do. We see that the two terms are almost the same.

Assume we have a reference signal X with the p.d.f.:

$$f_X(X|\hat{\theta}) = f_Z(X|\hat{\theta}) \quad (D-19a)$$

Thus:

$$\int_{-\infty}^{\infty} \frac{\partial f_Z(Z|\hat{\theta})}{\partial \hat{\theta}_i} f_Z(Z|\hat{\theta}) dZ = \frac{\partial f_Z(X|\hat{\theta})}{\partial \hat{\theta}_i}$$

Thus we can write:

$$\frac{\partial I}{\partial \hat{\theta}_i} = \frac{\partial f_Z(X|\hat{\theta})}{\partial \hat{\theta}_i} - \frac{\partial f_Z(Z|\hat{\theta})}{\partial \hat{\theta}_i} \text{ set } = 0 \quad (D-19b)$$

$$x = x(t, \hat{\theta})$$

$$z = z(t, \hat{\theta})$$

The first term comes from the reference system, so by computing the two terms we can assume that when the difference between the two terms becomes zero,  $\hat{\theta}$  is close to the true  $\theta$ .

Figure D-5 demonstrates the idea. We measure the data,  $z(t, \hat{\theta})$ , transform the data to get the function  $h_i(z, \hat{\theta})$ , where

$$h_i(\omega, \hat{\theta}) = \frac{\partial}{\partial \hat{\theta}_i} g(\omega | \hat{\theta}) \quad (D-20)$$

and  $g(\omega | \hat{\theta})$  is an approximation of  $f(\omega | \theta)$  that has been chosen for its analytic form.

In the original form of the probability filter equation (D-12a), we get an error when  $f_z(Y | \theta)$  is not known exactly. Thus by implementing the probability filter equation (D-12a) we get a biased estimator. On the other hand if we have a reference signal, in case that  $f_z$  is not known exactly, we get:

$$\overbrace{h_i(x(r, \hat{\theta}), \hat{\theta})} - \overbrace{h_i(z(t, \hat{\theta}), \hat{\theta})} = e_i \quad (D-21a)$$

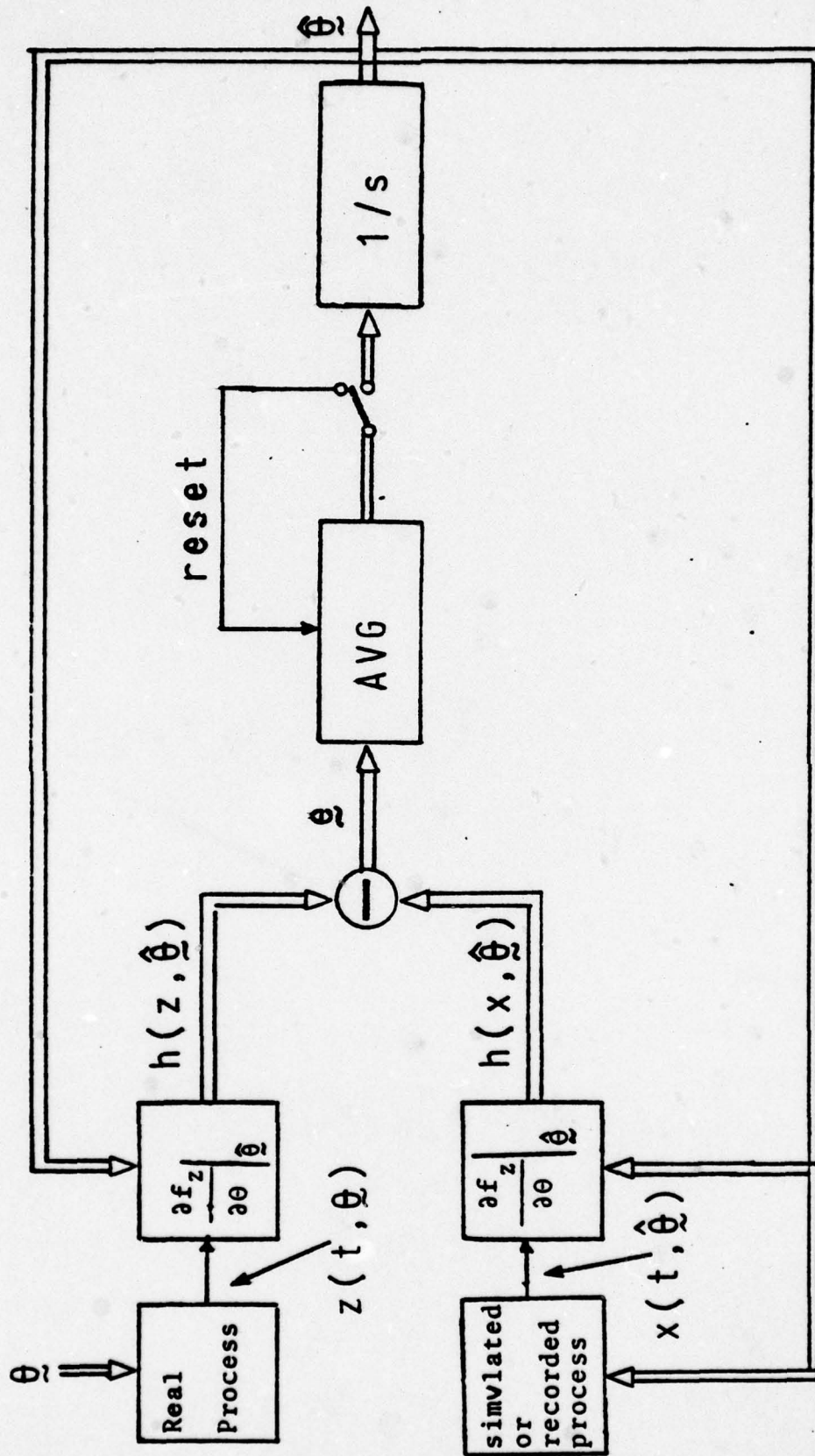

Figure D-5. Probability filter when a reference is given.

For this case when  $\hat{\theta} = \theta$ :

$$\begin{aligned}
 e_i &= E[h_i(X(t, \theta), \theta) - h_i(Z(t, \theta), \theta)] && (D-21b) \\
 &= \int_{-\infty}^{\infty} h_i(\zeta, \theta) f_Z(\zeta | \theta) d\zeta - \int_{-\infty}^{\infty} h_i(\zeta, \theta) f_Z(\zeta | \theta) d\zeta \\
 &= 0
 \end{aligned}$$

This result follows because of the assumption that we have a reference signal with the same p.d.f. as the signal, (D-19a).

Thus where the reference signal has the same functional equation as the measured signal, we get an unbiased estimator, independent of  $h_i(\zeta, \theta)$ , which is a function of the assumed p.d.f. However the feedback process can only be expected to converge when  $g(\omega | \theta)$  is a reasonable approximation to  $f_Z(\omega | \theta)$ .

In the regular "probability filter" we get a bias estimator when the p.d.f. is not known exactly.

(ii) Indication of Change in a System

Sometimes we like to check if parameters in a system have been changed. By taking a reference signal (from similar systems with nominal parameters or by recording the output from the system from the past), we can easily check if some parameters have been changed.

Indication of change in the system is that:

$$|e_i| > \epsilon_i \quad (D-23)$$

where  $\epsilon_i$  is a constant dependent upon the acceptable false alarm. The block diagram is given in Fig. D-6.

By adding more calculations we might determine the value of the parameters that were changed, by simply applying the probability filter.

The probability filter implementation for the unresolved targets and the simulation of the probability filter are given in Chapter V.

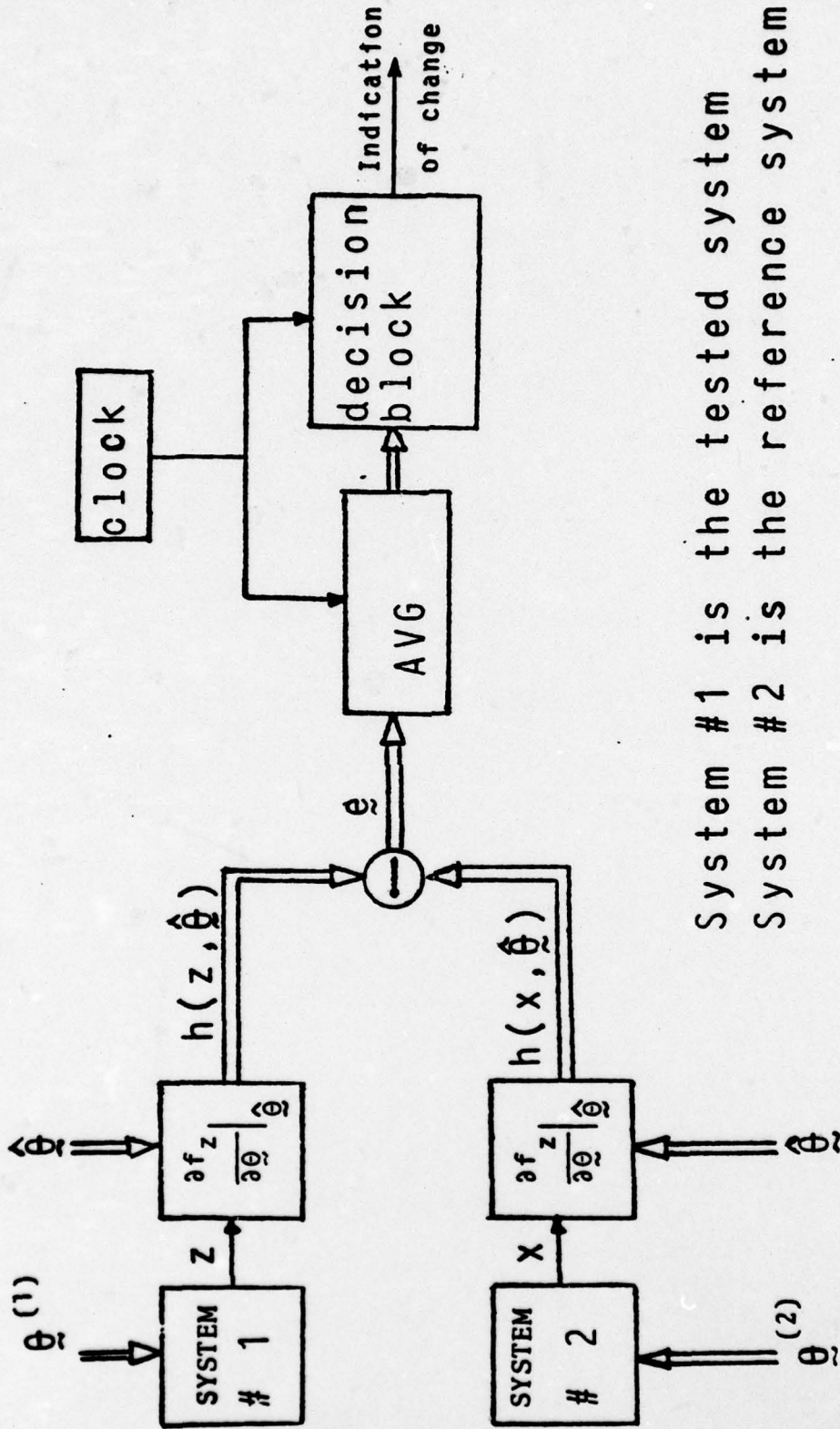

System #1 is the tested system  
 System #2 is the reference system

Figure D-6. Indication of change in a system by the probability filter.

## APPENDIX E

### THE MAXIMUM LIKELIHOOD ESTIMATOR

A reasonable estimate of a parameter is one which makes a given observation most likely, i.e., choose for the parameters  $\underline{\theta}$ , that value which maximizes the conditional p.d.f.  $f(\underline{z}|\underline{\theta})$ . The p.d.f.  $f(\underline{z}|\underline{\theta})$  is called the likelihood function. Because of the exponential character of many density functions, it is convenient to deal with the natural logarithm of the likelihood function -  $\ln\{f(\underline{z}|\underline{\theta})\}$ . Clearly, because  $f(\underline{z}|\underline{\theta}) \geq 0$ ,  $\ln f(\underline{z}|\underline{\theta})$  exists, so by choosing  $\underline{\theta}$  to maximize  $\ln\{f(\underline{z}|\underline{\theta})\}$  it maximized also  $f(\underline{z}|\underline{\theta})$ . A necessary condition that  $\underline{\theta}$  maximize the likelihood function is:

$$\frac{\partial}{\partial \theta_i} \ln f(\underline{z}|\underline{\theta}) = 0 \quad i = 1, 2, \dots, m \quad (E-1)$$

By setting all the  $m$  equations with  $m$  unknowns, one can solve for the unknown vector  $\underline{\theta}$ . It can be shown that in many cases the maximum likelihood function is a biased estimator, but the bias tends to zero [30]. Also the variance of the error tends to zero as numbers of samples increase. We can say that the likelihood estimator is asymptotically efficient.

## APPENDIX F

### ESTIMATORS FOR SYSTEM DESCRIBED BY DIFFERENTIAL/DIFFERENCE EQUATION

#### 1. INTRODUCTION

In this dissertation we deal with estimators. The purpose of this appendix is to summarize the approaches given in the literature and establish the symbols and terminology used. There are two major approaches: the discrete and the continuous time. For our case, we deal with discrete time process.

The difference equations for the discrete time and the measurement is given by:

$$\underline{X}(K+1) = \psi(\underline{X}(K), K+1, K) + \Gamma(\underline{X}(K), K)\underline{W}(K) \quad (F-1)$$

$$\underline{Y}(K) = h(\underline{X}(K), K) + \underline{V}(K)$$

where

$\psi, \Gamma, h$  - are known matrices

$\underline{W}(K), \underline{V}(K)$  - are independent sequences of independent random variables (not Gaussian in general)

The only known case when the equations can be effectively solved (computed) exactly is the linear process plus

Gaussian noise. This solution was obtained by Kalman [2] and Kalman and Bucy [3]. The known existence of this exact solution led to the approximate solution for the case where the plant and the measurements equation are almost linear and the noise processes are nearly Gaussian [10]. But the Gaussian approximation and/or linearization are not adequate for many problems due to strong nonlinearity, as well as for non-Gaussian noise process. This has led to the development of many other kinds of approximations, for example, Gaussian sum approximations [5], [6]. A good reference for many approximations can be found in the proceedings of the 6th nonlinear estimation theory symposium [7].

From equation (F-1) we see that the frequent problem is:

The measurement noise and the plant noise are additive, with at most a state dependent multiplier, when the noise is in the form of Brownian motion.

## 2. LINEAR SYSTEM - KALMAN ESTIMATOR

Let's assume that our system described by a linear difference equation which is given by [31]:

$$\underline{X}(K+1) = \Phi \underline{X}(K) + \Delta \underline{U}(K) + \underline{W}(K) \tag{F-2}$$

$$\underline{Y}(K) = C \underline{X}(K) + \underline{V}(K)$$

where

- $\underline{X}(K)$  - are the states of the system at time  $K$
- $\underline{U}(K)$  - the control input to the system at time  $K$  (it is a known, deterministic)
- $\underline{W}(K)$  - the random forcing input
- $\underline{V}(K)$  - the measurement noise
- $\underline{Y}(K)$  - the measured vector

The statistical properties of the variables are given by:

- (1) The measurement noise:

$$E[\underline{V}(K)] = \underline{0} \quad K \geq 0 \quad (F-3)$$

$$E[\underline{V}(K)\underline{V}^T(j)] = R\delta_{KJ} \quad k, j \geq 0$$

- (2) The initial state:

$$E[\underline{X}(0)] = \underline{\bar{X}}_0 \quad (F-4)$$

$$\text{COVAR} [\underline{X}(0)] = M$$

- (3) The forcing random process:

$$E[\underline{W}(K)] = \underline{0} \quad (F-5)$$

$$E[\underline{W}(K)\underline{W}^T(j)] = Q\delta_{Kj} \quad k, j \geq 0$$

(4) The correlation between the variables:

- (a) The measurement noise and the initial states are uncorrelated:

$$E[\underline{X}(0)\underline{V}^T(K)] = \underline{0} \quad K \geq 0 \quad (F-6)$$

- (b) The random forcing input and the initial state are uncorrelated:

$$E[\underline{X}(0)\underline{W}^T(K)] = \underline{0} \quad K \geq 0 \quad (F-7)$$

- (c) The forcing random process and the measurement noise are uncorrelated:

$$E[\underline{W}(K)\underline{V}^T(j)] = \underline{0} \quad K, j \geq 0 \quad (F-8)$$

The requirements for the filter are:

- (a) The estimator is characterized by linear relationship.
- (b) Unbiased estimator.
- (c) The estimator minimizes the trace of the error covariance matrix, i.e.:

$$\text{Trace } \{P(K, K)\} \rightarrow \min \quad (F-9)$$

where

$$P(K|K) \triangleq \text{COVAR}\{\hat{\underline{X}}(K|K) - \underline{X}(K)\}$$

$\hat{\underline{X}}(K|K)$  is the estimated state depending on the input data up to and including sample K.

The results of the Kalman estimator are given by [31]:

$$\hat{\underline{X}}(K|K) = \hat{\underline{X}}(K|K-1) + G(K) [Y(K) - C\hat{\underline{X}}(K|K-1)]$$

$$\hat{\underline{X}}(K|K-1) = \Phi X(K-1|K-1) + \Delta U(K-1) \quad (\text{F-10})$$

$$\hat{\underline{X}}(0|-1) = \bar{\underline{X}}(0)$$

where:

$$G(K) = P(K|K-1)C^T [CP(K|K-1)C^T + R]^{-1}$$

$$P(K|K) = [I - G(K)C] P(K|K-1)$$

$$P(K+1|K) = \Phi P(K|K)A^T + Q$$

$$P(0|-1) = M$$

Notes:

- (i) The Kalman filter is the optimum linear estimator for the given knowledge of the second order statistics only.

- (ii) There are other estimators, like nonlinear, which are superior to the Kalman filter for the general case.
- (iii) If all the variables are Gaussian, the optimal minimum variance estimator turns out to be the Kalman filter.

### 3. THE BAYESIAN APPROACH

The Bayesian approach simply takes the expected value of the state, given all the measured data, i.e.:

$$\hat{\underline{X}}(K|K) = E\{\underline{X}(K) | \underline{Y}(0), \dots, \underline{Y}(K)\} \quad (\text{F-11})$$

If we define:

$$\underline{Y}^{(K)} \triangleq [\underline{Y}(0), \dots, \underline{Y}(K)]$$

Then (F-11) can be formed as:

$$\hat{\underline{X}}(K|K) = E[\underline{X}(K) | \underline{Y}^{(K)}]$$

If we have the p.d.f. of the state given  $\underline{Y}^{(K)}$ , we can find the expected value of  $\underline{X}$ , i.e.:

$$\hat{\underline{X}}(K|K) = \int_{[\underline{X}]} \underline{X}(K) f[\underline{X}(K) | \underline{Y}^{(K)}] d\underline{X}(K) \quad (\text{F-12})$$

So the problem is to find the p.d.f.

$$f[\underline{x}(k) | \underline{y}^{(k)}] = \frac{f[\underline{x}(k) | \underline{y}^{(k-1)}] f[\underline{y}(k) | \underline{x}(k)]}{f[\underline{y}(k) | \underline{y}^{(k-1)}]}$$

$$f[\underline{x}(k) | \underline{y}^{(k-1)}] = \int_{[X]} f[\underline{x}(k-1) | \underline{y}^{(k-1)}] f[\underline{x}(k) | \underline{x}(k-1)] d\underline{x}(k-1)$$

$$f[\underline{y}(k) | \underline{y}^{(k-1)}] = \int_{[X]} f[\underline{x}(k) | \underline{y}^{(k-1)}] f[\underline{y}(k) | \underline{x}(k)] d\underline{x}(k)$$

$$f[\underline{x}(0) | \underline{y}^{(-1)}] \triangleq f[\underline{x}(0)]$$

Those equations, theoretically, give the complete solution of the estimation. The problem is that the integration can not be carried out in closed form. Thus, in most of the practical cases this solution is not used.

### LIST OF REFERENCES

1. N. G. Kendell, A. Stuart, The Advanced Theory of Statistics, Hafner Publishing Company, 1967.
2. Kalman, "A New Approach to Linear Filtering and Prediction Problem." Journal of Basic Engineering, Vol. 82, 1960, pp. 35-45.
3. Kalman and Bucy, "New Results in Linear Filtering and Prediction Theory." Journal of Basic Engineering, Vol. 83, 1961, pp. 95-108.
4. Jazwinski, A. H., Stochastic Processes and Filtering Theory. Academic Press, 1970.
5. Alspach, D. L. and Sorenson, H.W., "Nonlinear Bayesian Estimation using Gaussian Sum Approximation." IEEE Transactions on Automatic Control, Vol. AC-17, 1972, pp. 439-448.
6. Alspach, D. L., "A Bayesian Approximation Technique for Estimation and Control of Time Discrete Stochastic Systems." PhD Thesis, University of California, 1970.
7. Proceedings of the 6th Symposium on Nonlinear Estimation Theory and Its Applications, 1975, San Diego, CA.
8. Marcum, J. I., "A Statistical Theory of Targets Detection by Pulsed Radar." IRE Trans. Vol. IT-6, pp. 145-267, April 1960.
9. Natanson, F. E., Radar Design Principles. McGraw-Hill, 1969.
10. Sage, A. P. and Melsa, J. L., Estimation Theory with Application to Communication and Control. McGraw-Hill, 1971.
11. Wylie, C. R., Advanced Engineering Mathematics. McGraw-Hill, 1959.
12. Sherman, S. M., "Complex Indicated Angles Applied to Unresolved Targets and Multipath." IEEE Trans. Aerospace and Electronic Systems, Vol. AES-7, pp. 160-170, J-ne 1971.
13. Peebles, P. Z., "Multiple-Target Monopulse Radar Processing Techniques." IEEE Transaction on Aerospace and Electronic Systems, Vol. AES-4, #6, November 1968.

14. Freedman, J., "Resolution in Radar Systems." Proc. IRE 39, No. 7, July 1951, pp. 813-818.
15. Urkowitz, H., Haver, C. A., and Koval, J. F., "Generalized Resolution in Radar System." Proc. IRE 50, No. 10, Oct 1962, pp. 2093-2105.
16. Peebles, P. Z., and Goldman, L., "Radar Performance with Multipath Using the Complex Angle." IEEE Trans. AES-7, No. 1, January 1971, pp. 171-178.
17. Golden, A., "Radar Separation of Closely Spaced Targets." IEEE Spectrum, February 1966, pp. 94-99.
18. Berbowitz, R. S. and Sherman, S. M., "Information Derivable from Monopulse Radar Measurements of Two Unresolved Targets." IEEE Trans. AES-7, No. 5, September 1971, pp. 1011-1013.
19. Kosienki, A. A. and McGhee, R. B., "A Decision Theoretic Approach to the Angular Resolution and Parameter Estimation Problem for Multiple Targets." IEEE Trans. AES-4, No. 3, May 1968, pp. 443-455.
20. Pollon, G. E. and Lane, G. W., "Angular Tracking of Closely Spaced Radar Targets." IEEE Trans. AES-4, No. 4, July 1968, pp. 541-550.
21. Thomas, J. B., An Introduction to Statistical Communication Theory. John Wiley & Sons, 1969.
22. Papoulis, Probability, Random Variables, and Stochastic Processes. McGraw-Hill, 1965.
23. Skolnik, M. I., Introduction to Radar System. McGraw-Hill, 1962.
24. Aoki, H., Optimization of Stochastic Systems. Academic Press, 1967.
25. Jazawinski, Stochastic Processes and Filtering Theory. Academic Press, 1970.
26. Alspach, D. L. and LaGrotta, J., "A Parallel Processing Gaussian Sum Approach to the Dayton Problem." 4th Symposium on Nonlinear Estimation Theory and its Application, September 1973.
27. Bar-Shlom, Y. and Edison, B. E., "Tracking in a Cluttered Environment with Probabilistic Data Association." Proceedings of the 4th Symposium on Nonlinear Estimation, September 1973.

28. Nahi, N. E., "Optimal Recursive Estimation with Uncertain Observation." IEEE Transactions on Information Theory, Vol. 17-15, No. 4, July 1969.
29. Bar-Shlom, Y. and Jaffer, A. G., "Adaptive Nonlinear Filtering for Tracking with Measurements of Uncertain Origin." Proceedings of the 1972 IEEE Conference on Decision 4, 11th Symposium on Adaptive Processes, December 1972.
30. Nahi, N. E., Estimation Theory and Applications. John Wiley & Sons, 1969.
31. Kirk, E. D., "Optimal Estimation: An Introduction to the Theory and Applications." Naval Postgraduate School 1975 (unpublished).
32. Mehra, "On the Identification of Variance and Adaptive Kalman Filtering." IEEE Trans. on Automatic Control, Vol. AC-15, pp. 175-189, April 1970.
33. Mehra, "Approaches to Adaptive Filtering." IEEE Trans. on Automatic Control, Vol. AC-17, pp. 693-698, October 1972.
34. Mohanty, N. C., "Modeling Radar Reflections from Randomly Moving Scatterers." Proceedings of the IEEE, Vol. 66, No. 1, Jan. 1978.
35. Anderson, G. L. and Figueiredo, P. J. P., "An Adaptive Orthogonal-series Estimator for P.D.F. Functions," Technical Report #EE 7803, by Rice University, Feb. 1978.

INITIAL DISTRIBUTION LIST

	No. Copies
1. Defense Documentation Center Cameron Station Alexandria, Virginia 22314	2
2. Library, Code 0142 Naval Postgraduate School Monterey, California 93940	2
3. Electrical Engineering Department Chairman, Code 62 Department of Electrical Engineering Naval Postgraduate School Monterey, California 93940	2
4. Professor Sydney R. Parker, Code 62Px Department of Electrical Engineering Naval Postgraduate School Monterey, California 93940	10
5. Professor D.E. Kirk, Code 52Ki Department of Electrical Engineering Naval Postgraduate School, Monterey, California 93940	3
6. Professor G.J. Thaler, Code 62Tr Department of Electrical Engineering Naval Postgraduate School Monterey, California 93940	1
7. Professor G.A. Myers, Code 62Mv Department of Electrical Engineering Naval Postgraduate School Monterey, California 93940	1
8. Professor I.B. Russak, Code 53Ru Department of Mathematics Naval Postgraduate School Monterey, California 93940	1
9. Professor A.R. Washburn, Code 55Ws Department of Operations Research Naval Postgraduate School Monterey, California 93940	1

- |     |  |   |
|-----|--|---|
| 10. | Professor F.D. Faulkner, Code 53Fa<br>Department of Mathematics<br>Naval Postgraduate School<br>Monterey, California 93940                   | 1 |
| 11. | Professor H.A. Titus, Code 52Ts<br>Department of Electrical Engineering<br>Naval Postgraduate School<br>Monterey, California 93940           | 1 |
| 12. | Professor R.A. McGonigel, CDR, Code 54Mg<br>Department of Administrative Sciences<br>Naval Postgraduate School<br>Monterey, California 93940 | 1 |
| 13. | Lt. Zach Shlomo<br>5 S. Halon, Hod-Hashron<br>ISRAEL   | 3 |
| 14. | Mr. Weiss Jona<br>1 Hahachsroot, Hod-Hohron<br>ISRAEL  | 1 |
| 15. | Mr. Narkis Moshe<br>Israeli Navy,<br>c/o Embassy of Israel   | 1 |
| 16. | Lt. Zach Shlomo<br>Israeli Navy<br>c/o Embassy of Israel   | 3 |
| 17. | Lt. Shachar Moshe<br>Israeli Navy<br>c/o Embassy of Israel   | 1 |
| 18. | Commander M. Bachar<br>Israeli Navy<br>c/o Embassy of Israel   | 1 |
| 19. | LTCD V. Ben-Yakov<br>Department of Electrical Engineering<br>Naval Postgraduate School<br>Monterey, California 93940                         | 1 |
| 20. | LTCD S. Selef<br>Department of Electrical Engineering<br>Naval Postgraduate School<br>Monterey, California 93940                             | 1 |