

AD-A066 467

FOREIGN TECHNOLOGY DIV WRIGHT-PATTERSON AFB OHIO
CONTROLLED GAS-DISCHARGE DEVICE WITH A COLD CATHODE, (U)
SEP 78 I I AKSENOV, V A BELOUS, S A SMIRNOV
FTD-ID(RS)T-1422-78

F/G 9/1

UNCLASSIFIED

NL

| OF |
AD
A066467



END
DATE
FILMED
5-79
DDC

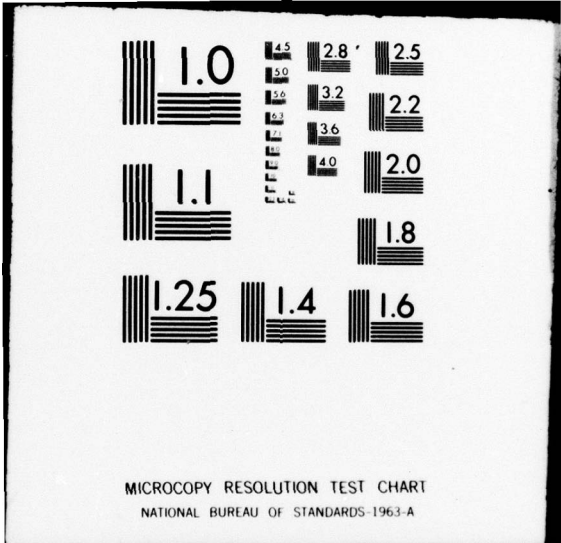

MICROCOPY RESOLUTION TEST CHART
NATIONAL BUREAU OF STANDARDS-1963-A



AD-A066467

FOREIGN TECHNOLOGY DIVISION



CONTROLLED GAS-DISCHARGE DEVICE WITH A COLD CATHODE

by

I. I. Aksenov, V. A. Belous, and S. A. Smirnov

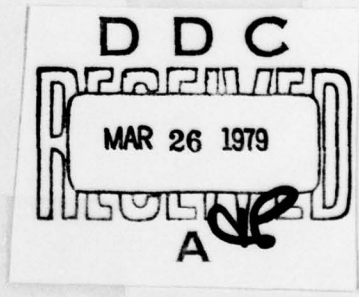

Approved for public release;
distribution unlimited.

78 12 26 249

EDITED TRANSLATION

FTD-ID(RS)T-1422-78

6 September 1978

MICROFICHE NR: *FD-78-C-001217*

CONTROLLED GAS-DISCHARGE DEVICE WITH A COLD CATHODE

By: I. I. Aksenov, V. A. Belous, and S. A. Smirnov

English pages: 5

Source: USSR Patent Nr. 313478, 30 November 1971,
PP. 1-4.

Country of origin: USSR

Translated by: Victor Mesenzeff

Requester: FTD/TQTD

Approved for public release; distribution unlimited.

ACCESSION for	
RTIS	Write Section <input checked="" type="checkbox"/>
ODC	Buff Section <input type="checkbox"/>
UNANNOUNCED	<input type="checkbox"/>
JUSTIFICATION	
BY	
DISTRIBUTION/AVAILABILITY CODES	
Dist.	AVAIL. and/or SPECIAL
A	

THIS TRANSLATION IS A RENDITION OF THE ORIGINAL FOREIGN TEXT WITHOUT ANY ANALYTICAL OR EDITORIAL COMMENT. STATEMENTS OR THEORIES ADVOCATED OR IMPLIED ARE THOSE OF THE SOURCE AND DO NOT NECESSARILY REFLECT THE POSITION OR OPINION OF THE FOREIGN TECHNOLOGY DIVISION.

PREPARED BY:
TRANSLATION DIVISION
FOREIGN TECHNOLOGY DIVISION
WP-AFB, OHIO.

U. S. BOARD ON GEOGRAPHIC NAMES TRANSLITERATION SYSTEM

Block	Italic	Transliteration	Block	Italic	Transliteration
А а	А а	A, a	Р р	Р р	R, r
Б б	Б б	B, b	С с	С с	S, s
В в	В в	V, v	Т т	Т т	T, t
Г г	Г г	G, g	У у	У у	U, u
Д д	Д д	D, d	Ф ф	Ф ф	F, f
Е е	Е е	Ye, ye; E, e*	Х х	Х х	Kh, kh
Ж ж	Ж ж	Zh, zh	Ц ц	Ц ц	Ts, ts
З э	З э	Z, z	Ч ч	Ч ч	Ch, ch
И и	И и	I, i	Ш ш	Ш ш	Sh, sh
Й й	Й й	Y, y	Щ щ	Щ щ	Shch, shch
К к	К к	K, k	Ъ ъ	Ъ ъ	"
Л л	Л л	L, l	Ы ы	Ы ы	Y, y
М м	М м	M, m	Ь ь	Ь ь	'
Н н	Н н	N, n	Э э	Э э	E, e
О о	О о	O, o	Ю ю	Ю ю	Yu, yu
П п	П п	P, p	Я я	Я я	Ya, ya

*ye initially, after vowels, and after ъ, ь; e elsewhere.
When written as ё in Russian, transliterate as yě or ě.

RUSSIAN AND ENGLISH TRIGONOMETRIC FUNCTIONS

Russian	English	Russian	English	Russian	English
sin	sin	sh	sinh	arc sh	sinh ⁻¹
cos	cos	ch	cosh	arc ch	cosh ⁻¹
tg	tan	th	tanh	arc th	tanh ⁻¹
ctg	cot	cth	coth	arc cth	coth ⁻¹
sec	sec	sch	sech	arc sch	sech ⁻¹
cosec	csc	csch	csch	arc csch	csch ⁻¹

Russian English

rot curl
lg log

CONTROLLED GAS-DISCHARGE DEVICE
WITH A COLD CATHODE

I. I. Aksenov, V. A. Belous, and
S. A. Smirnov.

This invention pertains to the controlled low-pressure gas-discharge devices with a cold cathode capable of transmitting high pulse currents and, especially, to the gas-discharge devices designed to operate in high-voltage installations as the activating and protecting elements.

There are controlled gas-discharge devices with a cold cathode which are filled with gas or vapor at low pressure. These devices are controlled by exciting the glow-discharge (for example, a high-frequency glow-discharge) in a chamber separated from the main discharge space by a cathode. The chamber is connected with the main discharge space through an opening in the cathode. A negative voltage pulse is fed to the starting electrode, which is in the form of a solid disc located in the chamber in front of the cathode, to start the device.

One of the drawbacks of the devices of this type is the necessity for the excitation of the keep-alive glow-discharge in the starting chamber. In the operation without the keep-alive glow-discharge the starting characteristics of the device worsen sharply and the lag time of activation and its dispersion increase considerably.

The device being proposed differs from the known in that the starting electrode is made in the form of one or several cylindrical

or prismatic cells arranged opposite to the openings in the cathode. The bases of the cells have openings on the side of the cathode. This improves the starting characteristics of the tube.

Figures 1 and 2 show two versions of construction of the device.

Figure 1 shows a device constructed with a single-cell starting electrode. Anode 1 has the shape of a disc and cathode 2 is a hollow cylinder. Base 3 of the cylinder, which faces the anode, has holes 4. The principle discharge gap 5 is between the anode and the base. Inside the cathode cavity 6 is a starting electrode 7, which also is a hollow cylinder. One of the bases of this cylinder is either completely open or it has a hole 8, as this is shown on the drawing. This base of the starting electrode faces the perforated base 3 of cathode 2. Lead 9 of the starting electrode passes through holes 10 in base 11 of cathode 2. The 12 and 13 are the leads of the anode and cathode, respectively.

The device is filled with gas or vapor under pressure which ensures the necessary electrical strength of the anode-cathode gap and which is determined by the left branch of the Paschen curve. The diameter of the holes and the width of the slits in the perforated base of the cathode must not exceed the width of the space between the anode and cathode, so that the penetration of the anode field into cavity 6 would be small and the effect of the holes and slits on the electrical strength of the device could be disregarded.

In the initial state operating voltage is applied between the anode and cathode; in this case, distribution of the electrical field is established in gap 5 which is close to uniform, while in cavity 6 the field is virtually absent. When a negative voltage pulse is fed to the starting electrode, a discharge, which is characteristic for a system with a hollow cathode, ignites in cavity 6. In this case the role of the hollow cathode is played by the starting electrode 7 and the role of the anode - by base 3. As is known, such systems are different from the systems with the usual solid electrodes by a lower potential of both the ignition and burning of the independent glow-discharge. The plasma of this discharge is distinguished by the increased concentration of electrodes along the axis of the system. Under certain conditions a dense electron beam

is formed along this axis. From cavity 6 the electrons get into the discharge gap 5 through holes 4, ionize the atoms (or molecules) of the working gas and cause a breakdown of the gap (in Fig. 1 the path of the electrons is shown by dashed lines). The discharge plasma filling the cavity 6 is an effective source of electrons during the period of formation and burning of the main discharge. The amount of electrons in the zone of openings 4, where they are captured by the anode field, also increases due to an intensive treatment of the surface of base 3 and of the walls of the openings by an ultraviolet radiation whose powerful source, as is known, is the discharge plasma in the hollow cathode. After the breakdown of the main gap 5 either a dense glow-discharge is established between anode 1 and cavity 6 of the cathode through holes 4 or a discharge of the type of a vacuum arc is established between the anode and the external surface of base 3, depending on the parameters of the external discharge circuit.

The shape of holes 4 does not play a significant part in the operation of the discharger. Thus, instead of round holes, base 3 can have slits of any shape or length. It is only necessary that the width of these slits did not exceed the width of the main discharge gap 5, from the considerations of the electrical strength of the device.

As follows from this description, the central hole in base 3 plays the main part in the breakdown process of the discharge gap 5. In the initial period the current passes mainly through this opening, into which the main portion of the electrons flows from the discharge plasma in cavity 6. Thus, on the whole, the time of formation of the principal discharge and the starting stability of the device depend on the diameter of this opening. The formation can be accelerated and the stability can be improved by increasing the diameter of the central opening. However, in this case, the electrical strength will decrease. This can be avoided by changing the construction of the starting electrode, as shown in Fig. 2. In this case the cavity of the starting electrode 7 is divided by partitions 14 into cells (the designations of rest of the elements, their shape, and purposes are the same as in Fig. 1). Each cell

forms an individual hollow cathode. When a negative voltage of sufficient magnitude is fed to electrode 7 a discharge is formed in each of its cells approximately in the same way as in the cavity of the starting electrode of the discharger described above. In this case a beam of electrodes flows from the depth of each cell which is directed to the base 3. If the openings in the base happen to be in the path of these beams, all beams get into the discharge gap 5 and elicit a breakdown of the latter simultaneously at several locations. It is obvious that in this construction of the discharger the perforation of base 3 must be accomplished in such a way that the openings would be in front of each cell of the starting electrode.

Object of the invention

The controlled gas-discharge device with a cold cathode which contains an anode and cathode in the form of a hollow cylinder or a prism with a perforated base facing the anode, and a starting electrode located in the cathode's cavity, *is distinguished* by the fact that, in order to improve the starting characteristics, the starting electrode is made in the form of one or several cylindrical or prismatic cells arranged opposite the openings in the cathode and whose bases are facing the cathode and which are completely open or have openings.

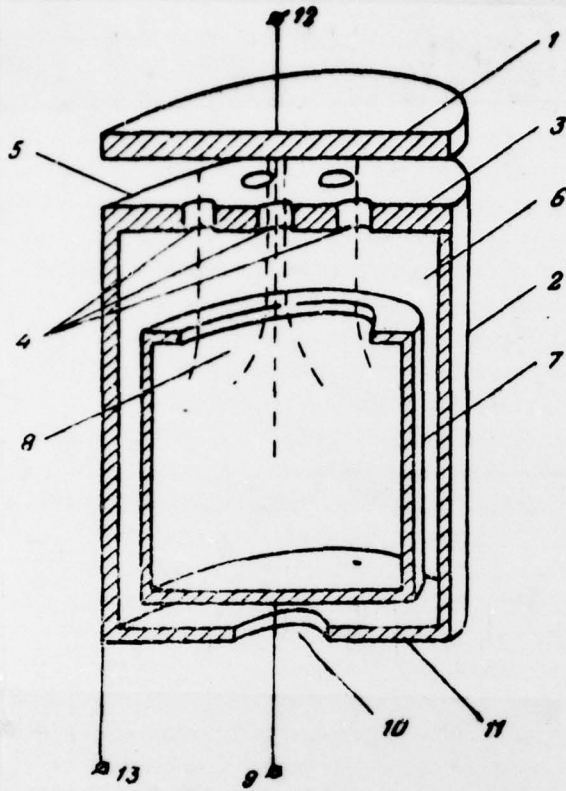

Fig. 1.

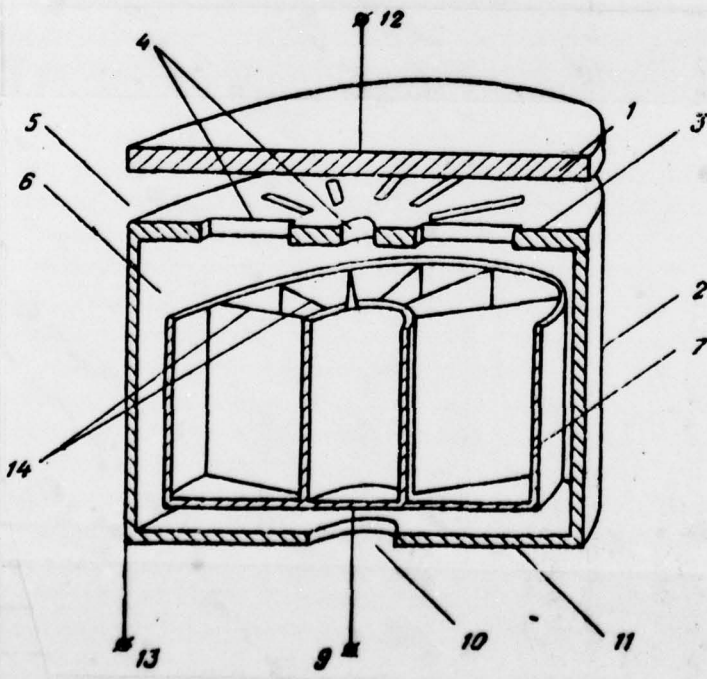

Fig. 2.

DISTRIBUTION LIST

DISTRIBUTION DIRECT TO RECIPIENT

<u>ORGANIZATION</u>	<u>MICROFICHE</u>	<u>ORGANIZATION</u>	<u>MICROFICHE</u>
A205 DMATC	1	E053 AF/INAKA	1
A210 DMAAC	2	E017 AF/RDXTR-W	1
B344 DIA/RDS-3C	9	E403 AFSC/INA	1
C043 USAMIIA	1	E404 AEDC	1
C509 BALLISTIC RES LABS	1	E408 AFWL	1
C510 AIR MOBILITY R&D	1	E410 ADTC	1
LAB/FIO		E413 ESD	2
C513 PICATINNY ARSENAL	1	FTD	
C535 AVIATION SYS COMD	1	CCN	1
C591 FSTC	5	ASD/FTD/NIIS	3
C619 MIA REDSTONE	1	NIA/PHS	1
D008 NISC	1	NIIS	2
H300 USAICE (USAREUR)	1		
P005 DOE	1		
P050 CIA/CRS/ADD/SD	1		
NAVORDSTA (50L)	1		
NASA/KSI	1		
AFIT/LD	1		