

AD-A066 599

ADVANCED RESEARCH RESOURCES ORGANIZATION WASHINGTON DC
DECISION AIDS IN ESTIMATING PERSONNEL REQUIREMENTS. (U)

F/G 5/9

UNCLASSIFIED

MAR 78 J M LEVINE, S M MALLAMAD
ARRO-3011-FR

N00123-77-C-0706
NL

1 OF 1
AD
A066599



END
DATE
FILMED

5-79

DDC

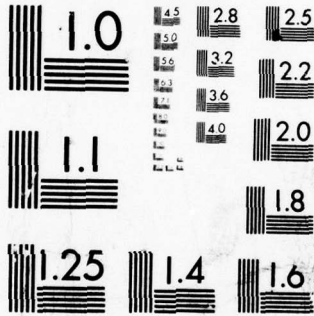

MICROCOPY RESOLUTION TEST CHART
NATIONAL BUREAU OF STANDARDS-1963-A

1

LEVEL II



ADVANCED
RESEARCH
RESOURCES
ORGANIZATION

4330 EAST-WEST HIGHWAY, WASHINGTON, D.C. 20014 ■ 202/986-9000

AD A0 66599

Decision Aids In Estimating Personnel Requirements

Jerrold M. Levine
Sharyn M. Mallamad
Edwin A. Fleishman

DDC FILE COPY

Final Report

March 1978

DDC
RECEIVED
MAR 30 1979
JCE

R78-3

a division of RESPONSE ANALYSIS CORPORATION, Princeton, New Jersey

79 03 26 002

REPORT DOCUMENTATION PAGE		READ INSTRUCTIONS BEFORE COMPLETING FORM
1. REPORT NUMBER	2. GOVT ACCESSION NO.	3. RECIPIENT'S CATALOG NUMBER
4. TITLE (and Subtitle)		5. TYPE OF REPORT & PERIOD COVERED
6 Decision Aids in Estimating Personnel Requirements .		9 Final Report. 15 Mar 1977-31 Mar 1978,
7. AUTHOR(s)		14 ARRO-3011-FR, ARRO-R78-3
10 Jerrold M./Levine, Sharyn M./Mallamad/ Edwin A./Fleishman		15 NO 0123-77-C-0706
9. PERFORMING ORGANIZATION NAME AND ADDRESS		10. PROGRAM ELEMENT, PROJECT, TASK AREA & WORK UNIT NUMBERS
-Advanced Research Resources Organization 4330 East-West Highway Suite 900 Washington, D. C. 20014		62763N, F55521, F55521022, 521.002.03.03
11. CONTROLLING OFFICE NAME AND ADDRESS		12. REPORT DATE
{ Design of Manned Systems Program Navy Personnel Research and Development Center San Diego, California 92152		11 March 1978
14. MONITORING AGENCY NAME & ADDRESS (if different from Controlling Office)		13. NUMBER OF PAGES
714 225-7650 225 6737		12 84 p.
15. SECURITY CLASS. (of this report)		15a. DECLASSIFICATION/DOWNGRADING SCHEDULE
Unclassified		
16. DISTRIBUTION STATEMENT (of this Report)		
Approved for public release; distribution unlimited		
17 ZF55521022 16 F55521		
17. DISTRIBUTION STATEMENT (of the abstract entered in Block 20, if different from Report)		
18. SUPPLEMENTARY NOTES		
19. KEY WORDS (Continue on reverse side if necessary and identify by block number)		
Abilities, Job Requirements, Job Analysis		
20. ABSTRACT (Continue on reverse side if necessary and identify by block number)		
<p>Three studies were carried out in order to evaluate the utility and reliability of a flow diagram designed to assess the ability requirements of jobs or tasks. The flow diagram was an easy to use systematic procedure for making a series of binary decisions as to whether or not each of 40 human abilities are essential to the successful conduct of a job or task. Results indicated that the instrument was consistently reliable (r=.47) for a variety of jobs and tasks. The uses of the instrument and recommendations for future research were discussed.</p> <p style="text-align: right;">use →</p>		

DECISION AIDS IN ESTIMATING PERSONNEL REQUIREMENTS

Jerrold M. Levine
Sharyn M. Mallamad
Edwin A. Fleishman

FINAL REPORT

Prepared under Contract to
Navy Personnel Research and Development Center
San Diego, California 92152

Contract No. N00123-77-C-0706

Principal Investigator
Edwin A. Fleishman

Approved for public release; distribution unlimited
Reproduction in whole or in part is permitted for
any purpose of the United States Government.

ADVANCED RESEARCH RESOURCES ORGANIZATION

March 1978

ACCESSION for	
NTIS	White Section <input checked="" type="checkbox"/>
DDC	Buff Section <input type="checkbox"/>
UNANNOUNCED	<input type="checkbox"/>
JUSTIFICATION _____	
BY _____	
DISTRIBUTION/AVAILABILITY CODES	
Dist.	AVAIL. and/or SPECIAL
A	

SUMMARY

Problem

There is a need for improved methods of assessing the personnel requirements of Navy jobs and tasks. One way to accomplish this objective is to identify the human abilities essential to successful job performance. With this knowledge personnel can be selected or trained to achieve a better match between their capabilities and the requirements of the job.

Approach

A comprehensive flow chart of 40 human abilities, including definitions, distinctions, and examples was developed. An analyst systematically proceeds through a series of binary decisions as to whether each of the abilities is required for performing a job or task. Three studies evaluated the reliability of the technique for different samples of analysts and types of job descriptions. A comparison was made with rating scale methods assessing the same abilities.

Results

The ability assessment diagrams proved to be reliable and superior to an alternate approach using rating scales to identify abilities required by tasks and jobs.

Conclusion

The diagrams should be used in conjunction with the rating scales; the former to identify required abilities and the latter to quantify the degree of involvement of each of the identified abilities.

Recommendation

Further research on the validity of the ability assessment diagrams should be carried out. The diagrams and ability rating scales provide a feasible technique to help establish personnel requirements for Navy jobs.

INTRODUCTION

There is a continuing need for better methods of assessing the personnel requirements of Navy jobs and tasks. In particular, methods are needed which will allow the achievement of a better match between the specific characteristics and requirements of such jobs and tasks and the abilities and capacities of individuals needed to perform these tasks effectively. More recent emphasis in the Navy for (a) the identification of more adaptive and flexible personnel and (b) more effective utilization and assimilation of women and minority groups into different job areas, further intensifies the need for procedures based on a clear rationale linking abilities and task requirements. Fleishman (1975a and 1975b) has described a comprehensive program of research which has attempted to develop such a rational empirically-based approach to the estimation of task requirements. In particular, this approach provides a descriptive language for translating information about the characteristics of tasks into estimates of ability requirements for effective performance.

The purpose of the present research was to assess the feasibility of a promising method of estimating personnel requirements, which was conceptualized in earlier work (Fleishman and Stephenson, 1972). The method employs flow diagrams in an easy to use systematic format that leads an analyst through a series of decisions as to whether each of 40 abilities is required for a job or task.

For the Navy, this work has several implications. First, there are some direct applications for improved methods of estimating and forecasting the ability requirements of existing and new Navy jobs. Second, the system developed provides a way of classifying Navy tasks and jobs into

categories of common requirements. A third and no less critical implication is that information provided would allow more effective use of human performance research data.

The rationale for the "ability requirements" approach to the assessment of task and job requirements has been detailed in earlier reports (Fleishman, 1964, 1967a, 1967b; Theologus, Romashko, and Fleishman, 1973). Briefly, the ability requirements approach describes a task in terms of the human abilities required to perform it, such that an entire task can be described in terms of a profile of basic abilities which accounts for performance on the task. If tasks were evaluated in terms of required abilities, then performance on new tasks could be predicted from tasks with similar ability requirements. Further, an individual's performance could be predicted on the basis of the abilities he possessed.

Substantial experimental effort has been devoted to the identification of the basic human abilities and their relation to different areas of human performance (cf. Fleishman, 1964; French, Ekstrom, and Price, 1963; Guilford, 1967). The result has been the establishment of sets of abilities encompassing much of the cognitive, perceptual, psychomotor, and physical areas of human performance.

The ability requirements approach has been shown to be useful for a variety of purposes in estimating personnel requirements, in predicting and assessing performance, and in predicting the effects of different procedures on human performance. With regard to estimating the ability requirements of jobs, diverse occupations such as firefighters, sanitation workers, police, telephone line-maintenance personnel, and supervisory and sales occupations have been analyzed (see e.g., Brumbach, Romashko,

Hahn, and Fleishman, 1974; Romashko, Brumbach, Fleishman, and Hahn, 1973, 1974a, 1974b; Fleishman, 1975c, 1976). In addition, a recent study by Zedeck (1976) indicated that the definition of job requirements through these methods improves the validity of test selection techniques.

A number of prototypical instruments have been developed for translating the ability approach into usable, feasible methods for estimating human performance requirements. Ability rating scales represent one such instrument. The rating scales include precise definitions of human abilities, distinctions from other abilities, and behaviorally anchored scales. An example taken from Fleishman (1975c) is presented in Figure 1. The scales permit a determination of whether or not an ability is required in a task or job and an estimate of the degree of its involvement.

The reliability of the rating scales was studied by Theologus, Romashko, and Fleishman (1973) and Theologus and Fleishman (1973). Reasonable reliability has been obtained across most of the individual ability scales when the mean rating from a group of judges was considered. However, interrater reliability among individual judges was not very high, and there was a tendency to overestimate the relevance of certain abilities to the task being analyzed.

The ability rating scales represent one attempt to estimate personnel requirements. The present research reports on the development and evaluation of an alternative approach which was designed to simplify the burden placed upon the analyst and hopefully to improve upon the reliability and validity with which ability requirements of tasks and jobs are determined. This approach involves the use of binary decision flow diagrams which serve as a decision aid to the analyst. He is led, step by

VERBAL COMPREHENSION

This is the ability to understand language. It is concerned with the understanding of individual words as well as words as they appear in context; i.e., in sentences, grammatical patterns and idiomatic phrases. In terms of communication, this ability is limited to the receiver of information; it does not apply to the sender or communicator.

VERBAL COMPREHENSION DISTINGUISHED FROM OTHER ABILITIES:

Understanding individual words and words in context.	vs.	Ideational Fluency <u>tion</u> of ideas relevant to a topic.
Characteristic of <u>receiver</u> of information.	vs.	Verbal Expression istic of <u>sender</u> of information.

Figure 1a. Example of an ability definition page used with the ability rating scales.

VERBAL COMPREHENSION

Requires the understanding of complex, detailed information which contains unusual words and phrases and involves fine distinctions in meaning among words.

• Understand in entirety a mortgage contract for a new home.

• Understand a newspaper article in the society section reporting on a recent party.

• Understand a comic book.

Requires a basic knowledge of language necessary to understand simple communications.

Figure 1b. Example of a rating scale page (to accompany the definition in Figure 1a) used with the ability rating scales.

step, through a series of yes/no decisions which result in the specification of the abilities required for the job or task. (See Figure 2 for an example of one of the prototype diagrams). An important difference between the two methods is that distinctions between abilities are made more apparent and the mutual exclusivity of several abilities are formalized in the flow diagrams.

The ability assessment diagrams are a supplement to the ability rating scales because unlike the scales, they do not permit an estimate of the amount of an ability required for job performance. The diagrams permit a determination only of whether or not an ability is required for task performance. As such, they are designed to be used in conjunction with the rating scales; the diagrams to identify abilities and the scales to quantify them.

The purpose of the present study was to complete the development of the binary decision flow diagrams, to evaluate their reliability, and to compare their use to previously developed ability rating scales.

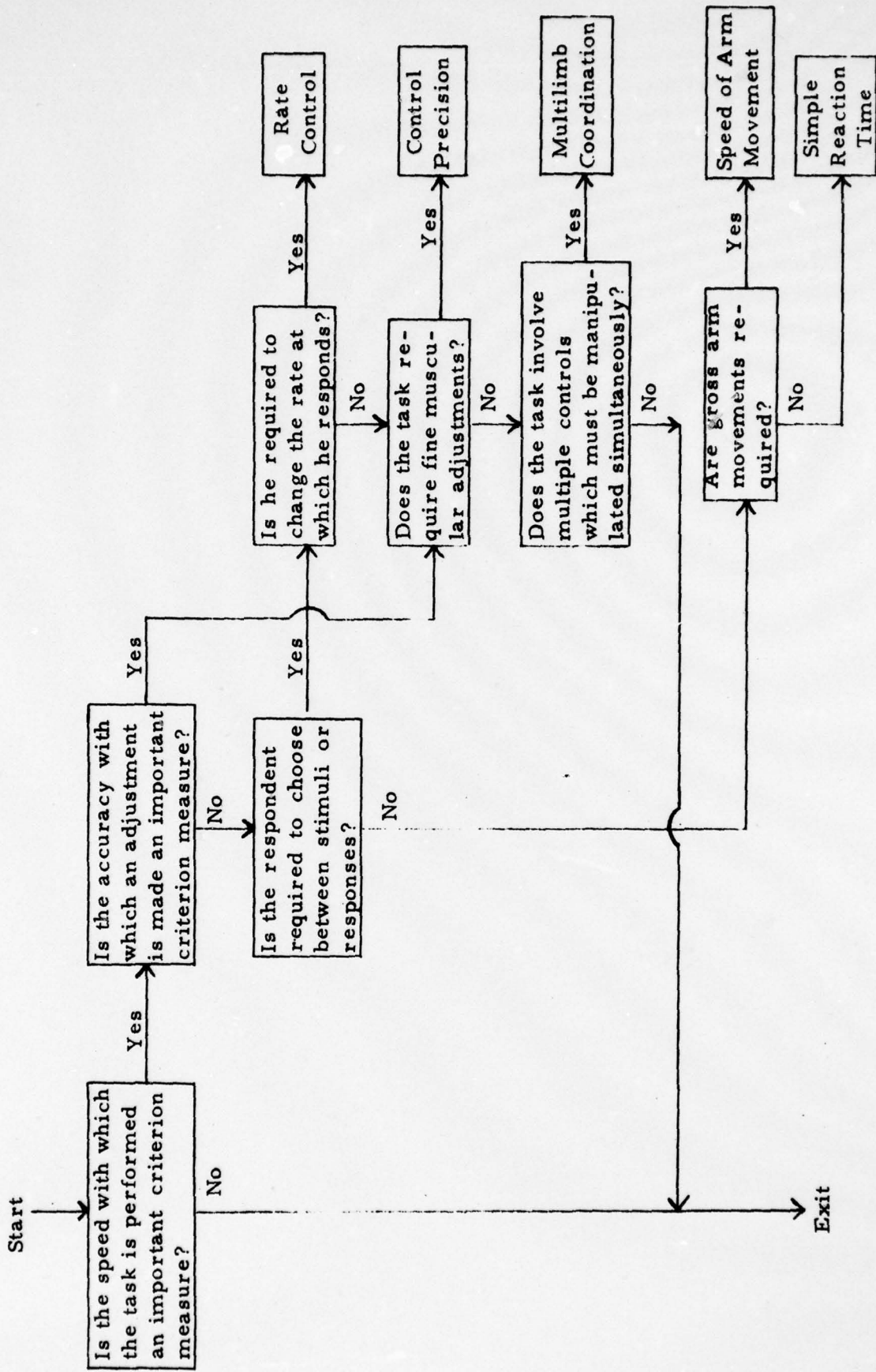

Figure 2. Early version of one binary decision diagram.

METHOD

Three studies were carried out using the ability assessment diagrams. The first was a preliminary effort designed as a try-out of the diagrams using task descriptions as the basis for assessment. The second and third studies evaluated the reliability of the diagrams using, in one study, a set of three Navy job descriptions and experienced Naval civilian personnel as analysts, and in the other study, a single familiar civilian occupation and graduate students as analysts. In both studies the abilities identified using the flow diagrams were compared with those identified using the rating scales.

Development of Diagrams

The assessment diagrams were developed from the definitions, distinctions, and examples of abilities given by Fleishman (1975c). The diagrams present ability concepts in a format designed to reduce the information processing and decision making demands on the analyst by requiring a series of simple binary decisions concerning whether or not an ability is required by a particular task or job. The diagrams appear in Appendix I entitled "Ability Assessment Manual." Instructions for using the manual are given in Appendix II.

The diagrams have a semantic and a structural component. The semantic information pertains to features of an ability that are essential in determining the presence or absence of the ability or that critically differentiate the ability from those similar to it. The semantic information is in the form of yes/no questions pertaining to only one feature of an ability, thereby minimizing the number of factors entering into a judge's decision. Exemplary activities previously scaled on the ability dimensions

(cf. Theologus and Fleishman, 1973; Fleishman, 1975c) are included as aids in clarifying the ability.

The structural dimension of the diagrams specifies and constrains the relationship between abilities. The structural features restrict which abilities are encountered by the analyst as potential ability requirements. The structure of the diagrams allows for three possible relationships between abilities.

- (i) Independent - the presence of an ability is unrelated to the presence of another ability.
- (ii) Mutually Exclusive - the presence of an ability means the absence of another ability.
- (iii) Dependent - the presence of an ability means the presence of another ability.

Study I

Subjects. Ten industrial psychology graduate students, familiar with the concepts of job analysis were recruited from a local university to serve as subjects and were paid for their services.

Materials. The experimental materials consisted of a preliminary version of the assessment diagrams and a set of task descriptions (cf. Appendix III). The content of the preliminary diagrams was the same as that of the Ability Assessment Manual (cf. Appendix I). The two versions differed slightly in that a number of decisions required by the preliminary version were later divided into two decisions in order to simplify judgments. The remaining differences were mostly editorial in nature.

The five tasks analyzed were specially prepared and restricted descriptions of basketball, driving, electronic troubleshooting, signal

identification, and sonar. The first four tasks were selected on the basis of their use in previous studies assessing the ability requirements of particular tasks (Theologus, Romashko, and Fleishman, 1973; Rose, Fingerman, Wheaton, Eisner, and Kramer, 1974; Wheaton, Eisner, Mirabella, and Fleishman, 1976). The sonar task was used as an example of a Navy-relevant activity.

Procedure. Subjects were instructed in the use of the diagrams. They were told to read each task description carefully and to complete the judging of one task before proceeding to the next. Subjects were free to refer back to the task descriptions at any time to refresh their memory. The entire procedure required approximately 1 1/2 hours.

Study II

Subjects. Participants were 48 research psychologists and personnel specialists at the U.S. Navy Personnel Research and Development Center (NPRDC), San Diego, California, whose experience in job analyses and related areas ranged from 2 months to 30 years. All subjects who volunteered their services were at least moderately familiar with the jobs being analyzed.

Materials. There were two types of ability assessment instruments used in this study. One was the Ability Assessment Diagrams (Appendix I) and one was the Ability Assessment Scales taken from the Manual for Ability Requirement Scales (Fleishman, 1975c). Each of the scales included an ability definition, a chart distinguishing the ability from others similar to it, and an anchored scale describing high and low levels of the ability with exemplar activities. The two instruments contained the same 40 abilities, presented in the same order.

Three Navy jobs were analyzed for ability requirements; Operations Specialist, Electronics Technician, and Machinery Repairman. The job descriptions were taken from official Navy doctrine and are of the type frequently encountered by Navy job analysts. The job descriptions appear in Appendix IV.

A brief screening questionnaire selected participants for the study on the basis of their familiarity with the jobs. Candidate subjects were asked to rate their familiarity with each of the jobs on a five-point scale ranging from very unfamiliar (1) to very familiar (5). Subjects whose familiarity ratings totalled at least eight points were included in the study.

Procedure. The experiment was carried out at the U.S. Navy Personnel Research and Development Center, San Diego, California. Half of the qualified subjects analyzed the jobs using the flow diagrams and the remaining half used the scales. Subjects were assigned to these two conditions at random, and the order in which the three jobs were analyzed was counterbalanced across subjects. Subjects performed the experiment on their own time but were instructed to complete the task in one sitting.

The instructions were appropriate to the type of assessment instrument used. Subjects were given a brief overview of the concept of ability requirements and the use of the diagrams or scales was explained. Subjects were told that they were rating the job as a whole. If an ability was necessary for one aspect or part of the job but not for another part of the job, the ability was still needed for the job. Subjects were further instructed that each selected ability must be necessary for a worker to possess in order to successfully perform the job. If they could imagine

the job being competently performed by a worker without the ability, then the ability was not necessary for the job, and should not be selected. The analysis of the three jobs required less than two hours.

Study III

Subjects. The subjects were 18 psychology graduate students from a local university who were paid for their participation.

Materials. The materials for Study III were the same as those used in Study II with the exception of the job descriptions. In this study, the descriptions of the three Navy jobs were replaced by one civilian job description--namely Air Traffic Controller. This occupation was considered to be highly familiar to the subjects. The description of the Air Traffic Controller job appears in Appendix IV.

Procedure. The procedure was identical to that of Study II with the exception that no screening for job familiarity was carried out. The study required approximately a half hour to complete.

RESULTS

Study 1

The abilities judged essential to each task were tabulated for each subject and the proportion of subjects selecting a particular ability was computed. These proportions are measures of rater agreement using the diagrams. Following Theologus, Romashko, and Fleishman (1973), "agreement" was operationally defined as 80 percent overlap among raters. That is, if at least 80 percent of the judges either select or do not select an ability, then agreement is reached with respect to the involvement of that ability in the task. An ability may thus be required, not required, or not agreed upon. Table 1 presents the proportion of abilities upon which agreement was reached. On the average, 71 percent of the abilities were agreed upon; of these, 53 percent judged not required and 18 percent judged required.

The ability requirements of two of the tasks, basketball and driving, had been examined previously by Theologus, Romashko and Fleishman (1973) using ability scales and these data are also presented in Table 1 for comparison. With respect to these two tasks, the diagrams produced more agreements than did the scales; 69 percent compared to 54 percent. More importantly, the distribution of agreements was quite different. The diagrams result in the specification of a larger number of "not required" abilities than is the case with the rating scales.

To better understand the difference in distribution of "agreements" between the diagrams and scales, the selection of abilities for the basketball and driving tasks was compared. This analysis, presented in Tables 2 and 3, revealed two facts. First, the abilities judged as required using the diagrams were generally a subset of the abilities judged

TABLE 1

Proportion of Abilities upon which an
80% Criterion of Agreement was Reached

Task	Decision	Diagrams	Scales
Basketball	Not Required	35.0	0.0
	Required	<u>35.0</u>	<u>60.0</u>
	Total	70.0	60.0
Driving	Not Required	40.0	3.0
	Required	<u>27.5</u>	<u>46.0</u>
	Total	67.5	49.0
Signal Identification	Not Required	70.0	
	Required	<u>10.0</u>	
	Total	80.0	
Electronic Troubleshooting	Not Required	55.0	
	Required	<u>10.0</u>	
	Total	65.0	
Sonar	Not Required	62.5	
	Required	<u>7.5</u>	
	Total	70.0	

TABLE 2

Classification of Abilities for Basketball Task

Diagrams	Scales		
	Required	No Agreement	Not Required
Required	Problem Sensitivity Deductive Reasoning Time Sharing Spatial Orientation Explosive Strength Stamina Extent Flexibility Dynamic Flexibility Gross Body Equilibrium Speed of Limb Movement Gross Body Coordination Choice Reaction Time	Selective Attention Visualization	
No Agreement	Wrist-Finger Speed Finger Dexterity Manual Dexterity Arm-Hand Steadiness	Memorization Originality Inductive Reasoning Information Ordering Multilimb Coordination Perceptual Speed	
Not Required	Flexibility of Closure Static Strength Dynamic Strength Rate Control Reaction Time	Category Flexibility Fluency of Ideas Number Facility Mathematical Reasoning Control Precision Speed of Closure	

TABLE 3

Classification of Abilities for Driving Task

Diagrams	Scales		
	Required	No Agreement	Not Required
Required	Problem Sensitivity Deductive Reasoning Time Sharing Selective Attention Perceptual Speed Spatial Orientation Multilimb Coordination Arm-Hand Steadiness Control Precision Rate Control	Memorization	
No Agreement	Extent Flexibility Speed of Limb Movement Wrist-Finger Speed Manual Dexterity Reaction Time Choice Reaction Time	Inductive Reasoning Visualization Static Strength Information Ordering Dynamic Flexibility Finger Dexterity	
Not Required		Originality Fluency of Ideas Number Facility Mathematical Reasoning Explosive Strength Dynamic Strength Stamina Gross Body Equilibrium Gross Body Coordination Flexibility of Closure Speed of Closure	Category Flexibility

as required using the scales. Second, abilities judged not to be required using the diagrams were very often the abilities that did not reach agreement using the scales. On the other hand, abilities that did not reach agreement with the diagrams were often judged to be required by the scales. It would appear that the diagrams result in a conservative shift in criteria for the identification of an ability as "required" for performing a task.

A second index of interrater agreement computed was the interclass correlation coefficient, r_k (Winer, 1965, p. 126). This coefficient estimates the reliability of the mean of k raters where reliability is defined as the true variance due to differences between abilities divided by the total variance (variance of abilities and variance of raters). For example, r_5 would be an estimate of the correlation obtained if the abilities selected by a group of five judges were correlated with the abilities selected by another random group of five judges, rating the same task.

Of particular interest is the statistic r_1 which reflects the reliability of a single judge's ratings. It estimates the average of the intercorrelations that would be obtained if the abilities selected by each rater were correlated with the abilities selected by every other rater.

The r_1 and r_5 statistics, calculated for each of the five tasks are presented in Table 4. The r_1 correlations are within an acceptable range with a mean of .46 and show an increase in reliability compared to the Theologus, Romashko, and Fleishman (1973) study. There r_1 was computed for each ability across tasks; averaging across abilities, the mean r_1 for the ability scales was .33. The mean reliability when a group of five raters used the diagrams (r_5) was .81.

One interpretation of the reliability data is that the judges are

TABLE 4

Interclass Correlation Coefficients for Study I

Task	r_1	r_5
Basketball	.53	.85
Driving	.51	.85
Signal Identification	.48	.83
Electronic Troubleshooting	.40	.77
Sonar	.39	.76

reasonably consistent in selecting the set of abilities which underlies a task. Another possibility is that there exists a general ability selection factor; that is, judges may be selecting the same set of abilities regardless of the task being analyzed. The second interpretation was eliminated by examining the intercorrelations between tasks for the group ability ratings for the 10 judges. This matrix of intercorrelations is shown in Table 5, where r_{10} values have been placed in the diagonal.

The fact that the correlations are not identical across tasks attests to the fact that judges are identifying a different set of abilities for each task. As expected, the r_{10} values, which estimate the correlation between the ratings of two groups of 10 judges rating the same task, are higher than any of the intercorrelations.

Study II

The proportion of subjects selecting each of the abilities for each Navy job description was computed separately for the diagram and scale procedures. Using the 80 percent criterion for agreement, abilities were classified as required or not required, and these tabulations are presented in Table 6.

The number of abilities agreed upon was higher across all jobs using the diagrams than using the scales. On the average, 59 percent of the abilities reached agreement using the diagrams compared to 46 percent with the scales. The pattern of responding was similar to that in Study I. Using the diagrams the average number of abilities judged "not required" far exceed the average number obtained using the scales (10 compared to 1.33); however, the average number of abilities judged as being "required"

TABLE 5

Intercorrelations of the Mean Ability Profile for 10 Judges
Among the Five Tasks. r_{10} 's appear in the Diagonal for Comparison.

Task	BB	DR	SI	ET	SON
Basketball (BB)	(.92)	.37	.17	.25	.14
Driving (DR)		(.91)	.33	.55	.39
Signal Identification (SI)			(.90)	.70	.77
Electronic Troubleshooting (ET)				(.87)	.61
Sonar (SON)					(.86)

TABLE 6

Proportion of Abilities upon which an
80% Criterion of Agreement was Reached

Job	Decision	Diagrams	Scales
Operations Specialist	Not Required	25.0	7.5
	Required	<u>35.0</u>	<u>47.5</u>
	Total	60.0	55.0
Machinery Repairman	Not Required	22.5	0.0
	Required	<u>37.5</u>	<u>35.0</u>
	Total	60.0	35.0
Electronics Technician	Not Required	27.5	2.5
	Required	<u>30.0</u>	<u>45.0</u>
	Total	57.5	47.5
Air Traffic Controller	Not Required	30.0	27.5
	Required	<u>37.5</u>	<u>30.0</u>
	Total	67.5	57.5

using the diagrams was slightly less than the number judged "required" using the scales (13.67 compared to 17.00).

Tables 7, 8, and 9 present the specific abilities judged as "required" and "not required" for each job using the diagrams and the scales as ability assessment instruments. The classification of abilities was consistent with the results in Study I. Generally, the abilities identified as required using the diagrams, were a subset of those identified as required by the scales. A criterion shift was evidenced again by the fact that differences in classification occurred when abilities judged as "required" using the scales were not agreed upon using the diagrams and abilities not agreed upon using the scales were judged as "not required" using the diagrams.

Interclass correlation coefficients for single judges (r_1) and for groups of five judges (r_5) were calculated for each Navy job for each procedure. The results are given in Table 10. Consistent with the agreement data, the diagrams have higher interrater reliability than the scales; the average intercorrelation for single judges was .47 and .24, respectively. The use of five judges produced higher reliabilities for both the diagrams and the rating scales; with generally higher reliabilities for the diagrams.

Study III

The analyses carried out for Study III were identical to those for Study II. The proportions for abilities reaching the 80 percent agreement criterion for the Air Traffic Controller job, used in this study, are presented in Table 6. The diagrams were shown to result in agreement among judges on 67.5 percent of the abilities. There was agreement on

TABLE 7

Classification of Abilities for Operations Specialist

Diagrams	Scales		
	Required	No Agreement	Not Required
Required	Oral Comprehension Written Comprehension Oral Expression Memorization Problem Sensitivity Deductive Reasoning Number Facility Time Sharing Flexibility of Closure Selective Attention Perceptual Speed Spatial Orientation Control Precision	Mathematical Reasoning	
No Agreement	Inductive Reasoning Information Ordering Speed of Closure Visualization Finger Dexterity Rate Control	Written Expression Originality Category Flexibility Fluency of Ideas Extent Flexibility Multilimb Coordination Wrist-Finger Speed Manual Dexterity Arm-Hand Steadiness Choice Reaction Time	
Not Required		Static Strength Trunk Strength Dynamic Flexibility Gross Body Equilibrium Speed of Limb Movement Gross Body Coordination Reaction Time	Explosive Strength Dynamic Strength Stamina

TABLE 8

Classification of Abilities for Machinery Repairman

Diagrams	Scales		
	Required	No Agreement	Not Required
Required	Written Comprehension Memorization Mathematical Facility Number Facility Selective Attention Visualization Multilimb Coordination Finger Dexterity Manual Dexterity Arm-Hand Steadiness Control Precision	Oral Comprehension Problem Sensitivity Deductive Reasoning Extent Flexibility	
No Agreement	Information Ordering Static Strength Rate Control	Oral Expression Written Expression Originality Category Flexibility Time Sharing Flexibility of Closure Perceptual Speed Spatial Orientation Dynamic Flexibility Gross Body Equilibrium Speed of Limb Movement Choice Reaction Time Wrist-Finger Speed	
Not Required		Inductive Reasoning Fluency of Ideas Speed of Closure Explosive Strength Dynamic Strength Trunk Strength Stamina Gross Body Coordination Reaction Time.	

TABLE 9

Classification of Abilities for Electronics Technician

Diagrams	Scales		
	Required	No Agreement	Not Required
Required	Oral Comprehension Written Comprehension Memorization Problem Sensitivity Deductive Reasoning Number Facility Selective Attention Finger Dexterity Manual Dexterity Arm-Hand Steadiness Control Precision	Mathematical Reasoning	
No Agreement	Oral Expression Inductive Reasoning Information Ordering Time Sharing Speed of Closure Perceptual Speed Extent Flexibility	Written Expression Originality Category Flexibility Fluency of Ideas Flexibility of Closure Spatial Orientation Visualization Gross Body Equilibrium Multilimb Coordination Wrist-Finger Speed	
Not Required		Static Strength Explosive Strength Dynamic Strength Trunk Strength Dynamic Flexibility Speed of Limb Movement Gross Body Coordination Rate Control Reaction Time Choice Reaction Time	Stamina

TABLE 10

Interclass Correlation Coefficients for Studies II and III

Job	Diagrams		Scales	
	r_1	r_5	r_1	r_5
Operations Specialist	.51	.84	.34	.72
Machinery Repairman	.43	.79	.14	.48
Electronics Technician	.48	.82	.25	.63
Air Traffic Controller	.46	.81	.42	.78

more abilities when analysts used the diagrams than when they used the scales (27 vs. 23 abilities, respectively).

The interclass correlation coefficients (r_1 and r_5) are shown in Table 10. The correlations support the high level of interrater agreement found using the diagrams in Study II. The reliability of the diagrams (.46) is nearly identical to the average reliability found for the three Navy jobs. For Air Traffic Controller, the reliability of the diagrams is slightly higher than that of the scales.

DISCUSSION

The ability diagrams developed in the present study have been shown to be a reliable instrument for assessing requirements of a variety of jobs. The reliability coefficients for a single judge's ratings were consistently good while those for a group of five judges were quite high. The fact that these reliability coefficients varied only slightly across the different jobs analyzed suggests that a stable index of reliability has been obtained.

In Study I, the diagrams were used to assess the ability requirements of five tasks. The results indicated that the diagrams could reliably identify these requirements. Interrater agreement for the diagrams proved to be as good as or better than that previously found using ability rating scales. Further, use of the diagrams resulted in agreement on which abilities were not required for task performance, a finding which did not occur with the rating scales. Intercorrelations of the selected abilities between tasks showed that the reliability of the diagrams was not the result of the judges selecting the same abilities regardless of the task; rather, judges were reliably identifying a unique configuration of abilities for each task description.

Studies II and III examined the reliability of the diagrams when assessing the ability requirements of jobs; three Navy jobs and one civilian job, respectively. A major difference between these studies and Study I was that jobs rather than tasks were being analyzed. Despite the complexity of the jobs and the marked differences between them the reliability of the diagrams was as good as that found using tasks. In addition, there was little variation in reliability indices across jobs.

The importance of these results is that the ability assessment diagrams reliably evaluate jobs, and it is jobs, consisting of many tasks, which ultimately prescribe personnel requirements.

The job descriptions in Studies II and III were also assessed using the ability scales. A comparison of the results of the two procedures revealed that the same conceptual framework was being used to assess ability requirements as indicated by the considerable overlap between the two procedures in the classification of individual abilities. The correspondence of these results supported the assumption that restructuring the ability information into binary choices did not alter the defining characteristics of the abilities.

Differences in the classification of individual abilities suggested that the use of the diagrams may have resulted in a conservative shift in the criteria used by judges in identifying an ability as "required" for the successful performance of a job. This shift in criteria could be responsible for the improved reliability of the diagrams since the major discrepancy between the diagram and rating scale procedures occurred for abilities judged "not required" for a job. Approximately the same number of abilities were "required" with the two procedures, while the diagrams produced nearly three times the number of "not required" abilities.

This criterion difference for determining the necessity of an ability may reflect two influences. First, critical features differentiating the abilities affect the structure of the diagrams, which in turn forces the judge to distinguish between abilities. These distinctions may be forgotten or overlooked using the ability rating scales despite their emphasis (cf. Figure 1). Second, the definitions at the

lower ends of the ability rating scales may be setting an overly lenient lower bound for what constitutes a "required" ability, since these imply that very low levels of abilities may be necessary. This difference in judge's criteria not only effects the reliability of the procedures but also the frequency of selecting abilities; judges using the scales select on the average 20 percent more abilities than judges using the diagrams.

It is also worth noting that the results reported in the present studies were obtained with a very heterogeneous subject population which was totally untrained in the use of the diagrams. The subjects had only a modest familiarity with the jobs being evaluated and this was highly variable. The present findings indicate that the use of highly trained specialists may not be necessary when such diagrams are used. However, the assessment of ability requirements of jobs is ordinarily carried out by a homogeneous group of highly trained specialists with a high degree of familiarity with the jobs being evaluated. In such an operational framework we would expect a more substantial increase in the reliability of the diagrams over that found in the present study.

CONCLUSION AND IMPLICATIONS

An instrument has been developed which permits relatively simple and rapid determinations of the ability requirements of tasks or jobs. This aid for estimating personnel requirements is basically a flow chart which systematically leads an analyst (judge) through a series of binary decisions as to whether each of 40 abilities is required for a specific task or job.

Over all tasks and jobs studied as representative the ability assessment diagrams proved to be reliable. In fact, the diagrams resulted in increased interrater reliability over the rating scale procedure. This may be due to the structure of the diagrams--they were constructed to elucidate the distinctions among the abilities. An important point to make is that the diagrams are a supplement to the rating scales because unlike the scales they do not permit an estimate of the amount of an ability required for task performance. The diagrams only permit a determination of whether or not an ability is required for task performance. As such, they are designed to be used in conjunction with the rating scales; the diagrams to identify abilities and the scales to quantify those which are identified.

The direct validation of job analysis information against independent measures is almost never done. These procedures are regarded as the starting point for many other personnel procedures. However, the system described lends itself to such validation and it is recommended that this be done. Such a determination is accomplished by comparing the abilities identified through use of the diagrams with ability profiles empirically determined to underlie successful job performance. This research is especially warranted by the finding that the use of the diagrams resulted

in the identification of a subset of abilities which were identified using the rating scales.

The utility of the ability assessment diagrams to the Navy lies in the potential for achieving a better match between specific characteristics and requirements of Navy jobs and the abilities and capacities of individuals needed to perform these jobs effectively. Instruments such as the one developed in the present study have direct application for improved methods of forecasting the ability requirements of existing and new Navy jobs. Additionally, the instrument and the underlying abilities rationale upon which it is based, provides a way of classifying tasks or jobs into categories of common requirements. Each of these applications provides inputs into personnel and training requirements and decisions for the Navy.

REFERENCES

- Brumbach, G. B., Romashko, T., Hahn, C. P., & Fleishman, E. A. Models for job analysis, test development and validation procedures. Final Report. Washington, D. C.: American Institutes for Research, 1974.
- Fleishman, E. A. Structure of measurement of physical fitness. Englewood Cliffs, New Jersey: Prentice-Hall, 1964.
- Fleishman, E. A. Development of a behavior taxonomy for describing human tasks: A correlational-experimental approach. Journal of Applied Psychology, 1967, 51, 1-10. (a)
- Fleishman, E. A. Performance assessment based on an empirically derived task taxonomy. Human Factors, 1967, 9, 349-366. (b)
- Fleishman, E. A. Toward a taxonomy of human performance. American Psychologist, 1975, 30, 1127-1149. (a)
- Fleishman, E. A. Taxonomic issues in human performance research. In W. T. Singleton & P. Spurgeon (Eds.), Measurement of human resources. New York: Halstead Press, 1975. (b)
- Fleishman, E. A. Development of ability requirement scales for the analysis of Bell Systems jobs. Bethesda, Maryland: Management Research Institute, 1975. (c)
- Fleishman, E. A. Development of ability requirement scales for the analysis of yellow page sales jobs in the Bell System. Bethesda, Maryland: Management Research Institute, 1976.
- Fleishman, E. A., & Stephenson, R. W. Development of a taxonomy of human performance: A review of the third year's progress. JSAS Catalog of Selected Documents in Psychology, 1972, 2, 40-41.
- French, J. W., Eckstrom, R. B., & Price, L. A. Manual for kit of reference tests for cognitive factors. Princeton, New Jersey: Educational Testing Service, June 1963.
- Guilford, J. P. The nature of human intelligence. New York: McGraw-Hill, 1967.
- Romashko, T., Brumbach, G. B., Fleishman, E. A., & Hahn, C. P. The development of a procedure to validate physical tests: Physical requirements of the sanitation man's job. (Technical Report 1). Washington, D. C.: American Institutes for Research, 1973.
- Romashko, T., Brumbach, G. B., Fleishman, E. A., & Hahn, C. P. The development of a procedure to validate physical tests: Physical requirements of the parking enforcement agent's job. (Technical Report 2). Washington, D. C.: American Institutes for Research, 1974. (a)

- Romashko, T., Brumbach, G. B., Fleishman, E. A., & Hahn, C. P. The development of a procedure to validate physical tests: Physical requirements of the fireman's job. (Technical Report 3). Washington, D. C.: American Institutes for Research, 1974. (b)
- Rose, A. M., Fingerman, P. W., Wheaton, G. R., Eisner, E., & Kramer, G. Methods for predicting job ability requirements: II. Ability requirements as a function of changes in the characteristics of an electronic fault-finding task. Washington, D. C.: American Institutes for Research, 1974.
- Theologus, G. C., & Fleishman, E. A. Development of a taxonomy of human performance: Validation study of ability scales for classifying human tasks. JSAS Catalog of Selected Documents in Psychology, 1973, 3, 29. (Ms. No. 326)
- Theologus, G. C., Romashko, T., & Fleishman, E. A. Development of a taxonomy of human performance: A feasibility study of ability dimensions for classifying human tasks. JSAS Catalog of Selected Documents in Psychology, 1973, 3, 25-26. (Ms. No. 321)
- Wheaton, G. R., Eisner, E., Mirabella, A., & Fleishman, E. A. Ability requirements as a function of changes in the characteristics of an auditory signal identification task. Journal of Applied Psychology, 1976, 61, 663-676.
- Winer, B. J. Statistical principles in experimental design. New York: McGraw-Hill, 1962.
- Zedeck, S. Validation of physical abilities tests for PT&T craft positions. (AT&T Research Report No. 1). 1976.

APPENDIX I

ABILITY ASSESSMENT MANUAL

ABILITY ASSESSMENT MANUAL

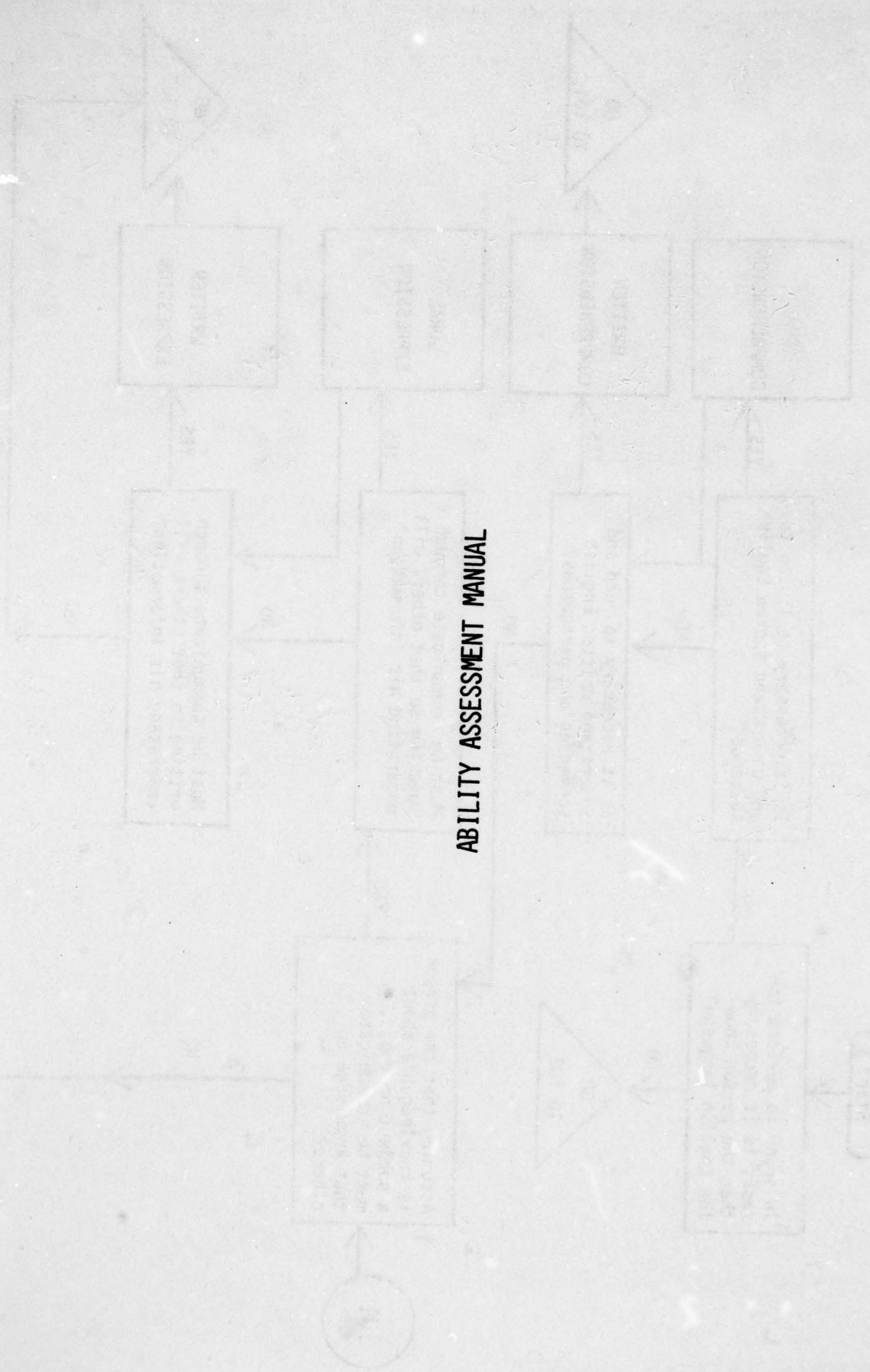

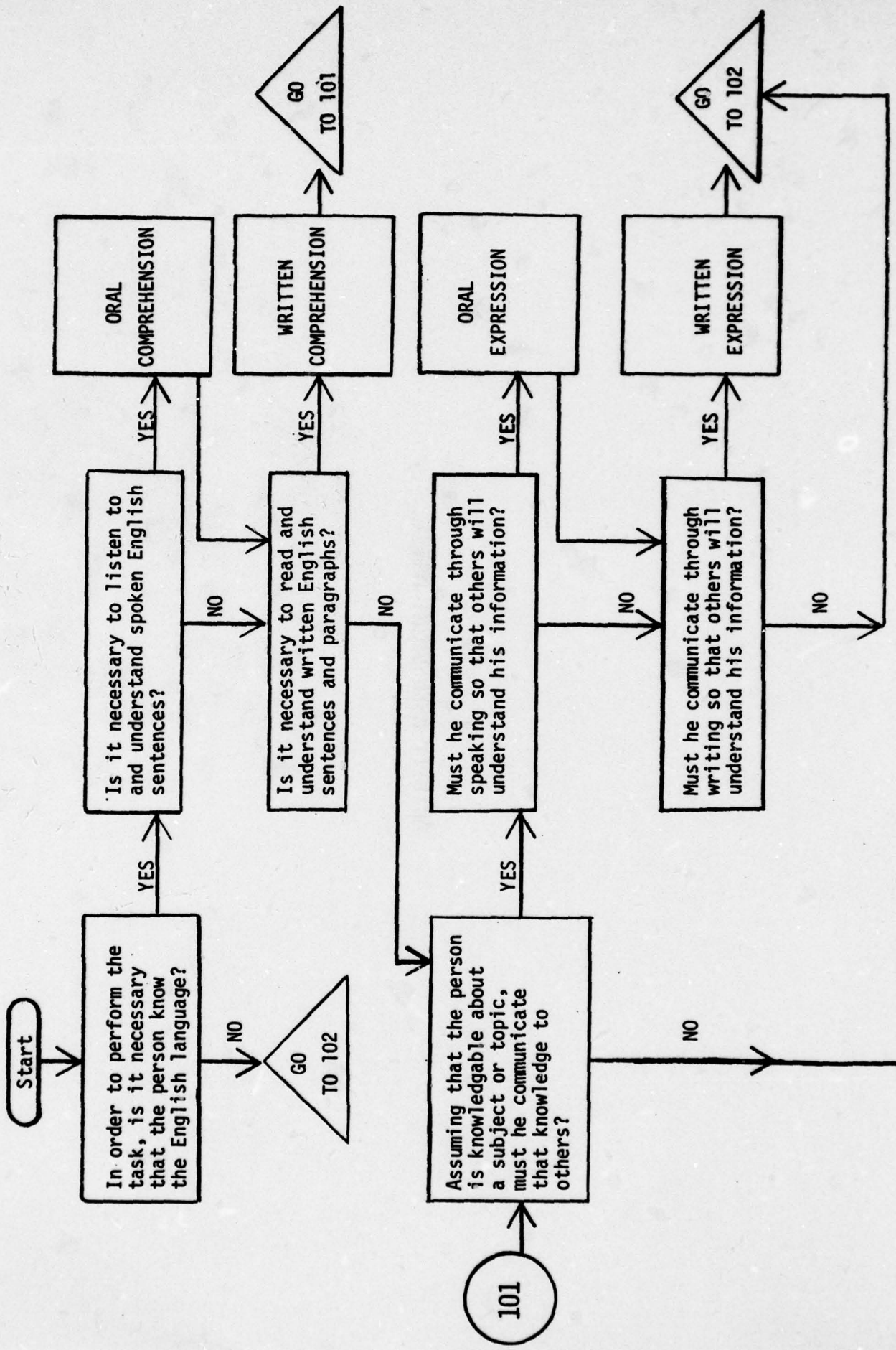

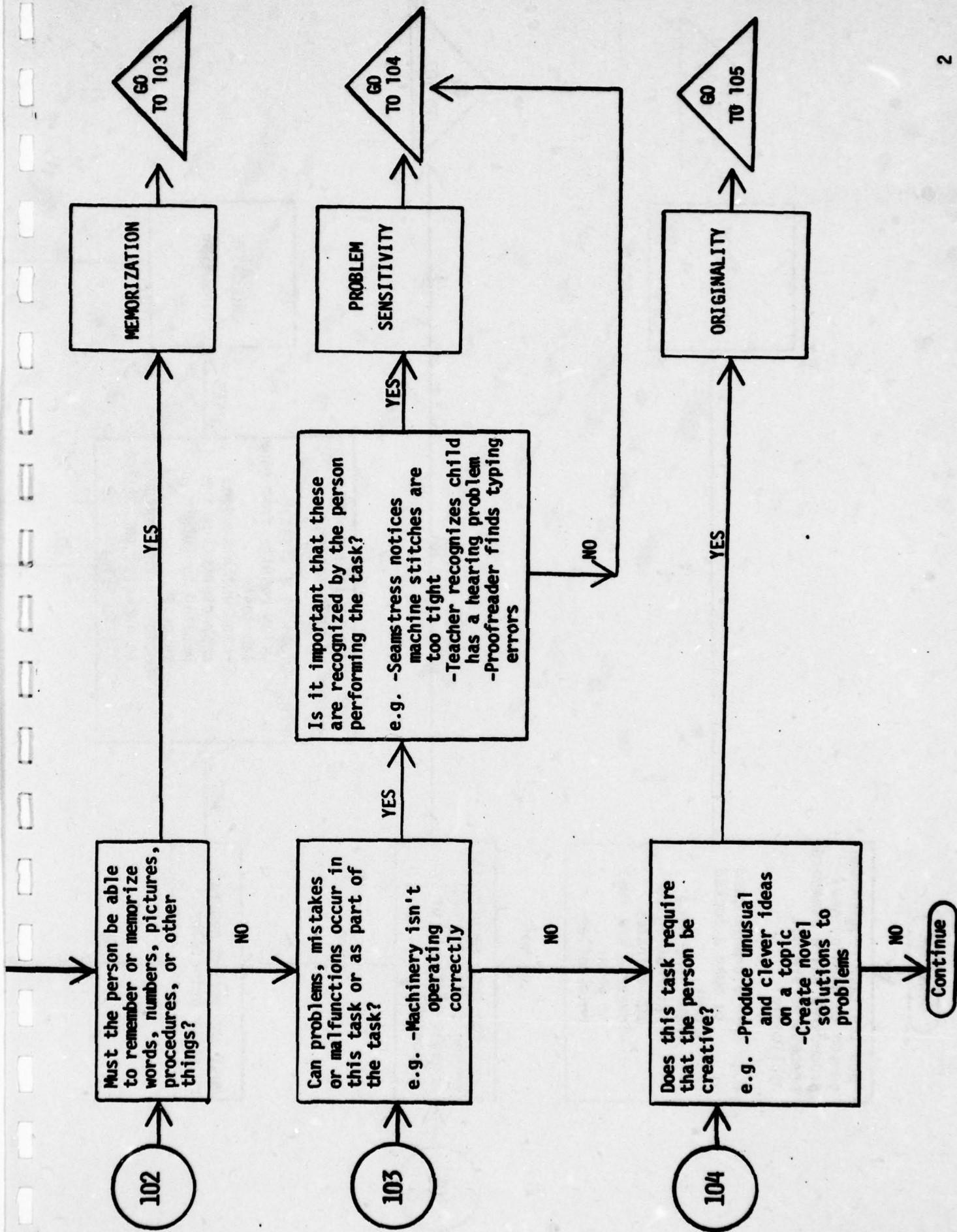

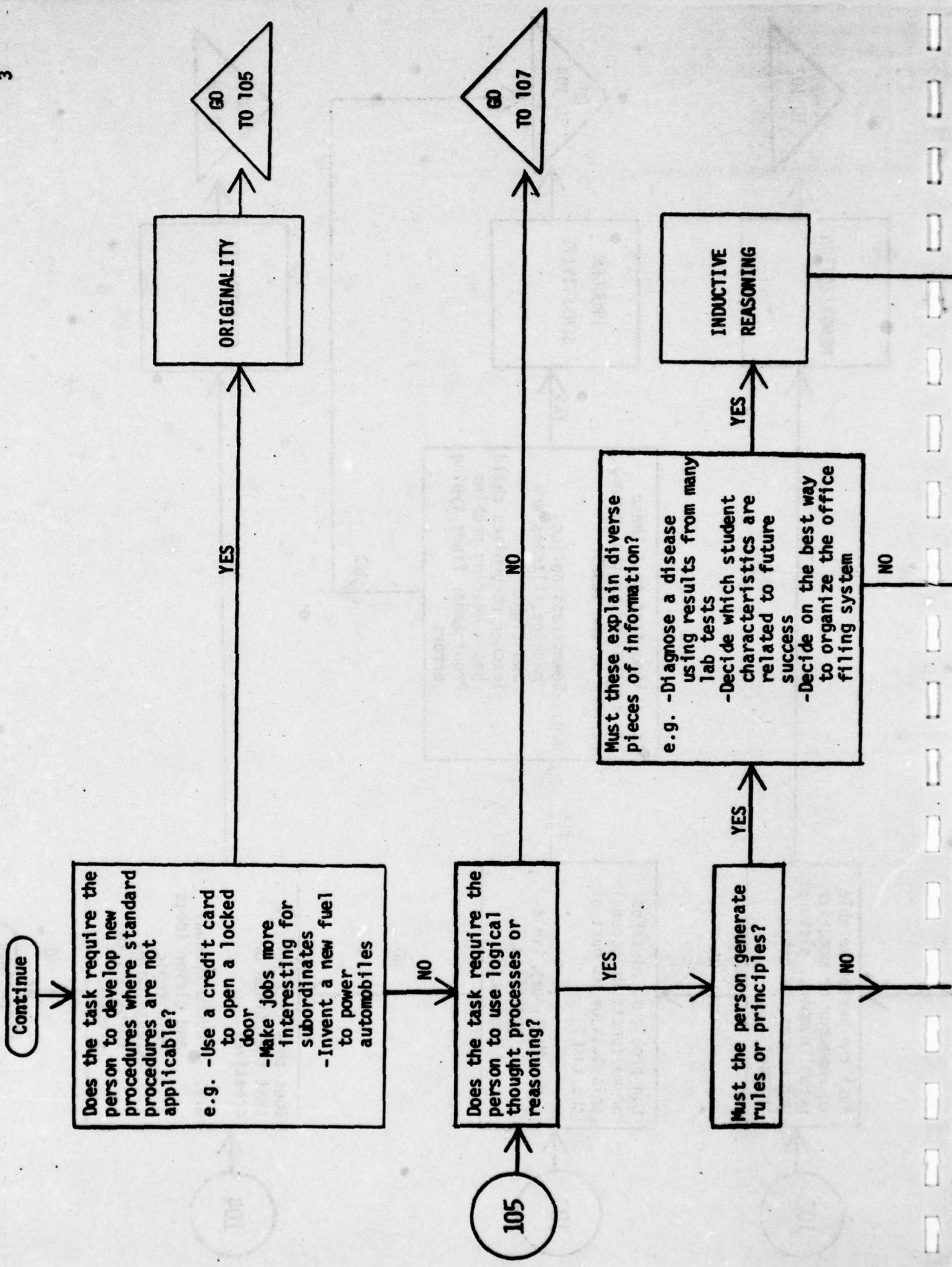

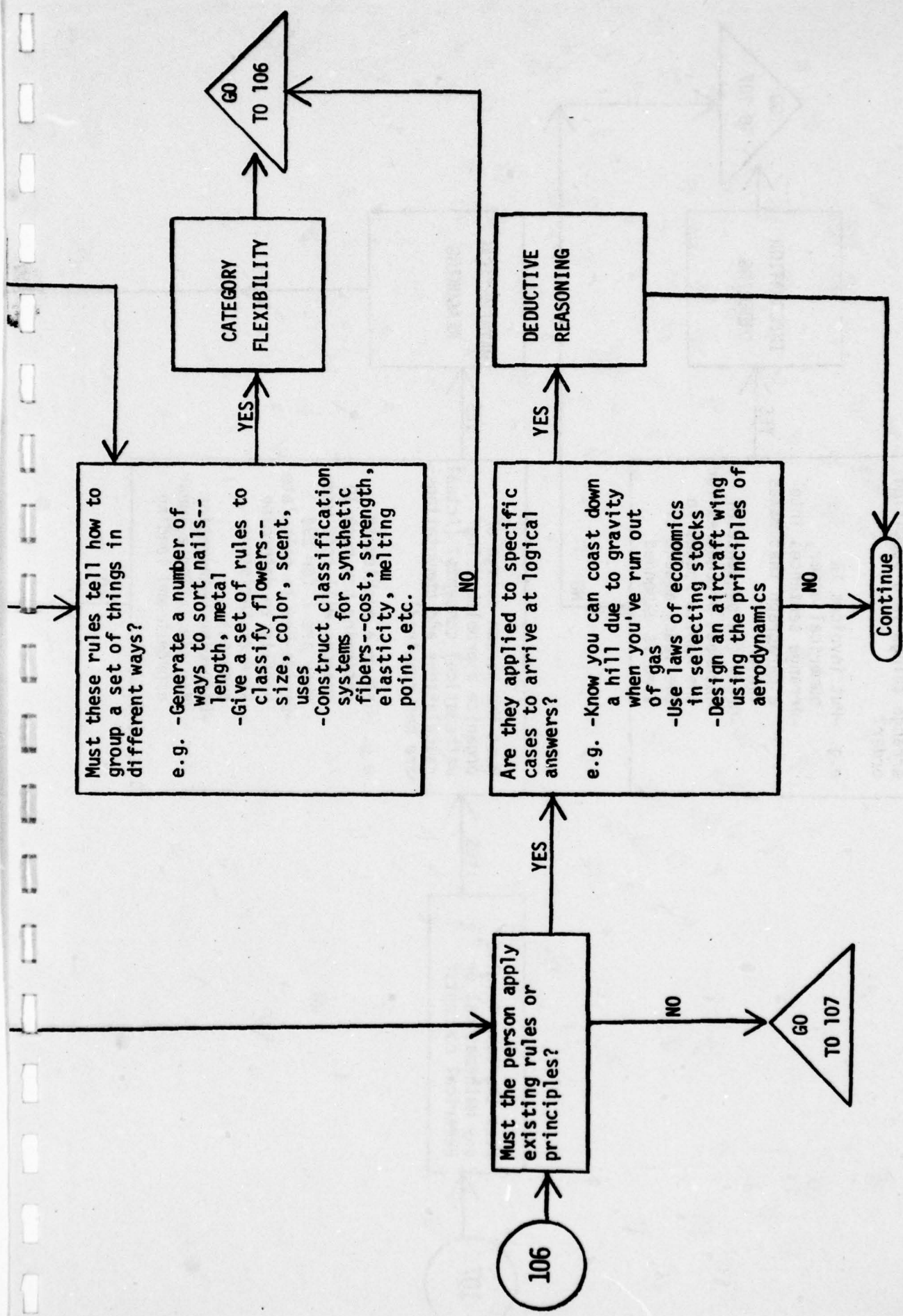

Continue

Are they used to order or arrange things in a specified order?
e.g. -Put invoices in numerical order
-Arrange sentences into a paragraph that makes sense
-Order the sequence of checkout procedures for the Apollo rocket so the least amount of time is expended

INFORMATION ORDERING

GO TO 107

Does the task involve any mathematical or numerical concepts?

Must the person design or organize a problem using mathematical concepts? (Actual calculations and computations are not required)
e.g. -Set up a problem to determine how much 10 oranges will cost when they are 2 for 29¢
-Decide how to calculate profits to determine size of Christmas bonuses
-Determine mathematics for simulating a lunar approach and landing

MATHEMATICAL REASONING

107

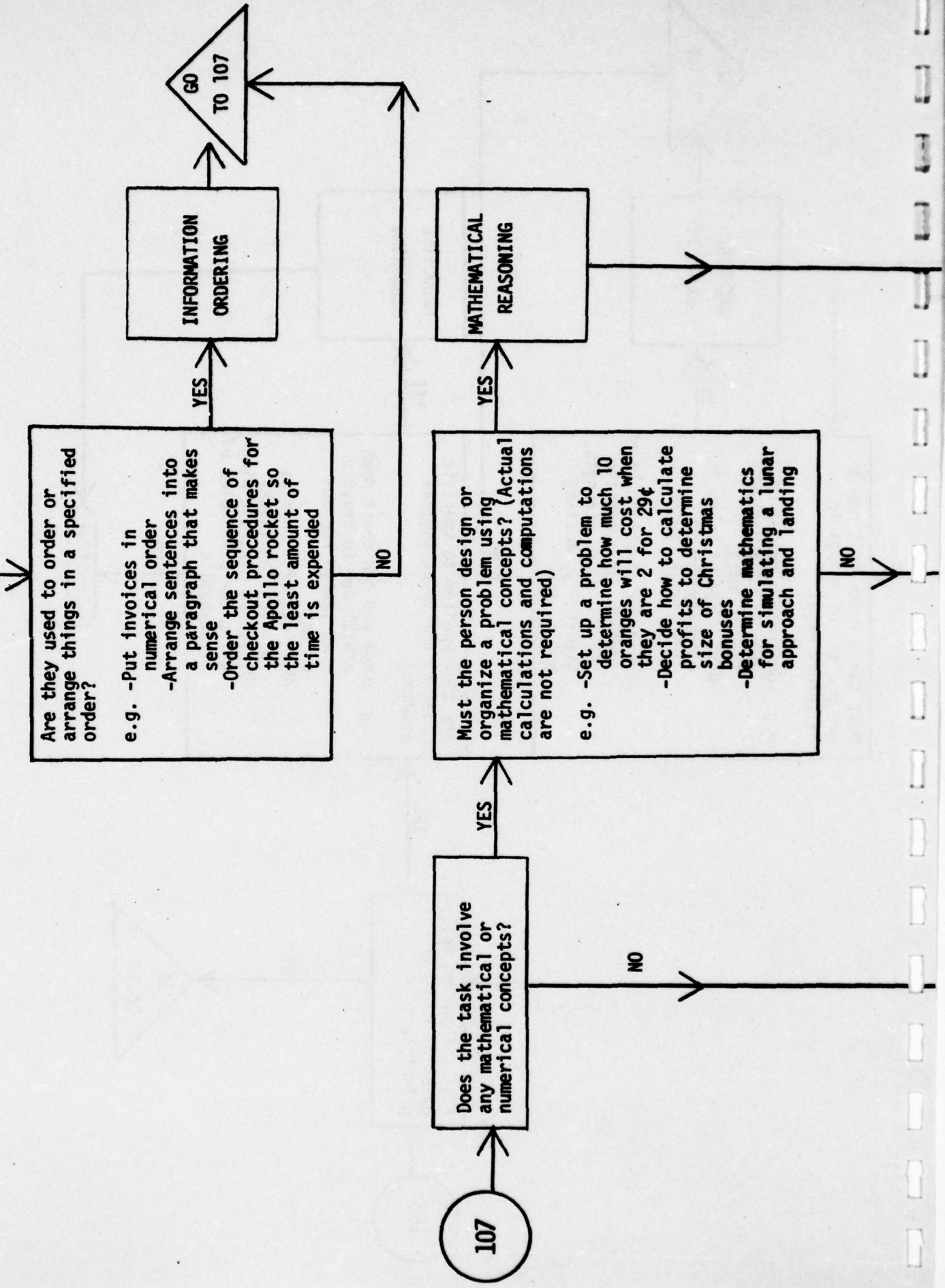

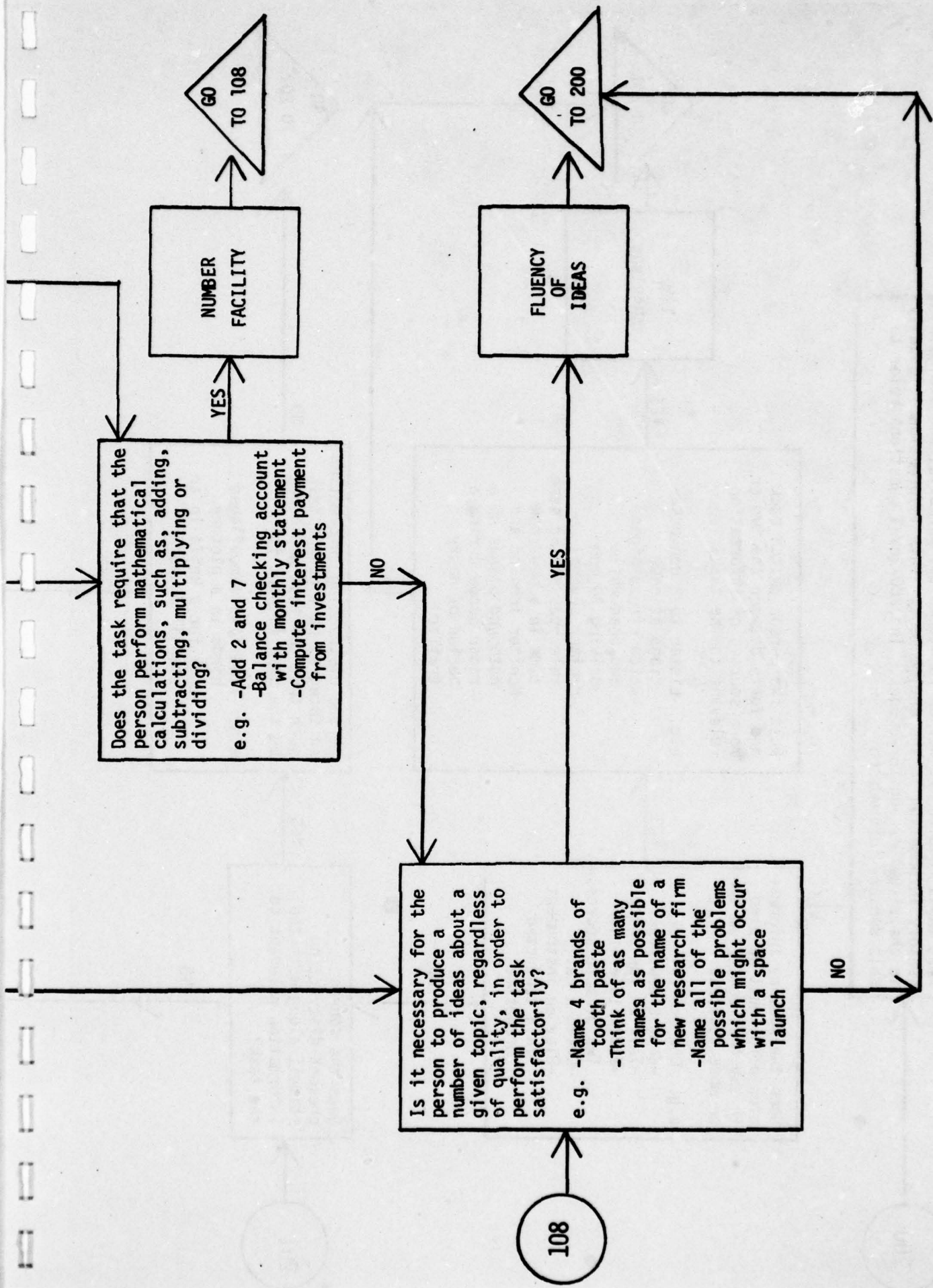

108

Most tasks require the person to attend to, perceive, and evaluate sensory information in the environment. This information is usually in the visual or auditory modes. The 200-level questions refer to this sensory information.

200

Does the sensory information which must be used in the task come from two or more sources?
 e.g. One source—
 -Read a newspaper
 -Talk on the phone
 -Watch television
 Two or more sources—
 -Drive a car
 -Play an instrument in a conducted orchestra

Must the person switch back and forth between the two or more sources of information relevant to the task?
 e.g. -Listen to 2 conversations at once
 -Watch street signs and road while driving 30 mph
 -Monitor several teletypes at the same time in a newsroom
 -Monitor inbound and outbound planes on a radar scope during a period of heavy traffic

TIME SHARING

GO TO 201

Does the source present distracting stimuli along with the information relevant to the task?

Is the distracting information an integral part of the task such that the task would not be the same without it?
 e.g. -Find five camouflaged birds in a picture
 -Look for a knife in an utensil drawer

201

GO TO 202

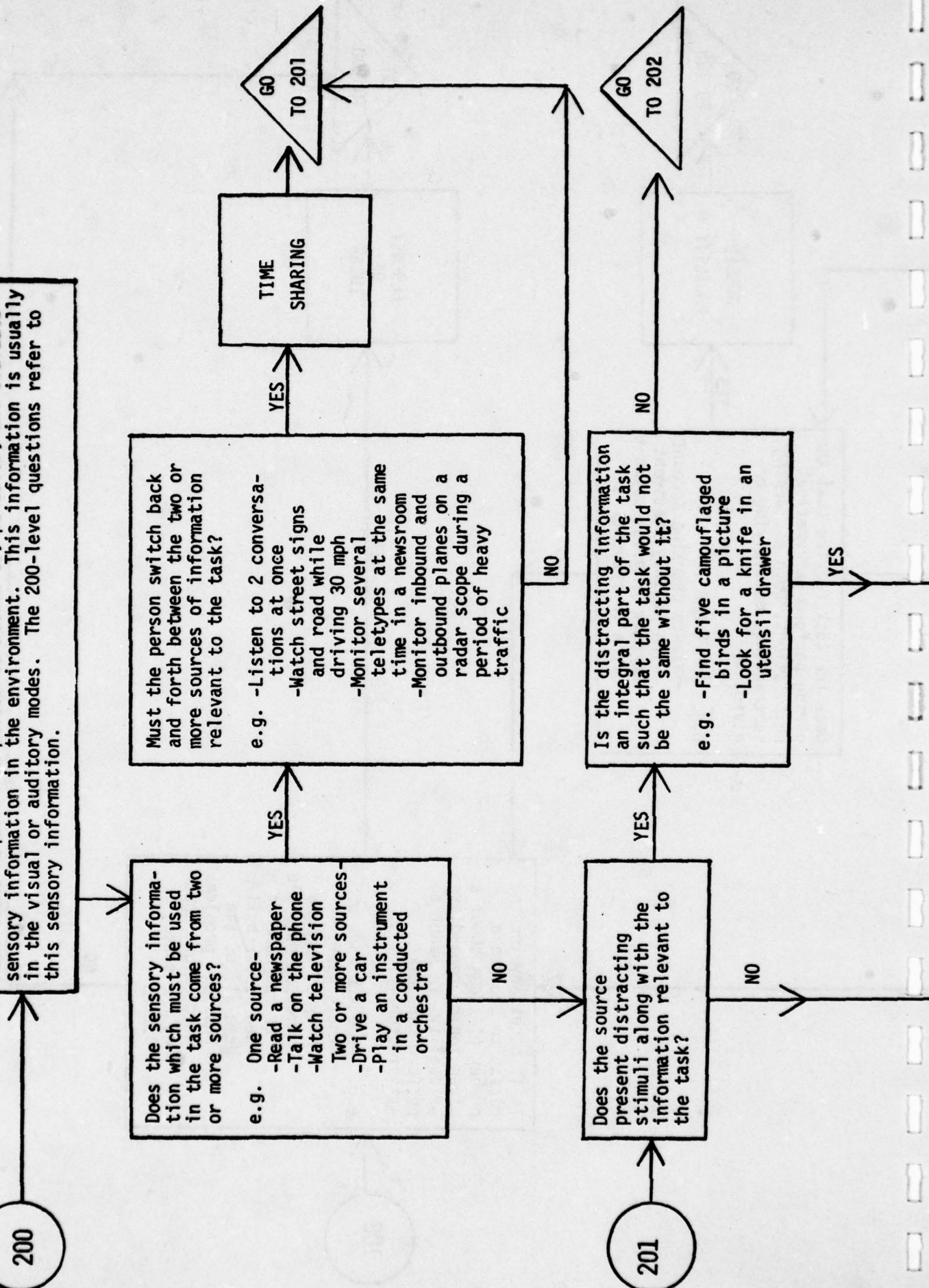

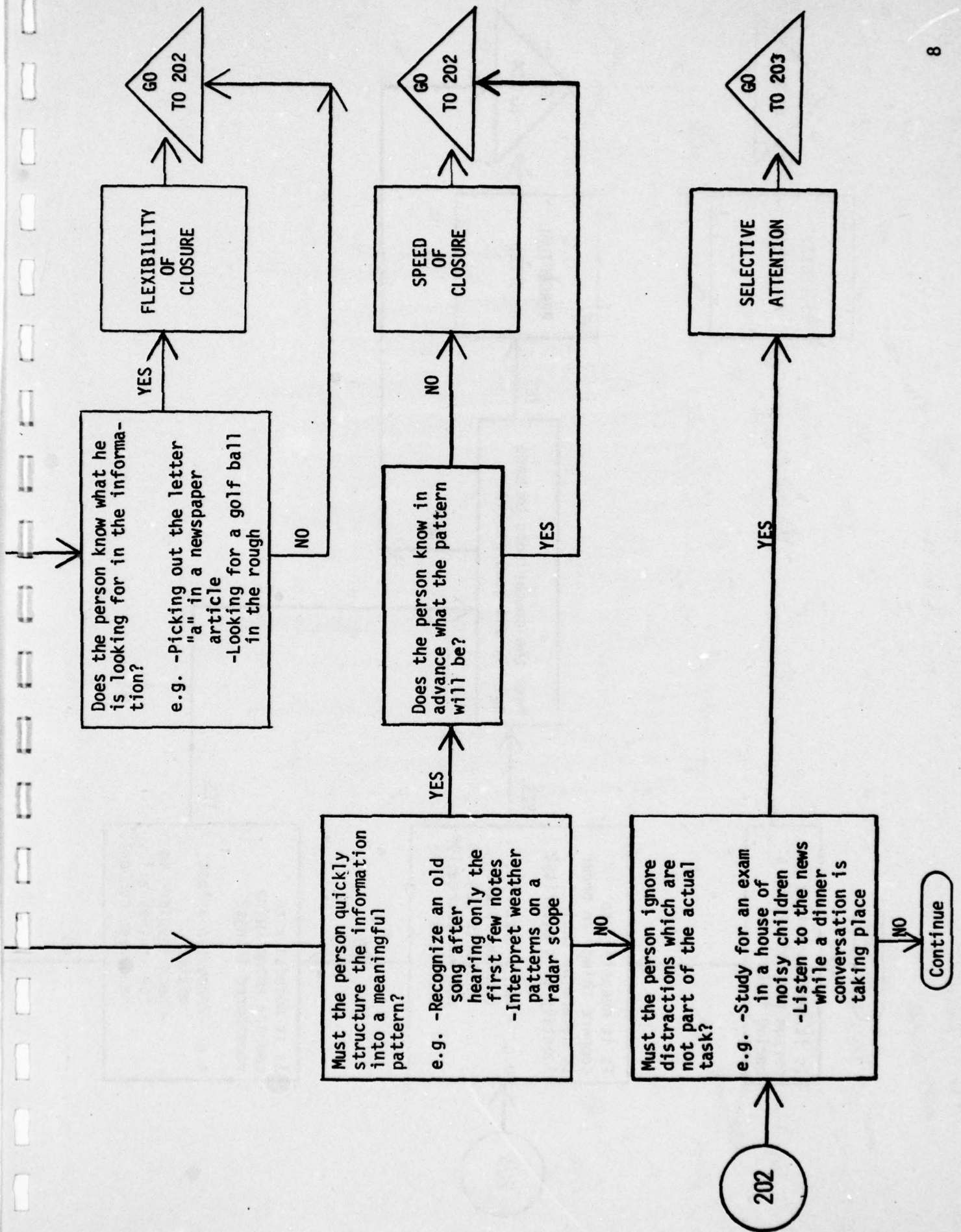

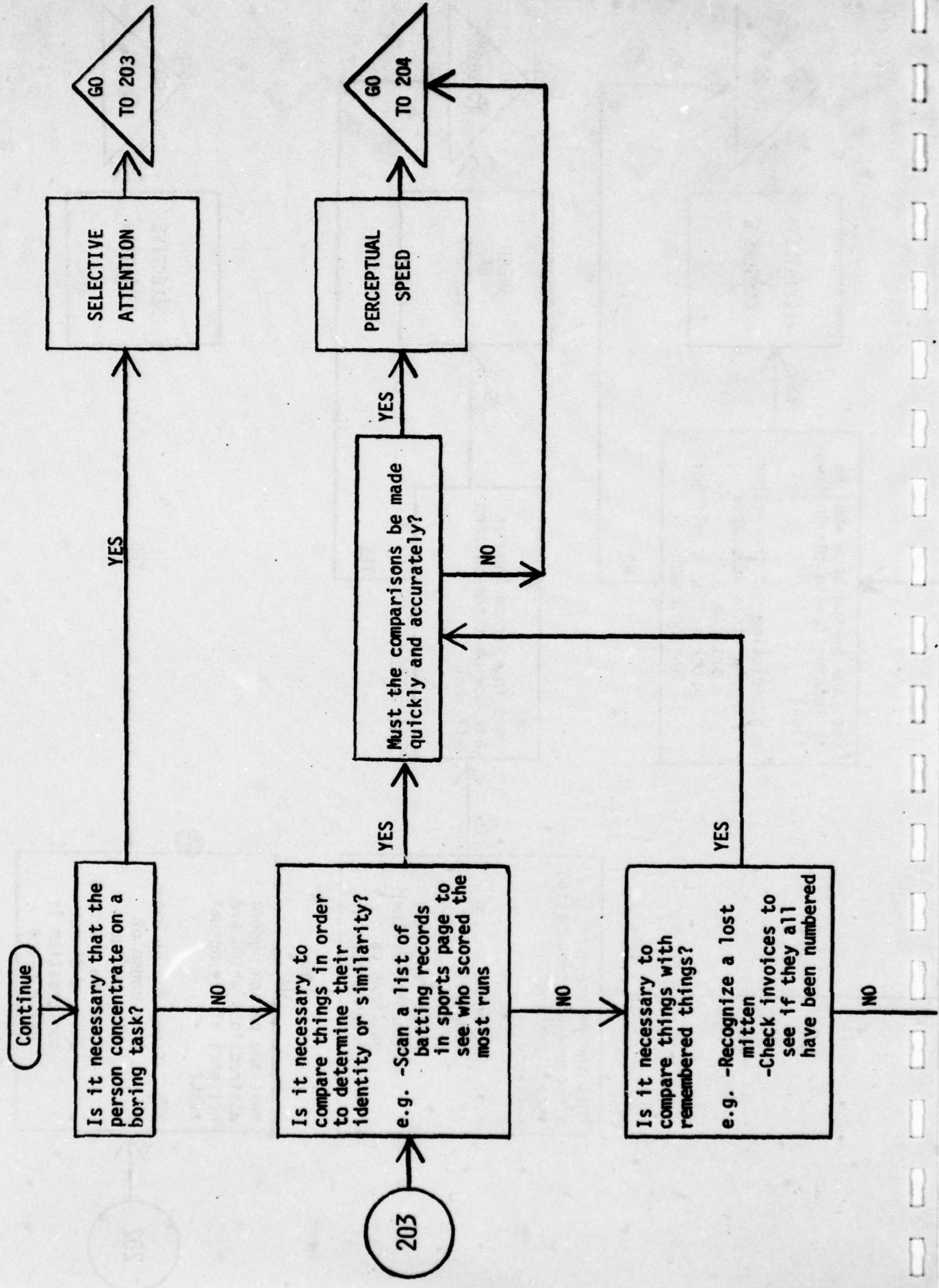

204

Is information about location important in the performance of the task?

Should the person know his location in relation to the location of objects?
e.g. -Locate your position on a road map
-Be aware of your orientation in a gravity-free environment like a spacecraft

Should the person know the location of objects in relation to his own location?
e.g. -Find your way through a dark room without bumping into anything

SPATIAL ORIENTATION

GO TO 205

Continue

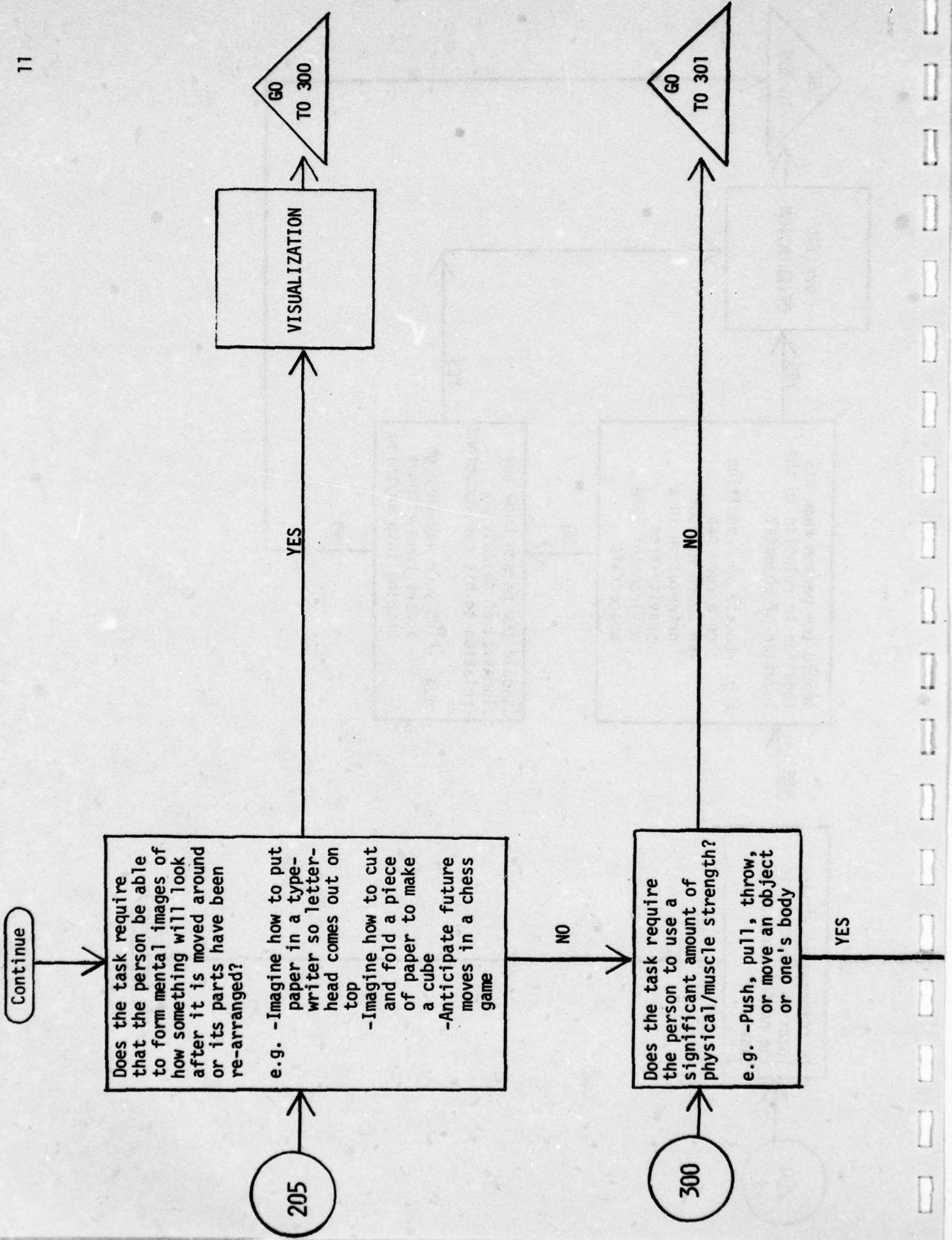

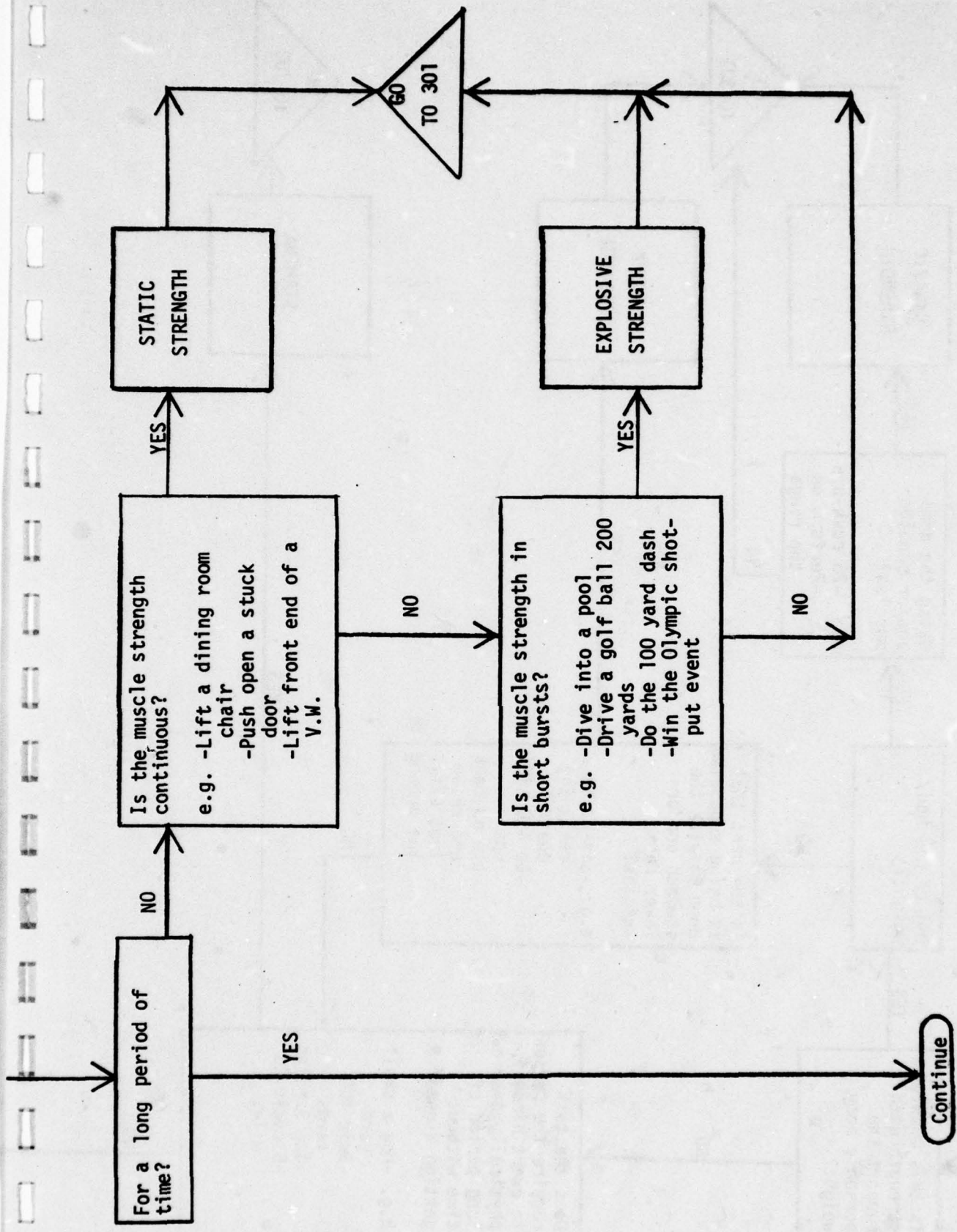

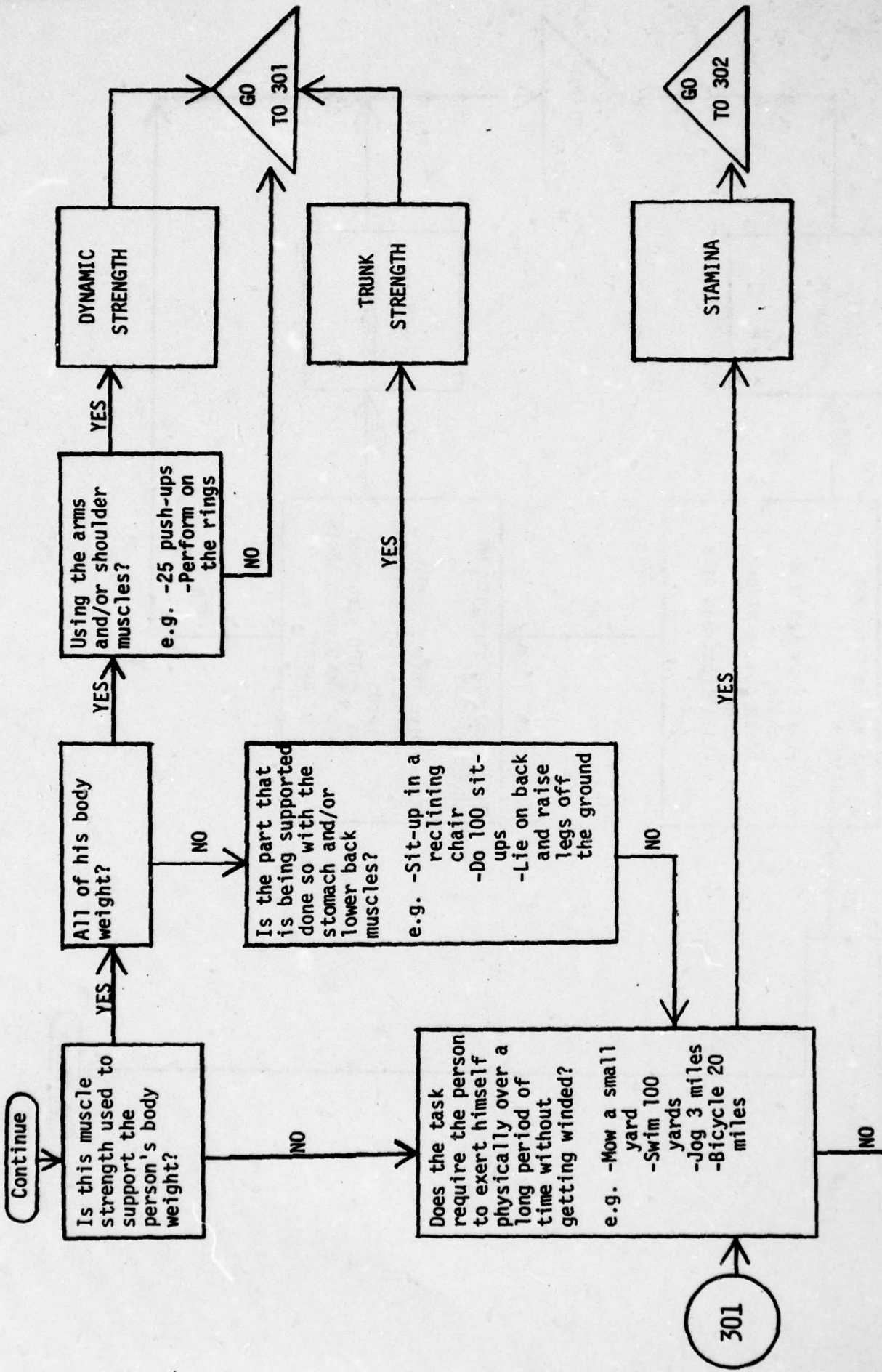

Does the task require the person to be flexible-- such that he must be able to bend, stretch, twist, or reach out with the body, arms and/or legs?
e.g. -Reach for a soda in the back of the refrigerator
-Touch your toes
-Do the splits
-Win a limbo championship

302

EXTENT FLEXIBILITY

Must the flexible movements be made quickly and repeatedly?
e.g. -Fill a bag with shells at the seashore
-Shovel coal into a furnace
-Swim 200 yards of the butterfly stroke

DYNAMIC FLEXIBILITY

GO TO 303

Continue

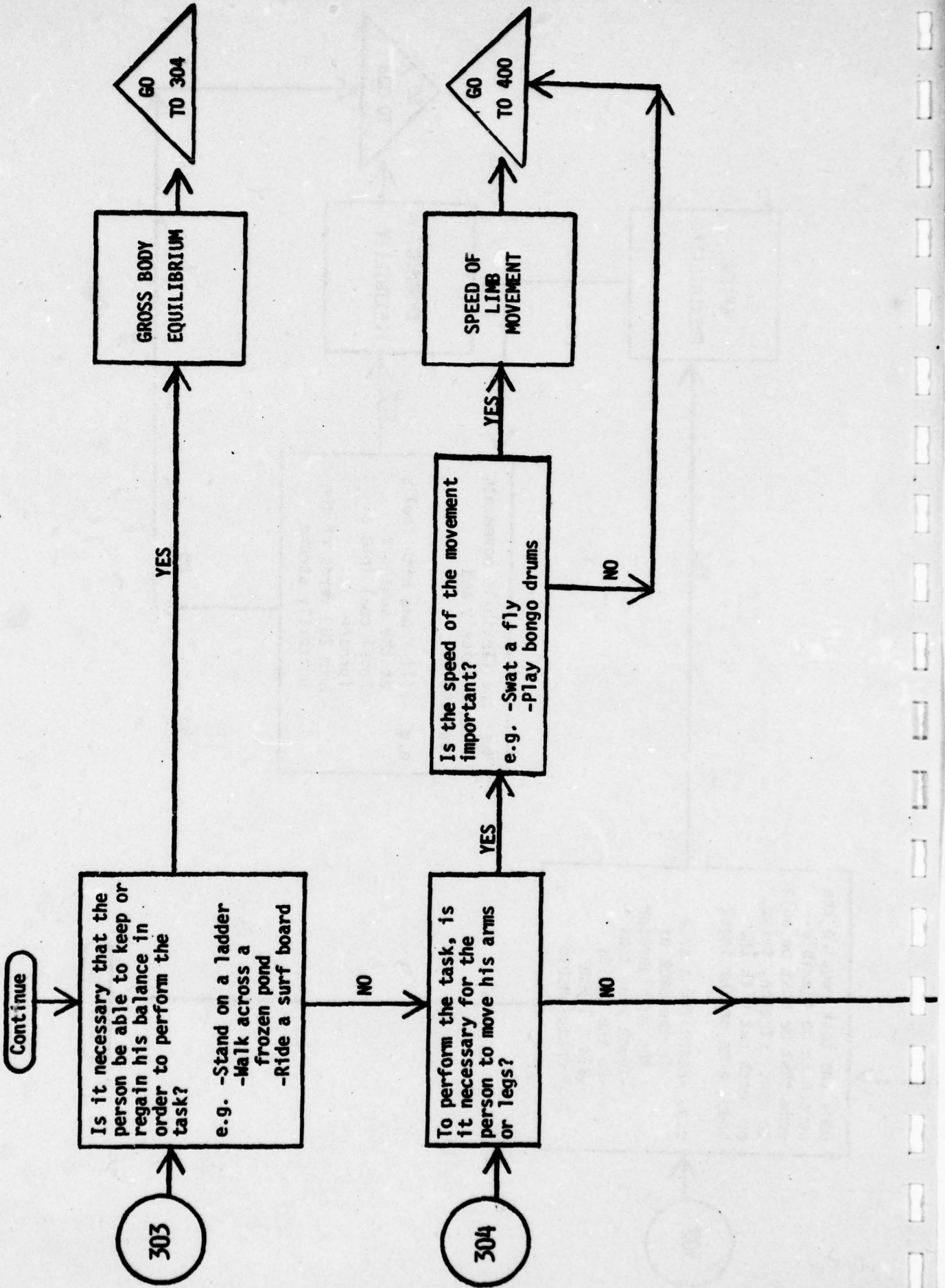

400

Does the task require the whole body to be in motion?

YES

Is it necessary and important to coordinate the movement of arms, legs, and torso together?
e.g. -Move around an obstacle course with no time limit
-Jump rope without tripping
-Perform a skilled ballet dance

YES

GROSS BODY COORDINATION

GO TO 401

NO

Does the task require the movement of 2 or more limbs together in a coordinated action while the body doesn't move because the person is sitting, standing, or lying down?
e.g. -Operate sewing machine with a foot treadle
-Operate forklift truck in a warehouse
-Play drum set in a jazz band

YES

MULTI-LIMB COORDINATION

GO TO 401

NO

Continue

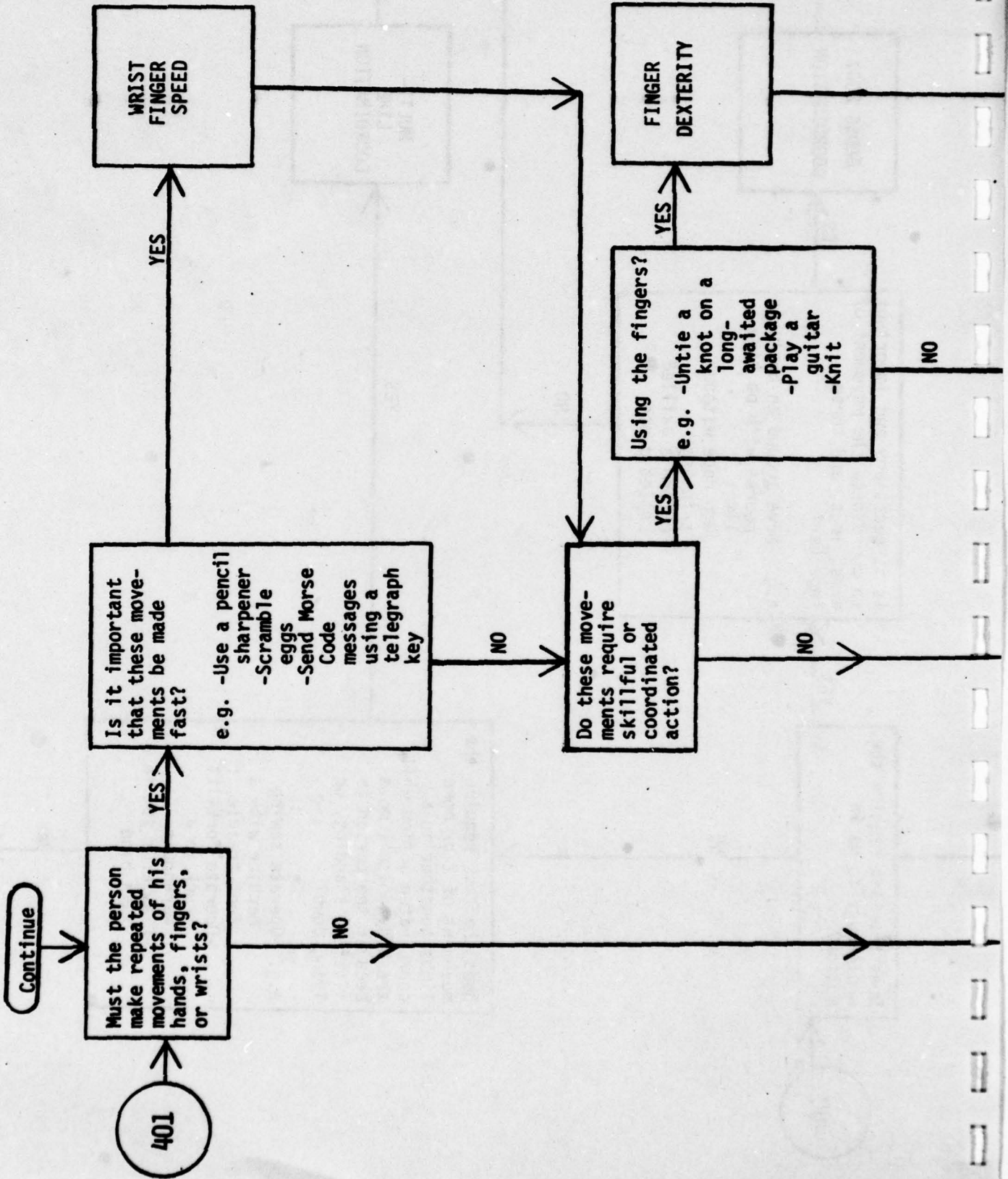

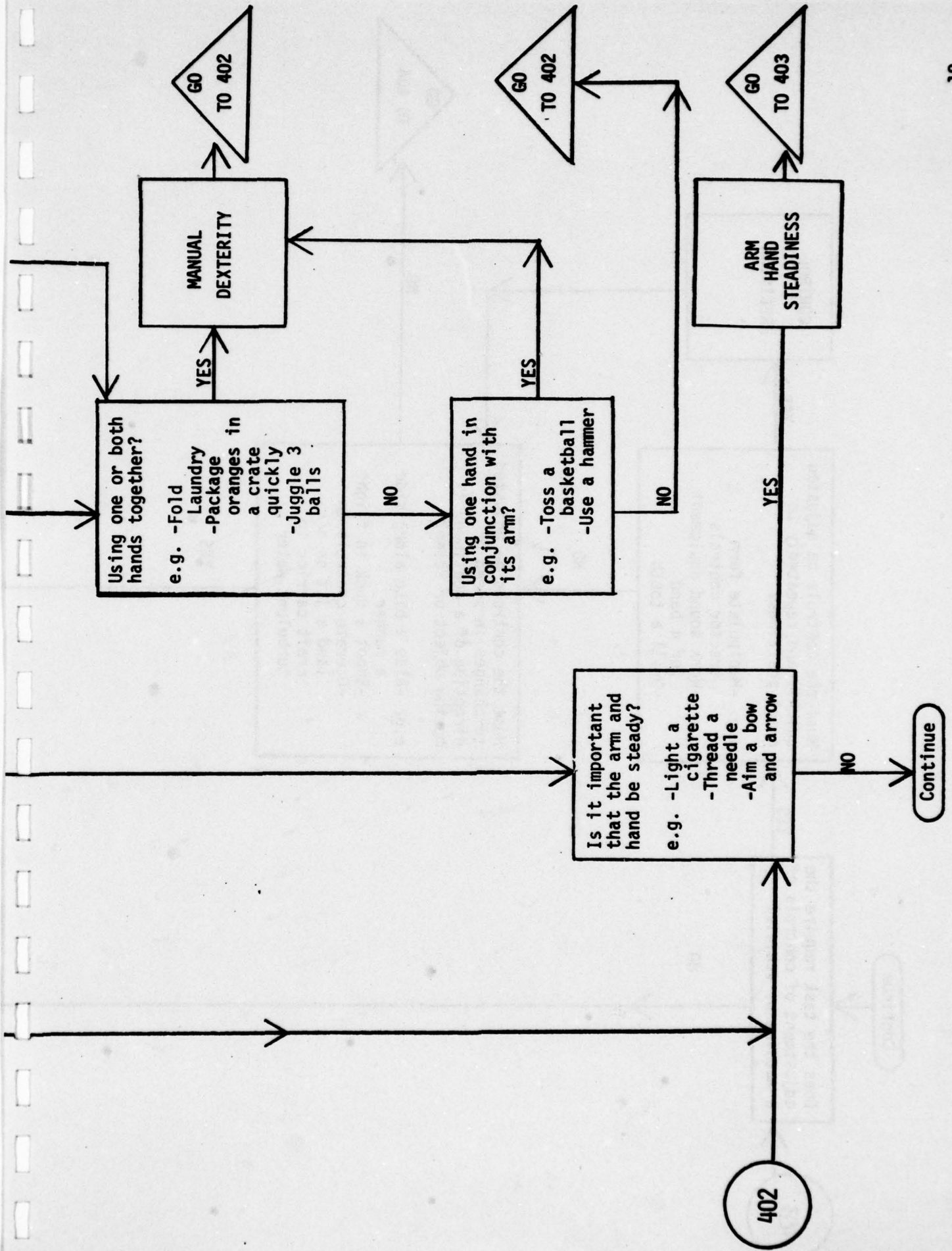

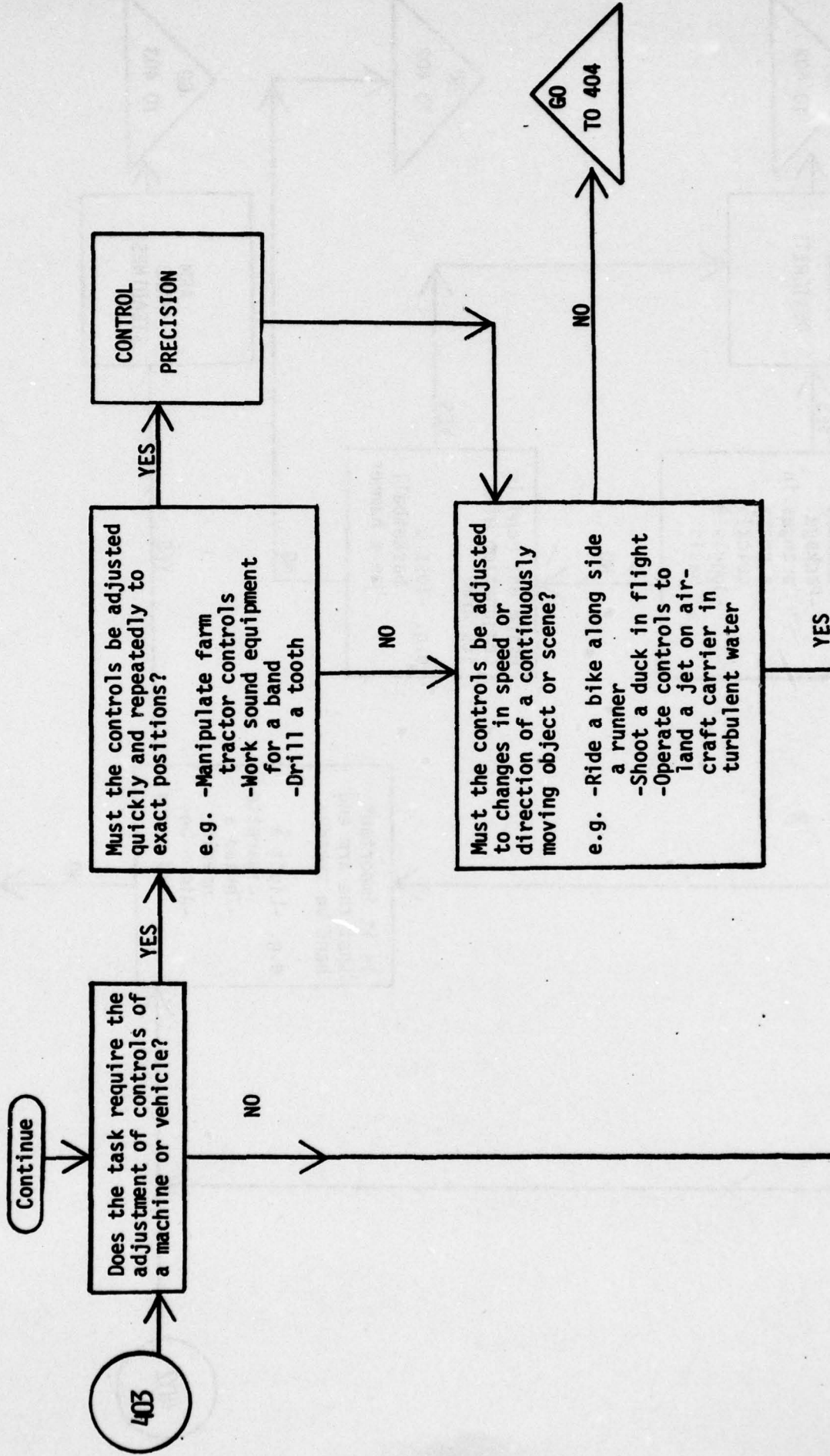

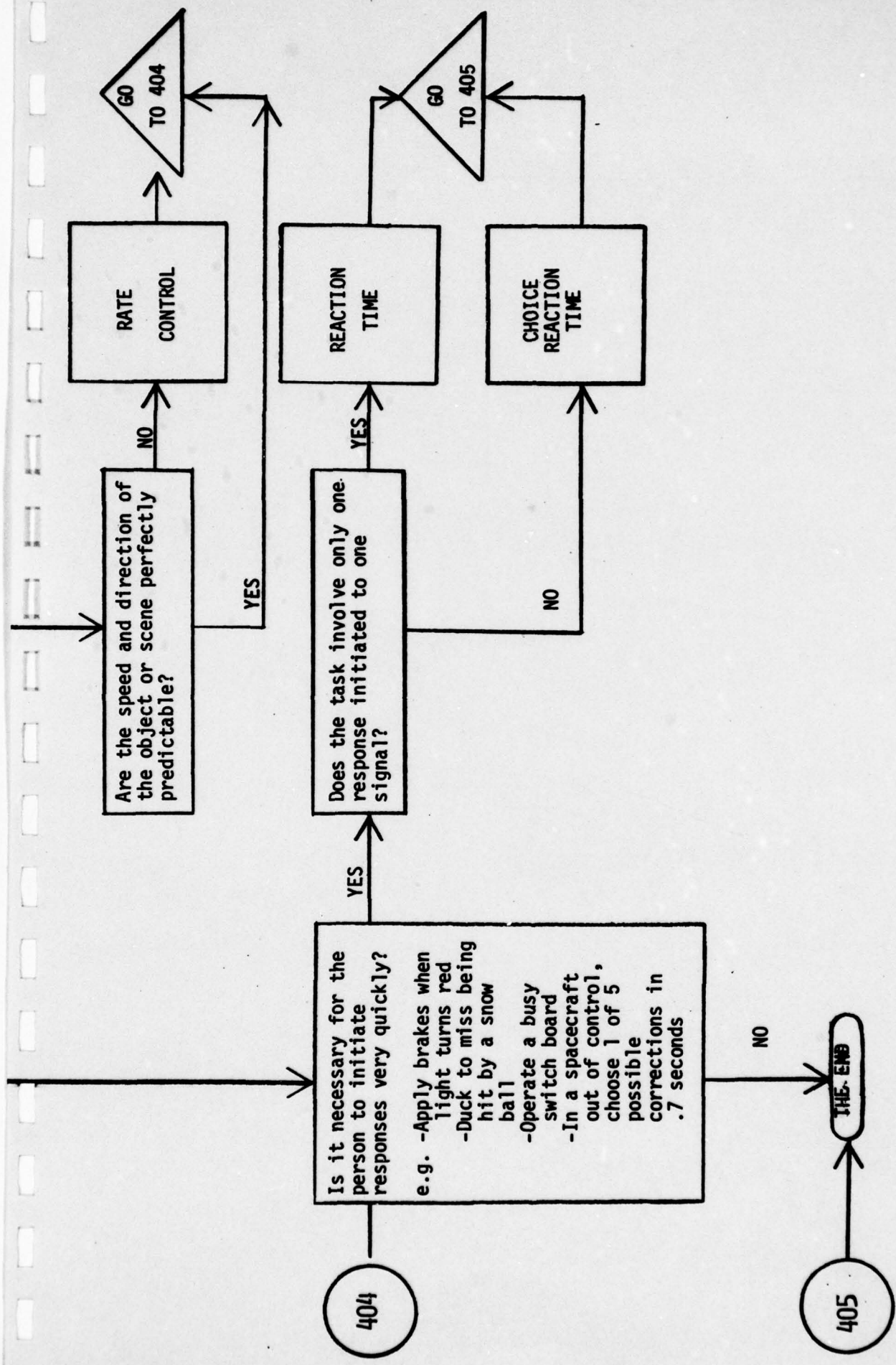



APPENDIX II
INSTRUCTIONS FOR ABILITY ASSESSMENT MANUAL

INSTRUCTIONS

The materials provided to you will be used for the purpose of assessing the ability requirements of jobs. The materials include, detailed descriptions of the tasks required for each job, an Ability Assessment Manual, and an ability profile. Consider the job as it is described and not as you may know it actually to be. Some tasks may, for example, have been left out of the descriptions. Tasks which are not included in the job descriptions should not be considered as part of the job. For those activities which are included, however, you may enhance the information provided by your own personal knowledge.

The first step in analyzing the ability requirements of a job is to very carefully read the job description. Be certain that you fully understand all of the activities in which a worker must engage to complete the job. If possible, you should try to visualize the activities and go through them one by one.

You are to rate the job as a whole. If an ability is necessary for one aspect or part of the job but not for another part of the job--the ability is still needed for the job. You should make all of your decisions with respect to the entire job description.

When you are sure that you understand the job description, you are ready to analyze the job. Open your Assessment Manual to the START box on the top of page 1. The manual requires a series of YES/NO decisions. The basic procedure is to follow the arrows from one box to another. The large boxes are Decision boxes. Decision boxes always contain a question that can be answered with a YES or NO. You must relate each question to the job description to decide on an answer. The YES or NO answer then determines the next arrow to follow. The direction of YES and NO arrows is not consistent (e.g., not all YES arrows go to the right) so after answering the question be sure to follow the arrow which corresponds to your answer.

This procedure of answering the questions in the decision boxes and following the appropriate arrows will eventually lead to Ability boxes. Ability boxes are the square boxes containing the capitalized titles of abilities. When your path takes you to an Ability box you have determined an ability which is required by the job. You should circle the name of that ability on your ability profile, and then continue with the diagram at that Ability box.

Besides Decision and Ability boxes, you will also encounter connectors--Go To Triangles and Number Circles. Go To Triangles send you to Number Circles elsewhere in the manual. Upon reaching a triangle read the number named in the triangle, locate the appropriate Number Circle and then continue following the diagram from that point. Sometimes you may have to turn the page to find the Number Circle. Another connector is the Continue Statement which tells you to turn the page to reveal the next Continue Statement. Note that there is only one arrow leaving Ability boxes, Number Circles and Continue Statements which directs your path through the manual.

Remember that each question in a Decision box must be answered with respect to the job description. Some Decision boxes provide examples to help specify the exact meaning of the question. When answering YES or NO to most of the decision boxes, you must decide whether the specified activities or circumstances are necessary for the successful performance of the job. If you can imagine the job being competently performed without these activities, then they are not essential for the job and you should answer appropriately.

You should make your YES/NO decision based only on the information in the Decision box and the job description, not on past or future Decision boxes or the name of the ability. It is possible that you have encountered this name in a different context where it had a different meaning. The ability name is just for convenience, it is the other information that defines the abilities.

By correctly following the arrows and connectors, you will be able to reach the END box of the diagram. Remember to circle the abilities on your answer sheet that correspond to the Ability boxes that you reach. Do not circle any abilities that you do not encounter. Upon reaching the END box of the diagram you have completed the job analysis.

ABILITY PROFILE

Circle names of required abilities.

Abilities

Oral Comprehension
Written Comprehension
Oral Expression
Written Expression
Memorization
Problem Sensitivity
Originality
Inductive Reasoning
Category Flexibility
Deductive Reasoning
Information Ordering
Mathematical Reasoning
Number Facility
Fluency of Ideas
Time Sharing
Flexibility of Closure
Speed of Closure
Selective Attention
Perceptual Speed
Spatial Orientation

Abilities

Visualization
Static Strength
Explosive Strength
Dynamic Strength
Trunk Strength
Stamina
Extent Flexibility
Dynamic Flexibility
Gross Body Equilibrium
Speed of Limb Movement
Gross Body Coordination
Multilimb Coordination
Wrist Finger Speed
Finger Dexterity
Manual Dexterity
Arm-Hand Steadiness
Control Precision
Rate Control
Reaction Time
Choice Reaction Time

APPENDIX III
TASK DESCRIPTIONS

BASKETBALL

Bill, a 21 year old senior, plays basketball for Artichoke University. He is team captain and since he is the tallest man on the team, plays the center position. During the last game he scored 34 points and rebounded 17 shots. Parts of the game went as follows: On the opening jump, Bill tapped the ball to one of his teammates, they ran down the court and Bill was fouled in the process of shooting. Bill made both of his foul shots. The other team took the ball out of bounds and passed back and forth to each other looking for a good shot. Bill anticipated one of the passes and lunged for the ball which he knocked out of bounds. After the other team scored, there was a fast break and Bill dribbled the length of the court. He faked two opponents and went in for the lay-up. There were very few fouls in the first quarter and the players were running constantly.

DRIVING

A 21 year old female student is going to drive a 1968 Chevrolet Impala during rush hour traffic (approximately 5:30). The trip will begin at the University of Maryland and will end at the Hecht Co. in Silver Spring. This car that she will be driving has a manual transmission (4 speed stick shift) and power steering but no power brakes.

She unlocks her car, gets in and turns the ignition on. Before backing up she fastens her seat belt and turns the radio on. She backs out of her parking space in Lot 1 and makes a right turn onto University Blvd. Next, she makes a right turn onto the approach to Route 1 and proceeds toward the Capital Beltway. Frequent stops and starts are made on the way to the Beltway because traffic is heavy. Upon arriving at the Beltway, she must quickly pull out from the ramp to get into the main traffic stream.

She is driving in the right hand lane at 50 mph and notices an accident up ahead, so she must quickly pull into the center lane. The rest of the driving on the Beltway is marred by two quick panic stops.

She gets off at Georgia Avenue and continues south toward Silver Spring. She is traveling at 30 mph in light to medium traffic with occasional stops and starts for traffic lights.

After arriving at the Hecht Co., she finds an empty parking space between two parked cars and must park parallel.

SIGNAL IDENTIFICATION

The task is an auditory signal identification task. The person is situated in a listening booth and is required to classify different sounds into one of four categories. Each signal depicts engine sounds from a certain type of ship and these signals vary in their level of pitch. The task requires that the signals be classified into one of four pitch categories.

Although the signals within the four categories differ systematically in terms of pitch, the individual signals differ on more than the dimension of pitch. For example, the signals consist of a variety of whines, buzzes, rumbles and roars, some of which are pulsed while others are either rhythmic or continuous. There is considerable overlap between categories with respect to these other dimensions.

The task begins with a training phase. The classification system is explained and two sounds from each category are played. Types of cues are suggested that might be useful in distinguishing one category from another. Then 36 signals are played one at a time, after the signal's category is given, allowing ample opportunity for the refinement of methods of classification.

Upon completion of the training phase the auditory signal identification task begins. An answer sheet is provided giving the four category choices for each signal heard. The required response is to circle the letter that indicates the category chosen.

Each of the signals is heard for either 3, 6, or 9 seconds and is presented in background noise that is either softer, equal to, or louder than the signals themselves. The signals are evenly spaced with a 5 second interval between signals, and the person knows in advance the signal length and background noise level.

ELECTRONIC TROUBLESHOOTING

The task is a simulation of electronic troubleshooting. The requirement is to locate broken wires in electronic devices. The basic format of a problem is a current-flow diagram (shown below).

The current-flow diagrams are line drawings of electrical circuits showing numbered buttons, electrical pathways, logic gates and lights. A logic gate is a device which current may enter and flow through depending upon certain conditions. An AND logic gate requires that current must be flowing through all of the pathways entering the gate before it allows the current to pass through the other side. An OR logic gate only needs current on one of the pathways entering the gate before the current can pass through to the other side. The state of the output at any point in a current-flow diagram is determined by the preceding logic gates. Examples of two simple circuits are shown below.

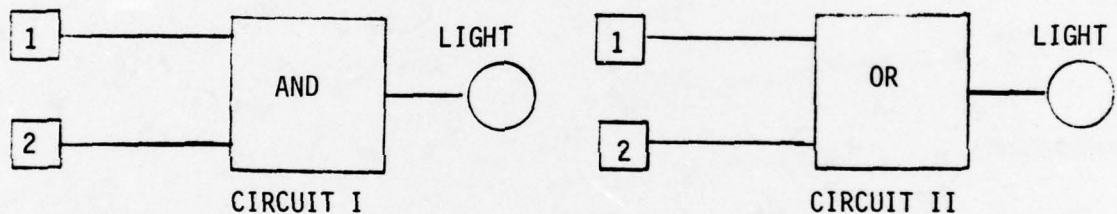

In circuit I, the light will not go on unless switches 1 and 2 are both depressed, allowing current to flow through the AND logic gate. In circuit II, the light will light if either switch 1 or switch 2 (or both) is depressed, since only one switch is necessary to permit current through the OR logic gate. Each fault-finding problem is constructed with a number of such AND and OR gates in the circuit.

In each circuit a single faulty wire, or "breakpoint," may be present. At such a point the current flow is disrupted. The task is to identify the location of this break. An example of a circuit with a potential breakpoint is shown below. A breakpoint may occur at either point A or point B.

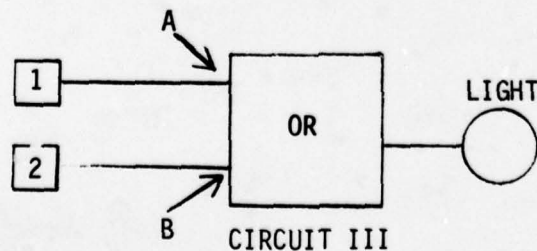

Assume that the breakpoint occurs at point B. If switch 1 is depressed and the light goes on, it is known that a break cannot exist at point A. If switch 2 is depressed and the light fails to go on, point B must be faulty. In the task problems (paper-and-pencil representations of the circuits), the opportunity exists to place a hypothetical "light bulb" at various designated points ("sockets") in the circuit diagram in order to find which of the possible breakpoints is, in fact, faulty. Each problem contains exactly one true breakpoint which has to be identified from among several potential breakpoints. In circuit III above, only one test is actually necessary to locate the breakpoint, since if A is not faulty, B must be, and vice versa.

In order to locate the breakpoint, the circuit must be tested by placing light bulbs in appropriate sockets and by depressing buttons. Feedback is provided through a set of display lights as to the outcome of the test. If the circuit is complete and the hypothetical light bulb lights, a green light flashes. If the hypothetical light does not light, meaning there is a breakpoint in the circuit, a red display light flashes. If an erroneous test is made (i.e., there is no pathway between the buttons "pushed" and the "socket" selected) a yellow display light flashes. Tests on the circuit are made one at a time, until the location of the breakpoint is determined. If the incorrect breakpoint was chosen, testing may be continued.

The task requires that work be performed as fast as possible and efficiently (i.e., gain as much information as possible on each test). The person is instructed not to make any notations on the current-flow diagrams about previous tests that have been made.

The following diagram shows an average task problem. The numbered boxes are the buttons which put current through the lines, the numbered stars are possible breakpoints and the lettered circles are sockets. The problems vary in difficulty with respect to the number of buttons and logic gates employed. The problems also differ in perceptual complexity with respect to the spatial layout of the diagrams.

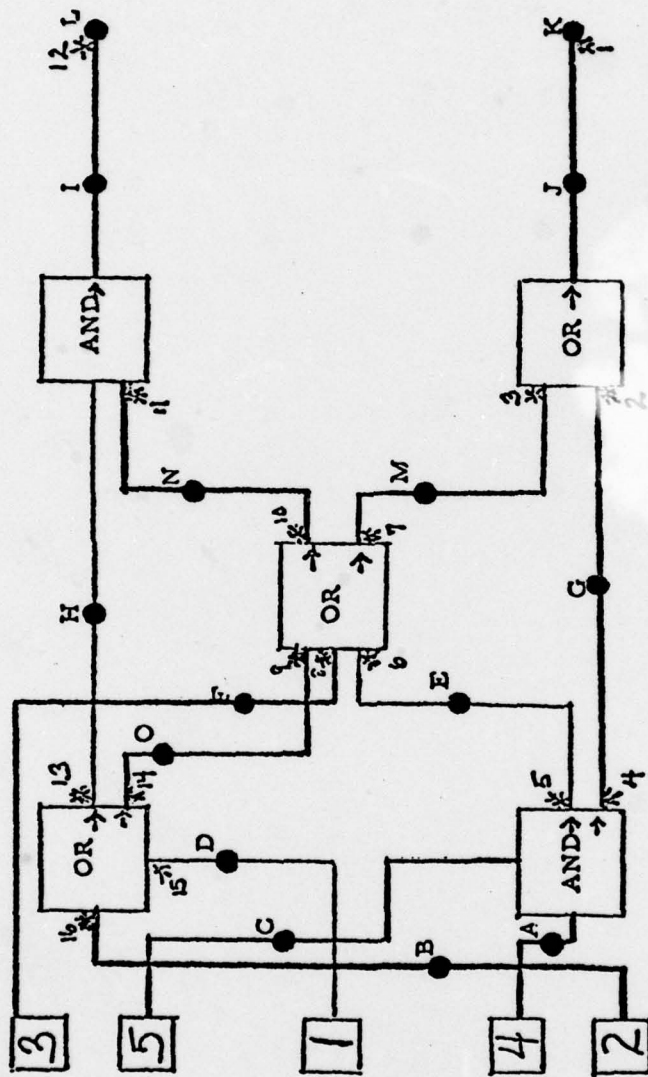

SONAR

The task is a simulation of a submarine sonar operation. The person is equipped with a set of headphones and his job is to monitor information coming through the headphones, detecting auditory signals and labeling them.

The auditory signals consist of a set of short tones (each about one second in duration) which vary in pitch and loudness. The pitch of a signal is determined by the target that is picked up by sonar. One must listen closely to differentiate tones since some are very similar in pitch. The loudness is determined by the distance of the target--the closer the target the louder the signal.

There are 15 possible targets, each associated with a different pitched tone. (The person always has a list of the target names in front of him.) Prior to the beginning of the task, the person is familiarized with the signals (tones) and their respective targets by listening to a practice tape. On the practice tape, each target is named and then is followed by its signal. After hearing each target name paired with its signal three times, the person is given practice without the target names. A signal is played and the person responds by writing the target it represents on an answer sheet. All signals are played at a comfortable level that is easily heard. The person receives immediate feedback as to the correct target.

The sonar task lasts approximately three hours during which the person listens for signals occurring infrequently and spaced randomly. (Only 60 signals actually occur during the three hours and the time between signals ranges from 15 seconds to 15 minutes.) Upon detecting a signal, the person immediately presses a button signifying that an observation was made and then writes down the name of the target he thinks was picked up. Since the targets may be picked up at various distances, the loudness of the tones varies greatly making signals for targets which are very far away practically inaudible. The person must therefore listen carefully not only to detect signals from distant targets but also to differentiate between signals of very similar pitch. The person is scored on whether a signal actually occurred within the two second period prior to a button press, and if a signal present was detected, whether the target was correctly identified.

APPENDIX IV
JOB DESCRIPTIONS

OS: Operations Specialist

RADAR NAVIGATION

1. Plot ship's position on charts
2. Make course/speed recommendations to bridge
3. Make course change time recommendations to bridge
4. Make drop anchor recommendations to bridge
5. Compute set/drift
6. Inform bridge of navigation hazards
7. Figure course made good
8. Record ranges, depths in navigation log
9. Evaluate surface contacts in entering/leaving port
10. Figure turn time
11. Plot approach to anchorage
12. Provide mark times
13. Obtain ranges from fixed points
14. Obtain fathometer fixes
15. Obtain visual fixes
16. Compute anchor drop distance
17. Obtain Omega navigation data
18. Obtain LORAN lines of position
19. Compute speed made good
20. Compute advance and transfer
21. Plot danger bearings

SURFACE

1. Report closest point of approach (CPA), time of CPA
2. Report course/speed on surface contacts
3. Maintain radar contact log
4. Compute station taking solution on maneuvering board
5. Maintain surface search area
6. Compute desired wind on maneuvering board
7. Ensure scope ranges are correct
8. Encode/decode signals/messages using NUCO/couple
9. Lay out ship's course
10. Maintain surface sub-surface coordination (SSSC) log
11. Use plotting symbols
12. Authenticate on R/T circuits
13. Set up X, Y grid (cartesian)
14. Set up geographic (geo ref) grid
15. Plot hot areas
16. Plot land areas
17. Plot mine fields
18. Maintain surface summary status board
19. Compute true wind in maneuvering board
20. Maintain surface track of ships on DRT/NC2
21. Maintain DRT/NC-2 log

SURFACE (Continued)

22. Enter latitude/longitude settings into DRT
23. Report weather/jamming detected on radar
24. Figure course to avoid
25. Figure torpedo problems on maneuvering board
26. Figure point romeo (nuclear blast)
27. Plot formation diagram
28. Set scales of DRT
29. Operate link 14 circuit
30. Plot/track hurricanes/typhoons
31. Report contacts to bridge
32. Provide helo approach information

ASW

1. Plot weapon release point
2. Plot weapon impact area
3. Control ASW aircraft (fixed wing)
4. Control ASW aircraft (rotary wing)
5. Plot sonobuoy patterns
6. Control planting of sonobuoys
7. Pass sub contact information on R/T circuits using scramble tables/signal book
8. Coordinate with other ships in ASW attack phase
9. Plot torpedo danger area
10. Construct torpedo danger area
11. Construct furthest on circle (FOC)
12. Extract zig zag plan from publications
13. Recommend actions for zig zag plan to bridge
14. Recommend torpedo evasive actions to bridge
15. Recommend ASW search plans to bridge
16. Compute jump distance
17. Compute transition point
18. Recommend course/speed to maintain ASW search pattern to bridge

AAW

1. Maintain altitude separation of aircraft.
2. Convert ground speed to indicated air speed
3. Control combat air patrol (CAP) aircraft
4. Provide flight follow information
5. Identify air contacts by IFF scope response
6. Identify air contacts using CAP
7. Establish air contact priorities
8. Coordinate friendly/bogy aircraft with other units in AAW mode
9. Pilot air safety corridors
10. Report air contacts using snip net procedures
11. Report air contacts using fan net procedures
12. Maintain air contact log

AAW (Continued)

13. Maintain air intercept log
14. Figure course/speed of air contacts on vertical plot
15. Make progress of air intercept report on R/T nets
16. Relay pilot weather reports on R/T nets

AMPHIBIOUS

1. Plot amphibious (amphib) assault waves
2. Provide course/speed corrections to amphib assault waves
3. Position line of departure (LOD) craft (radar)
4. Reassign craft from LOD
5. Record range/bearing of amphib assault waves
6. Vector causeways into position
7. Control support helicopters (amphib)
8. Lay out assault lanes/corridors/swept channels

SEARCH AND RESCUE

1. Figure scouting problems
2. Plot man overboard
3. Obtain range/bearing of distress signals (directional finding, radio)
4. Set up search and rescue (SAR) search patterns
5. Make turn recommendations to bridge (man overboard)
6. Make emergency signal recommendations to bridge (man overboard)
7. Compute wind/current drift on life rafts/personnel in water
8. Compute life expectancy of man overboard
9. Vector recovery craft to recovery pick up point
10. Identify aircraft in distress by analyzing flight patterns

GUN FIRE SUPPORT

1. Plot gun fire targets
2. Plot friendly front lines/no fire zones/free fire zones
3. Inspect charts for intervening heights
4. Set up gun fire support triangle
5. Lay out dead reckoning (DR) estimated position (EP) track
6. Maintain gun fire support navigation log
7. Record spotter information in R/T log
8. Lay out gun target lines
9. Plot ground observer/command post position
10. Convert grid positions into ranges/bearings
11. Plot counter-battery targets

GUN FIRE SUPPORT (Continued)

12. Convert true bearing to relative bearings
13. Estimate spot corrections from radar scope
14. Convert spotter grid correction to a corrective spot

EQUIPMENT OPERATION

1. Light off/secure radars
2. Tune radars
3. Light off/adjust/secure radar repeaters
4. Set frequencies into preset channels (such as URD-4, SRC 20)
5. Enter keyset entries (navigation, communication, ESM) into NTDS computer
6. Identify emergency situations by IFF
7. Enter operating modes into radar consoles
8. Update ship IFF ID code

PLOTTING

1. Figure CPA/time of CPA on maneuvering board
2. Figure CPA/time of CPA on radar scope
3. Figure CPA time of CPA on DRT/NC2
4. Figure course/speed on maneuvering board
5. Figure course/speed on DPT/NC2
6. Figure course/speed on radar scope
7. Track contacts on DRT/NC2
8. Maintain plots
9. Maintain status boards (rate related)
10. Keep running tracks on contacts
11. Plot NTDS contacts (manually)
12. Plot electronic support measures (ESM) contact (racket) information
13. Use casualty plotting procedures on DRT/NC2 (Halifax plot)
14. Compute deviation on old charts
15. Compute latitude and longitude from grid posits (without using template)
16. Compute target position by bearings only (without using template)
17. Compute target course and speed by bearings only

MR: Machinery Repairman

TECHNICAL DRAWINGS

1. Construct Geometric Forms
2. Draw sketches from mechanical drawings and parts

FABRICATION AND MANUFACTURING

1. Perform drilling, reaming, spotfacing, countersinking, and tapping using a bench or pedestal drill
2. Compute drill and machine reamer feeds and speeds
3. Operate pedestal grinders
4. Determine types and classes of press and running fits
5. Determine classes of thread fits
6. Compute decimal equivalent from fraction
7. Compute english and metric systems of measure
8. Solve basic algebraic problems
9. Solve basic ship trigonometric layout problems
10. Solve ratio and proportion problems
11. Perform the following operations using an engine lathe:
 - a. straight turning, facing, and knurling between centers using chuck
 - b. cut internal and external single lead right and left hand A.N.S., acme, and square threads
 - c. turn tapers, using compound rest
 - d. turn tapers, using taper attachment
 - e. use grooving and parting tools
 - f. mount work on face plate
 - g. place work in four jaw chuck, using dial indicator
 - h. drill, ream, bore, and tap
 - i. thread to bottom of a hole or shoulder
 - j. perform common weekly adjustments to lathe
 - k. eliminate taper using tailstock
12. Compute feeds and speeds for lathe operation
13. Compute thread dimensions for A.N.S., acme, and square threads
14. Compute taper per foot/per inch
15. Repair damaged threads using single point tool
16. Determine proper angles and grind lathe cutting and threading tools from high speed steel
17. Perform the following operations using a planer or shaper:
 - a. plane or shape flat surfaces
 - b. plane or shape grooves and slots
 - c. compute feeds and speeds for shaper and planer cutting tools
18. Determine proper angles and grind shaper and planer cutting tools
19. Perform the following operations using a mill:
 - a. slab milling
 - b. straddle milling
 - c. slotting
 - d. end milling

FABRICATION AND MANUFACTURING - (Continued)

20. Compute, set up and cut a spur gear
21. Compute feeds and speeds for milling machines
22. Perform the following indexing operations using dividing head:
 - a. plain
 - b. rapid
 - c. angular
23. Manufacture nameplates from various materials by engraving with the pantograph
24. Perform angular and disk metal bandsaw cutting
25. Perform finish machining operations in accordance with finish symbols
26. Operate arbor and hydraulic presses
27. Cut external and internal threads
28. Manufacture by filing, radii, flats, and holes
29. Ream holes using hand reams
30. Repair damaged internal and external threads using taps, dies, die nuts, thread combs, and/or files
31. Select lubricants for threading, reaming, and drilling operations
32. Select band saw blades determined by type and thickness of material
33. Select fastening devices
34. Perform file hardness tests
35. Select lapping compounds and perform hand lapping operations
36. Manufacture parts from mechanical drawings and sketchings
37. Remove broken studs by drilling, tapping and extracting
38. Remove broken taps with tap extractors
39. Perform circular engraving by use of index and radius plates
40. Use oxyacetylene equipment
41. Perform machining of plastics

MAINTENANCE PLANNING AND QUALITY ASSURANCE

1. Use maintenance requirement cards (MRC)
2. Complete maintenance data forms for:
 - a. completed maintenance actions (MAF)
 - b. deferred maintenance actions
 - c. work requests

LOGISTICS SUPPORT

1. Operate and maintain a tool issue room
2. Identify categories of material contained in each volume of coordinated shipboard allowance list (COSAL)

ET: Electronics Technician

TROUBLESHOOTING

1. Identify standard electronic/mechanical symbols as used on schematics, logic diagrams, flow charts, etc.
2. Make point-to-point resistance checks to isolate faulty components
3. Make point-to-point voltage checks to isolate faulty components
4. Check stage/component input/output signals with oscilloscope
5. Research technical publications for troubleshooting/maintenance information
6. Use schematics/logic diagrams in fault isolation procedures
7. Use troubleshooting charts/tables in fault isolation procedures
8. Troubleshoot faulty equipment by comparing parameters with operational equipment
9. Troubleshoot equipment by substituting known good parts
10. Troubleshoot equipment by signal injection method
11. Trace cables to locate shorts/opens
12. Verify ship's gyro inputs to equipment
13. Analyze equipment front panel indications for fault isolation
14. Train operators to perform routine operational tests on electronic equipments
15. Clean/lubricate general electronic equipments (drawer slides, small mechanical drives, etc.)
16. Remove/replace cables/transmission lines
17. Install special projects alterations on assigned equipment
18. Perform operational test of equipment upon completion of alteration or overhaul
19. Perform preventive maintenance management program (PMMP) procedures on assigned equipment
20. Test/check electrical/electronic components to determine capability to repair
21. Adjust automatic frequency control (AFC) circuits
22. Adjust mechanical linkages
23. Adjust gear trains
24. Remove/replace cathode ray tubes
25. Pre-set frequencies on multichannel equipment (channelize)
26. Adjust micro switches
27. Pressure check systems/components
28. Analyze circuits using qualitative and quantitative analysis

GENERAL MAINTENANCE

1. Measure RF power output
2. Tune klystrons
3. Align receiver for maximum sensitivity
4. Adjust low voltage power supplies
5. Adjust high voltage power supplies
6. Adjust oscillators
7. Adjust transmitter frequency
8. Adjust pulse repetition frequency (PRF)
9. Remove/replace individual electronic components (such as switches, resistors, capacitors)
10. Clean electric/electronic equipment with solvent
11. Mathematically compute XL and XC
12. Mathematically compute total circuit resistance
13. Mathematically compute frequency
14. Build-up/fabricate coaxial cables
15. Visually inspect equipment for defects (such as loose wires, burned components)
16. Clean relay/switch contacts
17. Make wiring changes in distribution main frame (such as new circuits, rerouting circuits)
18. Assemble cables/test leads (install connectors, probes, etc.)
19. Install field changes in electronic equipment
20. Install modifications in electronic equipment IAW electronics information bulletins (EIB's)
21. Inspect waveguides

TEST EQUIPMENT MAINTENANCE

1. Troubleshoot test equipment to failed circuit part
2. Remove/replace components of test equipment
3. Adjust/align test equipment
4. Clean/lubricate test equipment
5. Test/inspect test equipment

AIR TRAFFIC CONTROLLER

Controls air traffic on and within vicinity of airport according to established procedures and policies to prevent collisions and to minimize delays arising from traffic congestion. Answers radio calls from arriving and departing aircraft and issues such landing and takeoff instructions and information such as: runway to use, wind velocity and direction, visibility, taxiing instructions and pertinent data on other aircraft operating in vicinity. Transfers control of departing flights to air traffic control center and accepts control of arriving flights from air traffic control center, using telephone or interphone. Alerts airport emergency crew and other designated personnel by radio or telephone when airplanes are having flight difficulties. Pushes buttons or switches to control airport floodlights and boundary, runway, and hazard lights. Scans control panel to ascertain that lights are functioning. Operates radio and monitors radarscope to control aircraft operating in vicinity of airport. Receives cross-country flight plans and transmits them to air traffic control center. Signals aircraft flying under visual flight rules, using electric signal light or flags. Controls cross-runway traffic by radio directions to guards or maintenance vehicles. Keeps written record of messages received from aircraft. Controls traffic within designated sector of airspace between centers and beyond airport control tower area.

79