

AD-A066 680

FOREIGN TECHNOLOGY DIV WRIGHT-PATTERSON AFB OHIO
TRANSACTIONS OF THE 2ND ALL UNION CONFERENCE ON CHARGED PARTICL--ETC(U)
JAN 79

F/6 20/7

UNCLASSIFIED

FTD-ID(RS)T-2212-78

NL

| OF |
AD
A066680



END
DATE
FILMED
5 -79
DDC

①

APA066680

FOREIGN TECHNOLOGY DIVISION



TRANSACTIONS OF THE 2nd ALL UNION CONFERENCE ON
CHARGED PARTICLE ACCELERATORS
(Selected Articles)



Approved for public release;
distribution unlimited.

79 03 12 254

EDITED TRANSLATION

FTD-ID(RS)T-2212-78

12 January 1979

MICROFICHE NR: *AD-79-C-000104*

Transactions of the 2nd All Union Conference on
Charged Particle Accelerators (Selected Articles)

English pages: 26

Source: Trudy Vtorogo Vsesoyuznogo Soveshchaniya
po Uskoritelyam Zaryazhennykh Chastits,
Moscow, 11-18 November 1970, Vol. 1,
1972, pp. 95-103

Country of origin: USSR

Translated by: Robert D. Hill

Requester: FTD/TQTD

Approved for public release; distribution unlimited

ACCESSION for	
NTIS	Waive Section <input checked="" type="checkbox"/>
DOC	BIT Section <input type="checkbox"/>
UNANNOUNCED	<input type="checkbox"/>
JUSTIFICATION	
BY	
DISTRIBUTION/AVAILABILITY CODES	
Dist.	AVAIL. and/or SPECIAL
<i>A</i>	

THIS TRANSLATION IS A RENDITION OF THE ORIGINAL FOREIGN TEXT WITHOUT ANY ANALYTICAL OR EDITORIAL COMMENT. STATEMENTS OR THEORIES ADVOCATED OR IMPLIED ARE THOSE OF THE SOURCE AND DO NOT NECESSARILY REFLECT THE POSITION OR OPINION OF THE FOREIGN TECHNOLOGY DIVISION.

PREPARED BY:

TRANSLATION DIVISION
FOREIGN TECHNOLOGY DIVISION
WP-AFB, OHIO.

Table of Contents

U.S. Board on Geographic Names Transliteration System.....	ii
A Direct-Action, Heavy-Current Electron Pulsed Accelerator, by L.N. Kazanskiy, A.A. Kolomenskiy, et al.....	1
26. A High-Power Nanosecond Generator, by L.N. Kazanskiy, B.N. Yablokov.....	10
27. Research of Intense Electron Beams on the Rius-5 Accelerator, by Ye.A. Abramyan, S.B. Vasserman, et al.....	18

U. S. BOARD ON GEOGRAPHIC NAMES TRANSLITERATION SYSTEM

Block	Italic	Transliteration	Block	Italic	Transliteration
А а	А а	A, a	Р р	Р р	R, r
Б б	Б б	B, b	С с	С с	S, s
В в	В в	V, v	Т т	Т т	T, t
Г г	Г г	G, g	У у	У у	U, u
Д д	Д д	D, d	Ф ф	Ф ф	F, f
Е е	Е е	Ye, ye; E, e*	Х х	Х х	Kh, kh
Ж ж	Ж ж	Zh, zh	Ц ц	Ц ц	Ts, ts
З э	З э	Z, z	Ч ч	Ч ч	Ch, ch
И и	И и	I, i	Ш ш	Ш ш	Sh, sh
Й й	Й й	Y, y	Щ щ	Щ щ	Shch, shch
К к	К к	K, k	Ъ ъ	Ъ ъ	"
Л л	Л л	L, l	Ы ы	Ы ы	Y, y
М м	М м	M, m	Ь ь	Ь ь	'
Н н	Н н	N, n	Э э	Э э	E, e
О о	О о	O, o	Ю ю	Ю ю	Yu, yu
П п	П п	P, p	Я я	Я я	Ya, ya

*ye initially, after vowels, and after ъ, ь; e elsewhere.
When written as ě in Russian, transliterate as yě or ě.

RUSSIAN AND ENGLISH TRIGONOMETRIC FUNCTIONS

Russian	English	Russian	English	Russian	English
sin	sin	sh	sinh	arc sh	sinh ⁻¹
cos	cos	ch	cosh	arc ch	cosh ⁻¹
tg	tan	th	tanh	arc th	tanh ⁻¹
ctg	cot	cth	coth	arc cth	coth ⁻¹
sec	sec	sch	sech	arc sch	sech ⁻¹
cosec	csc	csch	csch	arc csch	csch ⁻¹

Russian English

rot curl
lg log

25.

A DIRECT-ACTION, HEAVY-CURRENT ELECTRON PULSED ACCELERATOR
L.N. Kazanskiy, A.A. Kolomenskiy, G.O. Meskhi, B.N. Yablokov
(Physics Institute im. P.N. Lebedev of the Academy of Sciences
of the USSR)

In recent years there has been a rapid development in the new scientific trend connected with the obtaining and use of pulsed electronic beams [1, 2]. They find use in many regions of physics, chemistry, biology, and different applied fields. With the development of the electron heavy-current accelerator at FIAN [Physics Institute im. P.N. Lebedev of the Academy of Sciences, USSR], we had in mind the conducting of investigations on the physics of intense relativistic electron beams in a vacuum and media and also the acceleration of ions due to the collective interaction with the intensive electron beams.

The requirements to the parameters of the electron beam, determined by the planned goals, are not identical, and with the development of the electron heavy-current accelerator (ESU-1) we decided to discuss the mean parameters: energy of the electrons, 2-3 MeV, current, 30-50 kA, pulse duration, $\sim 30-50$ ns. Here almost the complete absence of the experience of the building of similar apparatuses and the extreme deficiency of working areas were taken into account. After a detailed examination of the possible designs of the ESU, we dwelled on the electron heavy-current accelerator with a double shaping line of the coaxial type filled with a dielectric with a high dielectric constant.

The line is charged in a resonance manner by a pulsed voltage oscillator (GIN) for a time of the order of $5 \cdot 10^{-7}$ s and is commutated by a single-gap multispark gap operating in compressed gas. Included at the output of the double shaping line (DFL) is a transforming line (TL) with a coefficient of transformation of ~ 1.5 loaded on an electron gun of the autoemission type (Fig. 1).

The selection as the filler of the line of the dielectric with a large value of ϵ was determined by the following considerations:

1. The power which can be removed from the line

$$P \sim E^2 \sqrt{\epsilon}.$$

Since the maximum permissible field strengths for all liquid dielectrics in our range of duration of the charge are approximately identical and lie in the region of 200-300 kV/cm, the use of dielectrics with a large value of ϵ allows obtaining from the same volume a power several times larger.

2. The use of dielectrics with large ϵ permits sharply reducing the length of the apparatus, which in our case has great value.

3. The use of dielectrics with large ϵ permits using a transforming line of short length and lowering the charged voltage of the DFL.

After a careful study of the high-voltage properties of different dielectrics (water, alcohols, different alcohols of glycerine), we discussed the technical glycerine as having sufficiently good frequency properties in a wide frequency range and providing an admissible shape of the pulse.

The selection of the coaxial design of the DFL was determined by the fact that in contrast to the band design, provided in it is the complete shielding of the fields by a grounded external electrode, the fringe effects in it are substantially less, and the matching of all the elements of the accelerator is easier to carry out. However, the coaxial geometry has a number of shortcomings. The shape of the voltage pulse generated by the DFL has an ideal shape if the wave resistances of both lines are equal.

However, in this case the maximum strengths of the electrical field in the lines prove to be essentially identical

$$\frac{E_{\text{HOP}}}{E_{\text{OH}}} = \frac{R_{\text{OH}}}{R_{\text{OP}}} = \exp\left(-\frac{z\sqrt{\epsilon}}{80}\right),$$

where R_{OH} and R_{OP} are radii of the internal and middle electrodes, and $z = z_{\text{HOP}} - z_{\text{OH}}$ is the wave impedance of the lines.

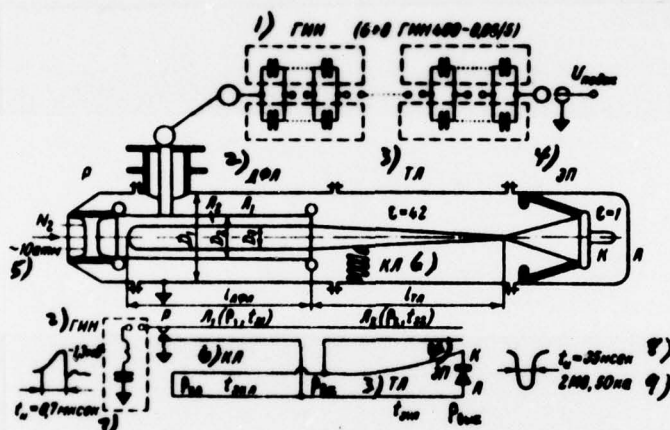

Fig. 1. Schematic diagram of the apparatus ESU. KEY: 1) GIN; 2) DFL; 3) TL; 4) EP; 5) 10 atm; 6) KL; 7) μs ; 8) ns; 9) kA.

At different impedances of the lines, the pulse will be accompanied by a sequence of stray pulses (Fig. 2). The amplitude of these stray pulses with commutation of the internal line is

$$u_n = u \left(\frac{z_{\text{OH}} - z_{\text{HOP}}}{z_{\text{OH}} + z_{\text{HOP}}} \right)^n \quad \text{where } u \text{ is the voltage of the main pulse.}$$

In the case of equal maximum strengths in the lines, the ratio of the wave impedances is

$$z_{\text{OH}}/z_{\text{HOP}} = \exp\left(\frac{u}{E R_{\text{OH}}}\right),$$

where u is the voltage in the line; E - the maximum field strength and R_{OH} - the radius of the internal electrode.

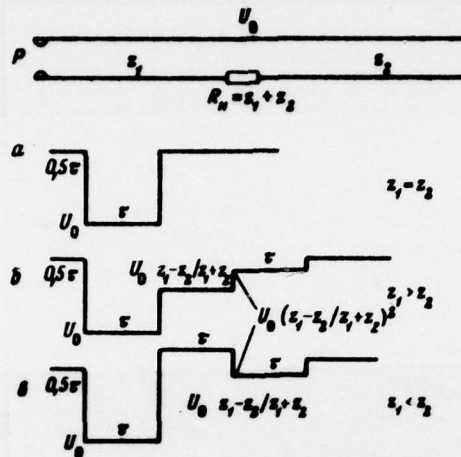

Fig. 2. Shaping of the pulses in a double shaping line at different ratios of wave impedances of its lines.

The case of the equal impedance of the lines and the case of equal strengths limit the region in which it follows to select the geometrical parameters of the double shaping lines (Fig. 3). Parameters of the apparatus ESU-1 and its model ESU-0 (see below) are given in the table. The charge is accomplished in a resonance manner from the pulsed voltage oscillator. The use in the DFL of a polar dielectric with a small specific resistance ρ leads to the need to pay attention to losses in the dielectric in the process of the charge. If we limit the losses of energy by ten percent from the energy stored in the GIN, then the minimum frequency of the charge is $f \geq 4 \cdot 10^{13} / \epsilon \rho$. For glycerine $\epsilon \approx 40$, $\rho \approx 1.5 \cdot 10^8$ ohms/cm and $f_{\text{min.}} = 0.7$ MHz. In our case for the charge of the DFL, it was found convenient to use 6-8 standard GINs of the Serpukhov condenser plant GIN-400-0.06/5 with an impact voltage of 400 kV and impact capacitance of 12 nF connected in two parallel columns each with three-four in series. As the experiments showed, parallel operation of the GINs can be achieved by connecting in parallel each stage of each GIN. In a design sense this is carried out by means of a single column, in which gathered are all the dischargers which operate in an atmosphere of nitrogen at a pressure of 3 atm.

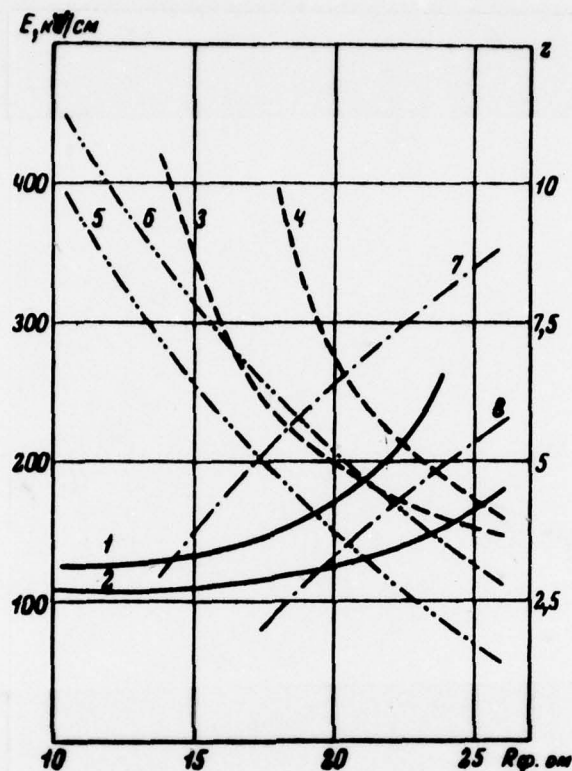

Fig. 3. Field strength in lines and wave impedances as a function of the geometry of the lines. 1 - E_H when $D_1 = 60$ cm; 2 - E_H when $D_1 = 70$ cm; 3 - E_{BH} when $D_3 = 20$ cm; 4 - E_{BH} when $D_3 = 28$ cm; 5 - Z_{HAP} when $D_1 = 60$ cm; 6 - Z_{HAP} when $D_1 = 70$ cm; 7 - when $D_3 = 20$ cm; 8 - Z_{BH} when $D_3 = 28$ cm.

For the experimental checking of the principles assumed as a basis of the accelerator ESU-1, a small apparatus, model ESU-0, with an energy of 600-800 keV (Fig. 1) was built. The external line is commutated by means of a spark gap filled with nitrogen at a pressure of 4-7 atm. Checked on this apparatus are the different types of dischargers (axial and radial), distortions of the pulses because of the charged inductance, transformation of the pulses, and structure of the electron gun.

The development of a gun for a line filled with a dielectric with a large value of ϵ is a complex problem. Usually the used design of the gun [1, 2] does not allow, in the case of transition into a vacuum from a medium with large ϵ , obtaining good

agreement with the oscillator of nanosecond pulses owing to the sharp growth in the reactive component of impedance of the gun. Furthermore, it is difficult to obtain the uniform distribution of the potential along the high-voltage insulator. Therefore, we conducted special studies on the creation of a gun capable of operating in a medium with large ϵ .

Table

	ЭСУ-0	ЭСУ-1
3 Энергия, Мэв	0,8	2,0
4 Ток пучка, кА	20	50
5 Длительность импульса, нсек	35	40
6 Режим работы	7 Одиночные импульсы	
<u>8 Генератор импульсных напряжений (ГИН)</u>		
9 Число ГИН-400-0,06/5	4	6-8
10 Ударное напряжение, Мэв	0,8	1,2-1,6
11 Ударная емкость, нФ	12	8-6
12 Индуктивность, мкГн	5	7-10
<u>13 Двойная формирующая линия (ДФЛ)</u>		
14 Диаметр электродов D_1, D_2, D_3 , см (см. рис. 1)	41; 19; 9;	60; 20; 10
15 Длина, см	80	90
16 Импеданс внутренней линии, см	7	6,5
17 Импеданс внешней линии, см	7	3,8
18 Зарядное напряжение, Мэв	0,8+0,6	1,3-1,5
19 Максимальная напряженность, кВ/см	250	200
<u>20 Трансформирующая линия (ТЛ)</u>		
21 Входной импеданс, ом	14	10,3
22 Коэффициент трансформации	1,46	1,85
23 Длина, см	80	150
<u>24 Электронная пучка</u>		
25 Импеданс, см	30	30
26 Число игл	1-5	1-5
27 Вакуум, мм.рт.ст.	10^{-7}	10^{-7}

KEY to Table: 1) ESU-0; 2) ESU-1; 3) Energy, MeV; 4) Beam current, kA; 5) Pulse duration, ns; 6) Mode of operation; 7) Single pulses; 8) Oscillator of pulsed voltages (GIN); 9) Number GIN-400-0.06/5;

10) Impact voltage, MV; 11) Impact capacitance, nF; 12) Inductance, μ H; 13) Double shaping line (DFL); 14) Diameter of electrodes D_1 , D_2 , D_3 in cm (see Fig.1); 15) Length, cm; 16) Impedance of internal line, cm; 17) Impedance of external line, cm; 18) Charged voltage, MV; 19) Maximum strength, kv/cm; 20) Transforming line (TL); 21) Input impedance, ohms; 22) Coefficient of transformation; 23) Length, cm; 24) Electron beam; 25) Impedance, cm; 26) Number of needles; 27) Vacuum, mm Hg.

Finally, developed is a design of a gun (Fig. 1) which provides the simultaneously sufficiently good agreement and distribution of potential along the high-voltage insulator. The presence in the system of the dielectric with a comparatively great conductivity makes it possible to avert a sectioned insulator, which substantially simplifies its manufacture.

Used as a source of electrons are from 1 to 5 tungsten needles with the radius of rounding of 0.1 mm manufactured by the method of electropolishing from a wire ϕ 2-3 mm. There is the possibility of an accurate change in the anode-cathode distance for the control of impedance of the gun.

The design, calculations and investigations of the nano-second generator and gun are examined in detail in separate reports.

Discussion

A.A. Vorob'yeva. Did you attempt to use water in your devices?
B.N. Yablokov. The use of water in double shaping lines is possible with a very good quality of water (specific resistance of $\gg 10^6$ ohm cm). However, it is very complicated to work with such water. It is difficult to preserve the good qualities of the water in metallic volumes. In this case the line should be equipped with a continually acting system of ion-exchange cleaning. Furthermore, with the use of water the line on a pulse duration of the order of 40 ns becomes short, and with a voltage of the order of 1 MeV its diameter becomes comparable with the length. Such a line is transformed into a condenser.

V.G. Bagramov. What ensures the stability of operation of the

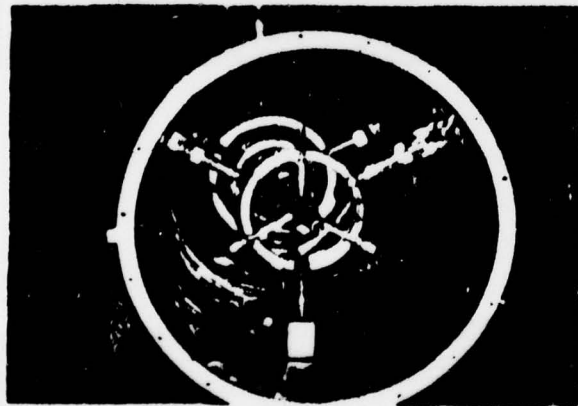

Fig. 4. Model of an electron high-current accelerator ESU-0.
a - general view; b - internal part of the line from the side of
the load.

multispark gap?

B.N. Yablokov. As yet we have not obtained a multispark operation of the discharger. However, we hope that with sufficient power in the sparks and spacing of the igniting sparks in the space it will be possible to achieve a multispark operation of the discharger. Now our sparks will be broken down with an accuracy of 2 ns.

S.B. Vasserman. Why do you consider that a sectioned tube is more complex than a whole one, and from what kind of material is it proposed to manufacture the whole insulator?

B.N. Yablokov. The insulator of the gun is made from plastic. It is possible to turn an insulator from one piece in our case, and this is simple than to gather it from a number of rings.

Yu.P. Vakhrushin. What is the electrical strength of the glycerine in your operating modes?

B.N. Yablokov. According to our data, a breakdown of the glycerine of areas of electrodes $\sim 10^4 \text{ cm}^2$ approaches at field strengths of 230-250 kV/cm.

V. Khaync. What kind of emittance does the gun have?

B.N. Yablokov. We still have not measured the emittance of the gun. The work with it has just started.

V.L. Komarov. What magnitude of the electron beam did you obtain on the model?

B.N. Yablokov. According to the preliminary measurements, the magnitude of the current consists of 500 A.

V.G. Bagramov. Of what type is the transforming line?

B.N. Yablokov. The transforming line is of the exponential type. This is discussed in detail in the next report.

Bibliography

1. S.E. Graybill, S.V. Nablo. IEEE Trans. on Nucl. Sci., 1967, NS-14, No 3, p. 782.
2. T.H. Martin. IEEE Trans. on Nucl. Sci., 1969, NS-16, No 3, p. 59.

26. A HIGH-POWER NANOSECOND GENERATOR

L.N. Kazanskiy, B.N. Yablokov

(Physics Institute im. P.N. Lebedev of the Academy of Sciences of the USSR)

The generator is designed for feeding power to the auto-emission electron gun (EP) of apparatus ESU-1 by single pulses with the following parameters:

Voltage.....2MV

Current.....50 kA

Pulse duration.....35 ns

Duration of front (shear).....10-12 ns

The generation of the output pulse is accomplished according to the known scheme [1, 2] with the use of a double shaping line (DFL)* [3], which is charged by the resonance method from the Arkad'yev-Marks generator [GIN]. However, the generator has certain characteristics connected with the striving to decrease maximally the dimensions of the apparatus.

In the first place, used is a liquid polar dielectric with a high dielectric constant - glycerine ($\epsilon = 42$). Secondly, the pulse of the DFL is transformed for decreasing the voltage of the charge of the DFL. Thirdly, the spark gap of the DFL is included between the grounded electrode at the point where to the latter

* In foreign literature the DFL is known under the name of Blumlein.

the voltage from the GIN is fed. Such a position facilitates the control of the spark gap and provides a "cutting off" of the GIN from the EP and DFL after the commutation of the latter.

A schematic diagram of the generator is given in Fig. 1. The DFL consists of two lines Λ_1 and Λ_2 connected with each other at the input of the transforming line (TL), which is made in the form of a smooth exponential transition (see the present collection, page 00, Fig. 1). The charge of line Λ_2 is carried out through a spiral short-circuiting line (KL). All the elements of the generator, with the exception of the GIN, have a coaxial fulfillment, which makes it possible to use the grounded electrode as a shield and decrease the fringe effects.

2. Selection of the parameters and design of the generator

With the energy yielded to the beam of $\sim 3.0-3.5$ kJ in the pulse, the energy stored in the DFL, taking into account the mismatch and losses, should consist of $W \approx 5$ kJ. The voltage of the DFL relative to the voltage on the EP is determined by the selection of the TL parameters. If the TL and DFL are filled with an identical dielectric ($\epsilon_{\Lambda \Phi \Lambda} = \epsilon_{TL}$), then the lengths of these lines are connected with the relation [4]

$$l_{TL}/l_{\Lambda \Phi \Lambda} = 2t_3/\tau = (l_{TK})^2/(\Delta u/u), \quad (1)$$

where t_3 is the delay of the TL; K - the coefficient of transformation of voltage; $\Delta u/u$ - taper of the vertex of the pulse at the output of the TL. Assuming $\Delta u/u = 0.1$ and $l_{TL}/l_{\Lambda \Phi \Lambda} = 1$,

we get $K = 1.4$. Thus the voltage of the DFL should consist of 1.4 MV, and the capacitance $C_{\Lambda \Phi \Lambda} \approx 5000$ pF.

To increase the pulsed power, the pulse duration (τ) and output impedance of the DFL ($Z_{\text{вых}} = Z_1 + Z_2$) must be selected as small as possible

$$P = \frac{W}{\tau} = \frac{U^2}{Z_1 + Z_2} \quad (2)$$

Here Z_1 and Z_2 are the wave impedances of Λ_1 and Λ_2 . However, their decrease is limited by the permissible duration of fronts of the pulses and inductance of the spark gap (L_p). Assuming

$t_p \leq 0,2\tau$ and considering that $t_p \approx 2,2 L_p/Z_1$, we obtain when $Z_1 = Z_2 = Z$

$$\tau > 11L_p/Z_1 - 4,7(W/L_p)^{0,5} u^{-1}. \quad (3)$$

Hence it follows that when $L_p > 2 \cdot 10^{-8}$ H (a quantity which is hardly possible to decrease when $u > 10^6$ V) $\tau \geq 35$ ns and $Z \geq 7$ ohms.

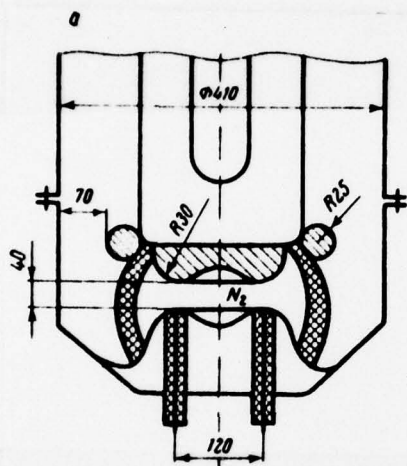

Fig. 1. Schematic diagram of the generator

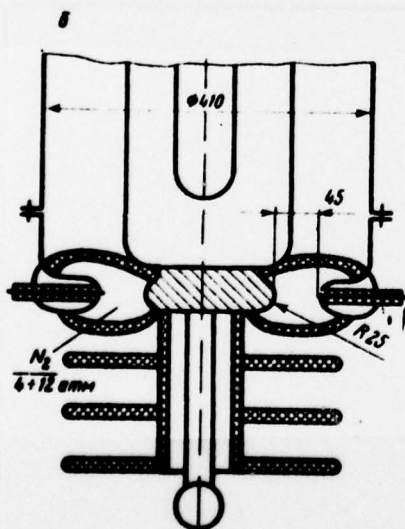

Fig. 2. Spark gap of the double shaping line of axial (a) and radial (b) types.

The selection of the dielectric of the DFL and its geometry, i.e., the ratios of diameters of the coaxial electrodes $a = D_1/D_2 = D_2/D_3$ is fulfilled from the condition of the maximum specific energy content (W/V) at the assigned $Z_1 = Z_2^*$. The electrical strength of all the dielectrics are initially assumed to be identical. Using the known relations, for coaxial lines we can obtain

$$W/V = \frac{60}{\pi c} \frac{\epsilon^2}{Z^2} \frac{(\ln a)^3}{a^4} = \text{const} \frac{(\ln a)^3}{a^4}, \quad (4)$$

where V is the total volume of the DFL. The maximum energy content is obtained when $a_{opt} = 2.12$, and the optimal dielectric constant

$$\epsilon_{opt} = (60 \ln a_{opt} / Z)^2. \quad (5)$$

Selected for our generator are $a = 2.12$ and glycerine ($\epsilon = 39-45$).

It is interesting to note that with the assigned wave impedances of the DFL there is the definite optimal dielectric constant of the dielectric which fills it. For an illustration let us cite the following example: for $Z_1 = Z_2 = 7$ ohms and $\tau = 35$ ns the volume of the DFL is 20% greater with the use of water in comparison with glycerine at equal maximum strengths of the electrical field.

Based on the considerations given above, we designed and are making a model of the generator the parameters and basic dimensions of which are given in Table 1. For the model spark gaps of the DFL of two types are made: radial and axial (Fig. 1). The spark gaps are trigatrons with 6-10 keep-alive electrodes for ensuring a multispark mode of operation [5].

The charged GIN is built from four standard GIN-400-0.06/5 of the Serpukhov plant: two parallel columns, two pieces in each in series.

*The equality of the wave impedances of λ_1 and λ_2 is not necessary in principle, but it is necessary for the total matching of the DFL with the load.

Table 1

1 Узел генератора	2 ДФЛ	3 ТЛ
4 Диэлектрик	7 Глицерин ($\epsilon = 42,5$)	
5 Емкость, пФ	5000	800
6 Волновое сопротивление, ом	14	14-30
8 Коэффициент трансформации	-	1,46
9 Длительность резонансного заряда, мксек	0,8	-
10 Длительность импульса, нсек		35
11 Диаметр электродов, см	9; 19; 41	9; 16; 41
12 Длина, см	85	100
13 Максимальная напряженность поля при зарядном напряжении 1,4 Мв, кВ/см	420	600

KEY: 1) Assembly of generator; 2) DFL; 3) TL; 4) Dielectric; 5) Capacitance, pF; 6) Wave impedance, ohms; 7) Glycerine; 8) Coefficient of transformation; 9) Duration of resonance charge, μ s; 10) Pulse duration; ns; 11) Diameter of electrodes, cm; 12) Length, cm; 13) Maximum field strength with voltage charge of 1.4 MV, kV/cm.

3. Investigations

Measured in the range of 0.1-100 MHz were the dielectric constant ϵ and quality $Q = 1/45$ of glycerine, water and alcohols (Fig. 2). The passage of short pulses (10-50 ns) through lines filled with these dielectrics was investigated. The best characteristics are possessed by thoroughly cleaned water ($\rho \geq 10^6$ ohms/cm); glycerine has acceptable data if the duration of the fronts of $\sim 10-12$ ns is permissible.

The process of the charge of the DFL for selection of the optimal parameters of KL ($Z_{KL} = 110$ ohms, $\tau t_3 = 17$ ns, $L_{KL} = 1.9$ μ H) and of the estimate of the previous pulse voltage on the EP was modeled. The process of the charge is checked on the model (Fig. 3), the maximum voltage of the DFL consists of $\sim 120\%$ of the total charged voltage of the GIN, and the voltage of EP during the charge is $< 10\%$ of the voltage of the working pulse.

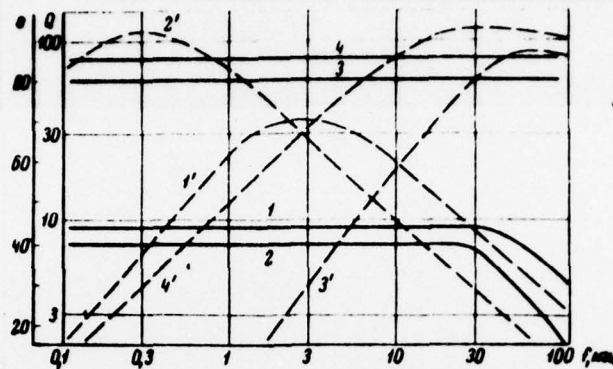

Fig. 3. Frequency dependences of the dielectric constant ϵ_1 (solid lines) and quality $Q = 1/\text{tg } \delta$ (dashed lines): 1.1¹ - technical glycerine ($\rho = 1.7 \cdot 10^6$); 2.2¹ - glycerine "r" ($\rho = 60 \cdot 10^6$); 3.3¹ - distilled water ($\rho = 10^4$); 4.4¹ - thoroughly cleaned water ($\rho = \sim 10^6$); ρ - volume resistance [ohms.cm].

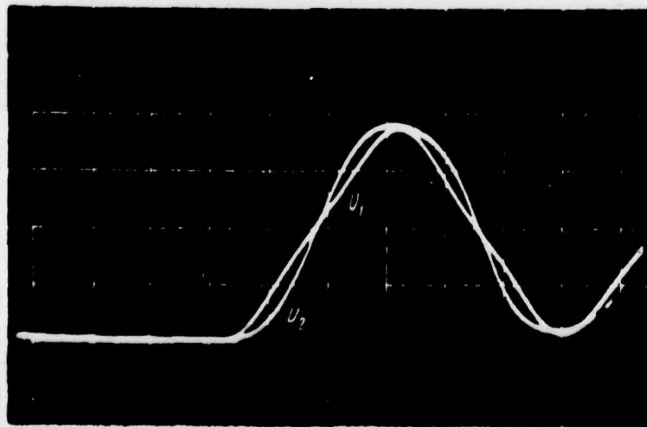

Fig. 4. Charged voltages on lines of DFL V_1 on Π_1 and V_2 on Π_2 . Scale along the horizontal is $0.2 \mu\text{s/cm}$ and along the vertical, 200 kV/cm .

Results of the measurement of the inductance of spark gaps on the number of needles, which were simulated by short wires $\phi 1.5 \text{ mm}$, are given in Table 2. The need to provide a multispark operation of the spark gap and advantages are evident.

Table 2

1 Число каналов	1	2	3	4	5	6
2 Радиальный разрядник, зазор 4,5 см	60	28	17	12	11	9,5
3 Аксиальный разрядник, зазор 4,0 см	75	40	32	29	26	24

KEY: 1) Number of channels; 2) Radial spark gap, gap of 4.5 cm; 3) Axial spark gap, gap of 4.0 cm.

During tests of the model for electrical strength, the charged voltage on the DFL was raised to 600 kV. Breakdowns in the spark gap were not observed at a pressure of $N_2 \sim 4$ atm (the spark gap is tested at 10 atm).

At 600 kV on the second maximum of the charged voltage, there were breakdowns in the glycerine on the end of the DFL ($E \approx 230$ kV/cm).

The manufacture of the basic generator ($U_{\text{ан}} = 1.4$ MV; $U_{\text{он}} = 2.0$ MV) is being started at the present time. The maximum field strength in it is 200 kV/cm, the external diameter of DFL is 600 mm, and its wave impedances $Z_1 = 3.8 \Omega$ and $Z_2 = 6.5 \Omega$.

Discussion

A.A. Vorob'yev. How much did I understand that the microsecond range interest you?

L.N. Kazanskiy. The charge of the shaping line is accomplished during 0.4-0.6 μ s; the duration of the output pulse proceeding to the electron gun is 30-50 ns on a level of 0.5 of the amplitude.

V.G. Davydovskiy. What kind of efficiency of the system do you expect to obtain? How many pulses per unit time can the system provide?

L.N. Kazanskiy. The efficiency of the relative energy stored in the GIN should be approximately 50%. The repetition frequency is determined by the used GINs (GIN - 400-0.06/5). The maximum frequency is 2 pulses/min.

Bibliography

1. W.T. Link. IEEE Trans. on Nucl. Sci., 1967, NS-14, N 3, p.777.
2. T.H. Martin. IEEE Trans. on Nucl. Sci., 1969, NS-16; N 3, p.7.
3. Я.С. Никоки. Импульсные устройства. М., "Сов. радио", 1959.
4. И. Льюис и Ф. Эулс. Миллимикросекундная импульсная техника. ИЛ, 1966.
5. R. Buser et al. Electronics, 1968, 72, p.74.

27. RESEARCH OF INTENSE ELECTRON BEAMS ON THE RIUS-5 ACCELERATOR

Ye.A. Abramyan, S.B. Vasserman, V.G. Votintsev, V.M. Dolgushin, A.N. Lukin, B.G. Shklyayev (Institute of Nuclear Physics of the Siberian Branch of the Academy of Sciences of the USSR)

The RIUS-5 accelerator, intended for the obtaining of beams of relativistic electrons in short (40-0 ns) pulses with currents of up to 30 kA, was constructed and started at the Institute of Nuclear Physics of the SO [Siberian Branch] of the AS of the USSR in 1969 [1].

Conducted during the recent year were works on the improvement of the design of the accelerator and investigation of parameters of the beam. At the present all the units and systems of the accelerator operate stably at a voltage of the high-voltage generator up to 8 MV and a voltage on the accelerator tube of up to 5 MV. The repetition frequency of the pulses is one per minute (with operation with a high beam into the atmosphere).

The accelerator is made standard for the apparatuses of such type of design: the source of high voltage charging the high-voltage capacitor ^{is} a spark gap-peaker with an igniter, and an acceleration tube with a cold cathode. Used as the source of high voltage is a pulse generator on connected circuits (Tesla transformer). The insulating medium is a mixture of gases and nitrogen in the ratio of 1:1 with a total pressure of 15 atm. A schematic cross section of the accelerator is shown on Fig. 1. A description of the design and operation of the apparatus is

given in [1].

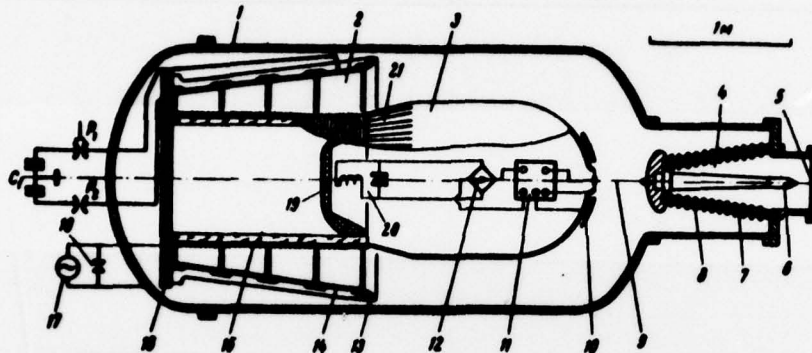

Fig. 1. Schematic cross section of the apparatus

1 - Reactor; 2 - Transformer; 3 - High-voltage electrode (conductor); 4 - Accelerator tube; 5 - Exhaust window (anode); 6 - cathode; 7 - Insulator; 8 - Electrode of tube; 9 - Spark gap peaker; 10 - Capacitance divider; 11 - Igniter unit; 12 - Rectifier; 13 - Electrode; 14 - Primary winding; 15 - Secondary winding; 16 - Insulation base; 17 - Generator of igniter feed; 18 - Shunting spark gap; 19 - Electrode of capacitance shielding; 20 - Oscillatory circuit; 21 - "Transparent" part of the conductor; C_1 - condenser bank; P_1 and P_2 - air spark gaps.

Described in the report are the new design and features of the operation of the sectioned accelerator tube and the exhaust device with a longitudinal magnetic field, and results of studies of a number of parameters and characteristics of the accelerated beam are also given.

Accelerator tube and exhaust device

The accelerator tube (Fig. 2) consists of insulating rings made from plastic and divided electrodes from duralumin with rubber packings of the joints. The total number of sections is 13, and the length of the tube is about 75 cm. The structure of the tube is made according to the type of sectional tubes, which successfully operate in pulsed accelerators with a thermo-emission cathode [2] with microsecond voltage pulses. In conformity with

recommendations of A. Watson [3], on the vacuum side the surface of the insulator is made conical. The geometry of the tube as a whole was selected on an electrolytic bath in such a way that the distribution of voltage along the sections would be close to being uniform.

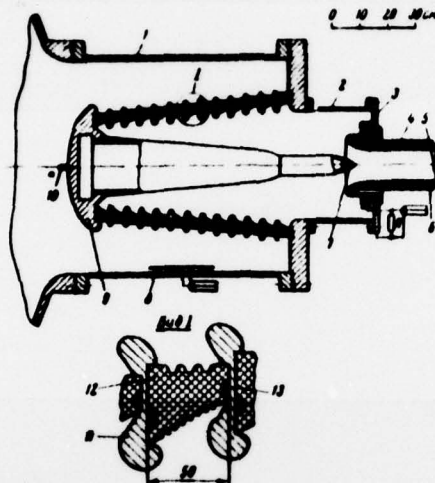

Fig. 2. Accelerator tube and exhaust device. 1 - housing; 2 - vacuum chamber; 3 - Rogowski loop; 4 - housing of exhaust device; 5 - exhaust window; 6 - solenoid; 7 - emitter; 8 - voltage sensor on the tube; 9 - high-voltage electrode of the tube; 10 - tip; 11 - electrode of the tube; 12 - insulator; 13 - packing.

As was indicated above, the tube successfully operates at voltages on it of up to 5 MV. However, there is no complete certainty of the fact that the accepted materials and geometrical shapes of the insulating rings and metallic electrodes are optimal. At present investigations are being started on the electrical strength of the sections different in material, dimensions and geometry on a high-voltage (up to 1 MV) nanosecond test bench.

The necessary condition for the normal operation of an accelerator tube is, as is usual, its preliminary conditioning. An attempt to conduct conditioning of the tube in the operating mode by means of a gradual increase in the voltage did not give a positive result: the effect of the conditioning was absent. The

energy released in this case in the channel of the discharge consists of ~ 1 kJ (at a voltage of the generator of ~ 3 MV) apparently, is extremely great. Successful conditioning of the tube is carried out with a parallel connection of the sections and the connecting of them to the high-voltage electrode of the generator. In this case the energy released in the channel of the discharge does not exceed 10 J. The conditioning of the tube directly in the accelerator proves to be possible owing to the fact that the voltage of the generator is easily regulated practically from zero. This is one of the advantages of a pulse generator on connected circuits as compared with the Marks generator.

The pre-impulse voltage, induced on the accelerator gap (owing to the capacitance division) up to the triggering of the spark gap-peaker (Fig. 3), can lead to a vacuum breakdown in the gap, which as a rule affects the geometry and other parameters of the beam. To prevent a vacuum breakdown of the gap in the pre-impulse stage, we take measures both with respect to the lowering of the magnitude of the induced pre-impulse voltage and with respect to the increase in the electrical strength of the accelerator gap.

For the purpose of decreasing the potential induced on the high-voltage electrode 9 of the tube (Fig. 2), the latter is shifted deep into the housing 1, and here the gap of the spark gap-peaker 9 (Fig. 1) is increased. A tip 10 (Fig. 2) is used for the matching of the electrical strength of the spark gap-peaker with the strength of the high-voltage gap of the generator. The magnitude of the induced voltage onto the tube consists of $\sim 2.5\%$ of the high voltage of the generator.

The exhaust device of the tube, shown on Fig. 2, allows placing window 5 at a considerable distance from the emitter at sufficiently high strengths of the electrical field on the cathode. The longitudinal magnetic field formed by the solenoid 6 smoothly grows in magnitude up to 3-4 kG and further remains approximately constant up to the exhaust window. The beam which is diverging from the cathode becomes then parallel. Such an exhaust device

has considerable advantages over the standard system of the exhaust (see Fig. 1). The dimension of the beam on the anode can easily be regulated; the electrical strength of the gap in the pre-impulse stage noticeably grows, preventing the breakdowns ("cutoffs" of the voltage induced onto the tube); the processes on the anode, conditioned by the bombarding by the electron beam, have a weak effect on the lowering of the resistance of the cathode-anode gap; the insulator of the tube is considerably better shielded from the dust gathering by metal flying from the anode.

The first tests of the exhaust device with the longitudinal growing magnetic field were passed successfully.

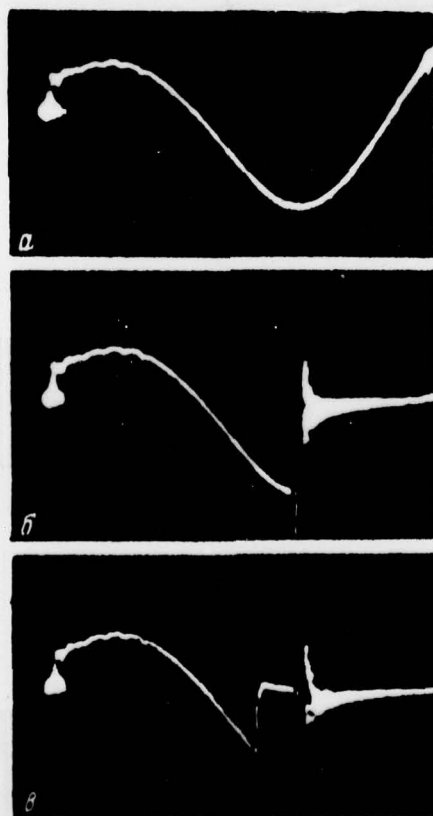

Fig. 3. Voltage on the accelerator tube during the whole cycle of operation of the apparatus. a - spark gap-peaker did not trigger; b - spark gap triggered (a jump in the voltage on the tube is evident); c - in the pre-impulse stage there occurred a "cutoff" of the voltage (breakdown of the vacuum gap). Sweep is 5 ms/cm.

Results of measurements of parameters of the beam

The standard oscillograms of pulses of the accelerating voltage and current (exhaust system is standard) are shown on Fig. 4. With the magnitude of the gap emitter-anode of 4 cm and voltage of the generator of 8 MV, the amplitudes of the beam current and accelerating voltage consist of 50 kA and 3.5 MV. The energy of the beam in the pulse measured by a calorimeter installed behind foil is equal to 3 kJ.

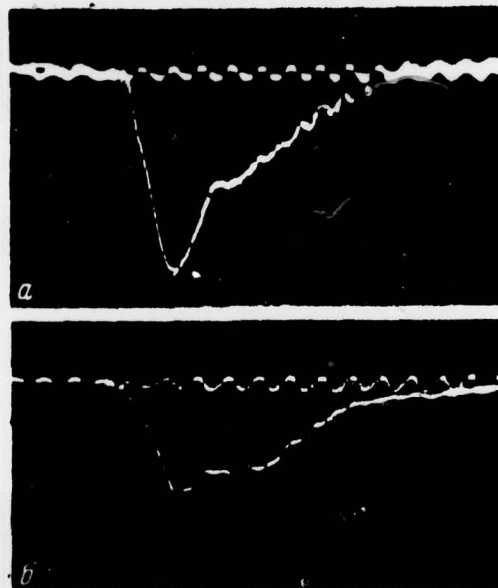

Fig. 4. Shape of pulses of accelerating voltage a) and current b) of the beam. Marks are 100 MHz.

The changes occurring in the accelerator gap in the period of passage of the beam of electrons explain the higher values of current in the middle and end of the pulse as compared with current at the beginning of the pulse at those same voltages. The maximum voltage on the gap is achieved in 15 ns from the beginning of the pulse, and it is apparently possible to consider that by this moment the characteristics of the beam are still determined only by the emission properties of the cathode and the geometry of the accelerating gap. Values of the beam current at the maximum accelerating voltage in the range of $u_m = 1-4$ MV

are well approximated by the relation

$$j_m = k U_m^{3/2},$$

where k is the coefficient dependent on the geometry of the gap, emitter and material of the latter. For an emitter of stainless steel, the shape of which is shown on Fig. 5, b, with the magnitude of the gap up to the anode of 4 cm, $k = 2.240 \cdot 10^{-12} \text{ A/V}^2$. It should be noted that the cleanness of the surface of the emitter and the form of the edges (sharp or blunted) do not noticeably affect the magnitude k .

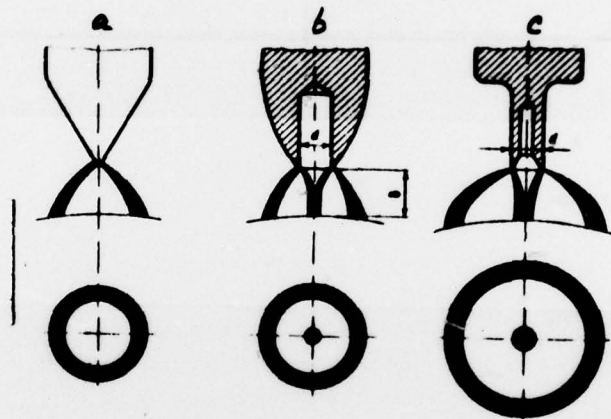

Fig. 5. Trajectories of electrons and shape of the beam on the anode for different emitters. The energy of the electrons $W_e = 1 + 1.5 \text{ MeV}$, $\delta = 2 \text{ cm}$; $d = 1.2 \text{ cm}$.

Figure 5 shows the cross sections of the beam of electrons on the anode at the maximally accelerating voltage in the pulse for different emitters. The ring shape of the section of the beam from the conical emitter is well-known. The expected, on this basis, splitting of the beam on the ring edge and the possibility of a change in the parameter of the beam due to the slope of the edges were confirmed with the investigation of the emitters the shape of which is given in Fig. 5, b and c. The configuration of the sections of the beam was observed on glass plates, which were placed behind aluminum filters which pass only electrons of maximum energies. With an increase in the energy of the electrons the diameter of the beam is decreased.

Discussion

A.N. Lebedev. 1. In what region of energies was there observed the law $5/2$ and of what magnitude was the magnetic field used for the derivation? What is the intrinsic field of the beam, and at what current were the experiments conducted? 3. What maximum current for an energy of 5 MeV was obtained on this gun?

S.V. Vasserman. 1. The law $5/2$ was observed in the region of energies of 1 to 3.5 MeV. The field grew along the axis of the beam to 4 kG. The experiments were conducted with currents of up to 20 kA. Unfortunately, I do not remember the magnitude of the beam's magnetic field. 3. At an energy of 5 MeV the current was about 30 kA.

A.A. Vorob'yev. How is the current from pulse to pulse different, and what is the duration of the continuous operation of this apparatus determined by the thermal mode?

S.B. Vasserman. The scattering from pulse to pulse is within 5%. Since the machine operates with a repetition of once per minute, then the question of thermal overloads did not appear.

I.M. Royfe. From what material is the tube made? Don't you plan to decrease the duration of the front?

S.B. Vasserman. Plastic is used for the insulation rings. The electrodes are manufactured from duralumin. At present the front is equal to 15 ns, and for our purposes it is not necessary to shorten it.

B.N. Yablokov. What is the delay time between the pulse of the trigatron and the main discharge to the tube?

S.B. Vasserman. The delay time was not measured, but the stability of the triggering is good.

N.V. Pleshivtsev. 1. What are the geometrical dimensions of the cathode and its material. 2. Did you operate in a mode with a voltage of less than 1 MV?

S.V. Vasserman. 1. The cathode is prepared from stainless steel and is a cone with different angles. Usually the angle is 60° and the length, 3 cm. The tip had a rounding off. 2. No, we did not.

K.V. Khodatayev. What portion of energy does the beam lose as compared with the energy stored in the battery [bank]?

S.V. Vasserman. In the maximum mode the energy of the bank is 10 kJ, on the high-voltage electrode it is 7 kJ, and in the beam, 3 kJ.

Bibliography

1. Е.А. Абрамян и др. Докл. АН СССР, 1970, 192, № 1, стр. 76.
2. Е.А. Абрамян, С.Б. Вассерман. "Атомная энергия", 1967, 23, вып. 1, стр. 44.
3. A. Watson. J. Appl. Phys., 1967, 38, N 5, p.2019.

DISTRIBUTION LIST

DISTRIBUTION DIRECT TO RECIPIENT

<u>ORGANIZATION</u>	<u>MICROFICHE</u>	<u>ORGANIZATION</u>	<u>MICROFICHE</u>
A205 DMATC	1	E053 AF/INAKA	1
A210 DMAAC	2	E017 AF/RDXTR-W	1
B344 DIA/RDS-3C	9	E403 AFSC/INA	1
C043 USAMIIA	1	E404 AEDC	1
C509 BALLISTIC RES LABS	1	E408 AFWL	1
C510 AIR MOBILITY R&D LAB/FIO	1	E410 ADTC	1
C513 PICATINNY ARSENAL	1	FTD	
C535 AVIATION SYS COMD	1	CCN	1
C591 FSTC	5	ASD/FTD/NIIS	3
C619 MIA REDSTONE	1	NIA/PHS	1
D008 NISC	1	NIIS	2
H300 USAICE (USAREUR)	1		
P005 DOE	1		
P050 CIA/CRS/ADD/SD	1		
NAVORDSTA (50L)	1		
NASA/KSI	1		
AFIT/LD	1		
ILL/Code L-389	1		