

AD-A066 803

COBER ELECTRONICS INC STAMFORD CT
HIGH VOLTAGE NANOSECOND PULSE GENERATOR.(U)
NOV 78 J BAJDA, C ZAVALAS

F/G 9/5

DAAB07-77-C-2641

UNCLASSIFIED

DFLET-TR-77-2641-3

NL

| OF |

AD
A066803

END



END
DATE
FILMED
5-79
DDC



LEVEL

12

RESEARCH AND DEVELOPMENT TECHNICAL REPORT
DELET-TR-77-2641-3 A048616

HIGH VOLTAGE NANOSECOND PULSE GENERATORS

AD A0 66803

J. Bajda
C. Zavalas
COBER ELECTRONICS
7 Gleason Avenue
Standford, CT 06902

DDC
RECEIVED
APR 4 1978
C

DDC FILE COPY

November 1978

Third Quarterly Report for Period 9/1/77 to 6/30/78

DISTRIBUTION STATEMENT

Approved for public release;
distribution unlimited.

Prepared for:
Electronics Technology & Devices Laboratory

ERADCOM

US ARMY ELECTRONICS RESEARCH & DEVELOPMENT COMMAND
FORT MONMOUTH, NEW JERSEY 07703

HISA-FM 196-7.

79 04 02 099

NOTICES

Disclaimers

The citation of trade names and names of manufacturers in this report is not to be construed as official Government indorsement or approval of commercial products or services referenced herein.

Disposition

Destroy this report when it is no longer needed. Do not return it to the originator.

UNCLASSIFIED

SECURITY CLASSIFICATION OF THIS PAGE (When Data Entered)

REPORT DOCUMENTATION PAGE		READ INSTRUCTIONS BEFORE COMPLETING FORM	
1. REPORT NUMBER DELET-TR-77-2641-3	2. GOVT ACCESSION NO. (9) <i>Interim rpt. no. 3</i>	3. RECIPIENT'S CATALOG NUMBER	
4. TITLE (and Subtitle) High Voltage Nanosecond Pulse Generator.	5. TYPE OF REPORT & PERIOD COVERED Final (Triannual) Report 1 Sep 77 - 30 Jun 78	6. PERFORMING ORG. REPORT NUMBER	
7. AUTHOR(s) J. Bajda C. Zavales	8. CONTRACT OR GRANT NUMBER(s) (15) DAAB07-77-C-26417		
9. PERFORMING ORGANIZATION NAME AND ADDRESS Cober Electronics, Inc. 7 Gleason Avenue Stamford, Connecticut 06902	10. PROGRAM ELEMENT, PROJECT, TASK AREA & WORK UNIT NUMBERS (16) 62705 1L762705 AH 94 E1 01		
11. CONTROLLING OFFICE NAME AND ADDRESS USA Electronics Technology & Devices Lab. ATTN: DELET-BG Fort Monmouth, NJ 07703	12. REPORT DATE (17) November 1978		
14. MONITORING AGENCY NAME & ADDRESS (if different from Controlling Office) (12) 27p.	13. NUMBER OF PAGES 16	15. SECURITY CLASS. (of this report) Unclassified	15a. DECLASSIFICATION/DOWNGRADING SCHEDULE
16. DISTRIBUTION STATEMENT (of this Report) Approved for Public Release: Distribution Unlimited			
17. DISTRIBUTION STATEMENT (of the abstract entered in Block 20, if different from Report)			
18. SUPPLEMENTARY NOTES			
19. KEY WORDS (Continue on reverse side if necessary and identify by block number) Pulse Generation Switching Spark Gap Blumlein Avalanche Transistor			
20. ABSTRACT (Continue on reverse side if necessary and identify by block number) This Third Interim Report describes work performed during the period 1 Sep 77 to 30 Jun 78 to develop a set of high voltage nanosecond pulse generators. The objective of the development is a set of pulse generators of small volume, low weight, and high efficiency. Testing of the power supply and modulator for Task A Pulse Generator, operating either single pulse or 15 Hz at a pulsewidth of 125 ns, pulse voltage of 30kV, and pulse current of 1200 amps, has been proceeding. The power supply and modu-			

DD FORM 1473 1 JAN 73

EDITION OF 1 NOV 68 IS OBSOLETE

UNCLASSIFIED

SECURITY CLASSIFICATION OF THIS PAGE (When Data Entered)

393253 79 04 02 099

next page
B

UNCLASSIFIED

SECURITY CLASSIFICATION OF THIS PAGE(When Data Entered)

20. Abstract (continued)

lator were integrated and operated at an intermediate level of 10 kV. The modulator was tested at 30 kV. Preliminary tests on an SCR-magnetic modulator for Task B Pulse Generator, providing a 5 kV, 4 A, 100 ns pulse to the load, were conducted. In addition, a solid state pulse generator providing a 16 kV, 0.5 amp, 6 us pulse to a laser load was designed, built and tested.

microsec

UNCLASSIFIED

SECURITY CLASSIFICATION OF THIS PAGE(When Data Entered)

TABLE OF CONTENTS

	<u>Page</u>
I. INTRODUCTION.	1
II. TASK A.	4
III. TASK B.	6
IV. 16KV PULSE GENERATOR.	7
V. CONCLUSIONS	9

ACCESSION for	
NTIS	White Section <input checked="" type="checkbox"/>
DDC	Buff Section <input type="checkbox"/>
UNANNOUNCED JUSTIFICATION	
BY DISTRIBUTION/AVAILABILITY CODES	
	SPECIAL
R	

LIST OF FIGURES

<u>Figure No.</u>	<u>Title</u>	<u>Page</u>
1.Task A Power Supply.	5
2.Task A Modulator	6
3.Photograph of Task A HV Transformer	7
4.Photograph of Task A Modulator.	9
5.Task B Modulator11
6.Trigger Generator for Magnetic Modulator12
7.16KV Pulse Generator14

ABSTRACT

This Third Interim Report describes work performed during the period 1 Sept. 77 to 30 Jun. 78 to develop a set of high voltage nanosecond pulse generators. The objective of the development is a set of pulse generators of small volume, low weight, and high efficiency. Testing of the power supply and modulator for Task A Pulse Generator, operating either single pulse or 15Hz at a pulse width of 125ns, pulse voltage of 30kV, and pulse current of 1200 amps, has been proceeding. The power supply and modulator were integrated and operated at an intermediate level of 10kV. The modulator was tested at 30kV. Preliminary tests on an SCR-magnetic modulator for Task B Pulse Generator, providing a 5kV, 4A, 100ns pulse to the load, were conducted. In addition, a solid state pulse generator providing a 16kV, 0.5 amp, 6usec pulse to a laser load was designed, built, and tested.

I. INTRODUCTION

This report covers work done during the period 1 Sept. 1977 to 30 June 1978 on Contract DAAB07-77-C-2641 to develop a set of high voltage nanosecond pulse generators. The work is being performed by Cober Electronics in Stamford, Connecticut for the U.S. Army Electronics Command, Ft. Monmouth, New Jersey. The work is directed toward fulfilling the requirements of Technical Guidelines entitled "High Voltage Nanosecond Pulse Generators" dated 27 July 1976. Listed below are the requirements for Task A, Task B, and Task C.

Task A

a. Output Voltage	30KV
b. Peak Current	1200A
c. Prr	15Hz and single pulse
d. Pulse Width (50%)	125ns
e. Rise Time (10% to 90%)	20ns max.
f. Fall Time (90% to 10%)	40ns max.
g. Pulse Energy Output	4.5 joules
h. Pulser Efficiency	90% min. (resistive load)
i. Life	10^6 pulses min.
j. Weight	2.0kg max.

Cober

k. Volume	360cm ³ max.
l. Form Factor	Cylindrical
m. Maximum Outer Diameter	6.5cm

Task B

a. Output Voltage	5kV
b. Peak Current	4A
c. Prr	10,000Hz
d. Pulse Width (90%)	100ns
e. Rise Time (10% to 90%)	10ns max.
f. Fall Time (90% to 10%)	20ns max.
g. Pulser Efficiency	90% min. (resistive load)
h. Pulse Energy Output	0.0023 joules
i. Life	1000 hrs. min.
j. Weight	2.0kg
k. Volume	360cm ³ max.

Task C

a. Output Voltage	1kV
b. Peak Current	1) 15A to charge up C _L = 30pF in 2 nsec 2) 20mA during flat top portion of pulse
c. Prr	15,000Hz
d. Pulse Width (50%)	20ns
e. Rise Time (10% to 90%)	2ns max.
f. Fall Time (90% to 10%)	4ns max.
g. Pulser Efficiency	90% min.

Cober

h. Life	1000 hrs. min.
i. Weight	2.0kg max.
j. Volume	360cm ³ max.

II. TASK A

Presented in Figure 1 and Figure 2 are schematic diagrams for the power supply and modulator for the Task A pulse generator. The 30kV, 1200A, 125ns pulse is formed by discharging a Blumlein circuit with a triggered spark gap. A ringing-choke dc-to-dc converter charges the Blumlein circuit capacitors to 30kV by transforming the 28 volt input.

In the present design, the 30kV output is formed by connecting the three secondary windings of power supply transformer T_1 in series. Each secondary consists of 2500 turns of wire wound over a separate molypermalloy toroid core. The secondary start and secondary finish are terminated in corona rings separated by 0.5 inch. Each core has an outer diameter of 1.33 inches, an inner diameter of 0.76 inches, and a height of 0.46 inches. Adjacent cores are separated by 0.5 inch. The primary winding passes through the center window of all three cores and is insulated to withstand the 30KV potential difference between primary and secondary. The drive winding of transformer T_1 passes through the center of all three cores and over the primary winding. It is insulated for 15kV. Figure 3 shows a photograph of the transformer configuration utilizing two cores with the secondary windings in series.

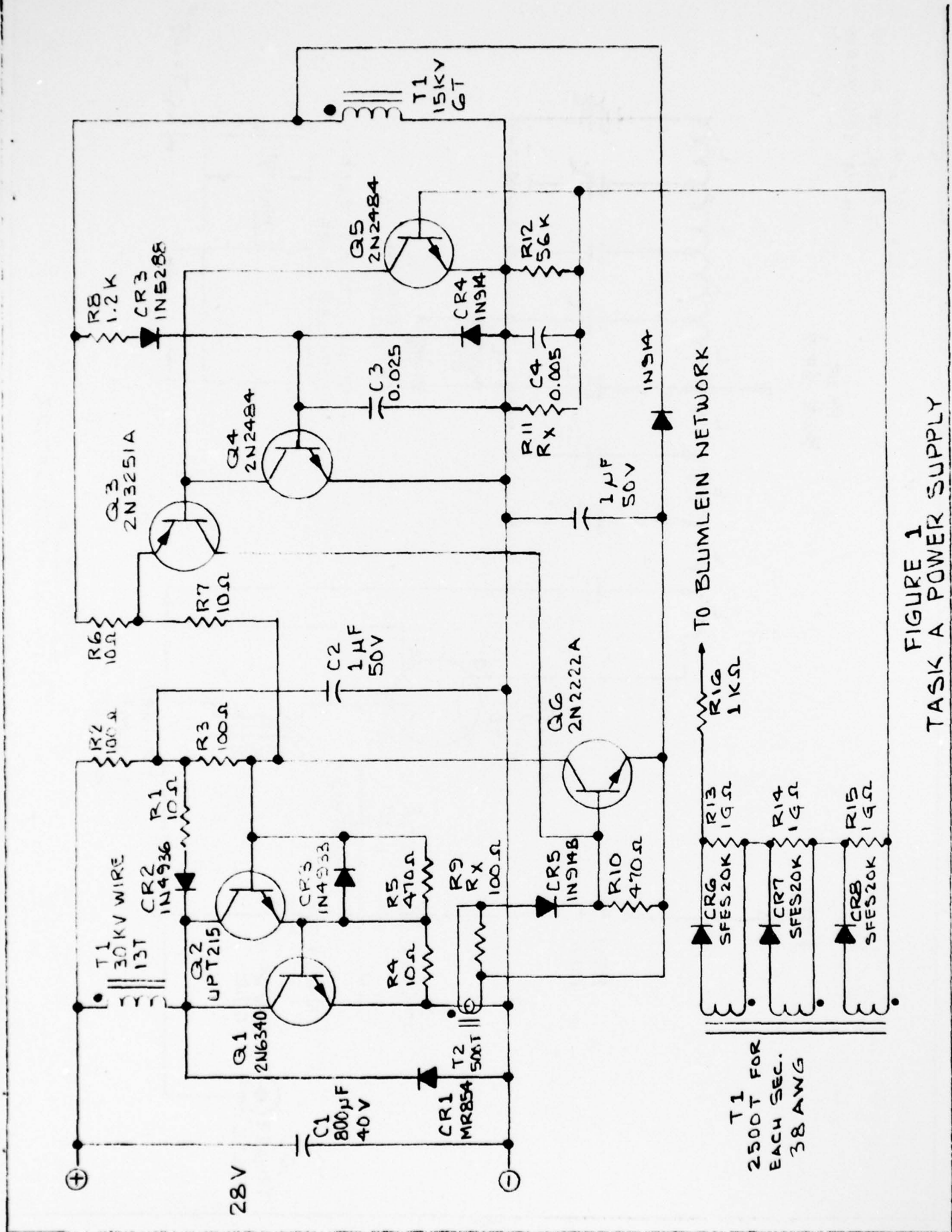

FIGURE 1
TASK A POWER SUPPLY

$L = .195 \mu H$ each
 7 TURNS OF AWG 18
 ON 1/4" COIL FORM

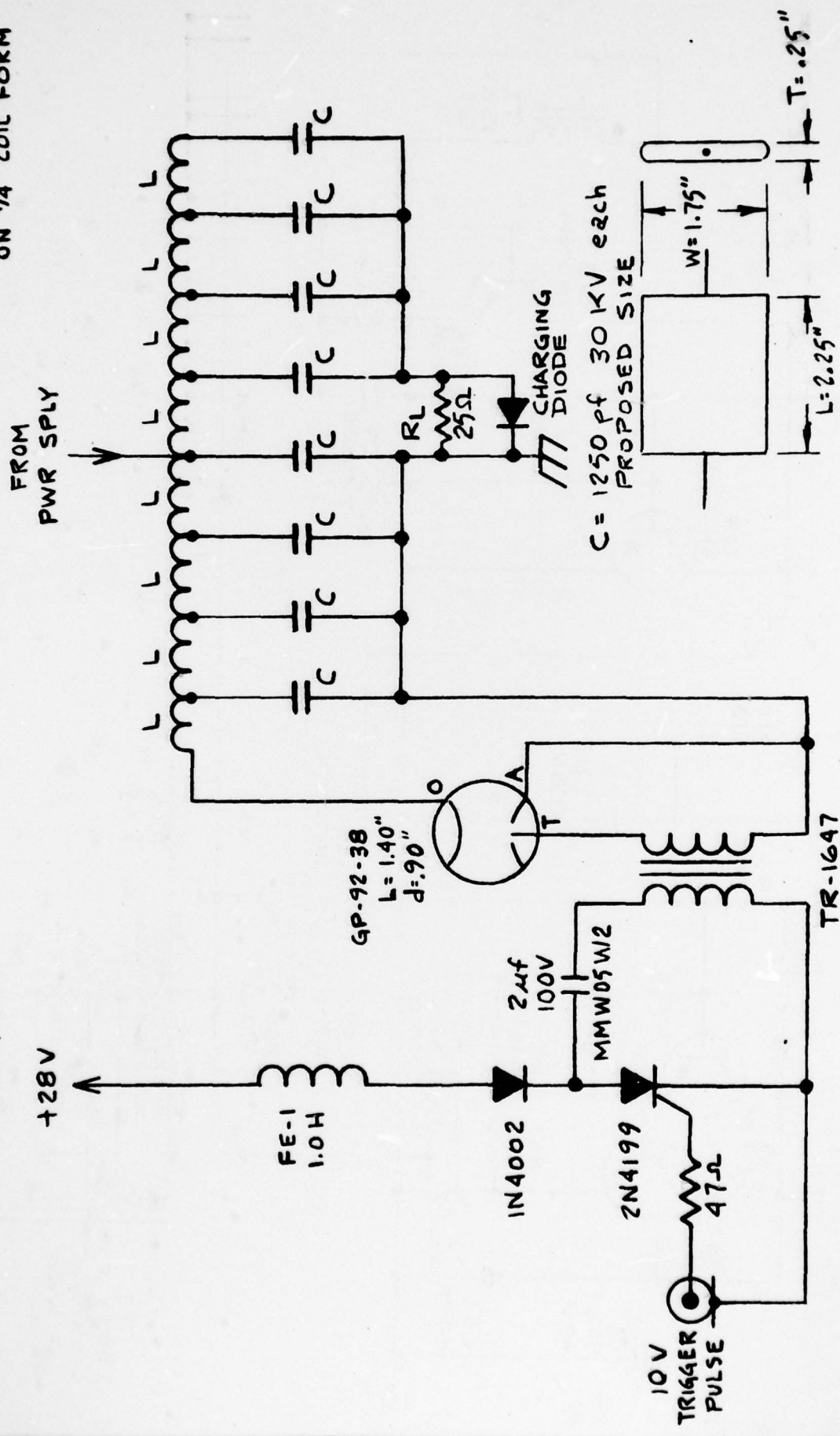

FIGURE 2
 TASK A MODULATOR

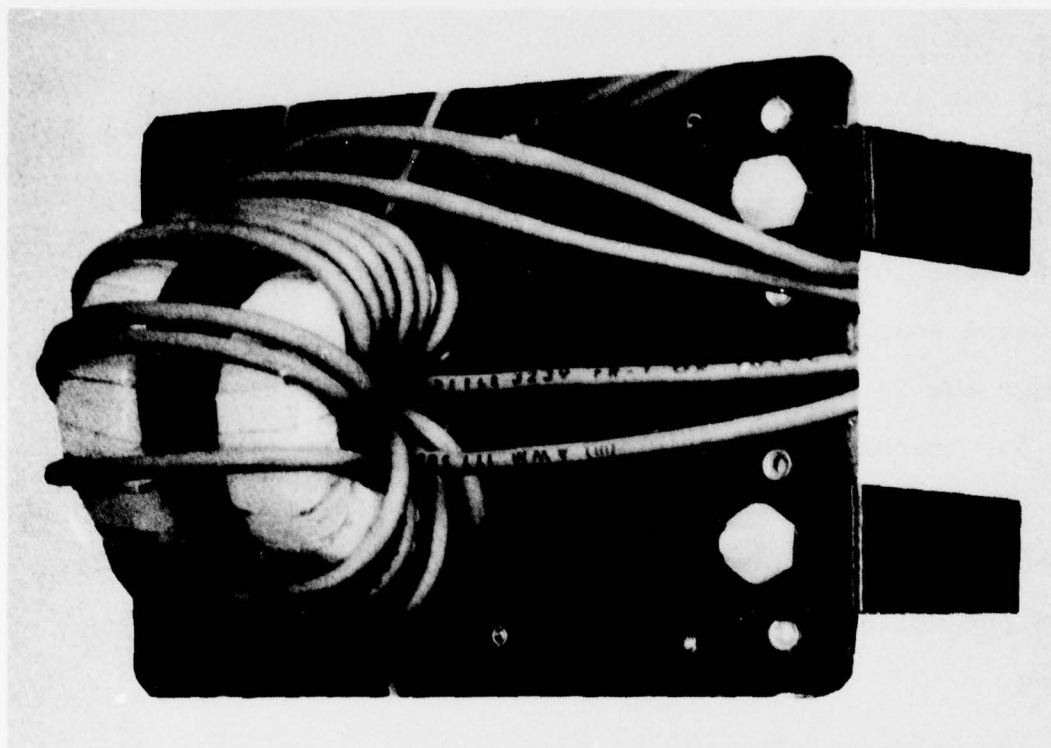

FIGURE 3
TASK A HV TRANSFORMER

Testing on the Task A Pulse Generator was begun by modifying the power supply for 10kV operation. The primary and control windings were wound on one of the three toroids to be used in the 30kV design. The power supply was operated into a 1 megohm resistive load. With an input voltage of 10 volts, an output voltage of 5kV (25 watts average power) was obtained. Next, the power supply was integrated with the modulator and operated at a pulse repetition rate of 15Hz. The Blumlein circuit capacitors were charged to a peak voltage of 10kV during the 67 msec interpulse period. Upon triggering the triggered spark gap, a pulse current of 400A was measured through the 25 ohm load at the output of the modulator.

The transformer configuration utilizing two cores with the secondary windings in series was operated into a 2 megohm resistive load. With an input voltage of 24 volts, an output voltage of 10kV (50 watts average power) was obtained.

The modulator was tested at 30kV with an external supply. A pulse current of 1200 amps at a pulse width of 140ns and pulse repetition rate of 15Hz was measured through the 25 ohm load. The pulse rise and fall time were approximately 40ns. Figure 4 shows a photograph of the modulator breadboard.

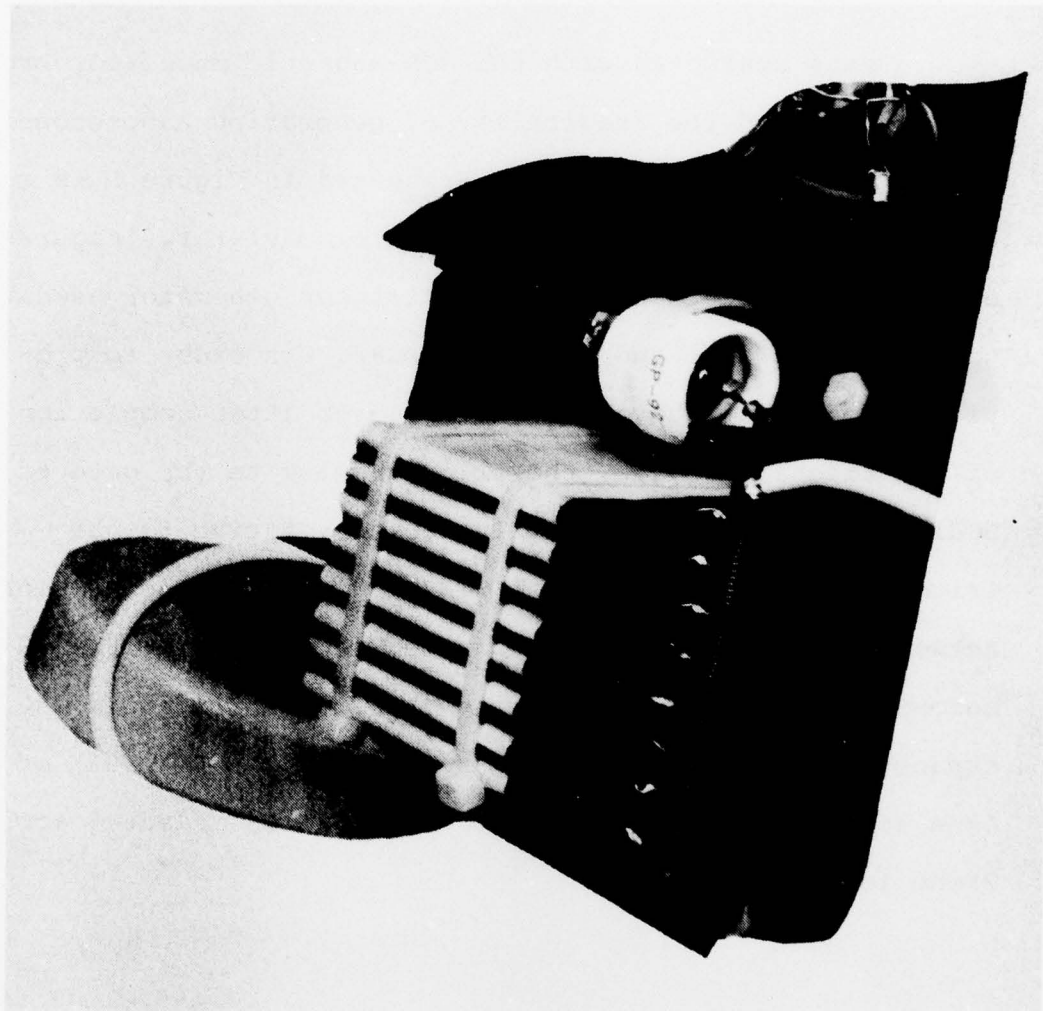

FIGURE 4
TASK A MODULATOR

III. TASK B

Tests conducted with the SCR-magnetic modulator breadboard confirmed the feasibility of generating nanosecond pulses with a 28 volt input. Presented in Figure 5 is a schematic diagram of the SCR-magnetic modulator. Figure 6 shows a schematic diagram of the trigger generator used to gate charging SCR1 and discharge SCR2. In order to provide time for discharge SCR2 to recover after completion of the discharge cycle, the trigger pulse to the gate of SCR1 was delayed approximately 20usec relative to the trigger pulse to the gate of SCR2. With a single section network consisting of the saturated inductance of the secondary winding of saturating transformer T_1 and a 250 pF capacitor, a 4kV pulse having a pulse width (90%/50%) of 40ns at a pulse repetition rate of 5KHz was measured across a 2Kohm load.

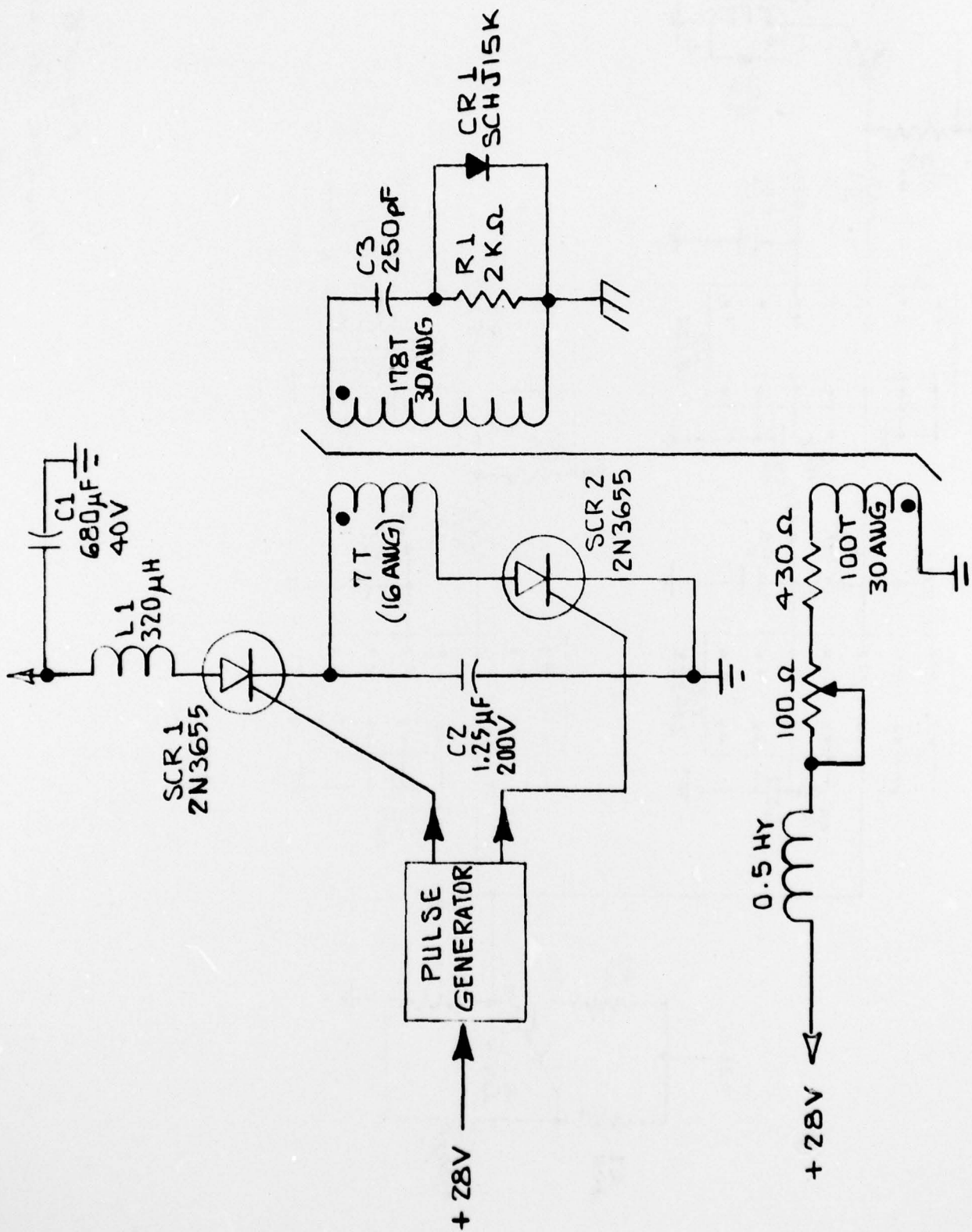

FIGURE 5
TASK B MODULATOR

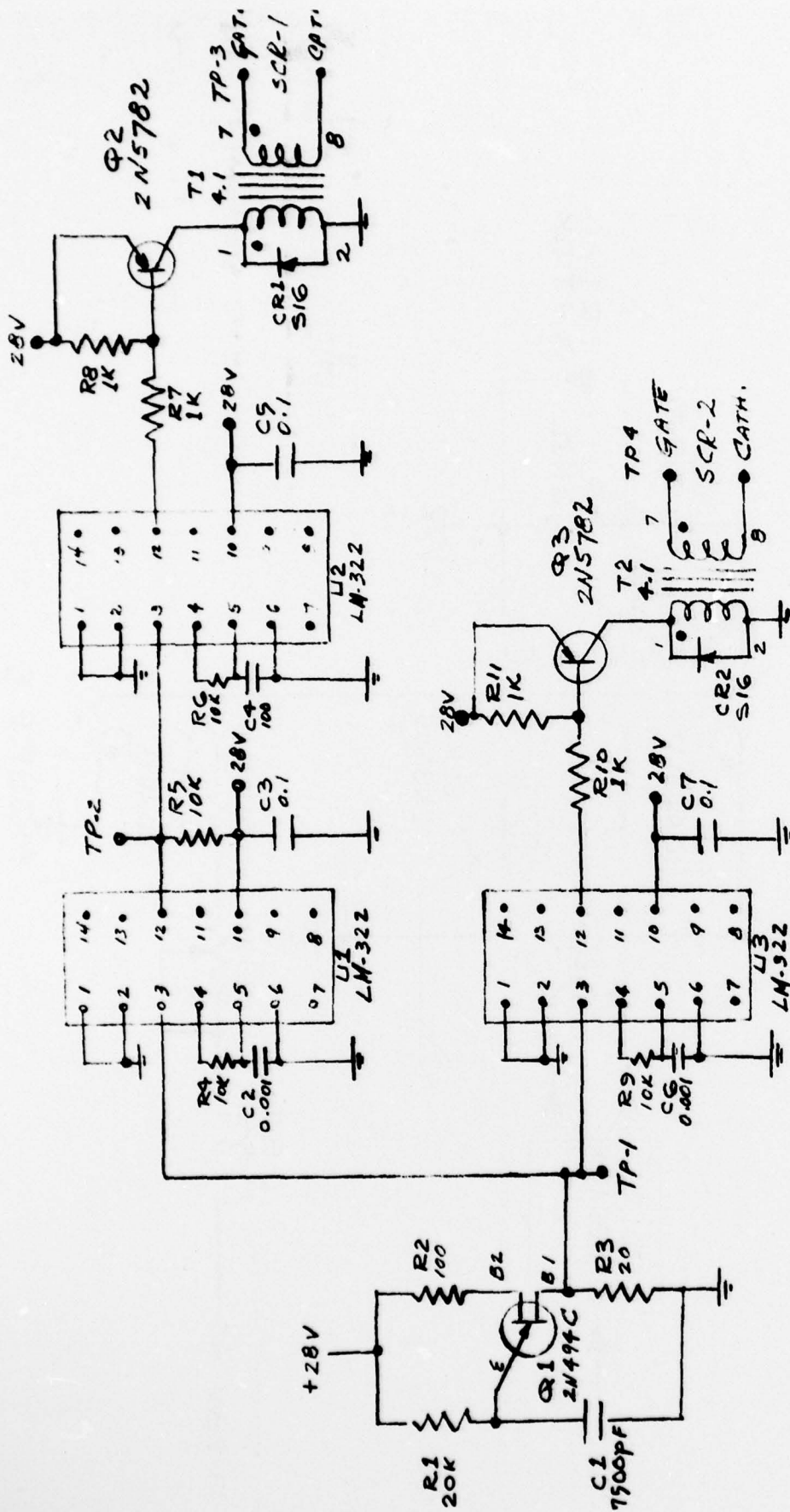

FIGURE 6
TRIGGER GENERATOR FOR
MAGNETIC MODULATOR

IV. 16KV PULSE GENERATOR

As part of the Task B effort, a higher voltage, lower current exploratory version of the original Task B pulser was investigated. The solid-state pulse generator to trigger the laser tube was designed, built, and tested. Operating from a 115VAC input, the output was a 16kV, 6usec pulse capable of driving a 0.5 amp load. Figure 7 shows a schematic diagram of the pulser generator.

The 115 volt line is rectified and doubled by a full wave doubler circuit. The rectified voltage, approximately 300 volts, is applied to the primary of a step-up pulse transformer by six Darlington transistors connected in parallel. To speed up the turn off process, external anti-saturation diodes are used at the bases.

Control circuit power is derived from one 9 volt and two 1.5 volt batteries. The batteries are adequate for the designed life of the pulser and eliminate the need of a separate transformer to provide the two voltages. The 9 volt alkaline battery is rated at 100mA for 1 hour. The 1.5 volt carbon-zinc batteries are rated at 100mA for 8 hours. To conserve power and to prevent damage to the Darlington transistors, the battery switch must be turned on shortly prior to the application of 115VAC input power and turned off only after removal of 115VAC input.

TTL crystal oscillator U1 generates a 10KHz clock

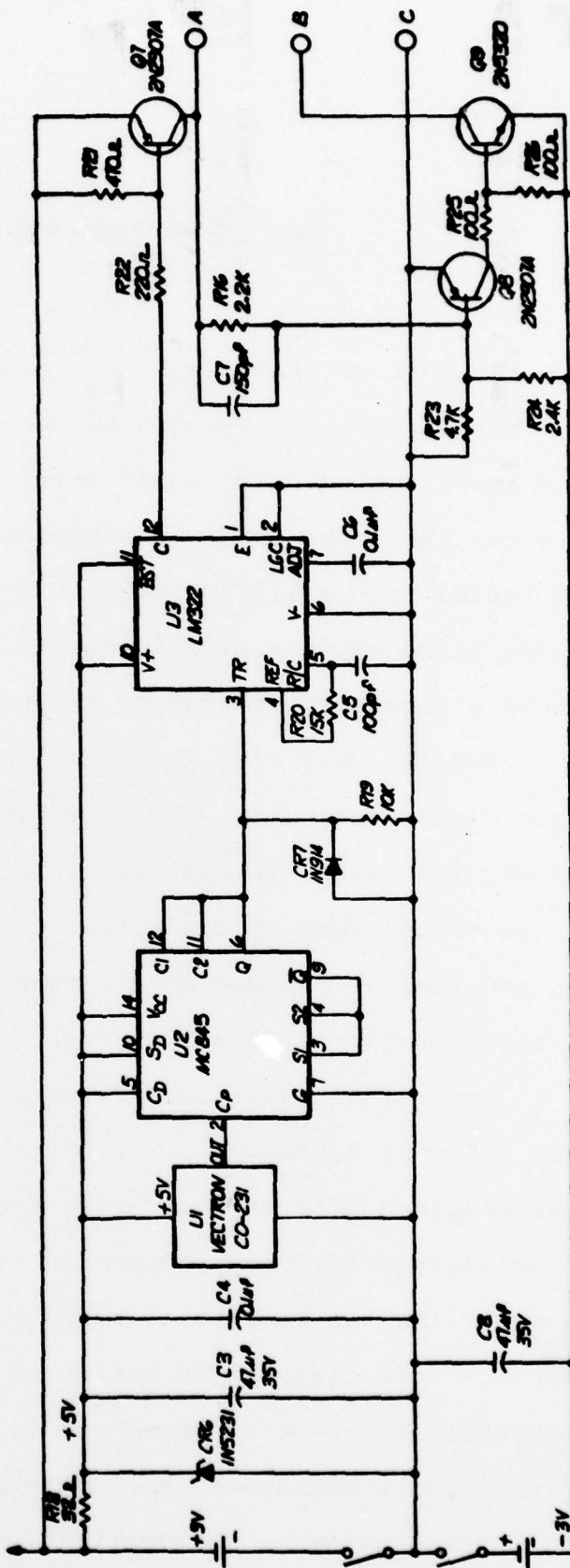
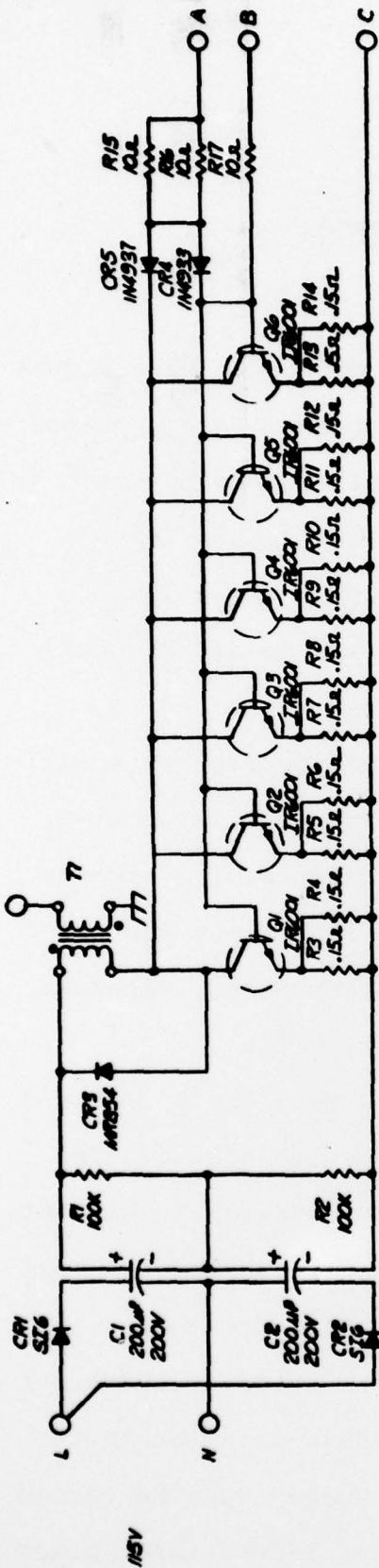

FIGURE 7
15 KV PULSE GENERATOR

pulse. Flip-flop U2 determines the output repetition rate of 5KHz by dividing the 10KHz clock pulse by two. Timer U3 generates an approximately 2 usec wide pulse at the 5KHz repetition frequency. Transistor Q7 provides base drive to turn the Darlington transistors on. Transistor Q9 provides negative drive to enhance turn off.

V. CONCLUSIONS

Based on breadboard tests of the Task A Pulse Generator at an intermediate level of 10kV, a practical approach has evolved to generate high voltage, high current nano-second pulses from a 28 volt input. At the 10kV level, a pulse current of 400A was measured through the 25 ohm load. Breadboard tests on the modulator at 30kV, when operated with a laboratory high voltage power supply, resulted in a pulse current of 1200A at a pulse width of 140ns. The pulse rise and fall time were approximately 40ns.

Breadboard tests on the SCR-magnetic modulator for the Task B Pulse Generator resulted in a 4kV, 40ns pulse into a 2Kohm load with a 28 volt input.

DISTRIBUTION LIST

- 12 Defense Documentation Center
ATTN: DDC-TCA
Cameron Station (Bldg 5)
Alexandria, VA 22314
- 1 Code R123, Tech Library
DCA Defense Comm Engrg Ctr
1860 Wiehle Ave
Reston, VA 22090
- 1 Defense Communications Agency
Technical Library Center
Code 205 (P.A. TOLOVI)
Washington, DC 20305
- 1 Office of Naval Research
Code 427
Arlington, VA 22217
- 1 Director
Naval Research Laboratory
ATTN: Code 2627
Washington, DC 20375
- 1 Commander
Naval Electronics Laboratory Center
ATTN: Library
San Diego, CA 92152
- 1 CDR, Naval Surface Weapons Center
White Oak Laboratory
ATTN: Library, Code WX-21
Silver Spring, MD 20910
- 1 Rome Air Development Center
ATTN: Documents Library (TILD)
Griffiss AFB, NY 13441
- 1 Hq, Air Force Systems Command
ATTN: DLCA
Andrews AFB
Washington, DC 20331
- 2 CDR, US Army Missile Command
Redstone Scientific Info Center
ATTN: Chief, Document Section
Redstone Arsenal, AL 35809

- 1 Commander
US Army Missile Command
ATTN: DRSMI-RE (Mr. Pittman)
Redstone Arsenal, AL 35809
- 3 Commandant
US Army Aviation Center
ATTN: ATZQ-D-MA
Fort Rucker, AL 36362
- 1 Director, Ballistic Missile Defense
Advanced Technology Center
ATTN: ATC-R, PO BOX 1500
Huntsville, AL 35807
- 1 Commander
HQ Fort Huachuca
ATTN: Technical Reference Div
Fort Huachuca, AZ 85613
- 2 Commander
US Army Electronic Proving Ground
ATTN: STEEP-MT
Fort Huachuca, AZ 85613
- 1 Commander
USASA Test & Evaluation Center
ATTN: IOA-CDR-T
Fort Huachuca, AZ 85613
- 1 Deputy for Science & Technology
Office, Assist Sec Army (R&D)
Washington, DC 20310
- 1 CDR, Harry Diamond Laboratories
ATTN: Library
2800 Powder Hill Road
Adelphi, MD 20783
- 1 Director
US Army Ballistic Research Labs
ATTN: DRXBR-LB
Aberdeen Proving Ground, MD 21005
- 1 Harry Diamond Laboratories, Dept of Army
ATTN: DRXDO-RCB (Dr. J. Nemarich)
2800 Powder Hill Road
Adelphi, MD 20783
- 1 Commander
US Army Tank-Automotive Command
ATTN: DRDTA-RH
Warren, MI 48090

- 1 CDR, US Army Aviation Systems Command
ATTN: DRSAV-G
PO Box 209
St. Louis, MO 63166
- 1 TRI-TAC Office
ATTN: CSS (Dr. Pritchard)
Fort Monmouth, NJ 07703
- 1 CDR, US Army Research Office
ATTN: DRXRO-IP
PO Box 12211
Research Triangle Park, NC 07709
- 1 CDR, US Army Research Office
ATTN: DRXRO-PH (Dr. R. J. Lontz)
PO Box 12211
Research Triangle Park, NC 27709
- 1 Commandant
US Army Air Defense School
ATTN: ATSA-CD-MC
Fort Bliss, TX 79916
- 1 Commander, DARCOM
ATTN: DRCDE
5001 Eisenhower Ave.
Alexandria, VA 22333
- 1 Chief
Ofc of Missile Electronic Warfare
Electronic Warfare Lab, ECOM
White Sands Missile Range, NM 88002

Commander
US Army Electronics Command
Fort Monmouth, NJ 07703

- 1 DRSEL-WL-D
- 3 DRSEL-CT-D
- 1 DRSEL-TL-DT
- 3 DRSEL-TL-BG
- 1 DRSEL-TL-BG (Ofc of Record)
- 2 DRSEL-MS-TI
- 1 DRSEL-TL-D
- 10 Originating Office

- 2 MIT - Lincoln Laboratory
ATTN: Library (RM A-082)
PO Box 73
Lexington, MA 02173
- 1 NASA Scientific & Tech Info Facility
Baltimore/Washington Intl Airport
PO Box 8757, MD 21240
- 2 Advisory Group on Electron Devices
201 Varick Street, 9th Floor
New York, NY 10014
- 1 Physics International
ATTN: Mr. B. Yen
2700 Mercer Street
San Leandro, California 94577
- 1 Fusion Industries, Inc.
ATTN: Mr. Vernon L. Smith
P.O. Box 31813
Dallas, Texas 75231