

AD-A066 852

NAVAL UNDERSEA WARFARE CENTER SAN DIEGO CALIF
DOPPLER MEASUREMENT CHARACTERISTICS OF BENDIX MONOPPLER, (U)
FEB 69 G A TURTON
NUWC-TN-233

F/G 17/1

UNCLASSIFIED

NL

1 OF 1
ADA
066852

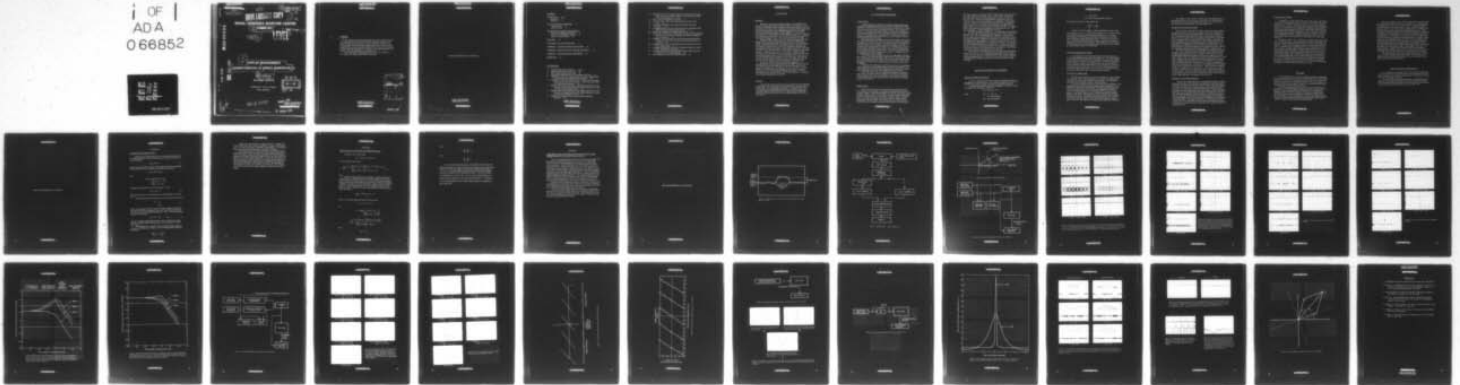

END
DATE
FILMED

6-79
DDC

UNCLASSIFIED

~~CONFIDENTIAL~~

GROUP 4

Downgraded at 3-year intervals.
declassified after 12 years.

Lili

(14)

NUWC-TN-233

COPY

14

①

SC

OOVI LIBRARY COPY

NAVAL UNDERSEA WARFARE CENTER

(11)

FEBRUARY 1969

I MOST Project - 3

(12) 37p.

LEVEL

#

000961

AD A0 66852

TN-233

DDC FILE COPY

⑥

**DOPPLER MEASUREMENT
CHARACTERISTICS OF BENDIX MONOPPLER (U)**

(10)

by G. A. Turton

San Diego, California

SUBPROJECT NO. SF 1010316

TASK NO. B132

DDC

RECEIVED
APR 4 1979

A

000961

9/10

403023

700515 (203)
UNCLASSIFIED
~~CONFIDENTIAL~~

ENCE (7) TO SHIPS SER OOVI-0172

LB 706915 (203)

FOREWORD

△ This technical note describes the Doppler measurement technique employed in the Monoppler FACT unit and some of the associated measurement artifacts. This note should not be construed as a complete performance evaluation or as a technical manual. This note has been prepared in the interest of others at NUWC and possibly a few persons or activities outside NUWC. It presents for information a small portion of the work being done in the area of sonar signal measurement and analysis. Only limited distribution is contemplated. ←

The author gratefully acknowledges the assistance of J.A. Nesheim, L.P. Mulcahy, R.H. Prager and R.E. White in this effort.

ACCESSION NO.	
HTH	White Section <input checked="" type="checkbox"/>
ODD	Diff Section <input type="checkbox"/>
UNANTHORIZED	<input type="checkbox"/>
<i>Put in file</i>	
BY	
DISTRIBUTION/AVAILABILITY CODES	
DISL	AVAIL. INFO. SPECIAL
A	

UNCLASSIFIED

~~CONFIDENTIAL~~

[Faint, illegible text, possibly bleed-through from the reverse side of the page]

THIS PAGE INTENTIONALLY LEFT BLANK



UNCLASSIFIED

~~CONFIDENTIAL~~

UNCLASSIFIED

~~CONFIDENTIAL~~

CONTENTS

INTRODUCTION . . . page 5
 Background . . . 5
 Objective . . . 5

FACT UNIT GENERAL DESCRIPTION . . . 6
 Display Features . . . 6
 Signal Processor . . . 6

INSTANTANEOUS FREQUENCY MEASUREMENT . . . 7
 Definition of Instantaneous Frequency . . . 7
 Phase Velocity Measurement Artifacts . . . 8
 Frequency Foldover Effects . . . 10

DISCUSSION . . . 10

CONCLUSIONS AND RECOMMENDATIONS . . . 11

APPENDIX A: ANALYSIS OF PHASE SLOPE FILTER . . . 13

APPENDIX B: PHASE VELOCITY OF TWO SINE WAVE INPUT . . . 15

APPENDIX C: MONOPPLER-DACIM I COMPARISON . . . 17

REFERENCES . . . 39

ILLUSTRATIONS

1 Simulated output trace of FACT unit . . . page 19

2 Simplified block diagram of FACT unit . . . 20

3 Phasor diagram for narrow band signal . . . 21

4 Experimental configuration for two sine component input tests . . . 21

5 Photographs of FACT unit output waveforms for two sine component input signal with amplitude and frequency as a parameter . . . 22

6 Photographs of FACT units output waveforms for a sine wave plus narrow-band noise input with sine wave frequency, signal-to-noise ratio, and noise bandwidth as parameters . . . 23-25

7 RMS fluctuation in FACT unit output versus signal-to-noise ratio for a sine wave plus narrow-band noise input with sine wave frequency as a parameter and a noise bandwidth of 10 Hz . . . 26

8 RMS fluctuation in FACT unit output versus signal-to-noise ratio for a sine wave plus narrow-band noise input with sine wave frequency as a parameter and a noise bandwidth of 40 Hz . . . 27

9 Experimental configuration for sine wave plus narrow-band noise input tests . . . 28

UNCLASSIFIED

~~CONFIDENTIAL~~

CONFIDENTIAL

- 10 Photographs of FACT unit output waveform for CW pulse plus narrow-band noise input with pulse length, frequency, noise bandwidth, and signal-to-noise ratio as parameters . . . 29-30
- 11 Phase shift versus frequency for delay line . . . 31
- 12 FACT unit output voltage versus input frequency for pure sine wave input . . . 32
- 13 Experimental configuration for measuring FACT output level versus frequency . . . 33
- 14 Photographs showing FACT unit output waveforms for a sinusoidally modulated FM input near frequency foldover points . . . 33
- 15 Experimental configuration for frequency foldover tests . . . 34
- 16 Relative phase velocity versus relative phase over one cycle of the difference frequency for a two sine wave component input signal with amplitude ratio as a parameter . . . 35
- 17 Photographs showing FACT unit and DACIM I output waveforms for 30 ms CW pulse plus narrow-band noise input with signal to noise ratio as a parameter . . . 36
- 18 Photographs show FACT unit and DACIM I output waveforms for a two sine wave component input . . . 37
- 19 Photograph showing FACT unit and DACIM I output waveforms for a sinusoidally modulated FM input signal . . . 37
- 20 Photograph showing FACT unit and DACIM I output waveform for a 30 ms CW pulse plus narrow-band input signal . . . 37
- 21 Phasor Diagram of two sine wave component signal . . . 38

CONFIDENTIAL

INTRODUCTION

Background

Monoppler is an acronym for Monopulse Doppler. The Monoppler FACT (Frequency Acquisition and Classification Technique) unit is a frequency measurement device constructed by Bendix corporation, Bendix Electrodynamics Division, North Hollywood, California. Work on Monoppler was started in 1961. In April, 1963, a sea test was performed with an engineering prototype using an AN/SQS-29 sonar with a transmission frequency of 8 kHz. Reference [1]* describes the results of that test. In 1964, BuShips Contract NOBSR-91331 was let for construction of an experimental Monoppler unit to be used with the AN/SQS-23 sonar which has a transmission frequency of 5 kHz. This unit was completed in July, 1965.

NUWC Code D606's (formerly NEL Code 3180) involvement with Monoppler began in 1963 when NEL provided Bendix Corporation with AN/SQS-10 and AN/SQS-11 sonar audio channel tape recordings of submarine and non-submarine contacts. After the contract for the new Monoppler was let in 1964, NEL acted as consultant to Bendix personnel on the final configuration of Monoppler and instrumentation necessary for laboratory experimentation with the unit. The Monoppler FACT unit was delivered to NEL in August, 1965 and underwent a preliminary evaluation. At that time, the FACT unit was designed to accept the 65 kHz audio signal of the AN/SQS-23 sonar as an input signal. In order to process 5 kHz simulated sonar signals a test set was delivered with the FACT unit to convert the 5 kHz simulated signals to 65 kHz for the FACT unit input. The preliminary evaluation indicated that the input dynamic range of the combination of test set and FACT unit was insufficient for the experimental work planned at NEL.

In February 1966 NEL contracted with Bendix Corporation (Control N123-(953)55823A to build a modified signal processor (MSP) input unit to accept 5 kHz data directly, thus eliminating the test set and increasing the dynamic range to an acceptable value. The modified FACT unit was completed in April, 1966 and sent to Defense Research Laboratory in Austin, Texas to undergo a simulated sea test in which recorded AN/SQS-23 sonar signals were employed. The results of that test are described in [2]. The FACT unit was then returned to NEL for further experimentation in June 1966.

Objectives

The objectives of this technical note are to describe some of the operating characteristics of the signal processor in the modified FACT unit and to indicate how they affect active sonar Doppler measurements. Although the FACT unit possesses many specialized display features, this note will be limited primarily to the input signal processing technique. The important display features are briefly discussed in the next section. For a complete description of the FACT unit, see [3].

CONFIDENTIAL

CONFIDENTIAL

FACT UNIT GENERAL DESCRIPTION

Display Features

In normal operation, the FACT unit is designed to measure target range rate from the Doppler frequency shift of echoes with a 30 millisecond CW transmitted pulse. The FACT unit consists of a frequency discriminator and a storage tube oscilloscope display with a set of special controls. The "instantaneous frequency" of a narrow-band sonar input signal is measured and displayed as an analog voltage waveform on the CRT. The horizontal sweep rate is adjustable to conform to the round trip time of a sonar pulse for 1 kiloyard and 5 kiloyards. A range-gated, expanded sweep of 500 milliseconds is also available for more detailed observation of detected echoes.

The vertical scale is calibrated in knots for direct reading of the range rate indicated by the frequency of the sonar echo. The scale sensitivity available to the operator are 1, 3 and 10 knots/cm. The target range rate is measured as the difference between target echo Doppler and own ship's Doppler. The latter is measured from the trace produced by reverberation. A sliding range rate scale is provided to allow adjustment of the zero know reference line for correspondence to the average level of the reverberation trace. This allows the operator to read the target range rate directly from the range rate scale. A simulated echo plus reverberation trace is shown in Figure 1.

If the operator wishes to observe an echo for a longer length of time than one sweep cycle, he can use the display storage mode to "hold" the trace indefinitely. Another storage mode which paints five consecutive expanded sweep echo returns on the tube can be used to observe the echo consistency. In this mode, the range-gated echo traces are vertically spaced one centimeter apart to avoid overlapping.

In addition to the CRT display, the FACT unit also has an instrumentation output equivalent to the discriminator output for laboratory measurements of the analog output signal. Using this output, simulated sonar echoes may be examined with an oscilloscope whose sweep can be triggered by the echo simulator.

The FACT unit has special record-playback connections for a magnetic tape recorder. This allows input sonar signals to be recorded and played back directly through the FACT unit. Wow and flutter control circuitry is provided to eliminate Doppler artifacts that might appear if the sonar signals were recorded external to the FACT unit.

Signal Processor

The FACT unit signal processor extracts Doppler information from the axis-crossings of the input signal. A simplified block diagram of the FACT unit is shown in Figure 2. After being heterodyned to 21 kHz, the input signal proceeds through two parallel channels. In one channel, the negative going axis-crossings (NGAC) are marked by pulses which are fed to one input of a phase comparator. In the second channel, the phase of the incoming signal is shifted in passing through phase slope filter (PSF). The positive going axis-crossings (PGAC) of the PSF output are then marked by pulses which are applied to the second input

CONFIDENTIAL

of the phase comparator. The phase shift in the PSF is linearly proportional to the input signal frequency deviation from 5 kHz. At 5 kHz there is no measurable phase shift and the output of the phase comparator is a square wave whose d.c. component is zero. When the input signal frequency deviates from 5 kHz, the square wave output of the phase comparator is nonsymmetrical, containing either a positive or negative d.c. component according to whether the input signal frequency is greater or less than 5 kHz. The d.c. component of the phase detector output is filtered out in a low pass filter and displayed on the CRT face. Doppler shifts in the signal frequency are displayed as vertical deflections on the CRT. The resulting trace is a graph of Doppler shift versus time.

The PSF is the heart of the FACT unit. It is equivalent to a distortionless delay line whose delay time is proportional to the slope of its phase shift versus frequency curve. This is shown analytically in Appendix A. This delay time places a lower limit on the length of the sonar pulse from which Monoppler can extract Doppler information. Operation with shorter pulses would require a shorter delay time with an accompanying loss in sensitivity. This can be looked at, also, by considering the target possibly as a set of discrete reflectors. If it is desired to resolve or measure the frequency of each reflector, it is necessary for the time delay to be at least less than the pulse length. Thus the frequency measurement is taken from two points on the waveform from the same reflector. The FACT unit currently has a delay time of approximately 2.4 milliseconds.

The construction of the PSF necessitates constraints in its operating frequency and power level. It has a bandwidth of approximately 4 kHz centered at 21 kHz. The input signal must be heterodyned from 5 kHz to 21 kHz to match the delay line operating frequency. The delay line is also heat sensitive so that an amplitude limiter is used at the input to prevent the delay line from becoming overloaded.

INSTANTANEOUS FREQUENCY MEASUREMENT

Definition of Instantaneous Frequency

It has been stated that the FACT unit measures instantaneous frequency and displays it as a function of time. The concept of instantaneous frequency and the FACT unit's ability to measure it will now be discussed in more detail.

Instantaneous frequency is most naturally applied in the analysis of narrow band signal will be defined to be of the form:

$$X(t) = \text{Real} [A(t) e^{j\theta(t)}]$$

where

$$\theta(t) = \omega_c t + \varphi(t) + \varphi_0$$

$$\omega_c = 2\pi \times \text{center frequency}$$

$$\varphi(t) = \text{Time varying phase}$$

CONFIDENTIAL

CONFIDENTIAL

ϕ_0 = Initial phase

$A(t)$ = Slowly varying amplitude coefficient

the instantaneous frequency is here defined to be:

$$f = \frac{d\theta}{dt} = \omega_c + \frac{d\phi}{dt}$$

Consider $X(t)$ as the real part of a complex rotating phasor whose instantaneous angular velocity is $\omega_c + \frac{d\phi}{dt}$ and whose amplitude is $A(t)$. An axis-crossing occurs whenever the phasor passes through the imaginary axis. See Figure 3. Measurement devices which measure the elapsed time between axis-crossings implicitly measure the approximate phase velocity. The FACT unit is such a device. As mentioned earlier, the positive and negative going axis-crossings are marked by pulses which are used to trigger a phase comparator. The time relationship between the pulses is measured, and any deviation from half of one period of the carrier frequency appears as a Doppler shift.

Phase Velocity Measurements Artifacts

It is possible even in very narrow-band signals for the phase velocity to be very erratic depending on the nature of the function $\phi(t)$. This erratic variation causes adverse effects in devices such as Monoppler as it causes large frequency excursion spikes or "glitches" to corrupt the display. These effects are present in narrow-band sonar signals and reverberation and could cause some difficulty both in establishing a zero Doppler reference from the reverberation trace and measuring the Doppler on a target echo. See [4] for a more complete discussion of these effects. Rapid phase variations can be observed in several types of laboratory generated input signals, three of which will be discussed here.

Two Sine Wave Component Input

The first type, consisting of two sine wave components, is easy to generate in the laboratory and to explain mathematically. It consists of the algebraic sum of two sine waves with variable amplitudes and frequencies. The experimental configuration used to generate this input is shown in Figure 4.

A derivation of the phase velocity is given both in [5] and Appendix B. The photographs shown in Figure 5 depict the Monoppler input and output for several combinations of frequencies and amplitudes. The frequency and amplitude of one sine wave are held constant while the frequency and amplitude of the other is varied. The constant frequency was set at 5 kHz, the FACT unit input center frequency. The variable frequency was set at 5080 Hz and 5040 Hz simulating frequency shifts from the center frequency equivalent to Doppler shifts of approximately 23 and 11 knots. The difference frequency appears as a beat variation on the amplitude of the input signal. It can be seen that the frequency excursion spikes on the FACT unit output are very similar to those predicted in Appendix B.

CONFIDENTIAL

The amplitude of these "glitches" depends both on the amplitude ratio and the frequency difference of the two sine wave components. The excursions for a given frequency are greatest for amplitude ratios near 0 dB. It can be seen that they can be greater in amplitude than the average Doppler shift.

Sine Wave Plus Narrow-Band Noise Input

The second type of input signal is similar to the two sine wave components input discussed above, except that one component consists of narrow-band noise centered at 5 kHz. Because of the random character of the noise, random perturbations are introduced into the FACT unit output. The photographs in Figure 6a show the FACT unit output for the input consisting of sine wave plus narrow-band noise. For signal-to-noise ratio near 0 dB the beating effect is clearly present. In these photographs, the noise bandwidth was 10 Hz. In Figure 6b the same data are displayed except that the noise bandwidth has been increased to 30 Hz. In Figure 6c the noise bandwidth has been still further increased to 250 Hz. As the noise bandwidth is increased, the regularity of the beating effect becomes obscured due to the increasing dominance of the random perturbations in phase velocity.

The effect of increasing the noise bandwidth is more graphically illustrated in Figures 7 and 8. Here the rms output of the FACT unit was measured and plotted against input signal-to-noise ratio. Each graph contains three curves corresponding to three different Doppler shifts of the sine wave component, 0, 40, and 80 Hz. In Figure 7, the noise bandwidth was 10 Hz and the hump around $S/N = 0$ dB clearly illustrates large rms variation in the FACT unit output due to the beating effect. It should be noted that this effect is not present when the sine wave frequency corresponds to the noise center frequency, i.e., there is no beating effect when there is no Doppler shift. In Figure 8 the noise bandwidth has been increased to 30 Hz and the characteristic hump around $S/N = 0$ dB is flattened in comparison to Figure 7. Comparing Figures 7 and 8, in the low S/N region, the noise fluctuation becomes greater as the noise bandwidth is increased, and the beating effect is more obscured. In practical operation, effects due to changing noise bandwidth are encountered after each ping as the reverberation dies away and the background attains a higher proportion of wide-band sea and system noise.

CW Pulse Plus Narrow-Band Noise Input

The third type of input signal that was investigated consisted of a CW pulse plus narrow-band noise. The experimental configuration used to generate signals of this type in the laboratory is shown in Figure 9. Figures 10a and 10b illustrate the FACT unit responses to these signals for several values of Doppler shift and S/N ratios. Two pulse lengths, 100 and 30 milliseconds are shown. The noise bandwidths are inversely proportional to the pulse lengths to simulate reverberation produced by active sonar transmitted pulses of the same length in the ocean medium. The same beating effects can be observed as in the continuous signals for S/N ratios near 0 dB. Similarly the effect is more pronounced in the 100 millisecond pulse lengths than in the 30 millisecond pulse lengths due to the difference in noise bandwidths. As the signal-to-noise ratio is increased beyond 6 dB, the ping trace loses most of the phase excursions except at the beginning and end of the pulse when the change from noise to signal plus noise is often accompanied by a rapid phase shift.

CONFIDENTIAL

CONFIDENTIAL

Frequency Foldover Effects

In Appendix A it is shown analytically that the phase shift versus frequency curve for the PSF should appear as shown in Figure 11. The steady state voltage output of the FACT unit was measured for a pure sine wave input and plotted against frequency in Figure 12. The experimental measurement setup is diagrammed in Figure 13. The theoretical curve extends over the frequency range from zero to infinity, but the bandlimiting filters in the FACT unit limit the measured frequency range to approximately 1000 Hz on either side of 5 kHz. Otherwise, in agreement over the measurement bandwidth. The shape of both plots resembles a sawtooth wave, forming ambiguity points in frequency determination. That is, for a given output voltage, there exist several frequencies which might represent the input frequency.

The effects of this frequency foldover on a sinusoidally modulated FM input signal is shown in Figure 14. These photographs were taken of the Monoppler output when a voltage controlled oscillator was used as an input voltage source (see Figure 15). In Figure 14a, the modulation frequency was 10 Hz and the frequency swing was ± 200 Hz around a center frequency of 5 kHz. In Figure 14b, the frequency swing was increased slightly so that the instantaneous frequency crossed the first foldover point near 5200 Hz. In Figure 14c, the frequency swing was increased again slightly so that the instantaneous frequency also crossed over the lower frequency foldover point. This frequency foldover effect is not important when measuring Doppler with a CW pulse since the frequency shift necessary to cross over the first foldover point is equivalent to approximately 70 knots range rate. However, if the FACT unit were to be used as a frequency discriminator for FM ramp or rooftop sonar pulses with frequency swings of a few hundred Hertz, the foldover over effect would have to be taken into account.

DISCUSSION

At the beginning of this note, most of the display features of the Monoppler FACT unit were briefly described in order to familiarize the reader with the external aspects of the FACT unit. No attempt has been made in this note to evaluate the FACT unit on the basis of its man-machine interface. This is more properly in the domain of human factors investigators. However, some of the obvious difficulties the operator may encounter will be discussed here.

It has been shown that the FACT unit uses time intervals between axis-crossings as its basic measurement and therefore its output is directly related to the phase velocity of the input signals. See Appendix C for a comparison of Monoppler output with DACIM I, a digital axis crossing time measuring device. The FACT system does not measure frequency components as would a bank of narrow band filters. It has been shown that even in narrow band signals, the phase velocity can fluctuate rapidly producing large spurious frequency shift spikes or "glitches" in phase velocity meters such as the FACT unit.

CONFIDENTIAL

What is the significance of these phase fluctuations to the sonar operator? The actual thickness of the CRT trace is approximately 0.1 cm. The most sensitive Doppler scale is 1.0 knot/cm. Therefore it may be said that the Doppler resolution of the FACT unit is approximately 0.1 knot. However, the operator, in order to position the scale cursor over the reverberation trace to establish a zero range rate reference, must average out the phase fluctuations by eye. Further investigation is needed to determine how accurately the average sonar operator can accomplish this. The beating effect can occur when a weak echo is received in strong reverberation. The frequency of the beating depends on the Doppler shift. For large Doppler shifts, the beating would appear as several "glitches" present in the echo. For small Doppler shifts, only one beat may occur during the echo duration making the effect practically noticeable. It is also possible that the echo itself might contain several rapid phase shifts due to interaction among several discrete components with slightly different Doppler shifts. This, for example, might occur when a submarine target is turning rapidly or when wake component is present. It appears that the operator would have to be trained to accommodate these and many other situations in order to effectively utilize the FACT unit. Here again there is need for a more detailed human factors study.

The frequency foldover effects are not significant unless the FACT unit is to be used with wideband FM transmitted signals. If this were the case, it might be necessary to redesign the phase slope filter to accommodate the wide frequency swings present in these signals.

CONCLUSIONS AND RECOMMENDATIONS

As a research tool, the Monopler FACT unit has limited usefulness due to its fixed center frequency, frequency foldover effects and specialized analog display. Individual wave period measurement devices are more suited to this purpose swing to their greater flexibility.

As for the FACT unit operational capabilities, a thorough human factors evaluation is recommended with trained sonar operators and actual sea data in order to determine attainable performance levels and amount of training necessary to achieve them, especially for signal to noise ratios below 6 dB.

CONFIDENTIAL

CONFIDENTIAL

[Faint, illegible text, likely bleed-through from the reverse side of the page.]

THIS PAGE INTENTIONALLY LEFT BLANK

[Faint, illegible text, likely bleed-through from the reverse side of the page.]

CONFIDENTIAL

CONFIDENTIAL

APPENDIX A

ANALYSIS OF PHASE SLOPE FILTER

Mathematically, the phase slope filter is a distortionless delay line over limited frequency range. Over this frequency range, the frequency transfer function can be written

$$H(j\omega) = Ke^{-j\omega\alpha} \quad (1)$$

where K and α are constants. See [7]. Given an input $f(t)$ and its corresponding frequency transform $F(j\omega)$, the transform of the output can be written

$$G(j\omega) = H(j\omega) F(j\omega)$$

then

$$\begin{aligned} G(j\omega) &= Ke^{-j\omega\alpha} \int f(x) e^{-j\omega x} dx \\ &= K \int f(x) e^{-j\omega(x + \alpha)} dx \\ &= K \int f(t - \alpha) e^{-j\omega t} dt \end{aligned}$$

taking the inverse transform to recover the output $g(t)$ we have

$$g(t) = K f(t - \alpha) \quad (2)$$

The output is therefore just the input delayed by α and multiplied by a scale factor K.

The phase shift through a distortionless delay line is given by the expression

$$\begin{aligned} \Delta\phi &= \alpha\omega_c \\ &= \alpha 2\pi f \end{aligned} \quad (3)$$

where f is the frequency in Hertz. However, the phase comparator in the FACT unit measures the relative phase between the input and output of the delay line, and it can only detect phase differences between $-\pi$ and $+\pi$. The observed phase shift $\Delta\phi'$ can be expressed

$$\Delta\phi' = \alpha 2\pi f - 2\pi n \quad \pi < \Delta\phi' < \pi \quad (4)$$

where n is an integer constrained by the limits on $\Delta\phi'$. If the delay α is fixed, there are an infinite number of combinations of n and f for which $\Delta\phi'$ is within these limits.

Corresponding to each value of n , there is a unique frequency range for which $\Delta\phi'$ satisfies the above conditions. The n^{th} frequency range is defined by the relation

$$\frac{2n-1}{2\alpha} < f_n < \frac{2n+1}{2\alpha}$$

CONFIDENTIAL

CONFIDENTIAL

A graph of $\Delta\phi'$ versus frequency is plotted in Figure 11. It appears as a series of linear ramps where each ramp corresponds to a frequency range defined by (5). The slope of each ramp is proportional to the parameter α . The longer the delay time, the more sensitive the output is to changes in frequency.

In the design of the FACT unit, the delay time α was judiciously chosen to give the maximum allowable sensitivity under the constraints that the ramp extend over the frequency range necessary to accommodate the maximum expected Doppler values and that the ramp pass through the point of zero phase shift for the shift for the zero Doppler signal input frequency. A plot of the FACT output voltage versus frequency is shown in Figure 12. It displays the same modular ramp behavior as described above. The vertical axis corresponds to the voltage normally applied to the vertical deflection plate of the CRT. The horizontal axis corresponds to the frequency of an input sine wave test signal. This voltage accurately reflects the state of the phase comparator for constant frequency input signals.

CONFIDENTIAL

APPENDIX B

PHASE VELOCITY IN TWO SINE WAVE COMPONENT SIGNAL

The phase velocity of the signal:

$$x(t) = A_1 \sin \omega_1 t + A_2 \sin \omega_2 t$$

can be expressed by the equation:

$$\frac{d\theta}{dt} = \frac{(\omega_1 - \omega_2) \left[\cos^2(\omega_1 - \omega_2)t + \frac{A_2}{A_1} \cos(\omega_1 - \omega_2)t + \sin^2(\omega_1 - \omega_2)t \right]}{\left[\frac{A_2}{A_1} + \cos(\omega_1 - \omega_2)t \right]^2 + \sin^2(\omega_1 - \omega_2)t} + \omega_2$$

Proof:

Consider the phasor diagram shown in Figure 21. Suppose that phasor \underline{A}_2 is fixed relative to a coordinate system rotating with angular velocity ω_2 . The phasor \underline{A}_1 rotates with angular velocity $\omega_1 - \omega_2$ relative to the moving coordinates. The true phase velocity of any phasor equals the velocity computed in the moving coordinate system plus the velocity of the moving coordinate system. The phase velocity θ of the resultant phasor \underline{B} will now be computed using this principle. Within the rotating coordinate system the resultant phasor \underline{B} is related to \underline{A}_1 and A_2 by the law of Sines:

$$\frac{\sin \theta'}{A_1} = \frac{\sin [(\omega_1 - \omega_2)t - \theta']}{A_2}$$

where θ' is the relative phase and is defined by the equation:

$$\theta' = \theta - \omega_2 t = (\omega_1 - \omega_2)t$$

Now,

$$\theta' = \arctan \left\{ \frac{\sin(\omega_1 - \omega_2)t}{\left[\frac{A_2}{A_1} + \cos(\omega_1 - \omega_2)t \right]} \right\}$$

$$\frac{d\theta'}{dt} = \frac{\Delta\omega \left[\cos^2 \Delta\omega t + \frac{B}{A} \cos \Delta\omega t + \sin^2 \Delta\omega t \right]}{\left[\frac{A_2}{A_1} + \cos \Delta\omega t \right]^2 + \sin \Delta\omega t}$$

where

$$\Delta\omega = \omega_1 - \omega_2$$

CONFIDENTIAL

CONFIDENTIAL

Since

$$\frac{d\theta'}{dt} = \frac{d\theta}{dt} - \omega_2$$

then

$$\frac{d\theta}{dt} = \frac{d\theta'}{dt} + \omega_2$$

It can be seen that the relative phase velocity $\frac{d\theta'}{dt}$ is a function only of the difference frequency $\Delta\omega$. Figure 16 shows the relative phase velocity plotted versus relative phase. The relative phase velocity scale is normalized with respect to $\Delta\omega = \omega_1 - \omega_2$. The relative phase scale extends from 0 to 2π so that the graph represents one complete cycle of the difference frequency. The two curves shown were computed for two values of $\frac{A_2}{A_1}$. It can be seen that as $\frac{A_2}{A_1}$ approaches one, the phase velocity approaches $\Delta\omega/2$ except at the point near $\theta' = \pi$. In the limiting case as $\frac{A_2}{A_1}$ approaches one, the resultant phasor undergoes an instantaneous phase shift of 180° .

CONFIDENTIAL

APPENDIX C

COMPARISON OF THE MONOPPLER FACT UNIT WITH A DIGITAL AXIS-CROSSING INTERVAL MEASUREMENT DEVICE (DACIM).

It has been stated throughout the body of this note that the Monoppler FACT unit extracts its information from the zero crossing times of the input signal. Figures 17-20 show several photographs taken to show the similarities that exist in the outputs of the FACT unit and in the DACIM I Digital axis crossing measurement device. DACIM I is described in [6]. The output of DACIM I is a series of pulses whose amplitudes correspond to the zero crossing times of individual cycles of the input signal. These pulses appear as dots in the photographs of oscilloscope traces illustrating the DACIM outputs. It should be noted that the DACIM display shows the input signal period versus time whereas the FACT unit displays instantaneous frequency versus time. The outputs are therefore inverted relative to each other. The chief difference between the FACT and DACIM processor is that the DACIM processes each cycle individually whereas the FACT unit sums over a running window of several cycles in order to gain sensitivity.

The FACT unit also incorporates extensive smoothing in its output whereas the DACIM unit has a discrete time output. However, the pulse output of DACIM can be smoothed using a simple RC time constant network to produce a trace which is very similar to the FACT output as shown in Figure 20.

As a research tool the DACIM type processor possesses more flexibility than the FACT unit in that its digital output can be utilized in a computer to perform any type of numerical calculation on the data. The DACIM system does not have a fixed operating frequency and therefore can operate on a much wider range of signals, including FM modulated inputs.

CONFIDENTIAL

CONFIDENTIAL

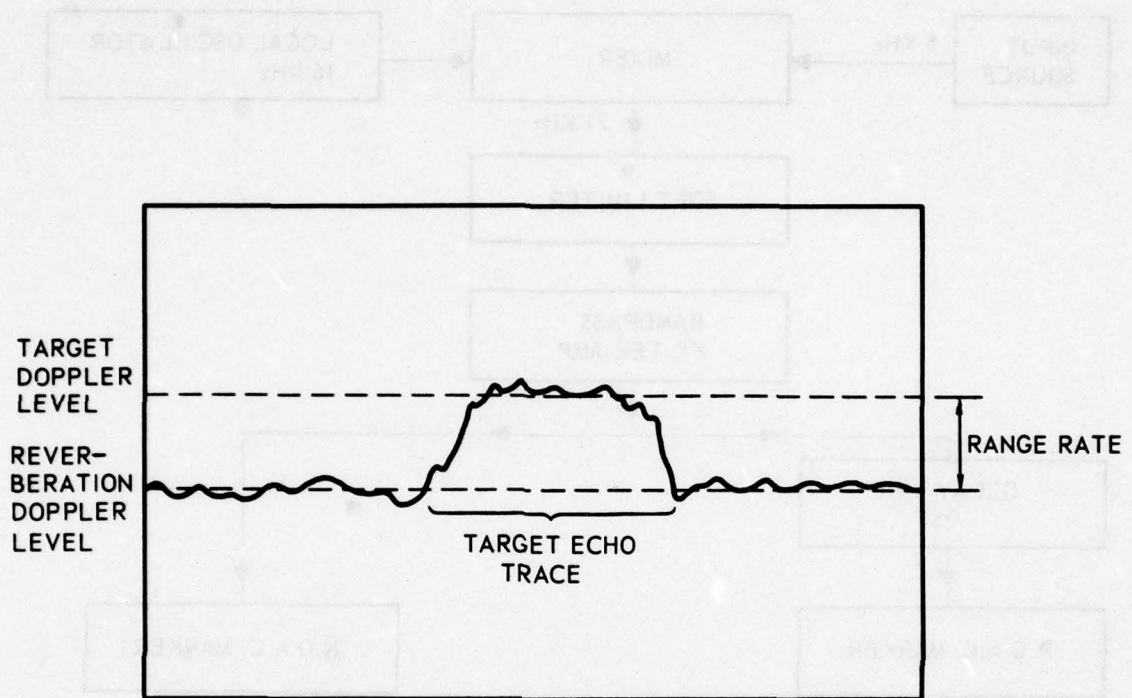

Figure 1. Simulated output trace of FACT unit showing the target echo and re-
verberation region.

CONFIDENTIAL

CONFIDENTIAL

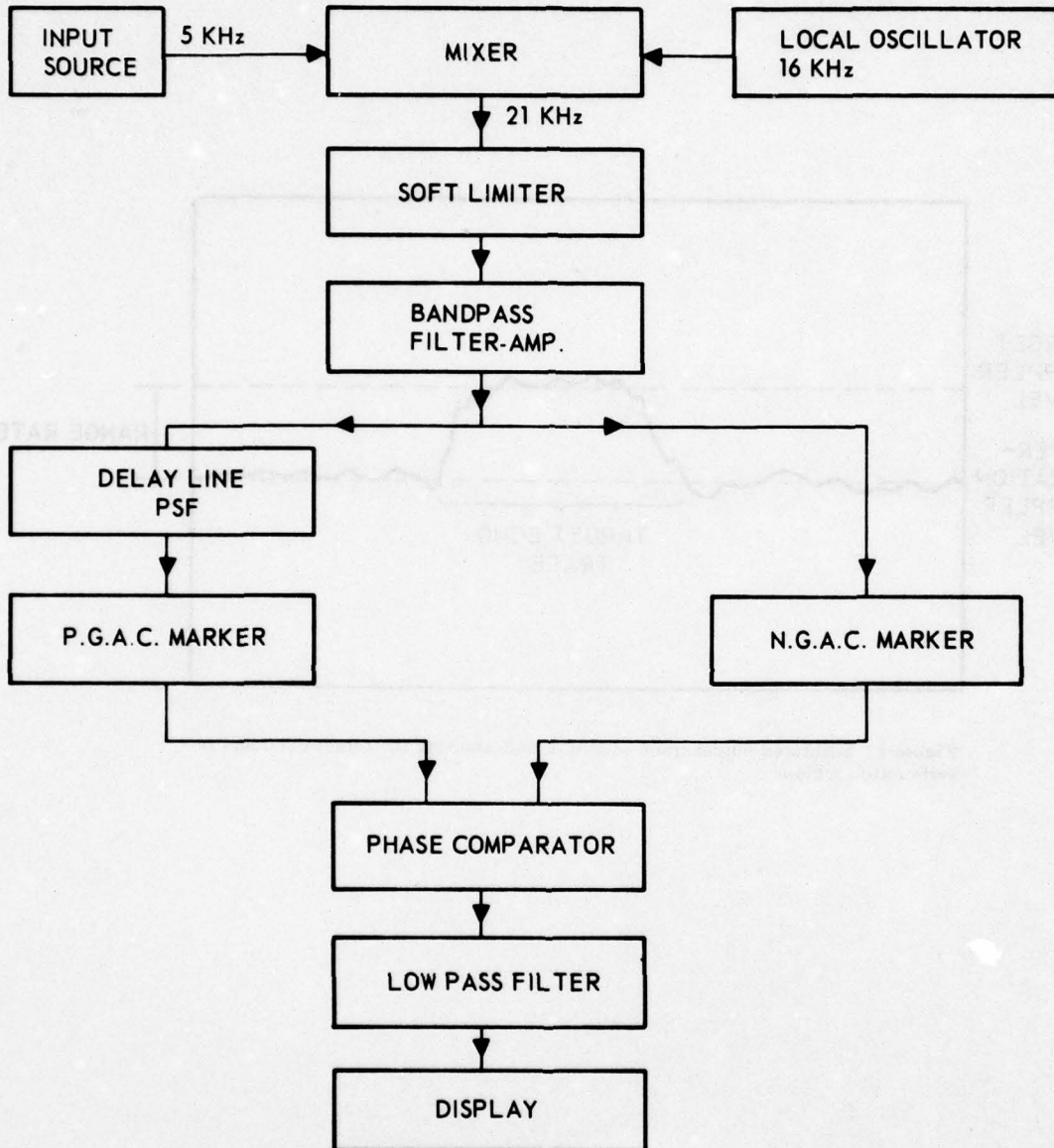

Figure 2. Simplified block diagram of FACT unit.

CONFIDENTIAL

CONFIDENTIAL

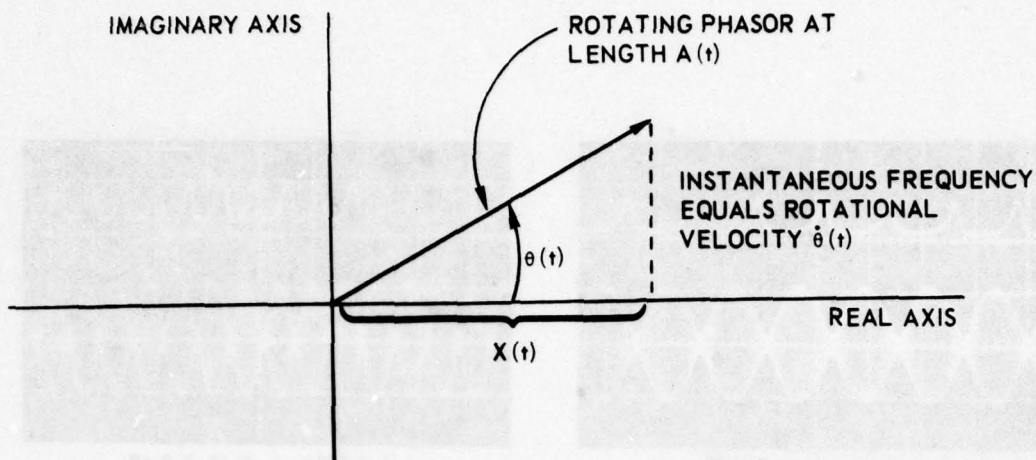

Figure 3. Phasor diagram for narrow-band signal.

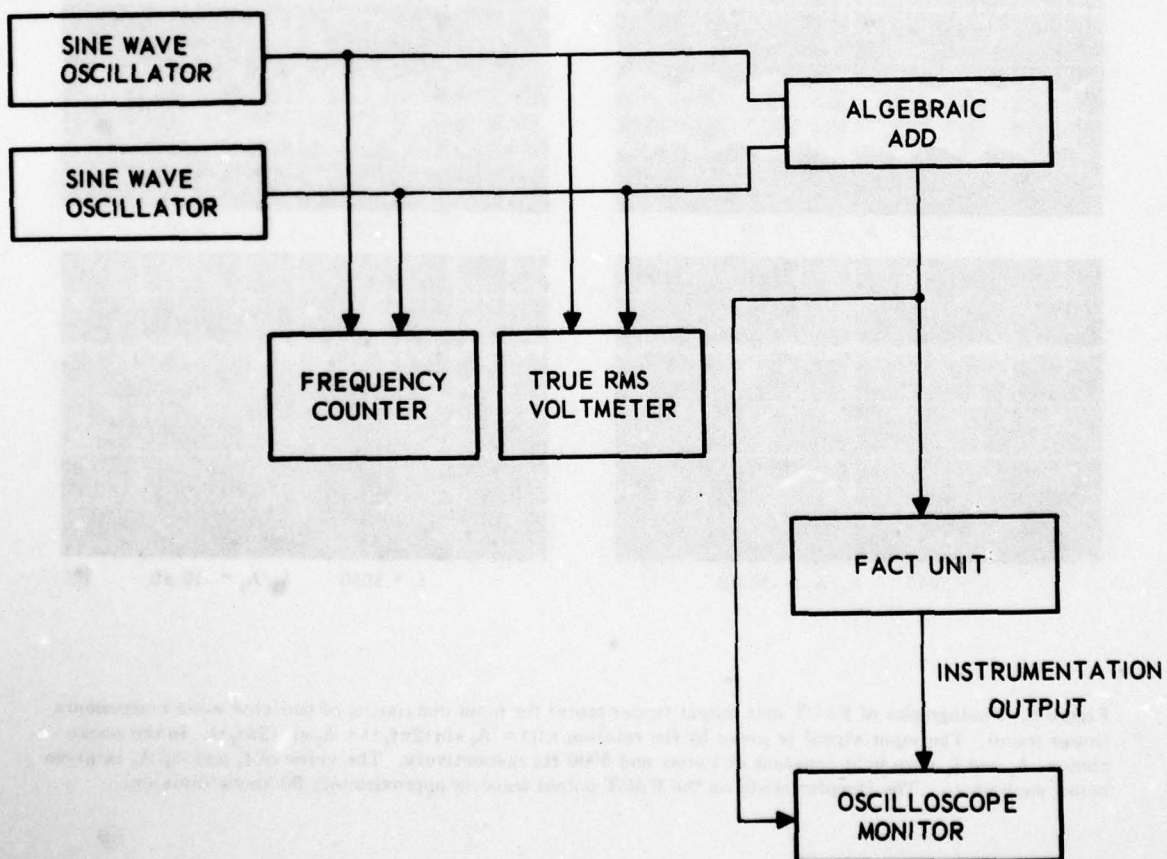

Figure 4. Experimental configuration for two sine wave input tests.

CONFIDENTIAL

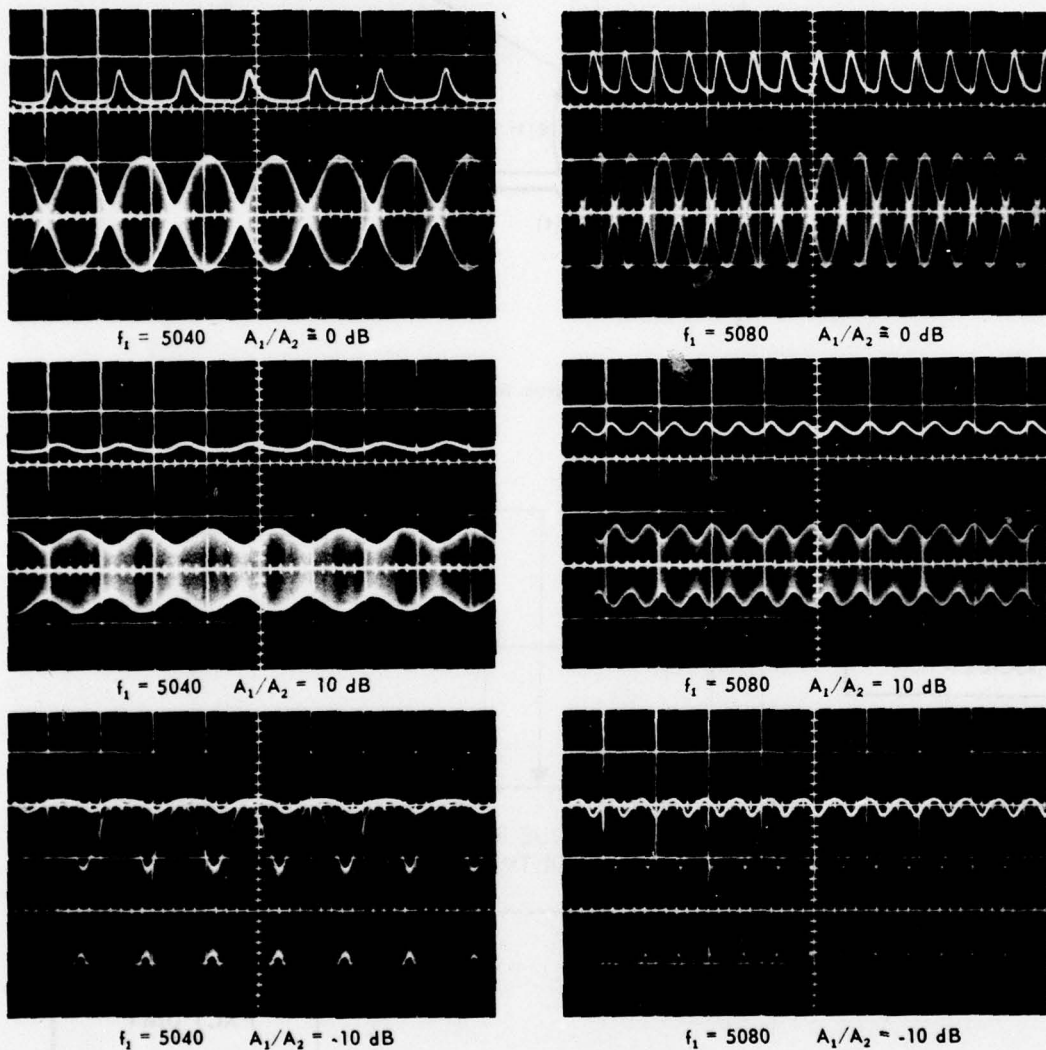
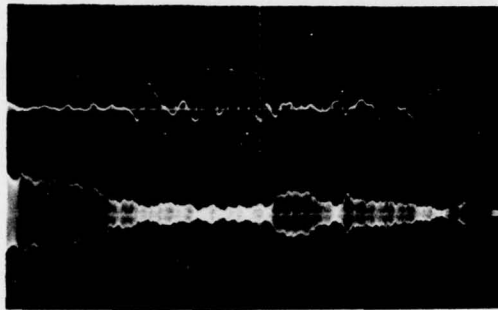
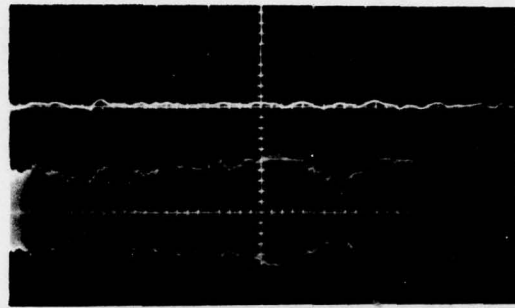

Figure 5. Photographs of FACT unit output (upper trace) for input consisting of two sine wave components (lower trace). The input signal is given by the relation $x(t) = A_1 \sin(2\pi f_1 t) + A_2 \sin(2\pi f_2 t)$. In the above photos, A_2 and f_2 were held constant at 1 vrms and 5000 Hz respectively. The value of f_1 and A_1/A_2 is given below each photo. The Doppler scale on the FACT output trace is approximately 50 knots/division.

CONFIDENTIAL



f = 5000 S/N = 0 dB



f = 5000 S/N = 10 dB

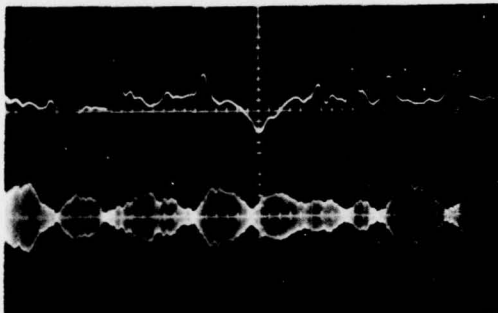

f = 5035 S/N = 0 dB

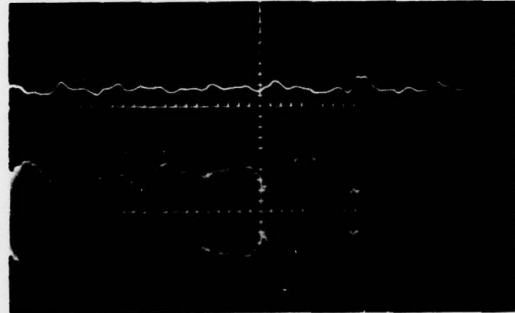

f = 5035 S/N = 10 dB

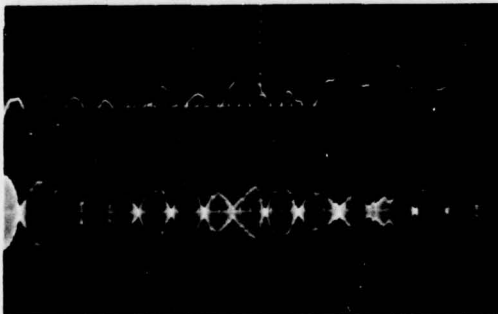

f = 5070 S/N = 0 dB

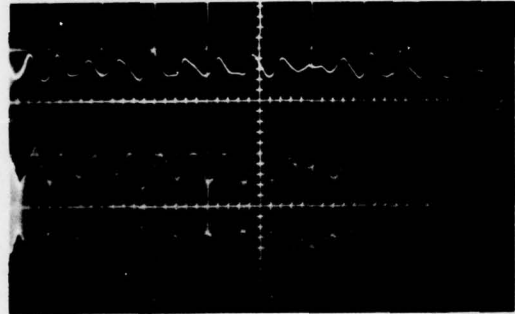

f = 5070 S/N = 10 dB

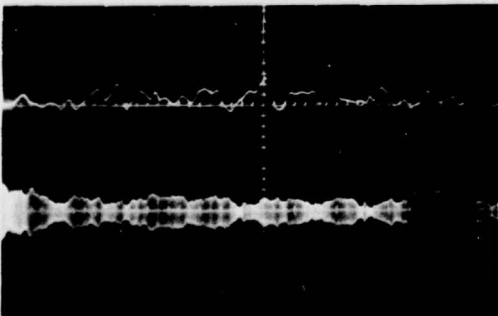

NOISE ALONE

Figure 6a. Photographs of oscilloscope traces of FACT unit input (lower trace) and output (upper trace) where the input consists of a continuous sine wave plus narrow band noise. The signal-to-noise ratio and sine wave frequency is given below each trace. The noise is centered at 5 KHz and has a bandwidth of 10 Hz. The Doppler scale on the FACT output trace is approximately 50 knots/division.

CONFIDENTIAL

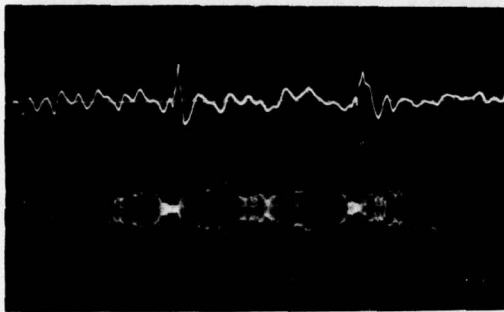

f = 5000 S/N = 0 dB

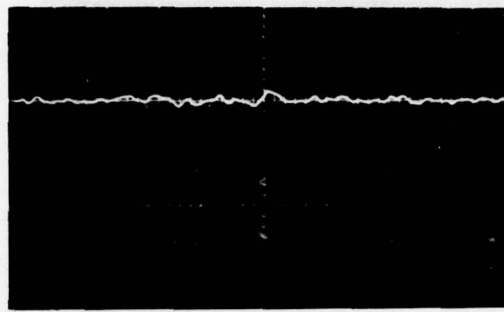

f = 5000 S/N = 10 dB

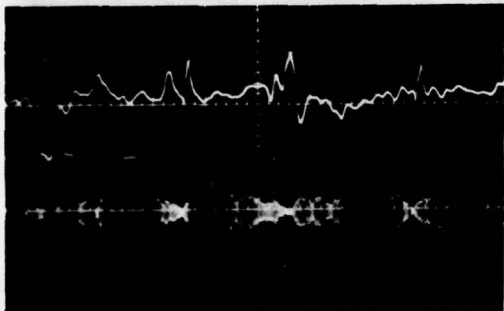

f = 5035 S/N = 0 dB

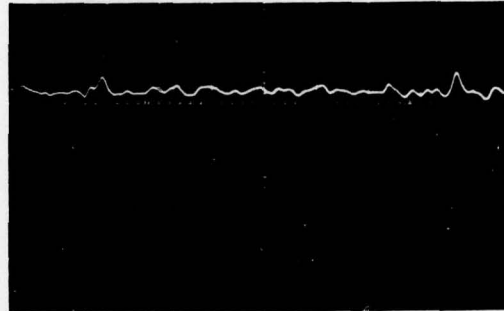

f = 5035 S/N = 10 dB

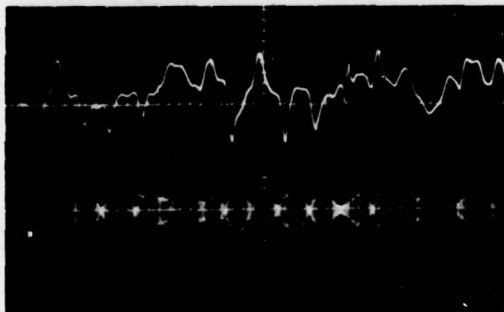

f = 5070 S/N = 0 dB

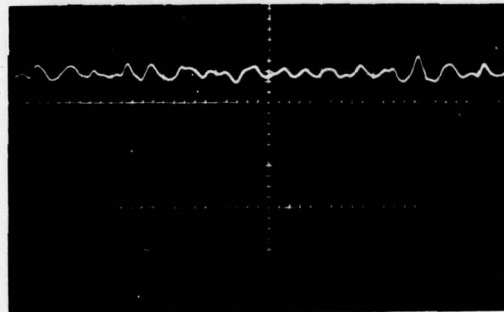

f = 5070 S/N = 10 dB

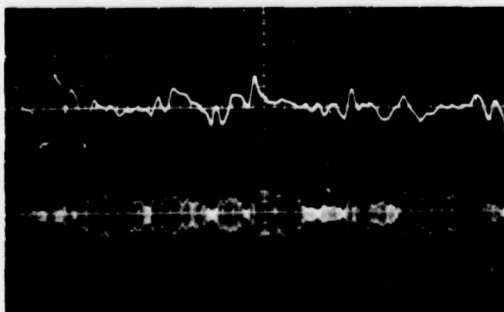

NOISE ALONE

Figure 6b. Same as 6a except that the noise bandwidth is 35 Hz.

CONFIDENTIAL

CONFIDENTIAL

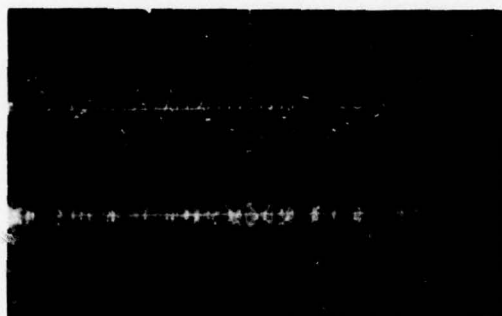

f = 5000 S/N = 0 dB

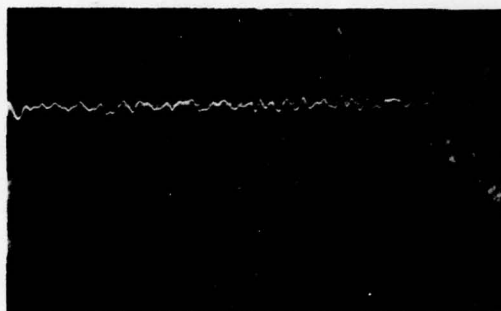

f = 5000 S/N = 10 dB

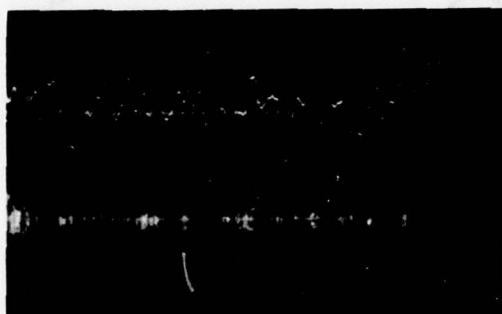

f = 5035 S/N = 0 dB

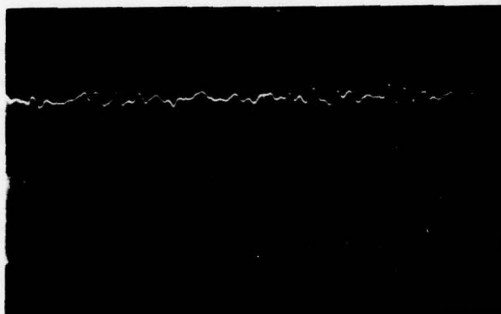

f = 5035 S/N = 10 dB



f = 5070 S/N = 0 dB

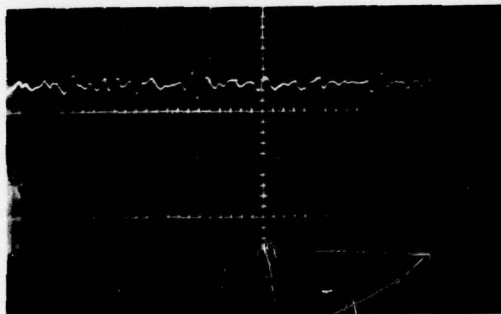

f = 5070 S/N = 10 dB



NOISE ALONE

Figure 6c. Same as 6a except that the noise bandwidth is 250 Hz.

CONFIDENTIAL

CONFIDENTIAL

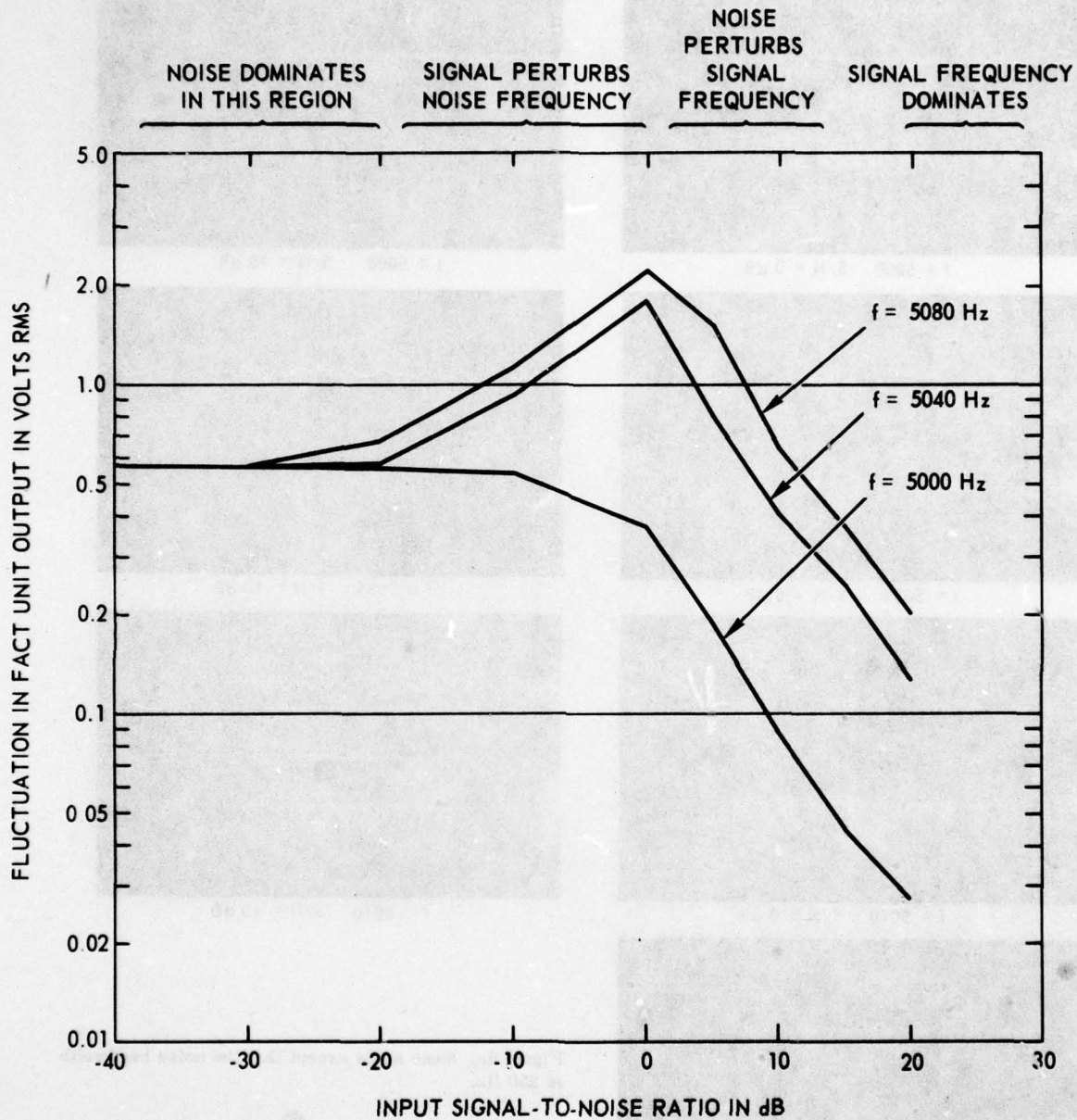

Figure 7. RMS fluctuation in FACT unit output vs input signal to noise ratio for an input consisting of a pure sine wave signal plus narrow band noise. The noise bandwidth is 10 Hz centered at 5 KHz and the noise amplitude is 0.2 vrms. One volt rms fluctuation in the FACT output is approximately equivalent to 17 knots rms fluctuation. The sine wave frequency for each curve is indicated.

CONFIDENTIAL

CONFIDENTIAL

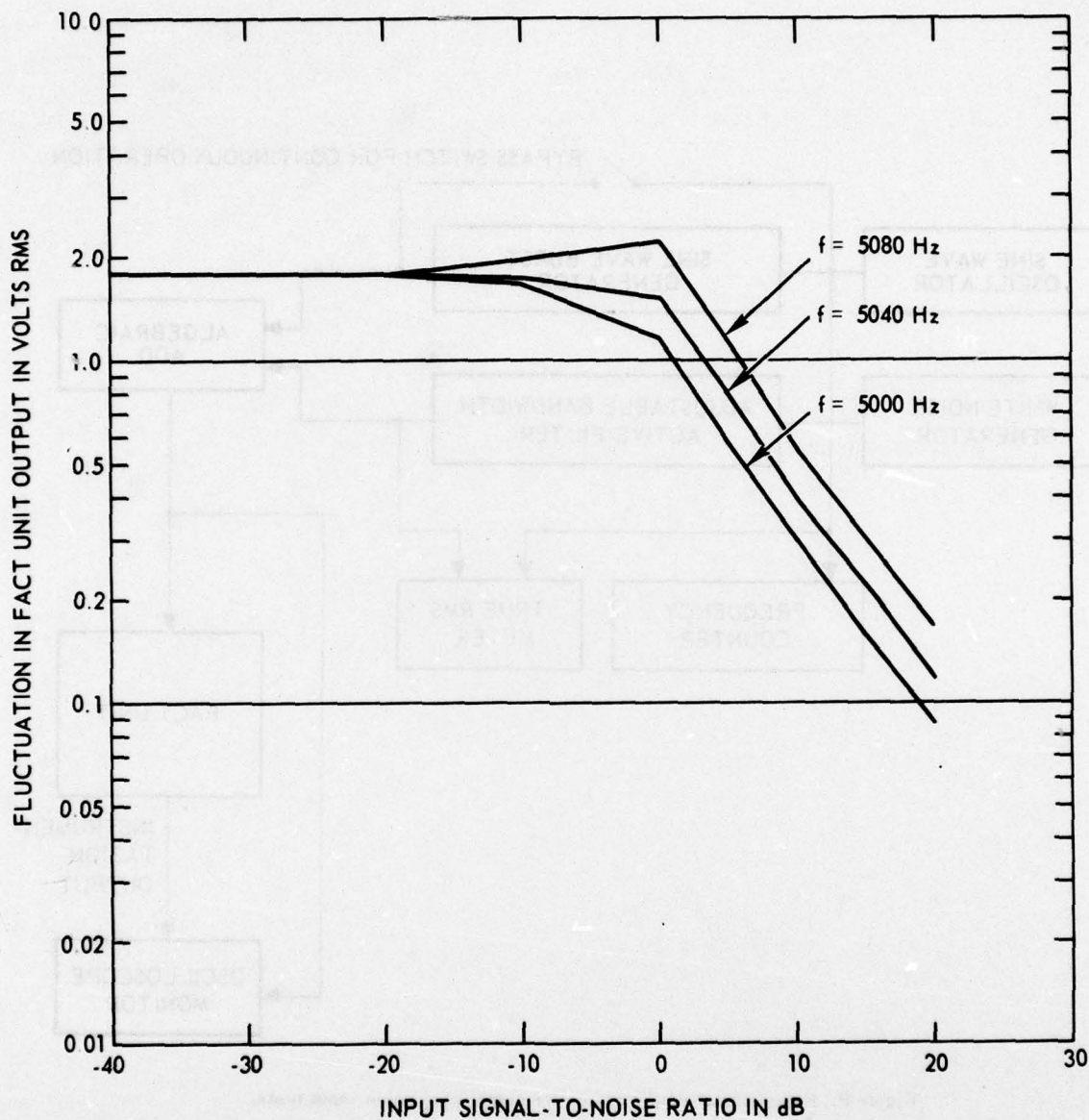

Figure 8. Rms fluctuation in FACT unit output vs signal-to-noise ratio for an input consisting of a pure sine wave plus narrow band noise. The noise bandwidth is 40 Hz centered at 5 KHz, and the noise amplitude is 0.2 vrms. One volt rms fluctuation is approximately equivalent to 17 knots rms fluctuation. The sine wave frequency for each curve is indicated.

CONFIDENTIAL

CONFIDENTIAL

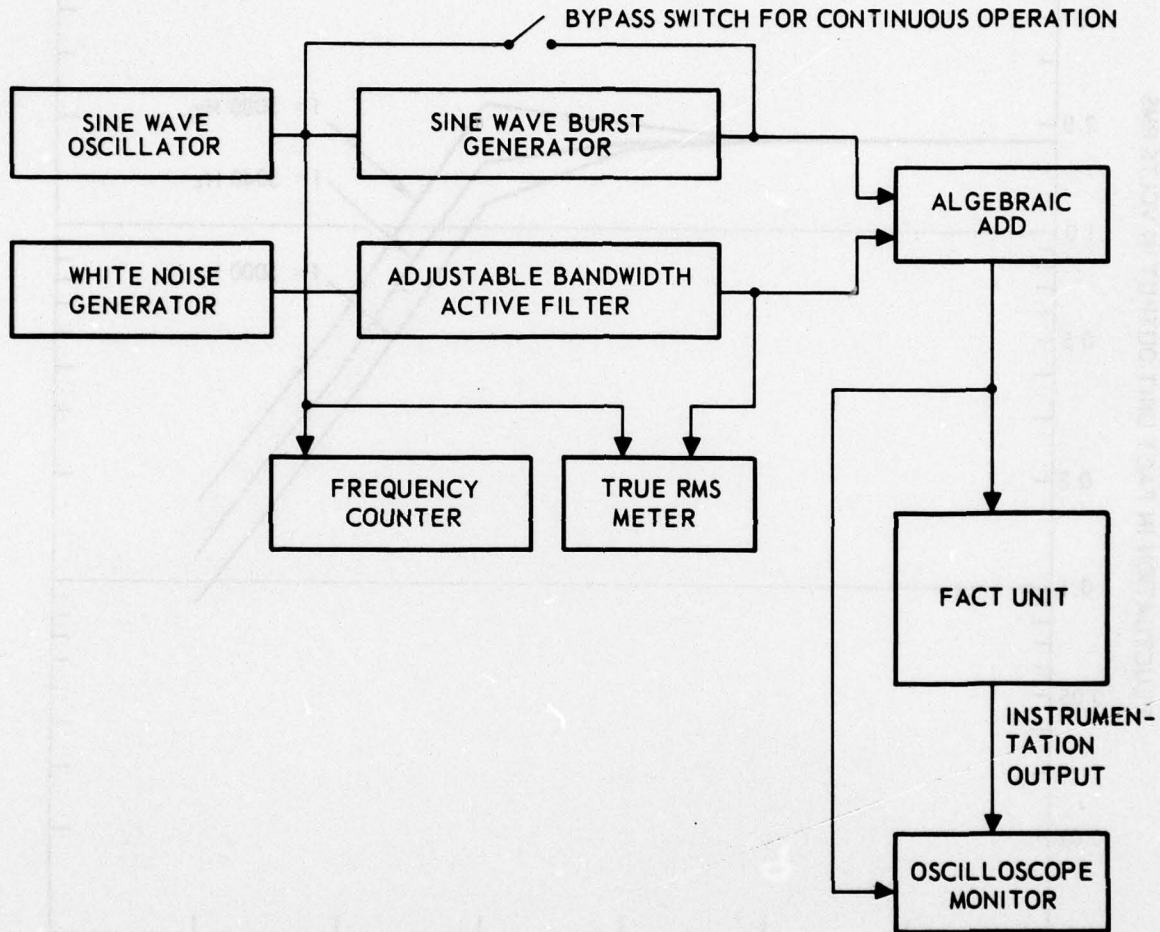

Figure 9. Experimental configuration for signal plus noise input tests.

CONFIDENTIAL

CONFIDENTIAL

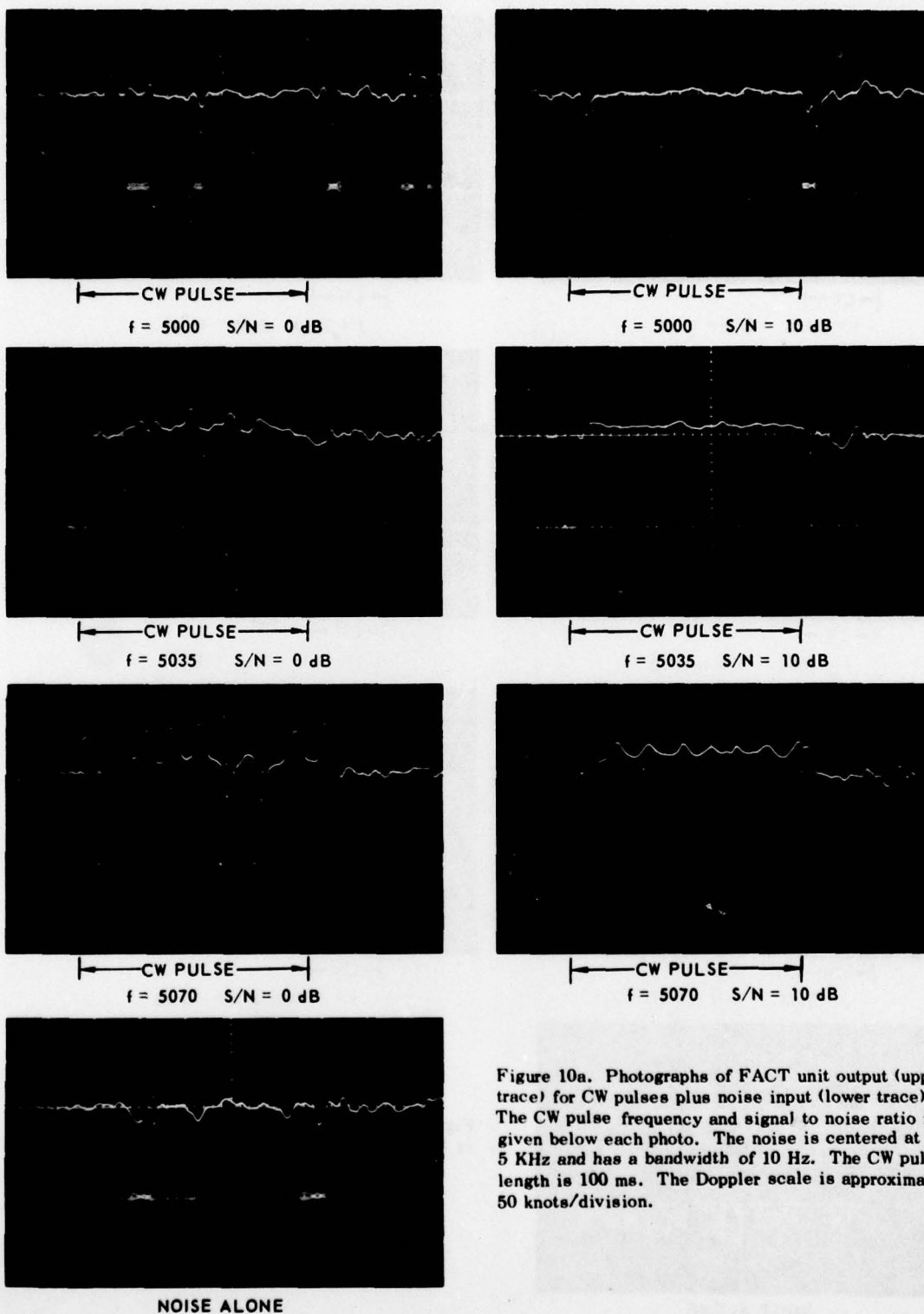
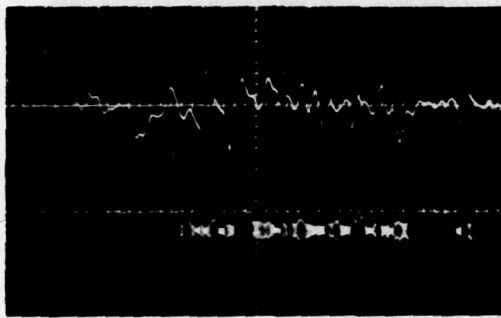
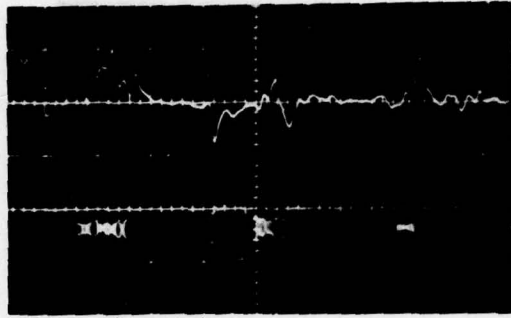

Figure 10a. Photographs of FACT unit output (upper trace) for CW pulses plus noise input (lower trace). The CW pulse frequency and signal to noise ratio is given below each photo. The noise is centered at 5 KHz and has a bandwidth of 10 Hz. The CW pulse length is 100 ms. The Doppler scale is approximately 50 knots/division.



← CW →
f = 5000 S/N = 0 dB



← CW →
f = 5000 S/N = 10 dB

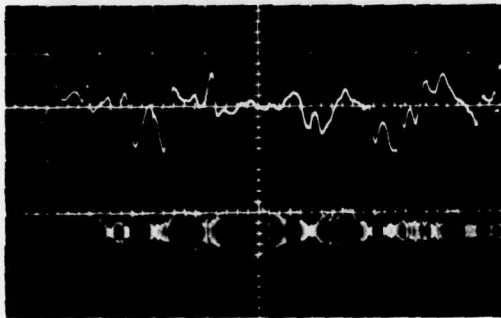

← CW →
f = 5035 S/N = 0 dB

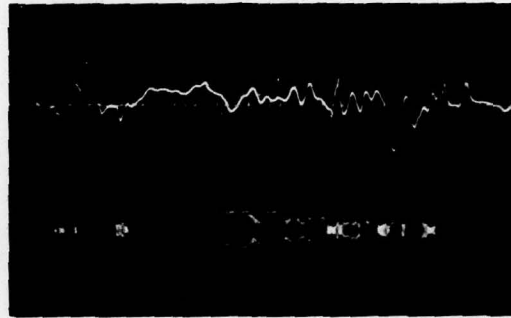

← CW →
f = 5035 S/N = 10 dB

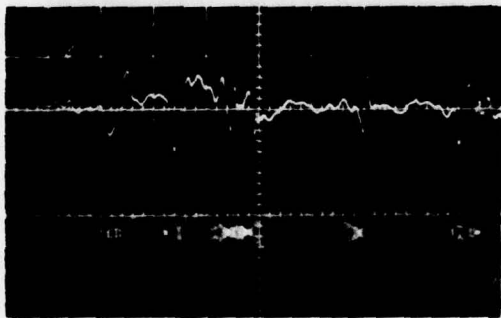

← CW →
f = 5070 S/N = 0 dB

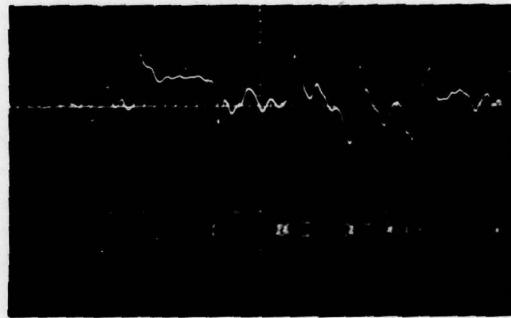

← CW →
f = 5070 S/N = 10 dB

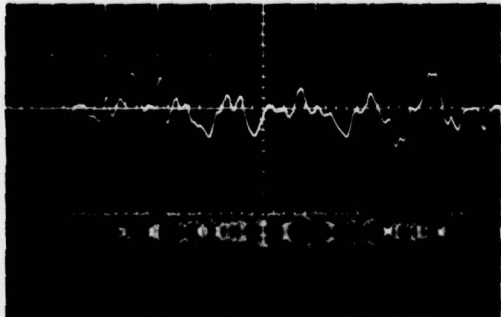

NOISE ALONE

Figure 10b. Same as 10a except that the pulse length is 30 ms and the noise bandwidth is 35 Hz.

CONFIDENTIAL

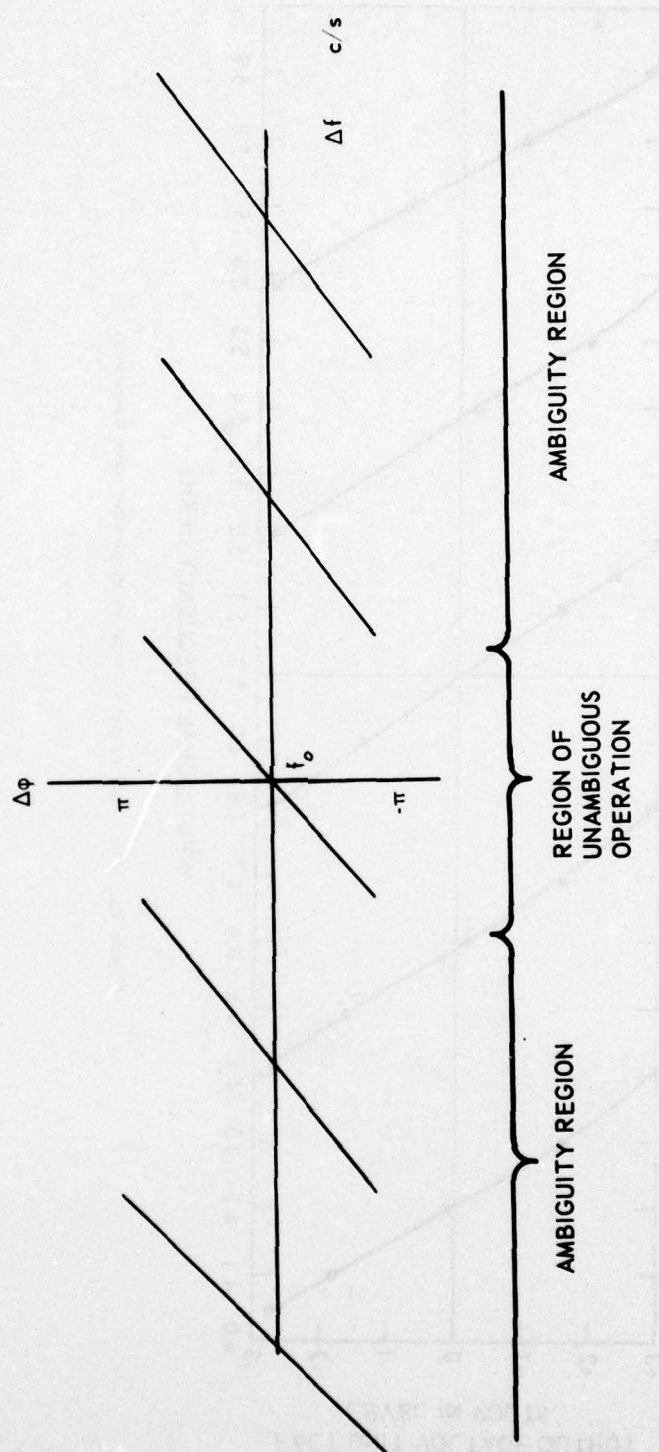

Figure 11. Phase shift vs frequency deviation for delay line processor.

CONFIDENTIAL

CONFIDENTIAL

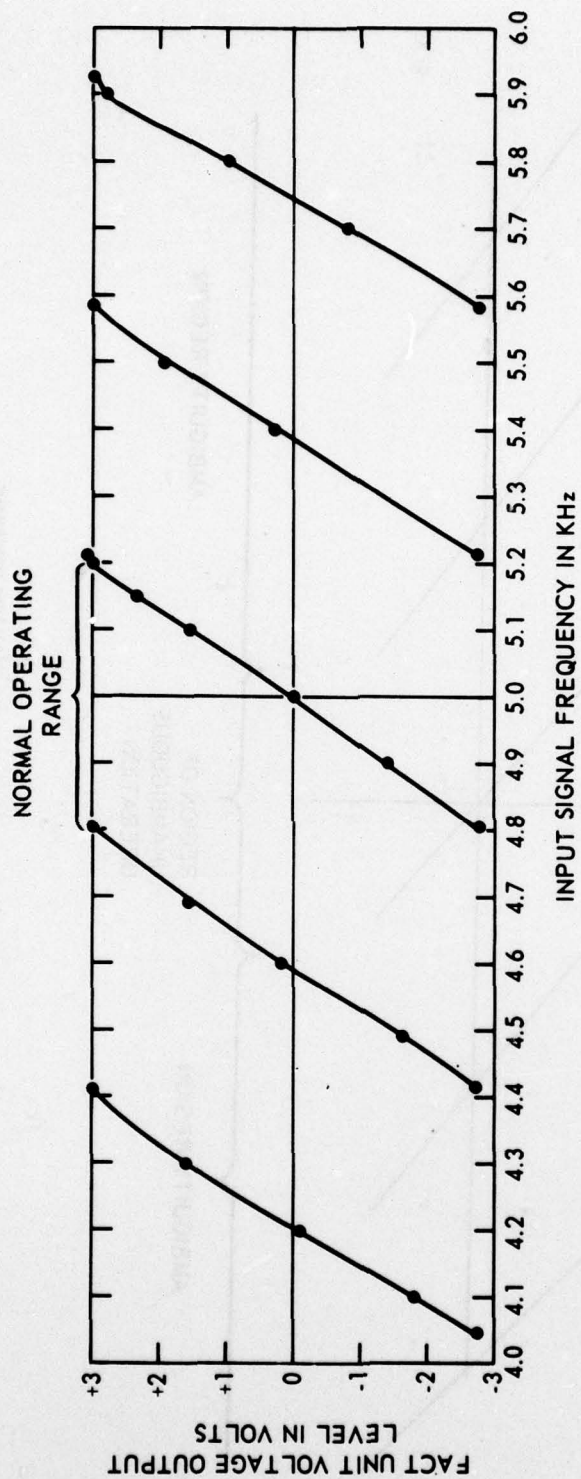

Figure 12. FACT unit output voltage vs input sine wave frequency.

CONFIDENTIAL

CONFIDENTIAL

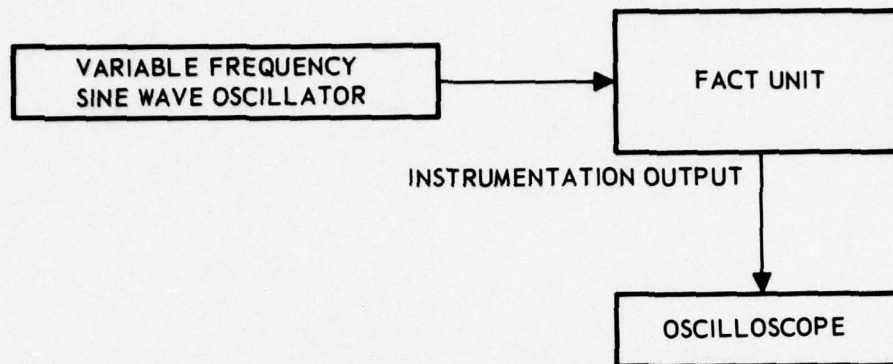
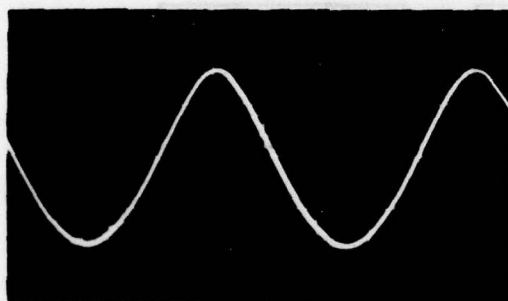
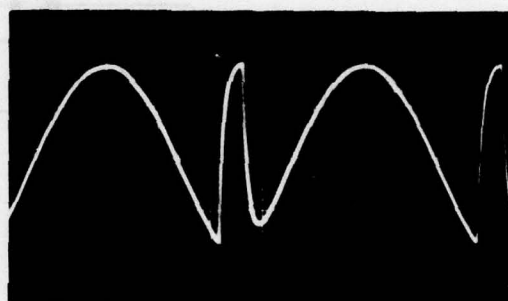

Figure 13. Experimental configuration used for measuring output level vs frequency.



Here the frequency swing is within normal FACT operating range.

14a



Here the frequency swing has been slightly increased so that it just crosses the first upper foldover point.

14b

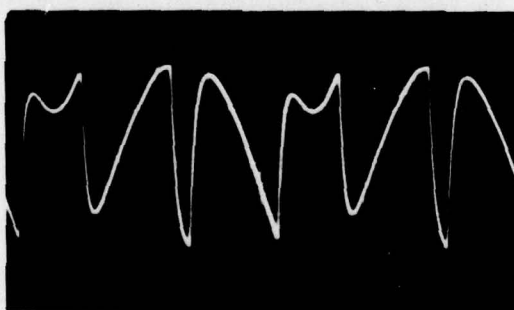

Here the frequency swing has been increased still further so that it crosses both the first upper and lower foldover points.

14c

Figure 14. Photographs showing the FACT unit output for a sinusoidally modulated FM input signal. The modulation frequency was held constant at 10 Hz while the frequency swing was varied as indicated below each photo.

CONFIDENTIAL

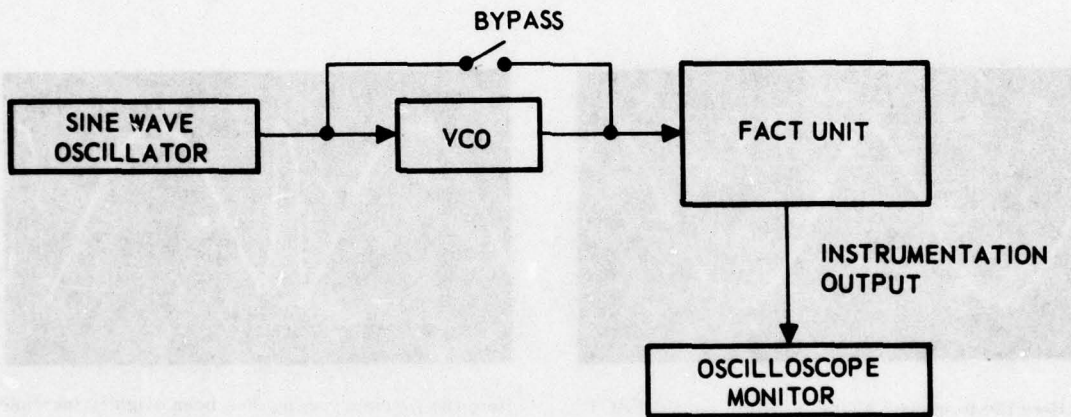

Figure 15. Experimental configuration for frequency foldover tests.

CONFIDENTIAL

CONFIDENTIAL

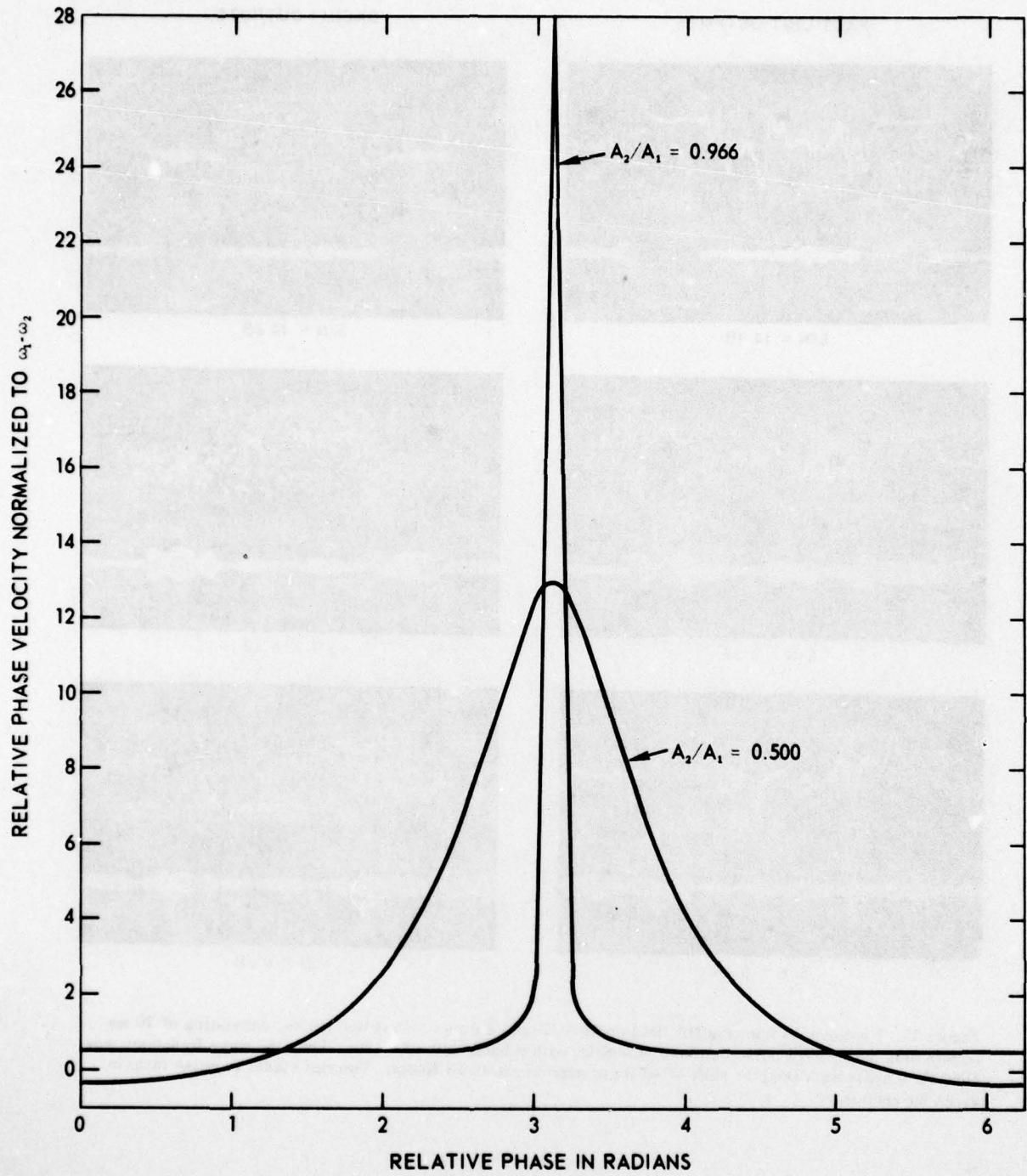

Figure 16. Relative phase velocity vs relative phase over one cycle of the difference frequency for a two sine wave signal of the form $x(t) = A_1 \sin \omega_1 t + A_2 \sin \omega_2 t$.

CONFIDENTIAL

CONFIDENTIAL

FACT UNIT OUTPUTS

DACIM I OUTPUTS

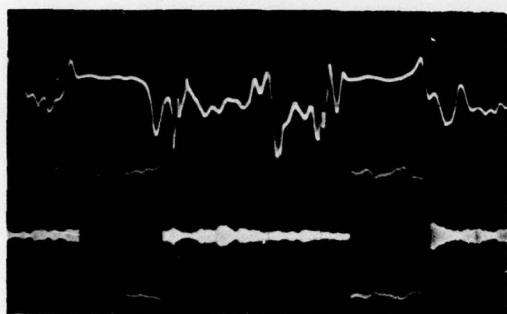

S/N = 14 dB

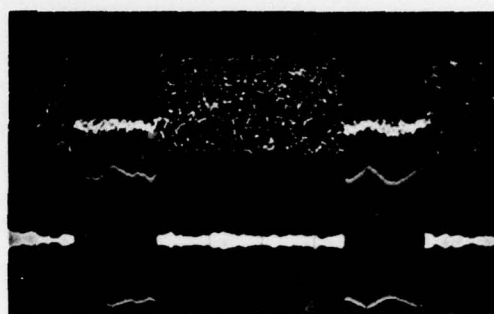

S/N = 14 dB

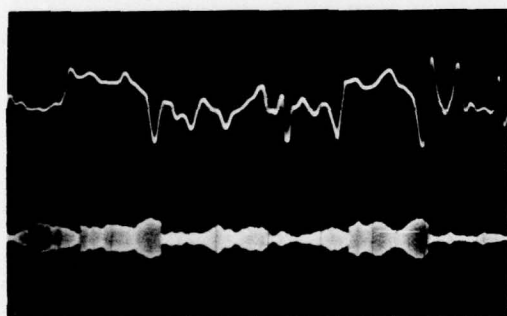

S/N = 6 dB

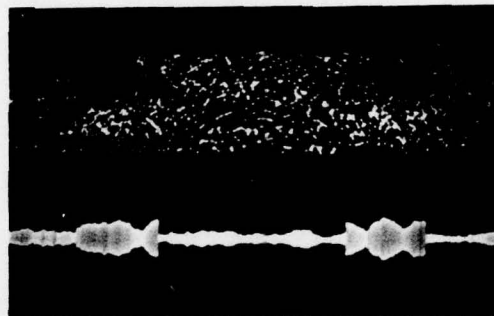

S/N = 6 dB

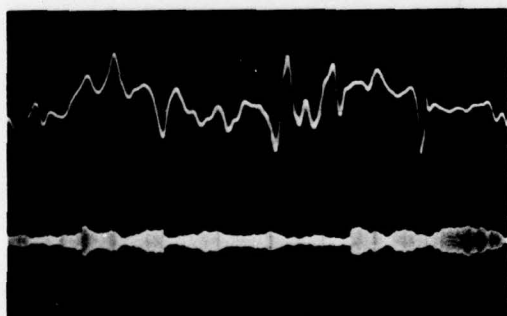

S/N = 0 dB

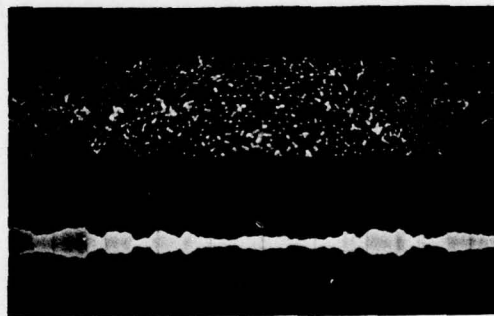

S/N = 0 dB

Figure 17. Photographs showing DACIM I and FACT unit outputs for similar inputs, consisting of 30 ms pulses plus narrowband noise centered at 5 KHz, with a bandwidth of 35 Hz. The sine wave frequency was 5080 Hz simulating a Doppler shift of 80 Hz or approximately 23 Knots. The rms signal to noise ratio is given for each trace.

CONFIDENTIAL

FACT UNIT



DACIM I

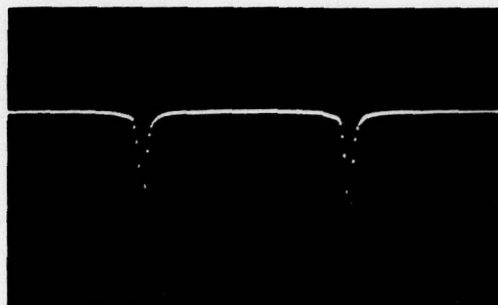

Figure 18. Photographs showing the FACT unit and DACIM I outputs for an input consisting of two sine wave components. The input signal is given by the relation $x(t) = A_1 \sin(2\pi f_1 t) + A_2 \sin(2\pi f_2 t)$ where $f_1 = 5010$ Hz, $f_2 = 5000$ Hz, $A_1 = 1.1$ vrms and $A_2 = 1.0$ vrms. The FACT unit Doppler scale is approximately 100 Knots/division. The DACIM I Doppler scale is approximately 50 Knots/division.

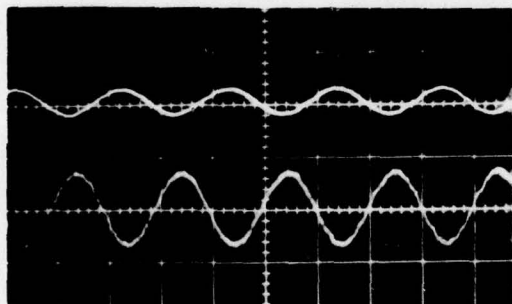

Figure 19. Photograph showing FACT unit output (upper trace) and DACIM I output (lower trace) for an FM sinusoidally modulated input signal where the modulation is 10 Hz and the frequency swing is 100 Hz.

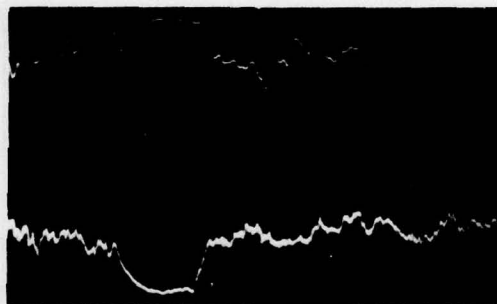

Figure 20. Photograph showing FACT unit output (upper trace) and DACIM I output (lower trace) for an input consisting of a CW pulse plus narrowband noise. The pulse length is 30 ms and the noise bandwidth is 35 Hz. The DACIM I output has been smoothed using an RC network. The vertical scales are approximately 50 Knots/div. for FACT output and 25 Knots/div. for DACIM I output.

CONFIDENTIAL

CONFIDENTIAL

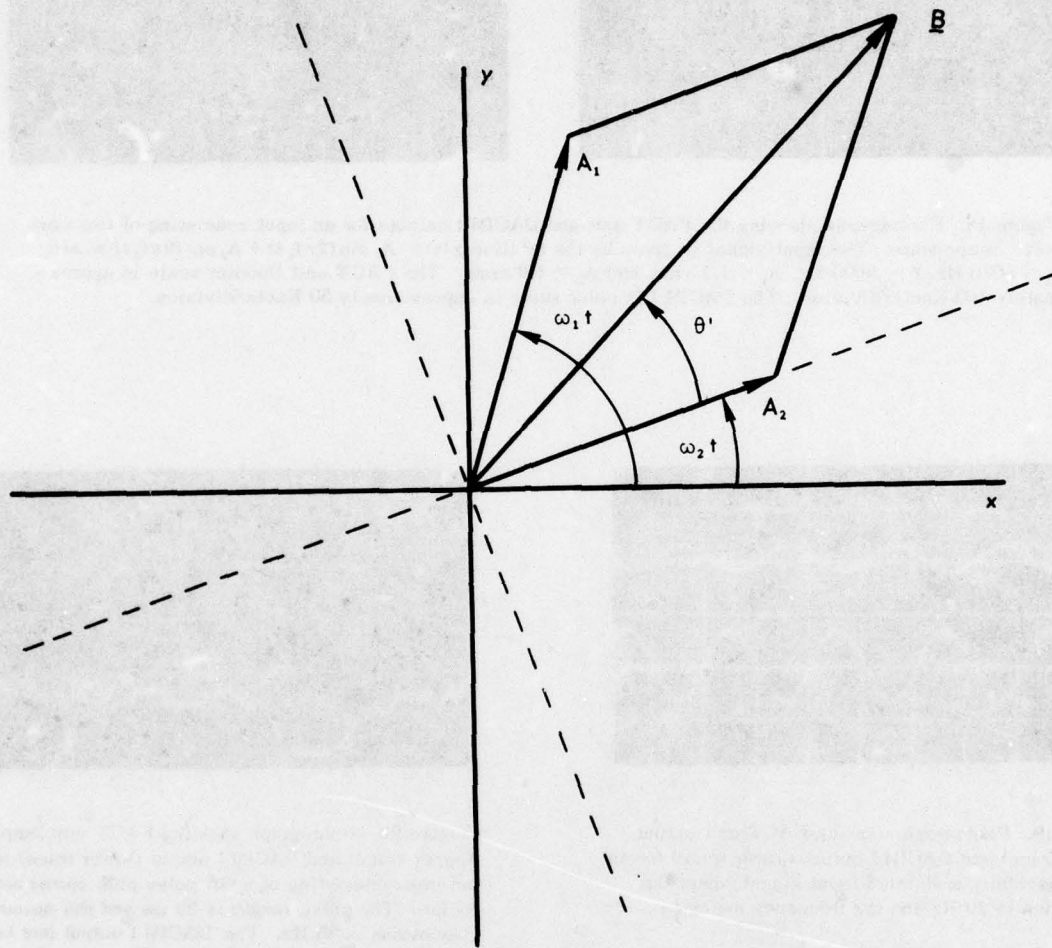

Figure 21. Phasor diagram for signal with two sine wave components.

CONFIDENTIAL

UNCLASSIFIED

~~CONFIDENTIAL~~

REFERENCES

1. COMDESDEVPAC. Quarterly Progress Report. February-April, 1963 (CONF.)
2. Hampton, L. D. and Goodnow, R. K., *Evaluation of the Bendix Monoppler Using the SME-AN SQS-23 Playback Facility*, TM 93124-66-2. University of Texas, Defense Research Laboratory, 9 May 1966.
3. *Instruction Manual for Monoppler Unit*, Report # 8-1496, Bendix Corporation, North Hollywood, California, 30 July, 1965 (CONF.).
4. Rice, S.O., "Noise in FM Receivers" chapt. 25, pp.375-424, *Proceedings Symposium on Time Series Analysis*, M. Rosenblatt, ed. John Wiley & Sons, Inc. New York, 1963.
5. Gerlach, A. A., *Theory and Applications of Statistical Wave Period Processing*, Chapter 7. Cook Electric Co., June, 1967.
6. Nesheim, J.A., *Digital Axis-Crossing Interval Measurement System (DACIM I)* NUWC TN (to be published).
7. Schwartz, M., *Information Transmission, Modulation and Noise*. p.49, McGraw-Hill, New York, 1959.

~~CONFIDENTIAL~~
UNCLASSIFIED

UNCLASSIFIED

~~CONFIDENTIAL~~

THIS PAGE INTENTIONALLY LEFT BLANK

~~CONFIDENTIAL~~

UNCLASSIFIED