

LOAN DOCUMENT TRANSMITTAL

DATE ACCESSIONED 9 APR 1979
REPORT NUMBER FTD-ID(RS)T-2044-78
AD NUMBER AD-A067142

THE ATTACHED DOCUMENT HAS BEEN LOANED
TO DDC FOR PROCESSING.

THIS COPY IS NOT TO BE MARKED OR MUTI-
LATED. REQUEST THAT SPECIAL HANDLING,
BE PROVIDED IN ORDER THAT THE COPY MAY
BE PROMPTLY RETURNED TO THE LENDER.

THE REPORT SHOULD BE RETURNED TO

DDC DOCUMENT PROCESSING

DIVISION / DDA-21 ATTN: P.F. COOPER

ACCESSION FOR	
NTIS GRA	<input checked="" type="checkbox"/>
DDC TAB	<input type="checkbox"/>
UNANNOUNCED	<input type="checkbox"/>
JUSTIFICATION	_____
_____	_____
_____	_____
BY	_____
DISTRIBUTION/AVAILABILITY CODES	
DIST.	AVAIL. AND/OR SPECIAL
<u>A</u>	

DO NOT PHOTOGRAPH THIS FORM

LOAN DOCUMENT

1

FOREIGN TECHNOLOGY DIVISION



COMBUSTION IN A FLOW
(Selected Articles)

DDC
RECEIVED
9 APR 1979
E



Approved for public release;
distribution unlimited.

FTD-A067142



79 03 06 116

UNEDITED MACHINE TRANSLATION

FTD-ID(RS)T-2044-78	15 January 1979
MICROFICHE NR: <i>7AD-79-C-000120</i>	
CSC71123268	
COMBUSTION IN A FLOW (SELECTED ARTICLES)	
English pages: 85	
Source: Trudy Kazanskogo Aviatsionnogo Instituta (Kazan) Nr. 124, 1970, pp. 98-110, 123-132, 133-159.	
Country of origin: USSR	
This document is a machine translation.	
Requester: FTD/TQTA	

Approved for public release; distribution unlimited.

ACCESSION for	
NTIS	<input checked="" type="checkbox"/> Micro Section
DOC	<input type="checkbox"/> Off Section
UNCLASSIFIED	<input type="checkbox"/>
BY	
DI: TRIBUTIGN/AVAILABILITY CODES	
Dist	SPECIAL
<i>A</i>	

<p>THIS TRANSLATION IS A RENDITION OF THE ORIGINAL FOREIGN TEXT WITHOUT ANY ANALYTICAL OR EDITORIAL COMMENT. STATEMENTS OR THEORIES ADVOCATED OR IMPLIED ARE THOSE OF THE SOURCE AND DO NOT NECESSARILY REFLECT THE POSITION OR OPINION OF THE FOREIGN TECHNOLOGY DIVISION.</p>	<p>PREPARED BY:</p> <p>TRANSLATION DIVISION FOREIGN TECHNOLOGY DIVISION WP-AFB, OHIO.</p>
---	---

79 03 06 116

U. S. BOARD ON GEOGRAPHIC NAMES TRANSLITERATION SYSTEM

Block	Italic	Transliteration	Block	Italic	Transliteration
А а	А а	A, a	Р р	Р р	R, r
Б б	Б б	B, b	С с	С с	S, s
В в	В в	V, v	Т т	Т т	T, t
Г г	Г г	G, g	У у	У у	U, u
Д д	Д д	D, d	Ф ф	Ф ф	F, f
Е е	Е е	Ye, ye; E, e*	Х х	Х х	Kh, kh
Ж ж	Ж ж	Zh, zh	Ц ц	Ц ц	Ts, ts
З з	З з	Z, z	Ч ч	Ч ч	Ch, ch
И и	И и	I, i	Ш ш	Ш ш	Sh, sh
Й й	Й й	Y, y	Щ щ	Щ щ	Shch, shch
К к	К к	K, k	Ъ ъ	Ъ ъ	"
Л л	Л л	L, l	Ы ы	Ы ы	Y, y
М м	М м	M, m	Ь ь	Ь ь	'
Н н	Н н	N, n	Э э	Э э	E, e
О о	О о	O, o	Ю ю	Ю ю	Yu, yu
П п	П п	P, p	Я я	Я я	Ya, ya

*ye initially, after vowels, and after ъ, ь; e elsewhere.
When written as ě in Russian, transliterate as yě or ě.

RUSSIAN AND ENGLISH TRIGONOMETRIC FUNCTIONS

Russian	English	Russian	English	Russian	English
sin	sin	sh	sinh	arc sh	sinh ⁻¹
cos	cos	ch	cosh	arc ch	cosh ⁻¹
tg	tan	th	tanh	arc th	tanh ⁻¹
ctg	cot	cth	coth	arc cth	coth ⁻¹
sec	sec	sch	sech	arc sch	sech ⁻¹
cosec	csc	csch	csch	arc csch	csch ⁻¹

Russian English

rot curl
lg log

TABLE OF CONTENTS

U. S. Board on Geographic Names Transliteration System, Russian and English Trigonometric Functions.....	i
Effect of the Design of Stabilizer on the Character- istic of Smooth Burning of Liquid Sprayed Fuel, by K. V. Kakhovskiy, F. M. Mingaleyev, Ye. D. Nesterov....	1
Special Features of Gas-Dynamic (JET) Stabilization of a Flame in Flow of a Combustible Mixture with a Heterogeneous Composition, by I. P. Motylinskiy, V. A. Kosterin, Yu. S. Alekseyev.....	24
Stabilization of Flame in Gas-Dynamic Precombustion Chambers, by M. Sh. Gilyazov, V. A. Kosterin, F. K. Smorodin.....	44
Calculation of Combustion Chamber with Flame Holders, by V. A. Kosterin, B. A. Rogozhin, V. T. Dudkin.....	58

EFFECT OF THE DESIGN OF STABILIZER ON THE CHARACTERISTIC OF SMOOTH BURNING OF LIQUID SPRAYED FUEL.

K. V. Kakhovskiy, P. M. Mingaleyev, Ye. D. Nesterov.

Page 98.

In work are given the results of the investigation of the effect of the character of the supply of air at the root of the fuel flame of injector on the range of smooth burning of the liquid atomized fuel. It is shown, that the flameout in stabilizer with leaning-out of mixture in certain cases is given rise to by the transition of the process of microdiffusible combustion into kinetic region.

One of the most important requirements, presented to the combustion chamber of gas turbine engine, is the provision for a broad band of smooth burning in the camera/chamber in all engine power ratings in flight. With flight operation are possible the cases of powerful impoverishment or enrichment of fuel-air mixture in the camera/chamber with sharp jettisoning or increase in engine revolutions. In order to avoid the extinction of flame in the

camera/chamber, which can lead to the emergency of aircraft, it is necessary to have data on the range of smooth burning during a change in the airstream data at the entrance into the camera/chamber (P_2 , T_2 , W_2). In the camera/chamber of the GTD [gas-turbine engine], occurs the process of the combustion of the sprayed fuel/propellant in a turbulent flow which is studied to a lesser degree than the process of the combustion of uniform fuel-air mixture. It is concealed by form, is necessary the accumulation of experimental material on the investigation of physics of the combustion of heterogeneous mixture and mechanism of the stabilization of flame.

Page 99.

Figure 1 gives the typical region of smooth burning in the combustion chamber of GTD, which is limited to two breakaway characteristics of the camera/chamber:

the characteristic of "lean" flameout;

the characteristic of "rich" flameout.

The region of smooth burning of uniform mixture, conditionally shown on Fig. 1, has a form which is characterized by the form of the characteristic of "lean" disruption/separation. During the supplying

through the injector of vaporous fuel/propellant, the characteristic of "lean" flameout approaches in form an analogous characteristic during the combustion of uniform mixture [1]. Consequently, the form of the characteristic of "lean" flameout, the homogeneous mixture to a considerable degree is determined by the condition of feeding the fuel/propellant. The characteristic of "lean" disruption/separation can be conditionally divided on 3 stability regions with respect to the velocity of air (Fig. 1):

1. Region A.* The excess air ratio during flameout is proportional to air speed ($\alpha_{cp} \sim W$).

2. Region B.* The excess air ratio during flameout does not depend on air speed ($\alpha_{cp} \approx \text{const}$).

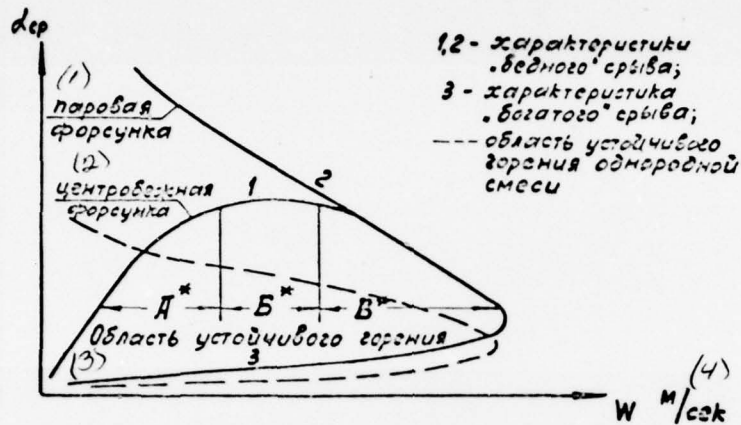

Fig. 1. Region of smooth burning in combustion chamber of GTD. 1, 2 - characteristic of "lean" disruption/separation; 3 - characteristic of "rich" disruption/separation; --- the region of steady combustion of uniform mixture.

Key: (1). The steam jet. (2). Centrifugal injector. (3). Region of smooth burning. (4). m/s.

Page 100.

3. Region C*. The excess air ratio during flameout is inversely proportional to air speed ($\alpha_{cp} \sim \frac{1}{W}$).

In works M. F. Bortnikova is given the explanation of the

mechanisms of flameout with leaning-out of mixture in the chamber operation of combustion in different regions on air speed. In chamber operation in stability region A*, flameout occurs as a result of the cessation of fuel atomization by injector during the decrease of the fuel consumption in the region of the low air flow rates. Flameout in chamber operation in stability region B* is determined by the condition for existence of the diffusion front of flame, i.e., by the condition $\alpha=1$.

The stability of the process of combustion in the field high air speeds C* is determined by the relationship/ratio of the time of fuel evaporation τ_u to the retention time of fuel-air mixture in the zone of circulation τ_{np} , by condition $\tau_u/\tau_{np} = 1$. Depending on the thermodynamic and aerodynamic flow parameters, the extent of the regions of smooth burning will change and possible the cases when region B* disappears as a result of the joining of regions A* and C*. In view of too complex a situation, in which occurs the process of combustion in full-scale combustion chambers, in this work conducted experimental investigation of the stability characteristics of flame $\alpha_{sp} = f(w)$ during the combustion of the liquid atomized fuel on separate stabilizers in connection with front equipment/device of combustion chamber of GTD.

Description of experimental installation and procedure of study.

The experimental study of the characteristics of smooth burning of the liquid atomized fuel was conducted during the installation whose schematic was represented in Fig. 2. Air with temperature $t_a = +10 + 20^\circ\text{C}$ through the throttle plate was fed along duct to stabilizer 1. Fuel/propellant (kerosene FS-1) with temperature $t_f = +15^\circ\text{C}$ proceeded to the injector through needle valve/gate 5. The combustion of fuel-air mixture occurred in the atmosphere.

Page 101.

The types of the stabilizers being investigated are represented in Fig. 3. Injectors in stabilizers the centrifugal, single-channel with diameter nozzles of sprayer $d_{cp} = 0,75 \text{ mm}$.

The experimental procedure consisted of following. After the inflammation of mixture from the extraneous flame jet was established the assigned air-pressure differential on stabilizer ΔP_s . By gradual decrease or increase in fuel consumption with the aid of needle valve was achieved the conditions/mode of the extinction of flame in stabilizer. The air speed in the opening/apertures of stabilizers varied in the range $w_0 = 40-100 \text{ m/s}$, which corresponds to the speed range of air in opening/apertures and slots of front

equipment/devices of the combustion-chamber linings of STD. The flow rate of air was measured with the aid of graduated diaphragm, the fuel consumption it was determined from the discharge characteristic of injector.

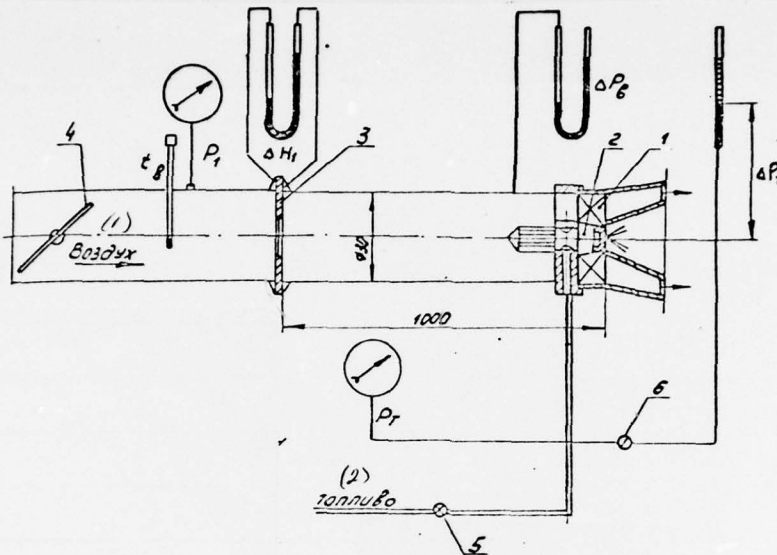

Fig. 2. Measuring circuit on installation. 1 - stabilizer; 2 - injector; 3 - graduated diaphragm; 4 - the throttle plate; 5 - needle valve/gate; 6 - the stop cock.

Key: (1) . Air. (2) . fuel.

Page 102.

A jump/drop in the pressure fuel/propellant on injector ΔP_T was located through piezometer through the value of the column of kerosene in piezometer relative to the axis of injector. For the

analysis of aerodynamic flow pattern, was conducted the measurement of velocity fields in the section/shear of stabilizer with the aid of total pressure tube.

Results and analysis of experimental data.

On a stabilizer of the type A, was conducted the investigation of the effect of the supply of air in section II-II and III-III on the characteristic of "lean" flameout. In initial version the stabilizer was made with the annular slot with a height/altitude of 1 mm in section IV-IV, in the remaining sections of opening/aperture for the supply of air, they were absent. The study of combustion stability was conducted in the small speed range of air in opening/apertures $w_0=40-60$ m/s, that somewhat impedes the analysis of dependence $\alpha_{cp} = f(w_0)$, but it permits to evaluate the effect of the character of the supply of air over the length of stabilizer on the absolute value of the excess air ratio during flameout.

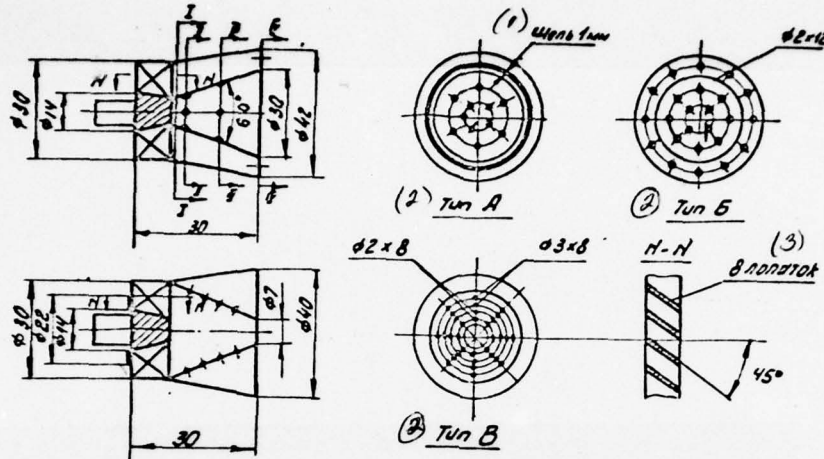

Fig. 3. Types of stabilizers.

Key: (1). Slot. (2). Type. (3). blades.

Page 103.

During the decrease of the fuel consumption, the combustion zone was reduced along the length and approached an end/face of stabilizer, the extinction of flame occurred within stabilizer. The measurement of velocity fields showed that in stabilizer is formed the zone of circulation M because of the ejection of air in stabilizer by the annular jet, which escape/ensues from slot (Fig. 4). Fuel combustion in preflameout conditions/modes occurred in the zone of circulation.

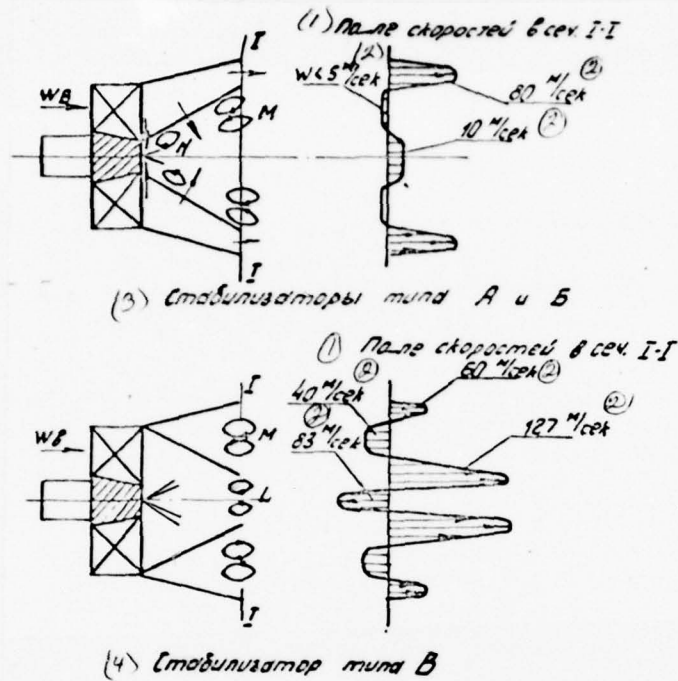

Fig. 6. Mechanism of the stabilization of flame in stabilizers.

Key: (1). Velocity field in cross sect. (2). m/s. (3). Stabilizers of type "A" and B. (4). Stabilizer of type C.

Page 104.

Observation of the character of the discharge of fuel/propellant behind blast nozzle under the conditions of flameout showed that the injector does not virtually spatter fuel/propellant with jump/drops

in pressure $\Delta P_t \approx 0,1 \cdot 10^5 \text{ N/m}^2$ and fuel/propellant escape/ensues from stabilizer by separate streams. For an improvement in the quality of fuel atomization in preseparation conditions/modes at the root of fuel flame in section II-II, arrange/located at a distance of 3 mm from blast nozzle, was conducted the air through 5 tangential opening/apertures with a diameter of 1.5 mm. The excess air ratio α_{cp} during disruption/separation increased from 0.35 to 0.8 (Fig. 5). For a more effective effect on fuel flame in section II-II, were made 6 radial opening/apertures with a diameter of 2 mm which in comparison with tangential ones have the large depth of penetration of air jets. The quantity of air, applied at the root of fuel flame, increased 2 times.

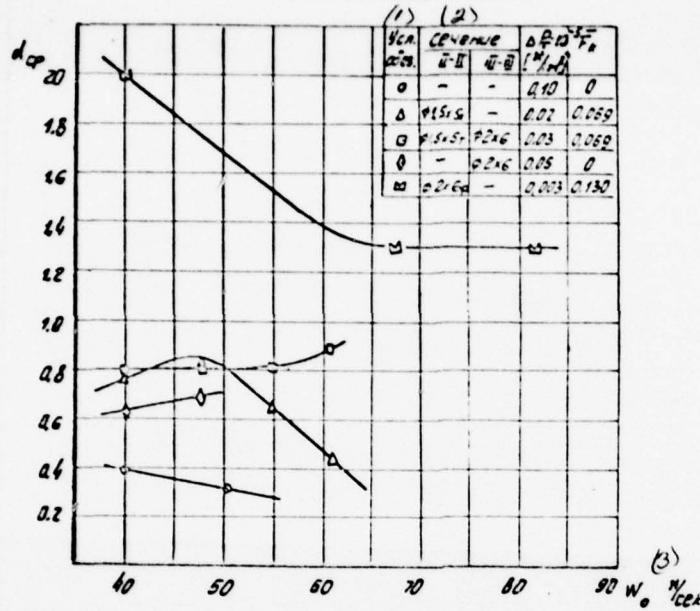

Fig. 5. Characteristics of "lean" flameout in a stabilizer of the type A.

Key: (1). Conv. Flameout. (2). Section. (3). n/s.

Page 105.

As a result of the supply of the air through radial opening/apertures, the excess air ratio of flameout increased 2.5 times ($d_{cp} = 2,0$). Consequently, the quantity of air, applied at the root of fuel flame, has considerable effect on the range of smooth burning of the liquid atomized fuel. The consideration of

dependences for a stabilizer of the type A shows that with an increase in the air speed in opening/apertures the excess air ratio during flameout decreases, that permits us the conditions/mode of disruption/separation to relate to stability region C*, i.e., the process of combustion in preseparation conditions/mode is limited by the process of evaporating the drops of fuel/propellant. The supply of air in section III-III, arranged/located at a distance of 10 mm from blast nozzle, does not affect characteristic $\alpha_{cp} = f(w_0)$ in the range of air speeds $w_0 = 40-50$ m/s, but it prevents decrease α_{cp} during increase w_0 (Fig. 5). It is possible to assume that in this case appears the supplementary zone of circulation N, which is formed because of the ejection of air by central jets (Fig. 4). The zone of circulation N can serve as the supplementary source of the stabilization of flame and contribute to more rapid evaporation of the drops of fuel, providing the transition of the conditions/modes of flameout from stability region C* into region B*, where α_{cp} it does not depend on w_0 .

More detailed study of the effect of the character of the supply of air along the length of fuel flame on the range of smooth burning was conducted on a stabilizer of the type B, in this case, the air speed in opening/apertures changed in the range $w_0 = 40-90$ m/s. Investigation was conducted on three separate stabilizers. Combustion in preseparation conditions/modes occurs in the zone of circulation N

(Fig. 4) and in a stabilizer of the type A. During the investigation of the effect of a quantity of spattering air on the region of stable combustion, the air was fed through the annular slot of different height/altitude in the end/face of blast nozzle. The results of investigation are represented in Fig. 6. For the analysis of the effect of a quantity of spattering air on the characteristic of "lean" flameout on Fig. 7 are constructed dependences

$\alpha_{cp} = f\left(\bar{F}_k = \frac{F_k}{\Sigma F_{orb}}\right)$ with $W_0 = \text{const.}$ From the examination of Fig. 7, it is evident that there has an optimum value of the relative area of slot in the end/face of the injector: $\bar{F}_k = 0,45$.

Page 106.

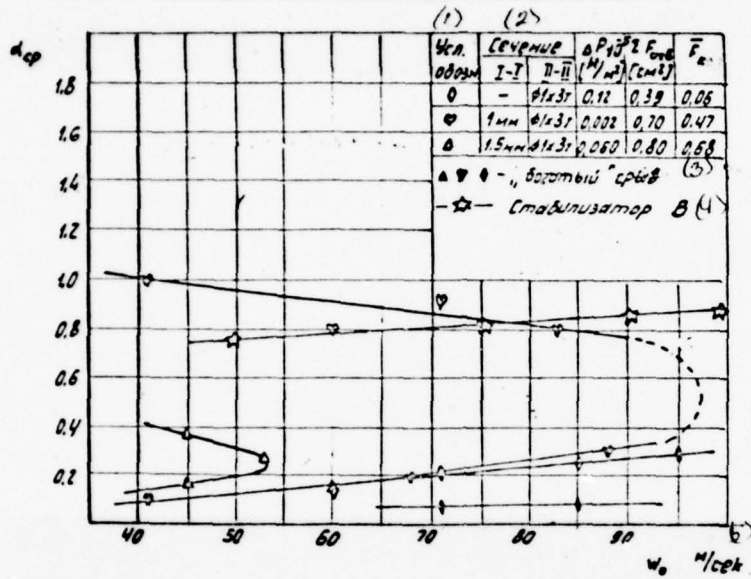

Fig. 6. Regions of smooth burning in stabilizers of type "B" and C.

Key: (1). Designation. (2). Section. (3). "Rich" disruption/separation. (4). Stabilizer. (5). m/s.

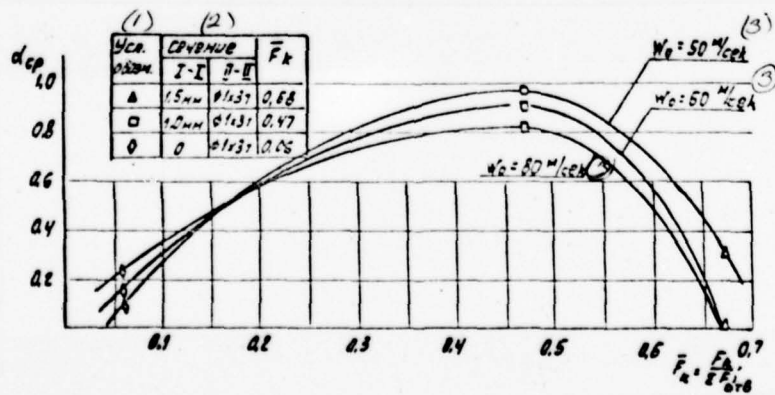

Fig. 7.

Fig. 7. Dependence of excess air ratio during "lean" flameout in stabilizer of type B on quantity of spattering air.

Key: (1). Designation. (2). Section. (3). m/s.

Page 107.

Consequently, a considerable increase in the quantity of spattering air ($\bar{F}_k > 0,45$) leads to decrease α_{cp} and to the contraction of an entire field of smooth burning, which is explained by the prevailing effect of the retention time of mixture in stabilizer in comparison with an improvement in the quality of fuel atomization. The effect of the quality of fuel atomization by injector on combustion stability is also confirmed by the results of experiment (Fig. 8). When making a small scratch ($\delta=0.1$ mm) on the nozzle of injector nozzle fuel cone becomes asymmetric relative to the axis of stabilizer, which leads to the impoverishment of fuel-air mixture in the place of the deviation of fuel flame from the wall of stabilizer and as consequence - to early flameout. Figure 9 depicts to the region of smooth burning in stabilizer during a change in the quantity of air, applied through central opening/apertures in section II-II. With an increase in the quantity of air, supplied through central opening/apertures, occurs the contraction of the region of smooth burning, which, possibly, is connected with the decrease of the retention time of fuel-air mixture in stabilizer.

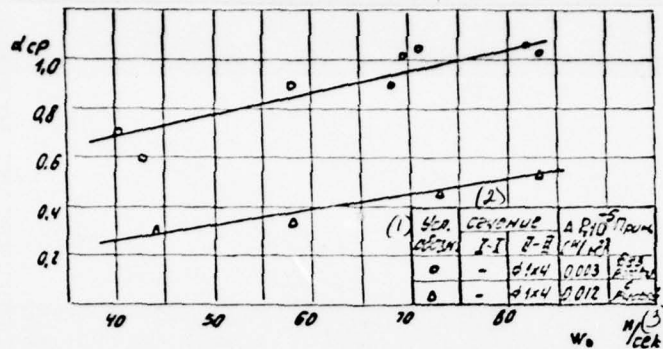

Fig. 8. Effect on the characteristic of "lean" flameout in a stabilizer of the type B of the quality of fuel atomization by injector.

Key: (1). Designation. (2). Section. (3). m/s.

Page 108.

It should be noted that a stabilizer of the type B made it possible to obtain smooth burning at the values of a jump/drop in the pressure fuel/propellant $\Delta P_f = 30 \text{ N/m}^2$, i.e., virtually before the complete failure of fuel. A stabilizer of the type B can be used in combustion chambers, to which are presented the requirements of the provision for smooth burning when $\alpha_{cp} > 100$.

The study of the effect of the premixing of fuel/propellant with

air on the characteristic of "lean" flameout was carried out on a stabilizer of the type C whose design concept was represented in Fig. 3. The premixing of fuel/propellant with air makes it possible to obtain good fuel atomization with insignificant jump/drops in the pressure fuel/propellant. An increase in the air speed in the range $W_0=50-100$ m/s does not virtually change the value of the excess air ratio during "lean" flameout (Fig. 6). The aerodynamic investigation of flow pattern shows that in stabilizer is formed two zones of circulation M and L, the zone of circulation M being circular vortex pair. During the decrease of the fuel consumption, occurs the extinction of flame at first in the zone of circulation L, and then in the zone of circulation M.

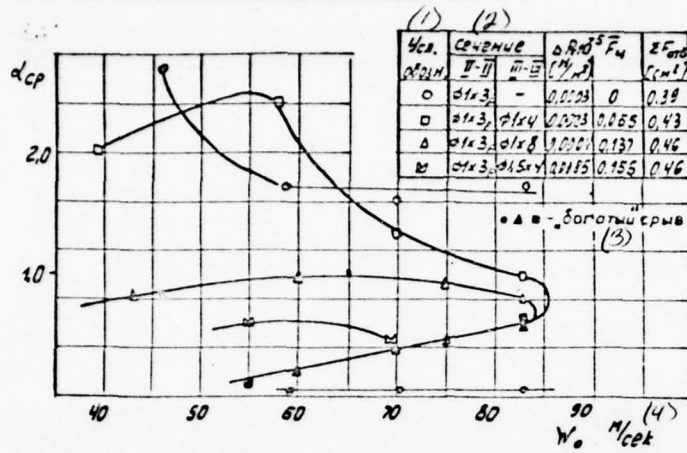

Fig. 9. Region of smooth burning in a stabilizer of the type B.

Key: (1). Designation. (2). Section. (3). "Rich" disruption/separation. (4). m/s.

Page 109.

The best stabilizing ability of the zone of circulation M is explained by the high size/dimensions of zone and the possibility of the closing/shorting of flame front on the ring of eddy/vortex.

We analyze thoroughly the form of dependence $\alpha_{cp} = f(w_0)$ for a stabilizer of the type C. In work [2] was conducted the study of the mechanism of combustion after screens at air speed 20-40 m/s, when fuel/propellant was introduced with the aid of the swirl injector

into wake after screen. Experiments showed that the size/dimensions of flame jet weakly depend on the speed of airflow, which serves as the confirmation of the mechanism of microdiffusible turbulent combustion, i.e., occurs the diffusion combustion of small volumes of fuel/propellant in vapor phase, distributed in airflow. During an increase in the velocity of airflow, occurs the transition of the process of microdiffusible combustion into kinetic region, i.e., combustion period will be determined not by the time of mixing, but chemical reaction time. D. A. Franck-Kamenetskiy identifies the transition of combustion into kinetic region with flameout. During the study of combustion stability in a stabilizer of the type C, the size/dimensions of combustion zone in preflameout conditions/modes did not virtually change during an increase in the air speed. During the decrease of the fuel consumption, the color of flame varied from yellow to azure. The azure color of flame during combustion in preseparation conditions/mode attests to the fact that occurs the combustion of vaporous fuel/propellant, but not the drops which during combustion color flame the yellow. Thus, the color of flame and the character of dependence $\alpha_{cp} = f(W_0)$ serve as the confirmation of the fact that in stability region B* in preseparation conditions/mode occurs the process of microdiffusible combustion.

During the study of a stabilizer of the type B, also was observed the azure color of flame during combustion in preseparation

conditions/mode, but the character of dependence $\alpha_{cp} = f(W_0)$ can be attributed to stability region C*, since the excess air ratio during "lean" flameout decreased with an increase in the air speed. The comparison of the region of smooth burning in stabilizer with the region of smooth burning of uniform mixture, undertaken from work [3] (Fig. 10), indicates the great similarity of the regions of smooth burning on its geometry.

Page 110.

It is possible to assume that in a stabilizer of the type B the flameout is given rise to by the transition of the process of microdiffusible combustion into kinetic combustion, which serves as the confirmation of D. A. Franck-Kamenetskiy's hypothesis.

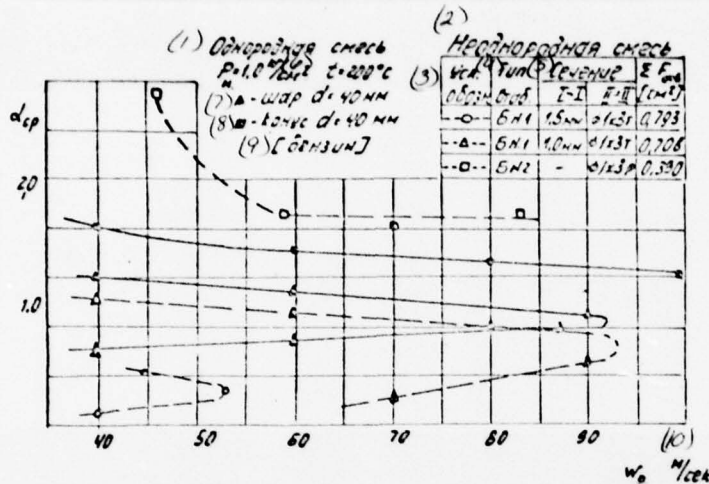

Fig. 10. Comparison of the region of smooth burning in a stabilizer of the type B with the region of smooth burning of uniform mixture.

Key: (1). Uniform mixture. (2). Heterogeneous mixture. (3). Designation. (4). Type of stab. (5). Section. (6). kg/cm². (7). sphere. (8). cone. (9). Gasoline. (10). m/s.

REFERENCES

1. Дорощенко В.Е. О процессе горения в камере ГТД. Труды института им.Л.И.Баранова, № 354, 1959.
2. Франк - Каменецкий Д.А., Минский Е.М. Микродиффузионное турбулентное горение. ДАН СССР, т.50, 1945.
3. Раушенбах Б.В. и др. Физические основы рабочего процесса в камерах сгорания воздушно-реактивных двигателей. М., "Машиностроение", 1964.

Received 3 July, 1969.

Page 123.

SPECIAL FEATURES OF GAS-DYNAMIC (JET) STABILIZATION OF A FLAME IN FLOW OF A COMBUSTIBLE MIXTURE WITH A HETEROGENEOUS COMPOSITION.

I. P. Motylinskiy, V. A. Kosterin, Yu. S. Alekseyev.

Are investigated the limits of smooth burning during the gas-dynamic stabilization of flame in flow of heterogeneous in composition of combustible mixture.

It is shown, that the parameter, which are determining limits of the stabilization of flame, is the excess air ratio in the zone of circulation (zone of return currents).

In combustion chambers, the feed of fuel/propellant into airflow, as a rule, is conducted in immediate proximity of flame holders. These forming in cases combustible mixture is heterogeneous in composition, and with the injection of liquid propellant - even on phase. This substantially complicates the examination of the

processes taking place and creates supplementary difficulties in identification of the parameter, which is determining the limits of stable (without flameout) combustion in flow.

The limits of the stabilization of flame in trace after the poorly streamlined body for heterogeneous two-phase flows were examined by V. F. Dunskiy [1].

The thorough analyses of the stabilization of flame on the poorly streamlined bodies in flow of heterogeneous in composition evaporated combustible mixture are carried out by B. P. Lebedev.

Page 124.

In contrast to known works in our experiments, are studied the special feature/peculiarities of the stabilization of a flame in the nonuniform flows on the adjustable by the size/dimensions and the chemical composition jet-edge screens.

The schematic of experimental installation is represented in Fig. 1.

Air with compressor was supplied to combustion chamber 1, where it was preheated before the assigned temperature because of the

combustion of certain quantity of kerosene.

Uniform combustible mixture was created by the feed of fuel/propellant - kerosene T-1 - into airflow through collector/receptacle 2, adjustable on sufficient distance from experimental section 4. For an improvement in the mixing, was establish/installated mixer 3.

Heterogeneous mixture was obtained during the supplying of the fuel/propellant through swirl injector 5, adjustable on the axis of duct towards airflow with different distances ($L_v = 600, 350, 175$ mm) from flame holder. Angle of the atomization of injector - $90 \pm 5^\circ$ at the pressure fuel/propellant 40 atm(abs.).

The temperature of combustible mixture in front of the stabilizer of flame during tests remained the constant, equal to 973°K . The speed of flow changed in the range 70-150 m/s. Air of the stabilizing jet was preheated in a heat exchanger before temperature of 520°K . In the main line of the supply of this air, is establish/installated the injector for feeding kerosene, which makes it possible to change the composition of mixture over a wide range (during tests $\alpha_v = \infty \div 0,4$).

Gas-dynamic flame holder 6 (Fig. 1) has the following geometric

parameters: the diameter of tube 22 mm, the width of slot 0.8 mm, the angle of the blowing-in of jet of 135°. Sampling for gas analysis from the zone of return currents was conducted through cooled probe 7. Sample/tests were analyzed to the carbon-dioxide content and oxygen.

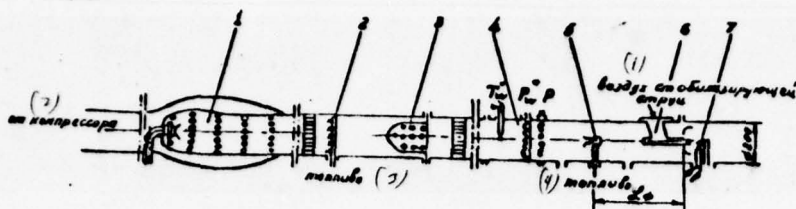

Fig. 1. Installation diagram.

Key: (1). Air which stabilizes jet. (2). From compressor. (3). fuel/propellant. (4). fuel/propellant.

Page 125.

The temperature of gases in the zone of return currents was measured by the platinum-platinum-rhodium thermocouple with antenna joint, fasten/strengthened to probe 7.

The limits of smooth burning were remove/taken in the assigned conditions/mode by of decrease or increase (the "lean" or "rich" region of combustion) in the feed of fuel/propellant into flow to complete flameout after stabilizer. In preseparation conditions/modes (0.9-0.95 from maximum impoverishment or enrichment) was measured the temperature and the composition of gas in the zone of return currents.

The calculations, carried out according to the procedure of K. N. Yerastov [2], show that the injected kerosene for the temperatures accepted and the speeds of flow and the selected distances L_ϕ evaporates to 75-95%. The evaluation of the trajectories of drops shows that the large/coarse drops ($d > 60 \mu$) do not fall into the zone of circulation, but they burn directly in flame front. This gives grounds with certain approach/approximation to count the combustible mixture, flowing to flame holder, to uniform in phase, but with the heterogeneous in section composition of mixture.

Results of investigation.

Figure 2 depicts the maximum excess air ratios of uniform and heterogeneous combustible mixture depending on the excess air ratio of jet of constants to temperature and speed of flow and the constant hydrodynamic parameter

$$\bar{q}_v = \frac{\rho_v V^2}{\rho_w W^2},$$

where V, W - jet velocity and flow;

ρ_v, ρ_w - density of jet and flow.

Both for uniform ones and heterogeneous ones in composition of mixtures during the enrichment of the stabilizing jet the limits of smooth burning are shift/sheared into the region of "lean" mixtures.

Extreme points in curves correspond to the left to the limits of the stabilization of flame on the jets of pure air. During the enrichment of jet by fuel/propellant the curves for different distances between the injector and the stabilizer (different heterogeneities) converge into two points. At these points in the flow of gas after preheating chamber, burns only the fuel/propellant, supplied to the stabilizing jet.

Page 126.

Flameout is achieved by impoverishment or enrichment of the composition of the mixture of the stabilizing jet. These are the modes of operation of the so-called gas-dynamic precombustion chamber.

The approach/approximation of injector to flame holder displaces the limits of smooth burning into region of more than "lean" mixtures, which is connected with an increase in the heterogeneity of combustible mixture in the section of the camera/chamber.

It is completely obvious that the limits of the stabilization of flame, designed by the average/mean composition of mixture in heterogeneous in composition flows, will depend not only on the distance between injector and flame holder, but also from the characteristics of injector (angle of atomization, the quality of its production), of size/dimensions of experimental section, etc.

Everything enumerated does not make it possible to obtain sufficiently general laws during the study of the limits of combustion in heterogeneous mixtures in the usually adopted coordinates $\alpha_w^0 = f(\alpha_v^0)$.

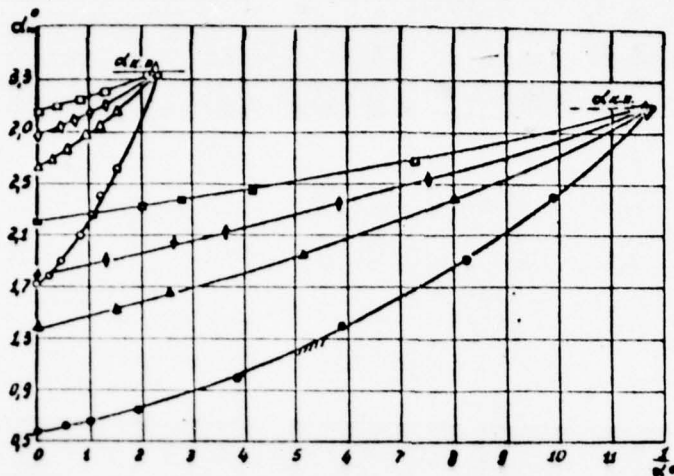

Fig. 2. limits of the stabilization of the flame: $\bar{q}_w = 25,0$; $W = 115$ m/s; $\infty - L_0 = \infty$ (uniform mixture); Δ - 600 mm; \diamond - 350 mm; \circ - 175 mm.

Page 127.

Figure 3 depicts those measured by the gas analysis of the field of the excess air ratios pered, by flame holder under conditions, close to separation ones (Fig. 2), when $\alpha_v^0 = \infty$ (pure air).

It is evident that combustible mixture in the center of overenrichment and the more powerful, than nearer is arrange/located injector to stabilizer. Since about stabilizer flows only the part of the flow near the axis of duct, then it is possible to assume that

the flameout will be determined from the mid section, but by the local excess air ratios in the zone of circulation.

Figures 4 and 5 depict the results of the measurements of the local excess air ratios $\alpha_{\text{TOT}}^{\circ}$ and of temperatures of gas T_{TOT} in the zone of return currents under conditions close to separation ones (Fig. 2).

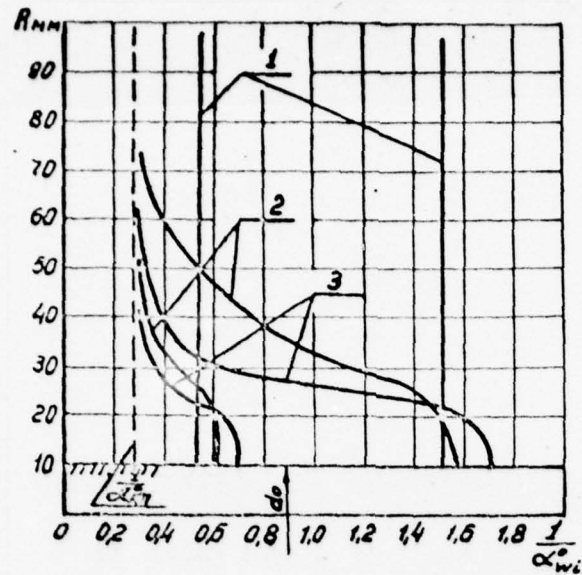

Fig. 3. Fuel distribution before the gas-dynamic (jet-edge) flame holder in the pre-separation conditions/modes: 1 - uniform mixture; 2 - $L_p = 600$ mm pressure fuel/propellant 8 and 22 atm (abs.) respectively; 3 - $L_p = 350$ mm pressure fuel/propellant 5 and 14.5 atm (abs.) respectively.

Page 128.

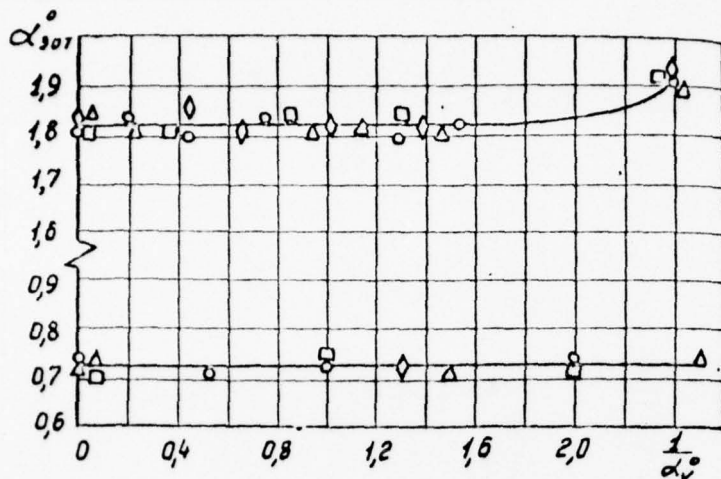

Fig. 4. Compositions of mixture in zone of return currents (zone of circulation) under conditions, close to separation ones:

$\bar{a}_0 = 25,0$; $w = 115 \text{ m/s}$; $\sigma - L_0 = \infty$; -600 mm ; -350 mm ; $\square -175 \text{ mm}$.

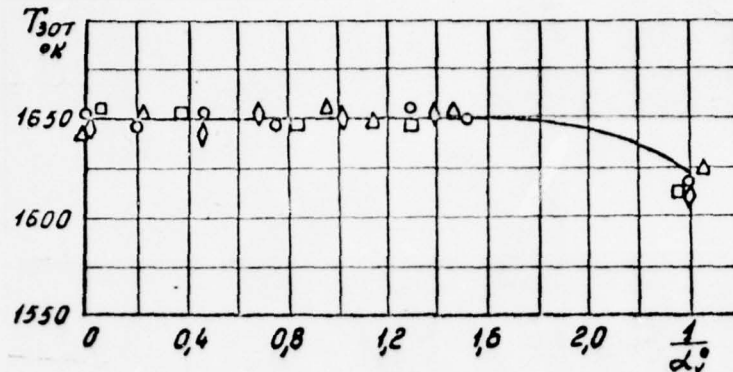

Fig. 5. Temperatures of combustion products under conditions, close to separation ones, in the "lean" region of the combustion:

$\bar{q}_v = 25,0$; $w = 115$ m/s; $\circ - L_2 = \infty$; $\Delta - 600$ mm; $\diamond - 350$ mm and $\square - 175$ mm.

Page 129.

Is obtained interesting result - with the preservation/retention/maintaining of the constant hydrodynamic parameter \bar{q}_v the flameout always begins with the constant excess air ratio (and, correspondingly, to the constant temperature of gases) in the zone of return currents regardless of the fact, with what degree of heterogeneity the combustible mixture attacks to flame holder and by the mixture of what composition is stabilized flame. This is explained by the fact that at the constant hydrodynamic parameter \bar{q}_v the size/dimensions of zone, return currents and zone of circulation, and also field of velocities, pressures, temperatures in

all pre-separation conditions/modes remained in effect constant [3]. Because of this the available time of the flow of gas in the zone of circulation was constant, therefore, was constant in maximum conditions/modes and the equal to it delay time of inflammation, depending unambiguously on the temperature of the igniting gases (composition of mixture) in zone. On the basis of this during the investigations of the stabilization of flame in the flow of uniform mixture, the excess air ratio in the zone of circulation is taken as the determining parameter [4].

In uniform flows [3] the length of the zone of return currents and diameter are the functions of the design (β_0, β_0, d_0) and regime (\bar{q}_v, θ) parameters

$$L_{30T} \sim D_{30T} = (\kappa_1 d_0 + \kappa_2 \beta_0 \bar{q}_v^n) \theta^m.$$

Assuming that in the first approximation, the size/dimensions of the zone of return currents (zone of circulation) substantially do not depend on the homogeneity of the composition of mixture by the section before the stabilizer (which is indirectly confirmed by constancy α_{30T}^0 and τ_{30T} in pre-separation conditions/modes for the flows of uniform and heterogeneous mixture), it is possible to select, also, for heterogeneous in composition flows as the determining parameter the excess air ratio in the zone of circulation.

However, it is necessary to note that the considerable approach/approximation of injector to flame holder (less than 175 mm) leads for the selected regime parameters to an increase in the portion of the re-evaporated fuel/propellant, which, in turn, changes the limits of smooth burning after flame holder because of existence of phases.

Page 130.

For reliable provision selected d in the zone of circulation it is necessary to know, what part of the flow before the flame holder form/shapes this composition in the zone of circulation. In experiments in stable combustion behavior, was supplied to the flow before the stabilizer through the cooled probe aqueous solution NaCl . From the beginning of the dyeing/coloration of the zone of return currents, was determined the significant dimension of the region of flow (the "tube" of flow).

The analysis of the obtained results showed that with an increase in the hydrodynamic parameter \bar{q}_v , in the size/dimension of the slot of the blowing-in of the stabilizing jet δ_s , and also of turbulence level ξ the significant dimension of the "tube" of flow increases.

The chosen "tube" of the flow before the gas-dynamic flame holder is conveniently calculated with the aid of coefficient m_1 [4].

Utilizing simple dependences, we will obtain

$$F'_{m_1} = \frac{m_1 G_{rv}}{\gamma_w W} + F_0 + \frac{F_k K_3 G_0}{G_k} \left(1 - \frac{F_0}{F_k}\right), \quad (1)$$

where $m_1 = \frac{q_{rv}}{G_{rv}}$ - a mixing factor;

q_{rv} - quantity of gas of the flow, ejected by the stabilizing jet;

G_{rv} - quantity of gas of the stabilizing jet;

γ_w, W - weight density and speed of flow;

F_0 - area of the tube of gas-dynamic flame holder;

F_k - area of experimental section;

G_k - mass flow rate of gas through the experimental section;

K_3 - coefficient, depending on the turbulence level of flow and equal to 4-4.8 in the range $\varepsilon_{rp} = 5 \pm 10\%$;

G_c - value of mass exchange between the zone of circulation after the poorly streamlined body and the incident flow¹.

FOOTNOTE ¹. In the value of mass exchange, is accumulated at present considerable experimental material (T. A. Bovina, G. Winterfeld, E. L. Solokhin, B. A. Silant'yev, etc.). ENDFOOTNOTE.

Page 131.

The comparison conducted showed that the ratio of the measured "tube" of flow to that calculated by formula (1) is close to one (Fig. 6). Satisfactory agreement is obtained also during the comparison of the measured excess air ratio α in the zone of return currents with those designed by the averages α in the "tube" of flow and the known values of mixing factor m_1 and α_v^* .

Thus, knowing m_1 and the flow of the gas of jet G_{rv} , it is possible to calculate an area of the "tube" of flow and a quantity of gas, ejected from flow.

These investigations made it possible to establish that the mixing factor m^* , conditionally introduced for the calculations of local ones α in the zone of circulation, makes clear physical sense.

There is no doubt that dependence (1) can be utilized for the calculations of the stabilization of flame not only in heterogeneous ones in composition of mixture, but also in heterogeneous ones according to speed, temperature, degree of contamination and so forth flows.

Conclusions.

The approach/approximation of a fuel injector to flame holder (in particular to jet) increases the heterogeneity of fuel distribution according to the section of the camera/chamber and displaces the limits of smooth burning, designed by α_w^0 and α_v^0 , into the region of more than "lean" mixtures.

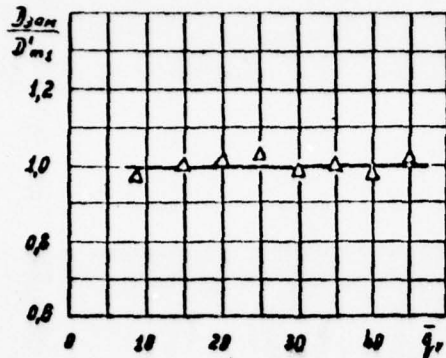

Fig. 6L

Page 132.

However, the characteristics of the disruption/separation of a similar form are not common/general/total ones, since they include the characteristics of injector. Therefore for the evaluation of the stabilization of flame in heterogeneous in composition of mixture flow as that being determining, one should take the excess air ratio in the zone of circulation (zone of return currents), forming as a result of cooperating the part of that encountering heterogeneous in composition of flow and jet in the general case of any variable composition.

In the case when it is possible to disregard the existence of phases of combustible mixture and to examine it only by heterogeneous

in composition, selected by that being determining the excess air ratio is numerically equal to the excess air ratio in preseparation conditions/modes in the zone of circulation after stabilizer in uniform on phase and composition of mixture flow.

Is determined the region of the flow before the flame holder, which forms the excess air ratio in the zone of circulation, and is proposed the method of its calculation.

REFERENCES.

1. Д у н с к и й В. Ф. Исследование механизма стабилизации пламени в следе за плохообтекаемым телом. Автореферат кандидатской диссертации. ЦИАМ, 1949.
2. Е р а с т о в К. Н. Исследование испарения капель топливного факела при высоких температурах газа. В сб.: Третье всесоюзное совещание по теории горения, т.2, 1960.
3. К о с т е р и н В. А., Х и с м а т у л л и н А. Я., Р ж е в с к и й Е. В. Некоторые вопросы газодинамики струй в поперечном потоке при горении. ИВУЗ, "Авиационная техника", 1966, № 1.
4. К о с т е р и н В. А. и др. Обобщение экспериментальных данных по пределам стабилизации пламени на струях. ИВУЗ, "Авиационная техника", 1968, № 3.

Received 12 February 1969.

Page 133.

STABILIZATION OF FLAME IN GAS-DYNAMIC PRECOMBUSTION CHAMBERS.

M. Sh. Gilyazov, V. A. Kosterin, P. K. Smorodin.

Are given the results of the experimental investigation of the stabilization of flame in gas-dynamic precombustion chambers in the flows of different speeds and temperatures. Are explained the special feature/peculiarities of the carburetion in zone of reciprocal velocities. Is made an attempt at the generalization of the obtained characteristics. Is proposed the method of calculation of separation limits according to the parameters of the incident flow and jet.

Gas-dynamic precombustion chamber is equipment/device for combusting the liquid or gaseous fuel in the high-speed airflow or mixture of air with combustion products. Its name it was called as a result of the fact that the zone of circulation, necessary in precombustion chambers for flame stabilization, is formed as a result of gas-dynamic interaction with the carrying flow of gas jet (fuel,

the oxidizer, for example, of air or their mixture), the supplied from housing precombustion chamber through the annular nozzle across the main flow. The schematic of gas-dynamic precombustion chamber is given in Fig. 1. Fuel/propellant for combustion is supplied with the stabilizing jet in the atomized and evaporated state or directly into the zone of circulation through arranged/located here injector [1].

Gas-dynamic precombustion chambers according to operating principle are the adjustable combustion chambers. Transverse size/dimensions them can be regulated by a change of feeding stabilizing gas.

Page 134.

Gas-dynamic precombustion chambers it is expedient to utilize for heating of gas in afterburners turbojet and bypass engines. They can also be applied as the adjustable camera/chambers for the preheating of cold air during the two-stage process of combustion.

In this article are given the results of the experimental investigation of the stabilization of flame in gas-dynamic precombustion chambers. Are given stalling characteristics with different size/dimensions of precombustion chamber in the flows of different speeds and temperatures. Are explained the special

feature/peculiarities of carburation in the zone of reciprocal velocities. Is made an attempt at the generalization of the obtained characteristics and development of the method of calculation of separation limits.

Investigation was carried out on the precombustion chamber, establish/installed in the flow core of gas in the section/shear of the duct with a diameter of 200 mm.

Fuel/propellant (kerosene) into precombustion chamber was supplied in were heated to $330 \pm 10^\circ\text{C}$ compressed air through the jet-edge collector/receptacle, arrange/located in the cylindrical part of the housing of precombustion chamber. Heating compressed air was conducted in heat exchanger. As a result of the fact that into air was supplied a considerable quantity of fuel/propellant, for the best mixing of fuel/propellant with air and increase in the uniformity of mixture after collector/receptacle was establish/installed multiturn worm conveyor. Fuel-air mixture escape/ensued through the annular slot at angle of 135° to flow direction, forming gas curtain.

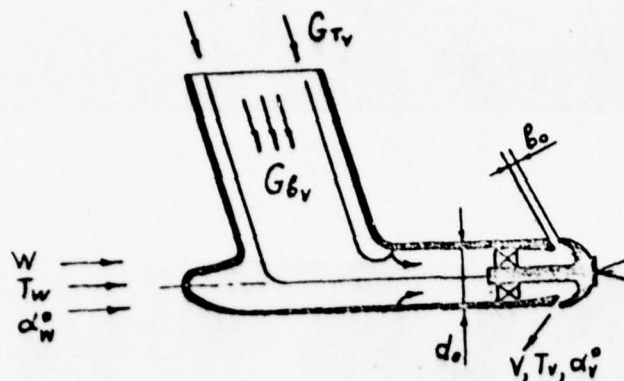

Fig. 1. Schematic of gas-dynamic precombustion chamber.

Page 135.

Stalling characteristics were removed/taken as follows. At given speeds, pressures and temperatures of flow and jet via of enrichment or leaning-out of mixture of jet, with the preservation/retention/maintaining of the remaining parameters constant/invariable, was achieved rich or lean flameout. Then precombustion chamber was started again. In preparation conditions/mode were measured the flow rates of air of high and low pressures and the parameters of flow and jet. Figure 2 gives separation limits according to the excess air ratio in jet α_v of the constant velocity coefficient of incident flow $\lambda_w = 0,18$, but different temperatures of flow and hydrodynamic parameters of jet $\bar{q}_v = \frac{\rho_v V^2}{\rho_w W^2}$. The character of a change in the separation limits with others λ_w (from

0.14 to 0.55) is analogous given. From curve/graph it is evident that the separation boundaries during an increase in the hydrodynamic parameter are displaced to the side of richer mixtures. With an increase in the temperature of flow T_w , on the contrary, they are displaced to the side of lean mixtures.

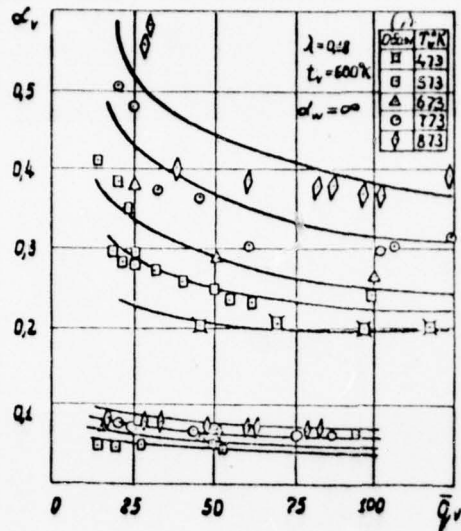

Fig. 2. Separation limits according to the excess air ratio in jet α_v of the velocity coefficient of incident flow $\lambda_w = 0,18$

Key: (1). illegible.

Page 136.

The mechanism of the stabilization of flame on the jet-edge screens, the excess air ratio of which is identical or insignificantly differs from the excess air ratio of the incident flow, is studied in sufficient detail [2, 3]. In the first approximation, it is possible to count that in gas-dynamic precombustion chamber the mechanism of the stabilization of the flame in principle of the same.

However, an essential difference between α_v in the jet and α_w flow in the case of gas-dynamic precombustion chamber introduces into the mechanism of the stabilization of flame a series of special feature/peculiarities. For example, the temperature of the gases, which ignite fresh mixture, is determined by the local composition of mixture, that are formed with the diffusion mixing of the jet, which contains a large quantity of fuel/propellant (evaporated and re-evaporated), with flow.

For the calculation of the local importance of the excess air ratio in the zone of mixing α_{m1} in work [4] is introduced coefficient m_1 , equal to the ratio/relation of the weight quantity of mixture, ejected by jet from flow q_w , the weight of gas of jet G_v .

Work [5] experimentally shows, that ejected by jet and the entering the zone of mixing quantity of gas q_w from the incident flow enters from the tube of flow with diameter D_{m1} . The gas, which takes place out of tube, does not fall into the zone of mixing and does not participate in shaping of local ones α in the zone of reciprocal velocities.

The comparison of the areas of tubes of flow before stabilizers

with the areas of the cupolas of gas-dynamic stabilizers or precombustion chambers in flows with approximately identical turbulent characteristics showed that the ratio/relations

$$A = \frac{F_{D_{m1}}}{F_K - F_{CT}} = \frac{D_{m1}^2}{D_K^2 - d_0^2}$$

remain constants with different ones $\bar{q}_w, \lambda_w, T_w$ (Fig. 3). Here D_K - diameter of cupola without combustion.

This result can be used for the construction of the simplified method of the calculation of mixing factors m_1 , and consequently, local α in the zone of the reciprocal velocities in precombustion chambers in the parameters of the incident flow and jet.

Page 137.

Mixing factor

$$m_1 = \frac{g_w}{G_v} = \frac{\rho_w W_0 F_{D_{m1}}}{\rho_v V_0 F_{KP}} q(\lambda_v) = \frac{\rho_w W_0}{\rho_v V_0} \cdot \frac{A D_K^2 \left(1 - \frac{d_0^2}{D_K^2}\right)}{4\mu \beta_0 d_0} q(\lambda_v).$$

The diameter of cupola is calculated from the parameters of the incident flow and jet [6]

$$D_K = d_0 + \kappa_1 \beta_0 \bar{q}_v^{0.49} \quad (\text{при } \beta_0 = 135^\circ; \kappa_1 = 16,0.$$

Key: (1). with.

After substitution D_κ and simple conversions, we will obtain

$$m_1 = A \sqrt{\frac{T_v^* \tau(\lambda_v) R_v}{T_w^* \tau(\lambda_w) R_w} \frac{1}{\bar{q}_v} \frac{(d_o + \kappa \beta_o \bar{q}_v^{0.43})^2}{4 \mu \beta_o d_o}} \left[1 - \frac{d_o^2}{(d_o + \kappa \beta_o \bar{q}_v^{0.43})^2} \right] q(\lambda_v).$$

Expression for m_1 is analogous with the dependence, obtained by I. B. Palatnik and D. Za. Temirbaev [7].

The excess air ratio in the zone of reciprocal velocities is calculated from known formula [3]

$$\alpha_{m_1}^o = \frac{m_1 \left(1 + \frac{1}{\alpha_v^o L_o} \right) + \left(1 + \frac{1}{\alpha_w^o L_o} \right)}{\frac{m_1}{\alpha_w^o} \left(1 + \frac{1}{\alpha_v^o L_o} \right) + \frac{1}{\alpha_v^o} \left(1 + \frac{1}{\alpha_w^o L_o} \right)}$$

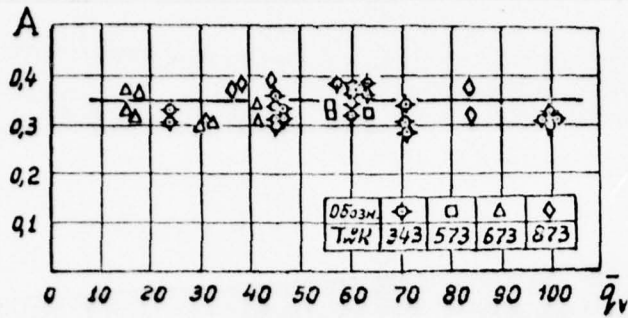

Fig. 3. Coefficient A of different ones \bar{q}_v and T_w

($\lambda_w = 0,14 - 0,21$)

Page 138

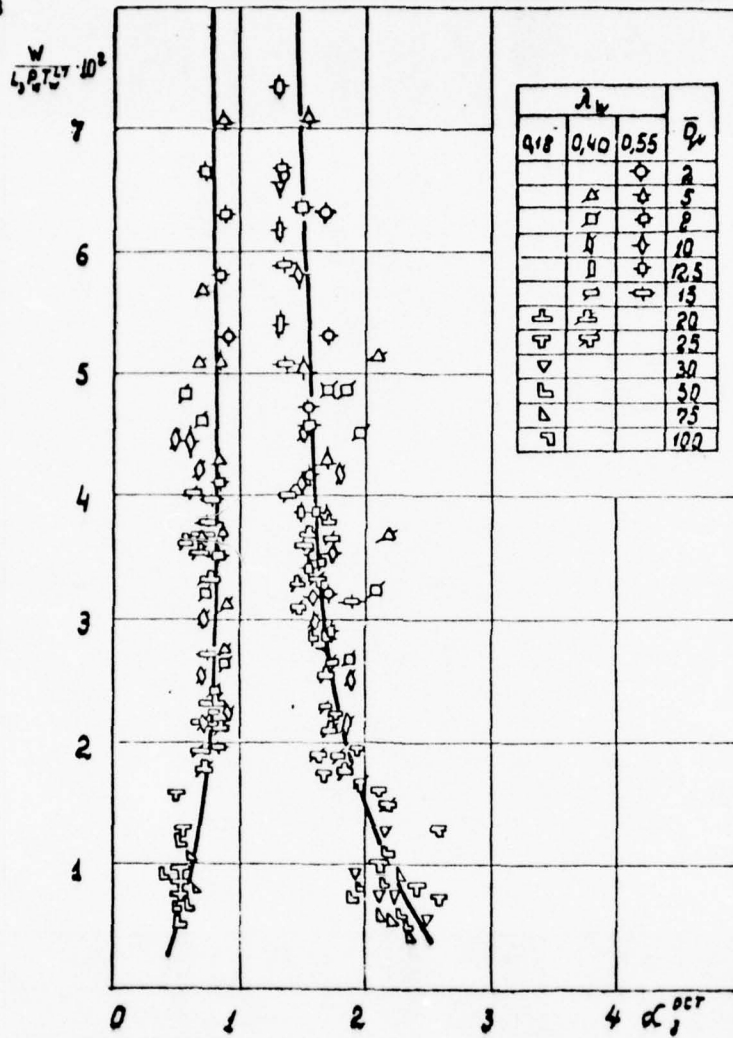

Fig. 4. Generalized dependence of separation limits of gas-dynamic precombustion chambers.

Page 139.

In Fig. 4 limits of the stabilization of the flame of gas-dynamic precombustion chambers, obtained at different temperatures, velocities of incident flow and in hydrodynamic parameters, are generalized in the form of dependence [8]

$$\frac{W}{L_3 P_w T_w^{1.7}} = f(\alpha_3^{OCT}).$$

The length of the zone of reciprocal velocities was calculated from the formulas of work [6].

Both "lean" and "rich" of the boundary of breakaway of flame satisfactorily they are generalized in the adopted coordinates (Fig. 4).

Utilizing the obtained generalized dependence and the proposed procedure of calculation of compositions, were designed separation limits by α_v (solid lines in Fig. 2). Calculated curves will agree sufficiently well with the data of experiments.

Conclusions.

1. Conducted experimental investigation of limits of smooth burning of gas-dynamic precombustion chambers.

2. Obtained analytical expression for calculation of mixing

factor in parameters of incident flow and jet.

3. Is given generalization of separation limits of gas-dynamic precombustion chambers from parameter

$$\frac{W}{L_3 P_w T_w^{1/2}} = f(\alpha_3^{\text{ост}}).$$

REFERENCES

1. З а с т е л а Д. К., К о с т е р и н В. А. и др. Способ стабилизации зоны горения в камерах горения воздушно-реактивных двигателей. Авторское свидетельство № 131162. Бюллетень изобретений комитета по делам изобретений и открытий при СМ СССР, 1960, № 16.

2. К о с т е р и н В. А., Х и с м а т у л л и н А. Я. Исследование механизма стабилизации пламени на газодинамических экранах. ИВУЗ, "Авиационная техника", 1967, юбилейный.

3. К о с т е р и н В. А. и др. Стабилизация пламени на струях и некоторые вопросы интенсификации горения смесей в потоке. ДГВ, т.5, № 3, 1969.

4. К о с т е р и н В. А. и др. Обобщение экспериментальных данных по пределам стабилизации пламени на струях. ИВУЗ, "Авиационная техника", 1968, № 3.

5. М о т и л и н с к и й И. П., К о с т е р и н В. А., А л е к с е е в Д. С. Особенности газодинамической (струйной) стабилизации пламени в потоке неоднородной (по составу) горючей смеси. Труды КИАИ (настоящий сборник).

6. К о с т е р и н В. А., Х и с м а т у л л и н А. Я. Влияние угла вдува на газодинамику вверных струй в сносящем потоке. Труды КИАИ, вып.101, 1968.

7. П а л а т н и к И. Б., Т е м и р б а е в Д. Ж. К расчету траектории осесимметричной струи в сносящем потоке. Теория и практика сжигания газа, № 4, 1968.

8. Ф р и д м а н Д. А., Б е н н е т В., Ц в и к В. Применение результатов научных исследований по вопросам горения к работе прямоточных двигателей. Вопросы горения и детонационных волн. Четвертый симпозиум (международный) по вопросам горения и детонационных волн. М., Оборонгиз, 1958.

DOC = 78204403

PAGE

~~14~~ 57

Received 20 April, 1970.

Page 141.

CALCULATION OF COMBUSTION CHAMBER WITH FLAME HOLDERS.

V. A. Kosterin, B. A. Rogozhin, V. T. Dudkin.

Is presented the method of calculation of direct-flow combustion chamber taking into account the flame holders of different types (poorly streamlined and jet-edge).

Are given examples of calculation and comparison with the results of experiment.

Heat supply to the driving/moving gas in flow, by limitation by walls, is typical for the combustion chambers of the air-breathing and compound engines.

Parameters of flow at the entrance into the camera/chamber and its transverse size/dimensions are defined during the calculation of the optimum thrust and economic engine characteristics taking into

account its make-up on flight vehicle and are assigned as initial data for calculation and planning.

Into the task of calculation, enters the determination of the position of flame edges, change in the pressure, temperature, speed and combustion efficiency of fuel/propellant along the length of the camera/chamber.

Question with the position of flame front in the driving/moving flow in pipe of constant cross-section during ignition from point source was examined in works [1-5]. It was assumed that the fresh mixture and combustion products are divided infinitely with the fine/thin flame front, in which abruptly are changed the parameters of gas.

Page 142.

For the final width of the zone of combustion, characteristic for real combustion chambers, the most complete and precise mathematical solution is obtained by A. V. Talantov [5, 7]. Analogously this same problem solves K. P. Vlasov. [8]. Difference, in essence, consists in the selection of the condition, closing solution for the calculation of the width of combustion zone.

All the available calculation methods are carried out for combustion chambers with point source of ignition. In real combustion chambers, for example, in ramjets and TRDF [~~TRDF~~ - turbojet engine with afterburner], the degree of blanket by flame holders reaches 40-50%.

In the set-forth method is considered the presence in the combustion chamber of flame holders and their effect on combustion characteristics.

By investigations in the intensity of turbulence during interaction of the carrying flow with mechanical and jet-edge flame holders [9] it is established/installed, that the intensity of turbulence in trace after flame holders reaches 40-100%. In the remaining region of the camera/chamber, is retained turbulence of incident flow (5-10%). With this sharp difference to turbulence levels and the mechanisms of combustion in different regions, probably, will be different [10]. In connection with this the mixture, which enters the camera/chamber, it is expedient to break on two parts. One part of the mixture with composition, in the general case different from the composition of the main flow, burns in "tube", (including and the high-temperature turbulent zone circulation), in trace after stabilizer it is calculated from the equations of chemical kinetics [11, 12]. Another part of the mixture

burns in "annular channel" around "tube" and is calculated from the equations of gas dynamics and combustion in the turbulent flow, analogous in work [6].

The separation of flow on two parts is conducted on the basis of the research of gas dynamics of interaction flame holder with flow [13].

Let us examine characteristic for engines cylindrical combustion chamber.

Page 143.

Besides the adopted assumptions in works [6, 7] about the unidimensionality of the incident flow at the entrance into the combustion zone and flow of the products of the complete combustion and about the constancy of static pressure over the cross section of the camera/chamber, are accepted still following:

1. The combustion of mixture occur/flow/lasts in the ne-communicated channels.

2. In central "tube" mixture burns behind flame front, perpendicular to axis of camera/chamber. This ^fflame front is

arrange/located in the section of the blowing-in of the stabilizing jet or in the section/shear of mechanical stabilizer.

In Figs 1, 2 represented the schematic of flow after jet-edge flame holder and the design diagram of the camera/chamber. In the known parameters of gas flow in section 0-0 for calculation, it is necessary to know the parameters of gas in section 1-1.

The diameter of "tube" in zone is taken equal to the diameter of the zone of circulation. For jet-edge flame holders, it can be calculated by the formulas:

$$D_{\text{TP}_3} = D_{34} = 0,78 \cdot \delta_0 \left(\frac{d_0}{\delta_0} + 15 \bar{q}_V^{0,49} \right) \cdot \theta^{*0,1} \quad (1) \quad \text{при } \beta_0 = 135^\circ;$$

Key: (1). with

$$D_{\text{TP}_3} = D_{34} = 0,78 \cdot \delta_0 \left(\frac{d_0}{\delta_0} + 12 \bar{q}_V^{0,49} \right) \cdot \theta^{*0,1} \quad (1) \quad \text{при } \beta_0 = 90^\circ.$$

Key: (1). with.



Fig. 1. Schematic of flow.

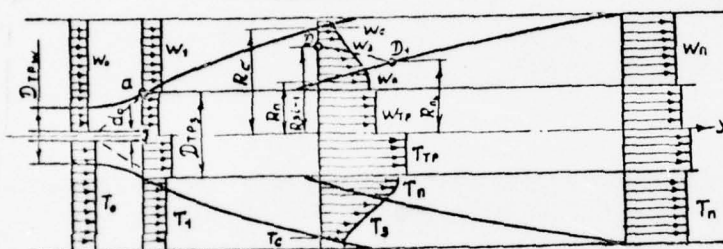

Fig. 2. Design diagram.

Page 144.

Here d_0 - diameter of the tube of jet-edge stabilizer;

b_0 - size/dimension of slot for the blowing-in of gas;

β_0 - angle of the blowing-in of gas;

$\bar{q}_v = \frac{\rho_v \cdot v^2}{\rho_w \cdot w^2}$ - ratio/relation of velocity heads of jet and flow;

$$\theta^* = 1 + \frac{H_u}{(1 + \alpha L_p) C_p T_w^*} - \text{degree of preheating.}$$

A quantity of gas, passing through the "tube", is determined from mixing factor m_1 for jet-edge stabilizers [14]. It is assumed that entire gas of jet and ejected by them gas from the part of the incident flow by size/dimension D_{TPW} they occur/flow/list through the "tube"

$$G_{r_{TPW}} = G_{r_V} m_1;$$

$$G_{r_{TP_3}} = G_{r_V} (m_1 + 1),$$

where G_{r_V} - a quantity of gas, supplied by the stabilizing jet.

In work [14] it is noted that the mixing factor m_1 depends in essence on the angle of the blowing-in of jet and little it changes over a wide range of a change of the regime and design parameters in combustion chamber. On the average it is possible to accept for $\beta_0 = 60^\circ - m_1 = 2.5$; $\beta_0 = 90^\circ - m_1 = 4.5$;

$$\beta_0 = 135^\circ - m_1 = 6.5.$$

During the stabilization of flame on the jets, the excess air ratio of which differs from the excess air ratio in flow $\alpha_{\text{ж}} \neq \alpha_{\text{w}}$, in "tube" it is form/shaped mixture with certain "average" α_{TP} . The excess air ratio in this case is determined by the excess air ratios in jet and in flow, and also by coefficient m_1 :

$$\alpha_{\text{TP}} = \frac{m_1 \left(1 + \frac{1}{\alpha_{\text{v}} L_0}\right) + \left(1 + \frac{1}{\alpha_{\text{w}} L_0}\right)}{\frac{m_1}{\alpha_{\text{w}}} \left(1 + \frac{1}{\alpha_{\text{v}} L_0}\right) + \frac{1}{\alpha_{\text{v}}} \left(1 + \frac{1}{\alpha_{\text{w}} L_0}\right)}$$

Thus, knowing coefficient m_1 can be determined G_{TPW} , $G_{\text{TPж}}$, α_{TP} and by the equation of continuity the diameter

$$D_{\text{TPW}} = \sqrt{\frac{4 m_1 G_{\text{rv}}}{\pi \gamma_0 W_0} + d_0^2},$$

where γ_0 and W_0 - specific gravity/weight and gas velocity in the incident flow.

For flame holders in the form of the poorly streamlined bodies, we take

$$D_{\text{TPж}} = D_{34} = K_2 D_{\text{стаб}}.$$

Coefficient K_2 is the function of size/dimension and form of stabilizer, degree of blanket. For stabilizers in the form of cone with apex angles of 30-60° and degree of blanket 10-30%, it is

possible to accept $K_2 = 1.30 - 1.22$ [13]

$$D_{TPW} = K_3 D_{CTO\delta}$$

Coefficient K_3 is the function of the same parameters, as K_2 . We take $K_3 = 0.8 - 1.0$.

From known ones D_{TPW} and D_{TP_3} are determined the parameters of gas flow in section 1-1.

The combustion efficiency of fuel/propellant in "tube" is calculated from the equation of chemical reaction rate [15]

$$-\frac{dC_T}{dt} = K_0 C_T^\nu C_{OK}^\mu T^{0.5} e^{-\frac{E}{RT}}$$

Page 146.

After a series of conversions, calculated equation for second-order reaction ($n = \nu + \mu = 2$) and half-angle of the expansion/disclosure of the flame front of 90° ($c = \text{ctg } 90^\circ = 0$) will take form [11, 12]

$$\tau = 1 - \frac{i}{1 + \alpha Z}$$

where $\alpha \cong \frac{t_{npe\delta}}{t_{xum}}$ - the first criterion of similarity of Dankohler [12];

$$z = \frac{x}{D_{TP_3}} - \text{axial nondimensional distance.}$$

Approximately criterion α can be estimated according to the equation

$$\alpha = \frac{K \cdot 0,232 \cdot \alpha L_0 \cdot T_{r_{cp}}^{0,5} \cdot e^{-\frac{E}{RT_{r_{cp}}}} \cdot P_1 \cdot L_K(D_{TP_3})}{R \cdot T_1 (\alpha L_0 + 1) W_{cpTP}}$$

where K - a constant; it is accepted equal to $1.4 \cdot 10^8 \text{ m}^3/\text{s} \cdot \text{kg}$;

α, L_0 - excess air ratio and stoichiometric coefficient;

T_1, P_1 - initial temperature and pressure;

R, R_1 - gas constants;

$L_K(D_{TP_3})$ - length (or diameter) of combustion chamber ("tube");

$T_{r_{cp}} = T_{eop_{max}} - \frac{RT_{r_{max}}^2}{E}$ - conditional temperature, at which burns the bulk of fuel/propellant [15];

E - activation energy;

$W_{cp,TP}$ - average speed of the motion of mixture along "tube".

Knowing combustion efficiency, it is possible to calculate speed, temperature and pressure gas along the length of cylindrical "tube" according to known from gas dynamics methods (for example [16]).

Page 147.

For the calculation of the parameters in "annular channel" we utilize the following equations:

1. The equation of conservation of mass for entire flow

$$\rho_i \cdot W_i (F_0 - F_{TP}) = \rho_c \cdot W_c (F_0 - F_c) + \int_{F_n}^{F_c} \rho_s \cdot W_s dF + \rho_n \cdot W_n (F_n - F_{TP}), \quad (1)$$

where F_0 - combustion chamber area;

F_c - total sectional area of the flow of the products of combustion, zone of combustion of "tube";

F_n - total sectional area of combustion products and "tube";

F_{TP} - sectional area of "tube".

Here and subsequently index 0 is related to the parameters in the undisturbed flow, 1 - to the parameters of the section where is formed flame front, C - fresh mixture, P - combustion products, TR - tube.

In order to present equations in more convenient dimensionless form, let us introduce the following designations:

$$u = \frac{W}{W_1}; \quad \tau = \frac{T}{T_1}; \quad \pi = \frac{P}{P_1}; \quad \eta = \frac{R}{R_0}; \quad \eta_{TP} = \frac{R_{TP}}{R_0}; \quad \bar{\Delta x} = \frac{\Delta x}{R_0}.$$

For that, in order to equation (1) and following, into which enter the integrals, they became algebraic ones, we consider the laws of a change in the speed and temperature in zone the known ones

$$u_3 = \frac{W_3}{W_1} = f(\eta) \quad \text{and} \quad \tau_3 = \frac{T_3}{T_1} = f(\eta).$$

← The real law of a change in these values is complex [7, 8] and has characteristic for the turbulent flames S - figurative form. With its sufficient accuracy can be approximated as linear relatively η .

Page 148.

Speed and temperature for this case will be written [7]

$$\tau_3 = \frac{\tau_n - \tau_c}{\tau_c - \tau_n} (A_1 - \eta); \quad u_3 = \frac{u_n - u_c}{\tau_c - \tau_n} (A_2 - \eta),$$

where

$$A_1 = \frac{\tau_n \tau_c - \tau_c \tau_n}{\tau_n - \tau_c}; \quad A_2 = \frac{u_n \tau_c - u_c \tau_n}{u_n - u_c}.$$

After the conversions and the solution of integral, we will obtain the final form of equation (1)

$$1 - \eta_{TP}^2 = \frac{\tau_c}{\tau_n} u_c (1 - \eta_c^2) + \frac{\tau_c}{\tau_n} u_n (\eta_n^2 - \eta_{TP}^2) + 2\tau_c \frac{u_n - u_c}{\tau_n - \tau_c} \times \\ \times \left[\frac{1}{2} (\eta_c^2 - \eta_n^2) - (A_2 - A_1) (\tau_c - \tau_n) + A_1 (A_2 - A_1) \ln \theta \right]. \quad (1)$$

Here are further $\theta = 1 + \frac{q}{c_p \cdot T_1}$; q - quantity of heat, conducted to one kilogram of gas.

2. Equation of momentum

$$P_1 (F_0 - F_{TP}) + \rho_1 W_1^2 (F_0 - F_{TP}) = P_x (F_0 - F_{TP}) + \rho_c W_c^2 (F_0 - F_c) + \\ + \rho_n W_n^2 (F_n - F_{TP}) + \int_{F_n}^{F_c} \rho_3 W_3^2 dF, \quad (2)$$

or, with analogous to equation (1) by conversions, we will obtain

$$\begin{aligned}
 (1 - \gamma_{TP}^2) \left(1 + \frac{1 - \gamma_c}{\kappa M^2}\right) &= \frac{\gamma_c}{\gamma_c} u_c^2 (1 - \gamma_c^2) + u_n^2 (\gamma_n^2 - \gamma_{TP}^2) \frac{\gamma_c}{\gamma_n} - \\
 &- \frac{2\gamma_c (u_n - u_c)^2}{(\gamma_n - \gamma_c)(\gamma_c - \gamma_n)} \left[\frac{1}{3} (\gamma_c^3 - \gamma_n^3) - (A_2 - \frac{1}{2} A_1) (\gamma_c^2 - \gamma_n^2) + \right. \\
 &\left. + (A_2 - A_1)^2 (\gamma_c - \gamma_n) - A_1 (A_2 - A_1)^2 \ln \theta \right].
 \end{aligned} \quad (2)$$

Page 149.

3. Equation of conservation of energy for flow of fresh mixture.
Flow we consider energy-isolated and adiabatic

$$C_p T_1 + \frac{W_1^2}{2} = C_p T_c + \frac{W_c^2}{2}. \quad (3)$$

We take $C_p = \text{const.}$ After which

$$\gamma_c = 1 - \frac{\kappa - 1}{2} M_1^2 (u_c^2 - 1). \quad (3)$$

4. Equation of adiabatic curve for fresh mixture

$$\frac{T_c}{T_1} = \left(\frac{P_c}{P_1}\right)^{\frac{\kappa - 1}{\kappa}}. \quad (4)$$

OR

$$\gamma_c = \gamma_c^{\frac{\kappa - 1}{\kappa}}. \quad (4')$$

5. Equation of conservation of mass of fresh mixture

$$\rho_{c_{i-1}} (F_0 - F_{c_{i-1}}) \cdot W_{c_{i-1}} = \rho_{c_i} W_{c_i} (F_0 - F_{c_i}) + \rho_{cp} u_T \Delta S, \quad (5)$$

where ρ_{cp} - average flux density of fresh mixture on section between sections i and $i-1$;

ΔS - frontal surface of flame between these sections;

u_T - flame velocity in turbulent flow. During calculation it is determined from data in work [7].

Page 150.

If we designate

$$\bar{u}_T = \frac{u_T}{W_i}, \quad \bar{\Delta S} = \frac{\Delta S}{F_0},$$

that we will obtain in a dimensionless form, after solving relative to distance along the axis:

$$\Delta \bar{X} = \sqrt{\frac{2 \left[\left(\frac{\eta_c}{c} \right)_{i-1} \cdot u_{c_{i-1}} (1 - \eta_{c_{i-1}}^2) - \left(\frac{\eta_c}{c} \right)_i \cdot u_{c_i} (1 - \eta_{c_i}^2) \right]}{\left[\left(\frac{\eta_c}{c} \right)_{i-1} + \left(\frac{\eta_c}{c} \right)_i \right] \cdot \bar{u}_T (\eta_{c_i} + \eta_{c_{i-1}})}}^2 - \frac{-(\eta_{c_i} - \eta_{c_{i-1}})^2}{2}} \quad (5')$$

6. Equation of conservation of energy for flow of combustion products. Taking into account the conducted/supplied to one kilogram of mixture heat in the process of the combustion

$$c_p T_1 + \frac{W_1^2}{2} + q = c_p T_n + \frac{W_n^2}{2} \quad (6)$$

Conversions, analogous to equation (3), will finally give

$$\tau_n = \theta - \frac{K-1}{2} M_1^2 (u_n^2 - 1) \quad (6')$$

7. Following method in work [6], let us write condition of equality required Δt_n and available Δt_p time for stream at output/yield from combustion zone (Fig. 2)

$$\Delta t_p = \frac{\Delta X}{W_{cp}}, \quad \Delta t_n = t_n - t_{3_{i-1}}, \quad (7)$$

where t_n - complete burn-up time of mixture in stream;

t_{3i-1} - retention time of mixture in combustion zone.

Page 151.

We take

$$W_{cp} = \frac{W_{3i-1} + W_{n_i}}{2} = \frac{1}{2} (u_{n_i} + u_{3i-1}) W_i.$$

Finally calculated equation we will obtain in the form

$$\eta_{3i-1} = \eta_{n_i} + \delta (\eta_{c_{i-1}} - \eta_{n_{i-1}}), \quad (7')$$

where

$$\delta = \frac{(u_{n_{i-1}} + u_{n_i}) \pm \sqrt{(u_{n_{i-1}} + u_{n_i})^2 - \frac{8R_0 \Delta x (u_{n_{i-1}} - u_{c_{i-1}})}{W_i t_n}}}{2(u_{n_{i-1}} - u_{c_{i-1}})}.$$

8. For determination of ordinate η_{3i-1} in (7') let us write equation of conservation of mass on output/yield from combustion zone for flow, limited by flow line DD_1 (Fig. 2)

$$\rho_{n_i} W_{n_i} (F_{n_i} - F_{TP}) = \rho_{n_{i-1}} W_{n_{i-1}} (F_{n_{i-1}} - F_{TP}) + \int_{F_{n_{i-1}}}^{F_{3i-1}} \rho_3 W_3 dF. \quad (8)$$

In a dimensionless form

$$\begin{aligned} \left(\frac{c_p}{c_n}\right)_i u_{n_i} (\eta_{n_i}^2 - \eta_{TP}^2) &= \left(\frac{c_p}{c_n}\right)_{i-1} u_{n_{i-1}} (\eta_{n_{i-1}}^2 - \eta_{TP}^2) + \\ + 2\pi \frac{u_{n_{i-1}} - u_{c_{i-1}}}{c_{n_{i-1}} - c_{c_{i-1}}} &\left[\frac{1}{2} (\eta_{c_{i-1}}^2 - \eta_{n_{i-1}}^2) - (A_2 - A_1) (\eta_{c_{i-1}} - \eta_{n_{i-1}}) + \right. \\ &\left. + A_1 (A_2 - A_1) \ln \frac{\eta_{n_{i-1}} - A_1}{\eta_{c_{i-1}} - A_1} \right]. \end{aligned} \quad (8')$$

Page 152.

9. Disregarding heat loss through walls, let us determine portion of isolated heat (burned down fuel/propellant)

$$\eta = \frac{\sum J_i - J_1}{\rho_1 W_1 (F_0 - F_{TP}) q}$$

In the expanded/scanned form

$$\begin{aligned} \eta &= \frac{1}{\rho_1 W_1 (F_0 - F_{TP}) q} \left[\rho_c W_c (F_0 - F_c) \left(c_p T_c + \frac{W_c^2}{2} \right) + \right. \\ &+ \rho_n W_n (F_n - F_{TP}) \left(c_p T_n + \frac{W_n^2}{2} \right) + \int_{F_n}^{F_c} \rho_s W_s \left(c_p T_s + \frac{W_s^2}{2} \right) dF - \\ &\left. - \rho_1 W_1 (F_0 - F_{TP}) \left(c_p T_1 + \frac{W_1^2}{2} \right) \right]. \end{aligned} \quad (9)$$

After substitutions and integrations we will obtain

$$\begin{aligned} \tau = & \frac{\bar{\alpha}}{(\theta-1)(1-\tau_{TP}^2)} \left\{ \left[\frac{u_c}{\tau_c} (1-\tau_c^2) + \frac{u_n}{\tau_n} (\tau_n^2 - \tau_{TP}^2) - \frac{1-\tau_{TP}^2}{\bar{\alpha}} \right] \times \right. \\ & \times \left(1 + \frac{\kappa-1}{2} M_1^2 \right) + \frac{u_n}{\tau_n} (\tau_n^2 - \tau_{TP}^2)(\theta-1) + \frac{1}{\tau_c} [(u_n \tau_c - u_c \tau_n) \times \\ & \times (\tau_c + \tau_n) - \frac{2}{3} (u_n - u_c) (\tau_c^2 + \tau_c \tau_n + \tau_n^2)] + \frac{\kappa-1}{2} M_1^2 \frac{u_n - u_c}{\tau_n - \tau_c} \times \\ & \left. \times [(\tau_c^2 - \tau_n^2) - 2(A_2 - A_1)(\tau_c - \tau_n) + 2A_1(A_2 - A_1) \ln \theta] \right\}. \quad (9') \end{aligned}$$

Page 153.

Just as in works [3, 6, 7], it is possible to write approximate relationship which escape/ensues from (3') and (6')

$$\frac{\tau_n}{\tau_c} = \theta. \quad (10)$$

Given equations (1)-(10) composes system of equations for the calculation of the position of flame and completeness of the burnout of fuel $(\bar{\alpha}, \tau_c, u_c, u_n, \tau_n, \tau_c, \tau_n, \Delta x, \tau_3, \tau)$ in the "annular channel" of stabilizer combustion chamber and they are suitable only for the calculation of middle section, i.e., where there is a fresh mixture, combustion zone and combustion products ($\tau_c < 1, \tau_n > \tau_{TP}$). For other sections will be obtained the particular solutions of these equations depending on the schematic of process. Let us point out the basic special feature/peculiarities which with certain by conversions will lead to calculated relationship/ratios.

Let us examine the initial section where not in one of the stream filaments it is reached complete burnout ($\eta_c < 1$, $\eta_n = \eta_{np}$).

In equations (1')-(10) it is necessary to make the following settings:

$$\eta_n = \eta_{np}; \quad u_n = u_{3_0}; \quad \tau_n = \tau_{3_0}; \quad \theta = \theta_{3_0},$$

where the mark "0" designates the parameters on the boundary of "tube" with "annular channel".

Condition (7) will be written more simply

$$\frac{2 \bar{\Delta X} \cdot R_0}{W_1 (u_{3_0, i-1} + u_{3_0, i})} = \frac{\theta_{3_0, i} - \theta_{3_0, i-1}}{\theta - 1} \cdot t_n. \quad (11)$$

Let us pass to final to the section where front/leading flame edge achieved wall ($\eta_c = 1$), a^{nt} mixture it burned down all ($\eta_n < 1$).

Page 154.

To more conveniently conduct the calculation of the parameters in combustion zone in wall (in equations 1', 2', 7', 8', 9')

$$u_c = u_{3c}; \quad \tau_c = \tau_{3c}.$$

Instead of disappeared equations (3), (4), (5) we record/write the equation of conservation of energy in zone at the wall (is analogous with equation (6)) and the condition of the equality of time (11) with the replacement of marks by "p" and "3_o" on "3_c", while instead of $\ln \theta$ in equations (1'), (2'), (9') to write $\ln \frac{\theta}{\theta_{3c}}$.

Approximate relationship/ratio (10) will take the form

$$\frac{\tau_{3c}}{\tau_n} = \frac{\theta_{3c}}{\theta}. \quad (12)$$

During the calculation of combustion in "circular" channel" can be encountered this case (for example, in below example in question), when, because of the high flame velocity in the turbulent flow u_f , to the large scale of turbulence l_0 (larger t_n), the considerable diameter of "tube", initial section is shortened and in middle section there will be only combustion zone (there are no fresh mixture and products of the complete combustion).

In this case the system of equations for initial and finite

segments will remain previous. For the calculation of middle section, it is necessary to bear in mind, that

$$\eta_c = 1; \quad \eta_n = \eta_{TP},$$

and also for the calculation of finite segment in the parameters with marks P to present marks β_0 and instead of C - β_c .

The calculation of "annular channel" one should fulfill, transfer/converting from one section to the next by successive approximations [7]. This course of computation makes it possible to calculate the heterogeneity in composition of mixture and parameters of turbulence over the section of the camera/chamber (caused, in particular, by the presence of flame holders) by changing the characteristics of combustion u_T and t_n from one section to the next.

After the determination of the parameters of gas in "circular" channel and "tube" the calculation can be refined, on the basis of the condition of the equality of static pressure for entire cross section of the camera/chamber.

Figure 3 depicts the results of the calculation of cylindrical combustion chamber with flame holders during the combustion of uniform kerosine-air mixture.

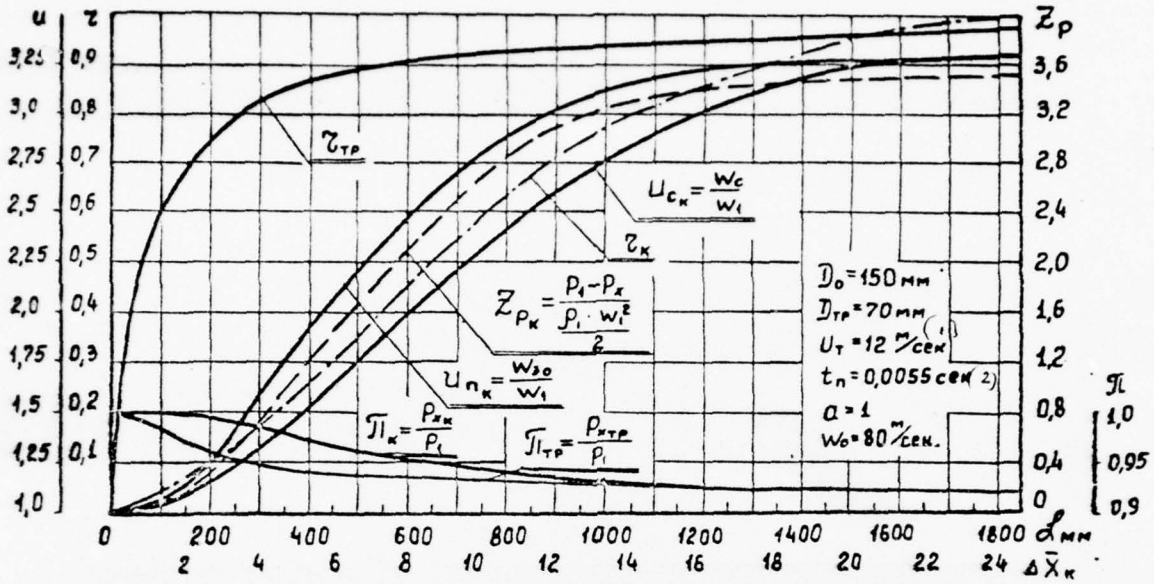

Fig. 3. Results of calculation of combustion chamber with flame holder.

Key: (1) . m/s. (2) . s.

Page 156.

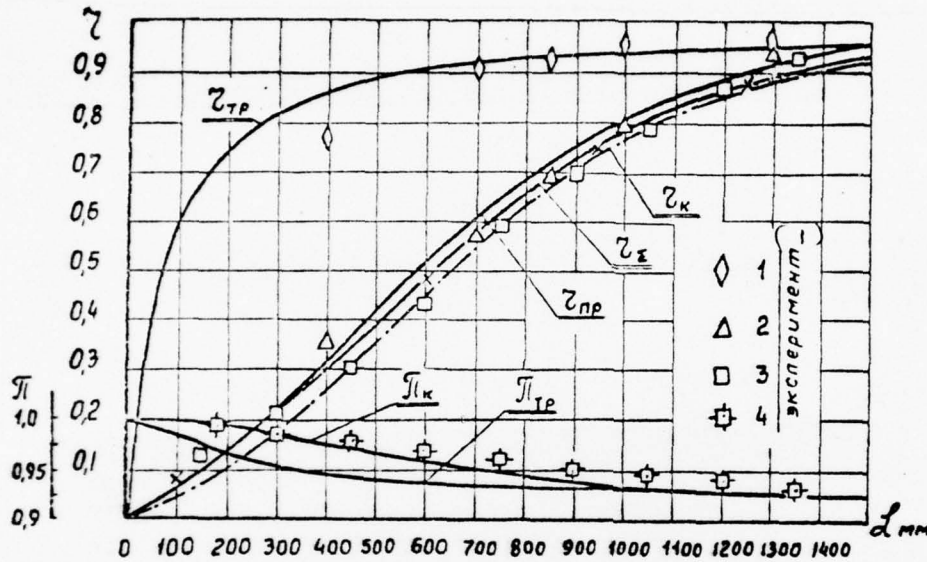

Fig. 4. Comparison of calculation and experimental data according to combustion efficiency of fuel/propellant: calculation - $u_r = 12$ m/s, $t_n = 0.0055$ s, $a=1$, $D_0=150$ mm, $D_{TP3} = 70$ mm; experiment - $T_w^* = 673^\circ K$; $\alpha_w = \alpha_v = 1.4$; $W_0 = 80$ m/s; $T_v^* = 523^\circ K$; $\bar{q}_v = 41$; $\beta_0 = 135^\circ$; $\delta_0 = 0.8$ mm. Combustion efficiency γ : according to the gas analysis: on axis - 1, over section - 2; with respect to a change in the static pressure - 3. Change in the static pressure on wall - 4.

Key: (1). experiment.

Page 157.

The satisfactory agreement of the results of calculation with experimental data according to the combustion efficiency of fuel/propellant (Fig. 4) makes it possible to judge the correctness of the proposed calculation method.

The combustion efficiency of fuel/propellant for entire section of the camera/chamber was summarized proportional to the mass flow rates of gas, flowing for "annular channel" and "tube"

$$\eta_{\Sigma} = \eta_{TP} \frac{G_{rTP}}{G_{r_0}} + \frac{G_{r_0} - G_{rTP}}{G_{r_0}} \quad (18)$$

Figure 5 shows the effect of the degree of the blanket of the area of combustion chamber by "tube" (by stabilizer), which confirms the need the account of flame holder during the calculation of the camera/chamber.

Figure 4 shows also the curve of combustion efficiency, calculated employing the approximate procedure ^(η_{TP}), which makes it possible to considerably lower the volume of calculated work, without leading in this case to significant errors.

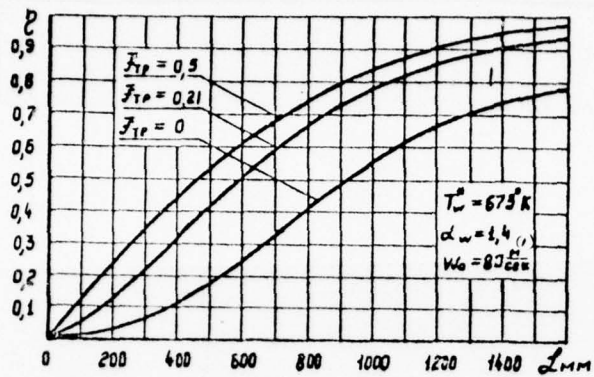

Fig. 5. Burnout of fuel along length of chamber with different dimensions of "tube" ($\bar{f} = \frac{F_{TIP}}{F_0}$):

$$\begin{aligned} \bar{f} = 0.21 & - \bar{q}_v = 41 \mid \alpha_v = 1.4; T_v^* = 523^\circ\text{K}; \alpha = 1; \\ \bar{f} = 0.50 & - \bar{q}_v = 90 \mid b_0 = 0.8 \text{ mm}; \beta_0 = 135^\circ; \\ \bar{f} = 0 & - \text{point source of ignition} \end{aligned}$$

Key: (1). m/s.

Page 158.

Supplementary suppositions during the composition of the approximate procedure consisted in following:

1. The front/leading and rear boundaries of combustion zone were located through known values u_T .
2. Values of speed and temperature over section of combustion zone were accepted by constant

$$u_3 = \frac{u_c + u_n}{2} \quad (1) \quad \text{и} \quad T_3 = \frac{T_c + T_n}{2}.$$

Key: (1). and.

Thus, the proposed method makes it possible to calculate cylindrical combustion chambers with the flame holders of different types (jet-edge and streamlined poorly).

REFERENCES

1. Зельдович Я. Б. Замечания о горении быстрого потока в трубе. ЖТФ, т.14, вып.3, 1944.
2. Вильямс Г., Хоттел Г., Скарлок А. Стабилизация и распространение пламени в газовом потоке большой скорости. "Вопросы горения", т.1, 1953.
3. Твян Г. Влияние формы пламени на скоростное поле потока. Вопросы ракетной техники, № 1(7). М., ИЛ, 1952.
4. Иида Г. Горение в турбулентных газовых потоках. Вопросы горения. М., 1963.
5. Черный Г. Г. Теоретическая гидромеханика. Сб. № 12 (вып.4). М., Оборонгиз, 1954.

6. Т а л а н т о в А. В. Основы расчета простейшей прямо-
точной камеры сгорания. ИВУЗ, "Авиационная техника", 1958, № 2.
7. И л ь я ш е н к о С. М., Т а л а н т о в А. В. Теория
и расчет прямоточных камер сгорания. М., "Машиностроение", 1964.
8. В л а с о в К. П. О расчете простейшей камеры сгорания
прямоточного типа. В сб.: Стабилизация пламени и развитие про-
цесса сгорания в турбулентном потоке. М., Оборонгиз, 1961.

Page 159

9. К о с т е р и н В. А. и др. Турбулентность в зоне
взаимодействия струй с потоком. Труды КИАИ, вып.110, 1969.
10. Д о р о ш е н к о В. Е. О процессе горения в камере
ГТД. Институт им. П.И.Баранова, Труды № 354, 1959.
11. К о с т е р и н В. А., Р о г о ж и н Б. А. Расчет вы-
горания за струйными стабилизаторами пламени. Труды КИАИ,
вып.98, 1969.
12. Miesse C.C. The Effect of Flame Configura-
tion on Combustor Performance. Combustion and
Flame, No5, 1961.
13. К о с т е р и н В. А., М о т ы л и н с к и й И. П.,
А л е к с е е в Д. С. Особенности газодинамической
(струйной) стабилизации пламени. Труды КИАИ (настоящий сборник).
14. К о с т е р и н В. А. и др. Обобщение эксперименталь-
ных данных по пределам стабилизации пламени на струях. ИВУЗ,
"Авиационная техника", 1968, № 3.
15. Щ е т и н к о в Е. С. Физика горения газов. М., "Наука",
1965.
16. М и х а й л о в А. И. и др. Рабочий процесс и расчет
камер сгорания газотурбинных двигателей. М., Оборонгиз, 1959.

Received 7 July 1969.

DISTRIBUTION LIST

DISTRIBUTION DIRECT TO RECIPIENT

<u>ORGANIZATION</u>	<u>MICROFICHE</u>	<u>ORGANIZATION</u>	<u>MICROFICHE</u>
A205 DMATC	1	E053 AF/INAKA	1
A210 DMAAC	2	E017 AF/RDXTR-W	1
B344 DIA/RDS-3C	9	E403 AFSC/INA	1
C043 USAMIIA	1	E404 AEDC	1
C509 BALLISTIC RES LABS	1	E408 AFWL	1
C510 AIR MOBILITY R&D LAB/FIO	1	E410 ADTC	1
C513 PICATINNY ARSENAL	1	FTD	
C535 AVIATION SYS COMD	1	CCN	1
C591 FSTC	5	ASD/FTD/NIIS	3
C619 MIA REDSTONE	1	NIA/PHS	1
D008 NISC	1	NIIS	2
H300 USAICE (USAREUR)	1		
P005 DOE	1		
P050 CIA/CRS/ADD/SD	1		
NAVORDSTA (50L)	1		
NASA/KSI	1		
AFIT/LD	1		
ILL/Code L-389	1		