

AD-A067 281

INSTITUTE FOR DEFENSE ANALYSES ARLINGTON VA SCIENCE A--ETC F/G 9/2  
TELEPROCESSING ISSUES IN THE DEPARTMENT OF DEFENSE. (U)

UNCLASSIFIED

JUN 75 J M AEIN, T C BARTEE, R A FINKLER DAHC15-73-C-0200  
IDA-S-445 IDA/HQ-74-16813 NL

1 of 3

AD  
A067 281



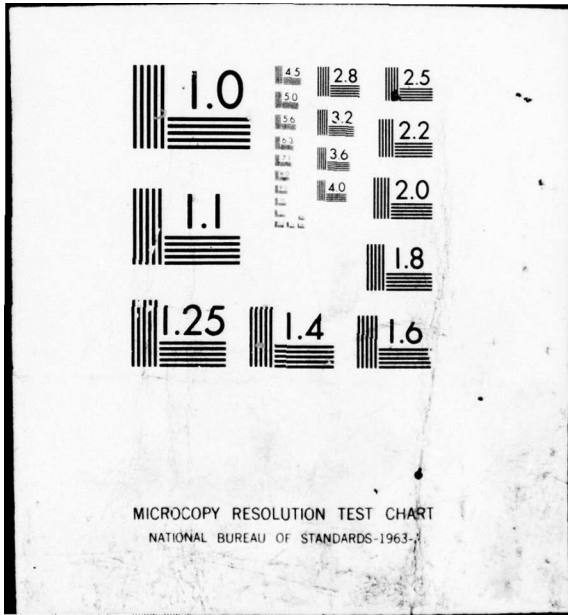

AD-E500 036

① LEVEL III

STUDY S-445

TELEPROCESSING ISSUES IN THE DEPARTMENT OF DEFENSE

Joseph M. Aein  
Thomas C. Bartee  
Ronald A. Finkler

June 1975

DDC  
RECEIVED  
MAR 2 1979  
B

INSTITUTE FOR DEFENSE ANALYSES  
SCIENCE AND TECHNOLOGY DIVISION

AD A0 67281

DDC FILE COPY



DISTRIBUTION STATEMENT A  
Approved for public release  
Distribution Unlimited

79 03 15 037

IDA Log No. HQ74-16813  
Copy 9 of 30 copies

The work reported in this document was conducted under contract DAHC15 73 C 0200 for the Department of Defense. The publication of this IDA Study does not indicate endorsement by the Department of Defense, nor should the contents be construed as reflecting the official position of that agency.

~~Distribution limited to U.S. Government agencies only; material subject to continuing policy discussion; November 1975. Other requests for this document must be referred to Assistant Director (Teleprocessing/ADP), Office of the Director, Telecommunications and Command and Control Systems (DTACCS).~~

Published May 1976

Approved for public release;  
distribution unlimited

STUDY S-445

TELEPROCESSING ISSUES IN THE  
DEPARTMENT OF DEFENSE

Joseph M. Aein  
Thomas C. Bartee  
Ronald A. Finkler

June 1975



INSTITUTE FOR DEFENSE ANALYSES  
SCIENCE AND TECHNOLOGY DIVISION  
400 Army-Navy Drive, Arlington, Virginia 22202

Contract DAHC15 73 C 0200

Teleprocessing

**DISTRIBUTION STATEMENT A**  
Approved for public release  
Distribution Unlimited

## CONTENTS

I. STUDY SUMMARY	1
A. Teleprocessing: A General Overview	3
B. DoD Teleprocessing Applications	7
C. Issue: Dedicated Versus Common-User Teleprocessing Networks	9
D. Issue: Current Teleprocessing Developmental Programs	15
E. Issue: Teleprocessing Network Standards	16
F. Issue: Multilevel Security	17
G. Issue: Network Switching	19
H. Issue: Teleprocessing Network Requirements and Analysis	21
II. INTRODUCTION	25
A. Background and Purpose	25
B. Approach	28
III. TELEPROCESSING APPLICATIONS	31
A. Application Types	31
B. Type I Needs	34
1. Type Ia Systems--Command and Control Nuclear Forces	35
2. Type Ib Systems--Crisis and Contingency Command and Control	39
C. Type II General Applications	46
1. Introduction	46
2. Discussion of Type II Applications	47
3. Merger of Existing Systems: A Case Study	50
4. Replacement with a New System: The Air Force SADPR-85 Base Level Computer Network Concept	52
5. Proposed AUTODIN II Network	68
6. Type II Sizing and Cost Model	79
D. Summary	86
IV. REQUIREMENTS AND ASSETS	91
A. Requirements	91
1. Acquisition Procedure for ADP Hardware	91
2. Discussion	93
B. ADP Asset Inventories	94
1. Computer Asset Lists	94
2. Functional System Inventories	101
3. Communications	103
C. Teleprocessing Systems	103
D. Summary	107

V.	DESIGN AND ARCHITECTURAL CONSIDERATIONS	109
A.	Design Topology and Analysis	110
1.	Topological Types	110
2.	Design and Analysis	116
B.	System Sharing	121
1.	Sharing Elements	121
2.	Sharing and Switching	122
C.	Network Design Problems	126
1.	Overview and ARPANET	127
2.	Flow Control	127
3.	Reliability/Survivability	129
4.	Packet/Circuit Switching Comparisons	130
5.	Access Performance	132
6.	Buffer Analysis	132
7.	Architecture and Performance Modeling	133
D.	Summary	134
VI.	COMPUTER AND DATA COMMUNICATIONS FUTURE ENVIRONMENT	137
A.	Communications	138
1.	Introduction	138
2.	Current Environment	138
3.	Future Environment	146
B.	Summary	154
VII.	SELECTED SYSTEM R&D ISSUES AND NEEDS	159
A.	Requirements, Activity Modeling, and System Evaluation	159
B.	Data Interface Standards	161
1.	Introduction	161
2.	Current Context	162
3.	ADCCP Example	164
4.	Network/Subscriber Interface	166
C.	Data Switching Techniques	169
1.	Background	169
2.	Packet Switching	171
3.	Circuit Switching	176
4.	Summary	177
D.	Network Control	179
E.	Multilevel Security for Data Transmission	181
F.	Network Interconnection	183
G.	Computer Science	184
H.	Summary	185

VIII. DOD DEVELOPMENTAL SYSTEMS AND STANDARDS	189
A. System Standards	190
B. Teleprocessing Systems Capabilities	191
1. Terminal Servicing--Interactive Systems	191
2. Data Base File Transfers	192
3. Remote Job Entry	193
4. Teleconferencing	193
C. Teleprocessing Systems Protocols	193
D. PWIN--The DoD Experimental Teleprocessing System	196
E. The ANMCC-NMCSSC Intercomputer Link	198
F. The AABNCP-SATIN IV/ANMCC Intercomputer Link	201
G. Development of Standard Software Packages	205
1. Data Base Management Systems	206
2. Standard Applications Programs	208
H. Summary	210
REFERENCES	213
APPENDIX A--Task Order	219
APPENDIX B--Automatic Data Processing Equipment Technology Forecast	221

RE: Classified references, distribution unlimited-  
No change per Mrs. Betty Pringle, IDA

ACCESSION for	
NTIS	White Section <input checked="" type="checkbox"/>
DDC	Buff Section <input type="checkbox"/>
UNANNOUNCED	<input type="checkbox"/>
JUSTIFICATION _____	
BY _____	
DISTRIBUTION AVAILABILITY CODES	
Dist.	or SPECIAL
<b>A</b>	

## ABBREVIATIONS

AABNCP	Advanced Airborne Command Post
ADCCP	Advanced Data Communication Control Procedure
ADL	Arthur D. Little, Inc.
ADP	automatic data processing; automated data processing
ADPE	automatic data processing equipment
AFRES	Air Force Reserve
AFSATCOM	Air Force satellite communications
AFSCS	Air Force Satellite Communications System
ANCC	Army Northeast Computer Center
ANG	Air National Guard
ANMCC	Alternate National Military Command Center
ANSI	American National Standards Institute
AREUR	U.S. Army, Europe
ARPA	Defense Advanced Research Projects Agency
ARPAC	Army Pacific Command
ARPANET	ARPA Network
ARS	Advanced Record System
ASC	Automatic Switching Center
AT&T	American Telephone and Telegraph Corporation
ATP	Automated Telecommunications Program
ATS	Automated Telecommunications System
AUTODIN	Automatic Digital Information Network
AUTOVON	Automatic Voice Network
BCP	Base Communications Processor
BLIS	Base Level Inquiry System
BTL	Bell Telephone Laboratories

C <sup>3</sup>	command, control, and communications
CAP	Communications Access Processor
CAPS	Configuration Analysis and Projection System
CCN	Command-Central Computer Network
CERs	Cost-Estimating Relationships
CINC	Commander in Chief
CINCEUR	Commander in Chief, Europe
CINCLANT	Commander in Chief, Atlantic
CINCPAC	Commander in Chief, Pacific
CINCSAC	Commander in Chief, Strategic Air Command
COM	computer output microfilm
ComSec	Communication Security
CONUS	Continental United States
CPE	Communications Processing Element
CPU	Central Processing Unit
CRT	cathode-ray tube
DBMS	Data Base Management System
DCA	Defense Communications Agency
DCS	Defense Communications System
DDD	Direct Distance Dialing
DDS	Digital Data System; Digital Data Service; data display subsystem
DoD	Department of Defense
DPP	Data Project Plan
DTACCS	Director, Telecommunications and Command and Control Systems, OSD
DUV	data under voice
EAM	Emergency Action Message
EMATS	Emergency Message Automatic Transmission System
ESD	Electronic Systems Division, AFSC
FCC	Federal Communications Commission
FMIS	Force Management Information System

FNPN	Front-end Network Processor
FORSTAT	Force Status and Identity Information Processing System
GEP	Ground Entry Point
GSA	General Services Administration
GTE	Ground terminal equipment
HCP	Headquarters Communications Processor
HIS	Honeywell Information System
IAS	Immediate Access Storage
IDN	Integrated Data Network, DCA
IMP	Interface Message Processor
I/O	input/output
IRS	Internal Revenue Service
JCS	Joint Chiefs of Staff
JCSAN	JCS Alerting Network
JOPS	Joint Operational Planning System
JTSA	Joint Technical Support Activity
JUMPS	Joint Uniform Military Personnel System
LSI	large-scale integration
MAC	Military Airlift Command
MACIMS	MAC Information Management System
MBCP	Message Base Communications Processor
MEECN	Minimum Essential Emergency Communications Network
MIH	manual information handling
MIS	Management Information System
MTMTS	Military Traffic Management and Terminal Service
MTS	Manual Telecommunications System

NASA	National Aeronautics and Space Administration
NCA	National Command Authorities
NDPSC	Navy Data Processing Service Center
NEACP	National Emergency Airborne Command Post
NIPS	National Information Processing System
NMCC	National Military Command Center
NMCS	National Military Command System
NMCSSC	National Military Command System Support Center
O&M	operations and maintenance
OSD	Office of the Secretary of Defense
OUH	operational use hours
PACAF	Pacific Air Forces
PACCS	Post-Attack Command and Control System, SAC
PACOM	Pacific Command
PCM	pulse code modulation
POL	petroleum, oil, and lubricants
PWIN	Prototype WWMCCS Intercomputer Network
RCP	Regional Communications Processor
R&D	research and development
REDCOM	Readiness Command
RFP	Request for Proposal
RJE	remote job entry
RJES	Remote Job Entry System
RNP	Remote Network Processor
RSB	Remote Support Base
SAC	Strategic Air Command
SADPR-85	Support of Air Force Automatic Data Processing Requirements Through the 1980s
SATCOM	Satellite Communications
SATIN IV	SAC Automated Total Information Network

SBS	Segment Binary Synchronous
SDIU	Subscriber's Digital Interface Unit
SDLG	Synchronous Data Link Control
SIOP	single integrated operational plan
SLFCS	Survivable Low-Frequency Communication System, SAC
STALOG	System to Automate Logistics at Base Level
TDMS	Time-shared Data Management System
TIPS	Terminal Interface Processor System
TS	time sharing
USAFE	U.S. Air Forces, Europe
UTE	user terminal equipment
VAN	Value Added Network
WAMTMS	Wide-Area Military Traffic Management and Terminal Service
WATS	Wide-Area Telecommunication Service
WIN	WMCCS Internet
WWDMS	Worldwide Data Management System
WMCCS	Worldwide Military Command and Control System

↓  
In October 1973, IDA undertook a

## I. STUDY SUMMARY

In October 1973, IDA was requested by the Office of the Assistant Secretary of Defense (Telecommunications)\* to undertake a task directed toward the development of a basis for evaluating the benefits that could result from managing computer communications at a teleprocessing system level as opposed to dealing separately at the computer and communication levels. Guidance was requested for the management, development, modification, and maintenance of teleprocessing systems to achieve potential improvements. Six major areas that influence teleprocessing were identified for consideration (Appendix A). The intent in identifying these areas was to give the study sufficient latitude to explore and develop initial guidance in those areas that appeared to be most fruitful and significant in a limited initial study phase consisting of 28 man-months of effort. It was not the intent of the task to deal with these six major areas in depth, nor could this study within this limited level of effort explore the justification of implementing teleprocessing systems within the DoD. (sent on p 2)

Within this limited scope, this study has raised more questions than it could adequately address. Little definitive experience with teleprocessing systems is available and analytic techniques are rudimentary with few quantitative data available on which to base analysis. As a result, most of the study effort was a data-gathering task to explore the current understandings of teleprocessing systems. However, this study has attempted to structure the questions and

\*This office has been redesignated as Director, Telecommunications and Command and Control Systems (DTACCS).

issues related to DoD applications of teleprocessing and to place teleprocessing in the larger context of industry developments and alternate approaches available for providing teleprocessing systems. In this context it has had to assume that the need for teleprocessing systems does exist within the DoD, initially in command and control applications, but there have been no assumptions as to the magnitude or time frame of that need.

The conclusions of this section are supported in part by the remainder of this study and in large part by the results of other referenced studies. Primarily, these conclusions are based on extrapolations from (1) the current experience with the DoD developmental teleprocessing systems (Section VIII)\*; (2) the few available studies regarding the economies of scale of large subscriber-oriented common-user data transmission networks (Section III); and (3) the foreseen developments in the computer industry and in the communication services provided by the Common and Special Carriers (Section VI). Significant cost factors used in the study were obtained from other referenced studies and no independent cost analyses or verification of the referenced cost analyses were conducted.

(cont'd)  
p 2

→ Teleprocessing is defined, for the purposes of this study, to be the set of functional capabilities provided by an integration of communications and data processing into a single cohesive system. The system applications of teleprocessing considered and identified by the study are: Type Ia (Command and Control of Nuclear Forces) and Type Ib (Nonnuclear Crisis and Contingency Command and Control) systems both of which provide informational support to the National Command Authorities; and Type II (General Data Processing Services) systems which provide data processing and computational services to administrative, support, and other DoD organizations. Both Type I and II systems are primarily fixed base information-handling systems, utilizing fixed plant communications, which are based typically on

\* Indicates references to sections of this study.

commercially available products although they may be modified or adapted to meet unique DoD requirements for reliability, survivability, or communication security. Type I systems may involve, in addition, mobile elements such as the Advanced Airborne Command Post (AABNCP) and other communication transmission media such as communication satellites. [Weapon control, tactical command and control and communication, and intelligence data-handling system applications are specifically excluded from consideration in this study.]

#### A. TELEPROCESSING: A GENERAL OVERVIEW

The capabilities potentially available from teleprocessing portend significant reductions in the cost (per function) and increases in the reliability of providing data processing and computational services to a multiplicity of users. These capabilities are based on networks of distributed data processing facilities supporting interactive computation, distributed data base query and response, and/or data base exchange and updating functions. Networks that provide teleprocessing functions imply the integration of communications and data processing which traditionally have been designed, developed, and procured by separate DoD organizations and have been provided by independent equipment manufacturers.

In the future, the traditional roles and interrelationships between communications and data processing can be changed radically by this integration. To guide the probable transition to greater use of teleprocessing within the DoD, parallel changes in management approaches and possible organizational changes are likely to be required.

The communication plant has evolved independently of data processing equipment as a human-oriented voice or narrative message interchange mechanism. The need for standards was limited to those necessary for compatibility among commonly procured equipment. Implicit in the design of the voice communication plant were the assumptions that (1) each subscriber should be capable of communicating

with any other subscriber and (2) the time of communication was relatively short and infrequent. This has led to the development of the present subscriber-oriented, common-user, switched telephone networks with the concept of achieving cost savings through the sharing of transmission and switching facilities (economies of scale). Similarly, the narrative message communication plant, to a large extent utilizing the transmission facilities of the telephone plant, has been based on (1) non-interactive one-way narrative communications between subscribers, (2) relatively short messages, and (3) message delivery times of tens of minutes to hours. This has resulted in the present communication-center-oriented, message-switching networks with economies of scale being achieved through centralized switching and shared transmission facilities (including those shared with the telephone plant) (Section VI-A).

The implicit extension of these assumptions and concepts as the "ultimate" approach to data communications for teleprocessing systems may not be technically necessary nor economically justified. Further, the complex interprocess logical relationships among data processing equipment, the operating and applications programs, and the remote data terminal equipment will strongly influence communication system design and standards and will require that approaches other than those above be considered.

In contrast to the "common-user" concept of communications, data processing systems have evolved as independent stand-alone "batch" systems or more recently as centralized "remote-job-entry" or "time-sharing" systems serving small communities of users with common purposes. This diversified approach has been fostered by the equipment manufacturers in the way they have designed and marketed their products. As a result, standards on data processing equipment, communication interfaces, and software interoperability only exist within a given manufacturer's product line or within a given user's system when special interoperability facilities have been developed. Information interchange standards applicable to different manufacturers'

equipment are limited to standard codes and their representation on various recording media or communication channels and have not been implemented on all equipments. Standards on software facilities, operating systems, "job control" languages, and data management systems are nonexistent except for certain programming languages (Sections VII-B and VIII-A and -G).

Therefore, a common-user teleprocessing network, utilizing data processing equipment and software from different manufacturers and truly transparent to the user, is not feasible unless a sufficiently large group of users enforce a common base of software development and equipment interoperability standardization.

While the current general communications environment is dominated by the characteristics of the existing analog telephony transmission plant and the tariff structure of the Common Carriers, new Specialized Carriers are being encouraged to offer communication services by a regulatory policy favorable to developing market competition. The Value Added Networks (VANs), a class of Specialized Carriers, are proceeding with development of subscriber-oriented common-user switched data networks based on adding special nodal computer-based switching facilities to dedicated transmission facilities leased from the Common Carriers. To varying degrees these networks are derived from ARPANET packet-switched technology. The principal immediate effect of the Specialized Carriers will be accelerated reductions in the tariff rate structure for data transmission as already manifest in the newly proposed AT&T Hi/Lo density tariff changes (Section VI-A).

Also, the introduction of the new AT&T leased point-to-point Digital Data Service (DDS) utilizing all digital T-1 local circuits and Data Under Voice (DUV) can be expected to further the trend toward restructured and reduced transmission costs. Of even greater significance would be the introduction of switching services (possibly logical or fast-circuit switching) on the DDS (the possibility of DDS switched service, while feasible, is purely speculative and there has been no formal indication by AT&T that the introduction of switched

service is planned). A switched DDS could provide a low-cost subscriber-oriented common-user data network of considerable geographic coverage and capacity that would have major impact on the general competitive evolution of the data communications market, user teleprocessing planning activities, and the development of both hardware and software technology (Section VI-A).

Overall, the future communications environment is thus characterized by uncertainty; the outcome of competing new types of service, their geographical extent, and the magnitude of the downward trend in communication transmission costs and tariffs cannot be predicted. Moreover, the possible future introduction by AT&T of switched service in the DDS could have a profound impact on the development of teleprocessing technology and on the decisions to implement dedicated versus common-user networks.

Finally, the major data processing equipment manufacturers perceive teleprocessing as a major new market area and are investing hundreds of millions of dollars in independently developing the equipment and software\* to support this capability. The smaller or specialized suppliers are paralleling these developments to maintain their competitive positions. In addition, comparable amounts are being invested in the new communication services,\*\* signaling a major expansion of the data communication plant. These developments, the industry pressures to rationalize interoperability requirements, and a renewal of the Federal Government's efforts (NBS and GSA) to establish standard peripheral equipment interfaces will guide the industrywide development of new processing, communication and terminal

---

\* IBM's "Advanced Function for Communications" and "Systems Network Architecture" for the 370 series computers and CDC's CYBER 170 series "Network Operating System" and "Network Communication System," for example.

\*\* AT&T's Digital Data Service and the various Value Added Networks and other Specialized Carriers.

equipment and standards, and will shape the form of data processing and communication systems available to the DoD for future implementations.

The magnitude of the commercial investments and the probable future DoD budget restrictions will result in DoD maximizing its use of these commercial products insofar as they can satisfy its teleprocessing requirements. To assure adequate consideration of its unique requirements and to minimize the extensive and recurring costs of modifying its future data processing systems to meet these requirements, DoD will probably have to actively participate in the development of industry data communication standards (much as it did for the COBOL standard).

#### B. DoD TELEPROCESSING APPLICATIONS

To provide a framework for considering teleprocessing system needs and issues within the DoD, this study has identified the major application areas as follows:

- Type Ia - Command and Control of Nuclear Forces
  - Ib - Nonnuclear Crisis and Contingency Command and Control
- Type II - General Data Processing Services

Type I applications are aimed at informational support of the National Command Authorities (NCA) and supporting commands with major support from the World Wide Military Command and Control System (WWMCCS). Type II applications, on the other hand, are diversified being oriented toward the provision of data processing and computational services to administrative, service, and other organizations within the DoD (Section III-A).

Type Ia applications must emphasize survivable connectivity between higher level command authorities and the nuclear-capable forces through the transattack period. Typically, there is a minimal volume of essential command data with assured, rapid, and secure delivery of

these data being the primary goal. Cost and economical operation tend to be secondary to these goals. Systems supporting this application area include SATIN IV (SAC Automated Total Information Network), the present and Advanced Airborne Command Post (AABNCP) aircraft, supporting communications (AFSATCOM, PACCS, MEECN, EMATS, and others), and other selected elements of the WWMCCS [the National Military Command System (NMCS)] that may survive (Section III-B).

Type Ib applications are characterized by intermittent large data processing and communication demands without a priori knowledge of where or when such capacity will be needed or specifically what data will be required. The major goal of these applications is the need to rapidly locate, correlate, process, and display quantities of data, geographically and organizationally distributed, for contingency planning and general-purpose force control. Survivability requirements are lower while communication and multilevel data\* security is a major concern and cost tends to be of equal concern. The WWMCCS is the primary system supporting this application with various specialized and common-user supporting communications. While the WWMCCS is not currently a teleprocessing system, various data communication programs such as the Prototype WWMCCS Intercomputer Network (PWIN), the WWMCCS Internet (WIN), and AUTODIN II are being considered or are in development for interconnecting the WWMCCS computer facilities (Section III-B).

Type II applications in the DoD are extremely varied and analogous to many commercial applications of teleprocessing such as Management Information Systems, Time Sharing, Remote Entry Service Bureaus, and others. In these applications, the overriding consideration is the economic delivery of data processing and computational services. Also in some systems security, both communication security (ComSec) and multilevel data security, may be major requirements. While few, if any, true Type II teleprocessing systems currently exist within the

---

\*The control of access by users of differing levels of clearance to a system (computer) containing data of various security levels.

DoD, every major service or joint reporting system is a potential candidate for the application of teleprocessing. Illustrative of the potential is the Air Force SADPR-85 Base Level Computer Network Concept, a possible future dedicated teleprocessing network intended to consolidate present Air Force Base Level ADP activities into 11 regional centers. The DCA proposed AUTODIN II (an upgraded replacement for the current AUTODIN, a store-and-forward narrative message switching system) is an example of a computer subscriber-oriented common-user switched data transmission system for supporting teleprocessing systems (Section III-C).

#### C. ISSUE: DEDICATED\* VERSUS COMMON-USER\*\* TELEPROCESSING NETWORKS

Because of differing requirements, the difficult-to-predict future technological and cost environment, and the lack of effective analytical tools and supporting data, there does not appear to be any "best" technical or cost-effectiveness approach to provide teleprocessing services to the various communities of users within the DoD. Type I applications will probably continue to develop along dedicated system lines because of their importance, time schedules, and unique requirements. Type II applications will probably be aggregated along several lines simultaneously: by organization (SADPR or MAC

---

\* A dedicated network implies a system that (1) is devoted (usually full time) to a well-defined set of functions serving a homogeneous group of users, (2) provides only fixed interconnections among users, and (3) is usually optimized or specialized (in equipment configuration, communications, processors, software, terminals, etc.) for the given purpose.

\*\* A common-user network implies a system that (1) serves (usually on demand) a heterogeneous group of users with varying functional requirements, (2) provides for arbitrary interconnections among users, and (3) usually must accommodate a wide variety of user equipment configurations and interface standards (communications, processors, software, terminals, etc.).

Information Management System), by geographical region (Navy Data Processing Service Center or Army Northeast Computer Center), or by standard application [Joint Uniform Military Personnel Systems (JUMPS)]. Data communications for both classes of applications may be provided either as a dedicated communication network (with some means of interconnection and interoperability) or as a part of a common-user network. The major considerations will be cost and the interoperability of the various data processing systems comprising a network (Sections III-B and -C).

1. Network "Economies of Scale"

A common-user data communication system with complete connectivity among all DoD users (Type I and II applications) may not be an attractive DoD approach for meeting its teleprocessing needs since it does not appear that the economies of scale persist to very large data communication systems. This is based in part on a comparison of an early DCA AUTODIN II study (Ref. 1), and the communication portion of the more recent Air Force SADPR study (Ref. 2), and in part on a study done for the Office of Telecommunications Policy (Ref. 3).\*

The AUTODIN II and SADPR networks proposed in the above studies are qualitatively similar in having comparable geographic coverage, high-speed communication trunks, and packet switching. The AUTODIN II (Section III-C-5) is by far the higher capacity system, being intended to interconnect 160 major computer sites while the SADPR communication system (Section III-C-4) is intended to interconnect 11 major Air Force computer sites. Using ten-year costs (leased circuit, switches on rental or tariff bases, and O&M costs) and neglecting communication security (ComSec) equipment and O&M costs, the average communication cost\*\* (for comparable capabilities) for both approaches is about \$650 thousand per major site per year (Table 7, page 78). When the costs of conventional communication security equipment and O&M are

\*The costs obtained from these studies have not been independently verified.

\*\* Total annual communication cost divided by the number of major ADP sites.

considered, the SADPR projected costs are \$1300 thousand per major site per year, and the AUTODIN II projected costs are \$800 thousand per major site per year. If the largest portion of the ComSec costs, the O&M costs, could be eliminated (on presumption that EATTON technology will be available) or shared with other O&M functions, there would not appear to be significant saving that could be attributed to economies of scale of the AUTODIN II over that of the SADPR communication system (Section III-C).

Further, in comparison with a centralized switching concept (such as AUTODIN II), data processing system centered data networks (as illustrated by SADPR) are attractive for several additional reasons. Essentially all communication distribution, switching, and control functions are performed at the data processing equipment site, reducing the need for separate switching facilities and providing a greater sharing of O&M costs among subsystem functions. Also, the whole teleprocessing system, excluding the ComSec equipment and communication transmission facilities, are under the control of the sponsoring organization making the system more responsive to user needs, providing greater assurance of compatibility and reducing procurement and O&M costs by greater use of the single computer supplier's equipment and software. In addition, the investment in the dedicated communication system need not be made until the data processing system is justified, procured, and installed, rather than to require the large initial investments in communication equipment and separate facilities implicit in providing a centrally switched common-user system prior to significant teleprocessing system implementations (Section III-C).

Finally, the study for the Office of Telecommunications Policy also indicates, based on a sizing and cost model, some of the factors influencing economies of scale. In one case, a highly centralized system serving the 50 major U.S. cities and providing primarily

message switching function with a small amount of remote batch operations, long-distance communication unit costs\* decreased almost linearly with increased load level but never exceeded 15 percent of total system cost. The total system unit costs were dominated by the central station and terminal, modem and local loop unit costs. In a second example, also a centralized system with similar geographic coverage providing comparable levels of message switching, inquiry, order entry and remote batch functions, communication unit costs dominated (40 percent of total unit costs) at low levels of transactions. At higher load levels, communication unit cost decreased to below 15 percent with central systems and terminals again dominating total system unit costs. A final example shows that at low load levels the communication unit costs of independent networks may be as much as six times greater than for a shared network of equal total level of output, and at higher load levels the communication unit costs are comparable, but in either case the unit costs are a small fraction (25 percent decreasing to 10 percent) of total system unit costs (Section III-C-6).

While the DCA AUTODIN II and SADPR cost estimates above are only illustrative and subject to further study and refinement, they and the OTP Study are indicative that data networks dedicated to a community of users may be a viable and economical alternative to a single large subscriber-oriented common-user data network. If inter-community communications are necessary, the adoption of compatible standards could permit the interoperability and exchange of information between these dedicated networks.

---

\* Cost per unit transaction (communications, processing, etc.).

CONCLUSION:

- (1) A viable alternative to a subscriber-oriented common-user data network, at least for an interim period, could be community-dedicated communication networks scaled to the requirements of a community of users and procured and implemented at the time the individual data processing systems are installed. Common provision of transmission facilities through DCA could still be used.
- (2) However, ComSec O&M costs appear to be a dominant factor which will weigh heavily against the use of smaller dedicated networks unless programs such as EATTON, intended to significantly reduce these costs, are implemented.

2. Data Processing System Interoperability

A deeper and more pervasive problem in the successful utilization of a common-user teleprocessing network arising from the experimental WWMCCS network experience is the problem of standard operating systems and support software (particularly data base management systems), and modular system-transferable applications software. Given the establishment of a communication link between a user and a remote data base in a different organization, unless the user knows the standards, the language, the means of operating the software, and the very meaning of the data elements, he cannot effectively obtain and utilize information. Thus a common-user teleprocessing network requires widespread information standardization if successful interchange is to be achieved. While such standardization is conceivable in the relatively small community of users such as WWMCCS, the extension to all potential data base systems that a (WWMCCS) user may need access to implies a level of data and software standardization across all major computer manufacturers' product lines that has never been achieved before. To achieve this level of standardization in the computer industry is difficult because there is little or no incentive for the manufacturers to be compatible with their competitors (Section VIII-G).

CONCLUSION:

Differences in manufacturers' software and user-defined application programs or data elements will limit the interoperability of teleprocessing systems and require major and costly standardization and modification programs to achieve compatibility.

3. A Suggested Interim Approach

From the foregoing, the establishment of a common-user teleprocessing network may not be economically attractive nor achievable in the next several years because of the difficulties of establishing operating system and service software standards. If necessary, DoD could identify, as an interim measure, major communities of users who must communicate and share data within each community to speed the development of requirements and the planning for system implementation. These communities might typically be the WWMCCS, the component command C&C systems, the intelligence community, the Services' management information systems, and others. These communities will often cut across conventional organizational lines (Section III-C).

CONCLUSION:

- (1) If this interim approach is considered, DoD should identify organizations to be responsible for commonality and/or interoperability of equipment and software, data base standardization, and the economic provision of data communication services within these communities.
- (2) Further, DoD should identify an organization responsible for coordinating these communities, particularly in the areas of standards and the provision of data communication services to minimize the potential interoperability problems if larger aggregations of users were to develop in the future.

#### D. ISSUE: CURRENT TELEPROCESSING DEVELOPMENTAL PROGRAMS

The current DoD developmental teleprocessing system programs\* provide indications of the types of problems that can occur in developing and implementing teleprocessing systems without appropriate intersystem standards and operating procedures. The difficulties that arise from establishing the interoperability of SATIN IV, the AABNCP, and the WWMCCS computers are caused in part by the differing interface and interprocess standards (protocols) and communication links used in the various systems. The PWIN experimental program for interconnecting the computers at JTSA, NMCSSC, and CINCLANT, and the program for transferring FORSTAT processing and updates have resulted in the need for significant modifications of the WWMCCS computer operating system and communication equipment and software. While some of these problems are magnified by the use of current teleprocessing technology, equipment and software, the impact (costs, implementation delays, equipment and software modifications, limited interoperability) on future attempts to interconnect different systems (particularly from different manufacturers with independently developed and specified data communication systems) will be extensive. These developmental programs are necessary to develop the experience and understanding of implementation problems necessary for future successful applications of teleprocessing within the DoD. Particularly, the assessment of the adequacy of current software approaches for supporting a computer-communication environment and of the adequacy of packet switching (ARPANET technology) in an operational command and control environment will be invaluable in future designs (Section VIII).

---

\*The interconnection of SATIN IV, the AABNCP, and the WWMCCS computers at the ANMCC and NMCSSC; the interconnection of the WWMCCS computers at the JTSA, NMCSSC, and CINCLANT through PWIN; and the interconnection of the WWMCCS computers at the ANMCC and NMCSSC for transferring FORSTAT processing and updates.

CONCLUSION:

- (1) Pursuit of these developmental programs, even though the interface standards and interprocess procedures established may be changed in the future, would help develop the experience and understanding necessary to the development of a better and more cohesive approach for teleprocessing within DoD.
- (2) While DoD should continue to cooperate with and encourage commercial standards groups as it has in the past, the urgency of the present developmental programs requires independent establishment of interim DoD standards as soon as possible.

E. ISSUE: TELEPROCESSING NETWORK STANDARDS

Typically, data communications for commercial teleprocessing systems represent 10 percent to 20 percent of total system cost. Of the remaining data processing costs, industry estimates indicate that 75 percent is for software (operating systems, supporting system programs, communication control, data base management, and applications programs). A significant portion of these costs, particularly in the new teleprocessing-oriented commercial computer systems, is for the unique software operating systems and communication control programs provided by the manufacturer with his equipment. This software is supported (upgraded, maintained, and corrected) by the manufacturer who is able to amortize the large development investments necessary over the large number of systems installed.

If the commercially available data processing systems are incompatible with DoD data communication equipment and standards, DoD must accept the burden of modifying and supporting the operating systems and communication control programs during a system's lifetime. A recent study (Ref. 4) indicates that the total current annual DoD software costs are exceeding \$3 billion and reported that other studies have indicated that an estimated 85 percent to 95 percent of the WWMCCS ADP costs are for software. For the

future, to minimize its development and O&M investments in equipment and software modification and maintenance, it would appear that DoD should consider adapting its requirements for teleprocessing systems to the developing industrywide system standards. However, these standards probably do not accommodate the unique DoD requirements for communication security (ComSec), access control, multilevel information (data base) security, system priority overrides to meet peak demand, system redundancy, and system survivability.

CONCLUSION:

- (1) For the future, DoD should consider adopting industry data communication standards to avoid the extensive and continuing additional costs of modifying commercial data processing systems to meet differing communication standards.
- (2) DoD should also consider actively fostering and participating in the development of industrywide data processing and data communication standards to provide the greatest availability of compatible and competitive equipment and software for future system implementations, to maximally utilize the very large industry investments (potentially hundreds of millions of dollars) in equipment and software, and to assure adequate consideration of unique DoD requirements.

F. ISSUE: MULTILEVEL SECURITY\*

Multilevel security is an essential element for DoD teleprocessing systems. There is currently no known method to provide "adequate" security for teleprocessing systems. Moreover, no rigorous method has been found acceptable for proof-testing secure teleprocessing systems. In such systems it is necessary to differentiate between subscriber host/computer security and security in

---

\*The control of access by users of differing levels of clearance to a system (computer) containing data of various security levels.

the switched data transmission facilities. Since transmission link security has been achieved and switching facilities utilize limited and specific computer functions which can be hardware compartmented and housed in secure facilities, it is reasonable to expect that switched data transmission security can be achieved. The provision of multilevel security for teleprocessing host computers is more difficult and further in the future. Research activities are under way with the virtual machine and security kernel being the most promising approaches being pursued (Section VII-E).

In the relationship between transmission security and subscriber host/computer security, it is obviously not sufficient to have one without the other or to overinvest in achieving one at the expense of the other. Even more fundamental is the likelihood that while security may be achieved for transmission and host sites individually, when they are interconnected in a teleprocessing network, security may not be assured. As a result, there is a need to develop methods to verify that in a teleprocessing network an adequate level of security has been achieved. It seems certain that new concepts of security and resulting doctrine will have to be evolved. Due to the fundamentally new features (technical, operational, and organizational) of teleprocessing systems, multilevel security requirements will have a major impact on the access that various users will have to certain systems and on systems design and implementation (Section VII-E).

CONCLUSION:

- (1) The development of solutions to the multilevel security problems and the establishment of new security procedures for teleprocessing systems should be pursued to assure that an "adequate" level of multilevel computer data security can be obtained and shown to exist when a multiplicity of systems are connected together in a network.

- (2) New security equipment and procedures are also required because the application of current approaches increases the costs to a level that the projected economies of teleprocessing systems are minimized or lost.

#### G. ISSUE: NETWORK SWITCHING

Comparisons between packet- and circuit-switching networks are a function of user characteristics, types of data (transmission, bulk), load level, and geographic distribution (as well as being sensitive to the technology, cost, and comparison measures chosen). The principal advantage of the packet technique derived from the ARPANET program resides in its flexible dynamic allocation of communication transmission trunks and potentially high utilization of overall network capacity on a nearly instantaneous demand basis. This technique is of particular advantage for interactive and data base query response teleprocessing applications. In addition, a multiplicity of dispersed switching locations utilizing packet switching with adaptive routing provides enhanced survivability of communications connectivity. However, packet switching does require standardized data interfaces since switching is a logical function performed within a computer-like device. Also, packet-switching network flow control with priority preempts, a major requirement in DoD data communication networks, is not well understood (Sections V-C and VII-C).

On the other hand, for bulk data transmission such as data base transfers and remote job entry, circuit switching has the advantage. Circuit switching is more efficient and much more flexible since once the switching function is performed, the circuit is completely transparent to the data stream. Also, preemption techniques and means of enhancing connectivity survivability are better understood based on the approaches used in the AUTOVON voice network (Sections V-C and VII-C).

However, a third alternative is to remove the switching from the communication network and provide dedicated trunks between data

processing sites and perform the switching in the processors. While this may increase the costs of communications if the dedicated trunks are not fully utilized, the introduction of concentrators for local access lines can provide dynamic sharing of the trunks which will realize the major portion of the savings on long-distance point-to-point transmissions cost. This approach does not provide the on-demand connectivity between arbitrary points (the forte of the common-user switched data network), but it can provide economical service for fixed connectivity systems if the trunks can be reasonably utilized. An extension of this concept to more fully utilize the trunks is a piggyback communications service that could be provided by a large geographically distributed teleprocessing system to smaller local systems with limited long-distance communication requirements (Sections V-B and -C).

#### CONCLUSION:

- (1) While both packet technology and circuit switching appear attractive, a hybrid packet and circuit-switch design may be the most desirable approach for segregating bulk data transmissions from transactional data interchanges, mitigating the access and flow control problem, and achieving flexible reconfiguration of the network to changes in user characteristics.
- (2) The use of a centralized processor (with its own communication processor) of a given system to concentrate and relay information or requests from its community of users to another system could minimize the requirements for a subscriber-oriented common-user switched data network.
- (3) Analysis is required to determine whether (1) a centralized switching concept such as AUTODIN II, or (2) a concept of distributed switching collocated with major data processing centers such as ARPANET, or (3) a data processing system centered data network using full-time dedicated trunks (with simple multiplexing/concentration for line sharing), or (4) an appropriate mix of these concepts, is the more economical.

#### H. ISSUE: TELEPROCESSING NETWORK REQUIREMENTS AND ANALYSIS

At present, teleprocessing requirements formulation is done on a system-by-system basis, a reasonable process compatible with upgrading present stand-alone systems but inadequate for any overview of aggregated teleprocessing requirements. However, as part of the DTACCS Internet Study (Ref. 5), a re-examination of the DoD candidate teleprocessing systems was conducted. This provided for the first time in DoD a common frame of reference for preparing teleprocessing system descriptions and requirements. Without such a requirements overview it is very difficult to assess the present status and projected teleprocessing needs nor make judgments as to priority of need. Functional ADP systems data also have been collected and aggregated by OASD (I&L) and were used in the DTACCS Internet Study (Section IV).

The current methods of analysis of data processing requirements are inadequate for teleprocessing systems because they tend to neglect the detailed interaction between data processing and communications, the communication-induced processing workloads, and the tradeoffs in types of equipment and allocations of processing among sites. As more comprehensive data are obtained describing user-oriented data processing requirements, it will be necessary to translate these needs into technical specifications of generic types of basic processor functions and relate these to the division of tasks among processor sites, to communications traffic loads, and to network organization. Mathematical models of user activity, computer functions, and data organization and traffic will have to be developed or refined (Sections V-A and VII-A).

In addition to the limitations of available design and analysis techniques, system costs are sensitive to the complex schedules of transmission tariffs and equipment charges developed within the context of current use of the telephone plant as a support element to computer centers. As such, the analysis is specialized by and the results limited to the particular configuration and operational

constraints of specific vertically integrated systems. Only recently, as an outgrowth of ARPANET, are analytical design tools being evolved that are applicable to the study of subscriber-oriented data networks (Section VII-A).

Network control design problems also exist. Only since the advent of the ARPANET, PWIN, AUTODIN II, and the interconnect on between SATIN IV and AABNCP has the magnitude of the network interconnection problem become apparent. Currently there is an inadequate understanding of the problems of flow control, overflow procedures, failure recovery, access and priority override control, and others. Also, it can be expected that future teleprocessing networks will develop a need to interconnect at least selectively at gateway locations. This will involve areas of additional technical complexity that include logical compatibility, message responsibility, control stability, fault recovery, and security. Commitments to major new operational teleprocessing systems should be based on a better understanding of these problems and their impact on network structure and requirements (Sections V-C and VII-D).

CONCLUSION:

- (1) Currently there is no one element within DoD formally charged with developing and maintaining a current and comprehensive computer system description and requirements data base including teleprocessing related data.
- (2) DoD needs to foster the development of more comprehensive methods of describing system requirements, and translating these requirements into technical specifications, as well as development of performance measures, network analytical methodologies, and sufficient data on patterns and demands of system usage.

Finally, the study team, in judging the results of this preliminary study, can only reiterate and strongly support the following conclusions of the 1970 Blue Ribbon Study.\*

The basic problem is that the present organizational assignment of responsibilities for ADP policy formulation, management and operation is inadequate to insure the most efficient and economical use of ADP either Department-wide, or within a Military Department or Defense Agency. The organizational level of policy responsibility within the Office of the Secretary of Defense (OSD) for ADP is too low to insure that required and desirable policy changes are made and implemented consistently throughout the Department. In addition, there is no single office charged with the responsibility for long-range planning to keep policy abreast of industry development, and to provide flexibility in Department policy to take advantage of evolving technological changes.

Present assignment of policy responsibility for ADP in OSD takes inadequate cognizance of the close technical and cost relationship of communications and ADP management. As a consequence, the interface between ADP and communications is inadequate, and will become increasingly inadequate as digital communications technology increases.

The remainder of this report discusses the following subjects:

- Section II--the background and approach used in the study
- Section III--the generic types of teleprocessing applications within DoD with a description of several current proposed, developmental, and experimental teleprocessing systems including SATIN IV, PWIN, SADPR-85, and AUTODIN II
- Section IV--data processing requirements and a summary of the current data processing assets of DoD

---

\* Report to The President and the Secretary of Defense on the Department of Defense, Blue Ribbon Defense Panel, 1 July 1970 (Washington, D.C.: U.S. Government Printing Office).

- Section V--design and architectural considerations of communication networks including network topology, system sharing, and common-user network design
- Section VI--the future communication environment including new transmission facilities and suppliers
- Section VII--selected system development issues and needs including analytical methodology, network interface standards, data switching, network control and interconnection
- Section VIII--some current developmental system experience and problems related to interface standards (protocols) and service and application programs (data base management, FORSTAT, etc.)
- Appendix B--a data processing technology forecast taken from the SADPR-85 study.

## II. INTRODUCTION

### A. BACKGROUND AND PURPOSE

In October 1973, IDA was requested by the Office of the Assistant Secretary of Defense (Telecommunications)\* to undertake a task directed toward the development of a basis for evaluating the benefits that could result from managing computer communications at a teleprocessing system level as opposed to dealing separately at the computer and communication levels. Guidance was requested for the management, development, modification, and maintenance of teleprocessing systems to achieve potential improvements. Six major areas influencing teleprocessing were identified for consideration (Appendix A).

ADP-related assets may be interconnected through a communications network (teleprocessing) to achieve new or augmented capabilities. The internetting of these assets provides a means of defining the benefits and management issues. As with the presently existing ADP systems there is not as yet and probably will not soon exist a unique set of management guidelines or quantitative ordering of benefits of various alternatives for managing the development of teleprocessing systems. The ADP technology is in a high state of flux (as usual) with an exceptionally dynamic and diverse market for application ranging from major system upgrades (e.g., adding remote terminals to established computer centers), to new capabilities to support established missions (e.g., interactive inquiry/response for real-time systems--operations scheduling, logistics, command and control, etc.) and potentially new

---

\* This office has been redesignated as Director, Telecommunications and Command and Control Systems (DTACCS).

systems creating new activities or heavily influencing current activities (e.g., distributed processing, personal processing, cashless society, etc.).

It was recognized early in the study that the subject of teleprocessing is exceptionally broad and complex with many faceted interactions and possible interfaces among suppliers, purchasers, and users within DoD and, even more generally, within the commercial world as a whole. With the limited resources available it was decided to focus primarily on the network issues. The approach taken was to consider the problems--technical, functional, and economic--associated with interconnecting computers and terminals through one or more communications networks (internetting). With the exception of data security and more generally "privacy," the other areas of consideration may then be derived from this point of view. The data privacy issue, although not derivative, is tightly coupled to the networking issue being bounded by access control and computer compartmentation.

Given the highly dynamic (and competitive) ADP technology and applications, the common teleprocessing ingredient appears to be the network or configuration with which ADP elements and their users are arranged over distance and through time. Categorization and characterization of candidate classes of networks and their management implications to DoD became the primary objectives of the effort undertaken.

Most off-the-shelf teleprocessing systems currently available are oriented toward a user-dedicated (usually owner) system of highly "integrated" network components consisting of (one or very few) computer sites connected to dedicated communications transmission lines and terminals. For each such dedicated system, management is system specific to the ADP/communications facility (i.e., teleprocessing system). Any sufficiently large corporate entity, and specifically DoD, will experience a demand for a multiplicity of diverse ADP services, each of which could, and in some cases may have to, be satisfied by dedicated teleprocessing systems. Consequently, higher level

management issues will develop with regard to shared versus dedicated facilities. In this regard, emphasis is given to aggregation of requirements, users, assets, and function as differentiated from specific systems design and operation. The current ADP technological and marketing environment is oriented toward supporting individual dedicated systems and as such would tend to proliferate networks and systems. To the extent that such proliferation is costly (or nonrevenue producing) teleprocessing management issues will have to focus on controlling or reducing proliferation through aggregation and sharing.

In the current ADP context, management contends with a multiplicity of dedicated teleprocessing systems. Another alternative is emerging through the development of common-user switched data networks\* in which computer sites and remote terminals are subscribers to a common-user data communications (sub)network. In this regard, the computers and terminals are differentiated from the communications. For this case the systems management function is considerably changed inasmuch as the data communications subnet is under separate management from the ADP and terminal sites. At the corporate level, common-user facilities become another option to be considered for implementing teleprocessing functions and sharing resources.

From the foregoing it should be evident that teleprocessing management issues require clarification and policies need to be developed. The purpose of this study was to identify, address, and categorize these issues as they apply to the DoD.

---

\* This approach has been given considerable support by DARPA with the development of the ARPANET. Three commercial firms (PCI, TELENET, and GRAPHNET) have been granted FCC approval to implement and tariff such common-user data communications while a time-sharing service company, TYMNET, is already utilizing a portion (~ 25%) of its communications capacity to provide common-user switched data communications. These companies use the basic transmission facilities of the Common Carriers and add their own data switching and multiplexing facilities for sharing capacity. Consequently, they are referred to as Value Added Networks (VANs).

## B. APPROACH

The objective of this study was to examine teleprocessing network design, configuration, and capabilities as they relate to DoD needs. This was done by area of application, by design alternatives and technology, and by development needs. This then leads to formulating policy issues and alternatives. A major difficulty has been the strong interaction between requirements, use, design, and ownership of teleprocessing systems. No accepted, "natural," or "right" decomposition and ordering of the problems have as yet emerged. The decomposition and structuring of teleprocessing system applications used here represent a framework the authors felt to be meaningful and to serve the purpose of being a point of departure for exhibiting the issues.

In this study teleprocessing applications are grouped into the following:

	<u>Category</u>	<u>Dominant Attributes</u>
Type I:	Command and Control	
	a. C <sup>3</sup> General Nuclear War	Survivability
	b. C <sup>3</sup> Crisis and Contingency	Peak Demand
Type II:	General Service Applications	Economic Use of ADP Functions

Excluded from consideration were the teleprocessing applications dealing with or integral to:

- Weapon Systems
- Tactical C<sup>3</sup>
- Intelligence

The weapon systems and tactical C<sup>3</sup> applications were beyond the scope of this effort. Due to the limitations of time and effort and considering the special access features associated with intelligence systems, this application area also was not addressed. A major policy issue for near-term consideration is the interaction between and

degree of facility sharing (terminals, communication, computers) among special and conventional teleprocessing networks.

The principal approach was used to survey and review technology, design, modeling, requirements, in general, and proposed DoD teleprocessing systems. From this effort, major issues and possible future directions were elicited and placed in relation to DoD alternatives. As discussed in Section V, detailed design analysis depends heavily on modeling and simulation requiring (1) significant data bases, (2) programmed models, and (3) iterative heuristic solution techniques. In all of the cases reviewed, the analysis and results tended to be quite specific requiring significant computational effort. Since a broad view of the problem area was the principal objective of this study, no attempt was made to develop a mathematical analysis. A review of the "state of knowledge" in analyzing teleprocessing systems is presented in Section V. To date, no broad theory of teleprocessing has developed.

### III. TELEPROCESSING APPLICATIONS

#### A. APPLICATION TYPES

In order to provide some framework within which teleprocessing networks could be judged, this study chose to categorize networks by utilization of attributes along classes of application in the DoD. Two major application areas identified and examined are listed below:

- Type Ia - Command and Control of the Nuclear Forces
  - Ib - Nonnuclear Crisis and Contingency Command and Control
- Type II - General ADP Services Applications

Although excluded from consideration, the tactical and intelligence applications clearly must interface and selectively share resources with networks supporting the above.

The purpose of categorizing teleprocessing needs by application area type is to focus the discussion on key system parameters. These parameters need not receive the same emphasis nor even need be compatible (e.g., survivability capacity, speed of service, geographic coverage, cost-effective throughput, etc.) between application types. The area types identified appear to have consistent parameters of design emphasis. These area types associate with a relationship between C<sup>3</sup> systems, the military forces, the military departments, and agencies of the DoD as shown in Fig. 1.

Type I applications are centered on NCA support with heavy WWMCCS involvement. Although each of the Type Ia and Ib functional areas may require support from systems designed with dedicated facilities, they should be strongly coordinated ("interoperable") between each other.

Type II needs, on the other hand, are very diversified with many points of focus. There can be expected to be many subcategories which will be discussed further in the report.

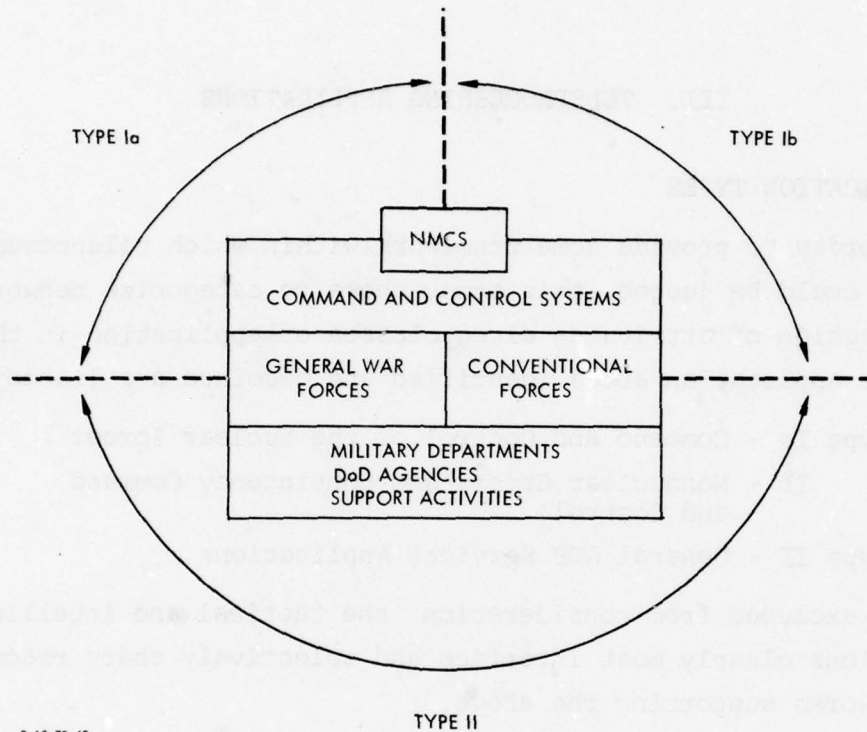

2-18-75-48

TYPE II

**FIGURE 1. Categories of Teleprocessing Applications in DoD**

Given a categorization of DoD teleprocessing needs, several questions as to implementation can be raised.

- Can some or all of Type Ia needs be met in a satisfactory manner by components of networks satisfying Type II needs?
- Alternatively, given a dedicated network to support Type Ia requirements, could it also support in part some Type Ib or even Type II needs?
- What are the balance and interfaces between a dedicated Type Ib network and preempts of Type II network capacities?
- What is the network relation between Type Ib and Type II?

The Type I and II categorization chosen was based on aggregating apparently consistent needs which dictate design requirements.

Developing such requirements in technical terms will then provide a means for judgment of network implementation.

Several broad network functional characterizations suggest themselves. The following lists some of these:

1. Degree of System Homogeneity/Heterogeneity between
  - Users
  - Hardware
  - Software
2. Connectivity and Data Exchange Demands
  - User density
  - Geographic coverage
  - Availability
3. Type of Service
  - Batch/remote job entry
  - Transactional/inquiry response
4. Capacity Needs
  - Average throughput
  - Speed of service
  - Load peaking
5. Special Features
  - Survivability
  - Priority/preempt
  - Multilevel security

In the remainder of this section, these functional factors will be discussed relative to the application area types.

It was felt that within the present understanding of the WWMCCS organization and assigned areas of responsibility within the Services, the categorization chosen is at least a useful point of departure. Moreover, there have been systems proposed which match (i.e., suggested) this categorization. For concreteness, these systems are used as examples in the discussion to follow. There is not a clear demarcation between systems' function and use. Very important architectural issues are yet to be determined. For real-time interactions

Type Ia need not be required to interact as closely with Type II applications as it would with Type Ib applications. On the other hand, Type Ib and some Type II systems could require close real-time interaction during crisis/contingency periods. The view could be taken that a Type Ib system serves as an interface between Type Ia and Type II systems. Status data collected in a Type II system could be forwarded periodically through a Type Ib system which interacts with Type Ia.

For the purposes of discussion, Types Ia and Ib are here separated in order to emphasize those functional attributes, survivability and peaking capacity demand, which can and will strongly influence and differentiate network design parameters. After discussing such systems separately, the issues of implementing interfaced but separate (sub)systems into an integrated system can be addressed.

The above discussion also applies to separating Type I systems from Type II systems. It is postulated that a considerable functional difference exists between Type Ia and Type II applications. Since Type Ia applications relate to the U.S. nuclear capability, and to the extent that these requirements dictate Type Ia system design, a separation of Type Ia from Type II applications is justified. It should be noted that in most peacetime modes (i.e., excluding test and training) a Type Ia system may be used for some Type II applications (but possibly at limited capacity and/or in a less cost-effective manner).

In summary, for the purposes of relating teleprocessing functional needs to design, three application areas are stipulated. The need for interaction between Types Ia and Ib as well as between Type Ib and certain Type II systems is clear. The need for real-time interaction between Type Ia and Type II is less obvious. The network functional designs will be outlined by type and compared.

#### B. TYPE I NEEDS

This section addresses Type I teleprocessing needs which are WWMCCS driven. Type I system needs are subdivided principally by the

nature of their teleprocessing design emphasis. Type Ia must emphasize survivable connectivity to specified units through the transattack period to pass a minimal volume of essential command data reports. Type Ib, on the other hand, must function with periods of large data capacity peaks without a priori knowledge of where and when such capacity will be needed nor the specific nature of the data. In addition, Type Ib systems need not be tasked to survive as high a nuclear threat level as that facing Type Ia systems.

1. Type Ia Systems--Command and Control Nuclear Forces

a. SATIN IV Synopsis. The SAC-proposed SATIN IV system fits within the Type Ia characterization as described in Ref. 6. The purpose of the SATIN IV system will be to provide an interactive data communications system by the late 1970s which would support command and control of SAC's general war forces and maintain connectivity with the NCA. It is to be an integral part of the WWMCCS under operational control of CINCSAC. The objectives of SATIN IV are to transmit critical command and control information including:

- (1) Command and orders, EAM (emergency action message) and essential operational data
- (2) Force management data
- (3) Situation data
- (4) Intelligence and force status data
- (5) Weather data
- (6) Other messages as necessary.

SATIN IV will have two modes. Mode 1 is primarily a ground-based transmission system; for enhanced transattack survivability, Mode 2 utilizes satellite (AFSATCOM) and air-to-air relay (PACCS) radio transmission at reduced transmission capacity. SATIN IV is also required to operate with the MEECN, EMATS, and AUTODIN communication systems. The SATIN IV system is planned to interface to the NCA at the NMCS command posts (NMCC, ANMCC, and NEACP).

The SATIN IV Mode 1 system is primarily a fast store and forward message switching network utilizing packet switching technology with

AUTOVON transmission facilities. This system is a distributed ground-based network interconnecting advanced data terminals at SAC units with computers (including a WVMCCS computer) at SAC Headquarters, Omaha, and the WVMCCS computer at the ANMCC at Ft. Ritchie. There are many sites with user terminal equipment (UTE) but only two host computer sites. The proposed network layout is shown in Fig. 2. This network utilizes transmission lines derived from the AUTOVON system with packet-type minicomputer switches (Regional Communications Processor--RCP) and concentrators (Base Communications Processor--BCP). The RCP switches are multiply connected to at least three other RCPs through AUTOVON for enhanced survivability through switch routing. The transmission speeds vary up to 9.6 kbps. The writer-to-reader system-response-time objective for highest precedent messages is no more than 10 sec. The transmission lines are derived by establishing AUTOVON calls at the Flash Precedence level with the intent to keep the called-up circuit in continuous full-duplex use. Should a line fail or be preempted (Flash Override), the RCP is to have an Autodial capability to call up another AUTOVON line.

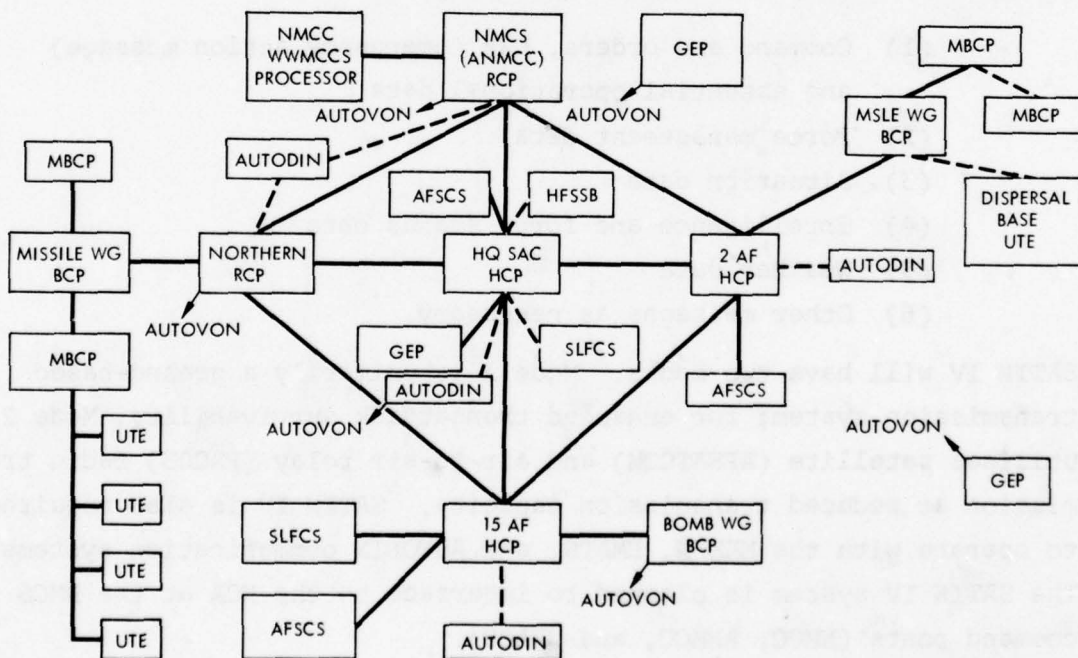

2-12-75-7

FIGURE 2. Proposed SATIN IV Network (Ref. 6)

b. Discussion of Type Ia Applications. As can be seen from the above synopsis, SATIN IV would be a backbone switched data transmission system within SAC and in support of the NCA. The management emphasis of the program is on data communications, yet examination of the system exhibits a strong dependence on teleprocessing design principles.

SATIN IV represents a major component of the Type Ia applications but does not cover all the needs. Mode 1 capability does not extend beyond SAC forces. To the extent that the other nuclear capable forces acquire AFSATCOM assets, Mode 2 operation can extend SATIN IV coverage beyond SAC forces. A single integrated Type Ia teleprocessing system has yet to be proposed. Interfaces between other CINCs and the NCA can evolve using the WWMCCS framework and MEECN, JCSAN, EMATS, AUTOVON, AUTODIN, SATCOM, etc., assets plus possibly extending the SATIN IV system or developing additional systems.

SATIN IV Mode 1 utilizes a subscriber-oriented packet-switching technology which also has potential for application to other switched data networks. However, SATIN IV would service a relatively homogeneous set of equipments and utilization factors (data formats, elements, exchange requirements). There are currently to be a very limited number of host computer locations in the system with relatively well-structured application requirements associated with the structured approach to command and control of the SAC nuclear forces.

SATIN IV will have to solve certain unique problems such as:

- Autodial capability on AUTOVON
- Air/ground radio links with AABNCP
- A variety of site-dependent interfacing problems such as SAC host computer complex and MINUTEMAN launch control facilities.

Mode 2 will have additional and possibly more severe interfacing problems induced by AFSATCOM reduced capacity and unique signalling format.

The SATIN IV system will be required to pass information classified through SI and ESI levels. The data security approach presently being taken is to secure the AUTOVON transmission lines to the appropriate level with conventional ComSec equipment. The switches and

terminals are to be physically located in secure areas. Several problems generic to multilevel security in all teleprocessing systems must be addressed. First, the switches and terminals must be guaranteed to some level of probability not to violate security through failure modes, misprogramming, or deliberate penetration attempts. For example, a sensitive data element should not be misrouted to an uncleared area. Second, the terminal and computer will have to be secured in validating the terminal's "user" (usually human but possibly another machine) right to interact with the information at a given level and protection against misuse or failure. When the terminal is in a secure area, the principal burden is placed upon the host computer. The computer must check user ID (identification) and validate his credentials. Then the computer needs to generate internal barriers to deny the user access to data and programs beyond his "access rights." This latter function is essential and short of physically separating computers; no fully satisfactory approach to solving this problem is known for time-sharing multiuser computing systems.

The problem of interfacing Type Ia systems to other DoD teleprocessing networks remains. In Ref. 7 consideration was given to some of the technical problems in data structure and security for interconnecting SATIN IV to AUTODIN II (Ref. 1). There still remain unaddressed problems relating to control, precedence, and usage factors. These problems are further described in Section VII-E.

c. Summary Type Ia Systems. It can be expected that the following features are generic to Type Ia teleprocessing systems:

- Structured nature of ADP work load as determined by nuclear war planning
- Relative homogeneity of users and their individual equipment
- High emphasis on survivable connectivity through transattack
- Site-unique features of nuclear forces and command centers.

Design features which decrease available and survivable system capacity may not be tolerable. For example, intermittent system

blockage or delays caused by an inadequately controlled set of user access during a period of peak demand could be very deleterious. Increased cost-per-unit throughput added by survivability features may be tolerable for Type Ia users but not others. Performance measures of Type Ia systems should be heavily oriented toward maximizing probability of timely delivery of essential messages between command and forces in the face of maximum threat levels. This contrasts to economic-oriented measures for Type II systems which would focus on cost-effective performance such as minimum-cost-per-system transaction.\*

## 2. Type Ib Systems--Crisis and Contingency Command and Control

a. WWMCCS Teleprocessing Objectives. Type Ib application areas relate to WWMCCS support of the NCA for command and control capabilities of U.S. forces through Crisis and Contingency operations. One means for enhancing this capability is the proposal to interconnect and thereby interoperate with selected WWMCCS ADP sites. At present, the Joint Technical Support Activity (JTSA)\*\* is conducting an experiment, the Prototype WWMCCS Intercomputer Network (PWIN), to interoperate three WWMCCS computers, one each at the following sites: JTSA/Reston, Va., NMCSSC/Pentagon, and CINCLANT/Norfolk, Va. Several proposals have been advanced to enlarge the number of WWMCCS ADP sites to be interconnected. One is to expand the experimental PWIN (Expanded PWIN); another is to establish a separate operational WWMCCS Internet (WIN) (Ref. 8), or utilize at some future date the DCA-proposed AUTODIN II (IDN) common-user switched data network.

---

\* This is one of many of the Type II economic performance measures. Another might be maximum operating dollars saved per dollar teleprocessing invested. The principal point is that Type Ia has radically different basis for design and economic justification.

\*\* JTSA, under the cognizance of the Director, DCA, serves as the WWMCCS ADP System Manager responsible to the JCS.

The broad ADP objectives of a WWMCCS Internet in ascending order of difficulty will be to:

1. Provide overall continuity of ADP operations through individual computer failures.
2. Utilize geographically distributed data bases in order to (a) maintain more current file data, (b) reduce the volume, time, and cost of daily file transfers, and (c) minimize duplication of data bases and their support costs.
3. Acquire an advanced, distributed, interactive, and transactional system capability to support quick reaction contingency planning for command and control of the U.S. forces.

b. WWMCCS Data Flow. In May 1972, a study (Ref. 9) was published projecting WWMCCS intercomputer traffic flow for the late 1970s. This study was conducted for JTSA by Mitre Corporation. The data were compiled through extensive interviewing of WWMCCS ADP site personnel. This study is useful for the manner in which the data transactions were organized and in estimating projected traffic flow.\* This structure is repeated here in summary form. The WWMCCS element relationships used by the Mitre study are shown in Fig. 3 showing NMCS, CINC and CINC components in the WWMCCS. The data to be exchanged were put into six operational groupings. Associated with each are the indicated reporting systems (for summaries of these reporting systems, see Ref. 9).

---

\* These values for initial planning estimates were derived prior to experience with PWIN, subsequent WWMCCS ADP developments, and OSD guidance.

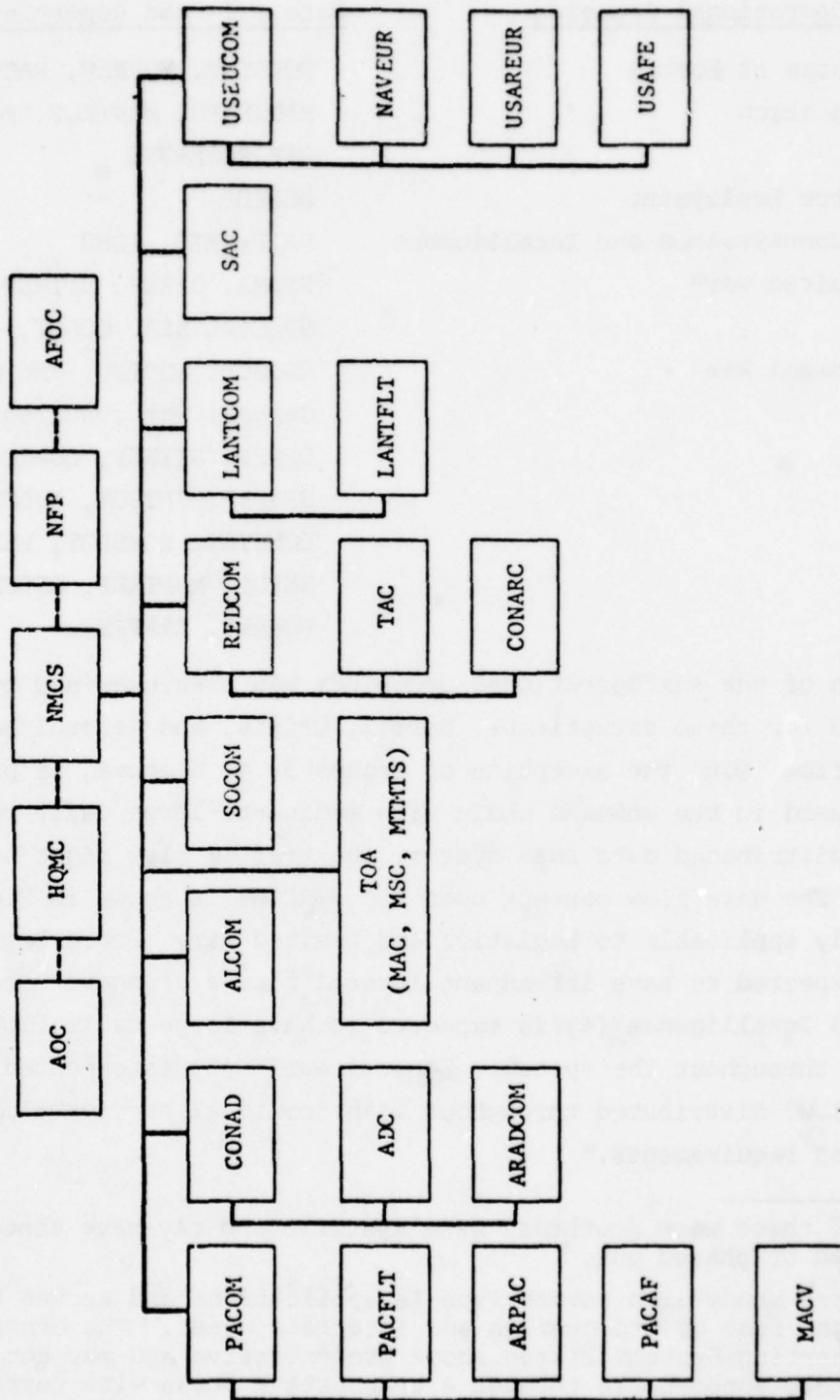

FIGURE 3. WWMCCS Element Relationships (Ref. 9)

Operational Grouping

Data File and Reporting Systems

1. Status of Forces	FORSTAT, MOVREP, PACREP
2. Logistics	PACSHIPS, MUNIREP, POLREP, WAR RESERVES
3. Force Deployment	DEPREP
4. Reconnaissance and Intelligence	PATF, RIS, IDHS
5. Limited War*	FRDMA, OPREP, SITREP, SPECIAL SEA, COACT, ALOREP
6. General War	CAOSOP, NUCINV, and under General War conditions, OPREP, SITREP, COACT, DISUM, SPIREP, INTSUM, NUDET, NUSUM, COMSTAT, COMSPOT, PERSTAT, REPOL, MUNIREP, REDSEAL, POLREP, CRAFREP.

Each of the six operational groupings was then examined by Mitre in Ref. 9 for three situations: Normal, Crisis, and General War. The traffic flow, with the exception of groups 3, 4, 6 above, is principally upward in the command chain with medium-to-large daily volumes (with a distributed data base system, the traffic flow might be reduced). The data flow concept used for FORSTAT is shown in Fig. 4 but is equally applicable to Logistics and Limited War. Force Deployment (3) is expected to have infrequent lateral flow exchanges. Reconnaissance and Intelligence (4) is expected to have large daily flow distributed throughout the system. General War\*\* (6) is expected to have "large flow" distributed throughout with "critical survivability and timeliness requirements."

---

\* Some of these were Southeast Asia specific and may have since been modified or phased out.

\*\* The Mitre study also covers Type Ia applications and serves to highlight some of the overlap and interface needs. The General War Reporting Systems listed above are extensive and may not be completely supportable through a transattack phase with current and projected Type Ia systems.

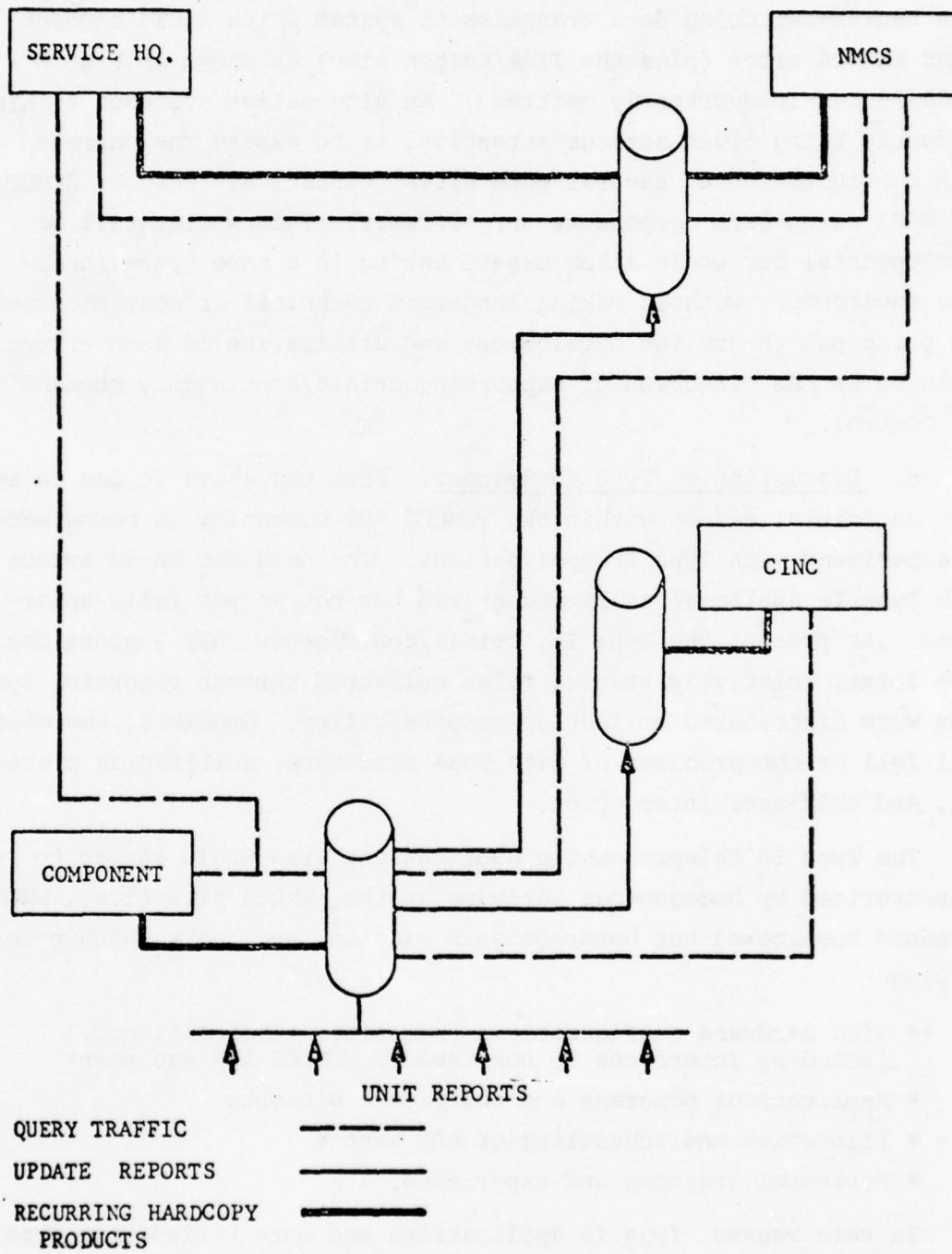

FIGURE 4. Example FORSTAT Strategy (Ref. 9)

c. PWIN and WIN Synopsis. The WIN system proposed in Ref. 8 is a packet-switching data transmission system which would connect eight WWMCCS sites (plus the JTSA/Reston site) as shown in Fig. 5 (JTSA/Reston inadvertently omitted). An alternative approach to WIN, currently being given serious attention, is to expand the current PWIN configuration to several more sites (tentatively REDCOM, ANMCC, and MAC) using PWIN components and software. This would still be developmental but would allow experimenting in a more operational-type environment without making long-term technical or cost commitments. The principal thrust for development and utilization of such effort would be in the direction of supporting crisis/contingency command and control.

d. Discussion of Type Ib Systems. From the above it can be seen that an initial effort within the WWMCCS ADP community is being made to experiment with Type Ib applications. The need for an interface with Type Ia applications is recognized but not as yet fully understood. At present the Type Ib, crisis/contingency, ADP support deals with large, relatively static, files collected through reporting systems with distributed collection responsibility. Emphasis, therefore, will fall on the problems of data base structure, utilization protocol, and multiuser interaction.

The Type Ib teleprocessing applications area would appear to be characterized by homogeneous hardware at the WWMCCS site (i.e., WWMCCS standard computers) but heterogeneous missions and tasks which generate varying

- Site hardware configurations (memories, terminals, etc.) including interfaces to nonstandard WWMCCS ADP equipment
- Applications programs and their data elements
- Allocation and scheduling of ADP assets
- Personnel training and experience.

In this regard, Type Ib applications are more varied than Type Ia but still retain some hardware homogeneity (as compared to Type II) through the standard WWMCCS ADP computers. In further contrast to

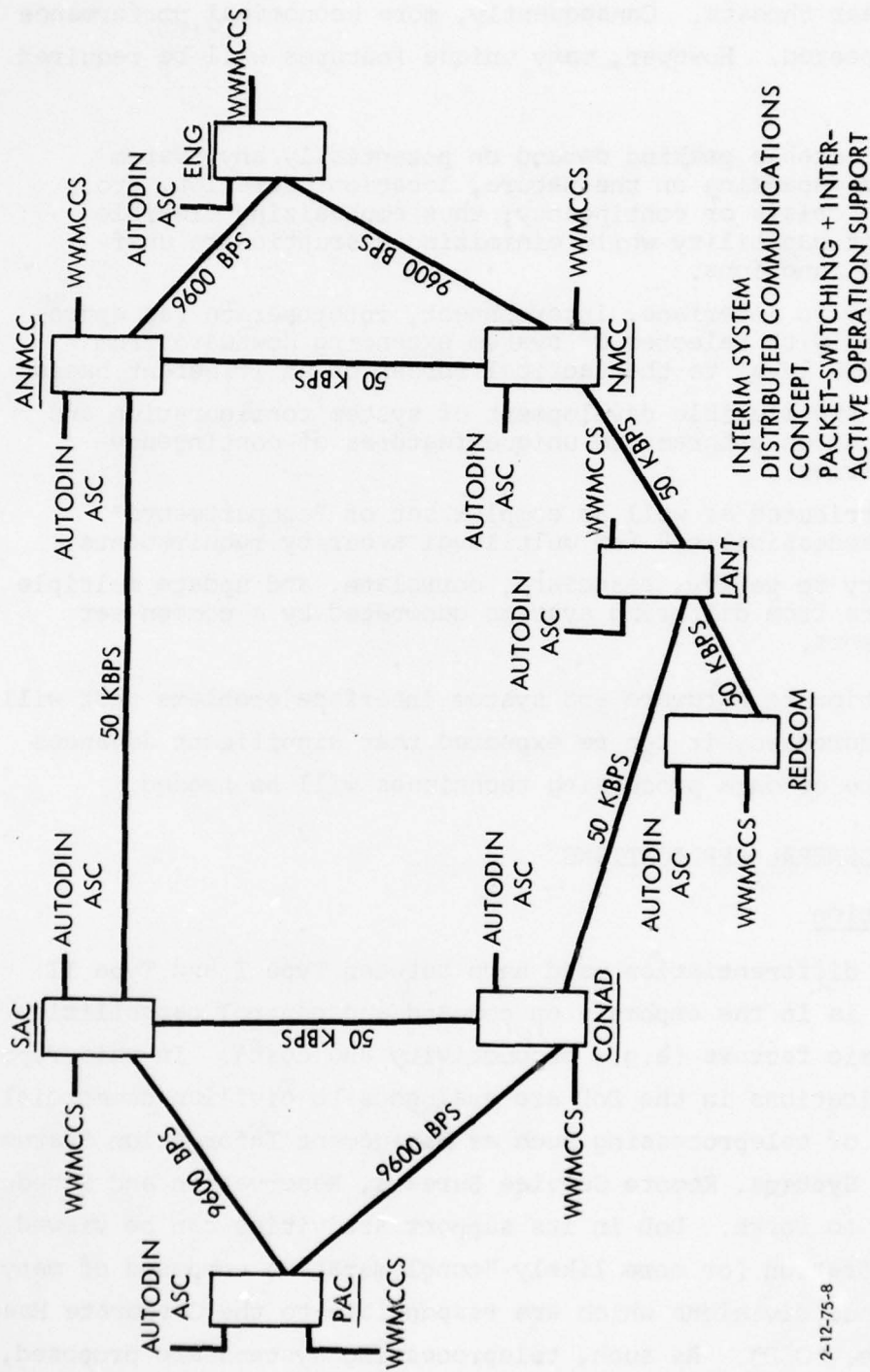

FIGURE 5. WWMCCS Intercomputer Network Proposed in Ref. 8

2-12-75-8

Type Ia, Type Ib need not require as high a level of survivability against nuclear threats. Consequently, more economical performance should be expected. However, many unique features will be required such as:

- Unpredictable peaking demand on potentially any system assets depending on the nature, location, duration, etc., of the crisis or contingency; thus emphasizing flexible preempt capability while minimizing disruption to unaffected functions.
- Ability to interface, interconnect, interoperate (as appropriate) with selected C<sup>3</sup> system extending downward from the CINC level to the tactical forces on an itinerant basis.
- Rapid and flexible development of system configuration and application programs to unique features of contingency activities.
- A distributed as well as complex set of "compartments" and "accessibility" for multilevel security requirements.
- Ability to verify, associate, correlate, and update multiple reports from differing systems generated by a common set of events.

In addition to hardware and system interface problems that will have to be addressed, it can be expected that significant advances in the science of data processing techniques will be needed.

## C. TYPE II GENERAL APPLICATIONS

### 1. Introduction

A major differentiation used here between Type I and Type II applications is in the emphasis on command and control capabilities versus economic factors (e.g., productivity and cost). In this report, Type II applications in the DoD are analogous to civilian commercial applications of teleprocessing such as Management Information Systems, Time-Sharing Systems, Remote Service Bureaus, Reservation and Scheduling Systems, and so forth. DoD in its support activities can be viewed as a large corporation (or more likely "conglomerate") composed of many semi-autonomous divisions which are responsible to the Corporate Headquarters (i.e., OSD). As such, teleprocessing systems are proposed, acquired, and used by the various Corporate Division elements in order

to support their daily operations, increase productivity, and reduce costs (usually personnel). The problem of managing Type II systems in DoD is similar to a commercial corporation except that the problems are amplified by the extensive geographical distribution of activities and very large size of the DoD.\* One of the principal concerns of this report relates to identifying problems and structuring policy and strategy alternatives for managing "Corporate" use of teleprocessing.

Within DoD, Type II teleprocessing applications can be aggregated in many different subtypes. This variability in possible aggregations is in of itself a major problem. No a priori "natural," good, or attractive aggregation of teleprocessing applications has yet to suggest itself. In this section several alternative classes of teleprocessing applications will be discussed in Sections 3 through 5.

## 2. Discussion of Type II Applications

a. Systems and Organizations. There is a very large variability in Type II applications. However, one common factor is the emphasis placed on economical delivery of ADP goods and service with less stringent requirements on survivability or timeliness as there is with Type I systems. Type II applications may vary from homogeneous systems to very heterogeneous ones. The level of difficulty in the design and operational utilization problems of a Type II system can be expected to be higher with greater heterogeneity of hardware, software, and community of users.

Requirements Formulation (Section IV) and user/system organization will be a major issue for Type II Teleprocessing Applications. A variety of Type II categorizations (or hierarchies of categorization) are possible. Several methods of aggregation suggest themselves as follows:

---

\*In this regard, although DoD is a very large "Corporation" indeed, it still represents a small fraction of the aggregated total business consumption of ADP goods and services.

- By organization of an associated user community such as components of military departments or agencies, command activities, mission activities.
- By geographical regions.
- By similarity of applications systems such as logistics and supply, operations scheduling, status reporting, personnel, finance.
- By the technical characteristics of the ADP and communications load and service such as batch processing, centralized bureau ADP support, remote job entry, transactional or inquiry/response, circuit or packet switching, common interface standards, etc.
- By security requirements.

The above modes derive from consideration of (1) conventional organizational structure, (2) geographic proximity, (3) standardization of function, (4) type of ADP work load, and (5) constraints in mixing sensitive data. It has not been possible to discover a best mode for aggregating. Each has advantages and disadvantages and, with the possible exception of aggregation by technical characteristics and security, Type II systems have been proposed which reflect each of the first three modes. For example, consider the following proposed systems:

- By organization--MAC Information Management System
- By geographical region--Navy Data Processing Service Center and Army Northeast Computer Center
- By standard\* applications--Joint Uniform Military Personnel Systems (JUMPS)

The SADPR-85 Computer Network concept discussed in the following represents a mix of the organization and geographic aggregation modes but within a well-defined and unique military organizational structure. On the other hand, JUMPS is a DoD-wide standard system to be implemented across the Services. A major issue is to determine the mix

---

\*The strongest version of this approach would be a DoD-Wide Standard System. Less stringent versions would be a Military Department-Wide Standard System.

of aggregation modes, the resulting overlap and required information exchange and interface between different systems. Each approach has advantages and drawbacks some of which are identified in Table 1. Table 1 exhibits modes by which teleprocessing systems can be organized.

TABLE 1. MODES OF SYSTEM AGGREGATION OF TELEPROCESSING SYSTEMS

Mode of System Aggregation	Advantages	Disadvantages
By Organization	<ul style="list-style-type: none"> <li>• Close association of users' missions and functions.</li> <li>• Conventional identification of management responsibility</li> <li>• Matches current development practice</li> </ul>	<ul style="list-style-type: none"> <li>• System functional duplication</li> <li>• System inefficiencies through lack of specialization</li> <li>• Generate more complex data, data exchanges and reporting</li> </ul>
By Geographical Region	<ul style="list-style-type: none"> <li>• Minimizes communication costs</li> <li>• Possible economy of scale</li> </ul>	<ul style="list-style-type: none"> <li>• Emphasizes "service" bureau capability at expense of specialized service</li> <li>• May not provide adequate on-line service for geographically extensive operations</li> <li>• May have adverse impact on data security protection</li> </ul>
By Standard Application	<ul style="list-style-type: none"> <li>• Standard reports</li> <li>• Economy of scale in hardware and software</li> <li>• Common training and support</li> </ul>	<ul style="list-style-type: none"> <li>• May not provide adequate support for mission-oriented operations.</li> </ul>
By Technical Characteristics	<ul style="list-style-type: none"> <li>• Allows separation and independent optimization of grossly differing ADP processing tasks</li> </ul>	<ul style="list-style-type: none"> <li>• Can fractionate ADP support to end users</li> </ul>
Special Considerations, e.g., security/privacy	<ul style="list-style-type: none"> <li>• Simplifies technical realization of special objectives</li> </ul>	<ul style="list-style-type: none"> <li>• May unnecessarily inhibit system access</li> <li>• Can escalate costs through asset duplication</li> </ul>

b. ADP and Communications. A second major issue area paralleling the aggregation and organization of users is the relationship between computer facilities and communications. These underlying issues are focused by the need to determine a balance between dedicated and shared teleprocessing systems on the one hand, and the mix of dedicated data transmission circuits and common-user data networks on the other hand.

Economies of scale must be considered but in a wider context than communication costs alone. Issues of centralized versus decentralized ADP support facilities or, more generally, the DoD ADP economic structure together with security, O&M, special performance requirements, and interoperability must be considered. Elaboration on these issues for Type II systems forms the principal purpose of the following sections of this study.

No ADP systems are static. There is perhaps a higher rate of change in ADP, through hardware and software modification, evolutions, and major new introductions, than in any other technically oriented field. Thus, of particular significance will be the evolution through time of Type II applications and systems. Policy and management guidelines must be developed to aid in the initiation growth, consolidation, replacement, and sharing between and amongst teleprocessing systems for Type II applications. There is as yet no purely technical basis from which such guidelines can be meaningfully derived. As ADP capability becomes more potent at less cost, the possibilities widen rather than narrow. In all likelihood successful guidelines will have to be derived by a coordinated management decision from major OSD policy objectives, organizational and institutional responsibilities, and critical functional deficiencies.

### 3. Merger of Existing Systems: A Case Study

Prior to further discussion it is illustrative to consider a specific example of the corporate level Type II teleprocessing management problem. A major U.S. corporation with worldwide activities found that within CONUS two of its major operating divisions, Sales

and Field Engineering Service, had independently developed and maintained two separate and dedicated teleprocessing systems, each possessing its own terminals, communication lines, and host computers, and each organized in a conventional network of a central computer supporting remote terminals. Investigation by Corporate Headquarters revealed that these systems were highly congruent in terminal distribution, type, and usage, together with similar host computers. In fact, for the most part, Sales and Field Engineering shared the same local and regional office facilities with duplicate terminals and communication lines. The host computer sites are located at Division Headquarters which, in turn, are separated by only a few miles. Thus, terminals and communications were being duplicated.

All hardware and operating software for both systems were purchased from a single supplier. Moreover, the type of terminal-to-host data transactions were quite similar. Thus, a merging of both systems offered the potential for considerable reduction of cost in terminals, communications lines, and potentially host computers.

The corporate management proceeded with a partial merger while maintaining separately the functional identity of each application system. The old terminals (which were due for upgrading) were replaced with a reduced number of new cathode-ray tube (CRT) terminals which are shared by both Sales and Engineering personnel at the common field office. The redundant communication access lines and leased long-haul data trunk capacity were phased out. The separate host computers, however, are retained. New terminal concentrators had to be acquired which would direct a data call to the desired host computer (or its backup). A moderate software engineering cost was required to implement the shared system. The option remains to merge the host computers at some future date.

It is important to emphasize several points in the above example: (1) the locations of use were essentially identical; (2) the hardware and its resident operating software are from one supplier and were, if not identical, certainly compatible for interoperation; (3) the

original separate systems were centralized with a star configuration and little switching; the shared systems are still centralized with essentially an overlapping star configuration and minimal switching; (4) software input was required to implement the shared system; (5) identity of functional service was maintained separately and host computers are not as yet merged\*; and (6) the system merger is still under way and operational experience is still being developed. These points serve as preliminary introduction to problem areas which will be more fully addressed in the remainder of this report.

4. Replacement with a New System: The Air Force SADPR-85 Base Level Computer Network Concept

a. Objectives. A highly illustrative example of a comprehensive teleprocessing system which would utilize a backbone switched network is provided by the SADPR-85 Computer Network concept (Ref. 2) developed at ESD with Mitre support. Concerned with the potential future obsolescence of the present, essentially stand alone, Base Level ADP assets together with an expected expansion of Base Communications traffic load, the Department of the Air Force tasked ESD to conduct a study to satisfy a 1985 projected ADP/communications work load at base level and to examine several alternative teleprocessing configurations and their costs to meet the projected demand.

The SADPR-85 Computer Network concept consolidates all the present Base Level ADP activities into some 11 regional ADP centers while adding major new transactional capabilities by using interactive terminal-to-computer and small-computer to large-computer communications. The present Base Level ADP systems are provided at approximately 130 Air Force bases, worldwide. At each typical site

---

\*In this regard, although the host computers were from the same manufacturer with very similar operating systems, their peripheral configurations, applications programs, task scheduling, and support personnel were sufficiently different to raise management concern as to cost and time to cut over to a merged system. Problems of management accountability for satisfactory performance of a merged computer facility were also of concern.

there is a Burroughs 3500 machine and a UNIVAC 1050 machine. These facilities support primarily batch-operated applications programs. There are, however, on the average of 15 time-sharing teletype terminals (mostly on site) per computer which operate in an elementary time-sharing mode on relatively static data bases generated by the primary applications.

A variety of applications programs are run at these facilities. The periodically generated data cards (or tapes) together with their (batch) processing form "applications systems" which are supported by these computer facilities. The processed data (i.e., report) are then forwarded to system participants for any further processing, review, management action, etc. In order to provide by example the scope of these activities, some of the "applications systems" are listed below:

#### B-3500 Oriented Systems

- Base Engineer Automated Management (BEAMS)
- Base Level Mil Pers (BLMPS)
- Civilian Pay (ADS NY)
- Civilian Personnel Management Information (CPMIS)
- Computer Directed Training (CDTS)
- Customer Integrated Automated Procurement (CIAPS)
- Maintenance Management Information & Control (MMICS)
- Medical Material Management (MMMS)
- Vehicle Integrated Management (VIMS)
- Non-Temporary Storage of Household Goods (ADS NO)

#### U-1050 Oriented Systems

- Air Force Standard Base Supply
- Mil Aircraft Storage and Disposition Center Management (MASDC)

In order to achieve the desired consolidation and introduce major new teleprocessing capabilities the study proposed the following computer network concept:

The Command-centered Computer Network concept is based upon the idea of providing the bulk of Air Force base-level ADP support at a few locations. There will be nine processing centers in the CONUS, two overseas and one each for training and for systems development. The processing centers will each include a multiprocessor with a large communications processor to handle the communications interfaces. The nine CONUS centers will be interconnected by wideband communication links and each Air Force installation will have two independent access lines to this network of processors.

Each active base will be equipped with a large minicomputer system for local processing in the event that a communications failure separates the base from its command processor. Small minicomputers will be installed to assist in data entry and retrieval. These systems may be dedicated to one or two functional areas or shared, depending on the conclusions of the functional analyses. Data terminals will be allocated roughly in proportion to base population, with an average base receiving about 200 terminals.

The potential advantages of the Computer Network concept identified by the SADPR-85 study are as follows:

(a) Powerful, multiprocessing systems with redundant components can provide higher availability and reliability than smaller, free-standing processors.

(b) Significant reductions in operations personnel can be realized.

(c) A broader range of specialized functions provide great flexibility in application.

(d) A simplified command management is facilitated by the use of a few, interconnected, processors that enable a small number of systems which can support all functions for all units belonging to a command.

(e) Fewer facilities are required, reducing system costs.

(f) Maintenance and control of software is easier since there are fewer sites.

In addition to direct cost savings of the expected reduced manning requirements\* of item (b) above, qualitative benefits are

\* A model for estimating Manual Information Handling (MIH) man-hours per day consumed by the Air Force indicates a reduction by approximately 50% over current levels through use of improved ADP systems.

expected in light of the limited expected availability of trained manpower in the 1980-90 time frame.

b. Conceptual Configuration. The Host Regional and Satellite Base configuration concept is shown in Figs. 6a and 6b. The hardware characteristics envisioned are shown in Table 2. The projected CONUS network interconnection is shown in Fig. 7. There is also connected to CONUS a Pacific subnetwork with processing center at Hickam AFB and a European subnetwork with processing center at Ramstein, Germany. The interbase communications network utilizes 50-kbps backbone circuits with lower speed access lines. The transmission and switching concept is based on ARPANET packet technology. The communication subsystem concept has been developed to allow for potential utilization of AUTODIN II (next section).

TABLE 2. COMPUTER NETWORK CONFIGURATION (Ref. 2)

Network Processing Centers (11)

- 1 Multiprocessor (8 MB main memory)  
6-10 Billion byte disk memory
- 12 Magnetic tape drives
- 1 Computer Output Microfilm unit
- 1 High-performance batch terminal
- 1 Large communications processor (128 Kbytes main memory)  
100 Mbytes disk memory

Major Bases (103)

- 1 Large minicomputer system (64 Kbytes main memory)  
200 Mbytes disk memory
- 2 Small minicomputer systems (32 Kbytes main memory)  
5 Mbytes disk memory each
- 1 Coaxial cable system including network controller
- 1 ATP communications processor
- 1 Interface Message Processor
- 1 High-performance batch terminal
- 1 Key-disk data entry system
- 75-335 Data terminals

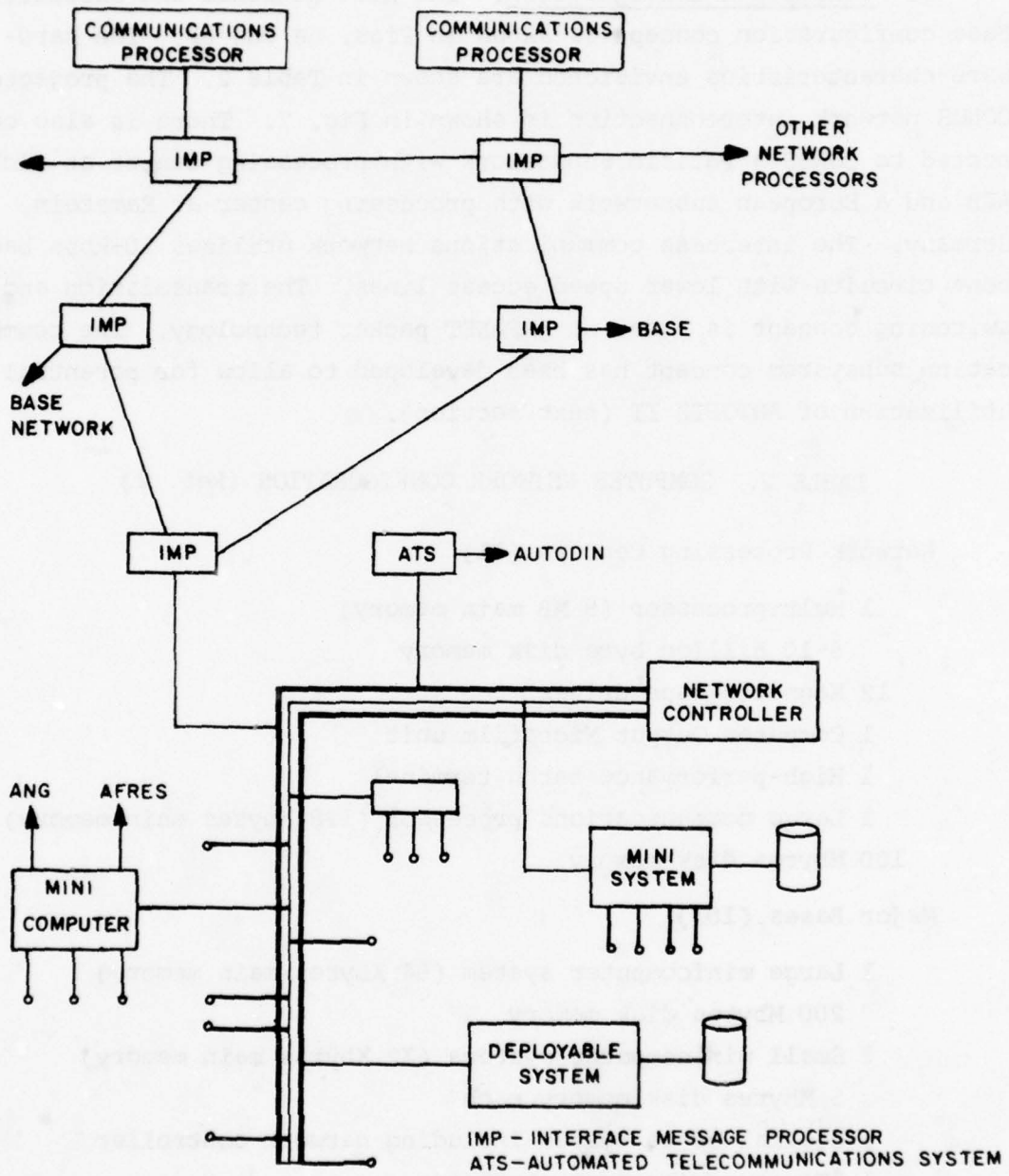

FIGURE 6a. Satellite Base Configuration (Ref. 2)

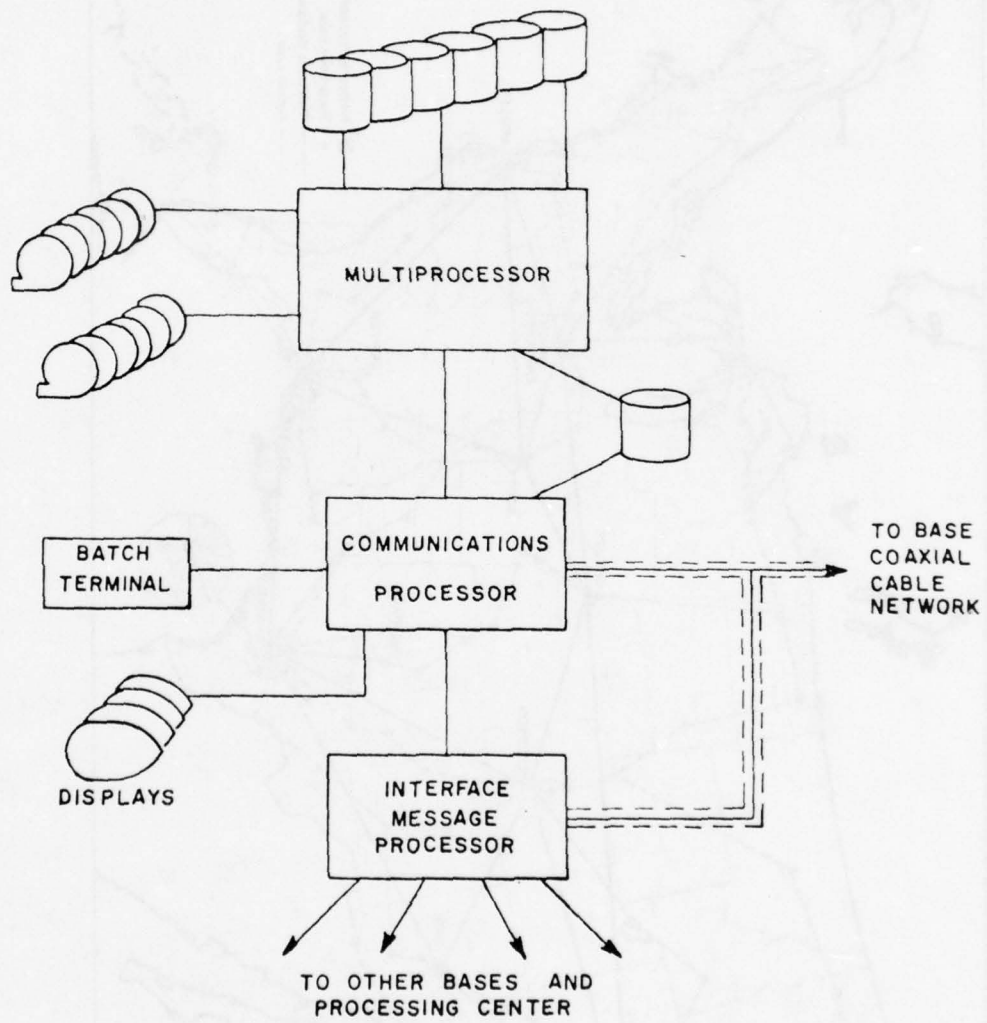

FIGURE 6b. Host Computer Network Processing Center Configuration (Ref. 2)

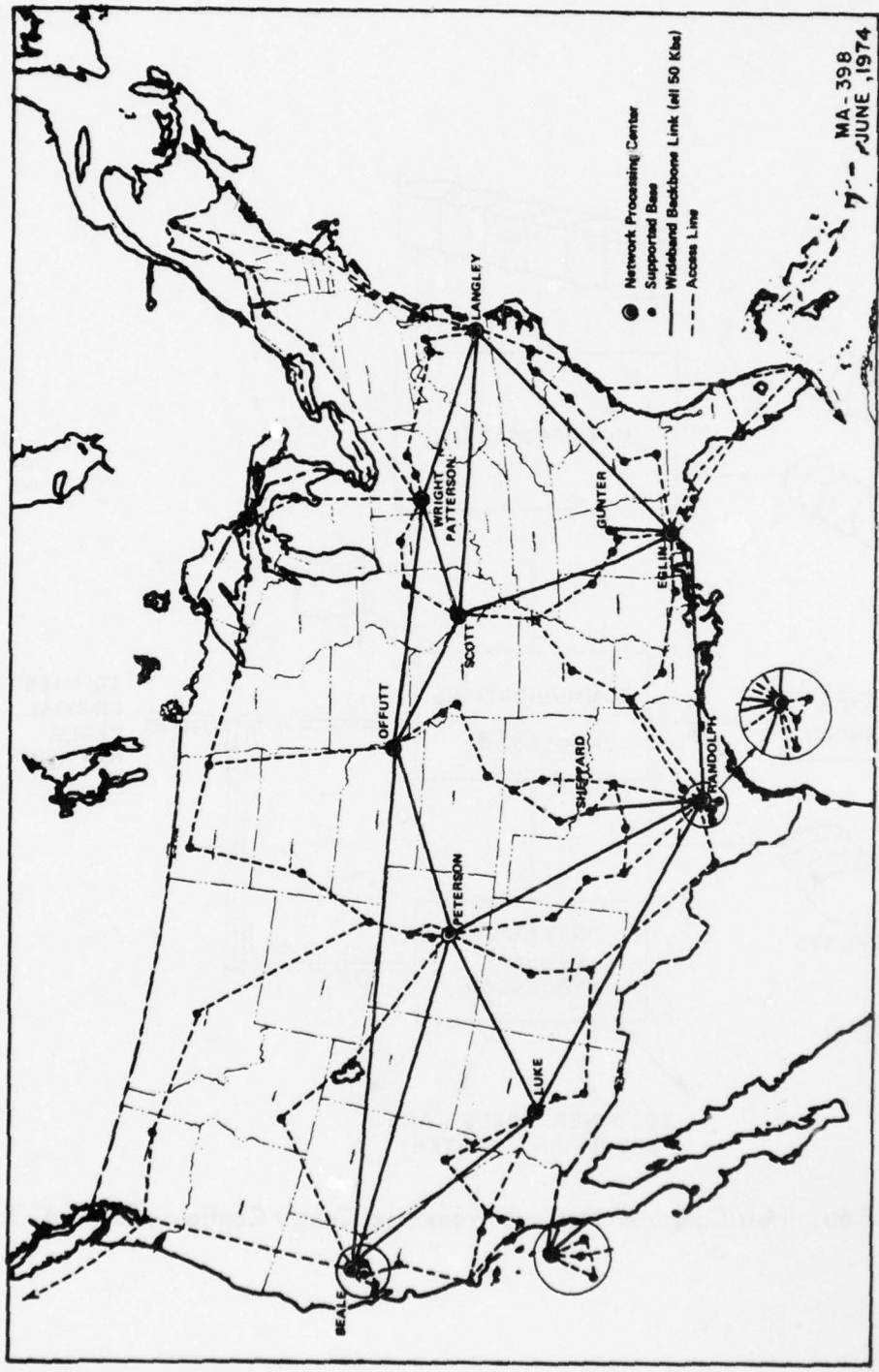

FIGURE 7. Proposed SADPR-85 Network Topology (Ref. 2)

The on-base communications envisions installation of a looped very-high-speed (1 Mbps) coaxial cable utilizing time-division multiplexing techniques wherein each on-base subscriber accesses the cable through a Subscriber's Digital Interface Unit (SDIU). The very high transmission speed in comparison to any user's needs alleviates interface and timing problems. The Spider system at BTL (Ref. 10) has been operating successfully utilizing this approach.

c. System Features. The overall desired "writer-to-reader" response time objective for the highly interactive teleprocessing modes of operation is 2 sec. Considerably more delay is tolerable for bulk-type data transfer (e.g., files). The overall security level objective would appear to be no more than Secret which, if not upgraded, would considerably mitigate the ComSec requirements (and costs). The impact of less stringent security on the host computer facilities is not clear as privacy-type issues may be important (e.g., personnel and medical data are involved). At present, only the obvious can be said in that the criteria and standards for privacy can be quite different (and presumably less stringent) than those for multilevel security.

Some of the software features to be provided at the major Regional sites, as stipulated in Ref. 2, are as follows:

(a) A Generalized Data Base Management System (CODASYL Data Base Task Group standard or equivalent).

(b) A high degree of integrity for all files (protection from accidental damage), and a capability for continued effective operation in the event of some processor or memory failures.

(c) A variety of mathematical packages including linear programming and integer programming (required for scheduling systems).

(d) Several special packages such as text editing to support report generation and computer aided instruction to support training systems.

d. Economic Comparison. In order to gain a perspective on the communication subnetwork in relation to the computer (ADP) and utilization (O&M) costs, it is instructive to examine the expected cost

components developed in the SADPR-85 study (Ref. 2) of four major system alternatives. These alternatives are as follows:

- "1 - Baseline - Respond to Individual Program Developments as needed--continues present approach. Replace components and augment installations site-by-site as needed. Acquire more interactive terminals.
- 2 - Augmented Baseline - Enhance baseline approach with increased use of remote terminals, com front ends, utilize present circuit switched com facilities.
- 3 - Base General - Further develop base centered system using remote interactive terminals and add-on digital data communication subsystem.
- 4 - Computer Network - Replace current system with new totally integrated teleprocessing system."

The cost data presented herein are abstracted directly from the SADPR-85 study. No attempt was made to review or verify the accuracy of these cost data nor is it the intent herein either to endorse or critique the SADPR-85 study results.

Most of the SADPR-85 projected ADP hardware and communication costs are made on a rental or leased basis and the cost data do not include discount values or inflation factors. To gain insight on the relations between communication, computer, and utilization costs, the absolute values of the cost elements are of less importance than the cost relation between these elements. Consequently, cost elements are compared here on a percentage basis. Tables 3 and 4 show the expected cost components as a percentage of the projected total 15-year cost (1974-90) for each alternative. In Table 3, the cost element is shown as a percentage of the total cost of its associated alternative\* which is shown in the lower portion of the table. Table 4 provides a further breakdown of the communications system life-cycle cost components of the Computer Network (alternative 4) costs. For

---

\* Comparisons between any two alternatives should be further adjusted by the ratio of alternative costs.

TABLE 3. SADPR-85 (Ref. 2) COMPONENT LIFE-CYCLE COST ESTIMATES  
(1975-90) AS PERCENTAGE OF TOTAL COST  
(Exclusive of Base Operation Support)

Cost Component	Alternative			
	#1 Baseline	#2 Augmented Baseline	#3 Base General (phase down* component)	#4 Computer Network (phase down* component)
Sys Engr & Mgmt	0.05%	0.2%	2.7%	3.2%
ADP Equipment	30	39	29	32 (20)
Communications	0.8	0.7	4.6 (0.3)	7.3 (0.4)
Software**	0.4	0.4	4 (0.1)	4.4 (0.1)
O&M	39	59	59 (28.4)	53 (30)
Facility Support	0.1	0.1	0.8 (0.1)	0.5 (0.2)
TOTAL, \$M (phase down* equipment)	1909	2213	1944 (839)	1677 (839)
Base Operation Support, \$M	184	184	175	135
GRAND TOTAL, \$M	2093	2397	2119	1812
Approximate Manning Level	5000	5000	4000	2000

\* Cost of operating present system while implementing this alternative. This value is shown in parenthesis.

\*\* Includes cost estimate of recoding current COBOL applications programs.

TABLE 4. SADPR-85 (Ref. 2) ESTIMATED LIFE-CYCLE (1975-90)  
COMMUNICATION COMPONENT COSTS AS A PERCENTAGE OF TOTAL  
COMMUNICATION COST (\$116M) OF COMPUTER NETWORK CONCEPT  
(Alternative 4 Above)

Cost Category	On-Base Percent	Inter-Base Percent	Net Percent
Processor	28 %	7.5%	35.5%
Crypto	5.5	.8	6.3
Circuits	12.2	22.3	34.5
Other Equipment	10		10
Associated Support	1.6		1.6
Maintenance	11.7	0.4	12.1
TOTAL	69	31	100 = \$116M

the Base General and Computer Network alternatives, the current ADP facilities will have to be maintained while these systems are brought on-line. Thus, there is incurred a phase-down cost of the current facilities which must be added to the implementation costs. This is reflected in Table 3. It can be seen that the phase-down costs are almost as much as the acquisition costs. The expected annual costs are shown in Fig. 8.

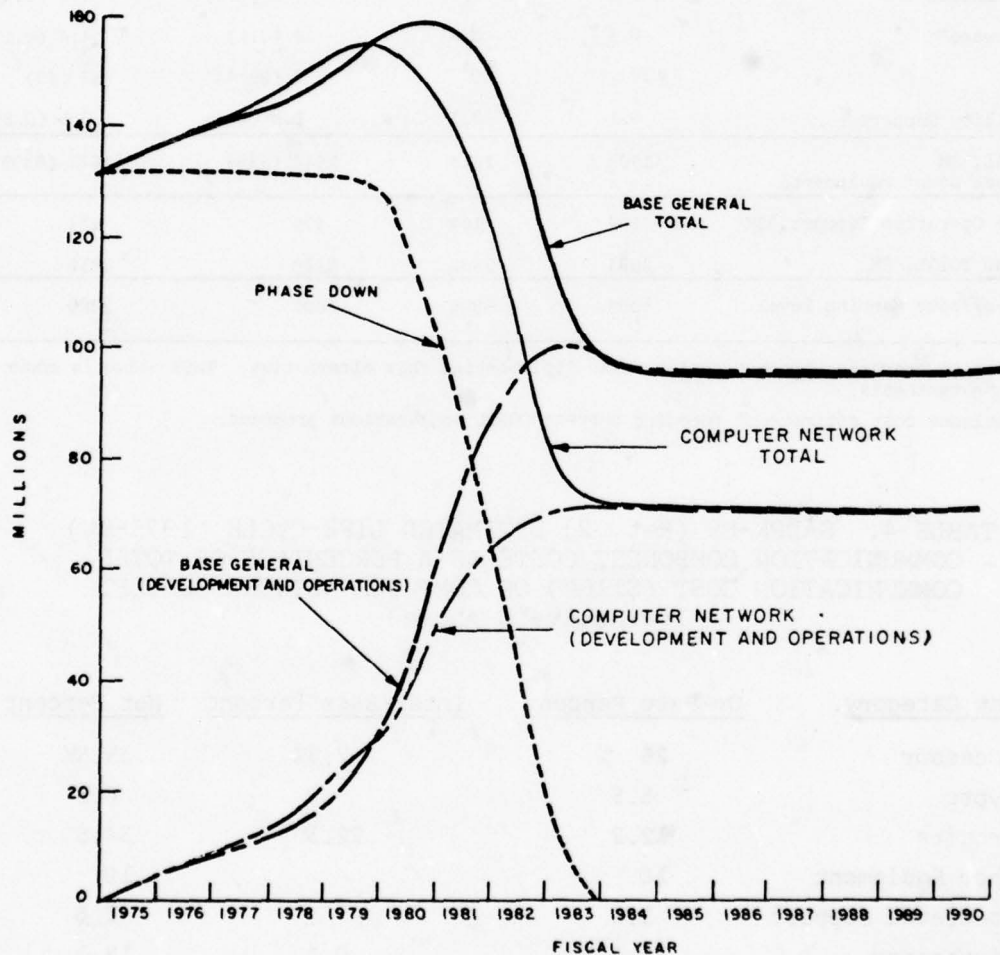

FIGURE 8. Comparison of SADPR-85 Total Program Costs (FY 1974 Dollars) for Base General and Computer Network Alternatives (Ref. 2)

The cost comparison among the four SADPR-85 alternatives considered indicates the following:

- There is no major variation in expected total life-cycle costs between the alternatives considered. The phase-down costs associated with alternatives 3 and 4 offset the savings incurred through using advanced technology.
- For alternatives 3 and 4 the principal cost uncertainty would appear to reside in the needed time to achieve successful operational status. Delays will seriously impact estimated phase-down costs. The principal leverage elements can be expected to be communication interfaces and ADP software.
- The O&M as a percentage of total cost per alternative also does not vary greatly; the projected variations in total cost are matched by corresponding variations in O&M costs through changes in manpower levels.

Figure 9 shows the expected system component costs (Ref. 2) for the Computer Network (alternative 4) in annual expenditures (not including the phase-down costs) in years after a go-ahead decision (postulated as 1974). Here the cost components are shown as additive increments. This figure replicates one in the SADPR-85 report but further decomposes the communications cost in order to contrast on-base and long-haul communications costs.

The long-haul inter-base communications and some portion of the on-base communications processor functions could be supported by a common-user switched data system such as the proposed AUTODIN II (Ref. 1). The rest of the on-base communications are provided by the very high speed local coaxial distribution system. The on-base portion shows a cost buildup at +4 years due to the purchase of the local coaxial system which tapers off to sustaining costs at +11 years. The inter-base communications and on-base communications processors will be leased and their cost builds up to a relatively constant annual level by +7 years when the system enters into significant operations.

Several revealing time dependent trends are shown in Fig. 9. During the initial phase the software costs dominate and then (it is

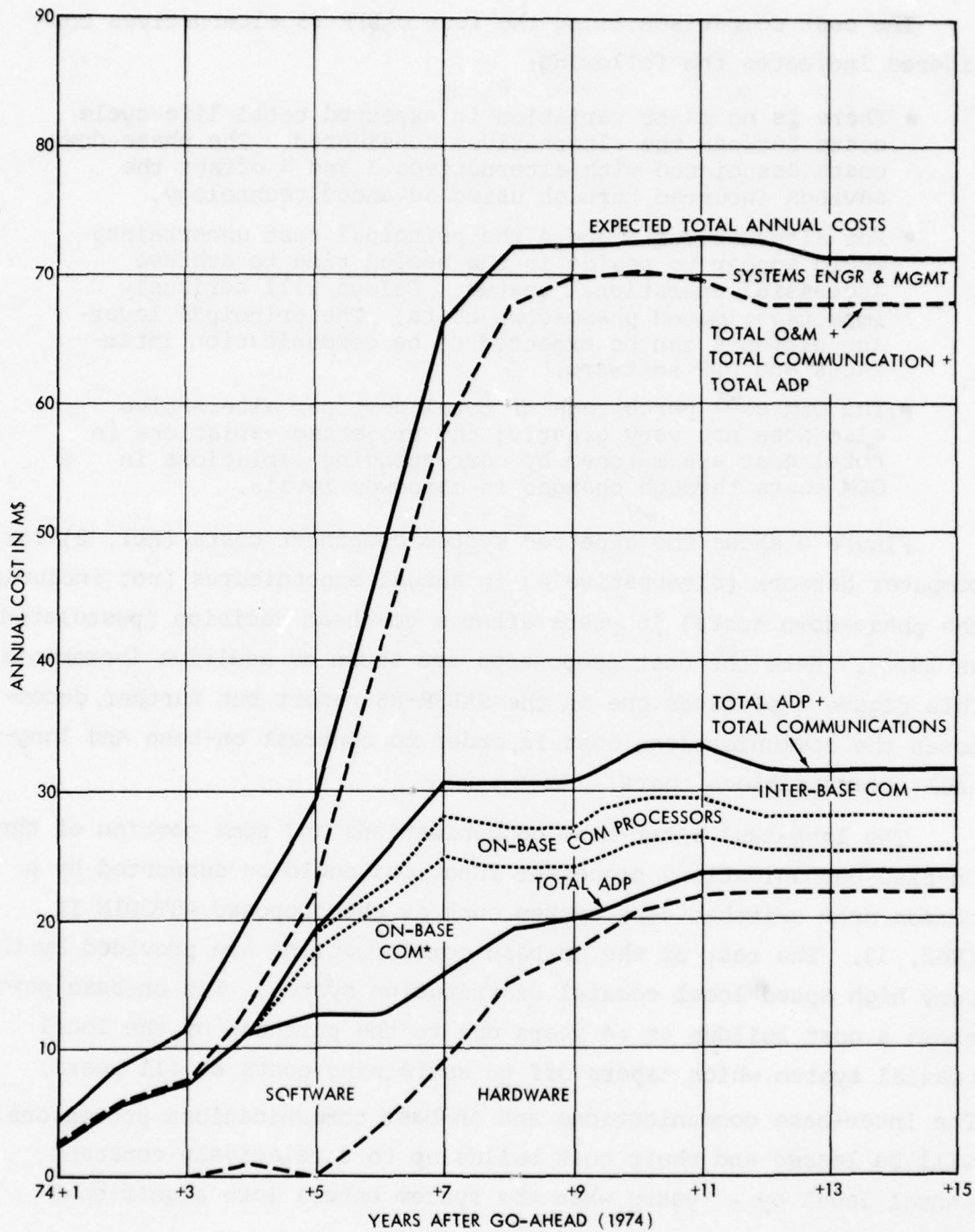

\*Does not include com processors; includes crypto, circuits, and support facilities.  
2-12-75-9

FIGURE 9. Component Cost Projections (FY 1974 Dollars) for SADPR-85 Computer Network Alternative (Ref. 2)

expected) trail off to a support role. The first significant hardware costs are those associated with acquiring local communication facilities, then followed by the ADP hardware acquisition. Long-haul communications costs are incurred last. During the very earliest portion of ADP hardware acquisition (+5 to +6), the long-haul plus on-base com processor costs match that of the ADP hardware but the sum of these costs is still dominated by the software and on-base com costs individually. Past this period (i.e., by +7) the system is beginning operations and the O&M costs dominate all else.

e. Discussion. In Table 5 aggregated costs for a few key years are shown in contrast with the total system life costs (not including phase-down costs). For each year (or total life cost) the aggregates are shown as a percentage of that year's (or total life) cost. With the exception of the communications aggregate, it is striking to see the relatively small fluctuation in aggregate percentage cost. Moreover, that communications component (i.e., inter-base plus on-base processor), which is capable of being provided by a common-user switched data system, does have a constant proportion of the annual (life-cycle) costs.

Although a critical technical element of the computer network concept, the communications direct cost element would not appear to have large leverage on system cost. It is the indirect impact of communications that is most significant. Timely availability with satisfactory performance (delay, error rate, throughput) of the communications portion is of considerable consequence. The communications common-user assignable portion of the system costs is on the order of one-third to one-fourth that of the ADP assignable costs. From this point of view, this portion of the communications cost appears significant. When the O&M costs (mostly personnel) are included, the common-user assignable communication costs drop to less than 10 percent.

TABLE 5. AGGREGATED PROPORTIONAL EXPECTED ANNUAL AND LIFE-CYCLE COSTS FOR SADPR-85 (Ref. 2) COMPUTER NETWORK ALTERNATIVE

<u>Cost Group</u>	(1980)	Year (1982)	(1988)	<u>Total Life Cost</u>
	<u>+6</u>	<u>+8</u>	<u>+14</u>	
ADP + Software	27%	26%	33%	33%
<u>Com Total</u>	<u>24%</u>	<u>16%</u>	<u>11%</u>	<u>14%</u>
On-Base	16%	7%	2%	6%
Inter-Base Plus On-Base Compressor	8%	9%	9%	8%
O&M + Sys. Engr.	45%	57%	54%	52%
(Sys. Engr.)	(12%)	( 6%)	( 3%)	( 6%)
Other	4%	1%	2%	1%
Total Expected Annual Cost, \$M/yr	48	72	72	\$838M

The ComSec requirements considered by the SADPR-85 study resulted in minimal costs. From Table 4, the ComSec component of the communication costs (crypto) amounted to 6.3 percent of the total computer network communications cost or equivalently 0.6 percent of the total cost. Those teleprocessing systems having more stringent ComSec requirements could experience considerable escalation in the communications cost. Reference 1 indicates that stringent ComSec requirements could double the communications cost. This would raise the common-user communication assignable costs to a par with ADP costs but these costs would still be dominated by the personnel costs.

The economic results of the SADPR-85 study are very illuminating for placing into perspective the relative roles of ADP, communications, and operating costs. However, it must be borne in mind that the systems considered are quite large and extensive. For significantly smaller teleprocessing systems (i.e., systems not of themselves aggregated into larger systems), the communication cost component can be a significantly larger portion of the cost.

In contrast to the previously discussed corporate merger example, the SADPR-85 concept represents a more comprehensive and advanced usage of teleprocessing functions. The users are considerably more distributed with considerably more "applications systems" consolidated. The Computer Network concept incorporates consolidation of computer functions which was not pursued in the corporate merger example. Although each regional processor uses a star-like topology, the regions themselves are interconnected with a distributed switched backbone network.

The Computer Network concept would support a well-defined common community of Air Force users (on a geographical basis). Further, the concept envisions implementation of a new system with a maximum of flexibility in design. As with the WWMCCS ADP buy, the possibility exists for common acquisition of processor hardware and associated operating systems at the Regional Processing sites. This will provide a relatively homogeneous ADP environment to the network, even more so than the WWMCCS sites as there is more replication of the Applications Programs. Finally, a central System Engineering focus can be established which would ensure compatible development of system standards, interfaces, protocols, and software support.

Although the SADPR-85 Computer Network concept enjoys the design advantages of starting from scratch with a new system, there are, nonetheless, several challenging areas of technical development and operational usage. These are not unique to the SADPR-85 concepts. Rather, they are generic to all teleprocessing systems with computer resource sharing features. These problems devolve from the usage of the system and relate to network control, resource scheduling, task priorities, and so forth (see Section III). Another major element will be the problems of multiaccess by diverse users of distributed data bases, e.g., file structures, accessibility, interactions, and up-dates, etc. Finally, as with the SATIN IV system discussed in Section III-B-1, there is a technically related problem to multilevel security although the level of protection required may be relaxed. In this regard, the emphasis would fall into the area of privacy of

privileged data such as personnel files. However, concern could develop about intelligence information that can be derived from data regarding supply, maintenance, status, and distribution of forces and assets.

5. Proposed AUTODIN II Network

a. Synopsis. The AUTODIN II (also referred to as IDN) is a proposal by the DCA to acquire an ADP subscriber-oriented, common-user, switched data transmission system (Ref. 1). By emphasizing quick response, AUTODIN II would provide inquiry response and interactive data transmission not available with AUTODIN I. In very general terms, the AUTODIN II concept is similar to the newly emerging Value Added Networks\* (VANs) such as TYMNET, Packet Communications, Inc., TELENET, and GRAPHNET. However, AUTODIN II will have to provide communication security features not present in the VANs. The basic technology concepts for AUTODIN II are derived from ARPANET and are thus similar to the expanded PWIN concept discussed previously. Whereas the principal objective of the (possibly expanded) PWIN\*\*

---

\* So called because these networks lease basic transmission facilities from the communications Common Carriers and add, at nodal points, switching and data subscriber interfacing services.

\*\* PWIN could be in use well before AUTODIN II would achieve operational status. The present planning concept is for the WWMCCS ADP sites to transition over to using AUTODIN II when it becomes operational and phase out the (expanded) PWIN assets not incorporated into the AUTODIN II network. This transition may become more challenging than expected depending on PWIN R&D evolution and accommodation to problems unique to WWMCCS ADP sites. For successful support to the WWMCCS ADP sites, AUTODIN II will have to support Type Ib features discussed in Section III-B.

is to perform operationally oriented teleprocessing experiments within the WWMCCS ADP community, the objective of AUTODIN II is to serve as a subscriber-oriented, general-purpose, common-user switched data communications network in support of and shared by many teleprocessing systems. Although AUTODIN II may be required to have the capability to support Type I applications, it is discussed here because its largest class of subscribers can be expected to be from the Type II applications area.

The AUTODIN II broad concept of design and operations is similar to the ARPANET philosophy wherein the data transmission, switching, and control functions are separated from the ADP and terminal functions. Host computers and user terminals would utilize the AUTODIN II as subscribers with the obligation of modifying as necessary their site hardware, software, and procedures in order to match the AUTODIN II interface standards, operating protocols, and flow control. This approach of data transmission is distinctly different from the conventional practice of acquiring communications\* as a component of any specific integrated computer/terminal teleprocessing system. In current systems, the data standards, protocols, and automated operating procedures are under the full control of the specific system, usually the host computer(s).

The AUTODIN II proposes to utilize a distributed set of packet-type switching nodes interconnected with 50- to 56-kbps backbone data transmission lines as shown in Fig. 10. Each subscriber (computer and terminal) accesses the system through one (closest) or more (for redundancy) switching nodes in the arrangement as shown in Fig. 11. Each subscriber will enter the switch through an access line to the Communications Access Processor (CAP) component of the switch. The

---

\* Usually dedicated lines leased from a Common Carrier telephone company and/or dial-up telephone lines. Higher than voice capacity (i.e., 4.8 to 9.6 kbps) transmission can also be leased on a dedicated point-to-point (i.e., nonswitched) basis.

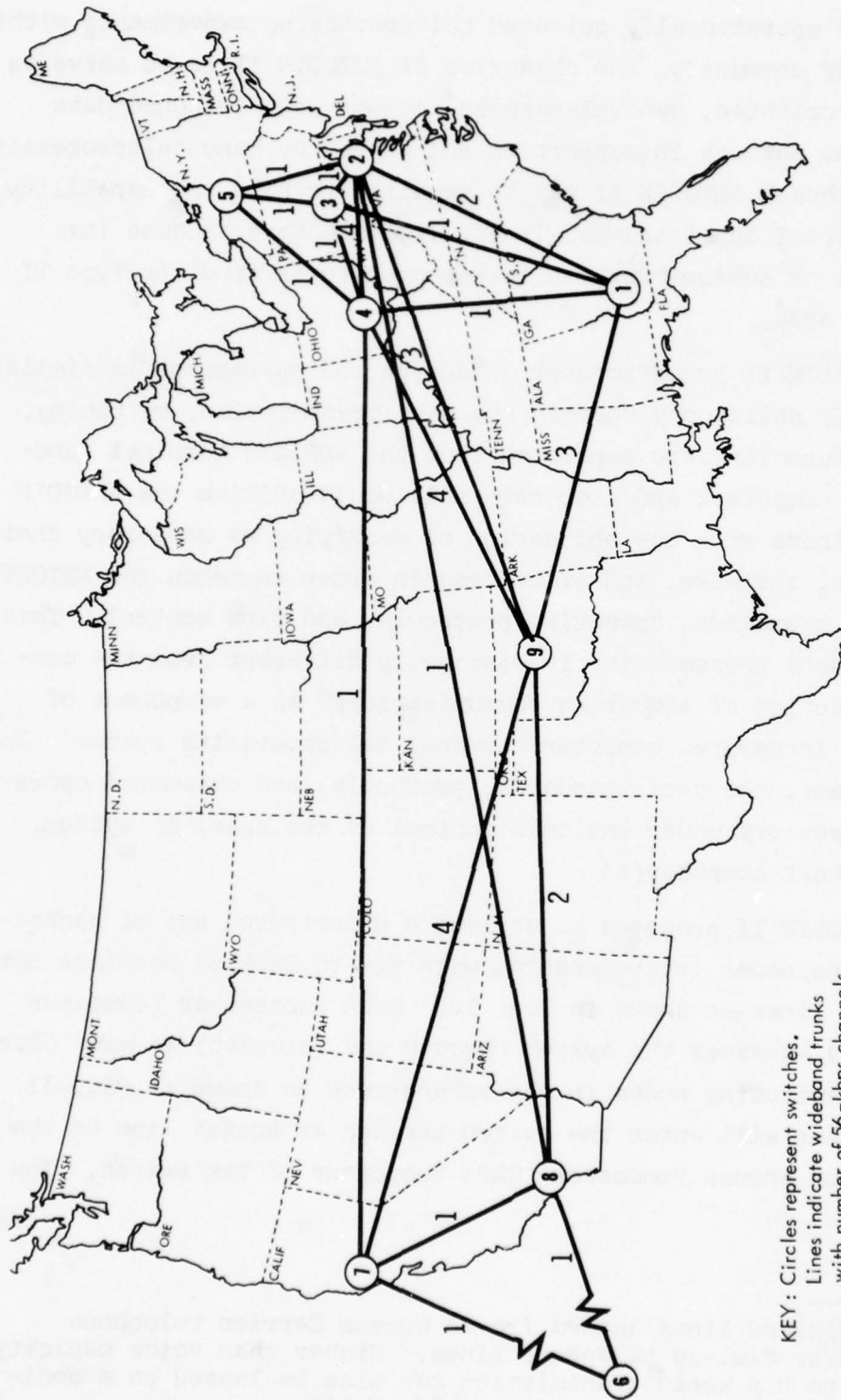

KEY: Circles represent switches.  
 Lines indicate wideband trunks  
 with number of 56-kbps channels.

2-12-75-10

Taken from material presented 10 July 1974 by the DCA to  
 DTACCS Advisory Panel.

FIGURE 10. Proposed AUTODIN II System (see also Refs. 1 and 5)

CAP will serve as the interface point and service a number of types of line and line speeds varying from 75 bps up to 9.6 kbps and special higher speed lines. The CAP will service synchronous and asynchronous lines with several of the more common data standards and protocols. Additionally, the CAP will have to exercise certain subscriber access control functions to achieve network flow control. It is not known yet whether polling-type access lines will be utilized.

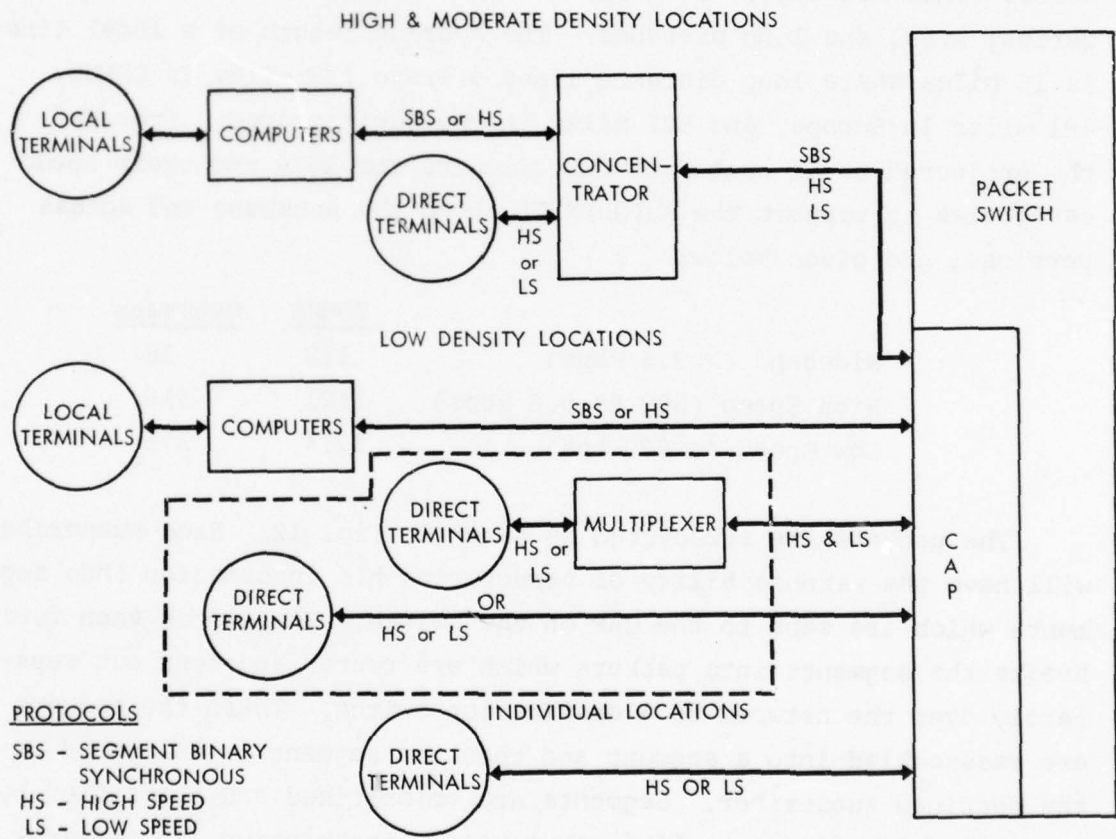

Taken from material presented 10 July 1974 by the DCA to DTACCS Advisory Panel.

2-12-75-11

FIGURE 11. Proposed AUTODIN II Access Arrangements (see also Refs. 1 and 5)

An interesting result of the study in Ref. 1 is the estimated projection of the number of DoD terminals and their location relative to ADP sites. In CONUS, there were estimated to be in the 1980 time frame 16,000 terminals located at ADP facilities and 1,800 located remotely from an ADP site. Overseas these numbers are reduced by a factor of 10. Additional information from Ref. 1 regarding projected numbers of computer subscribers is given in Section IV. For these terminals, Ref. 1 estimates the use in CONUS of somewhat in excess of 2,500\* access lines to the AUTODIN II backbone and 560\* access lines overseas. The access lines were broken into two categories, local and long distance. The average length of a local line is 15 miles while long distance lines average 118 miles in CONUS, 481 miles in Europe, and 922 miles in the Pacific area. From Ref. 1, the projected total number of DCS circuits for 1978 and their speed categories to support the AUTODIN II, both the backbone and access portions, are given below:

	<u>CONUS</u>	<u>Overseas</u>
Wideband (> 9.6 kbps)	118	16
High Speed (600 to 9.6 kbps)	1121	316
Low Speed (< 600 bps)	1714	375

The packets are structured as shown in Fig. 12. Each subscriber will have the responsibility of structuring his information into segments which are sent to the CAP on the switch. The switch then further breaks the segments into packets which are routed and sent out separately over the network to a destination switch. There the packets are reassembled into a segment and then the segment is delivered to the destined subscriber. Segments are prioritized and classified by length and function into five categories: interactive, inquiry/response, data base update, Bulk 1 and Bulk 2.

---

\* Many terminals will utilize more than one access line to the backbone network, either for redundancy or a high- and low-speed line.

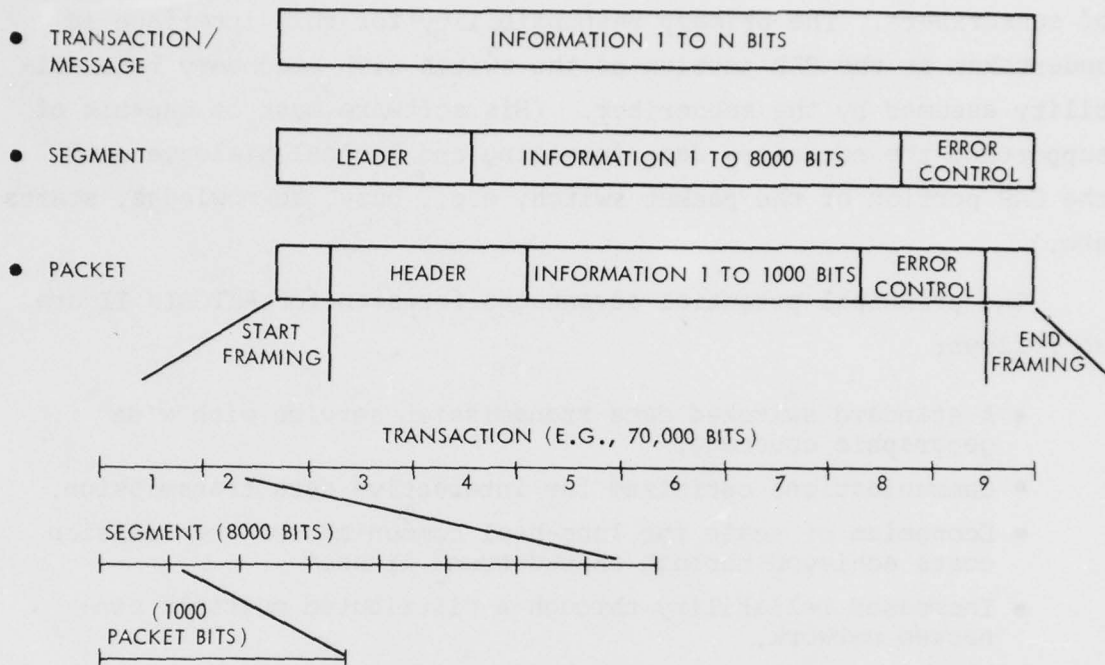

Taken from material presented 10 July 1974 by the DCA to DTACCS Advisory Panel.

2-12-75-12

FIGURE 12. Proposed AUTODIN II Data Handling (see also Refs. 1 and 5)

Segment assembly, error control, and certain other logical functions are the responsibility of the AUTODIN II network. Structuring the segments and providing a compatible operating interface to network standards (including the logical protocols for access control) will be the responsibility of the subscriber. Within the network (CAP access to CAP egress), multilevel ComSec is provided. The speed of delivery objective from acceptance of an interactive-type segment at the CAP to the start of segment delivery to the destination subscriber is one second. The objective for inquiry/response and Data Base update is on the order of seconds to a minute while the Bulk categories can be delayed up to hours.

b. Discussion. With the brief description of AUTODIN II given above, several observations are possible. Internal to the network, the data system is very homogeneous. However, the network, in order to be common-user, must be able to interface a very heterogeneous set

of subscribers. The primary responsibility for this interface is undertaken at the CAP portion of the switch with secondary responsibility assumed by the subscriber. (His software must be capable of supporting the necessary data formatting and logical dialogue with the CAP portion of the packet switch, e.g., busy, acknowledge, status, etc.)

The principal potential advantages foreseen for AUTODIN II are as follows:

- A standard switched data transmission service with wide geographic coverage.
- Communications optimized for interactive data transmission.
- Economics of scale for long-haul communication transmission costs achieved through shared trunk lines.\*
- Increased reliability through a distributed multiple connected network.
- Network design and growth depending principally on total aggregated network traffic with relatively low sensitivity to detailed traffic requirements between subscriber pairs.
- Facilitate ADP resource sharing: hardware, software, data bases, etc.

In addition to potential communication cost savings for small to moderately sized systems oriented to supporting interactive ADP functions, AUTODIN II type network would provide a facility for interconnecting sites from differing "systems," which only have intermittent need to exchange data. That is to say, the AUTODIN II could itself serve as an interface between teleprocessing systems. The current AUTODIN I system serves this purpose for the present batch and file-transfer-oriented ADP systems.\*\*

---

\* In the DoD context, additional savings in ComSec equipment may also accrue.

\*\* Or semi-interactive systems for which relatively long delays (minutes) can be tolerated.

Achieving a successful AUTODIN II is not without risks. These can be categorized as network oriented and subscriber impact. With regard to the network itself, the principal technical challenges appear to reside in the following:

- Achieving adequate multilevel security at acceptable cost
- Providing flow control and managing network capacity
- Establishing adequate subscriber data interface standards.

Critical to the successful acceptance by subscribers of any common-user data network are issues relating to the network impact on current and near-term future computer sites. Some of these are:

- Relative transparency\* of the network to the subscribing ADP facility
- Adequate availability of needed network capacity and throughput
- Minimum adjustment to site operating system software
- Minimum external impact on control of site assets-- hardware, software, and data bases
- Maintenance of site responsibility for its ADP tasking priorities, accessibility, data integrity (files)
- Heterogeneity in candidate subscriber ADP site configurations and workload.

Satisfactory transparency and associated throughput performance for one computer installation need not be acceptable for another. Nor is it clear that a given network-wide set of data transmission standards exists for which efficient throughput and transparency are mutually compatible for all or a majority of practical site configurations.

The subscriber-oriented problems described above pertain principally to already installed systems. With the emergence of a satisfactorily performing switched data network with sufficiently

---

\* A simply stated word which is as complex as "survivability" in implication and evaluation. This is discussed further in Sections V and VII.

widespread and accepted data standards, new ADP installations could more readily connect to the network. With normal growth and evolution at the older ADP sites, they too, in time, could be expected to reconfigure site hardware and reprogram software in order to avail themselves of a common-user data network.

c. Potential Economies of Scale Comparison. The costing data in Ref. 1 for the AUTODIN II concept are not final as the system configuration alternatives are still under study. However, the overall magnitude of the cost estimate is of some interest for preliminary comparative purposes with the SADPR-85 communications cost estimates. The purpose of such a comparison is principally to obtain some estimate of the economy of scale in potential cost savings involved in long-haul switched data communications. It is not unreasonable to attempt such a comparison as the communication networks resemble each other qualitatively, even though AUTODIN II is quantitatively much the larger. Both systems have comparable geographic span, and utilize 50-kbps trunk data circuits and packet-switching technology. The SADPR-85 communications support some 11 major sites of computer facilities while AUTODIN is sized to support a projected number of 375 ADP facility sites.\*

The component cost comparisons between SADPR-85 computer network communications and AUTODIN II are shown in Table 6. Here the SADPR-85 ten-year cost estimates are based on the 1976-85 period costs for comparison purposes. No discounted cost figures are used for either system. Note that a critical cost component is that associated with O&M manning costs for supporting ComSec requirements. In the SADPR-85 concept, the communications switching function is performed by the computer front-end processors collocated with the computer facility. Only the total facility O&M was costed. Consequently, the SADPR-85 cost estimates do not display any significant O&M costs in support of communications which is directed in support of the switches and

---

\*The projected future ADP technology and context used appear to be similar in both SADPR-85 and AUTODIN and are summarized in Section VI and Appendix B. This projection tends to be conservative.

ComSec. Applying the O&M to switch cost ratio from the AUTODIN II system to the \$33M of the SADPR-85 system yields for comparison purposes an estimate of \$8M. SADPR-85 shows no significant ComSec-related O&M, principally on the presumption that EATTON technology will be available. On the other hand, AUTODIN II costing does not make this assumption and uses conventional equipment. This incurs significant ComSec-related O&M costs. Utilizing EATTON on AUTODIN II could essentially eliminate \$198M ComSec O&M costs. If EATTON were not available to SADPR-85, then by applying the ratio of AUTODIN II ComSec O&M to equipment costs incurred in AUTODIN II to SADPR-85, \$59M in additional SADPR-85 O&M ComSec costs would be incurred. This is significant in that it increases the SADPR-85 communication costs by 40 percent.

TABLE 6. TEN-YEAR (1976-85) COMMUNICATIONS COST-ESTIMATE COMPARISON OF AUTODIN II AND SADPR-85 (Refs. 2 and 1)

<u>Item</u>	<u>SADPR-85 Computer Network Communications</u>	<u>AUTODIN II Tariff Alternative BI</u>
Projected Number of Major Computer Sites	11 major 114 overall	160 major 375 overall
Communications		
Circuits	\$27M	\$93M
Comm. Proc./Switch	\$33M*	\$776M
O&M (Personnel)	\$8M**	\$187M
ComSec		
Equipment	\$15M***	\$50M
O&M (Personnel)	\$59M**	\$198M
Total	\$142M	\$1304M
AUTODIN	--	\$240M
Other Costs	--	\$63M
AUTODIN II Total		\$1607M

\* Leased communication processors and other equipment procured.

\*\* SADPR O&M costs not separately identified. Estimates based on ratios of AUTODIN II O&M/switch costs and O&M/ComSec costs.

\*\*\* Estimate based on ratio of AUTODIN II ComSec equipment/circuit costs.

Using three different allocations of ComSec costs, the ten-year costs\* of Table 6 are divided by the expected number of major ADP facility sites and shown as a yearly average (ten-year costs ÷ 10) in Table 7. In making the scale comparison on a per-site basis, the assumption is made that overall terminal connections and communication load correlate directly with the number of ADP sites. However, the "size" of the sites should be taken into account. For example, in SADPR, the 11 major facilities support an aggregate of 103 bases, each having one large and two small minicomputers with a total aggregate CPU core memory per base of 192 kilobytes (= 1.536 megabits). Of the 375 AUTODIN projected sites, 215 are small sites with aggregated CPU core memory under 1.5 megabits. If for comparison purposes these small sites are discounted as not being major, then only 160 "major sites" are left.

TABLE 7. AVERAGE ANNUAL COST (in \$K) COMPARISONS PER ADP SITE

<u>Comparison Options</u>	<u>Average Cost/Year/Site</u>			
	<u>SADPR</u>		<u>AUTODIN II</u>	
	<u>11 Major Sites</u>	<u>114 Total Sites</u>	<u>160 Major Sites</u>	<u>375 Total Sites</u>
ComSec Costs Deleted	<u>618</u>	\$60	<u>660</u>	\$281
With ComSec (EKD)*	<u>755</u>	\$73	<u>691</u>	\$295
With ComSec (Conventional)	<u>1291</u>	\$125	<u>815</u>	\$348

\* Cost includes estimated Electronic Key Distribution equipment costs equal to conventional ComSec equipment costs without O&M.

Table 7 provides the comparison for different normalizing values of ADP sites. If the 114 major plus small sites of SADPR-85 are compared to the comparative equivalent number (325) of ADP subscribers to AUTODIN II, large discrepancies are revealed. In all likelihood, the proper comparison is between the large or major ADP sites (11 for

\* The present AUTODIN I associated costs are excluded from the comparison.

SADPR against 160 for AUTODIN) as these can be more likely expected to support the majority of terminal and small computer tasked ADP loads to the larger facilities. From this comparison it appears that if the cost of conventional ComSec O&M can be avoided, SADPR-type systems are sufficiently large and extensive that there may not be any significant overall savings in system costs by utilizing a common-user data network such as AUTODIN II (Ref. 9). Certainly, for systems significantly smaller than SADPR-85, the overall savings in communication system costs could be significant.

#### 6. Type II Sizing and Cost Model

a. Objective. An example of the possible economies of scale of Type II teleprocessing systems is a teleprocessing system sizing and cost model (Ref. 3) developed by the General Electric Company for the Office of Telecommunications Policy, Executive Office of the President. The objective of the effort was to provide an analytical tool to support policy formulation (e.g., ADP/communications regulatory issues). Of particular importance were identification and exploration of factors influencing economy of scale. The work was performed strictly in the civil sector with no DoD considerations. Nonetheless, it is representative of many of the issues for Type II DoD applications.

Reference 3 is summarized here principally to illustrate some of the major factors relating to system requirements data or inputs and the kinds of system output tradeoffs. The intent here is to show by example the kind of functional economic relations one would wish to develop. The specific numerical results\* quoted in what follows tend to be either limited or obsolete by the following developments since the original study.

---

\*Two principal "products" of the General Electric study were a computer model and instruction manual (Vols. II and III of Ref. 3). These in large part are still useful. However, the input data used to generate specific results are dated.

- Changes in communication cost schedules
- Changes in ADP "work" mix
- Changes in terminal characteristics (e.g., line speed and costs)
- Improvements in network optimization algorithms
- Rapidly changing balance between centralized and decentralized as well as "shared" delivery of ADP services.

The characteristics (e.g., break points, asymptotes) of the total and component cost versus "load" curves demonstrate the qualitative points of interest.

b. Configuration and Model Concept. In Ref. 3 generic teleprocessing systems of a centralized star type are modeled. The connection between the user terminals and a central processing site is through either a tree-like network with multi-drop lines with points of concentration or a ring-like network wherein multiple loops fan out from a central site. The model presumes that in any system all the terminals are under integrated control with central management. Any one terminal "talks" to (or through) but one computer. From this basic model, the economic tradeoffs of multiplicity of such systems with specialization in ADP job type and/or geographic span can be studied.

The types of parameters used in or produced by the model in Ref. 3 include:

- The numbers and types of terminals required in each served city
- The numbers and types of processors in each computing center
- The memory size for each processor
- The numbers and types of memory extension devices and controllers for each processor
- The numbers and types of file machines and controllers for each center.

Six types of teleprocessing computerized tasks were used to generate data flow and processor loading. These were:

Two Message Switching Tasks: The first task involved short information messages and the second, TWX-type messages.

An Inquiry Task: This task was similar to a stock brokerage price quotation task.

An Order Entry Task: This task was similar to that required for a stock purchase or sale.

Two Remote Batch Tasks: The two tasks studied involved a customer billing task and a file maintenance task.

c. Typical Results. The computer model was used to design and develop the cost of several differing types of teleprocessing systems. Although these systems are basically of the star configuration, they differ in ADP task mix, geographical extent, and subscriber (terminal) distribution. Reproduced from Ref. 3 are example results. All of the curves shown are plotted in abstract normalized units; consequently, the qualitative characteristics of the curves are of interest but absolute values cannot be taken literally. More importantly, comparisons between the curves cannot be made as the normalizing procedures vary from figure to figure.

For a system with various levels of activity, the model of Ref. 3 lays out a network and sizes and costs subscriber terminals, communications, and the ADP central computer system or central station. The level of activity or "load level" is computed by a submodel which relates the mix of the six types of tasks listed above to a number of "fundamental" unit tasks. The unit costs shown in Figs. 13, 14, and 15 are obtained by dividing the overall cost by the number of unit tasks at a given load level. Thus, load level and unit costs cannot be directly compared between different system types.

The first example shown in Fig. 13 demonstrates the unit cost and its components as a function of load level for a large central computer center located in the middle of the U.S. (i.e., St. Louis) providing service to the 50 largest cities. The task mix used was 100 message-switching tasks to three remote batch tasks. The load level origin of unity was only indicated as that which would produce

reasonable (criteria not quantified) utilization of equipment. Verbal inquiry indicated that a load level of 10 might correspond to the General Electric time-sharing system level of operations about 1974, a very high level of operations indeed. From Fig. 13 the terminals, modems, and local loops dominate system cost. There exist large potential savings\* in these costs through upgrades in the terminal and modem configuration. In this example, overall costs are relatively insensitive to long-haul communication costs although there is as much as two-to-one variations in the communication portion depending on transmission network.

Another example of a teleprocessing system examined in Ref. 3 was of a corporate owned (in-house) system processing all six tasks but with strong emphasis on the interactive tasks listed above. The remote batch tasks were deferred to after business hours (Fig. 14). The system geographic coverage is similar to the previous example. Here load level (level of transactions) is related to the number of central processing "systems" needed at the central location. For medium-sized systems, communication costs dominate. As the load level increases, the dominance of communications, terminals, and central systems costs changes.

A final example considers a system similar to the preceding example but compares the consequences of sharing a communications subnet. Again, a star system (or systems) centrally located (in "St. Louis") serves the 50 largest cities. For this example, the load level is based on two message-switching tasks and one on-line data processing task (e.g., order entry). The other on-line task and the two remote batch tasks were dropped from the ADP work mix. In Fig. 15 the unit costs for one system with its own communications are compared with and shown to exceed the costs incurred by one system sharing communications with nine other systems. Having all central processing systems collocated emphasizes cost savings in

---

\* Costs used in Ref. 3 are from a 1972 cost data base.

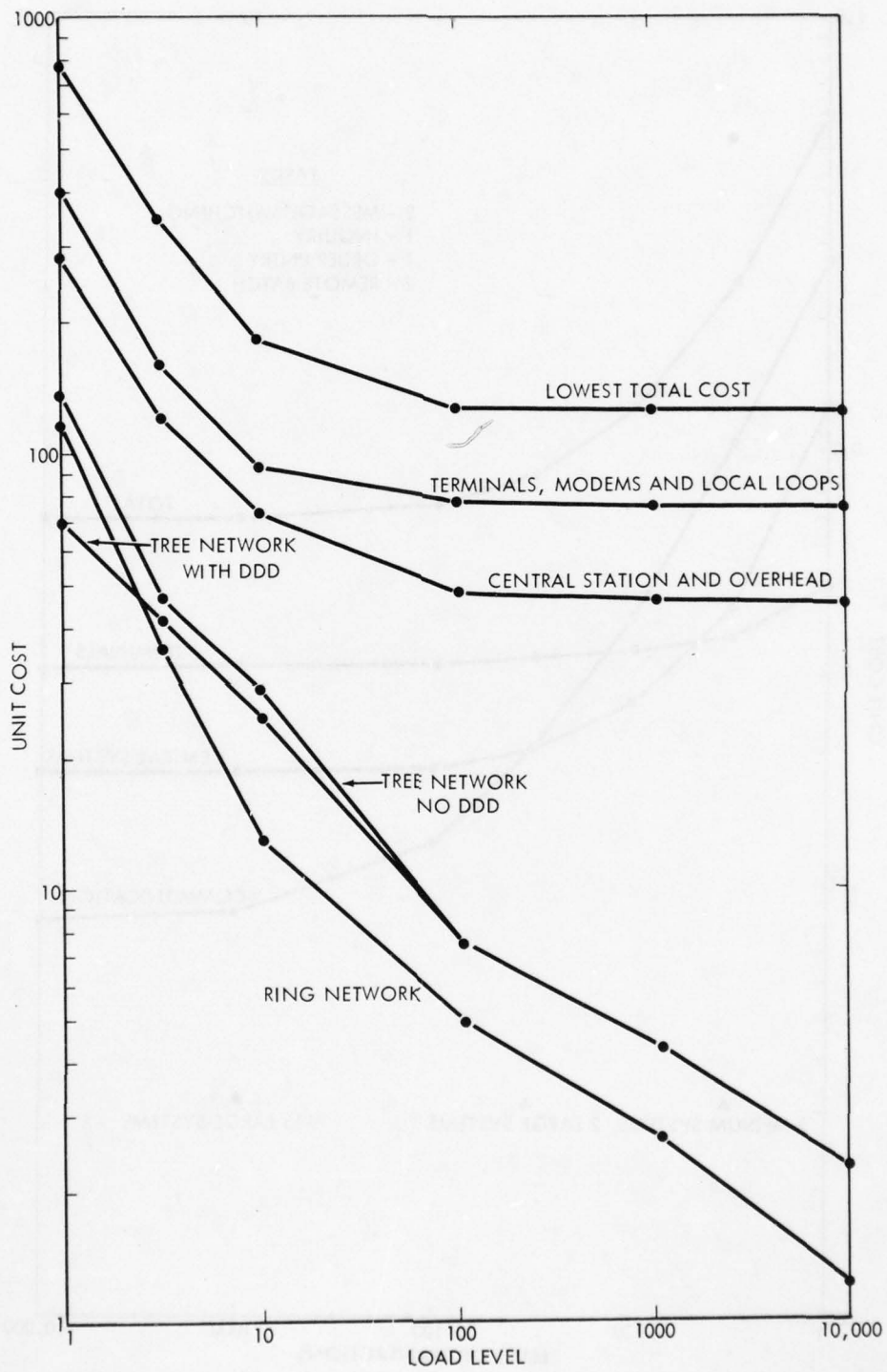

8-5-75-2

FIGURE 13. Centralized System Unit Costs

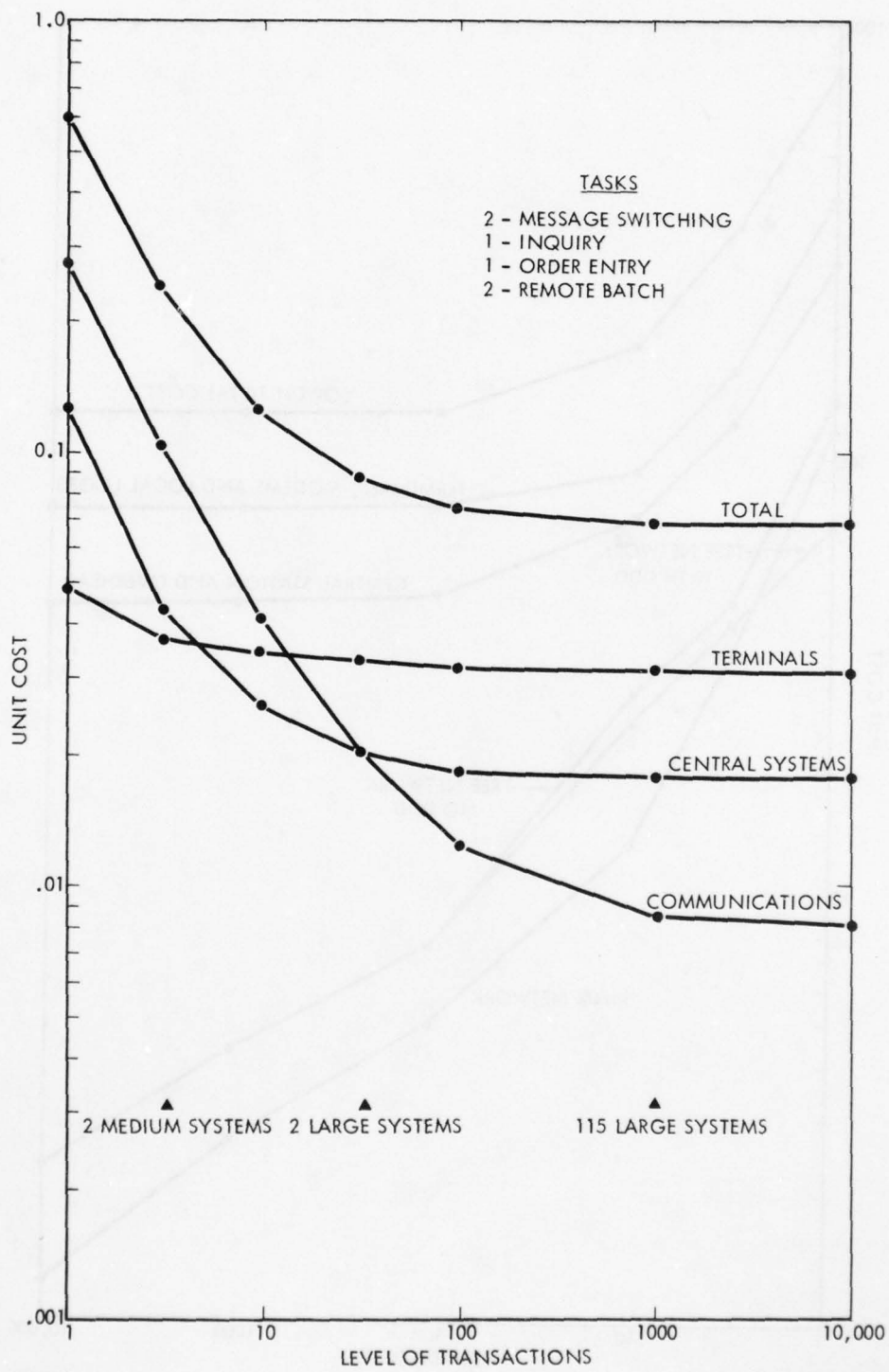

8-5-75-3

FIGURE 14. In-House System Unit Costs

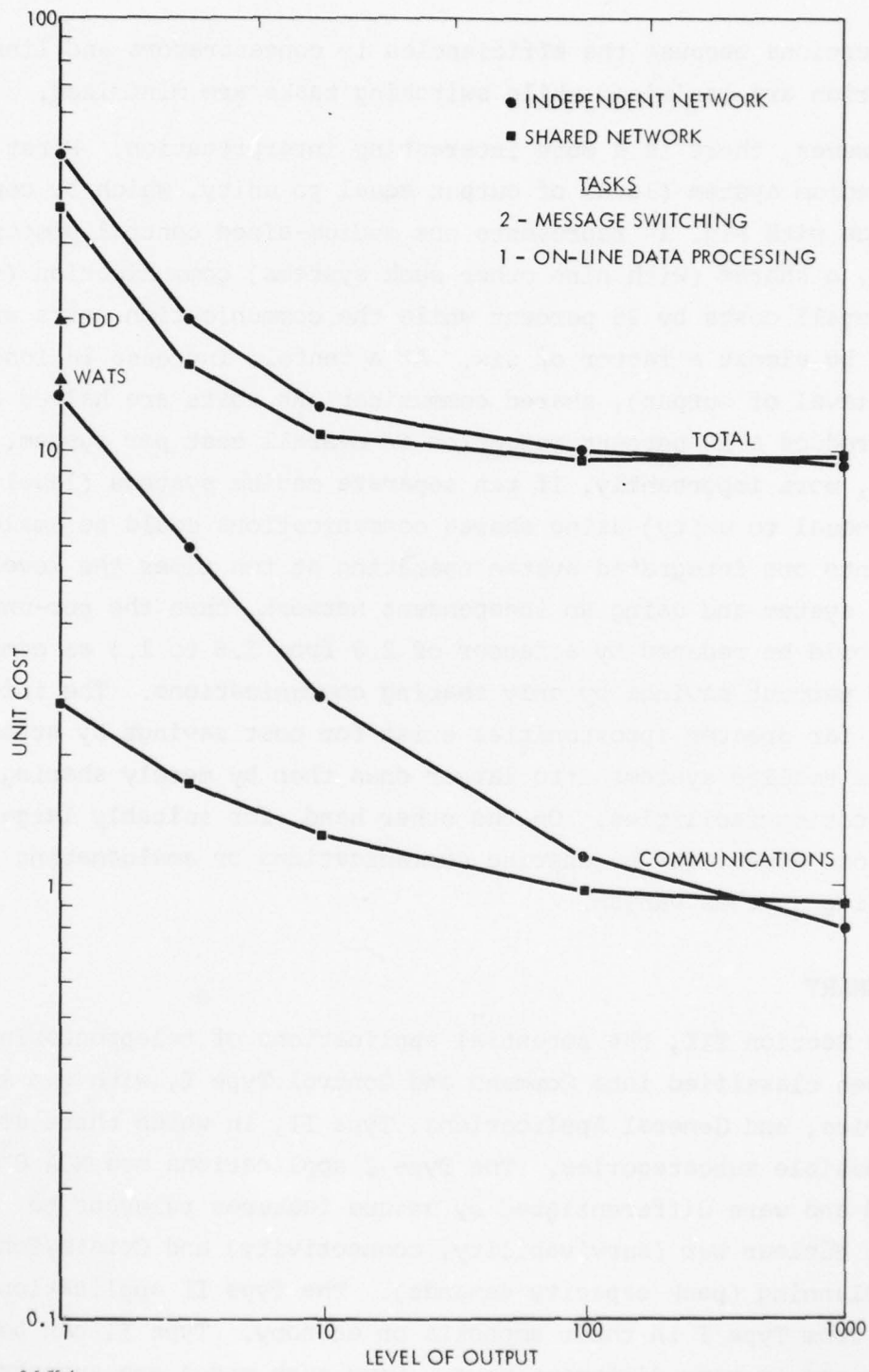

8-5-75-4

FIGURE 15. Communications Network Unit Costs

communications because the efficiencies in concentrators and line utilization are maximized while switching tasks are minimized.

However, there is a more interesting interpretation. First, for a medium system (level of output equal to unity, which by correspondence with Fig. 14 represents one medium-sized central processor system), a shared (with nine other such systems) communication (sub)net cuts overall costs by 25 percent while the communication costs are reduced by almost a factor of six. At a tenfold increase in load level (level of output), shared communications costs are halved and still produce a 15 percent reduction in overall cost per system. However, more importantly, if ten separate medium systems (level of output equal to unity) using shared communications could be amalgamated into one integrated system operating at ten times the level of any one system and using an independent network, then the per-unit costs would be reduced by a factor of 2.8 from 3.6 to 1.3 as compared to a 30 percent savings by only sharing communications. The inference is that far greater opportunities exist for cost savings by attempting to merge smaller systems into larger ones than by merely sharing communication facilities. On the other hand, for suitably large systems, cost advantages by sharing communications or amalgamating processing systems vanish.

#### D. SUMMARY

In Section III, the potential applications of teleprocessing have been classified into Command and Control Type I, with two subcategories, and General Applications, Type II, in which there are many possible subcategories. The Type I applications are NCA C<sup>3</sup> focused and were differentiated by unique features relevant to General Nuclear War (survivability, connectivity) and Crisis/Contingency Planning (peak capacity demands). The Type II applications differ from Type I in their emphasis on economy. Type II can be subcategorized in many different ways. Four such modes are suggested: Organizational, Regional, Standard, Technical and Security. These

AD-A067 281

INSTITUTE FOR DEFENSE ANALYSES ARLINGTON VA SCIENCE A--ETC F/G 9/2  
TELEPROCESSING ISSUES IN THE DEPARTMENT OF DEFENSE.(U)

JUN 75 J M AEIN, T C BARTEE, R A FINKLER DAHC15-73-C-0200  
IDA-S-445 IDA/HQ-74-16813 NL

UNCLASSIFIED

2 of 3

AD  
A067 281



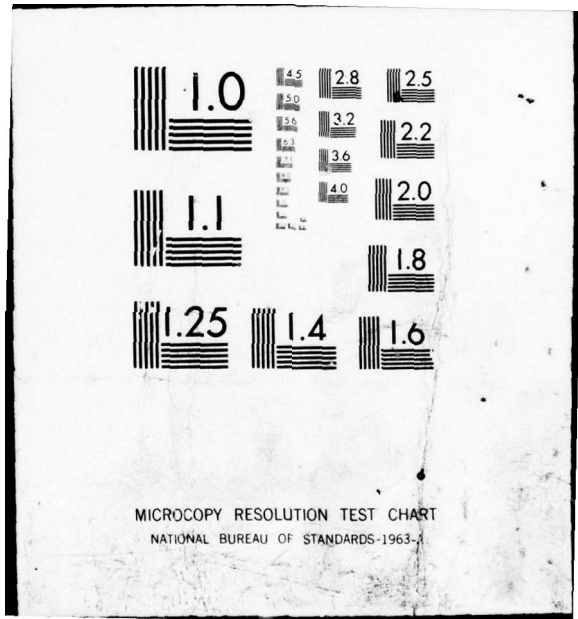

MICROCOPY RESOLUTION TEST CHART  
NATIONAL BUREAU OF STANDARDS-1963-A

of these modes of aggregation are also possible and are desirable. With the exception of the technical mode, existing ADP systems in DoD (mostly of the reporting type) reflect all of the other four modes. With the advent of teleprocessing, the technical mode (ADP activities closely related in their technical features) will gain importance. No scientifically well-grounded basis has yet been found for matching the "best" aggregation of systems by mode.

Technically useful factors for categorizing teleprocessing networks are the following:

- Connectivity and data exchange requirements
- Degree of heterogeneity between ADP sites
- Type of data service (interactive or bulk)
- Capacity (volume, speed)
- Special features (security, priority)

In Table 8 a detailed contrast between Type I and Type II applications and potential problem areas is presented. Proposed example systems dedicated to each application area Type Ia, Ib, and II are provided. Within the Type II area a common-user switched data transmission network is presented. An important issue is the relation between system realization and the applications area. Should Type Ia, Ib, and Type II be realized by separate (dedicated), mixed, or integrated facilities? If or where separated, what are the interfaces and interoperation mechanisms? As yet there is no technically satisfactory way to ensure answering such questions.

Without any positive management action, it is likely that the current operating Type II ADP systems will tend to retain their present affiliation and attempt to upgrade their capabilities by drawing on new technology as individual systems. This approach does not seek to maximize ADP cost savings through aggregation and sharing of ADP functions. At some point in time, the cost of a hands-off approach will be excessive. When this point is reached, it is reasonable to expect that evolving operational systems whose affiliations are sufficiently close will have strong economic motivation to merge, confederate, or

TABLE 8. CONTRAST OF TYPE I AND TYPE II APPLICATIONS AND POTENTIAL PROBLEM AREAS

APPLICATION AREA	EXAMPLE SYSTEMS	CHARACTERIZATION	PROBLEM AREAS
Type Ia	SATIN IV	<ul style="list-style-type: none"> <li>• General War C<sup>3</sup> - survivable short-delay transactional messages. Limited number host computers; specialized application programs. Data naturally packeted. Homogeneous system design.</li> <li>• AUTOVON-derived circuits with AutoDial with adaptive routing/switching.</li> <li>• Economic aspects secondary to survivability and speed/connectivity. Not general-purpose-oriented.</li> </ul>	<ul style="list-style-type: none"> <li>• Survivability-multimedia transmission (Sat VLF, etc.). Integration at CPs and force units.</li> <li>• WMMCCS and other C<sup>3</sup> system integration.</li> <li>• Logical relation between AUTOVON/SATIN IV switch.</li> </ul>
Type Ib	Expanded PWIN	<ul style="list-style-type: none"> <li>• WMMCCS ADP-C<sup>3</sup> internet. For (1) cont. of ops, (2) distributed data base, (3) contingency planning. ARPA derived technology hierarchy of prioritized services, RJE and transactional.</li> <li>• Economic aspects on par with functions. May require large peak factor for crises management.</li> <li>• Hardware homogeneous, software, and configuration heterogeneous.</li> </ul>	<ul style="list-style-type: none"> <li>• Command prerogatives, data file standards, responsibility, mixed access, multilevel security.</li> <li>• Site software, network interface, and schedules.</li> <li>• System unique constraints.</li> <li>• Capacity priorities/load peaking.</li> <li>• Remote host computer science.</li> </ul>
Type II	SADPR-85 ALS MACIMS SPEEDEX STOCK POINTS	<ul style="list-style-type: none"> <li>• Emphasis on cost-effective ADP support to multitude of military support activities e.g., supply, logistics, personnel, finance, etc.</li> <li>• Primarily stand-alone facilities evolving towards incorporating remote terminal activities. Each system tends to be internally homogeneous in hardware and software and externally very heterogeneous.</li> <li>• System configuration and operation closely coupled to activities supported.</li> </ul>	<p><u>General</u></p> <ul style="list-style-type: none"> <li>• Control of proliferation of systems and redundant overlap in function.</li> <li>• Aggregation of system use, function and design.</li> <li>• System interoperability.</li> </ul> <p><u>Technical</u></p> <ul style="list-style-type: none"> <li>• Multilevel security and privacy.</li> <li>• Econometric methodology and evaluation.</li> <li>• Test and evaluation, system growth and evolution.</li> <li>• System technology transfer, switches, front-ends, software, etc.</li> </ul> <p><u>Plus To a Lesser Degree</u></p> <ul style="list-style-type: none"> <li>• Development of interface standards.</li> <li>• Multisystem shared flow control and network control.</li> <li>• Software impact and cost allocations.</li> <li>• Network/subscriber responsibilities.</li> <li>• Planning, requirements and acquisition roles and responsibility.</li> <li>• Impact on ADP suppliers vice common or specialty data carriers.</li> <li>• Policy for (1) user acceptance or subscription, (2) separate networks and their relationships to common user, each other.</li> <li>• Needs adequate R&amp;D program.</li> <li>• Hybrid fast-circuit and packet-switching technology for mixed interactive and bulk data traffic.</li> </ul>
Common User Data Network	AUTODIN II	<ul style="list-style-type: none"> <li>• Subscriber-oriented common-user-switched digital data network. Hierarchical switched network of data packets with set of standard terminal, host interfaces.</li> <li>• Strong separation of ADP site operation from "standard network" backbone.</li> <li>• Emphasis on economic aspects, throughput, savings in scale. Provide cost-effective capability and connectivity for small to medium "systems."</li> <li>• May provide savings in ComSec costs.</li> <li>• Allows shared resource and ADP systems inter-operation for 1980-90 ADP environment.</li> <li>• May provide method for interconnecting or interfacing independent teleprocessing networks requiring intermittent traffic exchange.</li> <li>• Provide multiple functions: e.g., query/response, transaction, RJE, and file transfer.</li> <li>• Must operate in very heterogeneous environment.</li> </ul>	

otherwise attempt to reduce costs through mutual sharing of assets. Alternate to or in parallel with this approach, DoD can promote development of management tools (requirements), technology (subscriber-oriented networks) and research (multilevel security and data base management) in order to foster earlier aggregation of ADP systems by natural means or, if desired, begin to lay the basis for setting specific objectives for ADP aggregation.

For Type II applications, preliminary cost data taken from a proposed large and geographically extensive teleprocessing system for Air Force base level ADP (SADPR-85, Ref. 2) were contrasted with similar preliminary costs data for a proposed switched common-user data transmission plant (AUTODIN II, Ref. 1). The salient features from Ref. 2 would indicate the following:

- Inasmuch as the proposed system will replace an already existing set of equipments, the estimated cost of sustaining and then phasing down the existing facilities while bringing on to line the new system is as large as the projected cost of the new system. Consequently, overall costs are extremely sensitive to delay in bringing a new system on line.
- Not including the cost of phasing down the old system, O&M amounts to over 50 percent of life-cycle costs for the new system.
- With reduced or no ComSec requirements (e.g., EATTON technology), communication costs are well under half the ADP costs. For the total system, including O&M costs, the communications costs account for 15 percent of the total. When old system phase-down costs are included, the communications costs drop to 7 percent of the total.
- ComSec O&M costs are very significant. If conventional ComSec equipment is required, then O&M in support of this equipment will increase the projected communications costs by at least 40 percent.

Preliminary comparison for potential economies of scale between the SADPR-85 communications and AUTODIN II reveals that without ComSec O&M costs associated with current equipments, a common-user data transmission system does not provide significant savings in communications costs over systems as large and extensive as SADPR-85. If

conventional ComSec O&M costs are incurred and if a common-user transmission system can provide multilevel security, then a common-user (secure) data transmission system could possibly provide up to 40 percent reduction in communication costs in comparison with a dedicated system such as the SADPR-85 communications. In any event, for large systems, communications costs are not dominant.

These preliminary results demonstrate the cost impact of security and highlight an important cost issue. "Should use of a common-user data communication system be dictated for potential savings in communication costs at the possible risk of delaying overall system operations and incurring continuing (increased) costs in phasing down an older system?" There is no easy answer to such a question. Clearly, the preexistence of a successful and secure common-user data communications system would strongly motivate tailoring a SADPR-85 system to its use. On the other hand, if no satisfactory common-user data transmission system existed prior to a SADPR-85 system implementation, the opportunity might exist to grow one\* out of the dedicated data transmission component of a SADPR-type system.

---

\*This is precisely the evolutionary route of the TYMNET (Ref. 11), which grew out of the TYMSHARE system.

#### IV. REQUIREMENTS AND ASSETS

##### A. REQUIREMENTS

In this section, an overview of the current ADP usage and requirements "data base" is presented with the object of placing in perspective the relationship of current requirements data to those needed for the design and management of teleprocessing systems as well as policy formulation. The focus in this section is on the Type II, General Applications, teleprocessing area. The Type I requirements formulation follows from a more narrowly defined activity of mission function in support of NCA direction of the military forces. However, much of the technically oriented discussion relating to requirements for system design is applicable to Type I applications.

The present ADP system requirements data can be characterized as follows:

- List inventories of ADP Hardware Assets
- List inventories of Reporting or Functional Information Systems
- Preliminary models of ADP task load and data traffic flow.

This section provides examples and discussion of these categories.

##### 1. Acquisition Procedure for ADP Hardware

It is useful to review and characterize the present acquisition procedure for ADP assets with DoD. It is this process which, to date, determines the need and scope of data required for formulating current ADP requirements. An ADP site or prospective site within the DoD generates a requirements justification, an applications description, an acquisition plan, and a technical specification for some ADP

hardware\* items. This request is then reviewed for approval through the acquisition chain to which the installation belongs usually within a military department or DoD agency. The approval level needed to proceed with acquisition is generally keyed to the cost of the buy. Most full size computers or a large buy of small computers or associated equipment are required to traverse the full approval chain to include review by OSD Comptroller personnel. For any particular approved request, it is then reviewed to ascertain if the technical specification can be satisfied by any ADP assets held in a surplus pool. If the request cannot be supported with surplus ADP assets, the requirements, specifications, and any special purchase conditions are forwarded to the General Services Administration (GSA) who then acts as the Procurement Agent\*\* for DoD. A Request for Proposal (RFP) is issued to industry, the received contractor bids are then technically evaluated by the appropriate DoD military department,\*\*\* and a ranking of the bidders is provided. GSA then proceeds with the negotiation for procurement and delivery of the equipment.

Following satisfactory installation and acceptance of the equipment at the ADP site, it is usually the responsibility of the site to install the applications programs and integrate as a functional component the procured equipment into the site configuration. This can be a significant software development effort in which the site can be aided by one of the centralized software support agencies within the military departments or on contract with a commercial software consulting firm.

---

\* This also includes the operating system software to enable the device to function but not the application software.

\*\* The GSA procurement role is dictated by act of Congress. For specialized systems, DoD can obtain a delegation of authority from the GSA.

\*\*\* Usually that department responsible for the site generating the purchase requirement.

## 2. Discussion

The important feature of the above process is the development of need by the individual ADP user. The responsibility for acquisition and operational integration is divided between the GSA as purchasing agent and the user's ADP site facility. This requirements and procurement process appears to have been reasonably satisfactory. However, with the exception of a listing of major computer assets by type, manufacturer, and location, the technical specifics of the functional ADP systems are not easily visible at higher management levels. The functional technical system descriptions usually are resident with the particular ADP system they describe. Moreover, there is as yet no uniform or standard manner of description although there is momentum developing within DoD toward developing a standard set of descriptions (Refs. 12 and 5).

Perhaps of even greater significance is that the current requirements process has developed within the context of stand-alone computer facilities. Each facility generates an estimate of its own work load and site processing capability in order to determine inadequacies in task throughput and thus generate a specification and justification for an ADP hardware procurement. There have evolved analytical and simulation methodologies along standard ADP task models\* for quantifying requirements and numerically evaluating candidate machine performance in satisfying the specification of need.

With varying degrees of success this approach has been quantitatively adequate. However, with the advent of teleprocessing systems containing off-site interactive terminal capabilities, the current methodology has deficiencies in at least the following areas:

- The detailed interaction with communication transmission facilities
- Communications induced ADP tasks (e.g., line control, distant user protocol)

---

\* These analyses are structured principally for third-generation on-site CPU, memory, and peripheral interaction.

- Interactive distant user tasks
- Site architecture options (e.g., front ends versus larger CPU)
- System architecture, on-site versus off-site processing.

In fact, the problem is compounded by the lack of even a definition or standardization of what primary requirements data are needed to support an evaluation methodology. There are currently individual separate activities within industry and government working on this problem. Progress has been made principally only with centralized computer/terminal systems with dedicated communication support. The technical aspects of these issues are discussed further in Sections V and VII.

## B. ADP ASSET INVENTORIES

### 1. Computer Asset Lists

The GSA, in its role as the U.S. Government-wide centralized ADP procurement agent, maintains a (computerized) listing of ADP assets by manufacturer, type, and location (Ref. 13). Each department and agency of the DoD keeps similar listings of its own (Ref. 14). The GSA data have been aggregated by departments of the Government into basic categories of (1) General Management and Special Management, (2) Owned or Leased, (3) Cost and Size, and (4) Single and Multiple CPU systems. Teleprocessing aspects and categorizations have not as yet been introduced into the GSA-maintained ADP data base. Principal ADP usage to date has been in stand-alone computer facilities. However, IRS and Social Security are currently operating teleprocessing systems. With the growing utilization of teleprocessing (including that by GSA itself), it can be expected that GSA will begin to incorporate teleprocessing related data in its ADP listings.

The GSA data pertinent to Type II applications are principally in the General Management category. The data from the GSA inventory aggregation are useful in establishing the current level of ADP usage in the Government. The following figures are taken from Ref. 13.

Figure 16 shows the time-dependent growth of Government-owned computers versus leased computers. The overall number of computers in use has grown about 17 percent between 1968 to 1973 but the balance between owned and leased computers has changed from about 1:1 in 1968 to more than 2:1 in favor of Government ownership by 1973. This clearly indicates that in the near future existing ADP facilities within Government cannot be expected to be replaced at the same rapid rate as in the past when most of the assets were leased. Thus, considerable emphasis will be placed on compatibility between new ADP components or adjunct (sub)systems and the existing facilities.

Further categorizing the existing ADP facilities, GSA shows in Fig. 17 the percentage in a given purchase price range (hence size) as a total number of owned systems and the resulting percentage of the Government inventory commanded by that class of computer. These data demonstrate the concentration of Government-owned ADP facilities in large computers although there is a growing inventory of minicomputers. This further emphasizes the need to consider compatibility between planning new systems and activities with current facilities.

In Tables 9a and 9b a usage breakdown by Government department and CPU categorization is provided. Table 9a defines the CPU categories. Categories A and B have one CPU, Categories C, D, and E have on the average of three CPUs, Category F has on the average of six CPUs and Categories G, H, and I have an average of seven CPUs. Table 9b shows that within the Federal Government, DoD is the largest single user of ADP followed by AEC and NASA. The categorization used is not explicit as to systems with teleprocessing activity nor the details of such activity. Of the categories defined only Categories F through I would appear to contain systems with potential teleprocessing function. Within the 3460 DoD listed systems, only 22 fall within Categories F through I.

These data reconfirm the known fact that most present ADP systems are "Stand-Alone." However, these data do not reflect the emerging trend of attaching remote terminals via dedicated or dial-up

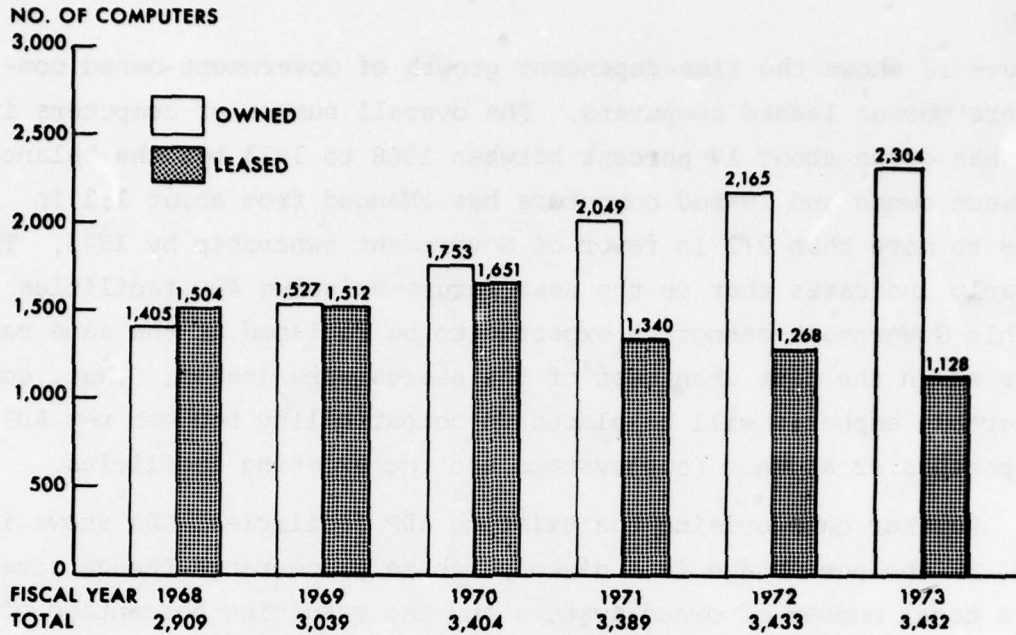

FIGURE 16. Computers in the Federal Government (General Management Classification) (Ref. 13)

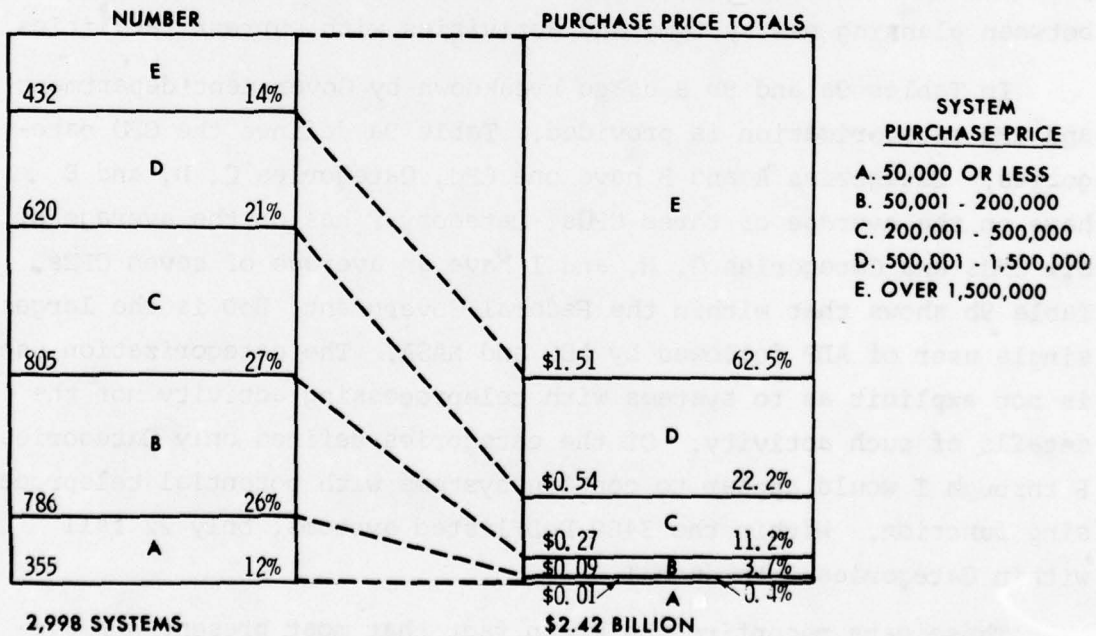

FIGURE 17. Computer Systems by Purchase Price Range (General Management Classification) (Ref. 13)

TABLE 9a. COMPUTER SYSTEM TYPES BY AGENCY (Ref. 13)

AGENCY	SYSTEM TYPE	CODE										TOTAL
		A	B	C	D	E	F	G	H&I			
ATOMIC ENERGY COMM.		1,039	54	18	10	6	8	1	-	-	-	1,136
AGRICULTURE		57	4	-	-	-	-	-	-	-	-	61
COMMERCE		137	14	4	-	2	-	-	2	-	-	159
GENERAL SVCS. ADMIN.		27	1	1	-	-	-	-	-	-	-	29
HEALTH, EDUC., & WELFARE		71	9	1	1	1	1	1	-	-	-	85
INTERIOR		45	1	3	-	1	-	-	-	-	-	50
NAT'L AERO. SPACE ADMIN.		264	6	21	15	68	4	21	22	-	-	421
TRANSPORTATION		89	186	2	1	1	1	-	-	-	-	280
TREASURY		85	13	-	-	12	-	-	-	-	-	110
VETERANS ADMIN.		83	1	2	-	-	-	-	-	-	-	86
OTHER CIVIL		111	18	7	-	1	-	-	-	-	-	137
DEPT. OF DEFENSE		2,706	538	142	12	40	14	3	5	3,460	-	
(ARMY)		(771)	(76)	(17)	(4)	(-)	(5)	(1)	(4)	(878)	-	
(NAVY)		(868)	(102)	(51)	(8)	(4)	(3)	(2)	(-)	(1,038)	-	
(AIR FORCE)		(906)	(336)	(69)	(-)	(34)	(4)	(-)	(-)	(1,349)	-	
(OTHER DOD)		(161)	(24)	(5)	(-)	(2)	(2)	(-)	(1)	(195)	-	
TOTAL		4,714	845	201	39	132	28	26	29	6,014	-	

TABLE 9b. DESCRIPTION OF SINGLE AND MULTIPLE CPU COMPUTER SYSTEMS (Ref. 13).

THE TERM "COMPUTER SYSTEM", AS USED IN THE FOLLOWING TWO CHARTS, RECOGNIZES THE CHANGING COMPLEXITY OF THE TECHNOLOGY WHICH PERMITS THE INTERCONNECTING OF CPU'S AND RELATED COMPONENTS IN VARIOUS WAYS, AS REFLECTED IN THE FOLLOWING SYSTEM TYPE DESCRIPTIONS.

<u>TYPE</u>	<u>DESCRIPTION</u>
<b>SINGLE-CPU COMPUTER SYSTEMS</b>	
A	A COMPUTER SYSTEM CONTAINING ONE CPU AND NO REMOTE EQUIPMENT.
B	A COMPUTER SYSTEM CONTAINING ONE CPU AND REMOTE EQUIPMENT.
<b>MULTIPLE-CPU COMPUTER SYSTEMS</b>	
C	A COMPUTER SYSTEM CONTAINING MORE THAN ONE CPU IN WHICH ONE CPU IS THE MAIN PROCESSOR AND ONE OR MORE OTHER CPU'S (AND THEIR ASSOCIATED MACHINES) ARE USED FULL-TIME AS PERIPHERALS OR INPUT/OUTPUT (I/O) PROCESSORS.
D	A COMPUTER SYSTEM CONTAINING MORE THAN ONE CPU IN WHICH ONE CPU IS THE MAIN PROCESSOR AND ONE OR MORE OTHER CPU'S (AND THEIR ASSOCIATED MACHINES) ARE USED PART-TIME AS PERIPHERALS AND PART-TIME AS INDEPENDENT COMPUTER SYSTEMS.
E	A COMPUTER SYSTEM WITH MULTIPLE, CABLE-CONNECTED CPU'S SERVING AS INDEPENDENT PROCESSORS WITH SHARED MEMORY AND PERIPHERALS.
F	A COMPUTER SYSTEM WITH MULTIPLE, CABLE-CONNECTED CPU'S SERVING AS INDEPENDENT PROCESSORS AND OTHER REMOTE CPU'S (WITH THEIR ASSOCIATED MACHINES) SERVING FULL-TIME AS PERIPHERALS OR I/O PROCESSORS.
G	A COMPUTER SYSTEM WITH MULTIPLE, CABLE-CONNECTED CPU'S SERVING AS INDEPENDENT PROCESSORS WITH OTHER REMOTE CPU'S (WITH THEIR ASSOCIATED MACHINES) SERVING PART-TIME AS PERIPHERALS AND PART-TIME AS INDEPENDENT SYSTEMS.
H	TWO OR MORE COMPUTER SYSTEMS WITH ONE SYSTEM SERVING AS THE MAIN SYSTEM WITH THE OTHER ONE OR MORE SEPARATE SYSTEMS SERVING AS INPUT/OUTPUT PROCESSORS AND ALL UNDER THE DIRECTION OF A SINGLE OPERATIONAL MANAGER.
I	TWO OR MORE COMPUTER SYSTEMS PHYSICALLY SEPARATE BUT FUNCTIONING AS AN ENTITY UNDER A SINGLE OPERATIONAL MANAGER WITH UNIFIED INPUT, JOB FLOW, DISPATCH AND CONTROL.

telephone lines with these "Stand-Alone" facilities. This trend is characterized by (and consistent with the ADP procurement process discussed in Section IV-A) the acquisition by each individual site\* of (1) communications "front-end" processors compatible with the existing facilities and operations context, and (2) the purchase or lease of remote terminals compatible with the "front-end" and either leased or dial-up telephone circuits.

DCA, in a recent study (Ref. 1) for the AUTODIN II concept, made a comprehensive survey of existing DoD facilities in order to develop a traffic flow model for studying alternative design concepts and parameters. The data were collected with the fundamental objective that as large a number of candidate subscriber ADP facilities as possible be accommodated within an AUTODIN II design. Thus, the existing facilities were not examined for any systematic substructure. Such an effort would have been substantial and beyond the needs of developing an initial traffic model for the AUTODIN II objective. (However, the facilities were aggregated by geographical location, as would be required for a network topology.)

Table 10 is taken from Ref. 1 showing for each DoD element the projected 1978 distribution by CPU size and basing of computers with potential data communication needs which DoD elements identified as being candidates for common-user service. These facilities are principally Type II with the exception of the WWMCCS computers which are a mix of Type I and Type II and are shown for comparative purposes. These data show the dominant Air Force position in ADP systems.

---

\* Many stand-alone sites are administered by a command, military department or agency in aggregate form (e.g., Air Force Base Ops facilities). Thus, teleprocessing can be here viewed as individual purchase in bulk quantities.

TABLE 10. 1978 PROJECTION OF DoD MAJOR COMPUTER ASSETS  
BY DEPARTMENT AND SIZE (Ref. 1)

DOD ELEMENT AND LOCATION: CONUS/OVERSEAS

<u>NUMBER COMPUTERS*</u>	<u>WWMCCS(TYPE I)</u>	<u>DOD AGENCIES</u>	<u>AIR FORCE</u>	<u>NAVY/MARINES</u>	<u>ARMY</u>
Small 0-0.5 MB	7/2	0/0	463/78	311/19	169/64
Medium 0.5-3.0 MB	11/4	11/0	225/50	104/15	63/13
Large >3.0 MB	36/4	12/0	57/0	23/0	40/2
<u>TOTAL NO. COMPUTERS</u>	54/10	23/0	745/128	438/34	272/89
<u>NUMBER BASES**</u>					
Small 0-1.5 MB	12/6	6/0	95/38	23/11	105/15
Medium 1.5-3 MB	3/0	4/0	14/0	5/0	9/0
Large >3 MB	2/0	0/0	7/0	3/0	1/0
<u>TOTAL NO. BASES</u>	17/6	10/0	116/38	31/11	115/15

\*Computer size is categorized by size in megabits (8 bits = 1 byte) of CPU core memory.

\*\*Base size is categorized by adding core memory of all CPUs resident on base.

From GSA 1973 data, it is apparent that DoD accounts for approximately 70 percent of the computer assets in the Federal Government. Of the DoD computers, the Air Force/Navy/Army split 39/30/26 percent with 5 percent going to DoD agencies. From DCA 1978 projections of computers with potential for data communication needs, the Air Force/Navy/Army split is 48/26/20 percent plus 4 percent for WWMCCS and 2 percent for DoD agencies. However, in terms of the number of sites with computers, the Army approximately equals the Air Force with an Air Force/Navy/Army split of 44/12/36 percent and 6 percent for WWMCCS and 2 percent for DoD agencies.

Comparison of GSA 1973 data (Ref. 13) and DCA 1978 projections (Ref. 1) would indicate that within DoD, the Air Force has the most rapidly developing need for teleprocessing activities. Further comparison shows that the Navy is the second most rapidly advancing potential user of computer teleprocessing but has, by a wide margin, the fewest geographically distributed sites. The Army, which appears to have the more conservative approach to teleprocessing, has almost as wide a geographic distribution in basing as the Air Force.

From these data one could expect the earliest need for data network support with significant geographic coverage to teleprocessing to develop within Air Force related ADP activities. Army network needs, perhaps latest in time urgency, can require a network geographic distribution as extensive as the Air Force. The Navy network needs probably can be more concentrated into fewer long-haul trunks.

## 2. Functional System Inventories

Within the Headquarters element of each of the military Services and agencies of DoD, there is an ADP-related section for monitoring and overseeing ADP activities of the respective Service or agency. These offices help collect and maintain the DoD and GSA ADP data base described in the previous section. In addition, listings are made of ADP functional systems. A typical functional system is composed of standardized applications program software run on principally stand-alone standardized computers distributed throughout an organization (e.g., materiel command) plus the collection of periodic data inputs and the generation and distribution of reports. An example of such a listing is shown in Table 11 provided by the Management Information Systems Office of the Army Chief of Staff. Here is shown in synoptic form the functional system, SPEEDEX, its function, applications programs, and the type and location of the ADP facilities. Also indicated is the presence of some remote terminals in the system.

The various responsible DoD offices maintain similar listings of functional systems in a format most convenient to their needs. There is as yet no DoD-wide standard way of listing the functional



systems. A preliminary listing was reported in Ref. 15. Scheduled for publication in November 1974 is a listing of ADP systems in use by the DoD. This is a major effort undertaken by the DoD Logistic Systems Policy Committee, ASD(I&L), LSPC Task 3-70 (Ref. 12). This inventory, however, will not directly assess the teleprocessing features of the identified DoD systems. As part of the DoD Internet Study tasked by DTACCS (Ref. 5, Appendix F) a listing of operating and proposed DoD ADP systems and their characteristics has been prepared and is currently maintained by the DCA at its Engineering Support Center, Reston, Virginia.

### 3. Communications

To the best knowledge of the authors of this report and with the exception of AUTODIN I\*, no aggregated communications utilization data for circuits and terminals specifically associated with supporting current teleprocessing activities within DoD are available. Communication data do exist as a component of each specific system description. Consequently, such data are in considerably fragmented form. The communications elements are being studied and analyzed as a part of teleprocessing systems studies. Reference 5 contains the most current estimates of current need and projected flow.

#### C. TELEPROCESSING SYSTEMS

The systems-related requirements activities can be categorized as follows:

1. Teleprocessing upgrade to existing ADP facilities (Ref. 16)
2. New teleprocessing systems including new ADP facilities (Ref. 2)
3. Common-user network (Refs. 5, 9)

---

\* AUTODIN I speed of service or mode of operation is generally considered to be inadequate for the technical requirements of future interactive or transactional teleprocessing systems. Furthermore, additional heavy growth in computer-associated communications can place too heavy a traffic burden on AUTODIN I capacity.

Almost all presently operating systems are in category 1, that is to say, stand-alone ADP sites which have added remote terminals to upgrade with some teleprocessing capabilities. Systems of category 1 add terminals at known sites\* with a need to communicate with an existing specified ADP facility. The requirements for such specific systems tend to be well delineated as to terminal configurations, line speeds, traffic volume, response time, etc. The requirements usually lead to specific technical specifications of terminals, modems, transmission lines, and ADP site modifications. This is illustrated in Fig. 18 taken from the proposed interim MAC Information Management System (MACIMS) (Ref. 16).

An example of category 2 is the Computer Network concept of the SADPR-85 study discussed in Section III. Here requirements generation becomes more complex. Both ADP sites, as well as terminal locations and sizings, must be made in addition to choosing a communications topology and capacity. Based on current and projected ADP-related tasks, a model is generated relating computer loading with terminal transaction activity to component system performance factors. From this computer and terminal capacity is projected, and traffic flow requirements\*\* between computers and terminals are estimated. This, then, becomes an input to a communications network design to layout line connectivity and capacity.

An example of category 3 is the DCA AUTODIN II concept (Ref. 1) discussed in Section III. There the principal requirements focus on traffic flow necessary to design and size a common-user switched data communications network. The communications traffic flow was modeled independently of specific ADP tasks. Data were collected on computer size and location as well as projected terminal types and

---

\* Within the command or mission responsibility of the parent ADP facility.

\*\* A complex quantity including a geographic matrix, daily flow, peak hour flow, response time (interactive), tolerable error rate, etc.

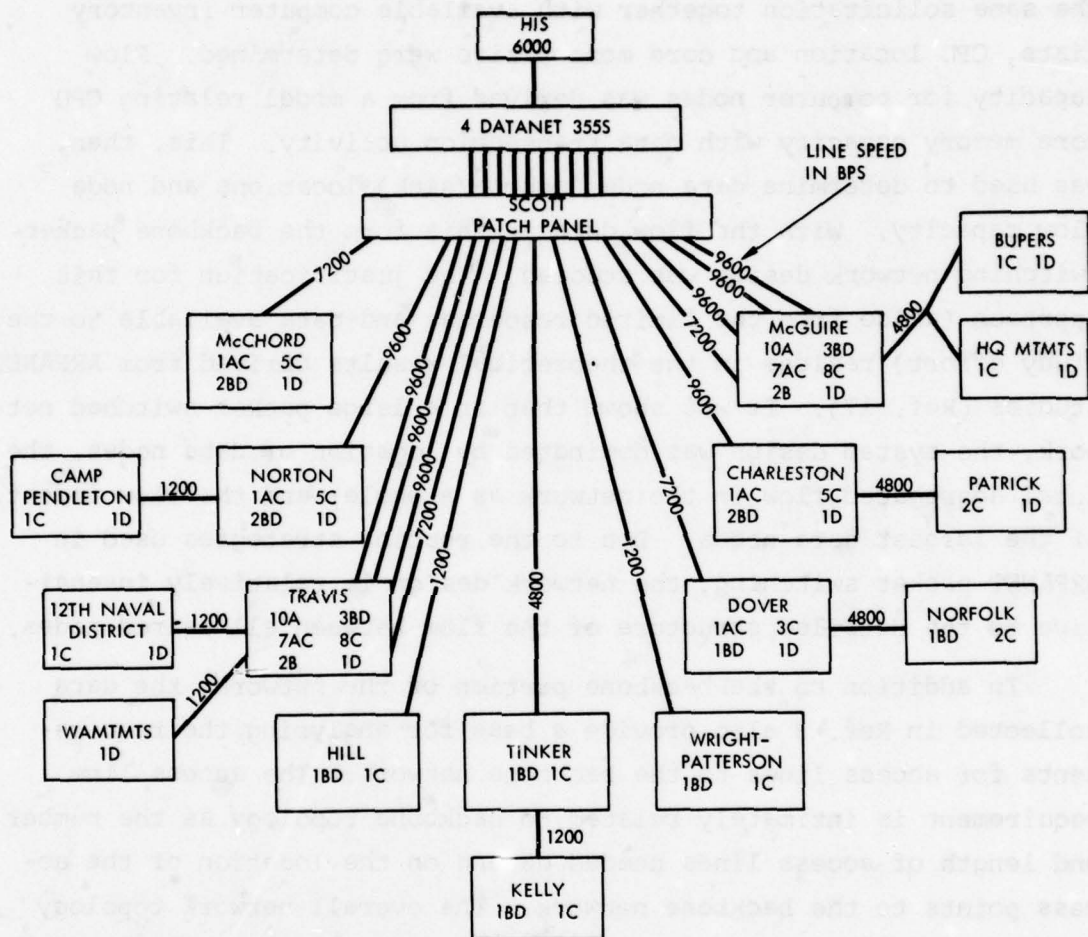

TERMINAL EQUIPMENT KEY:

- A - Cathode-ray tube display (CRT) with keyboard
- AC - Cathode-ray tube display with keyboard and hard copy
- B - Medium speed printer
- BD - Card reader/card punch/medium speed printer
- C - Teletype inquiry device
- D - Card reader/card punch

2-12-75-13

FIGURE 18. Proposed Long-Haul Communications with Multiplexers for MACIMS (Ref. 16)

locations. Terminal node flow capacity was derived from questionnaires submitted to various DoD elements which solicited number, location, type of terminals, and type of service envisioned. With the same solicitation together with available computer inventory lists, CPU location and core memory size were determined. Flow capacity for computer nodes was derived from a model relating CPU core memory capacity with data transaction activity. This, then, was used to determine data node (source/sink) locations and node flow capacity. With the flow data in this form the backbone packet-switching network design was studied. The justification for this approach (aside from the limited resources and data available to the study effort) resides in the theoretical results derived from ARPANET studies (Ref. 17). It was shown that in a large packet-switched network, the system design was dominated by location of data nodes, the total aggregated flow in the network as a whole, and the flow in/out of the largest data nodes. Due to the routing strategies used in ARPANET packet switching, the network design is relatively insensitive to the detailed structure of the flow between all paired nodes.

In addition to the backbone portion of the network, the data collected in Ref. 9 also provide a base for analyzing the requirements for access lines to the backbone network. The access line requirement is intimately related to backbone topology as the number and length of access lines needed depend on the location of the access points to the backbone network. The overall network topology and associated component capacity requirements (lines and switches) form a delicate interplay between the backbone and access line portions. Sophisticated graph theoretic techniques must be utilized with computer-aided design using an interactive set of algorithms\* to seek an optimum overall network design.

---

\* This process has been referred to as heuristic programming.

As part of the DTACCS Internet Study\* (Ref. 5) a reexamination of the DoD candidate teleprocessing systems has been conducted and will continue. One of the objectives is to refine the technical requirements of the more immediate candidate subscribers to a common-user switched data network. Additional data are also provided as to the other proposed teleprocessing systems and their time frame. This provides for the first time in DoD a common frame of reference for preparing teleprocessing system descriptions and requirements. Without such a requirements overview, it is very difficult to assess the present status and projected teleprocessing needs or to make judgments as to priority of need.

#### D. SUMMARY

In this section a review of the type of data available within DoD as to ADP assets and systems and the relationship to formulating teleprocessing requirements was presented. The principal ADP utilization data collected to date in aggregated form relate to inventory lists of computer hardware and location for primarily stand-alone facilities.

The present teleprocessing requirements formulation is done on a system-by-system basis, a reasonable process compatible with upgrading present systems but inadequate for any overview of aggregated teleprocessing requirements. The studies in Refs. 1, 2, and 3 exhibit by example some of the factors required in developing and aggregating teleprocessing requirements.

Functional ADP systems data have been collected and aggregated by two studies sponsored by OASD(I&L) (Refs. 18 and 19). Reference 5

---

\* Reference 5 only became available in draft form during the final preparation phase of this study. Consequently, no time was available to digest the results and incorporate them here. The interested reader is strongly urged to examine Ref. 5.

provides development of Functional System Data in a form relevant for formulating teleprocessing requirements. These data have been collected as an interim ad hoc committee activity. There currently is no one element within DoD or more specifically OSD charged with developing and maintaining a current and more comprehensive ADP utilization data base, especially to include teleprocessing-related data. Teleprocessing-oriented requirements data are needed in order to address the following issues:

- System architecture (centralized versus decentralized processing)
- Individual ADP site configuration
- Communications-induced ADP tasks
- ADP-induced communications capacity and transmission configuration.

It is very important to establish within DoD a requirements formulation function to provide a comprehensive view of ADP needs including data communications.

Computer inventory listings and their base site distribution indicate that the earliest needs for Type II teleprocessing with the most geographically extensive communications requirements will most likely develop within the Air Force. The Navy data communications needs to support Type II teleprocessing, although next most rapidly developing, should be more geographically concentrated. The Army, with perhaps the most conservative approach, nonetheless will eventually need data communications as geographically extensive as those of the Air Force.

## V. DESIGN AND ARCHITECTURAL CONSIDERATIONS

Architecture and design considerations for teleprocessing systems are characterized by dimensional complexity and analytical difficulty. In addition to the technological design problems, there is the cost sensitivity to complex schedules of transmission tariffs and equipment charges. In projecting future availability of equipment and cost trends, one must be aware of the intangible business interests of the suppliers of equipment and services with regard to competitive market factors, continuity of product lines, and customer capture. The object of this section is to summarize the elements of design and analytical methods currently in use. This then provides an opportunity to discuss areas of insufficient technical understanding and gaps in methodology.

Present design methods have evolved in the context of cost-effective utilization of the current telephony plant to support centralized third-generation computer centers. Design techniques have focused on providing dedicated teleprocessing systems utilizing communications as a component subsystem of the overall ADP system. Such systems have been principally utilized by corporate ADP activities on the one hand and commercial service bureau or time-sharing systems on the other. In the latter case, a data network is employed to reduce long-distance toll charges to the general public subscribers. The network portion of the overall teleprocessing system is designed and operated in support of a vertically integrated ADP system. The interface with the subscriber is at the nearest node or point of access to the network. The network is effectively an extension of the computer center(s).

With the advent of the ARPANET\*, design methodologies have begun to evolve wherein common-user data communication factors are addressed in their own right. These methodologies, however, initially tended to be rather tightly coupled to the ARPANET specific concepts of operation (standard interface and network protocol, distributed topology, adaptive routing, and specific division of network responsibilities, vis-à-vis subscriber, e.g., error control). Only recently has the development of these design techniques been broadening into more general tools.

## A. DESIGN TOPOLOGY AND ANALYSIS

### 1. Topological Types

There are two very different classes of network topologies (i.e., the arrangement of nodal points and their line interconnections). One is the Star topology as shown in Fig. 19 representing the proposed initial phase of the MACIMS network (Ref. 16). A generalization of the Star is the Tree topology which is shown in Fig. 20a. Figure 20b shows a loop variation of the Star. A key feature of the Star or Tree topology is the focus on a centralized computational center whose communications fan out to its remote users.

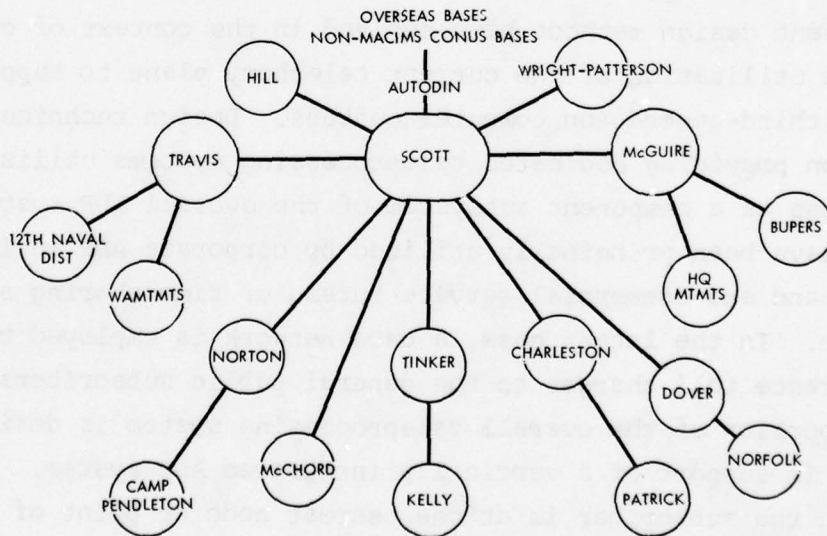
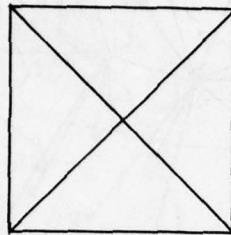

FIGURE 19. Proposed Initial MACIMS Network (Ref. 16)

\* It is worth noting here that the first operational and largest operating network using packet data transmission is SITA (Ref. 20), supporting a common European airline reservation system.

The other type of topology is the distributed network for which an idealized type is the  $n$ -node  $m$ -connected graph shown below, wherein there are  $m$  connections between each of  $n$  nodes.



$n=4, m=3$

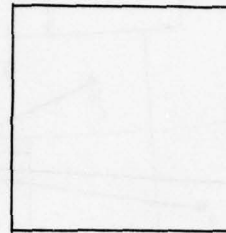

$n=4, m=2$

The idealized type of network connections in distributed systems are of little direct practical interest. Most distributed networks are more complex variations. The best known example of a distributed network is the ARPANET whose evolution through time (up to 1972) is shown in Fig. 21. The distributed network usually provides greater communications path redundancy [hence enhanced reliability (Ref. 21)], but does not economically support a centralized teleprocessing system.

Several operating teleprocessing systems to date have evolved hierarchical mixes of centralized Star (Tree) subnetworks interconnected with a distributed backbone network. Examples of these are shown in Figs. 22, 23, and 24 representing the network topologies of CYBERNET, TYMNET, and INFONET, respectively. Here each Star subnet evolved in support of its centralized (regional) ADP center. However, the regional ADP centers are interconnected in a distributed fashion to provide reliable backup together with load and resource sharing between centers.

The type of network topology and hierarchical architecture utilized in the design is quite important. Analytical and design optimization techniques depend on the class of topology postulated. Broad

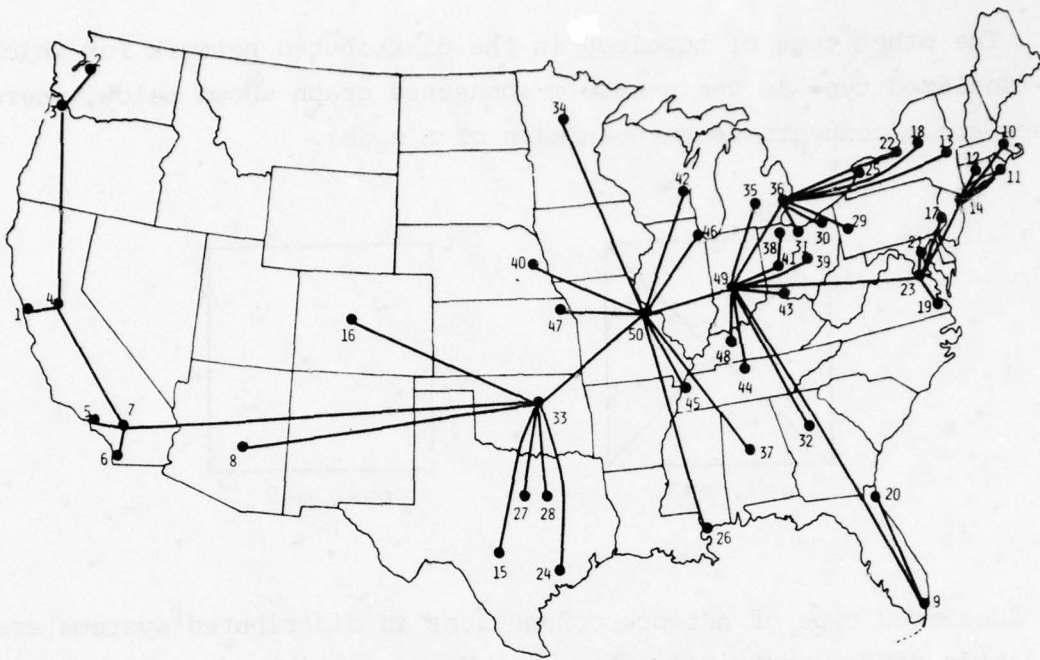

FIGURE 20a. Single Connectivity Tree Network (Ref. 3)

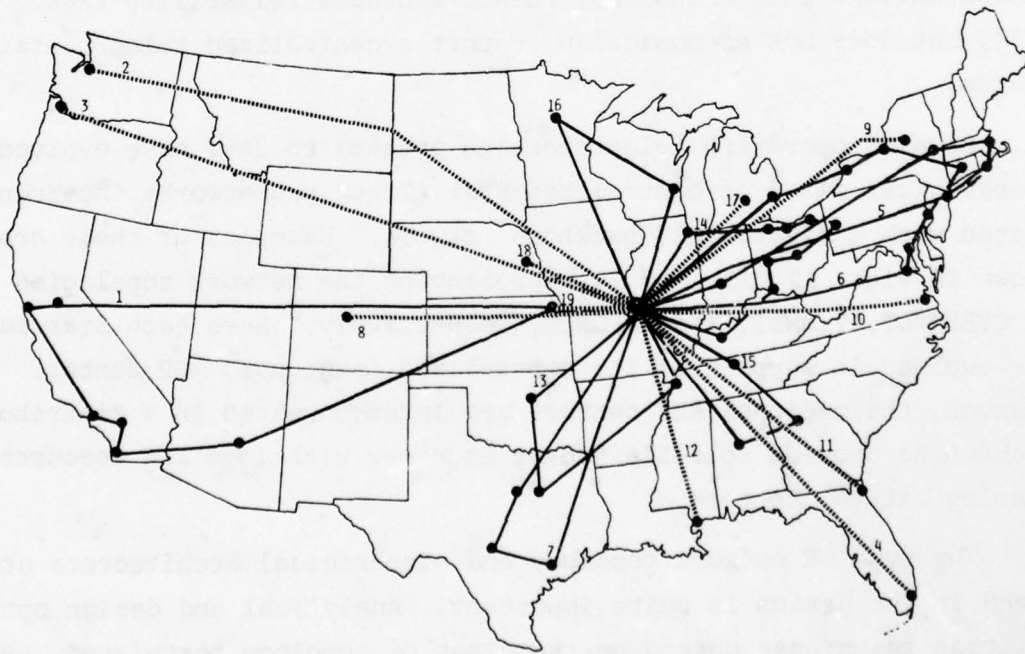
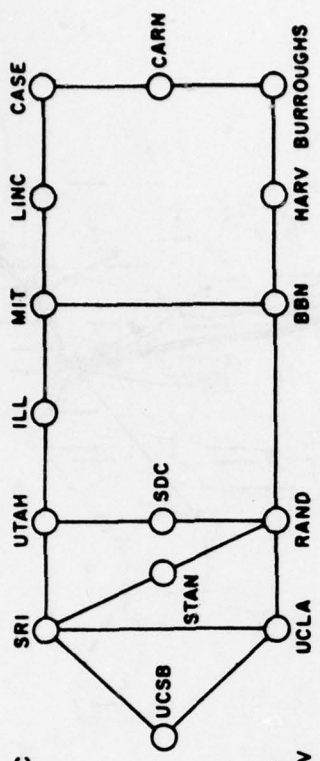
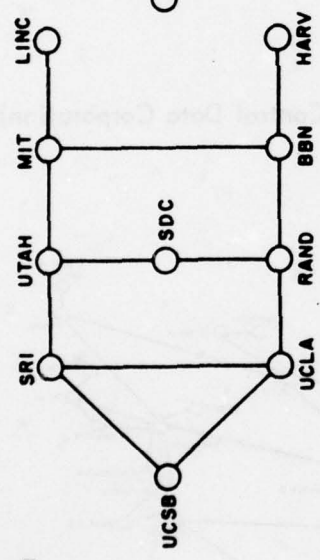

FIGURE 20b. Single Connectivity Ring Network (Ref. 3)



(a) 15 IMP Network  
12/1/69



(b) 10 NODE Network  
7/1/70

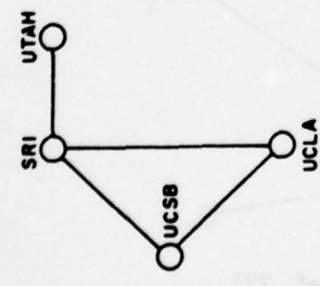

(c) 15 IMP Network  
3/1/71

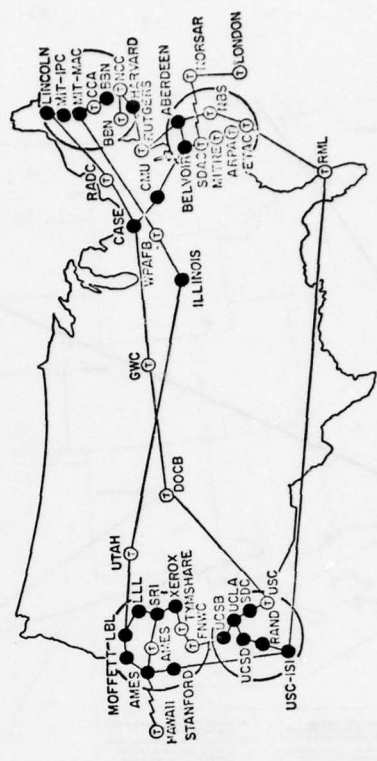

(e) ARPA Network 1/1/74

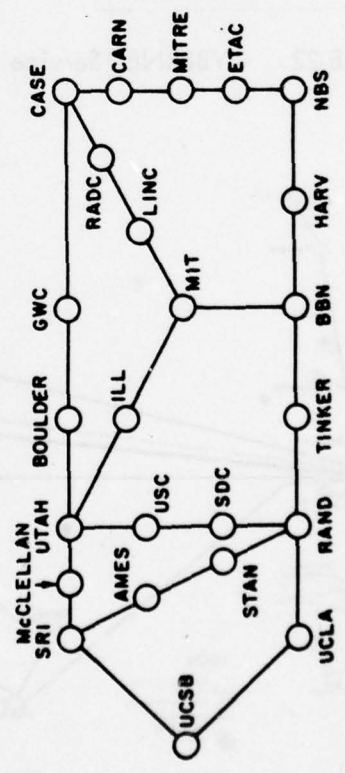

(d) 24 IMP Network  
4/1/72

FIGURE 21. The Evolution of the ARPANET (Ref. 22)

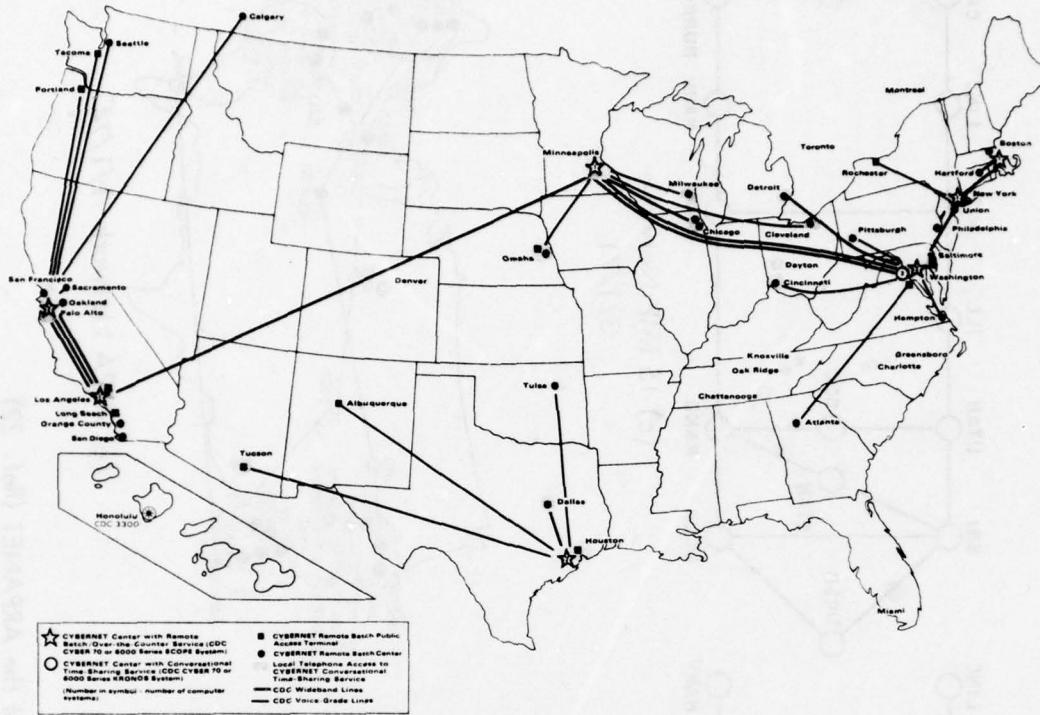

FIGURE 22. CYBERNET Service (Courtesy of Control Data Corporation)

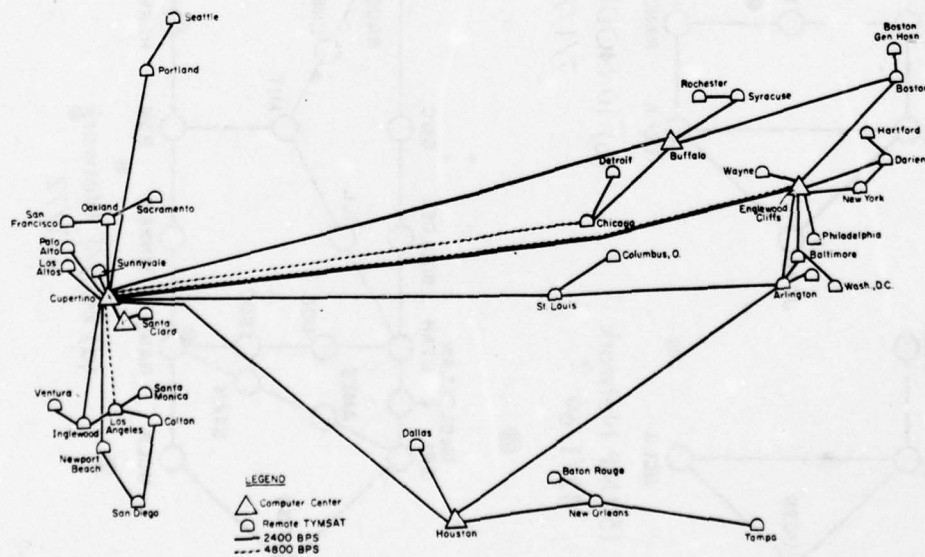

FIGURE 23. TYMNET Map (Ref. 23)

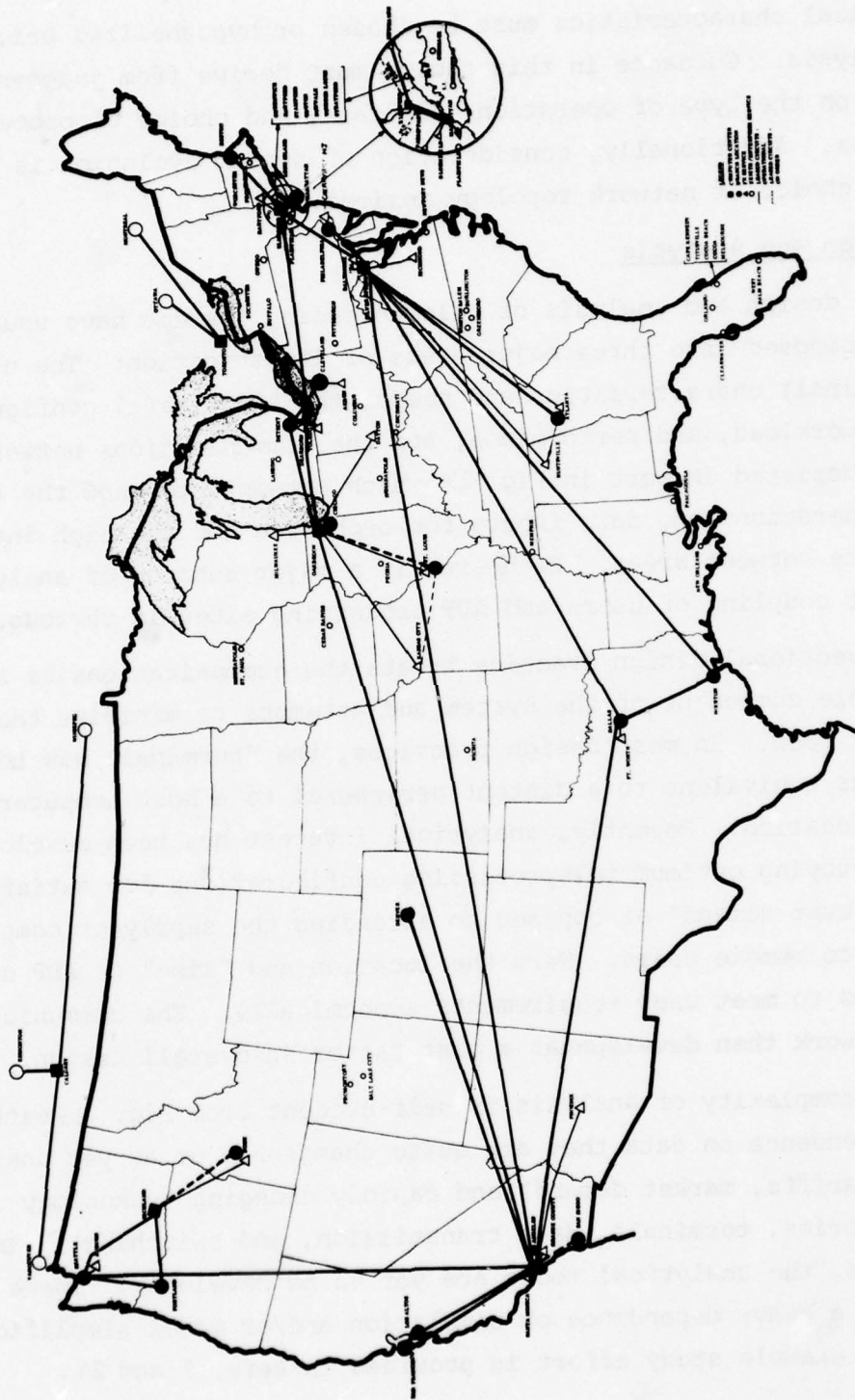

FIGURE 24. INFONET Communications Networks (Ref. 23)

topological characteristics must be chosen or hypothesized prior to the analysis. Guidance in this choice must derive from judgment depending on the type of operation, ADP task, and choice of processor locations. Additionally, consideration of system evolution is important in choice of network topology desired.

## 2. Design and Analysis

The design and analysis of teleprocessing systems have usually been decomposed into three major areas of investigation: The user (or terminal) characteristics and needs; the ADP site(s) configuration, workload, and performance; and the communications network. This is depicted in part in Fig. 25 which attempts to show the types of considerations and data inputs for each area and the high interdependence between areas. Each area is a major subarea of analysis. The tight coupling of users and ADP processing sites is obvious.

Conventional design practice treats the communications as a purchasable component of the system and attempts to minimize the component cost. In most design practices, the "terminal" has been treated as equivalent to a distant peripheral to a host computer at a given location. Recently, analytical interest has been developing in studying optimum teleprocessing configurations for satisfying the "user demand" as opposed to extending the supply of computer services to remote users. Here the location and "size" of ADP sites are varied to meet user requirements economically. The communications network then develops as a cost factor in overall design.

The complexity of analysis is self-evident from Fig. 25 with heavy dependence on data that are quite changeable or as yet unknown (costs, tariffs, market demand) and rapidly changing technology (CPU, memories, terminals, data transmission, and switching). In many cases, the analytical tools are yet to be developed. There is generally a heavy dependence on simulation and/or model simplification. An example study effort is provided in Refs. 3 and 24.



initial theoretical network layout of nodal locations,\* line routes and their respective capacities (nodal throughput and line speed or bandwidth) provide cost estimates that can be interacted with the computer/terminal design which results in reevaluating initial assumptions and guidelines and then reiterating the design process.

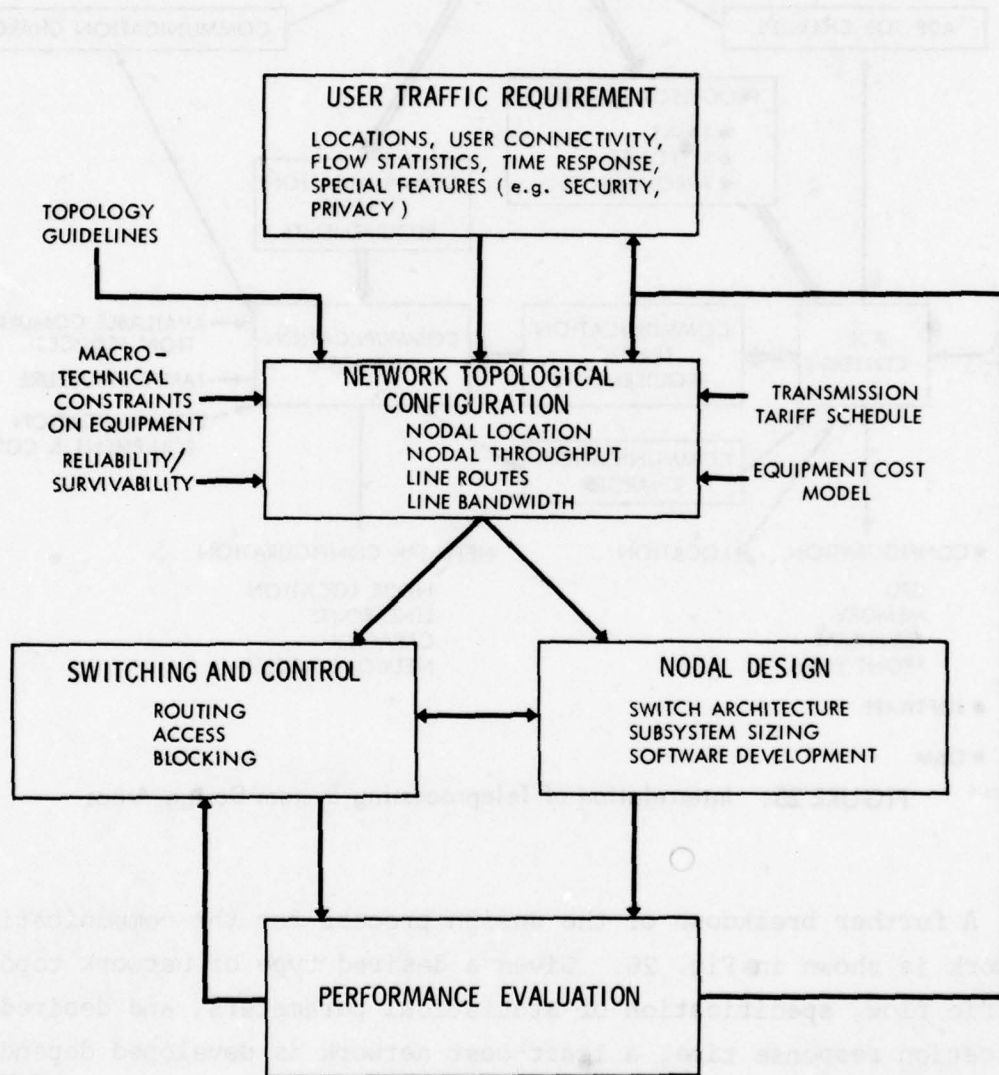

11-22-74-1

FIGURE 26. Teleprocessing Communication Network Design Process

\* ADP sites, access points, concentration and/or switch points.

With an initial network concept, topology, and estimated capacity requirements, detailed analysis is then directed at equipment design and development, especially at network nodes to provide the necessary network functions. The logic design and sizing of nodal processors and memories for concentrators, switches, and front ends together with developing routing algorithms, access standards, network control, and associated system software (Ref. 26) are some of the major nodal design problems. Here, again, reiteration with the network topology and sizing is required. In addition to cost impact, specific design developments in network nodal and access features also have strong interaction with the ADP site and terminal equipment and usage (Refs. 26, 27, 28).

The familiar problem of ADP site configuration and management analysis is conceptually analogous to the problem in designing the communications network. Here the architecture, sizing, allocation, and control of site assets (CPUs, memories, I/O devices, etc.) are of concern. This problem area, predating that of the communications network, certainly has received the preponderance of effort in the past and has a more developed methodology than network design. Even so, the analytical tools do not appear to be in a sufficient state of advancement to adequately answer many questions of practical importance, e.g., predicted versus realized performance. Inadequate design methods usually result in the acquisition of oversized or underutilized components to achieve a margin of safety. However, unexpected processing choke points often develop. The latter cause the more significant economic loss. It appears that the design inadequacies are due to an inability to predict accurately the performance of the interdependent hardware/software system.

The design methodologies used for both ADP site configuration and communication networking are based upon the mathematical tools of queueing theory and flow graph theory, as well as relying heavily on computer simulation techniques. However, the respective problem constraints and design objectives desired between site configuration and networking are sufficiently different to have caused development of

differing specializations of the analytical methods. For example, communication constraints on data speed and delay are of less concern in analyzing ADP site configuration. On the other hand, storing and manipulating large arrays of data or interleaving a multiplicity of processing tasks have been of lesser concern to the data communications design.

There is developing a strong need to bring together these two areas of theoretical endeavor. This follows from the coupling between (a) network design and load and (b) ADP site configuration and tasking. Furthermore, implementing communication network nodal functions, such as access control, switching or message routing, concentrating, etc., will depend on utilizing ADP technology, i.e., the node is itself an ADP site in miniature with specific processing tasks. Additionally, nodal activities may in part be collocated with a processing site and be included within the site configuration planning.

In addition to the problems in the design of teleprocessing systems, there are many problems of great practical interest and theoretical challenge in how a teleprocessing system is used. One of the main motivations for developing the ARPANET was to address such problems. Illustrative objectives include:

- Manipulating geographically distributed data bases
- Utilization or sharing of ADP assets (hardware and/or software) between sites
- Distributed processing.

These have led, for example, to studies in computer language translation, data structures and architecture, interprocess protocols, systems control, and privacy.

Interesting problems exist in cost optimization of an existing teleprocessing system. For example, in Ref. 29, the problem is addressed of least-cost assignment of residence of a user's programs at different sites where program length and utilization factors together with storage and transmission costs are given. This leads to

a linear integer programming solution whose dimensions grow exponentially fast with the number of programs and choice of available resident sites.

## B. SYSTEM SHARING

### 1. Sharing Elements

The previous section outlined the analytical features used in designing a teleprocessing system without addressing issues associated with intersystem operation or sharing. The objective here is to focus on some of the factors introduced by sharing. Design factors in the sharing of system communication assets take on special significance in regard to the major issues that relate to the organization, implementation, and use of common-user switched data networks as opposed to providing dedicated communication support to teleprocessing systems. Technical issues that relate to sharing arise within as well as between systems. Any computer site with ADP "time-sharing" capabilities is shared as a dedicated communication network is shared by the remote terminals accessing the computer. It is not always clear as to where problems of intrasystem sharing leave off and intersystem sharing begins. Much depends on the specification of system boundaries and responsibilities. The issues of separation and assignment of system responsibility are themselves a problem area.

There are three subsystem components in teleprocessing that can be shared:

1. Terminals
2. Communication facilities by different computer systems and associated terminals
3. Computer facilities: hardware, programs, data bases.

The sharing of computer facilities, hardware, software, and data bases is a major activity in computer science. Sharing of ADP resources represents the most significant potential for obtaining the greatest reduction in overall ADP costs through appropriate aggregation of ADP tasks, organization of function, and location of computer facilities relative to as broad a shared user base as can be satisfactorily achieved.

In what follows, discussion is focused on sharing communications for interconnecting computers and terminals. Whatever potential economies can be achieved through the aggregation and/or sharing of ADP functions, such economies cannot be realized without a communications network. The economies that can be realized through sharing communication facilities, though significant, should not be allowed to inhibit realizing the savings achievable in computer (including O&M) costs. Discussion here is directed principally to sharing the communications network components because the issues appear to be more developed.

Many have assumed implicitly that a subscriber-oriented, common-user, switched data communications network represents an ultimate in shared communications. This follows naturally from the example set by and economies realized from the common-user telephony plant. For data communications, it remains to be demonstrated that such an "ultimate" will prove both technically adequate and economically attractive. Human subscribers of the common-user telephony plant employ standard equipment (handset, auditory and vocal apparatus) together with a standard mix of protocols and adaptive capabilities (language, cultural context, inquiry/analysis) not yet achieved with data processing systems.

## 2. Sharing and Switching

In discussing the design issues for sharing communication facilities, it is useful to stipulate which communication components are being shared, and their structural relationships. It is possible to share facilities at different levels with different communication functions. In CONUS, almost all\* dedicated teleprocessing systems "share" the transmission facilities of the Common Carriers (principally the Bell System). Presumably, even if DoD teleprocessing systems were to develop in a proliferated manner, they would still share the DCS transmission facilities. Consequently, the structure of the shared communication elements will have large bearing on required circuit routes and

---

\*Including commercial and corporate systems.

capacity, nodal locations, and switching. Of even greater ultimate importance is sharing ADP functions and terminal capabilities.

Within communications assets, the following elements can be shared in a number of arrangements:

- Local access--loops or distribution lines
- Multiplexers, concentrators
- Long-haul transmission.

The span of sharing across these elements together with desired degree of site interconnectivity then lead to requirements for the fourth element:

- Switches.

For example, it is possible to conceive of a shared communication system in which there is no switching within the communications network. Subscriber sites specify in advance all other sites to whom they wish to connect within their own system(s). Any switching is done at the subscriber's site and "new" messages reintroduced to the communications plant. Such a system can be implemented with dedicated trunks and multiplexers which are (re)connected at the subscriber's order. Further, certain "simple" type circuit switches could be implemented to facilitate network control, circuit restoration, and quicker response to new subscriber connectivity orders. This system description is obviously that of the present Common Carrier facilities as it provides shared service to dedicated teleprocessing systems.

The introduction of concentrators that provide dynamic time sharing of the long-haul trunks realizes the principal potential for cost reduction in long-haul data transmission costs over fixed routes. In this context, the term switching is somewhat ambiguous. The narrow meaning refers to the ability of any system subscriber to call any other subscriber on demand. However, in a broader sense, there is switching involved in the long-haul concentrators. The implied concept is to prestore in the concentrators all of the preordered paired subscriber connections allowed. In this fashion, the paired users

could dynamically use the trunks as needed, but on-call connections could not be made. Concentrators operating in this mode achieve the economic advantages in number of trunk lines needed as well as the dynamic sharing of trunk capacity. [In fact, switches were introduced in the telephony plant for the purpose of "concentrating" subscribers' use of circuits. It was taken as a matter of course that any subscriber (human) should be able to connect to any other subscriber (human). For current teleprocessing system, this assumption may not be valid.] Thus, if cost reductions for long-haul communications are achieved through either lower tariff rates and/or dynamic time sharing of the line capacity, the principal advantages to sharing long-haul transmission facilities will have been achieved. The need to share communication access lines, terminals, and, to a lesser degree, on-call interconnection of ADP systems would appear to be the principal factors for developing dynamic network switching.

Communication facilities can be shared in at least the following ways:

- a. Bilateral (or multilateral) agreements between parties with congruent transmission routes
- b. Aggregates of users agreeing to pool communications with minimal switching capability as in the example quoted above
- c. Common-user switched system
- d. A mixture of the above.

Small systems will be motivated toward sharing communication facilities, especially costly long-haul circuits. Large systems, for which communications are a smaller percentage of cost and who must emphasize the integrity and control of their own system, will be motivated to acquire "dedicated" communication, i.e., one whose utilization and control of capacity is under their control. This provides an important variation on (d) above, namely

- e. Piggyback communications service provided by a "large" system to a smaller system.

The level and arrangement of desired sharing of transmission facilities and degree of connectivity required have heavy impact on the kind and architecture of switching desired, the location of the switches, their capacity, and the network control implemented. The way in which the network design process proceeds is discussed in Section V-A. As shown in Figs. 24 and 25, the sharing strategy serves to define the major blocks of ADP users and ADP centers.

The design of a common-user (switched) approach will initially tend to separate the network design from the more specific ADP-related factors. In order to make the common-user system as attractive to as many subscribers as possible, only the general data flow characteristics of generic users and their locations can be considered initially. The ADP sites are differentiated from terminal sites principally in their high volume of data flow and geographic location.

In this approach the ADP subscribers must make individual adjustments to bring their sites on-line to the common-user network. As ADP subscribers join the network, undesirable network features would be deleted, new features added as needed, and network refinement made as experience and subscriber confidence are gained. Network architecture and topological guidelines that must be stipulated for initial network layout have included network management and control considerations as well as expected traffic flow models derived from user locations and flow densities. Factors relating to ADP subscriber issues have not yet been able to be included in initial network planning. Consequently, there is the potential that network switching and interface decisions can be made which are not fully cognizant of the potential ADP subscriber problems.

It is assumed that as the common-user system evolves, the many detailed problems relating to data standards, interfaces, access, network control, impact on ADP site operations, etc., will be solved or satisfactorily ameliorated. Behind this assumption is the belief that the attractive features of a common-user network will cause computer technology and data network development to draw together

sufficiently to justify the assumption. Unfortunately, there does not appear at this time any concrete technical way of substantiating in advance the viability of the common-user network. At this juncture, only additional development activity in common-user network technology to specifically define the major problems and provide an environment to experimentally pursue their solution could indicate the future viability of a common-user data network.

Several alternate opportunities for network testbeds avail themselves such as:

- Utilize one or several commercial nets such as proposed by the VANS
- Conduct experiments with one or more DoD networks such as ARPANET, PWIN, and SATIN IV
- Initiate a new testbed network.

Another alternative would be to delay immediate network test activity, while pursuing further analytical refinement and collection of DoD teleprocessing requirements on the one hand while awaiting new data transmission service offerings by the Common Carriers (see Section VI-A).

### C. NETWORK DESIGN PROBLEMS

In this section, a short survey is provided of some of the design and analysis efforts that have been reported in the open literature. These were taken to be illustrative of some of the types of problems addressed and to provide by example a feel for what types of problems have been of concern and received some analysis. The papers selected\* here were chosen from those known to the authors according to the criteria that they illustrate some problem of significance and provide a point of departure for those readers with technical interest to pursue the subject. They all address some feature of a teleprocessing network design problem. None addresses the problems relating to ADP use of the network, data standards, protocols, and the like. Much of

---

\* Many of these enjoy the convenient property of being located in the same publication.

the work reported was prompted by the activities of ARPANET and/or a Common Carrier.

## 1. Overview and ARPANET

An overview of a selected set of teleprocessing systems is provided in Ref. 30. A useful and very extensive bibliography on computer networks is kept current at the National Bureau of Standards (Ref. 31). Sampling of various analytical skills employed in teleprocessing network design is provided with selective problem areas discussed in the book by Abramson and Kuo (Ref. 32). Treatment in greater depth of dedicated centralized system design is given in the books (Refs. 33, 34) by James Martin. A description of four large networks' operations is given in Ref. 23. A sophisticated model and analysis of the communications for a class of centralized teleprocessing systems are presented in Ref. 35. Formulas are developed to estimate system behavior (line and buffer capacity system throughput, data delay, buffer overflow probability, etc.). This includes both Star and Loop networks.

An overview of topological features of data network analysis is given by Frank and Chou (Ref. 25). An initial investigation of the flow properties of a store-and-forward message (e.g., packet) network was provided by Kleinrock (Ref. 36). The mathematical basis for techniques of network flow optimization is presented by Frank and Frisch (Ref. 37). A synopsis of the design effort leading to the ARPANET configuration is given in Ref. 37. A current assessment of remaining problems and proposed design refinements for the communication subnet of the ARPANET is contained in Ref. 5. Recent progress in analytical refinements of the ARPANET communications subnet is contained in Ref. 28. Reference 28 indicates the initiation of study toward developing a hierarchy of regional subnets in a very large packet network.

## 2. Flow Control

A significant problem in a packet network is the control of traffic flow, both overall total flow and its user components. (In a circuit-switched network this type of problem is less complex.) In

Ref. 38, the problem of congestion-induced nodal blockage\* in a packet network was examined. An investigation is made as to the stability of node blockage. That is to say, will an overloaded, hence blocked, node cause its neighbors to overload and, if so, will this in turn lead to large portions of network blockage (instability)? This is an interesting paper that shows unstable conditions can develop. Even in stable conditions, blocked nodes can occur in clumps. Unfortunately, there appears to have been no further study of this problem.

A paper by Price (Ref. 39) utilizes simulation to evaluate the control of network congestion by limiting the total number of in-transit data packets within the network. The technique used, isarithmic,\*\* was proposed by Davies (Ref. 40). Of principal concern was the interaction of flow control and adaptive routing.

Another example of a flow control problem is the balance between user components of the total flow. That is to say, how does one prevent a subset of users with peak demand from blocking out other on-line users of the network? Some insight to this problem is provided in the paper by Pennotti and Schwartz (Ref. 41) who investigate the delay effects on other network users when one subscriber overloads the network with his traffic over a fixed route. The increased delay or throughput reduction caused to the other network subscribers is examined with respect to two representative types of subscriber flow control. One type referred to as end-to-end control limits at network access points the allowed instantaneous in-transit message (packets) between any subscriber source-destination pair. (This is similar to control used in ARPANET.) The second type, known as local control, limits the allowed peak number of subscriber paired source-destination packets at each of the nodes within the network (as opposed to the subscriber network access point). Results of this investigation

---

\* A condition whereby the node cannot accept more incoming messages, e.g., buffer overflow.

\*\* A method for keeping a constant number of packets in the network by creating and destroying "empty packets" to fill in unused network capacity.

for simple networks show no significant preference between the examined control strategies but the results dramatically demonstrate the need for controlling peak demand from individual users. With no control, peak demand from a user can effectively block out other users over major portions of the network.

The paper by Torbett and Harrison (Ref. 42) examines the congestion problem with regard to establishing user priorities on network nodal processing of packets. Packet prioritization is a method for achieving a form of user preempts analogous to those used in AUTOVON. The objective of the study was to study nodal scheduling strategies for handling prioritized packets. This effort utilizes esoteric mathematical (econometric) techniques to demonstrate the existence and characteristic of optimal control (node scheduling) over the prioritized packets. These suggest a different approach than is-arithmic control.

### 3. Reliability/Survivability

In a paper by Hansler et al. (Ref. 43) the communications reliability design factors for centralized teleprocessing systems are investigated and optimization techniques discussed. Wilkov (Ref. 44) utilizes the theory of probabilistic graphs to define and characterize various reliability measures for data networks. The author points out the serious lack of theory to account for network degradation resulting from failure in network elements due to traffic overload and encourages further effort in that direction.

A report to the Board of Governors of the Federal Reserve System (Ref. 45) examines the conceptual design and cost of an ARPANET type of network for the Electronic Funds Transfer System. By optimal addition of redundant communication links at given levels of increased system cost, the expected loss of service is obtained as a function of the probability of any one link failure. For very marginal increase in transmission costs, very dramatic (exponential) improvement is predicted. For a 2 percent increase in transmission costs, the same level of system outage could be obtained at a doubling of link failure. A summary of these results is presented in Ref. 21.

Study of network survivability, which is of especial importance to Type Ia teleprocessing systems (Section III), utilizes many of the analytic tools used in studies of network reliability but with different objective functions. A paper by Frank (Ref. 46) provides an overview of this problem and discusses various measures of network survivability. Several examples of network survivability issues and their analysis are discussed. Suggested areas for further theoretical development include incorporation of time dependence (time sequence attack, survivability through time), correlated network effects, multi-commodity analysis for multiple command centers and the interaction of network survivability and operational procedures.

#### 4. Packet/Circuit Switching Comparisons

The comparative analysis of circuit versus packet switching is quite complex. A very illustrative example of the factors involved is provided by Clowes and Jayasuriya (Ref. 47). User population and type of service are postulated in order to generate a traffic flow model. Then four different network topologies utilizing packet and circuit switching are configured to minimize the number of (4 kbps) channel miles in the network. Variations in topology and packet length were included. For the traffic model used and the performance measure\* "channel miles," the results showed considerable reduction in required channel miles by using packet switching rather than circuit switching. However, the packet-switch nodal throughput requirement becomes very large. A hybrid switching network was also considered wherein interactive traffic was packet-switched and bulk traffic circuit-switched. This configuration reduced the channel miles used from that of the all-circuit switched network but still significantly exceeded those of the packet system. However, the switch nodal throughput requirements (and hence cost) were considerably reduced over the all-packet system. The authors conclude that the hybrid approach appears promising in that it provides greater

---

\*This measure directly relates to transmission charges for long-haul dedicated trunks. It does not, however, include the costs of the switches.

flexibility to accommodate wider variation in user data characteristics and traffic parameters.

The paper by Itoh and Kato (Ref. 48) also compares packet- and circuit-switched networks. Utilizing a set of interlocking models of traffic flow and network operation, together with hardware component costs, the authors estimate the overall data network costs (including switching costs) for packet- and circuit-switching network realizations. An important assumption is the use of an all-digital transmission system and time-division all-digital circuit switching. The paper develops sets of tradeoff curves between access line speed and user circuit holding time.\* On one side of the curve, circuit switching is preferred (faster line speed, longer holding time) while on the other packet switching is indicated (slower line speed, shorter holding time). As an example under the model and assumptions used, it is concluded that packet switching is preferable for an access line speed of 2.4 kbps, and any holding time less than 10 sec (i.e., data blocks shorter than 24 Kbytes or 3000 characters).

Although not a comparison of packet versus circuit switching, the paper by Verma and Rybcznski (Ref. 49) is of interest in that it addresses whether data users with different message lengths should be segregated or integrated on the same transmission line. The problem considered is whether to share or to separate service to two data sources having different average message lengths. The average transmission delay to each user is compared between using separate channels or sharing a common channel. The two users are assumed to both have geometrically distributed message lengths but to have different average length. The paper shows significant improvement in average delay by assigning separate channels to the two users provided the average length of the longer message is greater than ten times that of the shorter. When the ratio of average message lengths between the two users exceeds ten, the average delay in message delivery on the shared channel increases exponentially.

---

\*I.e., the time a user wishes to hold a line to transmit his data; this is equal to the number of data bits to be transmitted divided by line speed.

## 5. Access Performance

Several interesting papers address the problem of an ADP or terminal site interacting with a communications line. These papers are all characterized by their examining the data transfer performance between ADP users. They can be of use in analyzing the network access problem. The Star or Tree centralized configuration can be useful in structuring the local transmission of terminals to an access point of the backbone network.

In the paper by Spragins (Ref. 50), results are presented of a simulation of the overload characteristics of a com front end at the central computer site of a Star network. The author concludes that system load saturation of the com front end is extremely sharp. In a separate paper (Ref. 51), Spragins uses a simplified queueing model to analyze a computer I/O port connected to terminals on a loop or ring access line. Of principal interest here is the expected waiting time to deliver a message which then determines the terminal buffering requirements. In the paper by Hayes (Ref. 27), a combined approach of analytical and computer simulation is used to investigate the performance of a looped Star system using time-division demand access by terminals located on the loops which are all digital high-speed line (T-1, 1.5 Mbps). At the center of the loops is a control and switching computer which routes traffic between loops. Throughput, delay, and buffer overflow are studied as a function of number of terminals for several switching/control strategies.

## 6. Buffer Analysis

Techniques useful for analyzing buffer requirements for communications devices (terminals, front ends, contrators, packet switches, etc.) are illustrated in papers by Chang (Ref. 52) and Chu (Ref. 53). Several buffer management strategies are examined. Results of this type are of considerable utility considering the large distributed use of buffers in teleprocessing systems. In a paper by Closs (Ref. 54), a model is presented for sizing the buffer requirements of a packet switch as a function of access lines and trunk line speed.

## 7. Architecture and Performance Modeling

Of central interest to teleprocessing decision making is the development of methods for studying and evaluating system organization and architecture. It is the lack of such a capability that represents one of the greatest difficulties. The six previous subsections outline pieces of the overall problem. In a sense, the question arises that given adequate subarea methodologies, how does one put them together?

A key manifestation of this issue is the current interest in projecting where the future trend will develop between the two different extremes: centralized superprocessing centers with smart terminals, or decentralized processing. The answer will clearly lie between the two; in fact, there may be several answers (i.e., operational teleprocessing systems) depending on the specialized needs of user communities and market conditions (i.e., technology and cost). A preliminary and simplified mathematical model is advanced in the paper by Streeter (Ref. 55). Principal aggregate parameters are identified (nodal processing power, network capacities, task delay, etc.) and cost performance/functionals are postulated for these parameters. The model assumes large regional ADP service centers that are interconnected to satellite subcenters. This concept of operation is similar to that of Ref. 2. The analysis proceeds with configuring the distribution of nodal capacity with regard to the postulated functionals for a given level of performance. The results of Ref. 55 show a definite trend to centralization.

A conceptually similar approach was taken in Ref. 3 where one or only a very few central systems were studied. Here, however, instead of postulating generalized cost functions for communications and system loading demand actual tariff schedules were used with more detailed terminal statistics. Consequently, "optimum" network topologies were obtained as part of the overall cost comparison. Littrell in Ref. 56, using test run simulation techniques, studies and compares the task throughput performance of the IBM 360/370 series computers.\* The studied machine tasks have the machines operating in a multiprogram

---

\*The validity of the simulation results is limited to these machines.

batch mode. In contrast to the results of Refs. 3 and 55, Ref. 56 shows no advantages in centralizing ADP for business-oriented (as opposed to scientific) data processing tasks. The different results follow from different assumptions, objectives, and projected (or capability-specific) processor capability.

For the interested reader, Ref. 57 discusses a study of upgrading an IBM 360/50 installation to a 360/65 or adding a communications front end to the existing 360/50. The principal utility of the paper is in exhibiting the detail of economic factors to be addressed, the heavy dependence on system simulation, and hence the dependence on the specifics of particular equipment. It is worth observing with regard to Ref. 57 that the simulation and evaluation programs used are proprietary to the author's parent company. One of their sources of business is supplying teleprocessing guidance to customer specific system configuration.

#### D. SUMMARY

Teleprocessing system design and analysis are very complex subjects with a very large number of variables and design options all impacting performance and cost. A good general understanding of the relationships between these variables is not available. Techniques and predictions of expected performance have developed within the context of current use of the telephony plant as a support element to a (set of) computer center(s). As such, the analysis is specialized by, and the results limited to, the particular configuration and operational constraints of specific vertically integrated systems. Only recently, as an outgrowth of ARPANET, are analytical design tools being evolved that are applicable to the study of subscriber-oriented data networks.

The design problem can be broken into three subareas: (1) user characteristics and demand, (2) ADP processing, and (3) communication network. All three areas, unfortunately, are highly interdependent. Conventional design of dedicated systems emphasizes areas (1) and (2) which generate data flow models. The communication network (3) is

then chosen to support data flow generated by (1) and (2) at least annual cost. These user and ADP areas specify network topological guidelines, operational constraints, and other system specific factors. The network objectives chosen and the resulting design then reflect these constraints. Whether designing dedicated vertically integrated systems or distributed common-user systems, the network configurations chosen, as to communication routes and bandwidth selection, are all dependent on transmission tariff schedules. (Changes in the tariff schedules will motivate network reconfiguration.)

On the other hand, design of common-user networks emphasizes separation between area (3) and areas (1) and (2). Moreover, in contrast to a dedicated design, generalized network objectives are required that are not as sensitive to specific subscribers (terminals, computers). This design process involves risks which as yet are not fully understood, especially in network access and flow control. Inadequate solutions to these problems can impede providing technically adequate and/or economically attractive data communication service to a sufficiently large community of subscribers to make the common-user network viable.

There are many possible modes for sharing communication facilities (e.g., access lines, concentrators, long-haul transmission) intermediate between dedicated and common-user networks. The user objectives and sharing arrangement will influence switching requirements. One of the more interesting sharing modes is a piggyback communications service provided by a large geographically distributed teleprocessing system to smaller systems.

A review of the technical literature with regard to network analysis shows considerable diversity of approach and interest with little coordination between research problems. Theoretical techniques are only in their infancy. There is a heavy reliance on computer analysis either for simulation of specific system configuration solution network using or intelligent exhaustive search (heuristic programming).

Initial comparisons between packet- and circuit-switching networks show dependence on user characteristics, types of data (transmission, bulk), load level, and geographic distribution, as well as sensitivity to technology, cost and comparison measure chosen. Packet technology does appear attractive. However, a hybrid packet- and circuit-switch design may be the most desirable approach for segregating bulk from transactional data, mitigating the access and flow control problem, and achieving flexible reconfiguration of the network to changes in user characteristics. Areas are identified in Section VII requiring future R&D effort.

## VI. COMPUTER AND DATA COMMUNICATION FUTURE ENVIRONMENT

This section and Appendix B present a summary of projected developments by the 1980s in communications facilities and computer equipment. It is important to have some estimate of the possible technical context from which teleprocessing components, systems, and applications will evolve and thus set the technical possibilities for data networks. Development of policies and alternatives for guiding the acquisition of teleprocessing systems in general, and in DoD in particular, cannot be insensitive to the direction in which communications and ADP activities are progressing.

This section reports on the efforts devoted to examining communication developments related to teleprocessing. However, because of the limited resources available to this study and the relevance and recent availability of the SADPR-85 (Ref. 2) study containing comparable projected developments in computers, it was decided not to expend further study effort on a computer technology forecast. This computer technology forecast and assessment were prepared by Arthur D. Little Co., under contract\* to AFESD (Air Force Electronic Systems Division) as part of the SADPR-85 effort. Their report is included as Volume 3, Appendix VI of Ref. 2. To make the present report self-contained, the summary of the ADL report as contained in Volume 1 of the SADPR-85 report is reproduced here as Appendix B.

---

\* Air Force Contract F19628-74-C-0093.

## A. COMMUNICATIONS

### 1. Introduction

The currently available communication transmission facilities and services are in a rapid state of transition. This section attempts to provide only a synopsis of the current situation and project developments of data communications. The principal emphasis, besides providing a communication context, will be to examine some of the potential impacts on teleprocessing network development that derive from expected changes in communications.

Present network design and planning are predicated on currently available communication facilities and existing tariff structure. New service offerings and tariffs are on file with the FCC from Common Carriers, and Specialized Carriers (including the VANS). Consequently, it seems appropriate first to review the present data communication environment and then project the expected future developments for impact on teleprocessing systems.

### 2. Current Environment

a. Current Telephone Plant. The current data communication environment is predicated on utilizing the transmission facilities of the existing analog telephone and data plant provided by the Common Carriers, principally the Bell System, GTE, and Western Union. For long-haul transmission circuits, this plant consists of a large mix of wideband cable and microwave radio transmission and tandem circuit switches. For local service and access to the long-haul circuit, the "twisted pair" telephone local loops connect the subscribers to a central telephone office of a local telephone company where calls are initially switched and individual local circuits are aggregated (multiplexed) into larger bandwidth channel groups for sharing the wideband long distance circuits. An example of the channel bandwidth multiplex hierarchy is shown in Fig. 27 taken from Ref. 58 which summarizes the AT&T facilities.

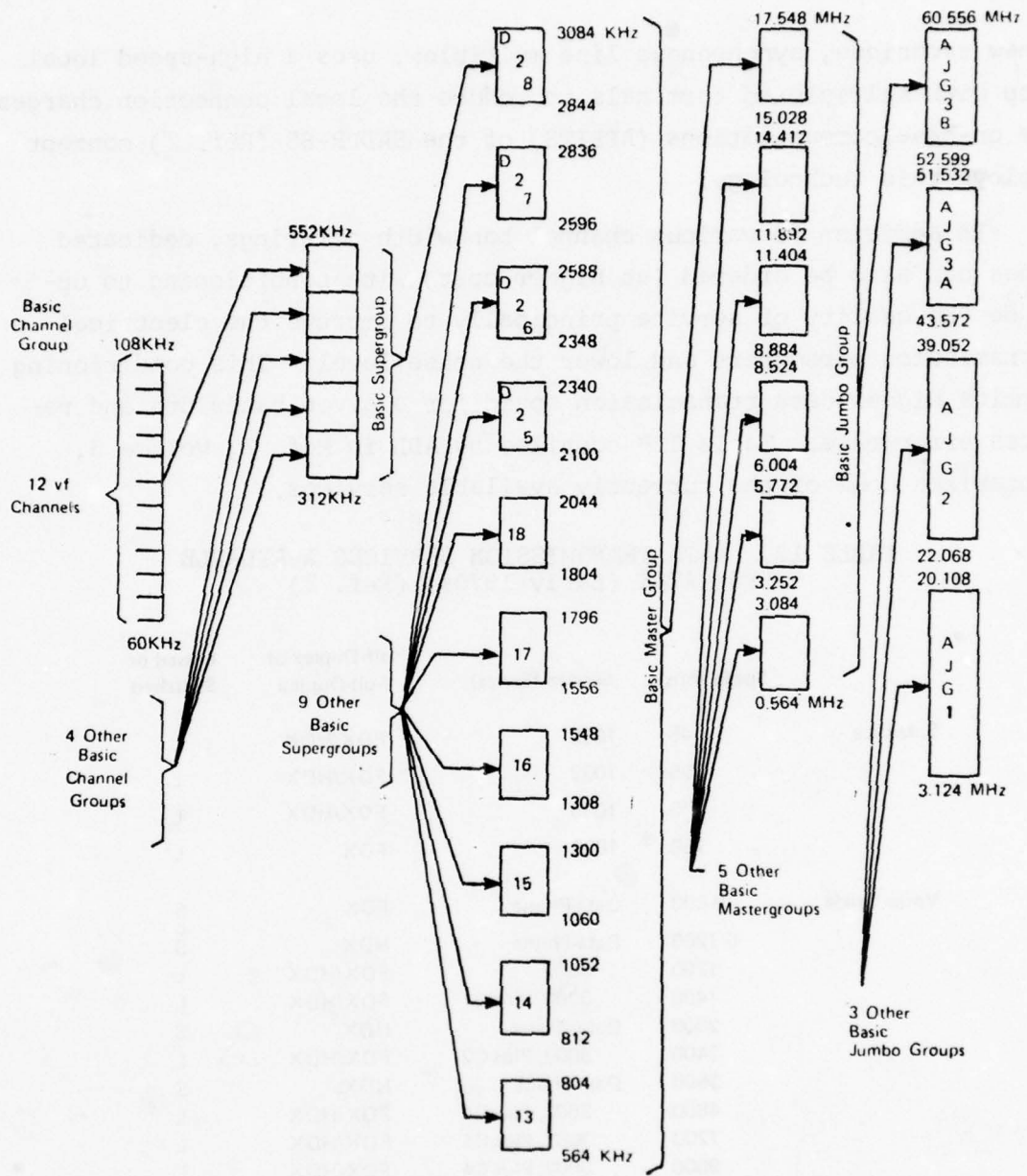

FIGURE 27. Analog Hierarchy (Ref. 58)

Current data communications utilize this plant through a basic 4-kHz wide-voice channel on a dial-up basis or on a dedicated lease basis (which allows obtaining wider bandwidth channels). Utilizing the basic voice channel usually permits using an existing local loop. Wider band dedicated service can require new local transmission lines.

A new technique, synchronous line multiplex, uses a high-speed local loop with multiplexed terminals to reduce the local connection charges. The on-base communications (AFBITS) of the SADPR-85 (Ref. 2) concept employs this technology.

In addition to various channel bandwidth offerings, dedicated lines can also be ordered (at higher cost) with conditioning to upgrade the quality of service principally to improve the electrical transmission parameters and lower the noise level. This conditioning permits higher data transmission speed for a given bandwidth and reduces error rate. Table 12\* compiled by ADL in Ref. 2, Volume 3, summarizes some of the currently available services.

TABLE 12. DATA TRANSMISSION SERVICES AVAILABLE FROM AT&T (Early 1970s) (Ref. 2)

	Speed (bps)	Service (Series)	Half-Duplex or Full-Duplex	Leased or Switched
Subvoice	45	1002	FDX/HDX	L
	55	1002	FDX/HDX	L
	75	1005	FDX/HDX	L
	150	1006	FDX	L
Voice Grade	0-300	Data-Phone	FDX	S
	0-1200	Data-Phone	HDX	S
	1200	3002	FDX/HDX	L
	1400	3002, Plus C1	FDX/HDX	L
	2000	Data-Phone	HDX	S
	2400	3002, Plus C2	FDX/HDX	L
	3600	Data-Phone	HDX	S
	4800	3002, Plus C4	FDX/HDX	L
	7200	3002, Plus C4	FDX/HDX	L
9600	3002, Plus C4	FDX/HDX	L	
Wideband	19,200	8803	FDX	L
	40,800	8801	FDX	L
	105,000	5700	FDX	L
	230,400	5700 or 5800	FDX	L
	500,000	5800	FDX	L

\*This table includes modem offerings which are subsequently discussed in this section. The C1, C2, and C4 indicate type of line conditioning.

b. Tariff Structure. The variety of the current Common Carrier transmission offerings have been standardized as to offered bandwidths, levels of conditioning, and full- or half-duplex circuits. To this is added a rather complex cost structure\* for the various available services. The structure revolves around fixed monthly connection charges plus time and distance charge for long-distance dial-up calls. For large volume use, the larger users can buy service in bulk with the wide-area telecommunication service (WATS) that provides dial-up service with its own (complex) tariff structure depending on volume level, distance, and time of day usage. For leased nonswitched dedicated channels, a structure of monthly tariffs per unit channel bandwidth per airline mile is imposed. This latter service when purchased in bulk quantities is typified by Telpak charges. [Note that dedicated service (e.g., Telpak) need not be limited to data. It is, in fact, used principally for private intracorporate telephony communications between geographically dispersed facilities of the corporation leasing the service.] A further complication in tariff structure is the differentiation between intrastate and interstate circuits.

A very significant cost-savings opportunity for subscribers with large bulk purchase of transmission capacity is the optimization of leased network topology to yield minimum cost for specific traffic-flow requirements. Considerable savings can be achieved (Refs. 59, 60) just through optimized aggregate bulk purchase of trunk capacity with optimization of the network topology. The optimum network topology chosen (node location and trunk linkages with associated bandwidth) is sensitive to the tariff structure and particular going rates within the structure. The optimization procedure is far from simple and is capable of exploiting the vagaries of the tariff schedule. Thus, significant changes in the tariff rates or structure are by themselves strong motivation to reconfigure a data network and system operation.

---

\* A simplified example of this tariff structure is displayed in Table 13 in the next section for the Bell System Digital Data Service (DDS).

As an example of some of the inconsistencies that have evolved within the tariff schedule, Fig. 28 (Ref. 61) shows averaged monthly unit-bit-rate cost with distance of various speed lines. In contravention to usual expectation, at a distance in excess of 350 miles, the per-unit-bit-rate monthly cost of the lower speed, 9.6-kbps line, is less than the 50-kbps line and at 2000 miles equals the 230-kbps line. Thus, excluding modem, terminal costs, etc., a customer who can subdivide his bulk purchase into units of 9.6 kbps is better off ordering such submultiples at distances greater than 350 miles than he would if he aggregated his buy into a 50-kbps line.

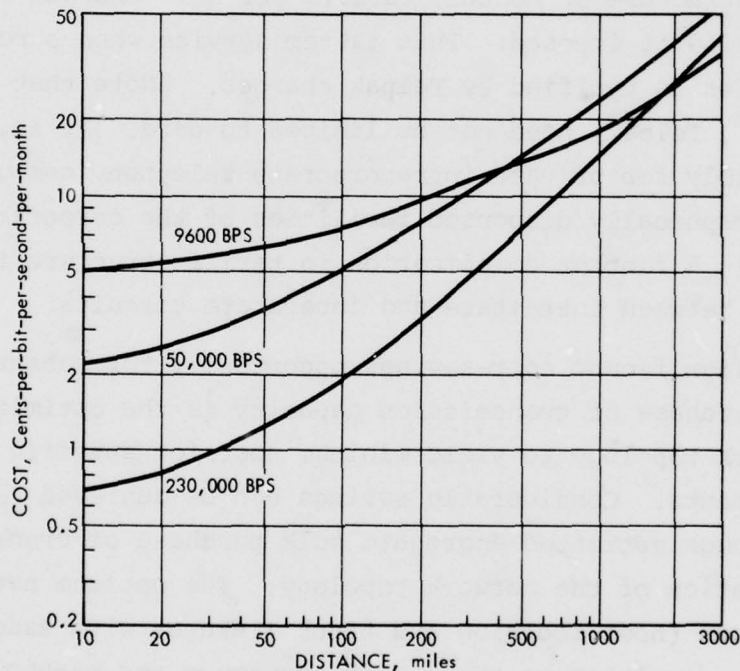

11-19-74-1

FIGURE 28. Average Unit Digital Transmission Cost Versus Distance for Three Bit Rates (Ref. 61)

c. Modems, Concentrators, Com Front Ends. Data transmission within the existing telephony plant must utilize modems to electrically convert digital signals utilized by ADP devices into signal waveforms suitable for transmission on the analog plant. There are numerous types of modems from well over 40 independent suppliers

(not including products available from the computer manufacturer, e.g., IBM, Honeywell, Burroughs, Singer, etc., and the Common Carrier, e.g., Bell System data phone). Communications equipment such as concentrators, multiplexers, and com processors (computer communication front ends) must be utilized in addition to modems and transmission lines to establish the desired network between host computers and their terminals. The principal objectives are to provide sharing of the transmission facilities with multiplexers and concentrators and off-load the burden of handling specialized communications functions and control from a CPU site with com front ends. The communication functions can be very costly in taking up considerable space of the CPU core memory as well as excessively burdening the operating system software. Communication functions are better performed by specially configured and programmed small computers which "front end" the host computer.

Enriching the available options and making complex the design choices for data transmission systems are considerable overlaps in network functions and available equipment. Terminals can have modems built in. Com processors can and usually do act as concentrators. One can multiplex before and/or after modems (i.e., on digital side or analog side). Industry surveys of existing data communications equipment and characteristics are given in Refs. 62, 63, and 64. In Ref. 65 a recent survey of minicomputers is presented.

d. Narrative Data (Telegraphy). The discussion above relates primarily to the use of the existing telephone plant. Also available for data transmission is the telegraphy plant\* of Western Union. Telegraphy transmits fundamentally digital data\*\* but is evolving

---

\* Historically, telegraphy and Western Union Telegraph Company considerably predate the telephony industry. Although Western Union is one of the larger U.S. corporations, the telephony industry and AT&T in particular have been growing for several decades at twice the rate of Western Union with the end result that the telegraphy plant is considerably dwarfed by the telephone plant.

\*\* Morse code can be theoretically considered to be built on a ternary base of no signal, short signal, or long signal. Modern digital codes are built on a binary base.

from the use of primarily an all-analog transmission plant to a hybrid analog/digital service. (The features of digital service are discussed in the ensuing text.) A comprehensive review of Western Union plant and offerings including long-haul transmission as well as store-and-forward (Telex, TWX, Infocom) service is provided in Ref. 66. Figure 29 depicts the geographical coverage of Western Union's wideband transmission system. The previous discussion as to the use of the telephony plant for data transmission also applies to the telegraphy plant. It is important to note, however, that Western Union is providing a switched, store-and-forward, common-user, subscriber-oriented narrative-data network service through TWX and Telex. For Federal Government use the ARS and AUTODIN I systems leased from Western Union provide this narrative data service. These systems are currently also being used for the transmission of primarily bulk-type ADP data. However, due to their long response time, these networks are not suitable for transactional or inquiry/response ADP traffic.

e. Local Connection. It is important to note here that although Western Union and the newly emerging specialty carriers provide a backbone long-haul facility, a subscriber still must connect from equipment on his premises to the nearest access point of the network he is going to utilize. Unless the particular facility requires a very high access speed or is collocated with the network, the subscriber will have to traverse the Common Carrier local telephone plant to make the connection or provide his own connection. Thus, without obtaining independent means of network access, the user's communications are ultimately limited by the capabilities and availability of the local telephony plant.

There are two major implications: one is cost, the other regulatory. The cost issue is that conventional modems may still be required\* to traverse the telephony local loop even if the data network

---

\* Modems can be eliminated when direct physical connection is permitted to the Bell System's all-digital local carrier facilities (e.g., T-1) as discussed in the subsequent subsection.

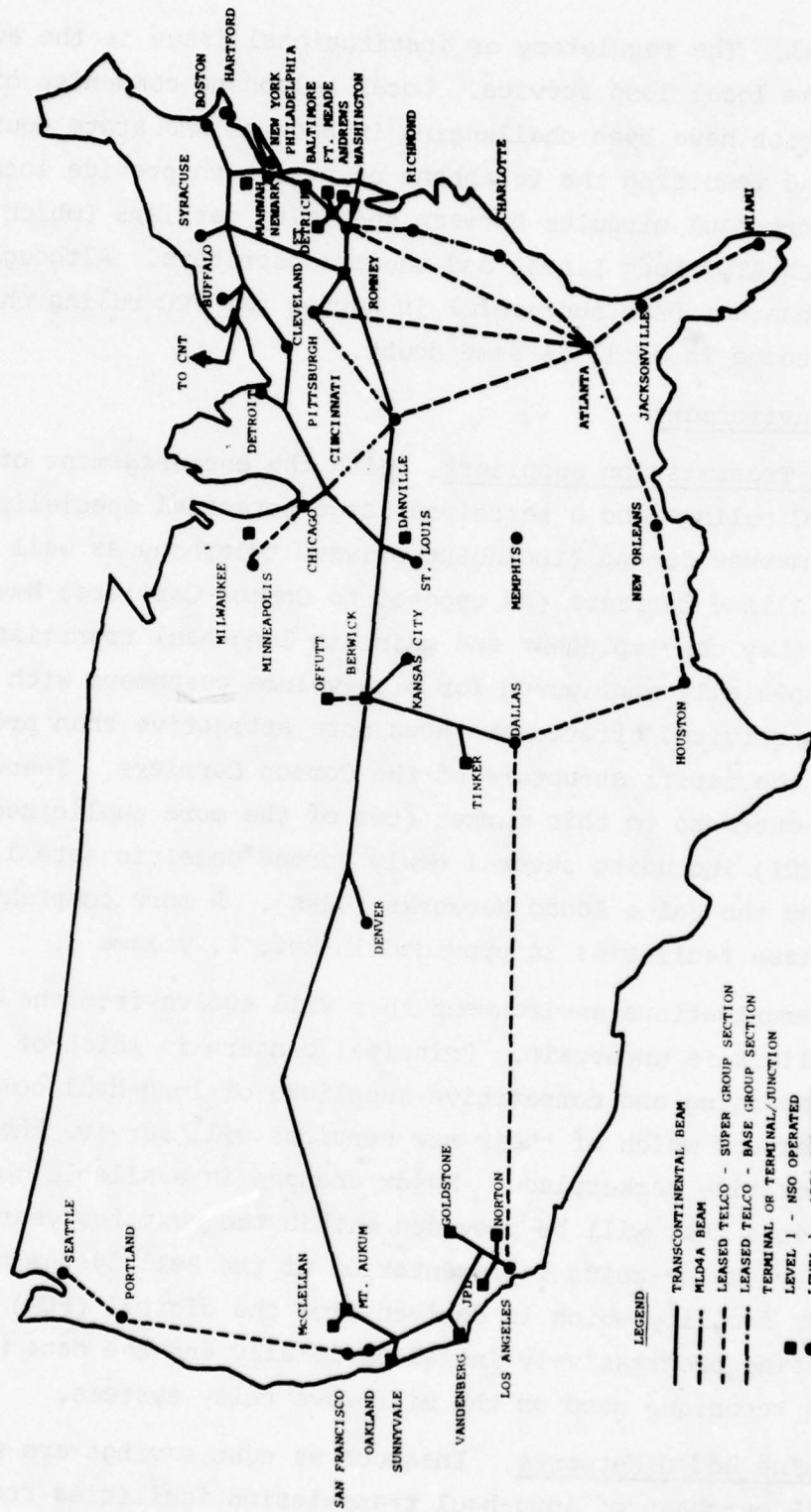

FIGURE 29. Western Union Telegraph Co. Wideband Systems (Ref. 66)

is all digital. The regulatory or institutional issue is the availability of the local loop service. Local telephone companies of the AT&T Corporation have been challenging in Federal and state courts the FCC ruling requiring the telephone companies to provide local loops and short-haul circuits between specialty carriers (which are competing with AT&T Long Lines) and their subscribers. Although AT&T as yet has not been successful in having the FCC ruling changed, the final outcome is still in some doubt.

### 3. Future Environment

a. New Transmission Suppliers. With the encouragement of recent favorable FCC rulings and a perceived large potential specialized communications market demand (including private telephony as well as data), Specialized Carriers (as opposed to Common Carriers) have concluded that they can implement and maintain long-haul transmission facilities specially configured for high-volume customers with leased transmission services offered at rates more attractive than presently exist under the tariff structure of the Common Carriers. There are quite a few entrants to this market (two of the more publicized being DATRAN and MCI) including several newly formed domestic satellite companies and the Value Added Networks (VANs). A more comprehensive review of these facilities is provided in Ref. 2, Volume 3.

The communications environment that will evolve from the entry of new suppliers is uncertain. Principal concern is which of the many newly emerging and competitive suppliers of long-haul communication services and which of their new services will survive the test of the competitive marketplace. Major changes in available communication services that will be provided within the next few years are guaranteed by the on-going implementation of the Bell System's "all-digital" DDS facility which is derived from the digital (PCM) voice telephony being progressively installed locally and the data under voice (DUV) technique used on the microwave relay systems.

b. Value Added Networks. Inasmuch as cost savings are possible through bulk purchase of long-haul transmission facilities from the

carriers but only with point-to-point service, a group of Specialized Carriers is forming to provide switching, concentrating, and other (e.g., error control) data transmission services as a value-added service to the basic long-haul transmission. These Value Added Networks (VANs) purchase from the carriers point-to-point bulk transmission and add the switching and other services at nodal points. There are several corporations planning to offer such service including GRAPHNET, TELENET, and PCI among the more publicized. The newly forming\* VANs, to varying degrees, utilize packet-switching concepts and technology developed for the ARPANET. Inasmuch as these VAN networks, although licensed for operation by FCC, are still in a development stage, subscriber data interface standards, types of service, geographic coverage, and tariff schedules are not yet finalized.

One VAN, TYMNET, is currently providing operational service to ADP subscribers. TYMNET (Ref. 11) is an outgrowth of TYMSHARE, Inc., a commercial ADP time-sharing service which made available, in a piggy-back model, portions of its intrinsic data communications support network for interconnection between subscribers possessing their own (rather than TYMSHARE) ADP assets (computers as well as terminals). The TYMNET network was developed independently by TYMSHARE and was not derived from ARPANET. The network objectives in seeking to minimize subscriber interface problems led to a design concept of emulating circuit-switched characteristics with a packet-type transmission that permits statistical multiplexing of transmission circuits. Rather than use adaptive routing, paired subscriber call requests are assigned a route which is stored in tables at the switching computer nodes. The route is retained in memory until the call is taken down. However, trunk transmission capacity is only used "by the packet."

---

\* It is important to note that predating ARPANET, a privately operated value-added packet-type network, SITA, has been successfully in use. A description of SITA and contrast with ARPANET is given in Ref. 20.

The VAN concept closely resembles a common-user data network such as DoD might employ. The development, evolution, and operational experience of the VAN concept should be of considerable interest to DoD for potential use and/or technology transfer.

c. New AT&T Transmission Offerings. In partial response to the emerging competition in supply of communication services, AT&T has filed with the FCC a new tariff structure known as the Hi/Lo Density Rate. With FCC approval, the AT&T rates would be reduced on those routes with high-traffic density and increased on those routes with low-traffic density. Data subscribers would still utilize the present analog telephony plant but with drastically altered tariff structure. If accepted, and with no change in transmission facilities or service, this proposed tariff change in its own right will produce a strong motivation for subscribers with significant data transmission needs at the very least to reoptimize their current network configurations and alter their mode of operation to include reconfiguring computer facilities and terminals.

AT&T is in the process of implementing their Digital Data System (DDS) network. This data network is already offered locally in ten cities and will expand to cover approximately 99 major U.S. cities by the end of 1976. A tentative plan for geographical coverage by the DDS network for 1975 is shown in Fig. 30. At present the only announced service offered is leased point-to-point data transmission in multiples of 2.4-kbps data speeds. An illustrative example of the proposed point-to-point tariff structure for this (Ref. 2) is shown in Table 13.

AT&T has not publicly announced any plans for providing data switching service in the DDS. It is possible\* that at some future

\* The Bell Labs have disclosed (Ref. 67) development work on the ESS #4 switch which will be an all-digital time-division trunk circuit switch which will support conventional trunks as well as PCM carriers (T-1). The switch controller (which it is asserted can be back-fitted to earlier electronic cross-bar switches) is claimed to be able to process call requests three times faster than previous switches. This technology offers a potential base for providing "fast" circuit switching to data subscribers.

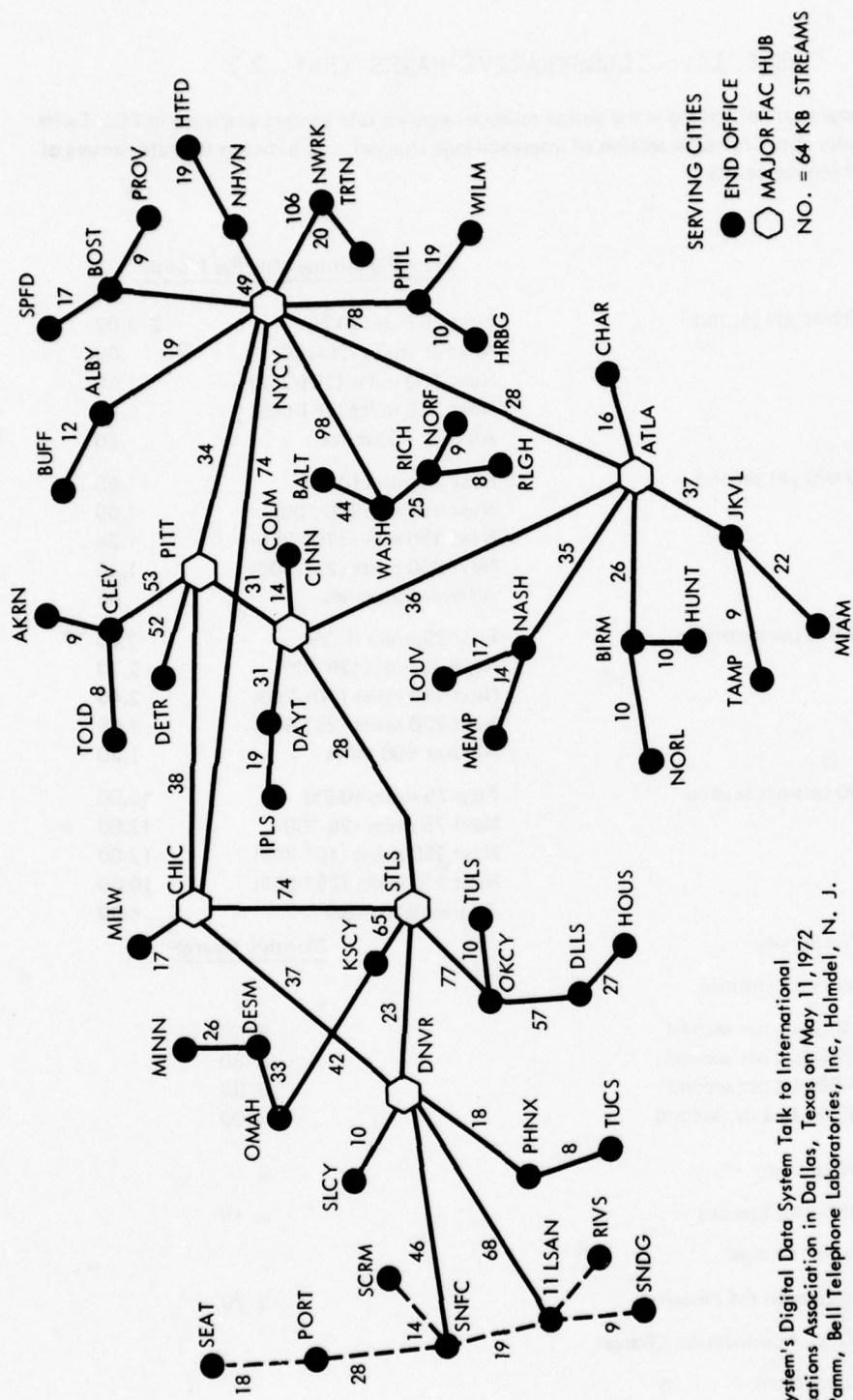

SERVING CITIES  
 ● END OFFICE  
 ○ MAJOR FAC HUB  
 NO. = 64 KB STREAMS

Source:  
 The Bell System's Digital Data System Talk to International  
 Communications Association in Dallas, Texas on May 11, 1972  
 by L. R. Pamm, Bell Telephone Laboratories, Inc, Holmdel, N. J.

FIGURE 30. 1975 Tentative Digital Data System Network

TABLE 13. ILLUSTRATIVE RATES (Ref. 2)

Interexchange channel pricing is the airline mileage between rate centers as shown in FCC Tariff 255. The rates apply for each section of interexchange channel, i.e., between the rate centers of each pair of service points.

	<u>Rate Per Airline Mile Per Month</u>	
2,400 bits per second	First 25 miles (0-25)	\$ 1.00
	Next 75 miles (26-100)	.90
	Next 150 miles (101-250)	.80
	Next 250 miles (251-500)	.65
	All over 500 miles	.40
4,800 bits per second	First 25 miles (0-25)	1.65
	Next 75 miles (26-100)	1.50
	Next 150 miles (101-250)	1.35
	Next 250 miles (251-500)	1.10
	All over 500 miles	.65
9,600 bits per second	First 25 miles (0-25)	3.00
	Next 75 miles (26-100)	2.70
	Next 150 miles (101-250)	2.40
	Next 250 miles (251-500)	1.95
	All over 500 miles	1.20
56,000 bits per second	First 25 miles (0-25)	15.00
	Next 75 miles (26-100)	13.50
	Next 150 miles (101-250)	12.00
	Next 250 miles (251-500)	10.00
	All over 500 miles	6.00
Service Terminals:	<u>Monthly Charge</u>	
Per Service Terminal		
2,400 bits per second		\$ 60
4,800 bits per second		\$ 80
9,600 bits per second		\$ 80
56,000 bits per second		\$100
Data Service Unit:		
Per DSU (All Speeds)		\$ 15
Multi-Station Charge:		
Per Station on the circuit		\$ 20
Analog-Digital Connection Charge:		
Per Connection		
2,400 bits per second		\$100
4,800 bits per second		\$200
9,600 bits per second		\$200
56,000 bits per-second		\$200

date AT&T will offer a switched DDS capability. The time frame for introduction, the technical characteristics, and the cost schedule for switched DDS cannot but have profound effects on data network planning. The current lack of information as to future DDS services, especially switched services, introduces considerable uncertainty in planning future teleprocessing systems.

The DDS transmission system, as is the conventional telephony plant, is composed of two major segments: the local distribution or access loops and long-haul transmission. The data subscriber provided here is located on a T-1 carrier route and will be able to directly access the DDS through a digital interface unit. The T-1 carrier system is a local-area, digital, very-high-speed transmission system originally designed for digitized (PCM) voice. The T-1 carriers employ basic capacity units of 1.5 Mbps. PCM voice and data channels are time-division multiplexed onto the T-1 carrier. Data channels are available in multiples of 2.4 kbps--the slowest data speed offered.

Long-distance transmission in DDS can be provided in either of two basic ways. The conventional method is to utilize available wideband analog facilities with high-speed modems to carry the digital data much as it is done today. A new method of transmission, data under voice\* (DUV), makes additional utilization of the existing microwave radio relay facilities. Advantage is taken of excess power margin and available spectrum in the existing microwave radio relay system. The digital (sub)carrier is frequency multiplexed between the microwave carrier center frequency and the frequency of the lowest telephone channel in the trunk group. (The unique robustness of the digital signal to nonlinear induced self-interference

---

\* Future transmission media under active research include millimeter wave cables and optical fibres which offer the potential for providing digital carrier capacity up to a gigabit per second.

allows utilizing this spectral slot not usable by the analog telephone channels.) DUV provides the exceptional saving in acquisition cost as only modest electronic changes are required to the already installed microwave relay plant. This provides an opportunity for providing DDS long-haul services at considerably lower cost.

A key feature of the DDS will result from the use of the local all-digital T-1 carrier. Since the T-1 is all-digital those subscribers located on a T-1 route gain access to the T-1 carrier through a logical interface and control unit rather than a modem. DDS subscribers will have available for use a self-synchronous data line with a minimum speed of 2.4 kbps. Moreover, the multiplexing of integral units of 2.4 kbps can be provided by the carrier.

The principal initial functional impact of DDS will follow from reductions in data transmission costs with improved transmission quality. Just as with lower rates from Specialized Carriers and the new AT&T Hi/Lo tariff (if approved), existing teleprocessing networks will be strongly motivated to topologically reconfigure in order to take economic advantage of reductions in transmission cost. The new technical features of DDS will have a lesser initial impact on existing teleprocessing systems. A combination of increased ADP workload and cost reductions in advanced terminals will pace modifying existing teleprocessing systems in order to fully utilize the DDS technical capabilities.

On the other hand, teleprocessing systems and data networks in planning or under development will be more strongly influenced by DDS. The synchronous higher line speed with lower error rate will impact principally on the access-line interfaces of terminals, concentrators, and com front ends ultimately affecting their hardware architecture, capacity, and software. Interfaces with long-haul wideband trunks will not be impacted as strongly as they already tend to be synchronous high-speed facilities. The DDS will affect design of common-user networks, such as the VANS and AUTODIN II, principally at the network access nodes where both DDS and conventional access lines will be terminated.

Of even greater potential significance to the future development of teleprocessing systems and common-user networks would be the introduction of data switching features to the DDS. In effect, a switched DDS would be providing a common-user data network and thus could be competitive to the VANs. Utilization of a switched DDS is so strongly dependent on the cost, availability, and especially the performance characteristics of the switching service to be provided that its full impact cannot be projected (fast circuit, virtual circuit, packet, hybrid, etc.). Aside from affecting network configuration and organization, the most immediate impact of a switched DDS would be on the design and usage of concentrators and com front ends. These qualitative effects hold for any common-user switched data network but take on added qualitative emphasis when considering such a service offering from AT&T.

There does not appear to be any technical impediment to providing a switched DDS although doing so may not accord to AT&T policy or marketing strategy. Lack of any written indication on the part of AT&T to even provide any switched services on the DDS (or any other Bell System data transmission services) is perhaps the most relevant current fact.

d. Device Technology. Since communications processors, e.g., concentrators and front ends, are specialized versions of computer processors, they will be affected in much the same manner as discussed in Appendix B. The signal processing and control elements (as opposed to power supply and amplification) of modems are also exhibiting an accelerating use of digital implementation to take economic advantage of large-scale integration (LSI) technology. A logical outcome of such a trend would be the direct incorporation of the modem function into new terminal, com front end, and concentrator (or "switch") designs. The development in microprocessors and active memories will also maintain the progress toward smart terminals at lower cost, i.e., terminals with resident memory and logic capability. Nonpermanent display technology for terminals, especially alphanumeric

displays using plasma, liquid crystal, or light-emitting diode technology, is expected to support the trend toward lower cost/higher performance terminals. On the other hand, significant cost reductions in high-performance permanent-copy devices (e.g., printers, cards, tape) are not expected.

Perhaps one of the most significant potential areas of technology impact is in switching. The general trend toward supplanting general-purpose processors, with software, replicating specialized hardware and firmware, would appear to be very applicable to the functional requirements of switching, whether packet, circuit or hybrid. Discussion of the use of arrays of microprocessors and active memories for configuring data switches has not appeared in the literature. To date, data switches described in the literature have been developed out of the minicomputer technology which conceptually and functionally emulates (in the small) a late third-generation computer. Since switching implies repetitive processing of input and output arrays, fundamentally new data-switch architecture and design, based on LSI and new memory technology, would appear likely. This is discussed further in Section VII-C.

#### B. SUMMARY

The trend in ADP technology (Appendix B) clearly points toward lower equipment costs. Since there are no indications of a trend to lower software development costs, a shift in emphasis to use more specialized hardware for firmware in systems may develop. This trend can coexist with the familiar general-purpose approach to processing. It is not at all clear as to what the balance between these two trends will be. The role of centralized versus decentralized processing is of primary interest to data networks. It seems likely there will be both centralized computer centers and distributed processors; however, the functions, tasks, and interactions between the two will dominate future data communications. Projections to date, such as those in Refs. 1 and 2, tend to be conservative being based on the accumulated

ADP experience to date. Major new ADP user developments are sure\* to occur but high-confidence predictions as to their nature cannot as yet be made. It appears that we are once again in a major generational period of ADP change (third to fourth). However, it is unlikely that as in the past the newest generation (fourth) will displace the previous equipment. Networks will have to support both generations concurrently.

The current communications environment is dominated by the characteristics of the existing analog telephony transmission plant and the tariff structure of the Common Carriers. Terminals, modems, and specialized small computers (i.e., concentrators and com front ends) have evolved for use with the Common Carrier transmission plant to configure a data communication network as a component of a specific teleprocessing system. New Specialized Carriers are being encouraged to offer communication services by perceived market opportunities and a regulatory policy favorable to developing market competition. The principal immediate effects, already manifest in the new AT&T Hi/Lo density tariff changes, will be accelerated changes in both the tariff rate and structure for data transmission. Changes in the communication pricing structure in and of itself create considerable motivation for existing teleprocessing systems to reconfigure their communication networks in order to exploit reduced costs.

A class of Specialized Carriers, the VANS, are proceeding with development of subscriber-oriented common-user switched data networks based on adding special nodal facilities to leased dedicated transmission facilities from the carriers. With one exception, TYMNET, the other VANS (TELENET, PCI, GRAPHNET, etc.) to varying degrees are derived from ARPANET packet-switched technology and are just

---

\*The sweeping effects of the personal calculators and "smart" measurement instrumentation based upon microprocessor technology, not to mention Point of Sale systems, support this assertion.

beginning operations. Consequently, connection interface standards, geographic coverage, and tariff cost schedules are still evolving. The TYMNET network, having several years of operational experience, provides packet transmission with a switching concept that emulates the characteristics of circuit switching and yet obtains dynamic sharing (statistical multiplexing) of the transmission circuits.

The introduction of the new Bell System DDS facilities utilizing T-1 local carriers and data under voice (DUV) with only leased point-to-point service (no data switching) can be expected to further the trend toward restructured transmission tariff charges. The all-digital nature of the T-1 carrier providing a considerably enhanced synchronous base-band data transmission service is consonant with the trend toward smart terminals and improved computer com front ends. Of even greater significance would be the introduction in the near future of switched service on the DDS. Since a switched DDS would provide a pervasive subscriber-oriented common-user data network of considerable geographic coverage and capacity, it would have major impact on the general competitive evolution of the data communications market, user teleprocessing planning activities, and the course of technology development, both hardware and software. To date, the possibility of DDS switched service is speculative. As yet, there has been no indication by AT&T that introduction of switched service for the DDS is planned, let alone the nature of the technical characteristics of such service (e.g., fast circuit, store-and-forward, hybrid).

The computer driven technologies in circuits, memories, and displays will generate strong economic pressures toward the production of the conversion to lower cost smart terminals (or terminal "systems") with enhanced processing and memory capabilities. This will further the overlap between and blur the conventional separation of function and equipment. Of special interest is the potential impact of the rapidly emerging hardware technology and cost trends on developing new concepts of data switches. Current packet and (electronic) circuit switch design concepts considerably predate the evolving microprocessor

and active memory technologies. Conceptually, new approaches in data switch design with a hardware as opposed to software emphasis would be timely, especially for a mixed circuit/packet function.

Overall, the future communications environment is characterized by uncertainty. The competitive outcome of new types of service, their geographical extent, and the economic viability of the supplier cannot be predicted. Although the trend in communication transmission costs is downward, the specifics in structure and rates are not clear. Introduction in the future by AT&T of switched service in the DDS could have a profound impact on the development of teleprocessing technology and balance between dedicated and common-user networks.

## VII. SELECTED SYSTEM R&D ISSUES AND NEEDS

In the previous sections, numerous design and evaluation issues have been raised that relate to teleprocessing data networks. The purpose of this section is to bring these together and to provide suggestions for technical activities relating to subscriber-oriented data networks to aid in the development of a coordinated research and development effort within DoD.

### A. REQUIREMENTS, ACTIVITY MODELING, AND SYSTEM EVALUATION

In Section IV, the requirements formulation within DoD was reviewed and inadequacies revealed that pertain to design of teleprocessing systems. As more comprehensive data describing user ADP tasks or functions are made available, it will be necessary to translate these needs into technical specifications of generic types of basic processing and data transmission functions and to relate these to communications requirements and network organization. In order to achieve this translation, mathematical models relating user activity, computer actions, data organization, and resulting communication traffic will have to be developed or refined. Not only are such models of direct use in design of specific systems but they can have significant bearing on aggregating users into networks. Moreover, such models will be necessary in the design of meaningful test and evaluation procedures for data networks and interpreting their results for subscriber implications.

The current probabilistic descriptions of data (e.g., message occurrences--Poisson, message length--geometric, component reaction times--exponential, etc.) are guided by what appear to be physically plausible and mathematically tractable. There have not been collected

any extensive real data on the statistics of system use and performance (excepting Refs. 68 and 69 which report on data statistics for a single paired computer remote-terminal connection). Prior to the acquisition of concrete data and during the initial development phase of any pioneering technical activity, one has no recourse but to postulate idealized models. However, it is reasonable now to consider how more realistic models can be developed and experimental data obtained.

Along with a needed capability to relate user ADP task requirements to teleprocessing functions and data traffic flow, there is a broader need to develop capability for evaluating system performance. Hopefully, the mathematical disciplines and methods useful to system evaluation will bear considerable similarity to those used for traffic modeling. In the development of an evaluation theory, it will be necessary to identify key parameters or measures of performance (there are many potentially useful measures) and discover their characteristics and the relationships between measures. For example, measures may exist which in effect are equivalent. It is of use to discover what these are and what "equivalent" means. Currently, performance is measured by criteria (e.g., channel miles, response time, buffer requirements, ADP task throughput) chosen by the owner, user or analyzer of a particular system according to the dictates of his system configuration and his specific interest or even in an ad hoc manner. Further, performance is predicted based in many cases on simulation as well as mathematical analysis. Consequently, comparisons between like systems (what are like systems?) are difficult.

A further consideration is the need to obtain standard methods of describing requirements and systems performance to support major policy formulation and decision making at higher management levels. One of the principal potential benefits afforded by teleprocessing capabilities is the opportunity to reaggregate ADP tasks and functions in order to reduce costs and/or manning. An important corollary benefit of a requirement methodology would be to help standardize utilization reporting profiles from the diverse ADP activities.

## B. DATA INTERFACE STANDARDS

### 1. Introduction

A key problem in data communications is the interface (electrical, transmission, logical) between the data user end points (terminals, computers) and the communication media. An intimately associated problem, which is sometimes subsumed under the interface problem, is the method of access by a remote user (terminal or other computer) to a computer and the control of that access. Those systems which use dedicated transmission facilities or the dial-up voice band circuits\* of the Common Carriers have available to them considerable flexibility in solving these functional problems.

The attractiveness or acceptability of a common-user network by a potential subscriber will be heavily weighted by the relative "transparency" as perceived by the subscriber of the network. The common-user data network tends to reduce the interface and control flexibility\*\* available with dedicated or dial-up circuits. The subscriber's interest in a common-user network is solicited by the reduced communication costs and wider degree of connectivity to other subscribers offered by the network. The viability of a common-user switched communication network is heavily dependent on adopting a uniform and widely accepted set of network/subscriber data and procedural interface standards and access control mechanisms that do not incur unacceptable economic or performance penalties. The access control and interface standards utilized can have heavy impact on subscriber hardware, software and task or applications performance (e.g., job throughput, interactive terminal response time). Subscriber utilization, in return, has direct effect on network design, internal control, and growth.

---

\*To date this represents the vast majority of implemented systems. The ARPANET and VAN represent a new departure.

\*\*A current example of this restriction is provided by the control complexity of a polled access line.

## 2. Current Context

Motivated by a desire to connect as wide a variety of terminals to available computers as possible, industry has strong incentives to adopt certain standards (more accurately a limited set of differing standards). The present standards are all characterized as having evolved in the context of dedicated or dial-up circuit transmission facilities. These standards have dealt with various transmission speeds, modulation waveforms, half- or full-duplex lines, synchronous or asynchronous terminals (modems), error control, and direct or polled access lines. In addition, various definitions of alphanumeric character (bit code) and data format and structure have been specified. Considering the wide variety of end user equipments with the multiplicity of communication transmission, several differing sets of standards have evolved with the terminal manufacturers attempting to incorporate within their equipments as great a flexibility as possible to adapt\* to the various standards utilized. An excellent guide to the current existing standards is provided in Ref. 70.

Generally speaking, the standards evolved to date do not emphasize a careful differentiation between the subscriber end-point control and the transmission path control (i.e., computer and terminal logic interaction as differentiated from the interaction between transmission path and terminal or computer). Emphasis on this distinction has not been necessary in the current communications context provided by dedicated or dial-up telephone facilities. Line and end-point control, as well as the interface, have been the responsibility of the individual teleprocessing system and allow the greatest flexibility in implementing the interface and control most suitable to a specific system. On the other hand, this flexibility seriously restricts the ability to cross-connect computers and terminals from differing systems as well as tending to capture an evolving system to a product line.

---

\* In many cases, at time of customer delivery, a terminal has a fixed interface module installed matched to the standards prevalent on the purchaser's system.

For dedicated point-to-point transmission, the communication supplier provides a permanent line-connect of stated speed and quality between designated points. For dial-up service, the Common Carrier additionally provides the usual signaling and supervisory services for switched telephony, such as routing, destination ringing, busy signal, and circuit completion disconnect. Present centralized tele-processing systems with tight integration between their computer and terminal equipment provide the following types of functions:

- Electrical interface with the line
- Verification of presence and status plus conduct of logic dialogue between line end points including send/receive protocols
- Maintenance of end-to-end bit or character error control and framing
- Provision of recovery mechanisms for logic error states
- Monitoring of facility status.

Additional functions are required when a basic transmission path is shared by several to many users in an attempt to reduce their communications cost. This, typically, is exemplified by polled lines; that is, a long string of terminals shares a single "party" line and a master station, usually a computer, controls the access and "conversation" of the sharing terminals with a variety of round-robin polling techniques. Another typical method of sharing transmission facilities is with the use of a concentrator. Here the sharing terminals are connected by (usually individual) short "local" paths to the concentrator, a relatively complex device (small- to medium-size specialized computer), which then multiplexes the terminals on a demand basis to dynamically share the long-distance communications path. This arrangement reduces the interface and control as seen by an individual terminal to that of a direct local access path to a computer since the concentrator on the terminal side emulates a computer input. On the other hand, a new set of control and data protocol requirements is generated to interconnect the concentrator with a computer.

Differentiated from transmission path control (i.e., signaling and line supervision), the data transmission standards that have evolved to date can be categorized as follows:

1. Definition of Transmission Path Characteristics
  - Point-to-point, multipoint, half or full duplex
  - Line speed, quality
  - Waveform modulation, synchronization
2. Data Structure
  - Character/bit code
  - Frame or block structure, header, text, end
3. Logical Sequence Structure
  - Send/receive protocol (including polling technique)
  - Transmission error control
  - Logic error recovery

Category 1 relates to transmission lines and modems; category 2 deals with common interpretation of data bits; and category 3 deals with common logical procedures. To date, category 3 has the least comprehensive and widely accepted set of standards. Category 3 exemplifies the dilemma of customizing a design to achieve efficiency and performance versus standardization to allow widespread interoperability between subsystem components.

### 3. ADCCP Example

An example data standard which is illustrative of the relationship between categories 2 and 3 above is the ANSI-proposed\* Advanced Data Communication Control Procedure (ADCCP). The ADCCP defines a data structure which is relatively independent of category 1. Given an acceptable transmission of raw bits, ADCCP groups these bits into variable length frames with the following structure:

- Frame start (flag) of a standard fixed pattern of eight bits
- An address block of eight variable bits (hence no more than  $2^8 = 256$  addresses, less with redundancy for address protection)
- A control block of eight variable bits

---

\* This standard has not yet been adopted for international use although it has been under intensive development and consideration for several years.

- A text block of variable length
- A frame check block of 16 bits for error control
- An end-frame flag of eight bits identical to the frame start flag
- A standard text-scanning and bit-stuffing procedure for preventing a text bit pattern identical to the flag from indicating an erroneous frame end.

In addition, the ADCCP standard delineates a specific set of control block bit codes and logic procedures for controlling the dialogue between terminal and computer including the functions listed in category 3. IBM has announced adoption of a new data standard, Synchronous Data Link Control (SDLC), which is formatted the same as ADCCP (Ref. 71). However, the SDLC control block and logic procedures may differ from ADCCP in error control and polling procedure. This, in turn, could affect the terminal/computer interface and throughput performance.

The ADCCP and SDLC interface standards are the result of an evolutionary process of major improvements in data terminal technology taken within the context of autonomous centralized computer facilities utilizing the Common Carrier telephony plant. The newer terminals utilize data buffers which permit the more efficient transmission of data blocks as opposed to the older technique of character-by-character transmission. The frame error control procedures\* and, for polled

---

\* The error control is end-to-end and utilizes the frame error control block to detect any errors in the frame. If an error is detected, a request is made to retransmit the frame. Thus, in addition to the minimal buffer memory needed by a terminal to accumulate each frame, the largest need for memory space is dictated by the requirement to hold the already transmitted frame in storage against the contingency of an error upon reception. There are a variety of retransmission strategies, all of which involve a trade between terminal complexity and throughput. A common strategy, which is one of the simplest in buffer management, is to keep sending indexed data frames without waiting for acknowledgment of correct reception. When a received error causes a request for retransmission of a specific frame, the transmitter indexes back to the requested frame and retransmits that frame and all succeeding frames whether received correctly or not. This simplifies terminal buffer organization and management at a loss of throughput (retransmission of correct frames).

lines, the polling procedures have significant impact on the organization, sizing, and management of these terminal data buffers, and this affects the performance of the terminal and communications throughput. Master control of the terminal usually resides in the computer facility (or concentrator).

#### 4. Network/Subscriber Interface

It is through the concentrator approach that the commercial time-sharing computer service companies provide a common-user service between subscribing terminals and the computer facility (Ref. 21). In this regard, the common-user interface is between the terminals and concentrator. The rest of the system--computers, concentrators, and long-haul communications--is under the control and direction of the computer facility as an integral whole. Here the communications are an essential component of the teleprocessing system for which the computer facility is the focus of the system. A common-user communication network, such as ARPANET and the VAN, takes the additional step of making the computer a subscriber to the network, separating the computer facility from its dominant role over its communications support. This, then, generates the need for consideration of a new interface dimension--that between the computer as a subscriber and the network.

It is not clear as to the degree to which standards for the computer/network interface can be established separately from, or identical to, the terminal/network interface. A basic issue to be examined for the common-user network is the interface standard architecture. Can a single common overall network interface standard for both terminals and computers be implemented which is efficient and economically acceptable to potential subscribers, or is a more complex hierarchical set of standards required which differentiates between computers and terminals? In this context, the functions of network access and transmission path control must be differentiated from subscriber end-point control.

As an example, any fast store-and-forward type of common-user data network (e.g., ARPANET-derived networks) has the potential for overlapping responsibilities with ADCCP/SDLC type standards in at least the following areas:

- Addressing
- Start/stop control (especially for polled lines)
- Error control
- Failure recovery.

The separation and coordination of responsibilities between the network and subscriber must be given study. For example, independent of the subscriber, store-and-forward switching must utilize error-control and retransmission techniques internal to the data network. Thus, important considerations are requirements for subscriber-maintained error checking and resulting interaction with the network.

Either or both of the ADCCP and SDLC interface standards can be expected to be widely utilized in the future by ADP manufacturers. It is extremely important that interface standards and access control for a DoD common-user subscriber-oriented communication network (such as the AUTODIN II concept) be thoroughly examined for the degree of compatibility with ADCCP or SDLC and to identify resulting design features and performance factors which have impact both on subscriber and network operation. In Ref. 72 an initial examination of these issues was undertaken for WWMCCS computer networking.

The principal areas of concern with regard to overlapping subscriber and network control responsibilities for any common-user data network would appear to be in error control and failure recovery. If polled terminal access lines are used to connect to the common-user network, then start/stop control would also be a primary concern. These control functions have time-dependent logic activities between subscriber end points (computer and terminals) and subscriber/network access interface. Some of the deleterious effects that could develop are as follows:

1. Blocked logic states at subscriber/network interface and between subscriber end points.
2. Enlarged and/or more complex data buffering in both subscriber terminals and network access points.
3. Increased traffic loading to network especially erratic peaking packet flow leading to network overloading, possibly to switch blocking.
4. Reduced useful throughput to subscribers.
5. Distress to subscriber software.

The addressing function is of secondary impact in that it essentially adds redundant bit overhead to the subscriber which reduces the effective transmission rate. However, it must be assumed that logic conflicts in addressing are avoided.

The problem of relatively transparent communications to teleprocessing systems is quite complex and varies with different system specifics. The interface and control issues have great impact on individual subscriber hardware configuration and software as well as on system utilization factors and performance. There is a fundamental need to explore the relationships of data integrity, system control, and economic performance between subscribers and a common-user communications network as a function of network design and operation. The objective of a common all-encompassing subscriber/network interface is to allow maximum interoperability\* between the largest number of subscribers. This should be compared to a reduced set of interface standards which produce minimal impact on subscribers\*\* but may incur

---

\* In effect the network performs the function of being a common interface to all its subscribers.

\*\* This situation is conceptually typified by the current use of the telephony plant although lower cost communication networks with quicker response are desirable.

loss of subscriber interconnectivity. The possibilities for a compromise network design between these extremes must be explored. If no single network is sufficiently adequate, a mix of networks may be required and the principal elements of each should be identified.

### C. DATA SWITCHING TECHNIQUES

The development of data switching technology (packet, fast circuit, other) can be expected to have considerable influence on the future evolution of teleprocessing system components and architecture. The discussion here is intended to provide preliminary identification, aggregation, and possible impact on future data networks of switching-technology-related issues.

In other sections of this report, very broad issues were raised in regard to networking in relation to aggregation of users' requirements to network size, scope, topology, capacity, access, cost, control, and standards. In these issues, switching technology plays an important role. This section only discusses the switching element. In particular, "packet" switching is described and contrasted to circuit switching. The reader is assumed to be familiar with the circuit-switching concept and its employment in the telephone plant.

#### 1. Background

Data networks have arisen in the commercial field to meet several classes of service. They have developed in a system-specific manner with very low capability for system cross-operability even within a similar class of service. They have all depended for their communications on the Common Carrier telephone plant.

As a result of the tariff structure and technical characteristics of available terminals, most teleprocessing systems sought better line utilization for their terminal/computer interconnects through the use of concentrators, multiplexers, and "communications front ends" (specialized processor between the computer and the transmission lines). In order to economically broaden connectivity, switching is required. However, as a function of the centralized ADP structure

of most systems currently in operation (Ref. 23), a Star-like topology was adopted (more generally, a Tree topology) wherein switching is implicitly performed by the multiplexer/concentrator in an essentially vertical flow of information between terminals and the central computer facility.

When switching is desired, the normal circuit-switch capability of the telephone plant has proven highly unattractive to the computer community. This derives from the present slow call-setup time (5 to 10 sec) in a dial-up circuit which, for interactive-type teleprocessing, is most disadvantageous. With the long-distance tariff, a circuit-switching line requires the switched path be held for the duration of the call. Since such a call cannot be multiplexed/concentrated, the line utilization is very poor, hence uneconomical. This has encouraged Star-like systems with limited switching between major nodes rather than between terminals.

With the potential for overcoming the deficiencies of circuit switching, the "packet-switch" technology developed by ARPA has been given considerable attention. The packet switch, described in what follows, is capable of several distinctly different functions:

- Provision and control of access/egress to the network
- Packet reassembly
- Addressing
- Concentration of traffic
- Store-and-forward switching with adaptive routing
- Error control
- Code converting.

The ARPA network with the "IMP" packet switch is a particular realization of the above functions. Packet-switched networks can be configured differently (Ref. 11) from that of the ARPA network (e.g., deterministic routing, and hierarchical switching) with different allocation of functions. Thus, it is important to differentiate between the access/egress, multiplex, concentrate functions as well as the address, error control, and routing functions.

Packet switching need not be advantageous for all classes of data transmission, especially ones involving bulk transfer of large data volume over minutes to hours of time (e.g., file transfer). Moreover, for centralized Star networks, the pure switching function requirements are minimal so that present multiplex/concentrator equipment is economic. On the other hand, for interactive quick-response systems with a distributed topology (computer and terminals not connected in a Tree structure), packet switching offers definite advantages. In addition, packet switching can provide adaptive routing which, when taken with a distributed network topology, provides considerably enhanced physical survivability for high-precedence transactions. Of central interest is the development of design guidelines for matching teleprocessing users to a network topology, capacity, and switching. Included should be hybrid packet/circuit switching concepts. To date, no adequate "network" theory appears available for analyzing these issues.

## 2. Packet Switching

Packet switching utilizes the advanced development of small multi-programmed minicomputers to perform the multiplex, subscriber interface, access control, concentrate and route/switch functions. A packet is a piece ("quanta") of information with a beginning (header) containing administrative data (e.g., destination, sequence, precedence, origin, type packet, etc.), a middle containing the data up to a maximum number of bits (e.g., 1000), and an end containing parity check and end bits. Packets are accepted from a subscriber at an access part of a switch and sent on a store-and-forward basis switch-to-switch until arrival at a destination switch which serves the addressee. Incoming packets to the packet switch are placed in arrival queues whereupon logic modules examine the packet header for destination and packet ending for error check. If the packet error check is correct, the logic module places the packet in the appropriate output queue (routing), and informs (by a short packet) the transmitting node from which the original packet was received that it has accepted responsibility for the packet and the transmitting node no longer need

hold the packet in memory. If the parity check were incorrect, a request for packet retransmission would be made. Packet routing is performed adaptively. The packet at a transmitting nodal switch is routed over a transmission line in the direction of its destination. However, with excessive line loading, an alternate node may be selected according to an ordering of next nearest in the direction of the destination.

A packet thus makes its way through the network node by node. In addition to enhanced survivability, an interesting property of adaptive routing is the reduced network delay or flow sensitivity to the detailed traffic structure of each pair of transmitting and receiving subscribers. Network performance depends principally on the sum of individual subscriber traffic. It is clear that the flow is stochastic with node coupling, i.e., events at one node affect those directly connected to it.

There is a substantial amount of software supporting the packet switch. Self-checking and guard programs are required to prevent memory overload and correct or notify failures. If adaptive routing is used (as it is in ARPA network), flow statistics must be exchanged between nodes so that flow routing priority tables can be generated periodically at each node. In addition to routing the transiting packets, there is also software for handling subscriber packets entering and leaving the network. It is here that access control is established and subscriber terminal concentrating and/or multiplexing is performed. Note that "trunk" concentrating/multiplexing also can be performed (e.g., combining several 50-kbps incoming trunk lines to a 224-kbps output line).

The above represents a very simplified description of the nodal packet-switch concept. Considerable descriptive design and details are available\* relative to:

\* A series of Quarterly Technical Reports, "Interface Message Processors for the ARPA Computer Network," generated by Bolt Beranek and Newman, Cambridge, Mass. Frank E. Heart, principal investigator, submitted to ARPA and available from Defense Documentation Center. See Refs. 28, 73, and 74.

- Access/egress
  - (a) packet standard formats
  - (b) protocol between accessing terminals/  
accessed node and accessed node/called node
  - (c) access control, e.g., precedence, preempt
- Concentrating/multiplexing
  - (a) packet stacking in memory or access per above
  - (b) management of input/output memory queues
- Switching/routing
  - (a) routing tables
  - (b) route flow data
  - (c) network control.

This represents an outline of functions performed at a packet-switching node which in turn must be placed within a network topology. Node location and capacity must be interconnected with a grid of transmission lines of suitable capacity. Taken together, the nodes and lines form the packet-switched network.

Returning to the packet node, an extremely important item is the "capacity" of the node, i.e., its ability to process bits per second and packets per second together with the sizing of its memory. The driving factors in sizing a packet node are separable into the access/egress load (terminals, host computers), the subscriber interface characteristics (access line speed/error rate, synchronous/asynchronous, polled, etc.), and the trunk transmission line characteristics (speed/error rate, transmission delay and average/peak load to connected neighboring nodes). Since packets are held in memory until acknowledgment of correct reception by the next node, the summed products of line speed and transmission delay of a node's outgoing trunks play a key role in sizing nodal memory.\* [In this regard,

---

\* Note that should a node bog down, nodes sending to it must be informed so as to reject further traffic destined for the overloaded node; otherwise, propagating overload can occur.

satellite-relayed transmission circuits provide special problems with their long transmission delay (1/4 sec) requiring special node configuration and system software redesign.]

The problem of network topological design, node and line location with the assignment of their capacities admits of idealized analysis based upon the theory of stochastic flow on a graph. Specialization of this theory has been developed and applied to the design of the ARPANET (Ref. 75). Given or postulating a subscriber traffic-flow matrix, a tariff schedule of the Common Carriers, and node costs, a preliminary network can be laid out which attempts to minimize cost for a specialized average or peak-packet transmission time through the network (e.g., 1/2 sec). Such analysis provides the initial setting of the key items of design, such as line and node layout and line speed. (The network topology problem arises for any type of transmission and switching. Graph theoretic flow analysis is a basic mathematical tool useful to this problem. However, specific analytic techniques will depend on the type of network desired.) This then provides the basis for the design of each packet-switching node. The resulting node-specific design, expected performance, and cost can then be reiterated back into the network analysis for further refinement.

To date, the packet-switched ARPANET has been implemented without any hierarchical arrangement of the network topology. However, as the network has grown, it has been realized that regionalizing the nodes (i.e., grouping them into clusters) is advantageous in order to reduce the network housekeeping data flow (overhead) used in computing the adaptive routing tables. Motivated by the routing problem, efforts are under way to examine regionalization for large packet-switched networks. This would impose a hierarchical structure on the network.

The broadened concept of structured hierarchical packet-switched data networks raises many new and fundamental issues relating to (1) hierarchical regional architecture and (2) routing and flow

control within and between regions and interregional interface standards. Specific regionalized network concepts are being advanced in Ref. 28.

Present packet switches are based on and captive to a minicomputer technology which may be obsoleting. Rapid advances in LSI technology and microprocessor development are producing major cost and size reductions in logic hardware which, taken together with progress in memory technology, provide an opportunity to study the advantages of designing packet switches with alternative hardware configurations to the minicomputer approach. The possibility exists of exchanging hardware for software. That is to say, with hardware costs sufficiently reduced, it may become advantageous (Ref. 75) to assign the more repetitive and most often used functional tasks of the packet switch to their own special-purpose ("hard wired") switch components or hardware modules, rather than utilize the present approach of specialized software modules executed on a multiprogrammable general-purpose CPU and memory architecture.

Multilevel security requirements and specialized subscriber interface and control will also be factors influencing switch architecture and design research and development. The packet-switching function, as realized with computer technology, will be required to satisfy multilevel security standards for switching data traffic with mixed security levels. These standards should have a more limited scope than those required for general-purpose (subscriber) computers. The hardware architecture as discussed above as well as intra- and inter-switch logical function (i.e., adaptive routing) will provide important alternatives toward meeting security standards for data switches.

Another related area requiring investigation is the interrelationship of data switch design (including circuit and hybrid concepts as well as packet) with regard to network control, priority preempts, and growth in capacity. These are broad network issues but do have impact on specific architecture and design of the switch and methods of expansion in switching capacity on the traffic load increases over time.

### 3. Circuit Switching

The array of conventional electromechanical circuit switches now operating in the telephony plant are inadequate for providing economical switched service data communications between advanced types of terminals and computers, especially for interactive and inquiry/response type of traffic. The principal deficiency is the excessive amount of time (5-10 sec) taken to set up the call by the several switches traversed in the connection. Also of considerable concern is the occasional (and at some sites) selection of a poor quality circuit which produces too many errors in the received data. This latter effect is of considerable concern to bulk data transmission, such as file transfer and remote job entry, for which circuit switching in theory is economical. These deficiencies in the dial-up network have been the primary motivation for developing leased private data networks based on dedicated point-to-point\* transmission circuits of stated minimum quality.

To date, advanced technology development in circuit switching, ESS #4, has been described in Ref. 67. Since circuit switching is (1) economical for bulk transfer, (2) appears to be more "transparent" to the current ADP communications environment, (3) has a more developed security doctrine, and (4) has better understood network control features, it would seem that there is need for advanced development in circuit switching for data communications. An advanced data-optimized circuit switch should have at least the following features:

1. Fast set-up and take-down time (< 1 sec)
2. Handle large volume of server call requests
3. Switch multiplicity of line speeds
4. Introduce negligible error rate.

Common Carriers burdened with the responsibilities of (1) operating an enormous existing plant, (2) integrating new services with

---

\* No switching provided by the Common Carriers.

that plant in a profitable manner, and (3) maintaining adequate service growth to the principal telephone customers have not been as responsive to the communication needs as desired by the ADP community. However, with the fast growth in data communications and the emergence of the Value Added Networks, it can be expected that there has been study and development effort given to data switches by both Common Carriers and computer-associated manufacturers. With the developing competition in commercial data communications, primarily in the civil sector, and little or no DoD sponsorship of data switches, it is reasonable to conclude that details of new developments in data-switching equipment and especially planning for its introduction to service tend to be tightly held by the developer as a commercial trade secret. Public knowledge would first be revealed by either patent disclosure and/or filing with the FCC for service introduction.

Certainly, the rapid advances in computer component technology useful for developing new packet switches could also be applied to developing radically new circuit switches. Large arrays of replicating digital logic circuits could be utilized for fast digital switching in place of the cross-point components (e.g., ferreeds) of the conventional cross-bar architecture. In addition, multiple micro-processors on a common or paralleled bus structure could be utilized for rapid serving of call set-up requests. (In the presently operating electronic switches a conventional computer architecture is used for serving calls and cross-bar switch control.) From a functional point of view, a new data-oriented fast circuit switch would differ from a new packet switch principally in the deletion of the store-and-forward feature and adaptive routing.

#### 4. Summary

The issues of subscriber aggregation and network regionalization go well beyond switching technology. They nevertheless interact very strongly with choice of switching technique and specific design detail. Economics of scale versus user-unique specialized services versus reliable availability versus system control, and so on, play

a dominant role in setting policy for the evolution of networks and their management. It would seem clear that both packet- and circuit-switching methods or hybrids will be utilized. The need now is for a rational method to aggregate user requirements to determine network(s) topology and select a mix of switching (including control) technique. From this would follow specific switching functional objectives for which R&D in switching technology could be pursued utilizing the rapid advances in LSI and memory technology as well as developments in computer architecture and structured programming. Perhaps of primary concern to DoD teleprocessing applications is switch architecture and design that will meet the multilevel security needs imposed on a network.

The principal advantage of the packet technique resides in its flexible dynamic allocation of trunk and, with adaptive routing, high utilization of overall network transmission capacity on a nearly instantaneous demand basis. If enhanced survivability of communications connectivity is of central importance, packet switching with adaptive routing provides a major advantage. On the other hand, for bulk data transmission such as file transfer and RJE, circuit switching provides more efficient use of the transmission plant areas that have to be addressed--subscriber interface and access control. Packet switching tends to require a more standardized interface while circuit switching allows much more flexibility to the subscriber. Additionally, network flow control with priority preempts is not as well understood with packet switching. Hybrid techniques, which provide a mix of packet- and circuit-switching features, are also possible and desirable.

Network analysis, initially, can only be mathematically idealized. As systems are implemented, the analytical models will have to be further developed (specialized) relative to the details of network specifics. The principal analytical tools used to date are the theory of stochastic flow on graphs (networks) and queueing theory. Cost and performance comparisons between packet- and circuit-switched networks

have many degrees of freedom involving parameter values which will have to be derived from extensive data bases. At this early stage, parameter elements have yet to be properly identified or structured (i.e., interrelated). Consequently, the real data bases necessary to obtain values for the parameters are yet to be generated nor is it clear yet how to generate them. The scope of such comparison effort includes (1) complex paired user requirements matrices (to include "processed" requirements where "like" requirements are aggregated), (2) tariff cost for transmission lines and local loops, (3) nodal (switch and access) performance and costs, (4) kind of network topology, and (5) routing strategy, etc. Often overlooked and very difficult to predict are software costs associated with the system concept.

In a purely technical context (leaving aside issues of regulatory constraints, investment in product lines, proprietary rights and the like), it would appear wise to expect a mix of packet and circuit switching for system implementation in data networks. As previously observed, this strongly relates to the aggregation of user requirements and service. The outstanding problem will be to develop planning capability to (1) design the initial aggregate users and networks or subnetworks for this support, (2) followed by evolutionary growth, i.e., network extendability. A very important issue is the need to provide a framework for correlating the many diverse R&D activities in teleprocessing with regard to a networking strategy. So far, the cost for network R&D would appear to be relatively low.

#### D. NETWORK CONTROL

Underlying much of the discussion in this report has been the problem of system and network control: control between user computer and terminal equipment, control of user access to network, and control within a network. Inadequate control will produce at the

very least congestion within the network. Common-user networks, if they are to operate at economical traffic loading, must have an adequate control system. For teleprocessing systems with dedicated communication facilities, the network control is imbedded within overall system control. To date, control has been treated as an add-on feature to a specified system concept. As such, careful factorization of control tasks is usually not essential. The overall control approach derives from the specific system needs. However, for common-user networks, careful definition and examination of the control tasks, their functional implementation, assignment of responsibility, etc., are essential. Control will impact the balance between and development of dedicated, shared, or common-user networks, and their growth and evaluation as well as strongly influencing which component technologies will dominate.

Inadequate control can result in several types of very undesirable effects on performances. Among these are:

- Delay in service or even logic blocking of ADP/terminal sites and/or network facilities
- Inadequate availability of transmission services
- Intermittent loss of connectivity
- Inadequate throughput
- Unnecessary increase in network capacity and/or ADP site facilities.

In addition to technical problems, there could develop management-oriented difficulties relating to areas of responsibility, such as maintenance, fault allocation and fault correction, priorities of network actions, and developments, etc.

In all of the analyses in the references discussed in Section V-C, control features are explicitly examined or implicitly assumed within the context of the mathematical treatment. Control factors are involved with (1) regard to defining functions and interactions between elements of concept, e.g., system architecture, (2) optimization of system parameters, and (3) choice of operating network

access and switching strategies. Research in network control to date has been pursued within the context of a dedicated system or ARPANET type of common-user network. In either case, a specific type of network architecture and concept of operations are assumed. Consequently, the results tend to specialize according to the type of network assumed.

As seen in Section V-C, the theoretical basis for flow control, a major element of network control, is only in its infancy. Considering the essential role of control, there is an urgent need to support studies in network control. Several principal network modes (shared facilities, piggyback, common user) should be nominated for study. Within each mode, selected examples of likely network architecture and associated operational concept could be studied. For these sets of hypothetical networks, control functions should be carefully factored (i.e., subdivided) and analyzed, including variations on the factoring. As work progresses, review should be pointed toward identifying analytical techniques, results, and principles of operation common to various network types. Hopefully, this would provide, in a bootstrap fashion, characterization and relationship between control and network design. If successful, such results would, in turn, provide needed guidance in formulating system simulation and experimental tests.

#### E. MULTILEVEL SECURITY FOR DATA TRANSMISSION

This section draws attention to and differentiates between the security problems for subscriber host computers as opposed to those for switched data transmission networks. An excellent and detailed review of this problem is provided in Appendix G of Ref. 5. The intent is to outline what are to be the key areas. The security problem area is highlighted here because of its critical importance to DoD applications.

The central current fact is that to date there are no known (i.e., proven) solutions to the multilevel security problem for

multiprogrammed computers, not to speak of computer networks. Furthermore, although there has evolved considerable doctrine for transmission security developed for voice and narrative record communication services, there exists very little experience upon which to base security requirements for interactive switched data communication services. There will be a need to develop new security doctrine suitable for teleprocessing networks.

Security limited to the switched transmission facilities is probably more easily achieved than that needed for time-shared general-purpose host computers. The principal technical unknown is presented by the switching nodes. Current practice can secure the internodal transmission facilities. Since the nodal-switching functions can be made explicit and are limited (in contrast to general-purpose ADP) and since the cost of switch-component processor hardware should not be large, it is reasonable to expect nodal switches to be made secure. Data-switching nodes with security should be realizable with small special-purpose "computers," which, if necessary, can use physical duplication of existing minicomputer technology. Alternatively, specialized new switch architecture based upon microprocessor technology could be employed. The basic uncertainty is not yet having an adequate overall objective or perception for network security standards for which to delineate specific switch requirements.

It is this lack of an overall system perception which is crucial. Although, in principle, the transmission portion of a data network can be made secure, it is not at all clear that:

1. The internetting of subscriber ADP remains secure (the host multilevel security issue).
2. The transmission network will remain economically feasible.
3. The breadth of subscriber interconnectivity can be sustained (e.g., crypto key distribution).

Items 1 and 2 directly relate to determining overall system security as a balance between the transmission facilities and subscriber

facilities. Items 1, 2, and 3 impact heavily on the two major advantages of a common-user switched data transmission network, namely, economies of scale in shared facilities and on-call interconnectivity between infrequently linked subscriber "pairs."

The preceding paragraphs emphasize the security issues limited to data transmission. It clearly interrelates with the subscriber host computer security in terms of doctrine, responsibility and cost. Not immediately obvious, however, is the commensurate time phasing needed between transmission network security and multilevel host computer security. No high-confidence approach has yet been evolved for this latter problem.

#### F. NETWORK INTERCONNECTION

A problem area that can be expected to be of importance in the future will develop from the desirability or necessity to interconnect different networks. This issue has already been raised by the desire to interconnect or interface the SATIN IV network with versions of a projected AUTODIN II network. It should become of considerable importance to be able to interconnect within the DoD certain networks, especially Type I with key Type II networks. A potential role identified for AUTODIN II would be to provide such an interconnection in an on-demand or as-needed basis (a network's network).

Very little is presently known about the problems to be encountered when interconnecting networks. Clearly, factors to be considered are the topological relationships of the points of network interconnects, data interface standards and protocols, partition and interaction of control, assignment of cross-network responsibilities, etc. New classes of problems may be generated in regard to multiple routing, integrity of cross-network messages, and internetwork control stability. A recent paper by Cerf and Kahn (Ref. 76) discusses some of these issues as they relate to interconnecting ARPANET-type networks.

The interconnection of networks must clearly build on the knowledge and experience gained with the use of dedicated, shared, and

AD-A067 281

INSTITUTE FOR DEFENSE ANALYSES ARLINGTON VA SCIENCE A--ETC F/G 9/2  
TELEPROCESSING ISSUES IN THE DEPARTMENT OF DEFENSE.(U)

JUN 75 J M AEIN, T C BARTEE, R A FINKLER DAHC15-73-C-0200  
IDA-S-445 IDA/HQ-74-16813 NL

UNCLASSIFIED

3 OF 3

AD  
A067 281



END  
DATE  
FILMED

6 --79

DDC

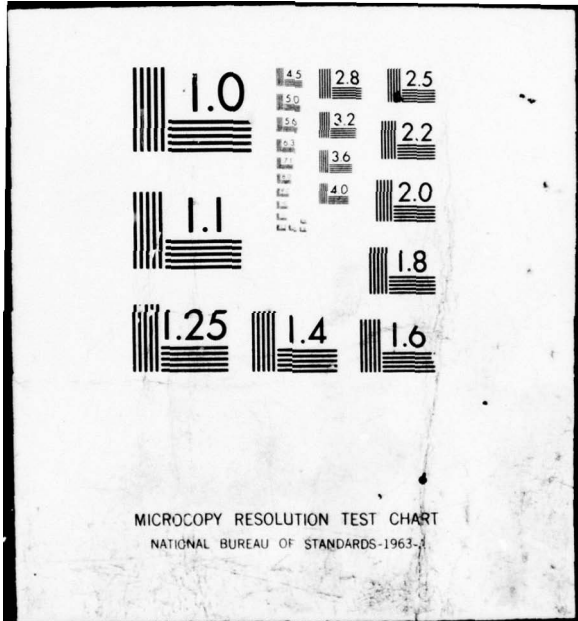

common-user systems. All of the problem areas and development needs discussed in the previous sections for self-contained networks, from requirements through control, are applicable in addition to new classes of problems that will be generated. In addition to seeking convenient data interface standards and maintaining efficient cross-network throughput, attention must also be directed to at least the following:

- Functional interface factors, e.g., formats, protocols, speed of response
- Logic compatibility
- Message integrity and responsibility
- Internetwork control stability
- Fault recovery
- Cross-network security.

A definitive and constructive set of technical standards for network interconnection will be difficult to develop without a more comprehensive DoD requirements policy for network data transfer and/or interoperability.

As pointed out, our knowledge of self-contained networks, let alone interconnected networks, is not adequate. At this early juncture, emphasis can be given to the desirability of interconnection and study effort directed at identifying the interconnection problems generated by their dependence on the specifics of proposed networks.

#### G. COMPUTER SCIENCE

The previous areas of need discussed in this section were oriented toward supporting the development of data communication networks. Certainly, the ability to utilize the teleprocessing opportunities afforded by networks and then, in turn, derive additional guidelines and priorities for network objectives strongly depend on continued or even enhanced R&D in computer science. Those areas of computer science that appear to be most intimately related to developing data networks include the following:

- Privacy and multilevel security between and among users, hardware assets, data bases, and software programs
- Structure and organization of Data Base Management systems for multiuser interactive applications
- Interprocess communication techniques and protocols to support automatic dialogue between disparate machines and software
- Higher order computer language to facilitate all of the above items
- Allocation, control, and evaluation techniques for ADP resource sharing within the context of progress in the above items.

It is not the purpose of this section to elaborate on the above. They are provided in order to restore balance in perspective between R&D for data communication and ADP utilization. An important managerial issue is the need to provide a balanced and coordinated set of R&D efforts while generating much closer interaction and cross-fertilization between the computer science and communication R&D communities than have heretofore existed.

#### H. SUMMARY

This section has identified several teleprocessing problem areas requiring further research effort. The principal focus of the discussion is directed toward subscriber-oriented teleprocessing systems. That is to say, teleprocessing systems, whether dedicated to a closed community of users or open to general users, adopt, as a fundamental design philosophy, the interconnection of multiple users on a subscriber basis.

The areas identified for further effort are:

1. Requirements formulation, activity modeling, and system evaluation
2. Data interface standards
3. Data switching techniques
4. Network control
5. Network interconnection

6. Multilevel security for data transmission
7. Computer science.

These areas are all highly interrelated in the design of any specific system. Of especial significance to DoD is the multilevel security problem as it pertains to both data transmission (area 5) and to subscriber host computers (area 7).

A general requirements formulation process is needed not only to design and evaluate new systems but is also of importance to provide upper management with more uniform and useful reports of utilization and status of systems to make informed decisions as to system upgrade, cross-connection, replacement, etc. Data interface standards are essential for achieving wide subscriber interconnection and economies of scale in ADP services as well as achieving essential command and control information exchange. A critical issue are those standards which involve logic interactions (start/stop, error recovery, identification) and a careful delineation of subscriber-to-subscriber control as opposed to subscriber-to-transmission network control, and control within the transmission network. Previous efforts have attempted to standardize on data formats and structure. Poor data standards lead to inefficiencies\*; inadequate logic standards can deny use altogether. Data-switching technology (packet, fast circuit, and hybrid) will have a strong role in regard to standards and, perhaps even more importantly to DoD, in regard to multilevel security. New microprocessor and solid-state memory technology allows for developing data switches with a shift in emphasis from software architecture to new specialized hardware and firmware configuration. For common-user networks, flow and access control is an essential need to equitably provide transmission capacity to the subscribers. For DoD application, the need for control methods is even more pressing in order to provide priority service to the more critical military data. There is currently an inadequate understanding of this problem area. Control methods will strongly interrelate to data interface

---

\*The economic implications of which can preclude usage.

standards, switching architecture, and the multilevel security mechanization.

Multilevel security is an essential element for DoD teleprocessing systems. There is, to date, no known method to provide adequate security to teleprocessing systems. In subscriber-oriented systems, it is important to differentiate between subscriber host/computer security and security in the switched data transmission facilities. Since switching nodes utilize limited and specific ADP functions, which can be hardware compartmented and housed in secure facilities, it is reasonable to expect that switched-data transmission security will be more easily or earlier achieved than that for host computers. A basic issue is the perspective between transmission security as opposed to subscriber security. It is obviously not sufficient to have one without the other or to overinvest in achieving one at the expense of the other. Even more fundamental is the likelihood that the security problem will not neatly factor into subscriber and transmission security areas. Taken separately, security may be achieved for transmission and host sites but when connected in a network weaknesses may present themselves. Even though subscriber computers were to be secured individually, it must be verified that as a net, security is not compromised. It seems certain that new security doctrine will have to be evolved. Due to the fundamentally new features (technical, operational, and organizational) of data internetting, a proper management forum and plan are needed to initiate data security measures.

It can be expected that future teleprocessing networks will develop a need to interconnect at least selectively (at gateway locations) or itinerantly in time or both (e.g., a network's network). This is an issue for the future but one which current system planning should take cognizance. Very little is known about this subject. Areas of additional technical complexity beyond those mentioned for independent networks include: internetwork functional interface, logic compatibility, message responsibility, control stability, fault recovery, and security.

The previous paragraphs of this summary principally address the network transmission and interconnection functions. Of perhaps even greater significance are computer-science-oriented problems, especially as the (as yet unknown) fourth-generation ADP context is manifested. Areas of computer science that are of especial importance to DoD include:

- Multilevel security at and between subscriber facilities
- Data base management systems for multiuser interactive access
- Interprocess (software) communications techniques between disparate machines and facilities.

If current and future R&D activities are left uncoordinated, any trend toward proliferation of teleprocessing systems and networks would remain unchecked.

## VIII. DOD DEVELOPMENTAL SYSTEMS AND STANDARDS

The DoD has in development a number of computer-to-computer communications systems. While there are differences in the functions performed by these systems, they have many desirable features in common including reliability, survivability, security, and responsiveness. There is a clear requirement to interconnect these systems and to transfer data from system to system, and many of the interoperability difficulties that arise are due to the independent development of the systems. A basic question that arises is whether individual systems indeed have such unique requirements that common protocols, procedures, and programs cannot be used in and between the various networks.

There is and will continue to be a need for high-level examination of the systems under development, first to ensure that intersystem standards, operating procedures, etc. are properly established and, second, that the resources and technology which are developed are shared among the system programs. The considerations and problems discussed in the following sections concerning DoD teleprocessing systems now in development indicate a need for immediate action in two areas: (1) the establishment of several DoD standards for protocols for teleprocessing systems, and (2) the development of a set of highly modular standard programs for use throughout the DoD. These should include service programs (e.g., data base management systems such as NIPS, WWDMS, and FMIS) and applications programs (e.g., FORSTAT AND JOPS).

The establishment of DoD standards would have two immediately ascertainable salutary effects. First, they would facilitate the interoperability of such systems as SATIN IV, the AABNCP, and the WWMCCS computers at the ANMCC and NMCSSC, and permit these development

programs to continue with less chance of future complications or problems. Second, if care is taken to ensure that the standards developed are generally compatible with what appear to be the developing industry-wide standards [for instance, the ANSI Advanced Data Communication Control Procedure (ADCCP) based on the IBM-proposed Synchronous Data Link Control (SDLC)], then compatibility with commercial gear, such as terminals, would be ensured. In addition, it appears sensible for DoD to work closely with ANSI to establish standards so that DoD-designed systems will be immediately compatible with commercially designed systems which implement the ANSI standards.

The development and implementation of highly modular standard service and application programs are called for by similar reasoning. Given that a user can establish a communication link with a given computer, unless he knows and understands the standards and use of service programs (such as the data base management system's query language or how to use application programs such as FORSTAT), he still cannot effectively obtain information or interact with these programs. Teleprocessing requires widespread data and information standardization for successful interchanges at all levels.

#### A. SYSTEM STANDARDS

The DoD faces a large investment in software with the multiplicity of different systems now being developed. Only through industrywide standards can DoD economically ensure that major systems procured from different manufacturers will be able to communicate through common-user or special dedicated communication systems. Many of the problems that are now appearing (and will increase in the future) can be eliminated or alleviated by proper action at this time. Program delays and additional costs that have appeared in early phases of programs now in progress could increase if standards are not developed.

The DoD has been a leader in developing standards and, in the computer area in particular, the DoD has been responsible for developing standards that have become widely used in industry. For example, the computer language COBOL is now the most used language in industry as well as in the DoD, and was developed with the active participation

and drive of the DoD. Standards, such as the Mil 806, which became the ANSI standard for graphic symbols for computers, were developed by the DoD adopting and improving an industry standard not in widespread use. In this case, the enforcement of the DoD standard led to an almost universal industry adoption. A similar situation exists regarding the computer language FORTRAN, where DoD and Government actions have led to widespread use of a particular version of an already existing language.

In the area of teleprocessing, the DoD has already established a technology base that can fortunately be used to develop standards. This base includes the ARPA funded and directed ARPANET program, which is the first large interactive teleprocessing network that includes diverse computers and terminals. The ARPANET is an ongoing development but already provides, in one form or another, many of the features generally considered to be desirable in teleprocessing systems. The DoD also has several teleprocessing systems in various stages of development and a prototype system, the FWIN, specifically designed as a support vehicle for further studies.

## B. TELEPROCESSING SYSTEMS CAPABILITIES

In order to develop a background for discussing teleprocessing issues, some of the capabilities that can be provided by teleprocessing systems are presented. Different systems have differing requirements, but the following list encompasses most of the capabilities commonly specified.

### 1. Terminal Servicing--Interactive Systems

An important capability that can be provided by an intercomputer communication system is that of servicing terminals at local and remote computers. For example, an analyst at a terminal in the Pentagon might wish to query a data base located at the MAC WWMCCS complex or at REDCOM in order to develop and cost contingency troop movement plans. This task may well include the running of programs located at the remote computer so that the analyst may have not only basic raw data, but also be able to derive statistics or accumulated data

using programs located on the remote host. When a computer terminal system is designed so that the user of the terminal is able to query the data base or operate a program, examine the results and then ask for further information from the computer over a reasonably short time period, the system is said to be interactive.

In order for computer-serviced interactive terminal systems to be most effective, it is necessary to reduce the response time so the delays incurred by the communication system are on the order of seconds.

## 2. Data Base File Transfers

A widely needed capability for DoD intercomputer networks includes the ability to transfer files from one computer to another. An example of a file transfer is the periodic updating of the FORSTAT file in the NMCSSC by moving the updated file change information from the ANMCC. In this case, the ANMCC computers perform the actual FORSTAT file updating and then transmit the file update information, which is effectively a file, to the NMCSSC using a 50-kilobit line between the WWMCCS computers at these sites.

The ability to transfer files from computer to computer gives a computer network the ability to store duplicate files at several locations, thus providing reliability and survivability in case of the loss of one or more computers or of the loss of communications from the decision maker to a computer which contains required information. Sometimes cost savings can be effected by sending file or change data from heavily loaded computers to computers that are less heavily loaded where the files may be processed. This is called load leveling. Sometimes small computers can utilize larger computers connected by communication links to perform jobs at a cost saving since larger systems tend to provide computations at a lower cost. Passing jobs around a network is called resource sharing. In any case, file transfer is an important function of computer networks, particularly in command and control systems.

### 3. Remote Job Entry

An example of remote job entry is the use of a card reader and printer at a site which is remote from the computer. In this case, the user's job can be read by the local card reader and data (and often programs) transferred to the remote computer over the communications system. The remote computer runs the job in its batch-processing mode, delivering the results to the printer through the communications network.

A remote job entry facility gives the user the ability to use a large computer complex that is located some distance from his relatively inexpensive card reader and printer.

### 4. Teleconferencing

Teleconferencing is the use of a telecommunications system to interconnect terminals which are physically separated so that entries at one terminal are immediately available in printed form at the other terminals. Computer networks, such as ARPANET, provide a teleconferencing facility (as well as an "electronic mail" system) that can eliminate delays through local communication centers. Using teleconferencing, it would be possible for a terminal in the NMCC to be connected to terminals at the command centers of MAC and REDCOM. In a command and control environment, this provides decision makers and their staffs with an important capability, rapid record communications, as an easily provided offshoot of the intercomputer communications network.

### C. TELEPROCESSING SYSTEM PROTOCOLS

When computers, terminals, sensor systems, remote job entry devices (card readers, printers, etc.) or other digital devices are interconnected, procedures must be designed so the devices can communicate effectively. These procedures can be quite simple or very elaborate, depending on the complexity of the information transfer required. A complete set of procedures for interdigital-device communication is commonly referred to as a protocol. When

computers are interconnected using a communications network, several different protocols may be required.

As an example, in the ARPANET system, the data processing computers are called Hosts, and the communications network basically consists of a set of communication computers called IMPs, which are interconnected using leased lines. The procedure a computer follows when sending a message to or receiving a message from another computer via the ARPANET entails a Host-IMP protocol (this is basically a computer-communications network protocol). The IMP communication computers then communicate using an IMP-IMP protocol. Host computers also have a Host-Host protocol to facilitate their information transfers. Because these protocols are distinct, they are said to be layered.

Data to be transmitted in the ARPANET are broken into segments, each less than some maximal length, and each segment is referred to as a packet. As a part of the protocol, packets are generally preceded by a leader telling, for instance, where the packet is to be sent, how long the packet or complete message is, etc. A trailer at the end contains check bits for error detection, some padding if necessary, etc.

The protocols in the ARPANET (and in most presently planned systems) are implemented by means of computer programs. In the ARPANET, for instance, computer programs in each IMP implement the IMP-IMP protocol and the IMP part of the Host-IMP protocol. Since the programs in a general-purpose computer can be changed, the protocols can also be changed in a given system, and the ARPANET protocols have been periodically updated. This is not without cost, of course, and the costs of programming (or reprogramming) protocols are about the same as other programming costs. It should be noted that while the ARPANET from a technology viewpoint provides an intercommunication system design strategy that can be used to satisfy most basic system requirements, its protocols were a pioneering effort and much has been learned from its operation. As a result, it is

possible to improve and enlarge on these protocols and to accommodate other DoD requirements such as network security.

When different communications systems use different protocols, the user of one system cannot immediately connect to another system without reprogramming his communications system protocol. The reprogramming need not be at all levels, however. For example, two computers using the ARPANET and having a usable Host-Host protocol would have to change their Host-IMP (computer-to-communications systems) protocol to use the CYCLADES network (in France) but could continue to use the same Host-Host protocol because of the layering.

A common set of protocols is of primary importance in the implementation of planned DoD systems. Particular problems have arisen and will continue to arise from such systems as SATIN IV, NEACP, the WWMCCS computers, the IDN communications systems and others, each have differing protocols. While a difference in protocols can essentially be accommodated by developing a set of computer programs that will convert from one protocol to another and then by adding computers at appropriate points in the network, this solution is costly and increases the risk of delays and cost overruns during system implementation.

Examples of problems that can arise when differing protocols exist in different DoD systems are given in following sections. A description of several systems now in development is included to clarify the problem areas.

An important element in DoD systems that is not present in most conventional systems concerns mobility. Terminals may be located on aircraft, ships, submarines or other mobile units and as a result may cross the boundaries of DoD systems. (It is not unthinkable, for instance, that the AABNCP in its NEACP role might find itself over Omaha.) Moving from one system to another should not limit communications systems' usability. An excellent way to provide for unexpected transitions is to have standard protocols.

D. PWIN--THE DOD EXPERIMENTAL TELEPROCESSING SYSTEM

The plans for the Prototype WWMCCS Intercomputer Network (PWIN) (briefly discussed in Section III-B) calls for a communications subnet consisting of three communication computers (IMPs) interconnecting the three WWMCCS computers located at JTSA, NMCSSC, and CINCLANT in Norfolk, Virginia (Fig. 31). The IMPs in the PWIN system are connected by 50-kilobit full-duplex leased lines. The IMPs were delivered by Bolt Beranek and Newman. Each IMP consists of a Honeywell 316 computer plus some additional interface circuitry and electronics. An additional Honeywell 316 computer is to be located at JTSA as a network control center to monitor and control the communications subnetwork.

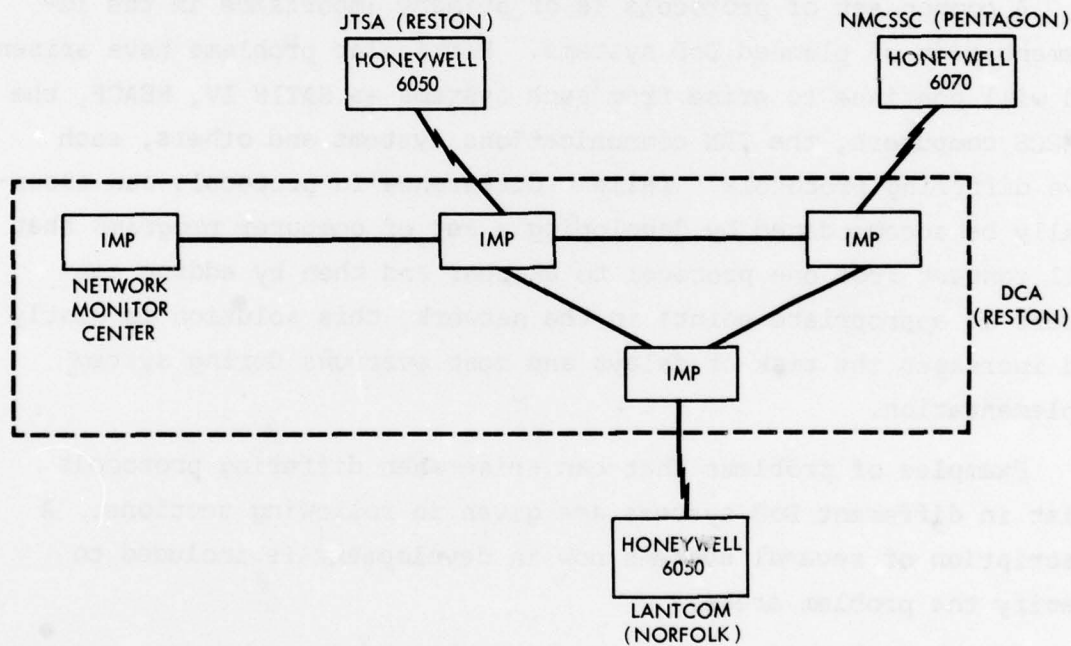

2-11-75-3

FIGURE 31. Prototype WWMCCS Intercomputer Network

The basic ideas and communication techniques used in the PWIN system are derived from those developed for ARPANET. In both ARPANET and PWIN, digital communications is provided by breaking the stream of bits to be transmitted to 1000-bit (or smaller) packets for transmission through the communications subnet. Each packet is prefaced by a short sequence of bits called a leader, which contains such information as

the destination of the packet, the source of the data, and some administrative information used by the communications subnet. A set of binary digits is added at the end of each packet in order to detect errors when they occur in the communications subnet. Erroneous packets are then retransmitted.

The IMPs function in the communication subnet as store-and-forward communications computers. In order to transmit data from one host computer to another, the host computer generates packets from its data and delivers the individual packets to the IMP to which it is connected. Each packet is then stored in the IMP, which determines which leased line will be used to transmit the packet. This decision is made by means of a routing algorithm.

IMPs have the ability to store a number of packets, queueing the packets and then delivering them to the selected communications lines. The routing strategy is intended to minimize the terminal responses for interactive systems. In the original ARPANET and FWIN routing strategies, great emphasis was placed on servicing terminals so that terminal users would have responses from remotely located computers in relatively short time (less than a second). Later versions of the routing strategy have attempted to increase the throughput or total effective speed that can be attained from host to host when a large volume of data must be transmitted without any serious degradation in the response time for the interactive terminal user.

Perhaps the outstanding success of the ARPANET has been in the ability of this network, which comprises a large number of different types of computers at remote sites, to provide good service to (1) the interactive terminal user, (2) the report or message category of user, and (3) the bulk data or file transfer category of user. The ARPANET protocol, in particular the leader and trailer design, is such that relatively low overhead, somewhere from 13 to 17 percent in the tests so far, has been obtained.

While the basic protocols in ARPANET and FWIN are the Host-Host, Host-IMP, and IMP-IMP protocols, there are a number of other protocols that have been developed by ARPA for use in this network. These include

the protocols for remote job entry, file transfer, and teleconferencing. Figure 32 provides a conceptual view of some of these protocols and how they have been layered. It is important to notice that communicating devices or processes must use the same protocols within a given computer-computer network and to realize, also, that these protocols are primarily provided by computer programs that implement the protocols in the Host computers and communication processors.

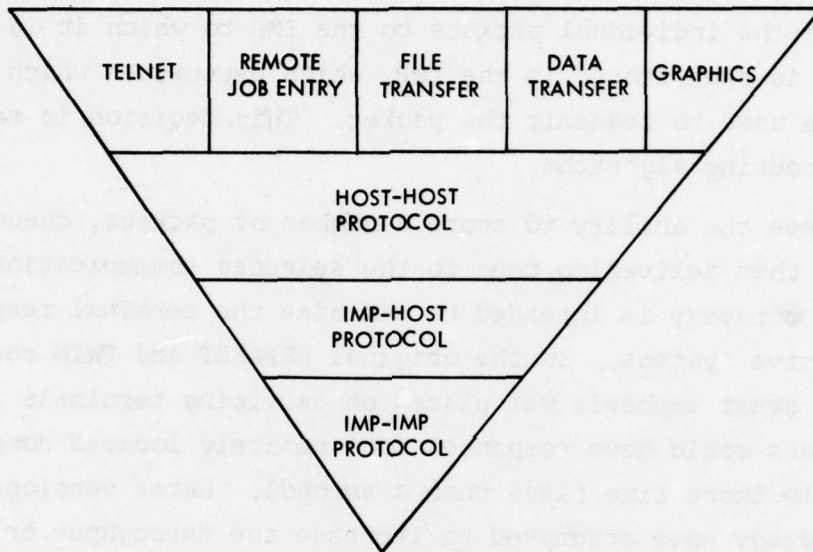

2-11-75-4

FIGURE 32. Layering of Protocols

#### E. THE ANMCC-NMCSSC INTERCOMPUTER LINK

In order to clarify some of the issues that arise when inter-computer networks are implemented by the DoD, two specific examples will be given in this and the following section. The first example concerns computer-to-computer links between the ANMCC and the NMCSSC. Figure 33 shows the original configuration. The two links shown between the ANMCC and the NMCSSC were furnished as part of the Defense Communications Network. At that time, the ANMCC contained an IBM 360/50 and the NMCSSC an IBM 365/65. Communications between these computers were provided by means of two IBM communication processors (both IBM 2701s), two Bell 301 data modems, and a 40.8-kbps leased communications line. This is a widely used commercial configuration:

the IBM 2701 is a standard IBM interface computing device and the Bell modems and leased lines are standard AT&T equipment. The second communications link shown is between a Honeywell system's 700 remote-job-entry terminal in the NMCSSC connected through data modems and a 2400-bps line to a Honeywell 355/Honeywell 6060 combination at the ANMCC. The 355 is the standard Honeywell interface computer that is used to connect terminals and remote-job-entry devices to the Honeywell 6000 series computers, which have been procured for the WWMCCS. Both of these data links are, therefore, standard commercial configurations.

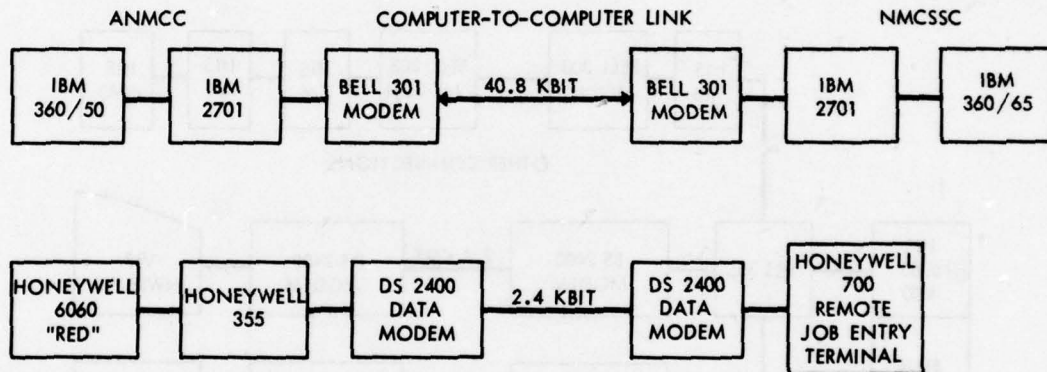

2-11-75-5

FIGURE 33. ANMCC to NMCSSC Intercomputer Link

An example of the use of the IBM 360-to-360 link in daily operation and one of the primary reasons for the 40.8-kilobit line (as opposed to a more conventional slower line) concerns the running of the FORSTAT update programs. The ANMCC and the NMCSSC contain copies of the FORSTAT programs; however, on normal workdays the NMCSSC computers are more heavily loaded than those at the ANMCC and so the normal FORSTAT updates are performed on the ANMCC computer and the processed file changes are transferred to the IBM computer in the NMCSSC using the 40.8-kilobit line. This transfer of data, because of the large volume of data, requires nearly two hours.

Because of the presence of the WWMCCS computers in the ANMCC and NMCSSC, it was decided to remove the IBM machines from these locations and transfer their functions to the Honeywell computers. To this end, the FORSTAT programs were rewritten in COBOL so they could be run on the Honeywell computers. Also, it was necessary to replace the IBM computer-to-computer link with a Honeywell WWMCCS computer-to-computer link. Original plans called for the configuration shown in Fig. 34. The figure shows the arrangement for remote job entry and terminal connections from the NMCSSC to the ANMCC using data modems and an HIS 355. (These again are standard commercial configurations and do not involve computer-to-computer data transfer or communication.)

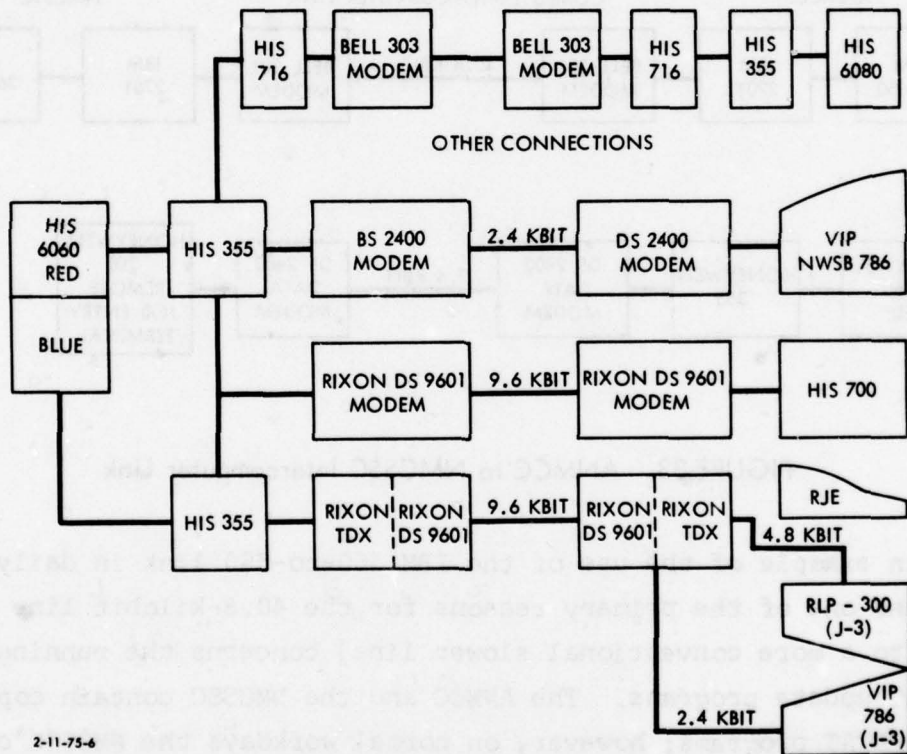

2-11-75-6

FIGURE 34. Planned ANMCC-to-NMCSSC Intercomputer Link

The computer-to-computer links involve two interface communications computers for each 6000 series computer because Honeywell's operating system and network software require either the use of an HIS 355 or very considerable reprogramming. The Honeywell HIS 716,

which is a Honeywell minicomputer, then has to be used to perform the computer network functions. The programs for this particular computer are to be derived from the ARPANET programs which are used in FWIN; thus the protocols in this particular system will be essentially ARPA protocols. As a result, it is doubtful if the throughput will be adequate for FORSTAT transfer at present rates. Further, because of delays in the delivery of the software for these particular computers, an interim system consisting of a direct link between the two Honeywell 355s in the system has been scheduled. In order to effect this particular connection, Honeywell was given a contract to modify the existing Honeywell 355 software to make computer-to-computer transfer of data possible, using only the 355s. This interim system, however, is supposed to be replaced as soon as the necessary software for the Honeywell 716s is completed. From a protocol and network viewpoint, this link would then function as a segment of the FWIN network. It should be noted, however, that this is not a part of the FWIN configuration. Further, because of the low file transfer rate in ARPANET and FWIN (which is primarily due to the RFNM and message assembly procedure in the protocols), the planned lines will probably not be able to carry the present 40-kbit file transfer load (10 to 15k are ARPANET rates). Nevertheless, we will use this planned configuration in our description.

#### F. THE AABNCP-SATIN IV/ANMCC INTERCOMPUTER LINK

An excellent example of the problems that can be caused by different protocols arises in the use of the Advanced Airborne Command Post in its two roles: one as the NEACP, and the other in its function for SAC. The seven AABNCP aircraft are to have standard data processing and communications equipment. In its NEACP role, the ADP requirements include obtaining data for attack assessment, force monitoring, and SIOP following/execution. The data required are to be obtained largely from ground-based WWMCCS computers, and the NEACP is to interface directly with the Honeywell computers in the ANMCC.

Since the AABNCP also functions in a SAC role, the interface was originally specified to use the SATIN IV protocol. There has been

considerable opposition to this, however, because the original SATIN IV protocols used long leaders and headers, and the NEACP requirements call for an interactive system response time that would be hampered by the complexity of the SATIN IV protocols. The ANMCC Honeywell computers also currently use a Honeywell protocol, and will have a common WWMCCS protocol in the near future and a PWIN/ARPANET programmed protocol for the ANMCC-NMCSSC link. Inclusion of the SATIN IV protocol would require preparing still another program for that protocol. Further, using the SATIN IV protocol, the NEACP could only communicate directly with the ANMCC computers and ANMCC computers would have to be used to obtain data from other WWMCCS computers. The NEACP terminal could not enter the WWMCCS inter-computer network directly because of the protocol differences, despite the fact that the existing link from the ANMCC to the NMCSSC uses communications computers identical to the interface computer used for the NEACP to ANMCC link.

One of the proposals that has been made to alleviate this problem is to consider the NEACP as a terminal to the WWMCCS computer at the ANMCC, and to use existing Honeywell programs and protocols suitably modified. This plan has been considered on both a long- and short-term basis. The problem that arises is that the NEACP would not have the proper WWMCCS protocol, and that Honeywell's existing systems have no provision for precedence and, more important, little provision for security.

To clarify this proposal and show the sort of complication that arises from mixed protocols, Fig. 35 shows the proposed arrangement in block diagram form. In Honeywell's terminology, each HIS 355 functions as a Front-end Network Processor (FNP) and each HIS 716 (700 series) machine functions as a Remote Network Processor (RNP). The proposal suggests the HIS 355 programs can be used in their present form and that the AABNCP CPE be programmed to use the Honeywell protocols so that the AABNCP CPE appears as a terminal to the HIS 716 in Honeywell's standard 716-355-6000 series configuration.

An HIS 716 would be connected (on the ground) to an HIS 355 that is connected to the WWMCCS computer at the ANMCC. This computer would

interface with the AABNCP as shown in Fig. 35. The HIS 716 is required at this point because it will contain the principal data base interrogated by the AABNCP. A preformatted query language would be used so that the AABNCP (NEACP) would address most of its queries to the data base in this computer. This data base would be updated from the WWMCCS computer in the ANMCC.

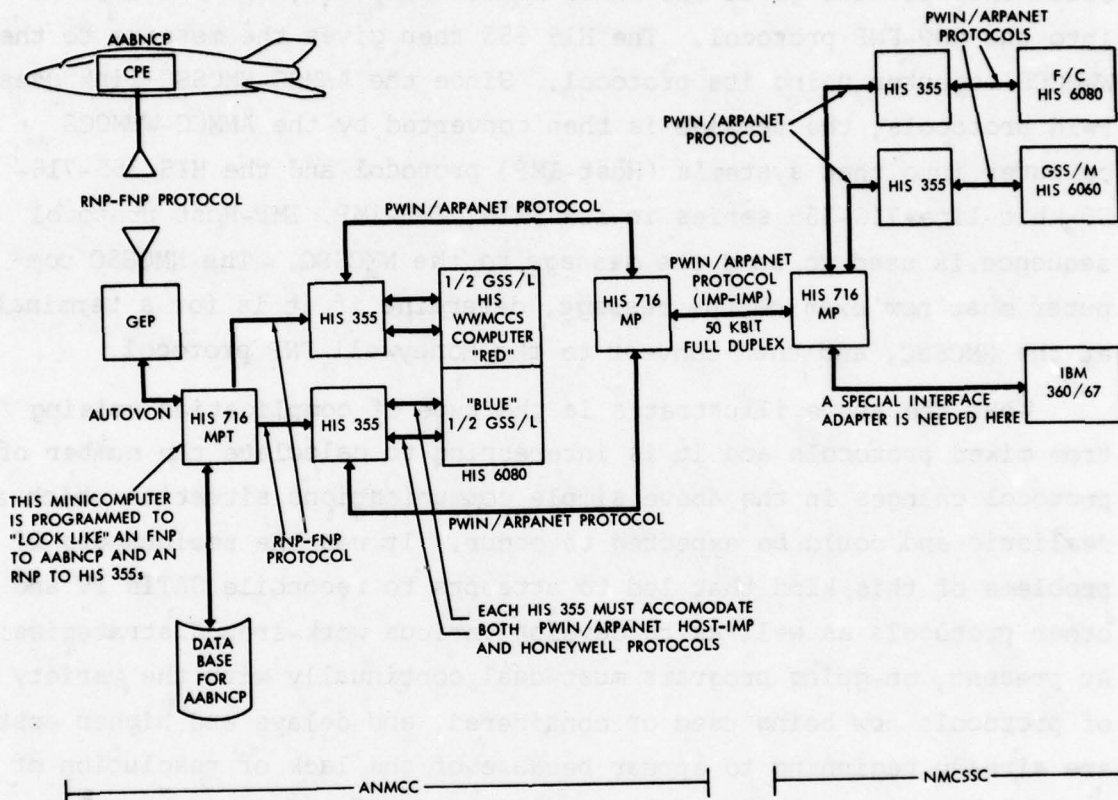

FIGURE 35. Flow of Protocols in Proposed Systems

In order for the AABNCP to have the ability to use the WWMCCS computer directly as well as the data base in the HIS 716, programs would be written so that this HIS 716 could interface the AABNCP and the 355-WWMCCS computer configuration with ANMCC. Thus, the protocol in this HIS 716 will cause the computer to "look like" an FNP to the AABNCP and an RNP to the HIS 355 connected to the WWMCCS computer.

Now, let us consider the sequence if a terminal on the AABNCP wishes to send a message to a terminal in the NMCSSC. (The reverse sequence would be required to transmit from the NMCSSC to the AABNCP.)

First, the AABNCP terminal's output is sent by the airborne communications processing element (CPE), in the Honeywell RNP protocol, to the ground-entry point and is relayed on AUTOVON lines to the HIS 716 in the ANMCC. The HIS 716 now examines the received message, determines it must go to the ANMCC-WWMCCS computer, and converts it into the RNP-FNP protocol. The HIS 355 then gives the message to the WWMCCS computer using its protocol. Since the ANMCC-NMCSSC link uses FWIN protocols, the message is then converted by the ANMCC-WWMCCS computer into that system's (Host-IMP) protocol and the HIS 355-716-50-kbit-line-716-355 series in its FWIN, IMP-IMP, IMP-Host protocol sequence is used to send the message to the NMCSSC. The NMCSSC computer must now examine the message, determine if it is for a terminal at the NMCSSC, and then convert to the Honeywell FNP protocol.

What the above illustrates is the type of complication arising from mixed protocols and it is interesting to calculate the number of protocol changes in the above simple communications situation which are realistic and could be expected to occur. It was the seriousness of problems of this kind that led to attempts to reconcile SATIN IV and other protocols as well as to develop various work-around strategies. At present, on-going programs must deal continually with the variety of protocols now being used or considered, and delays and higher costs are already beginning to appear because of the lack of resolution of some of the protocol problems. Immediate action needs to be taken to alleviate intersystem protocol problems in the future among systems which must regularly interface.

The need for compatibility of the SATIN IV protocols points out the advantages of a common protocol for some DoD users. If the AABNCP must interface with the WWMCCS computers in its NEACP function and also with SATIN IV in its SAC Airborne Command Post function and if SATIN IV and the WWMCCS use different protocols, then the mismatch of protocols would entail extra programming for computers which have been planned--at best--or both additional computers and extra programming in the worst case.

While all of the above interface-protocol problems can be solved singly as they arise, there is always a cost involved. Also, it is difficult to predict every case that might arise in the future, and the adoption of common protocols now will give future flexibility. The existence of DoD standards in the computer communications areas would alleviate or eliminate many of the above problems in systems design. The DoD now has sufficient experience and an adequate technology base to begin protocol standard design, and immediate steps need to be taken.

#### G. DEVELOPMENT OF STANDARD SOFTWARE PACKAGES

The costs of computer software have been sufficiently high, and the delays in software production sufficiently long in both industry and DoD that we frequently hear the phrase "the software problem." There are, in fact, a number of software problems (or at least a number of reasons for the software problem). One effective measure in alleviating this problem lies in identifying system programs and applications programs that can be used in a number of different systems and to develop these programs only once.

When various users or system developers are presented with the idea of sharing a commonly produced program or set of programs, a frequently heard response is that the program(s) will not be "custom made" or tailored to the specific requirements of a given system. Fortunately, good software development concerns can now provide programs that are highly modular and in many cases can custom-fit a package of the modules to particular systems. There are already a number of instances where large modular programs have been developed and widely used. In some cases, programs adapted to the demands of a given system can dynamically adjust their operation to other system requirements. In other cases, sets of modules are compiled together to fit the needs of a particular system. (This is often the case with commercial operating systems where the system operator can "custom make" his operating system to his needs and feeling for system economics.)

For teleprocessing systems, the need for standard programs, which exist and are operated at various sites, becomes even more important. The user of a teleprocessing system does not need the extra complication of having to know how to operate different programs that exist in various places in order to obtain the data he desires. The system user should not have to be multilingual to interrogate similar files in different locations. Further, if programs are to interact or to access data at different locations, extensive translators or reformatting programs should not be required. For economy of operation and to minimize development risk, applications and systems programs should be jointly developed whenever possible.

The administration of the development of standard system program packages involves finding the areas where such programs are needed, and then seeing that the programs produced meet all the systems requirements.

The arguments against standard software packages are pretty much the same as the original arguments against standard versions of such languages as FORTRAN or COBOL which are again not specifically made for any particular application. In the long run, however, these standards have proven cost-effective and similar gains should result from developing standard software packages.

#### 1. Data Base Management Systems

As an example of an area where standard software packages and procedures can yield a large savings and also greatly facilitate teleprocessing system development, we now examine Data Base Management systems.

A major part of the data processing in the DoD involves large files of data. Common operations involve (1) searching these files for particular items or classes of items, (2) updating the files, and (3) deriving statistical data from computer-directed searches of the files. When a set of files is organized and operated together, it is (collectively) referred to as a data base.

In order to efficiently maintain and operate large data bases, programs have been developed called Data Base Management Systems (DBMSs). These programs are in wide commercial use and most major computer manufacturers have Data Base Management systems available. The market for such systems is sufficiently large that a number of commercial software firms also provide such systems on either lease or purchase arrangements.

Data Base Management systems have been used by the DoD in the past and several such systems now exist or are in development. These include NIPS, the DBMS originally used in FORSTAT; WWDMS, the Honeywell WWMCCS system; and FMIS, a SAC system.

Different Data Base Management systems have different features and characteristics. Basically, a Data Base Management system provides users (1) a language to describe the data in the files and to name the files and data bases; (2) the ability to originate and to maintain or update the files either on line through terminals, or by using cards or other input media; (3) a language and facility for data retrieval, including the ability to describe collections of data using logical operators (list all ships in the destroyer class and with age greater than 20 years); and (4) some report-generation features are often included to facilitate the preparation and formatting of reports generated from data in the data base.

Some Data Base Management systems allow users to program using COBOL or some other standard language and use the DBM to handle all the data base handling details; other DBMS provide all the programming and other languages internally (NIPS, for instance, is in this category).

As can be surmised, in a teleprocessing environment there is a considerable advantage in having similar data structured in the same way at various locations in the network. This permits more efficient system operation, reducing the need for expensive translator or re-formatting programs, and also facilitates in the moving of personnel from site to site without extensive retraining, etc. Similarly, having a standard query language reduces the need for "multi-lingual" specialists in obtaining data retrievals. In some operational situations this would be very important.

## 2. Standard Applications Programs

A good example of a large program developed by the DoD is that used by the Force Status and Identity Information Processing System (FORSTAT). This system provides current information on the status and location of military resources as required by the JCS and National Command Authorities. Management of the FORSTAT is provided by the Status of Forces Branch of the Operations Directorate.

The FORSTAT reporting structure was developed by the Data Processing Division of the Operations Directorate of the Joint Chiefs of Staff, and is a part of the Joint Reporting Structure. The FORSTAT Data Processing System was developed by the National Military Command System Support Center which also maintains and operates the system. Two characteristics of the FORSTAT programs are of particular interest: (1) identical FORSTAT programs are located and operated at several locations in the Worldwide Military Command and Control System, and (2) the original FORSTAT programs were developed using a Data Base Management system called NIPS.

The FORSTAT programs are operated in four different modes, each corresponding to a different operational level (JCS, Service, CINC, and Major Command). While different capabilities are available at each operational level, the data base maintenance is identical in all four modes. At present the operational modes and users are:

- |                       |                                  |
|-----------------------|----------------------------------|
| 1. JCS Mode           | JCS<br>ANMCC                     |
| 2. Service Mode       | Air Force<br>Marine Corps        |
| 3. CINC Mode          | CINCEUR<br>CINCPAC               |
| 4. Major Command Mode | AREUR<br>USAFE<br>PACAF<br>ARPAC |

There are several advantages in having the same programs at a number of installations. Some of the more obvious advantages accrue

from the fact that system operators can be readily transferred between these locations with little additional training required; the original programs were only prepared once, not at each site; training and documentation need only be prepared once, program corrections and updates are facilitated, etc.

In a teleprocessing environment where updating of files takes place using communication links between computers, there are several additional advantages to having common programs at the various sites. Since the data are maintained in identical formats, file transfers and updates are greatly facilitated and can be made on-line without format conversions. Another not so obvious advantage lies in the fact that a terminal user can interrogate files at various locations using the same query language. If the programs were not standard at the sites, either a user would have to learn several languages in order to use the different systems, or language translators would have to be developed to translate the users' requests at each different site. (This problem could be alleviated by use of a common Data Base Management system at the different sites.)

The original FORSTAT programs were developed using a DoD-sponsored Data Base Management system which has seen considerable usage called the National Military Command System Information Processing System 360 Formated File System (NIPS). This system was developed by the National Military Command System Support Center for the IBM 360/370 series of computers (IBM provided the programming support). The NIPS is used as a DBM in FORSTAT and has been used in several other applications. The processing functions provided by NIPS are standard, including: (1) file definition, generation, maintenance, and revision; (2) data retrieval including a query language with logic capabilities; (3) terminal processing (display features are also included); (4) report generation with some formatting features; and (5) a set of utility programs including provision to use COBOL, FORTRAN, and other languages in a subprogram call mode of operation.

NIPS can operate under all of IBM's most used operating systems, and the terminal servicing features will accommodate IBM and other

manufacturers' compatible terminals. NIPS is a self-contained package that provides its own programming language and its own query language, as well as the necessary language for data definition. In this, NIPS differs from many commercial DBMs which use COBOL or PL-1 as their programming language.

Because of the decision to base the WWMCCS computer system around the Honeywell 6000 series, the FORSTAT programs were redone for the Honeywell machines (by IBM programmers), and the converted programs are now operational. Since no adequate DBM was available on the Honeywell machines, the programs were rewritten in COBOL without support of a DBM.

Another Data Base Management system in the DoD used on the WWMCCS computers is the Force Management Information System (FMIS) developed and operated by the Directorate of Operation Support, Assistant Chief of Staff for Data Systems, Headquarters Strategic Air Command. The FMIS was developed for the Honeywell 6080. The FMIS is an updated and improved version of an earlier DBM, the Time-shared Data Management System (TDMS), a Government-owned set of programs coded in JOVIAL. This system provides standard functions with some emphasis on fast file updating and formatting for visual displays.

#### H. SUMMARY

The design and construction of teleprocessing systems that are cost-effective involve standardization of protocols and programs wherever possible. The standardization problems are more pronounced and the lack of standards incurs greater costs in DoD systems because some teleprocessing systems are operated by several different user organizations, and there is often a requirement to interconnect these different systems.

Problems ensuing from different protocols are already surfacing and are causing delays and cost increases at an early stage in the development of new systems. This amply demonstrates the even larger costs,

delays, and system inefficiencies that will arise if steps are not taken to formulate and sponsor standard protocols for use wherever possible throughout DoD systems. The recent efforts in this direction must be accelerated wherever possible. Further, while DoD should cooperate with and encourage commercial standards groups whenever possible, because of the urgency of the present situation, interim DoD standards should be independently established as soon as possible.

Similarly, within systems there is a need to prepare and adapt, on a systemwide basis, standard program modules (such as Data Base Management systems) wherever possible. The use of these modules on a systemwide basis will reduce system costs and enable system users to interact in an effective manner. Work in this area should be supported to better determine desirable characteristics for these programs and to provide a basis for determination of program modules which can be standardized.

## REFERENCES

1. Defense Communications System Subsystem Project Plan 2-74 - AUTODIN II (Integrated Data Network) 1976-1982 (U), Defense Communications Agency, October 1973 (FOUO).
2. Support of Air Force Automatic Data Processing Requirements Through the 1980s, Vol. 1, SADPR-85 Report; Vol. 2, Background and Requirements; Vol. 3, Technology (Appendix VI); Vol. 4, Concept and Configurations; Vol. 5, Economic Analysis; Vol. 6, Program Planning, Electronic Systems Division, Air Force Systems Command, L.G. Hanscom Field, Mass., June 1974 (U).
3. Teleprocessing Systems Study, Volume 1 - Final Report, General Electric Company, Bethesda, Md., Report OTP-73-TP-1 by D.J. McKee, R.C. Raymond and W.F. Tiernan, 30 April 1973 (U).
4. Automatic Data Processing Costs in the Defense Department, Institute for Defense Analyses, Paper P-1046 by D.A. Fisher, October 1974 (U).
5. DOD Data Internet Study - Phase II Report (U), Defense Communications Engineering Center, Reston, Va., Appendix F: Requirements Catalog and Synopses (S); Appendix G: Data Network Security Measures (C) Dec. 74.
6. SATIN IV Baseline Requirements Document (U), Headquarters SAC, Offutt Air Force Base, Nebraska, 5 September 1973 (S).
7. Final Report of the Informal Preliminary Working Group on SATIN IV and the IDN (U), Defense Communications Agency, March 1974 (C).
8. Defense Communications System Subsystem Project/Plan 4-73 (U), Defense Communications Agency, April 1973 (FOUO).
9. WWMCCS Intercomputer Traffic Projections for Late 1970's (U), MITRE Corporation, MTR-5126 by R. Beveridge and P. Bruce, 19 May 1972 (S).
10. SPIDER--An Experimental Data Communications System, A.G. Fraser, Bell Laboratories, Murray Hill, N.J., presented at IEEE International Conference on Communications, Minneapolis, Minnesota, June 17-19, 1974.
11. TYMNET--A Terminal Oriented Communications Network, L. Tymes, Tymshare, Inc., Internal Memo; also in AFIPS Conf. Proc., Vol. 38, 1971.
12. Collection of Data on DOD ADP Systems, Memorandum for Secretary of Defense; Chairman, Joint Chiefs of Staff; Director, Defense Supply Agency from Assistant Secretaries of Defense (Comptroller and Installation and Logistics), 11 January 1974.

13. Inventory of ADPE in the U.S. Government for FY 1973, General Services Administration, ADTS, Federal Stock #7610-181-7284, December 1973.
14. Data Systems Automation Program 76-1 (DSAP 76-1) (U), Department of the Air Force, Washington, D.C. December 1973 (FOUO).
15. DOD ADP Systems and the DCS (U), Defense Communications Engineering Center, 31 July 1972 (FOUO).
16. Military Airlift Command Integrated Management System (MACIMS), Telecommunications Programming (U), Department of the Air Force, Scott AFB, Illinois, 20 April 1973 (FOUO).
17. ARPANET: Design, Operation, Management and Performance, Network Analysis Corporation, Glen Cove, N.Y., April 1973.
18. DOD Weapon Systems Software Management Study, Johns Hopkins University, Applied Physics Laboratory, May 1975.
19. DOD Weapon Systems Software Acquisition and Management Study, Mitre Corporation, MTR-6908, May 1975.
20. SITA: Rating a Packet-Switched Network by Phil Hirsch, Datamation, March 1974.
21. Network Reliability by Howard Frank and Lynn Hopewell, Datamation, August 1974, pp. 85-91.
22. Computer Communication Network Design--Experience with Theory and Practice by H. Frank, R.E. Kahn, and L. Kleinrock, AFIPS Conf. Proc., Vol. 40, pp. 255-270, 1972.
23. Terminal-Oriented Computer-Communication Networks by M. Schwartz, R.P. Boorstyn, and R.L. Pickholtz, Proc. IEEE, Vol. 60, No. 11, November 1972, pp. 1408-1423.
24. A Design Model for Teleprocessing Systems by R.C. Raymond and D.J. McKee, Data Networks: Analysis and Design of Third Data Communications Symposium, November 1973, IEEE Catalog Number 73 CH0828-4C.
25. Topological Optimization of Computer Networks by Howard Frank and Wushow Chou, Proc. IEEE, Vol. 60, No. 11, November 1972, pp. 1385-1397.
26. The Interface Message Processor for the ARPA Computer Network by F.E. Heart et al., AFIPS Conf. Proc., May 1970, pp. 551-567.
27. Performance Models of an Experimental Computer Communication Network by J.F. Hayes, Bell System Technical Journal, Vol. 53, No. 2, February 1974, pp. 225-259.
28. The Practical Impact of Recent Computer Advances on the Analysis and Design of Large Scale Networks, First Semiannual Technical Report, Network Analysis Corporation, May 1973.
29. Optimal File Allocation in a Multiple Computer System by W.W. Chu, IEEE Trans. on Computers, Vol. C-18, No. 10, October 1969, pp. 885-889.
30. Review of Computer Networking Technology, Robert P. Blanc, National Bureau of Standards, January 1974.

31. Annotated Bibliography of the Literature on Resource Sharing Computer Networks by R.P. Blanc et al., National Bureau of Standards, NBS Special Publication 384, September 1973.
32. Computer-Communication Networks, Editors Norman Abramson and Frank Kuo, Prentice-Hall, Inc., Englewood Cliffs, N.J., 1973.
33. Teleprocessing Network Organization, James Martin, Prentice-Hall, Englewood Cliffs, N.J., 1970.
34. Systems Analysis for Data Transmission, James Martin, Prentice-Hall, Englewood Cliffs, N.J., 1972.
35. On the Analysis and Modeling of a Class of Computer Communication Systems, W.W. Chu and A.G. Konheim, IEEE Trans. on Communications, Vol. Com-20, No. 3, June 1972.
36. Communication Nets Stochastic Message Flow and Delay, Leonard Kleinrock, McGraw-Hill, Inc., 1964.
37. Communication, Transmission, and Transportation Networks, Howard Frank and Ivan T. Frisch, Addison-Wesley Publishing Co., 1971.
38. Nodal Blocking in Large Networks by Jack F. Zeigler, University of California, Los Angeles, California, UCLA-ENG-7167, October 1971.
39. Simulation of Packet-Switching Networks Controlled on Isarithmic Principals by W.L. Price from Data Networks: Analysis and Design, Third Data Communications Symposium, November 1973, IEEE Catalog Number 73CH0828-4C, pp. 44-49.
40. The Control of Congestion in Packet-Switching Networks by D.W. Davies, IEEE Trans. on Communications, Vol. Com-20, No. 3, June 1972, pp. 546-550.
41. The Control of Congestion in Message Switched Networks by M.C. Pennotti and M. Schwartz, ICC-74, Minneapolis, Minnesota, June 17-19, 1974, pp. 20C-1 - 20C-5.
42. Dynamic Scheduling of Multi-Class Message Flow Through a Packet-Switching Node by E.A. Torbett and J.M. Harrison, ICC-74, Minneapolis, Minnesota, June 17-19, 1974, pp. 20D-1 - 20D-6.
43. Optimizing the Reliability in Centralized Computer Networks by E. Hansler, G.K. McAuliffe and R.S. Wilkov, IEEE Trans. on Communications, Vol. Com-20, No. 5, May 1974.
44. Analysis and Design of Reliable Computer Networks by R.S. Wilkov, IEEE Trans. on Communications, Vol. Com-20, No. 3, June 1972, pp. 660-678.
45. Packet-Switched Communications Networks for Electronic Funds Transfer Systems, Network Analysis Corp., Glen Cove, N. Y. January 1973.
46. Survivability Analysis of Command and Control Communications Networks--Part I and Part II by Howard Frank, IEEE Trans. on Communications, Vol. Com-22, No. 5, May 1974, pp. 589-605.

47. Traffic Considerations in Switched Data Networks by G.J. Clowes and C.S. Jayasuriya from Data Networks: Analysis and Design, Third Data Communications Symposium, November 1973, IEEE Catalog Number 73CH0828-4C, pp. 18-22.
48. An Analysis of Traffic Handling Capacity of Packet Switched and Circuit Switched Networks by Kazuo Itoh and Takao Kato from Data Networks: Analysis and Design, Third Data Communications Symposium, November 1973, IEEE Catalog Number 73CH0828-4C, pp. 29-37.
49. The Economics of Segregated and Integrated Systems in Data Communication with Geometrically Distributed Message Lengths by P.K. Verma and A.M. Rybczynski from Data Networks: Analysis and Design, Third Data Communications Symposium, November 1973, IEEE Catalog Number 73CH0828-4C, pp. 38-43.
50. Simulation of a Communication Processor Under Extreme Loading Conditions by J.D. Spragins, IEEE Trans. on Communications, Vol. Com-20, No. 3, June 1972, pp. 609-619.
51. Loop Transmission Systems--Mean Value Analysis by J.D. Spragins, IEEE Trans. on Communications, Vol. Com-20, No. 3, June 1972, pp. 592-602.
52. An Analysis of Buffering Techniques in Teleprocessing Systems by J.H. Chang, IEEE Trans. on Communications, Vol. Com-20, No. 3, June 1972, pp. 619-630.
53. Demultiplexing Considerations for Statistical Multiplexors by W.W. Chu, IEEE Trans. on Communications, Vol. Com-20, No. 3, June 1972, pp. 603-609.
54. Packet Arrival and Buffer Statistics in a Packet Switching Node by F. Closs from Data Networks: Analysis and Design, Third Data Communications Symposium, November 1973, IEEE Catalog Number 73CH0828-4C, pp. 12-17.
55. Centralization of Dispersion of Computing Facilities by D.N. Streeter, IBM Systems Journal, Vol. 12, No. 3, 1973, pp. 284-301.
56. Economies of Scale in the IBM 360 and 370 by R. Fred Littrell, Datamation, March 1974, pp. 83-88.
57. Programable Front Ending Beats Computer Upgrading by Charles J. Riviere, Data Communications, May/June 1974, pp. 41-48.
58. AT&T Facilities and Services by R.T. James and P.E. Muench, Proc. IEEE, Vol. 60, No. 11, November 1972, pp. 1342-1349.
59. Design of Long Distance Telecommunications Networks: The Telpak Problem by Michael Goldstein, IEEE Trans. on Circuit Theory, May 1973.
60. Experimental Heuristic Procedure to Optimize a Telecommunication Network Under Non-Linear Cost Functions by E. Hansler, Proc. 7th Annual Princeton Conference on Information Sciences and Systems, March 1973.

61. How Transaction Cost Declines as Data Networks Get Larger by David J. McKee, General Electric Information Services, Bethesda, Maryland, Data Communications Systems, September 1973.
62. Modems-Another Look by Jack Stahl from DATACOMM 73, Pre-Symposium Tutorial, November 12, 1973, IEEE Catalog Number 73CH0828-4C.
63. Multiplexer Selection for Effective Data Communications by Donald W. Parker, GTE Information Systems, Moorestown, N.J. from DATACOMM 73, Pre-Symposium Tutorial, November 12, 1973, IEEE Catalog Number 73CH0828-4C.
64. Communication Processors: Who, What & Why?, Staff Report from DATACOMM 73, Pre-Symposium Tutorial, November 12, 1973, IEEE Catalog Number 73CH0828-4C.
65. Minicomputer Survey, Datamation, July 1974, pp. 50-61.
66. Western Union Digital Services by John E. Cox, Proc. IEEE, Vol. 60, No. 11, November 1972, pp. 1350-1368.
67. Bell Laboratory Record, September 1973, pp. 226-232.
68. Estimates of Distributions of Random Variables for Certain Computer Communication Traffic Models by E. Fuchs and P.E. Jackson, CACM, Vol. 13, No. 12, 1970, pp. 752-757.
69. Data Traffic Measurements for Inquiry-Response Computer Communications Systems by A.L. Dudick, E. Fuchs and P.E. Jackson, Proc. IFIP, Ljubljana, Yugoslavia, August 1971, pp. 634-641.
70. A Technical Guide to Computer-Communication Interface Standards by A.J. Nuemann et al., NBS Technical Note 843, August 1974.
71. Synchronous Data Link Control: A Perspective by R.A. Donnan and J.R. Kersey, IBM Systems Journal, Vol. 13, No. 2, 1974, pp. 140-162.
72. Standards Analysis for Future WWMCCS Computer Networking, Dennis W. Fife, Editor, National Bureau of Standards, NBSIR 74-570, August 30, 1974.
73. The Terminal IMP for the ARPA Computer Network by S.M. Ornstein et al., Proc. AFIPS 1972, SJCC, May 22, 1972, pp. 243-254.
74. A New Minicomputer/Multiprocessor for the ARPA Network by F.E. Heart et al., Proc. AFIPS
75. Topological Considerations in the Design of the ARPA Computer Network, H. Heart, I.T. Frisch, and W. Chou, AFIPS Conference Proceedings, Vol. 42, 1973, pp. 529-537.
76. A Protocol for Packet Network Intercommunication, V.G. Cerf and R.E. Kahn, IEEE Trans. on Communications, Vol. Com-22, No. 5, May 1974, pp. 637-648.



## APPENDIX A--TASK ORDER

ASSISTANT SECRETARY OF DEFENSE  
WASHINGTON, D. C. 20301

TELECOMMUNICATIONS

18 OCT 1973

ASSIGNMENT FOR WORK TO BE PERFORMED

BY

INSTITUTE FOR DEFENSE ANALYSES

DATE \_\_\_\_\_

You are hereby requested to undertake the following task:

1. TITLE: Teleprocessing
2. TECHNICAL SCOPE:

Teleprocessing is the interdependence of communications and data processing as a system. The objective of this task is to develop a basis for evaluating the improvements that could result from managing at the teleprocessing (system) level rather than at the computer and communications (subsystem) level. Factors to be considered include: remote versus in-house processing; raw data versus preprocessed data versus compacted data transmission; functional versus circuit switching. Guidance for the management, development, modification and maintenance of teleprocessing system to achieve potential improvements will be developed. This will include consideration of the following areas:

- (a) What information should be transferred and the extent of resource sharing in a computer network. Advantages or problems of information transfer between computers during peacetime periods and during an emergency situation.
- (b) Netting and switching including interfacing, protocol and message formatting for computer-to-computer or terminal-to-computer communications.
- (c) Security procedures for computer-to-computer communications.
- (d) Techniques to achieve "graceful degradation" of the system if computers become inoperative and for structuring the system so that relevant data are still available to system operators if either communications links or computers become inoperative.

(e) Protection of programs and data bases in a given computer in the system against external interference.

(f) Cost of software necessary to successfully implement a network of computers in a command and control system. Means for achieving software compatibility within the system and the effects of establishing a computer network on existing software, including the effects of new computer purchases for the system.

3. SCHEDULE: This task shall commence July 2, 1973 and be completed by June 30, 1974.

4. TECHNICAL COGNIZANCE: Deputy Assistant Secretary. (Systems), ASD(T).

5. SCALE OF EFFORT: Two man-years of effort, including consultants as required by IDA, is authorized for this task. Changes in the scale of effort will not be made without the consent of ASD(T).

6. REPORT DISTRIBUTION AND CONTROL: The Deputy Assistant Secretary (Systems), ASD(T), will determine the number of copies of reports and their distribution. A "need-to-know" is hereby established in connection with this task and access to classified documents and publications, security clearances and the like, necessary to complete the task, will be obtained through the ASD(T).

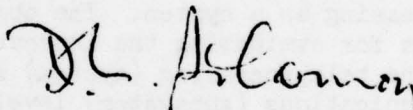

D. L. Solomon  
Acting Assistant Secretary

ACCEPTED:

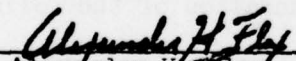
  
Alexander H. Flax  
President, IDA

DATE: 29 October 1973

## APPENDIX B

### AUTOMATIC DATA PROCESSING EQUIPMENT TECHNOLOGY FORECAST

#### INTRODUCTION

Because we are planning a system for implementation in the late 1970s and early 1980s, we need to understand the costs and capabilities of the data processing and communications systems components that will be available at that time. Predictions of ADPE and communications price and performance characteristics were developed by Arthur D. Little, Inc. under contract. Their report, a major source of forecast information, is included as Annex A to Appendix VI of this report. Other research on critical aspects of technology was conducted by Air Force and MITRE personnel.

The major findings of these technology forecasts provided the basis for developing system configurations. In addition, a contract was let to Boeing Computer Services to study the problems and impact of transitioning from dispersed, autonomous computer operations to an integrated operation with computers connected by a telecommunications network. Another contract went to TRW to estimate the impact of new software engineering approaches on software development and configuration management.

#### AUTOMATIC DATA PROCESSING EQUIPMENT

In developing the alternative configurations needed for SADPR-85, the Study Team found it useful to assemble processing systems from basic system components — computers (including main memory), auxiliary storage, and input/output terminals. The Arthur D. Little, Inc. (ADL) technical forecasts were merged into descriptions of these system components.

##### Processors

Large Scale Integration (LSI) processes dominate the manufacturing plans of ADPE vendors. Applied to mass-production items, such as pocket calculators, LSI yields dramatic cost reductions and extraordinary increases in performance. Because of the high design cost of complex chips, however, the benefits of LSI technology are not

fully realized when used in low volume products, such as specialized or high-performance computers. Therefore, a change in computer architecture will take place so that the low costs of LSI can be realized in data processing. Systems will be assembled from mass-produced components — complete processors of various levels of capability — configured around a main memory and operated in both distributed and parallel modes.

In developing this theme, ADL postulated a family of component processors likely to be mass-produced by a typical system vendor. The smallest component processor, level 1, would be comparable to today's small minicomputers. The level 2 processor might compare with an IBM System 370/125. The large, level 3, processors would have performance equivalent to, say, a Honeywell 6000 series CPU.

Since a wide range of ADP capability was needed, four levels of computer system are described. The four computer types (micro-, mini-, mono-, and multiprocessor) are roughly characterized in Table IV. Each would be assembled from memory modules and component processors. Figure 3 illustrates how these components would be organized in a multiprocessor computer, Redundant, level 3 processors are used for the main processing task while redundant, level 2 components are used for file and input/output processing. Multiprocessors of this type are expected to be organized primarily to provide ease of use. Sheer throughput power will be sacrificed to provide for increased functionality — multiple, simultaneous operating system environments, for example.

The next largest class, monoproductors, will more likely be configured for maximum throughput as a direct replacement for current computer systems. Their capabilities will be similar to those of current machines, but their performance will be faster (because of the distributed logic), and their cost lower. In some respects, monoproductors are being overtaken in terms of performance by small machines and will graduate, with the addition of further processors, to the multiprocessor class.

The minicomputer is so-called because it will be of comparable physical size with current minicomputers. In this class, however, there is a rapid increase in performance taking place through the implementation of faster processors, larger memories, and more powerful operating systems. This class will continue to be used for specialized purposes (communications processing, for example), and to support small groups by executing a set of functional area transaction processes.

Table IV

Processor Classes

Characteristic	Micro-		Mini		Mono-		Multi-	
	1977	1985	1977	1985	1977	1985 <sup>[2]</sup>	1977	1985
Typical Use								
On-Line (Users)	1	5-10 or 1	6-10 or several	10-20 and 1	10-20 and 4-6	20-40 and 6-8		See Note [3].
Batch (Streams)	1	1	32-64K	256K+	0.5-2M	2-4M	2-16M	8-64M
Main Memory (Bytes)	4-8	32-64K	512K	4M	10M	32M	50-200M	100-500M
Backing Store <sup>[1]</sup> (Bytes)	300K	500K	real, fixed partitions	virtual	virtual	virtual	multiple virtual memory or machine	
Operating System			ISAM <sup>[4]</sup>	TOTAL <sup>[4]</sup>	DBTG	DBTG	DBTG	plus free form query
Data Base System	direct		10-20K	7-10K	150-250K	75-100K	1.5-2.5M	1-2M
Cost (\$)	1-2K	0.3-0.7K						

[1] Auxiliary storage for system programs and libraries.

[2] This system will probably have multiple main processors by 1985.

[3] Large numbers of simultaneous batch and on-line users will be supported. A test system running today supports 50 batch streams and 200 on-line users on 8MB of main memory.

[4] Data base systems would have capabilities like those named.

Source: Arthur D. Little, Inc., Technology Forecast

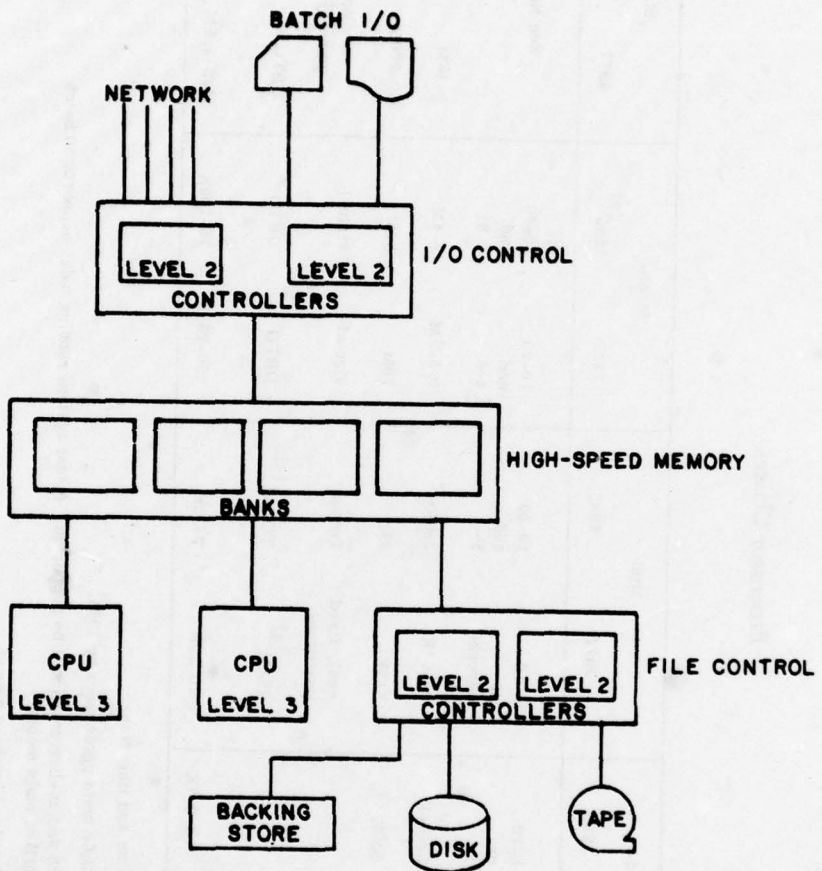

Figure 3 Multiprocessor System

Finally, the microcomputer, similar to today's microprocessor but significantly more powerful, will serve individual applications, such as pocket computers, peripheral device controllers, and intelligent terminals.

The trend to semiconductor memory is expected to continue strongly because of steadily increasing performance and rapidly decreasing cost. By 1980, these memories may have ten times the speed and one-tenth the cost of current production units. Both characteristics will be needed to meet the voracious demands of the virtual operating systems.

#### **Auxiliary Memory**

Few fundamental changes but a steady improvement in performance and reduction in price are anticipated in auxiliary storage technology. Most processing systems will continue to use disk storage systems in a variety of configurations from floppy disks to billion-byte modules. Improvement will come in bit-packing density (leading to higher transfer rates), track-packing density (reducing access times), and head technology (leading to greater use of head per track disks and further reductions in access time). Overall, a decrease in price per bit by a factor of 5 to 10 will be available in the next 8 to 10 years.

In the early 1980s, magnetic bubble or charge-coupled device technology will begin to be commercially available at competitive prices and reliabilities. For small systems these devices will become cost competitive with disk memories; for large systems, they will provide a high speed buffer between disk and main memory.

Table V shows estimated auxiliary storage capacity, performance and price.

#### **Input/Output Terminals**

No dramatic changes in price or performance are seen in the data terminal market. Performance and reliability are usually limited by the electromechanical components of these units, and there aren't likely to be any revolutionary improvements in this area. The greatest changes will occur in the capabilities that can be obtained at reasonable prices in "intelligent" data terminals which will incorporate microcomputer systems.

There will, however, be substantial advances in the engineering of data handling applications. The problems of data entry will be increasingly perceived as an integral part of the overall system problem. As a consequence, more care will be taken in the

**Table V**  
**Summary of Storage Module Cost/Performance Forecasts**  
 (Monthly rentals are typically 2.5% of purchase price)

	1977	1983
<b>Microprocessor Auxiliary Storage</b>		
Capacity	5 million bytes	5 million bytes
Medium	Small fixed disk	Semiconductor, CCD
Access time	10 milliseconds	10 microseconds
Cost	\$2500-3500	\$1500-2500
<b>Minicomputer Auxiliary Storage</b>		
Capacity	50 million bytes	50 million bytes
Medium	Small removable disk	Bubble memory
Access time	30 milliseconds	0.1 millisecond
Cost	\$15-20, 000	\$15-25, 000
Product example	S3/10 disk (5445)	
<b>Monoprocessor Auxiliary Storage</b>		
Capacity	200 million bytes	500 million bytes
Medium	Head/disk cartridge	Head/disk cartridge
Access time	25 milliseconds	20 milliseconds
Cost	\$35-45, 000	\$25-35, 000
Product example	3340	
<b>Multiprocessor Auxiliary Storage</b>		
Capacity	2 billion bytes	2 billion bytes
Medium	Multiple disk unit	Multiple disks
Access time	25 milliseconds	20 milliseconds
Cost	\$180-220, 000	\$90-130, 000
Product example	3333	

selection of data terminals to fit the need, in training people to use them, and in providing the software to help speed and ensure the accuracy of the data entries.

## SOFTWARE

Software trends continue to be far more difficult to identify and project than hardware trends because there is as yet no science of programming. However, a steady increase in operating system capabilities, and some gains in programming productivity are anticipated.

### Operating System Software

Operating system software will take advantage of distributed processing by multiple, special purpose processors. There will be increased use of firmware and hardware implementations of operating system functions. Sophisticated I/O controllers will operate with less CPU supervision or intervention as they independently retrieve, index, and update records. Scheduling and dispatching of applications will be implemented by hardware or by programmable read-only memories.

For large systems, the most striking development in operating system design will be the greatly increased use of virtual memory and virtual machine organizations. Virtual memory systems will deliver much of the promised ease of program design and development, but will cost more than expected in terms of overhead time. These costs can be reduced if great care is taken in performance measurement and evaluation of each application as well as of the system.

The structure of virtual operating systems is likely to permit multilevel security operations by 1980. Possibly this ability will be achieved through implementation of the security kernel techniques described in ESD-MCI-74-1\*. The increased use of virtual memory and machine organizations makes widespread achievement of secure systems more likely.

### Applications Development Software

Familiar higher level languages like COBOL, Fortran and PL/1 will continue to be used, but more developed and reliable data base management systems (DBMS) designed for interactive use will increasingly replace the use of ad hoc programs. As the data management systems evolve, present distinctions between host language and self-contained systems will disappear. As a consequence, professional programmers,

---

\* Reproduced as Ref. B-1: Computer Security Development Summary, ESD, AFSC, L.G. Hanscom Field, Bedford, Mass., ESD MCI-74-1, 30 December 1973.

using host language features, and functional area personnel, using transaction and inquiry features of a self-contained DBMS, will be able to work cooperatively sharing files and processes. Increased availability of user-oriented languages will broaden the user base and provide greater independence from software structures.

In addition DBMS will use improved backup and recovery techniques to guarantee data base integrity and rapid restoration after equipment or software failure. Centralized control of access to shared and unshared data bases will be achieved as will improved capabilities for checking data base update transactions.

#### **Software Acquisition**

Strategies for the acquisition of software will be determined by a source tradeoff which must evaluate the relative merits of prepackaged software, contract programmers and in-house programmers. The real advantages of each will be recognized and exploited.

Prepackaged software is priced from a few dollars to a few hundred thousand dollars depending on the complexity of the system. Typical prices for standard application packages average \$15,000 to \$20,000 per installation. The market is growing as the number of bundled packages offered by computer manufacturers decreases. The Air Force will want to give increasingly serious attention to the utility and cost of packaged software, even when some modifications are required to meet USAF needs. Sizable saving in critical manpower may be possible with this acquisition strategy.

Revisions of familiar applications and systems programs whose logical procedures and structures derive from Air Force policies and methods should probably be developed by in-house personnel.

#### **Software Engineering**

Still an embryonic discipline, software engineering is expected to develop significantly over the next several years. Several trends have been noted that probably will continue:

- Greater automation will be found in test and evaluation as well as in coding. Efforts to use automated requirements analysis as an aid to design will continue, but few applications are foreseen by the late 1970s.

- Increased formalization of the software production process will impose firmer controls on programming language use and on the organizational roles of programmers.
- More analytical proofs of programming correctness will be developed and earlier validation of software correctness will be achieved.
- A more rigorous approach to software design and construction will be reflected by a formalized succession of design levels implemented by strict adherence to ground rules for module definition and inter-module communications.

#### COMMUNICATIONS\*

Technological developments in both local and long haul digital communications will affect the implementation of SADPR-85. Digital switched networks, new methods of sharing wideband circuits, and low cost satellite circuits will all contribute to significant reductions in communications costs.

The communications technology suitable for local use on Air Force bases was examined by the Base Communications Mission Analysis. That study concluded that coaxial cable systems using frequency and/or time-division multiplexing would provide increased service and, given the anticipated demand for computer data terminals, reduced cost. The Air Force Base Information Transfer System (AFBITS) program proposes a prototype installation as soon as possible.

##### Circuit-Switching Systems

The SADPR-85 study examined the availability of leased circuits and the expected costs of alternative sources (AT&T, Western Union, Southern Pacific, DATRAN, etc.). Steady reductions in cost were forecast (50 percent reduction by 1985), with some increase in reliability. Roberts\*\* estimates that costs may decline by over 60 percent in the same period. It seems likely that this rate of cost decrease will continue as new switching and signaling technology is brought into service, e.g., AT&T's Digital Data Service.

---

\* This communications portion of the ADL forecast is provided for the sake of completeness in presenting the ADL view. The results and judgments of this study regarding future data communications are presented in Section VI-A of this report.

\*\* Reproduced as Ref. B-2: Data by the Packet, L. G. Roberts, IEEE Spectrum, February 1974.

### **Packet-Switching Systems\***

The classic alternative to circuit switching has been message switching, for example, the store-and-forward techniques that are used in the AUTODIN network. The overhead and processing delays involved in the usual store-and-forward systems prevent their use for supporting remote, interactive data terminals. The packet-switching concept is based on an ability statistically to share high speed circuits between many users so that each message is transmitted quickly while line utilization is reasonably high. Minicomputers are used to divide the messages into short packets and to control the routing and multiplexing of packets along the network's links. At the same time, the computers provide powerful error detection and correction logic, and alternate routing schemes to increase reliability. Processing costs are falling so rapidly that they will become a negligible part of network costs. Hence, the increased service and performance of packet-switching networks will help them dominate the market in meeting computer communications requirements.

The first large scale use of packet-switching technology was in the ARPANET which now connects more than 50 data processors all over the country. Subsequently, commercial networks have been proposed (Packet Communications, Inc. and Telenet Corp.) and the proposed successor to AUTODIN (AUTODIN-II or the Integrated Data Network) will be a packet-switching network.

The economics of the commercial networks appear attractive for relatively small users, but the workloads associated with Air Force bases suggest that private networks may be more appropriate.

### **Satellite Communications**

The potential economies of satellite circuits are only beginning to be felt. Long distance circuits provided by satellite are significantly less expensive than land lines or ocean cables — perhaps an order of magnitude less expensive by 1980. By that time a combination of long distance satellite circuits, short distance land lines (less than 50 miles, say), and packet-switching technology could reduce overall communications system costs for some users by a factor of five or six relative to today's costs. More thorough analysis of the requirements of each specific application must be made before accurate cost estimates are feasible.

\*The definitive judgments expressed here with regard to network costs relative to processing costs and the relative role of packet switching are those of ADL and do not reflect the views of this study.

## SYSTEMS

For most data processing systems the costs of ADPE and communications are descending so much faster than the costs of software development that the latter will constitute a large majority of system costs. This is progressively less true, the more installations that a system requires. For a system involving over 100 installations, equipment costs will continue to be larger than software development costs for some time. Manpower costs, however, are rising while ADPE costs decline so that operations and maintenance costs are becoming a progressively larger fraction of total program costs. These trends point toward increased use of resource-sharing system architectures. The benefits of these systems include the following.

- It remains less expensive to acquire a few large computer systems than many small separate systems delivering equivalent capability.
- Operations and maintenance expense for a few large systems is less than for many medium-to-large ones.
- Specialized equipment and capability can be amortized over a large community of users.
- Workloads may be shared between different processing elements of the system which thus readily adjusts to changing requirements.
- Backup can be provided for failed components and processing centers.
- Cooperation, coordination, and mutual assistance among widely dispersed members of an organization can be enhanced.
- Duplicative data base storage can be reduced, not to minimize hardware cost as much as to ensure that all users are operating on the basis of a common, accurate understanding.

The experience of Boeing Computer Services illustrates that it is both technically feasible and economically beneficial to use a resource-sharing computer network to meet widespread and similar data processing needs. Careful planning and accurate and continuing system performance measurements are essential if the system is to perform well and satisfy its users who have been accustomed to controlling directly their ADPE resource.