

AD-A067 362

MARTIN MARIETTA AEROSPACE ORLANDO FLA
HYBRID COMPUTER SIMULATION STUDIES FOR SYSTEM CONTROL AND TRANS--ETC(U)
MAR 79 J K BISHOP, M K KLUKIS
OR-15438

F/8 17/2
DCA100-77-C-0061
NL

UNCLASSIFIED

SBIE-AD-E100 195

3
OF
AD
A067362





AD-E100 195

9/2

OR 15,438

HYBRID COMPUTER SIMULATION STUDIES
FOR SYSTEM CONTROL AND TRANSMISSION

LEVEL III

AD A0 67362

Computational Sciences Laboratory
Martin Marietta Corporation
Post Office Box 5837
Orlando, Florida 32855

March 1979

Final Report for Period June 1978 to March 1979

DDC FILE COPY

DDC
RECEIVED
APR 17 1979
B

pared for

Defense Communications Agency
Defense Communications Engineering Center
1860 Wiehle Avenue
Reston, Virginia 22090

DISTRIBUTION STATEMENT A

Approved for public release;
Distribution Unlimited

79 03 30 027

UNCLASSIFIED

SECURITY CLASSIFICATION OF THIS PAGE (When Data Entered)

REPORT DOCUMENTATION PAGE		READ INSTRUCTIONS BEFORE COMPLETING FORM
1. REPORT NUMBER OR 15,438	2. GOVT ACCESSION NO.	3. RECIPIENT'S CATALOG NUMBER
4. TITLE (and Subtitle) HYBRID COMPUTER SIMULATION STUDIES FOR SYSTEM CONTROL AND TRANSMISSION		5. TYPE OF REPORT & PERIOD COVERED Final Report June 1978 to March 1979
		6. PERFORMING ORG. REPORT NUMBER
7. AUTHOR(s) Richard E. Israel, Dr. Gregory J. Sauer, Thomas I. Lyon, J. Kenneth Bishop, M. Keith Klukis, Debra J. Miles		8. CONTRACT OR GRANT NUMBER(s) DCA100-77-C-0061 <i>me</i>
9. PERFORMING ORGANIZATION NAME AND ADDRESS Martin Marietta Corporation Orlando Division P.O. Box 5837, Orlando, Florida 32855		10. PROGRAM ELEMENT, PROJECT, TASK AREA & WORK UNIT NUMBERS
11. CONTROLLING OFFICE NAME AND ADDRESS Defense Communications Agency Defense Communications Engineering Center 1860 Wiehle Avenue, Reston, Virginia 22090		12. REPORT DATE March 1979
		13. NUMBER OF PAGES 304
14. MONITORING AGENCY NAME & ADDRESS (if different from Controlling Office)		15. SECURITY CLASS. (of this report) Unclassified
		15a. DECLASSIFICATION/DOWNGRADING SCHEDULE NA
16. DISTRIBUTION STATEMENT (of this Report) Approved for public release; distribution unlimited.		
17. DISTRIBUTION STATEMENT (of the abstract entered in Block 20, if different from Report)		
18. SUPPLEMENTARY NOTES <i>403 238</i>		
19. KEY WORDS (Continue on reverse side if necessary and identify by block number)		
AUTOVON	Simulation	Communication Networks
AUTODIN	Performance Monitors	Troposcatter
DSCS	Diversity Receivers	Line of Sight
System Control	DRAMA	ATEC
Hybrid Computer	Communication Systems	
20. ABSTRACT (Continue on reverse side if necessary and identify by block number)		
<p>This report documents the results of the second 9 months of simulations and studies in support of system control and transmission systems for the Defense Communications Agency. Section 1.0 describes and documents simulations and study results for system control of the Defense Communication System with deployment of future digital subsystems. Section 2.0 describes and documents the hybrid computer simulation of troposcatter and line-of-sight</p>		

(over)

UNCLASSIFIED

SECURITY CLASSIFICATION OF THIS PAGE(When Data Entered)

20. ABSTRACT (Continued)

digital transmission systems and support software. Section 3.0 describes the hybrid computer remote terminal support for personnel at the Defense Communications Engineering Center.

UNCLASSIFIED

SECURITY CLASSIFICATION OF THIS PAGE(When Data Entered)

FOREWORD

This report documents the results of the second 9 months of simulations and studies in support of system control and transmission systems for the Defense Communications Agency, Defense Communications Engineering Center, under Contract DCA100-77-C-0061.

Section 1.0 describes and documents simulations and study results for system control of the Defense Communication System with deployment of future digital subsystems. Section 2.0 describes and documents the hybrid computer simulation of troposcatter and line-of-sight digital transmission systems and support software. Simulations developed during this contract have been made available to the Defense Communications Engineering Center at Reston, Virginia, via remote hybrid computer terminal. Section 3.0 describes the hybrid computer remote terminal support for personnel at the Defense Communications Engineering Center.

ACCESSION for	
NTIS	White Section <input checked="" type="checkbox"/>
DDC	Buff Section <input type="checkbox"/>
UNANNOUNCED	<input type="checkbox"/>
JUSTIFICATION _____	
BY _____	
DISTRIBUTION/AVAILABILITY CODES	
Dist. <input type="checkbox"/> <input type="checkbox"/> or SPECIAL	
A	

79 03 20

CONTENTS

1.0 System Control 11

1.1 Computer Aids and Data Base Requirements for the Expanded System Control Model 13

1.1.1 Controller Procedures for Network Perturbations 13

1.1.2 High Speed Simulator - Controller Aid 17

1.1.3 Routing Plan Verifier (RPV) 18

1.1.4 Channel Reassignment Diagram (CRD) 25

1.1.5 Primary Data Base 28

1.2 DCS Simulation Test Bed with Digital Subsystems 28

1.2.1 AUTODIN 33

1.2.2 AUTOSEVOCOM 33

1.2.3 DSCS/RTAC 34

1.2.4 Automated Technical Control (ATEC) 34

1.2.5 Traffic Data Collection System (TDCS) 35

1.2.6 Automatic Central Alarm System (ACAS) 36

1.2.7 TCC-39 Switch 36

1.3 Simulation Study and Analysis 37

1.3.1 Busy Hour Scenarios 37

1.3.2 Scenario SC1101A/C - Loss of Largest Transmission Link in Europe 40

1.3.3 Scenario - SC1112A/C Transmission Loss in Germany 52

1.3.4 Scenario SC1315A/C - Multiple Transmission Path Failure 58

1.3.5 Scenario SC1324A/C - Switch Failure at Feldberg 62

1.3.6 Scenario SC1127A/C - Partial Loss of Node Multiplex Capability 73

1.4 Simulator Enhancements 78

1.4.1 Common Equipment Update 78

1.4.2 Network Diagram Update 85

1.4.3 Preliminary Routing Plan Verifier 86

1.4.4 Simulation Command Options 86

1.4.5 AUTOVON Model Update 88

2.0 Transmission System Simulation. 89

2.1 Digital Line-of-Sight Modem Simulation 90

2.1.1 Simulation Time Scale 90

2.1.2 DRAMA Data Input and Transmitter Simulator. 90

PREVIOUS PAGE NOT FILMED
BLANK

2.1.3	QPR/QPSK Modulator Simulation	93
2.1.4	QPR/QPSK Receiver Simulation.	99
2.1.5	Receiver Clock Simulation	104
2.1.6	Diversity Switch Simulation	104
2.1.7	Eye Quality Monitor	105
2.1.8	Four-Level FM Modulation Technique.	105
2.1.9	Eight-PSK Modulation Technique.	110
2.1.10	Three-Level FM Partial Response Digital Modulation Technique	113
2.1.11	DAR Digital Troposcatter Modem Simulation	115
2.2	Fading Channel Simulation.	118
2.2.1	Tropospheric Scatter Simulation	118
2.2.2	Line-of-Sight Multipath Channel Simulation.	121
2.2.3	Line-of-Sight Rayleigh Fading	121
2.2.4	Channel Test and Validation	121
2.3	Electromagnetic Vulnerability Simulation	121
2.4	Adaptive Decision Feedback Equalizer (ADFE).	125
2.4.1	Intermediate Frequency Amplifier.	125
2.4.2	Forward Equalizer Input	127
2.4.3	Forward Equalizer Processor	127
2.4.4	Forward Equalizer Delay	127
2.4.5	Megahertz Baseband Converter and Receive Finite Integrator.	129
2.4.6	Analog Baseband Combiner.	129
2.4.7	Forward Equalizer Error	130
2.4.8	Time Tracking Detector.	130
2.4.9	Time Tracker Digital Filter	130
2.4.10	Time Tracker Phase Shifter.	130
2.4.11	Backward Equalizer Channel Card	130
2.5	Support Software	132
2.5.1	Power Spectral Density.	133
2.5.2	Bit Error Test.	134
2.5.3	Filter Alteration	136
2.5.4	System Configuration.	138
3.0	Remote Terminal Support	141
	References	143
 Appendixes		
A.	Overseas AUTOVON Network Data	A-1
B.	Simulator Command Inputs.	B-1
C.	Baseline Scenarios.	C-1
D.	DRAMA QPR-QPSK Hybrid Simulation.	D-1
E.	Software Support Graphic Displays	E-1
F.	Abbreviations and Acronyms.	F-1

ILLUSTRATIONS

1-1	System Control Development	11
1-2	Controller Procedure Flow Diagram for Equipment Failure	14
1-3	Controller Procedure Flow Diagram for Traffic Overloads	16
1-4	Example Stress in Germany	20
1-5	Functional Flow Diagram for Routing Plan Verifier	22
1-6	Flow Diagram for Node Pair Fault Diagnosis and Route Verification	23
1-7	Sample RPV Display Format Illustrating Route Listing and Fault Diagnosis	24
1-8	Sample RPV Display Format Illustrating Diagnostic- Only Display	25
1-9	Example Triangle Link Reassignment	26
1-10	Flowchart for Channel Reassignment Diagram	26
1-11	Initial CRD Display format for Feldberg Switch	27
1-12	Interim Display with Computer Update	27
1-13	DCS Transmission System Connectivity for Simulation Studies	32
1-14	European AUTOVON	32
1-15	Link and Nodal Configuration of European AUTOVON Model	38
1-16	Transmission Connectivity for Simulation Studies	39
1-17	Network Connectivity as a Result of SC1101	41
1-18	Network Precedence and Link Status for SC1101 at 45 Minutes.	41
1-19	RSJ Percent Utilization with No Controls	42
1-20	Node Pair Statistics for SC1101 at 45 Minutes	44
1-21	Nominal European Routing Plan	45
1-22	IST Percent Utilization with Routing Plan Update at 45 Minutes	46
1-23	Network Precedence and Link Status for SC1101 with Routing Plan Change	49
1-24	Node Pair Status for SC1101 with Routing Plan Change	50
1-25	Network Precedence and Link Status for SC1101 with Composite Control	52
1-26	Network Connectivity Resulting from SC1112	53
1-27	Network and Precedence Status Prior to and Following Perturbation for SC1112	54
1-28	Link Status Following Perturbation for SC1112	55
1-29	Network and Precedence Status for SC1315 at 60 Minutes	60
1-30	Source Node Statistics for SC1315 at 60 Minutes	60
1-31	Link Status for SC1315 at 60 Minutes	60
1-32	Network and Precedence Status for SC1315 with Routing Revision	61

1-33	Source Node Statistics for SC1315 with Routing Revision	61
1-34	Link Status for SC1315 with Routing Revision	61
1-35	Connectivity Diagram Showing Switch Failure at Feldberg	63
1-36	RSJ Percent Utilization Prior to and Following Implementation of DCC	64
1-37	Routing Plan Diagnostics	65
1-38	Feldberg Triangles	66
1-39	Link Status Following Perturbation	67
1-40	Reassignment Matrix for Feldberg	68
1-41	Completed Reassignment Matrix for Feldberg	68
1-42	Network and Precedence Statistics Prior to and Following Control Actions	69
1-43	Link Status Following Composite Control Action	70
1-44	Percent Utilization of the Feldberg Triangle Links Prior to and Following Composite Control Implementation	71
1-45	Percent Utilization and Link GOS for Selected European Links	74
1-46	Network Statistics for Loss of Partial Multiplex Capability	76
1-47	Link/Priority GOS for Loss of Partial Multiplex Capability	76
1-48	Source Node Network Statistics for Loss of Partial Multiplex Capability	76
1-49	Network Statistics for Combined Control Action	79
1-50	Link/Priority GOS for Combined Control Action	79
1-51	Source Node Network Statistics for Combined Control Action	79
1-52	Common Equipment Queue Processing - Queue Entry Interpretation.	80
1-53	Functional Flow Diagram for Pending Call Processing	81
1-54	Functional Flow Diagram for Processing Signaling Complete and Random RSJ Reattempt Events	82
1-55	European AUTOVON Network Diagram	85
1-56	Regional Closeup with Alarm Indication	86
1-57	Node-by-Node Routing Plan Display	87
1-58	Diagnostic Only Routing Plan Display	87
2-1	QPR and QPSK Dual Diversity Simulation	91
2-2	QPR/QPSK Data Input Model	93
2-3	QPR/QPSK Modulator	94
2-4	Partial Response Filter Impulse Response, $h(t)$	95
2-5	Partial Response System	95
2-6	Partial Response Filter, Transmitter, and Receiver Filter Transfer Functions	96
2-7	Frequency Response Plot of Composite Partial Response Filter.	97
2-8	Bandpass Filter Simulation	98
2-9	Nonlinear Device Implementation	98
2-10	Line-of-Sight Modern IF/AGC Simulation	100
2-11	Modified Costas Loop Demodulator Model	101
2-12	Two- and Three-Level Detection Simulation	102
2-13	QPR Noise Performance Bit Error Test	103

2-14	QPSK Noise Performance Bit Error Test	103
2-15	QPR/QPSK Bit Timing Recovery Model	104
2-16	Eye Quality Monitor Thresholds	105
2-17	Four-Level FM Dual Diversity System Simulation	107
2-18	8-PSK Digital Modulation Technique	111
2-19	8-PSK Serial-to-Parallel Converter	111
2-20	8-PSK Modulator Module Implementation	113
2-21	Three-Level Partial Response Digital Modulation Technique	114
2-22	DAR Noise Performance Bit Error Test	116
2-23	DAR Rayleigh Channel Bit Error Test	117
2-24	DAR Troposcatter Channel Bit Error Test	117
2-25	Troposcatter Channel Model	118
2-26	Troposcatter Channel Model Implementation	120
2-27	Rayleigh Fading Distribution	122
2-28	Tone or FM Interference	122
2-29	ADFE Simulation	125
2-30	Forward Equalizer Processor	128
2-31	Forward Equalizer Delay and Time Tracker Detector	128
2-32	Analog Baseband Combiner (One Channel)	129
2-33	Forward Equalizer Error	131
2-34	Time Tracker Phase Shifter	132
2-35	Backward Equalizer Channel	132
2-36	Power Spectral Density Analog Circuits	134

TABLES

1-1	Nominal Intra-Germany Routing Plan	20
1-2	Revised Intra-Germany Routing Plan	20
1-3	Fault Isolation and Warnings from Routing Plan Verifier	21
1-4	Legend for Routing Plan Verifier Flow Diagrams	24
1-5	Diagnostic Display Options for Routing Plan Verifier	24
1-6	Traffic-Oriented Data Base Elements	29
1-7	Equipment-Oriented Data Base Elements	30
1-8	Network-Oriented Data Base Elements	31
1-9	Simulated TCC-39 Data Base Elements	37
1-10	Channel Reassignment Data for Loss of Partial Multiplex Capability	77
1-11	Routing Table Update for Loss of Partial Multiplex Capability	77
2-1	Rayleigh Channel Measurements	123

PRECEDING PAGE NOT FILMED
BLANK

1.0 SYSTEM CONTROL

This section documents the efforts and results of the final 9-month phase of the System Control Study for Contract DCA100-77-C-0061. This study was comprised of five major tasks oriented toward development of control algorithms and real-time controller interaction methodologies and evaluation of controller position displays and control alternatives for the near-term Defense Communications System (DCS). The development and utilization of simulation tools to achieve these goals has been an integral part of the study (Figure 1-1). The first three tasks were:

- Task 1 Specification of Controller Task and Performance Requirements
- Task 2 Specification of Experimental Design Parameters for Network and Traffic Control Simulation and Studies
- Task 3 Human Controller Oriented Simulations and Studies.

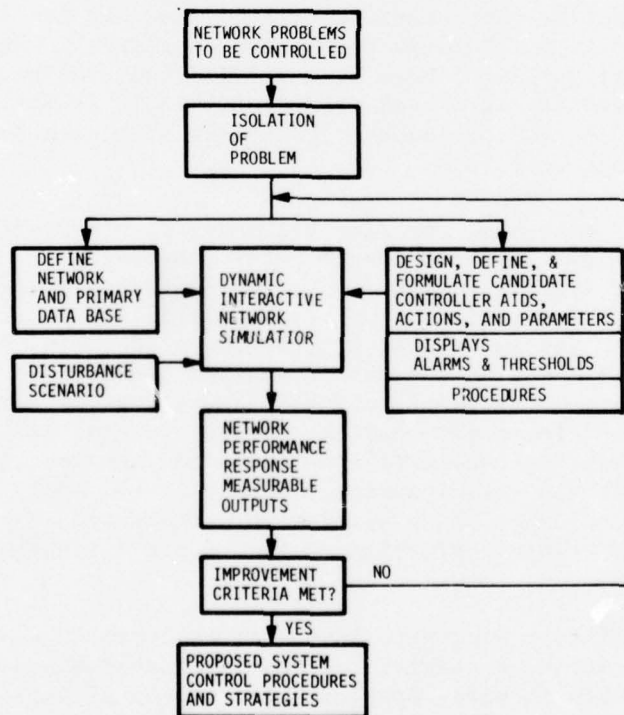

Figure 1-1. System Control Development

These tasks were primarily directed at the human engineering aspects of system control and were accomplished under Phase I of this study. Documentation of Phase I tasks was presented in the interim report, Hybrid Computer Simulation Studies for System Control and Transmission, OR 15,119 (Reference 1). The remaining tasks,

Task 4 Implementation of Expanded System Control Model and Primary Data Base

Task 5 System Control Development and Analysis for Digital Subsystems,

were primarily oriented at developing and verifying control methodologies for the near term integrated DCS, and are the principal subjects of this report. Both simulation and network model enhancements were required to support the Phase II studies. The basic models are discussed in Reference 1, while the Phase II enhancements are documented in this report. The up-graded simulation tool was iteratively exercised in numerous system control scenarios, as depicted in Figure 1-1. These scenario exercises were instrumental in both the development and verification of the study results reported here. Several of the most significant scenarios are discussed in detail.

The efforts and results of Task 4 are presented in paragraph 1.1. The primary data base has been extended for the enhanced control system simulation studies. Specific parameters to be monitored for the information flow diagrams presented in the interim report are detailed. Controller aids that were developed during Phase I have been reevaluated, and new aids, including a routing plan verifier, have been developed. Fault isolation algorithms were reviewed and control procedure flow charts have been developed and are documented in paragraph 1.1.

Paragraph 1.2 discusses the test bed model of DCS Digital Subsystems and its impact on near term DCS system control operations. Under Task 5, interaction of the digital subsystems was investigated, particularly as applied to resource availability and system control of the integrated communications network. The functional interaction of AUTODIN, AUTOVON, and AUTOSEVOCOM subnetworks was analyzed in control scenarios. Reports and directives compatible with TCC-39 and TDCS operations were studied and investigated in the simulation studies. System control implications of the Defense System Communication Satellite (DSCS) and its associated Real Time Adaptive Control (RTAC) were functionally modeled and analyzed in scenario exercises. The results of these studies were presented in paragraph 1.2, while details of specific supporting scenarios are discussed in paragraph 1.3.

Several significant scenarios that were employed in the development and verification of control procedures for the integrated DCS communications network are presented in paragraph 1.3. The impact of DSCS/RTAC on system controllability is demonstrated, and the requirement for specific controller

aids, such as for routing plan update and verification, is emphasized. The potential impact of dynamic channel reassignment capability is also demonstrated.

Several major enhancements were implemented in the network simulator and in the DCS Network Model during Phase II of the Systems Control Study. These modifications increased model realism, extended the simulator applicability, and updated model configuration for existing and projected status. Model realism was enhanced through the completion of the common equipment implementation. The primary data base was extended to include common equipment parameters. All scenarios discussed in paragraph 1.3 employed the common equipment version of the network simulator. The AUTOVON configuration and traffic model were updated to the November 4, 1978 status, which added the CONUS-Donnersberg gateway link. The routing plan and traffic model were updated in accordance with DCS documentation (Appendix A). A new traffic model has been developed that extracts recall traffic from the offered traffic load. Blocked call reattempts are individually queued to improve network realism in response to stress. Several of the scenarios in paragraph 1.3 employed this traffic model.

Improved controller position display options have been implemented in accordance with Phase I study results, and simulator operator-command options have been extended to increase flexibility and to facilitate complex scenario generation. Paragraph 1.4 discusses these simulator updates.

1.1 Computer Aids and Data Base Requirements for the Expanded System Control Model

This section extends the results of the interim report (Reference 1) in the definition of controller aids and data base requirements for effective DCS control. These extensions include the incorporation of the DCS control environment. New and revised controller position displays and computer assisted diagnostic tools are discussed, and controller procedure flow diagrams are presented. The primary data base requirements for realization of these controller aids and for execution of the fault isolation and controller procedures are detailed.

1.1.1 Controller Procedures for Network Perturbations

Network perturbations fall into the categories of equipment failure, traffic overload, or configuration change. The discussion in this section is in terms of failures and overloads, although the procedures apply equally to configuration changes.

For effective implementation of control actions in response to network perturbations, appropriate network performance indexes and fault isolation algorithms must be utilized, as described in Reference 2. The following discussion presupposes the availability of accurate fault isolation algorithms to network controllers.

Equipment Failure

The control strategy developed for equipment failures is depicted in Figure 1-2. Equipment failures can result in both switch and transmission system outages. In the case of a switch failure, the rest of the network sees the failure as if it were a transmission outage, i.e., in the trunk groups connected to the switch.

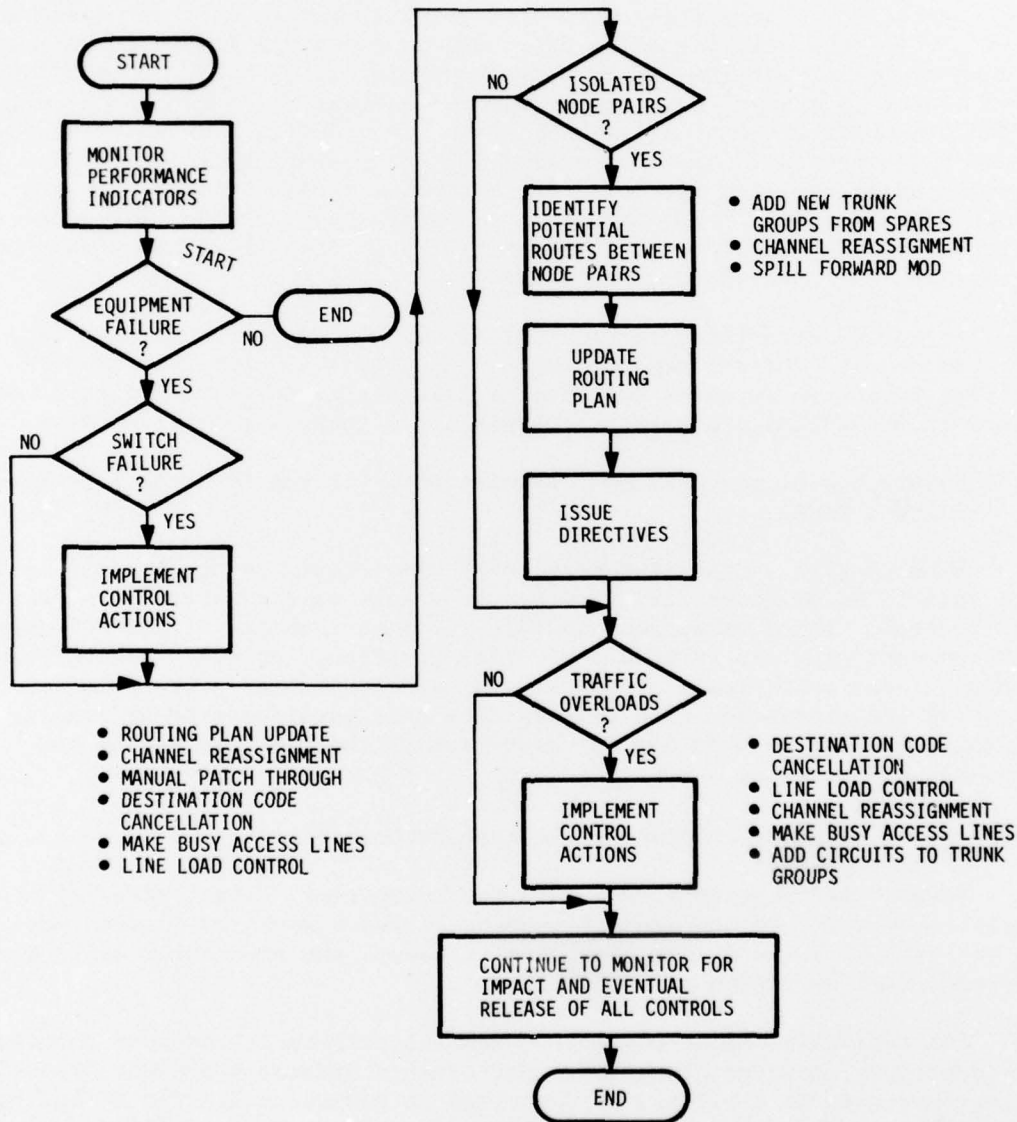

Figure 1-2. Controller Procedure Flow Diagram for Equipment Failure

For equipment failures that occur at a switch, rehomeing of subscribers is used. The procedure is to reconnect the essential subscribers at the failed switch via the interconnecting trunk groups. At this point, the routing directory must be updated to route essential subscriber calls to the new switch. Calls that are attempting to reach the failed switch must also be denied access to the network via destination code cancellation. This control prevents calls that cannot be completed from tying up network resources and prevents a focused overload toward the out-of-service switch.

Equipment failures must be evaluated to determine if isolation of node pairs has resulted from the failure. Once any isolated node pairs have been found, potential routes must be identified for restoration of service between the node pairs. Controller options include addition of new trunk groups from spares, reassignment of existing channels, allowing use of alternate paths at a tandem node via spill forward, and update of the routing table to bypass failed equipment. Of the available controls, routing table update is the most viable, since spare circuits may not be readily available, and spill forward and channel reassignment can be applied only in certain nodal configurations. A controller aid for routing table verification that was developed during this study is discussed in paragraph 1.1.3.

If the equipment failure created no isolated node pairs, or if after the isolated node problem has been resolved, the controller must monitor traffic congestion that results from the remaining in-service equipment handling the traffic formerly carried by the failed equipment. When cases of traffic overloads arise, the controller may alter the traffic load pattern in the affected areas via allocation of additional trunk capacity, destination code cancellation, line load control, channel reassignment, or access line denial. The amount and type of traffic that must be redistributed determines the control actions that are applied.

Traffic Overload

When traffic far in excess of the designed levels is imposed on a network, its call handling capability is greatly reduced due to competition for common resources. The control strategy developed for detection and control of network traffic overloads is shown in Figure 1-3.

This controller procedure utilizes link grade of service as the performance monitor for indication of network stress. Once an individual link GOS exceeds a preset threshold, the traffic overload control procedure is initiated. If more than one link threshold is exceeded and the links are independent of each other, the overload is a localized problem. A general network overload is indicated when a majority of the network links exceed their thresholds. This condition may be caused by an overall increase in traffic throughout the network or by secondary effects from an uncontrolled local or focused overload. Under these conditions, only extreme control actions to reduce offered traffic will allow the network to function effectively.

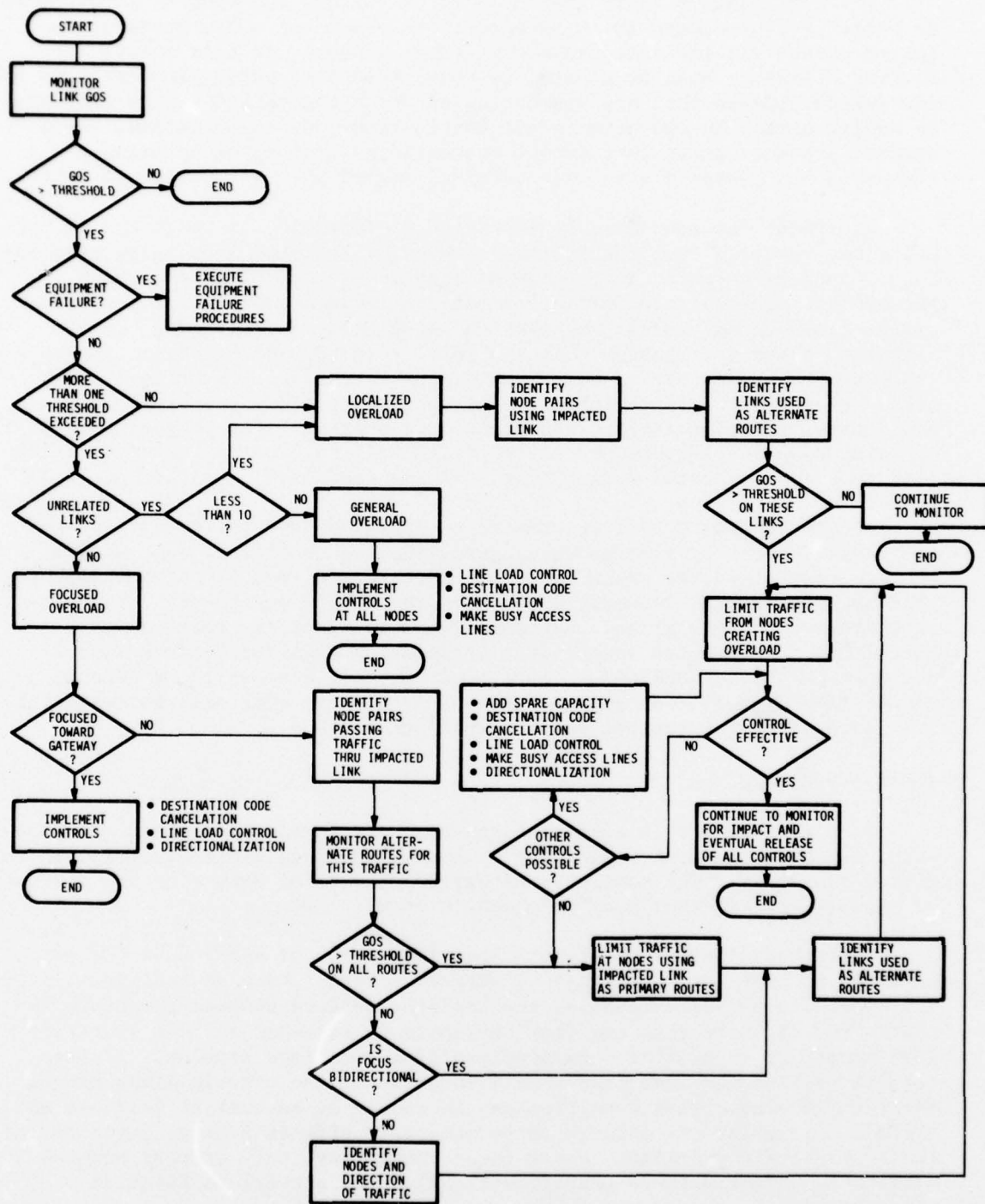

Figure 1-3. Controller Procedure Flow Diagram for Traffic Overloads

Upon identification of a potential local overload, the problem then becomes one of determining which node pairs generate the overload traffic and identification of links that are utilized in alternate routes between these node pairs. This information may be extracted from the routing plan via routing table search methods. If the GOS of links utilized in alternate routes between affected node pairs exceeds a certain threshold (0.08 for a particular network studied), implementation of control actions should commence.

When the links exhibiting high grades of service are related and few in number, a focused overload is indicated. Gateway switching centers are the major locations where focused overloads occur, and the most effective controls were found to be destination code cancellation, line load control, and directionalization. When the focused overload is not toward a gateway, the procedure is similar to that for a localized overload unless a specific directionalization of the overload can be determined.

1.1.2 High Speed Simulator - Controller Aid

The need for a faster than real-time simulator has been evident throughout these simulation studies. A simulator that can access the data base at the theater level for initial conditions, call rates, and connectivity would be very beneficial in selecting proper controls, timing of control actions, and magnitude of the control action. The dynamic simulator developed for the reported studies has the capabilities to provide this requirement for system control.

A simulator of this type resident at the ACOC could be used to determine in a few seconds the extent of performance degradation for both short and long term network abnormalities. Network performance for given procedures and control actions could be evaluated before actual implementation. This controller aid could be very beneficial in support of many system control requirements, including:

- 1 When to expect network improvement
- 2 Determine magnitude of control
- 3 Aid confidence of controller
- 4 Provide guidelines to compare real network response
- 5 Identify pertinent data indicating the effectiveness of controls
- 6 Provide a tool for evaluation of fault isolation algorithms.

The on-line simulator, which can provide both faster than real-time and real-time interactive simulation, can also be used for controller training and maintenance of skill levels. A simulator of this type can accept both

preprogrammed and arbitrary perturbation inputs to test a controller's reaction and ability for resolving a simulated network stress situation. These scenarios may be recorded stresses from the actual network for play-back into the simulator, thus providing added realism for the controller trainee.

The faster than real-time simulator also provides a valuable engineering tool for evaluating and validating changes in system control procedures and network resource allocation. These changes may include:

- 1 New routing tables
- 2 Loss or addition of transmission circuits
- 3 Reformatting of data base displays
- 4 New data for the primary data base
- 5 Proposed controller aids
- 6 New control actions.

In addition to the system control aid and engineering tool applications, the simulator may be interfaced to actual hardware for testing and evaluation.

1.1.3 Routing Plan Verifier (RPV)

The alternate and spill forward routing capabilities of the DCS switched voice network provide network adaptability to transient demands and temporary anomalies. In the event of transmission facility failure, however, the pre-programmed alternate routing schemes may fall short of their intended goal or may even present undesirable side effects. It is imperative that the theater or regional level controller, aware of existing outages, be able to quickly isolate and correct failures and faults in the routing plan. Failure analysis is also crucial in predicting flaws in potential updates to the plan that are intended to decrease the effects of the known stress. This latter is demonstrated during formulation of rerouting control strategies for the scenarios of paragraph 1.3, in that several iterations are frequently required to remove unforeseen and undesirable consequences.

A controller aid to fulfill the need of routing plan verification and fault isolation is presented here. The heart of the routing plan verifier is a computer simulation of the DCS AUTOVON routing scheme. Required data base inputs are the current (or potential) routing plan and current (or predicted) transmission facility capacities. Details and example situations demonstrating the justification for a comprehensive routing plan verifier (RPV) are discussed in the following paragraphs. Subsequently, a functional flow diagram for the proposed controller aid is presented, and a sample controller position output is illustrated. A preliminary version of the RPV has been implemented and employed in the development of control strategies for the scenarios of paragraph 1.3. Sample output from the preliminary RPV is presented in paragraph 1.4.4.

The network routing plan update presents perhaps the most significant control action available to the theater or regional controller, particularly in the event of known stress situations. With particular transmission facility failure, for example, certain node pairs may be logically isolated by the nominal routing plan while physical routing capability exists. In this case, judicious modification of the routing plan can reinstate communications between the isolated node pairs. In the event of node failure, certain node pairs may become isolated because of dependence on tandem paths through the failed node. Again, judicious update of the network routing plan may restore a significant amount of lost communicability particularly among the high priority subscribers. Because of the complex, interdependent nature of the spill forward and alternate tandem routing schemes utilized by the DCS AUTOVON, a seemingly appropriate update to resolve one problem may present unforeseen problems elsewhere. Also, a stress situation existing in one region may create problems in another region. The following composite example will demonstrate these situations, illustrating the need for an on-line routing table verifier.

Germany is the assumed region of interest and the stress consists of transmission facility failure between Donnersberg and Feldberg, and between Langerkopf and Feldberg. This is illustrated in Figure 1-4. The nominal intraregional routing plan for Germany is presented in Table 1-1. Since DON to FEL utilizes FEL and LKF as primary and single alternate, it is obvious that communications from DON to FEL are completely disrupted by the transmission failure in spite of an available route through Schoenfeld. Similarly, FEL to DON and FEL to LKF are logically isolated. The controller at Donnersberg can alleviate this problem by making SCH the primary path to FEL. However, additional problems are created for traffic at SCH destined for FEL, since traffic may now be futilely routed from SCH to DON to SCH (loop back) if the primary path of SCH to FEL registers all trunks busy. If controllers at FEL and LKF also attempt to resolve their problems through independent rerouting, more serious problems such as ring-around-the-rosy or additional isolation may occur. A judicious and coordinated plan, such as presented in Table 1-2, would effectively restore communicability in Germany without introducing additional or alternate routing problems. Formulation of such a plan for even as small a region as Germany takes considerable time because of difficulty in manual verification that no undesirable repercussions will occur for either intra- or interregional subscribers.

Another potential routing hazard occurs from calls spilling into a region of stress. In conjunction with the scenario discussed above with transmission disrupted between DON and FEL and LKF and FEL, calls coming from CONUS and destined to FEL may encounter serious problems. Because of normally heavy congestion of the gateway links, traffic destined to FEL has a reasonable chance of taking the second alternate from CONUS to FEL, which is the spill forward path to DON. Since the DON-FEL path is out, the DON-LKF path is attempted. Due to reduction in tandem path utilization resulting from the transmission failure, the DON-LFK path is then seized

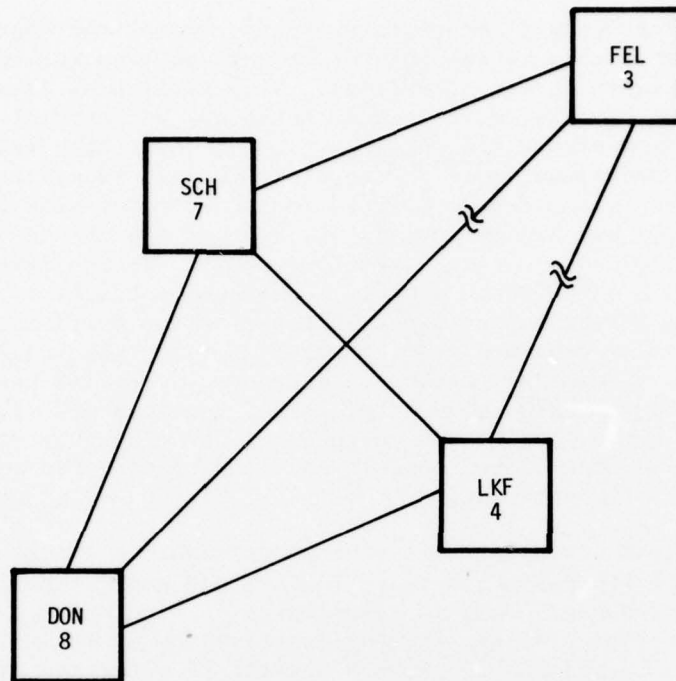

Figure 1-4. Example Stress in Germany

TABLE 1-1. NOMINAL INTRA-GERMANY ROUTING PLAN

	FEL	LKF	SCH	DON
FEL		LKF:D DON:1	SCH:D DON:1	DON:D LKF:1
LKF	FEL:D DON:1		SCH:D DON:1 FEL:1	DON:D SCH:1 FEL:1
SCH	FEL:D DON:S	LKF:D DON:S FEL:1		DON:D LKF:1 FEL:1
DON	FEL:D LKF:1	LKF:D FEL:1	SCH:D LKF:1 FEL:1	

:D denotes destination
:S denotes spill
:1 denotes primary only

TABLE 1-2. REVISED INTRA-GERMANY ROUTING PLAN

	FEL	LKF	SCH	DON
FEL		SCH:1	SCH:D	SCH:S
LKF	SCH:1		SCH:D DON:1	DON:D SCH:1
SCH	FEL:D	LKF:D DON:1		DON:D LKF:1
DON	SCH:1 LKF:1	LKF:D SCH:1	SCH:D LKF:1	

:D denotes destination
:S denotes spill
:1 denotes primary only

with a high probability, and the call releases control at CONUS, spilling forward to DON. The call is ultimately blocked with no chance of preemption, and even high priority subscribers are subject to repeated blockage, while low priority calls may be occupying the primary and first alternate paths from CON to FEL and CON to HIN, respectively. Knowledge of this potential spill entrapment obviates the necessity to cancel the second alternate, CON to DON.

Other routing flaws can be rectified or created through routing plan modification. These include the unnecessary occupation of transmission circuits and common equipment on untenable paths, which occurred in the previous examples. The use of exceptionally long paths (too many tandems) can seriously reduce network efficiency by allowing many circuits to be seized for individual calls. Table 1-3 summarizes faults and flaws of which the network controller should be advised in the event of network stress or potential routing plan modification. Additional inadequacies relating to currently invoked control options, such as link directionalization and link access restriction by precedence, might present a reasonable extension of this scope but will not be further discussed here.

TABLE 1-3. FAULT ISOLATION AND WARNINGS
FROM ROUTING PLAN VERIFIER

- Isolated node pairs
- Potential spill forward entrapment
- Ring around the rosy or loop back
- Untenable paths in routing table
- Excessive number of tandems
- Insufficient carrying capacity of existing routes

Figure 1-5 presents a functional flow diagram for the routing plan verifier. Figure 1-6 provides additional details of the node pair analysis. Table 1-4 is a legend for these illustrations. The required data base for this controller aid is the current or potential routing plan, including spill forward and alternate tandem routing specification and the current or predicted status of the transmission facilities. The controller requests verification for a given region of source and destination nodes and may opt for specific diagnostic and display information. Suggested options are presented in Table 1-5. Figure 1-7 presents a sample controller aid display reflecting the example scenario. The controller requested all routes be displayed with fault and diagnostic information. The region of interest is CONUS and Germany, but only two node pairs are presented here for sake of brevity. The three open routes from CON to FEL are displayed, with :D, :S,

and :1 denoting destination, spill forward, and single tandem nodes. The out-of-service (OOS) status of the DON/FEL and LKF/FEL paths are noted, along with the warning that potential spill entrapment may occur at DON. It is also apparent from the untenable paths emanating from DON that common equipment and transmission capacity may be futilely occupied whenever CON attempts to reach FEL through DON. Figure 1-8 illustrates the diagnostics that would be displayed if the routing plan were to be verified with the solution attempted by the DON controller. Only a summary display of the specific problems is displayed. All of Germany and CONUS is again the region of interest. As previously noted, FEL to LKF and FEL to DON are still isolated, and the potential loopback situation introduced by the tentative control action is noted.

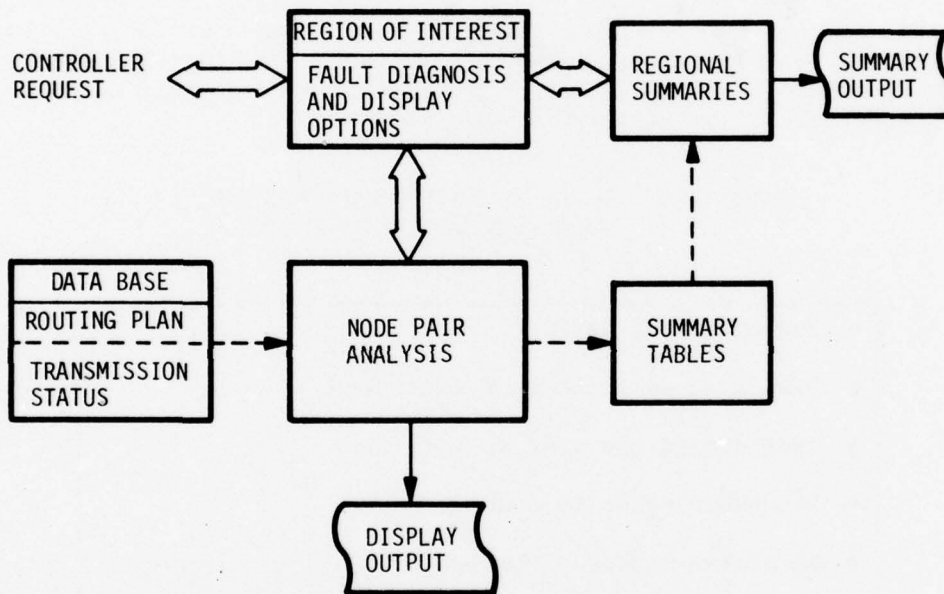

Figure 1-5. Functional Flow Diagram for Routing Plan Verifier

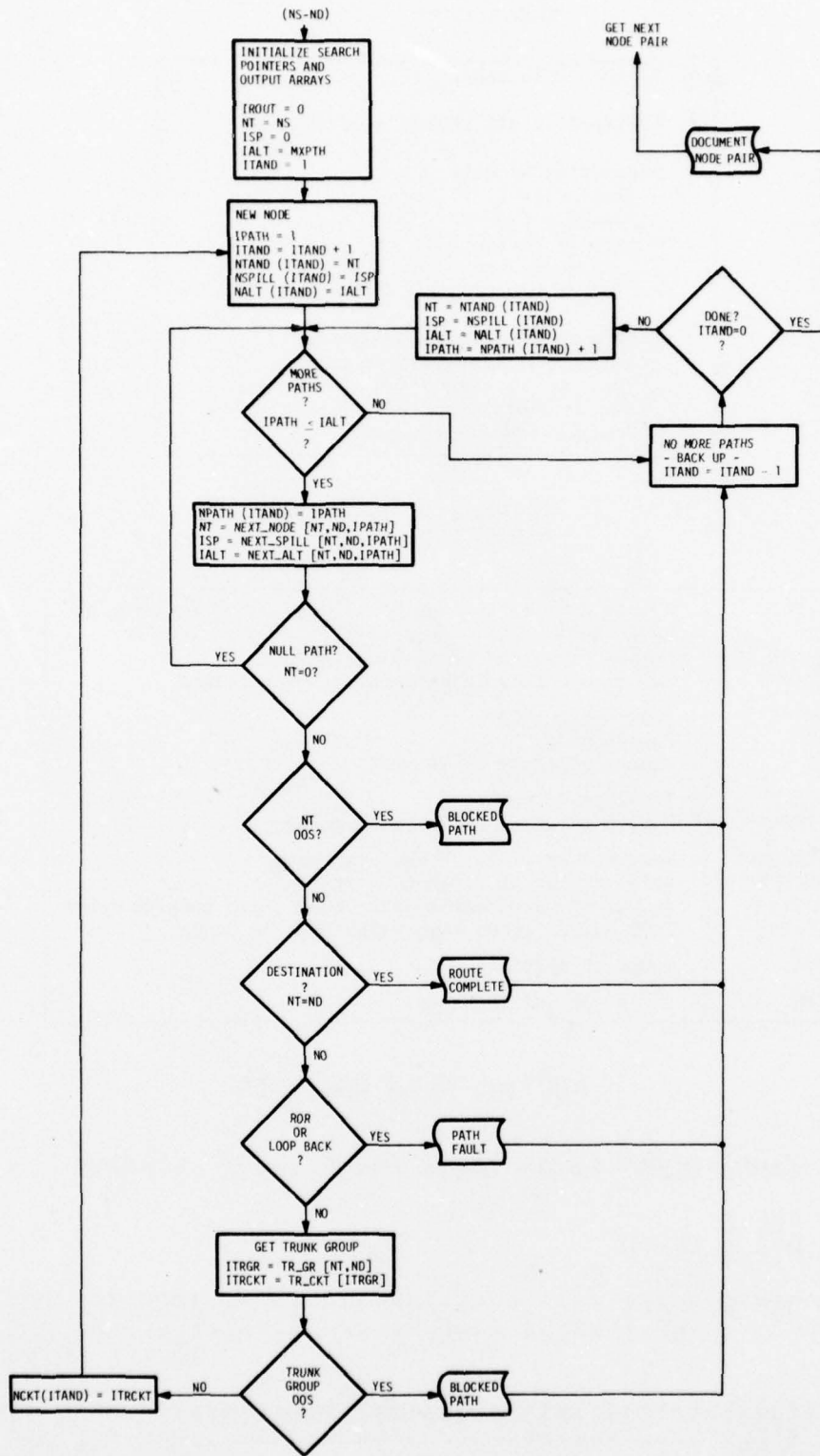

Figure 1-6. Flow Diagram for Node Pair Fault Diagnosis and Route Verification

TABLE 1-4. LEGEND FOR ROUTING PLAN VERIFIER
FLOW DIAGRAMS

- Region of Interest
- List/nolist all routes node to node
- Alarm display only
 - All faults
 - Specific faults
 - Specify thresholds:
 - Maximum acceptable number of tandems
 - Minimum acceptable number of circuits
- List/nolist regional summaries
 - Min/max/avg routes/node pair
 - Min/max/avg tandems/route
 - Min/max/avg circuits/node pair
 - Abbreviated fault summary

TABLE 1-5. DIAGNOSTIC DISPLAY OPTIONS FOR
ROUTING PLAN VERIFIER

IALT	Number of alternate paths allowed from current node
ISP	Spill indication. Potential spill path IF = 0
IROUT	Number of routes being investigated
ITANO	Number of nodes in path being investigated
ND	Destination node
NS	Source node
NT	Tandem node/may be NS or ND
ITRGR	Trunk group number
ITRCKT	Number of circuits in trunk group
NTAND(•)	Node number of (•)th node in route
NSPILL(•)	Spill status of (•)th node in route
NALT(•)	Number of permissible paths from (•)th node in route
NPATH(•)	Path number taken from (•)th node in route
OOS	≡ Out of service
ROR	≡ Ring around the rosy

ROUTING PLAN ANALYSIS

```

FROM TO RTE TAND1 TAND2 TAND3 TAND4 TAND5 TAND6 REMARKS
CON FEL 1 FEL:D
          2 HIN:S FEL:D
          3 MAM:1 FEL:D
          * DON:S *FEL* -----*DON/FEL OOS
          *      LKF:1 *FEL* -----*LKF/FEL OOS
                                   *SPILL ENTRAP

DON FEL *****DON/FEL ISOLATED*****
      * *FEL* -----*DON/FEL OOS
      * LKF:1 *FEL* -----*LKF/FEL OOS
  
```

Figure 1-7. Sample RPV Display Format Illustrating Route Listing
and Fault Diagnosis

ROUTING PLAN ANALYSIS

FROM	TO	RTE	TAND1	TAND2	TAND3	TAND4	TAND5	TAND6	REMARKS
FEL	DON	*****							*****DON/FEL ISOLATED*****
FEL	LKF	*****							*****FEL/LKF ISOLATED*****
SCH	FEL	2	DON:1	FEL	-----				*LOOPBACK

Figure 1-8. Sample RPV Display Format Illustrating Diagnostic-Only Display

1.1.4 Channel Reassignment Diagram (CRD)

This section discusses a proposed computer assisted controller aid to facilitate design of channel reassignment strategies. This tool promises to be particularly useful in the event of switch failure whereby a particular switch is isolated but multiplex capability remains. If manual or semi-automatic crosspatching of transmission circuits is possible, triangle links can be supplemented by the circuits lost at the switch. Figure 1-9 illustrates how the triangle link, 3, can be supplemented by crosspatching circuits between links 1 and 2 at the failed switch, 1. Since links 1 and 2 might normally be used as an alternate to link 3, this reassignment of lost capacity at node 3 can be very effective in restoring lost service to non-3 subscribers. At a highly connected node such as Feldberg in the DCS European theater, many such triangles may occur and many reassignment options can exist. This is demonstrated in Scenario SC1324, paragraph 1.3.5, which simulates loss of Feldberg switching functions. Feldberg has 14 such triangles. An interactive computer-aided display tool is therefore proposed to assist in the development of complex reassignment strategies such as that required for Scenario SC1324. The flowchart for this tool is presented in Figure 1-10. The computer performs the function of reducing network connectivity, capacities, and blocking status to a console display such as illustrated in Figure 1-11. The controller designates each receiving link and amount of supplemented capacity to be assigned. The computer verifies the availability and updates the diagram by inserting the number of allocated circuits in the appropriate X-boxes and updating new and remaining capacity entries as illustrated in Figure 1-12. The process is iterated until the controller is satisfied with his strategy, at which time he directs, or requests the computer to direct, the resolved reassignment strategy. The strategy of SC1324 took approximately 45 minutes to design manually. It is estimated that this could be reduced to about 10 or 15 minutes with the interactive CRD. This controller aid requires access to network configuration, capacity, and link status data base elements.

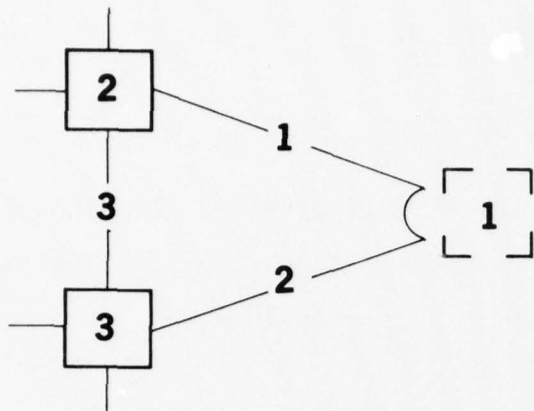

Figure 1-9. Example Triangle Link Reassignment

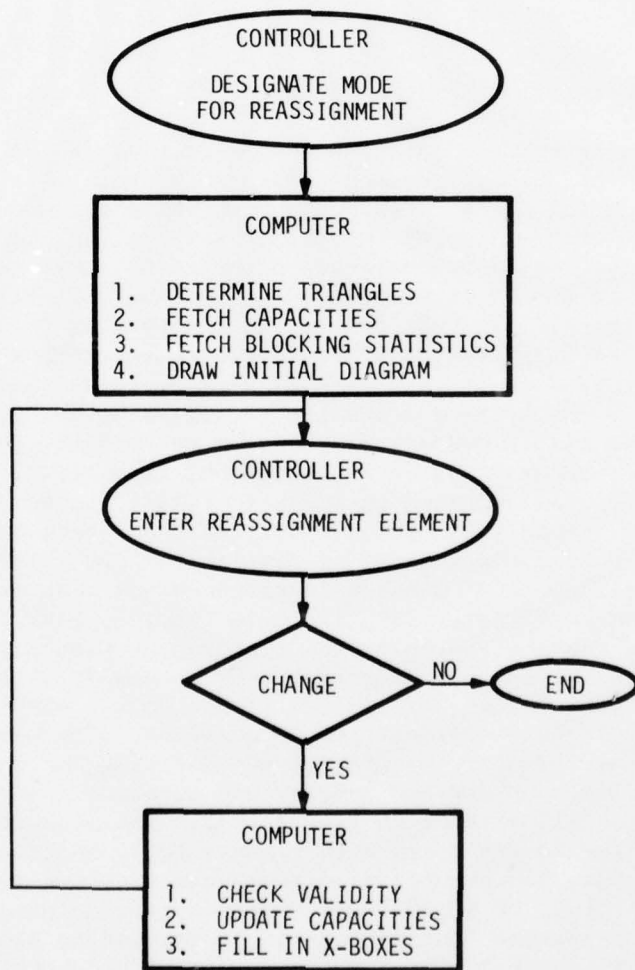

Figure 1-10. Flowchart for Channel Reassignment Diagram

GOS	NOMINAL CIRCUITS									TOTAL CIRCUITS
		28	15	30	20	13	13	30	11	
		LINK								
		2	5	11	12	13	14	15	16	
0.49	27	1	X	X						
.57	9	3	X			X				
.47	19	4	X						X	
.02	14	6		X	X					
.19	7	7		X		X				
.00	34	8		X			X			
.48	5	9		X					X	
.00	8	17			X			X		
.03	34	18			X				X	
.00	15	19				X			X	
.00	9	21				X				X
.25	12	23							X	
.06	12	24							X	
0.04	12	26							X	X
CIRCUITS REMAINING										

Figure 1-11. Initial CRD Display Format for Feldberg Switch

GOS	NOMINAL CIRCUITS									TOTAL CIRCUITS
		28	15	30	20	13	13	30	11	
		LINK								
		2	5	11	12	13	14	15	16	
0.49	27	1	X 10	X 10						37
.57	9	3	X			X				
.47	19	4	X 10						X 10	29
.02	14	6		X	X					
.19	7	7		X		X				
.00	34	8		X			X			
.48	5	9		X 3					X 3	8
.00	8	17			X			X		
.03	34	18			X				X	
.00	15	19				X			X	
.00	9	21				X				X
.25	12	23					X 6		X 6	18
.06	12	24						X	X	
0.04	12	26							X	X
CIRCUITS REMAINING		8	2			7		12		

Figure 1-12. Interim Display with Computer Update

1.1.5 Primary Data Base

Over the course of this study, a data base has been evaluated that provides essential parameters at the ACOC for effective near real-time control of the DCS. The data base elements are grouped as to whether they are traffic oriented, equipment oriented, or network oriented. Typical elements included in the traffic oriented data base are calls offered, blocked, and preempted at each switch, current loading of facilities, call setup delays, lost messages, and message SOS. The TDCS and manual reports currently provide most of this information. Elements of the equipment oriented data base include equipment out of service, status of standby equipment, bit error rate of digital equipment, quality monitors, and failure alarms. This type of data is currently provided by ATEC, ACAS, and manual reports. The network oriented data base elements include connectivity, transmission facility capacities, spare capacities, routing tables, control options in effect, and allocation of network resources. Manual reports are the main source of this type of data.

Traffic, equipment, and network data base elements required for effective real-time control of the DCS are listed by subsystem in Tables 1-6, 1-7, and 1-8.

1.2 DCS Simulation Test Bed with Digital Subsystems

This section discusses the DCS System control test bed model and its representation of current and proposed digital subsystem functions. Specific subsystems considered are AUTODIN, AUTOSEVOCOM, ATEC, TDCS, ACAS, DSCS/RTAC, and the TCC-39 switch. The test bed model is portrayed in Figure 1-13, which delineates the projected 1985 interconnection of AUTOVON, AUTODIN, and DSCS facilities in the European Theater. The primary nodes in the simulation test bed model are the AUTOVON switching centers (V) that are assumed to have coresident AUTOSEVOCOM switching capability. The projected AUTODIN network is outlined by the dashed line digital microwave paths and switching centers denoted D. The satellite terminal symbols denote projected earth station placement in the 1985 DCS and indicate the potential for interswitch satellite communications. The intermediate nodes are portrayed to illustrate the microwave transmission paths and the potential for channel reassignment at the transmission subsystem level. Figure 1-14 depicts the logical structure of the European AUTOVON network model, which is used for the DCS simulation scenarios studying the functional interaction of AUTOVON and the digital subsystems.

The fundamental AUTOVON simulation model was discussed previously in the interim report for this study (Reference 1). Functional revisions implemented since that report include common equipment modeling, network displays, enhancements, and specific controller aid implementations. These are discussed in paragraph 1.4 of this report. The basic European AUTOVON network definition model was also detailed in Reference 1. This model has subsequently been upgraded to reflect the 4 November 1978 CONUS gateway upgrade as summarized in paragraph 1.4. Details of the revised connectivity and routing plan are presented in Appendix A.

TABLE 1-6. TRAFFIC-ORIENTED DATA BASE ELEMENTS

AUTOVON

- TCC-39 Switch
 - Calls offered (by trunk group and by precedence)
 - Calls preempted (by trunk group and by precedence)
 - All-trunks-busy indications (by trunk group and by precedence)
 - Number of trunks busy (per trunk group by precedence)
 - Calls blocked (by trunk group)
 - Calls blocked by common equipment (by trunk group)
 - Calls blocked (by precedence)
 - Incoming calls translated (by trunk group)
 - Calls delayed (dial tone delay > 1 second)
 - Calls offered to switch (network-to-network, network-to-subscriber, subscriber-to-subscriber, subscriber-to-network)
 - Calls accessing switch from ULS, PBX, and direct connection (by access)
 - Calls completed (by switch number)
 - Occupancy of common equipment
- Unit Level Switch (ULS)
 - Calls originated (by trunk group and routine or precedence)
 - Total loop calls originated (routine or precedence)
 - Calls preempted (by trunk group)
 - All-trunks-busy indications

AUTODIN

- TCC-39 Switch
 - Total messages delayed (by precedence)
 - Messages in in-transit storage (by precedence)
 - Oldest message age (by precedence)
 - Messages not delivered (and trace results)
 - Intercept transfers
 - In-transit storage occupied
 - Messages completing orbit
- Packet Switching Node
 - Blocking duration (by destination)
 - Discard/reject report data
 - Packet trace times
 - Packet time outs (by type and precedence)
 - Test packet report data
 - Flow report data
 - Switch packet length report data
 - Preemptions (by precedence)
 - Connections (by precedence)
 - Terminations (by precedence)
 - Transmissions in progress (by precedence)
 - Data packets transmitted and received (by switch and user)
 - Control packets transmitted and received (by switch and user)
 - Total packets (by precedence) per switch
 - Segment lengths available to users (by precedence)
 - Input segments (by precedence) per user
 - Total flows per user

TABLE 1-7. EQUIPMENT-ORIENTED DATA BASE ELEMENTS

AUTOVON

- TCC-39 Switch
 - Signaling buffer controllers (on-line, standby, and failed)
 - Processors (on-line, standby, and failed)
 - Prime power status
 - Tenley controllers (on-line, standby, and failed)
 - Switching controller groups (on-line, standby, and failed)
 - Master timing generators (on-line, standby, and failed)
 - Trunk signalling buffers (on-line and failed)
 - Digital, DTMF, and MF receivers (on-line and failed)
 - DTMF/MF senders (on-line and failed)
 - Intermatrix units (on-line and failed)
 - LKGs (on-line and failed)
 - Bit error rate (by digital transmission group)
 - Out-of-service trunk groups
 - Digital transmission group synchronization (change of sync status)
 - Trunk groups being metered
 - Trunks added or deleted (by trunk group)
 - Digital transmission group buffer overflow (by DTG)
 - Invalid route requests
- Unit Level Switch
 - Switch status

AUTODIN

- TCC-39 Switch
 - Trunks in and out of service
 - Automatic data processors (on-line, standby, and failed)
 - Communications processor links (on-line, standby, and failed)
 - Random access storages (on-line, standby, and failed)
 - Magnetic tape transport/controllers (on-line, standby, and failed)
 - Time division interface units (on-line, standby, and failed)
 - Line conditioning equipment scanners (on-line, standby, and failed)
 - CEF control interface units (on-line, standby, and failed)
 - Master timing generators (on-line, standby, and failed)
 - Prime power status
- Packet Switching Node
 - Trunk/line status (reason for outage)
 - Improper trunk/access line patches
 - Computer diagnostic report data
 - Line diagnostic report data
 - Software diagnostic report data
 - Retransmission report data (by line)

TABLE 1-8. NETWORK-ORIENTED DATA BASE ELEMENTS

AUTOVON

- TCC-39 Switch
 - Controls presently in effect
 - Zone restriction tables
 - Call inhibit tables
 - Digit translation tables
 - Alternate area routing tables
 - Traffic load control level in effect
 - Directory tables
 - Subscriber classmark tables
 - Routing tables (primary and five alternate routes)
 - Message reporting frequencies
 - System timeouts and thresholds
- Unit Level Switch
 - Controls in effect
 - Directory tables
 - Routing tables (primary and one alternate)

AUTODIN

- TCC-39 Switch
 - Controls presently in effect
 - Throttling notifications
 - Collective routing indicator tables
 - Directory tables
 - Subscriber classmark tables
 - Routing tables
 - System thresholds
- Packet Switching Node
 - Controls presently in effect
 - Billing report data
 - Buffer utilization report data
 - Routing tables
 - System thresholds

The following subsections discuss the functional modeling of the specific digital subsystems in the DCS test bed model. These primarily relate to monitoring, reporting, directive, and reallocation functions inherent in the simulator model and its primary data base. Paragraph 1.3 considers specific study exercises that used the expanded system control test bed model. Feedback from these and similar simulation exercises was instrumental in the development of the specific controller aids and procedures presented in paragraph 1.1.

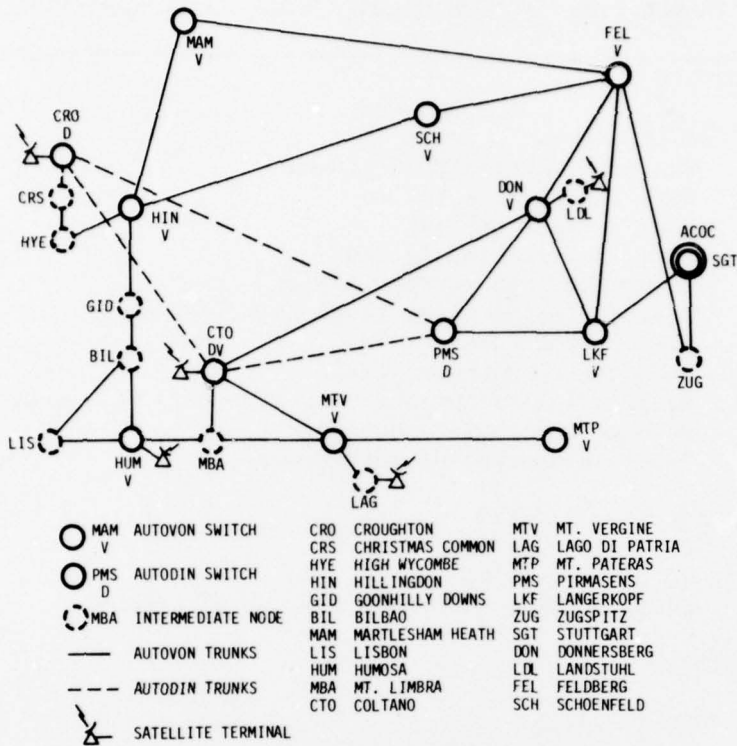

Figure 1-13. DCS Transmission System Connectivity for Simulation Studies

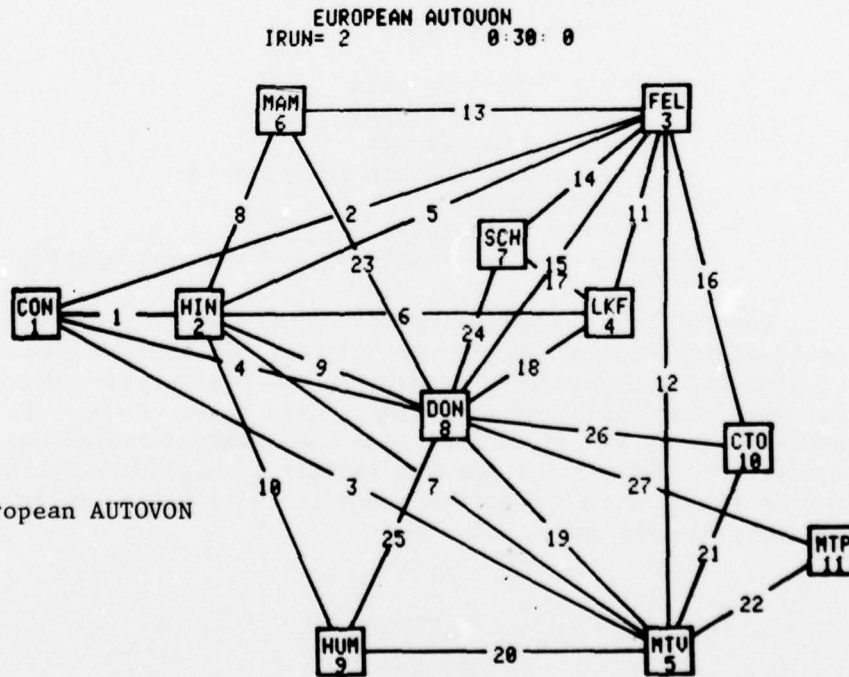

Figure 1-14. European AUTOVON

1.2.1 AUTODIN

AUTODIN I is the DCS store and forward message network, while AUTODIN II is proposed as a packet-switched data network. AUTODIN's principal interaction with real-time system control functions is its rather limited ability to access and share special grade AUTOVON circuits. In the all-digital world, distinction between voice grade and special grade circuits reduces to baud rate demands on the multiplexed channel. Several low baud rate transmissions can be submultiplexed on a wideband channel. If efficient use is to be made of shareable transmission capacity, allocation of switched circuits for AUTODIN overflow and release of AUTODIN circuits for use in the switched voice network will normally be made in terms of minutes or hours. Under normal system operation, the packetized transmission of AUTODIN II will smooth the instantaneous demands by maintaining a backlog of low priority data transmitted on an as-available basis. This permits maximum efficiency of allocated resources and minimizes the effects of short term peak demands. The backlog also permits temporary reallocation of data circuits to supplement switched voice service during short periods of peak demands or stress situations with the subsequent allocation of voice circuits as available to reduce the added AUTODIN backlog. For a large scale hybrid network, this could provide significant smoothing of switched network service and significant increase in overall efficiency of switchable circuit utilization.

The proposed near term AUTODIN II, however, is limited in its ability to interact with AUTOVON through real-time control directives. This is due to the minimal nature of the near term AUTODIN II and to the disparity of parallel transmission facilities demonstrated in Figure 1-3. The principal effect of AUTODIN II is foreseen to be its demand of DSCS circuits through RTAC and the subsequent availability of satellite capacity to supplement AUTODIN demands during peak intervals. This interaction is modeled through the reallocation functions of the network simulator.

1.2.2 AUTOSEVOCOM

AUTOSEVOCOM is the DCS secure voice network. In the all-digital DCS, distinction between secure versus nonsecure transmission facilities ceases. This assumes that proper encryption of the secure signals occurs at the source and destination switches so that transmission facilities need not be secure. The implication of coresident secure/nonsecure switches is that the combined transmission resources potentially raise the relative inefficiency of two independent networks to the efficiency of a single combined network. System control of resources between the two subnetworks is reduced to establishing priority service protocol. This may be a dynamic interpriority structure to permit system controller biasing of the internetwork servicing. Since such integrated secure/nonsecure voice network is not projected in the 1985 DCS, the principal system control implications of the coexisting network are functionally represented by the temporary borrowing and lending of switched transmission capacity to reduce effects of localized overloads and partial loss of transmission capability. This capability is inherent in the network simulator transmission capacity reallocation function.

1.2.3 DSCS/RTAC

The Defense Satellite Communication System (DSCS) subsystem presents the potential for efficient alleviation of localized or regional traffic overloads and loss of transmission capability through demand or near real-time assignment of satellite capacity. The satellite Real Time Adaptive Control (RTAC) is achieved through the network control element (NCE) and the terminal control element (TCE). From an integrated systems viewpoint, the primary NCE functions are satellite status monitoring, demand access allocation, and coordination with the ACOC. Principal TCE functions involve circuit configuration and allocation coordination with accessing DCS facilities (AUTODIN, AUTOSEVOCOM, AUTOVON). The reconfiguration and reallocation are basic network simulator functions, while status monitoring and loss of useful capability through equipment failures or jamming are basic perturbation data base maintenance functions.

1.2.4 Automated Technical Control (ATEC)

ATEC reports and automatic functions assist the technical controller in performance of basic operating and maintenance activities. ATEC supports transmission system maintenance operation through data acquisition, performance monitoring, and analysis. ATEC processors at the sector and nodal level provide additional capability for automation of transmission, traffic, and network control functions. The ATEC system is currently composed of modular elements making up a measurement acquisition subsystem (MAS). Both in- and out-of-band monitoring sets are used for measurement of critical channel parameters. An alarm reporting set provides the capability for remote scanning of equipment alarms and control relay status. Frequency division multiplex (FDM) baseband signal performance monitoring is performed by the baseband monitoring set, which can extract voice channel signals for analysis, conduct baseband spectral analyses, and inject test tones in the baseband. Operational control of the ATEC elements in a particular geographical area is performed by a nodal control subsystem (NCS) that performs system control and management information functions. Coordination between nodal control subsystems is performed by the sector control subsystem located at a Facility Control Office.

The network simulator performs ATEC status monitoring and equipment failure reporting functions only in relation to specific equipment-related scenario-selected events. Scenario events are restricted to those directly affecting circuit and facility availability. ATEC status reporting functions assume the upward flow of the fault-oriented diagnostic reports that are available to the network or regional controller through the simulator's primary data base. In particular, the data base relating to in-service circuit capacities and switch integrity is involved. The automation of transmission traffic and network control functions realized through ATEC processors is simulated by timely control implementation.

1.2.5 Traffic Data Collection System (TDCS)

The current TDCS concept provides for automatic acquisition, formatting, and transmission of traffic data from the AUTOVON 490L switches to the appropriate ACOC on a scheduled basis. Additional functions include rapid switch memory reload, memory update, and acquisition of short term traffic statistics summaries. The TDCS replaces the electromechanical peg count meters, memory peg count registers, traffic usage recorders (TUR), and service observing sets, which were inadequate (too slow, inaccurate, incomplete) in performing effective network management and planning functions. Prior to TDCS, meter readings were manually recorded and mailed to DCA headquarters. Memory register counts were output to punched cards and transmitted to headquarters via AUTODIN for processing. TDCS provides the capability for automatically collecting traffic data at scheduled 60-minute intervals for up to 2000 items of usage, duration, and count data. Special data reports can also be generated, which consist of 20 data items selected from the overall 2000 items. These reports are collected over 15 minute periods, transmitted via AUTOVON to the ACOC, and may be used in implementing network control actions. Data that can be collected on individual calls includes:

- 1 Originating trunk group and trunk
- 2 Terminating trunk group and trunk
- 3 Called number
- 4 Route digit
- 5 Precedence digit
- 6 Final switch matrix connection time
- 7 Four-wire circuit usage time (between switch and ACOC).

Of prime importance is the capability for rapid switch memory reloaded. Loss of switch memory occurs at a switch on the average of once every 24 hours and must be restored from punched cards, resulting in an average of 10 to 30 minutes of switch downtime. The rapid memory reload function provides for reentry of switch memory data from magnetic tape upon operator request.

TDCS data collection and reporting functions are modeled by appropriate windowing of the traffic oriented data base collected in the network simulator, with periodic display or recording through the assumed ACOC controller terminal. Potential effectiveness of the TDCS is seriously reduced by the reporting delay. The network simulator, which is capable of changing its reporting interval, has been used to study the effect of different reporting intervals for traffic oriented data elements. In general, it has been determined that a 15 minute interval is maximum for real-time or near real-time system control to be effective; although certain elements, such as

precedence level node pair statistics, may not become statistically significant except over much longer intervals. Considerable data reduction capability is necessary at the ACOC to provide effective real-time analysis for control functions and long term analysis for planning functions. Switch reload functions are modeled by switch downtime delays in the simulator using the scenario generation functions. Since switch reload reduces to updating routing tables and circuit capacities at the switch from memory or disc resident files, actual simulation reload occurs in milliseconds.

1.2.6 Automatic Central Alarm System (ACAS)

The ACAS provides near real-time indicators for network equipment status monitoring. It automatically scans and senses specific alarm or status indicators at each AUTOVON switch and codes the indicators for transmission to an ACOC for update of a display board and stripchart recording of selected data. Sensing is accomplished using either threshold detection for a cumulative count of a change in a two-state condition for a predetermined number of points, or detection of a change in a two-state condition of a single point. The display provides ACOC controllers with an indication of AUTOVON switch traffic flow, trunk group status, and availability of critical common equipment.

The strip display for each AUTOVON switch controlled by the ACOC contains the switch cluster display, the out-of-service common equipment display, and trunk status display. The switch cluster display reflects both interswitch and intraswitch traffic. The component out-of-service display reflects availability of critical common equipment such as register sender junctors (RSJ), multifrequency transceivers (MFX), and touch call receivers (TCR). It also indicates availability of specific markers, logic, and memory. The trunk status display indicates all trunks busy (ATB) and pilot make busy (PMB) alarms. ATB alarms indicate 100 percent utilization of voice and special grade interswitch trunk groups.

The network simulator display options incorporate several adjustable threshold levels to alarm abnormal congestion of transmission and switching facilities. Stripplot display is also available to simulate ACAS alarms through continuous monitoring and display critical transmission and switching facilities. Interswitch trunk circuit utilization and RSJ availability for each trunk group and switch may be displayed via stripplot medium. Alarm thresholds established on the recorder annotation charts are individually set for each trunk group and for each switch to allow for differences in normal busy hour behavior.

1.2.7 TCC-39 Switch

Most of the traffic-oriented and network data collection and reporting functions associated with the TCC-39 switch were incorporated in the initial simulator development. With the addition of the common equipment model, the initial data base has been extended to include common equipment statistics. The TCC-39 data collection and reporting capabilities are outlined in Tables 1-6 through 1-8 in paragraph 1.1.5. Table 1-9 indicates those related elements currently modeled in the simulators' primary data base and reporting capabilities.

TABLE 1-9. SIMULATED TCC-39 DATA BASE ELEMENTS

Traffic Oriented	
	Calls offered (by trunk group and by precedence)
	Calls preempted (by trunk group and by precedence)
	All-trunks-busy indications (by trunk group and by precedence)
	Number of trunks busy (per trunk group by precedence)
	Calls blocked (by trunk group)
	Calls blocked by common equipment
	Calls blocked (by precedence)
	Incoming calls translated (by trunk group)
	Calls offered to switch
	Calls completed (by switch number)
	Occupancy of common equipment
Network Oriented	
	Controls presently in effect
	Zone restriction tables
	Call inhibit tables
	Alternate area routing tables
	Traffic load control level in effect
	Routing tables (primary and five alternate routes)
	Message reporting frequencies
	System timeouts and thresholds
Equipment Oriented	
	Common equipment (on-line, standby, and failed)
	Digital, DTMF, and MF receivers (on-line and failed)
	DTMF/MF senders (on-line and failed)
	Out-of-service trunk groups
	Trunks added or deleted (by trunk group)

1.3 Simulation Study and Analysis

This section reports on the simulation studies used to design and evaluate controller procedures, actions, and aids for network abnormalities. These studies include the impact of controls and stresses on transmission systems, switch functions, and traffic. Results of both the controlled and uncontrolled system are presented along with displays and data base to support recommended controller procedures. The basic (nominal) scenario was the European AUTOVON with overlays of the DSCS III, AUTOSEVOCOM, and AUTODIN. It was assumed in the analysis that the data needed to isolate abnormal network conditions, detect equipment failures, and reallocate transmission resources could be obtained from either current or proposed network hardware. These include TDCS, ACAS, TCC-39, ATEC, RTAC, and proposed CRM hardware. These subsystems are discussed in paragraph 1.2.

1.3.1 Busy Hour Scenarios

Two busy hour scenarios are employed in the following studies. Both simulate one hour of operation in the DCS European AUTOVON Theater. The November 4, 1978 network model as listed in Appendix A is assumed. The common equipment version of the network simulator is used. Basic scenario SC1100 opts for blocked call dropped, since normal recalls are included in the nominal offered traffic load. Basic scenario SC1300 attempts to model blocked call reattempts to stress environments by first reducing all CONUS traffic to 75 percent nominal, then allowing up to five reattempts per blocked call. The random blocked call recall function used is an exponential distribution with mean times of 0.25, 2.00, 6.75, 16.00, 31.25, and

54.00 minutes for reattempts 1 through 5, respectively. Intraswitch traffic is not included in the model used for either of the basic scenarios, and SC1300 attempts to account for the effect of this traffic by a 50 percent reduction of RSJ units at each switch except CONUS.

These basic scenarios were run for 30 minutes, and the network environments were saved at that time. The scenarios were continued for an additional 30 minutes with 15 minute windowed summaries displayed at 45 and 60 minutes. Subsequent scenarios commence at time $t=30$ minutes through environment restoration. Perturbations are implemented at this time, and control actions, if any, are implemented at time $t=45$ minutes. Windowed summaries are displayed at 45 and 60 minutes. Stripplot data generated for each of the scenarios included percent utilization and GOS for all trunk groups, percent RSJ utilization for all switches, and total network and network by precedence GOS. The data base for all GOS calculations was reset each 15 minute interval. Only stripplot data relative to the individual scenarios is presented here. The operational characteristics of the two basic scenarios with no perturbation controls are discussed in the following two subsections. Since some of the data presented is statistically inaccurate over a 15 minute interval, reference when necessary is made to long term results obtained from 4 hour runs with the same traffic models. Controller position data accumulated over the 4 hour period associated with the two basic scenarios is presented in Appendix C. Figure 1-15 presents a diagram of the European AUTOVON illustrating connectivity with the convention for node number and mnemonics and link number designation. This convention is adhered to in the following scenarios. Figure 1-16 illustrates the transmission system connectivity in Europe, and will be referenced for satellite access and channel reassignment strategies.

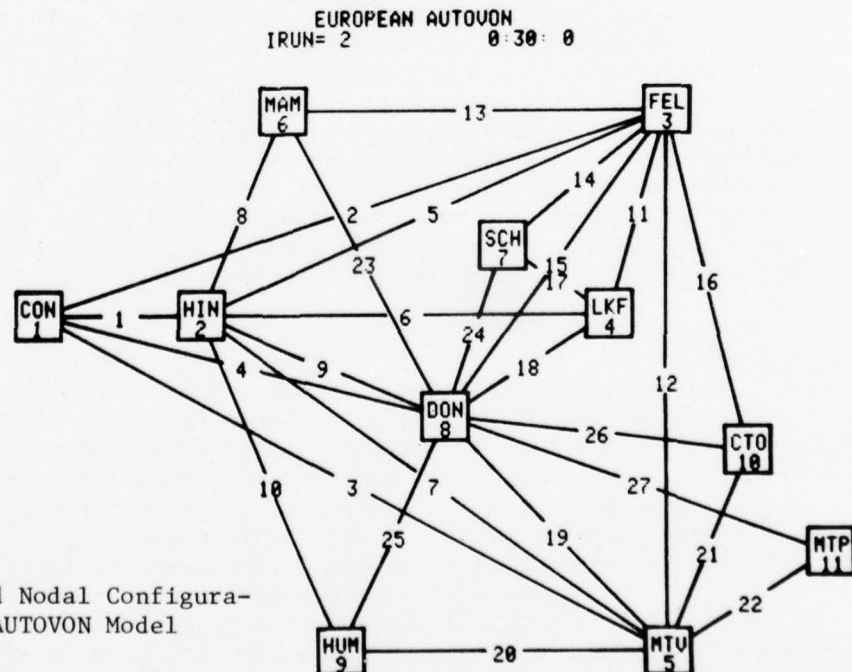

Figure 1-15. Link and Nodal Configuration of European AUTOVON Model

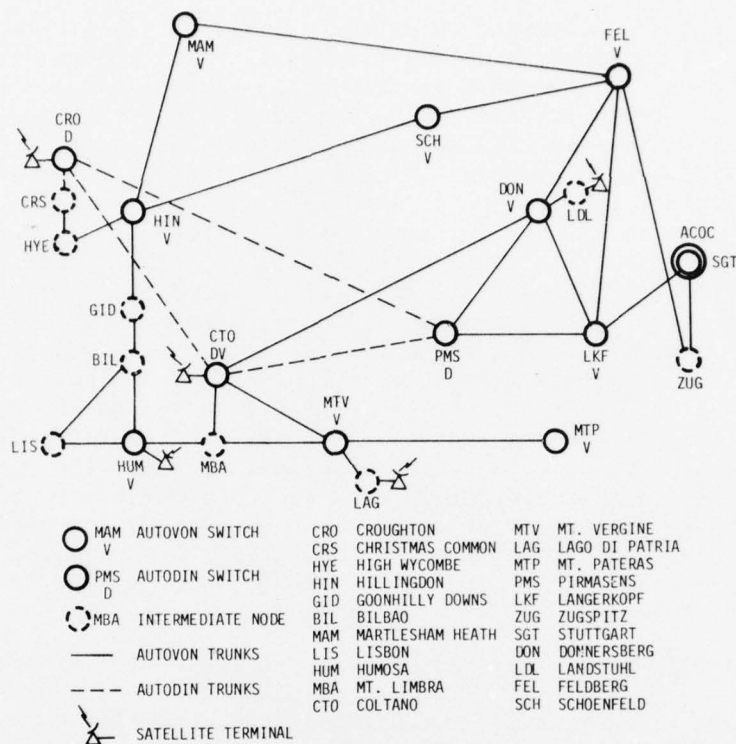

Figure 1-16. Transmission Connectivity for Simulation Studies

Basic Scenario SC1100

This scenario utilizes the nominal traffic loading with no reattempts for individually blocked calls. Common equipment assignments preclude blockage due to unavailability of idle RSJs. Appendix C includes stripplot data and controller position status displays relating to this basic scenario. These displays are presented for comparison with subsequent perturbation and control sequences using scenario SC1100 as a basis. Noteworthy is the heavy congestion of the CONUS gateway links, links 1 through 4. Blockage here runs from about 50 to 70 percent. Also noteworthy is that CONUS traffic is heavily weighted at immediate precedence (level 2) while non-CONUS traffic is most heavily weighted at routine precedence (level 4). This precedence distribution is discussed in detail in Reference 2. Other links with significant blockage are links 9 (HIN to DON) and 23 (MAM to DON) with 30 to 40 percent blockage, and link 27 (DON to MTP) with about 25 percent blockage. Other than for CONUS traffic, which is blocked at about 15 to 20 percent, only CTO to MTP traffic at 7 percent has long term blockage greater than 5 percent. On the average, non-CONUS traffic experiences about 1 percent blockage. Long term overall average is about 10 percent blockage and about 10 percent preemption. For both blockage and preemption, routine is about 14 percent and immediate is about 5 percent. Flash (0) and flash override (1) are nonblocking, and precedence (3) is essentially non-blocked because of the lack of precedence level subscribers using the CONUS gateway. All scenarios designated SC1101 through SC1199 employ SC1100 as their basis.

Basic Scenario SC1300

This scenario has attempted to extract recall attempts from the nominal traffic data to allow modeling of the block call reattempt function in stress environments. Since CONUS traffic has a much higher blockage than non-CONUS traffic, CONUS traffic levels were decreased until inclusion of the recall function yielded similar results to that of basic scenario SC1100. A reduction to 75 percent of nominal provided a reasonable long term fit. The recall function employed allows a maximum of 5 reattempts per original attempt, with average reattempt times of 0.25, 2.00, 6.75, 16.00, 31.25, and 54.00 minutes for reattempts 1 through 5, respectively. Exponentially distributed random functions with the above means are used to compute specific recall delays. Furthermore, common equipment capacities (except for CONUS) were reduced to 50 percent nominal to simulate occupation by intraswitch calls. Appendix C includes stripplot and controller position displays for basic scenario SC1100. This data is supplied for comparative analysis with perturbation and control runs derived from this basic scenario. During the 4 hour execution of this scenario, three attempts were blocked by lack of an idle RSJ. This occurred with one blockage each at LKF, HIN, and MTP. Comparison of the two 4-hour runs in Appendix C demonstrates reasonable long term similarity for normal busy hour operation with the two traffic models. Scenarios labeled SC1301 through SC1399 are developed from basic scenario SC1300.

1.3.2 Scenario SC1101A/C - Loss of Largest Transmission Link in Europe

This network scenario begins with the reported loss by ATEC of the largest transmission link in the European Theater. This link between Mt. Limbar and Mt. Vergine results in the loss of 59 circuits and affects 6 of the 27 AUTOVON ISTs. These ISTs include HIN-MTV (loss of all circuits), FEL-MTV (loss of 12 of 20 circuits), DON-MTV (loss of 11 of 15 circuits), HUM-MTV (loss of all circuits), CTO-MTV (loss of 4 of 19 circuits), DON-MTV (loss of all circuits). The simulated loss of these circuits occurs at 30 minutes into the busy hour period. At the end of 45 minutes, an analysis of the abnormality was made and control actions were taken to reduce the loss of point-to-point communication in the network. The network's response to these actions was assessed at 60 minutes.

The procedures and actions described below take place at the Area Communications Operations Center. The ATEC report of transmission outage, first reported by the TCF, has been forwarded from the sector control center to the ACOC. The first step for a reported failure of communication resources is to determine its effect on overall connectivity in the network. In our simulated case, the controller identifies the out-of-service transmission link and inputs it into a network connectivity program to aid the controller in determining whether network connectivity has been broken. The result of this action is shown in Figure 1-17. It shows that no isolation has occurred due to this perturbation. A check of network statistics (Figure 1-18) indicates no blocking at either flash or flash override precedence levels, moderate blocking of immediate precedence calls, and considerable blocking of routine traffic. Figure 1-19 shows that no undue congestion of common equipment exists. The next step is to ensure that the routing table

EUROPEAN AUTOVON
IRUN=10 1:0:0

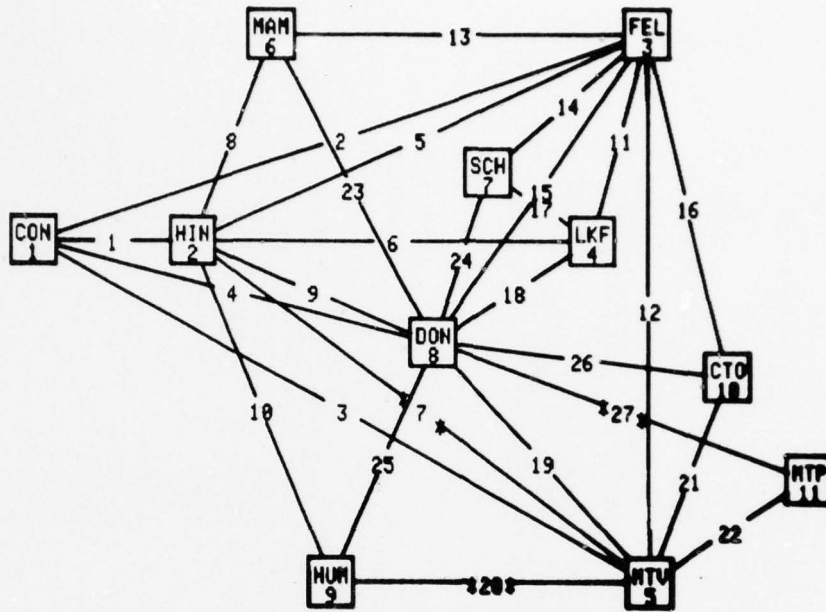

Figure 1-17. Network Connectivity as a Result of SC1101

```

***** 0:45: 0*****
*ACCUMULATED TOTAL NETWORK STATISTICS*
ATTEMPTS BLOCKS COMPLETE PREEMPTED BL/ATT PR/COM
1293 156 1137 102 0.1206 0.0897
***** 0:45: 0*****
*ACCUMULATED NETWORK PRECEDENCE STATISTICS*
PREC ATTEMPTS BLOCKS COMPLETE PREEMPTED BL/ATT PR/COM PREC
0 0 0 0 0 0.0000 0.0000 0
1 2 0 2 0 0.0000 0.0000 1
2 372 3 369 0 0.0081 0.0000 2
3 71 1 70 1 0.0141 0.0143 3
4 848 152 696 101 0.1792 0.1451 4
***** 0:45: 0*****
*ACCUMULATED LINK/PRIORITY GOS STATUS
LINK A TOTAL P0 P1 P2 P3 P4
BLCK/ATTM=X.XX BLCK/ATTM BLCK/ATTM BLCK/ATTM BLCK/ATTM BLCK/ATTM
1** 206/ 393=0.52 0/ 0 1/ 1 103/ 220 0/ 0 102/ 172
2** 265/ 450=0.59 0/ 0 1/ 3 135/ 255 0/ 0 129/ 192
3** 68/ 131=0.52 0/ 0 0/ 0 39/ 78 0/ 0 29/ 53
4** 146/ 240=0.61 0/ 0 1/ 1 72/ 125 0/ 0 73/ 114
5 0/ 104=0.00 0/ 0 0/ 0 0/ 53 0/ 0 0/ 51
6 1/ 77=0.01 0/ 0 0/ 0 0/ 39 0/ 1 1/ 37
7*** 89/ 89=1.00 0/ 0 0/ 0 40/ 40 0/ 0 49/ 49
8 0/ 92=0.00 0/ 0 0/ 0 0/ 35 0/ 2 0/ 55
9 * 23/ 61=0.38 0/ 0 0/ 0 5/ 16 0/ 0 18/ 45
10 14/ 83=0.17 0/ 0 0/ 0 2/ 34 0/ 2 12/ 47
11 0/ 192=0.00 0/ 0 0/ 0 0/ 80 0/ 10 0/ 102
12** 58/ 113=0.51 0/ 0 0/ 0 16/ 38 1/ 4 41/ 71
13 0/ 41=0.00 0/ 0 0/ 0 0/ 13 0/ 0 0/ 28
14 0/ 41=0.00 0/ 0 0/ 0 0/ 7 0/ 4 0/ 30
15 14/ 223=0.06 0/ 0 0/ 0 4/ 51 0/ 12 10/ 160
16 1/ 36=0.03 0/ 0 0/ 0 0/ 6 1/ 6 0/ 24
17 1/ 26=0.04 0/ 0 0/ 0 0/ 3 0/ 2 1/ 21
18 0/ 164=0.00 0/ 0 0/ 0 0/ 37 0/ 16 0/ 111
19*** 37/ 70=0.53 0/ 0 0/ 0 0/ 2 1/ 5 36/ 63
20*** 58/ 58=1.00 0/ 0 0/ 0 13/ 13 6/ 6 39/ 39
21 12/ 43=0.28 0/ 0 0/ 0 2/ 5 0/ 6 10/ 32
22 3/ 111=0.03 0/ 0 0/ 0 0/ 31 1/ 8 2/ 72
23 26/ 87=0.30 0/ 0 0/ 0 5/ 15 0/ 1 21/ 71
24 4/ 46=0.09 0/ 0 0/ 0 1/ 4 0/ 7 3/ 35
25 20/ 81=0.25 0/ 0 0/ 0 2/ 7 1/ 9 17/ 65
26 8/ 65=0.12 0/ 0 0/ 0 0/ 1 1/ 10 7/ 54
27*** 51/ 51=1.00 0/ 0 0/ 0 5/ 5 7/ 7 39/ 39

```

Figure 1-18. Network Precedence and Link Status for SC1101 at 45 Minutes

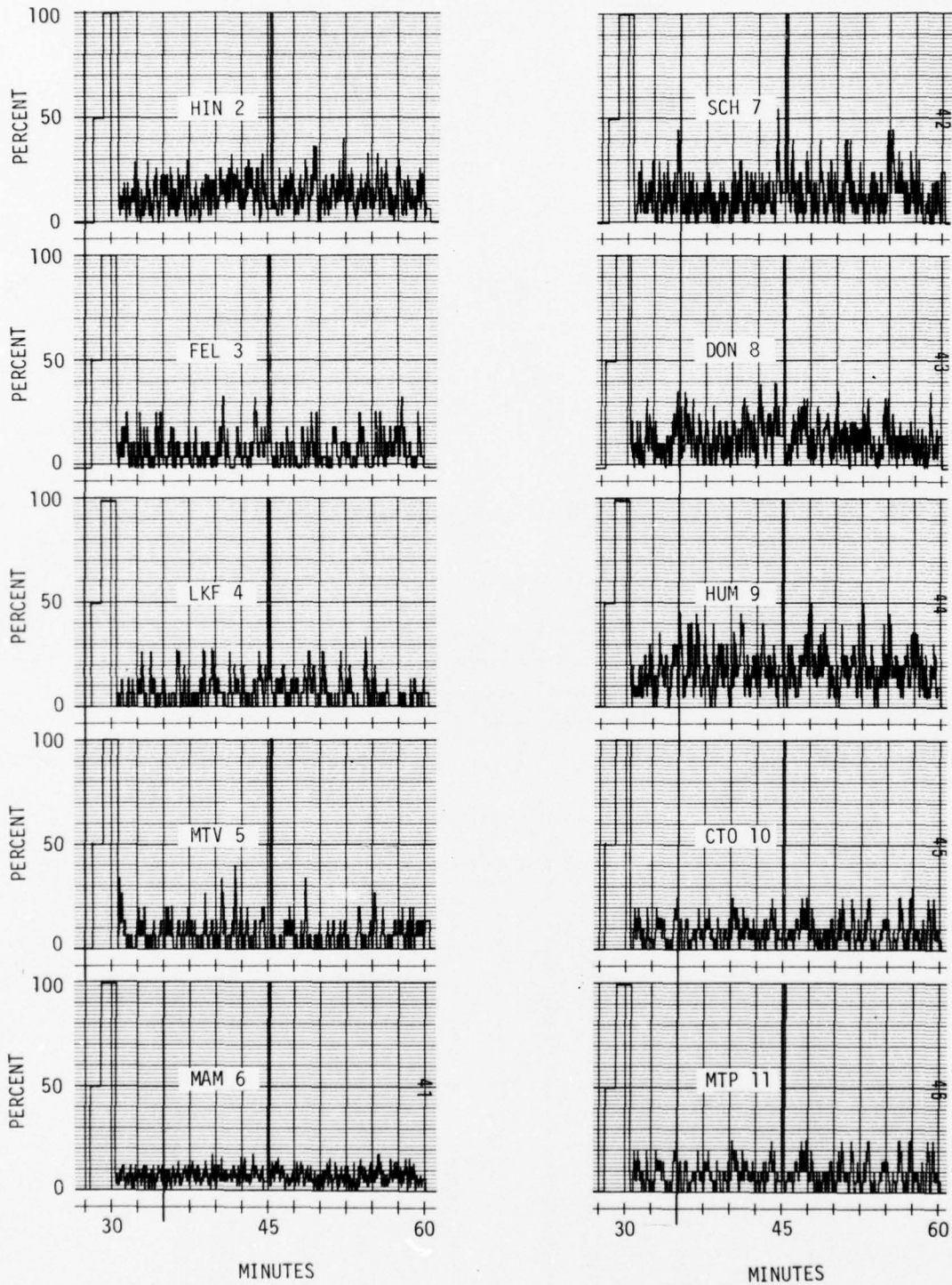

Figure 1-19. RSJ Percent Utilization with No Controls

has provided for point-to-point connection between each and every node. The procedure for accomplishing this is to extract from the data base the 15 minute accumulated node-to-node network statistics and search all combinations for a Blocking Probability = 1.0. A blocking probability of 1.0 does not necessarily indicate logical isolation for this call combination, but only suggests further investigation. In addition to the call combinations with Blocking Probability = 1 (B.P.=1), any call combination not listed should be verified. The node-to-node statistics used are shown in Figure 1-20. From this search the following call combinations are suspect:

3-2	FEL-HIN	7-5	SCH-MTV	5-9	MTV-HUM
5-2	MTV-HIN	9-5	HUM-MTV	11-10	MTP-CTO
10-2	CTO-HIN	5-6	MTV-MAM	2-11	HIN-MTP
11-2	MTP-HIN	10-6	CTO-MAM	7-11	SCH-MTP
2-5	HIN-MTP	11-6	MTP-MAM	8-11	DON-MTP
6-5	MAM-MTV	1-7	CON-SCH	9-11	HUM-MTP

To determine which of these combinations has a valid path through the routing table requires the controller to trace both primary and alternate routes using the routing table shown in Figure 1-21. These procedures can be very time consuming and are subject to controller error. To alleviate the problem of routing plan verification, a controller aid has been designed to locate isolated node pairs and path faults. This is the routing plan verifier discussed in paragraph 1.1. Those node pairs that do not have a valid route are displayed to the controller. If the number of node pairs is small, the controller can manually call up the routing table and connectivity diagram and make a routing plan change to accommodate these call combinations. In performing this function he must pay particular attention to the blocking probability of the remaining ISTs. Strip charts of the ISTs are shown in Figure 1-22. From this analysis it was concluded that a controller aid for modifying the routing table based on the altered connectivity and arrangement of communication resources is a necessity for near real-time control of a switched network.

An algorithm of this type requires access to the link and connectivity data bases to compute the best path based on blocking probability and number of tandem switches. The algorithm must also prevent traversing any one node more than once (loopback).

For the analysis presented, routing plan changes were accomplished manually. For this scenario the only combinations without valid routing were 2-11 HIN-MTP, 9-5 HUM-MTV, and 9-11 HUM-MTP.

The new routes inserted for these call combinations were:

<u>1</u>	HIN to MTP	1	MTV:1
		2	MAM:1
		3	FEL:1
<u>2</u>	HUM to MTV	1	MTV:1
		2	HIN:1
		3	DON:0
<u>3</u>	HUM to MTP	1	MTV:1
		2	DON:1

***** 0:45: 0*****

ACCUMULATED NODE TO NODE NETWORK STATISTICS

NODE	NODE	ATTEMPTS	BLOCKS	COMPLETE	PREEMPTED	BL/ATT	PR/COM	NODE	NODE
2	1	62	11	51	9	0.1774	0.1765	2	1
3	1	74	10	64	15	0.1351	0.2344	3	1
4	1	72	9	63	10	0.1250	0.1587	4	1
5	1	37	9	28	8	0.2432	0.2857	5	1
6	1	28	4	24	3	0.1429	0.1250	6	1
7	1	6	3	5	0	0.3750	0.0000	7	1
8	1	87	18	69	7	0.2069	0.1014	8	1
9	1	24	6	18	2	0.2500	0.1111	9	1
10	1	6	0	6	2	0.0000	0.3333	10	1
11	1	35	6	29	2	0.1714	0.0690	11	1
1	2	34	3	31	6	0.0882	0.1935	1	2
4	2	5	0	5	0	0.0000	0.0000	4	2
6	2	1	0	1	0	0.0000	0.0000	6	2
7	2	1	0	1	0	0.0000	0.0000	7	2
8	2	4	0	4	0	0.0000	0.0000	8	2
9	2	3	2	1	0	0.6667	0.0000	9	2
11	2	2	2	0	0	1.0000	0.0000	11	2
1	3	32	1	31	8	0.0315	0.2581	1	3
2	3	1	0	1	0	0.0000	0.0000	2	3
4	3	31	0	31	0	0.0000	0.0000	4	3
5	3	3	2	1	1	0.6667	1.0000	5	3
6	3	1	0	1	0	0.0000	0.0000	6	3
7	3	7	0	7	0	0.0000	0.0000	7	3
8	3	36	0	36	0	0.0000	0.0000	8	3
9	3	4	1	3	0	0.2500	0.0000	9	3
10	3	20	0	20	0	0.0000	0.0000	10	3
11	3	13	2	11	2	0.1538	0.1818	11	3
1	4	37	4	33	7	0.1081	0.2121	1	4
2	4	3	0	3	0	0.0000	0.0000	2	4
3	4	32	0	32	0	0.0000	0.0000	3	4
5	4	7	1	6	1	0.1429	0.1667	5	4
6	4	12	0	12	0	0.0000	0.0000	6	4
7	4	14	0	14	0	0.0000	0.0000	7	4
8	4	27	0	27	0	0.0000	0.0000	8	4
9	4	12	3	9	0	0.2500	0.0000	9	4
10	4	6	0	6	0	0.0000	0.0000	10	4
11	4	6	3	3	0	0.5000	0.0000	11	4
1	5	15	3	12	1	0.2000	0.0833	1	5
3	5	4	1	3	3	0.2500	1.0000	3	5
4	5	5	1	4	0	0.2000	0.0000	4	5
8	5	8	1	7	0	0.1250	0.0000	8	5
9	5	7	7	0	0	1.0000	0.0000	9	5
10	5	3	0	3	1	0.0000	0.3333	10	5
11	5	12	0	12	0	0.0000	0.0000	11	5
1	6	11	1	10	0	0.0909	0.0000	1	6
2	6	17	0	17	0	0.0000	0.0000	2	6
3	6	3	0	3	0	0.0000	0.0000	3	6
4	6	9	0	9	0	0.0000	0.0000	4	6
7	6	1	0	1	0	0.0000	0.0000	7	6
8	6	4	0	4	0	0.0000	0.0000	8	6
9	6	9	0	9	0	0.0000	0.0000	9	6
1	7	4	0	4	1	0.0000	0.2500	1	7
2	7	1	0	1	0	0.0000	0.0000	2	7
3	7	20	0	20	0	0.0000	0.0000	3	7
4	7	10	0	10	0	0.0000	0.0000	4	7
5	7	1	0	1	0	0.0000	0.0000	5	7
6	7	1	0	1	0	0.0000	0.0000	6	7
8	7	7	0	7	0	0.0000	0.0000	8	7
9	7	4	0	4	0	0.0000	0.0000	9	7
10	7	1	0	1	0	0.0000	0.0000	10	7
11	7	1	0	1	0	0.0000	0.0000	11	7
1	8	30	6	24	5	0.2000	0.2083	1	8
2	8	8	0	8	0	0.0000	0.0000	2	8
3	8	56	0	56	0	0.0000	0.0000	3	8
4	8	35	0	35	0	0.0000	0.0000	4	8
5	8	7	2	5	1	0.2857	0.2000	5	8
6	8	28	2	26	0	0.0714	0.0000	6	8
7	8	19	0	19	0	0.0000	0.0000	7	8
9	8	19	2	17	2	0.1053	0.1176	9	8
10	8	19	5	19	0	0.0000	0.0000	10	8
11	8	15	0	10	1	0.3333	0.1000	11	8
1	9	15	5	10	1	0.3333	0.1000	1	9
2	9	2	0	2	0	0.0000	0.0000	2	9
3	9	1	0	1	0	0.0000	0.0000	3	9
4	9	6	0	6	0	0.0000	0.0000	4	9
5	9	2	2	0	0	1.0000	0.0000	5	9
6	9	5	0	5	1	0.0000	0.2000	6	9
7	9	3	1	2	0	0.3333	0.0000	7	9
8	9	9	2	7	0	0.2222	0.0000	8	9
10	9	5	0	5	0	0.0000	0.0000	10	9
11	9	5	3	2	0	0.6000	0.0000	11	9
1	10	1	0	1	1	0.0000	1.0000	1	10
3	10	6	0	6	0	0.0000	0.0000	3	10
4	10	3	0	3	0	0.0000	0.0000	4	10
5	10	7	0	7	0	0.0000	0.0000	5	10
6	10	3	0	3	0	0.0000	0.0000	6	10
7	10	2	0	2	0	0.0000	0.0000	7	10
8	10	6	0	6	0	0.0000	0.0000	8	10
9	10	5	3	2	0	0.6000	0.0000	9	10
1	11	9	3	6	0	0.3333	0.0000	1	11
2	11	1	1	0	0	1.0000	0.0000	2	11
3	11	6	1	5	1	0.1667	0.2000	3	11
4	11	3	2	1	0	0.6667	0.0000	4	11
5	11	2	0	2	0	0.0000	0.0000	5	11
6	11	2	0	2	0	0.0000	0.0000	6	11
9	11	2	2	0	0	1.0000	0.0000	9	11
10	11	1	0	1	0	0.0000	0.0000	10	11

Figure 1-20. Node Pair Statistics for SC1101 at 45 Minutes

***** 0:30: 0*****

NODE TO NODE ROUTING TABLE

NS	PTH	ND1S	ND2S	ND3S	ND4S	ND5S	ND6S	ND7S	ND8S	ND9S	ND10S	ND11S
1	1	0:0	2:0	3:0	3:0	5:0	2:0	3:0	8:0	2:0	5:0	5:0
	2	0:0	3:0	2:0	2:0	3:0	3:0	8:0	3:0	8:0	3:0	3:0
	3	0:0	5:0	8:0	8:0	2:0	8:0	2:0	2:0	5:0	8:0	2:0
	4	0:0	0:0	0:0	0:0	0:0	0:0	0:0	0:0	0:0	0:0	0:0
2	1	1:1	0:0	3:1	4:1	5:1	6:1	4:1	8:1	9:1	5:1	5:1
	2	3:1	0:0	6:1	3:1	3:1	0:0	3:1	6:1	4:1	3:1	6:1
	3	5:1	0:0	0:0	0:0	0:0	0:0	0:0	3:1	3:1	0:0	0:0
	4	0:0	0:0	0:0	0:0	0:0	0:0	0:0	0:0	0:0	0:0	0:0
3	1	1:0	2:1	0:0	4:1	5:1	6:1	7:1	8:1	5:1	10:1	5:1
	2	2:1	6:1	0:0	8:1	8:1	8:1	8:1	4:1	8:1	8:1	8:1
	3	8:1	0:0	0:0	0:0	0:0	0:0	0:0	0:0	2:1	0:0	0:0
	4	0:0	0:0	0:0	0:0	0:0	0:0	0:0	0:0	0:0	0:0	0:0
4	1	3:1	2:1	3:1	0:0	8:1	8:1	7:1	8:1	8:1	8:1	8:1
	2	2:1	3:1	8:1	0:0	3:1	2:1	8:1	7:1	3:1	3:1	3:1
	3	8:1	0:0	0:0	0:0	0:0	3:1	3:1	3:1	2:1	0:0	0:0
	4	0:0	0:0	0:0	0:0	0:0	0:0	0:0	0:0	0:0	0:0	0:0
5	1	1:1	2:1	3:1	8:1	0:0	8:1	8:1	8:1	9:1	10:1	11:1
	2	3:1	3:1	8:1	3:1	0:0	2:1	3:1	10:1	2:1	3:1	0:0
	3	2:1	0:0	0:0	0:0	0:0	3:1	0:0	3:1	8:1	0:0	0:0
	4	0:0	0:0	0:0	0:0	0:0	0:0	0:0	0:0	0:0	0:0	0:0
6	1	2:1	2:1	3:1	8:1	8:1	0:0	8:1	8:1	2:1	8:1	8:1
	2	3:1	0:0	8:1	2:1	2:1	0:0	3:1	3:1	8:1	3:1	2:1
	3	8:1	0:0	0:0	3:1	3:1	0:0	0:0	0:0	3:1	0:0	3:1
	4	0:0	0:0	0:0	0:0	0:0	0:0	0:0	0:0	0:0	0:0	0:0
7	1	3:1	4:1	3:1	4:1	8:0	8:0	0:0	8:1	8:0	8:0	8:0
	2	8:0	3:1	8:0	8:0	3:1	3:1	0:0	4:1	3:1	3:1	3:1
	3	0:0	0:0	0:0	3:1	0:0	0:0	0:0	3:1	0:0	0:0	0:0
	4	0:0	0:0	0:0	0:0	0:0	0:0	0:0	0:0	0:0	0:0	0:0
8	1	1:0	2:1	3:1	4:1	5:1	6:1	7:1	0:0	9:1	10:1	11:1
	2	3:1	6:1	4:1	3:1	10:1	2:1	4:1	0:0	5:1	3:1	10:1
	3	2:1	3:1	0:0	0:0	3:1	3:1	3:1	0:0	3:1	0:0	5:1
	4	0:0	0:0	0:0	0:0	0:0	0:0	0:0	0:0	0:0	0:0	0:0
9	1	2:1	2:1	8:1	8:1	5:1	2:1	8:1	8:1	0:0	5:0	5:0
	2	5:0	5:0	5:0	5:0	2:1	5:0	5:0	5:0	0:0	8:1	8:1
	3	0:0	0:0	2:1	2:1	0:0	0:0	2:1	2:1	0:0	2:1	0:0
	4	0:0	0:0	0:0	0:0	0:0	0:0	0:0	0:0	0:0	0:0	0:0
10	1	5:1	5:1	3:1	8:1	5:1	8:1	8:1	8:1	5:1	0:0	5:1
	2	3:1	3:1	8:1	3:1	3:1	3:1	3:1	3:1	8:1	0:0	8:1
	3	8:0	0:0	0:0	0:0	0:0	0:0	0:0	0:0	0:0	0:0	0:0
	4	0:0	0:0	0:0	0:0	0:0	0:0	0:0	0:0	0:0	0:0	0:0
11	1	5:0	5:0	8:1	8:1	5:1	5:0	8:1	8:1	5:0	5:0	0:0
	2	0:0	0:0	5:0	5:0	0:0	0:0	5:0	5:0	0:0	0:0	0:0
	3	0:0	0:0	0:0	0:0	0:0	0:0	0:0	0:0	0:0	0:0	0:0
	4	0:0	0:0	0:0	0:0	0:0	0:0	0:0	0:0	0:0	0:0	0:0

Figure 1-21. Nominal European Routing Plan

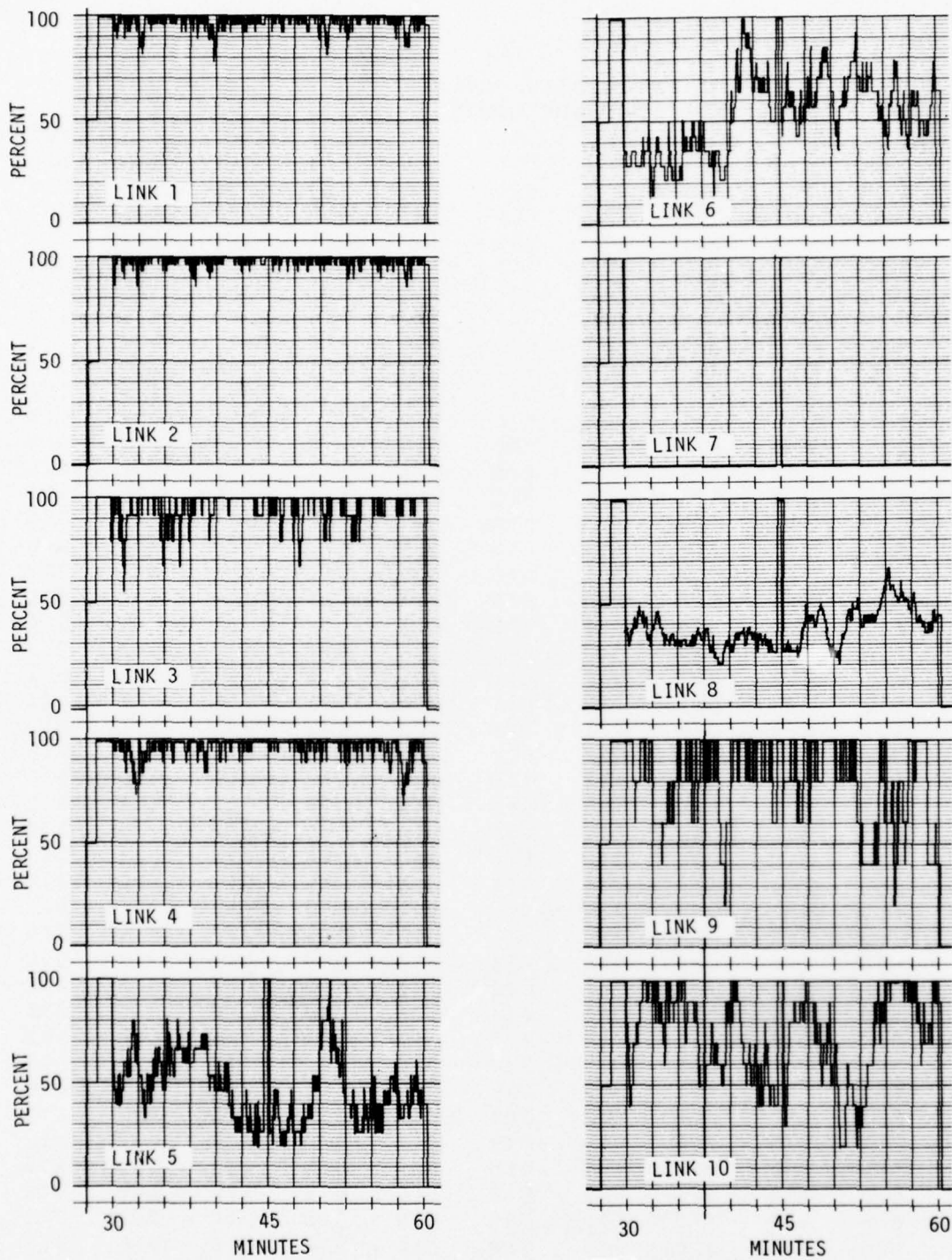

Figure 1-22. IST Percent Utilization with Routing Plan Update at 45 Minutes

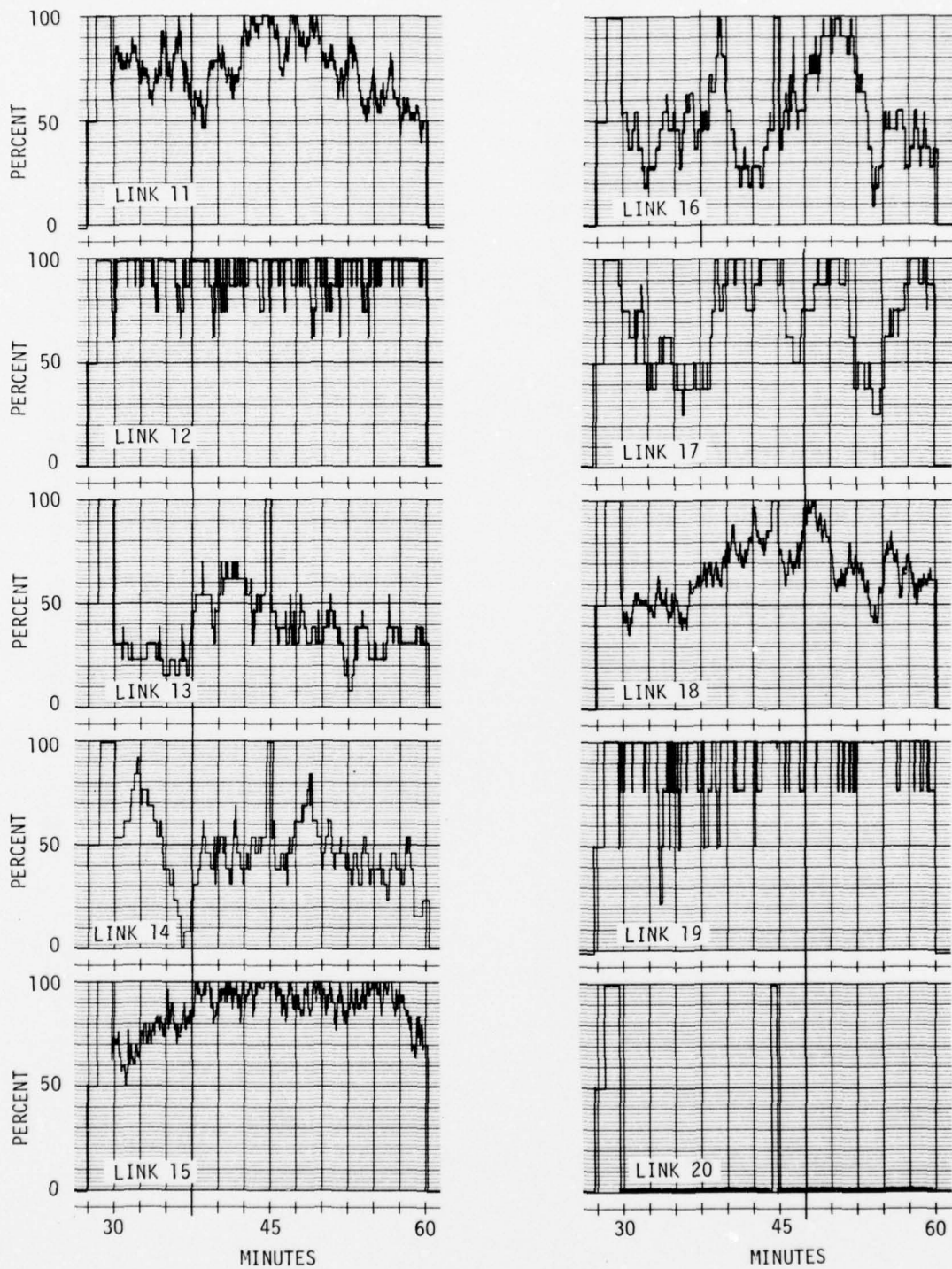

Figure 1-22. (Continued)

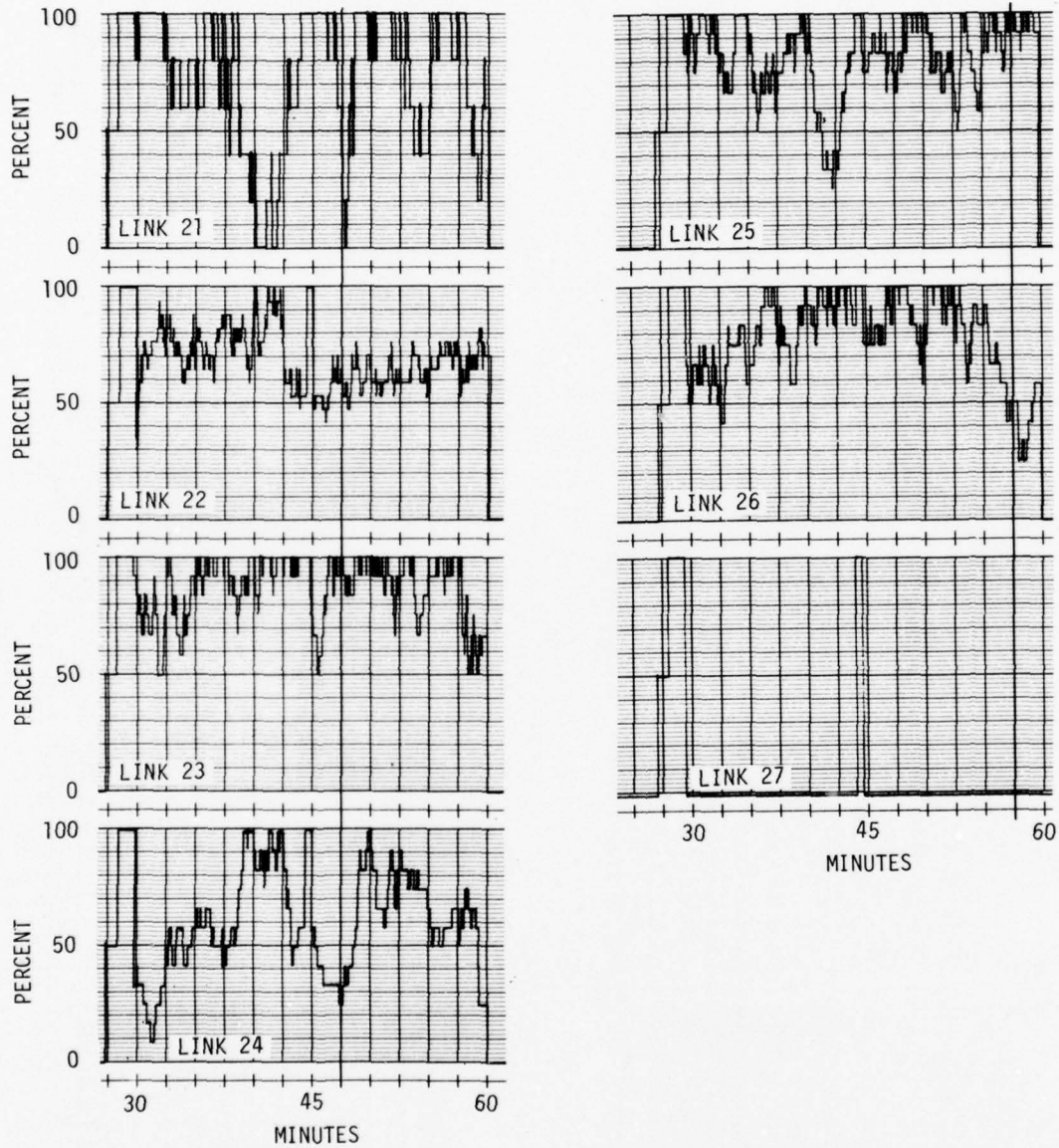

Figure 1-22. (Continued)

Although the change in overall network performance due to this control procedure is minimal, the procedure guarantees that all nodes have a valid path to all other nodes, ensuring the high priority caller accessibility to the entire network. Connectivity and valid routing tables should be the primary concern of the controller before addressing the problem of overall network performance. The grade of service or blocking probability before the control action was 0.1535 and after the control action was 0.1468. The resulting grades of service and node-to-node statistics after the control action are shown in Figures 1-23 and 1-24.

```

***** 1: 0: 0*****
*ACCUMULATED TOTAL NETWORK STATISTICS*
ATTEMPTS BLOCKS COMPLETE PREEMPTED BL/ATT PR/COM
1301      191      1110      153 0.1468 0.1378
***** 1: 0: 0*****
*ACCUMULATED NETWORK PRECEDENCE STATISTICS*
PREC ATTEMPTS BLOCKS COMPLETE PREEMPTED BL/ATT PR/COM PREC
0         0         0         0         0 0.0000 0.0000 0
1         3         0         3         0 0.0000 0.0000 1
2        381         4        377         0 0.0105 0.0000 2
3         80         0         80         1 0.0000 0.0125 3
4        837        187        650        152 0.2234 0.2338 4
***** 1: 0: 0*****
*ACCUMULATED LINK/PRIORITY GOS STATUS
LINK A      TOTAL          P0          P1          P2          P3          P4
BLCK/ATTM=X.XX BLCK/ATTM BLCK/ATTM BLCK/ATTM BLCK/ATTM BLCK/ATTM BLCK/ATTM
1**      262/ 438=0.60      0/ 0      1/ 3      124/ 241      0/ 0      137/ 194
2**      292/ 482=0.61      0/ 0      1/ 2      146/ 261      0/ 0      145/ 219
3**       88/ 156=0.56      0/ 0      0/ 0      51/ 93      0/ 0      37/ 63
4**      190/ 300=0.63      0/ 0      1/ 1      103/ 171      0/ 0      86/ 128
5         0/ 121=0.00      0/ 0      0/ 0      0/ 47      0/ 1      0/ 73
6         0/ 87=0.00      0/ 0      0/ 0      0/ 30      0/ 2      0/ 55
7***     110/ 110=1.00      0/ 0      0/ 0      51/ 51      4/ 4      55/ 55
8         0/ 106=0.00      0/ 0      0/ 1      0/ 37      0/ 3      0/ 65
9**       42/ 84=0.50      0/ 0      0/ 0      21/ 38      2/ 4      19/ 42
10        21/ 109=0.19      0/ 0      1/ 2      4/ 47      1/ 5      15/ 55
11         9/ 196=0.05      0/ 0      0/ 0      5/ 73      0/ 12      4/ 111
12**      95/ 152=0.63      0/ 0      0/ 0      33/ 51      5/ 9      57/ 92
13         0/ 43=0.00      0/ 0      0/ 0      0/ 12      0/ 2      0/ 29
14         0/ 43=0.00      0/ 0      0/ 0      0/ 8      0/ 3      0/ 32
15        27/ 247=0.11      0/ 0      0/ 0      5/ 76      3/ 16      19/ 155
16         2/ 51=0.04      0/ 0      0/ 0      0/ 9      0/ 8      2/ 34
17         6/ 30=0.20      0/ 0      0/ 0      0/ 2      1/ 4      5/ 24
18         3/ 176=0.02      0/ 0      0/ 0      0/ 30      1/ 18      2/ 128
19**      71/ 95=0.75      0/ 0      0/ 0      8/ 13      7/ 14      56/ 68
20***     71/ 71=1.00      0/ 0      1/ 1      22/ 22      9/ 9      39/ 39
21 *      18/ 54=0.33      0/ 0      0/ 0      2/ 7      5/ 8      11/ 39
22         0/ 94=0.00      0/ 0      0/ 0      0/ 36      0/ 6      0/ 52
23 *      31/ 101=0.31      0/ 0      0/ 0      3/ 12      3/ 9      25/ 80
24         2/ 39=0.05      0/ 0      0/ 0      0/ 5      0/ 4      2/ 30
25        21/ 85=0.25      0/ 0      0/ 0      1/ 9      4/ 18      16/ 58
26        11/ 64=0.17      0/ 0      0/ 0      3/ 9      0/ 7      8/ 48
27***     39/ 39=1.00      0/ 0      0/ 0      7/ 7      4/ 4      28/ 28

```

Figure 1-23. Network Precedence and Link Status for SC1101 with Routing Plan Change

***** 1: 0: 0*****

ACCUMULATED NODE TO NODE NETWORK STATISTICS

NODE	NODE	ATTEMPTS	BLOCKS	COMPLETE	PREEMPTED	BL/ATT	PR/COM	NODE	NODE
2	1	65	17	48	13	0.2615	0.2708	2	1
3	1	79	18	61	10	0.2278	0.1639	3	1
4	1	75	12	63	18	0.1600	0.2857	4	1
5	1	34	10	24	5	0.2941	0.2083	5	1
6	1	29	5	24	5	0.1724	0.2083	6	1
7	1	9	0	9	1	0.0000	0.1111	7	1
8	1	104	19	85	17	0.1827	0.2000	8	1
9	1	32	11	21	2	0.3437	0.0952	9	1
10	1	9	3	6	1	0.3333	0.1667	10	1
11	1	31	7	24	8	0.2258	0.3333	11	1
1	2	32	6	26	10	0.1875	0.3846	1	2
4	2	3	0	3	0	0.0000	0.0000	4	2
6	2	1	0	1	0	0.0000	0.0000	6	2
7	2	1	0	1	0	0.0000	0.0000	7	2
8	2	1	0	1	0	0.0000	0.0000	8	2
9	2	2	1	1	1	0.5000	1.0000	9	2
11	2	2	2	0	0	1.0000	0.0000	11	2
1	3	29	5	24	4	0.1724	0.1667	1	3
4	3	38	0	38	0	0.0000	0.0000	4	3
5	3	2	1	1	0	0.5000	0.0000	5	3
6	3	2	0	2	0	0.0000	0.0000	6	3
7	3	9	0	9	0	0.0000	0.0000	7	3
8	3	34	0	34	0	0.0000	0.0000	8	3
9	3	9	2	7	0	0.2222	0.0000	9	3
10	3	19	0	19	0	0.0000	0.0000	10	3
11	3	15	11	4	0	0.7333	0.0000	11	3
1	4	35	8	27	6	0.2286	0.2222	1	4
2	4	4	0	4	0	0.0000	0.0000	2	4
3	4	26	0	26	0	0.0000	0.0000	3	4
5	4	8	3	5	2	0.3750	0.4000	5	4
6	4	15	0	15	0	0.0000	0.0000	6	4
7	4	11	0	11	0	0.0000	0.0000	7	4
8	4	26	0	26	0	0.0000	0.0000	8	4
9	4	4	1	3	0	0.2500	0.0000	9	4
10	4	6	0	6	0	0.0000	0.0000	10	4
11	4	9	4	5	2	0.4444	0.4000	11	4
1	5	20	5	15	6	0.2500	0.4000	1	5
2	5	1	0	1	0	0.0000	0.0000	2	5
3	5	3	1	2	0	0.3333	0.0000	3	5
4	5	5	3	2	1	0.6000	0.5000	4	5
8	5	3	0	3	2	0.0000	0.6667	8	5
9	5	6	3	3	0	0.5000	0.0000	9	5
10	5	9	2	7	0	0.2222	0.0000	10	5
11	5	1	0	1	0	0.0000	0.0000	11	5
1	6	23	4	19	6	0.1739	0.3158	1	6
2	6	17	0	17	0	0.0000	0.0000	2	6
3	6	4	0	4	0	0.0000	0.0000	3	6
4	6	17	0	17	1	0.0000	0.0588	4	6
5	6	2	1	1	1	0.5000	1.0000	5	6
7	6	2	0	2	0	0.0000	0.0000	7	6
8	6	9	0	9	0	0.0000	0.0000	8	6
9	6	8	0	8	3	0.0000	0.3750	9	6
3	7	21	0	21	0	0.0000	0.0000	3	7
4	7	14	0	14	0	0.0000	0.0000	4	7
5	7	1	0	1	0	0.0000	0.0000	5	7
6	7	1	0	1	0	0.0000	0.0000	6	7
8	7	2	0	2	0	0.0000	0.0000	8	7
9	7	4	1	3	0	0.2500	0.0000	9	7
10	7	3	0	3	0	0.0000	0.0000	10	7
1	8	19	2	17	5	0.1053	0.2941	1	8
2	8	19	0	19	0	0.0000	0.0000	2	8
3	8	40	0	40	0	0.0000	0.0000	3	8
4	8	31	0	31	0	0.0000	0.0000	4	8
5	8	15	2	13	2	0.1333	0.1538	5	8
6	8	23	0	23	0	0.0000	0.0000	6	8
7	8	19	0	19	0	0.0000	0.0000	7	8
9	8	12	1	11	1	0.0833	0.0909	9	8
10	8	7	0	7	0	0.0000	0.0000	10	8
11	8	5	1	4	1	0.2000	0.2500	11	8
1	9	22	1	21	4	0.0455	0.1905	1	9
2	9	3	0	3	1	0.0000	0.3333	2	9
3	9	2	1	1	0	0.5000	0.0000	3	9
4	9	10	0	10	1	0.0000	0.1000	4	9
5	9	2	2	0	0	1.0000	0.0000	5	9
6	9	10	2	8	2	0.2000	0.2500	6	9
7	9	2	0	2	0	0.0000	0.0000	7	9
8	9	7	0	7	2	0.0000	0.2857	8	9
10	9	4	1	3	0	0.2500	0.0000	10	9
11	9	3	1	2	0	0.3333	0.0000	11	9
1	10	3	0	3	1	0.0000	0.3333	1	10
3	10	11	0	11	0	0.0000	0.0000	3	10
4	10	3	0	3	0	0.0000	0.0000	4	10
5	10	4	0	4	3	0.0000	0.7500	5	10
6	10	2	0	2	0	0.0000	0.0000	6	10
7	10	2	0	2	0	0.0000	0.0000	7	10
8	10	8	0	8	1	0.0000	0.1250	8	10
9	10	5	3	2	1	0.6000	0.5000	9	10
1	11	10	3	7	1	0.3000	0.1429	1	11
2	11	2	1	1	0	0.5000	0.0000	2	11
3	11	4	0	4	0	0.0000	0.0000	3	11
4	11	2	1	1	0	0.5000	0.0000	4	11
6	11	1	1	0	0	1.0000	0.0000	6	11
9	11	2	1	1	0	0.5000	0.0000	9	11
10	11	1	1	0	0	1.0000	0.0000	10	11

Figure 1-24. Node Pair Status for SC1101 with Routing Plan Change

Upon completion of these procedures, the controller should check common equipment usage to determine if excessive demand on this equipment exists. The stripplots showing the RSJ demand for each node indicate essentially no change from Figure 1-19. For this scenario, which does not include the intraswitch traffic, none of the nodes experience an abnormal demand for RSJs. If the demand were greater than normal, it would indicate inadequate Automatic Traffic Overload Protection and the controller would need to address the RSJ occupancy data base to identify those nodes with demands exceeding the common equipment capacities. He would need to call up node priority data that indicates blocking and preempting for each node and priority, and determine line load control percentages for the lower precedence callers. In addition, it may be necessary to access the traffic statistics data base to derive percentages for terminating, tandem, and originating traffic for possible directionalization of trunks from overload switches.

Once the system is reported back to normal, and the transmission link between Mt. Limbar and Mt. Vergine is back in service, the controller should remove all controls put in during the scenario sequence. Because of the complexity of some scenarios and their controls, it is evident that a controller aid is needed to record controller inputs so that the controller can retrace his activities and reduce the possibility of error when it comes time to remove control measures.

Additional reduction in network blocking probability can be achieved if some spare trunking can be made available. In the digital environment simulated, there is satellite capability (DSCS III) at 5 of the 10 nodes of AUTOVON. For this study it was assumed that some of this capability could be reallocated to the voice network for relieving congestion brought on by the loss of transmission between Mr. Limbar and Mt. Vergine. Figure 1-15 illustrates the network connectivity with placement of satellite earth stations. The additional capacity allocated by the controller in this example was:

Link	From	To	Added Capacity	Resultant Capacity
9	HIN	DON	2	7
10	HIN	HUM	2	12
19	DON	MTV	2	6
20	HUM	MTV	9	9
21	MTV	CTO	2	7
25	DON	HUM	2	14
26	DON	CTO	2	14

The combined network performance improvement of this reallocation and routing plan change is shown in Figure 1-25. The change in link blocking probabilities is also illustrated. If spare satellite or microwave transmission resources are available, they should be reallocated to other links until the link blocking probability has been reduced to 0.01 or to the designed blocking probability.

```

***** 1: 0: 0*****
*ACCUMULATED TOTAL NETWORK STATISTICS*
ATTEMPTS BLOCKS COMPLETE PREEMPTED BL/ATT PR/COM
1305 161 1144 132 0.1234 0.1154
***** 1: 0: 0*****
*ACCUMULATED NETWORK PRECEDENCE STATISTICS*
PREC ATTEMPTS BLOCKS COMPLETE PREEMPTED BL/ATT PR/COM PREC
0 0 0 0 0 0.0000 0.0000 0
1 3 0 3 0 0.0000 0.0000 1
2 381 0 381 0 0.0000 0.0000 2
3 80 0 80 0 0.0000 0.0000 3
4 841 161 680 132 0.1914 0.1941 4
***** 1: 0: 0*****
*ACCUMULATED LINK/PRIORITY GOS STATUS
LINK A TOTAL P0 P1 P2 P3 P4
BLCK/ATTM=X.XX BLCK/ATTM BLCK/ATTM BLCK/ATTM BLCK/ATTM BLCK/ATTM
1** 288/ 458=0.63 0/ 0 2/ 4 143/ 249 0/ 0 143/ 205
2** 310/ 485=0.64 0/ 0 1/ 2 155/ 264 0/ 0 154/ 219
3** 113/ 187=0.60 0/ 0 1/ 1 59/ 110 0/ 0 53/ 76
4** 171/ 295=0.58 0/ 0 1/ 1 91/ 170 0/ 0 79/ 124
5 0/ 115=0.00 0/ 0 0/ 0 0/ 48 0/ 0 0/ 67
6 3/ 81=0.04 0/ 0 0/ 0 1/ 33 0/ 2 2/ 46
7*** 106/ 106=1.00 0/ 0 1/ 1 50/ 50 1/ 1 54/ 54
8 0/ 107=0.00 0/ 0 0/ 1 0/ 39 0/ 2 0/ 65
9 17/ 82=0.21 0/ 0 0/ 0 8/ 32 1/ 4 8/ 46
10 6/ 75=0.08 0/ 0 0/ 2 3/ 53 0/ 1 3/ 39
11 11/ 198=0.06 0/ 0 0/ 0 5/ 74 0/ 12 6/ 112
12** 75/ 145=0.52 0/ 0 1/ 1 25/ 49 3/ 4 46/ 91
13 0/ 44=0.00 0/ 0 0/ 0 0/ 16 0/ 3 0/ 25
14 0/ 42=0.00 0/ 0 0/ 0 0/ 8 0/ 3 0/ 31
15 38/ 229=0.17 0/ 0 0/ 0 11/ 70 3/ 13 24/ 146
16 1/ 45=0.02 0/ 0 0/ 0 0/ 8 0/ 7 1/ 30
17 1/ 27=0.04 0/ 0 0/ 0 0/ 2 0/ 4 1/ 21
18 9/ 194=0.05 0/ 0 0/ 0 1/ 33 0/ 19 8/ 142
19 * 32/ 68=0.47 0/ 0 0/ 0 1/ 7 4/ 9 27/ 52
20 6/ 61=0.10 0/ 0 0/ 1 3/ 19 1/ 5 2/ 36
21 10/ 46=0.22 0/ 0 0/ 0 0/ 4 1/ 7 9/ 35
22 0/ 92=0.00 0/ 0 0/ 0 0/ 34 0/ 6 0/ 52
23 * 31/ 102=0.30 0/ 0 0/ 0 3/ 17 4/ 9 24/ 76
24 0/ 40=0.00 0/ 0 0/ 0 0/ 6 0/ 3 0/ 31
25 4/ 58=0.07 0/ 0 0/ 0 1/ 9 0/ 10 3/ 39
26 2/ 45=0.04 0/ 0 0/ 0 1/ 6 0/ 4 1/ 35
27*** 37/ 37=1.00 0/ 0 0/ 0 3/ 3 4/ 4 30/ 30

```

Figure 1-25. Network Precedence and Link Status for SC1101 with Composite Control

1.3.3 Scenario - SC1112A/C Transmission Loss in Germany

The heaviest traffic area in the European AUTOVON is the German area, which includes the switch and trunk groups associated with Feldberg, Donnersberg, Schoenfeld, and Langerkopf. To analyze the control strategy for a loss of resources in this area, a perturbation scenario that causes the loss of all transmission capability over the largest link in Germany connecting two major nodes was simulated. In this simulation the transmission link between Feldberg-Rheinmain-Donnersberg (Figure 1-16) has been removed from service. This link affects 47 node-to-node circuits, which include HIN-DON (loss of all circuits), LKF-SCH (loss of all circuits), DON-MTV (loss of 1 circuit), SCH-DON (loss of 10 circuits), and DON-MTP (loss of 1 circuit).

This scenario begins with an ATEC report from the German area sector control reporting that the digital microwave link between Feldberg-Rheinmain-Donnersberg has failed and is completely out of service. Upon receiving this report the controller should enter this change in resources into the network connectivity plot program, which will indicate the complete loss of any node-to-node connectivity due to the transmission loss. The output for this scenario is shown in Figure 1-26. The controller can by inspection see that no node has been completely isolated because of the loss of links between HIN-DON and DON-FEL. The only other isolation that can occur must be the result of an inadequate routing plan. The controller can determine if this possibility exists by using the routing plan verifier controller aid to search the plan for node-to-node isolation. Results of this action demonstrate that the routing plan still provides a path for each node to every other node. A call up of network blocking probability prior to and after the reported loss shows that considerable blocking has resulted from this transmission loss. The blocking probability for the 15 minutes before the loss was 0.0906 with a probability of preemption equal to 0.0970. For the 15 minutes after the loss the blocking probability has climbed to 0.1375 with a probability of preemption equal to 0.1054. Because of preemption the majority of blocking is at the routine call level. Figure 1-27 presents the network and precedence status prior to (30 minutes) and after (45 minutes) the perturbation.

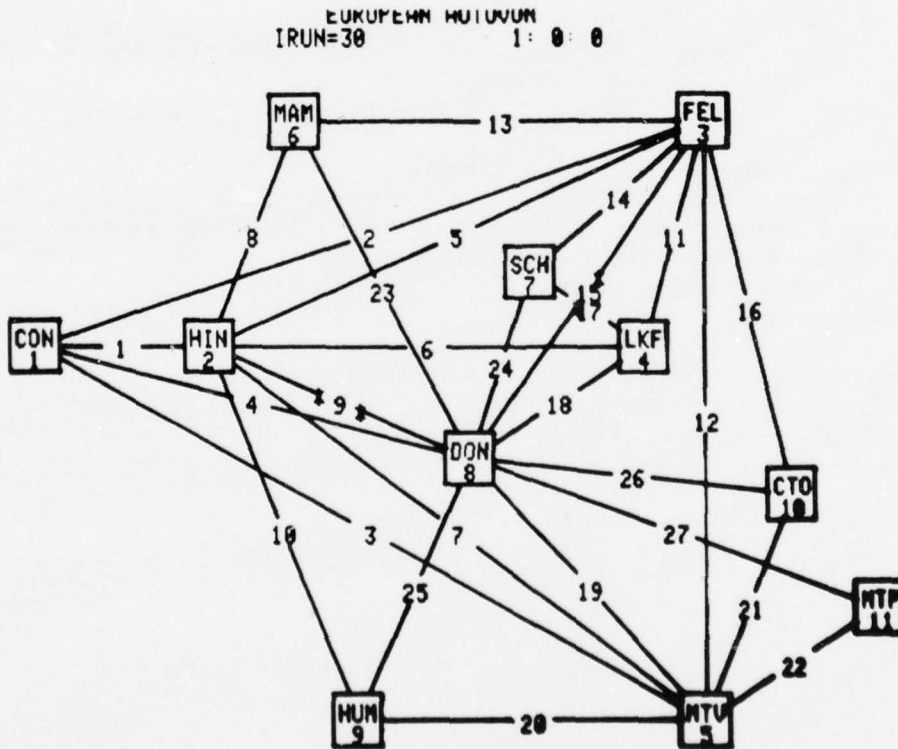

Figure 1-26. Network Connectivity Resulting from SC1112

```

***** 0:30: 0*****
*ACCUMULATED TOTAL NETWORK STATISTICS*
ATTEMPTS BLOCKS COMPLETE PREEMPTED BL/ATT PR/COM
1281 116 1165 113 0.0906 0.0970
***** 0:30: 0*****
*ACCUMULATED NETWORK PRECEDENCE STATISTICS*
PREC ATTEMPTS BLOCKS COMPLETE PREEMPTED BL/ATT PR/COM PREC
0 0 0 0 0 0.0000 0.0000 0
1 2 0 2 0 0.0000 0.0000 1
2 378 3 375 1 0.0079 0.0027 2
3 77 0 77 0 0.0000 0.0000 3
4 824 113 711 112 0.1371 0.1575 4

***** 0:45: 0*****
*ACCUMULATED TOTAL NETWORK STATISTICS*
ATTEMPTS BLOCKS COMPLETE PREEMPTED BL/ATT PR/COM
1287 177 1110 117 0.1375 0.1054
***** 0:45: 0*****
*ACCUMULATED NETWORK PRECEDENCE STATISTICS*
PREC ATTEMPTS BLOCKS COMPLETE PREEMPTED BL/ATT PR/COM PREC
0 0 0 0 0 0.0000 0.0000 0
1 2 0 2 0 0.0000 0.0000 1
2 373 1 372 0 0.0027 0.0000 2
3 71 0 71 1 0.0000 0.0141 3
4 841 176 665 116 0.2093 0.1744 4

```

Figure 1-27. Network and Precedence Status Prior to and Following Perturbation for SC1112

Since the configuration of the network has been changed by the perturbation, the controller should assess the resulting traffic distribution for remaining trunk groups. With this scenario there has resulted significant increases in blocking probability on links. The first attempt to relieve this blocking was a routing plan change for all primary paths using heavily blocked trunk groups.

By calling up the 15 minute accumulated blocking statistics for the remaining links in the network, a quick assessment of those trunks with heavy blocking can be made (Figure 1-28). For this scenario the heaviest blocking occurs on trunk groups within the German area. These links are:

Link	Node - Node	Blocking Probability
10	HIN - HUM	0.17
11	FEL - LKF	0.29
14	FEL - SCH	0.18
17	LKF - SCH	0.20
18	DON - LKF	0.15
23	DON - MAM	0.28
24	DON - SCH	0.75

***** 0:45: 0*****

*ACCUMULATED LINK/PRIORITY GOS STATUS

LINK A	TOTAL		P0		P1		P2		P3		P4	
	BLCK/	ATTM=X,XX	BLCK/	ATTM	BLCK/	ATTM	BLCK/	ATTM	BLCK/	ATTM	BLCK/	ATTM
1**	246/	398=0.62	0/	0	1/	1	134/	233	0/	0	111/	164
2**	243/	442=0.55	0/	0	1/	3	139/	265	0/	0	103/	174
3**	118/	174=0.68	0/	0	0/	0	70/	105	0/	0	48/	69
4 *	118/	240=0.49	0/	0	1/	1	58/	131	0/	0	59/	108
5	0/	95=0.00	0/	0	0/	0	0/	52	0/	0	0/	43
6	0/	77=0.00	0/	0	0/	0	0/	43	0/	1	0/	33
7	2/	74=0.03	0/	0	0/	0	1/	43	0/	0	1/	31
8	0/	92=0.00	0/	0	0/	0	0/	34	0/	2	0/	56
9***	69/	69=1.00	0/	0	0/	0	26/	26	0/	0	43/	43
10	0/	48=0.00	0/	0	0/	0	0/	19	0/	2	0/	27
11	51/	288=0.18	0/	0	0/	0	15/	87	5/	24	31/	177
12	0/	115=0.00	0/	0	0/	0	0/	51	0/	4	0/	60
13	0/	41=0.00	0/	0	0/	0	0/	10	0/	0	0/	31
14	5/	64=0.08	0/	0	0/	0	1/	9	1/	7	3/	48
15***	258/	258=1.00	0/	0	0/	0	54/	54	20/	20	184/	184
16	0/	39=0.00	0/	0	0/	0	0/	6	0/	5	0/	28
17 *	16/	52=0.31	0/	0	0/	0	1/	4	3/	7	12/	41
18	42/	292=0.14	0/	0	0/	0	8/	51	2/	31	32/	210
19	0/	35=0.00	0/	0	0/	0	0/	1	0/	3	0/	31
20	0/	55=0.00	0/	0	0/	0	0/	12	0/	4	0/	39
21	0/	29=0.00	0/	0	0/	0	0/	5	0/	6	0/	18
22	0/	88=0.00	0/	0	0/	0	0/	28	0/	7	0/	53
23 *	30/	92=0.33	0/	0	0/	0	5/	17	0/	1	25/	74
24***	49/	62=0.79	0/	0	0/	0	2/	4	7/	11	40/	47
25	2/	63=0.03	0/	0	0/	0	0/	8	0/	3	2/	52
26	0/	41=0.00	0/	0	0/	0	0/	4	0/	5	0/	32
27	2/	40=0.05	0/	0	0/	0	0/	0	0/	4	2/	36

Figure 1-28. Link Status Following Perturbation for SC1112

The routing plan change for this control action was accomplished semiautomatically by calling up the current routing plan from the ACOC data base and with a copy of the network connectivity identifying by inspection those call combinations that affect the blocking probabilities of the above links. New routes for these combinations were selected using trunk groups that show very little or no blocking. The new routes were:

NS	ND	NT1:S	NT2:S	NT3:S	NT4:S
HIN	DON	HUM:1	DON:1	MTV:1	FEL:1
FEL	DON	MTV:1	CTO:1	DON:1	LKF:1
FEL	CTO	CTO:1	MTV:1	DON:1	0:0
MAM	DON	HIN:1	DON:1	FEL:1	0:0
DON	HIN	HIN:1	HUM:1	MAM:1	FEL:1
DON	FEL	MTV:1	CTO:1	FEL:1	LKF:1
DON	MAM	HUM:1	HIN:1	MAM:1	FEL:1
CTO	FEL	FEL:1	DON:1	MTV:1	0:0

Before directing these node pairs to change their respective routing tables, the routing plan verifier controller aid was called to determine if any node pair was isolated, or if loop back or spill forward entrapment could occur. For this case the routing plan verifier identified that routes spilling to MTV in routing to FEL have loop back. An inspection of the routing plan

indicated that the primary and secondary routes for node pairs FEL-DON and DON-FEL should be interchanged to correct this problem. The resulting changes were:

NS	ND	NT1:S	NT2:S	NT3:S	NT4:S
FEL	DON	CTO:1	MTV:1	DON:1	LKF:1
DON	FEL	CTO:1	MTV:1	FEL:1	LKF:1

The improvement in network performance for this one control action was insignificant by itself. The resulting call blocking probabilities with and without the control procedure were:

	With	Without
Total Network	0.1525	0.1554
PREC 0	0.0000	0.0000
PREC 1	0.0000	0.0000
PREC 2	0.0106	0.0026
PREC 3	0.0000	0.0000
PREC 4	0.2321	0.2401

It may appear that this action was not worthwhile, but as demonstrated later the combined effect of this routing plan change and DSCS satellite reallocation provides significant improvements in the blocking probability, while individually neither was significant.

The next attempt to improve network performance used the capability of DCSC III real-time adaptive control (RTAC) to reallocate satellite circuits to the AUTOVON network, wherever possible. Satellite terminals at HIN, HUM, CTO, DON, and MTV were used to allocate capacity to AUTOVON links:

Link	Before	After
HIN-HUM 10	10	15
HIN-DON 9	0	5
HIN-MTV 7	7	10
HUM-DON 25	12	18
DON-MTV 19	14	21
DON-CTO 26	12	18
HUM-MTV 20	18	27
CTO-MTV 21	9	14

Link 9, HIN-DON, was increased from zero to its former capacity of five; the other link capacity changes were approximately 50 percent. This was an arbitrary judgment on the part of the system controller at the ACOC and as demonstrated later this percentage is reasonable with the exception of links 20, 21, and 26, which did not require as great an increase as the others.

The resulting performance improvement was 0.0054 without routing plan change. Caller statistics for the reallocation procedure were:

ACCUMULATED TOTAL NETWORK STATISTICS
 ATTEMPTS BLOCKS COMPLETE PREEMPTED BL/ATT PR/COM
 1300 195 1105 143 0.1500 0.1294
 ***** 1: 0: 0*****

ACCUMULATED NETWORK PRECEDENCE STATISTICS
 PREC ATTEMPTS BLOCKS COMPLETE PREEMPTED BL/ATT PR/COM PREC
 0 0 0 0 0 0.0000 0.0000 0
 1 3 0 3 0 0.0000 0.0000 1
 2 380 0 380 1 0.0000 0.0026 2
 3 79 0 79 1 0.0000 0.0127 3
 4 838 195 643 141 0.2327 0.2193 4

The final control procedure for this perturbation scenario was the combination of routing plan change and satellite reallocation. The network connectivity plot illustrates the loss of trunk groups, and the link blocking data base or utilization stripplot show congestion. From these aids the controller can determine the area to reallocate circuits and the area to reroute traffic for maintaining acceptable performance within the network and especially in the congested areas resulting from the perturbation.

The combination of the two control procedures discussed above did provide a significant improvement in network performance. Overall network improvement was 0.0238 or 2.38 percent. Call statistics for the total network, all precedences with this control were:

ACCUMULATED TOTAL NETWORK STATISTICS
 ATTEMPTS BLOCKS COMPLETE PREEMPTED BL/ATT PR/COM
 1229 171 1128 122 0.1316 0.1082
 ***** 1: 0: 0*****

ACCUMULATED NETWORK PRECEDENCE STATISTICS
 PREC ATTEMPTS BLOCKS COMPLETE PREEMPTED BL/ATT PR/COM PREC
 0 0 0 0 0 0.0000 0.0000 0
 1 3 0 3 0 0.0000 0.0000 1
 2 380 0 380 1 0.0000 0.0026 2
 3 80 0 80 0 0.0000 0.0000 3
 4 836 171 665 121 0.2045 0.1820 4

More significant is the improvement of node-pair service in the German region.

This scenario indicates both the need for controller training using both real-time and faster than real-time simulations of the DCS to learn procedures such as those reported and also expected responses to these procedures. In addition to training, the faster than real-time simulator could provide the controller an aid with which ACOC real network parameters could be input with the intended procedures to determine the network response before directing an action that may degrade performance rather than improve it. In the case above, neither procedure alone had any significant effect

on the network, and the controller may not have tried both in a real situation for fear of the unknown. Yet, with a fast simulator an assessment of control combinations like those reported on could have been accomplished in a matter of minutes, giving the controller a higher level of confidence that the control procedure and actions would be beneficial.

1.3.4 Scenario SC1315A/C - Multiple Transmission Path Failure

This scenario simulates the failure of the three largest transmission links in the European theater. These are the paths from the Mt. Vergine (MTV) to Mt. Limbar (59 circuits), Coltano (CTO) to Mt. Limbar (48 circuits), and Donnersberg (DON) to Feldberg (FEL) (47 circuits). Several node pairs are isolated as a result of this stress, although physical connectivity is not destroyed. The primary control options include rerouting to restore logical connectivity and the employment of spare or available circuits. The complexity of real-time routing plan design and the corresponding need of on-line routing plan aids are demonstrated. The potential effectiveness of Real Time Adaptive Control (RTAC) of Defense Satellite Communication Systems (DSCS) resources in helping reduce the effect of temporary facility loss is also demonstrated.

Basic scenario SC1300 (the recall traffic model) was employed as the carrier of this simulation exercise. The perturbation occurs at 30 minutes with loss of carrier on the three largest transmission links in Europe. The resultant loss of logical link capacity is:

Link	From	To	Original Circuits	Lost Circuits	Resultant Circuits
9	HIN	DON	5	5	0
15	FEL	DON	30	30	0
19	MTV	DON	15	11	4
24	SCH	DON	12	10	2
27	DON	MTV	7	7	0
10	HIN	HUM	10	2	8
12	FEL	MTV	20	12	8
21	MTV	CTO	9	4	5
25	DON	HUM	12	12	0
7	HIN	MTV	7	7	0
20	MTV	HUM	18	18	0

The routing plan verifier is invoked in response to the ATEC report of the transmission failure. The isolated node pairs are:

HIN-MTP	DON-HUM	MTP-HUM
MTV-HUM	HUM-MTV	HUM-MTP
SCH-HUM	HUM-DON	CTO-HUM
	HUM-CTO	

Primary responsibility is to restore the logical connectivity to allow service to at least the high precedence subscribers. Note that network GOS at time = 45 minutes (15 minutes following the perturbation) is about 35 percent, with values of about 9, 21, and 45 percent for precedence levels immediate, priority, and routine. Overall network GOS rises to about 45 percent blockage at time = 1 hour with no control action taken. Figures 1-29 through 1-31 illustrate network status for the uncontrolled network for the 45 to 60 minute interval. Network, originating node, and links are presented.

The initial attempt to restore connectivity resulted in the following routing plan revision.

HUM TO MTV	MTV:1	HIN:0		
DON TO HUM	MAM:1	HUM:1	MTV:1	FEL:1
HUM TO DON	DON:1	MTV:0	HIN:1	
HUM TO CTO	MTV:0	DON:1	HIN:0	
HUM TO MTV	MTP:0	DON:1	HIN:1	
HIN TO MTV	MTP:1	MAM:1	FEL:1	

The revised routing plan was implemented and resulted in significant improvement of precedence level two service. Subsequently, an interim version of the routing plan verifier was implemented, and the resultant routing plan was tested. The routing plan verifier verified that no isolated node pairs existed. It also pointed out all partial paths that might be attempted with no change of success (wasted use of common equipment and transmission capacity) and demonstrated that one loopback path occurred. The table for HIN (2) to HUM (9) was subsequently reduced to the single tenable path, which is the direct path to HUM, removing the potential loopback problem. The resulting routing plan revision is:

HUM TO MTV	MTV:1	HIN:0		
DON TO HUM	MAM:1	HUM:1	MTV:1	FEL:1
HUM TO DON	DON:1	MTV:0	HIN:0	
HUM TO CTO	MTV:0	DON:1	HIN:0	
HUM TO MTV	MTP:0	DON:1	HIN:1	
HIN TO MTV	MTP:1	MAM:1	FEL:1	
HIN TO HUM	HUM:1			

The network, originating node, and link statistics resulting from this revision at t=60 minutes are presented in Figures 1-32 through 1-34. The overall network GOS remains about the same, but immediate and priority blockage is reduced to about 0.5 and 7 percent, respectively, demonstrating priority service reconstitution.

```

***** 1: 0: 0*****
*ACCUMULATED TOTAL NETWORK STATISTICS*
ATTEMPTS BLOCKS COMPLETE PREEMPTED BL/ATT PR/COM
1940      885      1055      173 0.4562 0.1640
***** 1: 0: 0*****
*ACCUMULATED NETWORK PRECEDENCE STATISTICS*
PREC ATTEMPTS BLOCKS COMPLETE PREEMPTED BL/ATT PR/COM PREC
0         0         0         0         0 0.0000 0.0000 0
1         2         0         2         0 0.0000 0.0000 1
2        341        30        311        0 0.0880 0.0000 2
3         94        19         75         4 0.2021 0.0533 3
4       1503       836       667       169 0.5562 0.2534 4

```

Figure 1-29. Network and Precedence Status for SC1315 at 60 Minutes

```

***** 1: 0: 0*****
*ACCUMULATED SOURCE NODE NETWORK STATISTICS*
NODE ATTEMPTS BLOCKS COMPLETE PREEMPTED BL/ATT PR/COM NODE
1      193      45      148      25 0.2332 0.1689 1
2      120      22       98       5 0.1833 0.0510 2
3      282     116     166     27 0.4113 0.1627 3
4      221      71     150     14 0.3213 0.0933 4
5      125      66      59     12 0.5280 0.2034 5
6      120      41      79     17 0.3417 0.2152 6
7       86      35      51      6 0.4070 0.1176 7
8      288     127     161     22 0.4410 0.1366 8
9      242     200      42     23 0.8264 0.5476 9
10     106      57      49      7 0.5377 0.1429 10
11     157     105      52     15 0.6688 0.2885 11

```

Figure 1-30. Source Node Statistics for SC1315 at 60 Minutes

```

***** 1: 0: 0*****
*ACCUMULATED LINK/PRIORITY GOS STATUS
LINK A TOTAL P0 P1 P2 P3 P4
BLCK/ATTM=X.XX BLCK/ATTM BLCK/ATTM BLCK/ATTM BLCK/ATTM BLCK/ATTM
1 * 147/ 322=0.46 0/ 0 1/ 2 66/ 161 0/ 0 80/ 159
2 * 95/ 290=0.33 0/ 0 2/ 3 42/ 150 0/ 0 51/ 137
3** 99/ 156=0.63 0/ 0 0/ 0 31/ 60 0/ 0 68/ 96
4 * 105/ 241=0.44 0/ 0 0/ 0 47/ 117 0/ 0 58/ 124
5 0/ 95=0.00 0/ 0 0/ 2 0/ 40 0/ 3 0/ 50
6 * 52/ 145=0.36 0/ 0 0/ 0 11/ 44 0/ 2 41/ 99
7*** 190/ 190=1.00 0/ 0 0/ 0 57/ 57 2/ 2 131/ 131
8 0/ 172=0.00 0/ 0 0/ 0 0/ 34 0/ 14 0/ 124
9*** 159/ 159=1.00 0/ 0 0/ 0 46/ 46 19/ 19 94/ 94
10 * 155/ 329=0.47 0/ 0 0/ 0 23/ 76 13/ 30 119/ 223
11** 302/ 499=0.61 0/ 0 0/ 0 46/ 85 12/ 27 244/ 387
12*** 205/ 272=0.75 0/ 0 0/ 0 30/ 48 13/ 20 162/ 204
13 0/ 72=0.00 0/ 0 0/ 0 0/ 11 0/ 4 0/ 57
14 8/ 86=0.09 0/ 0 0/ 0 1/ 16 1/ 11 6/ 59
15*** 524/ 524=1.00 0/ 0 1/ 1 84/ 84 35/ 35 404/ 404
16 0/ 51=0.00 0/ 0 0/ 0 0/ 3 0/ 5 0/ 43
17 * 17/ 51=0.33 0/ 0 0/ 0 0/ 3 4/ 9 13/ 39
18 42/ 376=0.11 0/ 0 0/ 0 2/ 39 3/ 34 37/ 303
19** 140/ 232=0.60 0/ 0 0/ 0 6/ 32 6/ 20 128/ 180
20*** 377/ 377=1.00 0/ 0 0/ 0 72/ 72 42/ 42 263/ 263
21 * 59/ 122=0.48 0/ 0 0/ 0 2/ 5 5/ 16 52/ 101
22 15/ 199=0.08 0/ 0 0/ 0 3/ 37 0/ 14 12/ 148
23 * 78/ 172=0.45 0/ 0 0/ 0 11/ 23 2/ 16 65/ 133
24*** 65/ 83=0.78 0/ 0 0/ 0 6/ 9 7/ 11 52/ 63
25*** 307/ 307=1.00 0/ 0 0/ 0 49/ 49 41/ 41 217/ 217
26 13/ 111=0.12 0/ 0 0/ 0 0/ 2 0/ 16 13/ 93
27*** 95/ 95=1.00 0/ 0 0/ 0 12/ 12 9/ 9 74/ 74

```

Figure 1-31. Link Status for SC1315 at 60 Minutes

```

***** 1: 0: 0*****
*ACCUMULATED TOTAL NETWORK STATISTICS*
ATTEMPTS BLOCKS COMPLETE PREEMPTED BL/ATT PR/COM
1914      850      1064      162 0.4441 0.1523
***** 1: 0: 0*****
*ACCUMULATED NETWORK PRECEDENCE STATISTICS*
PREC ATTEMPTS BLOCKS COMPLETE PREEMPTED BL/ATT PR/COM PREC
0      0      0      0      0 0.0000 0.0000 0
1      2      0      2      0 0.0000 0.0000 1
2     318      1     317      0 0.0031 0.0000 2
3      88      6      82      6 0.0682 0.0732 3
4     1506     843     663     156 0.5598 0.2353 4

```

Figure 1-32. Network and Precedence Status for SC1315 with Routing Revision

```

***** 1: 0: 0*****
*ACCUMULATED SOURCE NODE NETWORK STATISTICS*
NODE ATTEMPTS BLOCKS COMPLETE PREEMPTED BL/ATT PR/COM NODE
1      171      18     153     18 0.1053 0.1176 1
2      119      24      95      9 0.2017 0.0947 2
3      256      85     171     19 0.3320 0.1111 3
4      215      62     153     23 0.2884 0.1503 4
5      114      58      56     10 0.5088 0.1786 5
6      124      51      73     12 0.4113 0.1644 6
7       81      28      53      2 0.3457 0.0377 7
8      253      90     163     24 0.3557 0.1472 8
9      295     247      48     23 0.8373 0.4792 9
10     114      64      50      8 0.5614 0.1600 10
11     172     123      49     14 0.7151 0.2857 11

```

Figure 1-33. Source Node Statistics for SC1315 with Routing Revision

```

***** 1: 0: 0*****
*ACCUMULATED LINK/PRIORITY GOS STATUS
LINK A TOTAL P0 P1 P2 P3 P4
BLCK/ATTM=X,XX BLCK/ATTM BLCK/ATTM BLCK/ATTM BLCK/ATTM BLCK/ATTM
1 * 99/ 276=0.36 0/ 0 0/ 0 44/ 144 0/ 0 55/ 132
2 * 85/ 274=0.31 0/ 0 0/ 2 42/ 139 0/ 0 43/ 133
3** 61/ 120=0.51 0/ 0 0/ 0 24/ 57 0/ 0 37/ 63
4 * 73/ 201=0.36 0/ 0 0/ 0 37/ 104 0/ 0 36/ 97
5 0/ 100=0.00 0/ 0 0/ 0 0/ 38 0/ 4 0/ 58
6 23/ 116=0.20 0/ 0 0/ 0 9/ 40 1/ 4 13/ 72
7*** 128/ 128=1.00 0/ 0 0/ 0 32/ 32 2/ 2 94/ 94
8 0/ 206=0.00 0/ 0 0/ 0 0/ 38 0/ 25 0/ 143
9*** 102/ 102=1.00 0/ 0 0/ 0 27/ 27 11/ 11 64/ 64
10*** 328/ 414=0.79 0/ 0 0/ 0 26/ 59 16/ 27 286/ 328
11 * 205/ 437=0.47 0/ 0 0/ 0 36/ 78 11/ 28 158/ 331
12*** 220/ 280=0.79 0/ 0 0/ 0 23/ 38 14/ 21 183/ 221
13 0/ 82=0.00 0/ 0 0/ 0 0/ 7 0/ 8 0/ 67
14 2/ 74=0.03 0/ 0 0/ 0 0/ 14 0/ 6 2/ 54
15*** 427/ 427=1.00 0/ 0 0/ 0 61/ 61 30/ 30 336/ 336
16 9/ 70=0.13 0/ 0 0/ 0 0/ 2 0/ 5 9/ 63
17 7/ 48=0.15 0/ 0 0/ 0 0/ 3 1/ 7 6/ 38
18 36/ 328=0.11 0/ 0 0/ 0 5/ 31 4/ 32 27/ 265
19** 151/ 210=0.72 0/ 0 0/ 0 12/ 18 7/ 17 132/ 175
20*** 380/ 380=1.00 0/ 0 0/ 0 29/ 29 20/ 20 331/ 331
21** 66/ 124=0.53 0/ 0 0/ 0 1/ 5 2/ 5 63/ 114
22 42/ 219=0.19 0/ 0 0/ 0 5/ 34 0/ 13 37/ 172
23** 146/ 277=0.53 0/ 0 0/ 0 10/ 32 9/ 31 127/ 214
24*** 57/ 68=0.84 0/ 0 0/ 0 5/ 8 3/ 5 49/ 55
25*** 176/ 176=1.00 0/ 0 0/ 0 15/ 15 13/ 13 148/ 148
26 * 57/ 126=0.45 0/ 0 0/ 0 1/ 2 0/ 4 56/ 120
27*** 122/ 122=1.00 0/ 0 0/ 0 11/ 11 7/ 7 104/ 104

```

Figure 1-34. Link Status for SC1315 with Routing Revision

If satellite capacity is available to provide even minimal replacement of lost facilities, precedence and immediate level service can be even more significantly improved with the following assignment of 11 voice channels:

Link	From	To	Previous Circuits	Added Circuits	Resultant Circuits
9	HIN	DON	0	1	1
7	HIN	MTV	0	2	2
25	DON	HUM	0	3	3
20	MTV	HUM	0	5	5

Immediate and precedence level GOS are reduced to zero while routine remains at about 56 percent blockage.

The previous routing plan update did not attempt to remove all untenable paths to avoid useless occupation of common equipment and transmission facilities. Rather, it attempted to provide a quick restoration of priority service. A subsequent attempt was made to carefully redesign the routing table to remove all untenable paths and avoid futile occupation of facilities. It was conjectured that overall service would be improved by reduced waste. The resulting table required alteration of 62 node-to-node routing entries and, as verified by the interim routing plan verifier, removed all untenable paths. Overall improvement in comparison with the original routing plan modification was almost insignificant, with GOS reduced from 0.444 to 0.427. Immediate GOS rose, although the difference is the result of a single additional blocked call, while precedence GOS improved slightly with five fewer blocked calls. A recheck of common equipment utilization shows almost no saturation, which explains the lack of significant improvement. A check also showed that no calls were lost due to unavailability of an idle RSJ at the originating switch. Note that even a modest increase of offered traffic could send the common equipment into saturation, in which case the large scale rerouting alternative should provide significant improvement from the subscriber viewpoint.

1.3.5 Scenario SC1324A/C - Switch Failure at Feldberg

This scenario simulates loss of all switch functions at the Feldberg node, while multiplex capability remains intact. The regional or ACOC controller, being advised of the switch failure, must assess the situation and restore as much of the lost service as possible. Destination code cancellation is invoked due to isolation of Feldberg, and manual or automated channel reassignment is performed to maximize service through the remaining network facilities. The primary significance of this scenario is in the demonstration of the potential impact of a near real-time channel reassignment capability, and the need for computer aided assistance in the development of complex reassignment strategies.

The scenario perturbation occurs at time = 30 minutes with loss of switching capability at Feldberg. Following a report from ATEC of the switch failure, the ACOC or regional controller interrogates the physical

connectivity through the network diagram (Figure 1-35). All node pairs involving FEL are physically isolated due to the switch failure, so that destination code cancellation (DCC) from all nodes to FEL is called for. This directive is issued at time = 45 minutes. The primary purpose of the DCC is to prevent non-Feldberg calls from being blocked while calls to Feldberg tie up common equipment and transmission circuits in futile routing attempts. Figure 1-36 demonstrates the effect of the DCC on RSJ demand at several selected nodes. Note that LKF (4) and DON (8) demands increase most dramatically due to their frequent utilization as tandem switches to FEL. Note also that demand at LKF is reaching the critical level and could lead to dropped priority calls if DCC is not invoked.

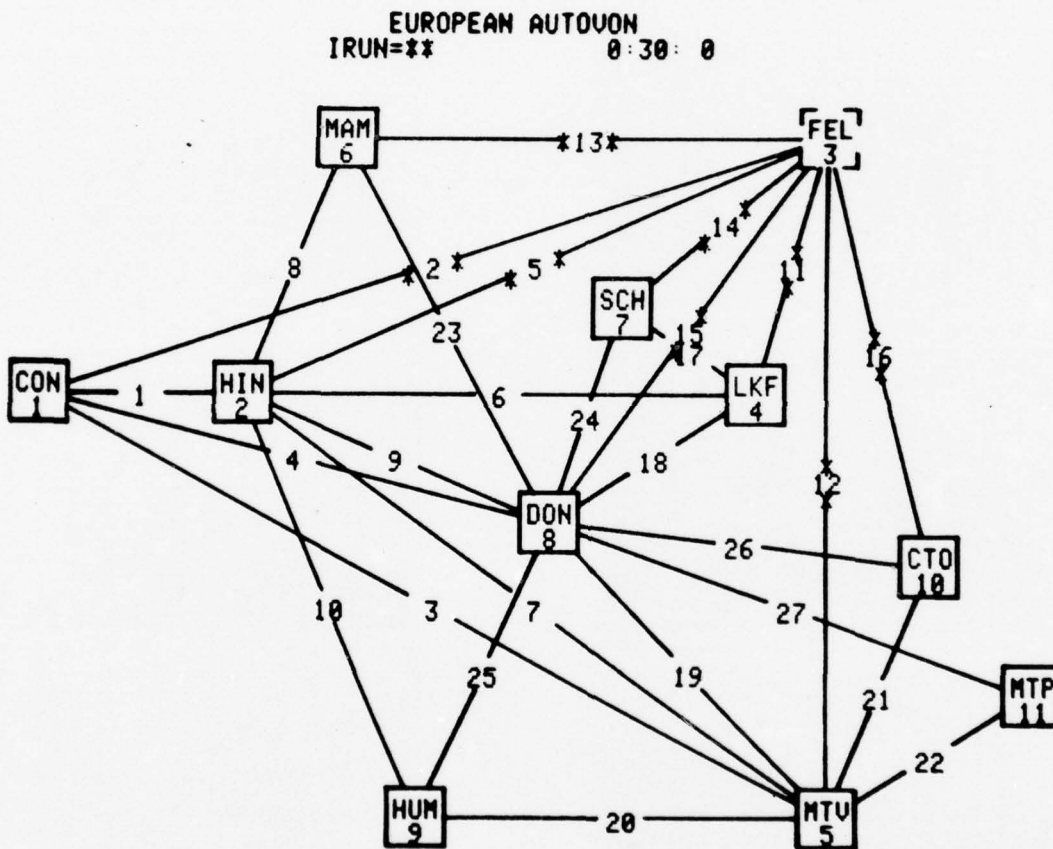

Figure 1-35. Connectivity Diagram Showing Switch Failure at Feldberg

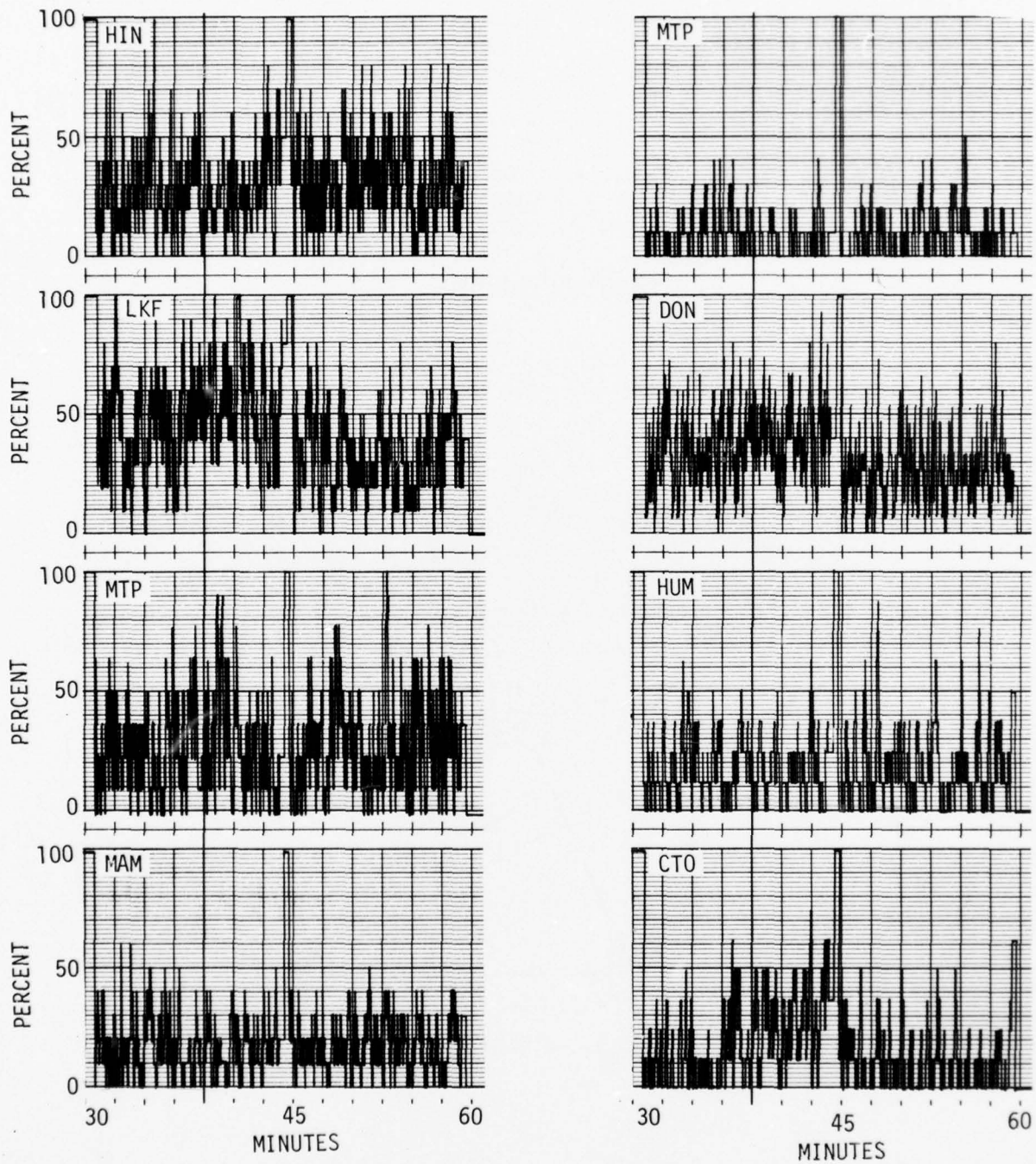

Figure 1-36. RSJ Percent Utilization Prior to and Following Implementation of DCC

The routing plan verifier is interrogated to determine if any logical isolation occurs for the indicated stress with the nominal routing plan. The resulting fault diagnostic only display (Figure 1-37) demonstrates that no additional isolation occurs, as Feldberg, node 3, is included in every isolated pair diagnostic. Also, no potential spill entrapment has been generated by the switch failure. The fault only diagnostic display requested did not display untenable paths, many of which exist due to the switch failure. These untenable paths are not of primary concern, but should be addressed secondarily if the stress persists for an extended time as they do generate useless seizure of common equipment and transmission circuits. Since no logical isolation occurs, routing plan revision is not suggested as an immediate action. Rather, it is important to reassign as much of the lost transmission resources as possible, as quickly as possible. This is most easily accomplished by manual or automatic crosspatching of circuits terminating at Feldberg to supplement logical links forming a triangle with Feldberg. Although this does not account for actual transmission paths and possible transmission loopback, it is the only practical approach for near real-time realization of channel reassignment without a complex dynamic channel reassignment function as an integral part of system control. Note also that in addition to crosspatching at the Feldberg multiplexers, it is necessary for switches adjacent to Feldberg to update routing functions to account for the modified capacities.

```

***** 0:30: 0*****
REMARKS          NS  ND RTE CKT NT1:S NT2:S NT3:S
***ISOL NODE PAIR***  1  3
***ISOL NODE PAIR***  2  3
***ISOL NODE PAIR***  3  1
***ISOL NODE PAIR***  3  2
***ISOL NODE PAIR***  3  4
***ISOL NODE PAIR***  3  5
***ISOL NODE PAIR***  3  6
***ISOL NODE PAIR***  3  7
***ISOL NODE PAIR***  3  8
***ISOL NODE PAIR***  3  9
***ISOL NODE PAIR***  3 10
***ISOL NODE PAIR***  3 11
***ISOL NODE PAIR***  4  3
***ISOL NODE PAIR***  5  3
***ISOL NODE PAIR***  6  3
***ISOL NODE PAIR***  7  3
***ISOL NODE PAIR***  8  3
***ISOL NODE PAIR***  9  3
***ISOL NODE PAIR*** 10  3
***ISOL NODE PAIR*** 11  3

```

Figure 1-37
Routing Plan Diagnostics

To explore channel reassignment for the specific stress indicated, it is first necessary to determine which trunk groups can be supplemented by reassignment of Feldberg links, and how many circuits can be and should be assigned to each. The first question is answered through examination of the Feldberg triangles, illustrated in Figure 1-38. This shows that the following links may be supplemented by crosspatch at Feldberg:

1	3	4	6	7	8	9
17	18	19	21	23	24	26

An examination of the link status display (Figure 1-39) indicates which of these circuits are heavily congested and therefore require additional capacity to handle the increased demand as traffic is routed around Feldberg. Of the above, links 1, 3, 5, and 9 are the most congested with about 50 percent blockage. Links 7 and 23 show about 20 percent blockage, and links 6, 18, 24, and 26 have a 2 to 6 percent blocking rate. Links 8, 17, 19, and 21 show no blockage over this reporting period from 30 to 45 minutes. If human assisted design of the reassignment strategy is to be feasible, a controller aid such as the channel reassignment diagram discussed in paragraph 1.1.4 is required. The manual procedure described here represents the basic operations of that controller aid.

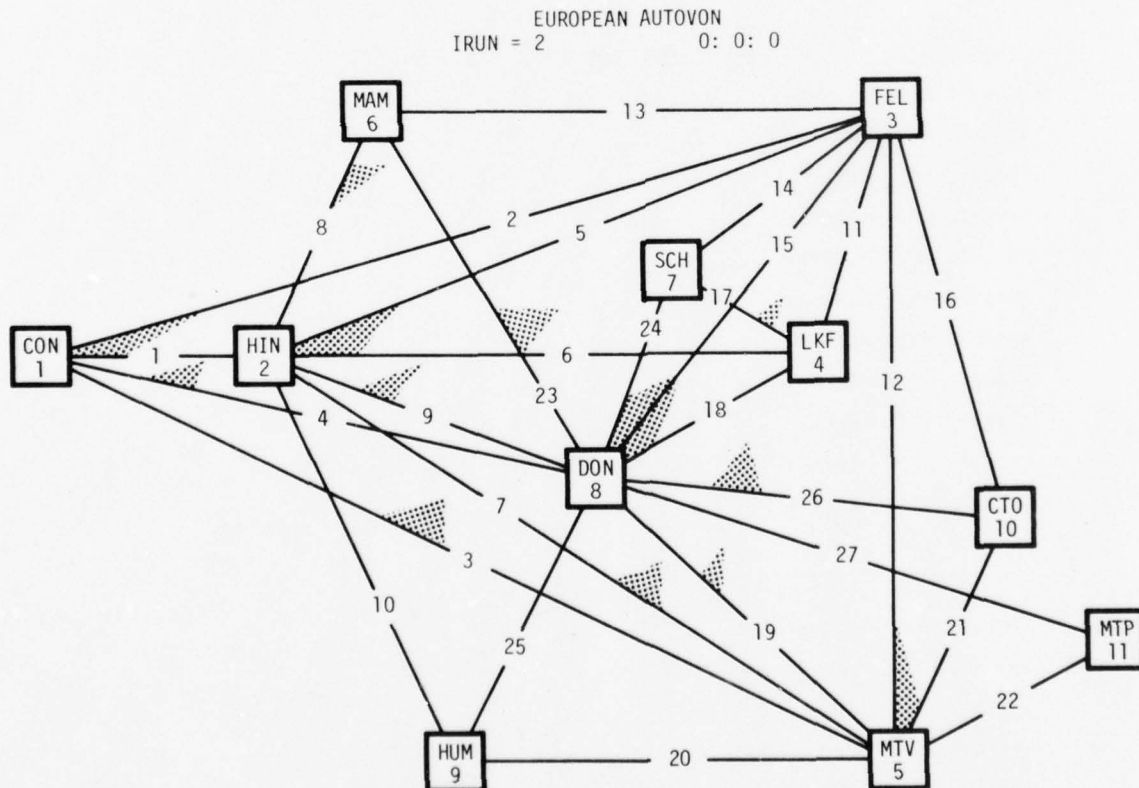

Figure 1-38. Feldberg Triangles

***** 0:45: 0*****

*ACCUMULATED LINK/PRIORITY GOS STATUS

LINK A	TOTAL		P0		P1		P2		P3		P4	
	BLCK/	ATTM=X,XX	BLCK/	ATTM	BLCK/	ATTM	BLCK/	ATTM	BLCK/	ATTM	BLCK/	ATTM
1 *	223/	456=0.49	0/	0	0/	0	115/	261	0/	0	108/	195
2***	173/	173=1.00	0/	0	0/	0	99/	99	0/	0	74/	74
3**	81/	142=0.57	0/	0	0/	1	49/	89	0/	0	32/	52
4 *	114/	242=0.47	0/	0	0/	0	55/	130	0/	0	59/	112
5***	107/	107=1.00	0/	0	0/	0	80/	80	0/	0	27/	27
6	2/	103=0.02	0/	0	0/	0	0/	51	0/	3	2/	49
7	15/	81=0.19	0/	0	0/	0	6/	44	0/	0	9/	37
8	0/	181=0.00	0/	0	0/	0	0/	98	0/	11	0/	72
9 *	23/	48=0.48	0/	0	0/	0	8/	20	1/	3	14/	25
10	0/	47=0.00	0/	0	0/	0	0/	18	0/	4	0/	25
11***	404/	404=1.00	0/	0	8/	8	93/	93	67/	67	236/	236
12***	152/	152=1.00	0/	0	0/	0	45/	45	20/	20	87/	87
13***	118/	118=1.00	0/	0	0/	0	84/	84	2/	2	32/	32
14***	29/	29=1.00	0/	0	0/	0	13/	13	1/	1	15/	15
15***	613/	613=1.00	0/	0	8/	8	105/	105	109/	109	391/	391
16***	82/	82=1.00	0/	0	0/	0	8/	8	11/	11	63/	63
17	0/	24=0.00	0/	0	0/	0	0/	3	0/	5	0/	16
18	16/	505=0.03	0/	0	0/	8	1/	78	4/	79	11/	340
19	0/	134=0.00	0/	0	0/	0	0/	17	0/	21	0/	96
20	0/	62=0.00	0/	0	0/	0	0/	11	0/	6	0/	45
21	0/	28=0.00	0/	0	0/	1	0/	5	0/	2	0/	20
22	0/	109=0.00	0/	0	0/	0	0/	33	0/	6	0/	70
23	24/	97=0.25	0/	0	0/	0	6/	27	3/	10	15/	60
24	4/	71=0.06	0/	0	0/	0	0/	14	0/	6	4/	51
25	0/	56=0.00	0/	0	0/	0	0/	5	0/	9	0/	42
26	5/	119=0.04	0/	0	0/	0	1/	11	0/	14	4/	94
27	1/	82=0.01	0/	0	0/	0	0/	9	0/	8	1/	65

Figure 1-39. Link Status Following Perturbation

Once it is determined which links can be supplemented and which of these require additional circuits, a matrix diagram such as that illustrated by Figure 1-40 is constructed. Across the top are the Feldberg links, which can donate capacity, and vertically are the triangle links requiring capacity. The Xs within the matrix designate the specific triangles and indicate which two Feldberg links must donate capacity to supplement the single triangle link. All triangle links have been included in spite of zero blockage, since initial reassessments may alter loading characteristics involving these links. As the controller decides to allocate circuits, the number of circuits allocated to each donee link is entered in the Xed boxes corresponding to that link. The total remaining circuit figures are entered to ensure that the donor links are not overallocated. This matrix diagram also demonstrates the dependence of the donee links in competing for limited donor resources. In the tradeoff decisions, trunk group size and blocking rates are significant factors. For two trunk groups with the same blocking rate and significantly different initial capacities, the larger trunk group requires a greater amount of supplemental capacity to make it nonblocking. Figure 1-41 presents the completed diagram for the reassignment strategy invoked in this scenario. The pivotal donor links proved to be 5 and 15, as they were each involved in several crucial triangles. All but one of the disrupted gateway circuits were reallocated to other gateway links, and

NOMINAL CIRCUITS		28	15	30	20	13	13	30	11	TOTAL CIRCUITS
LINK		2	5	11	12	13	14	15	16	
27	1	X	X							
9	3	X			X					
19	4	X						X		
14	6		X	X						
7	7		X		X					
34	8		X			X				
5	9		X					X		
8	17			X			X			
34	18			X				X		
15	19				X			X		
9	21				X				X	
12	23					X		X		
12	24						X	X		
12	26							X	X	
CIRCUITS REMAINING										

Figure 1-40. Reassignment Matrix for Feldberg

NOMINAL CIRCUITS		28	15	30	20	13	13	30	11	TOTAL CIRCUITS
LINK		2	5	11	12	13	14	15	16	
27	1	X 10	X 10							37
9	3	X 9			X 9					18
19	4	X 8						X 8		27
14	6		X 2	X 2						16
7	7		X 1		X 1					8
34	8		X			X				
5	9		X 2					X 2		7
8	17			X 7			X 7			15
34	18			X 2				X 2		36
15	19				X			X		
9	21				X 6				X 6	15
12	23					X 12		X 12		24
12	24						X 6	X 6		18
12	26							X	X	
CIRCUITS REMAINING		1	0	19	4	1	0	0	5	

Figure 1-41. Completed Reassignment Matrix for Feldberg

capacity available after other assignments was allocated to link 17. Figure 1-42 illustrates the effectiveness of the selected reassignment strategy by presenting network and precedence status prior to control (45 minutes), 15 minutes after DCC control only, and at 15 minutes after control with DCC and channel reassignment. This data includes calls destined to FEL, which enter the network and are then canceled, but not attempts originating at FEL that never enter the network. Removing all Feldberg attempts, since they cannot be serviced, results in overall GOS figures of 0.11, 0.25, and 0.04 for time = 45 minutes, time = 60 minutes with DCC only, and time = 60 minutes

PRIOR TO CONTROL

```

***** 0:45: 0*****
*ACCUMULATED TOTAL NETWORK STATISTICS*
ATTEMPTS BLOCKS COMPLETE PREEMPTED BL/ATT PR/COM
1298 575 723 83 0.4430 0.1148
***** 0:45: 0*****
*ACCUMULATED NETWORK PRECEDENCE STATISTICS*
PREC ATTEMPTS BLOCKS COMPLETE PREEMPTED BL/ATT PR/COM PREC
0 0 0 0 0 0.0000 0.0000 0
1 5 4 1 0 0.8000 0.0000 1
2 313 74 239 0 0.2364 0.0000 2
3 91 49 42 0 0.5385 0.0000 3
4 889 448 441 83 0.5039 0.1882 4

```

DCC CONTROL ONLY

```

***** 1: 0: 0*****
*ACCUMULATED TOTAL NETWORK STATISTICS*
ATTEMPTS BLOCKS COMPLETE PREEMPTED BL/ATT PR/COM
1312 502 810 126 0.3826 0.1556
***** 1: 0: 0*****
*ACCUMULATED NETWORK PRECEDENCE STATISTICS*
PREC ATTEMPTS BLOCKS COMPLETE PREEMPTED BL/ATT PR/COM PREC
0 0 0 0 0 0.0000 0.0000 0
1 0 0 0 0 0.0000 0.0000 1
2 293 35 258 0 0.1195 0.0000 2
3 75 24 51 0 0.3200 0.0000 3
4 944 443 501 126 0.4693 0.2515 4

```

DCC AND CHANNEL REASSIGNMENT

```

***** 1: 0: 0*****
*ACCUMULATED TOTAL NETWORK STATISTICS*
ATTEMPTS BLOCKS COMPLETE PREEMPTED BL/ATT PR/COM
1159 274 885 27 0.2364 0.0305
***** 1: 0: 0*****
*ACCUMULATED NETWORK PRECEDENCE STATISTICS*
PREC ATTEMPTS BLOCKS COMPLETE PREEMPTED BL/ATT PR/COM PREC
0 0 0 0 0 0.0000 0.0000 0
1 0 0 0 0 0.0000 0.0000 1
2 294 35 259 0 0.1190 0.0000 2
3 75 24 51 0 0.3200 0.0000 3
4 790 215 575 27 0.2722 0.0470 4

```

Figure 1-42. Network and Precedence Statistics Prior to and Following Control Actions

with DCC and reassignment, respectively. The resulting link status at 60 minutes with DCC and reassignment is presented in Figure 1-43. The strip-plot data for percent utilization of the triangle links is presented in Figure 1-44. Data of this latter type, if available to the network controller, can be especially valuable in evaluating the imposed reassignment strategy by illustrating where and how much excess capacity has been assigned. Here it is demonstrated that link 17 has considerable excess, and link 23 could be reduced by about 10 percent with no significant consequences. Since link 23 involves the pivotal link 15, a suggested iteration would reduce link 23 allotment by 1 circuit, adding that circuit to the gateway link 4. Further reallocation would probably be insignificant due to very low blockage on the rest of potentially affected links.

The potential effectiveness of near real-time channel reassignment has been demonstrated. However, the manual development of the reassignment required about 45 minutes. This is not adequate for near real-time realization. A computer-aided tool such as the interactive channel reassignment diagram (paragraph 1.1.5) should enable a strategy of this complexity to be designed in 10 to 15 minutes, which is suitable for near real-time realization.

```

***** 1: 0: 0*****
*ACCUMULATED LINK/PRIORITY GOS STATUS
LINK A      TOTAL          P0          P1          P2          P3          P4
            BLCK/ATTM=X.XX  BLCK/ATTM  BLCK/ATTM  BLCK/ATTM  BLCK/ATTM  BLCK/ATTM
1           92/ 309=0.30    0/ 0      0/ 0      41/ 162    0/ 0      51/ 147
2***       70/ 70=1.00     0/ 0      0/ 0      40/ 40     0/ 0      30/ 30
3 *        42/ 136=0.31    0/ 0      0/ 0      17/ 58     0/ 0      25/ 78
4           42/ 197=0.21    0/ 0      0/ 0      28/ 101    0/ 0      14/ 96
5***       20/ 20=1.00     0/ 0      0/ 0      13/ 13     0/ 0      7/ 7
6           16/ 116=0.14    0/ 0      0/ 0      4/ 60      1/ 2      11/ 54
7           12/ 57=0.21    0/ 0      0/ 0      4/ 26      0/ 1      8/ 30
8           0/ 88=0.00     0/ 0      0/ 0      0/ 22      0/ 8      0/ 58
9           13/ 45=0.29    0/ 0      0/ 0      7/ 18      2/ 6      4/ 21
10          17/ 68=0.25    0/ 0      0/ 0      6/ 26      0/ 4      11/ 38
11***      75/ 75=1.00     0/ 0      0/ 0      35/ 35     0/ 0      40/ 40
12***      31/ 31=1.00     0/ 0      0/ 0      10/ 10     1/ 1      20/ 20
13***      19/ 19=1.00     0/ 0      0/ 0      8/ 8       1/ 1      10/ 10
14***      11/ 11=1.00     0/ 0      0/ 0      9/ 9       0/ 0      2/ 2
15***      27/ 27=1.00     0/ 0      0/ 0      16/ 16     2/ 2      9/ 9
16***       2/ 2=1.00      0/ 0      0/ 0      1/ 1       1/ 1      0/ 0
17          0/ 19=0.00     0/ 0      0/ 0      0/ 1       0/ 4      0/ 14
18          9/ 175=0.05    0/ 0      0/ 0      2/ 27      2/ 18     5/ 130
19          0/ 45=0.00     0/ 0      0/ 0      0/ 1       0/ 5      0/ 39
20          0/ 42=0.00     0/ 0      0/ 0      0/ 5       0/ 1      0/ 36
21          0/ 33=0.00     0/ 0      0/ 0      0/ 5       0/ 2      0/ 26
22          0/ 70=0.00     0/ 0      0/ 0      0/ 16      0/ 3      0/ 51
23          0/ 95=0.00     0/ 0      0/ 0      0/ 11      0/ 9      0/ 75
24          0/ 60=0.00     0/ 0      0/ 0      0/ 16      0/ 3      0/ 41
25          5/ 47=0.11     0/ 0      0/ 0      2/ 8       0/ 4      3/ 35
26          2/ 37=0.05     0/ 0      0/ 0      1/ 3       0/ 4      1/ 30
27          2/ 26=0.08     0/ 0      0/ 0      0/ 3       0/ 3      2/ 20

```

Figure 1-43. Link Status Following Composite Control Action

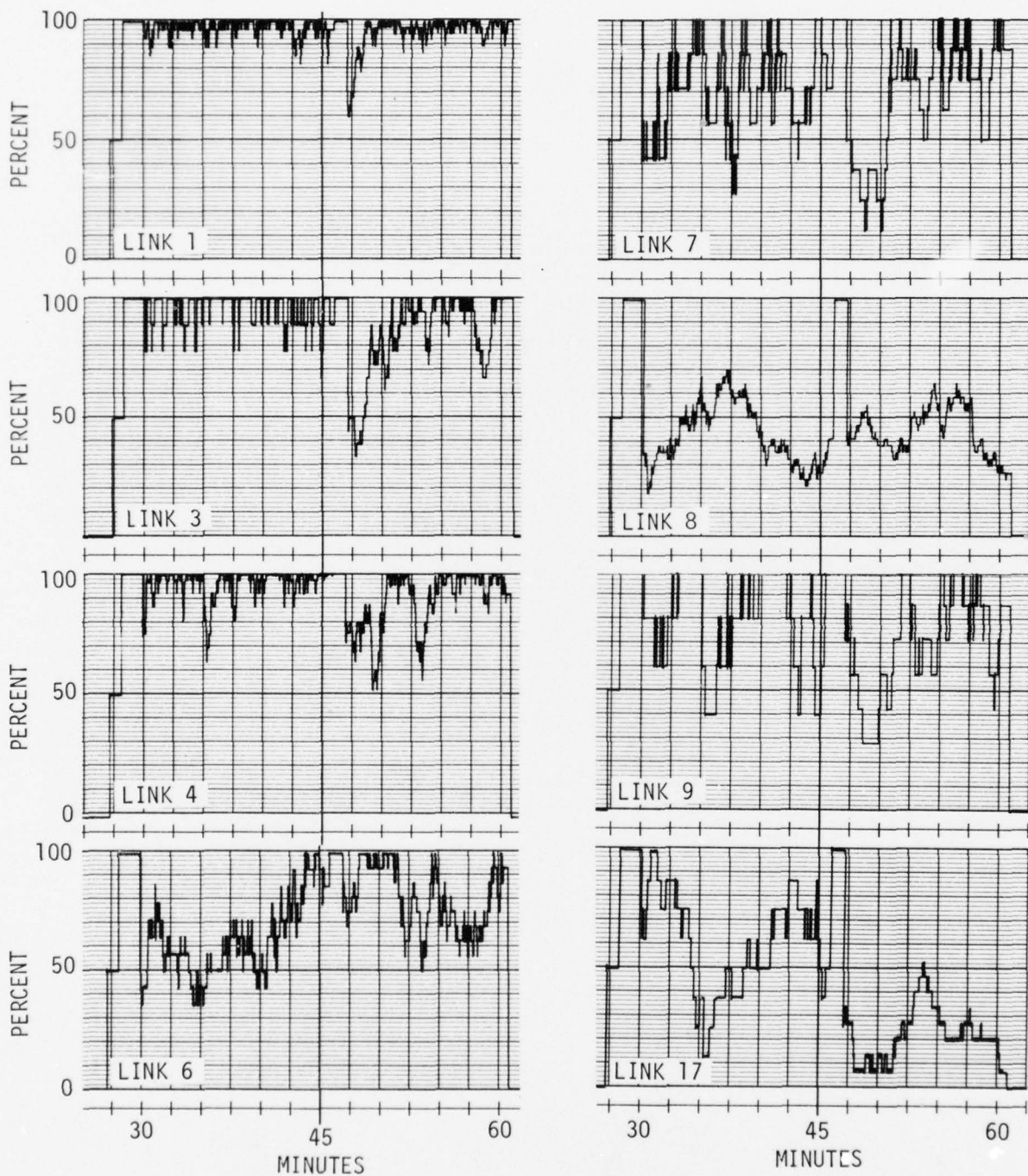

Figure 1-44. Percent Utilization of the Feldberg Triangle Links Prior to and Following Composite Control Implementation

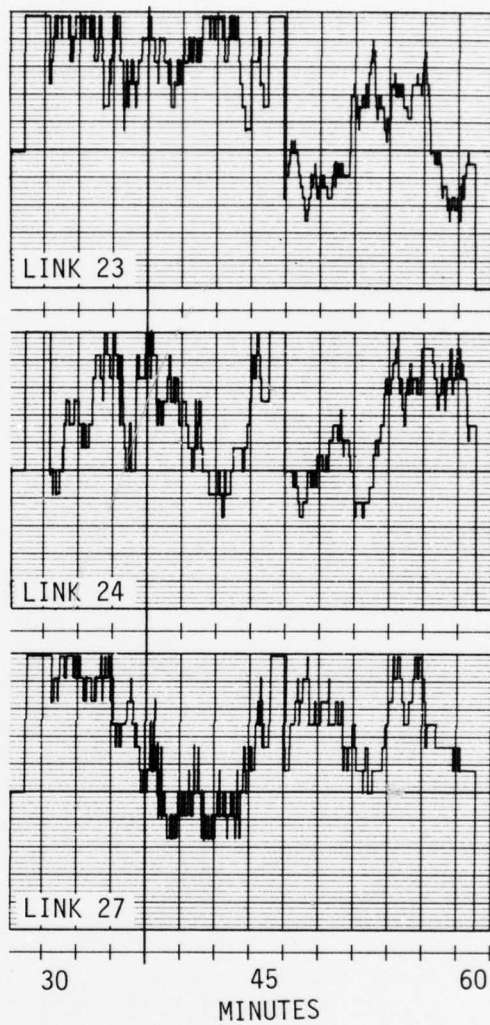
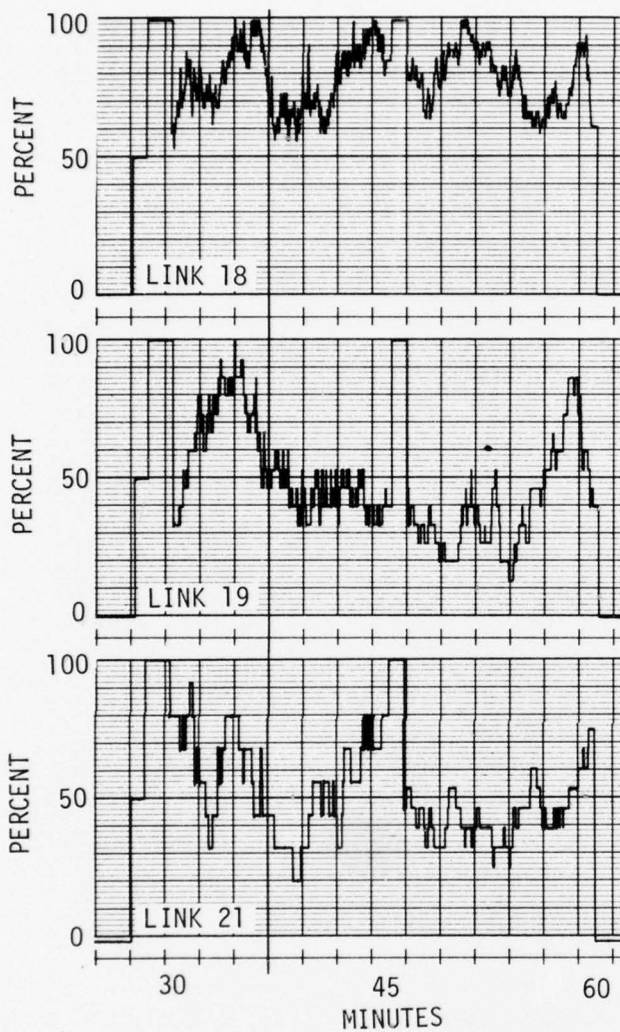

Figure 1-44. (Continued)

1.3.6 Scenario SC1127A/C - Partial Loss of Node Multiplex Capability

This scenario is designed to simulate the effect of partial loss of multiplex capability at the Feldberg node. The multiplexer circuits that do not access the circuit switch, i.e., they are patched through from input to output mux ports, are lost from service. Circuit switch operation is not affected by the failure, and it continues to process traffic normally until implementation of a control action. There is no isolation of node pairs as a result of this failure, although two links are completely interrupted, and trunk capacity on four others is reduced. Control actions implemented for this failure are channel reassignment and routing plan change. These controls were applied singly and as a combined action to demonstrate the need for multiple control actions for this failure.

The baseline scenario used for this study is SC1100 (No Call Reattempt traffic model). At 30 minutes into the run, partial loss of multiplex capability occurs, which results in a complete interruption in the transmission paths between Martlesham Heath and Donnersberg, and between Hillingdon and Donnersberg. Trunk group capacities between other nodes are also affected as indicated below.

Link	From	To	Original Trunks	Resultant Trunks
23	MAM	DON	12	0
9	HIN	DON	5	0
10	HIN	HUM	10	8
24	DON	SCH	12	2
19	DON	MTV	15	14
27	DON	MTP	7	6

The response of the link GOS and percent utilization data for links 6, 7, 9, 15, 17, 23, 24, 27 to the perturbation and control action is shown in Figure 1-45. The network status for the uncontrolled network over the 30 to 45 minute interval is illustrated in Figures 1-46 through 1-48. From the link GOS data it is seen that links 15, 17, 24, and 27 are experiencing excessive blocking. By reassignment of portions of the incapacitated link capacities via a programmable channel reassignment module (CRM) at the affected switches and updating the routing table to accommodate this reassignment, this stress condition can be alleviated. In reducing the link blockage probability, the RSJ and other common equipment demands will be reduced since blocked attempts tie up common equipment in futile efforts to route traffic over heavily loaded trunks.

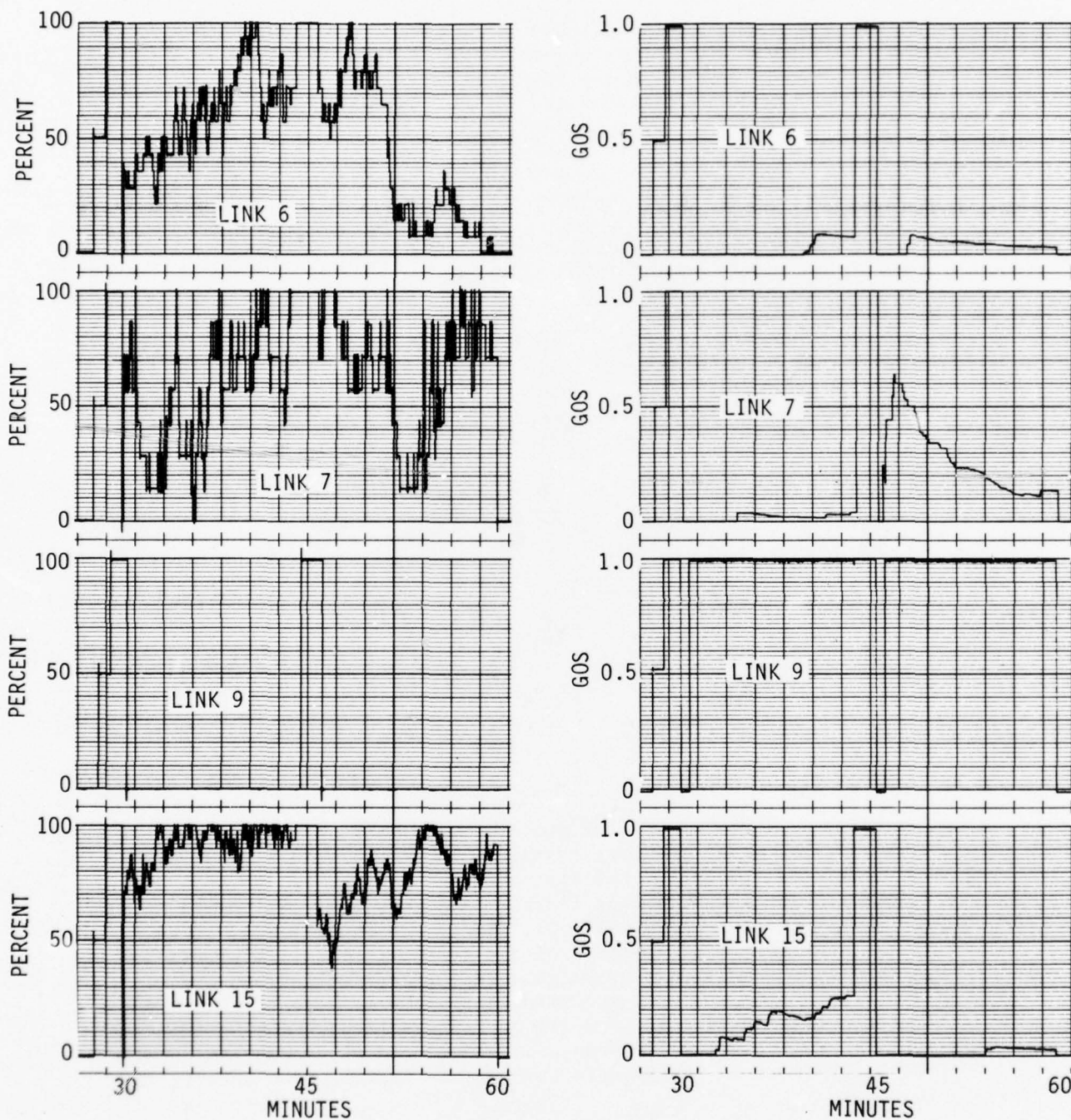

Figure 1-45. Percent Utilization and Link GOS for Selected European Links

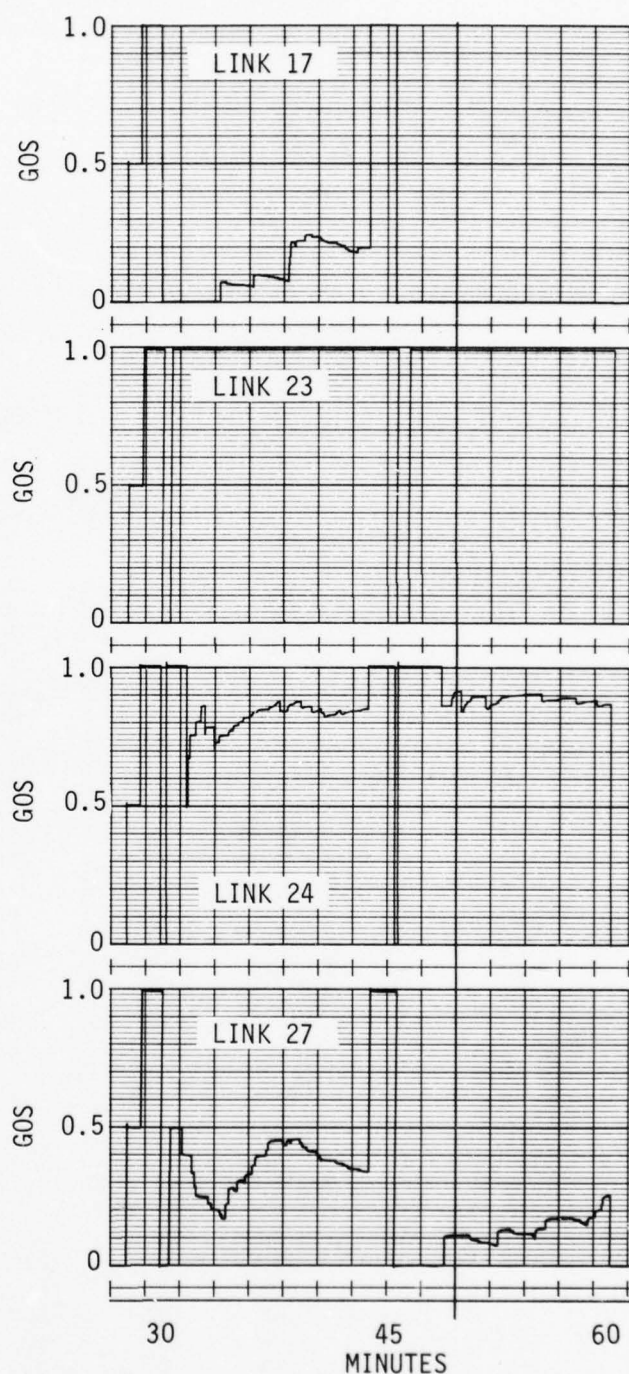
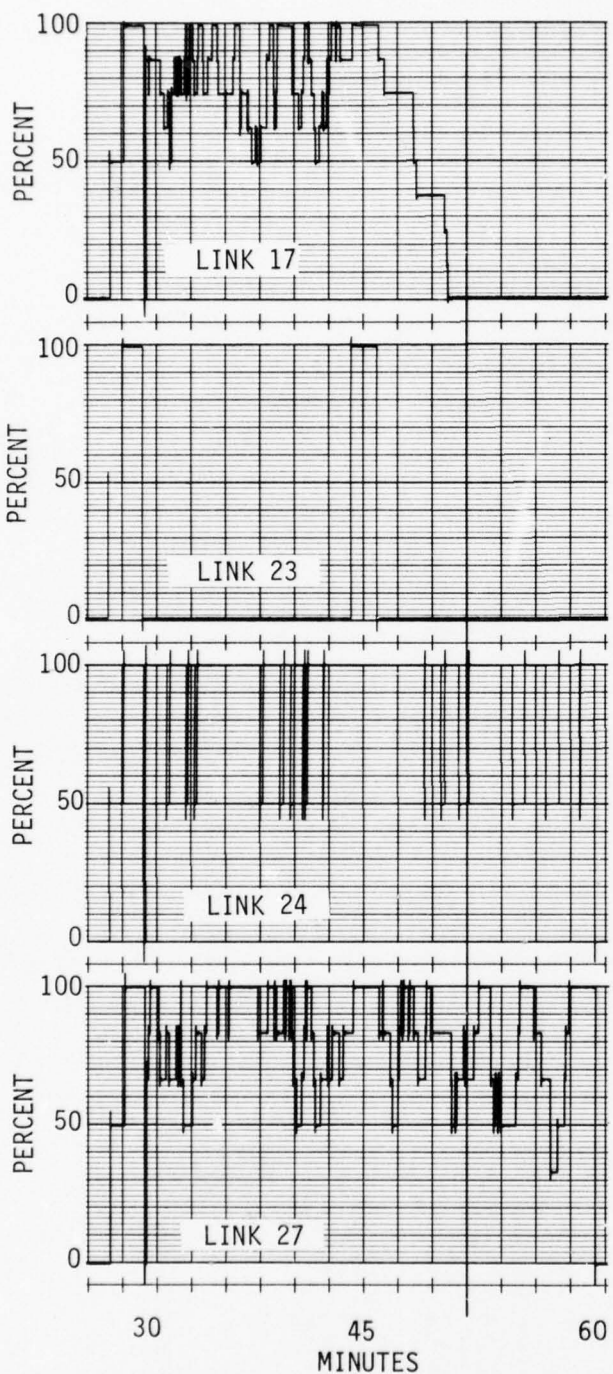

Figure 1-45. (Continued)

***** 0:45: 0*****
 ACCUMULATED TOTAL NETWORK STATISTICS
 ATTEMPTS BLOCKS COMPLETE PREEMPTED BL/ATT PR/COM
 1297 132 1165 90 0.1018 0.0773

***** 0:45: 0*****
 ACCUMULATED NETWORK PRECEDENCE STATISTICS
 PREC ATTEMPTS BLOCKS COMPLETE PREEMPTED BL/ATT PR/COM PREC
 0 0 0 0 0 0.0000 0.0000 0
 1 2 0 2 0 0.0000 0.0000 1
 2 373 0 373 0 0.0000 0.0000 2
 3 71 0 71 0 0.0000 0.0000 3
 4 851 132 719 90 0.1551 0.1252 4

Figure 1-46. Network Statistics for Loss of Partial Multiplex Capability

***** 0:45: 0*****
 *ACCUMULATED LINK/PRIORITY GOS STATUS

LINK A	TOTAL	P0	P1	P2	P3	P4
	BLCK/ATTM=X,XX	BLCK/ATTM	BLCK/ATTM	BLCK/ATTM	BLCK/ATTM	BLCK/ATTM
1**	227/ 406=0.56	0/ 0	0/ 1	127/ 233	0/ 0	100/ 172
2**	307/ 471=0.65	0/ 0	1/ 2	165/ 271	0/ 0	141/ 198
3**	113/ 175=0.65	0/ 0	0/ 0	59/ 100	0/ 0	54/ 75
4**	137/ 253=0.54	0/ 0	0/ 0	62/ 138	0/ 0	75/ 115
5	8/ 119=0.07	0/ 0	0/ 1	5/ 62	0/ 0	3/ 56
6	8/ 102=0.08	0/ 0	0/ 0	6/ 45	0/ 1	2/ 56
7	3/ 73=0.04	0/ 0	0/ 0	3/ 40	0/ 0	0/ 33
8	0/ 113=0.00	0/ 0	0/ 0	0/ 42	0/ 2	0/ 69
9***	70/ 70=1.00	0/ 0	0/ 0	18/ 18	0/ 0	52/ 52
10	2/ 48=0.04	0/ 0	0/ 0	0/ 18	0/ 2	2/ 28
11	8/ 207=0.04	0/ 0	0/ 0	2/ 84	0/ 12	6/ 111
12	0/ 97=0.00	0/ 0	0/ 0	0/ 40	0/ 3	0/ 54
13	0/ 58=0.00	0/ 0	0/ 0	0/ 10	0/ 1	0/ 47
14	4/ 59=0.07	0/ 0	0/ 0	0/ 9	0/ 6	4/ 44
15	69/ 262=0.26	0/ 0	0/ 0	14/ 48	2/ 14	53/ 200
16	0/ 36=0.00	0/ 0	0/ 0	0/ 3	0/ 5	0/ 28
17	10/ 51=0.20	0/ 0	0/ 0	0/ 3	1/ 6	9/ 42
18	6/ 212=0.03	0/ 0	0/ 0	0/ 44	1/ 19	5/ 149
19	0/ 44=0.00	0/ 0	0/ 0	0/ 1	0/ 4	0/ 39
20	0/ 59=0.00	0/ 0	0/ 0	0/ 12	0/ 4	0/ 43
21	0/ 29=0.00	0/ 0	0/ 0	0/ 5	0/ 6	0/ 18
22	4/ 90=0.04	0/ 0	0/ 0	1/ 29	0/ 7	3/ 54
23***	91/ 91=1.00	0/ 0	0/ 0	15/ 15	1/ 1	75/ 75
24***	49/ 58=0.84	0/ 0	0/ 0	2/ 3	6/ 9	41/ 46
25	7/ 62=0.11	0/ 0	0/ 0	0/ 9	0/ 3	7/ 50
26	0/ 38=0.00	0/ 0	0/ 0	0/ 1	0/ 5	0/ 32
27 *	13/ 38=0.34	0/ 0	0/ 0	0/ 0	2/ 4	11/ 34

Figure 1-47. Link/Priority GOS for Loss of Partial Multiplex Capability

***** 0:45: 0*****
 ACCUMULATED SOURCE NODE NETWORK STATISTICS

NODE	ATTEMPTS	BLOCKS	COMPLETE	PREEMPTED	BL/ATT	PR/COM	NODE
1	189	22	167	35	0.1164	0.2096	1
2	96	12	84	7	0.1250	0.0833	2
3	202	16	186	11	0.0792	0.0591	3
4	181	13	168	7	0.0718	0.0417	4
5	65	9	56	5	0.1385	0.0893	5
6	81	13	68	3	0.1605	0.0441	6
7	55	5	50	0	0.0909	0.0000	7
8	188	34	154	10	0.1809	0.0649	8
9	89	1	88	5	0.0112	0.0568	9
10	62	2	60	1	0.0323	0.0167	10
11	89	5	84	6	0.0562	0.0714	11

Figure 1-48. Source Node Network Statistics for Loss of Partial Multiplex Capability

The channel reassignment was implemented, as indicated in Table 1-10, using portions of the incapacitated links. In updating the routing plan, additional traffic was avoided from being routed over the heavier loaded links (6, 7, 17, 24) in favor of the lighter loaded links (11, 13, 14, 15, 18). Also a portion of the traffic between Langerkopf (4) and Schoenfeld (7) on link 17 was rerouted over links 11 (Langerkopf-Feldberg) and 14 (Feldberg-Schoenfeld) to relieve some of the stress on link 17. The update to the routing table is shown in Table 1-11.

TABLE 1-10. CHANNEL REASSIGNMENT DATA FOR LOSS OF PARTIAL MULTIPLEX CAPABILITY

From Link \ To Link	HIN-DON (9)	HIN-HUM (10)	DON-MTV (19)	DON-MAM (23)	DON-SCH (24)	DON-MTP (27)	Original Circuits	New Total
HIN-FEL (5)	5						15	20
FEL-LKF (11)		2		12			30	44
MAM-FEL (13)				12			13	25
FEL-SCH (14)		2			10		13	25
DON-FEL (15)	5		1		10	1	30	47
FEL-CTO (16)			1			1	11	13
LKF-DON (18)				12			34	46
CTO-MTV (21)			1			1	9	11
MTV-MTP (22)						1	18	19
Original Circuits	5	10	15	12	12	7		
Circuits Remaining	0	8	14	0	2	5		

TABLE 1-11. ROUTING TABLE UPDATE FOR LOSS OF PARTIAL MULTIPLEX CAPABILITY

*ROUTING TABLE FOR NODES *NS* TO *ND* WITH TANDEM PATH NODES *NTI** AND SPILL INDICATORS *SI* FOR PATHS *I**

NS	ND	NT1:S	NT2:S	NT3:S	NT4:S
2	4	3:1	6:1	4:1	0:0
2	7	3:1	6:1	4:1	0:0
2	8	6:1	3:1	8:1	0:0
3	6	6:1	2:1	0:0	0:0
4	2	3:1	2:1	0:0	0:0
4	6	3:1	2:1	8:1	0:0
4	7	3:1	7:1	8:1	0:0
4	8	8:1	3:1	7:1	0:0
6	4	3:1	8:1	2:1	0:0
6	7	3:1	8:1	0:0	0:0
6	8	3:1	8:1	0:0	0:0
7	2	3:1	4:1	0:0	0:0
7	4	3:1	8:0	0:0	0:0
7	6	3:1	8:0	0:0	0:0
7	8	8:1	3:1	4:1	0:0
8	2	3:1	2:1	6:1	0:0
8	6	3:1	6:1	2:1	0:0
8	7	7:1	3:1	4:1	0:0

The control action was initiated 45 minutes into the run. For the channel reassignment control action applied by itself, the total network GOS 15 minutes after control initiation was 0.1061. With the routing plan change control action initiated by itself, the total networks GOS was 0.1422. For the combined control action, the total network GOS was 0.0996. These values compare to a total network GOS for the uncontrolled baseline scenario SC1100 of 0.1339. The resulting network, and originating node and link statistics 15 minutes after application of the combined control action are presented in Figures 1-49, 1-50, and 1-51. Blockage on links 15, 25, and 27 has been reduced, however, link 24 blockage remained approximately the same. Blockage on links 7, 10, and 13 increased due to traffic being rerouted through them. Traffic on link 17 was reduced to zero although it remained as a first alternate from Langerkopf (4) to Schoenfeld (7). This indicates that the primary route was carrying all of the traffic.

1.4 Simulator Enhancements

Several significant enhancements have been implemented in the interactive network simulator since the interim report. Foremost of these is the modeling of common equipment in the call routing process. Side effects of the common equipment update included the conversion to trunk-by-trunk routing storage and the employment of dynamic allocation of certain program arrays. A second major enhancement is the revised network diagram, which has resulted in a more versatile and informative controller tool. A preliminary version of the routing plan verifier has been implemented and the simulator command options have been extended. Both immediate action and batch mode command menus have been extended. These extensions have been primarily directed at improving multiple scenario and on-line control sequence operations. The fourth area of update has been AUTOVON network model, which has been modified in accordance with the 4 November 1978 CONUS gateway upgrade. A recall version of the European traffic model has also been developed. These regions of enhancement are discussed in more detail in the following paragraphs.

1.4.1 Common Equipment Update

The implementation of common equipment processing in the interactive network simulator represents the capability for significant improvement in simulation realism. Basically, this update has divided the routing process into timed intervals to simulate the delays associated with subscriber dialing and interswitch signaling delays. The principle item of common equipment is the receiver sender junctor (RSJ). In the current model, each switch is allocated a specific number of RSJ units, and each unit is allocated a memory space for status and connectivity information. The ground-work has been implemented for including transceiver availability (DTMF receivers and MF transceivers), although this is considered secondary in importance to RSJ availability and has not yet been fully realized. The common equipment version of the interactive network simulator uses a trunk-by-trunk status storage in addition to the RSJ-by-RSJ status and chronological event queuing to facilitate route sequencing and retracing. Status information includes cross pointer information among the three types of

```

***** 1: 0: 0*****
*ACCUMULATED TOTAL NETWORK STATISTICS*
ATTEMPTS BLOCKS COMPLETE PREEMPTED BL/ATT PR/COM
1301    185    1116    133 0.1422 0.1192

```

```

***** 1: 0: 0*****
*ACCUMULATED NETWORK PRECEDENCE STATISTICS*
PREC ATTEMPTS BLOCKS COMPLETE PREEMPTED BL/ATT PR/COM PREC
0      0      0      0      0 0.0000 0.0000 0
1      3      0      3      0 0.0000 0.0000 1
2     380     1    379     0 0.0026 0.0000 2
3      80     0     80     0 0.0000 0.0000 3
4     838    184    654    133 0.2196 0.2034 4

```

Figure 1-49. Network Statistics for Combined Control Action

```

***** 1: 0: 0*****
*ACCUMULATED LINK/PRIORITY GOS STATUS
LINK A      TOTAL          P0          P1          P2          P3          P4
BLCK/ATTM=X.XX BLCK/ATTM BLCK/ATTM BLCK/ATTM BLCK/ATTM BLCK/ATTM
1** 271/ 444=0.61 0/ 0 1/ 2 134/ 239 0/ 0 136/ 203
2** 341/ 521=0.65 0/ 0 1/ 3 175/ 295 0/ 0 165/ 223
3** 147/ 212=0.69 0/ 0 1/ 1 81/ 117 0/ 0 65/ 94
4** 171/ 288=0.59 0/ 0 0/ 0 88/ 167 0/ 0 83/ 121
5   24/ 160=0.15 0/ 0 0/ 1 7/ 62 2/ 4 15/ 93
6   1/ 78=0.01 0/ 0 0/ 0 1/ 37 0/ 0 0/ 41
7 * 48/ 105=0.46 0/ 0 0/ 0 29/ 51 0/ 1 19/ 53
8   0/ 139=0.00 0/ 0 0/ 0 0/ 46 0/ 7 0/ 86
9*** 71/ 71=1.00 0/ 0 0/ 0 32/ 32 3/ 3 36/ 36
10 * 22/ 67=0.33 0/ 0 1/ 1 5/ 30 1/ 1 15/ 35
11  50/ 259=0.19 0/ 0 0/ 0 13/ 80 5/ 21 32/ 158
12  0/ 123=0.00 0/ 0 0/ 1 0/ 55 0/ 1 0/ 66
13 * 60/ 143=0.42 0/ 0 0/ 1 11/ 26 5/ 18 44/ 98
14 * 31/ 101=0.31 0/ 0 0/ 0 6/ 18 3/ 11 22/ 72
15  47/ 301=0.16 0/ 0 0/ 0 12/ 77 2/ 27 33/ 197
16  2/ 43=0.05 0/ 0 0/ 0 0/ 7 0/ 6 2/ 30
17  0/ 17=0.00 0/ 0 0/ 0 0/ 2 0/ 3 0/ 12
18  13/ 190=0.07 0/ 0 0/ 0 4/ 40 2/ 18 7/ 132
19  0/ 49=0.00 0/ 0 0/ 0 0/ 5 0/ 6 0/ 38
20  0/ 70=0.00 0/ 0 0/ 1 0/ 16 0/ 7 0/ 46
21  0/ 33=0.00 0/ 0 0/ 0 0/ 3 0/ 5 0/ 25
22  2/ 60=0.03 0/ 0 0/ 0 0/ 25 0/ 1 2/ 34
23*** 53/ 53=1.00 0/ 0 0/ 0 12/ 12 4/ 4 37/ 37
24*** 50/ 59=0.85 0/ 0 0/ 0 8/ 10 5/ 5 37/ 44
25  10/ 57=0.18 0/ 0 0/ 0 2/ 9 2/ 10 6/ 38
26  2/ 35=0.06 0/ 0 0/ 0 0/ 6 0/ 3 2/ 26
27  1/ 31=0.03 0/ 0 0/ 0 0/ 1 0/ 3 1/ 27

```

Figure 1-50. Link/Priority GOS for Combined Control Action

```

***** 1: 0: 0*****
*ACCUMULATED SOURCE NODE NETWORK STATISTICS*
NODE      ATTEMPTS BLOCKS COMPLETE PREEMPTED BL/ATT PR/COM      NODE
1         191    38    153    31 0.1990 0.2026    1
2         112    16    96    14 0.1429 0.1458    2
3         190    27    163    22 0.1421 0.1350    3
4         199    18    181    13 0.0905 0.0718    4
5          70     5    65    10 0.0714 0.1538    5
6          83    22    61     5 0.2651 0.0820    6
7          55     9    46     2 0.1636 0.0435    7
8         193    33    160    17 0.1710 0.1062    8
9          84     6    78     9 0.0714 0.1154    9
10        58     2    56     4 0.0345 0.0714   10
11        66     9    57     6 0.1364 0.1053   11

```

Figure 1-51. Source Node Network Statistics for Combined Control Action

route storage elements. Dynamic allocation of these and other storage arrays is used to reduce the memory requirement for small networks and to increase flexibility in large network dimensioning without the necessity of recompiling program elements. The node pair by precedence traffic statistics were reprogrammed as node pair statistics in conjunction with one of several precedence distribution functions. This conserves program memory, improves program computational efficiency, and significantly reduces the burden of defining new networks by reducing the number of required data cards. Other network definition entries were also reprogrammed to account for common equipment, to facilitate allocation of dynamic arrays, and to further reduce the number of data cards necessary for network definition.

Description of Incremental Routing Process

Figures 1-52 through 1-54 functionally illustrate the incremental routing process associated with the common equipment model. The chronological queue contains four types of events. These are pending calls, calls destined for termination, calls awaiting completion of dialing or signaling, and calls awaiting an idle RSJ. As in the precommon equipment model, events are synchronized within a frame interval (nominally one second). Stripplotting and controller requests are processed between successive frames. Except for the trunk-by-trunk route storage, call termination processing is essentially unchanged from the precommon equipment model.

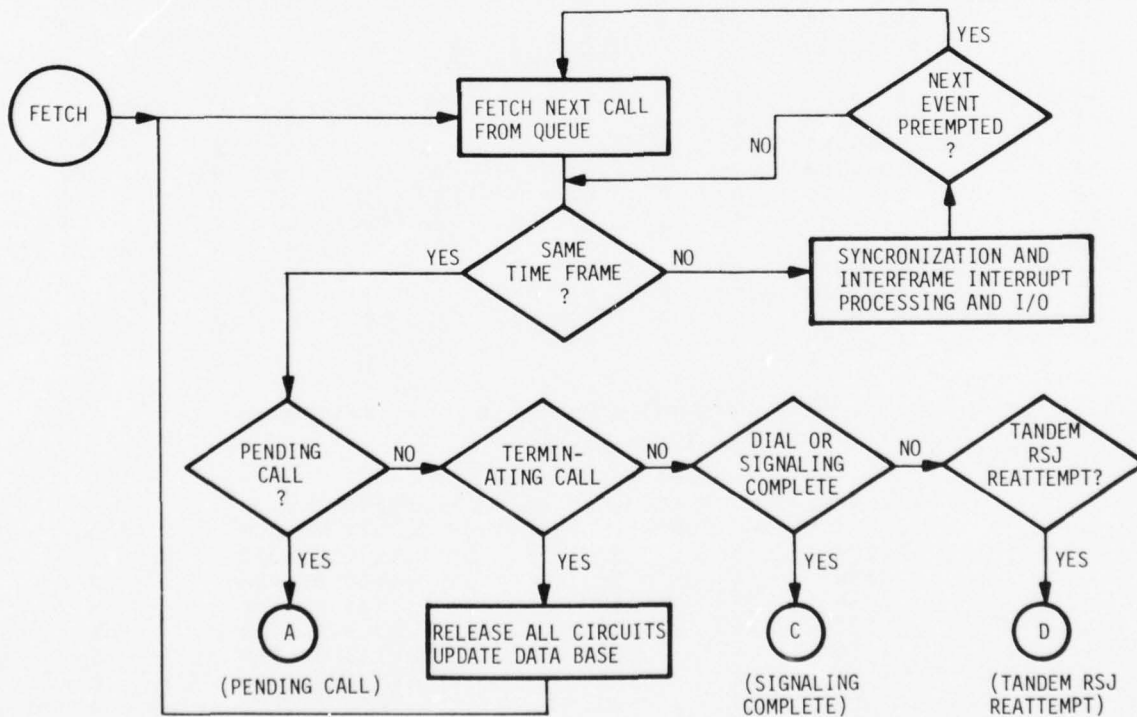

Figure 1-52. Common Equipment Queue Processing - Queue Entry Interpretation

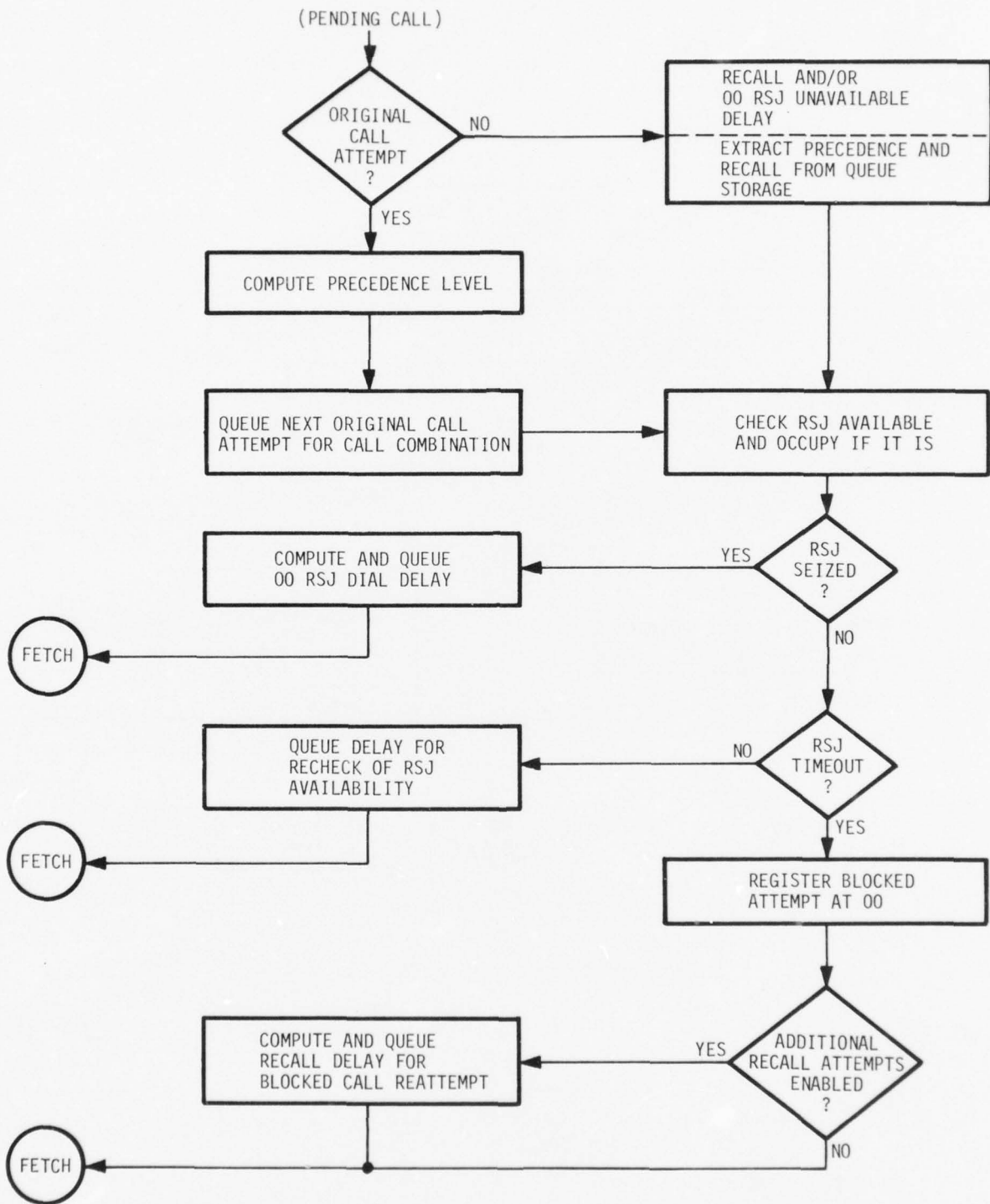

Figure 1-53. Functional Flow Diagram for Pending Call Processing

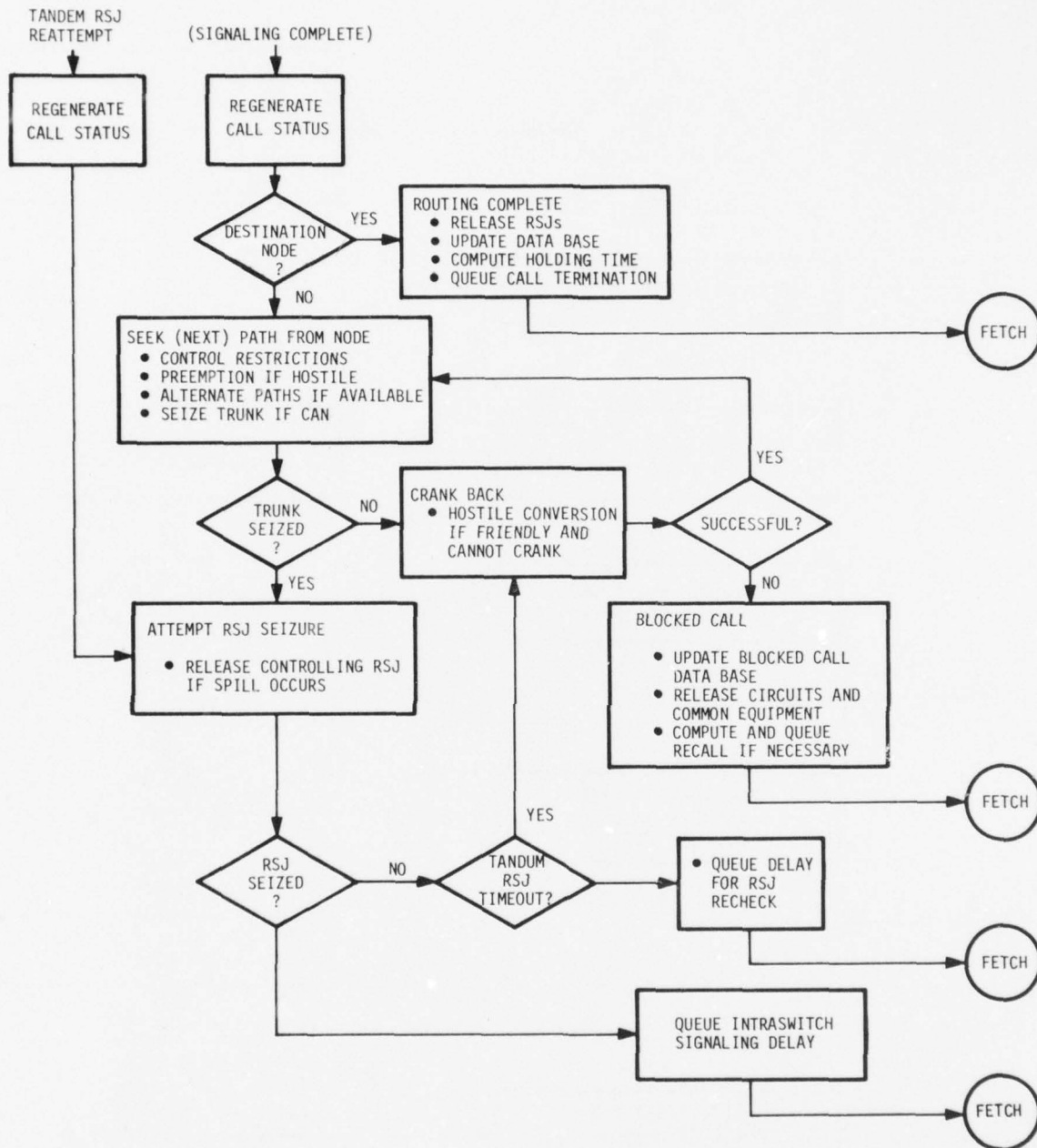

Figure 1-54. Functional Flow Diagram for Processing Signaling Complete and Random RSJ Reattempt Events

The call pending process, illustrated in Figure 1-53, has changed considerably. First, the event status is interrogated to differentiate between original calls and blocked calls or unavailable originating office RSJ attempts. The former requires precedence computation. This is accomplished through random selection from a prestored precedence distribution associated with the node pair of the pending call. The original call is regenerated for the next call from that particular node pair. Reattempts carry precedence and recall information with them. Once precedence is determined, an attempt is made to seize an RSJ at the originating switch. If successful seizure is accomplished, the subscriber dialing delay is queued and the next event is fetched from the chronological queue. If an idle RJS cannot be seized, timeout is checked. Timeout simulates the subscriber hangup in response to lack of dial tone. If timeout occurs within the current frame, a blocked subscriber attempt is registered. If block call reattempts are to be generated, a new call time is randomly generated and queued. The next event is then fetched from the chronological queue.

The signaling complete and tandem RSJ reattempt events (Figure 1-54) are unique to the common equipment version of the simulator. Once the signaling delay is complete, the receiving RSJ interprets the call code to determine if the destination node is reached. If this is the destination, the RSJs are released, a holding time is computed, and call termination is queued. If this is a tandem node, a path is sought. In attempting a trunk seizure, allowable alternate paths and preemption (if the search is hostile) are invoked as necessary. If no path can be seized, crankback is attempted, and a friendly search is converted to hostile if required. If crankback is to no avail, a blocked call is registered and occupied common equipment and transmission circuits are released. If enabled, a blocked call reattempt is queued. If a trunk seizure is realized, an idle RSJ is sought at the adjacent node. If found, the interswitch signaling delay is queued. If not found, the RSJ is checked for timeout. If timeout occurs, crankback is attempted as for trunk seizure failure. Otherwise, an RSJ recheck delay is queued. When the queued tandem RSJ reattempt is made, the RSJ signal is reattempted as above.

The fulcrum of the incremental routing process is the status and cross link information contained in the trunk, RSJ, and chronological queue memory cells. Trunk storage consists of 64 bits per trunk. Twelve bits are reserved for self-trunk group number and remain unaltered; 1 bit denotes direction of current occupation, 4 bits are reserved for call precedence, 16 bits are set aside for a forward pointer (zero if unoccupied), 2 bits contain 01 to denote trunk, 5 bits are reserved for control information, and 24 bits are used to store time and trunk seizure. RSJ storage occupies 96 bits. Eight bits denote self-trunk group and remain unaltered; 2 bits contain 00 to denote RSJ; 10 bits are reserved for control information; 8 bits denote destination node; 4 bits each are reserved for precedence, number of paths allowed, current path seized, transceiver information, and current use (originating office, spill forward, potential spill forward, tandem); 16 bits each are reserved for forward reference (zero if idle), reverse RSJ reference (if tandem switch), and reverse trunk reference (if not originating office). Chronological queue store requires 128 bits. Three 16-bit

pointers are reserved for the triple link list of the chronological table and one 16-bit pointer references trunk or RSJ storage. Two bits are 10 to denote queue storage. Sixteen bits are set aside for call combination, 32 bits for event time, 4 bits denote event type, and the remaining bits are event oriented. Through the interconnection of these three storage types, calls are routed, terminated, and preempted.

Dynamic Array Storage

To meet the increased demands on memory of the common equipment data base, new arrays and many old arrays were implemented in dynamic memory. Dynamic memory is allocated at the time of network definition, and allocation for specific data base arrays is restricted to current dimensional requirements rather than to maximized programmed dimensions. Thus, smaller networks require less program memory, and larger network models are more flexibly tailored to available memory. This does require some a priori knowledge of memory requirements of specific models if efficient use is to be made of computational resources, but this information is readily available when model data is first loaded. Certain reallocation options are also available after network model definition is entered. This includes reallocation of trunk, RSJ, and chronological queue store tables to facilitate changes in maximum allowable trunks per trunk group, RSJs per node, and/or queue events pending.

New Network Definition Format and Data Conversion

This section describes the standard sequence for definition of a network model. First, maximum network dimensions are read. These include maximum number of trunk groups, switches, call combinations, precedence levels, paths per node, distinct traffic distributions, and transceiver types, and determine much of the dynamic storage allocation. Second, bias levels are read for trunk, switch, and call combination numbering. This allows numbering to start at other than unity without wasting storage space. Individual trunk group data are then read as trunk group number, source node, destination node, maximum allotted capacity, and nominal capacity. Switch information is then read as node number, X and Y coordinate positions for plotting, switch capacity, maximum and nominal numbers of RSJ units, and numbers of each transceiver types. Call combination information follows, with call combination number, source, and destination nodes, distribution numbers, and traffic level. Next, the nominal routing table is defined as source node, destination node, and primary path node and spill or alternate tandem specification followed by alternate path nodes with spill or alternate tandem specifications. Finally, specific precedence distribution functions are defined as distribution number followed by percent of calls occurring at each precedence level from highest to lowest precedence. The use of precedence distribution tables and node pair traffic level has significantly decreased the bulk of network definition data and has permitted more efficient use of computational and storage resources.

A model translation program was written and used to convert network models programmed for precommon equipment versions of the interactive network simulator to common equipment versions. With this routine, dimensional and common equipment information is input from a unit separate from the old data file. The distinct precedence distributions associated with the network traffic model are derived from the old data, and network coordinate information is reformatted. A new data file is generated in the standard common equipment network definition format. Note that new data files for the two major subnetworks of the Overseas AUTOVON (Europe and Pacific) were created from the single old Overseas file. Each theater model retains its respective numbering, and through bias setting, each maintains maximum data base storage efficiency in the network simulator.

1.4.2 Network Diagram Update

The network diagram subprogram has been updated to meet certain simulation requirements and to reflect changes suggested in the interim report. The network diagram now operates as part of the controller task, so interactive network diagramming can be realized. The plotting routines have been reprogrammed for computational and program storage efficiency. The diagram itself now contains more information, including node mnemonic and trunk number, as depicted in the European diagram of Figure 1-55. Alarm status is currently displayed as shown in Figure 1-56 for node failure (node 6) and for trunk failure (trunk group 13). The program model has been made flexible so the controller may request a regional blowup, as is also demonstrated in Figure 1-56 with automatic rescaling of coordinates. The program module is also easily reprogrammed to allow alternate status or alarm information to be displayed, although this currently requires subprogram recompilation.

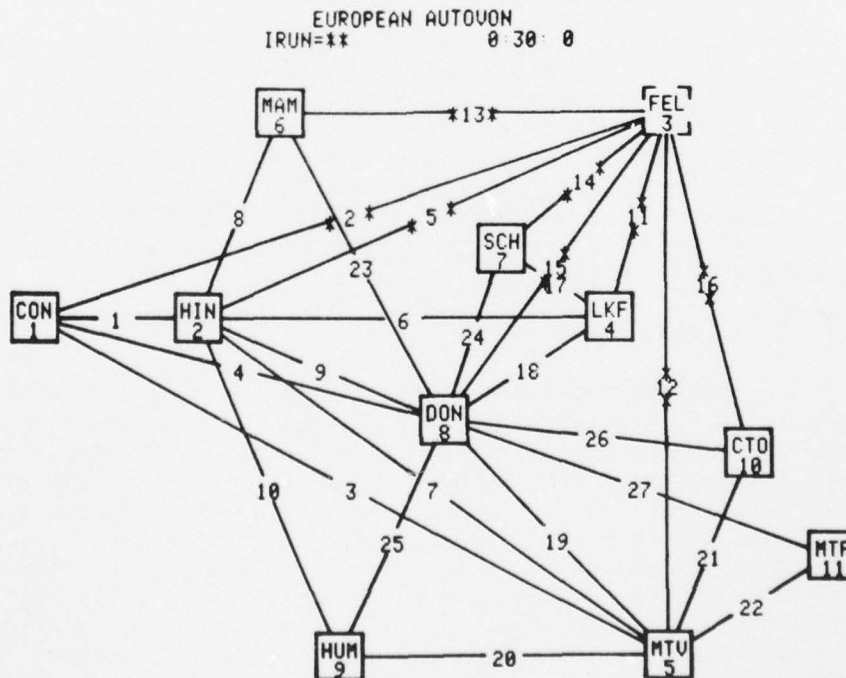

Figure 1-55. European AUTOVON Network Diagram

EUROPEAN AUTOVON
IRUN=** 1: 0: 0

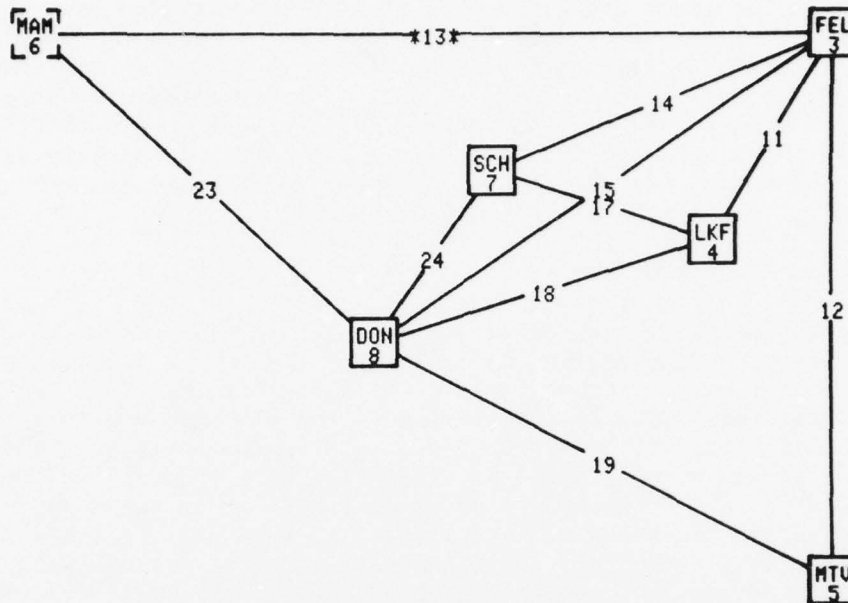

Figure 1-56. Regional Closeup with Alarm Indication

1.4.3 Preliminary Routing Plan Verifier

A preliminary version of the routing plan verifier (RPV) discussed in paragraph 1.1.4 has been implemented in the network simulator. The current RPV has the capability of testing node-by-node routing sequences, as illustrated in Figure 1-57. Either general or regional node-by-node displays can be requested. Potential loopback situations and node pair isolation are flagged, and paths blocked due to trunk group or switch failure can be tested, as portrayed in the diagnostic only listing of Figure 1-58. This routing plan verifier was prompted by and was used extensively in the scenario analysis of paragraph 1.3.

1.4.4 Simulation Command Options

Many batch mode and immediate action command options have been added to increase simulator flexibility. Several of these options are file oriented, allowing the operator to freely assign and rewind logical units under program control rather than under system console control. This has proven particularly beneficial for multiple scenario generation, where different prestored command sequence and scenario definition files may be alternately assigned to generate complex scenarios. One frequent use has been a prestored command to rewind and transfer to that file, thus replacing up to 15 lines of periodic controller request input. Several command options have also been implemented to accommodate the common equipment update. The current batch mode and immediate action command options are summarized in Appendix B.

```

***** 0:30: 0*****
REMARKS      NS  ND RTE  CKT  NT1:S  NT2:S  NT3:S
3           4   1   30   4:1
              2   30   8:1   4:1
3           5   1   20   5:1
              2   15   8:1   5:1
4           3   1   30   3:1
              2   30   8:1   3:1
4           5   1   15   8:1   5:1
              2   20   3:1   5:1
5           3   1   20   3:1
              2   15   8:1   3:1
5           4   1   15   8:1   4:1
              2   20   3:1   4:1

```

Figure 1-57. Node-by-Node Routing Plan Display

```

***** 0:30: 0*****
REMARKS      NS  ND RTE  CKT  NT1:S  NT2:S  NT3:S  NT4:S
**LOOPBACK/ROR**  1  3  **   0   8:0   4:1   8:0
***ISOL NODE PAIR***  1  3
***ISOL NODE PAIR***  2  3
**LOOPBACK/ROR**  4  3  **   0   8:0   4:1   8:0
***ISOL NODE PAIR***  4  3
***ISOL NODE PAIR***  5  3
***ISOL NODE PAIR***  6  3
**LOOPBACK/ROR**  7  3  **   0   8:0   4:1   8:0
***ISOL NODE PAIR***  7  3
**LOOPBACK/ROR**  8  3  **   0   4:1   8:0   4:1
***ISOL NODE PAIR***  8  3
***ISOL NODE PAIR***  9  3
***ISOL NODE PAIR*** 10  3
***ISOL NODE PAIR*** 11  3

```

Figure 1-58. Diagnostic Only Routing Plan Display

1.4.5 AUTOVON Model Update

The European AUTOVON 4 November 1978 CONUS gateway upgrade necessitated a corresponding revision of the AUTOVON network model. Because of the addition of the European gateway from CONUS to Donnersberg, a new link was added to the European model. To maintain the contiguous numbering of the gateway links, the new gateway was designated link four and other European and Pacific links were renumbered upward as necessary. Since prior removal of Taipei had vacated three link numbers (36, 39, and 40) and node 15 in the Pacific, the AUTOVON renumbering also served to eliminate these vacancies. The nominal routing plan has also been updated in the network simulation model in accordance with DCS documentation of the 4 November 1978 CONUS gateway upgrade. Appendix A provides a listing of the updated connectivity and routing tables associated with the 4 November 1978 upgrade. All scenarios presented in this report use the 4 November 1978 data.

An alternate traffic model has been established for the European theater of operation. Nominal traffic levels provided by DCS documentation have included normal blocked call reattempts. Individual blocked call reattempts were disabled with this data base, so as not to generate abnormally high busy hour traffic levels. However, certain scenarios involve stress environments which significantly increase call blockage and, hence, call reattempts. Therefore a new traffic model was generated. Some CONUS traffic is normally blocked at about 15 percent in comparison with about 1 percent for the non-CONUS traffic; only traffic levels to and from CONUS were altered. A CONUS traffic level reduction to 75 percent normal with the addition of a five reattempt maximum recall function provided very similar long term network, node, link, and call combination statistics for the nominal and recall traffic models. The five reattempt times are exponentially distributed with means of 0.25, 2.0, 6.75, 16.0, 31.25, and 54.0 minutes from first to fifth, respectively. Several of the scenarios of paragraph 1.3 use this alternate traffic model to simulate congestion resulting from blocked call reattempts. Appendix C provides baseline scenario runs for both the nominal and alternate European traffic models using the 4 November 1978 data.

2.0 TRANSMISSION SYSTEM SIMULATION

This section documents the results and progress of the transmission system simulations and software support. Hybrid computer models for digital line-of-sight modems have been designed, and remote user interactive configuration change, data reduction, and graphic display program software have been designed and verified.

The quadrature partial response (QPR) and quadrature phase shift keyed (QPSK) modulation techniques have been modeled for the Digital Radio and Multiplexer Application (DRAMA) line-of-sight modem. Checkout and verification tests of the DRAMA simulation have been conducted for noise, Rayleigh, fading, and line-of-sight channels.

The Computational Sciences Laboratory (CSL) has developed a line-of-sight fading channel model using the experience acquired from previous simulations for Rayleigh fading and troposcatter. The line-of-sight channel model has been developed to allow the remote user to arbitrarily alter the channel characteristics. Software has been developed that allows the user to load in a desired channel profile characteristic and tap delay spacing. The line-of-sight fading channel model makes use of the special analog delay simulation developed for the troposcatter channel model. The delay simulator uses state-of-the art charge coupled devices (CCDs) as delay elements to provide for the desired analog tapped delays. This method provides the higher bandwidth than other methods, allowing simulation frequencies of 20 kHz to be processed on the hybrid computing system. The channel model has been verified for each tap, and the results of the verification process appear in a later section.

The Martin Marietta Computational Sciences Laboratory (CSL) has developed electromagnetic vulnerability simulations that may be used as interferers with and without the line-of-sight and troposcatter. These interference types include tone interference, noise block interference, and delayed replica interference. Digital support software has been developed that allows the describing parameters for each of these interference types to be specified by the user through the hybrid remote terminal.

Other LOS transmission system simulations that have been designed are the eight-phase shift keyed (8 PSK), three-level partial response (3 LPR), and four-level frequency modulation (4 LFM). The 8-PSK transmission system is an extension of the QPSK technique. The 8-PSK modulation/demodulation was achieved through the modeling of two QPSK modulator/demodulators in parallel and a $\pi/4$ phase shifter.

The 3-LPR and 4-LFM are FM modulation techniques used for line-of sight applications. The 4-LFM simulation was developed under a previous DCA contract, DCA100-75-C-0058. The 3-LPR modulation technique is similar to the 4-LFM system, except the bit stream is not converted to two symbol streams in quadrature, and the baseband filters are partial response filters.

Development of the simulation methodology for the Adaptive Decision Feedback Equalizer (ADFE) digital transmission technique for troposcatter applications has been done by the CSL. The modulation technique, data decoders, demultiplexers, and other elements of the ADFE use modeling techniques previously developed for the Distortion Adaptive Receiver (DAR). Techniques that are peculiar to ADFE are discussed in paragraph 2.4.

2.1 Digital Line-of-Sight Modem Simulation

The quadrature partial response (QPR) and quadrature phase shift keyed (QPSK) line-of-sight (LOS) digital transmission techniques have been modeled and programmed on the hybrid computer. Figure 2-1 is the implemented model functional flow diagram.

The QPR dual diversity technique uses a partial response filter in each of the symbol data streams that drive the in-phase and quadrature balanced mixers. These mixers are summed to generate a QPR modulated signal that has eight predominant states. On the received side of the modem the demodulator uses a complementing partial response filter in the I and Q baseband signal paths to recover in-phase and quadrature-transmitted baseband signals. The demodulation technique is a modified Costas loop that can be used for either QPR or QPSK transmission with minor variations. It includes a data estimation technique to phase-lock a reference carrier to the received signal for coherent detection. Flexibility is provided in the simulation design to allow for configuration change, parameter change, and immediate changeover between QPR and QPSK modulation and demodulation.

2.1.1 Simulation Time Scale

To simulate the functions of an actual microwave transmission and receiving system on a hybrid computer requires a time and frequency scaling of each element in the system, which is a function of time. For the DRAMA system, a convenient scale factor of 26.112K was selected. Both baseband and IF elements in the model are scaled by this factor; for example, the DRAMA bit rate is 26.112 Mb/s and is simulated at a scaled frequency of 1 Kb/s. The scaled transmitter oscillator is 2681 Hz, which corresponds to the 70 MHz actual frequency of the system.

2.1.2 DRAMA Data Input and Transmitter Simulator

The simulated data input and transmitter sections of the Digital Radio and Multiplexer Application (DRAMA) include a data generator, serial-to-parallel converter, differential encoder, baseband I and Q filters and a modulator, either QPR or QPSK. Optional modules include two bandpass filters for limiting the transmitted spectrum, a nonlinear amplifier (AM/AM and AM/PM) conversion, and a data scrambler.

QPR OR QPSK TRANSMITTER

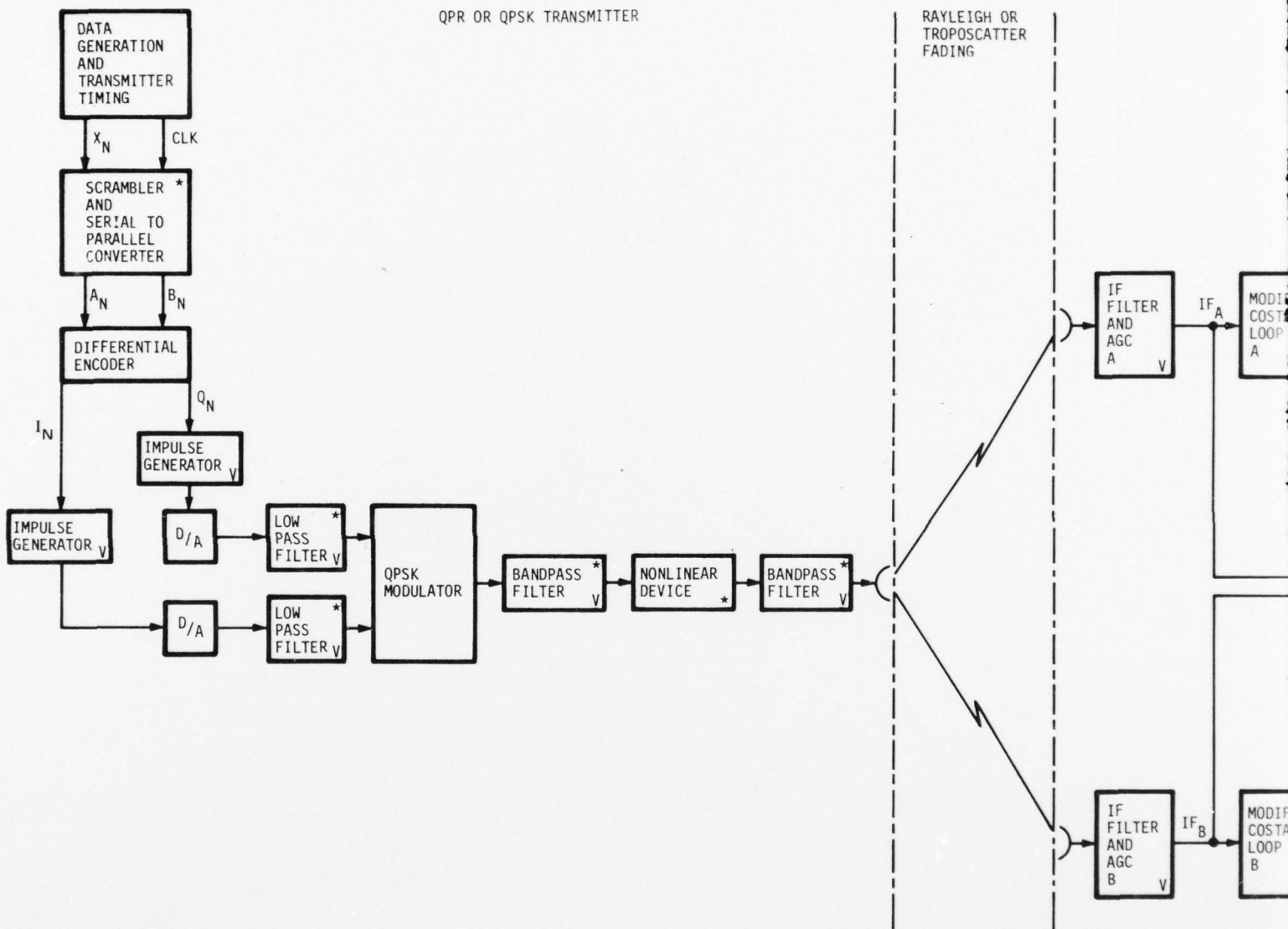

QPR OR QPSK RECEIVERS

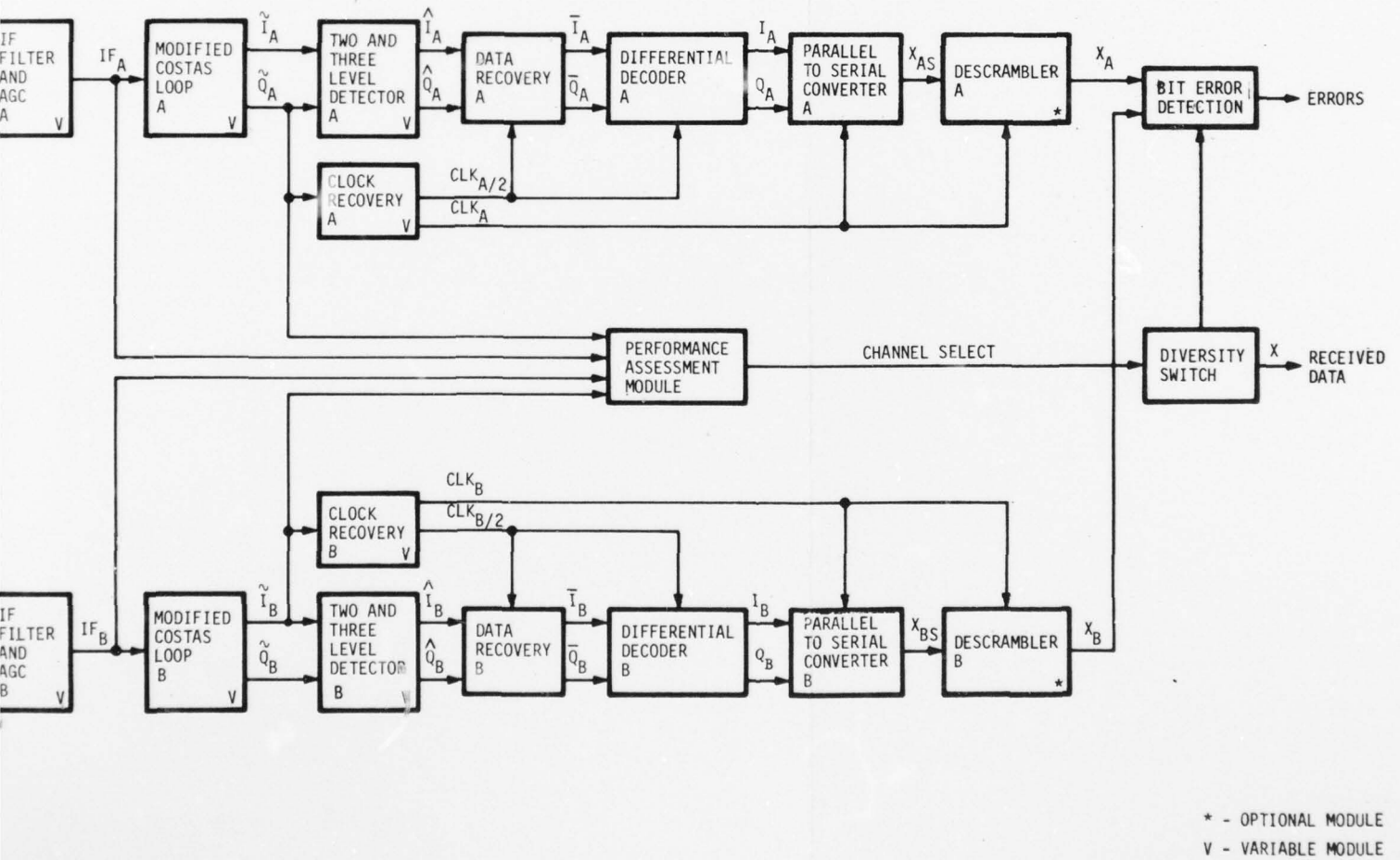

Figure 2-1. QPR and QPSK Dual Diversity Simulation

To generate a digital serial multiplexed bit stream, a Gaussian noise source is sampled using a simulated transmitter clock and analog track and store amplifier. The transmitter bit-rate clock is derived from the 100 kHz computer clock and down-counted to provide a 1 kHz clock for bit timing. The resulting serial bit stream may be input to an optional 20-bit scrambler.

A model of the scrambler is shown in Figure 2-2. Scrambling is obtained by modulo 2 summing the serial data stream with the modulo 2 sum of bits 17 and 20 of the 20-stage shift register. The scrambled or unscrambled data is input to the serial-to-parallel converter that drives the differential encoder. All these data input circuits are programmed using the parallel logic capability of the analog computer.

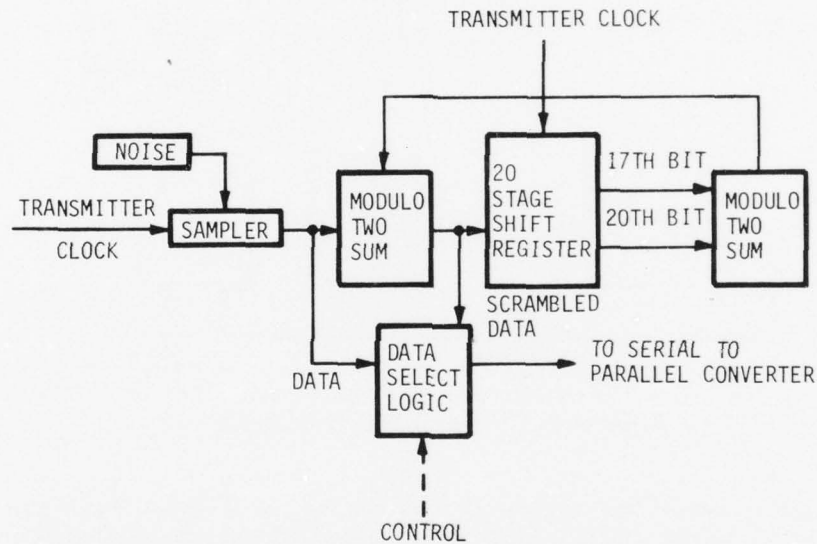

Figure 2-2. QPR/QPSK Data Input Model

2.1.3 QPR/QPSK Modulator Simulation

At the modulator two paths are simulated for the encoded digital baseband data as shown in Figure 2-3. These two paths permit the simulation user to select the proper baseband signal at the balanced mixers either QPR or QPSK transmission. The balanced mixers have as one input the in-phase and quadrature baseband signals, and the other input is the in-phase and quadrature signals, output by an amplitude and frequency stabilized oscillation programmed on the analog computer. The balanced mixers are programmed using analog computer multipliers.

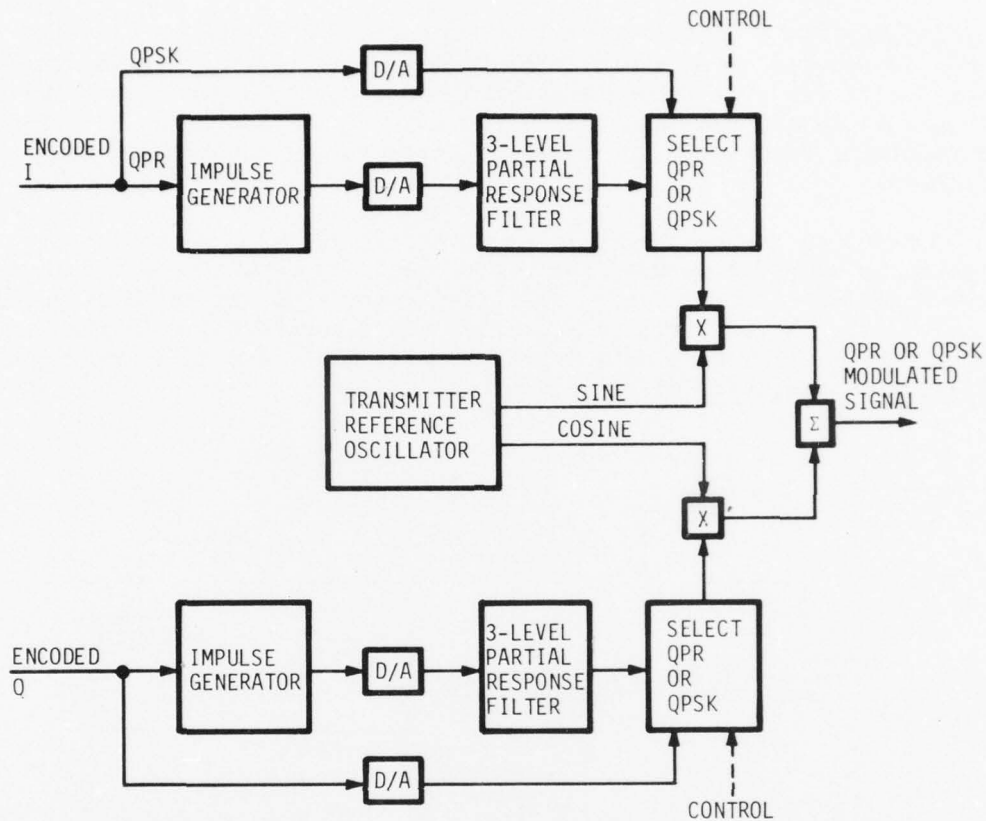

Figure 2-3. QPR/QPSK Modulator

If the QPR modulation option is selected, the I and Q baseband signals are generated by using the encoded I and Q nonreturn to zero (NRZ) logic to drive impulse generators. This impulse stream is the driving function for the Class I partial response filters. Responses of these filters coupled with identical filters in the receiver produce a three-level baseband signal. The output of the transmitter partial response filter produces the analog baseband signal, which is input to the balanced mixers. The transmit partial response filters are programmed from the transfer function:

$$H(s) = \frac{3.25104}{s^4 + 4.3966s^2 + 9.28835s^2 + 8.105s + 3.25104}$$

Analog computer techniques for transfer function simulation were used to model these filters.

The partial response filter was designed to fit the frequency and the impulse response of a Class I, partial response filter. This approach ensures the desired intersymbol interference with adjacent pulses and prevents undesired intersymbol interference with other pulses.

The impulse response for the partial response filter is shown in Figure 2-4. It is desired to mechanize this filter as two identical fourth order stages as shown in Figure 2-6. The first half is in the transmitter and the other in the receiver.

The filter design was derived from a method based on the piecewise linear approximation to the impulse response curve shown in Figure 2-4. $Y(1)$, $Y(2)$, and $Y(3)$ are the ordinates of the curve for the equally spaced sample points. The system block diagram resulting from this approach is shown in Figure 2-5. This system was mechanized, allotting fourth order transfer functions to the triangular pulse generator and the delay chain, each formed as the square of a second order transfer function. Thus the identical transmitters and receiver filters are formed from second order parts of the triangular pulse generator and delay chain.

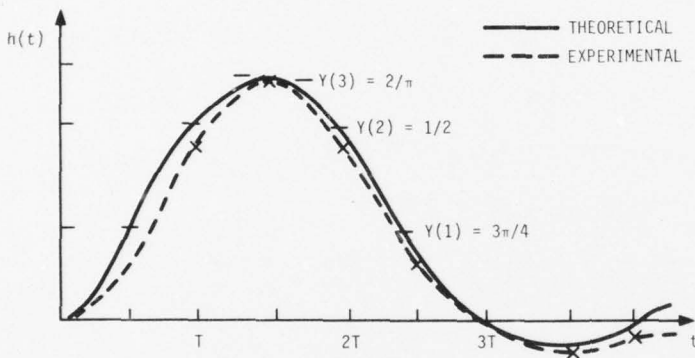
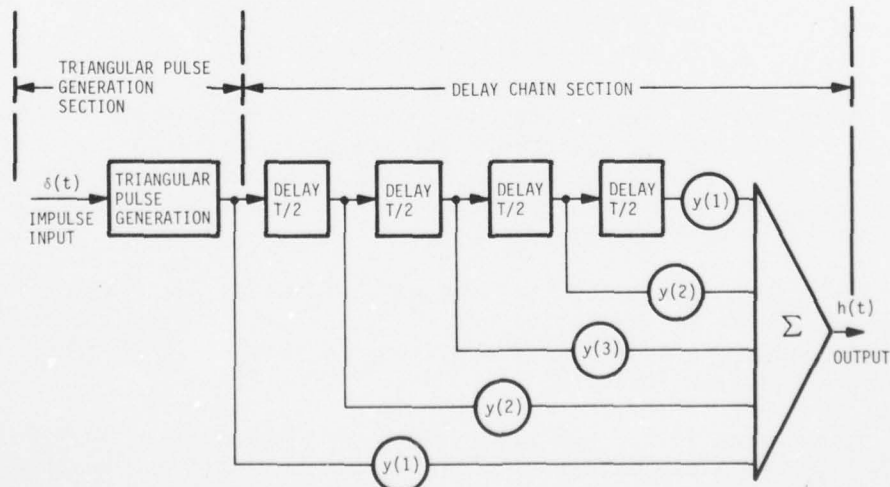

Figure 2-4. Partial Response Filter Impulse Response, $h(t)$

$$h(t) = \frac{2}{\pi} \left\{ \frac{\sin \omega_c (t-T)}{(t-T)} u(t-T) + \frac{\sin \omega_c (t-2T)}{(t-2T)} u(t-2T) \right\}$$

WHERE ω_c IS THE FILTER CUTOFF FREQUENCY



$$H(s) = T(s) \left\{ y(1) + y(2)e^{-sT/2} + y(3)e^{-2sT/2} + y(2)e^{-3sT/2} + y(3)e^{-4sT/2} \right\}$$

Figure 2-5. Partial Response System

The triangular pulse generator impulse transfer function is given by

$$T(s) = \frac{T}{2} \left[\frac{1 - e^{-s\frac{T}{2}}}{s} \right]^2 \approx \left[\frac{\omega^2}{s^2 + 2\zeta\omega s + \omega^2} \right]^2$$

and its approximation was formed by equating the first few terms of the Taylor series for each. The resulting second order transfer function is shown in Figure 2-6.

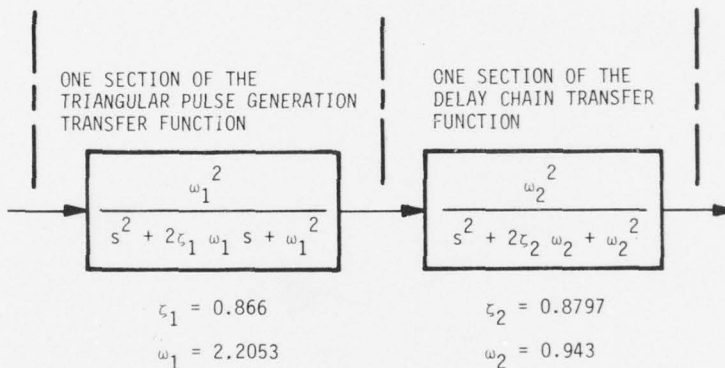

WHERE s IS SCALED TO THE FILTER CUTOFF FREQUENCY

Figure 2-6. Partial Response Filter, Transmitter, and Receiver Filter Transfer Functions

The delay chain transfer function may be rewritten from that shown in Figure 2-5, utilizing the symmetry about the peak of the partial response impulse response. If the sampled values are substituted, the response magnitude is found to be the first three coefficients of the Fourier series for the magnitude of the cosine filter.

In this light, the delay chain transfer function was formed by equating the first two forms of the Taylor series for the squared magnitude of a second order system and for the desired cosine response. The resulting second order transfer function is shown in Figure 2-6.

The mechanized filter was adjusted to give the desired impulse response. It has a base width of three symbol pulsewidths, it is essentially symmetrical about the peak, and it has minimum intersymbol interference at the third and fourth symbol pulse times. The impulse response is shown in Figure 2-4, and the gain, phase plots of the filter are shown in Figure 2-7.

AD-A067 362

MARTIN MARIETTA AEROSPACE ORLANDO FLA
HYBRID COMPUTER SIMULATION STUDIES FOR SYSTEM CONTROL AND TRANS--ETC(U)

F/6 17/2

MAR 79 J K BISHOP, M K KLUKIS

DCA100-77-C-0061

UNCLASSIFIED

OR-15438

SBIE-AD-E100 195

NL

2 OF 3
AD
A067362





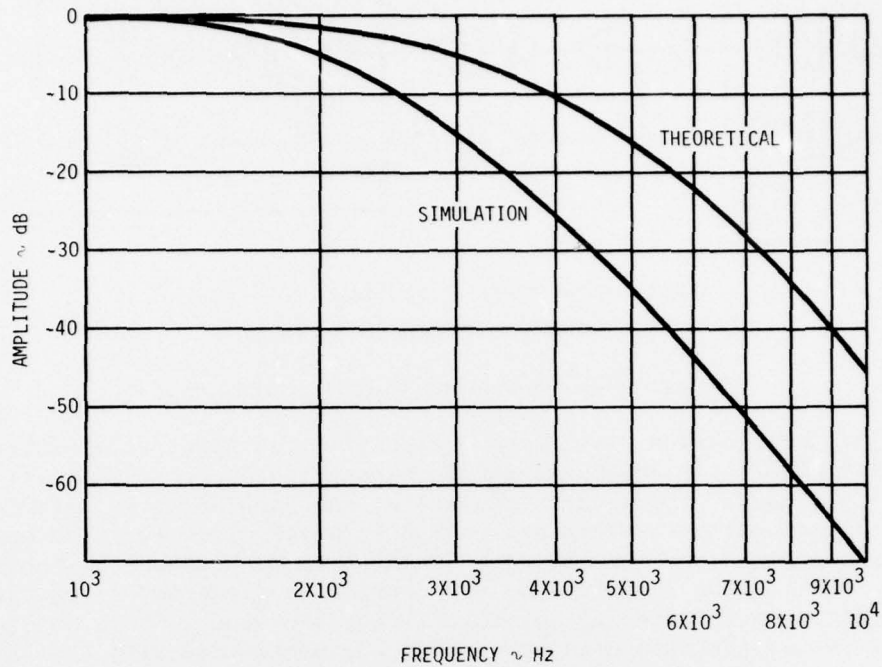
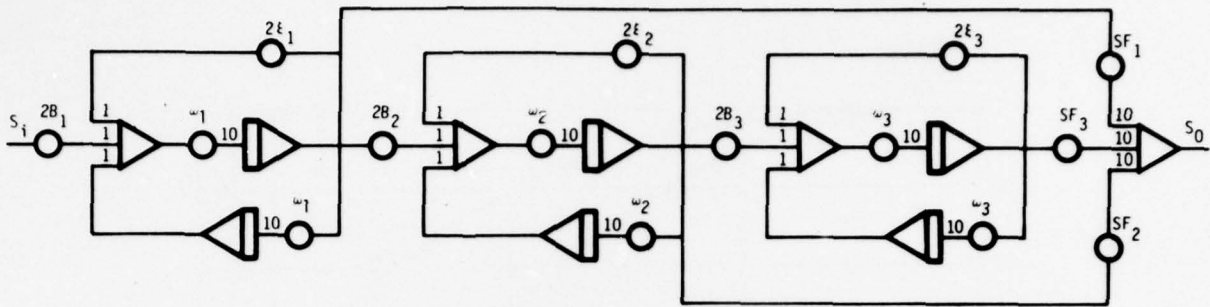

Figure 2-7. Frequency Response Plot of the Composite Partial Response Filter

If the QPSK modulation option is selected, a path is provided directly from the encoded I and Q NRZ data to the in-phase and quadrature balanced modulators.

Following the modulator section, optional spectral control bandpass filters and an optional nonlinear amplifier are simulated. Currently, these filters are programmed to permit the selection of either Butterworth or Chebychev characteristics for two, four, or six poles. The filter programmed on the analog computer is controlled digitally by the simulation user. A stagger-tuned approach is taken, where the parameters for each stage are calculated and set by the digital computer. The center frequency and bandwidth of the filter are specified by the user. The digital computer then calculates and adjusts the center frequency and bandwidth of each stagger-tuned section to produce the desired overall frequency response of the filter.

Referring to Figure 2-8, the filter parameters β , ξ , and ω of each stage represent the gain bandwidth product, bandwidth, and center frequency, respectively. SF_1 , SF_2 , and SF_3 are the scale factors that adjust the overall gain of the filter to ensure unity gain and select the order of the filter.



SIMULATES SECOND, FOURTH, OR SIXTH ORDER
CHEBYSHEV, BUTTERWORTH, OR BESSEL BANDPASS FILTER.

Figure 2-8. Bandpass Filter Simulation

The nonlinear device simulation between the two spectral limiting band-pass filters models the AM/AM and AM/PM characteristics of either TWT or Klystron amplifiers. Figure 2-9 illustrates the simulation of this function using analog computing elements and card programmed diode function generators. The modulated carrier is input to an envelope detector, which determines the time-varying amplitude of the carrier by diode-detecting the signal magnitude and filtering out the carrier frequency. This amplitude output drives two function generators that are programmed with the AM/AM and AM/PM characteristics of the given nonlinear device. The output of the AM/PM function generator determines the time constants for an analog computer programmed phase shifter that shifts the modulated carrier by the appropriate computed phase angle. The AM/AM function generator drives a gain circuit that multiplies the modulated carrier by the corresponding gain.

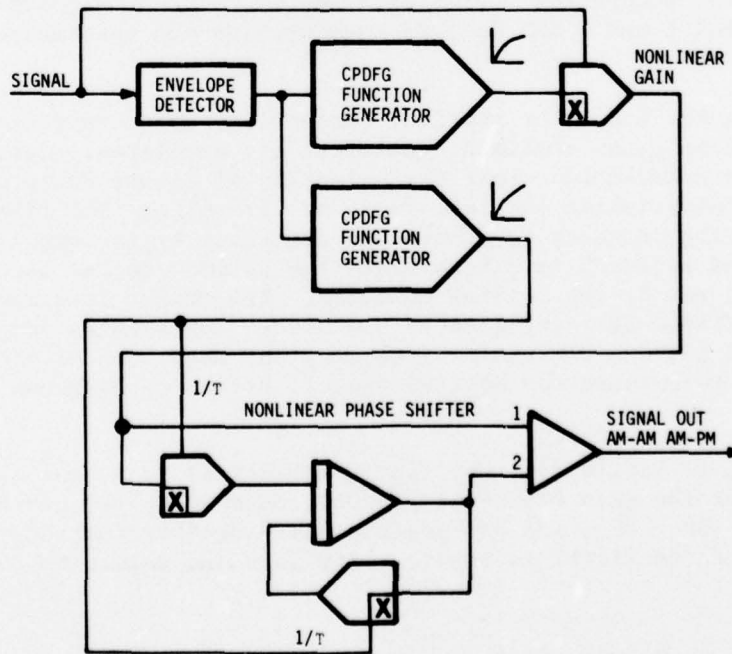

Figure 2-9. Nonlinear Device Implementation

2.1.4 QPR/QPSK Receiver Simulation

The QPR/QPSK dual diversity receiver simulation is composed of two identical receiver chains, each of which includes an IF and AGC section, modified Costas loop demodulator, two- and three-level detection, bit timing recovery, and data regeneration.

Figure 2-10 illustrates the analog computer program for one of the two identical IF and AGC sections. The simulated IF section filters and adjusts the gain of the received transmitted signal plus noise. Nominal values for the actual IF filter center frequency and bandwidth are 70 MHz and 45 MHz, which are 2681 Hz and 1723 Hz for the simulated filter. The IF bandpass filter simulated on the analog computer has been programmed to reflect the characteristics of either Butterworth or Chebychev bandpass filters with up to six poles. User programs have been developed to permit parameter changes for bandwidth, center frequency, ripple factor, and filter order. Programs for these functions, together with the calculation of the stagger-tuned stages, are addressed in paragraph 2.5, Support Software.

An AGC for each IF section has been mechanized using a full-wave rectifier, low-pass filter, divider, and multiplier. The signal from the IF output amplifier is full-wave rectified and filtered with a low-pass filter (time constant equal to five times highest fade rate) to detect the received IF amplitude. This variable is input to a divider whose ratio determines an IF gain to raise the IF signal amplitude to its nominal value. The divider output controls the gain of the output IF amplifier through a multiplier (range 0 to 60 dB).

A modified Costas loop demodulator has been simulated that accepts the IF output and coherently demodulates either QPSK or QPR, depending on user selection at the modulator. For QPR the low-pass filters following the correlation process (multiplication of IF signal with the coherent reference) are the complements to the transmit partial response filters. The transfer function used for these receiver filters in a QPR mode is:

$$H_r(s) = \frac{3.25104}{s^4 + 4.3966s^3 + 9.28835s^2 + 8.105s + 3.25104}$$

For the QPSK mode the filter is modified to approximate a full response with linear phase using a fourth order Butterworth low-pass filter, which produces a two-level baseband signal instead of the three-level signal for QPR.

The modified Costas Loop (Figure 2-11), requires the modeling of a coherent reference. To develop this reference, the filtered dc cross-coupling component of the I and Q baseband signals were used to phase-lock a local oscillator to the incoming received signal. The cross-coupling products are the result of multiplying the baseband I and Q signals with an estimation of the value (+1 for QPSK and +1, 0, -1 for QPR) of Q and I, respectively. A lead/lag filter has been mechanized to develop a $\Delta\omega$ to

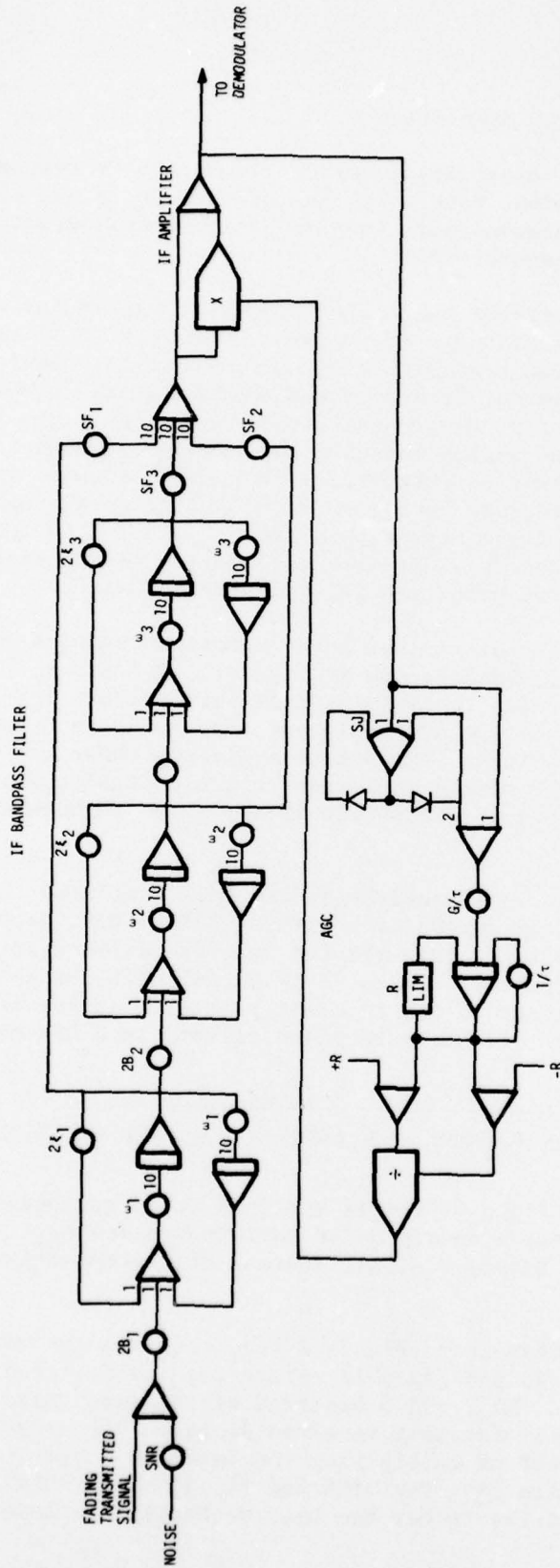

Figure 2-10. Line-of-Sight Modem IF/AGC Simulation

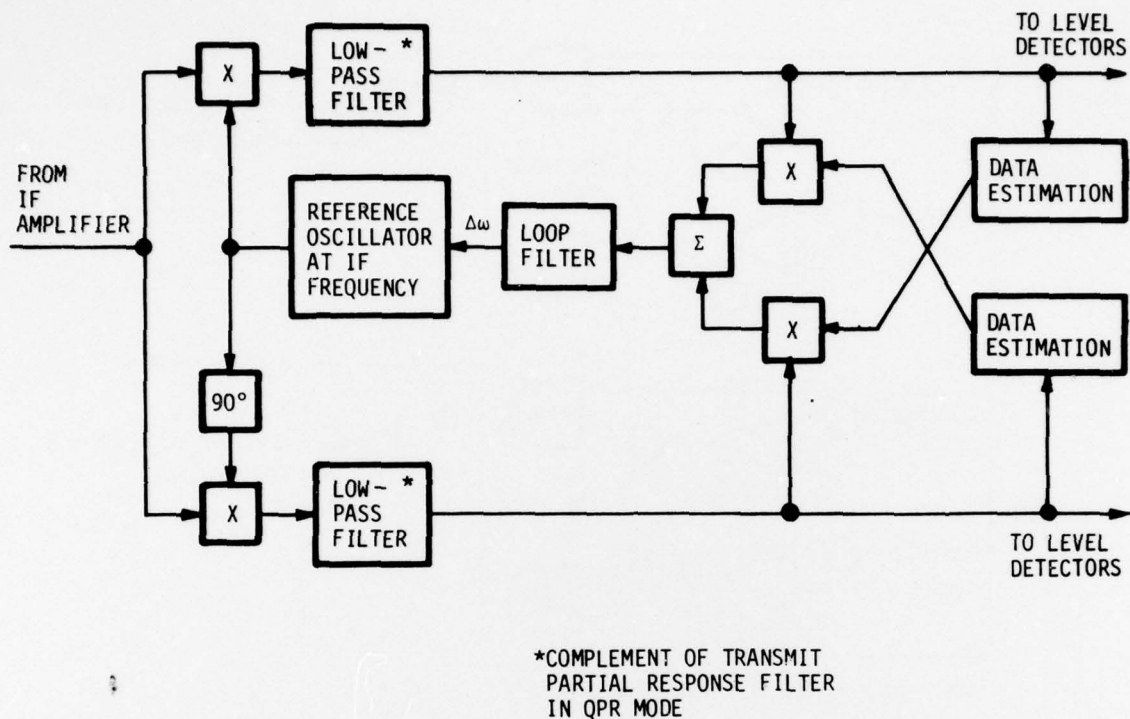
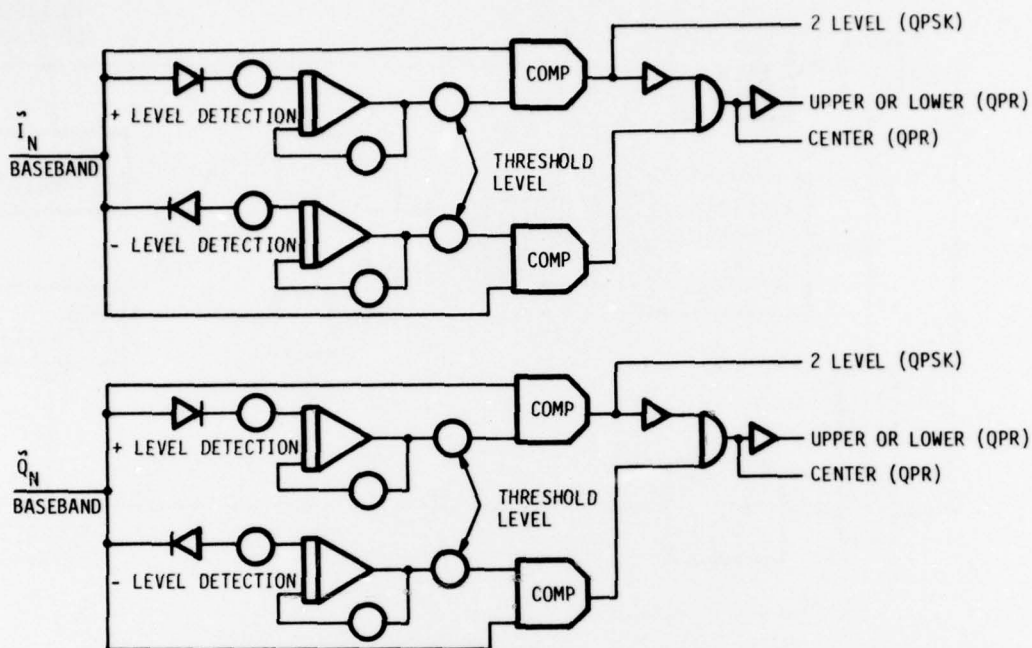

Figure 2-11. Modified Costas Loop Demodulator Model

phase-lock an analog amplitude stabilized oscillator. The lead/lag filter provides a type II second order phase-locked loop. The parameters of the filter were selected and optimized with a gain of 5, damping of 0.707, and cutoff frequency of 0.651 Hz. The sealed cutoff frequency corresponds to 17 kHz for the actual system.

To accommodate either QPSK or QPR requires both two-level and three-level detection of the baseband data. This simulation is shown in Figure 2-12. Each of the demodulated I and Q baseband signals is input to plus and minus level detectors which, combined with threshold or slicing level coefficients, form the upper and lower slicing levels. These slicing levels and the baseband signals are input to comparators for detecting the presence of +1, 0, and -1 data from the demodulated baseband signals. For QPSK, the slicing coefficients are set to zero, and only the upper comparator is used to detect the binary baseband +1, and -1.

The detected three levels for the QPR are input to logic circuits that sample the received baseband data at the instant of the zero crossover of the baseband eye, using timing from the receiver clock. For QPR, a +1 or -1 represents a recovered zero and zero represents 1. For QPSK, the baseband data is sampled during the period of maximum response; and +1 represents a recovered 1, and -1 represents zero.



NOTE: THRESHOLD LEVEL IS ZERO FOR QPSK

Figure 2-12. Two- and Three-Level Detection Simulation

Differential decoding follows in the level detection simulation if the modulation signal is QPSK. The differential decoder complements the transmitter encoder and is modeled as the modulo 2 sum of the present symbol and the previous symbol. QPR does not require decoding since it is already in a decoded state. Following the decoder, the detected QPR or decoded QPSK in-phase and quadrature symbol streams are recombined to a bit stream using a parallel-to-serial converter. If the scrambler option is selected, the bit stream is descrambled by using the inverse of the scrambling process described in paragraph 2.1.2. Timing for these functions is provided by the simulated receiver clock.

The output of the parallel-to-serial converter, or if selected the scrambler, is input to the bit error detection circuit. The error detecting circuit compares the recovered retimed receiver data and the delayed transmitter data for possible error. The recovered data is retimed with the transmitter bit rate clock to ensure that the data transitions are properly aligned. The retimed receiver data and the delayed transmitter data are compared bit by bit.

The results of the noise performance bit error tests for QPR and QPSK modulation appear in Figures 2-13 and 2-14.

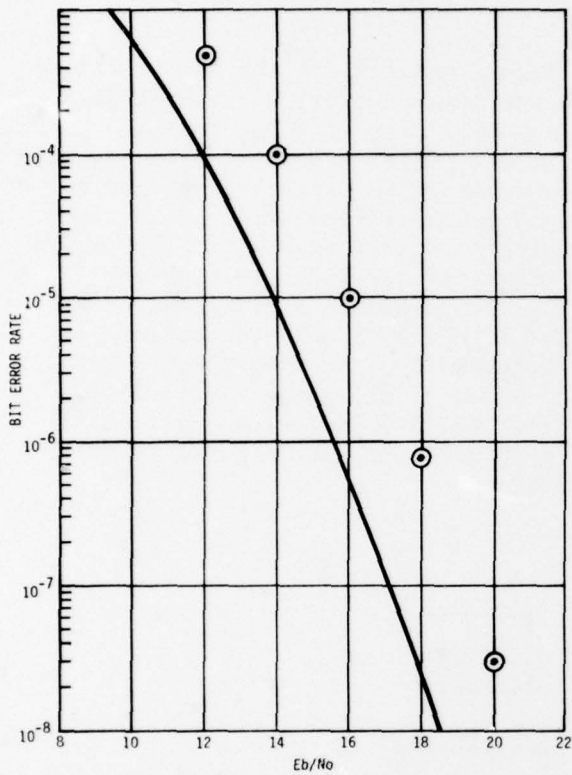
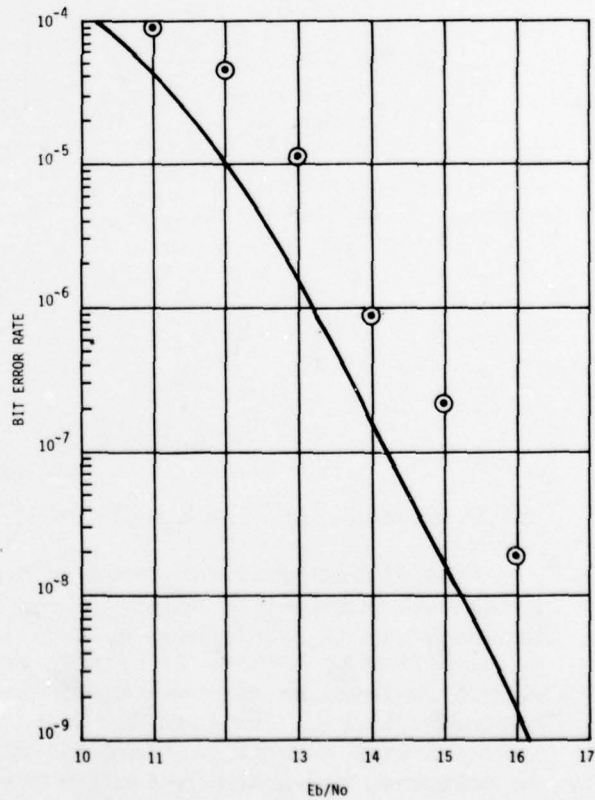

Figure 2-13. QPR Noise Performance
Bit Error Test

Figure 2-14. QPSK Noise Performance
Bit Error Test



2.1.5 Receiver Clock Simulation

A bit timing recovery circuit has been simulated for the line-of-sight modem that provides synchronization for the data recovery circuits. This model (Figure 2-15) uses an analog phase-locked loop to phase-lock a reference oscillator to one of the baseband signals. The I-channel baseband was chosen for this simulation. This baseband analog signal is sliced to produce a ± 1 square wave from which a good spectral line amplitude at the baseband frequency can be obtained by using a logical one-shot. The signal from the one-shot is analog-to-digital converted and input to a phase detector (multiplier) together with the clock reference oscillator. The resulting phase error is filtered using a lead/lag circuit to obtain a dc component, $\Delta\omega$, which phase-locks the reference clock to the received data. The lead/lag filter provides a type II, second order, phase-locked loop. The parameters of the filter were selected and optimized with a gain of 1, damping is 0.707, and a cutoff frequency of 0.651 Hz, which corresponds to an actual system cutoff frequency of 17 MHz.

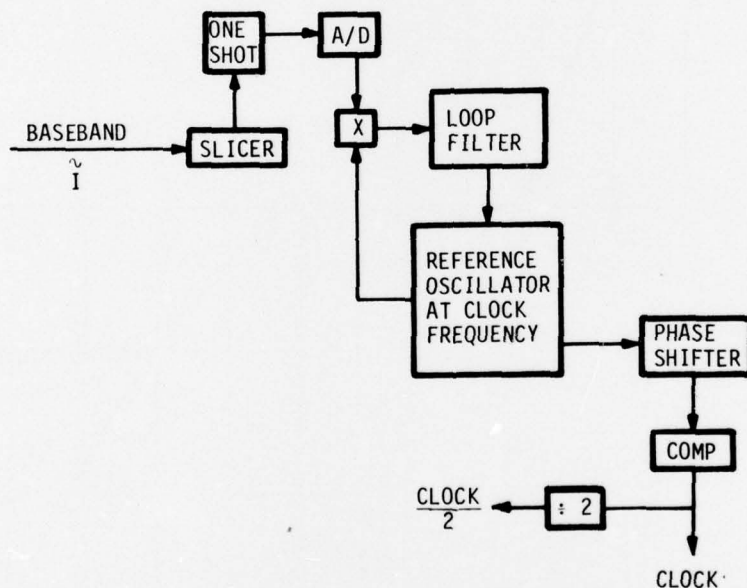

Figure 2-15. QPR/QPSK Bit Timing Recovery Model

2.1.6 Diversity Switch Simulation

The diversity switch receives a control signal from a performance assessment module that selects the best channel based on received signal and baseband signal performance criteria. The control of the diversity switch is specified by the remote hybrid terminal user. The performance evaluation module includes an eye-opening detector, or eye quality monitor, and the AGC control voltage. The user may also specify for the diversity switch to select A or B channel data exclusively. If the AGC or eye quality monitor is selected, the computer samples the bit error stream associated with the channel whose performance is best.

2.1.7 Eye Quality Monitor

The eye quality monitor measures the ability of the receiver to distinguish between the adjacent phase levels of the received baseband signal. The monitor determines if the received baseband signal lies within a band whose boundaries are defined by the eye quality threshold at the time it is sampled. The band is proportional to the peak of the received baseband signal level so that it is a measure of how good the eye is, even under fading conditions. A digital pulse is generated if the baseband signal is within the thresholds at the proper time. The digital pulse is converted to an analog signal by switching an analog dc voltage into a low-pass filter whose bandwidth is much less than the symbol rate. The voltage that is generated at the low-pass filter's output is directly proportional to how well the baseband signal approaches an ideal eye pattern. The eye quality monitor threshold levels are illustrated in Figure 2-16.

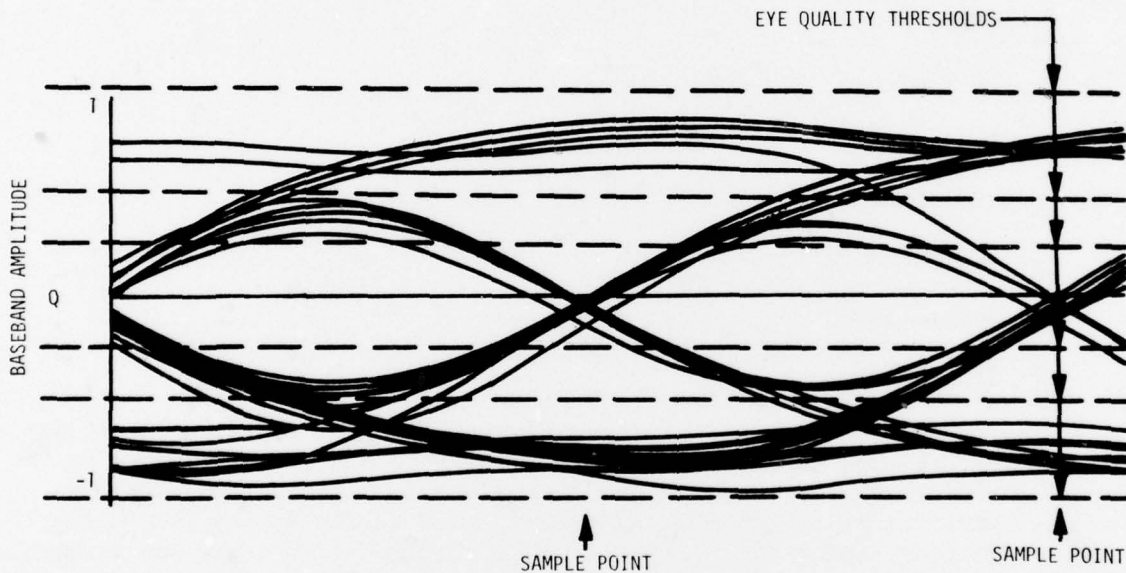

Figure 2-16. Eye Quality Monitor Thresholds

2.1.8 Four-Level FM Modulation Technique

Martin Marietta used the previously developed FM simulation for the four-level FM digital LOS modulation techniques study. The model was developed using a parallel interactive approach to communication systems modeling under DCA Contract No. DCA100-75-C-0058. The model has been validated and used in four-level FM data transmission over LOS microwave links. A functional block diagram for this four-level FM simulation is shown in

Figure 2-17. The system depicted in Figure 2-17 includes a multiplexed bit stream, Digital Applique Unit (transmit and receive), four-level FM radio (transmit and receive), and dual Rayleigh fading channels. The simulation modules making up this system are:

- 1 Timing and Synchronization
- 2 Data Generation
- 3 Encoder
- 4 Digital-to-Analog Converter
- 5 FM Modulator
- 6 Channel
- 7 Mixer
- 8 IF Stage
- 9 FM Demodulator
- 10 Bit Timing Recovery
- 11 Decoder
- 12 Descrambler
- 13 Bit Error.

The transmission chain included portions of both the Digital Applique Unit (DAU) baseband modem and FM radio. A data generator was modeled to provide the random serial bit stream from the order wire multiplexer. To generate the serial bit stream, a Gaussian noise source was sampled using the transmitter timing module. The resulting random bit stream was scrambled using a 20-stage shift register and two modulo 2 sums. The first modulo 2 sum was made of the n and $n-1$ bits of the 20-stage shift register. The result of this modulo 2 sum was modulo summed with the timed bit stream to form the shift register input. Serial-to-parallel conversion of the scrambled data was accomplished by retiming the n and $n-1$ bits of the shift register with the symbol clock, CLK 2.

The resulting parallel symbol bit streams were differentially and four-level encoded. The modeled differential encoder function was

$$A_n^* = A_{n-1}^* B_{n-1}^* B_n + A_{n-1}^* \bar{B}_{n-1}^* A_n + \bar{A}_{n-1}^* B_{n-1}^* \bar{A}_n + \bar{A}_{n-1}^* \bar{B}_{n-1}^* \bar{B}_n$$

$$B_n^* = A_{n-1}^* B_{n-1}^* A_n + A_{n-1}^* B_{n-1}^* \bar{B}_n + \bar{A}_{n-1}^* B_{n-1}^* B_n + A_{n-1}^* B_{n-1}^* \bar{A}_n$$

*represents encoded data

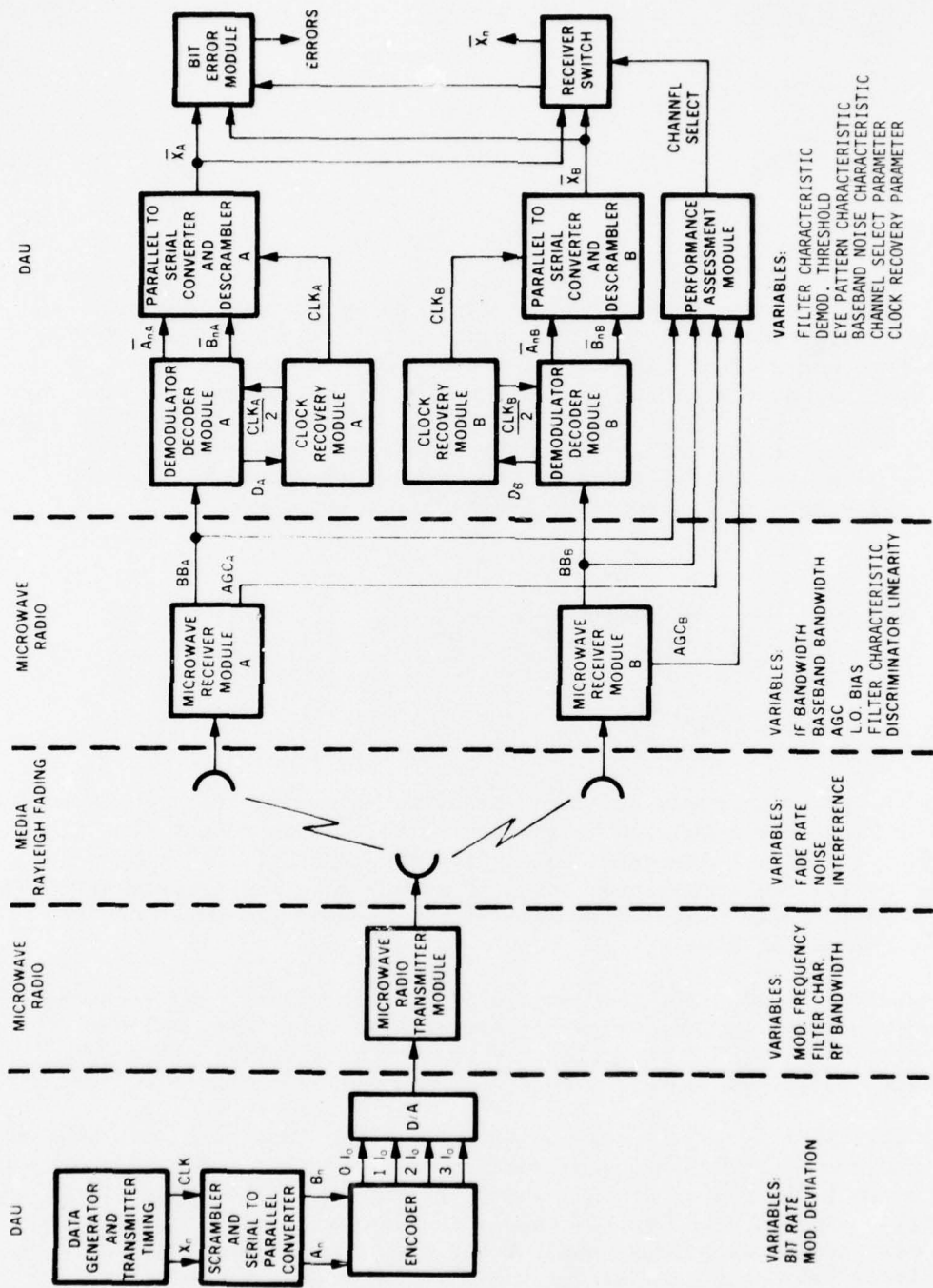

Figure 2-17. Four-Level FM Dual Diversity System Simulation

Four-level encoding of the differential encoder output was

$$01_o = \frac{\bar{A} \bar{B}}{n \ n}$$

$$11_o = \frac{\bar{A} B}{n \ n}$$

$$21_o = \frac{A \bar{B}}{n \ n}$$

$$31_o = \frac{A B}{n \ n}$$

The outputs of the four-level encoder were input to four digital to analog (D/A) switches to produce an analog four-level PAM signal at the baseband frequency. The D/A switches provide an interface between the logical and analog programming elements of the hybrid computer. This four-level baseband analog signal was then input to a third order low-pass transmitter filter. The transmitter filter was modeled as a Butterworth, and simulated, using the parallel analog programming elements of the hybrid computer. The Butterworth transfer function simulated was

$$H(s) = \frac{\omega_c^3}{(\omega_c + s)(\omega_c^2 + \sqrt{2}\omega_c s + s^2)}$$

$$\omega_o = 3 \text{ dB bandwidth}$$

The FM transmitter was simulated by using an analog voltage-controlled oscillator frequency modulated by the four-level analog output from the transmitter filter. A real-time modulation frequency of 13.056 Mb/s and deviation of 2.1 MHz (modulation index of approximately 1/6) were simulated at scaled frequencies of 652.8 Hz and 105 Hz. Center frequency of the simulated VCO was 50 kHz.

Transmitter timing for the data generator, scrambler, and encoders was simulated using the logical computing elements to count down a 1 MHz crystal clock. Real-time clock frequencies for the bit rate (26.112 Mb/s, CLK) and symbol rate (13.056 Mb/s, CLK/2) were simulated at 1.3056 kb/s and 652.8 b/s.

Two identical IF (FM radio) and baseband (DAU) receivers were modeled on the hybrid computer using a combination of analog and logical programming elements. Each FM receiver included antenna, mixer, IF bandpass filter and amplifier, automatic gain control (AGC), and limiter discriminator. The antenna was modeled as a summing point for the fading signal and additive white noise. This composite signal was mixed with a local oscillator to obtain the sum and difference frequencies. The difference frequency (IF) was filtered out using a sixth order bandpass Butterworth filter. Real-time

and simulation center frequencies of the IF were 70 MHz and 3.5 kHz. Hybrid simulation of the IF section included: analog summer amplifier for the antenna, analog multiplier for the mixer, and analog integrators, inverters, and attenuators for the Butterworth filter. The sixth order IF bandpass filter was simulated by transforming a third order low-pass prototype.

Coefficients for filter center frequency and bandwidth, and AGC bandwidth were variable. Real-time nominal values for the center frequency and bandwidth were 70 MHz and 25 MHz with the AGC bandwidth larger than the fade rate. The automatic gain control had a range of 40 dB.

The output of the IF amplifier was input to a limiter discriminator for demodulation. The limiter discriminator was modeled using a hard limiter and two tuned second order bandpass filters. Absolute values of the tuned filter outputs were differenced and low-pass filtered to extract the baseband signal. This signal was input to the receiver portion of the baseband modem (DAU) to complete the demodulation, detection, and data regeneration process. The baseband filter was a fourth order Butterworth with a bandwidth equal to the symbol rate, 13.056 Mb/s real time, and 652.8 b/s simulation time scale. Transfer function for the baseband filter was

$$H(s) = \left[\frac{\omega_c^2}{s^2 + 0.76536\omega_c s + \omega_c^2} \right] \left[\frac{\omega_c^2}{s^2 + 1.84776\omega_c s + \omega_c^2} \right]$$

$$\omega_c = 3 \text{ dB bandwidth}$$

The demodulated analog baseband signal was analog-to-digital converted into four levels using comparators to perform the level detection of the four analog signals. A data transition detector was also programmed using a high gain limit of the baseband signal (to detect zero crossing) and a comparator to convert the result to a digital square wave signal for clock recovery processing. The detected four level digital signal was decoded to obtain the received symbol data. This decoding process,

$$\bar{a}^* \bar{b}^* = \bar{m} \cdot \bar{n} \cdot \bar{o} \cdot \bar{p}$$

$$\bar{a}_n^* \bar{b}_n^* = \bar{m} \cdot \bar{n} \cdot \bar{o} \cdot \bar{p}$$

$$a_n^* b_n^* = \bar{m} \cdot \bar{n} \cdot \bar{o} \cdot \bar{p}$$

$$a^* b^* = \bar{m} \cdot \bar{n} \cdot \bar{o} \cdot \bar{p}$$

processes the four-level digital data (m, n, o, p) to obtain the differentially encoded symbol data (a_n^* , b_n^*). This decoded symbol data was differentially decoded to recover the raw parallel symbol data. Equations for the differential decoder were

$$a_n = a_{n-1}^* b_{n-1}^* b_n^* + a_{n-1}^* \bar{b}_{n-1}^* a_n^* + \bar{a}_{n-1}^* b_{n-1}^* \bar{a}_n^* + \bar{a}_{n-1}^* \bar{b}_{n-1}^* \bar{b}_n^*$$

$$b_n = a_{n-1}^* b_{n-1}^* a_n^* + a_{n-1}^* \bar{b}_{n-1}^* \bar{b}_n^* + \bar{a}_{n-1}^* b_{n-1}^* b_n^* + \bar{a}_{n-1}^* \bar{b}_{n-1}^* \bar{a}_n^*$$

Both decoding processes were programmed using logical elements of the hybrid computer. The resulting simulations were similar in structure to those illustrated for the encoding process. The next step in the digital signal processing of the baseband data was parallel to serial conversion of the symbol data, (a_n , b_n). This was accomplished by properly gating the a_n and b_n signals to set and reset a flip-flop. The output of the flip-flop represented the recovered, scrambled serial bit stream. This bit stream was descrambled by an inverse of the scrambling process to obtain the recovered raw data. The descrambler consisted of a 20-stage shift register and two modulo 2 sums programmed using parallel logical computing elements of the hybrid computer. Timing for the data regeneration circuits was derived from the receiver clock. The clock recovery model and simulation are described below.

A type II second order analog phase-locked loop (PLL) was mechanized to phase-lock an analog voltage controlled oscillator (VCO) to the recovered data. Transitions of the recovered analog baseband signal were detected using a high gain limiter. The limiter output was input to a one shot, adjusted to provide a good spectral line amplitude at the symbol rate. This square wave was mixed with a reference sine wave, 30 MHz plus symbol clock frequency (SCF), and very narrow bandpass filtered to remove the symbol and spurious components, leaving a clean MHz reference. The resulting 30 MHz reference was again mixed with the reference sine wave (30 MHz + SCF) and low-pass filtered ($\omega_c = \text{CLOCK}/2$) to obtain the receiver symbol clock. This recovered symbol clock was input to a phase detector along with the receiver bit rate clock to phase-lock the bit rate clock to the recovered bit stream.

2.1.9 Eight-PSK Modulation Technique

Figure 2-18 is a block diagram of the 8-PSK transmission system. The major difference in the implementation of the 8-PSK modulation technique and the QPSK modulation technique is the number of encoded parallel bit streams. The 8-PSK modulation/demodulation technique uses two QPSK modulators/demodulators in parallel and a $\pi/4$ phase shifter.

The serial-to-parallel converter is different from QPSK in the sense that there are three parallel symbol streams generated instead of two. The simulation design of the symbol clock generation and the serial-to-parallel converter circuitry appear in Figure 2-19. The output of the serial-to-parallel converter is encoded and input to the 8-PSK transmitter modulator module.

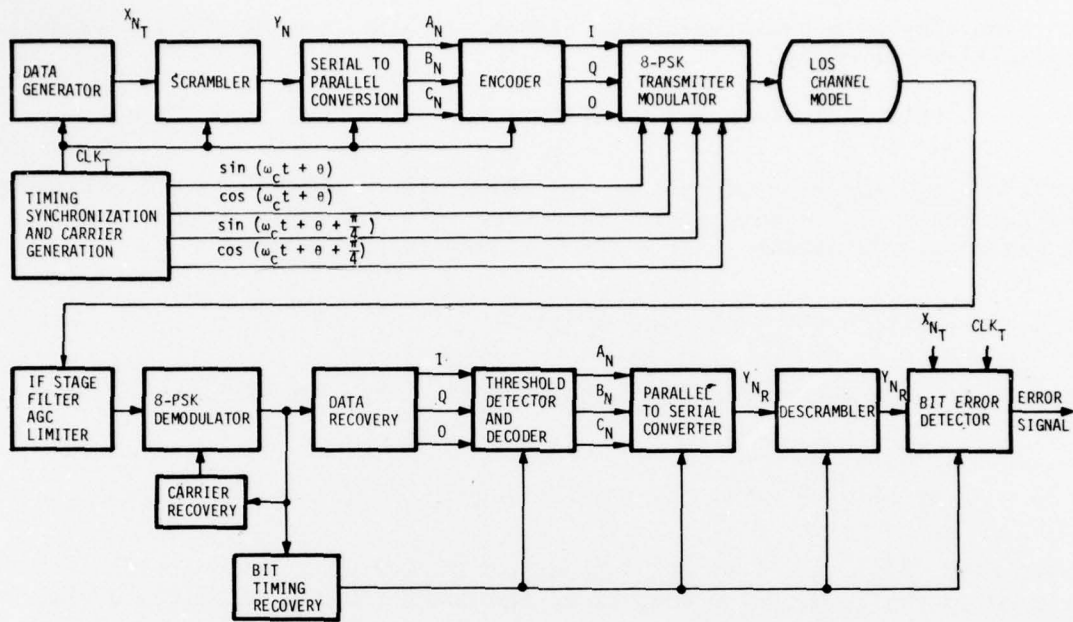

Figure 2-18. 8-PSK Digital Modulation Technique

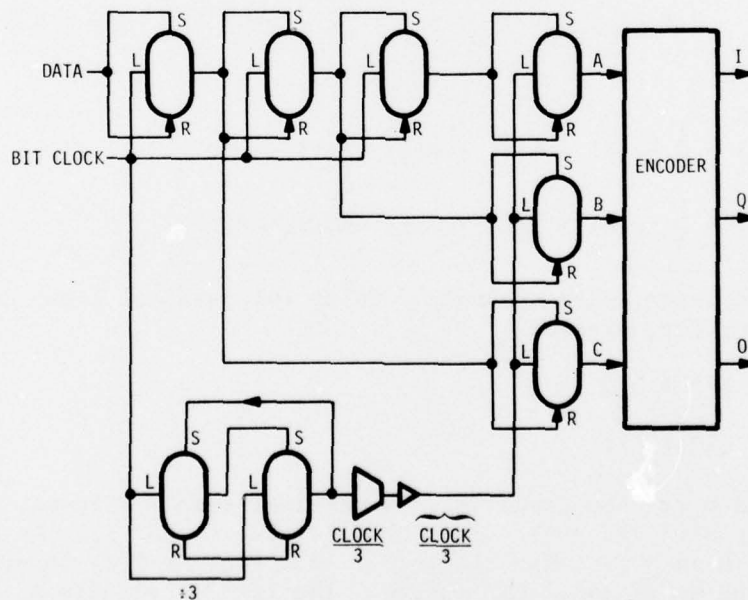

Figure 2-19. 8-PSK Serial-to-Parallel Converter

The digital n-phase modulated signal, without considering filtering, may be represented by

$$s(t) = \sin (\omega_c t + \theta + \phi(t))$$

where the amplitude is normalized for simplicity's sake, θ is the arbitrary carrier phase, ω_c is the carrier frequency in radians per second, and $\phi(t)$ is the phase modulation. For 8 PSK the expression becomes:

$$s_8(t) = \sin (\omega_c t + \theta + \frac{\pi}{8} F_8(t))$$

where $F_8(t)$ has values of $\underline{+7}$, $\underline{+5}$, $\underline{+3}$, and $\underline{+1}$. This equation may be expressed as:

$$s_8(t) = \frac{1}{\sqrt{2}} \{A(t) \cos (\omega_c t + \theta + \frac{\pi}{8} C(t) + B(t) \sin (\omega_c t + \theta + \frac{\pi}{8} C(t))\}$$

where $A(t)$, $B(t)$, and $C(t)$ are independent rectangular pulse trains directly related to the I, Q, and O outputs of the encoder and have values of $\underline{\pm 1}$.

This equation expands to:

$$s_8(t) = \frac{1}{\sqrt{2}} \sqrt{1 - \frac{1}{2}} \{A(t) \cos (\omega_c t + \theta) + B(t) \sin (\omega_c t + \theta) + D(t) \cos (\omega_c t + \theta + \frac{\pi}{4}) + G(t) \sin (\omega_c t + \theta + \frac{\pi}{4})\}$$

where

$$D(t) = \frac{1}{2} \{A(t) - B(t) + C(t) [A(t) + B(t)]\}$$

$$G(t) = \frac{1}{2} \{A(t) + B(t) + C(t) [A(t) - B(t)]\}$$

The above expression, when mechanized using the parallel logic capability of the analog computer, becomes:

$$D = I \cdot O + \bar{O} \cdot \bar{Q}$$

$$G = Q \cdot O + \bar{O} \cdot I$$

here I, Q, and O are the three encoded parallel symbol streams, and D and G are related to $D(t)$ and $G(t)$. If D or G is true (logic 1), the $D(t)$ or $G(t)$ is +1, and if D or G is false (logic 0), then $D(t)$ or $G(t)$ is -1. Figure 20 illustrates the 8-PSK modulator module. The logical signals A, B, D, and G control the sign of the carrier phase signals $\cos (\omega_c t + \theta)$, $\sin (\omega_c t + \theta)$, $\cos (\omega_c t + \theta + \pi/4)$, and $\sin (\omega_c t + \theta + \pi/4)$, respectively. These signals are summed to form the 8-PSK modulated signal.

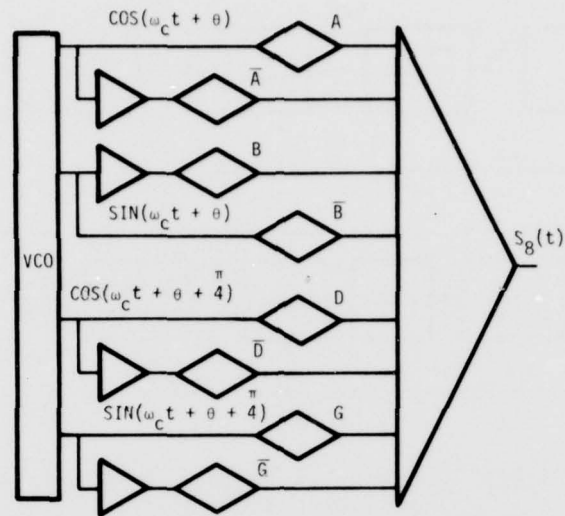

Figure 2-20. 8-PSK Modulator Module Implementation

The remainder of the 8-PSK system is the same as the QPSK system until the signal path is demodulated. The method selected to demodulate the received signal was the technique of data estimation using a modified Costas loop for carrier recovery similar to the QPSK system. The 8-PSK demodulation technique requires two QPSK demodulators in parallel. There are four phase detectors, which are implemented using analog multipliers and whose inputs are the IF/AGC module output multiplied by the recovered carrier signals. The recovered carrier signals are $\cos(\omega_c t + \theta + \epsilon)$, $\sin(\omega_c t + \theta + \epsilon)$, $\cos(\omega_c t + \theta + \pi/4 + \epsilon)$, and $\sin(\omega_c t + \theta + \pi/4 + \epsilon)$, where ϵ is the phase error.

The phase error, ϵ , estimation technique was modeled using techniques from the QPSK system. The output of the baseband signals that are in quadrature were limited, crossmultiplied, and summed to form a signal proportional to phase error or orthogonality error between the two quadrature channels. A signal proportional to the error in the other two orthogonal channels was also detected and both summed to generate the total phase error, ϵ , estimate. The phase error estimate was input to a voltage control oscillator (VCO) through a type II phase-locked loop to synchronize the oscillator and to recover the carrier signal. The recovered carrier signal was phase shifted by $\pi/2$ to generate two of the orthogonal components for the phase detectors. These two signals were then shifted by $\pi/4$ to provide the other two recovered carrier signals for the phase detector multipliers.

2.1.10 Three-Level FM Partial Response Digital Modulation Technique

The three-level FM partial response digital modulation technique block diagram appears in Figure 2-21. The simulation design has been developed

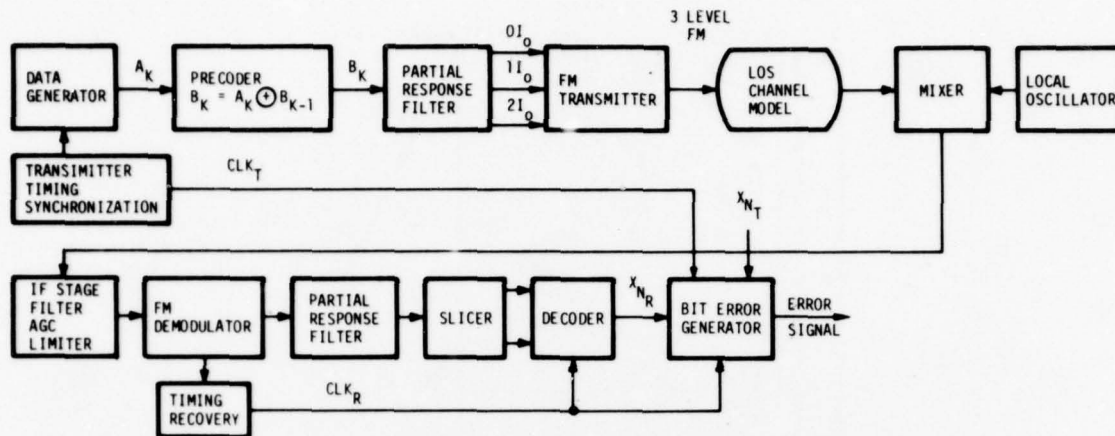

Figure 2-21. Three-Level Partial Response Digital Modulation Technique

based on that flow diagram based on previously developed techniques delineated in the preceding sections. The simulation modules making up these sections are:

- 1 Transmitter Timing and Synchronization
- 2 Data Generator
- 3 Precoder
- 4 Partial Response Filter
- 5 FM Transmitter
- 6 LOS Channel Model
- 7 Mixer
- 8 IF Stage
- 9 FM Demodulator
- 10 Partial Response Filter
- 11 Slicer
- 12 Decoder
- 13 Bit Timing Recovery
- 14 Bit Error

The FM transmitter module simulation design was developed using an amplitude stabilized analog VCO frequency modulated by the output of the partial response filter. The Class I partial response filter was mechanized as two equal filters, one as the transmitter baseband filter and the other as the receiver baseband filter. The transfer function for the partial response filters is:

$$\frac{3.25104}{s^4 + 4.3966s^3 + 9.28835s^2 + 8.105s + 3.25104}$$

The IF stage includes the IF filter, AGC circuit, and IF limiter. The IF filter is mechanized as a sixth order Butterworth bandpass filter. The center frequency bandwidth and order of the filter are selectable by the remote user. The AGC circuit was mechanized using the techniques developed for the QPR simulation and IF limiter, which was mechanized using an analog limiter set to its appropriate value to eliminate the IF amplitude variation.

The demodulator module simulation methodology was developed using a PLL technique for demodulation. The demodulator module is made up of an input phase detector, loop filter, amplifier, and VCO. The phase detector was simulated an analog multiplier whose inputs are the output of the IF module and the VCO.

The basic operation of the demodulator requires the loop to track the phase of the input signal. This appears in the mechanization as a voltage proportional to the phase error at the output of the phase detector. This error is then filtered, amplified, and input to the VCO to track the input signal. Frequency synchronization and tracking are achieved by tracking the signal phase.

The loop is a third order, type one, phase-locked loop. The filter was mechanized using two first order low-pass filters whose composite transfer function is

$$\frac{4.24 \times 10^8}{(s + 4000)(s + 120000)}$$

The demodulator output signal is routed to the received partial response filter that formed the three-level baseband signal. This signal is sliced and converted to a digital logic parallel symbol stream. The output of the slicer module is then decoded to reform the data stream.

2.1.11 DAR Digital Troposcatter Modem Simulation

The mechanization of the DAR digital troposcatter modem simulation has been developed, checked out, and its performance verified by DCEC personnel using the remote hybrid terminal. The description of the simulation was presented in detail in the interim report for the period from September 1977 to June 1978.

Bit error tests were run by DCEC personnel to compare the performance of the system with theoretical probability of error performance curves. The curve in Figure 2-22 compares the noise performance of the system to the theoretical bit error probability curve. Figure 2-23 illustrates the bit error performance of the Rayleigh fading channel. The performance of the system was evaluated for several different troposcatter channel configurations. Runs were made for various different path lengths of 100 to 250 miles. DCEC personnel have the results of those studies. As an example, the results of the bit error test for the troposcatter channel profile for a path length of 250 miles, an antenna beamwidth of 0.6 degree, smooth earth, and an effective earth of 1.33 are illustrated in Figure 2-24.

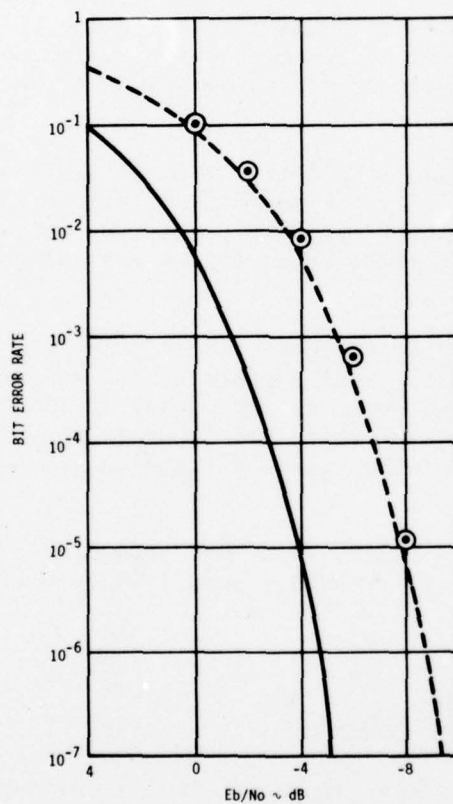

Figure 2-22. DAR Noise Performance Bit Error Test

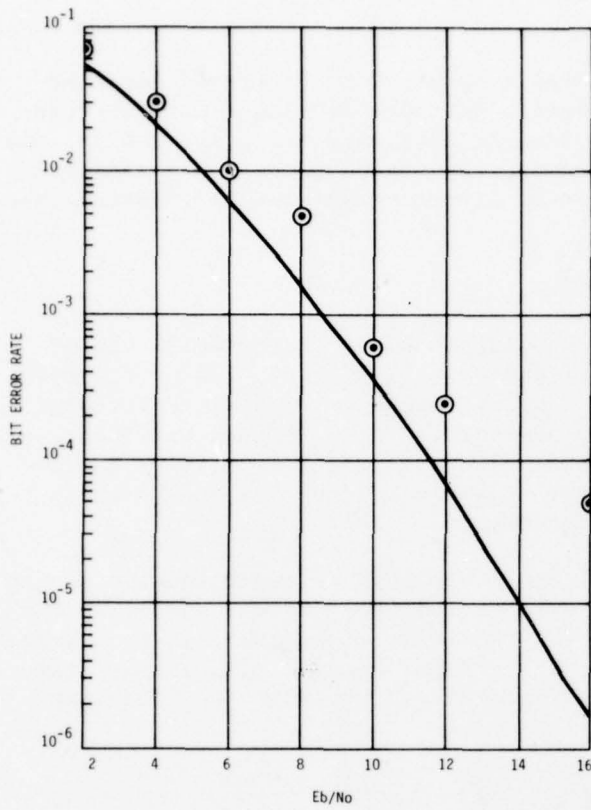

Figure 2-23. DAR Rayleigh Channel Bit Error Test

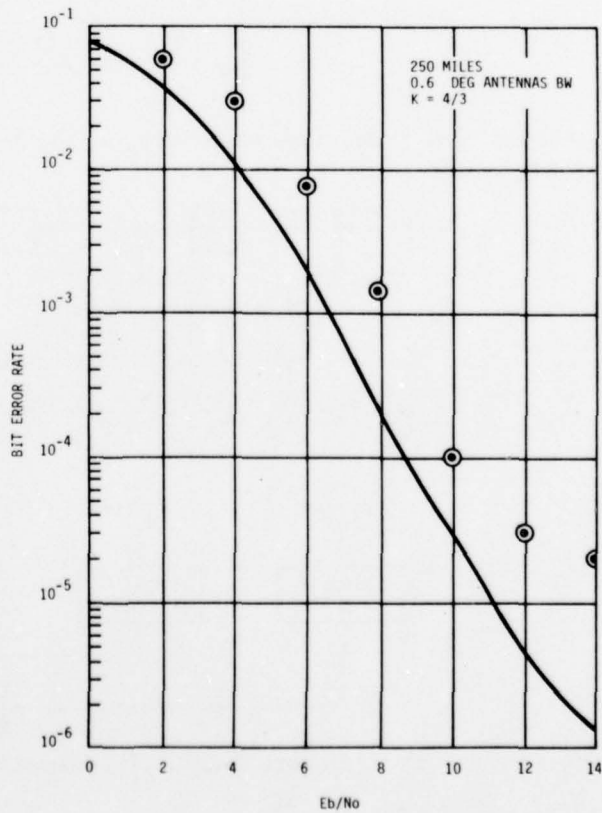

Figure 2-24. DAR Troposcatter Channel Bit Error Test

2.2 Fading Channel Simulation

A fading channel simulation using a combination of hybrid computer technology and integrated circuit design has been developed for line-of-sight frequency flat fading, line-of-sight frequency selective fading, and troposcatter frequency selective fading. By changing the tap coefficients (delay profile), up to four channels of line-of-sight fading or tropospheric scattering can be performed.

2.2.1 Tropospheric Scatter Simulation

A troposcatter fading channel simulation based on the Bello troposcatter channel model has been developed. The implementation of the model is unique in that the analog delay lines utilize state-of-the-art charge coupled devices (CCDs) as the delay elements. This approach was chosen over more common digital techniques because of the inherent simplicity and the higher obtainable bandwidth. The devices selected for the delay lines permit the delay of simulated frequencies to 20 kHz.

The Bello troposcatter channel model provides an approximation of the average multipath and fading properties of the troposcatter channel. The channel model (Figure 2-25) utilizes a tap delay line with taps at intervals of $\gamma=1/W$, where W is the bandwidth of the input signal. The output from each tap is multiplied by a complex Gaussian process with the following correlation properties:

$$G_i^*(t) G_j(t) = \begin{cases} \frac{Q(i, W)}{W} & \text{for } i = j \\ 0 & \text{for } i \neq j \end{cases}$$

where i and j are tap positions, n is the total number of taps, and Q is the delay power profile.

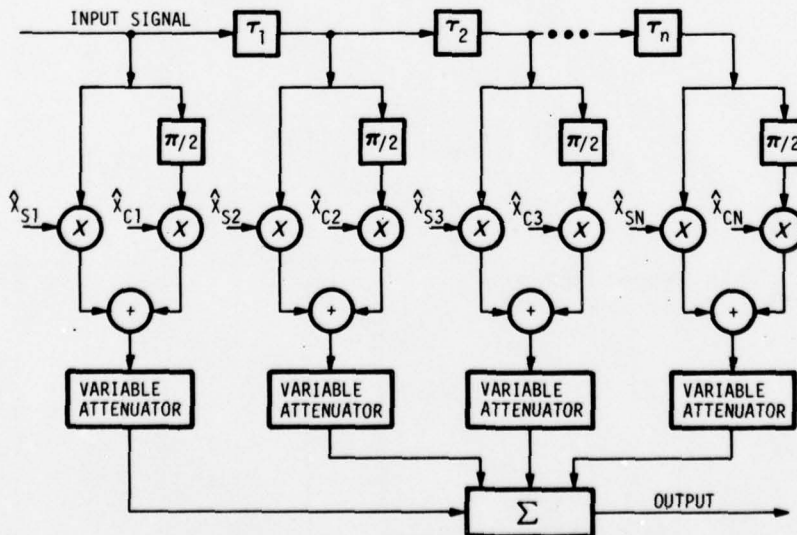

Figure 2-25. Troposcatter Channel Model

The complex gain of each tap is an uncorrelated Gaussian process, the variance of which is proportional to the delay power profile, evaluated at the position of that particular tap. The outputs of the multipliers are then summed to form the simulated channel output. Four such uncorrelated channels are programmed to allow detailed study of channel effects in diversity transmission systems.

The simulator is made up of three elements: a delay line module, a digital filter module, and a multiplier-summer module. The troposcatter simulation module allows the user to change the channel fade rate, signal-to-noise ratio, and path parameters. A block diagram of the simulated channel model is shown in Figure 2-26.

The delay line module is a special purpose device integrated into the hybrid computer system. It consists of CCD integrated circuits, interconnection and tap output filtering circuits, clocking circuits, and a power supply. The clock frequency was chosen to provide an appropriate delay between the taps. For this application, a 10 kHz signal with a bandwidth of 2 kHz and a clock frequency of 512 kHz gives a delay of 500 μ s per tap ($1/W$) and 50 samples per cycle. Each tap output has been filtered to remove sampling noise. The channel simulator has two delay lines, each having up to 12 taps. Delay line 1 is the in-phase tapped delay line, while the quadrature delay, line 2, contains an additional $\pi/2$ at each tap.

The digital filter module has been implemented on the hybrid computer system's digital computer. This computer provides the resources to generate 96 uncorrelated random noise sequences, filter them, and transfer the resulting signals to the multiplier summer module. The 96 random noise sequences are generated by sampling a wideband analog Gaussian noise source with an analog-to-digital converter. Capability exists to provide correlation between adjacent random noise sequences by decreasing the bandwidth of the sampled Gaussian noise source. The digital filters are each second order Butterworth types with a nominal cutoff frequency equal to the fade rate and a maximum sample frequency of 40 samples per second. The cutoff frequency can be selected by the user at DCEC. The 96 Gaussian noise output signals from the digital filter are multiplied by the attenuation coefficient, $Q(i,W)$, at that tap and then input to the digitally controlled attenuators in the multiplier-summer module.

The multiplier-summer module consists of 4 channels, each of which contains 12 pairs of digitally controlled attenuators (one pass per delay line tap) and a summing amplifier. One attenuator in each pair multiplies the signal from one of the taps in delay line 1 by one of the Gaussian functions, $G_i(t)$, while the other attenuator multiplies the signal from the corresponding tap of delay line 2 (which is delayed an additional $\pi/2$ radians) by another Gaussian function, $G_j(t)$. The output of the 12 attenuator pairs is then summed by an analog summing amplifier network to provide the final channel output.

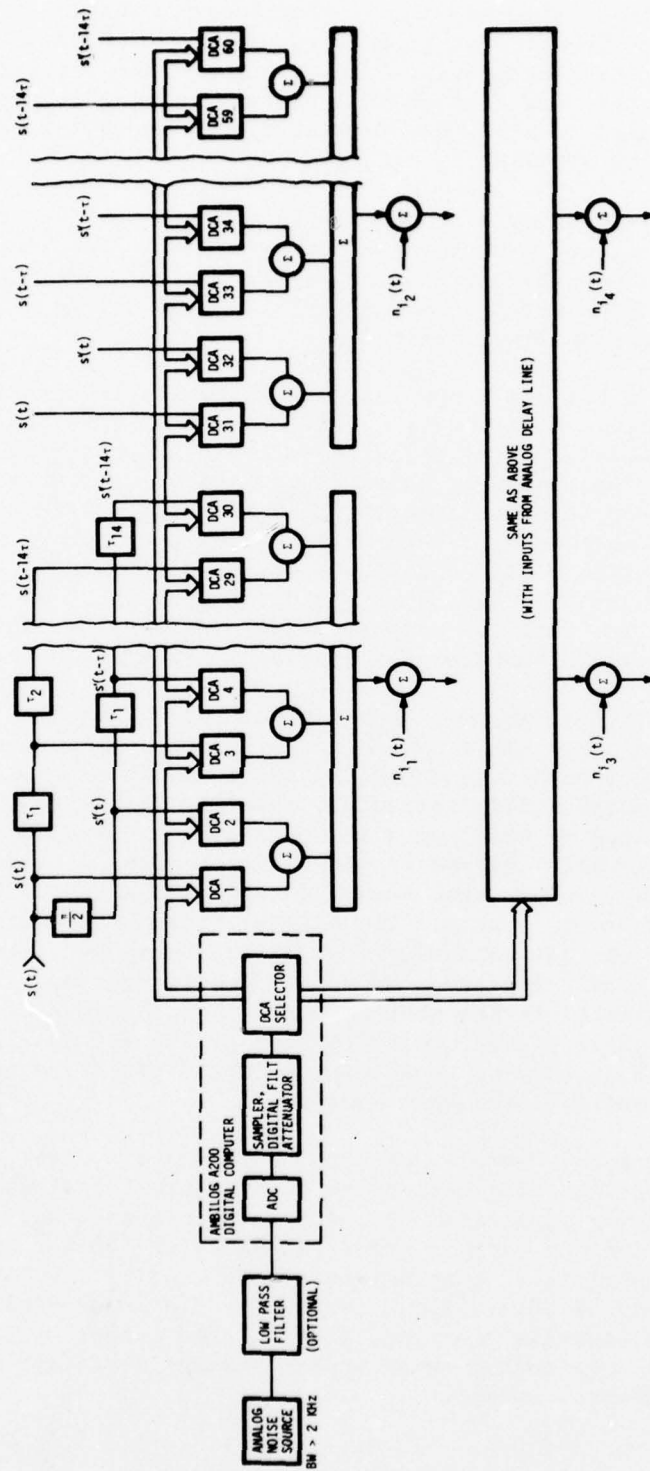

Figure 2-26. Troposcatter Channel Model Implementation

The user specified variables for the troposcatter channel simulation are rms fade rate (0.0001 to 1 Hz) and path parameters (length, antenna size, elevation angles, and effective radius). User interaction with setting up the path profiles, fade rates, and profile displays are discussed in paragraph 2.3.

2.2.2 Line-of-Sight Multipath Channel Simulation

A line-of-sight multipath fading channel was simulated using the technology developed for the troposcatter channel model. The difference between the troposcatter and the multipath line-of-sight channel models is in the delay line module and the multiplier-summer module. The clock frequency of the delay line module can be varied, permitting tap delays of 0.25 to 2.0 bits. The variable attenuation profile of the multiplier-summer module may be specified and entered by the user for each of the 12 taps.

2.2.3 Line-of-Sight Rayleigh Fading

A line-of-sight Rayleigh flat fading channel can be configured easily from the simulated troposcatter simulation. By setting the coefficients of the first tap pair in each channel to one and turning all other taps off, four Rayleigh flat fading channels can be obtained. Parameters set by the user in this mode include the fade rate and diversity selection.

2.2.4 Channel Test and Validation

Testing and validation of the troposcatter and Rayleigh channel simulations has been performed by measuring the characteristics of each pair of taps. Each pair of taps (in-phase and quadrature) should have a Rayleigh distribution that can be measured by counting the percentage time the median signal levels is above a range of the signal levels. For the test documented in Table 2-1, this range was +8 dB to -20 dB in 4 dB increments. The plot of the Rayleigh distribution for tap 1 channel 1 appears in Figure 2-27. The complete results for each of the taps in each channel appear in Table 2-1.

2.3 Electromagnetic Vulnerability Simulation

Hybrid computer programs have been designed to simulate electromagnetic vulnerability for several types of interferers. These interferers may be selected and specified as an option of the user for both troposcatter and line-of-sight techniques. The interference types include:

- 1 Tone interference
- 2 Noise block interference
- 3 Delayed replica interference.

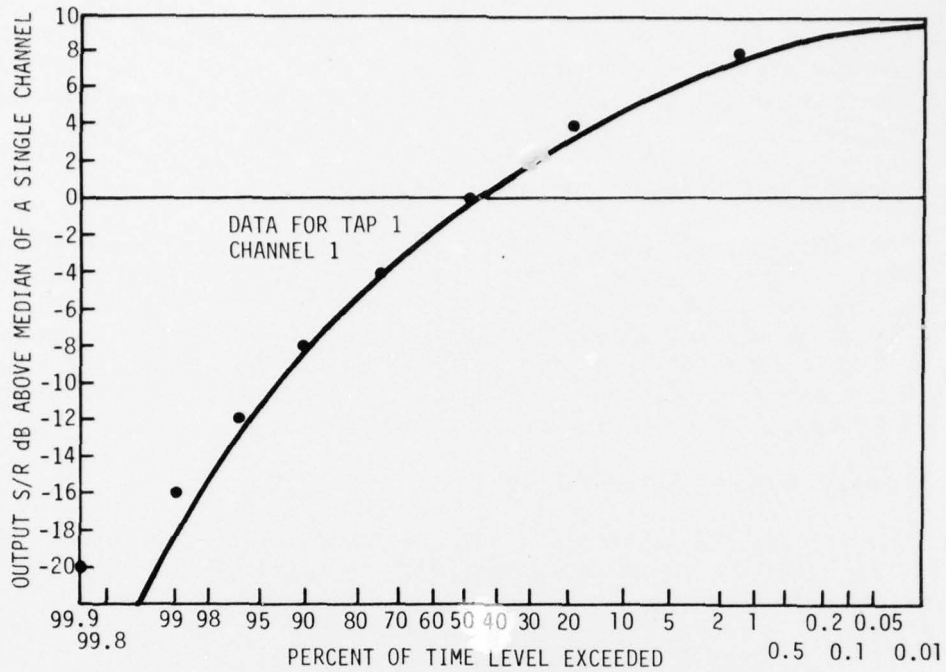

Figure 2-27. Rayleigh Fading Distribution

The tone interference source was simulated by programming an analog amplitude stabilized VCO with variable frequency coefficient. The center frequency, ω_0 , and signal-to-interference ratio are parameters that may be specified by the user through the remote hybrid terminal. The simulation has the capability of providing FM interference by adding an FM modulating signal to the VCO. The modulating signal is supplied by a low-frequency sine wave generator. Figure 2-28 is the block diagram.

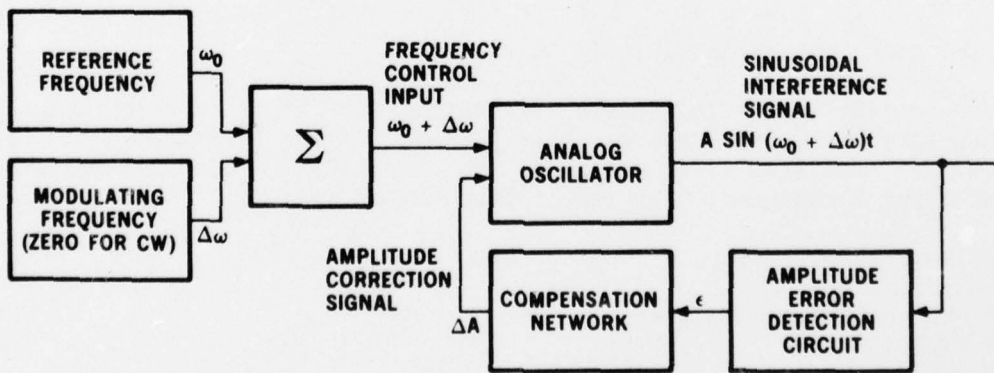

Figure 2-28. Tone or FM Interference

TABLE 2-1. RAYLEIGH CHANNEL MEASUREMENTS

Channel 1												
Percent Time Level Exceeded												
	TAP 1	TAP 2	TAP 3	TAP 4	TAP 5	TAP 6	TAP 7	TAP 8	TAP 9	TAP 10	TAP 11	TAP 12
+ 8	3.174	2.710	6.958	4.639	7.373	5.664	6.543	9.692	3.687	4.004	8.008	4.395
+ 4	25.293	22.485	30.396	23.169	32.983	25.562	29.150	32.690	22.925	23.975	32.788	23.438
0	49.805	48.413	53.149	46.826	55.151	51.392	53.589	56.689	48.218	47.754	60.645	45.337
- 4	72.192	71.021	74.438	70.459	75.610	73.169	73.682	77.197	71.509	69.727	79.639	66.235
- 8	87.427	85.083	87.915	84.985	87.769	85.303	87.207	89.453	86.157	83.301	90.332	80.542
-12	93.579	92.749	93.188	92.456	93.237	91.309	93.701	94.971	93.164	90.82	94.922	89.331
-16	96.826	96.240	96.313	96.240	96.509	94.775	96.753	97.705	96.582	95.435	97.656	94.629
-20	98.633	98.560	98.584	98.315	98.438	97.021	98.584	99.097	98.486	98.047	98.901	97.729
-24	99.390	99.365	99.341	99.243	99.414	98.218	99.365	99.683	99.487	99.243	99.463	98.926
Signal Level Above Median												
Channel 2												
Percent Time Level Exceeded												
	TAP 1	TAP 2	TAP 3	TAP 4	TAP 5	TAP 6	TAP 7	TAP 8	TAP 9	TAP 10	TAP 11	TAP 12
+ 8	8.569	6.909	4.81	7.104	5.933	5.005	7.202	6.030	1.709	5.029	5.127	6.860
+ 4	33.984	27.954	27.441	27.808	30.542	28.223	29.736	27.930	10.645	27.417	31.128	31.421
0	57.666	53.442	54.272	51.245	55.640	54.785	53.516	52.124	26.318	50.732	55.396	54.419
- 4	78.516	72.925	76.123	70.581	75.610	75.171	75.146	72.998	44.336	71.362	77.002	75.122
- 8	90.552	85.986	88.013	84.326	88.525	86.768	88.867	86.279	59.790	86.060	89.185	87.964
-12	95.654	92.627	94.604	92.896	94.165	92.920	95.068	93.530	71.436	93.164	95.190	94.873
-16	97.656	96.167	97.437	96.631	97.241	96.460	97.900	96.973	81.909	96.313	97.266	97.461
-20	99.072	98.315	98.975	98.779	98.706	98.511	99.341	98.560	89.526	98.462	98.462	98.999
-24	99.683	99.463	99.634	99.731	99.414	99.243	99.683	99.365	94.189	99.390	99.268	99.512

TABLE 2-1. (CONTINUED)

Channel 3												
Percent Time Level Exceeded												
	TAP 1	TAP 2	TAP 3	TAP 4	TAP 5	TAP 6	TAP 7	TAP 8	TAP 9	TAP 10	TAP 11	TAP 12
+ 8	4.956	7.251	4.761	5.908	6.982	4.468	5.688	8.325	7.300	5.078	6.836	4.102
+ 4	24.170	28.882	28.198	28.271	30.981	29.272	29.468	31.519	33.13	27.979	30.566	26.855
0	50.342	50.562	52.856	52.759	52.979	54.150	55.762	56.934	54.81	51.758	55.371	48.901
- 4	72.241	71.802	75.586	73.999	72.705	76.196	77.124	77.051	74.414	71.631	75.122	71.338
- 8	85.864	86.108	88.916	87.671	84.790	89.722	89.551	88.257	87.354	85.620	88.330	86.060
-12	92.529	93.628	94.824	94.116	91.528	95.166	95.264	93.945	94.189	93.579	94.36	93.726
-20	98.291	98.486	99.292	98.584	97.461	99.316	99.194	98.804	98.853	98.657	98.706	99.390
-24	99.194	99.316	99.902	99.219	98.584	99.805	99.658	99.585	99.536	99.536	99.292	99.829
Channel 4												
Percent Time Level Exceeded												
	TAP 1	TAP 2	TAP 3	TAP 4	TAP 5	TAP 6	TAP 7	TAP 8	TAP 9	TAP 10	TAP 11	TAP 12
+ 8	5.589	4.639	7.129	6.592	5.615	6.006	7.397	6.323	4.102	5.493	5.884	4.370
+ 4	27.197	28.589	27.979	25.342	26.123	29.370	29.492	31.177	23.438	28.052	29.492	22.192
0	49.854	54.395	52.124	50.342	49.414	56.201	52.515	56.763	49.048	55.566	52.539	47.705
- 4	70.459	75.269	75.488	71.606	72.021	75.952	72.754	76.782	70.776	75.269	75.684	70.337
- 8	84.229	87.354	89.282	84.619	87.158	89.063	86.768	88.379	85.327	88.599	87.549	84.546
-12	91.504	93.140	95.508	92.236	94.092	95.166	93.115	94.458	92.407	94.751	93.701	91.968
-16	95.947	96.509	97.925	96.362	97.559	98.169	96.826	97.217	95.825	97.583	97.241	95.825
-20	97.827	98.193	99.341	98.291	99.146	99.512	98.608	98.926	98.193	99.316	99.121	98.364
-24	98.950	99.146	99.780	99.048	99.756	99.878	99.365	99.561	99.390	99.731	99.756	99.316

Signal Level Above Median

2.4 Adaptive Decision Feedback Equalizer (ADFE)

The adaptive decision feedback equalizer (ADFE) modem (Figure 2-29) simulation has been designed to allow the users at DCEC to explore the characteristics of this demodulation technique under a variety of expected operating conditions. The operator may select the diversity configuration, adaptation bandwidth, time discriminator characteristics, and parameters of other critical filters by means of the remote hybrid terminal at DCEC. Other variations such as number of adaptive forward equalizer (AFE) taps, intertap spacing, and number of adaptive backward equalizer (ABE) taps may be selected by the user at DCEC.

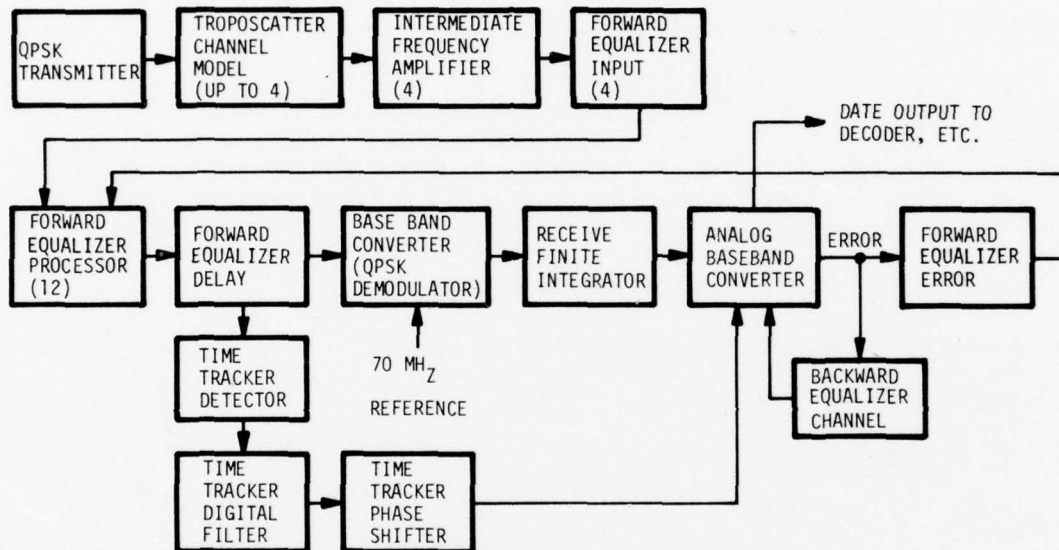

Figure 2-29. ADFE Simulation

Many subsystems in the ADFE modem are similar to corresponding subsystem in the other transmission systems simulated previously. The simulation of the common subsystems has been previously described and is mentioned only briefly here. In most cases, the modules discussed correspond to a single functional block within the modem. The modulator section, data encoders and decoders, and demultiplexers are all based on techniques developed earlier. The troposcatter channel model has been discussed in detail previously. Modules unique to the ADFE modem are discussed in the following paragraphs.

2.4.1 Intermediate Frequency Amplifier

In this simulation the intermediate frequency amplifier filters the incoming IF signal, regulates its amplitude to a scaled value of -10 dBm, and provides an AGC voltage to the common AGC buss. There are four such modules, one for each diversity. The filter is a bandpass filter with type,

The noise block interference was simulated by filtering a white noise source to approximate a Gaussian distribution. The bandpass filter's center frequency and bandwidth may be specified by the user. The signal-to-noise power ratio (SNR) is a parameter also specified by the remote user.

The calibration of the SNR was accomplished using the power spectral density (PSD) program described in paragraph 2.5.1 and an analog computer programmed RMS circuit. The received signal level (RSL) was measured in dB and the signal power (E_b) was calculated using the following equation:

$$E_b = \text{RSL} - 10 \log (\text{bit rate})$$

The noise power, N_o , was determined from

$$N_o = N_L - 10 \log (BW)$$

where

N_L is the measured noise power in dB for a known value of noise measured by the RMS circuit, for example, 8 volts rms.

BW is the bandwidth of the PSD measuring circuit.

The measured values for RSL and N_L were:

$$\text{RSL} = 3 \text{ dB}$$

$$N_L = -16 \text{ dB.}$$

Therefore,

$$\begin{aligned} E_b &= -3 \text{ dB} - 10 \log (1000) \\ &= -3 \text{ dB} - 30 \text{ dB} = -33 \text{ dB} \end{aligned}$$

$$\begin{aligned} N_o &= -16 \text{ dB} - 10 \log \left(\frac{1000}{2\pi} \right) \\ &= -16 \text{ dB} - 22 \text{ dB} = -38 \text{ dB} \end{aligned}$$

$$E_b/N_o = +5 \text{ dB.}$$

As a result, the noise power level was increased 5 dB so the E_b/N_o ratio is zero.

The delayed replica interference methodology was developed previously as a repeated jammer. The modulated signal may be delayed by an amount specified by the remote user and input to an identically simulated transmission system. The delay method developed uses a shift register to provide an incremental number of bit delays.

bandwidth, and order selected by the user through the remote hybrid terminal at DCEC. The AGC signal for each amplifier was produced by envelope detection of the filtered IF signal. The detected voltage determines the gain to be applied to the IF amplifier to regulate the IF signal level to a scaled value of -10 dBm. An AGC level selector logic signal was generated to identify which of the four amplifiers received the strongest signal and then select that AGC signal for all four amplifiers.

2.4.2 Forward Equalizer Input

The forward equalizer input supplies both a delayed and an undelayed version of the IF signal from each of the four diversities to the three forward equalizer processors in each diversity. The delay is produced by the same type of CCD analog delay lines used in the troposcatter channel model. An appropriate number of devices and clocking frequency were selected to provide the required delay.

2.4.3 Forward Equalizer Processor

The forward equalizer processor (FEP) module correlates the scaled 70 MHz error signal with the delayed version of the IF signal and uses the result to generate a weight by which to multiply the undelayed IF signal. The three resulting weighted undelayed IF signals are inputs to the adaptive forward equalizer (AFE) transversal filter.

The complex correlation is performed by splitting the delayed IF signal into two paths and then delaying one of the resulting signals by $\pi/2$. These signals are then mixed with the 70 MHz error signal and low-pass filtered to produce I and Q components of the complex correlation. The cutoff frequency of these filters, which can be specified remotely by the operator, controls the AFE loop bandwidth. The I component is then multiplied by the undelayed IF signal, and the Q component is multiplied by the same signal, which has been delayed an additional $\pi/2$. These two signals are finally summed to produce the weighted IF signals from that diversity. Four such signals are combined to produce the input to each tap of the AFE transversal filter.

Figure 2-30 is a block diagram of the simulated FEP. The required $\pi/2$ delays were simulated in two ways. Analog phase shifters have been built using standard filtering techniques, and the $\pi/2$ phase shifter is a standard configuration. Another approach used the CCD analog delay lines clocked at an appropriate rate. The mixers and multipliers are modeled by standard four quadrant analog multipliers.

2.4.4 Forward Equalizer Delay

The forward equalizer delay (FED) differentially delays and combines the weighted combined IF signal as indicated in Figure 2-31. The delay between the taps is 1/2 baud. The implementation of the delay line requires four CCD analog delay lines. Each CCD delays the IF signal approximately 5 cycles, allowing 100 samples per cycle.

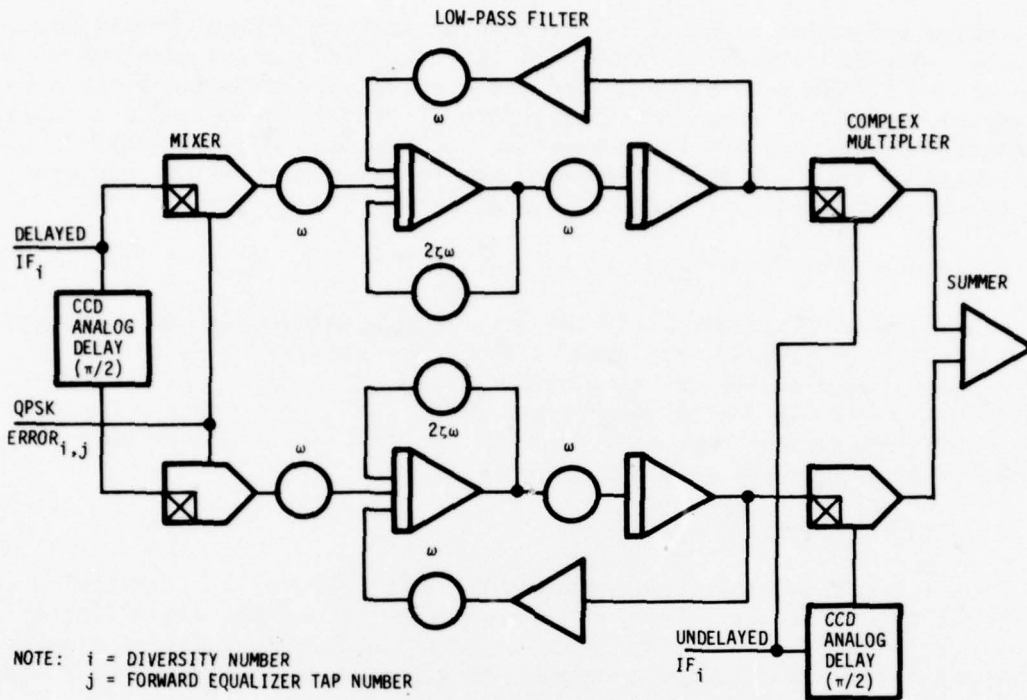

Figure 2-30. Forward Equalizer Processor

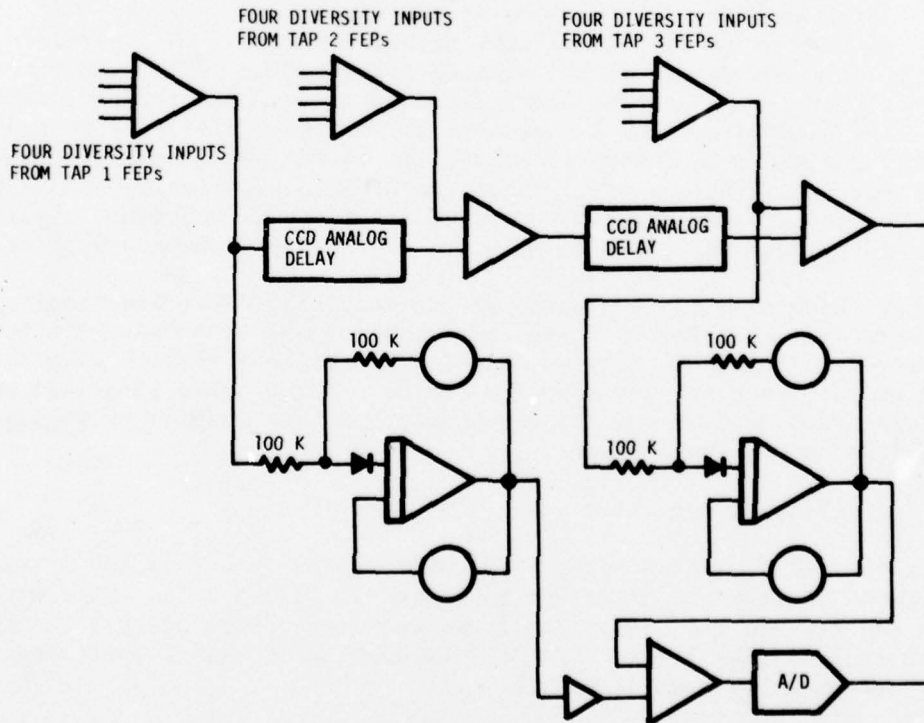

Figure 2-31. Forward Equalizer Delay and Time Tracker Detector

2.4.5 Megahertz Baseband Converter and Receive Finite Integrator

The megahertz baseband converter (MBC) demodulates the equalized IF signal into in-phase and quadrature baseband signals. The scaled 70 MHz reference signal is split with one of the resulting signals delayed by $\pi/2$. These quadrature reference signals are mixed with the equalized IF signal and low-pass filtered to produce the I and Q baseband signals. The receive finite integrator is contained in this low-pass filter. The cutoff and type of filter may be specified by the user.

2.4.6 Analog Baseband Combiner

The function of the analog baseband combiner (ABC) is to sample and hold the analog eye from the finite integrator, combine the resulting voltage with the output from the ABE to produce a compensated eye, and produce an error signal for use in the ABE and AFE. A shift register delay line delays the received I and Q data for use by the ABE.

The sample-and-hold operation is performed by a standard sample-and-hold amplifier in the analog computer. The D/A conversion required for the output of the ABE utilizes the hybrid computer interface. The data and error outputs were computed by comparing the compensated eye to fixed reference voltages and then performing the proper logic operations to form the output data and error signals. An ABD simulation diagram is shown in Figure 2-32.

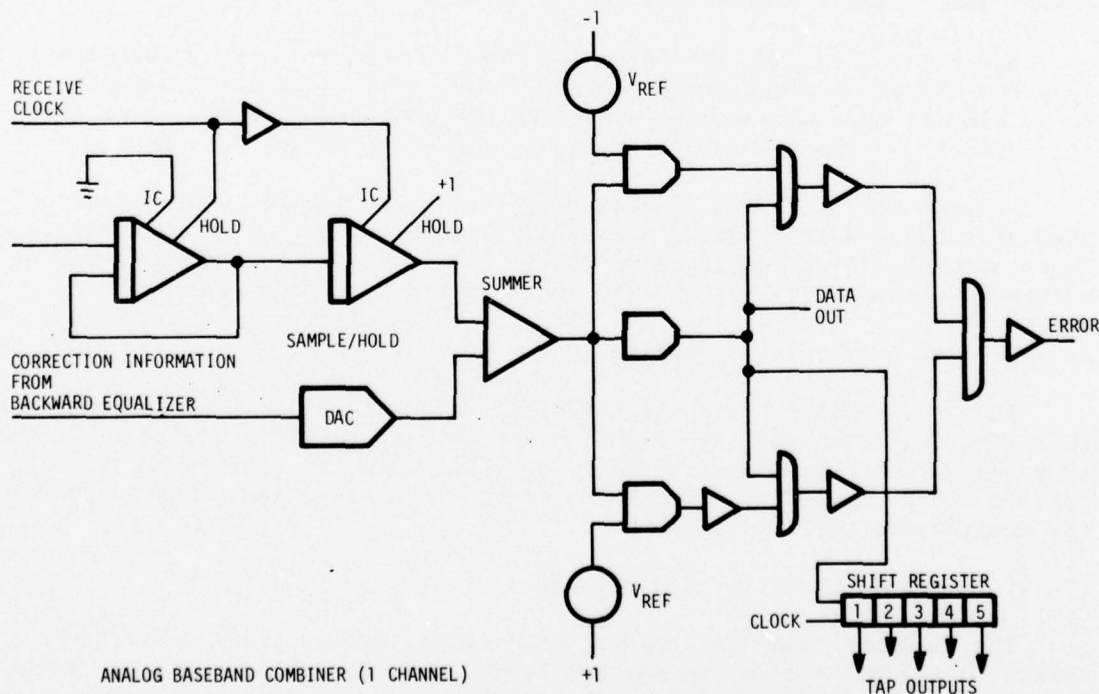

Figure 2-32. Analog Baseband Combiner (One Channel)

2.4.7 Forward Equalizer Error

The forward equalizer error (FEE) produces three scaled 70 MHz QPSK error signals for use by the FEP. The I and Q error signals from the ABC are each delayed by a three-stage shift register. The I and Q error signals from corresponding shift register taps were used to QPSK modulate the scaled 70 MHz reference signal. Provision has been made to turn off the first and third modulators to allow the modem to recover from baud slip.

The shift registers are implemented using the shift registers on the analog computer logic patch panel. The output signals from the shift registers control analog electronic switches (Figure 2-33) to produce the QPSK modulation. The scaled 70 MHz reference signal is obtained from the MBC.

2.4.8 Time Tracking Detector

The time tracking detector (TTD) develops a phase error signal from the difference between the detected outputs of the first and third AFE delay line taps. This error signal controls the phase of the receiver clock and ensures the sample-and-hold operation in the ABC occurs at the proper time. The TTD also converts the analog error to a digital signal suitable for the time tracker digital filter (TTF). A simulation diagram of the TTD appears with the forward equalizer delay in Figure 2-31.

2.4.9 Time Tracker Digital Filter

The function of the TTF is to low-pass filter the phase error signal from the TTD and produce the sine and cosine of the resulting signal. These signals are then used to shift the phase of the receiver clock into the correct position to ensure proper quantization of the compensated eye.

Implementation of the digital filter uses the digital computer associated with the hybrid computer system to perform the required computations. This approach offers considerable flexibility and uses the hybrid computer system interface, greatly simplifying the D/A and A/D conversions.

2.4.10 Time Tracker Phase Shifter

The time tracker phase shifter (TTS) (Figure 2-34) shifts the phase of the receiver clock using the sine and cosine outputs from the TTF. The sine is mixed with the raw receive clock, and the cosine is mixed with the raw receive clock delayed by $\pi/2$. These signals are added and filtered to form the compensated receive clock.

2.4.11 Backward Equalizer Channel Card

The backward equalizer channel card (BEC) removes predictable inter-symbol interference from the current baud. This is accomplished by correlation of the present error signal with past data. The resulting correlation is processed to generate a correction signal for the ABC.

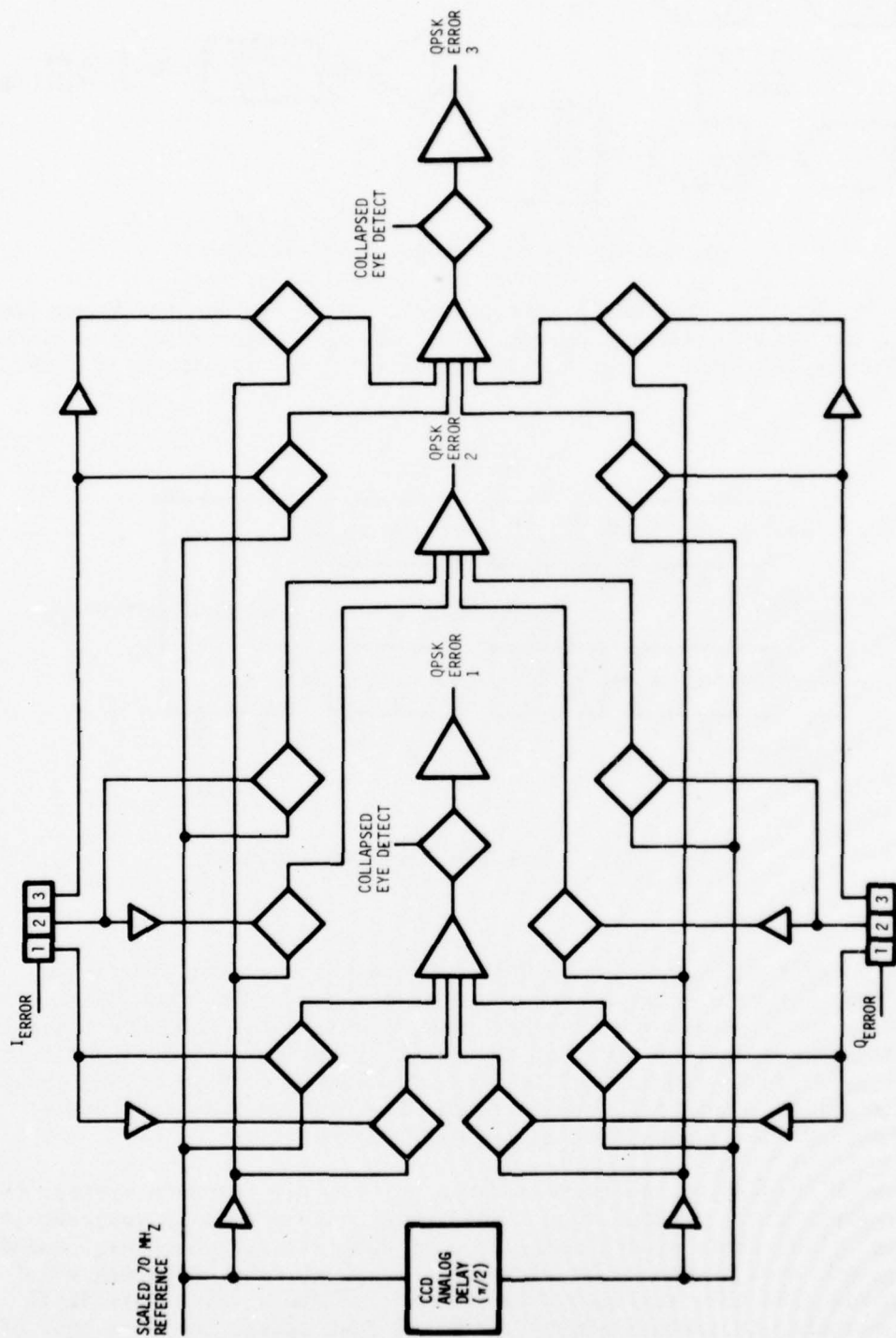

Figure 2-33. Forward Equalizer Error

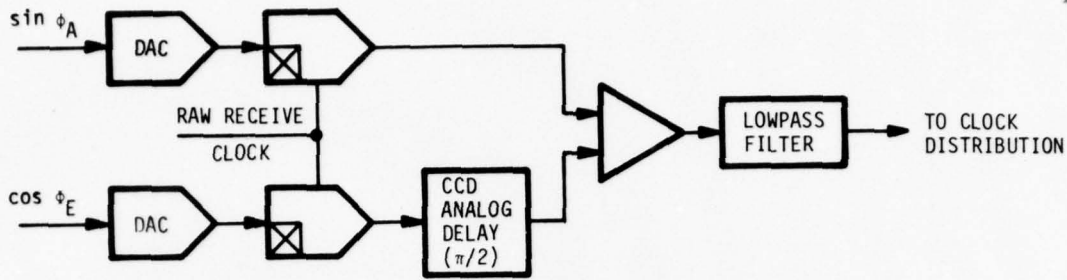

Figure 2-34. Time Tracker Phase Shifter

The functions of the BEC are performed by the parallel logic components contained within the analog computer. The parallel logic has the advantage of speed of computation. Figure 2-35 is a functional diagram of the BEC.

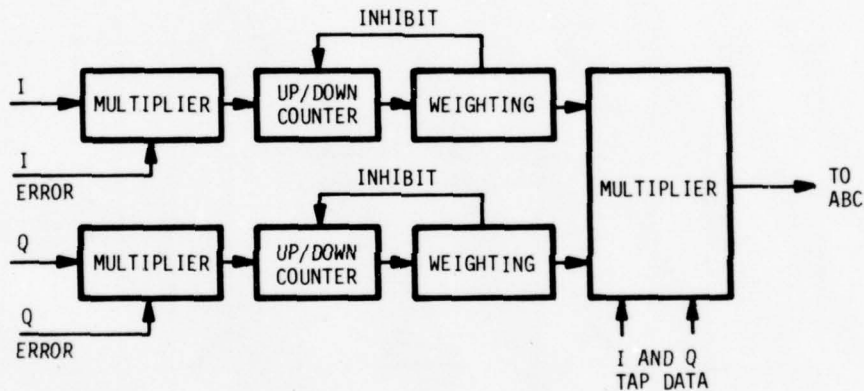

Figure 2-35. Backward Equalizer Channel

2.5 Support Software

The support software for the DRAMA transmission system simulation includes the set of digital programs and their subprograms that allow the remote user to interface with the Martin Marietta hybrid computer transmission simulation system by means of the remote terminal at DCEC. The support software permits the remote user to alter the system configuration, change system parameters, test and verify system elements, and make analytical evaluations of the transmission system performance.

Because the support software outgrew the digital computer system, the computer program was divided into a main program that remains resident in lower memory and other functionally grouped subprograms, which are loaded into a common area of memory by overlaying whatever subprogram was previously resident in that region. This approach allows a relatively small digital computer to perform digital programs that exceed the core size of the computer.

The main program when executed lists for the remote user the following broad options:

- 1 Power spectral density
- 2 Frequency response
- 3 Eye pattern
- 4 Bit error test
- 5 Choose modulation technique
- 6 Plot delay profile
- 7 Alter filter parameters
- 8 Return to nominal system
- 9 Alter system or parameters
- 10 Configuration.

The remote user is instructed to select one of these options, whereupon the computer overlays the selected option program and its subprograms into a region of memory. Examples of outputs from these programs are contained in Appendix G of this report.

2.5.1 Power Spectral Density

The power spectral density (PSD) program is a hybrid technique that incorporates an analog PSD circuit (Figure 2-36) that is controlled and sampled by the digital computer. Using a Fourier technique, the analog circuit generates the PSD of the signal being analyzed. The signal to be analyzed is multiplied by the sine and cosine outputs of a local oscillator. These signals are filtered by a low-pass filter to eliminate all but the constant terms A and B, the in-phase and out-of-phase components of the signal. These two resultants are squared, added, and low-pass filtered (averaged) to produce a term proportional to the average power of the signal at a frequency specified by the local oscillator. This signal is sampled by the digital computer, converted to decibels, and normalized to be plotted for the remote user.

The support software allows the remote user to select and obtain the spectral occupancy of a signal measured at 1) modulator output, 2) first transmitter filter, 3) transmitter nonlinearity, and 4) second transmitter filter, or 5) any other point in the system by manual intervention.

The digital program switches the selected output signal into the input of the analog PSD circuit.

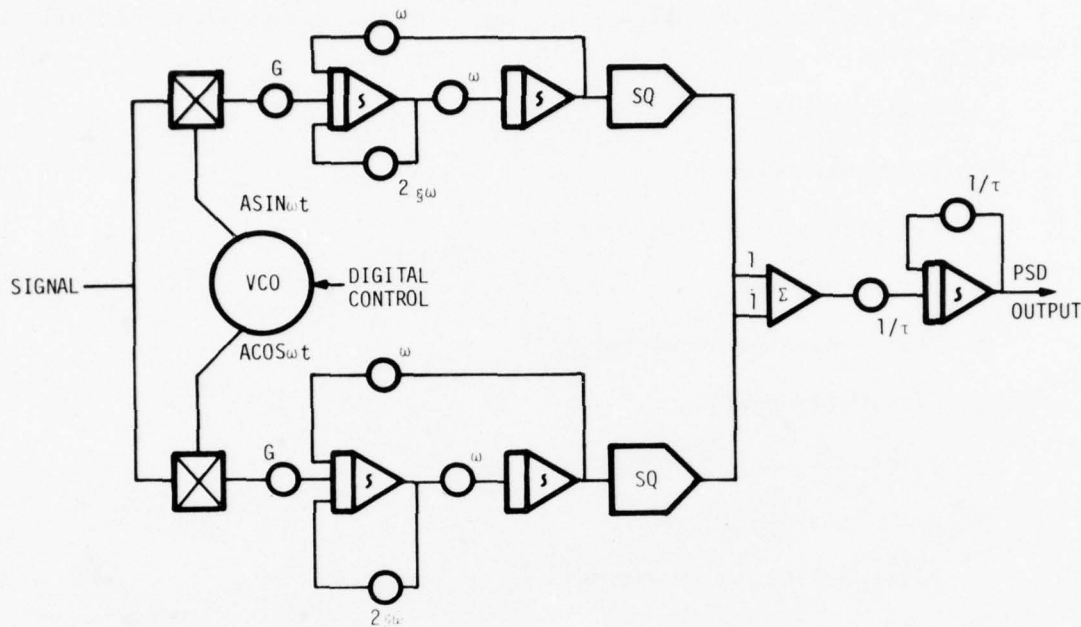

Figure 2-36. Power Spectral Density Analog Circuit

The remote user is queued to enter the number of lags, up to 2000. A lag is a term used to describe the process by which the power contained in a signal at a particular frequency is determined. Therefore, the number of lags is the number of samples of the power output by the PSD circuit excited at a number of frequencies.

The program asks the remote user to enter the low frequency and then determine the spectrum of frequencies over which the spectral occupancy will be measured. The frequency spectrum is divided by the number of lags to determine the incremental frequency. The power is sampled for each incremental frequency, converted to decibels, normalized, and plotted out as a continuous plot of power in decibels over the range of frequencies.

In addition to the spectral occupancy plot, the program displays the upper and lower frequency bounds of the band of frequencies that contain 99 percent of the power. This 99 percent spectral occupancy is determined for the frequency extremes defined previously by the remote user. The frequency at which the center of power exists is also displayed.

2.5.2 Bit Error Test

The bit error test program consists of a program that calculates the bit error rate for various system configurations that may be selected by the user. The bit error rate for a configuration is simply the accumulation of the number of errors occurring during a specified period of time divided by

the number of interrupts generated by the bit rate clock during the same period. The total number of bits transmitted, total number of errors, and the bit error rate are printed out for each test.

System configuration elements that may be changed in this program are channel configuration, quality monitor selection, and signal-to-noise ratio. Channel configuration options are 1) Rayleigh, 2) troposcatter, 3) out, and 4) LOS.

The out option consists of switching the analog simulation so that the channel model simulation is bypassed and the AGC gain is forced to zero.

The troposcatter option consists of subprograms to calculate the delay power profile, a digital filter module, and a bit error test. The delay power profile subprogram calculates the delay power and amplitude profiles for parameters selected by the user. The parameters are:

- 1 Path length in miles
- 2 Smooth earth option
- 3 Horizontal angles in degrees
- 4 Effective earth
- 5 Antenna beamwidth in degrees
- 6 Number of points at 71 nanosecond spacing.

If the smooth earth option is selected, the horizontal angles are not required for the calculation. While the program has the capability of calculating 50 points on the delay profile, only 12 will be used by the digital filter program because there are only 12 delay line taps. The delay, power, and amplitude values are output as a table, and an optional plot of the power profile relative to the delay is displayed for the user.

The digital filter module generates 48 uncorrelated random noise sequences, filters them, and transfers them to the analog computer. These signals are generated by sampling a wideband Gaussian noise source, filtered by a second order digital Butterworth filter. The filter has a nominal cutoff frequency equal to the fade rate. The fade rate is selected by the user and has a fade rate of 1 Hz at the maximum sample frequency of 40 samples per second. Slower fade rates are accomplished by using the same filter but varying the sample frequency. These fading signals are output to the digitally controlled attenuators on the analog computer, where they are multiplied by the outputs of the delay taps. These products are summed appropriately to provide the LOS channel model signals, which are the input signals to the two receiver channels.

The bit error test portion of the program is synchronized with the digital filter program. Since the digital filter values are zero initially, a number of errors are generated until realistic values are obtained. The bit error test program ignores these errors and does not begin its accumulation during this period.

The Rayleigh fading channel option is similar to the troposcatter channel mechanization. The first term of the delay amplitude profile attenuation coefficients is 1 and the other 11 are 0. On the analog computer, the terms multiplied by the first delay line tap and its quadrature are the only terms that form the fading channel inputs to the four receiver channels.

The line-of-sight channel model is similar to the troposcatter channel model. The delay power profile subprogram is replaced, however, with a subprogram that allows the user to enter manually the tap gains for each tap and to select the tap delay spacing. The tap gain profile is loaded by the remote user for each of the 12 taps. A delay spacing may be selected from 0.25 to 2.0 bits in 0.1 bit increments.

The Rayleigh, troposcatter, and LOS channel models automatically switch the AGC into the system configuration.

Martin Marietta has designed the hybrid methodology necessary to permit DCEC remote hybrid terminal users to specify, generate, and display error distributions to assist in the analysis of the various troposcatter and line-of-sight transmission system simulations. The technique requires the generation of a digital magnetic tape, which records as a histogram the sampled errors for the two receiver channels and the diversity switch. This tape may then be used as an input to another digital program that performs the analysis or stores it for later reference.

The computer program is designed so that the user specifies, in response to the computer program questions, the burst interval and the error density criteria. The burst interval defines the length of time that the distribution analysis is performed, and the error density specifies the error density criteria to mark the beginning of the error burst.

The output of the program includes the normalized mean distribution of the burst and the error free gap mean distribution, which is the inversion of the error burst distribution. Other tabular information such as the number of blocks, bursts, error free intervals, and the number of intervals may also be graphically displayed. Finally, the user may select as an option a plot of the burst distribution.

2.5.3 Filter Alteration

The filter alteration program is a hybrid technique that provides the user with the capability of changing the two transmitter RF bandpass filters and the four receiver IF bandpass filters. The user may select a Butterworth or Chebychev characteristic and the order of the filter, and specify its center frequency and bandwidth. If the Chebychev filter characteristic is selected, the user supplies the computer with the ripple factor in decibels. These parameters are entered into the system as responses to questions asked by the computer.

The approach taken computes the low-pass filter prototype and converts it to a bandpass filter. The roots of Butterworth low-pass filter are given by

$$\sigma_K = \sin\left(\frac{2K-1}{N}\right) \cdot \frac{\pi}{2}$$

the real part, and

$$\omega_K = \cos\left(\frac{2K-1}{N}\right) \cdot \frac{\pi}{2}$$

the imaginary part, where n is the order of the low-pass prototype filter and

$$K = 0, 1, 2, \dots, 2n.$$

For this simulation, only the roots in the upper quadrant of the left plane are used. If the Chebychev characteristic option is selected, the roots derived for the Butterworth low-pass filter prototype are altered by applying an algorithm based on the ripple factor, S .

$$\epsilon_p = (10^S - 1)^{-1/2}$$

$$a = [(\epsilon_p^2 + 1)^{1/2} + \epsilon_p] / n$$

$$\tanh(a) = \frac{a - 1/a}{a + 1/a}$$

$$\cosh(a) = 0.5(a + 1/a).$$

The cosha term is the normalized 3 dB cutoff frequency for the Chebychev characteristic filter. The tanha term is multiplied by the real term. Thus the Chebychev roots are

$$r_K = \cosh(a) (-\tanh(a) \sigma_K + j\omega_K).$$

The K roots of the low-pass prototype are converted to the $2K$ roots of the bandpass filter by using the quadratic equation for complex roots.

The coefficients for the transfer function of the bandpass filter are determined from the derived roots. These coefficients scaled properly are the values to which the digitally controlled attenuators are set in the filter mechanizaion of Figure 2-8. However, the frequency response characteristic of the filter will not compare favorably with its theoretical response. This is due to a number of elements but primarily because the analog computer system was designed to meet specification requirements at frequencies less than the 2.681 kHz scaled frequency of the filter. Therefore, a program was written that would tweak the filters until they were acceptable.

The bandpass filters consist of up to three stagger-tuned stages to approximate the total filter characteristic. Therefore, each individual stage is adjusted by alternately adjusting the center frequency potentiometers until the phase error is less than one degree, then adjusting the feedback bandwidth potentiometer until the gain is within 1 percent of its theoretical value. Each section is alternately adjusted relative to phase and gain six times before going to the next section. When each section is adjusted, the output of the total filter is adjusted to unity at the center frequency by varying the forward gain of the output of the filter.

The user has the option of running a frequency response test on the filter to verify visually that the filter is set properly. The user responds to questions from the computer to enter the lowest and highest frequencies of interest and the number of points to be tested. The program works by driving the input of the filter with the output of an amplitude-stabilized variable frequency controlled oscillator. The resulting filter output is peak detected, sampled, and stored. This process is repeated for each frequency point until the entire characteristic is stored. The ratio of the filter output to its input is determined in decibels, together with corresponding phase characteristic. The gain and phase characteristics for each frequency point are then printed in tabular form for the user. A Bode plot of the gain characteristic relative to changes in frequency is also displayed graphically.

In addition to the IF and RF bandpass filters, a frequency response test can be made of the baseband filters. Since for QPR the partial response filter frequency response is defined for the combination of the transmitter and receiver filters, the frequency test is made with an oscillator driving the input of the transmitter filter and the response measured at the output of the receiver filter. To do this, the output of the transmitter filter is switched to the input of the receiver filter. For QPSK, the Butterworth low-pass filter in the receiver is tested and plotted.

2.5.4 System Configuration

The support software also lists selected elements of the system configuration. This system configuration list informs the user of the present system configuration and allows the user to change individual parameters of the system. These parameters are:

- 1 Run number
- 2 Transmitter filters
- 3 Nonlinear device
- 4 Channel configuration
- 5 AGC

- 6 Receiver IF filters
- 7 Eb/No ratio
- 8 Drive power
- 9 Run time
- 10 Scrambler.

In addition to altering the receiver IF filters, paragraph 2.5.2 discusses altering the transmitter filters that are both before and after the simulated nonlinear power amplifier. However, the user has the flexibility to select or delete from the signal path either filter as well as the nonlinear power amplifier circuit.

The channel configuration is delineated in paragraph 2.5.2, Bit Error Test. However, the channel configuration - Rayleigh, troposcatter, LOS, or nonfading - may be included in the system without running a bit error test. The presence or absence of the AGC may be selected independently of the channel configuration.

The receiver channels may be subjected to interference and an analog white noise source bandpass-filtered to approximate a Gaussian distribution. The user has the flexibility to select a signal-to-noise ratio as an input parameter. The Eb/No ratio is calibrated to specify the ratio of energy per bit versus the noise density of a Gaussian noise source.

The drive power gain is selected by the user to specify the power of the transmitted signal. The drive power is specified in decibels where -20 dB is maximum. The noise input is also reduced proportionately to the drive power gain to maintain the integrity of the signal-to-noise ratio.

3.0 REMOTE TERMINAL SUPPORT

During this final 9-month reporting period Martin Marietta has supported 125 hours of hybrid computer remote terminal time for system control and transmission systems personnel at the Defense Communications Engineering Center, Reston, Virginia. A total of 150 hours has been supported over the period of this contract.

In addition to the hybrid terminal time, software has been developed to allow an interactive interface with complex system control and digital transmission systems simulations. Using a conversational query and answer response, dynamic simulations can be configured from the remote terminal, and both analog and digital data and displays of resulting responses can be obtained from the Tektronix terminal and Brush chart recorder.

PRECEDING PAGE NOT FILMED
BLANK

REFERENCES

- 1 Martin Marietta Corporation OR 15,119, Hybrid Computer Simulation Studies for System Control and Transmission, June 1978.
- 2 Martin Marietta Corporation OR 14,224, Hybrid Computer Simulation Study of Control Techniques for Switched Networks and Digital Transmission Techniques to Enhance System Performance.

PRECEDING PAGE NOT FILMED
BLANK

APPENDIX A

OVERSEAS AUTOVON NETWORK DATA

The nominal Overseas AUTOVON sizing, connectivity, routing table, and traffic data utilized with the interactive network simulator are presented in this appendix.

1.0 Network Connectivity and Sizing

The Overseas AUTOVON network diagram (Figure A-1) contains connectivity and sizing data for both the European and Pacific theaters. Distinction between terrestrial and satellite trunks is indicated. Also indicated in the figure are nodes to which calls may be spilled forward (from certain originating nodes). The Pacific network configuration is derived from Figure 2 of DCEC TN 4-75, less the Taipei switch and with one additional trunk between the Fort Buckner and Fuchu switches. The European network configuration is that of the Donnersberg gateway update, 4 November 1978. RSJ capacities utilized in the model are listed below for each of the European switches.

HIN	20	MAM	20	HUM	15
FEL	30	SCH	20	CTO	15
LKF	20	DON	30	MTP	15
MTV	15				

2.0 Network Routing Tables

The nominal routing tables for the European and Pacific theaters are presented in Tables A-1 and A-2. The European routing table consists of the 4 November 1978 AUTOVON engineered routes for the Donnersberg gateway update. The Pacific routing table is from Table II of DCEC TN 4-75 modified to accommodate the additional link of the DSCS configuration and the deletion of the Taipei switch.

3.0 Traffic Data

Tables A-3 through A-9 contain the nominal traffic data for the European and Pacific theaters. The European traffic data is taken from the DCA Headquarters Code 520 letter entitled "Support for European AUTOVON Reconfiguration," dated 14 November 1977, and is based on busy hour traffic averaged over the period from September 1976 to February 1977. The European traffic data distribution is taken from the DCA Code 530 letter entitled "European AUTOVON Traffic Reconfiguration Study," dated 24 February 1978. The Pacific data is taken from Table I of DCEC TN 4-75 (without the Taipei switch).

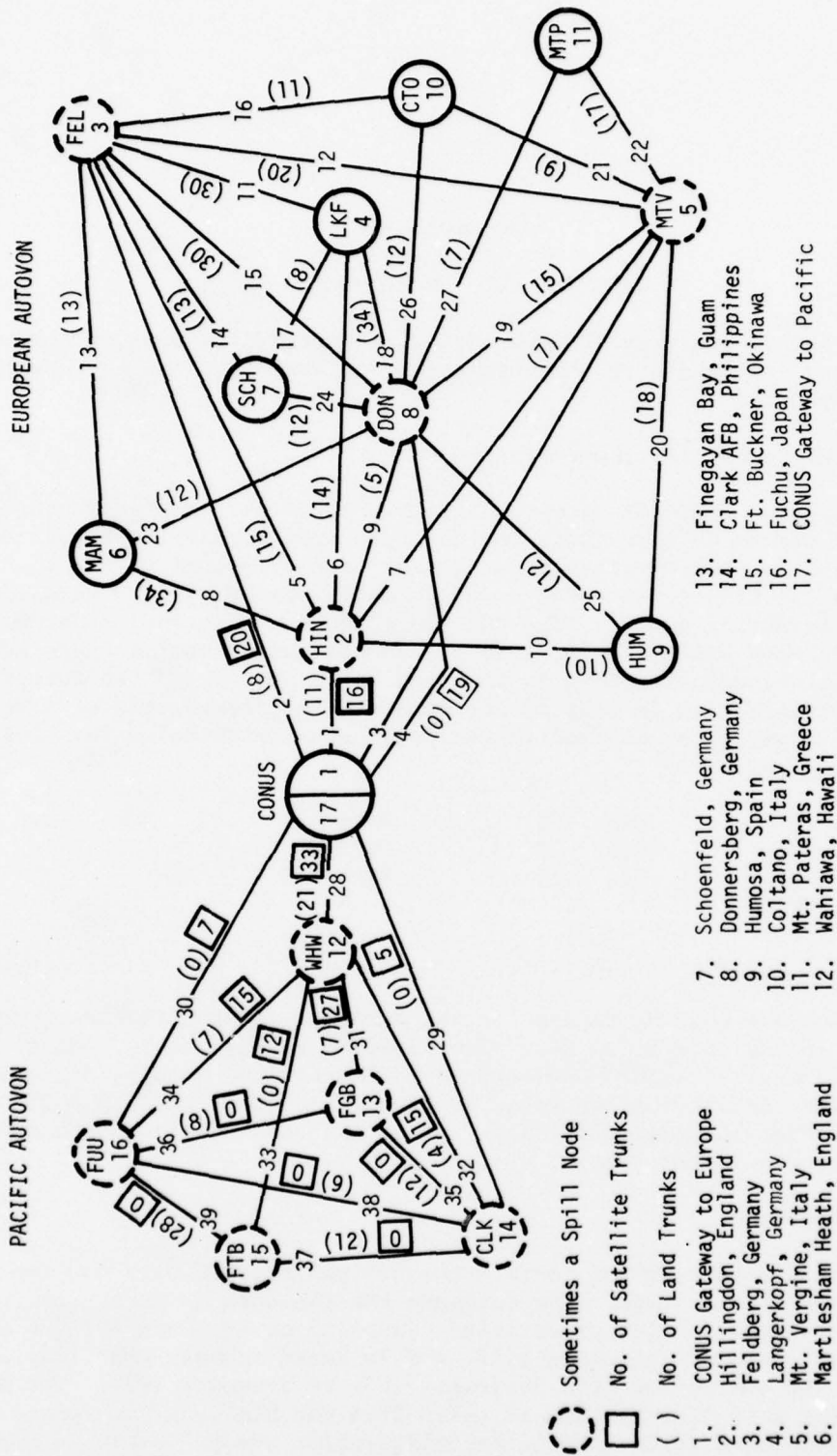

- Sometimes a Spill Node
- No. of Satellite Trunks
- () No. of Land Trunks
- 1. CONUS Gateway to Europe
- 2. Hillingdon, England
- 3. Feldberg, Germany
- 4. Langerkopf, Germany
- 5. Mt. Vergine, Italy
- 6. Martlesham Heath, England
- 7. Schoenfeld, Germany
- 8. Donnersberg, Germany
- 9. Humosa, Spain
- 10. Coltano, Italy
- 11. Mt. Pateras, Greece
- 12. Wahiawa, Hawaii
- 13. Finegayan Bay, Guam
- 14. Clark AFB, Philippines
- 15. Ft. Buckner, Okinawa
- 16. Fuchu, Japan
- 17. CONUS Gateway to Pacific

Figure A-1. Overseas AUTOVON Network Model

TABLE A-1. EUROPEAN AUTOVON ROUTING TABLE

		NODE TO NODE ROUTING TABLE										
NS	PTH	ND1S	ND2S	ND3S	ND4S	ND5S	ND6S	ND7S	ND8S	ND9S	ND10S	ND11S
1	1	0:0	2:0	3:0	3:0	5:0	2:0	3:0	8:0	2:0	5:0	5:0
	2	0:0	3:0	2:0	2:0	3:0	3:0	8:0	3:0	8:0	3:0	3:0
	3	0:0	5:0	8:0	8:0	2:0	8:0	2:0	2:0	5:0	8:0	2:0
	4	0:0	0:0	0:0	0:0	0:0	0:0	0:0	0:0	0:0	0:0	0:0
2	1	1:1	0:0	3:1	4:1	5:1	6:1	4:1	8:1	9:1	5:1	5:1
	2	3:1	0:0	6:1	3:1	3:1	0:0	3:1	6:1	4:1	3:1	6:1
	3	5:1	0:0	0:0	0:0	0:0	0:0	0:0	3:1	3:1	0:0	0:0
	4	0:0	0:0	0:0	0:0	0:0	0:0	0:0	0:0	0:0	0:0	0:0
3	1	1:0	2:1	0:0	4:1	5:1	6:1	7:1	8:1	5:1	10:1	5:1
	2	2:1	6:1	0:0	8:1	8:1	8:1	4:1	8:1	4:1	8:1	8:1
	3	8:1	0:0	0:0	0:0	0:0	0:0	0:0	0:0	2:1	0:0	0:0
	4	0:0	0:0	0:0	0:0	0:0	0:0	0:0	0:0	0:0	0:0	0:0
4	1	3:1	2:1	3:1	0:0	8:1	8:1	7:1	8:1	8:1	8:1	8:1
	2	2:1	3:1	8:1	0:0	3:1	2:1	8:1	7:1	3:1	3:1	3:1
	3	8:1	0:0	0:0	0:0	0:0	3:1	3:1	3:1	2:1	0:0	0:0
	4	0:0	0:0	0:0	0:0	0:0	0:0	0:0	0:0	0:0	0:0	0:0
5	1	1:1	2:1	3:1	8:1	0:0	8:1	8:1	8:1	9:1	10:1	11:1
	2	3:1	3:1	8:1	3:1	0:0	2:1	3:1	10:1	2:1	3:1	0:0
	3	2:1	0:0	0:0	0:0	0:0	3:1	0:0	3:1	8:1	0:0	0:0
	4	0:0	0:0	0:0	0:0	0:0	0:0	0:0	0:0	0:0	0:0	0:0
6	1	2:1	2:1	3:1	8:1	8:1	0:0	8:1	8:1	2:1	8:1	8:1
	2	3:1	0:0	8:1	2:1	2:1	0:0	3:1	3:1	8:1	3:1	2:1
	3	8:1	0:0	0:0	3:1	3:1	0:0	0:0	0:0	3:1	0:0	3:1
	4	0:0	0:0	0:0	0:0	0:0	0:0	0:0	0:0	0:0	0:0	0:0
7	1	3:1	4:1	3:1	4:1	8:0	8:0	0:0	8:1	8:0	8:0	8:0
	2	8:0	3:1	8:0	8:0	3:1	3:1	0:0	4:1	3:1	3:1	3:1
	3	0:0	0:0	0:0	5:1	0:0	0:0	0:0	3:1	0:0	0:0	0:0
	4	0:0	0:0	0:0	0:0	0:0	0:0	0:0	0:0	0:0	0:0	0:0
8	1	1:0	2:1	3:1	4:1	5:1	6:1	7:1	0:0	9:1	10:1	11:1
	2	3:1	6:1	4:1	3:1	10:1	2:1	4:1	0:0	5:1	3:1	10:1
	3	2:1	3:1	0:0	0:0	3:1	3:1	3:1	0:0	3:1	0:0	5:1
	4	0:0	0:0	0:0	0:0	0:0	0:0	0:0	0:0	0:0	0:0	0:0
9	1	2:1	2:1	8:1	8:1	5:1	2:1	8:1	8:1	0:0	5:0	5:0
	2	5:0	5:0	5:0	5:0	2:1	5:0	5:0	5:0	0:0	8:1	8:1
	3	0:0	0:0	2:1	2:1	0:0	0:0	2:1	2:1	0:0	2:1	0:0
	4	0:0	0:0	0:0	0:0	0:0	0:0	0:0	0:0	0:0	0:0	0:0
10	1	5:1	5:1	3:1	8:1	5:1	8:1	8:1	8:1	5:1	0:0	5:1
	2	3:1	3:1	8:1	3:1	3:1	3:1	3:1	3:1	8:1	0:0	8:1
	3	8:0	0:0	0:0	0:0	0:0	0:0	0:0	0:0	0:0	0:0	0:0
	4	0:0	0:0	0:0	0:0	0:0	0:0	0:0	0:0	0:0	0:0	0:0
11	1	5:0	5:0	8:1	8:1	5:1	5:0	8:1	8:1	5:0	5:0	0:0
	2	0:0	0:0	5:0	5:0	0:0	0:0	5:0	5:0	0:0	0:0	0:0
	3	0:0	0:0	0:0	0:0	0:0	0:0	0:0	0:0	0:0	0:0	0:0
	4	0:0	0:0	0:0	0:0	0:0	0:0	0:0	0:0	0:0	0:0	0:0

TABLE A-2. PACIFIC AUTOVON ROUTING TABLE

NS	PTH	ND12S	ND13S	ND14S	ND15S	ND16S	ND17S
12	1	0:0	13:1	14:1	15:1	16:1	17:1
	2	0:0	0:0	15:0	16:0	15:0	0:0
	3	0:0	0:0	13:0	14:0	13:0	0:0
	4	0:0	0:0	0:0	0:0	0:0	0:0
13	1	12:1	0:0	14:1	14:2	16:1	12:0
	2	0:0	0:0	0:0	16:1	0:0	0:0
	3	0:0	0:0	0:0	0:0	0:0	0:0
	4	0:0	0:0	0:0	0:0	0:0	0:0
14	1	12:1	13:1	0:0	15:1	16:1	17:1
	2	13:1	0:0	0:0	0:0	15:1	12:0
	3	0:0	0:0	0:0	0:0	0:0	13:1
	4	0:0	0:0	0:0	0:0	0:0	0:0
15	1	12:1	16:1	14:1	0:0	16:1	12:0
	2	16:1	14:0	0:0	0:0	0:0	16:2
	3	14:0	0:0	0:0	0:0	0:0	14:0
	4	0:0	0:0	0:0	0:0	0:0	0:0
16	1	12:1	13:1	14:1	15:1	0:0	17:1
	2	13:1	0:0	15:2	0:0	0:0	12:0
	3	0:0	0:0	0:0	0:0	0:0	13:1
	4	0:0	0:0	0:0	0:0	0:0	0:0
17	1	12:1	12:0	14:1	12:0	16:1	0:0
	2	0:0	0:0	12:0	16:0	12:0	0:0
	3	0:0	0:0	0:0	14:0	0:0	0:0
	4	0:0	0:0	0:0	0:0	0:0	0:0

TABLE A-3. EUROPEAN AUTOVON TRAFFIC TOTALS FOR ALL PRIORITIES (ERLANGS)

TO FROM	CON	HIN	MAM	SCH	FEL	DON	LKF	HUM	CTO	MTV	MTP
CON	-	6.35	2.65	1.10	6.35	5.85	6.85	3.45	0.55	3.05	2.10
HIN	12.00	-	3.40	0.20	0.10	2.70	0.90	0.40	0.05	0.05	0.40
MAM	5.40	0.80	-	0.20	0.40	5.60	2.00	1.30	0.50	0.05	0.30
SCH	2.10	0.10	0.40	-	1.30	2.80	1.90	0.70	0.40	0.0	0.0
FEL	12.00	0.05	0.50	3.50	-	8.70	5.70	0.30	1.80	0.60	1.10
DON	15.70	0.50	1.40	1.10	5.60	-	5.10	0.80	1.20	1.30	0.20
LKF	15.00	0.50	2.00	2.00	7.90	4.50	-	1.90	1.00	0.70	0.70
HUM	6.20	0.50	1.10	1.20	1.00	2.10	1.60	-	1.00	1.10	0.50
CTO	1.50	0.05	0.05	0.40	4.10	3.20	1.30	0.90	-	0.60	0.50
MTV	6.10	0.05	0.10	0.20	1.00	2.00	1.30	0.60	1.20	-	0.40
MTP	5.40	0.50	0.10	0.10	2.60	2.00	1.50	0.90	0.05	0.50	-

TABLE A-4. EUROPEAN AUTOVON TRAFFIC OFFERED FOR PRIORITY 0: FLASH OVERRIDE (ERLANGS)

TO FROM	CON	HIN	MAM	SCH	FEL	DON	LKF	HUM	CTO	MTV	MTP
CON	-	0.0012	0.0005	0.0002	0.0012	0.0011	0.0013	0.0006	0.0001	0.0006	0.0004
HIN	0.0024	-	0.0001	0.00001	0.000005	0.00001	0.00004	0.00002	0.000002	0.000002	0.00002
MAN	0.001	0.00004	-	0.00001	0.00002	0.0002	0.0001	0.00006	0.00002	0.000002	0.00001
SCH	0.0004	0.000005	0.00002	-	0.00006	0.0001	0.00009	0.00003	0.00002	-	-
FEL	0.0024	0.000002	0.00002	0.0001	-	0.0004	0.0002	0.00001	0.00009	0.00003	0.00005
DON	0.0031	0.00002	0.00007	0.00005	0.0002	-	0.0002	0.00004	0.00006	0.00006	0.00001
LKF	0.003	0.00002	0.0001	0.0001	0.0003	0.0002	-	0.00009	0.00005	0.00003	0.00003
HUM	0.0012	0.00002	0.00005	0.00006	0.00005	0.0001	0.00008	-	0.00005	0.00005	0.00002
CTO	0.0003	0.000002	0.000002	0.00002	0.0002	0.0001	0.00006	0.00004	-	0.00003	0.00002
MTV	0.0012	0.000002	0.000005	0.00001	0.00005	0.0001	0.00006	0.00003	0.00006	-	0.00002
MTP	0.001	0.00002	0.000005	0.000005	0.0001	0.0001	0.00007	0.00004	0.000002	0.00002	-

NOTE:

Priority 0 traffic is assumed to be 5 percent of the total priority 0 and priority 1 traffic.

TABLE A-5. EUROPEAN AUTOVON TRAFFIC OFFERED FOR PRIORITY 1: FLASH (ERLANGS)

TO FROM	CON	HIN	MAM	SCH	FEL	DON	LKF	HUM	CTO	MTV	MTP
CON	-	0.0241	0.010	0.0041	0.0241	0.022	0.026	0.0131	0.002	0.0115	0.0079
HIN	0.0456	-	0.0032	0.0001	0.00009	0.0025	0.0008	0.0003	0.00004	0.00004	0.0003
MAM	0.020	0.0007	-	0.0001	0.0003	0.0053	0.0019	0.0012	0.0004	0.00004	0.0002
SCH	0.0079	0.00009	0.0003	-	0.0012	0.0026	0.0018	0.0006	0.0003	0.0000	0.0000
FEL	0.0456	0.0035	0.0004	0.0033	-	0.0082	0.0054	0.0002	0.0017	0.0005	0.0010
DON	0.0596	0.0004	0.0013	0.0010	0.0053	-	0.0048	0.0007	0.0011	0.0012	0.0001
LKF	0.057	0.0004	0.0019	0.0019	0.0075	0.0042	-	0.0018	0.0009	0.0006	0.0006
HUM	0.0235	0.0004	0.001	0.0011	0.0009	0.0019	0.0015	-	0.0009	0.001	0.0004
CTO	0.0057	0.00004	0.00004	0.0003	0.0038	0.003	0.0012	0.0008	-	0.0005	0.0004
MTV	0.0231	0.00004	0.00009	0.0001	0.0009	0.0019	0.0012	0.0005	0.0011	-	0.0003
MTP	0.0205	0.0004	0.00009	0.00009	0.0024	0.0019	0.0014	0.0008	0.00004	0.0004	-

TABLE A-6. EUROPEAN AUTOVON TRAFFIC OFFERED FOR PRIORITY 2: IMMEDIATE (ERLANGS)

TO FROM	CON	HIN	MAM	SCH	FEL	DON	LKF	HUM	CTO	MTV	MTP
CON	-	3.33	1.39	0.577	3.33	3.07	3.59	1.81	0.288	1.6	1.10
HIN	6.30	-	0.238	0.014	0.007	0.189	0.063	0.028	0.0035	0.0035	0.028
MAM	2.83	0.056	-	0.014	0.028	0.392	0.140	0.091	0.035	0.0035	0.021
SCH	1.10	0.007	0.028	-	0.091	0.196	0.133	0.049	0.028	0.0000	0.000
FEL	6.3	0.0035	0.035	0.245	-	0.609	0.399	0.021	0.126	0.042	0.077
DON	8.24	0.035	0.098	0.077	0.392	-	0.357	0.056	0.084	0.091	0.014
LKF	7.87	0.035	0.140	0.140	0.553	0.315	-	0.133	0.070	0.049	0.049
HUM	3.25	0.035	0.077	0.084	0.07	0.147	0.112	-	0.070	0.077	0.035
CTO	0.787	0.0035	0.0035	0.028	0.287	0.224	0.091	0.063	-	0.042	0.035
MTV	3.2	0.0035	0.007	0.014	0.070	0.140	0.091	0.042	0.084	-	0.028
MTP	2.83	0.035	0.007	0.007	0.182	0.140	0.105	0.063	0.0035	0.035	-

TABLE A-7. EUROPEAN AUTOVON TRAFFIC OFFERED FOR PRIORITY 3: PRIORITY (ERLANGS)

TO FROM	CON	HIN	MAM	SCH	FEL	DON	LKF	HUM	CTO	MTV	MTP
CON	-	1.84	0.768	0.319	1.84	1.69	1.98	1.0	0.159	0.884	0.609
HIN	3.48	-	0.6188	0.0364	0.0182	0.4914	0.1638	0.0728	0.0091	0.0091	0.072
MAM	1.56	0.1456	-	0.0364	0.0728	1.019	0.3640	0.2366	0.091	0.0091	0.0546
SCH	0.609	0.0182	0.0728	-	0.2366	0.5096	0.3458	0.1274	0.0728	-	-
FEL	3.48	0.0091	0.091	0.637	-	1.58	1.03	0.0546	0.3276	0.1092	0.2002
DON	4.55	0.091	0.2548	0.2002	1.01	-	0.9282	0.1456	0.2184	0.2366	0.0364
LKF	4.35	0.091	0.3640	0.3640	1.43	0.3150	-	0.3458	0.1820	0.1274	0.1274
HUM	1.79	0.0910	0.2002	0.2184	0.1820	0.3822	0.2912	-	0.182	0.2002	0.091
CTO	0.435	0.0091	0.0091	0.0728	0.7462	0.5824	0.2366	0.1638	-	0.1092	0.091
MTV	1.76	0.0091	0.0182	0.0364	0.1820	0.3640	0.2366	0.1092	0.2184	-	0.0728
MTP	1.56	0.091	0.0182	0.0182	0.4732	0.364	0.273	0.1638	0.0091	0.091	-

TABLE A-8. EUROPEAN AUTOVON TRAFFIC OFFERED FOR PRIORITY 4: ROUTINE (ERLANGS)

TO FROM	CON	HIN	MAM	SCH	FEL	DON	LKF	HUM	CTO	MTV	MTP
CON	-	1.14	0.4796	0.1991	1.14	1.05	1.23	0.6244	0.0995	0.552	0.3801
HIN	2.17	-	2.53	0.1494	0.0747	2.01	0.6723	0.2988	0.0373	0.0373	0.2988
MAM	0.9774	0.5976	-	0.1494	0.2988	4.18	1.49	0.9711	0.3735	0.0373	0.2241
SCH	0.3801	0.0747	0.2988	-	0.9711	2.09	1.41	0.5229	0.2988	-	-
FEL	2.17	0.0373	0.3735	2.61	-	6.49	4.25	0.2241	1.34	0.448	0.8217
DON	2.84	0.3735	1.04	0.8217	4.18	-	3.809	0.5976	0.8964	0.9711	0.1494
LKF	2.71	0.3735	1.49	1.49	5.90	3.36	-	1.41	0.747	0.5229	0.5229
HUM	1.12	0.3735	0.8217	0.8964	0.747	1.56	1.19	-	0.747	0.8217	0.3735
CTO	0.2715	0.3735	0.0373	0.2988	3.06	2.39	0.9711	0.6723	-	0.4482	0.3735
MTV	1.10	0.0373	0.0747	0.1494	0.747	1.49	0.9711	0.4482	0.8964	-	0.2988
MTP	0.9774	0.3735	0.0747	0.0747	1.94	1.49	1.12	0.6723	0.0373	0.3735	-

TABLE A-9. PACIFIC AUTOVON TRAFFIC OFFERED (ERLANGS)

TO FROM	PRIORITY	CON (17)	WHW (12)	FGB (13)	CLK (14)	FTB (15)	FUU (16)
CON (17)	T		6.7000	2.9000	5.4000	6.1000	2.3000
	0		0.0067	0.0028	0.0053	0.0061	0.0022
	1		0.0669	0.0292	0.0542	0.0611	0.0231
	2		2.2714	0.2581	0.4806	0.5428	0.2047
	3		3.3500	1.1600	2.1600	2.4400	0.9200
4		1.0050	1.4500	2.7000	3.0500	1.1500	
WHW (12)	T	6.7000		2.5000	12.3000	5.1000	10.9000
	0	0.0067		0.0025	0.0122	0.0050	0.0109
	1	0.0669		0.0250	0.1231	0.0511	0.1090
	2	2.2714		0.8475	4.1697	1.7289	3.6950
	3	3.3500		1.2500	6.1500	2.5500	5.4500
4	1.0050		0.3750	1.8450	0.7650	1.6350	
FGB (13)	T	2.9000	2.4000		4.8000	0.9000	2.2000
	0	0.0000	0.0000		0.0000	0.0000	0.0000
	1	0.0292	0.0240		0.0481	0.0089	0.0220
	2	0.2608	0.8161		0.4319	0.0811	0.1980
	3	1.1600	1.2000		2.4961	0.4681	1.1440
4	1.4500	0.3600		1.8239	0.3419	0.8360	
CLK (14)	T	5.4000	7.3000	1.8000		3.4000	3.7000
	0	0.0000	0.0000	0.0000		0.0000	0.0000
	1	0.0542	0.0730	0.0180		0.0339	0.0370
	2	0.4858	2.4819	0.1620		0.3061	0.3330
	3	2.1600	3.6500	0.9360		1.7681	1.9240
4	2.7000	1.0950	0.6840		1.2919	1.4060	
FTB (15)	T	6.1000	7.2000	0.7000	4.0000		3.0000
	0	0.0000	0.0000	0.0000	0.0000		0.0000
	1	0.0611	0.0719	0.0070	0.0400		0.0300
	2	0.5489	2.4481	0.0630	0.3600		0.2700
	3	2.4400	3.6000	0.3639	2.0800		1.5600
4	3.0500	1.0800	0.2661	1.5200		1.1400	
FUU (16)	T	2.3000	14.5000	3.1000	3.5000	3.0000	
	0	0.0000	0.0000	0.0000	0.0000	0.0000	
	1	0.0231	0.1450	0.0311	0.0350	0.0300	
	2	0.2069	4.9300	0.2789	0.3150	0.2700	
	3	0.9200	7.2500	1.6119	1.8200	1.5600	
4	1.1500	2.1750	1.1781	1.3300	1.1400		

APPENDIX B

SIMULATOR COMMAND INPUTS

This appendix lists the current batch mode and immediate action command options available to the simulation controller. The interactive options are detailed in the interim report (Reference 1). In the following tables, immediate action commands are alphabetic, while batch mode options utilize a numeric command code.

THIS PAGE IS BEST QUALITY PRACTICABLE
FROM COPY FURNISHED TO DDC

IMMEDIATE ACTION COMMAND OPTIONS

COMMAND	ARGUMENT	DESCRIPTION
AB		ABORT PROGRAM EXECUTION.
AS		REASSIGN LOGICAL UNITS INDICATED ON LINES FOLLOWING. TERMINATE ENTRY WITH A BLANK CARD. LU IS LOGICAL UNIT NUMBER AND DEVICE IS PHYSICAL DEVICE NAME IN (I2,4X,5A4) FIXED FORMAT
	LU DEVICE	
AS	I1,A2,A3	REASSIGN LU *I1* TO DEVICE*A2* WITH RESTRICTIONS *A3* (ERO,RRW,...)
ASS	I1,A2,A3	ASSIGN AS ABOVE FROM CON TASK FOR SIM TASK
B	I1	CHANGE TEKTRONIX BAUD RATE TO *I1*.
C		START OR CONTINUE RUN WITH NO INITIALIZATION.
CA	I1	CALIBRATE STRIPLOT RECORDERS. SET ALL STRIPLOT PENS TO *I1* PERCENT OF FULL SCALE.
CI		COPY COMMON PARAMETERS INTO CON TASK FROM SIM.
CO		COPY COMMON PARAMETERS FROM CON TASK INTO SIM.
DQ	I1	DATSEQ: NORMAL NETWORK DEFINITION DATA SEQUENCE FROM *I1*
DW	I1	DATSEW: DISPLAY NETWORK DEFINITION DATA ARRAYS TO *I1*
E		ECHO THE INPUT DATA.
G		INITIALIZE RUN TO IT=0 ONLY AND START INTERACTIVE RUN.
H		HALT INTERACTIVE RUN.
HC		COPY TEKTRONIX SCREEN.
M		NO ECHO OF INPUT DATA.
P		PAGE TEKTRONIX SCREEN.
PR		CHANGE PARAMETERS INDICATED ON LINES FOLLOWING. TERMINATE INPUT WITH BLANK CARD. (DETAILED KNOWLEDGE OF PROGRAM REQUIRED)
R		RESET DATA BASE.
RS	FILENAME	RESTORE REFINED DATA FILE CALLED FILENAME.
RW	I1	REWIND LOGICAL UNIT *I1*.

IMMEDIATE ACTION COMMAND OPTIONS (CONTINUED)

COMMAND	ARGUMENT	DESCRIPTION
S		INITIALIZE AND START INTERACTIVE RUN.
ST	I1	RESTART SIM TASK AT HEXIDECIMAL LOCATION *I1*.
SV	FILENAME	SAVE THE REFINED DATA INTO FILENAME.
T	I1	SET TIME SCALE TO *I1*.
W		WINDOW THE DATA BASE.
WT	I1	WAIT (I1)/10 SECONDS
X	I1,I2	INTERACTIVE EMULATOR. PRINT CHARACTER (I1)/10 SECONDS AFTER ENTRY AND DELAY (I2)/10 SECONDS BETWEEN CHARACTERS.

**THIS PAGE IS BEST QUALITY PRACTICABLE
FROM COPY FURNISHED TO RDC**

COMMAND (I0)	NUMBER OF ARGUMENTS (I1,I2,....)	EXPLANATION
-	2	MANUAL CALL TERMINATION: TERMINATE THE *I1* THROUGH *I2* CALLS IN ROUTE QUEUE IF (I2.LE.I1) I2=I1 REQUIRES SOME PROGRAM KNOWLEDGE TO DETERMINE LOCATION OF CALLS TO BE TERMINATED
0 1-899	3	NO-OPERATION MANUAL CALL PLACEMENT OF *I3* CALLS EACH OF PRIORITIES *I1* THROUGH *I2* FOR CALL COMBINATION *I0* IF (I1.LT.0.OR.I1.GE.IPR) I1=0 AND I2=IPR-1 WHERE IPR IS NUMBER OF PRIORITIES IF (I2.LE.I1) I2=I1 IF (I3.LE.0) I3=1
900		RETURN TO INTERACTIVE/CONVERSATIONAL MODE
901		INITIALIZE NETWORK IF *I1* IS ZERO OR BLANK THEN COMPLETE INITIALIZATION FOR NOMINAL RUN IF *I1* IS 1:INITIALIZE DATA BASE IF *I1* IS 2:INITIALIZE CONTROLS IF *I1* IS 3:INITIALIZE ROUTE STORAGE TABLES IF *I1* IS 4:INITIALIZE RUN
902	1	BATCH MODE COMMAND ECHO I1=0 :NO ECHO I1=1 :ECHO
903	1	BAUD RATE (FOR TEKTRONIX) =*I1*
904		HARD COPY TEKTRONIX
905		PAGE TEKTRONIX
906		HARD COPY AND PAGE TEKTRONIX
907	1	WAIT *I1* TENTHS OF A SECOND
908	2	I/O UNIT CHANGE FOR BATCH MODE *I1* :INPUT UNIT LOGICAL UNIT NUMBER *I2* :OUTPUT UNIT LOGICAL UNIT NUMBER NO CHANGE OF BLANK OR ZERO REWIND BEFORE TRANSFER IF NEGATIVE
910	*	TIME SCALE : NEXT INPUT LINE IS: ISYNC,STSCAL,STSCOX WHERE: ISYNC=0 FOR ASYNCHRONOUS,1 FOR SYNCHRONOUS STSCAL IS DESIRED TIME SCALE (INTEGER) STSCOX IS ALLOWABLE TIMING JITTER IN MSEC IF STSCAL OR STSCOX.LE.0 THEN IT IS UNCHANGED

THIS PAGE IS BEST QUALITY PRACTICABLE
 FROM COPY FURNISHED TO DDC

BATCH MODE COMMAND OPTIONS (CONTINUED)

COMMAND (IO)	NUMBER OF ARGUMENTS (I1,I2,...)	EXPLANATION
911	3	TIME INTERVALS IDT =*I1* :NO.OF TIME FRAMES/SYNCH.INTERV. IDTPR=*I2* :NO.OF TIME FRAMES/TIME PRINT IDTST=*I3* :NO.OF TIME FRAMES/STRIP-PLOT IF INPUT VALUE ZERO OR BLANK : NO CHANGE IF INPUT VALUE NEGATIVE, RESULTANT IS ZERO
915	*	REFINED DATA :NEXT LINE IS IRW FILNAM WHERE: IRW=1 : READ IRW=2 : WRITE FILNAM: DISCFILE OF DEVICE NAME IF FILNAM DOESN'T EXIST THEN AN ATTEMPT WILL BE MADE TO ALLOCATE A CONTIG- UOUS FILE OF SUFFICIENT SIZE
920-927		**STRIPLOT** STRIPLOT DEFINITIONS NEXT INPUT LINE IS NST,IDTST,OUSTR WHERE NST=NO. OF CHANNELS IDTST=NO. OF TIME INTERVALS/PLOT OUSTR=LOGICAL UNIT NO. FOR STRIPLOT IF VALUE=0 OR BLANK THEN NO CHANGE IF IDTST,LT.0 THEN IDTST=0 AND NO PLOT SUBSEQUENT INPUT LINES ARE ICH,ITYPE,IARG UNTIL ICH=0 OR BLANK WHERE ICH IS CHANNEL NO. ITYPE IS PLOT TYPE IARG IS ARGUMENT FOR TYPE (SEE INTERACTIVE OPTION LIST)
921		STRPPL: PLOT CURRENT BUFFER
922		STRPGO: START STRIPLOT DRIVE
923		STRPHL: HALT STRIPLOT DRIVE
924		STRPRT: GENERATE RIGHT-HAND TIC MARK
925		STRPLT: GENERATE LEFT-HAND TIC MARK
926		STRPIN: INITIALIZE STRIPLOT ROUTINES
927	1	STRPCA: SEND CAL-SIGNAL OF *I1* PERCENT OF FULL SCALE
930	2	NETPLT: GENERATE NETWORK DIAGRAM FOR NODES *I1* THROUGH *I2 WITH DEFAULTS OF NETWORK SIZE
931		EORSUM: GENERATE END OF RUN SUMMARY
932	1	SUMMRY: GENERATE PARAMETER SUMMARY AND INCREMENT RUN NO. IF *I1*=0 SET RUN NO. = *I1* IF *I1*.GT.0
933		COPIN : COPY COMMON PARAMETERS FROM SIM TO CON
934		COPOUT: COPY COMMON PARAMETERS FROM CON TO SIM
935	**	READPL(IUM,OUM): ROUTINE TO INPUT PLOTTING PARAMETERS

BATCH MODE COMMAND OPTIONS (CONTINUED)

COMMAND (I0)	NUMBER OF ARGUMENTS (I1,I2,....)	EXPLANATION
936	**	READTM(IUM, OUM): ROUTINE TO INPUT COMMON EQUIPMENT DELAY PARAMETERS
937	**	READQM(IUM, OUM): ROUTINE TO ALTER CHRONOLOGICAL QUEUE SIZE
938	2	READ NEW TRUNK AND RSJ MAXIMUM CAPACITIES FROM *LU1* AND CHANGE CHRONOLOGICAL QUEUE SIZE TO *I2* ELEMENTS IF *I2*.GT.0
940-945	5	**ROUTING TABLE DISPLAYS** DISPLAY ROUTING TABLE FROM NODES *I1* THROUGH *I2* TO NODES *I3* THROUGH *I4* TO LOGICAL UNIT *I5* IF(I5.LE.0) LOGICAL UNIT=CURRENT OUTPUT UNIT DEFAULT OF *I1* AND *I3* YIELDS FROM AND/OR TO ALL NODES RESPECTIVELY DEFAULT OF *I2* AND *I4* YIELDS SINGLE NODE (OR ALL) DESIGNATED BY *I1* AND *I3* RESPECTIVELY
940	5	DSRTNN:NODE TO NODE ROUTING TABLE FORMAT
941	5	DSKTPT:NODE TO NODE PATH FORMAT
942	5	DSRTPA:NODE TO NODE PATH FORMAT:HEADER ONLY
943	5	DSRPPX:NODE TO NODE PATH FORMAT:DATA ONLY
945	6	ROUTING PLAN VERIFIER. *I6* IS FORMAT CODE
950	**	**PERTRB** : GO TO PERTURBATION MODULE: SUBSEQUENT INPUT SAME AS INTERACTIVE OPTIONS

**THIS PAGE IS BEST QUALITY PRACTICABLE
FROM COPY FURNISHED TO DDC**

BATCH MODE COMMAND OPTIONS (CONTINUED)

COMMAND (I0)	NUMBER OF ARGUMENTS (I1,I2,....)	EXPLANATION
960-979	5	**DISPLAY OPTIONS** *I5* IS LOGICAL UNIT OF DESIRED OUTPUT DEV. DEFAULT IS CURRENT OUTPUT UNIT *I1* THROUGH *I4* LIMIT DISPLAY RANGE DEFAULTS GENERATE ENTIRE DISPLAY SEE INTERACTIVE OPTIONS FOR EXAMPLES OF DISPLAYS
960	5	DSNOCC: NODE(*I1**I2*) OCCUPANCY
961	5	DSLOCC: LINK(*I1**I2*) OCCUPANCY
962	5	DSLGSA: ACCUMULATED LINK (*I1**I2*) STATISTICS
963	5	DSNGSA: ACCUMULATED NODE (*I1**I2*) STATISTICS
964	5	DSTNGA: ACCUMULATED TOTAL NETWORK STATISTICS
965	5	DSPRNA: ACCUMULATED NETWORK BY PRECEDENCE (*I1**I2*) STATISTICS
966	5	DSNPNA: ACCUMULATED NODE (*I1**I2*) BY PRECEDENCE (*I3**I4*) NETWORK STATISTICS
968	5	DSNNNA: ACCUMULATED NODE (*I1**I2*) TO NODE (*I3**I4*) NETWORK STATISTICS
969	5	DSSNNA: ACCUMULATED SOURCE NODE (*I1**I2*) NETWORK STATISTICS
970		DSNPOC: NODE (*I1**I2*) BY PRIORITY (*I3**I4*) OCCUPANCY
971		DSLPOC: LINK (*I1**I2*) BY PRIORITY (*I3**I4*) OCCUPANCY
972		DSLPPRA: ACCUMULATED LINK (*I1**I2*) BY PRIORITY (*I3**I4*) PREEMPTION STATISTICS
973		DSNPRA: ACCUMULATED NODE (*I1**I2*) BY PRIORITY (*I3**I4*) PREEMPTION STATISTICS
974		DSTNUA: ACCUMULATED TOTAL NETWORK USER STATISTICS
975		DSPRUA: ACCUMULATED NETWORK BY PRECEDENCE (*I1**I2*) USER STATISTICS
976		DSNPUA: ACCUMULATED NODE (*I1**I2*) BY PRECEDENCE (*I3**I4*) USER STATISTICS
978		DSNNUA: ACCUMULATED NODE (*I1**I2*) TO NODE (*I3**I4*) USER STATISTICS
979		USSNUA: ACCUMULATED SOURCE NODE (*I1**I2*) USER STATISTICS
980	**	**CONTRL** GO TO CONTROL MODULE: SUBSEQUENT INPUT SAME AS INTERACTIVE OPTIONS
990		DBRSAL: RESET ENTIRE STATISTICAL DATA BASE
991		DBWIND: WINDOW THE WINDOWABLE DATA BASE
992		DBRSLN: RESET LINK AND NODE STATISTICAL DATA BASE

BATCH MODE COMMAND OPTIONS (CONTINUED)

COMMAND (I0)	NUMBER OF ARGUMENTS (I1,I2,...)	EXPLANATION
1000	**	PARCH : PARAMETER CHANGE ROUTINE REQUIRES SOME PROGRAM KNOWLEDGE FOR EXECUTION (ENTER BLANK TO RESUME BATCH INPUT)
9000-9010	1	**RUN CONTROL** *I1* RELATES TO ITMX (MAX TIME) IF(I1.GT.0) ITMX=I1 IF(I1.LT.0) ITMX=ITMX-I1
9000	1	BCNSIM: START (OR CONTINUE) BATCH RUN -NO INITIALIZATION
9001	1	BGOSIM: INIT RUN TO IT=0 ONLY AND START BATCH RUN
9002	1	BSTSIM: INITIALIZE AND START BATCH RUN
9003	1	CNTSIM: START (OR CONTINUE) INTERACTIVE RUN WITH NO INITIALIZATION
9004	1	GOSIM : INIT RUN TO IT=0 ONLY AND START INTER- ACTIVE RUN
9005	1	STRSIM: INITIALIZE AND START INTERACTIVE RUN
9006	1	HLTSIM: HALT INTERACTIVE RUN
9010	1	RUNINC: IRUN=IRUN+1 IF *I1*.LE.0 INCREMENT RUN IF *I1*.GT.0 IRUN=I1

APPENDIX C

BASELINE SCENARIOS

Presented in this appendix are interactive network simulator digital displays and analog strip chart recordings for the unperturbed DCS network configuration, which is the baseline for the scenarios discussed in paragraph 1.3. Section I of this appendix contains digital display data for baseline scenario SC1100 at 45 minutes, 1 hour, and 4 hours, and stripchart recordings for 30 minutes through 1 hour. Section II contains the same data for baseline scenario SC1300.

SECTION I

DIGITAL DISPLAY DATA AND STRIPCHART RECORDINGS FOR BASELINE SCENARIO SC1100

***** 0:45: 0*****

ACCUMULATED TOTAL NETWORK STATISTICS
ATTEMPTS BLOCKS COMPLETE PREEMPTED BL/ATT PR/COM
1294 97 1197 86 0.0750 0.0718

***** 0:45: 0*****

ACCUMULATED NETWORK PRECEDENCE STATISTICS
PREC ATTEMPTS BLOCKS COMPLETE PREEMPTED BL/ATT PR/COM PREC
0 0 0 0 0 0.0000 0.0000 0
1 2 0 2 0 0.0000 0.0000 1
2 373 0 373 0 0.0000 0.0000 2
3 71 0 71 0 0.0000 0.0000 3
4 848 97 751 86 0.1144 0.1145 4

***** 0:45: 0*****

*ACCUMULATED LINK/PRIORITY GOS STATUS

LINK A	TOTAL	P0	P1	P2	P3	P4
	BLCK/ATTM=X.XX	BLCK/ATTM	BLCK/ATTM	BLCK/ATTM	BLCK/ATTM	BLCK/ATTM
1**	258/ 439=0.59	0/ 0	0/ 1	135/ 239	0/ 0	123/ 199
2**	332/ 507=0.65	0/ 0	1/ 2	167/ 285	0/ 0	164/ 220
3**	126/ 189=0.67	0/ 0	0/ 0	72/ 114	0/ 0	54/ 75
4**	147/ 261=0.56	0/ 0	0/ 0	68/ 133	0/ 0	79/ 128
5	1/ 111=0.01	0/ 0	0/ 1	0/ 58	0/ 0	1/ 52
6	0/ 75=0.00	0/ 0	0/ 0	0/ 37	0/ 1	0/ 37
7	7/ 80=0.09	0/ 0	0/ 0	4/ 38	0/ 0	3/ 42
8	0/ 81=0.00	0/ 0	0/ 0	0/ 30	0/ 2	0/ 49
9 *	20/ 60=0.33	0/ 0	0/ 0	5/ 16	0/ 0	15/ 44
10	5/ 51=0.10	0/ 0	0/ 0	2/ 21	1/ 2	2/ 28
11	0/ 180=0.00	0/ 0	0/ 0	0/ 76	0/ 9	0/ 95
12	0/ 91=0.00	0/ 0	0/ 0	0/ 44	0/ 2	0/ 45
13	0/ 32=0.00	0/ 0	0/ 0	0/ 10	0/ 0	0/ 22
14	0/ 38=0.00	0/ 0	0/ 0	0/ 7	0/ 4	0/ 27
15	9/ 217=0.04	0/ 0	0/ 0	2/ 50	1/ 13	6/ 154
16	3/ 35=0.09	0/ 0	0/ 0	0/ 4	2/ 6	1/ 25
17	0/ 25=0.00	0/ 0	0/ 0	0/ 3	0/ 2	0/ 20
18	2/ 168=0.01	0/ 0	0/ 0	2/ 35	0/ 15	0/ 118
19	0/ 40=0.00	0/ 0	0/ 0	0/ 3	0/ 3	0/ 34
20	1/ 56=0.02	0/ 0	0/ 0	0/ 15	0/ 4	1/ 37
21	2/ 29=0.07	0/ 0	0/ 0	0/ 5	1/ 6	1/ 18
22	2/ 84=0.02	0/ 0	0/ 0	0/ 28	0/ 5	2/ 51
23	14/ 84=0.17	0/ 0	0/ 0	2/ 15	0/ 2	12/ 67
24	0/ 44=0.00	0/ 0	0/ 0	0/ 3	0/ 7	0/ 34
25	8/ 62=0.13	0/ 0	0/ 0	1/ 6	0/ 4	7/ 52
26	0/ 45=0.00	0/ 0	0/ 0	0/ 2	0/ 8	0/ 35
27	11/ 41=0.27	0/ 0	0/ 0	0/ 0	2/ 5	9/ 36

***** 0:45: 0*****

ACCUMULATED SOURCE NODE NETWORK STATISTICS

NODE	ATTEMPTS	BLOCKS	COMPLETE	PREEMPTED	BL/ATT	PR/COM	NODE
1	188	23	165	34	0.1223	0.2061	1
2	93	6	87	12	0.0645	0.1379	2
3	202	13	189	7	0.0644	0.0370	3
4	181	10	171	7	0.0552	0.0409	4
5	67	8	59	5	0.1194	0.0847	5
6	81	5	76	3	0.0617	0.0395	6
7	55	1	54	1	0.0182	0.0185	7
8	187	19	168	8	0.1016	0.0476	8
9	89	2	87	2	0.0225	0.0230	9
10	62	2	60	3	0.0323	0.0500	10
11	89	8	81	4	0.0899	0.0494	11

THIS PAGE IS BEST QUALITY PRACTICABLE
 FROM COPY FURNISHED TO DDC

***** 0:45: 0*****

ACCUMULATED NODE TO NODE NETWORK STATISTICS										
NODE	NODE	ATTEMPTS	BLOCKS	COMPLETE	PREEMPTED	BL/ATT	PR/COM	NODE	NODE	
2	1	60	6	54	12	0.1000	0.2222	2	1	
3	1	74	13	61	7	0.1757	0.1148	3	1	
4	1	74	10	64	7	0.1351	0.1094	4	1	
5	1	38	7	31	5	0.1842	0.1613	5	1	
6	1	28	4	24	3	0.1429	0.1250	6	1	
7	1	8	1	7	1	0.1250	0.1429	7	1	
8	1	86	19	67	8	0.2209	0.1194	8	1	
9	1	24	2	22	2	0.0833	0.0909	9	1	
10	1	7	1	6	2	0.1429	0.3333	10	1	
11	1	35	8	27	4	0.2286	0.1481	11	1	
1	2	34	8	26	5	0.2353	0.1923	1	2	
4	2	5	0	5	0	0.0000	0.0000	4	2	
6	2	1	0	1	0	0.0000	0.0000	6	2	
7	2	1	0	1	0	0.0000	0.0000	7	2	
8	2	4	0	4	0	0.0000	0.0000	8	2	
9	2	3	0	3	0	0.0000	0.0000	9	2	
11	2	2	0	2	0	0.0000	0.0000	11	2	
1	3	33	5	28	6	0.1515	0.2143	1	3	
2	3	1	0	1	0	0.0000	0.0000	2	3	
4	3	31	0	31	0	0.0000	0.0000	4	3	
5	3	3	0	3	0	0.0000	0.0000	5	3	
6	3	1	0	1	0	0.0000	0.0000	6	3	
7	3	7	0	7	0	0.0000	0.0000	7	3	
8	3	36	0	36	0	0.0000	0.0000	8	3	
9	3	4	0	4	0	0.0000	0.0000	9	3	
10	3	20	1	19	1	0.0500	0.0526	10	3	
11	3	13	0	13	0	0.0000	0.0000	11	3	
1	4	37	2	35	10	0.0541	0.2857	1	4	
2	4	3	0	3	0	0.0000	0.0000	2	4	
3	4	32	0	32	0	0.0000	0.0000	3	4	
5	4	7	0	7	0	0.0000	0.0000	5	4	
6	4	12	0	12	0	0.0000	0.0000	6	4	
7	4	14	0	14	0	0.0000	0.0000	7	4	
8	4	27	0	27	0	0.0000	0.0000	8	4	
9	4	12	0	12	0	0.0000	0.0000	9	4	
10	4	6	0	6	0	0.0000	0.0000	10	4	
11	4	6	0	6	0	0.0000	0.0000	11	4	
1	5	14	1	13	2	0.0714	0.1538	1	5	
3	5	4	0	4	0	0.0000	0.0000	3	5	
4	5	5	0	5	0	0.0000	0.0000	4	5	
8	5	8	0	8	0	0.0000	0.0000	8	5	
9	5	7	0	7	0	0.0000	0.0000	9	5	
10	5	3	0	3	0	0.0000	0.0000	10	5	
11	5	12	0	12	0	0.0000	0.0000	11	5	
1	6	11	1	10	0	0.0909	0.0000	1	6	
2	6	17	0	17	0	0.0000	0.0000	2	6	
3	6	3	0	3	0	0.0000	0.0000	3	6	
4	6	9	0	9	0	0.0000	0.0000	4	6	
7	6	1	0	1	0	0.0000	0.0000	7	6	
8	6	4	0	4	0	0.0000	0.0000	8	6	
9	6	9	0	9	0	0.0000	0.0000	9	6	

THIS PAGE IS BEST QUALITY PRACTICABLE
 FROM COPY FURNISHED TO DDC

1	7	4	1	3	1	0.2500	0.3333	1	7
2	7	1	0	1	0	0.0000	0.0000	2	7
3	7	20	0	20	0	0.0000	0.0000	3	7
4	7	10	0	10	0	0.0000	0.0000	4	7
5	7	1	0	1	0	0.0000	0.0000	5	7
6	7	1	0	1	0	0.0000	0.0000	6	7
8	7	7	0	7	0	0.0000	0.0000	8	7
9	7	4	0	4	0	0.0000	0.0000	9	7
10	7	1	0	1	0	0.0000	0.0000	10	7
11	7	1	0	1	0	0.0000	0.0000	11	7
1	8	30	2	28	6	0.0667	0.2143	1	8
2	8	8	0	8	0	0.0000	0.0000	2	8
3	8	56	0	56	0	0.0000	0.0000	3	8
4	8	35	0	35	0	0.0000	0.0000	4	8
5	8	7	0	7	0	0.0000	0.0000	5	8
6	8	28	1	27	0	0.0357	0.0000	6	8
7	8	19	0	19	0	0.0000	0.0000	7	8
9	8	19	0	19	0	0.0000	0.0000	9	8
10	8	19	0	19	0	0.0000	0.0000	10	8
11	8	15	0	15	0	0.0000	0.0000	11	8
1	9	15	2	13	3	0.1333	0.2308	1	9
2	9	2	0	2	0	0.0000	0.0000	2	9
3	9	1	0	1	0	0.0000	0.0000	3	9
4	9	6	0	6	0	0.0000	0.0000	4	9
5	9	2	0	2	0	0.0000	0.0000	5	9
6	9	5	0	5	0	0.0000	0.0000	6	9
7	9	3	0	3	0	0.0000	0.0000	7	9
8	9	9	0	9	0	0.0000	0.0000	8	9
10	9	5	0	5	0	0.0000	0.0000	10	9
11	9	5	0	5	0	0.0000	0.0000	11	9
1	10	1	0	1	0	0.0000	0.0000	1	10
3	10	6	0	6	0	0.0000	0.0000	3	10
4	10	3	0	3	0	0.0000	0.0000	4	10
5	10	7	0	7	0	0.0000	0.0000	5	10
6	10	3	0	3	0	0.0000	0.0000	6	10
7	10	2	0	2	0	0.0000	0.0000	7	10
8	10	6	0	6	0	0.0000	0.0000	8	10
9	10	5	0	5	0	0.0000	0.0000	9	10
1	11	9	1	8	1	0.1111	0.1250	1	11
2	11	1	0	1	0	0.0000	0.0000	2	11
3	11	6	0	6	0	0.0000	0.0000	3	11
4	11	3	0	3	0	0.0000	0.0000	4	11
5	11	2	1	1	0	0.5000	0.0000	5	11
6	11	2	0	2	0	0.0000	0.0000	6	11
9	11	2	0	2	0	0.0000	0.0000	9	11
10	11	1	0	1	0	0.0000	0.0000	10	11

THIS PAGE IS BEST QUALITY PRACTICABLE
FROM COPY FURNISHED TO DDC

***** 1: 0: 0*****
ACCUMULATED TOTAL NETWORK STATISTICS
ATTEMPTS BLOCKS COMPLETE PREEMPTED BL/ATT PR/COM
1300 132 1168 129 0.1015 0.1104

***** 1: 0: 0*****
ACCUMULATED NETWORK PRECEDENCE STATISTICS
PREC ATTEMPTS BLOCKS COMPLETE PREEMPTED BL/ATT PR/COM PREC
0 0 0 0 0 0.0000 0.0000 0
1 3 0 3 0 0.0000 0.0000 1
2 380 1 379 1 0.0026 0.0026 2
3 80 0 80 0 0.0000 0.0000 3
4 837 131 706 128 0.1565 0.1813 4

***** 1: 0: 0*****
*ACCUMULATED LINK/PRIORITY GOS STATUS

LINK A	TOTAL	P0	P1	P2	P3	P4
	BLCK/ATTM=X,XX	BLCK/ATTM	BLCK/ATTM	BLCK/ATTM	BLCK/ATTM	BLCK/ATTM
1**	306/ 511=0.60	0/ 0	3/ 4	155/ 284	0/ 0	148/ 223
2**	375/ 545=0.69	0/ 0	3/ 4	208/ 309	0/ 0	164/ 232
3**	157/ 218=0.72	0/ 0	1/ 2	89/ 126	0/ 0	67/ 90
4**	194/ 300=0.65	0/ 0	2/ 2	101/ 174	0/ 0	91/ 124
5	0/ 107=0.00	0/ 0	0/ 1	0/ 48	0/ 0	0/ 58
6	0/ 90=0.00	0/ 0	0/ 0	0/ 37	0/ 1	0/ 52
7	8/ 101=0.08	0/ 0	0/ 1	3/ 53	0/ 0	5/ 47
8	0/ 119=0.00	0/ 0	0/ 1	0/ 39	0/ 3	0/ 76
9 *	44/ 93=0.47	0/ 0	0/ 0	24/ 43	1/ 4	19/ 46
10	12/ 70=0.17	0/ 0	1/ 1	3/ 31	0/ 1	8/ 37
11	18/ 193=0.09	0/ 0	0/ 0	8/ 76	0/ 10	10/ 107
12	0/ 107=0.00	0/ 0	0/ 1	0/ 49	0/ 2	0/ 55
13	0/ 45=0.00	0/ 0	0/ 0	0/ 12	0/ 3	0/ 30
14	0/ 40=0.00	0/ 0	0/ 0	0/ 8	0/ 3	0/ 29
15	37/ 254=0.15	0/ 0	0/ 1	7/ 80	1/ 13	29/ 160
16	7/ 42=0.17	0/ 0	0/ 0	1/ 9	0/ 6	6/ 27
17	1/ 29=0.03	0/ 0	0/ 0	0/ 3	0/ 4	1/ 22
18	16/ 194=0.08	0/ 0	0/ 0	6/ 32	0/ 17	10/ 145
19	0/ 43=0.00	0/ 0	0/ 0	0/ 4	0/ 5	0/ 34
20	0/ 61=0.00	0/ 0	0/ 1	0/ 17	0/ 5	0/ 38
21	0/ 34=0.00	0/ 0	0/ 0	0/ 4	0/ 5	0/ 25
22	2/ 64=0.03	0/ 0	0/ 0	0/ 25	0/ 3	2/ 36
23 *	46/ 98=0.47	0/ 0	0/ 0	9/ 12	4/ 9	33/ 77
24	1/ 48=0.02	0/ 0	0/ 0	0/ 9	0/ 3	1/ 36
25	4/ 54=0.07	0/ 0	0/ 0	1/ 6	0/ 10	3/ 38
26	2/ 40=0.05	0/ 0	0/ 0	1/ 6	0/ 3	1/ 31
27	8/ 33=0.24	0/ 0	0/ 0	0/ 1	2/ 3	6/ 29

***** 1: 0: 0*****
ACCUMULATED SOURCE NODE NETWORK STATISTICS
ATTEMPTS BLOCKS COMPLETE PREEMPTED BL/ATT PR/COM NODE

1	193	36	157	43	0.1865	0.2739	1
2	110	11	99	15	0.1000	0.1515	2
3	188	17	171	15	0.0904	0.0877	3
4	198	15	183	10	0.0758	0.0546	4
5	70	6	64	5	0.0857	0.0781	5
6	84	6	78	4	0.0714	0.0513	6
7	55	1	54	2	0.0182	0.0370	7
8	193	24	169	18	0.1244	0.1065	8
9	85	6	79	8	0.0706	0.1013	9
10	58	3	55	3	0.0517	0.0545	10
11	66	7	59	6	0.1061	0.1017	11

THIS PAGE IS BEST QUALITY PRACTICABLE
FROM COPY FURNISHED TO DDC

***** 1: 0: 0*****

ACCUMULATED NODE TO NODE NETWORK STATISTICS

NODE	NODE	ATTEMPTS	BLCKS	COMPLETE	PREEMPTED	BL/ATT	PR/COM	NODE	NODE
2	1	64	10	54	14	0.1562	0.2593	2	1
3	1	77	17	60	13	0.2208	0.2167	3	1
4	1	75	15	60	9	0.2000	0.1500	4	1
5	1	34	6	28	5	0.1765	0.1786	5	1
6	1	29	5	24	4	0.1724	0.1667	6	1
7	1	9	1	8	2	0.1111	0.2500	7	1
8	1	103	24	79	17	0.2330	0.2152	8	1
9	1	33	6	27	7	0.1818	0.2593	9	1
10	1	9	1	8	3	0.1111	0.3750	10	1
11	1	31	6	25	6	0.1935	0.2400	11	1
1	2	31	8	23	7	0.2581	0.3043	1	2
4	2	3	0	3	0	0.0000	0.0000	4	2
6	2	1	0	1	0	0.0000	0.0000	6	2
7	2	1	0	1	0	0.0000	0.0000	7	2
8	2	1	0	1	0	0.0000	0.0000	8	2
9	2	2	0	2	0	0.0000	0.0000	9	2
11	2	2	1	1	0	0.5000	0.0000	11	2
1	3	30	4	26	4	0.1333	0.1538	1	3
4	3	38	0	38	1	0.0000	0.0263	4	3
5	3	2	0	2	0	0.0000	0.0000	5	3
6	3	2	0	2	0	0.0000	0.0000	6	3
7	3	9	0	9	0	0.0000	0.0000	7	3
8	3	34	0	34	1	0.0000	0.0294	8	3
9	3	9	0	9	0	0.0000	0.0000	9	3
10	3	19	1	18	0	0.0526	0.0000	10	3
11	3	15	0	15	0	0.0000	0.0000	11	3
1	4	35	7	28	4	0.2000	0.1429	1	4
2	4	4	0	4	0	0.0000	0.0000	2	4
3	4	26	0	26	0	0.0000	0.0000	3	4
5	4	9	0	9	0	0.0000	0.0000	5	4
6	4	15	0	15	0	0.0000	0.0000	6	4
7	4	11	0	11	0	0.0000	0.0000	7	4
8	4	26	0	26	0	0.0000	0.0000	8	4
9	4	4	0	4	0	0.0000	0.0000	9	4
10	4	6	0	6	0	0.0000	0.0000	10	4
11	4	9	0	9	0	0.0000	0.0000	11	4
1	5	20	5	15	8	0.2500	0.5333	1	5
2	5	1	0	1	0	0.0000	0.0000	2	5
3	5	3	0	3	0	0.0000	0.0000	3	5
4	5	5	0	5	0	0.0000	0.0000	4	5
8	5	3	0	3	0	0.0000	0.0000	8	5
9	5	6	0	6	0	0.0000	0.0000	9	5
10	5	9	0	9	0	0.0000	0.0000	10	5
11	5	1	0	1	0	0.0000	0.0000	11	5
1	6	22	3	19	7	0.1364	0.3684	1	6
2	6	17	0	17	0	0.0000	0.0000	2	6
3	6	4	0	4	0	0.0000	0.0000	3	6
4	6	17	0	17	0	0.0000	0.0000	4	6
5	6	2	0	2	0	0.0000	0.0000	5	6
7	6	2	0	2	0	0.0000	0.0000	7	6
8	6	9	0	9	0	0.0000	0.0000	8	6
9	6	8	0	8	1	0.0000	0.1250	9	6

THIS PAGE IS BEST-QUALITY PRACTICABLE
 FROM COPY FURNISHED TO DDC

1	7	2	1	1	1	0.5000	1.0000	1	7
3	7	21	0	21	0	0.0000	0.0000	3	7
4	7	14	0	14	0	0.0000	0.0000	4	7
5	7	1	0	1	0	0.0000	0.0000	5	7
6	7	1	0	1	0	0.0000	0.0000	6	7
8	7	2	0	2	0	0.0000	0.0000	8	7
9	7	4	0	4	0	0.0000	0.0000	9	7
10	7	3	0	3	0	0.0000	0.0000	10	7
1	8	17	3	14	6	0.1765	0.4286	1	8
2	8	19	1	18	0	0.0526	0.0000	2	8
3	8	40	0	40	1	0.0000	0.0250	3	8
4	8	31	0	31	0	0.0000	0.0000	4	8
5	8	16	0	16	0	0.0000	0.0000	5	8
6	8	23	1	22	0	0.0435	0.0000	6	8
7	8	19	0	19	0	0.0000	0.0000	7	8
9	8	12	0	12	0	0.0000	0.0000	9	8
10	8	7	0	7	0	0.0000	0.0000	10	8
11	8	5	0	5	0	0.0000	0.0000	11	8
1	9	22	2	20	4	0.0909	0.2000	1	9
2	9	3	0	3	0	0.0000	0.0000	2	9
3	9	2	0	2	0	0.0000	0.0000	3	9
4	9	10	0	10	0	0.0000	0.0000	4	9
5	9	2	0	2	0	0.0000	0.0000	5	9
6	9	10	0	10	0	0.0000	0.0000	6	9
7	9	2	0	2	0	0.0000	0.0000	7	9
8	9	7	0	7	0	0.0000	0.0000	8	9
10	9	4	0	4	0	0.0000	0.0000	10	9
11	9	3	0	3	0	0.0000	0.0000	11	9
1	10	3	1	2	1	0.3333	0.5000	1	10
3	10	11	0	11	1	0.0000	0.0909	3	10
4	10	3	0	3	0	0.0000	0.0000	4	10
5	10	4	0	4	0	0.0000	0.0000	5	10
6	10	2	0	2	0	0.0000	0.0000	6	10
7	10	2	0	2	0	0.0000	0.0000	7	10
8	10	8	0	8	0	0.0000	0.0000	8	10
9	10	5	0	5	0	0.0000	0.0000	9	10
1	11	11	2	9	1	0.1818	0.1111	1	11
2	11	2	0	2	1	0.0000	0.5000	2	11
3	11	4	0	4	0	0.0000	0.0000	3	11
4	11	2	0	2	0	0.0000	0.0000	4	11
6	11	1	0	1	0	0.0000	0.0000	6	11
9	11	2	0	2	0	0.0000	0.0000	9	11
10	11	1	1	0	0	1.0000	0.0000	10	11

THIS PAGE IS BEST QUALITY PRACTICABLE
 FROM COPY FURNISHED TO DDC

***** 4: 0: 0*****
 ACCUMULATED TOTAL NETWORK STATISTICS
 ATTEMPTS BLOCKS COMPLETE PREEMPTED BL/ATT PR/COM
 20652 1853 18799 1692 0.0897 0.0900

***** 4: 0: 0*****
 ACCUMULATED NETWORK PRECEDENCE STATISTICS
 PREC ATTEMPTS BLOCKS COMPLETE PREEMPTED BL/ATT PR/COM PREC
 0 1 0 1 0 0.0000 0.0000 0
 1 46 0 46 0 0.0000 0.0000 1
 2 5982 29 5953 3 0.0048 0.0005 2
 3 1193 0 1193 0 0.0000 0.0000 3
 4 13430 1824 11606 1689 0.1358 0.1455 4

***** 4: 0: 0*****
 *ACCUMULATED LINK/PRIORITY GOS STATUS

LINK A	TOTAL	P0	P1	P2	P3	P4
	BLCK/ATTM=X.XX	BLCK/ATTM	BLCK/ATTM	BLCK/ATTM	BLCK/ATTM	BLCK/ATTM
1**	4753/7530=0.63	1/ 1	14/ 25	2506/4211	0/ 0	2232/3293
2**	5604/8409=0.67	1/ 2	20/ 38	2958/4728	0/ 0	2625/3641
3**	2252/3151=0.71	0/ 0	4/ 9	1245/1838	0/ 0	1003/1304
4**	2620/4496=0.58	1/ 1	11/ 14	1323/2483	0/ 0	1285/1998
5	1/1595=0.00	0/ 0	0/ 11	0/ 815	0/ 6	1/ 763
6	18/1425=0.01	0/ 0	0/ 6	9/ 635	0/ 21	9/ 763
7	183/1480=0.12	0/ 0	0/ 3	94/ 747	0/ 14	89/ 716
8	0/15/9=0.00	0/ 0	0/ 2	0/ 518	0/ 100	0/ 959
9 *	417/1122=0.37	0/ 0	1/ 2	164/ 404	11/ 39	241/ 677
10	78/ 993=0.08	0/ 0	1/ 2	31/ 417	1/ 39	45/ 535
11	132/3178=0.04	0/ 0	0/ 11	43/1233	4/ 159	85/1775
12	0/1661=0.00	0/ 0	0/ 3	0/ 758	0/ 37	0/ 863
13	0/ 647=0.00	0/ 0	0/ 0	0/ 224	0/ 34	0/ 389
14	7/ 722=0.01	0/ 0	0/ 0	0/ 162	2/ 56	5/ 504
15	196/3311=0.06	0/ 0	0/ 12	60/ 918	11/ 177	125/2204
16	53/ 687=0.08	0/ 0	0/ 0	9/ 98	7/ 72	37/ 517
17	21/ 415=0.05	0/ 0	0/ 0	1/ 27	4/ 40	16/ 348
18	172/3003=0.06	0/ 0	0/ 5	35/ 563	12/ 262	125/2173
19	0/ 666=0.00	0/ 0	0/ 0	0/ 51	0/ 90	0/ 525
20	10/1001=0.01	0/ 0	0/ 2	2/ 274	0/ 60	8/ 665
21	14/ 526=0.03	0/ 0	0/ 0	2/ 109	2/ 35	10/ 382
22	39/1169=0.03	0/ 0	0/ 4	10/ 390	3/ 65	26/ 710
23 *	519/1525=0.34	0/ 0	1/ 2	107/ 253	39/ 138	372/1132
24	61/ 799=0.08	0/ 0	0/ 0	4/ 121	12/ 79	45/ 599
25	100/ 868=0.12	0/ 0	0/ 0	14/ 86	13/ 82	73/ 700
26	53/ 830=0.06	0/ 0	0/ 0	7/ 99	4/ 87	42/ 644
27	148/ 617=0.24	0/ 0	0/ 1	9/ 41	22/ 66	117/ 509

THIS PAGE IS BEST QUALITY PRACTICABLE
FROM COPY FURNISHED TO DDC

***** 4: 0: 0*****

ACCUMULATED SOURCE NODE NETWORK STATISTICS							
NODE	ATTEMPTS	BLOCKS	COMPLETE	PREEMPTED	BL/ATT	PR/COM	NODE
1	3141	482	2659	563	0.1535	0.2117	1
2	1689	177	1512	177	0.1048	0.1171	2
3	2831	170	2661	171	0.0600	0.0643	3
4	3168	270	2898	193	0.0852	0.0666	4
5	1151	117	1034	109	0.1017	0.1054	5
6	1430	95	1335	59	0.0664	0.0442	6
7	824	31	793	31	0.0376	0.0391	7
8	2777	284	2493	190	0.1023	0.0762	8
9	1391	91	1300	85	0.0654	0.0654	9
10	1109	32	1077	30	0.0289	0.0279	10
11	1141	104	1037	84	0.0911	0.0810	11

***** 4: 0: 0*****

ACCUMULATED NODE TO NODE NETWORK STATISTICS									
NODE	NODE	ATTEMPTS	BLOCKS	COMPLETE	PREEMPTED	BL/ATT	PR/COM	NODE	NODE
2	1	994	173	821	170	0.1740	0.2071	2	1
3	1	943	155	788	153	0.1644	0.1942	3	1
4	1	1290	261	1029	177	0.2023	0.1720	4	1
5	1	544	115	429	108	0.2114	0.2517	5	1
6	1	446	87	359	54	0.1951	0.1504	6	1
7	1	166	30	136	30	0.1807	0.2206	7	1
8	1	1338	281	1057	184	0.2100	0.1741	8	1
9	1	527	90	437	80	0.1708	0.1831	9	1
10	1	133	18	115	27	0.1353	0.2348	10	1
11	1	469	91	378	76	0.1940	0.2011	11	1
1	2	526	109	417	87	0.2072	0.2086	1	2
3	2	4	0	4	0	0.0000	0.0000	3	2
4	2	42	0	42	0	0.0000	0.0000	4	2
5	2	4	0	4	0	0.0000	0.0000	5	2
6	2	63	0	63	0	0.0000	0.0000	6	2
7	2	7	0	7	0	0.0000	0.0000	7	2
8	2	50	0	50	0	0.0000	0.0000	8	2
9	2	42	0	42	1	0.0000	0.0238	9	2
10	2	5	0	5	0	0.0000	0.0000	10	2
11	2	31	1	30	2	0.0323	0.0667	11	2
1	3	539	77	462	102	0.1429	0.2208	1	3
2	3	9	0	9	0	0.0000	0.0000	2	3
4	3	655	4	651	14	0.0061	0.0215	4	3
5	3	73	0	73	0	0.0000	0.0000	5	3
6	3	35	0	35	0	0.0000	0.0000	6	3
7	3	130	0	130	0	0.0000	0.0000	7	3
8	3	471	0	471	1	0.0000	0.0021	8	3
9	3	78	0	78	1	0.0000	0.0128	9	3
10	3	356	8	348	2	0.0225	0.0057	10	3
11	3	208	2	206	2	0.0096	0.0097	11	3
1	4	594	89	505	90	0.1498	0.1782	1	4
2	4	74	0	74	0	0.0000	0.0000	2	4
3	4	496	5	491	9	0.0101	0.0183	3	4
5	4	120	1	119	0	0.0083	0.0000	5	4
6	4	192	0	192	1	0.0000	0.0052	6	4
7	4	164	1	163	0	0.0061	0.0000	7	4
8	4	423	2	421	3	0.0047	0.0071	8	4
9	4	120	0	120	2	0.0000	0.0167	9	4
10	4	113	0	113	0	0.0000	0.0000	10	4
11	4	126	3	123	2	0.0238	0.0163	11	4
1	5	266	48	218	60	0.1805	0.2752	1	5
2	5	4	0	4	0	0.0000	0.0000	2	5
3	5	44	0	44	0	0.0000	0.0000	3	5
4	5	55	0	55	0	0.0000	0.0000	4	5
6	5	3	0	3	0	0.0000	0.0000	6	5

THIS PAGE IS BEST QUALITY PRACTICABLE
 FROM COPY FURNISHED TO DDC

8	5	113	0	113	0	0.0000	0.0000	8	5
9	5	110	0	110	0	0.0000	0.0000	9	5
10	5	48	0	48	0	0.0000	0.0000	10	5
11	5	48	0	48	0	0.0000	0.0000	11	5
1	6	208	19	189	39	0.0913	0.2063	1	6
2	6	300	0	300	0	0.0000	0.0000	2	6
3	6	52	0	52	0	0.0000	0.0000	3	6
4	6	188	0	188	0	0.0000	0.0000	4	6
5	6	7	0	7	0	0.0000	0.0000	5	6
7	6	36	0	36	0	0.0000	0.0000	7	6
8	6	108	0	108	1	0.0000	0.0093	8	6
9	6	108	0	108	1	0.0000	0.0093	9	6
10	6	5	0	5	0	0.0000	0.0000	10	6
11	6	9	0	9	0	0.0000	0.0000	11	6
1	7	91	8	83	21	0.0879	0.2530	1	7
2	7	14	0	14	0	0.0000	0.0000	2	7
3	7	329	0	329	0	0.0000	0.0000	3	7
4	7	173	0	173	0	0.0000	0.0000	4	7
5	7	17	0	17	0	0.0000	0.0000	5	7
6	7	15	0	15	0	0.0000	0.0000	6	7
8	7	92	0	92	1	0.0000	0.0109	8	7
9	7	88	0	88	0	0.0000	0.0000	9	7
10	7	42	0	42	0	0.0000	0.0000	10	7
11	7	7	0	7	0	0.0000	0.0000	11	7
1	8	439	59	380	86	0.1344	0.2263	1	8
2	8	221	3	218	4	0.0136	0.0183	2	8
3	8	711	5	706	5	0.0070	0.0071	3	8
4	8	423	0	423	0	0.0000	0.0000	4	8
5	8	195	0	195	0	0.0000	0.0000	5	8
6	8	476	6	470	2	0.0126	0.0043	6	8
7	8	232	0	232	1	0.0000	0.0043	7	8
9	8	187	0	187	0	0.0000	0.0000	9	8
10	8	295	1	294	1	0.0034	0.0034	10	8
11	8	159	5	154	0	0.0314	0.0000	11	8
1	9	284	40	244	46	0.1408	0.1885	1	9
2	9	35	0	35	1	0.0000	0.0286	2	9
3	9	25	1	24	0	0.0400	0.0000	3	9
4	9	176	0	176	1	0.0000	0.0057	4	9
5	9	52	0	52	0	0.0000	0.0000	5	9
6	9	125	0	125	0	0.0000	0.0000	6	9
7	9	60	0	60	0	0.0000	0.0000	7	9
8	9	69	0	69	0	0.0000	0.0000	8	9
10	9	83	3	80	0	0.0361	0.0000	10	9
11	9	81	2	79	2	0.0247	0.0253	11	9
1	10	40	6	34	8	0.1500	0.2353	1	10
2	10	1	0	1	0	0.0000	0.0000	2	10
3	10	139	4	135	1	0.0288	0.0074	3	10
4	10	91	2	89	1	0.0220	0.0112	4	10
5	10	109	0	109	0	0.0000	0.0000	5	10
6	10	50	1	49	0	0.0200	0.0000	6	10
7	10	29	0	29	0	0.0000	0.0000	7	10
8	10	102	1	101	0	0.0093	0.0000	8	10
9	10	91	1	90	0	0.0110	0.0000	9	10
11	10	3	0	3	0	0.0000	0.0000	11	10
1	11	154	27	127	24	0.1753	0.1890	1	11
2	11	37	1	36	2	0.0270	0.0556	2	11
3	11	88	0	88	3	0.0000	0.0341	3	11
4	11	75	3	72	0	0.0400	0.0000	4	11
5	11	30	1	29	1	0.0333	0.0345	5	11
6	11	25	1	24	2	0.0400	0.0833	6	11
8	11	11	0	11	0	0.0000	0.0000	8	11
9	11	40	0	40	0	0.0000	0.0000	9	11
10	11	29	2	27	0	0.0690	0.0000	10	11

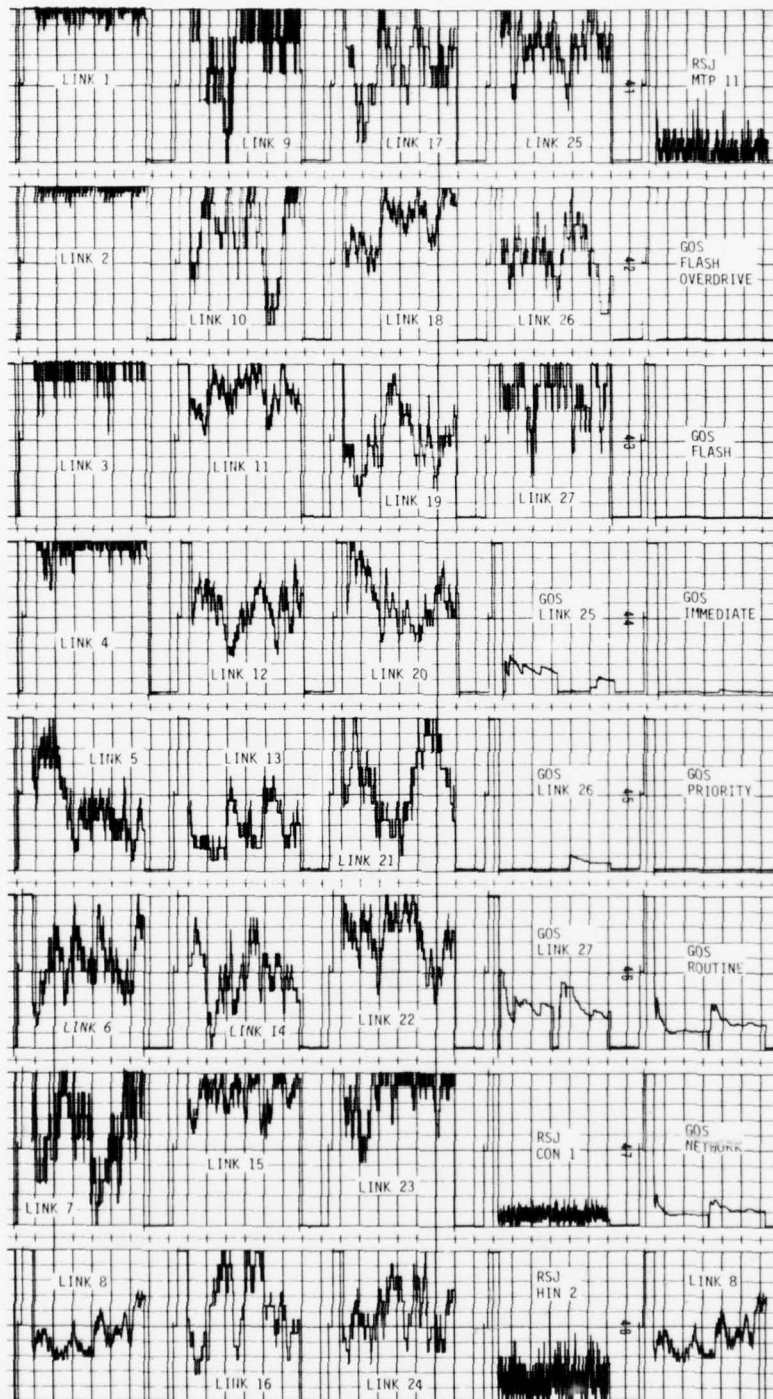

Stripplot Data for Baseline Scenario SC1100 from 30 to 60 Minutes

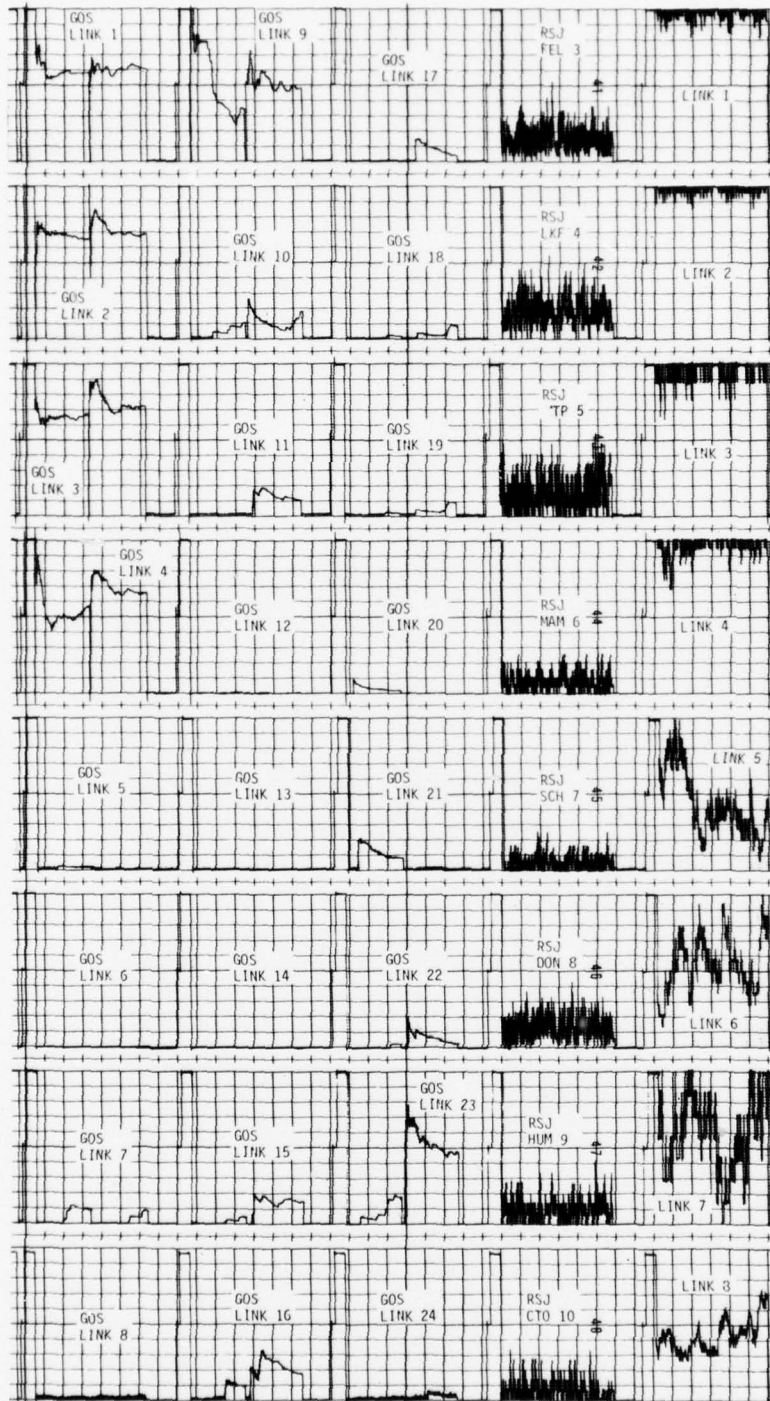

Stripplot Data for Baseline Scenario SC1100 from 30 to 60 Minutes

THIS PAGE IS BEST QUALITY PRACTICABLE
 FROM COPY FURNISHED TO DDC

SECTION II

DIGITAL DISPLAY DATA AND STRIPCHART RECORDINGS FOR BASELINE SCENARIO SC1300

***** 0:45: 0*****

ACCUMULATED TOTAL NETWORK STATISTICS
 ATTEMPTS BLOCKS COMPLETE PREEMPTED BL/ATT PR/COM
 1088 9 1079 11 0.0083 0.0102

***** 0:45: 0*****

ACCUMULATED NETWORK PRECEDENCE STATISTICS
 PREC ATTEMPTS BLOCKS COMPLETE PREEMPTED BL/ATT PR/COM PREC
 0 0 0 0 0 0.0000 0.0000 0
 1 2 0 2 0 0.0000 0.0000 1
 2 293 0 293 0 0.0000 0.0000 2
 3 68 0 68 0 0.0000 0.0000 3
 4 725 9 716 11 0.0124 0.0154 4

***** 0:45: 0*****

*ACCUMULATED LINK/PRIORITY GOS STATUS

LINK A	TOTAL	P0	P1	P2	P3	P4
	BLCK/ATTM=X,XX	BLCK/ATTM	BLCK/ATTM	BLCK/ATTM	BLCK/ATTM	BLCK/ATTM
1	61/ 213=0.29	0/ 0	0/ 0	35/ 121	0/ 0	26/ 92
2 *	80/ 227=0.35	0/ 0	0/ 1	46/ 130	0/ 0	34/ 96
3 *	37/ 88=0.42	0/ 0	1/ 1	24/ 58	0/ 0	12/ 29
4	14/ 109=0.13	0/ 0	0/ 0	6/ 55	0/ 0	8/ 54
5	0/ 34=0.00	0/ 0	0/ 0	0/ 15	0/ 0	0/ 19
6	0/ 38=0.00	0/ 0	0/ 0	0/ 18	0/ 2	0/ 18
7	0/ 18=0.00	0/ 0	0/ 0	0/ 10	0/ 0	0/ 8
8	0/ 80=0.00	0/ 0	0/ 0	0/ 27	0/ 10	0/ 43
9	0/ 13=0.00	0/ 0	0/ 0	0/ 1	0/ 2	0/ 10
10	4/ 44=0.09	0/ 0	0/ 0	0/ 19	1/ 3	3/ 22
11	7/ 133=0.05	0/ 0	0/ 0	5/ 42	1/ 6	1/ 85
12	0/ 41=0.00	0/ 0	0/ 0	0/ 16	0/ 1	0/ 24
13	0/ 27=0.00	0/ 0	0/ 0	0/ 11	0/ 3	0/ 13
14	0/ 44=0.00	0/ 0	0/ 0	0/ 14	0/ 3	0/ 27
15	1/ 134=0.01	0/ 0	0/ 1	0/ 11	0/ 14	1/ 108
16	0/ 39=0.00	0/ 0	0/ 1	0/ 3	0/ 4	0/ 31
17	0/ 23=0.00	0/ 0	0/ 0	0/ 2	0/ 4	0/ 17
18	0/ 135=0.00	0/ 0	0/ 0	0/ 12	0/ 13	0/ 110
19	0/ 37=0.00	0/ 0	0/ 0	0/ 1	0/ 3	0/ 33
20	0/ 35=0.00	0/ 0	0/ 0	0/ 5	0/ 3	0/ 27
21	0/ 28=0.00	0/ 0	0/ 1	0/ 4	0/ 2	0/ 21
22	9/ 63=0.14	0/ 0	0/ 0	3/ 27	0/ 2	6/ 34
23	11/ 61=0.18	0/ 0	0/ 0	2/ 9	3/ 7	6/ 45
24	4/ 42=0.10	0/ 0	0/ 0	0/ 3	1/ 4	3/ 35
25	0/ 45=0.00	0/ 0	0/ 0	0/ 3	0/ 7	0/ 35
26	0/ 36=0.00	0/ 0	0/ 0	0/ 2	0/ 2	0/ 32
27	6/ 46=0.13	0/ 0	0/ 0	0/ 3	1/ 4	5/ 39

***** 0:45: 0*****

ACCUMULATED SOURCE NODE NETWORK STATISTICS

NODE	ATTEMPTS	BLOCKS	COMPLETE	PREEMPTED	BL/ATT	PR/COM	NODE
1	141	2	139	1	0.0142	0.0072	1
2	95	2	93	2	0.0211	0.0215	2
3	173	2	171	1	0.0116	0.0058	3
4	156	0	156	1	0.0000	0.0064	4
5	64	0	64	0	0.0000	0.0000	5
6	67	0	67	1	0.0000	0.0149	6
7	46	0	46	0	0.0000	0.0000	7
8	141	2	139	1	0.0142	0.0072	8
9	78	0	78	1	0.0000	0.0128	9
10	63	0	63	1	0.0000	0.0159	10
11	64	1	63	2	0.0156	0.0317	11

THIS PAGE IS BEST QUALITY PRACTICABLE
 FROM COPY FURNISHED TO DDC

***** 0:45: 0*****

ACCUMULATED NODE TO NODE NETWORK STATISTICS

NODE	NODE	ATTEMPTS	BLOCKS	COMPLETE	PREEMPTED	BL/ATT	PR/COM	NODE	NODE
2	1	48	2	46	2	0.0417	0.0435	2	1
3	1	44	2	42	1	0.0455	0.0238	3	1
4	1	51	0	51	1	0.0000	0.0196	4	1
5	1	28	0	28	0	0.0000	0.0000	5	1
6	1	25	0	25	1	0.0000	0.0400	6	1
7	1	10	0	10	0	0.0000	0.0000	7	1
8	1	49	2	47	1	0.0408	0.0213	8	1
9	1	25	0	25	1	0.0000	0.0400	9	1
10	1	3	0	3	0	0.0000	0.0000	10	1
11	1	24	0	24	1	0.0000	0.0417	11	1
1	2	17	0	17	0	0.0000	0.0000	1	2
4	2	2	0	2	0	0.0000	0.0000	4	2
6	2	1	0	1	0	0.0000	0.0000	6	2
7	2	2	0	2	0	0.0000	0.0000	7	2
9	2	5	0	5	0	0.0000	0.0000	9	2
1	3	24	0	24	0	0.0000	0.0000	1	3
2	3	1	0	1	0	0.0000	0.0000	2	3
4	3	44	0	44	0	0.0000	0.0000	4	3
5	3	3	0	3	0	0.0000	0.0000	5	3
6	3	2	0	2	0	0.0000	0.0000	6	3
7	3	6	0	6	0	0.0000	0.0000	7	3
8	3	35	0	35	0	0.0000	0.0000	8	3
9	3	3	0	3	0	0.0000	0.0000	9	3
10	3	22	0	22	0	0.0000	0.0000	10	3
11	3	16	0	16	0	0.0000	0.0000	11	3
1	4	21	0	21	0	0.0000	0.0000	1	4
2	4	5	0	5	0	0.0000	0.0000	2	4
3	4	24	0	24	0	0.0000	0.0000	3	4
5	4	10	0	10	0	0.0000	0.0000	5	4
6	4	11	0	11	0	0.0000	0.0000	6	4
7	4	10	0	10	0	0.0000	0.0000	7	4
8	4	29	0	29	0	0.0000	0.0000	8	4
9	4	11	0	11	0	0.0000	0.0000	9	4
10	4	6	0	6	0	0.0000	0.0000	10	4
11	4	5	0	5	0	0.0000	0.0000	11	4
1	5	8	0	8	1	0.0000	0.1250	1	5
3	5	2	0	2	0	0.0000	0.0000	3	5
4	5	2	0	2	0	0.0000	0.0000	4	5
8	5	7	0	7	0	0.0000	0.0000	8	5
9	5	7	0	7	0	0.0000	0.0000	9	5
10	5	3	0	3	0	0.0000	0.0000	10	5
11	5	3	1	2	1	0.3333	0.5000	11	5
1	6	20	1	19	0	0.0500	0.0000	1	6
2	6	30	0	30	0	0.0000	0.0000	2	6
3	6	3	0	3	0	0.0000	0.0000	3	6
4	6	7	0	7	0	0.0000	0.0000	4	6
7	6	3	0	3	0	0.0000	0.0000	7	6
8	6	8	0	8	0	0.0000	0.0000	8	6
9	6	3	0	3	0	0.0000	0.0000	9	6

THIS PAGE IS BEST QUALITY PRACTICABLE
 FROM COPY FURNISHED TO DDC

1	7	6	0	6	0	0.0000	0.0000	1	7
2	7	1	0	1	0	0.0000	0.0000	2	7
3	7	21	0	21	0	0.0000	0.0000	3	7
4	7	8	0	8	0	0.0000	0.0000	4	7
5	7	1	0	1	0	0.0000	0.0000	5	7
6	7	2	0	2	0	0.0000	0.0000	6	7
8	7	7	0	7	0	0.0000	0.0000	8	7
9	7	5	0	5	0	0.0000	0.0000	9	7
10	7	3	0	3	0	0.0000	0.0000	10	7
11	7	1	0	1	0	0.0000	0.0000	11	7
1	8	25	0	25	0	0.0000	0.0000	1	8
2	8	9	0	9	0	0.0000	0.0000	2	8
3	8	60	0	60	0	0.0000	0.0000	3	8
4	8	21	0	21	0	0.0000	0.0000	4	8
5	8	13	0	13	0	0.0000	0.0000	5	8
6	8	20	0	20	0	0.0000	0.0000	6	8
7	8	12	0	12	0	0.0000	0.0000	7	8
9	8	12	0	12	0	0.0000	0.0000	9	8
10	8	14	0	14	0	0.0000	0.0000	10	8
11	8	13	0	13	0	0.0000	0.0000	11	8
1	9	12	1	11	0	0.0833	0.0000	1	9
3	9	1	0	1	0	0.0000	0.0000	3	9
4	9	8	0	8	0	0.0000	0.0000	4	9
5	9	2	0	2	0	0.0000	0.0000	5	9
6	9	2	0	2	0	0.0000	0.0000	6	9
7	9	3	0	3	0	0.0000	0.0000	7	9
8	9	1	0	1	0	0.0000	0.0000	8	9
10	9	8	0	8	0	0.0000	0.0000	10	9
11	9	2	0	2	0	0.0000	0.0000	11	9
3	10	14	0	14	0	0.0000	0.0000	3	10
4	10	6	0	6	0	0.0000	0.0000	4	10
5	10	4	0	4	0	0.0000	0.0000	5	10
6	10	4	0	4	0	0.0000	0.0000	6	10
8	10	4	0	4	0	0.0000	0.0000	8	10
9	10	5	0	5	0	0.0000	0.0000	9	10
1	11	8	0	8	0	0.0000	0.0000	1	11
2	11	1	0	1	0	0.0000	0.0000	2	11
3	11	4	0	4	0	0.0000	0.0000	3	11
4	11	7	0	7	0	0.0000	0.0000	4	11
5	11	3	0	3	0	0.0000	0.0000	5	11
8	11	1	0	1	0	0.0000	0.0000	8	11
9	11	2	0	2	0	0.0000	0.0000	9	11
10	11	4	0	4	1	0.0000	0.2500	10	11

THIS PAGE IS BEST QUALITY PRACTICABLE
FROM COPY FURNISHED TO DDC

***** 1: 0: 0*****
ACCUMULATED TOTAL NETWORK STATISTICS
ATTEMPTS BLOCKS COMPLETE PREEMPTED BL/ATT PR/COM
1322 144 1178 87 0.1089 0.0739

***** 1: 0: 0*****
ACCUMULATED NETWORK PRECEDENCE STATISTICS
PREC ATTEMPTS BLOCKS COMPLETE PREEMPTED BL/ATT PR/COM PREC
0 0 0 0 0 0.0000 0.0000 0
1 2 0 2 0 0.0000 0.0000 1
2 313 0 313 0 0.0000 0.0000 2
3 81 0 81 0 0.0000 0.0000 3
4 926 144 782 87 0.1555 0.1113 4

***** 1: 0: 0*****
*ACCUMULATED LINK/PRIORITY GOS STATUS

LINK A	TOTAL	P0		P1		P2		P3		P4
	BLCK/ATTM=X.XX	BLCK/ATTM	BLCK/ATTM	BLCK/ATTM	BLCK/ATTM	BLCK/ATTM	BLCK/ATTM	BLCK/ATTM	BLCK/ATTM	BLCK/ATTM
1**	276/ 419=0.66	0/ 0	2/ 2	110/ 182	0/ 0	164/ 235				
2**	323/ 523=0.62	0/ 0	2/ 3	127/ 230	0/ 0	194/ 290				
3**	124/ 179=0.69	0/ 0	0/ 0	50/ 79	0/ 0	74/ 100				
4**	187/ 305=0.61	0/ 0	1/ 2	72/ 136	0/ 0	114/ 167				
5	0/ 85=0.00	0/ 0	0/ 2	0/ 35	0/ 1	0/ 47				
6	0/ 81=0.00	0/ 0	0/ 0	0/ 25	0/ 2	0/ 54				
7	7/ 84=0.08	0/ 0	0/ 0	3/ 31	0/ 1	4/ 52				
8	0/ 100=0.00	0/ 0	0/ 0	0/ 18	0/ 9	0/ 73				
9**	54/ 86=0.63	0/ 0	0/ 0	16/ 24	3/ 6	35/ 56				
10	5/ 63=0.08	0/ 0	0/ 0	1/ 23	0/ 4	4/ 36				
11	3/ 199=0.02	0/ 0	0/ 0	0/ 67	0/ 4	3/ 128				
12	0/ 99=0.00	0/ 0	0/ 0	0/ 24	0/ 4	0/ 71				
13	0/ 45=0.00	0/ 0	0/ 0	0/ 9	0/ 3	0/ 33				
14	0/ 46=0.00	0/ 0	0/ 0	0/ 14	0/ 5	0/ 27				
15	12/ 219=0.05	0/ 0	0/ 2	7/ 52	0/ 13	5/ 152				
16	0/ 32=0.00	0/ 0	0/ 0	0/ 2	0/ 4	0/ 26				
17	0/ 20=0.00	0/ 0	0/ 0	0/ 0	0/ 5	0/ 15				
18	1/ 191=0.01	0/ 0	0/ 0	0/ 31	0/ 16	1/ 144				
19	0/ 40=0.00	0/ 0	0/ 0	0/ 2	0/ 4	0/ 34				
20	0/ 51=0.00	0/ 0	0/ 0	0/ 10	0/ 1	0/ 40				
21	0/ 31=0.00	0/ 0	0/ 0	0/ 3	0/ 2	0/ 26				
22	4/ 91=0.04	0/ 0	0/ 0	1/ 18	0/ 6	3/ 67				
23	26/ 87=0.30	0/ 0	0/ 0	2/ 6	3/ 9	21/ 72				
24	9/ 52=0.17	0/ 0	0/ 0	2/ 10	1/ 3	6/ 39				
25	0/ 46=0.00	0/ 0	0/ 0	0/ 5	0/ 5	0/ 36				
26	0/ 35=0.00	0/ 0	0/ 0	0/ 3	0/ 3	0/ 29				
27	7/ 40=0.18	0/ 0	0/ 0	1/ 5	1/ 4	5/ 31				

***** 1: 0: 0*****
ACCUMULATED SOURCE NODE NETWORK STATISTICS
ATTEMPTS BLOCKS COMPLETE PREEMPTED BL/ATT PR/COM NODE

NODE	ATTEMPTS	BLOCKS	COMPLETE	PREEMPTED	BL/ATT	PR/COM	NODE
1	185	29	156	25	0.1568	0.1603	1
2	107	10	97	10	0.0935	0.1031	2
3	189	9	180	9	0.0476	0.0500	3
4	183	26	157	12	0.1421	0.0764	4
5	73	8	65	3	0.1096	0.0462	5
6	94	7	87	4	0.0745	0.0460	6
7	62	3	59	0	0.0484	0.0000	7
8	201	32	169	14	0.1592	0.0828	8
9	84	4	80	6	0.0476	0.0750	9
10	55	0	55	1	0.0000	0.0182	10
11	89	16	73	3	0.1798	0.0411	11

THIS PAGE IS BEST QUALITY PRACTICABLE
 FROM COPY FURNISHED TO DDC

***** 1: 0: 0*****

ACCUMULATED NODE TO NODE NETWORK STATISTICS

NODE	NODE	ATTEMPTS	BLOCKS	COMPLETE	PREEMPTED	BL/ATT	PR/COM	NODE	NODE
2	1	59	10	49	10	0.1695	0.2041	2	1
3	1	64	9	55	9	0.1406	0.1636	3	1
4	1	88	26	62	12	0.2955	0.1935	4	1
5	1	31	8	23	3	0.2581	0.1304	5	1
6	1	33	7	26	4	0.2121	0.1538	6	1
7	1	12	3	9	0	0.2500	0.0000	7	1
8	1	111	32	79	14	0.2883	0.1772	8	1
9	1	31	4	27	5	0.1290	0.1852	9	1
10	1	4	0	4	1	0.0000	0.2500	10	1
11	1	38	15	23	3	0.3947	0.1304	11	1
1	2	30	3	27	5	0.1000	0.1852	1	2
4	2	3	0	3	0	0.0000	0.0000	4	2
6	2	5	0	5	0	0.0000	0.0000	6	2
8	2	3	0	3	0	0.0000	0.0000	8	2
9	2	6	0	6	0	0.0000	0.0000	9	2
11	2	4	0	4	0	0.0000	0.0000	11	2
1	3	29	9	20	4	0.3103	0.2000	1	3
2	3	1	0	1	0	0.0000	0.0000	2	3
4	3	38	0	38	0	0.0000	0.0000	4	3
5	3	6	0	6	0	0.0000	0.0000	5	3
6	3	2	0	2	0	0.0000	0.0000	6	3
7	3	5	0	5	0	0.0000	0.0000	7	3
8	3	28	0	28	0	0.0000	0.0000	8	3
9	3	4	0	4	0	0.0000	0.0000	9	3
10	3	17	0	17	0	0.0000	0.0000	10	3
11	3	12	0	12	0	0.0000	0.0000	11	3
1	4	34	5	29	3	0.1471	0.1034	1	4
2	4	4	0	4	0	0.0000	0.0000	2	4
3	4	30	0	30	0	0.0000	0.0000	3	4
5	4	6	0	6	0	0.0000	0.0000	5	4
6	4	14	0	14	0	0.0000	0.0000	6	4
7	4	14	0	14	0	0.0000	0.0000	7	4
8	4	30	0	30	0	0.0000	0.0000	8	4
9	4	9	0	9	0	0.0000	0.0000	9	4
10	4	9	0	9	0	0.0000	0.0000	10	4
11	4	11	1	10	0	0.0909	0.0000	11	4
1	5	15	2	13	2	0.1333	0.1538	1	5
2	5	1	0	1	0	0.0000	0.0000	2	5
3	5	2	0	2	0	0.0000	0.0000	3	5
4	5	4	0	4	0	0.0000	0.0000	4	5
8	5	6	0	6	0	0.0000	0.0000	8	5
9	5	8	0	8	0	0.0000	0.0000	9	5
10	5	6	0	6	0	0.0000	0.0000	10	5
11	5	5	0	5	0	0.0000	0.0000	11	5
1	6	10	2	8	3	0.2000	0.3750	1	6
2	6	23	0	23	0	0.0000	0.0000	2	6
3	6	5	0	5	0	0.0000	0.0000	3	6
4	6	11	0	11	0	0.0000	0.0000	4	6
5	6	1	0	1	0	0.0000	0.0000	5	6
7	6	3	0	3	0	0.0000	0.0000	7	6
8	6	5	0	5	0	0.0000	0.0000	8	6
9	6	7	0	7	0	0.0000	0.0000	9	6
11	6	1	0	1	0	0.0000	0.0000	11	6

THIS PAGE IS BEST QUALITY PRACTICABLE
 FROM COPY FURNISHED TO DDC

1	7	9	3	6	0 0.3333	0.0000	1	7
3	7	19	0	19	0 0.0000	0.0000	3	7
4	7	4	0	4	0 0.0000	0.0000	4	7
5	7	2	0	2	0 0.0000	0.0000	5	7
8	7	4	0	4	0 0.0000	0.0000	8	7
9	7	3	0	3	0 0.0000	0.0000	9	7
10	7	1	0	1	0 0.0000	0.0000	10	7
11	7	1	0	1	0 0.0000	0.0000	11	7
1	8	29	3	26	5 0.1034	0.1923	1	8
2	8	18	0	18	0 0.0000	0.0000	2	8
3	8	50	0	50	0 0.0000	0.0000	3	8
4	8	24	0	24	0 0.0000	0.0000	4	8
5	8	13	0	13	0 0.0000	0.0000	5	8
6	8	30	0	30	0 0.0000	0.0000	6	8
7	8	21	0	21	0 0.0000	0.0000	7	8
9	8	11	0	11	0 0.0000	0.0000	9	8
10	8	11	0	11	0 0.0000	0.0000	10	8
11	8	10	0	10	0 0.0000	0.0000	11	8
1	9	16	1	15	0 0.0625	0.0000	1	9
4	9	6	0	6	0 0.0000	0.0000	4	9
5	9	2	0	2	0 0.0000	0.0000	5	9
6	9	9	0	9	0 0.0000	0.0000	6	9
7	9	4	0	4	0 0.0000	0.0000	7	9
8	9	5	0	5	0 0.0000	0.0000	8	9
10	9	3	0	3	0 0.0000	0.0000	10	9
11	9	7	0	7	0 0.0000	0.0000	11	9
1	10	3	0	3	1 0.0000	0.3333	1	10
3	10	11	0	11	0 0.0000	0.0000	3	10
4	10	2	0	2	0 0.0000	0.0000	4	10
5	10	7	0	7	0 0.0000	0.0000	5	10
6	10	1	0	1	0 0.0000	0.0000	6	10
7	10	3	0	3	0 0.0000	0.0000	7	10
8	10	7	0	7	0 0.0000	0.0000	8	10
9	10	4	0	4	0 0.0000	0.0000	9	10
1	11	10	1	9	2 0.1000	0.2222	1	11
2	11	1	0	1	0 0.0000	0.0000	2	11
3	11	8	0	8	0 0.0000	0.0000	3	11
4	11	3	0	3	0 0.0000	0.0000	4	11
5	11	5	0	5	0 0.0000	0.0000	5	11
8	11	2	0	2	0 0.0000	0.0000	8	11
9	11	1	0	1	1 0.0000	1.0000	9	11
10	11	4	0	4	0 0.0000	0.0000	10	11

THIS PAGE IS BEST QUALITY PRACTICABLE
 FROM COPY FURNISHED TO DDC

***** 4: 0: 0*****

ACCUMULATED TOTAL NETWORK STATISTICS
 ATTEMPTS BLOCKS COMPLETE PREEMPTED BL/ATT PR/COM
 19929 1837 18092 989 0.0922 0.0547

***** 4: 0: 0*****

ACCUMULATED NETWORK PRECEDENCE STATISTICS

PREC	ATTEMPTS	BLOCKS	COMPLETE	PREEMPTED	BL/ATT	PR/COM	PREC
0	1	0	1	0	0.0000	0.0000	0
1	37	0	37	0	0.0000	0.0000	1
2	4680	0	4680	1	0.0000	0.0002	2
3	1202	0	1202	0	0.0000	0.0000	3
4	14009	1837	12172	988	0.1311	0.0812	4

***** 4: 0: 0*****

*ACCUMULATED LINK/PRIORITY GOS STATUS

LINK A	TOTAL	P0	P1	P2	P3	P4
	BLCK/ATTM=X.XX	BLCK/ATTM	BLCK/ATTM	BLCK/ATTM	BLCK/ATTM	BLCK/ATTM
1**	3467/5864=0.59	0/ 1	13/ 17	1452/2675	0/ 0	2002/3171
2**	4125/6792=0.61	2/ 2	14/ 23	1726/3114	0/ 0	2383/3653
3**	1699/2541=0.67	1/ 1	5/ 8	738/1219	0/ 0	955/1313
4**	1910/3609=0.53	1/ 1	6/ 20	750/1625	0/ 0	1153/1963
5	1/1307=0.00	0/ 0	0/ 4	1/ 546	0/ 2	0/ 755
6	16/1148=0.01	0/ 0	0/ 1	7/ 399	0/ 40	9/ 708
7	183/1201=0.15	0/ 0	0/ 1	67/ 448	0/ 14	116/ 738
8	0/1431=0.00	0/ 0	0/ 3	0/ 347	0/ 111	0/ 970
9 *	465/ 949=0.49	0/ 1	2/ 4	122/ 233	13/ 35	328/ 676
10	66/ 914=0.07	0/ 0	0/ 1	19/ 314	6/ 35	41/ 564
11	247/3028=0.08	0/ 0	1/ 1	48/ 863	13/ 142	185/2022
12	0/1432=0.00	0/ 0	0/ 3	0/ 472	0/ 38	0/ 919
13	2/ 561=0.00	0/ 0	0/ 1	0/ 123	0/ 34	2/ 403
14	0/ 634=0.00	0/ 0	0/ 1	0/ 131	0/ 54	0/ 448
15	389/3177=0.12	0/ 1	1/ 8	90/ 662	18/ 200	280/2306
16	57/ 687=0.08	0/ 1	0/ 1	6/ 70	7/ 69	44/ 546
17	7/ 359=0.02	0/ 0	0/ 0	1/ 28	1/ 56	5/ 275
18	148/2859=0.05	0/ 0	0/ 5	20/ 404	7/ 247	121/2203
19	8/ 670=0.01	0/ 0	0/ 1	1/ 44	1/ 65	6/ 560
20	8/ 887=0.01	0/ 0	0/ 3	1/ 181	2/ 72	5/ 631
21	21/ 501=0.04	0/ 1	0/ 2	7/ 86	0/ 41	14/ 371
22	93/1261=0.07	0/ 0	0/ 2	17/ 314	3/ 71	73/ 874
23	421/1441=0.29	0/ 0	1/ 2	52/ 162	40/ 144	328/1133
24	54/ 773=0.07	0/ 0	0/ 0	7/ 82	6/ 64	41/ 627
25	108/ 870=0.12	0/ 0	0/ 0	12/ 79	11/ 101	85/ 690
26	78/ 787=0.10	0/ 1	0/ 0	6/ 80	8/ 81	64/ 625
27	164/ 656=0.25	0/ 0	0/ 0	6/ 42	19/ 70	139/ 544

***** 4: 0: 0*****

ACCUMULATED SOURCE NODE NETWORK STATISTICS

NODE	ATTEMPTS	BLOCKS	COMPLETE	PREEMPTED	BL/ATT	PR/COM	NODE
1	2784	372	2412	256	0.1336	0.1061	1
2	1632	202	1430	123	0.1238	0.0860	2
3	2906	176	2730	105	0.0606	0.0385	3
4	2942	271	2671	133	0.0921	0.0498	4
5	1059	112	947	64	0.1058	0.0676	5
6	1383	104	1279	40	0.0752	0.0313	6
7	786	27	759	8	0.0344	0.0105	7
8	2833	304	2529	131	0.1073	0.0518	8
9	1330	78	1252	53	0.0586	0.0423	9
10	1077	44	1033	15	0.0409	0.0145	10
11	1197	147	1050	61	0.1228	0.0581	11

*INPUT DATA*968

*****DATA INPUT 968 0 0 0 0 0 0*****

***** 4: 0: 0*****

ACCUMULATED NODE TO NODE NETWORK STATISTICS

NODE	NODE	ATTEMPTS	BLOCKS	COMPLETE	PREEMPTED	BL/ATT	PR/COM	NODE	NODE
2	1	911	186	725	122	0.2042	0.1683	2	1
3	1	908	136	772	94	0.1498	0.1218	3	1
4	1	1169	241	928	125	0.2062	0.1347	4	1
5	1	478	110	368	64	0.2301	0.1739	5	1
6	1	429	81	348	37	0.1888	0.1063	6	1
7	1	158	25	133	8	0.1582	0.0602	7	1
8	1	1287	274	1013	124	0.2129	0.1224	8	1
9	1	459	74	385	49	0.1612	0.1273	9	1
10	1	103	10	93	9	0.0971	0.0968	10	1
11	1	488	129	359	48	0.2643	0.1337	11	1
1	2	445	71	374	39	0.1596	0.1043	1	2
3	2	3	0	3	0	0.0000	0.0000	3	2
4	2	51	0	51	0	0.0000	0.0000	4	2
5	2	1	0	1	0	0.0000	0.0000	5	2
6	2	59	0	59	0	0.0000	0.0000	6	2
7	2	10	0	10	0	0.0000	0.0000	7	2
8	2	46	1	45	1	0.0217	0.0222	8	2
9	2	53	0	53	0	0.0000	0.0000	9	2
10	2	4	0	4	0	0.0000	0.0000	10	2
11	2	51	1	50	0	0.0196	0.0000	11	2
1	3	463	53	410	32	0.1145	0.0780	1	3
2	3	5	0	5	0	0.0000	0.0000	2	3
4	3	668	19	649	7	0.0284	0.0108	4	3
5	3	84	0	84	0	0.0000	0.0000	5	3
6	3	36	0	36	0	0.0000	0.0000	6	3
7	3	100	0	100	0	0.0000	0.0000	7	3
8	3	522	19	503	2	0.0364	0.0040	8	3
9	3	76	0	76	0	0.0000	0.0000	9	3
10	3	341	9	332	1	0.0264	0.0030	10	3
11	3	223	7	216	2	0.0314	0.0093	11	3
1	4	505	60	445	52	0.1188	0.1169	1	4
2	4	74	0	74	0	0.0000	0.0000	2	4
3	4	542	12	530	4	0.0221	0.0075	3	4
5	4	122	1	121	0	0.0082	0.0000	5	4
6	4	174	0	174	1	0.0000	0.0057	6	4
7	4	160	0	160	0	0.0000	0.0000	7	4
8	4	446	3	443	1	0.0067	0.0023	8	4
9	4	157	0	157	0	0.0000	0.0000	9	4
10	4	105	7	98	1	0.0667	0.0102	10	4
11	4	115	1	114	3	0.0087	0.0263	11	4
1	5	206	31	175	33	0.1505	0.1886	1	5
2	5	6	0	6	0	0.0000	0.0000	2	5
3	5	51	0	51	0	0.0000	0.0000	3	5
4	5	69	2	67	0	0.0290	0.0000	4	5
6	5	3	0	3	0	0.0000	0.0000	6	5

8	5	120	0	120	0	0.0000	0.0000	8	5
9	5	85	0	85	0	0.0000	0.0000	9	5
10	5	43	0	43	1	0.0000	0.0233	10	5
11	5	46	4	42	2	0.0870	0.0476	11	5
1	6	197	24	173	24	0.1218	0.1387	1	6
2	6	306	0	306	0	0.0000	0.0000	2	6
3	6	49	0	49	0	0.0000	0.0000	3	6
4	6	158	0	158	0	0.0000	0.0000	4	6
5	6	5	0	5	0	0.0000	0.0000	5	6
7	6	37	0	37	0	0.0000	0.0000	7	6
8	6	131	6	125	2	0.0458	0.0160	8	6
9	6	93	0	93	1	0.0000	0.0108	9	6
10	6	6	0	6	0	0.0000	0.0000	10	6
11	6	7	0	7	1	0.0000	0.1429	11	6
1	7	82	16	66	4	0.1951	0.0606	1	7
2	7	17	0	17	0	0.0000	0.0000	2	7
3	7	294	0	294	0	0.0000	0.0000	3	7
4	7	128	0	128	0	0.0000	0.0000	4	7
5	7	18	0	18	0	0.0000	0.0000	5	7
6	7	18	0	18	0	0.0000	0.0000	6	7
8	7	96	0	96	0	0.0000	0.0000	8	7
9	7	104	0	104	0	0.0000	0.0000	9	7
10	7	46	0	46	0	0.0000	0.0000	10	7
11	7	8	0	8	0	0.0000	0.0000	11	7
1	8	441	51	390	33	0.1156	0.0846	1	8
2	8	244	10	234	1	0.0410	0.0043	2	8
3	8	794	22	772	6	0.0277	0.0078	3	8
4	8	388	0	388	0	0.0000	0.0000	4	8
5	8	171	0	171	0	0.0000	0.0000	5	8
6	8	480	21	459	0	0.0437	0.0000	6	8
7	8	225	0	225	0	0.0000	0.0000	7	8
9	8	181	1	180	0	0.0055	0.0000	9	8
10	8	296	17	279	1	0.0574	0.0036	10	8
11	8	169	4	165	1	0.0237	0.0061	11	8
1	9	236	24	212	13	0.1017	0.0613	1	9
2	9	33	0	33	0	0.0000	0.0000	2	9
3	9	25	0	25	0	0.0000	0.0000	3	9
4	9	160	1	159	0	0.0063	0.0000	4	9
5	9	40	0	40	0	0.0000	0.0000	5	9
6	9	114	1	113	1	0.0088	0.0088	6	9
7	9	61	0	61	0	0.0000	0.0000	7	9
8	9	66	0	66	0	0.0000	0.0000	8	9
10	9	84	1	83	1	0.0119	0.0120	10	9
11	9	86	1	85	4	0.0116	0.0471	11	9
1	10	45	11	34	6	0.2444	0.1765	1	10
2	10	4	0	4	0	0.0000	0.0000	2	10
3	10	156	3	153	0	0.0192	0.0000	3	10
4	10	70	2	68	0	0.0286	0.0000	4	10
5	10	107	0	107	0	0.0000	0.0000	5	10
6	10	45	0	45	1	0.0000	0.0222	6	10
7	10	35	2	33	0	0.0571	0.0000	7	10
8	10	100	1	99	1	0.0100	0.0101	8	10
9	10	75	0	75	0	0.0000	0.0000	9	10
11	10	4	0	4	0	0.0000	0.0000	11	10
1	11	164	31	133	20	0.1890	0.1504	1	11
2	11	32	6	26	0	0.1875	0.0000	2	11
3	11	84	3	81	1	0.0357	0.0123	3	11
4	11	81	6	75	1	0.0741	0.0133	4	11
5	11	33	1	32	0	0.0303	0.0000	5	11
6	11	25	1	24	0	0.0400	0.0000	6	11
8	11	19	0	19	0	0.0000	0.0000	8	11
9	11	47	3	44	3	0.0638	0.0682	9	11
10	11	49	0	49	1	0.0000	0.0204	10	11

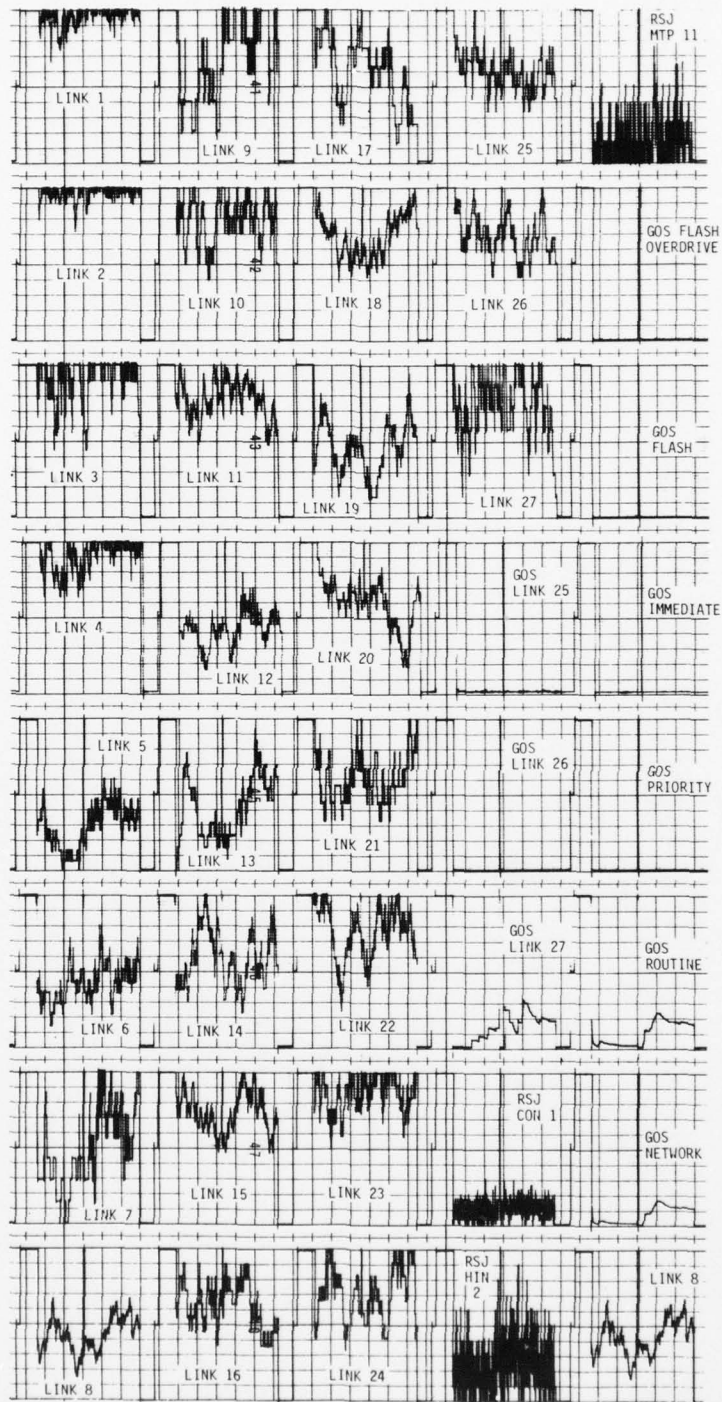

Stripplot Data for Baseline Scenario SC1300 from 30 to 60 Minutes

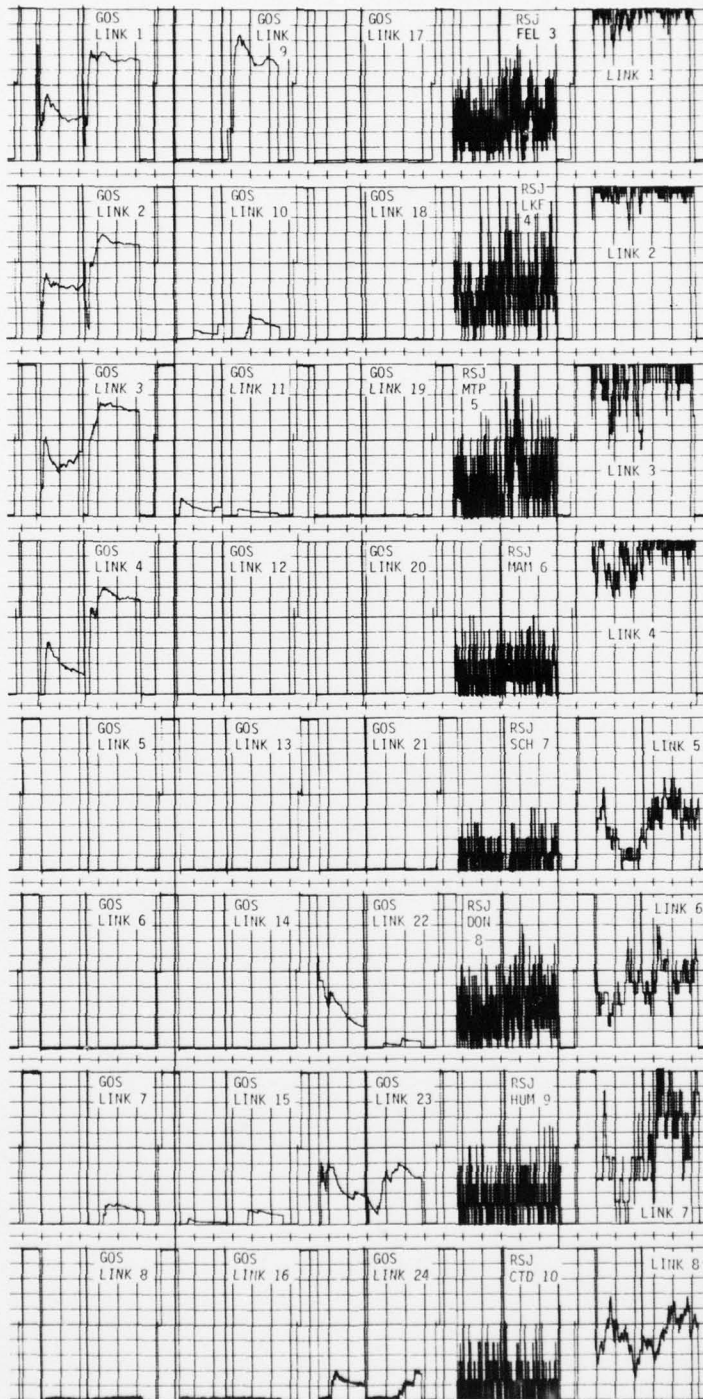

Stripplot Data for Baseline Scenario SC1300 from 30 to 60 Minutes

APPENDIX D

DRAMA QPR-QPSK HYBRID SIMULATION

ENCODER

DATE _____ SHEET 1 OF _____

BT RATE = 3730 BPS SYMBOL RATE 1865 BPS
 CARRIER = 10 KMC SCALE FACTOR "7000"



SAMPLER

DATA GENERATOR

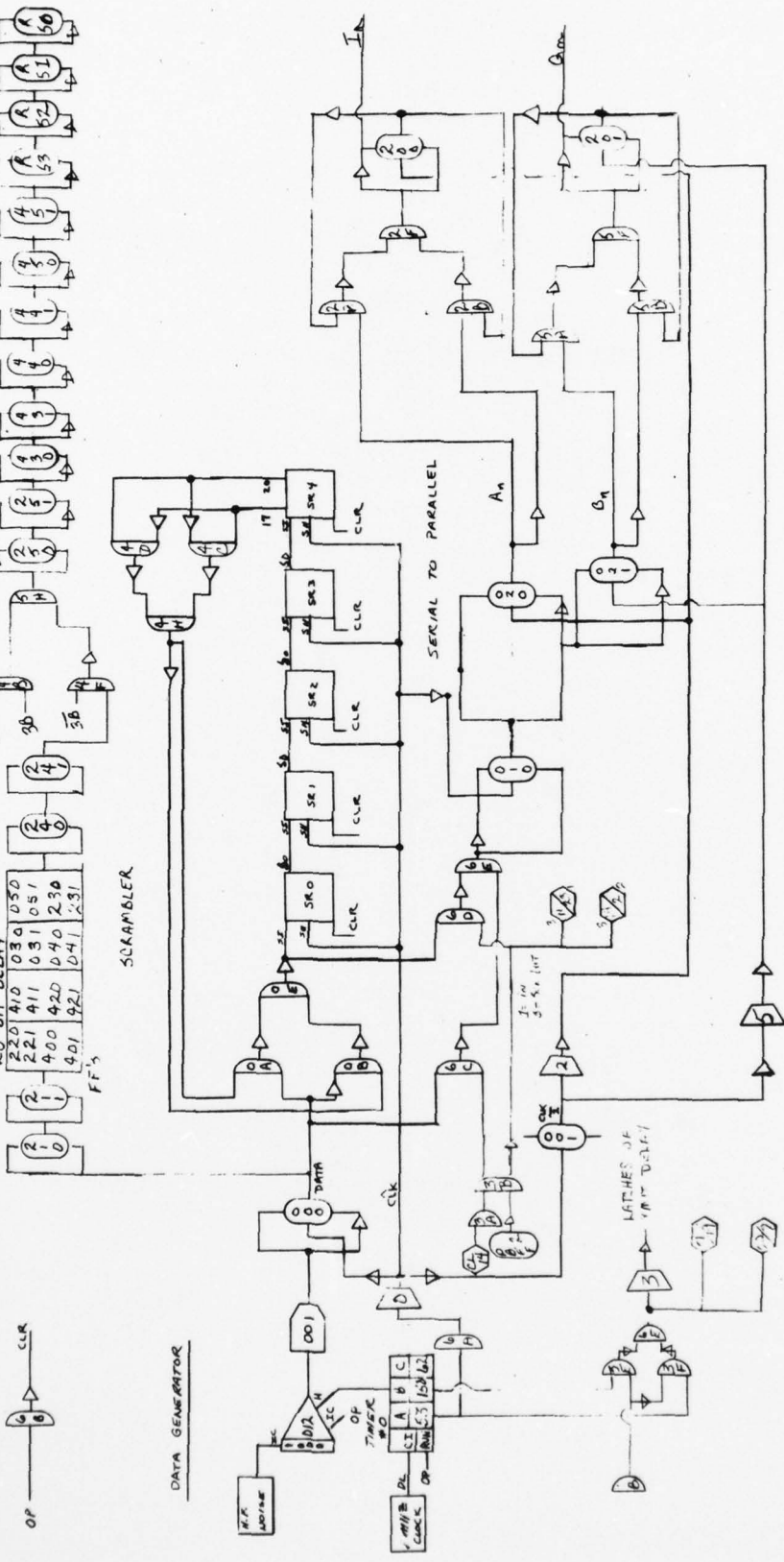

QPSK MODULATOR

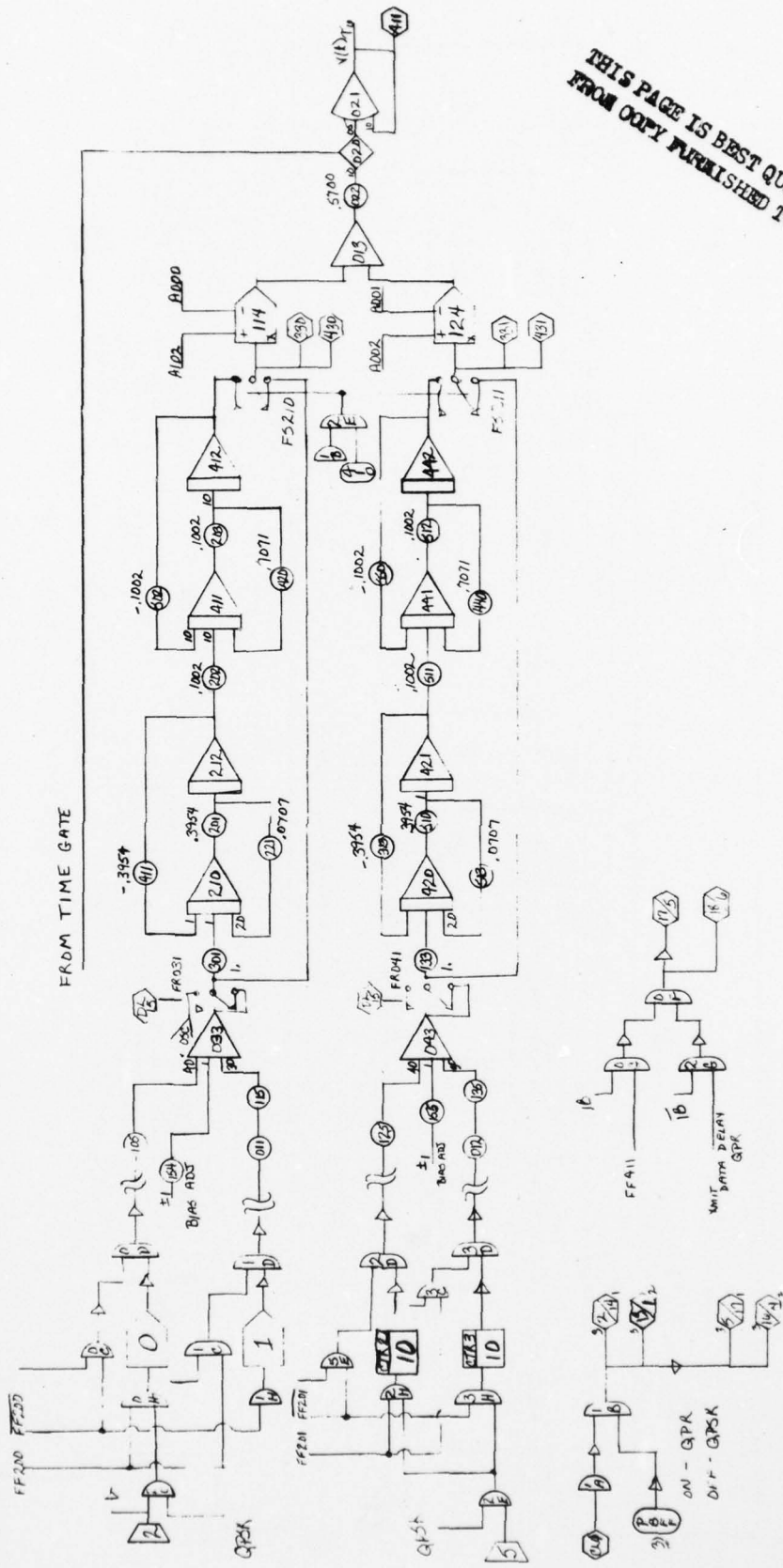

THIS PAGE IS BEST QUALITY PRACTICABLE
FROM COPY FURNISHED TO DDC

THIS PAGE IS BEST QUALITY PRACTICABLE
FROM COPY FURNISHED TO DDC

CNSL 73
DATE _____ SHEET 2 OF _____

RF FILTER NONLINEARITY
RF FILTER #1

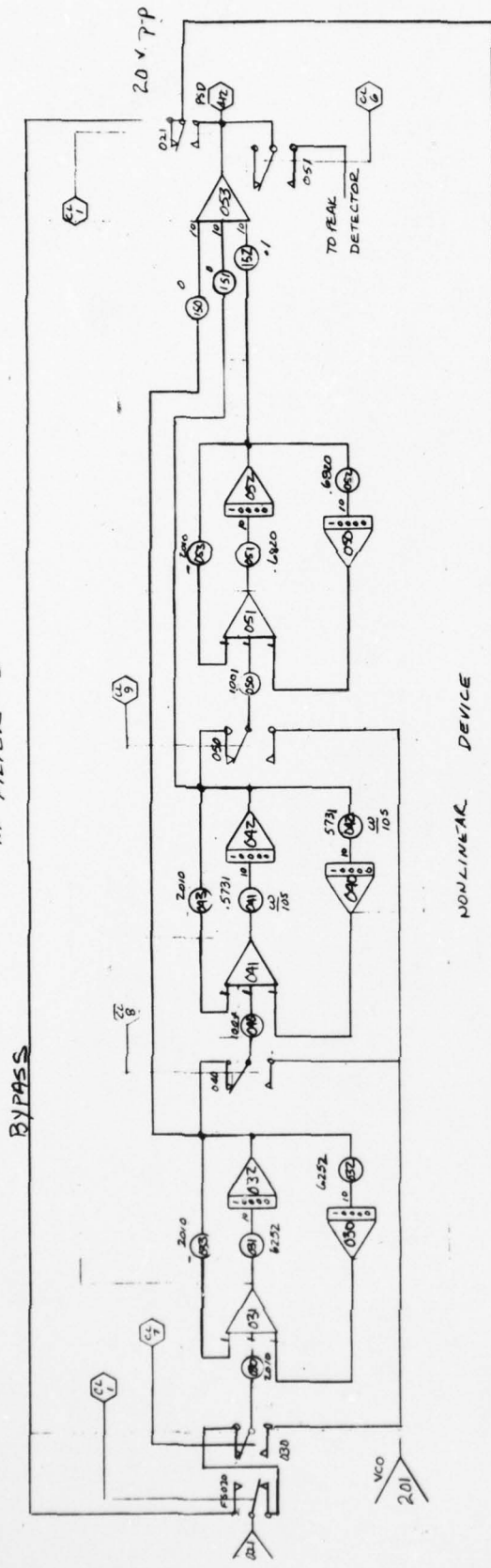

NONLINEAR DEVICE

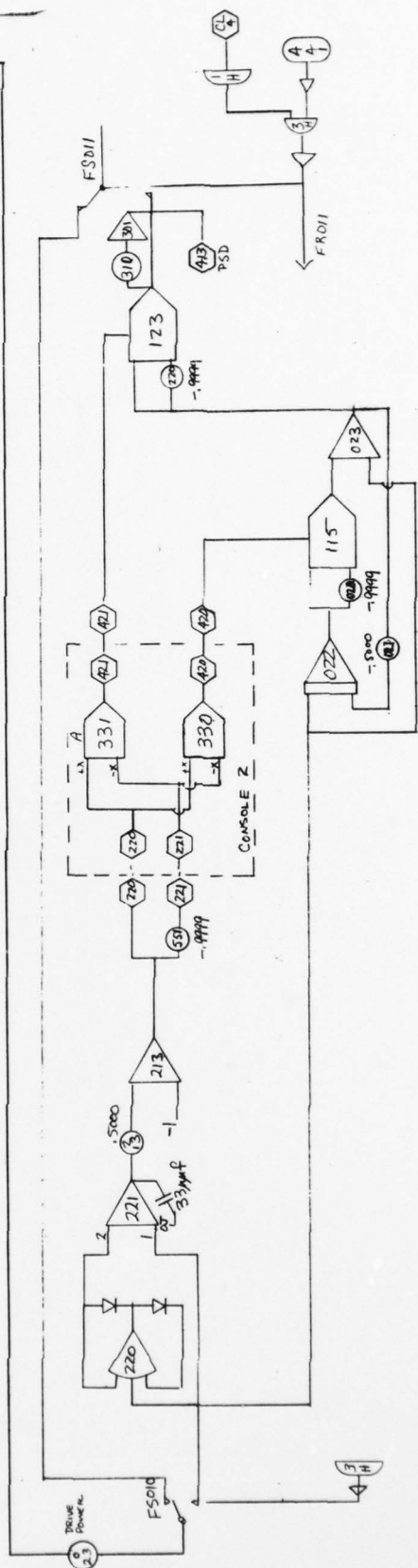

RF FILTER #2

CNSL 13

DATE _____
SHEET 3 OF _____

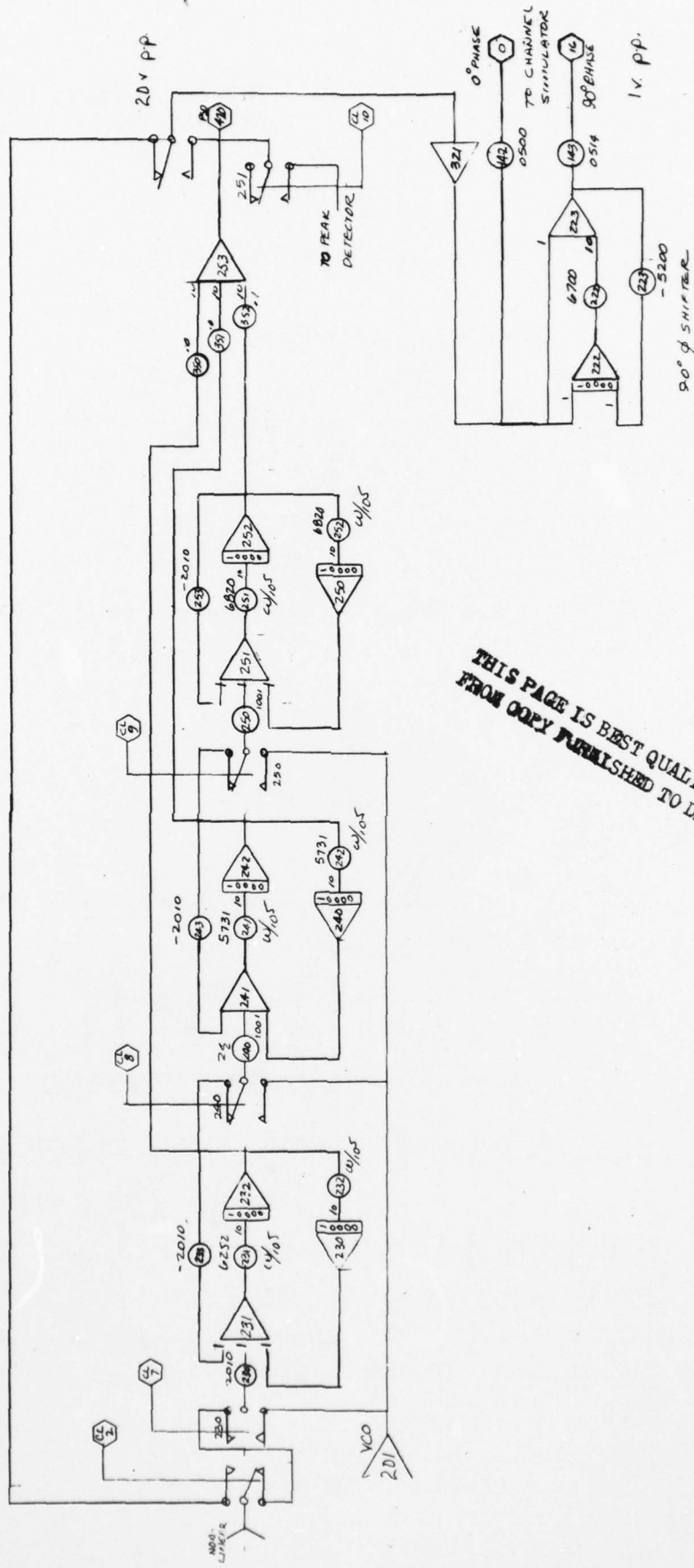

THIS PAGE IS BEST QUALITY PRACTICABLE
FROM COPY FURNISHED TO DDC

THIS PAGE IS BEST QUALITY PRACTICABLE
FROM COPY FURNISHED TO DDC

OPR-RPBL-DRAMA CHANNEL MEDIA MODEL

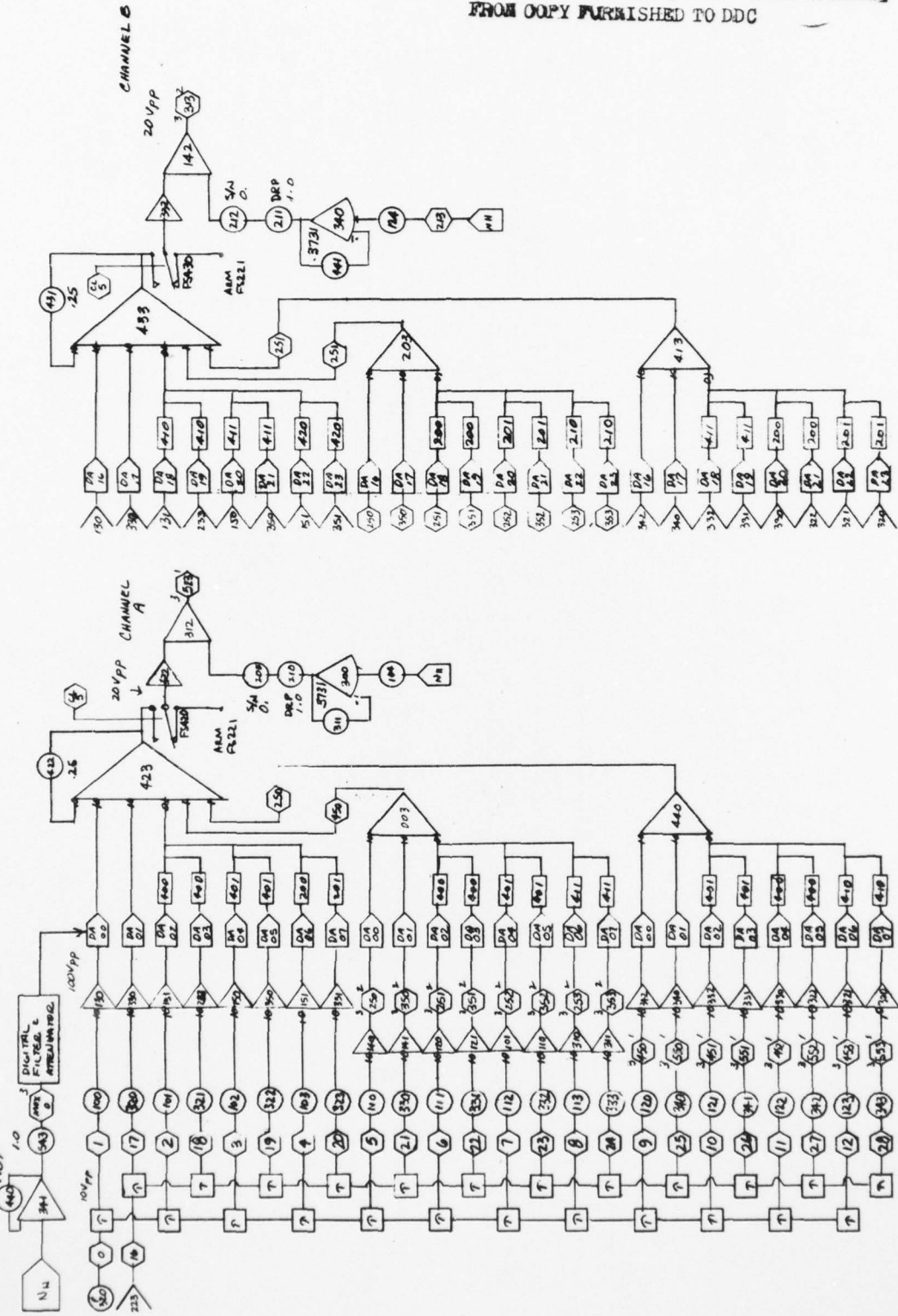

THIS PAGE IS BEST QUALITY PRACTICABLE
 FROM COPY FURNISHED TO DDC

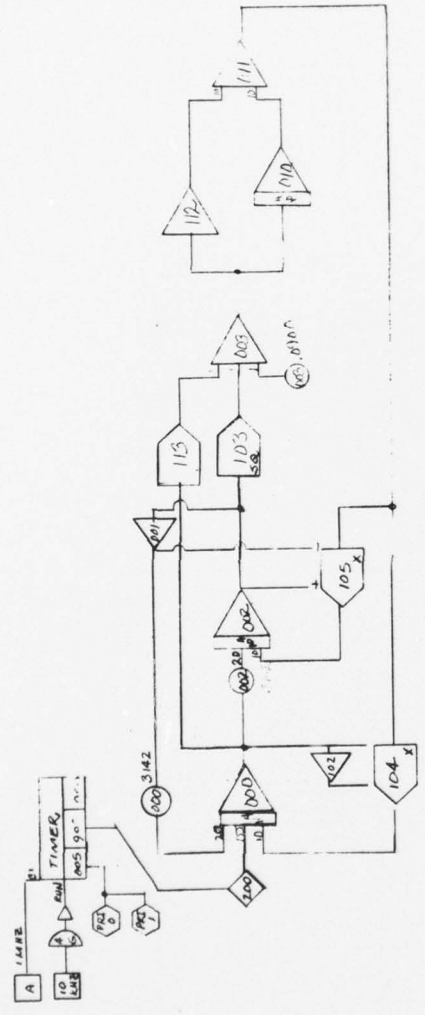

VCO C/151 73

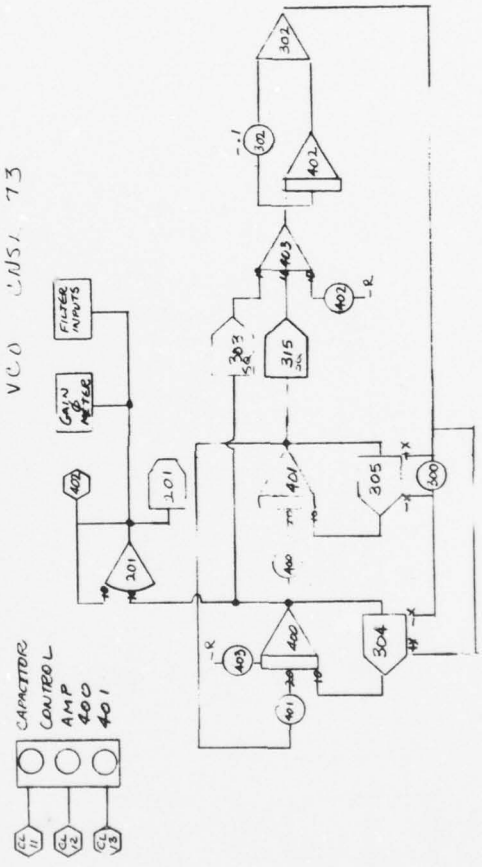

AD-A067 362

MARTIN MARIETTA AEROSPACE ORLANDO FLA
HYBRID COMPUTER SIMULATION STUDIES FOR SYSTEM CONTROL AND TRANS--ETC(U)

F/6 17/2

MAR 79 J K BISHOP, M K KLUKIS

DCA100-77-C-0061

UNCLASSIFIED

OR-15438

SBIE-AD-E100 195

NL

3 OF 3
AD
A067362

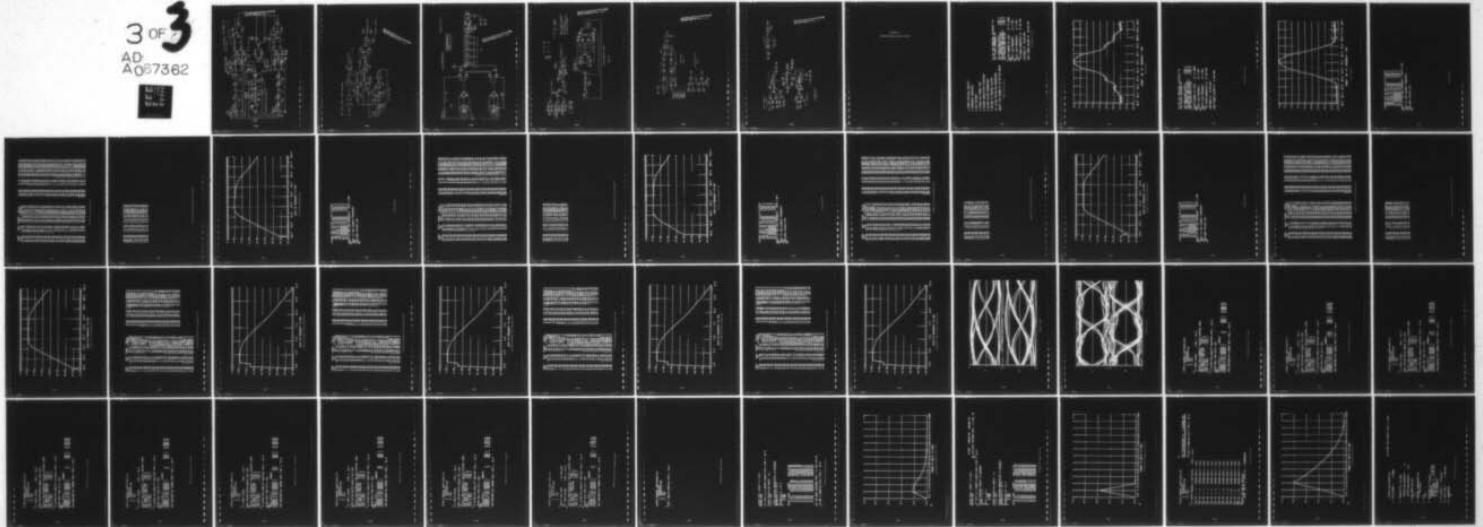

END
DATE
FILMED
6 -79
DDC



QPR - QPSK - DRAIN CLOCK RECOVERY

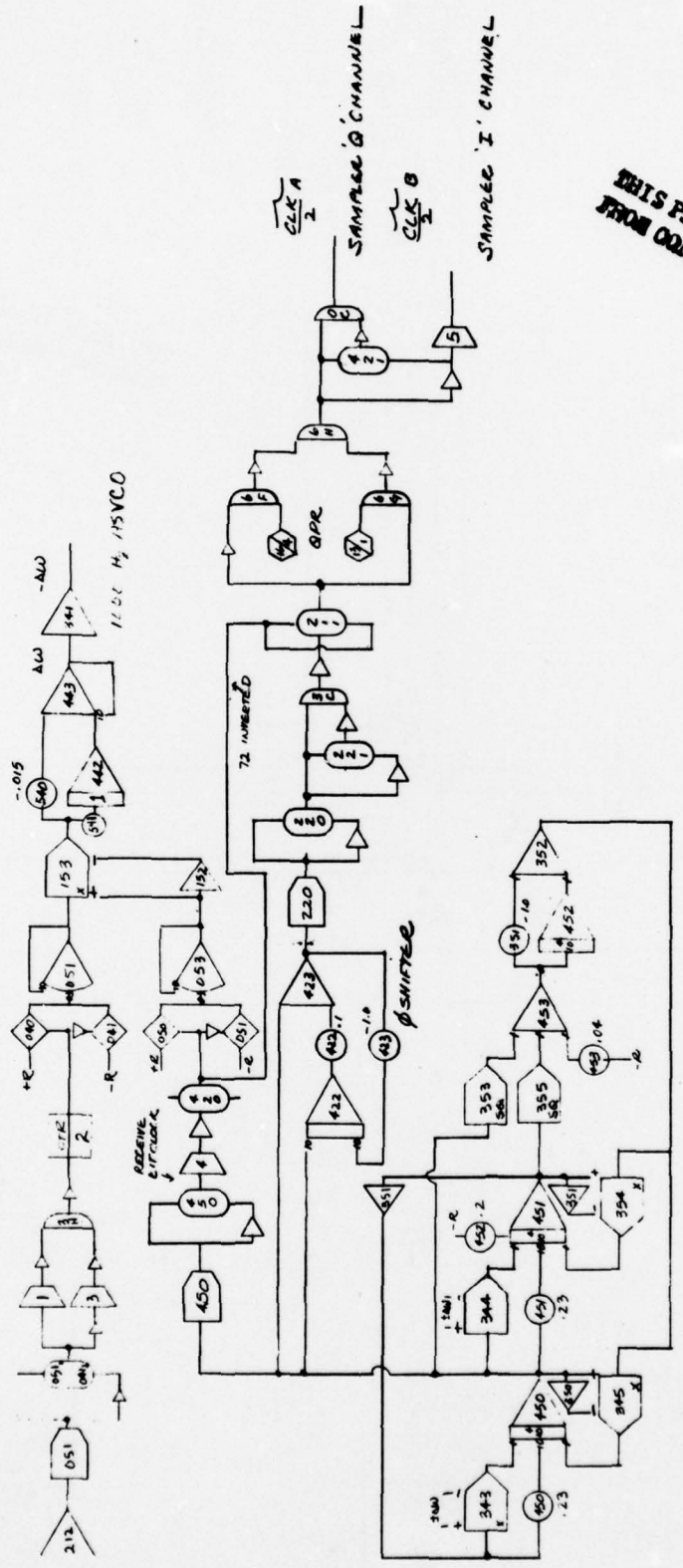

THIS PAGE IS BEST QUALITY PRACTICABLE
FROM COPY FURNISHED TO DDC

DATA REGENERATION

LOGIC TRAINING	QPR	QPSK
'14/12	0	1
'17/4	1	0

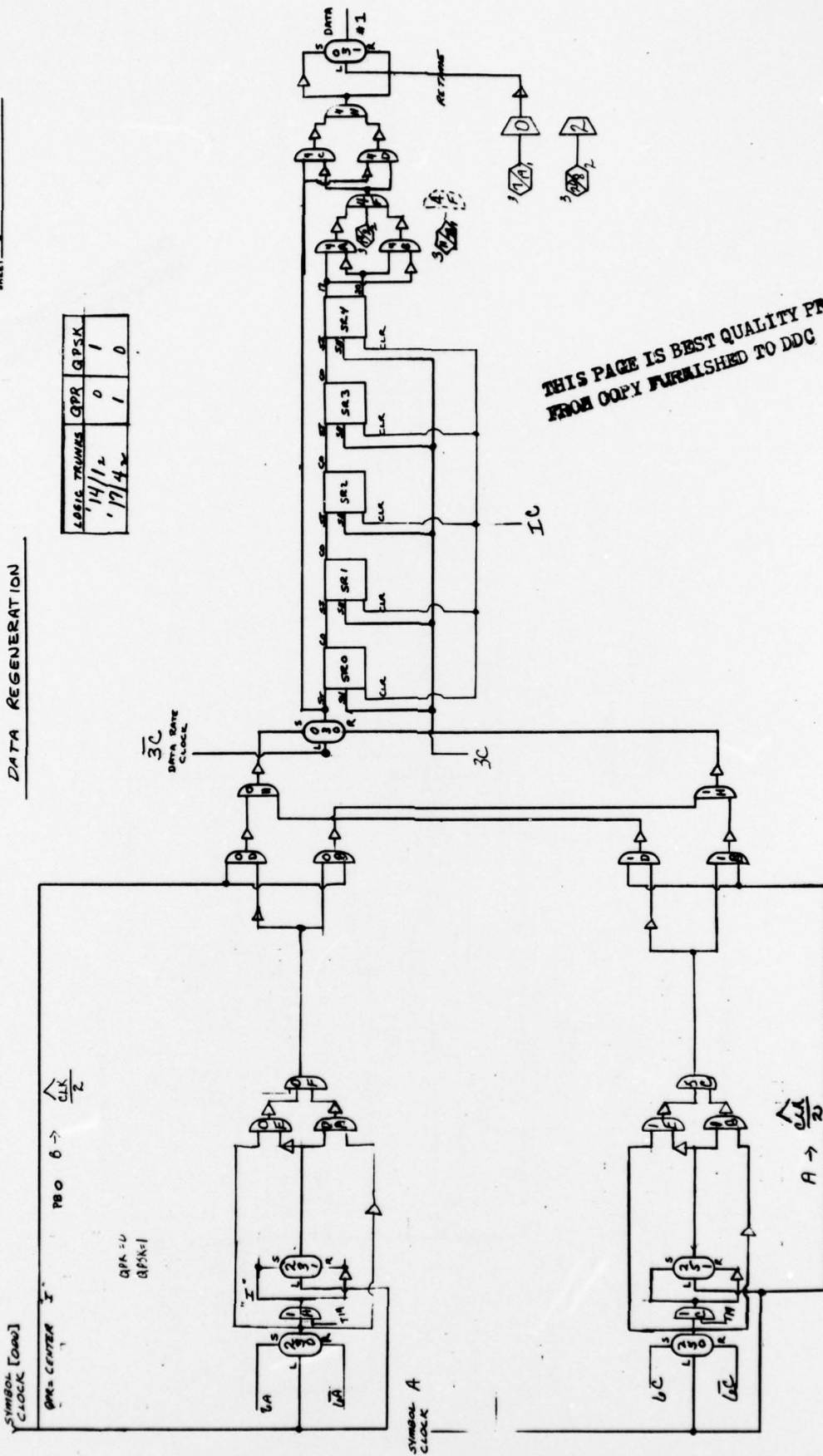

THIS PAGE IS BEST QUALITY PRACTICABLE
FROM COPY FURNISHED TO DDC

THIS PAGE IS BEST QUALITY PRACTICABLE
FROM COPY FURNISHED TO DDG

ABC	CL10	CL11	CL12
EYE	1	1	0
A ONLY	0	1	0
B ONLY	0	0	0

DIV SWITCH HIGH - CHANNEL B
LOW - CHANNEL A

ADJUST C [240, 242, 250, 252] TO
GIVE TWICE PEAK VALUE AT
A 240, 242, 252, 252.
SET C [241, 242, 250, 251] TO THE
SLICE VALUE OF PEAK/2

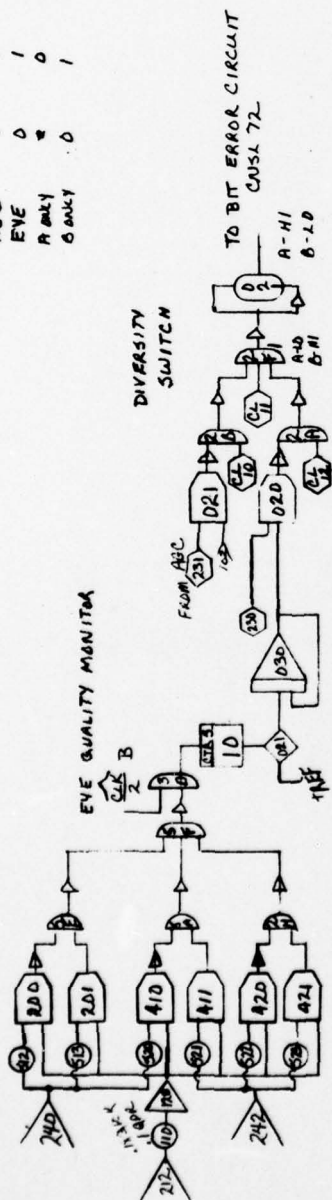

11 - ABOVE LEVEL
01 - WITHIN LEVEL
00 - BELOW LEVEL

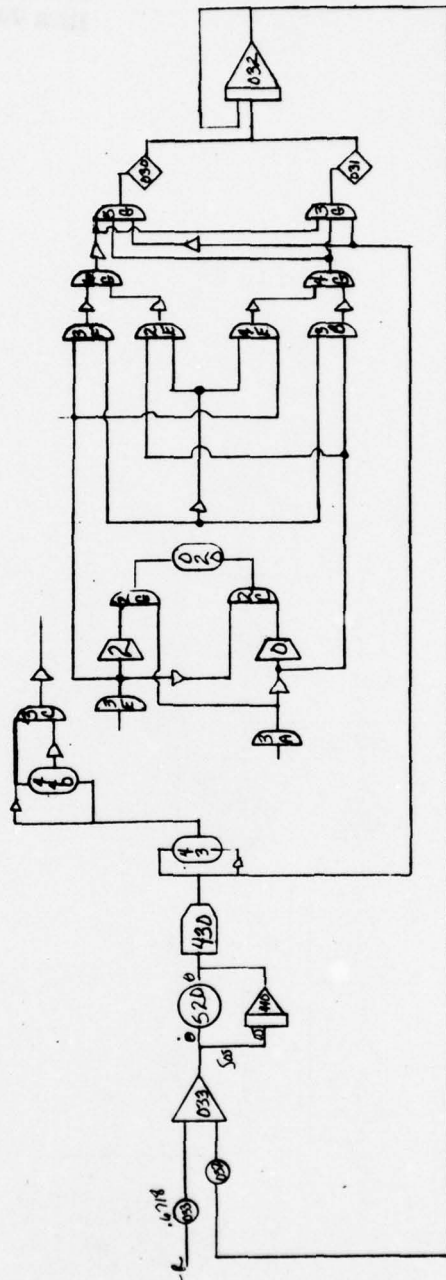

CLOCK AVERAGING CIRCUIT

CMSL 71

THIS PAGE IS BEST QUALITY PRACTICABLE
FROM COPY FURNISHED TO DDG

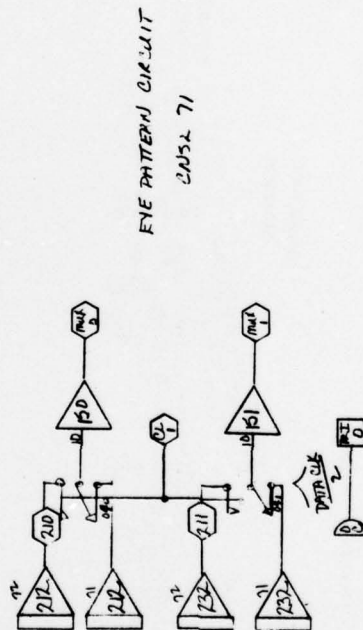
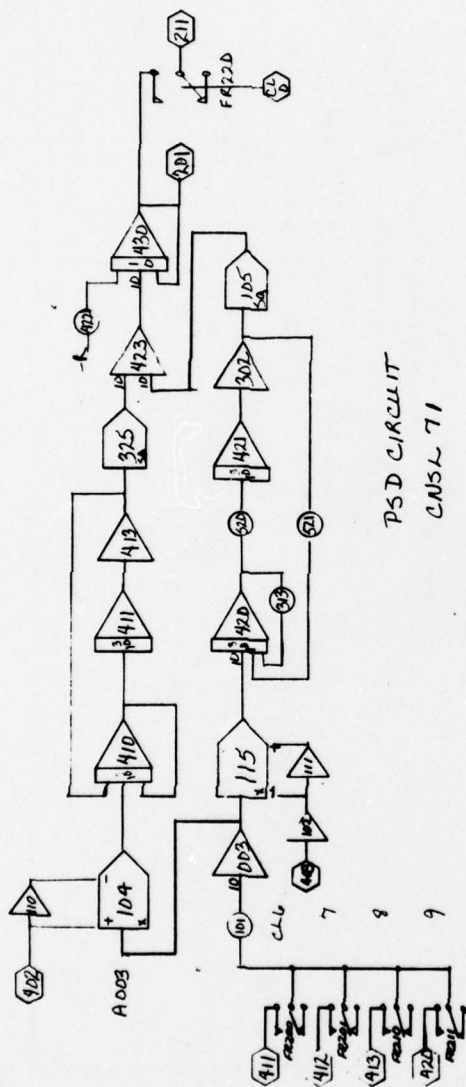

THIS PAGE IS BEST QUALITY PRACTICABLE
FROM COPY FURNISHED TO DDC

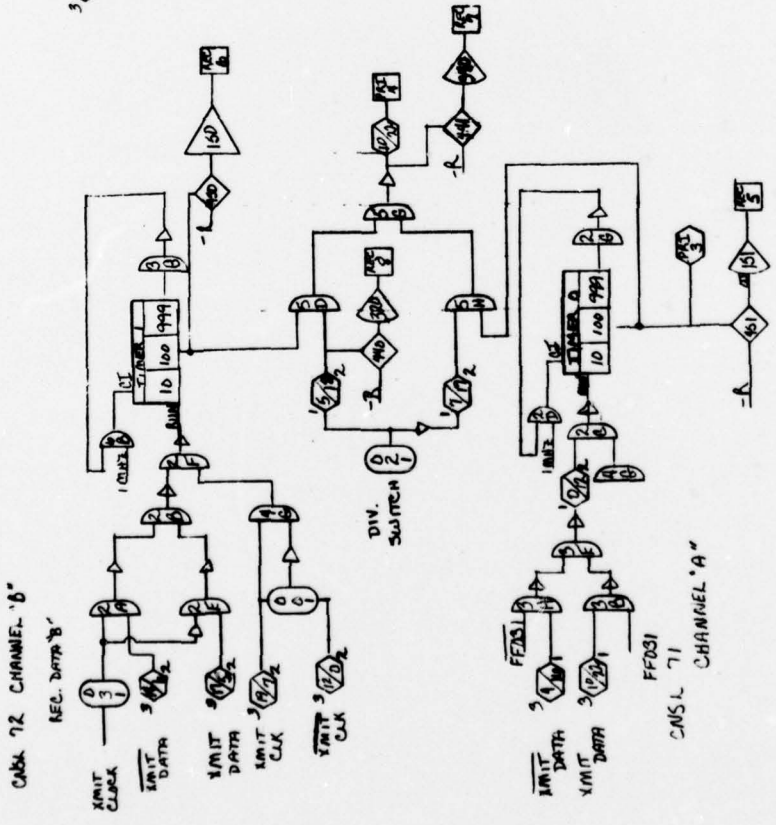
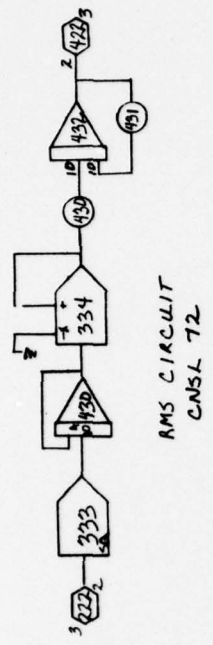

BIT ERROR CIRCUIT
CNSL 72

APPENDIX E
SOFTWARE SUPPORT GRAPHIC DISPLAYS

- 1. POWER SPECTRAL DENSITY
- 2. FREQUENCY RESPONSE
- 3. EYE PATTERN
- 4. SINGLE BIT ERROR TEST
- 5. CHOOSE MODULATION TECHNIQUE
- 8. ALTER FILTER PARAMETERS
- 9. RETURN TO NOMINAL SYSTEM
- 10. ALTER SYSTEM OR PARAMETERS

SELECT THE NUMBER OF AN OPTION ABOVE

DRAMA System Options

TO GET THE SPECTRAL OCCUPANCY OF THE SIGNAL MEASURED AT

THE MODULATOR OUTPUT TYPE 1
 1ST TRANSMITTER FILTER TYPE 2
 TRANSMITTER NONLINEARITY TYPE 3
 2ND TRANSMITTER FILTER TYPE 4

1 ENTER NUMBER OF LAGS ... UP TO 2000.
 200

INPUT LOW FREQUENCY ... XX.X MHZ

20 INPUT HIGH FREQUENCY ... XX.X MHZ

120

99 POWER BANDWIDTH IS 97.50 MHZ

CENTERED AT 70.00 MHZ

PEAK POWER OCCURS AT 69.00 MHZ

PSD Options - QPSK

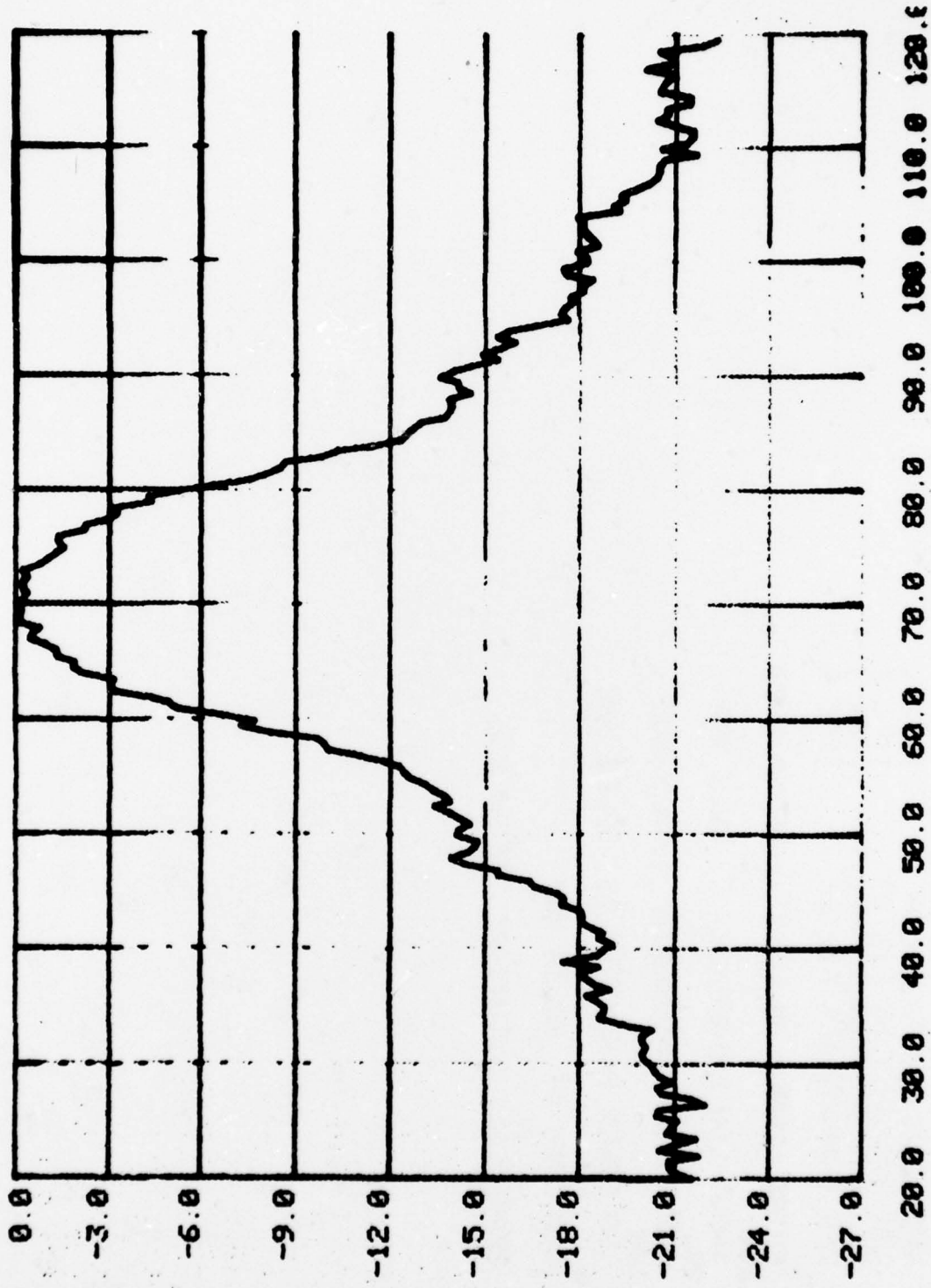

POWER - DB US FREQUENCY - MHZ

QPSK PSD Plot

TO GET THE SPECTRAL OCCUPANCY OF
THE SIGNAL MEASURED AT

THE MODULATOR OUTPUT TYPE 1
1ST TRANSMITTER FILTER TYPE 2
TRANSMITTER NONLINEARITY TYPE 3
2ND TRANSMITTER FILTER TYPE 4

1 ENTER NUMBER OF LAGS . . . UP TO 2000.
200

INPUT LOW FREQUENCY XX.X MHZ

20 INPUT HIGH FREQUENCY XX.X MHZ

120 99 POWER BANDWIDTH IS 97.00 MHZ

CENTERED AT 70.50 MHZ

PEAK POWER OCCURS AT 72.00 MHZ

PSD Options - QPR

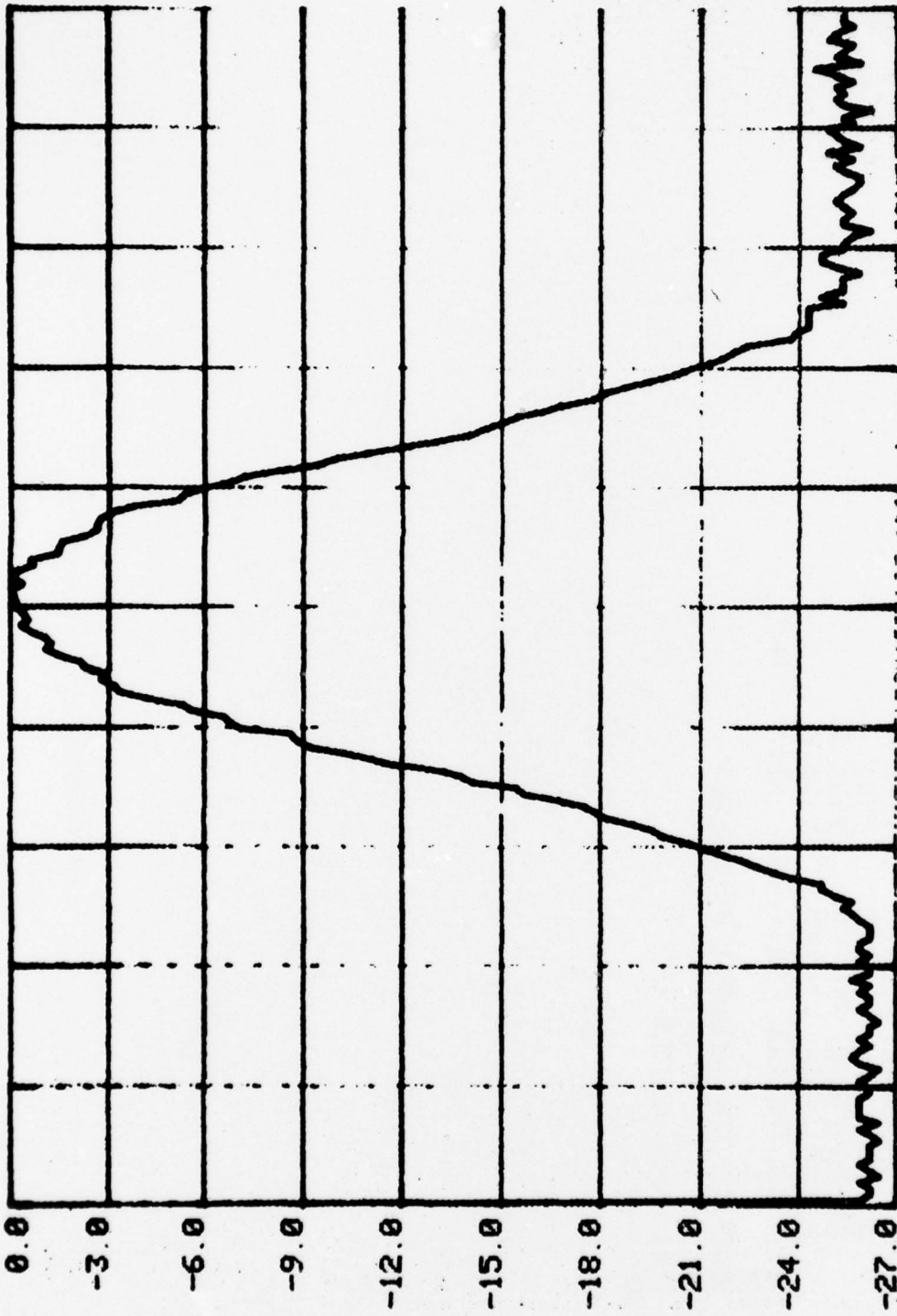

20.0 30.0 40.0 50.0 60.0 70.0 80.0 90.0 100.0 110.0 120.0

POWER - DB VS FREQUENCY - MHZ

QPR PSD Plot

CHOOSE THE FILTER TO BE PLOTTED
 1ST XMIT RF FILTER ... TYPE 1
 2ND XMIT RF FILTER ... TYPE 2
 1ST RCUR IF FILTER ... TYPE 3
 2ND RCUR IF FILTER ... TYPE 4
 A1 BASEBAND FILTER ... TYPE 5
 A2 BASEBAND FILTER ... TYPE 6
 B1 BASEBAND FILTER ... TYPE 7
 B2 BASEBAND FILTER ... TYPE 8
 1. WHAT IS THE LOW FREQUENCY XXXX.X MHZ
 20
 2. WHAT IS THE HIGHEST FREQUENCY
 120
 3. HOW MANY POINTS XXX.
 80

Filter Options

FREQ. MHZ	GAIN DB	PHASE DEG	DELAY MICROSEC
20.00	-42.00	-32.81	4557.29
21.25	-33.47	-28.10	3673.28
22.50	-32.19	-33.23	4102.16
23.75	-30.99	-35.45	4146.10
25.00	-29.29	-37.30	4144.96
26.25	-27.67	-39.21	4149.09
27.50	-26.20	-41.31	4172.58
28.75	-24.71	-43.04	4158.64
30.00	-23.32	-44.34	4105.17
31.25	-21.76	-46.19	4105.89
32.50	-20.27	-47.78	4083.61
33.75	-18.79	-49.56	4079.05
35.00	-17.25	-51.05	4051.56
36.25	-15.73	-52.73	4040.94
37.50	-14.22	-54.52	4038.25
38.75	-12.65	-55.93	4009.49
40.00	-11.11	-57.45	3989.31
41.25	-9.59	-59.18	3985.15
42.50	-8.05	-60.55	3957.30
43.75	-6.58	-62.01	3937.24
45.00	-5.21	-63.53	3921.31
46.25	-3.95	-64.75	3888.64
47.50	-2.82	-66.65	3897.67
48.75	-1.86	-67.94	3871.46
50.00	-1.13	-69.34	3851.98
51.25	-0.61	-70.83	3838.75
52.50	-0.24	-72.09	3814.52
53.75	-0.01	-73.07	3776.28
55.00	0.13	-74.63	3769.37
56.25	0.17	-75.81	3743.47
57.50	0.21	-77.22	3730.50
58.75	0.20	-78.42	3707.69
60.00	0.17	-79.54	3682.44
61.25			
62.50			
63.75			
65.00			
66.25			
67.50			
68.75			
70.00			
71.25			
72.50			
73.75			
75.00			
76.25			
77.50			
78.75			
80.00			
81.25			
82.50			
83.75			
85.00			
86.25			
87.50			
88.75			
90.00			
91.25			
92.50			
93.75			
95.00			
96.25			
97.50			
98.75			
100.00			
101.25			
102.50			
103.75			
61.25	0.16	-80	57-3653.79
62.50	0.11	-81	67-3629.54
63.75	0.08	-82	93-3613.69
65.00	0.03	-84	20-3598.45
66.25	-0.02	-85	45-3582.76
67.50	-0.08	-86	52-3560.62
68.75	-0.13	-87	84-3549.15
70.00	-0.19	-88	57-3514.84
71.25	-0.25	-89	77-3499.81
72.50	-0.30	-90	67-3474.08
73.75	-0.38	-91	85-3459.34
75.00	-0.45	-92	58-3428.81
76.25	-0.54	-93	38-3401.95
77.50	-0.62	-94	56-3389.09
78.75	-0.73	-95	73-3376.63
80.00	-0.85	-96	39-3346.76
81.25	-1.01	-97	39-3329.49
82.50	-1.17	-98	27-3308.64
83.75	-1.50	-99	10-3286.79
85.00	-1.56	-100	34-3279.15
86.25	-1.87	-101	39-3265.43
87.50	-2.18	-102	34-3249.01
88.75	-2.60	-102	76-3216.24
90.00	-3.05	-104	05-3211.51
91.25	-3.74	-104	64-3185.35
92.50	-4.24	-105	44-3166.50
93.75	-4.66	-106	32-3150.32
95.00	-5.21	-107	10-3131.72
96.25	-5.99	-107	76-3110.07
97.50	-6.66	-108	45-3089.68
98.75	-7.24	-109	30-3074.60
100.00	-7.71	-109	89-3052.45
101.25	-8.84	-110	57-3033.52
102.50	-9.31	-111	21-3013.72
103.75	-9.84	-111	89-2995.72

1st RF Filter Response Table

105.00	-10.84	-112.65	2980.08
106.25	-11.46	-113.31	2962.25
107.50	-12.18	-113.72	2938.53
108.75	-12.71	-114.55	2925.96
110.00	-13.28	-115.16	2908.12
111.25	-14.23	-116.02	2896.78
112.50	-14.51	-116.36	2873.04
113.75	-15.32	-116.89	2854.58
115.00	-15.78	-117.21	2831.22
116.25	-16.20	-118.07	2821.20
117.50	-17.01	-118.60	2803.88
118.75	-17.77	-119.17	2787.50
120.00	-18.26	-119.87	2774.86

1st RF Filter Response Table (Continued)

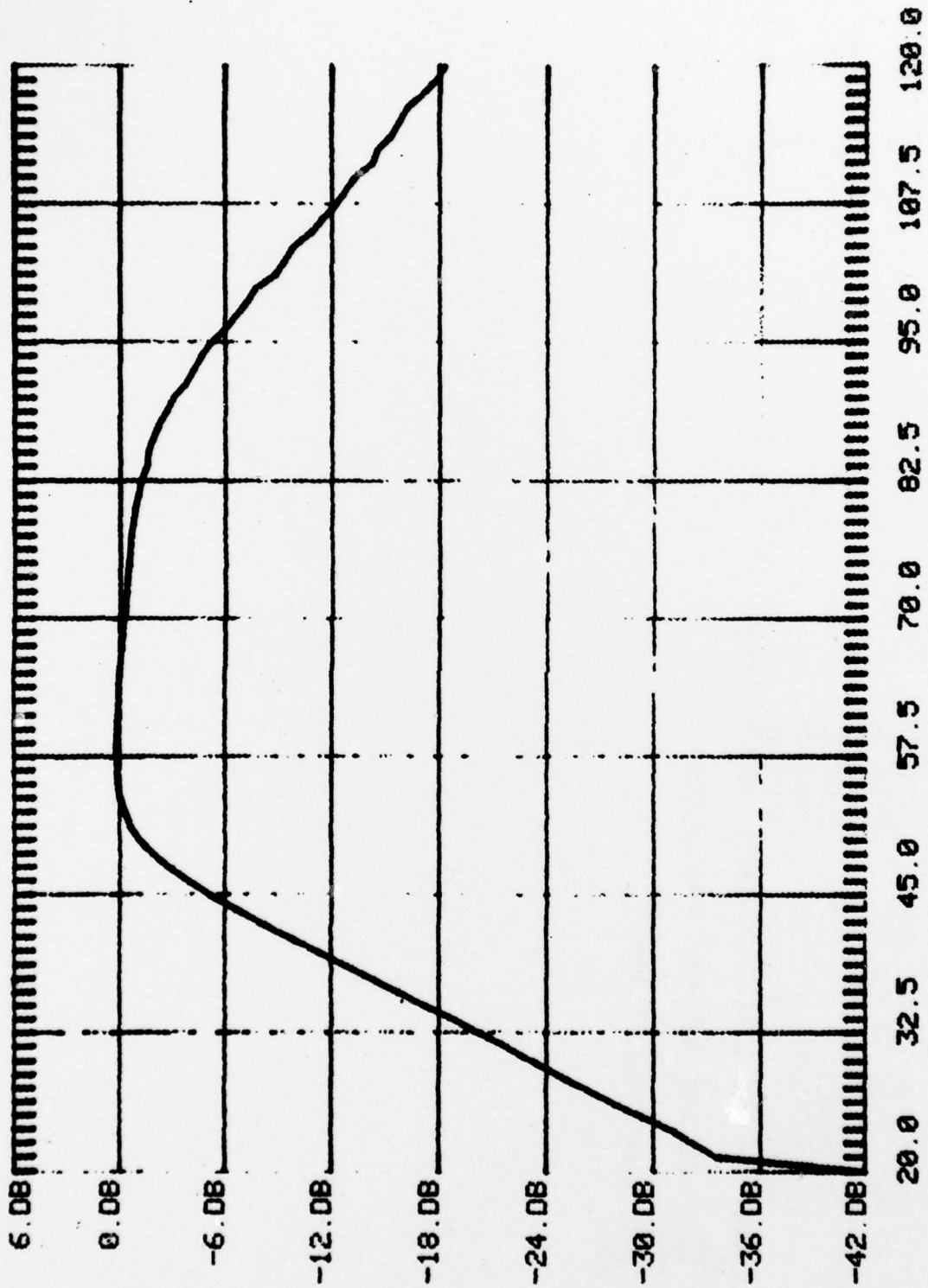

GAIN VS FREQUENCY IN MHZ

1st RF Filter Response Plot

CHOOSE THE FILTER TO BE PLOTTED
 1ST XMIT RF FILTER ... TYPE 1
 2ND XMIT RF FILTER ... TYPE 2
 1ST RCUR IF FILTER ... TYPE 3
 2ND RCUR IF FILTER ... TYPE 4
 A1 BASEBAND FILTER ... TYPE 5
 A2 BASEBAND FILTER ... TYPE 6
 B1 BASEBAND FILTER ... TYPE 7
 B2 BASEBAND FILTER ... TYPE 8
 2WHAT IS THE LOW FREQUENCY XXXX.X MHZ

20 WHAT IS THE HIGHEST FREQUENCY

120 HOW MANY POINTS XXX.
 80

Filter Options

FREQ. MHZ	GAIN DB	PHASE DEG	DELAY MICROSEC	61.25	0.23	-81.03
20.00	-39.55	-75.00	-10416.84	62.50	0.18	-81.98
21.25	-35.91	-17.46	-2281.84	63.75	0.18	-83.03
22.50	-33.47	-33.64	-4153.41	65.00	0.14	-84.30
23.75	-32.30	-35.62	-4166.09	66.25	0.11	-85.33
25.00	-30.53	-37.38	-4153.10	67.50	0.20	-86.77
26.25	-29.06	-39.53	-4182.68	68.75	0.05	-87.26
27.50	-27.23	-41.04	-4145.45	70.00	0.08	-88.55
28.75	-25.62	-42.77	-4132.69	71.25	0.01	-89.70
30.00	-24.05	-44.68	-4136.82	72.50	0.05	-90.75
31.25	-22.44	-45.97	-4086.36	73.75	0.12	-92.07
32.50	-20.78	-47.80	-4085.69	75.00	0.05	-92.75
33.75	-19.17	-49.54	-4077.04	76.25	0.22	-93.53
35.00	-17.59	-51.12	-4057.37	77.50	0.28	-94.50
36.25	-15.98	-52.69	-4037.20	78.75	0.32	-95.43
37.50	-14.36	-54.17	-4012.94	80.00	0.41	-96.51
38.75	-12.70	-56.05	-4018.24	81.25	0.63	-97.36
40.00	-11.12	-57.81	-4014.75	82.50	0.63	-98.32
41.25	-9.49	-59.08	-3978.58	83.75	0.36	-99.39
42.50	-7.88	-60.62	-3962.08	85.00	1.24	-100.88
43.75	-6.35	-62.18	-3948.09	86.25	1.53	-101.37
45.00	-4.88	-63.65	-3928.84	87.50	1.08	-102.08
46.25	-3.55	-65.23	-3917.97	88.75	2.72	-102.78
47.50	-2.35	-66.28	-3876.25	90.00	2.92	-103.86
48.75	-1.42	-67.92	-3870.07	91.25	2.51	-104.47
50.00	-0.73	-69.53	-3862.83	92.50	4.11	-105.18
51.25	-0.26	-70.63	-3828.16	93.75	4.05	-106.59
52.50	0.07	-71.95	-3806.77	95.00	5.27	-106.88
53.75	0.23	-73.00	-3772.49	96.25	6.25	-107.81
55.00	0.30	-74.73	-3774.30	97.50	7.08	-108.86
56.25	0.32	-75.95	-3750.71	98.75	7.57	-109.45
57.50	0.32	-77.17	-3728.14	100.00	7.02	-110.23
58.75	0.29	-78.22	-3698.46	101.25	8.93	-110.55
60.00	0.27	-79.66	-3688.09	102.50	9.75	-110.94
				103.75		-111.62

2nd RF Filter Response Table

105.00	-9.60	-113.23	23-2995	58
106.25	-11.26	-113.43	43-2965	44
107.50	-11.73	-113.89	89-2942	95
108.75	-12.61	-114.40	40-2922	22
110.00	-12.97	-115.16	16-2908	12
111.25	-13.59	-116.14	14-2899	83
112.50	-14.23	-116.50	50-2876	65
113.75	-14.75	-116.97	97-2856	37
115.00	-15.48	-117.24	24-2831	81
116.25	-15.98	-118.04	04-2820	62
117.50	-16.64	-118.60	60-2803	88
118.75	-17.47	-119.36	36-2792	07
120.00	-17.65	-120.21	21-2782	77

2nd RF Filter Response Table (Continued)

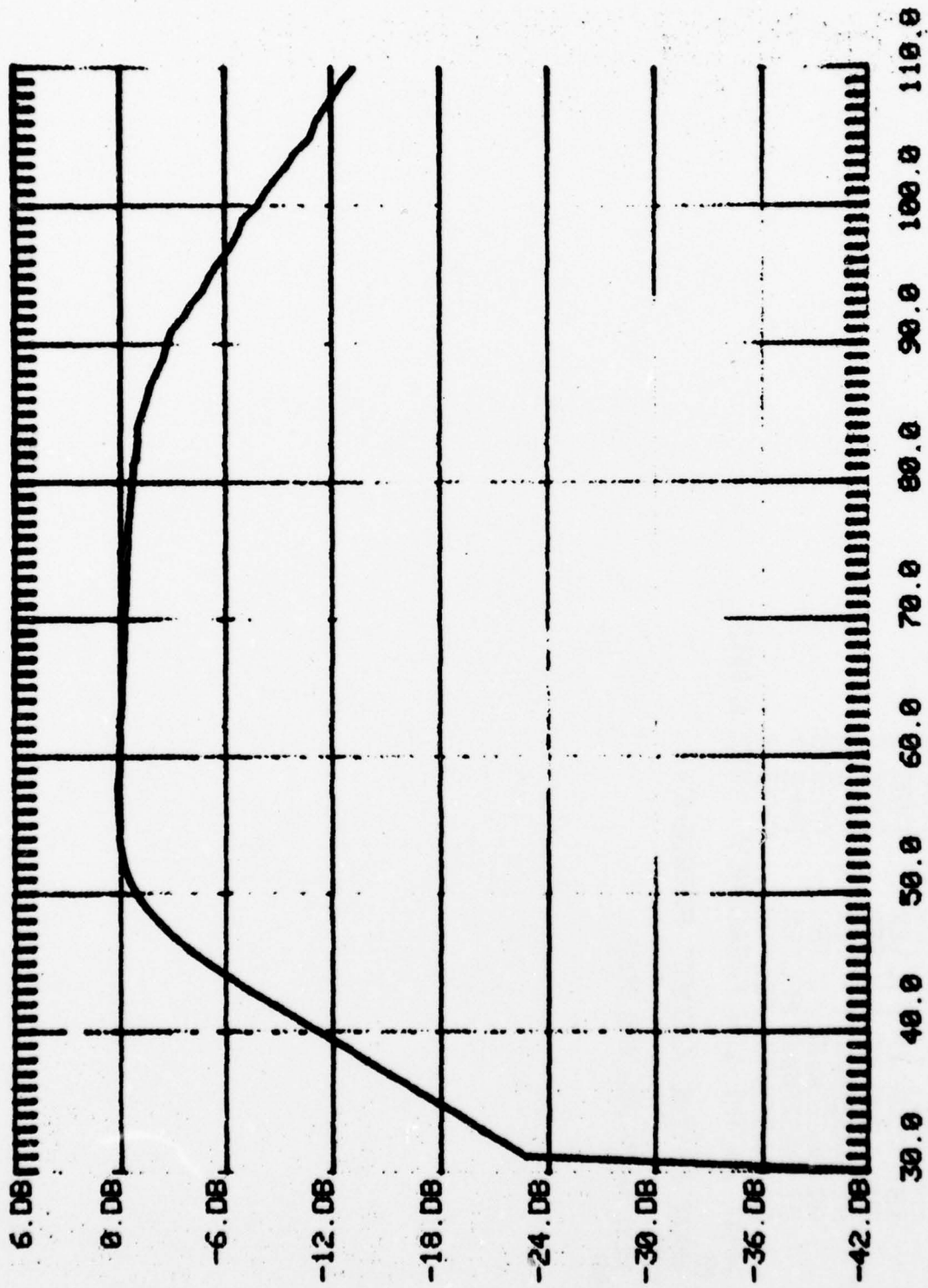

GAIN VS FREQUENCY IN MHZ

2nd RF Filter Response Plot

CHOOSE THE FILTER TO BE PLOTTED
 1ST XMIT RF FILTER ... TYPE 1
 2ND XMIT RF FILTER ... TYPE 2
 1ST RCVR IF FILTER ... TYPE 3
 2ND RCVR IF FILTER ... TYPE 4
 A1 BASEBAND FILTER ... TYPE 5
 A2 BASEBAND FILTER ... TYPE 6
 B1 BASEBAND FFLTER ... TYPE 7
 B2 BASEBAND FILTER ... TYPE 8
 WHAT IS THE LOW FREQUENCY XXXX.X MHZ
 20.

WHAT IS THE HIGHEST FREQUENCY
 120.
 HOW MANY POINTS XXX.
 80.

Filter Options

FREQ. MHZ	GAIN DB	PHASE DEG.	DELAY MICROSEC
20.00	-30.01	-74.63	10365.42
21.25	-34.82	-49.80	6510.42
22.50	-33.35	-89.60	11061.42
23.75	-31.77	-90.31	10562.42
25.00	-30.53	-89.55	9950.08
26.25	-29.06	-89.50	9471.09
27.50	-27.36	-89.75	9065.25
28.75	-26.04	-89.67	8664.02
30.00	-24.44	-89.40	8278.16
31.25	-22.98	-89.89	7990.43
32.50	-21.51	-89.99	7691.45
33.75	-19.95	-89.70	7382.47
35.00	-18.37	-90.43	7176.94
36.25	-16.71	-89.23	6837.79
37.50	-15.18	-89.55	6633.37
38.75	-13.60	-90.14	6461.39
40.00	-11.95	-89.50	6215.39
41.25	-10.43	-89.75	6043.49
42.50	-8.88	-89.67	5860.95
43.75	-7.35	-89.23	5665.59
45.00	-5.86	-90.04	5557.95
46.25	-4.52	-89.84	5396.00
47.50	-3.34	-89.43	5229.73
48.75	-2.35	-90.04	5130.41
50.00	-1.62	-89.43	4968.25
51.25	-1.07	-89.40	4845.75
52.50	-0.70	-89.89	4756.20
53.75	-0.51	-89.84	4643.07
55.00	-0.37	-89.48	4519.05
56.25	-0.31	-89.43	4416.21
57.50	-0.28	-90.09	4352.05
58.75	-0.27	-89.77	4244.45
60.00	-0.28	-90.01	4167.32
61.25			
62.50			
63.75			
65.00			
66.25			
67.50			
70.00			
71.25			
72.50			
73.75			
75.00			
76.25			
77.50			
78.75			
80.00			
81.25			
82.50			
83.75			
85.00			
86.25			
87.50			
88.75			
90.00			
91.25			
92.50			
93.75			
95.00			
96.25			
97.50			
98.75			
100.00			
101.25			
102.50			
103.75			
61.25			
62.50			
63.75			
65.00			
66.25			
67.50			
70.00			
71.25			
72.50			
73.75			
75.00			
76.25			
77.50			
78.75			
80.00			
81.25			
82.50			
83.75			
85.00			
86.25			
87.50			
88.75			
90.00			
91.25			
92.50			
93.75			
95.00			
96.25			
97.50			
98.75			
100.00			
101.25			
102.50			
103.75			
61.25			
62.50			
63.75			
65.00			
66.25			
67.50			
70.00			
71.25			
72.50			
73.75			
75.00			
76.25			
77.50			
78.75			
80.00			
81.25			
82.50			
83.75			
85.00			
86.25			
87.50			
88.75			
90.00			
91.25			
92.50			
93.75			
95.00			
96.25			
97.50			
98.75			
100.00			
101.25			
102.50			
103.75			
61.25			
62.50			
63.75			
65.00			
66.25			
67.50			
70.00			
71.25			
72.50			
73.75			
75.00			
76.25			
77.50			
78.75			
80.00			
81.25			
82.50			
83.75			
85.00			
86.25			
87.50			
88.75			
90.00			
91.25			
92.50			
93.75			
95.00			
96.25			
97.50			
98.75			
100.00			
101.25			
102.50			
103.75			
61.25			
62.50			
63.75			
65.00			
66.25			
67.50			
70.00			
71.25			
72.50			
73.75			
75.00			
76.25			
77.50			
78.75			
80.00			
81.25			
82.50			
83.75			
85.00			
86.25			
87.50			
88.75			
90.00			
91.25			
92.50			
93.75			
95.00			
96.25			
97.50			
98.75			
100.00			
101.25			
102.50			
103.75			
61.25			
62.50			
63.75			
65.00			
66.25			
67.50			
70.00			
71.25			
72.50			
73.75			
75.00			
76.25			
77.50			
78.75			
80.00			
81.25			
82.50			
83.75			
85.00			
86.25			
87.50			
88.75			
90.00			
91.25			
92.50			
93.75			
95.00			
96.25			
97.50			
98.75			
100.00			
101.25			
102.50			
103.75			
61.25			
62.50			
63.75			
65.00			
66.25			
67.50			
70.00			
71.25			
72.50			
73.75			
75.00			
76.25			
77.50			
78.75			
80.00			
81.25			
82.50			
83.75			
85.00			
86.25			
87.50			
88.75			
90.00			
91.25			
92.50			
93.75			
95.00			
96.25			
97.50			
98.75			
100.00			
101.25			
102.50			
103.75			
61.25			
62.50			
63.75			
65.00			
66.25			
67.50			
70.00			
71.25			
72.50			
73.75			
75.00			
76.25			
77.50			
78.75			
80.00			
81.25			
82.50			
83.75			
85.00			
86.25			
87.50			
88.75			
90.00			
91.25			
92.50			
93.75			
95.00			
96.25			
97.50			
98.75			
100.00			
101.25			
102.50			
103.75			
61.25			
62.50			
63.75			
65.00			
66.25			
67.50			
70.00			
71.25			
72.50			
73.75			
75.00			
76.25			
77.50			
78.75			
80.00			
81.25			
82.50			
83.75			
85.00			
86.25			
87.50			
88.75			
90.00			
91.25			
92.50			
93.75			
95.00			
96.25			
97.50			
98.75			
100.00			
101.25			
102.50			
103.75			
61.25			
62.50			
63.75			
65.00			
66.25			
67.50			
70.00			
71.25			
72.50			
73.75			
75.00			
76.25			
77.50			
78.75			
80.00			
81.25			
82.50			
83.75			
85.00			
86.25			
87.50			
88.75			
90.00			
91.25			
92.50			
93.75			
95.00			
96.25			
97.50			
98.75			
100.00			
101.25			
102.50			
103.75			
61.25			
62.50			
63.75			
65.00			
66.25			
67.50			
70.00			
71.25			
72.50			
73.75			
75.00			
76.25			
77.50			
78.75			
80.00			
81.25			
82.50			
83.75			
85.00			
86.25			
87.50			
88.75			
90.00			
91.25			
92.50			
93.75			
95.00			
96.25			
97.50			
98.75			
100.00			
101.25			
102.50			
103.75			
61.25			
62.50			
63.75			
65.00			
66.25			
67.50			
70.00			
71.25			
72.50			
73.75			
75.00			
76.25			
77.50			
78.75			
80.00			
81.25			
82.50			
83.75			
85.00			
86.25			
87.50			
88.75			
90.00			

105.00	-9.84	-89.99	2380.71
106.25	-10.23	-89.21	2332.27
107.50	-10.81	-90.21	2331.02
108.75	-11.35	-89.06	2274.92
110.00	-12.05	-89.58	2262.01
111.25	-12.69	-89.36	2231.11
112.50	-13.08	-89.33	2205.71
113.75	-13.53	-89.09	2175.52
115.00	-14.45	-89.45	2160.71
116.25	-14.75	-89.60	2140.98
117.50	-15.17	-89.45	2114.74
118.75	-15.86	-89.79	2100.48
120.00	-16.48	-89.67	2075.77

Channel A IF Filter Response Table (Continued)

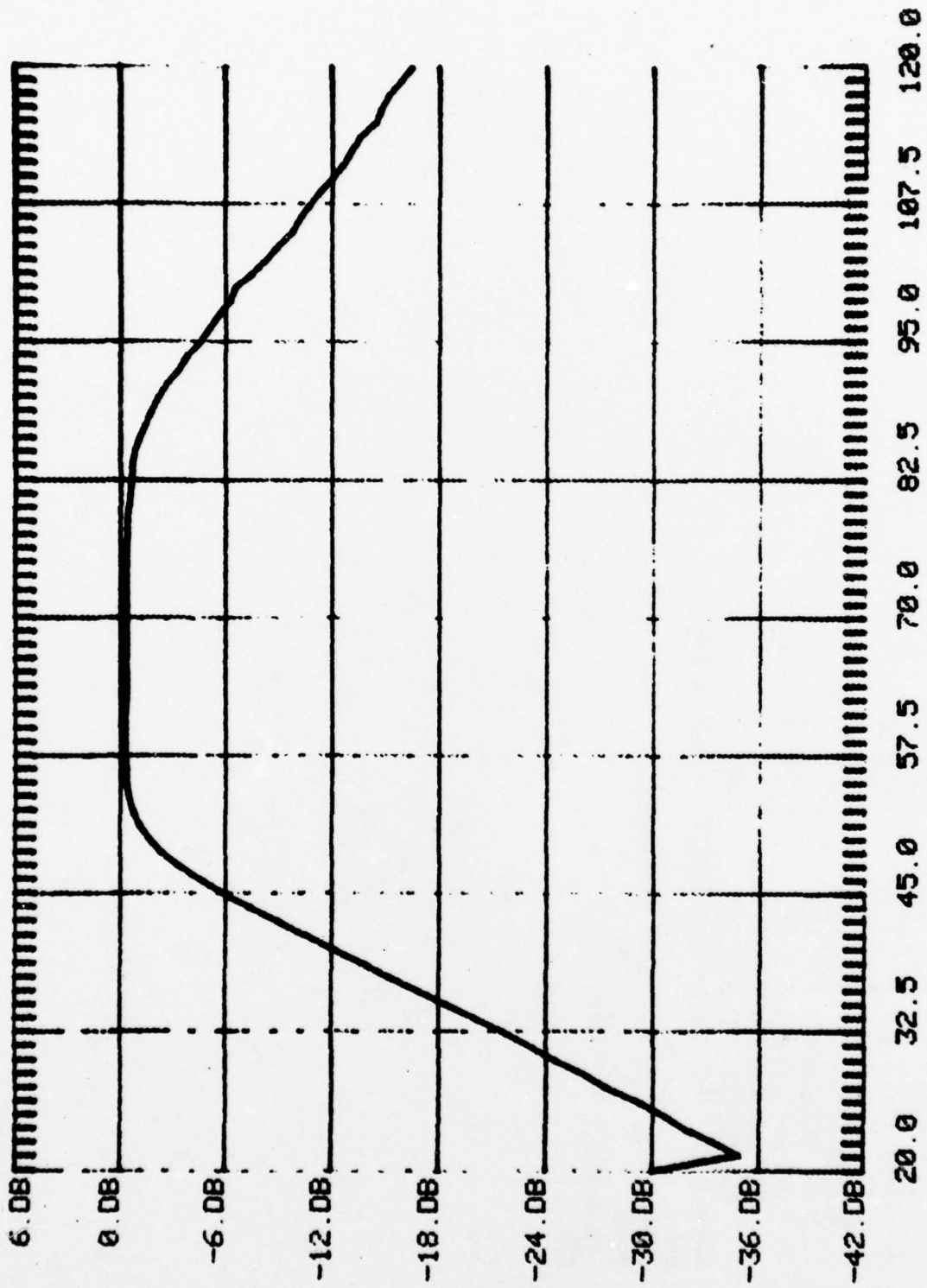

Channel A IF Filter Response Plot

CHOOSE THE FILTER TO BE PLOTTED
1ST XMIT RF FILTER ... TYPE 1
2ND XMIT RF FILTER ... TYPE 2
1ST RCUR IF FILTER ... TYPE 3
2ND RCUR IF FILTER ... TYPE 4
A1 BASEBAND FILTER ... TYPE 5
A2 BASEBAND FILTER ... TYPE 6
B1 BASEBAND FILTER ... TYPE 7
B2 BASEBAND FILTER ... TYPE 8
WHAT IS THE LOW FREQUENCY XXXX.X MHZ
20.

WHAT IS THE HIGHEST FREQUENCY
120.

HOW MANY POINTS XXX.
80.

Filter Options

FREQ. MHZ	GAIN DB	PHASE DEG	DELAY MICROSEC
20.00	-41.21	-74.80	10389 *
21.25	-35.12	-49.83	6513.61
22.50	-33.72	-90.75	-11203 *
23.75	-32.30	-90.04	-10530 *
25.00	-30.80	-89.67	9963.64
26.25	-29.21	-89.50	9471.09
27.50	-27.67	-89.92	9082.51
28.75	-26.25	-89.60	8656.95
30.00	-24.71	-89.67	8303.02
31.25	-23.17	-89.65	7968.73
32.50	-21.73	-90.06	7697.71
33.75	-20.19	-89.70	7382.47
35.00	-18.59	-89.60	7111.06
36.25	-17.06	-89.53	6860.24
37.50	-15.54	-89.38	6620.71
38.75	-13.95	-89.60	6422.89
40.00	-12.42	-89.67	6227.26
41.25	-10.81	-89.87	6051.71
42.50	-9.30	-89.58	5854.57
43.75	-7.80	-89.84	5704.35
45.00	-6.37	-89.53	5526.30
46.25	-5.05	-89.18	5356.41
47.50	-3.89	-89.04	5206.68
48.75	-2.87	-89.87	4998.09
50.00	-2.14	-89.97	4998.09
51.25	-1.57	-89.50	4851.04
52.50	-1.15	-90.04	4763.95
53.75	-0.92	-89.65	4632.98
55.00	-0.76	-89.48	4519.05
56.25	-0.70	-89.94	4441.53
57.50	-0.64	-89.53	4324.93
58.75	-0.63	-90.23	4266.38
60.00	-0.64	-89.82	4158.29
61.25	103.75		
62.50	102.50		
63.75	101.25		
65.00	100.00		
66.25	98.75		
67.50	97.50		
68.75	96.25		
70.00	95.00		
71.25	93.75		
72.50	92.50		
73.75	91.25		
75.00	90.00		
76.25	88.75		
77.50	87.50		
78.75	86.25		
80.00	85.00		
81.25	83.75		
82.50	82.50		
83.75	81.25		
85.00	80.00		
86.25	78.75		
87.50	77.50		
88.75	76.25		
90.00	75.00		
91.25	73.75		
92.50	72.50		
93.75	71.25		
95.00	70.00		
96.25	68.75		
97.50	67.50		
98.75	66.25		
100.00	65.00		
101.25	63.75		
102.50	62.50		
103.75	61.25		
	60.00		
	58.75		
	57.50		
	56.25		
	55.00		
	53.75		
	52.50		
	51.25		
	50.00		
	48.75		
	47.50		
	46.25		
	45.00		
	43.75		
	42.50		
	41.25		
	40.00		
	38.75		
	37.50		
	36.25		
	35.00		
	33.75		
	32.50		
	31.25		
	30.00		
	28.75		
	27.50		
	26.25		
	25.00		
	23.75		
	22.50		
	21.25		
	20.00		
	18.75		
	17.50		
	16.25		
	15.00		
	13.75		
	12.50		
	11.25		
	10.00		
	8.75		
	7.50		
	6.25		
	5.00		
	3.75		
	2.50		
	1.25		
	0.00		
	-1.25		
	-2.50		
	-3.75		
	-5.00		
	-6.25		
	-7.50		
	-8.75		
	-10.00		
	-11.25		
	-12.50		
	-13.75		
	-15.00		
	-16.25		
	-17.50		
	-18.75		
	-20.00		
	-21.25		
	-22.50		
	-23.75		
	-25.00		
	-26.25		
	-27.50		
	-28.75		
	-30.00		
	-31.25		
	-32.50		
	-33.75		
	-35.00		
	-36.25		
	-37.50		
	-38.75		
	-40.00		
	-41.25		
	-42.50		
	-43.75		
	-45.00		
	-46.25		
	-47.50		
	-48.75		
	-50.00		
	-51.25		
	-52.50		
	-53.75		
	-55.00		
	-56.25		
	-57.50		
	-58.75		
	-60.00		
	-61.25		
	-62.50		
	-63.75		
	-65.00		
	-66.25		
	-67.50		
	-68.75		
	-70.00		
	-71.25		
	-72.50		
	-73.75		
	-75.00		
	-76.25		
	-77.50		
	-78.75		
	-80.00		
	-81.25		
	-82.50		
	-83.75		
	-85.00		
	-86.25		
	-87.50		
	-88.75		
	-90.00		
	-91.25		
	-92.50		
	-93.75		
	-95.00		
	-96.25		
	-97.50		
	-98.75		
	-100.00		
	-101.25		
	-102.50		
	-103.75		
	-105.00		
	-106.25		
	-107.50		
	-108.75		
	-110.00		
	-111.25		
	-112.50		
	-113.75		
	-115.00		
	-116.25		
	-117.50		
	-118.75		
	-120.00		
	-121.25		
	-122.50		
	-123.75		
	-125.00		
	-126.25		
	-127.50		
	-128.75		
	-130.00		
	-131.25		
	-132.50		
	-133.75		
	-135.00		
	-136.25		
	-137.50		
	-138.75		
	-140.00		
	-141.25		
	-142.50		
	-143.75		
	-145.00		
	-146.25		
	-147.50		
	-148.75		
	-150.00		
	-151.25		
	-152.50		
	-153.75		
	-155.00		
	-156.25		
	-157.50		
	-158.75		
	-160.00		
	-161.25		
	-162.50		
	-163.75		
	-165.00		
	-166.25		
	-167.50		
	-168.75		
	-170.00		
	-171.25		
	-172.50		
	-173.75		
	-175.00		
	-176.25		
	-177.50		
	-178.75		
	-180.00		
	-181.25		
	-182.50		
	-183.75		
	-185.00		
	-186.25		
	-187.50		
	-188.75		
	-190.00		
	-191.25		
	-192.50		
	-193.75		
	-195.00		
	-196.25		
	-197.50		
	-198.75		
	-200.00		
	-201.25		
	-202.50		
	-203.75		
	-205.00		
	-206.25		
	-207.50		
	-208.75		
	-210.00		
	-211.25		
	-212.50		
	-213.75		
	-215.00		
	-216.25		
	-217.50		
	-218.75		
	-220.00		
	-221.25		
	-222.50		
	-223.75		
	-225.00		
	-226.25		
	-227.50		
	-228.75		
	-230.00		
	-231.25		
	-232.50		
	-233.75		
	-235.00		
	-236.25		
	-237.50		
	-238.75		
	-240.00		
	-241.25		
	-242.50		
	-243.75		
	-245.00		
	-246.25		
	-247.50		
	-248.75		
	-250.00		
	-251.25		
	-252.50		
	-253.75		
	-255.00		
	-256.25		
	-257.50		
	-258.75		
	-260.00		
	-261.25		
	-262.50		
	-263.75		
	-265.00		
	-266.25		
	-267.50		
	-268.75		
	-270.00		
	-271.25		
	-272.50		
	-273.75		
	-275.00		
	-276.25		
	-277.50		
	-278.75		
	-280.00		
	-281.25		
	-282.50		
	-283.75		
	-285.00		
	-286.25		
	-287.50		
	-288.75		
	-290.00		
	-291.25		
	-292.50		
	-293.75		
	-295.00		
	-296.25		
	-297.50		
	-298.75		
	-300.00		
	-301.25		
	-302.50		
	-303.75		
	-305.00		
	-306.25		
	-307.50		
	-308.75		
	-310.00		
	-311.25		
	-312.50		
	-313.75		
	-315.00		
	-316.25		
	-317.50		
	-318.75		
	-320.00		
	-321.25		
	-322.50		
	-323.75		
	-325.00		
	-326.25		
	-327.50		
	-328.75		
	-330.00		
	-331.25		
	-332.50		
	-333.75		
	-335.00		
	-336.25		
	-337.50		
	-338.75		
	-340.00		
	-341.25		
	-342.50		
	-343.75		
	-345.00		
	-346.25		
	-347.50		
	-348.75		
	-350.00		
	-351.25		
	-352.50		
	-353.75		
	-355.00		
	-356.25		
	-357.50		
	-358.75		
	-360.00		
	-361.25		
	-362.50		
	-363.75		
	-365.00		
	-366.25		
	-367.50		
	-368.75		
	-370.00		
	-371.25		
	-372.50		
	-373.75		

105.00	-8.68	-89.97	2380.06
106.25	-9.94	-89.79	2347.59
107.50	-10.67	-89.94	2324.08
108.75	-11.31	-89.94	2297.36
110.00	-11.86	-90.36	2281.74
111.25	-12.13	-89.72	2240.25
112.50	-12.87	-89.28	2204.51
113.75	-13.35	-89.67	2189.82
115.00	-13.95	-89.67	2166.02
116.25	-14.48	-89.84	2146.82
117.50	-14.88	-90.06	2129.17
118.75	-15.77	-89.31	2089.06
120.00	-16.20	-89.43	2070.12

Channel B IF Filter Response Table (Continued)

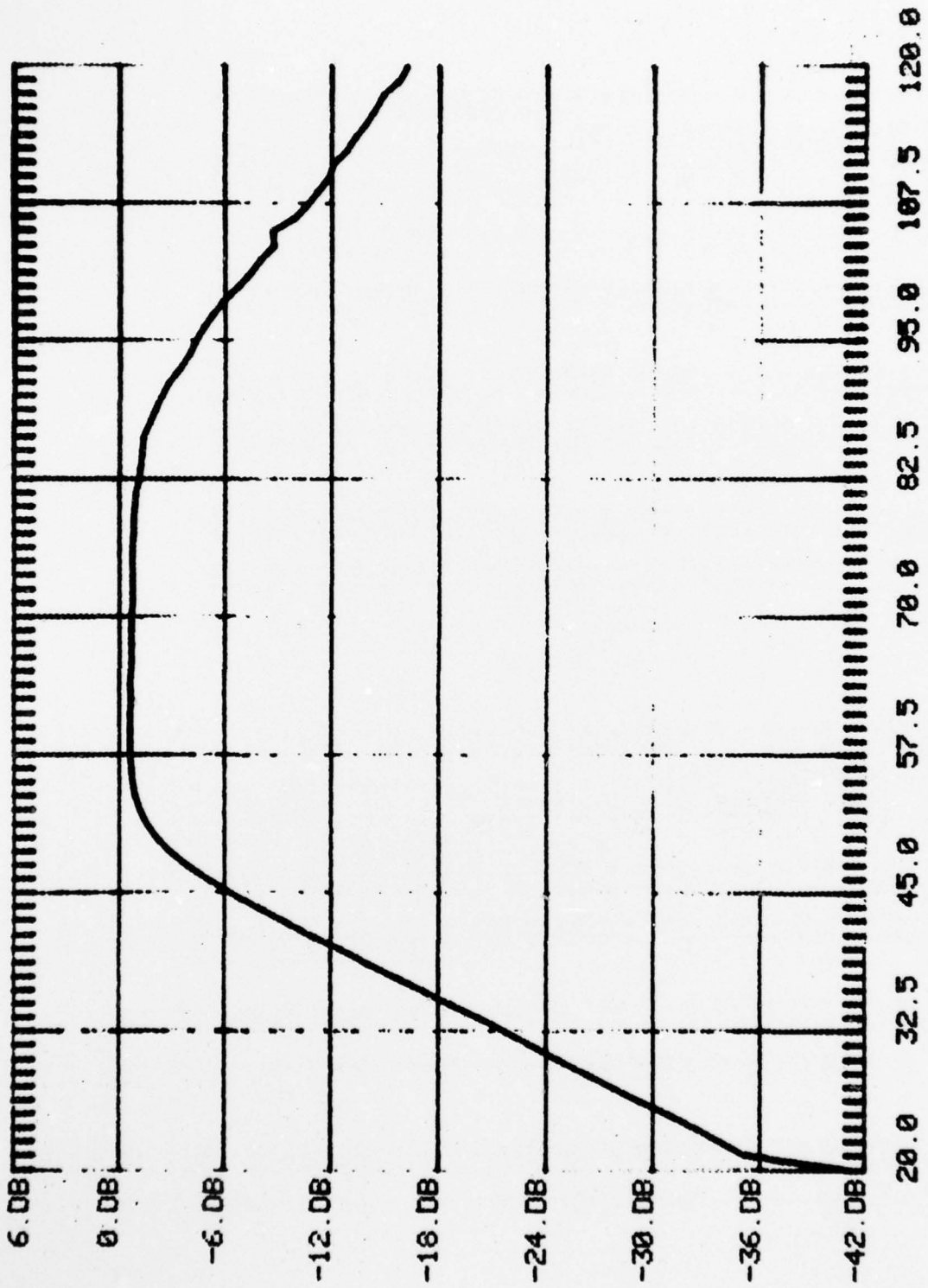

GAIN VS FREQUENCY IN MHZ

Channel B IF Filter Response Plot

FREQ. MHZ	GAIN DB	PHASE DEG	DELAY MICROSEC
0.00	-39.60	81.51	0.00
0.25	-8.47	-33.47	-371908*
0.50	-9.26	-79.83	-443522*
0.75	-9.34	-67.36	-249476*
1.00	-0.39	-56.57	-157132*
1.25	-0.36	-45.87	-101942*
1.50	-0.33	-34.18	-63295 *
1.75	-0.29	-22.41	-35574 *
2.00	-0.26	-11.45	-15903 *
2.25	-0.27	0.06	75.35
2.50	-0.31	11.12	12356.22
2.75	-0.41	21.94	22157.59
3.00	-0.57	33.90	31387.86
3.25	-0.79	45.35	38759.88
3.50	-1.09	56.51	44846.28
3.75	-1.35	68.18	50500.91
4.00	-1.70	80.11	55635.22
4.25	-2.13	91.66	59910.16
4.50	-2.62	103.31	63770.41
4.75	-3.17	114.51	66967.37
5.00	-4.00	125.60	69776.75
5.25	-4.68	136.29	72111.94
5.50	-5.52	146.96	74222.50
5.75	-6.40	157.43	76055.19
6.00	-7.36	167.20	77407.37
6.25	-8.31	176.72	78542.81
6.50	-9.31	185.88	79434.50
6.75	-10.32	-32.93	-13553.*
7.00	-11.34	-155.37	-61655.*
7.25	-12.46	-146.75	-56227.*
7.50	-13.51	-137.40	-50889.*
7.75	-14.64	-129.35	-46360.*
8.00	-15.69	-121.58	-42216.*
8.25			
8.50			
8.75			
9.00			
9.25			
9.50			
9.75			
10.00			
10.25			
10.50			
10.75			
11.00			
11.25			
11.50			
11.75			
12.00			
12.25			
12.50			
12.75			
13.00			
13.25			
13.50			
13.75			
14.00			
14.25			
14.50			
14.75			
15.00			
16.78			
19.39			
20.29			
21.14			
21.20			
22.16			
23.21			
24.62			
25.13			
25.93			
26.93			
27.73			
28.69			
29.36			
30.18			
31.18			
31.88			
32.75			
33.60			
34.53			
35.27			
36.07			
36.96			
37.74			
38.83			
39.81			
40.34			
41.21			
-114.67			
-108.35			
-100.90			
-95.78			
-88.60			
-83.18			
-78.08			
-73.19			
-70.21			
-64.48			
-60.08			
-55.96			
-52.64			
-49.93			
-46.26			
-42.90			
-38.75			
-35.30			
-31.62			
-27.61			
-24.00			
-20.09			
-16.99			
-13.82			
-8.67			
-7.98			
-5.13			
-2.42			
167.38610.*			
167.35408.*			
167.32032.*			
167.29560.*			
167.26606.*			
167.24321.*			
167.22244.*			
167.20331.*			
167.19028.*			
167.17038.*			
167.15525.*			
167.14130.*			
167.12996.*			
167.12059.*			
167.10937.*			
167.9929.55			
167.8785.77			
167.7845.09			
167.6888.09			
167.5900.09			
167.5031.26			
167.4134.33			
167.3432.78			
167.2741.75			
167.1689.48			
167.1529.39			
167.965.53			
167.447.59			

AI Partial Response Filter Response Table

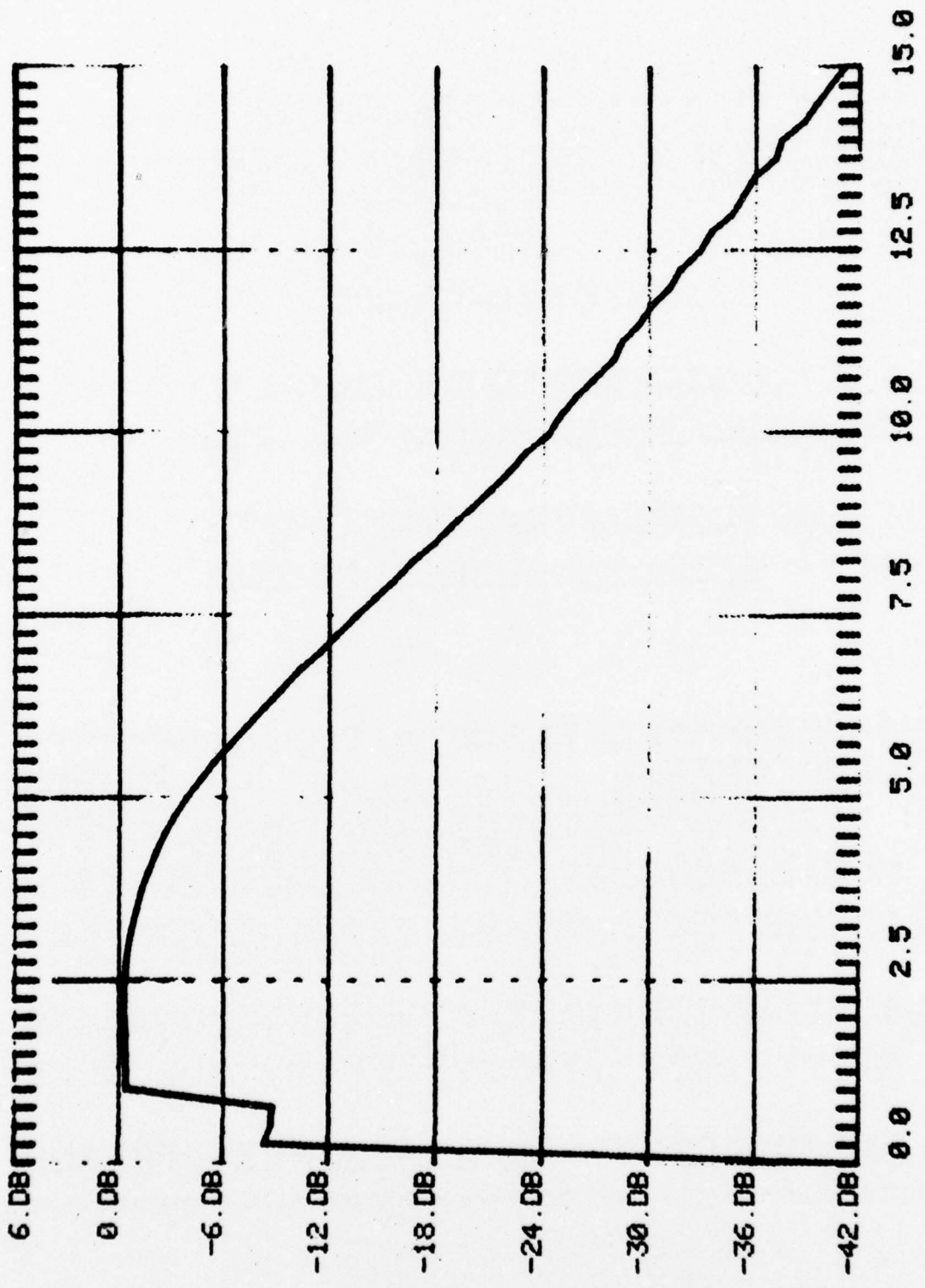

GAIN VS FREQUENCY IN MHZ

AI Partial Response Filter Response Plot

FREQ. MHC	GAIN DB	PHASE DEG.	DELAY MICROSEC
0.00	-38.60	81.51	0.00
0.25	-8.47	-33.47	371908*
0.50	-9.26	-79.83	443522*
0.75	-9.34	-67.36	249476*
1.00	-0.39	-56.57	157132*
1.25	-0.36	-45.87	101942*
1.50	-0.33	-34.18	63295 *
1.75	-0.29	-22.41	35574 *
2.00	-0.26	-11.45	15903 *
2.25	-0.27	0.06	75.35
2.50	-0.31	11.12	2356.22
2.75	-0.41	21.94	22157.59
3.00	-0.57	33.90	31387.86
3.25	-0.79	45.35	38759.88
3.50	-1.09	56.51	44846.28
3.75	-1.35	68.18	50500.91
4.00	-1.70	80.11	55635.22
4.25	-2.13	91.66	59910.16
4.50	-2.62	103.31	63770.41
4.75	-3.17	114.51	66967.37
5.00	-4.00	125.60	69776.75
5.25	-4.68	136.29	72111.94
5.50	-5.52	146.96	74222.50
5.75	-6.40	157.43	76055.19
6.00	-7.36	167.20	77487.37
6.25	-8.31	176.72	78542.81
6.50	-9.31	185.88	79434.50
6.75	-10.32	-32.93	13553.*
7.00	-11.34	-155.37	61655.*
7.25	-12.46	-146.75	56227.*
7.50	-13.51	-137.40	50889.*
7.75	-14.64	-129.35	46360.*
8.00	-15.69	-121.58	42216.*
8.25			
8.50			
8.75			
9.00			
9.25			
9.50			
9.75			
10.00			
10.25			
10.50			
10.75			
11.00			
11.25			
11.50			
11.75			
12.00			
12.25			
12.50			
12.75			
13.00			
13.25			
13.50			
13.75			
14.00			
14.25			
14.50			
14.75			
15.00			
16.78			
19.39			
19.29			
20.14			
21.20			
22.16			
23.21			
24.62			
25.13			
25.93			
26.93			
27.73			
28.69			
29.36			
30.18			
31.18			
31.88			
32.75			
33.60			
34.53			
35.27			
36.07			
36.96			
37.74			
38.83			
39.81			
40.34			
41.21			
-114.67			
-108.35			
-100.90			
-95.78			
-90.60			
-83.18			
-78.08			
-73.19			
-70.21			
-64.40			
-60.08			
-55.96			
-52.64			
-49.93			
-46.26			
-42.90			
-38.75			
-35.30			
-31.62			
-27.61			
-24.00			
-20.09			
-16.99			
-13.82			
-8.67			
-7.98			
-5.13			
-2.42			
127.38610.*			
135.400.*			
132032.*			
129560.*			
126606.*			
124321.*			
122244.*			
120331.*			
119028.*			
117038.*			
115525.*			
114130.*			
112996.*			
112059.*			
110937.*			
109929.55			
108785.77			
107845.09			
106888.09			
105900.09			
105031.26			
104134.33			
103432.78			
102741.75			
101689.48			
101529.39			
101965.53			
101447.59			

AQ Partial Response Filter Response Table

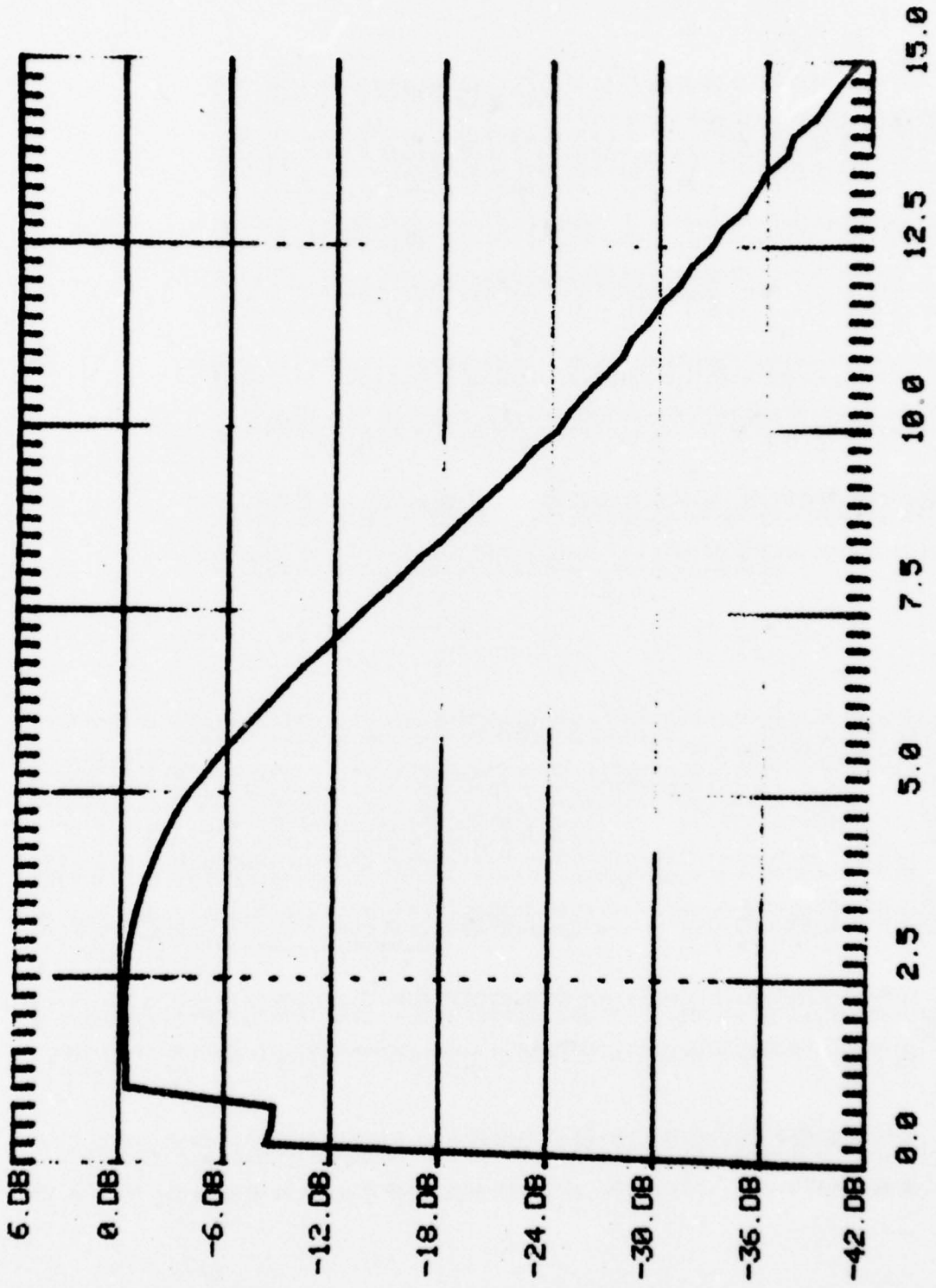

GAIN VS FREQUENCY IN MHZ

AQ Partial Response Filter Response Plot

FREQ. MHZ	GAIN DB	PHASE DEG.	DELAY MICROSEC
0.00	-38.60	81.51	0.00
0.25	-9.47	-33.47	371908*
0.50	-9.26	-79.83	443522*
0.75	-9.34	-67.36	249476*
1.00	-0.39	-56.57	157132*
1.25	-0.36	-45.87	101942*
1.50	-0.33	-34.18	63295 *
1.75	-0.29	-22.41	35574 *
2.00	-0.26	-11.45	15903 *
2.25	-0.27	0.06	75.35
2.50	-0.31	11.12	12356.22
2.75	-0.41	21.94	22157.59
3.00	-0.57	33.90	31387.86
3.25	-0.79	45.35	38759.88
3.50	-1.09	56.51	44846.28
3.75	-1.35	68.18	50500.91
4.00	-1.70	80.11	55635.22
4.25	-2.13	91.66	59910.16
4.50	-2.62	103.31	63770.41
4.75	-3.17	114.51	66967.37
5.00	-4.00	125.60	69776.75
5.25	-4.68	136.29	72111.94
5.50	-5.52	146.96	74222.50
5.75	-6.40	157.43	76055.19
6.00	-7.36	167.20	77407.37
6.25	-8.31	176.72	78542.81
6.50	-9.32	185.88	79434.50
6.75	-10.32	-32.93	13553.*
7.00	-11.34	-155.37	61655.*
7.25	-12.46	-146.75	56227.*
7.50	-13.51	-137.40	50889.*
7.75	-14.64	-129.35	46360.*
8.00	-15.69	-121.58	42216.*
0.25	-16.78	0.25	
0.50	-10.39	0.50	
0.75	-19.29	0.75	
0.90	-20.14	0.90	
0.95	-21.20	0.95	
1.00	-22.16	1.00	
1.05	-23.21	1.05	
1.10	-24.62	1.10	
1.15	-25.13	1.15	
1.20	-25.93	1.20	
1.25	-26.93	1.25	
1.30	-27.73	1.30	
1.35	-28.69	1.35	
1.40	-29.36	1.40	
1.45	-30.18	1.45	
1.50	-31.18	1.50	
1.55	-31.88	1.55	
1.60	-32.75	1.60	
1.65	-33.60	1.65	
1.70	-34.53	1.70	
1.75	-35.27	1.75	
1.80	-36.07	1.80	
1.85	-36.96	1.85	
1.90	-37.74	1.90	
1.95	-38.83	1.95	
2.00	-39.81	2.00	
2.05	-40.34	2.05	
2.10	-41.21	2.10	
2.15	-114.67	2.15	38610.*
2.20	-108.35	2.20	35408.*
2.25	-100.90	2.25	32032.*
2.30	-95.78	2.30	29560.*
2.35	-88.60	2.35	26606.*
2.40	-83.18	2.40	24321.*
2.45	-78.00	2.45	22244.*
2.50	-73.19	2.50	20331.*
2.55	-70.21	2.55	19028.*
2.60	-64.40	2.60	17038.*
2.65	-60.08	2.65	15525.*
2.70	-55.96	2.70	14130.*
2.75	-52.64	2.75	12996.*
2.80	-49.93	2.80	12059.*
2.85	-46.26	2.85	10937.*
2.90	-42.90	2.90	9929.55
2.95	-38.75	2.95	8785.77
3.00	-35.30	3.00	7845.09
3.05	-31.62	3.05	6888.09
3.10	-27.61	3.10	5900.09
3.15	-24.00	3.15	5031.26
3.20	-20.09	3.20	4134.33
3.25	-16.99	3.25	3432.78
3.30	-13.82	3.30	2741.75
3.35	-8.67	3.35	1689.48
3.40	-7.98	3.40	1529.39
3.45	-5.13	3.45	965.53
3.50	-2.42	3.50	447.59

BI Partial Response Filter Response Table

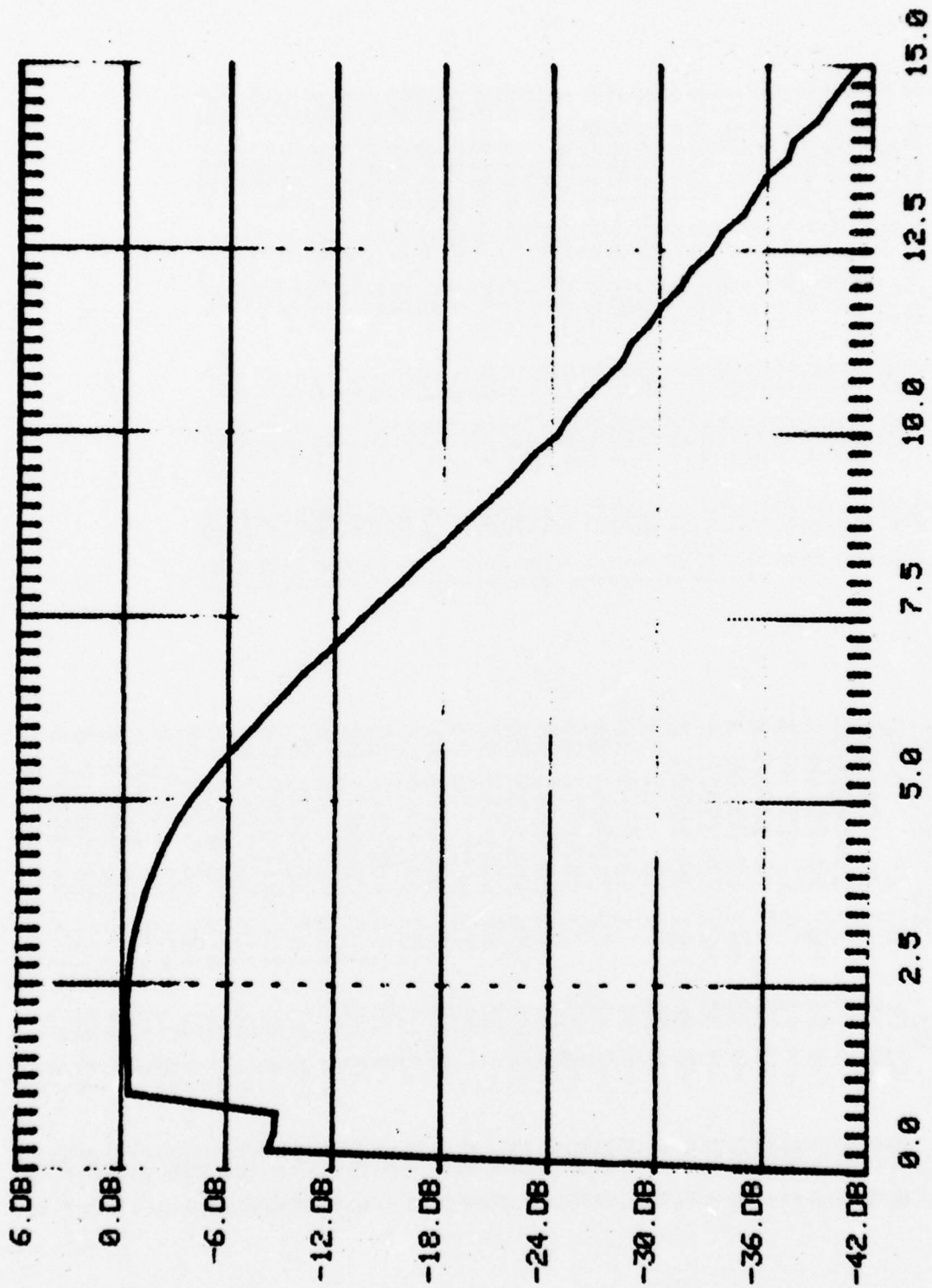

GAIN VS FREQUENCY IN MHZ

BI Partial Response Filter Response Plot

FREQ. MHZ	GAIN DB	PHASE DEG.	DELAY MICROSEC
0.00	-42.00	83.07	0.00
0.25	-8.33	-43.75	486111*
0.50	-8.74	-79.69	442708*
0.75	-8.81	-67.94	251646*
1.00	-0.41	-56.67	157403*
1.25	-0.37	-45.43	100966*
1.50	-0.32	-34.16	63250.*
1.75	-0.30	-22.73	36078.*
2.00	-0.26	-11.38	15801.*
2.25	-0.26	-0.10	-120.56
2.50	-0.31	11.10	12329.09
2.75	-0.42	22.81	23045.39
3.00	-0.56	33.83	31320.03
3.25	-0.77	45.23	38655.59
3.50	-1.04	56.95	45195.03
3.75	-1.33	67.88	50283.87
4.00	-1.71	79.68	55330.03
4.25	-2.13	91.30	59670.81
4.50	-2.61	103.28	63755.34
4.75	-3.18	114.69	67067.25
5.00	-3.85	125.70	69831.00
5.25	-4.70	136.83	72396.12
5.50	-5.54	147.35	74419.81
5.75	-6.41	157.21	75949.00
6.00	-7.38	166.93	77283.00
6.25	-8.33	176.53	78456.00
6.50	-9.31	186.46	79684.94
6.75	-10.33	-31.62	-13010.*
7.00	-11.49	-155.08	-61539.*
7.25	-12.44	-145.00	-55553.*
7.50	-13.50	-137.48	-50917.*
7.75	-14.58	-129.76	-46509.*
8.00	-15.70	-122.02	-42368.*
8.25			
8.50			
8.75			
9.00			
9.25			
9.50			
9.75			
10.00			
10.25			
10.50			
10.75			
11.00			
11.25			
11.50			
11.75			
12.00			
12.25			
12.50			
12.75			
13.00			
13.25			
13.50			
13.75			
14.00			
14.25			
14.50			
14.75			
15.00			
16.77			
17.98			
18.96			
20.08			
21.17			
22.23			
23.13			
24.35			
25.88			
26.93			
27.93			
28.48			
29.44			
30.09			
31.18			
31.77			
32.87			
33.47			
34.67			
35.27			
35.91			
37.15			
37.54			
38.83			
39.55			
40.34			
41.21			
-114.97			
-100.03			
-101.03			
-96.88			
-88.82			
-83.35			
-77.95			
-73.14			
-69.21			
-64.18			
-60.28			
-56.88			
-52.91			
-49.51			
-45.95			
-42.53			
-38.89			
-35.16			
-31.15			
-27.66			
-24.12			
-20.26			
-16.55			
-13.65			
-11.89			
-7.59			
-5.03			
-2.71			

BQ Partial Response Filter Response Table

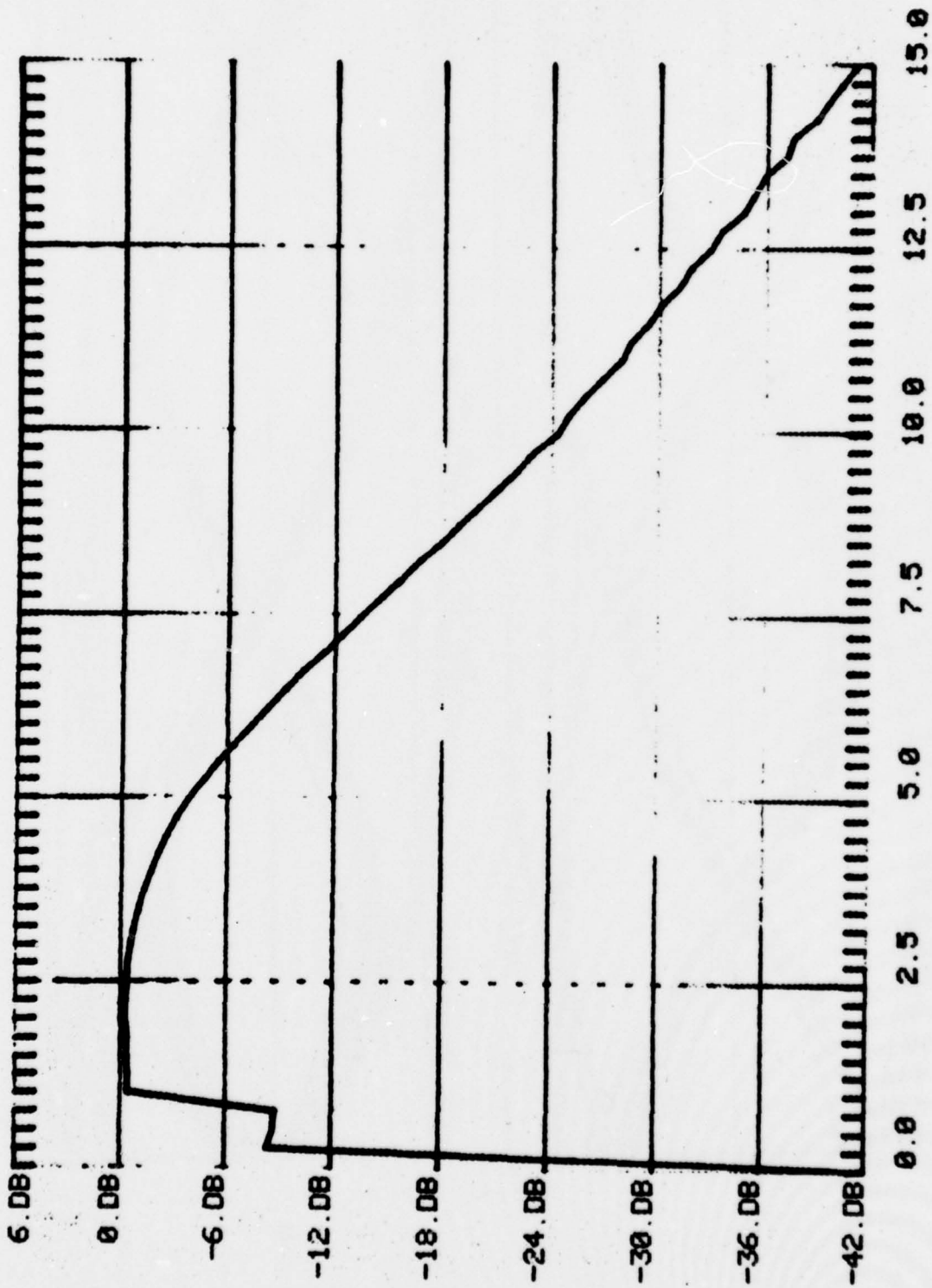

GAIN VS FREQUENCY IN MHZ

BQ Partial Response Filter Response Plot

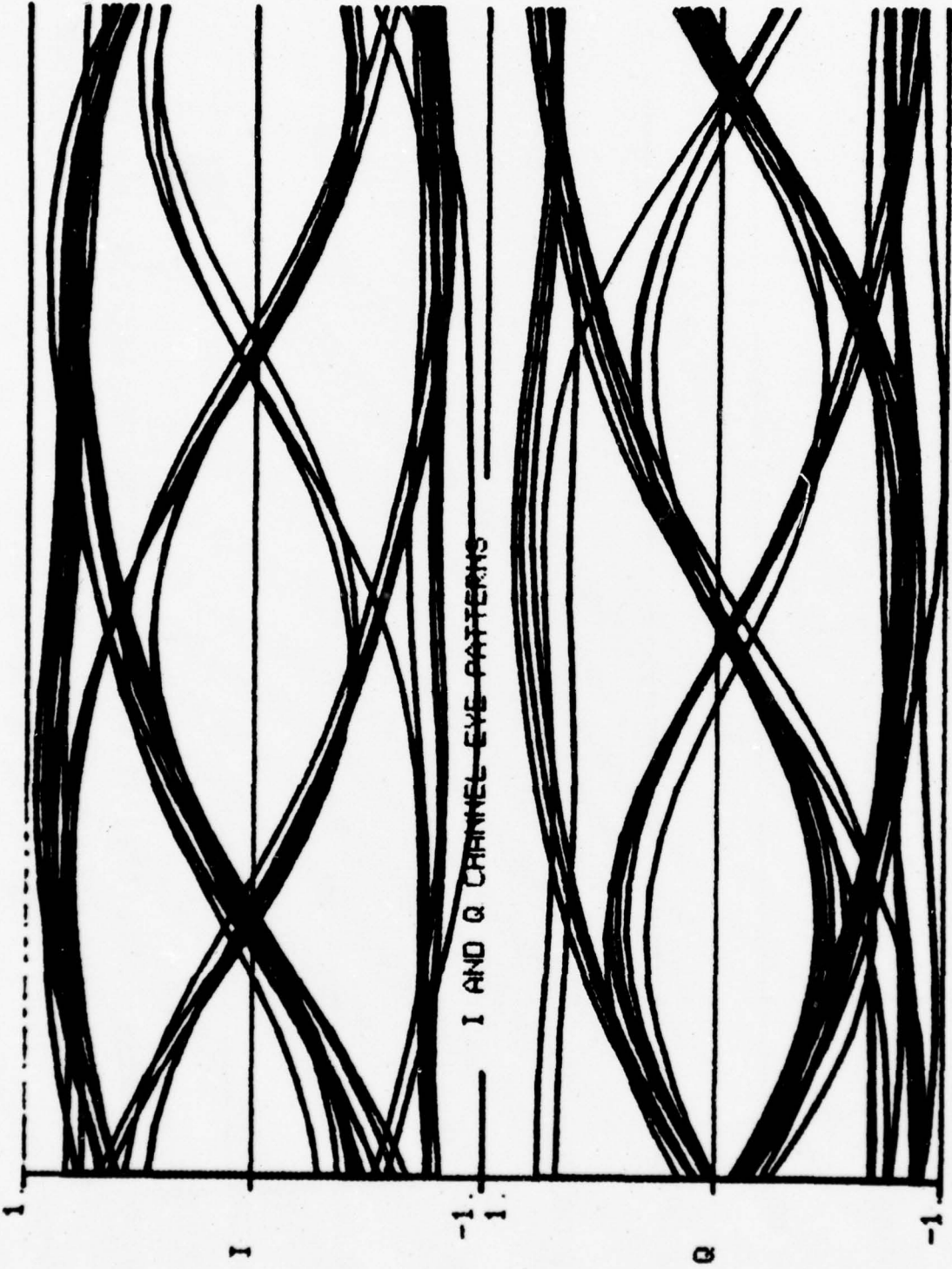

QPR Eye Pattern

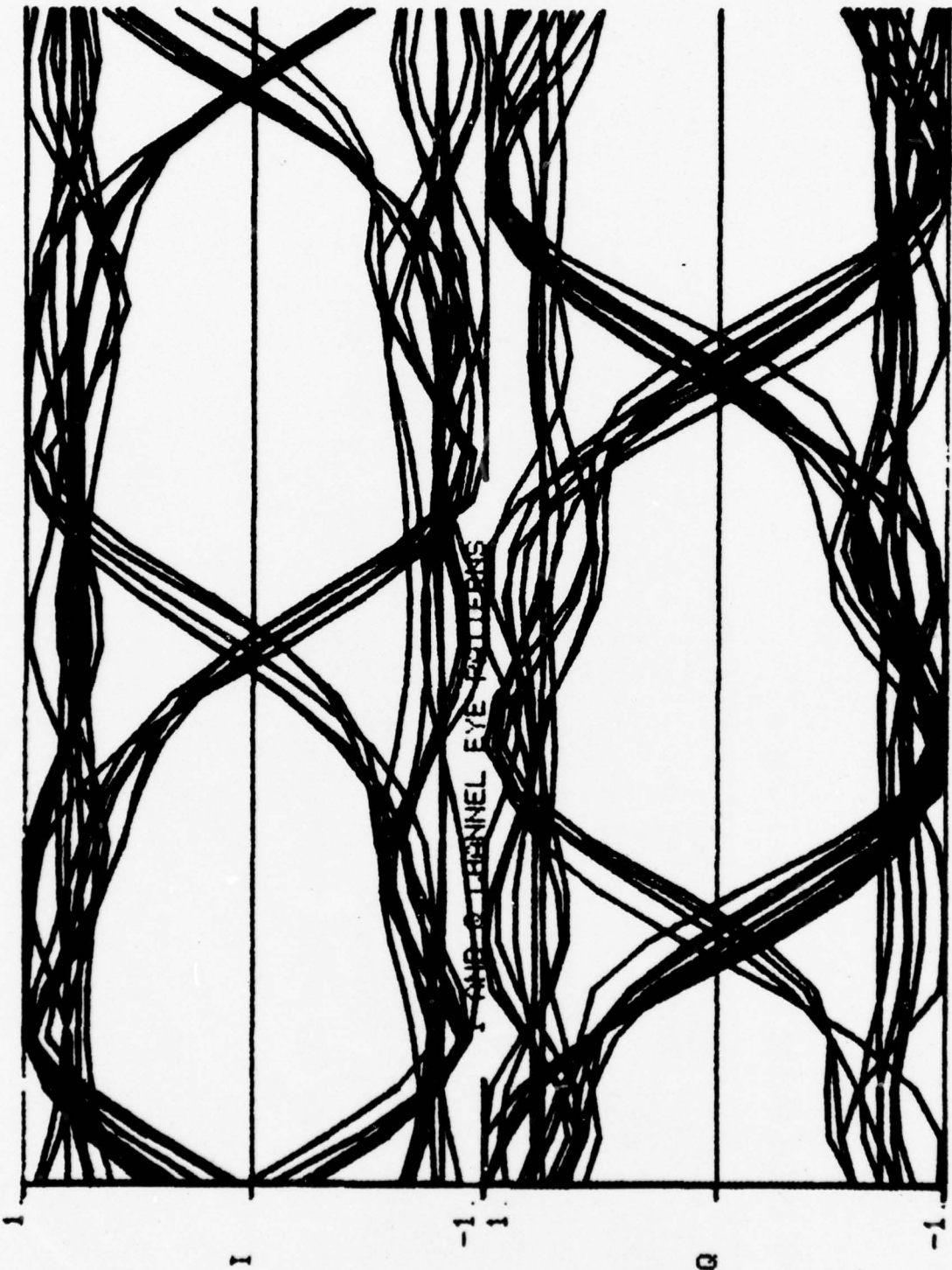

QPSK Eye Pattern

ENTER CHANNEL CONFIGURATION

- 1. RAYLEIGH
- 2. TROPOSCATTER
- 3. OUT
- 4. LOS

3. TO INPUT NOISE TYPE 1, NO 0

SELECT THE DIVERSITY SWITCH CONTROL FROM

- AGC QUALITY MONITOR .. TYPE 1
- EYE QUALITY MONITOR .. TYPE 2
- TEST A ONLY TYPE 3
- TEST B ONLY TYPE 4

2. TO ALTER EYE QUALITY MONITOR TYPE 1, NO 0

ENTER RUN TIME XXX.X SEC.
120.

TOTAL BITS =	120015.			
CHANNEL A BIT ERRORS =		0.	BER =	0.00E	01
CHANNEL B BIT ERRORS =		0.	BER =	0.00E	01
DIVERSITY BIT ERRORS =		0.	BER =	0.00E	01

FOR ANOTHER BIT ERROR TEST TYPE 1, NO 0

QPR Bit Error Test - No Noise

ENTER CHANNEL CONFIGURATION

- 1. RAYLEIGH
- 2. TROPOSCATTER
- 3. OUT
- 4. LOS

3. TO INPUT NOISE TYPE 1, NO 0

1. WHAT EB/NO RATIO WOULD YOU LIKE

10. SELECT THE DIVERSITY SWITCH CONTROL FROM

- AGC QUALITY MONITOR . . . TYPE 1
- EYE QUALITY MONITOR . . . TYPE 2
- TEST A ONLY TYPE 3
- TEST B ONLY TYPE 4

2. TO ALTER EYE QUALITY MONITOR TYPE 1, NO 0

ENTER RUN TIME XXX.X SEC.

300. TOTAL BITS = 300024. BER = 0.37E-02
CHANNEL A BIT ERRORS = 1123. BER = 0.42E-02
CHANNEL B BIT ERRORS = 1258. BER = 0.37E-02
DIVERSITY BIT ERRORS = 1118.

FOR ANOTHER BIT ERROR TEST TYPE 1, NO 0

ENTER CHANNEL CONFIGURATION

- 1. RAYLEIGH
- 2. TROPOSCATTER
- 3. OUT
- 4. LOS

3. TO INPUT NOISE TYPE 1, NO 0

1. WHAT EB/NO RATIO WOULD YOU LIKE

12. SELECT THE DIVERSITY SWITCH CONTROL FROM

- AGC QUALITY MONITOR . . . TYPE 1
- EYE QUALITY MONITOR . . . TYPE 2
- TEST A ONLY TYPE 3
- TEST B ONLY TYPE 4

2. TO ALTER EYE QUALITY MONITOR TYPE 1, NO 0

ENTER RUN TIME XXX.X SEC.

300. TOTAL BITS = 300024. BER = 0.49E-03
CHANNEL A BIT ERRORS = 146. BER = 0.71E-03
CHANNEL B BIT ERRORS = 214. BER = 0.57E-03
DIVERSITY BIT ERRORS = 172.

FOR ANOTHER BIT ERROR TEST TYPE 1, NO 0

ENTER CHANNEL CONFIGURATION

- 1. RAYLEIGH
- 2. TROPOSCATTER
- 3. OUT
- 4. LOS

3. TO INPUT NOISETYPE 1, NO 0

1. WHAT EB/NO RATIO WOULD YOU LIKE

14. SELECT THE DIVERSITY SWITCH CONTROL FROM

- AGC QUALITY MONITOR ..TYPE 1
- EYE QUALITY MONITOR ..TYPE 2
- TEST A ONLYTYPE 3
- TEST B ONLYTYPE 4

2. TO ALTER EYE QUALITY MONITOR TYPE 1, NO 0

ENTER RUN TIME XXX.X SEC.

300.

TOTAL BITS = 300024.

CHANNEL A BIT ERRORS =

CHANNEL B BIT ERRORS =

DIVERSITY BIT ERRORS =

BER = 0.67E-05

BER = 0.67E-05

BER = 0.10E-04

FOR ANOTHER BIT ERROR TEST TYPE 1, NO 0

ENTER CHANNEL CONFIGURATION

1. RAYLEIGH
2. TROPOSCATTER
3. OUT
4. LOS

3 TO INPUT NOISE TYPE 1, NO 0

SELECT THE DIVERSITY SWITCH CONTROL FROM

- AGC QUALITY MONITOR . . . TYPE 1
EYE QUALITY MONITOR . . . TYPE 2
TEST A ONLY TYPE 3
TEST B ONLY TYPE 4

2 TO ALTER EYE QUALITY MONITOR TYPE 1, NO 0

ENTER RUN TIME XXX X SEC.
120.

TOTAL BITS = 120015. BER = 0.00E 01
CHANNEL A BIT ERRORS = 0. BER = 0.00E 01
CHANNEL B BIT ERRORS = 0. BER = 0.00E 01
DIVERSITY BIT ERRORS = 0. BER = 0.00E 01

FOR ANOTHER BIT ERROR TEST TYPE 1, NO 0

QPSK Bit Error Test - No Noise

ENTER CHANNEL CONFIGURATION

- 1. RAYLEIGH
- 2. TROPOSCATTER
- 3. OUT
- 4. LOS

3. TO INPUT NOISE TYPE 1, NO 0

10. WHAT EB/NO RATIO WOULD YOU LIKE

SELECT THE DIVERSITY SWITCH CONTROL FROM

- AGC QUALITY MONITOR . . . TYPE 1
- EYE QUALITY MONITOR . . . TYPE 2
- TEST A ONLY TYPE 3
- TEST B ONLY TYPE 4

2. TO ALTER EYE QUALITY MONITOR TYPE 1, NO 0

ENTER RUN TIME XXX.X SEC.

TOTAL BITS = 300024.

CHANNEL A BIT ERRORS = 574.

CHANNEL B BIT ERRORS = 446.

DIVERSITY BIT ERRORS = 471.

BER = 0.19E-02
BER = 0.15E-02
BER = 0.16E-02

FOR ANOTHER BIT ERROR TEST TYPE 1, NO 0

ENTER CHANNEL CONFIGURATION

- 1. RAYLEIGH
- 2. TROPOSCATTER
- 3. QUT
- 4. LOS

3 TO INPUT NOISE TYPE 1, NO 0

1 WHAT EB/NO RATIO WOULD YOU LIKE

12. SELECT THE DIVERSITY SWITCH CONTROL FROM

- AGC QUALITY MONITOR . . . TYPE 1
- EYE QUALITY MONITOR . . . TYPE 2
- TEST A ONLY TYPE 3
- TEST B ONLY TYPE 4

2 TO ALTER EYE QUALITY MONITOR TYPE 1, NO 0

ENTER RUN TIME XXX.X SEC.

300.

TOTAL BITS = 300024.

CHANNEL A BIT ERRORS =

CHANNEL B BIT ERRORS =

DIVERSITY BIT ERRORS =

36.

48.

41.

BER =

BER =

BER =

0.12E-03

0.16E-03

0.14E-03

FOR ANOTHER BIT ERROR TEST TYPE 1, NO 0

QPSK Bit Error Test - 12 dB Eb/No

ENTER CHANNEL CONFIGURATION

- 1. RAYLEIGH
- 2. TROPOSCATTER
- 3. OUT
- 4. LOS

3 TO INPUT NOISE TYPE 1, NO 0

1 WHAT EB/NO RATIO WOULD YOU LIKE

14 SELECT THE DIVERSITY SWITCH CONTROL FROM
AGC QUALITY MONITOR . . . TYPE 1
EYE QUALITY MONITOR . . . TYPE 2
TEST A ONLY TYPE 3
TEST B ONLY TYPE 4

2 TO ALTER EYE QUALITY MONITOR TYPE 1, NO 0

ENTER RUN TIME XXX.X SEC.

300.

TOTAL BITS = 300024.

CHANNEL A BIT ERRORS =

CHANNEL B BIT ERRORS =

DIVERSITY BIT ERRORS =

BER = 0.13E-04
BER = 0.67E-05
BER = 0.67E-05

FOR ANOTHER BIT ERROR TEST TYPE 1, NO 0

ENTER CHANNEL CONFIGURATION

- 1. RAYLEIGH
- 2. TROPOSCATTER
- 3. OUT
- 4. LOS

1 ENTER FACE RATE ... 1 HZ MAXIMUM
01 TO INPUT NOISE ... TYPE 1, NO 0

0 SELECT THE DIVERSITY SWITCH CONTROL FROM
EYE QUALITY MONITOR ... TYPE 1
EYE QUALITY MONITOR ... TYPE 2
TEST A ONLY ... TYPE 3
TEST B ONLY ... TYPE 4

2 TO ALTER EYE QUALITY MONITOR TYPE 1, NO 0
0

ENTER RUN TIME XXX.X SEC.
600

TOTAL BITS =	600049		
CHANNEL A BIT ERRORS =	0	BER =	0.00E 01
CHANNEL B BIT ERRORS =	32	BER =	0.53E-04
DIVERSITY BIT ERRORS =	1	BER =	0.17E-05

FOR ANOTHER BIT ERROR TEST TYPE 1, NO 0

QPSK Bit Error Test - Rayleigh No Noise

ENTER CHANNEL CONFIGURATION

- 1. RAYLEIGH
- 2. TROPOSCATTER
- 3. OUT
- 4. LOS

2. FOR A DELAY PROFILE TYPE 1, NO 0
1

Troposcatter Channel Option

ENTER PATH LENGTH IN MILES
250250 000

IF THIS IS A SMOOTH EARTH PATH TYPE 1, NO 0

1
ENTER EFFECTIVE EARTH (K).
1 33 1 330

ENTER ANTENNA BEAMWIDTHS IN DEGREES
BEAMWIDTH A = XX.X

8
BEAMWIDTH B = XX.X
8 0 800
8 0 800

DELAY USEC	POWER	AMPLITUDE
0 071	2273XE 00	4768XE 00
0 142	2033XE 00	4508XE 00
0 213	1238XE 00	3519XE 00
0 284	6377XE-01	2525XE 00
0 355	2912XE-01	1706XE 00
0 426	1324XE-01	1150XE 00
0 497	5514XE-02	7425XE-01
0 568	2389XE-02	4888XE-01
0 639	9894XE-03	3145XE-01
0 710	4024XE-03	2006XE-01
0 781	1667XE-03	1291XE-01
0 852	6528XE-04	8080XE-02

DO YOU WANT ANOTHER PATH. 1= YES, 0= NO.

1
TO GET A PROFILE PLOT TYPE 1, NO 0

Troposcatter Channel Profile

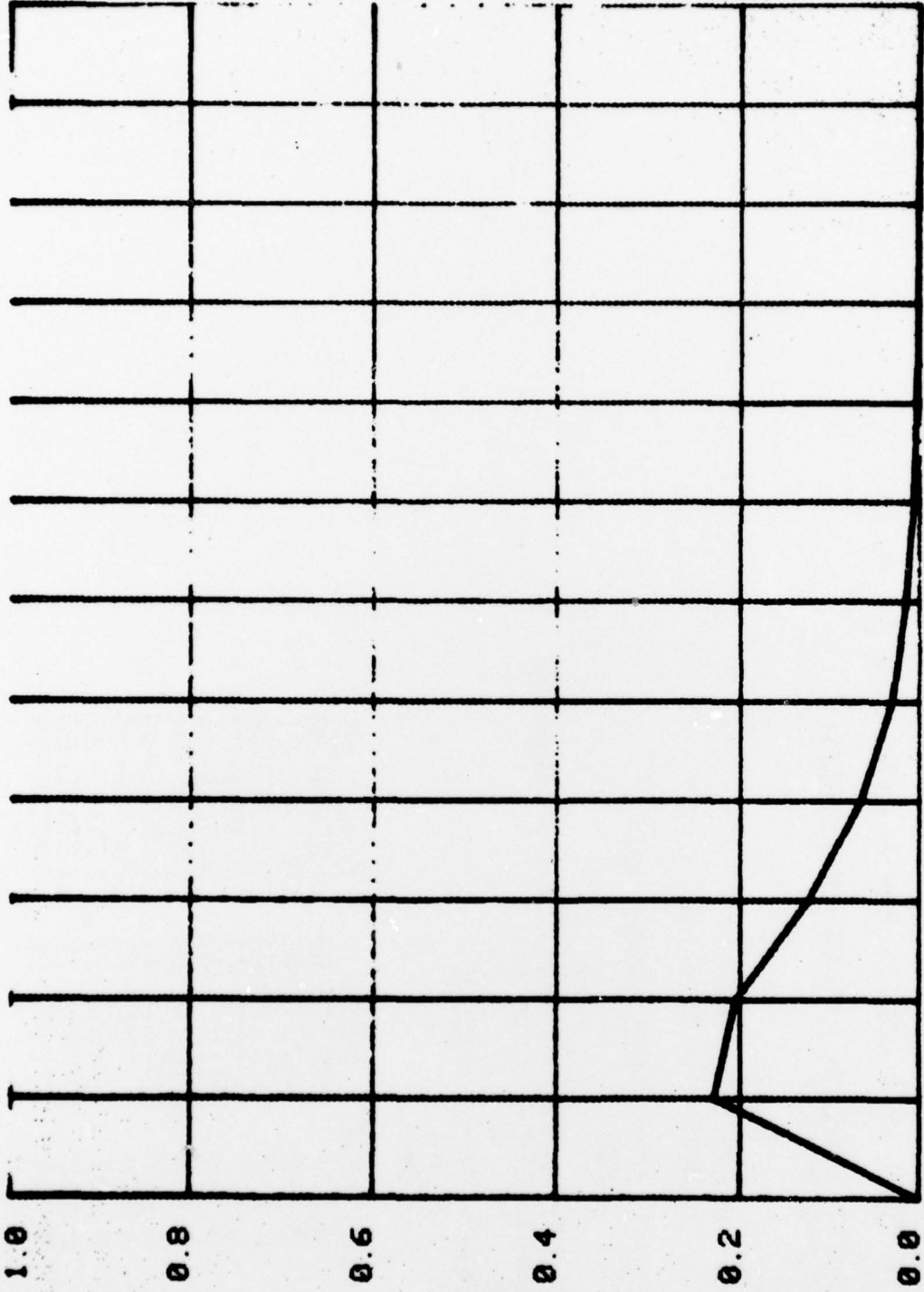

0.0 71.0 142.0 213.0 284.0 355.0 426.0 497.0 568.0 639.0 710.0 781.0 852

POWER VS DELAY IN NSEC.

Troposcatter Channel Profile Plot

0.852 .1358xE-20 .3686xE-10

ENTER PATH LENGTH IN MILES
150150 000

DO YOU WANT ANOTHER PATH. 1= YES, 0=
NO

IF THIS IS A SMOOTH EARTH PATH TYPE 1, NO 0

ENTER HORIZON ANGLES IN DEGREES

ALPHA = XX.X

8

BETA = XX.X

8 0.800

0.800

ENTER EFFECTIVE EARTH (K).

1.33 1.330

ENTER ANTENNA BEAMWIDTHS IN DEGREES

BEAMWIDTH A = XX.X

6

BEAMWIDTH B = XX.X

6 0.600

0.600

DELAY USEC	POWER	AMPLITUDE
0.071	5725xE 00	7566xE 00
0.142	7875xE-02	8874xE-01
0.213	5714xE-04	7559xE-02
0.284	1278xE-05	1130xE-02
0.355	8117xE-08	9009xE-04
0.426	2322xE-09	1523xE-04
0.497	2572xE-11	1603xE-05
0.568	4220xE-13	2054xE-06
0.639	8746xE-15	2957xE-07
0.710	7490xE-17	2736xE-08
0.781	2010xE-18	4483xE-09

Troposcatter Channel Profile

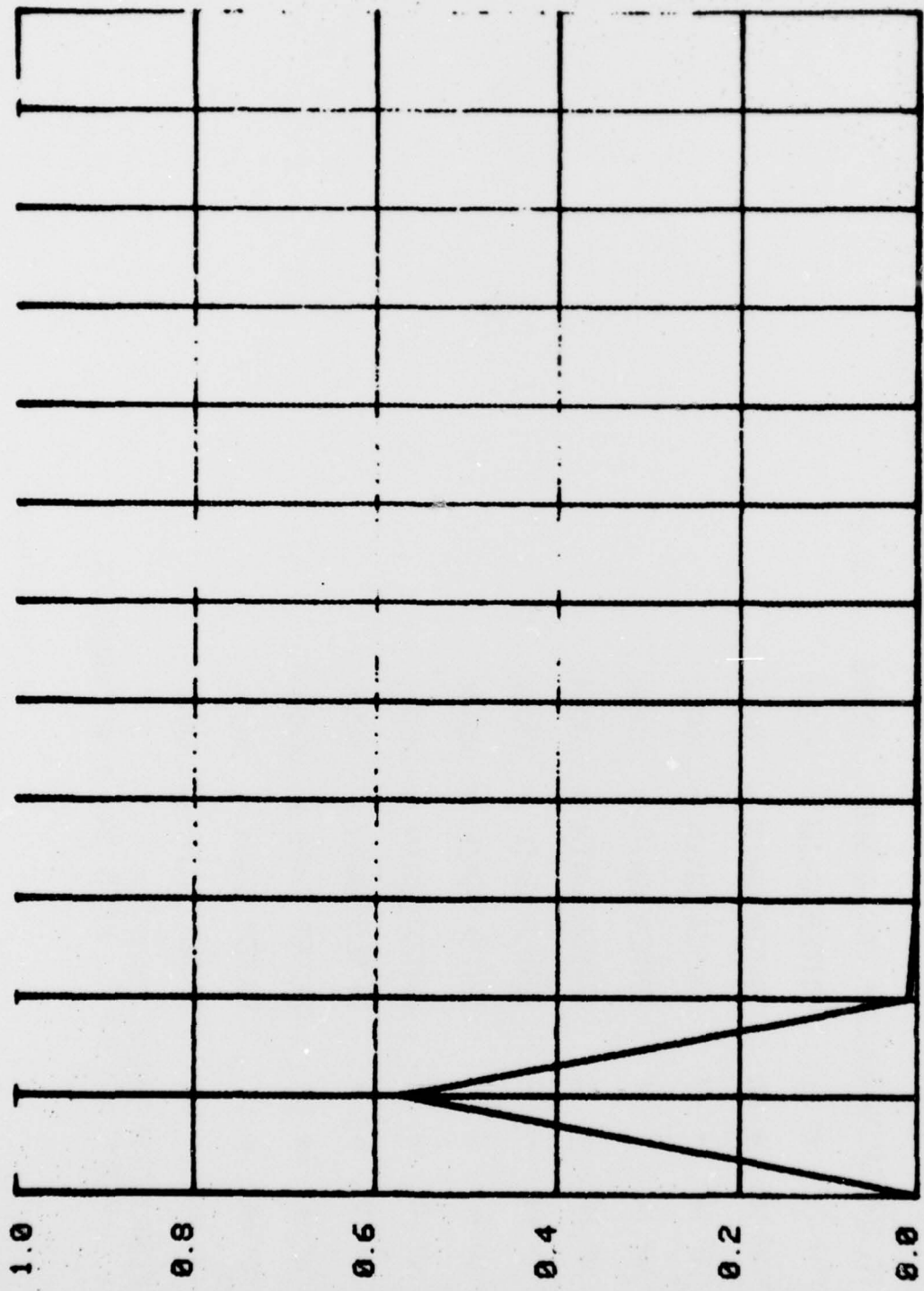

0.0 71.0 142.0 213.0 284.0 355.0 426.0 497.0 568.0 639.0 710.0 781.0 852

POWER VS DELAY IN NSEC.

Troposcatter Channel Profile Plot

5

ENTER CHANNEL CONFIGURATION

- 1. RAYLEIGH
- 2. TROPOSCATTER
- 3. OUT
- 4. LOS

SET SYNTHESIZER TO 2.048000 MHZ

TO GET A PROFILE PLOT TYPE 1, NO 0

4 TO ENTER MANUALLY TAP GAINS ... TYPE 1, NO 0

- 1 TAP NO. = 1 ENTER GAIN = .XXXX
- 6 TAP NO. = 2 ENTER GAIN = .XXXX
- 9 TAP NO. = 3 ENTER GAIN = .XXXX
- 8 TAP NO. = 4 ENTER GAIN = .XXXX
- 7 TAP NO. = 5 ENTER GAIN = .XXXX
- 6 TAP NO. = 6 ENTER GAIN = .XXXX
- 5 TAP NO. = 7 ENTER GAIN = .XXXX
- 4 TAP NO. = 8 ENTER GAIN = .XXXX
- 3 TAP NO. = 9 ENTER GAIN = .XXXX
- 2 TAP NO. = 10 ENTER GAIN = .XXXX
- 1 TAP NO. = 11 ENTER GAIN = .XXXX
- 01 TAP NO. = 12 ENTER GAIN = .XXXX
- 0

SELECT TAP DELAY SPACING
 FROM .25 TO 2. BITS IN .1 INCREMENTS

LOS Channel Option

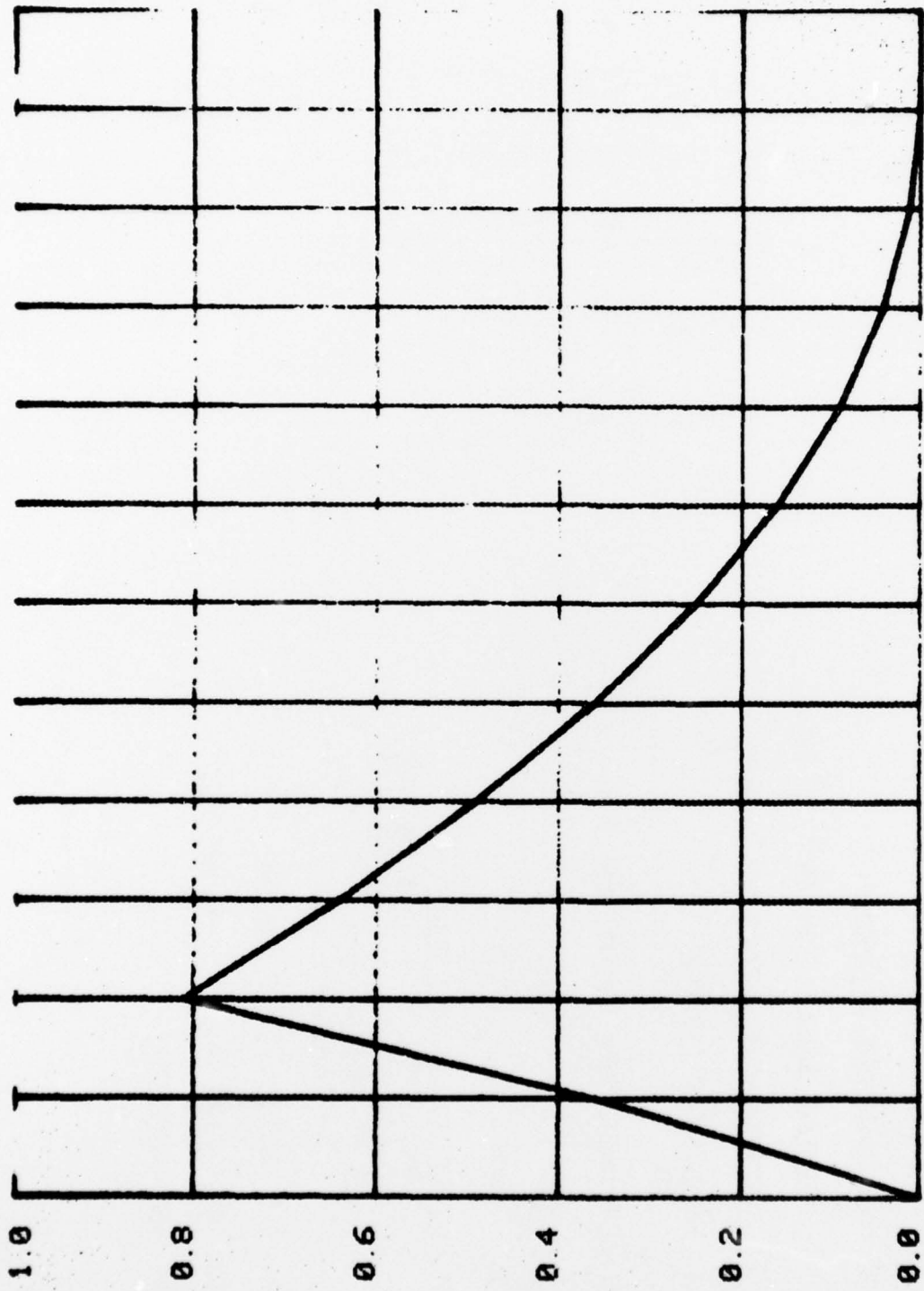

0.0 71.0 142.0 213.0 284.0 355.0 426.0 497.0 568.0 639.0 710.0 781.0 852

POWER VS DELAY IN NSEC.

LOS Channel Profile Plot

TO ALTER THE SYSTEM TYPE 1, NO 0

SYSTEM CONFIGURATION

1 RUN NUMBER = 0.0000

3. TRANSMITTER FILTERS
BEFORE NONLINEARITY . . . IN
AFTER NONLINEARITY . . . OUT

4. NONLINEAR DEVICE
IN

5. CHANNEL CONFIGURATION
1. RAYLEIGH

6. AGC
OUT

7. RECEIVER IF FILTERS
BANDWIDTH = -0.00 MHZ
CENTER FREQ. = -0.00 MHZ
NO OF POLES = 1
1. BUTTERWORTH

9. S/N RATIO = -0.00 DB

13. RUN TIME = -0.00 SEC

14. SCRAMBLER
IN

System Configuration List

APPENDIX F

ABBREVIATIONS AND ACRONYMS

ABC	- Analog Baseband Combiner
ABE	- Adaptive Backward Equalizer
ACAS	- Automatic Central Alarm System
ACOC	- Area Communications Operations Center
A/D	- Analog to Digital Switch
ADFE	- Adaptive Decision Feedback Equalizer
AFE	- Adaptive Forward Equalizer
AGC	- Automatic Gain Control
ATB	- All-Trunks-Busy
ATEC	- Automatic Technical Control
AUTODIN	- Automatic Digital Network
AUTOSEVOCOM	- Automatic Secure Voice Communication
AUTOVON	- Automatic Voice Network
BEC	- Backward Equalizer Channel
CCD	- Charge Coupled Device
CRD	- Channel Reassignment Diagram
CRM	- Channel Reassignment Module
CSL	- Computational Sciences Laboratory
D/A	- Digital-to-Analog Switch
DAR	- Distortion Adaptive Receiver
DAU	- Digital Applique Unit
DCAOC	- Defense Communications Agency Operations Center
DCS	- Defense Communications System
DRAMA	- Digital Radio and Multiplexer Application
DSCS	- Defense Satellite Communication System
DTMF	- Dual Tone Multifrequency
FEE	- Forward Equalizer Error
FED	- Forward Equalizer Delay
FEP	- Forward Equalizer Processor
FDM	- Frequency Division Multiplex
GOS	- Grade of Service
IF	- Intermediate Frequency
LOS	- Line of Sight
MBC	- Megahertz Baseband Converter
MFV	- Multifrequency Transceiver
NCS	- Node Control Subsystem
NCE	- Network Control Element
NRZ	- Nonreturn to Zero
OOS	- Out of Service
PLL	- Phase-Locked Loop

PMB	- Pilot-Make-Busy
PSD	- Power Spectral Density
PSK	- Phase Shift Keyed
QPR	- Quadrature Partial Response
QPSK	- Quadrature Phase Shift Keyed
RF	- Radio Frequency
RMS	- Root Mean Square
RPV	- Routing Plan Verifier
RSJ	- Register Sender Junctor
RSL	- Received Signal Level
RTAC	- Real-Time Adaptive Control
SNR	- Signal-to-Noise Ratio
SOS	- Speed of Service
TCE	- Terminal Control Element
TCR	- Touch Call Receivers
TDCS	- Traffic Data Collection System
TTD	- Time Tracking Detector
TTF	- Time Tracker Digital Filter
TTS	- Time Tracker Phase Shifter
TUR	- Traffic Usage Recorder
VCO	- Voltage Control Oscillator