

AD-A067 544

AIR FORCE MATERIALS LAB WRIGHT-PATTERSON AFB OHIO  
INTRODUCTION TO COMPOSITE MATERIALS. VOLUME I. DEFORMATION OF U--ETC(U)  
JAN 79 S W TSAI, H T HAHN  
AFML-TR-78-201-VOL-1

F/G 11/4

UNCLASSIFIED

NL

1 of 3  
ADA  
067544



**A067544**

**AFML-TR-78-201  
Volume I**

**LEVEL III**

**2**

**INTRODUCTION TO COMPOSITE MATERIALS**

**Volume I: Deformation of Unidirectional and Laminated Composites**

*STEPHEN W. TSAI  
H. THOMAS HAHN*

*MECHANICS AND SURFACE INTERACTIONS BRANCH  
NONMETALLIC MATERIALS DIVISION*

**JANUARY 1979**

**DDC FILE COPY**

**DDC**  
**APR 9 1979**  
**RECEIVED**

**TECHNICAL REPORT AFML-TR-78-201, Volume I**

**Approved for public release; distribution unlimited.**

**AIR FORCE MATERIALS LABORATORY  
AIR FORCE WRIGHT AERONAUTICAL LABORATORIES  
AIR FORCE SYSTEMS COMMAND  
WRIGHT-PATTERSON AIR FORCE BASE, OHIO 45433**

**79 04 05 025**

**NOTICE**

When Government drawings, specifications, or other data are used for any purpose other than in connection with a definitely related Government procurement operation, the United States Government thereby incurs no responsibility nor any obligation whatsoever; and the fact that the government may have formulated, furnished, or in any way supplied the said drawings, specifications, or other data, is not to be regarded by implication or otherwise as in any manner licensing the holder or any other person or corporation, or conveying any rights or permission to manufacture, use, or sell any patented invention that may in any way be related thereto.

This report has been reviewed by the Information Office (OI) and is releasable to the National Technical Information Service (NTIS). At NTIS, it will be available to the general public, including foreign nations.

This technical report has been reviewed and is approved for publication.

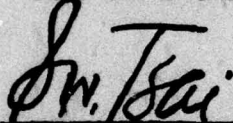

S. W. TSAI, Chief  
Mechanics & Surface Interactions Branch  
Nonmetallic Materials Division

FOR THE COMMANDER

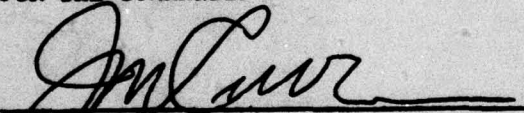

J. M. KELBLE, Chief  
Nonmetallic Materials Division

"If your address has changed, if you wish to be removed from our mailing list, or if the addressee is no longer employed by your organization please notify AFML/MBM, W-PAFB, OH 45433 to help us maintain a current mailing list".

Copies of this report should not be returned unless return is required by security considerations, contractual obligations, or notice on a specific document.

62102 F

UNCLASSIFIED

SECURITY CLASSIFICATION OF THIS PAGE (When Data Entered)

REPORT DOCUMENTATION PAGE		READ INSTRUCTIONS BEFORE COMPLETING FORM
1. REPORT NUMBER <b>14</b> AFML-TR-78-201 <u>Vol 1</u>	2. GOVT ACCESSION NO.	3. RECIPIENT'S CATALOG NUMBER
4. TITLE (and Subtitle) INTRODUCTION TO COMPOSITE MATERIALS VOLUME ONE: Deformation of Unidirectional and Laminated Composites	5. TYPE OF REPORT & PERIOD COVERED Interim 3-1-78--12-1-78	
7. AUTHOR(s) <b>10</b> Stephen W. Tsai and H. Thomas Hahn	6. PERFORMING ORG. REPORT NUMBER	
9. PERFORMING ORGANIZATION NAME AND ADDRESS Air Force Materials Laboratory Air Force Wright Aeronautical Laboratories (AFSC) Wright-Patterson AFB, Ohio 45433	10. PROGRAM ELEMENT, PROJECT, TASK AREA & WORK UNIT NUMBERS <b>16</b> 24190310 <b>17</b> 03	
11. CONTROLLING OFFICE NAME AND ADDRESS Air Force Materials Laboratory (AFML/MBM) Air Force Wright Aeronautical Laboratories Wright-Patterson AFB, Ohio 45433	12. REPORT DATE <b>11</b> January 1979	13. NUMBER OF PAGES 188
14. MONITORING AGENCY NAME & ADDRESS (if different from Controlling Office) <b>9</b> Interim Rept. 1 Mar - 1 Dec 78	15. SECURITY CLASS. (of this report) UNCLASSIFIED	
16. DISTRIBUTION STATEMENT (of this Report)  Approved for public release; distribution unlimited.		
17. DISTRIBUTION STATEMENT (of the abstract entered in Block 20, if different from Report) <b>12</b> 202 p <b>6</b> Introduction to Composite Materials, Volume I, Deformation of Unidirectional and Laminated Composites.		
18. SUPPLEMENTARY NOTES		
19. KEY WORDS (Continue on reverse side if necessary and identify by block number) Composite materials; elastic properties; stress; strain; stress-strain relations, transformation relations; modulus; compliance; engineering constants; laminated composites; in-plane properties, flexural properties; honeycomb cores.		
20. ABSTRACT (Continue on reverse side if necessary and identify by block number) This volume is intended to provide the basic derivations of equations needed for the elastic behavior of unidirectional and laminated composites. The modulus and compliance as functions of ply properties, angle of orientations, and stacking sequence of facing materials are all derived and shown in matrix multiplication tables. The only prerequisite for this volume is a course in strength of materials. All derivations are done in algebra. Matrix		

DD FORM 1473 1 JAN 73 EDITION OF 1 NOV 68 IS OBSOLETE

UNCLASSIFIED

SECURITY CLASSIFICATION OF THIS PAGE (When Data Entered)

79 04 05 025

012 320 alt

**UNCLASSIFIED**

**SECURITY CLASSIFICATION OF THIS PAGE(When Data Entered)**

and tensor operations are not used. Numerical examples are provided to illustrate the equations and their applications.



**UNCLASSIFIED**

**SECURITY CLASSIFICATION OF THIS PAGE(When Data Entered)**

**FOREWORD**

This report was prepared in the Mechanics and Surface Interactions Branch (AFML/MBM), Nonmetallic Materials Division, Air Force Materials Laboratory, Wright-Patterson Air Force Base, Ohio. The work was performed under the support of Project No. 2419 "Nonmetallic Structural Materials," Task No. 241903 "Composite Materials and Mechanics Technology." The time period covered by the effort was 1 March 1978 to 1 December 1978. Stephen W. Tsai (AFML/MBM) was the laboratory project engineer. H. Thomas Hahn continued to contribute to this work after he left AFML in 1 August 1978. ✓

ACCESSION for	
NTIS	Write Section <input checked="" type="checkbox"/>
BDC	Buff Section <input type="checkbox"/>
UNANNOUNCED	<input type="checkbox"/>
JUSTIFICATION	.....
BY	
DISTRIBUTION/AVAILABILITY CODES	
01	SPECIAL
<b>A</b>	

## TABLE OF CONTENTS

SECTION		PAGE
I	STIFFNESS OF UNIDIRECTIONAL COMPOSITES	1
	1. Stress	3
	2. Strain	8
	3. Stress-Strain Relations	11
	4. Symmetry of Compliance and Modulus	19
	5. Stiffness Data for Typical Unidirectional Composites	22
	6. Sample Problems	26
II	TRANSFORMATION OF STRESS AND STRAIN	29
	1. Background	31
	2. Transformation of Stress	35
	3. Numerical Examples of Stress Transformation	44
	4. Transformation of Strain	52
	5. Numerical Examples of Strain Transformation	59
III	OFF-AXIS STIFFNESS OF UNIDIRECTIONAL COMPOSITES	63
	1. Off-Axis Modulus	65
	2. Examples of Off-Axis Modulus	76
	3. Off-Axis Compliance	88
	4. Examples of Off-Axis Compliance	95
	5. Inverse Relationship Between Modulus and Compliance	104
IV	IN-PLANE STIFFNESS OF SYMMETRIC LAMINATES	107
	1. Laminate Code	110
	2. In-Plane Stress-Strain Relation for Laminates	112
	3. Evaluation of In-Plane Modulus	119
	4. Cross-Ply Laminates	126
	5. Angle-Ply Laminates	131
	6. Quasi-Isotropic Laminates	139
	7. Generalized $\text{PI}/4$ Laminates	142

## TABLE OF CONTENTS (Concluded)

SECTION		PAGE
V	<b>FLEXURAL STIFFNESS OF SYMMETRIC SANDWICH LAMINATES</b>	147
	1. Laminate Code	150
	2. Moment-Curvature Relations	151
	3. Evaluation of Flexural Modulus	162
	4. Flexural Behavior of Unidirectional Laminates	168
	5. Flexural Modulus of Cross-Ply Laminates	175
	6. Flexural Modulus of Symmetric Laminates	185
	7. Ply Stress and Ply Strain Analysis	187

## LIST OF TABLES

TABLE		PAGE
1	Stress Components in Contracted Notation	4
2	Unit Vectors for Simple Stress States	5
3	Strain Components in Contracted Notation	10
4	On-Axis Stress-Strain Relation for Unidirectional Composites in Terms of Engineering Constants	16
5	On-Axis Stress-Strain Relation for Unidirectional Composites in Terms of Compliance	17
6	On-Axis Stress-Strain Relation for Unidirectional Composites in Terms of Modulus	18
7	Engineering Constants, Fiber Volume and Specific Gravity of Typical Unidirectional Composites	23
8	Compliance Components of Typical Unidirectional Composites (TPa) <sup>-1</sup>	24
9	Modulus Components of Typical Unidirectional Composites (GPa)	25
10	Stress Transformation Equations in Power Functions	38
11	Stress Transformation in Double Angle Functions - I	40
12	Stress Transformation in Double Angle Functions - II	40
13	Stress Transformation in Invariant Functions	43
14	Strain Transformation Equations in Power Functions	56
15	Strain Transformation in Double Angle Functions - I	56
16	Strain Transformation in Double Angle Functions - II	57
17	Strain Transformation in Invariant Functions	58
18	Off-Axis Stress-Strain Relation for Unidirectional Composites in Terms of Modulus	68
19	Transformation of Modulus from On-Axis Unidirectional Composites in Power Functions	70
20	Transformed Modulus from On-Axis Unidirectional Composites in Multiple-Angle Functions	73
21	Transformed Modulus from On-Axis Unidirectional Composites in Invariant Functions	76
22	Transformed Modulus of T300/5208 Unidirectional Composites (GPa)	77

LIST OF TABLES (Continued)

TABLE		PAGE
23	Linear Combinations of Modulus Transformation of Modulus (GPa)	79
24	Off-Axis Stress-Strain Relation for Unidirectional Composites in Terms of Compliance	89
25	Transformation of Compliance of On-Axis Unidirectional Composites in Power Functions	90
26	Transformed Compliance for On-Axis Unidirectional Composites in Multiple-Angle Functions	91
27	Transformed Compliance of On-Axis Unidirectional Composites in Invariant Functions	93
28	Typical Values of Linear Combinations of Compliance for On-Axis Unidirectional Composites (TPa) <sup>-1</sup>	96
29	Transformed Compliance for T300/5208 Unidirectional Composites (TPa) <sup>-1</sup>	96
30	Off-Axis Stress-Strain Relation for Unidirectional Composites in Terms of Modulus	104
31	Off-Axis Stress-Strain Relation for Unidirectional Composites in Terms of Compliance	104
32	In-Plane Stress-Strain Relation of Symmetric Laminates in Terms of Modulus	116
33	In-Plane Stress-Strain Relation of Symmetric Laminates in Terms of Compliance	117
34	Formulas for In-Plane Modulus of Laminates	121
35	Formulas for Normalized In-Plane Modulus	125
36	Values of Trigonometric Functions for Cross-Ply Laminates	126
37	Formulas for In-Plane Modulus for Cross-Ply Composites	127
38	Formulas for In-Plane Modulus for Angle-Ply Laminates	132
39	In-Plane Modulus of Angle-Ply Laminates of T300/5208 (GPa)	134
40	Values of Trigonometric Functions for In-Plane Modulus of Generalized PI/4 Laminates	142

LIST OF TABLES (Continued)

TABLE		PAGE
41	Formulas for In-Plane Modulus of Generalized PI/4 Laminates	143
42	Moment-Curvature Relation of Symmetric Laminates in Terms of Modulus	160
43	Moment-Curvature Relation of Symmetric Laminates in Terms of Compliance	160
44	Formulas for Flexural Modulus of Symmetric Sandwich Laminates	164
45	Numerical Evaluation of Weighting Factor for the Flexural Modulus of Symmetric Sandwich Laminates	167
46	Formulas for the Flexural Modulus of Unidirectional Composites	169
47	Values of Trigonometric Functions for Cross-Ply Laminates	175
48	Formulas for Flexural Modulus of a Solid Symmetric [0/90] Cross-Ply Laminate	177
49	Formulas for Flexural Modulus of a Symmetric Sandwich Laminate with [0/90] Facings	182

## LIST OF ILLUSTRATIONS

FIGURE		PAGE
1	Schematic Relations Between Local and Average Stresses	4
2	Stress Components in Three-Dimensional Stress-Space	6
3	Longitudinal Uniaxial Stresses in Tension and Compression	6
4	Transverse Uniaxial Stress in Tension and Compression	6
5	Positive and Negative Longitudinal Shears	6
6	Sign Convention for Stress Components	7
7	Normal Strain and Displacement Relations	8
8	The Strain-Displacement Relation for Shear Strain	9
9	Unit Strain Vectors Resulting from Uniaxial Stresses	11
10	Two Orthotropic Planes of Symmetry of Unidirectional Composites	12
11	Uniaxial Longitudinal Tensile Test	13
12	Uniaxial Transverse Tensile Test	14
13	Longitudinal Shear Test	15
14	Material Symmetry Axes of a Unidirectional Composite	31
15	Off-Axis or Generally Orthotropic Configuration of a Unidirectional Composite	31
16	Determination of the Off-Axis Compliance Using Positive Stress Transformation, On-Axis Stress-Strain Relation and Negative Strain Transformation	33
17	Determination of the Off-Axis Modulus Using Positive Strain Transformation, On-Axis Stress-Strain Relations in Modulus and Negative or Inverse Stress Transformation	34
18	Stress Transformation: Changes in Stress Components Due to Coordinate Rotation or Transformation	35
19	Free-Body Diagram for the Balance of Stress Components	37

LIST OF ILLUSTRATIONS (Continued)

FIGURE		PAGE
20	Free-Body Diagram for Balance of Stress Components	38
21	Geometric Relations of Second-Order Stress Invariant +R and Mohr Circle	42
22	Stress Transformation: Changes in Stress Components Due to Coordinate Transformation	44
23	Four Possible States of Stress	46
24	Principal Stress Components	48
25	Inverse Stress Transformation	49
26	Inverse Stress Transformation of That Illustrated in Figure 25	50
27	Positive and Negative Angles of Rotation	51
28	Strain Transformation	52
29	Coordinate Systems Between the Primed and Unprimed Axes	54
30	Strain Transformation	60
31	Determination of the Off-Axis Modulus Using Positive Strain Transformation, On-Axis Stress-Strain Relations in Modulus, and Negative or Inverse Stress Transformation	65
32	The Off-Axis Stress-Strain Relations in Modulus	68
33	A New, Unprimed Coordinate System	69
34	Positive Ply Orientation is Shown	71
35	Transformed, Off-Axis Modulus of T300/5208	78
36	Transformed Modulus as Functions of $U_i$	81
37	Relationships Between Transformed Modulus	85
38	Approximation of Transformed Modulus	86
39	Derivation of Off-Axis Compliance	88
40	Off-Axis Uniaxial Tensile Test	95
41	Transformed, Off-Axis Compliance of T300/5208	97
42	Comparison of Exact and Approximate Transformed Compliance in Terms of the Multiple-Angle Functions for T300/5208	99

LIST OF ILLUSTRATIONS (Continued)

FIGURE		PAGE
43	Contributions of $S_{22}$ and $S_{66}$ to the Transformed Compliance for T300/5208	100
44	Transformed Engineering Constants for T300/5208	102
45	Relation of Off-Axis Compliance and Modulus	106
46	Typical Stacking Sequence of a Symmetric Laminate	111
47	Ply Orientations as Function of $z$	111
48	Definition of Average Stress	113
49	Reference Coordinate System 1-2 for Typical Multi-directional Laminates	114
50	On-Axis Ply Strain and Stress Calculations	118
51	Definitions of Terms in a Symmetric Laminate	122
52	In-Plane Modulus of Cross-Ply Composites	128
53	In-Plane Compliance of Cross-Ply Composites	130
54	In-Plane Modulus of Angle-Ply Laminate of T300/5208 Composite	135
55	In-Plane Compliance of T300/5208 Angle-Ply Laminates	136
56	Comparison Between Elastic Constants of Angle Ply and Unidirectional Composites	138
57	In-Plane Modulus of Generalized $\pi/4$ Laminates of T300/5208 Composite	145
58	Dimensions and Stacking Sequence of Symmetric Sandwich Laminates	150
59	Stress Variations Across Laminates	152
60	The Positive Directions of Components of Moment	153
61	Definition of a Plate or Laminate Before and After Bending	155
62	Sign Convention of Midplane Displacements	156
63	Assumed Linear Strain Distribution Across Laminate Thickness	158
64	Schematic Diagram of a Symmetric Sandwich Laminate	164
65	Transformed Flexural Modulus of Unidirectional T300/5208	170

**LIST OF ILLUSTRATIONS (Concluded)**

<b>FIGURE</b>		<b>PAGE</b>
66	<b>Transformed Flexural Compliance of Unidirectional T300/5208</b>	172
67	<b>Pure Bending of An Off-Axis Beam</b>	174
68	<b>Cross-Ply Laminates with 16 Plies but Different Number of Ply Assemblies</b>	175
69	<b>Flexural Modulus Components as Functions of Ply Assemblies for a T300/5208 Laminate</b>	179
70	<b>Cross-Ply Sandwich Laminates</b>	180
71	<b>Flexural Modulus for a Sandwich Laminate of T300/5208 as Functions of the Number of Ply Assemblies</b>	184
72	<b>Ply Stress and Strain in a Symmetric Laminate</b>	187

SECTION I  
STIFFNESS OF UNIDIRECTIONAL COMPOSITES

SCOPE

The stiffness of unidirectional composites, like any other structural material, can be defined by appropriate stress-strain relations. We will show that the coefficients or material constants of these relations can be packaged in a set of engineering constants, compliance components, or modulus components. The components of any one set are directly expressible in terms of the components of the other sets. Each set, however, possesses unique characteristics that make it suitable for specific usage. We intend to demonstrate that the stiffness of unidirectional composites is governed by the same stress-strain relation that is valid for ordinary materials. The number of independent constants are four for composites and two for ordinary materials. We will show the stiffness data for several typical unidirectional composites. We can then compute stress from strain, or strain from stress. We intend to show that composites are conceptually and operationally as simple as ordinary materials. Two key relations are:

	$\epsilon_1$	$\epsilon_2$	$\epsilon_6$
$\sigma_1$	$Q_{11}$	$Q_{12}$	0
$\sigma_2$	$Q_{21}$	$Q_{22}$	0
$\sigma_6$	0	0	$Q_{66}$

	$\sigma_1$	$\sigma_2$	$\sigma_6$
$\epsilon_1$	$S_{11}$	$S_{12}$	0
$\epsilon_2$	$S_{21}$	$S_{22}$	0
$\epsilon_6$	0	0	$S_{66}$

## NOMENCLATURE

- E** = Young's modulus for isotropic materials
- E<sub>L</sub>** = Longitudinal modulus
- E<sub>T</sub>** = Transverse modulus
- G** = Shear modulus for isotropic materials
- G<sub>LT</sub>** = Longitudinal-transverse shear modulus
- m** = Dimensionless multiplying constant =  $\left[ 1 - \nu_{LT} \nu_{TL} \right]^{-1}$
- Q<sub>ij</sub>** = Modulus components; i, j = 1, 2, 6
- S<sub>ij</sub>** = Compliance components; i, j = 1, 2, 6
- u** = Displacement along x-axis
- v** = Displacement along y-axis
- w** = Stored elastic energy
- $\sigma_i$**  = Stress components; i, j = 1, 2, 6
- $\epsilon_i$**  = Strain components; i, j = 1, 2, 6
- $\nu$**  = Poisson's ratio for isotropic materials
- $\nu_{LT}$**  = Major Poisson's ratio
- $\nu_{TL}$**  = Minor Poisson's ratio
- Sub 1** = Normal component along 1-axis
- Sub 2** = Normal component along 2-axis
- Sub 6** = Shear component in 1-2 plane

## 1. STRESS

Stress is a measure of internal forces within a body. This together with strain are the key variables for the determination of stiffness and strength of a material. The mechanisms of deformation and failure are also interpreted in terms of the state of stress and strain. They are the fundamental variables for the mechanical behavior of materials similar to temperature and heat flux for heat conduction, and pressure, volume, and temperature for gas.

There is no direct measurement for stress. Instead, stress is inferred or derived from the following:

- Applied forces using stress analysis.
- Measured displacements also using stress analysis.
- Measured strains using stress-strain relations.

When we talk about stress we usually mean the average stress over some physical dimension. This is similar to population measured over a city, county, or state. In our study of composites we deal with three levels of average stress:

- Micromechanical stress  $\bar{\sigma}$  is that calculation based on distinct phases of fiber, matrix, and in some cases the interface and voids.
- Ply stress  $\bar{\sigma}$  is that calculation based on assumed homogeneity with each ply or ply assembly in which the fiber and matrix are smeared.
- Laminate stress or stress resultant  $N/h$  is the average of ply stresses across the thickness of a laminate.

In Fig. 1 we show two levels of this idealization of average stresses. On the micromechanical level in (a), the fiber and matrix stresses vary from point to point within each constituent phase. The average of these stresses

is the ply stress  $\bar{\sigma}$ . In a laminate or on the macromechanical level, each ply or ply assembly has its own ply stress. The average of several ply stresses is the laminate stress or stress resultant  $N/h$ .

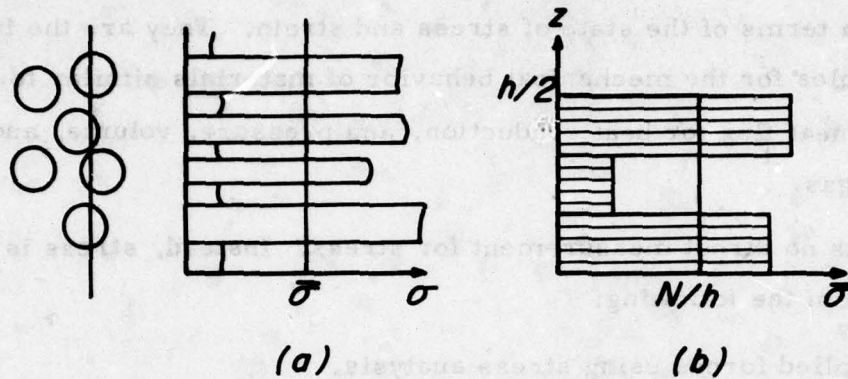

Fig. 1. Schematic relations between local and average stresses:

- (a) Micromechanical level where stresses in fiber and matrix are recognized.
- (b) Macromechanical level where stresses in plies and ply assemblies are recognized.

We will use contracted notation in this book. Single subscripts for stress and strain, and double subscripts for compliance and modulus will be followed. The conversion from the conventional or tensorial notation to the contracted notation is shown in Table 1.

Table 1. STRESS COMPONENTS IN CONTRACTED NOTATION

CONVENTIONAL OR TENSORIAL NOTATION				CONTRACTED NOTATION
$\sigma_x$	$\sigma_{xx}$	$\sigma_1$	$\sigma_{11}$	$\sigma_1$
$\sigma_y$	$\sigma_{yy}$	$\sigma_2$	$\sigma_{22}$	$\sigma_2$
$\sigma_{xy}$	$\sigma_{xy}$	$\sigma_{12}$	$\sigma_{12}$	$\sigma_6$

The use of subscript 6 for the shear stress component is derived from the 6 components in 3-dimensional stress. Although subscript 3 has occasionally been used for this shear component, it is a source of confusion since 3 can be used for the 3rd normal stress component in 3-dimensional problems. Subscript 6 is used to avoid this confusion.

The state of stress in a ply or ply assembly is predominantly plane stress. The nonzero components of plane stress are those listed in Table 1. The remaining three components are of secondary and local nature, and will not be treated in this book. It is convenient to represent the state of plane stress in a 3-dimensional stress-space where the three orthogonal axes correspond to the three stress components. The stress-space is shown in Fig. 2. Here each applied stress, represented by three stress components, can be readily portrayed as a vector in a 3-dimensional space. The unit vector which signifies the direction of the applied stress are represented by the conventional notation of

$$(\underline{i}, \underline{j}, \underline{k})$$

where the components of the unit vectors are directional cosines. All three unit vectors are shown in Fig. 2. Typical unit vectors for simple states of stress will be shown in the following table:

Table 2. UNIT VECTORS FOR SIMPLE STRESS STATES

Type of Stress	Unit Vector	Figure No.
Longitudinal tension	(1, 0, 0)	3
Longitudinal compression	(-1, 0, 0)	3
Transverse tension	(0, 1, 0)	4
Transverse compression	(0, -1, 0)	4
Positive longitudinal shear	(0, 0, 1)	5
Negative longitudinal shear	(0, 0, -1)	5

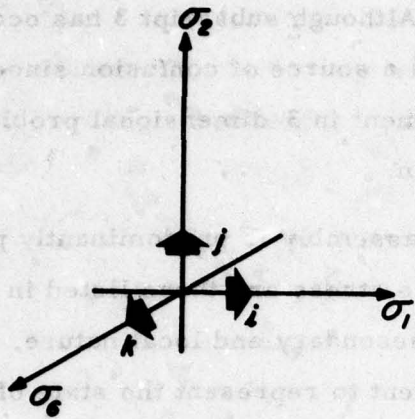

**Fig. 2. Stress components in 3-dimensional stress-space. Unit stress vectors are also shown as arrows.**

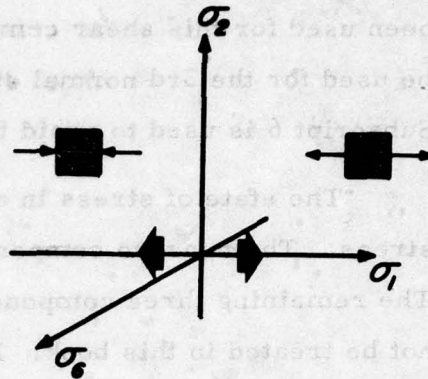

**Fig. 3. Longitudinal uniaxial stresses in tension and compression. The respective unit vectors are  $(\pm 1, 0, 0)$ .**

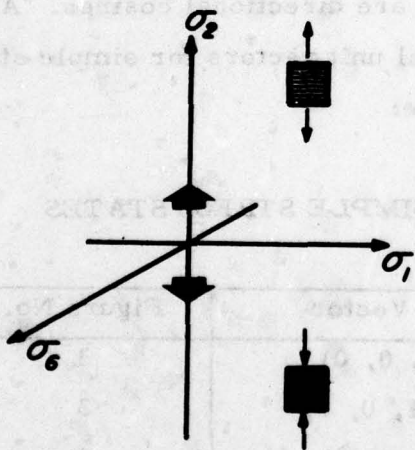

**Fig. 4. Transverse uniaxial stress in tension and compression. The respective unit vectors are  $(0, \pm 1, 0)$ .**

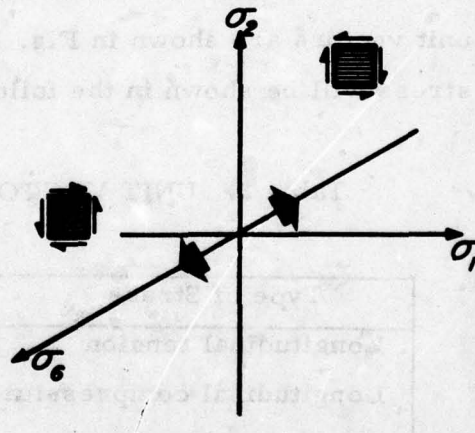

**Fig. 5. Positive and negative longitudinal shears. The respective unit vectors are  $(0, 0, \pm 1)$ .**

The sign convention must be observed faithfully when we deal with composites. The difference between tensile and compressive strengths may be several hundred percent. Moreover, there can be an even greater difference between positive and negative shear strengths in composites. A 50/50 percent guess is not good enough. For ordinary materials signs are often immaterial, but here this attitude can be fatal. We must be precise and accurate about signs. This is a necessary discipline when we work in composites.

In Fig. 6 the sign convention is shown in detail. All components in (a) are positive; in (b), negative. For the normal components, signs are no problem. Shear, however, is more difficult. The rule is that a shear is positive if the shear is acting on a positive face and directed toward a positive axis; or the shear is positive if it is acting on a negative face and directed toward a negative axis. Thus, two positives or two negatives would make a positive shear. If we have a mixture of positive and negative the shear is negative.

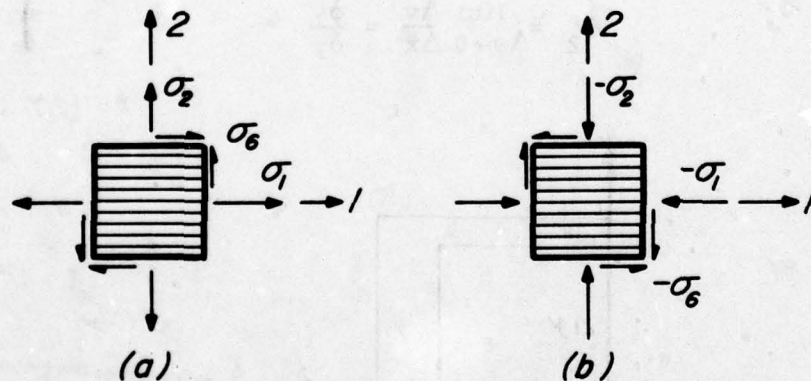

Fig. 6. Sign convention for stress components:

(a) All components shown are positive.

(b) All components shown are negative.

## 2. STRAIN

Strain is a purely geometric quantity; no material property or conservation principles are involved. First we will show the geometric relations between strain components and displacements. Then we can establish the stress-strain relation. The constants in this relation govern the stiffness of composites as well as ordinary materials.

Relative displacements in a plane will induce 2-dimensional strain. If the displacements do not vary from point to point within a material, there will only be rigid body motion and no strain. Thus, strain is simply the spatial variation of the displacements.

Let  $\Delta u$  = Relative displacement along x-axis

$\Delta v$  = Relative displacement along y-axis

From Fig. 7 we can define:

$$\left. \begin{aligned} \epsilon_1 &= \lim_{\Delta x \rightarrow 0} \frac{\Delta u}{\Delta x} = \frac{\partial u}{\partial x} \\ \epsilon_2 &= \lim_{\Delta y \rightarrow 0} \frac{\Delta v}{\Delta y} = \frac{\partial v}{\partial y} \end{aligned} \right\} (1)$$

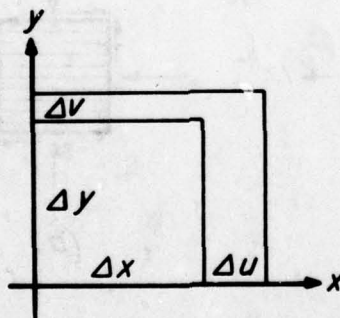

Fig. 7. Normal strain and displacement relations

The partial differentiation is used because the displacements are functions of both x and y coordinates. Strain, like stress, is a local property. In general it varies from point to point in a material. Only in special

cases is the state of strain or stress uniform; we call this homogeneous strain or stress. This special case is pertinent to testing for property determination where we deliberately try to create a simple, homogeneous strain or stress.

Note that the normal strain components are associated with changes in the lengths of an infinitesimal element. The rectangular element before deformation remain rectangular although the lengths of sides may change. There is no distortion produced by the normal strain components. Distortion is measured by the change of angles. The original rectangular element would be distorted into a parallelogram. Geometrically this is equivalent to stretching one diagonal and compressing the other. This combined action will produce distortion which is measured by shear strain. Fig. 8 shows the combined action produced by the same two incremental displacements that produced the normal strain components in Eq. 1. The desired shear strain is:

$$\epsilon_6 = a + b \quad (2)$$

$$\text{where } a = \tan a \approx \frac{\partial v}{\partial x} \quad (3)$$

$$b = \tan b \approx \frac{\partial u}{\partial y}$$

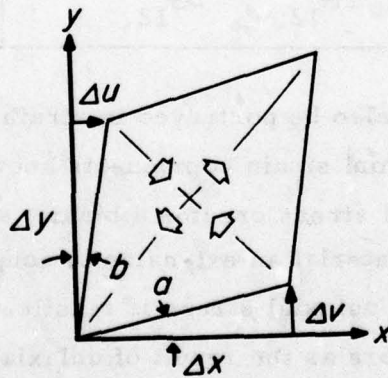

Fig. 8. The strain-displacement relation for shear strain. The arrows show the direction of stretching and compressing the diagonals.

The resulting strain displacement relation is

$$\epsilon_6 = \frac{\delta v}{\delta x} + \frac{\delta u}{\delta y} \quad (4)$$

This is the engineering shear strain which is twice the tensorial strain. Engineering shear strain is used because it measures the total change in angle, or the total angle of twist in the case of a rod under torsion. This factor of 2 is often a source of confusion. When in doubt, the strain-displacement equation, in Eq. 4, is the best place for reference.

As with stress, contracted notation will be used for strain components. The conversion table between the components of the conventional or tensorial strain and the contracted strain will be listed in Table 3.

Table 3. STRAIN COMPONENTS IN CONTRACTED NOTATION

CONVENTIONAL OR TENSORIAL NOTATION				CONTRACTED NOTATION
$\epsilon_x$	$\epsilon_{xx}$	$\epsilon_1$	$\epsilon_{11}$	$\epsilon_1$
$\epsilon_y$	$\epsilon_{yy}$	$\epsilon_2$	$\epsilon_{22}$	$\epsilon_2$
$2\epsilon_{xy}$	$2\epsilon_{xy}$	$2\epsilon_{12}$	$2\epsilon_{12}$	$\epsilon_6$

Strain vectors can also be portrayed in strain-space. Because of the coupling between the normal strain components known as the Poisson's effect, the response to a uniaxial stress creates a biaxial strain state. For example, for ordinary material an extension is coupled with a lateral contraction if the applied uniaxial stress is tensile. In Fig. 9 we will show the unit strain vectors as the result of uniaxial longitudinal and transverse tensile stresses in (a) and (b), respectively: If the applied stress is compressive, the direction of all the stress and strain unit vectors shall be reversed.

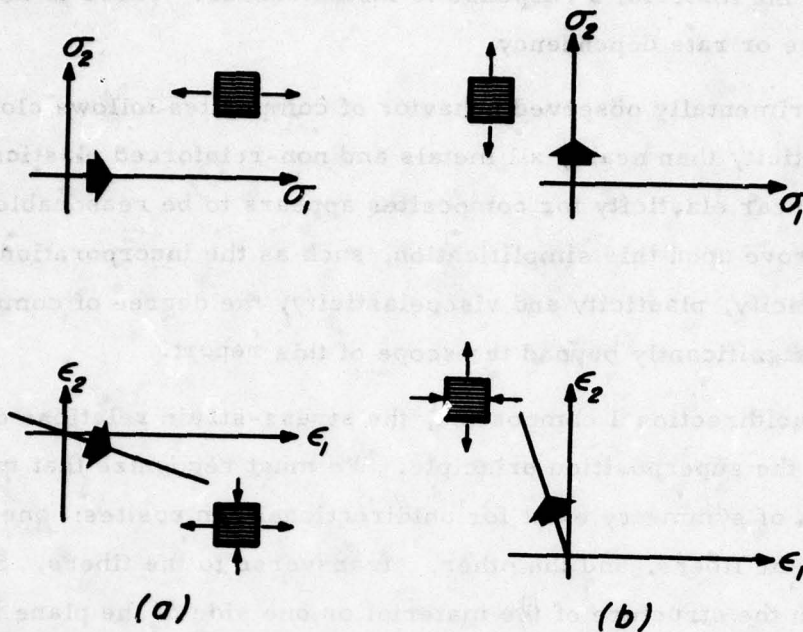

Fig. 9. Unit strain vectors resulting from uniaxial stresses

- (a) Biaxial strain  $(1, -\nu, 0)$  resulting from uniaxial stress  $(1, 0, 0)$ .
- (b) Biaxial strain  $(-\nu, 1, 0)$  resulting from uniaxial stress  $(0, 1, 0)$ .

### 3. STRESS-STRAIN RELATIONS

We will limit the composites of this report to the linearly elastic materials. The response of materials under stress or strain follows a straight line up to failure in stress or strain space. Assumed linearity moreover permits us to use superposition which is a very powerful tool. For example, the net result of combining two states of stress is precisely the sum of the two states--no more and no less. The sequence of the stress application is immaterial. We can assemble or dissect components of stress and strain in whatever pattern we choose without affecting the result. Combined stresses are the sum of simple stresses.

Secondly, elasticity means full reversibility. We can load and unload and reload a material without incurring any hysteresis. Elasticity also

means that the material's response is instantaneous. There is no time lag, no time or rate dependency.

Experimentally observed behavior of composites follows closer to linear elasticity than nearly all metals and non-reinforced plastics. The assumed linear elasticity for composites appears to be reasonable. If we are to improve upon this simplification, such as the incorporation of non-linear elasticity, plasticity and viscoelasticity, the degree of complexity is increased significantly beyond the scope of this report.

For unidirectional composites, the stress-strain relations can be derived by the superposition principle. We must recognize that two orthogonal planes of symmetry exist for unidirectional composites: one plane is parallel to the fibers, and the other, transverse to the fibers. Symmetry exists when the structure of the material on one side of the plane is the mirror image of the structure on the other side. The two orthogonal planes are shown in Fig. 10, where the 1-axis is along the longitudinal direction of the fiber while the 2-axis is in the transverse direction. When the reference axes 1-2 coincide with the material symmetry axes, we call this the on-axis orientation. The stress-strain relation in this section is limited to this special case, which is shown in Fig. 10. The off-axis orientation will be discussed in later sections.

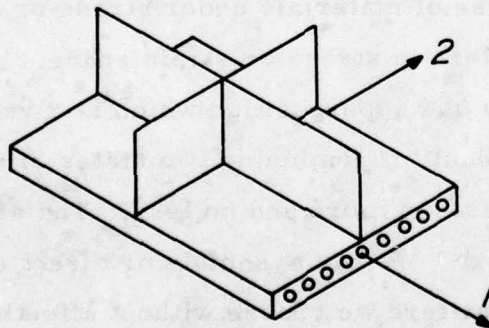

Fig. 10. Two orthotropic planes of symmetry of unidirectional composites. Axes 1-2 coincide with the longitudinal and transverse directions. This material symmetry is called orthotropic and on-axis.

The on-axis stress-strain relation can be derived by superpositioning the results of the following simple tests:

a. Uniaxial Longitudinal Test

The applied uniaxial stress and the resulting biaxial strain were shown in Fig. 9a. The stress-strain curves for this test are shown in Fig. 11, from which we can establish the following stress-strain relations:

$$\left. \begin{aligned} \epsilon_1 &= \frac{1}{E_L} \sigma_1 \\ \epsilon_2 &= -\frac{\nu_{LT}}{E_L} \sigma_1 \end{aligned} \right\} \quad (5)$$

where  $E_L$  = Longitudinal Modulus

$$\nu_{LT} = \text{Major Poisson's Ratio} = -\frac{\epsilon_2}{\epsilon_1}$$

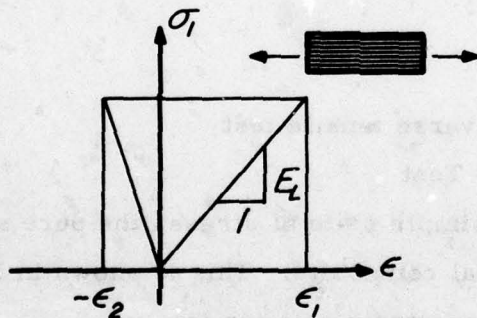

Fig. 11. Uniaxial longitudinal tensile test

b. Uniaxial Transverse Test

The applied uniaxial stress and the resulting biaxial strain were shown in Fig. 9b. The stress-strain curves for this test were shown in Fig. 12, from which the following stress-strain relations can be established:

$$\epsilon_2 = \frac{1}{E_T} \sigma_2$$

(6)

$$\epsilon_1 = -\frac{\nu_{TL}}{E_T} \sigma_2$$

where  $E_T$  = Transverse Modulus

$$\nu_{TL} = \text{Minor Poisson's Ratio} = -\frac{\epsilon_1}{\epsilon_2}$$

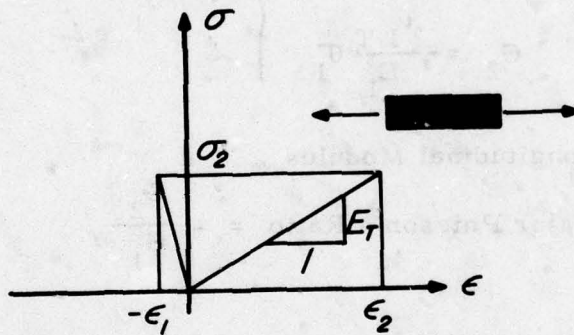

Fig. 12. Uniaxial transverse tensile test

c. Longitudinal Shear Test

We apply another simple state of stress, the pure shear, to our unidirectional composite. This is shown in Fig. 13.

The resulting stress-strain relation is:

$$\epsilon_6 = \frac{1}{G_{LT}} \sigma_6 \quad (7)$$

where  $G_{LT}$  = Longitudinal Shear Modulus

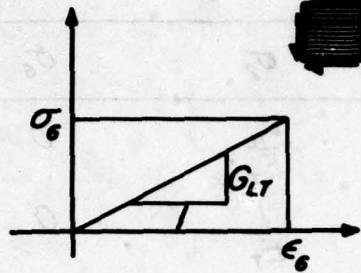

Fig. 13. Longitudinal shear test

By applying the principle of superposition, we can sum up the contribution of each stress component in Eq. 5, 6, and 7 to the resulting strain components. The final stress-strain relation for our unidirectional composite is:

$$\epsilon_1 = \frac{1}{E_L} \sigma_1 - \frac{\nu_{TL}}{E_T} \sigma_2$$

$$\epsilon_2 = -\frac{\nu_{LT}}{E_L} \sigma_1 + \frac{1}{E_T} \sigma_2 \quad (8)$$

$$\epsilon_6 = \frac{1}{G_{LT}} \sigma_6$$

This is the on-axis stress-strain relation of a unidirectional composite; i.e., the material is in its orthotropic symmetry orientation.

These simultaneous equations can be repackaged in a matrix multiplication table, wherein each row in the table is equal to the sum of products from each column and its column heading. This rule should be self-evident if we compare the first of Eq. 8 with the first row of Table 4. This and all subsequent tables will be drawn in italics when matrix multiplication is in force.

**Table 4. ON-AXIS STRESS-STRAIN RELATION FOR UNIDIRECTIONAL COMPOSITES IN TERMS OF ENGINEERING CONSTANTS**

	$\sigma_1$	$\sigma_2$	$\sigma_6$
$\epsilon_1$	$\frac{1}{E_L}$	$-\frac{\nu_{TL}}{E_T}$	0
$\epsilon_2$	$-\frac{\nu_{LT}}{E_L}$	$\frac{1}{E_T}$	0
$\epsilon_6$	0	0	$\frac{1}{G_{LT}}$

All the material constants of the stress-strain relation shown in this table are called engineering constants. They are the familiar constants used for ordinary materials with subscripts added to denote the directionality of properties. Many design formulas for structural elements are written in terms of engineering constants. Thus the use of engineering constants will often facilitate the use of composites for structural applications. This concession to the state-of-the-art design methodology, however, can lead to an unnecessarily complicated design procedure. In fact, engineering constants for composites are clumsy, and should be replaced by the components of compliance and modulus. A change of notation from engineering constants in Table 4 to components of compliance in Table 5 can be done by direct substitution.

Table 5. ON-AXIS STRESS-STRAIN RELATION FOR UNIDIRECTIONAL COMPOSITES IN TERMS OF COMPLIANCE

	$\sigma_1$	$\sigma_2$	$\sigma_6$
$\epsilon_1$	$S_{11}$	$S_{12}$	0
$\epsilon_2$	$S_{21}$	$S_{22}$	0
$\epsilon_6$	0	0	$S_{66}$

The relations between these two sets of elastic constants are:

$$\begin{aligned}
 S_{11} &= \frac{1}{E_L} & S_{22} &= \frac{1}{E_T} \\
 S_{12} &= -\frac{\nu_{TL}}{E_T} & S_{21} &= -\frac{\nu_{LT}}{E_L} \\
 S_{66} &= \frac{1}{G_{LT}}
 \end{aligned} \tag{9}$$

or conversely,

$$\begin{aligned}
 E_L &= \frac{1}{S_{11}} & E_T &= \frac{1}{S_{22}} \\
 \nu_{LT} &= -\frac{S_{21}}{S_{11}} & \nu_{TL} &= -\frac{S_{12}}{S_{22}}
 \end{aligned} \tag{10}$$

$$G_{LT} = \frac{1}{S_{66}}$$

From Eq. 8 we can solve for stress in terms of strain for which we have the following equations:

$$\begin{aligned}\sigma_1 &= m E_L [\epsilon_1 + \nu_{TL} \epsilon_2] \\ \sigma_2 &= m E_T [\nu_{LT} \epsilon_1 + \epsilon_2] \\ \sigma_6 &= G_{LT} \epsilon_6\end{aligned}\tag{11}$$

where  $m = [1 - \nu_{LT} \nu_{TL}]^{-1}$

In order to eliminate the clumsiness of engineering constants in this stress-strain relation, we will introduce components of modulus in Table 6.

Table 6. ON-AXIS STRESS-STRAIN RELATION FOR UNIDIRECTIONAL COMPOSITES IN TERMS OF MODULUS

	$\epsilon_1$	$\epsilon_2$	$\epsilon_6$
$\sigma_1$	$Q_{11}$	$Q_{12}$	0
$\sigma_2$	$Q_{21}$	$Q_{22}$	0
$\sigma_6$	0	0	$Q_{66}$

The following relations exist between engineering constants and the components of modulus:

$$\begin{aligned}Q_{11} &= m E_L & Q_{22} &= m E_T \\ Q_{12} &= m \nu_{TL} E_L & Q_{21} &= m \nu_{LT} E_T \\ Q_{66} &= G_{LT}\end{aligned}\tag{12}$$

or conversely

$$\begin{aligned}
 E_L &= \frac{Q_{11}}{m} & E_T &= \frac{Q_{22}}{m} \\
 \nu_{LT} &= \frac{Q_{21}}{Q_{22}} & \nu_{TL} &= \frac{Q_{12}}{Q_{11}} \\
 G_{LT} &= Q_{66}
 \end{aligned} \tag{13}$$

$$\text{where } m = \left[ 1 - \frac{Q_{12}}{Q_{11}} \frac{Q_{21}}{Q_{22}} \right]^{-1}$$

We have seen three sets of material constants, any of which can completely describe the stiffness of on-axis unidirectional composites. The characteristics of each set is summarized in the following:

- Modulus is used to calculate the stress from strain. This is the basic set needed for the stiffness of multidirectional laminates.
- Compliance is used to calculate the strain from stress. This is the set needed for the calculation of engineering constants.
- Engineering constants are the carryover from the ordinary materials. Old designers feel more comfortable working with the engineering constants.

As stated earlier, from one set of constants we can readily find the other sets. They are all equivalent. There is a direct relationship between the modulus and compliance. One is the inverse of the other. We will discuss the process of inversion later.

#### 4. SYMMETRY OF COMPLIANCE AND MODULUS

We wish to show that the coupling components of compliance and those of modulus are equal, or in the terminology of matrix algebra, that the compliance and modulus matrices are symmetric. Since the only coupling that we have seen thus far is the Poisson coupling, the symmetry condition

states that the coupling components are equal, as follows:

$$S_{12} = S_{21}, \quad Q_{12} = Q_{21} \quad (14)$$

We can demonstrate the validity of these equalities from the stored elastic energy in a body subjected to stress and strain. Let the stored energy at a point in the orthotropic body be

$$W = \frac{1}{2} \left[ \sigma_1 \epsilon_1 + \sigma_2 \epsilon_2 + \sigma_6 \epsilon_6 \right] \quad (15)$$

From this definition we see

$$\frac{\partial W}{\partial \sigma_1} = \epsilon_1, \quad \frac{\partial W}{\partial \sigma_2} = \epsilon_2, \quad \frac{\partial W}{\partial \sigma_6} = \epsilon_6 \quad (16)$$

Substituting the stress-strain relation in terms of compliance from Table 5 into Eq. 15,

$$W = \frac{1}{2} \left[ S_{11} \sigma_1^2 + \frac{1}{2} (S_{12} + S_{21}) \sigma_1 \sigma_2 + S_{22} \sigma_2^2 + S_{66} \sigma_6^2 \right] \quad (17)$$

We will obtain the stress-strain relation by differentiation of this energy term in accordance with Eq. 16,

$$\epsilon_1 = S_{11} \sigma_1 + \frac{1}{2} [S_{12} + S_{21}] \sigma_2 \quad (18)$$

$$\epsilon_2 = \frac{1}{2} [S_{12} + S_{21}] \sigma_1 + S_{22} \sigma_2$$

Matching the like constants between this set and those in Table 5, the only condition that satisfies both sets is

$$S_{12} = S_{21} \quad (19)$$

By substituting the modulus relations in Table 6 into Eq. 15 we can also show that

$$Q_{12} = Q_{21} \quad (20)$$

The last two equations state the symmetry conditions of the Poisson coupling. A similar symmetry condition can be applied to engineering constants. From Eq. 9, for example, we have

$$\nu_{LT} E_T = \nu_{TL} E_L \quad (21)$$

With these symmetry conditions, the number of independent constants for the on-axis orthotropic unidirectional composite are reduced by one, from five to four in Tables 4 to 6. If additional symmetry conditions exist, the number of constants can be further reduced. Specifically, two such cases exist:

- Square Symmetric Materials

If the longitudinal and transverse properties are equal; i. e.,

$$Q_{11} = Q_{22}, S_{11} = S_{22}, \text{ and } E_L = E_T \quad (22)$$

we have a square symmetric material. But because of the additional relation in Eq. 22, the number of independent constants are three, one less than the orthotropic material. A cross-ply laminate is a square symmetric material in the plane of the laminate.

- Isotropic Materials

We know that isotropic materials have only two independent constants because there is another relation among the three remaining constants; i. e.,

$$\begin{aligned} 2Q_{66} &= Q_{11} - Q_{12} \\ S_{66} &= 2(S_{11} - S_{12}) \\ G &= \frac{E}{2(1+\nu)} \end{aligned} \quad (23)$$

This relation is derived from the equivalence between the state of pure shear and that of equal tension-compression. This equivalence is only valid for isotropic materials. The derivations of these relationships will be discussed later.

In summary, the stress-strain relations which govern the stiffness of all materials have the identical form for unidirectional composites as for ordinary materials. No additional terms or more complex relationships exist. The only difference is the number of independent constants; four for composites versus two for ordinary materials. But there are no conceptual and operational barriers that would make composites intrinsically difficult to work with. In fact, once we understand composites, we automatically will understand ordinary materials. Ordinary materials can be treated as special cases of composites.

## 5. STIFFNESS DATA FOR TYPICAL UNIDIRECTIONAL COMPOSITES

a. Measured engineering constants for a number of unidirectional composites are listed in Table 7. The fiber volume fraction and specific gravity are also included.

**Table 7. ENGINEERING CONSTANTS, FIBER VOLUME AND SPECIFIC GRAVITY OF TYPICAL UNIDIRECTIONAL COMPOSITES**

Type	Mat'l	$E_L$	$E_T$	$\nu_{LT}$	$G_{LT}$	$v_f$ %	Sp. Grav.
		GPa	GPa		GPa		
T300/5208	Gr/Ep	181	10.3	0.28	7.17	0.70	1.6
B(4)/5505	B/EP	204	18.5	0.23	5.59	0.5	2.0
AS/3501	Gr/Ep	138	8.96	0.30	7.1	0.66	1.6
Scotchply /1002	Gl/Ep	38.6	8.27	0.26	4.14	0.45	1.8
Kevlar 49 /Epoxy	Aramid /Ep	76	5.5	0.34	2.3	0.60	1.46

b. The compliance components for the same composites in Table 7 are listed in Table 8. These components are computed from Table 7 using the formulas in Eq. 9.

Table 8. COMPLIANCE COMPONENTS OF TYPICAL UNIDIRECTIONAL COMPOSITES (TPa)<sup>-1</sup>

Type	S <sub>11</sub>	S <sub>22</sub>	S <sub>12</sub>	S <sub>66</sub>
T300/5208	5.525	97.09	-1.547	139.5
B(4)5505	4.902	54.05	-1.128	172.7
AS/3501	7.246	111.6	-2.174	140.8
Scotchply /1002	25.91	120.9	-6.744	241.5
Kevlar 49 /Epoxy	13.16	181.8	-4.474	434.8

c. The modulus components for the same composites are listed in Table 9. These components are calculated using the formulas in Eq. 12.

Table 9. MODULUS COMPONENTS OF TYPICAL UNIDIRECTIONAL COMPOSITES (GPa)

Type	Mat'l	m	$Q_{11}$	$Q_{22}$	$Q_{12}$	$Q_{66}$
T300/5208	Gr/Ep	1.0045	181.8	10.34	2.897	7.17
B(4)/5505	B/EP	1.0048	205.0	18.58	4.275	5.79
AS/3501	Gr/Ep	1.0059	138.8	9.013	2.704	7.1
Scotchply /1002	Gl/Ep	1.0147	39.16	8.392	2.182	4.14
Kevlar 49 /Epoxy	Aramid /Ep	1.0084	76.64	5.546	1.886	2.3

## 6. SAMPLE PROBLEMS

### a. Find Strain from Stress

Given stress vector:  $(400, 60, 15)$  MPa (24)

For compliance of T300/5208 from Table 8:

$$\begin{aligned} S_{11} &= 5.525 \quad (\text{TPa})^{-1} \\ S_{22} &= 97.09 \quad " \\ S_{12} &= 1.547 \quad " \\ S_{66} &= 139.5 \quad " \end{aligned} \quad (25)$$

Using stress-strain relation in terms of compliance, such as that in Table 5:

$$\begin{aligned} \epsilon_1 &= (5.525 \times 400 - 1.547 \times 60) \times 10^{-6} \\ &= 2.117 \times 10^{-3} \\ \epsilon_2 &= 5.206 \times 10^{-3} \\ \epsilon_6 &= 139.5 \times 15 \times 10^{-6} = 2.092 \times 10^{-3} \end{aligned} \quad (26)$$

If a different material is used, we only need to replace the compliance components in Eq. 25 with different data. If the new material is Scotchply 1002, we can get the compliance from Table 8.

$$\begin{aligned} S_{11} &= 25.91 \quad (\text{TPa})^{-1} \\ S_{22} &= 120.9 \quad " \\ S_{12} &= -6.744 \quad " \\ S_{66} &= 241.5 \quad " \end{aligned} \quad (27)$$

With the same applied stress as Eq. 24, the resulting strain is:

$$\begin{aligned} \epsilon_1 &= (25.91 \times 400 - 6.744 \times 60) \times 10^{-6} = 9.959 \times 10^{-3} \\ \epsilon_2 &= (-6.744 \times 400 + 120.9 \times 60) \times 10^{-6} = 4.556 \times 10^{-3} \\ \epsilon_6 &= 241.5 \times 15 \times 10^{-6} = 3.623 \times 10^{-3} \end{aligned} \quad (28)$$

Since the glass composite is less stiff than the graphite composite, the strain produced by the same applied stress is expected to be larger in the glass composite. If we compare the strain components by components between Eq. 26 and 28, the strain in the glass composite is larger in two components, and smaller in one. The moral of the story is that biaxial stress and strain states are complex. Disciplined, analytic approach is straightfoward and is definitely preferred over guesswork.

b. Find Stress from Strain

This process is the inverse of the previous process. If we are given the strain in Eq. 26 and apply it to a T300/5208 composite, the resulting stress must be calculated by using

- Stress-strain relation in terms of modulus, such as that in Table 6, and
- Modulus components in Table 9,

$$\begin{array}{rcl}
 Q_{11} & = & 181.8 \quad \text{GPa} \\
 Q_{22} & = & 10.34 \quad \text{"} \\
 Q_{12} & = & 2.897 \quad \text{"} \\
 Q_{66} & = & 7.17 \quad \text{"}
 \end{array} \quad \left. \vphantom{\begin{array}{rcl} Q_{11} \\ Q_{22} \\ Q_{12} \\ Q_{66} \end{array}} \right\} (29)$$

The resulting stress is:

$$\begin{array}{rcl}
 \sigma_1 & = & 181.8 \times 2.117 + 2.897 \times 5.206 = 400 \text{ MPa} \\
 \sigma_2 & = & 2.897 \times 2.117 + 10.34 \times 5.206 = 60 \text{ MPa} \\
 \sigma_6 & = & 7.17 \times 2.092 = 15 \text{ MPa}
 \end{array} \quad \left. \vphantom{\begin{array}{rcl} \sigma_1 \\ \sigma_2 \\ \sigma_6 \end{array}} \right\} (30)$$

Note that the original stress of Eq. 24 has been recovered. If our composite is Scotchply 1002, we should use the modulus components listed in Table 9 for this material:

$$\begin{array}{rcl}
 Q_{11} & = & 39.16 \quad \text{GPa} \\
 Q_{22} & = & 8,392 \quad \text{"} \\
 Q_{12} & = & 2.182 \quad \text{"} \\
 Q_{66} & = & 4.14 \quad \text{"}
 \end{array} \quad \left. \vphantom{\begin{array}{rcl} Q_{11} \\ Q_{22} \\ Q_{12} \\ Q_{66} \end{array}} \right\} (31)$$

The resulting stress from the applied strain in Eq. 28 is:

$$\sigma_1 = 39.16 \times 9.959 + 2.182 \times 4.556 = 400 \text{ MPa}$$

$$\sigma_2 = 2.182 \times 9.959 + 8.392 \times 4.556 = 60 \text{ MPa}$$

$$\sigma_6 = 4.14 \times 3.623 = 15 \text{ MPa}$$

(32)

Note again that the original stress of Eq. 24 has been recovered.

SECTION II  
TRANSFORMATION OF STRESS AND STRAIN

SCOPE

The change of stiffness of unidirectional composites as a function of ply orientation is a unique feature of composites. These orientational variations of stress and strain are the fundamental underlying issues which must be understood. We will derive the relations that govern these variations; namely, the transformation equations. We will show three formulations for the transformation; viz., the conventional power functions, the double angle functions, and the invariant functions. Each formulation has its unique characteristic and is useful for special purposes. All three formulations are equivalent and will yield the same answer. Two key relations for stress and strain transformations in double angle functions are:

	$1$	$\cos 2\theta$	$\sin 2\theta$
$\epsilon_1$	$p'$	$q'$	$r'$
$\epsilon_2$	$p'$	$-q'$	$-r'$
$\epsilon_6$		$2r'$	$-2q'$

	$1$	$\cos 2\theta$	$\sin 2\theta$
$\sigma_1$	$p'$	$q'$	$r'$
$\sigma_2$	$p'$	$-q'$	$-r'$
$\sigma_6$		$r'$	$-q'$

## PRINCIPAL NOMENCLATURE

- I** = first order invariant of stress or strain, depending on the subscript.
- m** =  $\cos \theta$
- n** =  $\sin \theta$
- p** = average of normal stress or strain components; equal to first invariant I.
- q** = one half difference between normal stress or strain components.
- r** = another symbol for shear stress or one half shear strain; this notation is used in conjunction with p and q above.
- R** = a second order invariant of stress or strain; it is the radius of the Mohr circle.
- x, y** = coordinate axes
- x', y'** = new or transformed coordinate axes
- u, v** = displacements along x and y axes.
- u', v'** = displacements along x' and y' axes.
- $\sigma_i$  = stress components in material symmetry axes,  $i = 1, 2, 6$ .
- $\sigma'_i$  = stress components in 1'-2' coordinate system,  $i = 1, 2, 6$ .
- $\sigma_{I, II}$  = principal stress components.
- $\epsilon_i$  = strain components in material symmetry axes,  $i = 1, 2, 6$ .
- $\epsilon'_i$  = strain components in 1'-2' coordinate system,  $i = 1, 2, 6$ .
- $\theta$  = angle of ply orientation; counterclockwise rotation is positive.
- $\theta_o$  = phase angle for stress or strain transformation in the invariant formulation; it is the orientation of the principal axes.
- T<sup>+</sup>, T<sup>-</sup>** = positive and negative or inverse transformation of stress or strain, depending on the subscript. The sign corresponds to that of the ply orientation.

## 1. BACKGROUND

Up to this point, we have only dealt with the stiffness of unidirectional composites in their material symmetry axes, as shown in Fig. 14. In this reference coordinate system, we call this type of symmetry orthotropic; see Fig. 10 for graphic illustration. General orthotropic configuration occurs when the ply orientation is different from 0 or 90. This is shown in Fig. 15. We also call the latter configuration the off-axis as distinguished from the on-axis in Fig. 14.

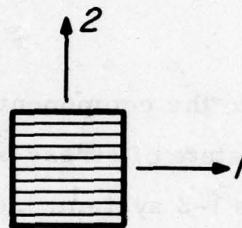

Fig. 14. Material symmetry axes of a unidirectional composite.

The 1-axis is along the fiber and is in the longitudinal direction. This on-axis configuration is called orthotropic.

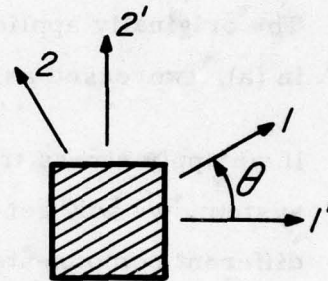

Fig. 15. Off-axis or generally orthotropic configuration of a unidirectional composite. Counterclockwise rotation of the ply orientation is positive; clockwise rotation, negative. The sign of angle of rotation is critical.

In order to evaluate the properties of an off-axis unidirectional composite; i. e., the properties in  $1'-2'$  coordinates in Fig. 15, one of the direct methods is to transform the stress from the off-axis  $1'-2'$  coordinates to the on-axis  $1-2$  coordinates. Thus, we recover the orthotropic symmetry

in this new, transformed coordinates, and can now apply the on-axis stress-strain relations developed in Section 1, such as Table 5. We can determine the induced strain from the applied stress; both stress and strain are in the 1-2 system. If we want to know what the induced strain is in the original off-axis 1'-2' system, we need only to apply the inverse transformation to the induced strain in the on-axis 1-2 system.

The sequence of operations just described can be illustrated in Fig. 16. It can be used to derive the off-axis compliance of a unidirectional composite.

- The originally applied stress to an off-axis composite is shown in (a), expressed as  $\sigma_1'$ .
- If we apply stress transformation to the components of (a) in 1'-2' system, we will get (b), the same state of stress but expressed in the different components of the on-axis 1-2 system; i. e.,  $\sigma_i$ . This positive stress transformation is designated as  $T_{\sigma}^+$ .
- Since we know the relations between stress and strain from Table 5, we can determine the induced strain in the on-axis 1-2 system,  $\epsilon_i$  which is shown in (c).
- We can then apply inverse strain transformation to get the strain components in the off-axis 1'-2' system from the on-axis 1-2 system; i. e., from (c) to (d) in Fig. 16. This negative strain transformation is designated as  $T_{\epsilon}^-$ . Then we have the induced strain in (d) as the result of applied stress in (a), both of which are in the off-axis 1'-2' system.

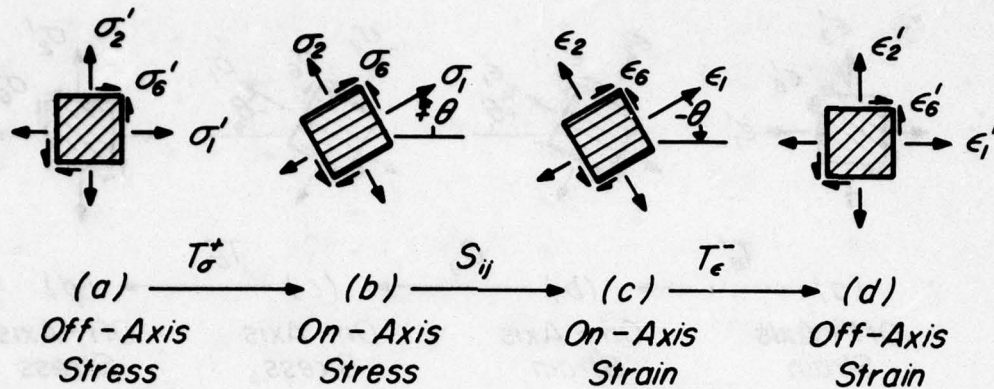

Fig. 16. Determination of the off-axis compliance:

From (a) to (b): use positive stress transformation

From (b) to (c): use the on-axis stress-strain relation in compliance.

From (c) to (d): use negative strain transformation

We can go from (a) to (d) directly if we know the off-axis stress-strain relation. This can be derived by merging the three steps in this figure into one. If imposed strain is given in Fig. 16(a) instead of stress, the induced off-axis stress can be determined by a very analogous method. The off-axis modulus of a unidirectional composite can be derived from this process. The sequence of operations is illustrated in Fig. 17.

- From off-axis strain to on-axis strain, use positive strain transformation. This is the operation from (a) to (b).
- From on-axis strain to on-axis stress, use the on-axis stress-strain relation in modulus, as in Table 6. This is the operation from (b) to (c).
- From on-axis stress to off-axis stress, use negative stress transformation. This operation is from (c) to (d).

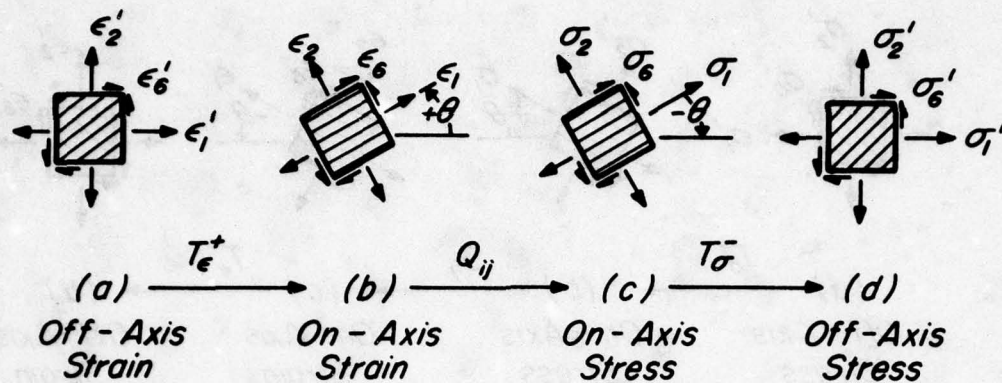

Fig. 17. Determination of the off-axis modulus:

From (a) to (b): use positive strain transformation.

From (b) to (c): use the on-axis stress-strain relations in modulus.

From (c) to (d): use negative or inverse stress transformation.

Alternatively, we can go from (a) to (d) directly if we know the off-axis modulus.

The scope of this section is to show stress and strain transformation. The formulas of the transformation are simple and easy to use, but the most critical part of the operation is the sign convention. As we have repeatedly mentioned, signs are critical for the study of composites. Such emphasis is not called for in the case of ordinary materials because their behavior is often insensitive to signs and directions.

The notations associated with coordinate transformation are arbitrary. The components of the original versus the transformed, the old versus the new, the 1'-2' versus the 1-2 systems, or the primed versus the unprimed are based on a matter of judgment, and may certainly vary from author to author and from situation to situation. Only the definition of the on-axis and the off-axis are normally fixed. The key issue is the initial definition

such as that shown in Fig. 15, where the coordinates and the ply orientation are illustrated. This definition holds only for the present situation where we are concerned with unidirectional composites. When we study the laminated plates a different definition will be used; e. g., the primed and unprimed coordinates may be changed. One definition that we will keep, however, is that the counterclockwise rotation be noted as positive.

## 2. TRANSFORMATION OF STRESS

Now we would like to derive the relations between two sets of stress components; one set expressed in the 1'-2' system, and the other in 1-2 system. The latter is rotated from the former by a positive angle as shown in Fig. 15 and repeated in Fig. 18(a). In Fig. 18(b) & (c), the two sets of stress components, one primed, the other unprimed, are also shown. The arrows indicate the direction of the positive component.

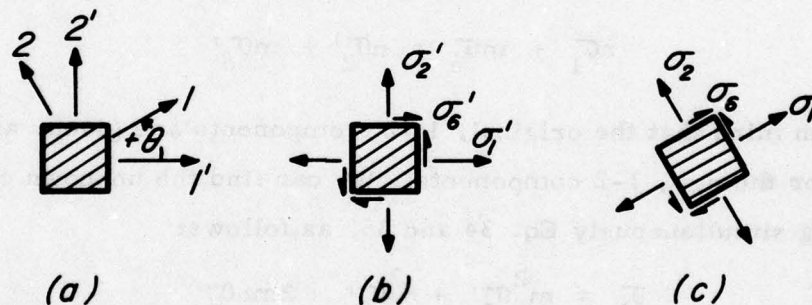

Fig. 18. Stress transformation: changes in stress components due to coordinate rotation or transformation.

(a) Relation between primed and unprimed systems.

Counterclockwise rotation is positive.

(b) Primed, off-axis stress components.

(c) Unprimed, on-axis stress components.

All arrows for the components are pointing in a positive direction.

The transformation of stress can be derived from the balance of forces. Consider a free-body diagram shown in Fig. 19(a) which is a wedge sliced across fibers in a typical infinitesimal unit area like that in Fig. 18(b). The sides of this wedge have the following lengths relative to unity hypotenuse; also shown in Fig. 19(a):

$$\begin{aligned} m &= \cos \theta \\ n &= \sin \theta \end{aligned} \quad (33)$$

The forces exerted on the sides of this triangular free body, shown only schematically in Fig. 19(b), are the products of the stress components multiplied by the appropriate lengths of the sides.

- Balance of horizontal (along the 1'-axis) forces yields:

$$m\sigma_1 - n\sigma_6 = m\sigma_1' + n\sigma_6' \quad (34)$$

- Balance of vertical (along the 2'-axis) forces yields:

$$n\sigma_1 + m\sigma_6 = n\sigma_2' + m\sigma_6' \quad (35)$$

Keeping in mind that the original, 1'-2' components are given, and we are looking for the new, 1-2 components. We can find the unknown components by solving simultaneously Eq. 34 and 35, as follows:

$$\sigma_1 = m^2\sigma_1' + n^2\sigma_2' + 2mn\sigma_6' \quad (36)$$

$$\sigma_6 = -mn\sigma_1' + mn\sigma_2' + (m^2 - n^2)\sigma_6' \quad (37)$$

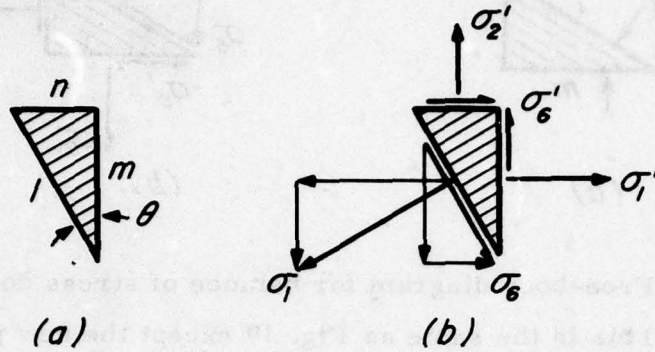

Fig. 19. Free-body diagram for the balance of stress components. The components of on-axis, 1-2 coordinates can be expressed in terms of those of the off-axis, 1'-2' coordinates. All stress components shown are positive.

We can now repeat the process by taking a different wedge by slicing parallel to fibers in the unit area as in Fig. 18(b). On this plane the normal stress component is  $\sigma_2$ . The free body diagram for this wedge is shown in Fig. 20, from which the following relations can be established:

- Balance of horizontal forces yields:

$$n\sigma_2 + m\sigma_6 = n\sigma_1' - m\sigma_6' \quad (38)$$

- Balance of vertical forces yields:

$$m\sigma_2 - n\sigma_6 = m\sigma_2' - m\sigma_6' \quad (39)$$

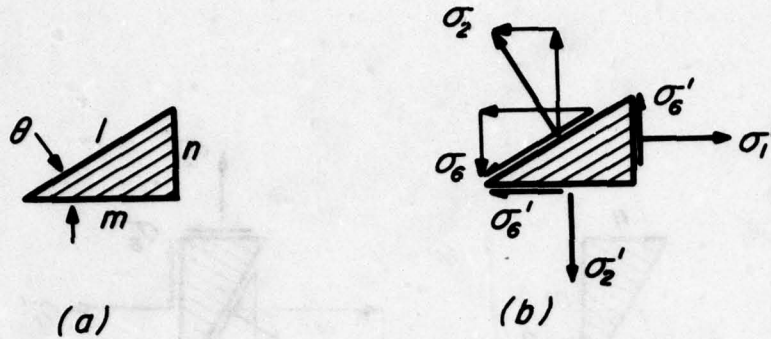

Fig. 20. Free-body diagram for balance of stress components. This is the same as Fig. 19 except the new plane is sliced along the fibers.

If we solve the last two equations simultaneously, we get

$$\sigma_2 = n^2 \sigma_1' + m^2 \sigma_2' - 2mn \sigma_6' \quad (40)$$

$$\sigma_6 = -mn \sigma_1' + mn \sigma_2' + (m^2 - n^2) \sigma_6' \quad (41)$$

Note that the shear stress expressed in Eq. 41 is the same as that in Eq. 37, as it should be. Thus, the three equations for stress transformation are Eqs. 36, 40 and 41. These equations can be packaged in a matrix multiplication table as we did in Table 4, as follows:

Table 10. STRESS TRANSFORMATION EQUATIONS IN POWER FUNCTIONS

	$\sigma_1'$	$\sigma_2'$	$\sigma_6'$
$\sigma_1$	$m^2$	$n^2$	$2mn$
$\sigma_2$	$n^2$	$m^2$	$-2mn$
$\sigma_6$	$-mn$	$mn$	$m^2 - n^2$

$$m = \cos \theta, \quad n = \sin \theta$$

The transformation equations above are expressed in terms of second power of sines and cosines. We can rewrite these equations using double angle trigonometric identities as follows:

$$\begin{aligned}
 m^2 &= \cos^2 \theta = \frac{1}{2} + \frac{1}{2} \cos 2\theta \\
 n^2 &= \sin^2 \theta = \frac{1}{2} - \frac{1}{2} \cos 2\theta \\
 2mn &= \sin 2\theta \\
 m^2 - n^2 &= \cos 2\theta
 \end{aligned}
 \tag{42}$$

When we substitute these identities into the equations in Table 10, we get

$$\begin{aligned}
 \sigma_1 &= \frac{1}{2} (\sigma_1' + \sigma_2') + \frac{1}{2} (\sigma_1' - \sigma_2') \cos 2\theta + \sigma_6' \sin 2\theta \\
 \sigma_2 &= \frac{1}{2} (\sigma_1' + \sigma_2') - \frac{1}{2} (\sigma_1' - \sigma_2') \cos 2\theta - \sigma_6' \sin 2\theta \\
 \sigma_6 &= -\frac{1}{2} (\sigma_1' - \sigma_2') \sin 2\theta + \sigma_6' \cos 2\theta
 \end{aligned}
 \tag{43}$$

Introducing a notation commonly used in photoelasticity, where

$$\begin{aligned}
 p &= \frac{1}{2} (\sigma_1 + \sigma_2), \quad q = \frac{1}{2} (\sigma_1 - \sigma_2), \quad r = \sigma_6 \\
 \text{or } p' &= \frac{1}{2} (\sigma_1' + \sigma_2'), \quad q' = \frac{1}{2} (\sigma_1' - \sigma_2'), \quad r = \sigma_6'
 \end{aligned}
 \tag{44}$$

we can now express the stress transformation equations in terms of double angles and the notation in Eq. 44. This new formulation is shown in a matrix multiplication table as follows:

Table 11. STRESS TRANSFORMATION IN DOUBLE ANGLE FUNCTIONS - I

	$p'$	$q'$	$r'$
$\sigma_1$	1	$\cos 2\theta$	$\sin 2\theta$
$\sigma_2$	1	$-\cos 2\theta$	$-\sin 2\theta$
$\sigma_6$		$-\sin 2\theta$	$\cos 2\theta$

$\theta$  is positive in counter-clockwise rotation

There is an alternative arrangement for Table 11 where the column headings and the trigonometric functions are interchanged. This arrangement is useful for certain ply orientation such as 45 degrees, in which case the column with the cosine function vanishes.

Table 12. STRESS TRANSFORMATION IN DOUBLE ANGLE FUNCTIONS - II

	1	$\cos 2\theta$	$\sin 2\theta$
$\sigma_1$	$p'$	$q'$	$r'$
$\sigma_2$	$p'$	$-q'$	$-r'$
$\sigma_6$		$r'$	$-q'$

Either table can be used. The common feature is the first column, where the influence of the angle of rotation does not exist. The constant  $p'$  is called an invariant of this coordinate transformation. If we add the first two rows of the tables above, we get

$$2p = \sigma_1 + \sigma_2 = 2p' = \sigma_1' + \sigma_2' \quad (45)$$

Thus the sum of the two normal stress components remain constant, independent of the angle of rotation or ply orientation. We call this invariant the first-order invariant for stress transformation; i. e.,

$$I = p = p' \quad (46)$$

There is a second-order invariant that we can show as follows:

From Eq. 44

$$q^2 + r^2 = \frac{1}{4} (\sigma_1 - \sigma_2)^2 + \sigma_6^2$$

From Table 12

$$\begin{aligned} &= q'^2 \cos^2 2\theta + 2q'r' \sin 2\theta \cos 2\theta + r'^2 \sin^2 2\theta \\ &+ r'^2 \cos^2 2\theta - 2q'r' \sin 2\theta \cos 2\theta + q'^2 \sin^2 2\theta \\ &= q'^2 + r'^2 \end{aligned} \quad (47)$$

This is another invariant because the quantity remains the same for any value of angle or ply orientation. We label this second-order invariant as

$$R^2 = q^2 + r^2 = q'^2 + r'^2 \quad (48)$$

where R is the radius of the Mohr circle for stress transformation. The geometric relationship of Eq. 48 is shown in Fig. 21. Also shown in this figure are the phase angle  $\theta_o$  and the following relations:

$$\left. \begin{aligned} q' &= R \cos 2\theta_o \\ r' &= R \sin 2\theta_o \end{aligned} \right\} \quad (49)$$

$$2\theta_o = \tan^{-1} \frac{r'}{q'} = \sin^{-1} \frac{r'}{R} = \cos^{-1} \frac{q'}{R}$$

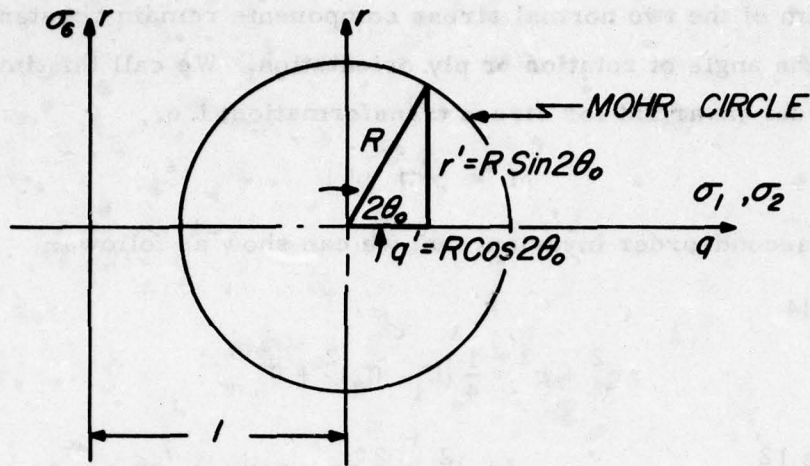

Fig. 21. Geometric relations of second-order stress invariant  $I$  and Mohr circle. This location of the center in the conventional stress coordinates is specified by the first invariant  $I$ . Thus the three stress components that characterize the state of plane stress can be represented by at least three sets of variables for a given coordinate system; i. e., for a given angle of orientation, say,  $\theta$ .

- First set:  $\sigma_1, \sigma_2, \sigma_6$ .
- Second set:  $p, q, r$ , in accordance with Eq. 44.
- Third set:  $I, R, \theta_0$ , in accordance with Eq. 46, 48 and 49.

Similarly, the stress transformation can be formulated in terms of each of the sets above. We have done the first two; the third set can be used to derive the transformation equations by substituting Eq. 46, 48 and 49 into the appropriate column headings in Table 11, the transformation in terms of  $p', q', r'$ .

$$\begin{aligned}
 \sigma_1 &= I_\sigma + R_\sigma \cos 2\theta_0 \cos 2\theta + R_\sigma \sin 2\theta_0 \sin 2\theta \\
 &= I_\sigma + R_\sigma \cos 2(\theta - \theta_0) \\
 \sigma_2 &= I_\sigma - R_\sigma \cos 2(\theta - \theta_0) \\
 \sigma_6 &= -R_\sigma \cos 2\theta_0 \sin 2\theta + R_\sigma \sin 2\theta_0 \cos 2\theta \\
 &= -R_\sigma \sin 2(\theta - \theta_0)
 \end{aligned}
 \tag{50}$$

where

$$\begin{aligned}
 I &= I_{\sigma} = \frac{1}{2} (\sigma_1' + \sigma_2') \\
 R &= R_{\sigma} = \sqrt{q'^2 + r'^2} = \sqrt{\frac{1}{4} (\sigma_1' - \sigma_2')^2 + \sigma_6'^2} \\
 2\theta_0 &= \cos^{-1} \frac{q'}{R} = \sin^{-1} \frac{r'}{R} = \tan^{-1} \frac{r'}{q'}
 \end{aligned}
 \quad (50)$$

This invariant formulation of the transformation equations can be shown in a matrix multiplication table as follows:

Table 13. STRESS TRANSFORMATION IN INVARIANT FUNCTIONS

	<i>I</i>	<i>R</i>
$\sigma_1$	<i>I</i>	$\cos 2(\theta - \theta_0)$
$\sigma_2$	<i>I</i>	$-\cos 2(\theta - \theta_0)$
$\sigma_6$		$-\sin 2(\theta - \theta_0)$

We have seen that transformation equations can be written in a set of several functions. There are advantages and disadvantages associated with each set. From the standpoint of numerical calculation, the invariant functions in Table 13 may be the easiest because there are only two columns in Table 13, instead of three in Tables 10-12. The Mohr circle representation is also based on the invariant functions. But the direction of rotation and the magnitude and the sign of the phase angle can be troublesome. Care must be exercised in applying the last line of Eq. 50 so that a mistake of 180 degree out of phase is not made. Inverse trigonometric functions are not single-valued; they repeat themselves at fixed intervals. The double angle functions of the stress transformation in Tables 11 and 12 is better in the sense that

the signs are correctly built in. The classical power functions formulation in Table 10 appears most frequently in existing textbooks. This formulation is most convenient to use when one or two of the stress components are zero; e.g., if  $\sigma_2' = \sigma_6' = 0$ .

### 3. NUMERICAL EXAMPLES OF STRESS TRANSFORMATION

#### a. Problem #1: Given stress in 1'-2' system

$$\sigma_i' = (2, 4, 6)$$

Find stress components in 1-2 system for  $\theta = 45$  degrees. The two reference coordinates are shown in Fig. 22. (Same as Fig. 18.)

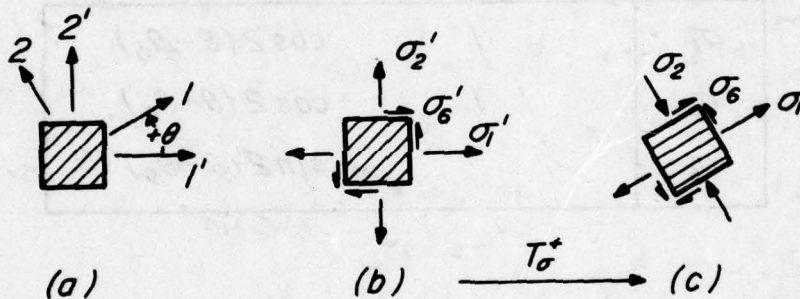

Fig. 22. Stress transformation: changes in stress components due to coordinate transformation.

Solution:

- (1) From the power function transformation in Table 10.

$$\cos \theta = \sin \theta = \sqrt{2}$$

$$\sigma_1 = \frac{1}{2} (2 + 4 + 2 \times 6) = 9$$

$$\sigma_2 = \frac{1}{2} (2 + 4 - 2 \times 6) = -3$$

$$\sigma_6 = \frac{1}{2} (-2 + 4 + 0) = 1$$

(51)

(2) From the double angle function transformation in Table 12:

$$\cos 2\theta = 0, \sin 2\theta = 1$$

$$p' = \frac{1}{2}(2 + 4) = 3$$

$$q' = \frac{1}{2}(2 - 4) = -1$$

$$r' = 6$$

(52)

Then,

$$\sigma_1 = 3 + 6 = 9$$

$$\sigma_2 = 3 - 6 = -3$$

$$\sigma_6 = 1$$

(53)

(3) From the invariant function transformation in Table 13:

$$I = p' = 3$$

$$R = 1^2 + 6^2 = \sqrt{37}$$

$$\theta_0 = \frac{1}{2} \tan^{-1} -6 = -40.269 \text{ degree}$$

$$\text{or} = \frac{1}{2} \sin^{-1} \frac{6}{\sqrt{37}} = 40.269 \text{ degree} \quad (54)$$

$$\text{or} = \frac{1}{2} \cos^{-1} \frac{-1}{\sqrt{37}} = 49.731 \text{ degree}$$

The correct answer for the phase angle is that which recovers the original given stress when  $\theta$  is zero in stress transformation in invariant functions in Table 13. Thus, using this table and the invariants in Eq. 54, the four possible states of stress, each corresponding to a phase angle, are shown in the equivalent Mohr circle in Fig. 23. Only one such state of stress is shown in Fig. 21.

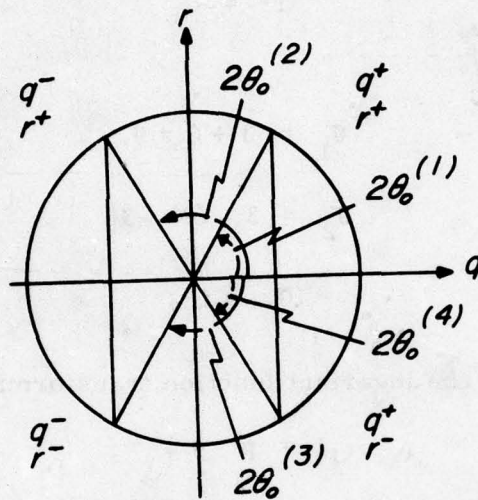

Fig. 23. Four possible states of stress. For a given Mohr circle, the sign of the stress components depend on the signs of  $q'$  and  $r'$  in Eq. 52 (primes are omitted in this figure). Each state of stress is associated with a phase angle. The four phase angles shown in this figure are related in Eq. 56.

$$\begin{aligned}
 \theta_o^{(4)} &= -40.269, \sigma_i = (4, 2, -6) \\
 \theta_o^{(1)} &= 40.269, \sigma_i = (4, 2, 6) \\
 \theta_o^{(3)} &= -49.731, \sigma_i = (2, 4, -6) \\
 \theta_o^{(2)} &= 49.731, \sigma_i = (2, 4, 6)
 \end{aligned}
 \quad \left. \vphantom{\begin{aligned} \theta_o^{(4)} \\ \theta_o^{(1)} \\ \theta_o^{(3)} \\ \theta_o^{(2)} \end{aligned}} \right\} (55)$$

Note that the last phase angle is the correct one for this present example. This difficulty of the invariant formulation is caused by the multivalued trigonometric functions. Note relationships between phase angles; e. g.,

$$\begin{aligned}
 \theta_o^{(1)} + \theta_o^{(2)} &= 90 \\
 \theta_o^{(3)} + \theta_o^{(4)} &= -90 \\
 \theta_o^{(1)} &= -\theta_o^{(4)} \\
 \theta_o^{(2)} &= -\theta_o^{(3)}
 \end{aligned}
 \quad \left. \vphantom{\begin{aligned} \theta_o^{(1)} + \theta_o^{(2)} &= 90 \\ \theta_o^{(3)} + \theta_o^{(4)} &= -90 \\ \theta_o^{(1)} &= -\theta_o^{(4)} \\ \theta_o^{(2)} &= -\theta_o^{(3)} \end{aligned}} \right\} (56)$$

Using the correct phase angle  $\theta_o^{(2)}$  and the given angle of rotation at 45 degrees, we can now determine the transformed stress components from Table 13:

$$\begin{aligned}
 \sigma_1 &= 3 + \sqrt{37} \cos 2(45 - 49.731) = 9 \\
 \sigma_2 &= 3 - \sqrt{37} \cos 2(45 - 49.731) = -3 \\
 \sigma_6 &= -\sqrt{37} \sin 2(45 - 49.731) = 1
 \end{aligned}
 \quad \left. \vphantom{\begin{aligned} \sigma_1 &= 3 + \sqrt{37} \cos 2(45 - 49.731) = 9 \\ \sigma_2 &= 3 - \sqrt{37} \cos 2(45 - 49.731) = -3 \\ \sigma_6 &= -\sqrt{37} \sin 2(45 - 49.731) = 1 \end{aligned}} \right\} (57)$$

Note that all three formulations yield the same answers, as we can see in Eq. 51, 53, and 57. In spite of the multivalued phase angles for the invariant formulation of the transformation, the phase angle has one important feature. When the angle of rotation  $\theta$  is equal to the phase angle  $\theta_o$ , from Table 13 we have:

$$\begin{aligned}
 \sigma_1 &= 3 + \sqrt{37} = 9.082 \\
 \sigma_2 &= 3 - \sqrt{37} = -3.082 \\
 \sigma_6 &= 0
 \end{aligned}
 \quad (58)$$

This orientation is called the principal direction. For in this state of stress, the shear stress is zero, and the normal stress components reach maximum and minimum values. They can be determined immediately from the two invariants:

$$\begin{aligned}\sigma_I &= \sigma_{\max} = I + R \\ \sigma_{II} &= \sigma_{\min} = I - R\end{aligned}\tag{59}$$

where stress  $\sigma_I$  and  $\sigma_{II}$  are the two principal stress components. See Fig. 24.

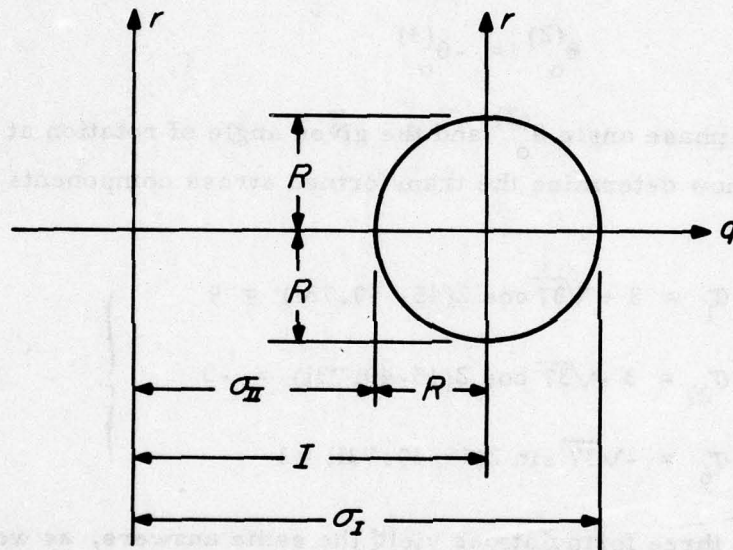

Fig. 24. Principal stress components. They are the maximum or minimum values in the Mohr circle.

Thus, the principal direction is derived from:

$$\theta - \theta_0 = 0\tag{60}$$

There is another important orientation; i. e., 45 degrees from the principal direction, or when

$$\theta - \theta_0 = 45\tag{61}$$

At this angle, we have

$$\left. \begin{aligned} \sigma_1 &= I = 3 \\ \sigma_2 &= I = 3 \\ \sigma_6 &= -R = -\sqrt{37} = -6.082 \end{aligned} \right\} \quad (62)$$

Here, both normal stress components are equal to the first invariant; the shear stress component reaches its minimum value. The latter would have been the maximum shear stress if  $-45$  is used in Eq. 61.

b. Problem #2: Given the same stress as Problems #1, i. e.,

$$\sigma_i' = (2, 4, 6) \quad (63)$$

But the direction of rotation is reversed; i. e.,  $\theta = -45$ ; see Fig. 25. This is an inverse transformation of Problem #1.

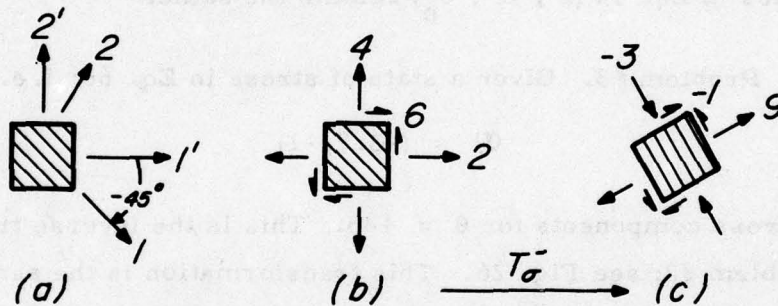

Fig. 25. Inverse stress transformation. This is identical to that in Fig. 22 except the angle of rotation is negative.

Solution:

(1) From the power function transformation in Table 10:

$$\cos \theta = \sqrt{2}, \quad \sin \theta = -\sqrt{2}$$

$$\left. \begin{aligned} \sigma_1 &= \frac{1}{2} (2 + 4 - 2 \times 6) = -3 \\ \sigma_2 &= \frac{1}{2} (2 + 4 + 2 \times 6) = 9 \\ \sigma_6 &= \frac{1}{2} (2 - 4 + 0) = -1 \end{aligned} \right\} \quad (64)$$

(2) From the double angle transformation in Table 12:

$$\cos 2\theta = 0, \sin 2\theta = -1$$

As in Problem No. 1,

$$p' = 3, q' = -1, r' = 6 \quad (65)$$

Then

$$\left. \begin{aligned} \sigma_1 &= 3 - 6 = -3 \\ \sigma_2 &= 3 + 6 = 9 \\ \sigma_6 &= -1 \end{aligned} \right\} \quad (66)$$

Note that when the angle of orientation changes sign, the normal components are interchanged, and the shear component changes sign. Although we did not show the transformation by the invariant formulation, the quantities in Eq. 54 ( $I, R, \theta_0$ ) remain the same.

c. Problem #3. Given a state of stress in Eq. 66; i.e.,

$$\sigma'_i = (-3, 9, -1) \quad (67)$$

Find the stress components for  $\theta = +45^\circ$ . This is the inverse transformation of Problem #2; see Fig. 26. This transformation is the same as Problem #1 except the original state of stress is different.

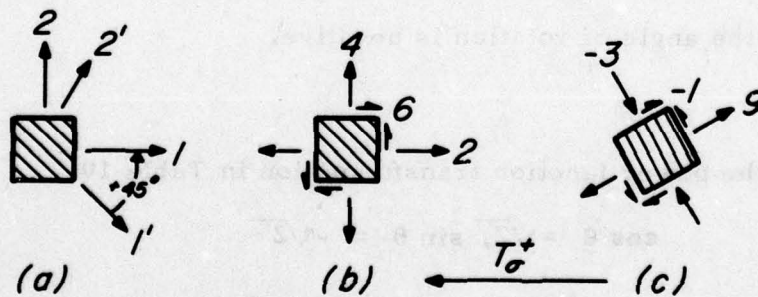

Fig. 26. Inverse stress transformation of that illustrated in Fig. 25.

**Solution:** We will use the double-angle formulation here. When  $\theta$  is +45 degrees

$$\cos 2\theta = 0, \sin 2\theta = +1$$

From Eq. 44

$$\left. \begin{aligned} p' &= \frac{1}{2}(-3 + 9) = 3 = \text{invariant} \\ q' &= \frac{1}{2}(-3 - 9) = -6 \\ r' &= -1 \end{aligned} \right\} (68)$$

From Table 12

$$\left. \begin{aligned} \sigma_1 &= 3 - 1 = 2 \\ \sigma_2 &= 3 + 1 = 4 \\ \sigma_6 &= 6 \end{aligned} \right\} (69)$$

Note that we have recovered the original stress given in Problem # 2.

As a final emphasis on the importance of the sign of angles, Fig. 27 shows the consequence of a sign error. A positive transformation from the  $1' - 2'$  axes will result in the material symmetry axes, designated  $1^+ - 2^+$  axes. A sign error will result in the  $1^- - 2^-$  axes which are  $2\theta$  orientation away from the correct answer.

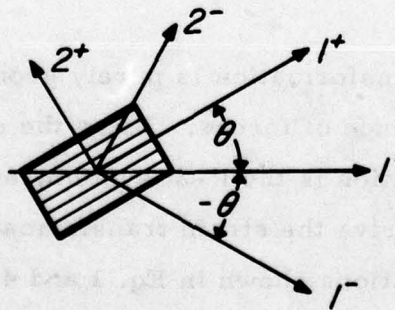

**Fig. 27.** Positive and negative angles of rotation. Guesswork is not good enough for composites. Keep track of the signs!

#### 4. TRANSFORMATION OF STRAIN

Strain transformation is as important as stress transformation. An identical figure to Fig. 18 can be drawn for the strain components. This is done in Fig. 28.

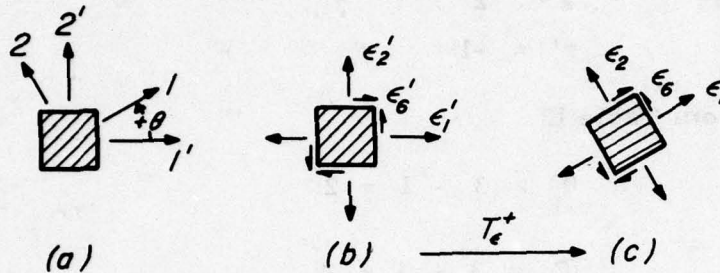

Fig. 28. Strain transformation. Changes in strain components due to coordinate rotation or transformation.

(a) Relation between primed and unprimed systems.

Counterclockwise rotation is positive.

(b) Primed, off-axis strain components.

(c) Unprimed, on-axis strain components.

All arrows for the components are pointing in a positive direction.

Like strain itself, strain transformation is purely geometric and involves no material property or balance of forces. Using the notation shown in Fig. 28, the off-axis orientation is the  $1'-2'$  system, and the on-axis, the  $1-2$  system. We will now derive the strain transformation relations from the strain-displacement relations shown in Eq. 1 and 4 and repeated as follows.

$$\begin{aligned}
 \epsilon_1 &= \frac{\partial u}{\partial x} \\
 \epsilon_2 &= \frac{\partial v}{\partial y} \\
 \epsilon_6 &= \frac{\partial v}{\partial x} + \frac{\partial u}{\partial y}
 \end{aligned}
 \tag{70}$$

Since both displacements  $u$  and  $v$  and coordinates  $x$  and  $y$  (in place of 1 and 2) are vectors, and are directionally dependent quantities, we only need to find the relationship between the primed and the unprimed components of a vector.

First, from analytic geometry, we can derive the following relations between the primed and unprimed coordinate systems as shown in Fig. 29 (a) and (b), respectively,

$$\begin{aligned}
 x &= mx' + ny' \\
 y &= -nx' + my'
 \end{aligned}
 \tag{71}$$

conversely,

$$\begin{aligned}
 x' &= mx - ny \\
 y' &= nx + my
 \end{aligned}
 \tag{72}$$

where, as before,  $m = \cos \theta$ ,  $n = \sin \theta$

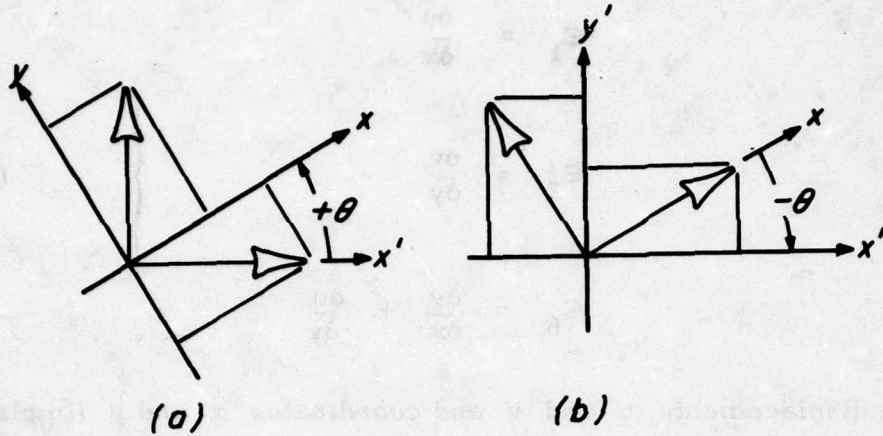

Fig. 29. Coordinate systems between the primed and unprimed axes.

(a) To go from primed to unprimed,  $\theta$  is positive.

(b) To go from unprimed to primed,  $\theta$  is negative.

From Eq. 72, we can get the following by partial differentiation:

$$\frac{\partial x'}{\partial x} = m, \frac{\partial x'}{\partial y} = -n, \frac{\partial y'}{\partial x} = n, \frac{\partial y'}{\partial y} = m \quad (73)$$

The relations between displacements in the primed and unprimed coordinates are identical to those in Eq. 71 and 72 because all quantities are vectors. We can simply write the following by replacing  $x, y, x', y'$ , by  $u, v, u', v'$ , respectively:

$$u = mu' + nv' \quad (74)$$

$$v = -nv' + mv'$$

conversely,

$$u' = mu - nv$$

$$v' = nu + mv$$

(75)

Now we are ready to derive the strain transformation equations.

From Eq. 70

$$\epsilon_1 = \frac{\partial u}{\partial x}$$

by chain differentiation

$$= \frac{\partial u'}{\partial x'} \frac{\partial x'}{\partial x} + \frac{\partial u}{\partial y'} \frac{\partial y'}{\partial x}$$

from Eq. 73 and 74

$$\begin{aligned} &= \left[ m \frac{\partial u'}{\partial x'} + n \frac{\partial v'}{\partial x'} \right] m + \left[ m \frac{\partial u'}{\partial y'} + n \frac{\partial v'}{\partial y'} \right] n \\ \epsilon_1 &= m^2 \epsilon'_1 + n^2 \epsilon'_2 + mn \epsilon'_6 \end{aligned} \quad (76)$$

where

$$\epsilon'_i = \frac{\partial u'}{\partial x'}, \quad \epsilon'_2 = \frac{\partial v'}{\partial y'}; \quad \epsilon'_6 = \frac{\partial u'}{\partial y'} + \frac{\partial v'}{\partial x'}$$

Here primes are added to all quantities in Eq. 70. We can do this because the relationship is invariant; i. e., the relationship does not change from coordinates to coordinates, and is valid for all coordinate systems. Note that the strain transformation in Eq. 76 is very similar to the stress transformation in Eq. 36 except the factor 2 is missing in the shear term. This difference comes about from the use of engineering shear strain as shown in Table 3 and Eq. 4.

By an identical process as that used in the derivation of Eq. 76, we can show

$$\epsilon_2 = n^2 \epsilon'_1 + m^2 \epsilon'_2 - mn \epsilon'_6 \quad (77)$$

$$\epsilon_6 = -2mn \epsilon'_1 + 2mn \epsilon'_2 + (m^2 - n^2) \epsilon'_6 \quad (78)$$

This is summarized in a matrix multiplication table as follows:

Table 14. STRAIN TRANSFORMATION EQUATIONS IN POWER FUNCTIONS

	$\epsilon_1'$	$\epsilon_2'$	$\epsilon_6'$
$\epsilon_1$	$m^2$	$n^2$	$mn$
$\epsilon_2$	$n^2$	$m^2$	$-mn$
$\epsilon_6$	$-2mn$	$2mn$	$m^2 - n^2$

We can express the transformation relations in terms of double angle and invariant functions like we did for the stress transformation. Comparable to Tables 11 and 12 for stress transformation, we have for strain transformation in double angle functions shown in Tables 15 and 16, respectively.

Table 15. STRAIN TRANSFORMATION IN DOUBLE ANGLE FUNCTIONS - I

	$p'$	$q'$	$r'$
$\epsilon_1$	1	$\cos 2\theta$	$\sin 2\theta$
$\epsilon_2$	1	$-\cos 2\theta$	$-\sin 2\theta$
$\epsilon_6$		$-2\sin 2\theta$	$2\cos 2\theta$

Table 16. STRAIN TRANSFORMATION IN  
DOUBLE ANGLE FUNCTIONS - II

	$l$	$\cos 2\theta$	$\sin 2\theta$
$\epsilon_1$	$p'$	$q'$	$r'$
$\epsilon_2$	$p'$	$-q'$	$-r'$
$\epsilon_6$		$2r'$	$-2q'$

where  $p' = \frac{1}{2} (\epsilon'_1 + \epsilon'_2)$ ,  $q' = \frac{1}{2} (\epsilon'_1 - \epsilon'_2)$ ,  $r' = \frac{1}{2} \epsilon'_6$  (79)

Note that the definition of  $r'$  is different from that for the stress transformation in Eq. 44. The use of engineering shear strain is responsible for the difference.

The invariant function comparable to Table 13 for the stress transformation can be derived in a similar fashion and the results are listed in a matrix multiplication table as follows:

Table 17. STRAIN TRANSFORMATION IN INVARIANT FUNCTIONS

	$I$	$R$
$\epsilon_1$	$1$	$\cos 2(\theta - \theta_0)$
$\epsilon_2$	$1$	$-\cos 2(\theta - \theta_0)$
$\epsilon_6$		$-2\sin 2(\theta - \theta_0)$

where:

$$I = I_{\epsilon} = \frac{1}{2} (\epsilon_1' + \epsilon_2')$$

$$R = R_{\epsilon} = \sqrt{q'^2 + r'^2} = \sqrt{\frac{1}{4} (\epsilon_1' - \epsilon_2')^2 + \frac{1}{4} \epsilon_6'^2} \quad \left. \vphantom{\begin{matrix} I \\ R \end{matrix}} \right\} (80)$$

$$2\theta_0 = \cos^{-1} \frac{q'}{R} = \sin^{-1} \frac{r'}{R} = \tan^{-1} \frac{r'}{q'}$$

The advantages and disadvantages of each formulation for the strain transformation are similar to those for the stress transformation. The double angle formulation appears to provide the best compromise and is recommended for general usage. This will be our choice for the balance of this book.

5. NUMERICAL EXAMPLES OF STRAIN TRANSFORMATION

a. Problem 1. Given a state of strain in  $1' - 2'$  system

$$\epsilon_i' = (2, 4, 6)$$

Find transformed strain for  $\theta$  equal to 45 degrees. See Fig. 30.

Solution: From Table 16,  $\cos 2\theta = 0$ ,  $\sin 2\theta = 1$

$$p' = (2 + 4)/2 = 3$$

$$q' = (2 - 4)/2 = -1 \quad (81)$$

$$r' = 6/2 = 3$$

Then  $\epsilon_1 = 3 + 3 = 6$

$$\epsilon_2 = 3 - 3 = 0 \quad (82)$$

$$\epsilon_6 = -2 \times (-1) = 2$$

Note that the transformed strain is quite different from the transformed stress of (9, -3, 1) from Eq. 53. The factor of 2 in the engineering shear strain is responsible for this dramatic difference.

b. Problem 2. Try inverse transformation; for strain in Eq. 82

$$\epsilon_i' = (6, 0, 2)$$

Find strain at -45 degree rotation.

Solution: From Table 16,  $\cos 2\theta = 0$ ,  $\sin 2\theta = -1$

$$p' = (6 + 0)/2 = 3$$

$$q' = (6 - 0)/2 = 3 \quad (83)$$

$$r' = 2/2 = 1$$

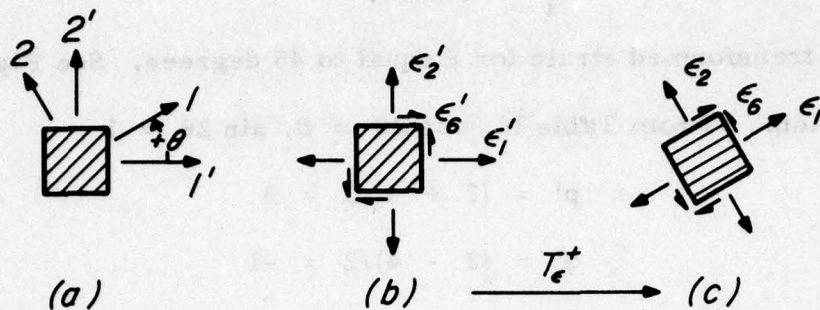

Fig. 30. Strain transformation. To go from (b) to (c) is a positive transformation when the angle of rotation is positive, as in Problem #1. The negative or inverse transformation in Problem #2 is in effect when the angle is negative. (This figure is the same as Fig. 28.)

Then

$$\epsilon_1 = 3 - 1 = 2$$

$$\epsilon_2 = 3 + 1 = 4 \quad (84)$$

$$\epsilon_6 = 2 \times 3 = 6$$

Note that the original strain is recovered.

c. **Problem 3: Strain rosettes record normal strain components in several directions. Because there are three strain components in a given 2-dimensional state of stress, we need a minimum of three independent normal strain readings in order to define the strain state. Thus, any three or more orientations of the strain rosette can completely determine the desired strain state. Four-element rosettes spaced at 45 degrees apart are often used. This arrangement provides a redundant element for crosschecking, and insuring against a defective or malfunctioning element. The strain transformation equations of Table 16 are needed for analyzing the recorded normal strain components.**

**Solution: Using superscript to denote rosette orientation, we have from the first row of Table 16.**

$$\begin{aligned}
 \epsilon^0 &= p + q \\
 \epsilon^{90} &= p - q \\
 \epsilon^{45} &= p + r \\
 \epsilon^{-45} &= p - r
 \end{aligned}
 \tag{85}$$

There are four equations for three unknowns, p, q, r, such that

$$\begin{aligned}
 p &= (\epsilon^0 + \epsilon^{90})/2 = (\epsilon^{45} + \epsilon^{-45})/2 \\
 q &= (\epsilon^0 - \epsilon^{90})/2 \\
 r &= (\epsilon^{45} - \epsilon^{-45})/2
 \end{aligned}
 \tag{86}$$

Once we know these values, we can place them in appropriate columns in Table 15 from which we can calculate the strain components for any orientation. Any one of the four elements can fail without affecting the uniqueness of the solution in Eq. 86. If for example the -45 degree element failed, the relationship in the last equation must be altered as follows:

$$r = 2\epsilon^{45} - \epsilon^0 - \epsilon^{90}
 \tag{87}$$

### SECTION III

## OFF-AXIS STIFFNESS OF UNIDIRECTIONAL COMPOSITES

### SCOPE

The stiffness of unidirectional composites with off-axis ply orientation are important because composite laminates normally consist of many off-axis plies in addition to on-axis plies. We must know how to determine the contribution to the laminate stiffness by each ply or ply assembly. We will need the transformation of modulus and compliance to determine the off-axis stiffness. These transformation relations can be formulated in terms of power functions, the multiple angle functions and the invariants. Specific examples of a graphite-epoxy composite are used to enhance understanding of the off-axis stiffness of unidirectional composites. The key relation of this and subsequent sections is the modulus transformation equation. The multiple angle formulation of the transformation is:

	$U_1$	$U_2$	$U_3$
$Q'_{11}$	$U_1$	$\cos 2\theta$	$\cos 4\theta$
$Q'_{22}$	$U_1$	$-\cos 2\theta$	$\cos 4\theta$
$Q'_{12}$	$U_4$		$-\cos 4\theta$
$Q'_{66}$	$U_5$		$-\cos 4\theta$
$Q'_{16}$		$\frac{1}{2} \sin 2\theta$	$\sin 4\theta$
$Q'_{26}$		$\frac{1}{2} \sin 2\theta$	$-\sin 4\theta$

## PRINCIPAL NOMENCLATURE

- $E_1, E_2$  = Young's modulus along and transverse to an off-axis direction, respectively.
- $I_1, I_2$  = Linear or first order invariants of modulus or compliance.
- $m$  =  $\cos \theta$
- $n$  =  $\sin \theta$
- $Q_{ij}$  = Components of modulus;  $i, j = 1, 2, 6$ .
- $R_1, R_2$  = Quadratic or second order invariants of modulus or compliance.
- $S_{ij}$  = Components of compliance;  $i, j = 1, 2, 6$ .
- $U_i$  = Linear combinations of modulus and compliance in multiple-angle formulation. Same notation but different definition is used for modulus and compliance.
- $\sigma_i$  = Components of stress;  $i = 1, 2, 6$ .
- $\sigma'_i$  = Transformed components of stress;  $i = 1, 2, 6$ .
- $\epsilon_i$  = Components of strain;  $i = 1, 2, 6$ .
- $\epsilon'_i$  = Transformed components of strain;  $i = 1, 2, 6$ .
- $\nu_{12}$  = Major Poisson's ratio along an off-axis orientation.
- $\Delta$  = Determinant of modulus or compliance.

## 1. OFF-AXIS MODULUS

As we have shown in Fig. 17 and repeated here in Fig. 31, the off-axis modulus can be determined in three steps: the off-axis to on-axis strain transformation, the on-axis stress-strain relations, and the inverse or the on-axis to off-axis stress transformation. This process was initiated by a given strain in Fig. 31(a) and led us eventually to the induced stress in Fig. 31(d). The off-axis compliance can be similarly derived in three steps, as shown in Fig. 16. The purpose here is to derive the off-axis modulus and the off-axis stress-strain relation for this arbitrary angle of orientation. Then we can go directly from (a) to (d) in Fig. 31 in one step.

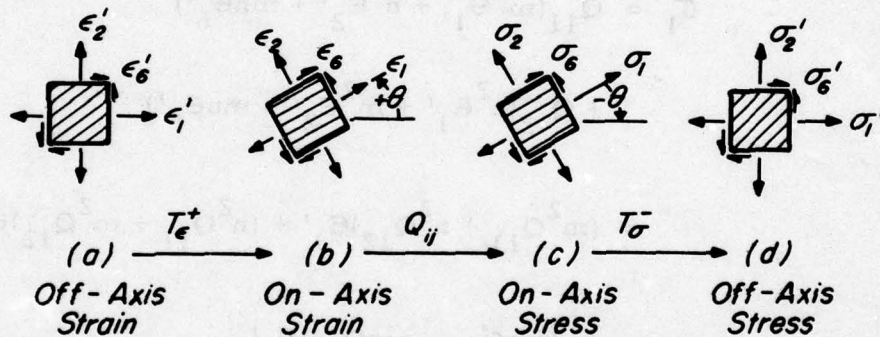

Fig. 31. Determination of the off-axis modulus:

From (a) to (b): use positive strain transformation.

From (b) to (c): use the on-axis stress-strain relations in modulus.

From (c) to (d): use negative or inverse stress transformation.

We can go from (a) to (d) directly if we merge these three steps into one. This is the same as Fig. 17.

We will follow these steps in Fig. 31.

- To go from (a) to (b), we need the strain transformation listed in Table 14, repeated here as follows:

$$\left. \begin{aligned} \epsilon_1 &= m^2 \epsilon_1' + n^2 \epsilon_2' + mn \epsilon_6' \\ \epsilon_2 &= n^2 \epsilon_1' + m^2 \epsilon_2' - mn \epsilon_6' \\ \epsilon_6 &= -2mn \epsilon_1' + 2mn \epsilon_2' + (m^2 - n^2) \epsilon_6' \end{aligned} \right\} \quad (88)$$

- To go from (b) to (c) in Fig. 31, we need the on-axis, orthotropic stress-strain relation in modulus in Table 6, which when combined with the results in Eq. 88 produces:

$$\begin{aligned} \sigma_1 &= Q_{11}(m^2 \epsilon_1' + n^2 \epsilon_2' + mn \epsilon_6') \\ &\quad + Q_{12}(n^2 \epsilon_1' + m^2 \epsilon_2' - mn \epsilon_6') \\ &= (m^2 Q_{11} + n^2 Q_{12}) \epsilon_1' + (n^2 Q_{11} + m^2 Q_{12}) \epsilon_2' \\ &\quad + (mn Q_{11} - mn Q_{12}) \epsilon_6' \end{aligned} \quad (89)$$

Similarly, 
$$\begin{aligned} \sigma_2 &= (m^2 Q_{12} + n^2 Q_{22}) \epsilon_1' + (n^2 Q_{12} + m^2 Q_{22}) \epsilon_2' \\ &\quad + (mn Q_{12} - mn Q_{22}) \epsilon_6' \end{aligned} \quad (90)$$

$$\sigma_6 = -2mn Q_{66} \epsilon_1' + 2mn Q_{66} \epsilon_2' + (m^2 - n^2) Q_{66} \epsilon_6' \quad (91)$$

- To go from (c) to (d) in Fig. 31, we need inverse or negative stress transformation as listed in Table 10. The angle of rotation is now negative, however, and the primed and unprimed are

interchanged. The unprimed is now the old (before transformation), and the primed is now the new (after transformation).

$$\begin{aligned}
 \sigma_1' &= m^2\sigma_1 + n^2\sigma_2 - 2mn\sigma_6 \\
 &= m^2 \left[ (m^2Q_{11} + n^2Q_{12})\epsilon_1' + (n^2Q_{11} + m^2Q_{12})\epsilon_2' \right. \\
 &\quad \left. + (mnQ_{11} - mnQ_{12})\epsilon_6' \right] \\
 &+ n^2 \left[ (m^2Q_{12} + n^2Q_{22})\epsilon_1' + (n^2Q_{12} + m^2Q_{22})\epsilon_2' \right. \\
 &\quad \left. + (mnQ_{12} - mnQ_{22})\epsilon_6' \right] \\
 &- 2mn \left[ -2mnQ_{66}\epsilon_1' + 2mnQ_{66}\epsilon_2' + (m^2 - n^2)Q_{66}\epsilon_6' \right] \\
 &= \left[ m^4Q_{11} + n^4Q_{22} + 2m^2n^2Q_{12} + 4m^2n^2Q_{66} \right] \epsilon_1' \\
 &+ \left[ m^2n^2Q_{11} + m^2n^2Q_{22} + (m^4 + n^4)Q_{12} - 4m^2n^2Q_{66} \right] \epsilon_2' \\
 &+ \left[ m^3nQ_{11} - mn^3Q_{22} + (mn^3 - m^3n)Q_{12} + 2(mn^3 - m^3n)Q_{66} \right] \epsilon_6' \\
 \sigma_1' &= Q_{11}'\epsilon_1' + Q_{12}'\epsilon_2' + Q_{16}'\epsilon_6' \tag{92}
 \end{aligned}$$

$$\text{Similarly, } \sigma_2' = Q_{21}'\epsilon_1' + Q_{22}'\epsilon_2' + Q_{26}'\epsilon_6' \tag{93}$$

$$\sigma_6' = Q_{61}'\epsilon_1' + Q_{62}'\epsilon_2' + Q_{66}'\epsilon_6' \tag{94}$$

This is the off-axis stress-strain relation that directly relates the given strain in Fig. 31 (a) to the resulting stress in 31(d), and redrawn in Fig. 32. This relation can also be arranged in a matrix multiplication table as follows:

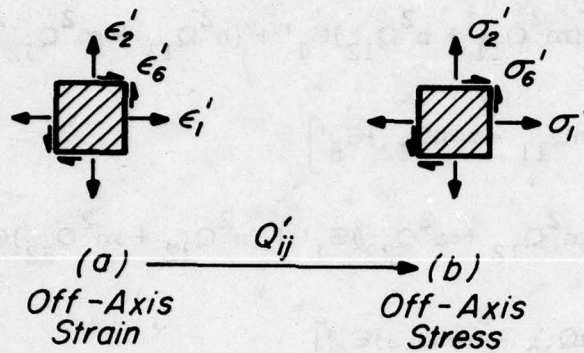

Fig. 32. The off-axis stress-strain relations in modulus. We have merged the three steps in Fig. 31 into one. The relationship remains valid if all primes are omitted in this figure. This new unprimed applies to the coordinates of Fig. 33.

Table 18. OFF-AXIS STRESS-STRAIN RELATION FOR UNIDIRECTIONAL COMPOSITES IN TERMS OF MODULUS

	$\epsilon'_1$	$\epsilon'_2$	$\epsilon'_6$
$\sigma'_1$	$Q'_{11}$	$Q'_{12}$	$Q'_{16}$
$\sigma'_2$	$Q'_{21}$	$Q'_{22}$	$Q'_{26}$
$\sigma'_6$	$Q'_{61}$	$Q'_{62}$	$Q'_{66}$

Since the choice of the primed and unprimed notation is arbitrary, this table remains valid if all primes are eliminated. Then the relation applies to the unprimed coordinates shown in Fig. 33.

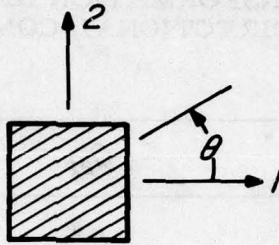

Fig. 33. A new, unprimed coordinate system. Unprimed coordinates are now the off-axis configuration. This is different from Fig. 15. This coordinate system is used for multidirectional laminates.

The major difference between the on-axis stress-strain relation in Table 6 and the off-axis relation in Table 18 lies in the additional components in the modulus. These subscripts 16 and 26 components are shear coupling terms that relate the shear strain to normal stress, or normal strain to shear stress. Such coupling does not exist in ordinary materials, or in unidirectional composites in their on-axis orientation. Geometric illustration of the shear coupling effects will be done when we develop the generally orthotropic compliance. Symmetry of these components can also be demonstrated in a manner similar to that used for the  $Q_{12}$  component in Section 1. The stored energy in Eq. 17 must contain interaction terms of  $\sigma_1 \sigma_6$  and  $\sigma_2 \sigma_6$ , or their equivalent strain components  $\epsilon_1 \epsilon_6$  and  $\epsilon_2 \epsilon_6$ .

The relationship between the modulus components of the on-axis and the off-axis orientations can be summarized in Table 19, where matrix

multiplication is implied. These relations result from the derivation of Eq. 92 and what was omitted in Eq. 93 and 94. These relations are limited to transformation from the on-axis, orthotropic orientation where shear coupling components are zero. Note that  $Q_{16}$  and  $Q_{26}$  do not appear as column headings in this table.\*

Table 19. TRANSFORMATION OF MODULUS FROM ON-AXIS UNIDIRECTIONAL COMPOSITES IN POWER FUNCTIONS

	$Q_{11}$	$Q_{22}$	$Q_{12}$	$Q_{66}$
$Q'_{11}$	$m^4$	$n^4$	$2m^2n^2$	$4m^2n^2$
$Q'_{22}$	$n^4$	$m^4$	$2m^2n^2$	$4m^2n^2$
$Q'_{12}$	$m^2n^2$	$m^2n^2$	$m^4+n^4$	$-4m^2n^2$
$Q'_{66}$	$m^2n^2$	$m^2n^2$	$-2m^2n^2$	$m^2-n^2$
$Q'_{16}$	$m^3n$	$-mn^3$	$mn^3-m^3n$	$2(mn^3-m^3n)$
$Q'_{26}$	$mn^3$	$-m^3n$	$m^3n-mn^3$	$2(m^3n-mn^3)$

$$m = \cos \theta, n = \sin \theta$$

Note that all the sums of exponents of the trigonometric functions in this table are in the fourth power which are by definition characteristic of the 4th rank tensor. The stress transformation equations are governed by the 2nd power functions, as we have shown in Table 10, and belong to the 2nd rank tensor. The strain transformation equations in Table 14 are also governed by 2nd power functions, but are different from those for stress because engineering shear strain is used which is twice the tensorial shear strain.

The critical issue again is the sign convention. The angle used in this table is the ply orientation. Because of its importance, Fig. 15 and 33 are

\*If the transformation is from one off-axis orientation to another, additional columns for  $Q_{16}$  and  $Q_{26}$  must be present.

shown here again for emphasis. Although the primed versus unprimed coordinates may be interchanged from situation to situation, it is imperative that the sign convention is clearly understood. For unidirectional composites, the on-axis, orthotropic, and material symmetry axes coincide. We normally use the unprimed axes to denote this configuration. The off-axis, generally orthotropic configuration refers to ply orientations other than 0 or 90 degrees. We normally use the primed axes for the off-axis situation. This is shown in Fig. 34(a). But for multidirectional laminates, there can be many ply orientations. So a new system of coordinates is more convenient. The 1-2 axes are some reference coordinates for the laminate. Each ply orientation  $\theta_i$  can be designated by  $1_i-2_i$  axes. The angle used in Table 19 is that shown in Fig. 34(a). This sign convention is not used universally. Some authors define ply orientation opposite to that shown in Fig. 34(a). Then their transformation relations will be different from those shown in Table 19. In particular, any term that has the odd power of sines ( $n$  and  $n^3$ ) must change its sign. Only the shear coupling terms  $Q_{16}$  and  $Q_{26}$  are affected.

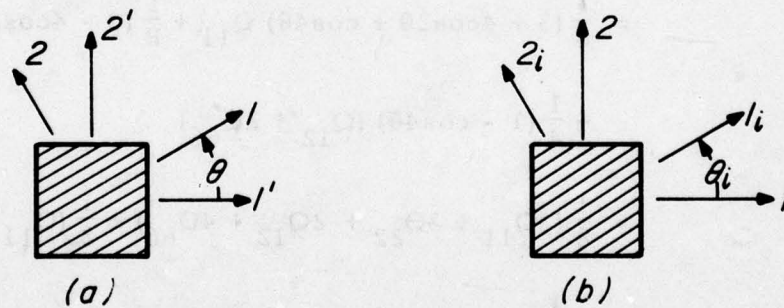

Fig. 34. Positive ply orientation is shown. The notation for unidirectional composites normally follows that in (a); that for multidirectional composites, in (b) where  $\theta_i$  is the orientation of the  $i$ -th ply or ply assembly. Primes have been deleted.

We can further develop a multiple-angle formulation for the modulus transformation in place of the power functions in Table 19. This process

can be done directly by substituting the following trigonometric identities into Table 19:

$$\begin{aligned}
 m^4 &= \frac{1}{8} (3 + 4\cos 2\theta + \cos 4\theta) \\
 m^3 n &= \frac{1}{8} (2\sin 2\theta + \sin 4\theta) \\
 m^2 n^2 &= \frac{1}{8} (1 - \cos 4\theta) \\
 mn^3 &= \frac{1}{8} (2\sin 2\theta - \sin 4\theta) \\
 n^4 &= \frac{1}{8} (3 - 4\cos 2\theta + \cos 4\theta)
 \end{aligned} \tag{95}$$

We will now show three examples of the substitution of values from Eq. 95 into Table 19:

$$\begin{aligned}
 Q'_{11} &= m^4 Q_{11} + n^4 Q_{22} + 2m^2 n^2 (Q_{12} + 2Q_{66}) \\
 &= \frac{1}{8} (3 + 4\cos 2\theta + \cos 4\theta) Q_{11} + \frac{1}{8} (3 - 4\cos 2\theta + \cos 4\theta) Q_{22} \\
 &\quad + \frac{1}{4} (1 - \cos 4\theta) (Q_{12} + 2Q_{66}) \\
 &= \frac{1}{8} (3Q_{11} + 3Q_{22} + 2Q_{12} + 4Q_{66}) + \frac{1}{2} (Q_{11} - Q_{22}) \cos 2\theta \\
 &\quad + \frac{1}{8} (Q_{11} + Q_{22} - 2Q_{12} - 4Q_{66}) \cos 4\theta \\
 &= U_1 + U_2 \cos 2\theta + U_3 \cos 4\theta \tag{96}
 \end{aligned}$$

$$\begin{aligned}
 Q'_{12} &= m^2 n^2 (Q_{11} + Q_{22} - 4Q_{66}) + (m^4 + n^4) Q_{12} \\
 &= \frac{1}{8} (1 - \cos 4\theta) (Q_{11} + Q_{22} - 4Q_{66}) + \frac{1}{8} (6 + 2\cos 4\theta) Q_{12} \\
 &= \frac{1}{8} (Q_{11} + Q_{22} + 6Q_{12} - 4Q_{66}) - \frac{1}{8} (Q_{11} + Q_{22} - 2Q_{12} - 4Q_{66}) \cos 4\theta \\
 &= U_4 - U_3 \cos 4\theta \tag{97}
 \end{aligned}$$

$$\begin{aligned}
Q'_{16} &= m^3 n Q_{11} - mn^3 Q_{22} + (mn^3 - m^3 n)(Q_{12} + 2Q_{66}) \\
&= \frac{1}{8}(2\sin 2\theta + \sin 4\theta)Q_{11} - \frac{1}{8}(2\sin 2\theta - \sin 4\theta)Q_{22} - \frac{1}{4}\sin 4\theta(Q_{12} + 2Q_{66}) \\
&= \frac{1}{8}(2Q_{11} - 2Q_{22})\sin 2\theta + \frac{1}{8}(Q_{11} + Q_{22} - 2Q_{12} - 4Q_{66})\sin 4\theta \\
&= \frac{1}{2}U_2 \sin 2\theta + U_3 \sin 4\theta \tag{98}
\end{aligned}$$

We can repeat the process for the other three components of the off-axis modulus and list the results in Table 20 in matrix multiplication format and using the following definitions of the linear combinations of modulus  $U_i$ :

$$\begin{aligned}
U_1 &= \frac{1}{8}(3Q_{11} + 3Q_{22} + 2Q_{12} + 4Q_{66}) \\
U_2 &= \frac{1}{2}(Q_{11} - Q_{22}) \\
U_3 &= \frac{1}{8}(Q_{11} + Q_{22} - 2Q_{12} - 4Q_{66}) \\
U_4 &= \frac{1}{8}(Q_{11} + Q_{22} + 6Q_{12} - 4Q_{66}) \\
U_5 &= \frac{1}{8}(Q_{11} + Q_{22} - 2Q_{12} + 4Q_{66}) \tag{99}
\end{aligned}$$

Table 20. TRANSFORMED MODULUS FROM ON-AXIS UNIDIRECTIONAL COMPOSITES IN MULTIPLE-ANGLE FUNCTIONS

	$U_1$	$U_2$	$U_3$
$Q'_{11}$	$U_1$	$\cos 2\theta$	$\cos 4\theta$
$Q'_{22}$	$U_1$	$-\cos 2\theta$	$\cos 4\theta$
$Q'_{12}$	$U_4$		$-\cos 4\theta$
$Q'_{66}$	$U_5$		$-\cos 4\theta$
$Q'_{16}$		$\frac{1}{2} \sin 2\theta$	$\sin 4\theta$
$Q'_{26}$		$\frac{1}{2} \sin 2\theta$	$-\sin 4\theta$

From the transformation equations in Table 20, we can show the off-axis combinations listed in Eq. 99 are:

$$U'_1 = \frac{1}{8}(3Q'_{11} + 3Q'_{22} + 2Q'_{12} + 4Q'_{66})$$

From Table 20:

$$= \frac{1}{8}(6U_1 + 2U_4 + 4U_5)$$

From Eq. 99:

$$\begin{aligned} &= \frac{1}{64} [(18Q_{11} + 18Q_{22} + 12Q_{12} + 24Q_{66}) + (2Q_{11} + 2Q_{22} + \\ &\quad 12Q_{12} - 8Q_{66}) + (4Q_{11} + 4Q_{22} - 8Q_{12} + 16Q_{66})] \\ &= \frac{1}{64} [24Q_{11} + 24Q_{22} + 16Q_{12} + 32Q_{66}] \\ &= \frac{1}{8} [3Q_{11} + 3Q_{22} + 2Q_{12} + 4Q_{66}] \\ &= U_1 \end{aligned} \tag{100}$$

Similarly  $U'_2 = U_2 \cos 2\theta$

$$U'_3 = U_3 \cos 4\theta$$

(101)

$$U'_4 = U_4$$

$$U'_5 = U_5$$

When the off-axis and on-axis combinations are equal, they are by definition invariant. This is analogous to the stress invariants in Eq. 46. Note that  $U_1$ ,  $U_2$ , and  $U_3$  are first-order or linear invariants, of which two are independent because we can show from Eq. 99 that

$$2U_5 = U_1 - U_4 \tag{102}$$

We have shown that stress and strain possess a second-order or quadratic invariant each; i. e., the radius of Mohr circle. The modulus also possesses second-order invariants. They can be derived as follows. We will first define two additional linear combinations for the modulus.

$$U'_6 = \frac{1}{2}(Q'_{16} + Q'_{26}) = \frac{1}{2}U_2 \sin 2\theta \quad (103)$$

$$U'_7 = \frac{1}{2}(Q'_{16} - Q'_{26}) = U_3 \sin 4\theta$$

We can now derive two second-order invariants as follows:

$$\begin{aligned} R_1^2 &= U_2'^2 + 4U_6'^2 \\ &= U_2^2(\cos^2 2\theta + \sin^2 2\theta) \\ &= U_2^2 \end{aligned}$$

$$\text{or} \quad R_1 = \pm U_2 \quad (104)$$

Similarly,

$$\begin{aligned} R_2^2 &= U_5'^2 + U_7'^2 \\ &= U_3^2(\cos^2 4\theta + \sin^2 4\theta) \\ &= U_3^2 \end{aligned}$$

$$\text{or} \quad R_2 = \pm U_3 \quad (105)$$

where  $R_1$  and  $R_2$  are invariants and  $U_2$  and  $U_3$  are not, the values of  $U_2$  and  $U_3$  stated in Eq. 99 are based on on-axis orientation for which the shear coupling terms are zero. The  $R$ 's are radii of the equivalent Mohr circle for the stress. They must always be positive. The  $U_i$  can be positive or negative. In fact,  $U_2$  would be negative if the longitudinal and transverse directions are interchanged. The correct sign in Eq. 104 and 105 must be picked to make  $R_1$  and  $R_2$  positive.

We can derive the transformation equations for modulus in terms of invariants like we did for stress and strain transformations and shown in Tables 13 and 17. If we limit ourselves to transformed modulus from the material symmetry or orthotropic axes, the results will be identical to those shown in Table 20; in which case, positive values of  $U_2$  and  $U_3$  are assigned to  $R_1$  and  $R_2$ , respectively. This is done in Table 21, where matrix multiplication is implied.

Table 21. TRANSFORMED MODULUS FROM ON-AXIS UNIDIRECTIONAL COMPOSITES IN INVARIANT FUNCTIONS

	$I$	$R_1$	$R_2$
$Q'_{11}$	$U_1$	$\cos 2\theta$	$\cos 4\theta$
$Q'_{22}$	$U_1$	$-\cos 2\theta$	$\cos 4\theta$
$Q'_{12}$	$U_4$		$-\cos 4\theta$
$Q'_{66}$	$U_5$		$-\cos 4\theta$
$Q'_{16}$		$\frac{1}{2} \sin 2\theta$	$\sin 4\theta$
$Q'_{26}$		$\frac{1}{2} \sin 2\theta$	$-\sin 4\theta$

This table is valid for the 1-axis to be pointed along the fiber orientation, like that in Fig. 14 or 34(a).

## 2. EXAMPLES OF OFF-AXIS MODULUS

We will show in this section the transformed modulus for a graphite-epoxy composite. The particular material system that we are going to use is the Union Carbide and Toray T300 filament and Narmco 5208 resin, or T300/5208 for short. The modulus data for this material were listed in Table 9. We can immediately calculate the transformed modulus by substituting the data into the transformation equations in Table 19. Numerical data for the transformed modulus are listed in Table 22 and plotted in Fig. 35. All six transformed components of the modulus are shown. The angle of ply orientation is also shown, where counterclockwise direction is positive.

Table 22. TRANSFORMED MODULUS OF T300/5208 UNIDIRECTIONAL COMPOSITES (GPa)

$\theta$	$Q'_{11}$	$Q'_{22}$	$Q'_{12}$	$Q'_{66}$	$Q'_{16}$	$Q'_{26}$
0	181.8	10.3	2.90	7.17	0	0
15	160.4	11.9	12.75	17.05	38.50	4.36
30	109.3	23.6	32.46	36.78	54.19	20.05
45	56.6	56.6	42.32	46.59	42.87	42.87
60	23.6	109.3	32.46	36.78	20.05	54.19
75	11.9	160.4	12.75	17.05	4.36	38.50
90	10.3	181.8	2.90	7.17	0	0

An alternative method of arriving at the same transformed modulus is the use of the multiple-angle or the invariant formulation in Table 20 or 21, respectively. We must first determine the values of the  $U_i$  using Eq. 99 and data in Table 9. The results of several unidirectional composites including T300/5208 are listed in Table 23. A typical calculation is listed as follows:

$$\text{From Eq. 99} \quad U_1 = \frac{1}{8}(3Q_{11} + 3Q_{22} + 2Q_{12} + 4Q_{66})$$

$$\text{From Table 9} \quad U_1 = \frac{1}{8}(3 \times 181.8 + 3 \times 10.34 + 2 \times 2.897 + 4 \times 7.17)$$

$$= 76.37 \text{ GPa}$$

(106)

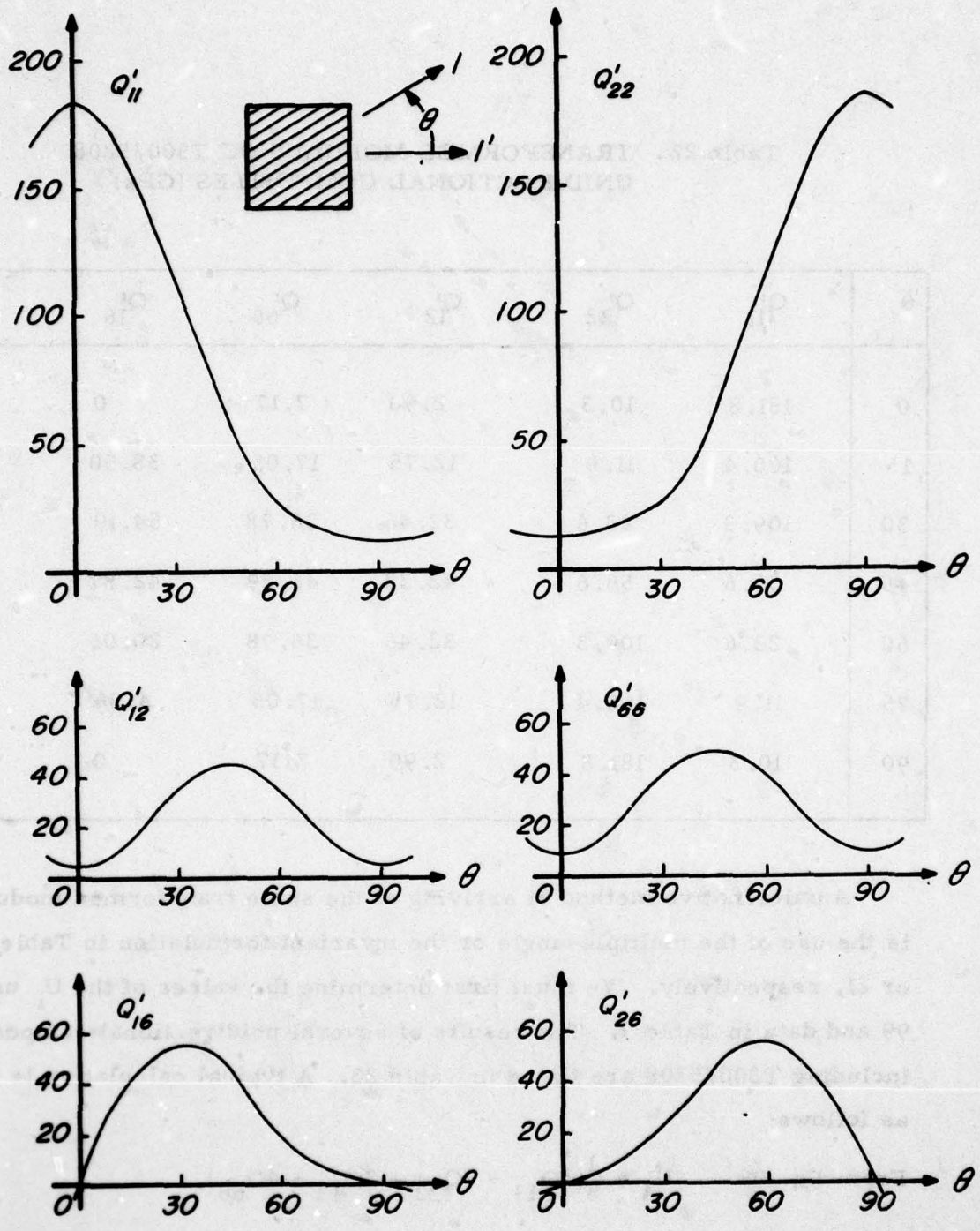

Fig. 35. Transformed, off-axis modulus of T300/5208. The angle is the ply orientation, and is positive for counterclockwise rotation.

**Table 23. LINEAR COMBINATIONS OF MODULUS FOR TRANSFORMATION OF MODULUS (GPa)**

	$U_1$	$U_2$	$U_3$	$U_4$	$U_5$
T300/5208	76.37	85.73	19.71	22.61	26.88
B(4)/5505	87.80	93.21	23.98	28.26	29.77
AS/3501	59.66	73.90	14.25	16.95	21.35
Scotchply /1002	20.47	15.4	3.33	5.53	7.47
Kevlar 49 /Epoxy	32.44	35.55	8.65	10.54	10.95

With the values listed in this table and the equations in Table 20 or 21, we can arrive at the same transformed modulus listed in Table 22 and shown in Fig. 35.

A typical calculation by the multiple-angle transformation is listed as follows:

From Table 21:  $Q'_{11} = U_1 + U_2 \cos 2\theta + U_3 \cos 4\theta$

From Table 23 for T300/5208:

$$Q'_{11} = 76.37 + 85.73 \cos 2\theta + 19.71 \cos 4\theta$$

when  $\theta = 45$  degrees,  $\cos 2\theta = 0$ ,  $\cos 4\theta = -1$

$$\begin{aligned} Q'_{11} &= 76.37 - 19.71 \\ &= 56.66 \end{aligned} \tag{107}$$

This result agrees with that shown in Table 22.

The calculation of transformed modulus using the invariant formulation as shown in Table 21 will be identical to the multiple angle because

$$\begin{aligned} R_1 &= +U_2 \\ R_2 &= +U_3 \end{aligned} \tag{108}$$

This identity is true only for the modulus transformation. As we shall see later, the transformed compliance calls for negative signs in Eq. 108. Then the multiple-angle formulation is not identical to the invariant formulation because of this sign change.

The following general remarks can be made about the transformed modulus:

- a. Mirror image exists between  $Q'_{11}$  and  $Q'_{22}$  and  $Q'_{16}$  and  $Q'_{26}$ . This can be shown by substituting  $\theta + 90$  into appropriate equations in Tables 20 or 21, and seen in Fig. 35.

$$\begin{aligned} Q'_{11}(\theta + 90) &= U_1 + U_2 \cos 2(\theta + 90) + U_3 \cos 4(\theta + 90) \\ &= U_1 - U_2 \cos 2\theta + U_3 \cos 4\theta \\ &= Q'_{22}(\theta) \end{aligned} \tag{109}$$

These two components can be superimposed by a displacement of 90 degrees along the  $\theta$ -axis. We can also show

$$Q'_{26}(\theta) = -Q'_{16}(\theta + 90) \tag{110}$$

These two components can be superimposed by a displacement and a rotation.

- b. The frequency and amplitude of  $Q'_{12}$  and  $Q'_{66}$  are the same; i. e.,  $4\theta$  and  $U_3$ , respectively. (See Table 20 and Fig. 36) The two transformed components are vertically displaced by the amount of  $U_5 - U_4$ .

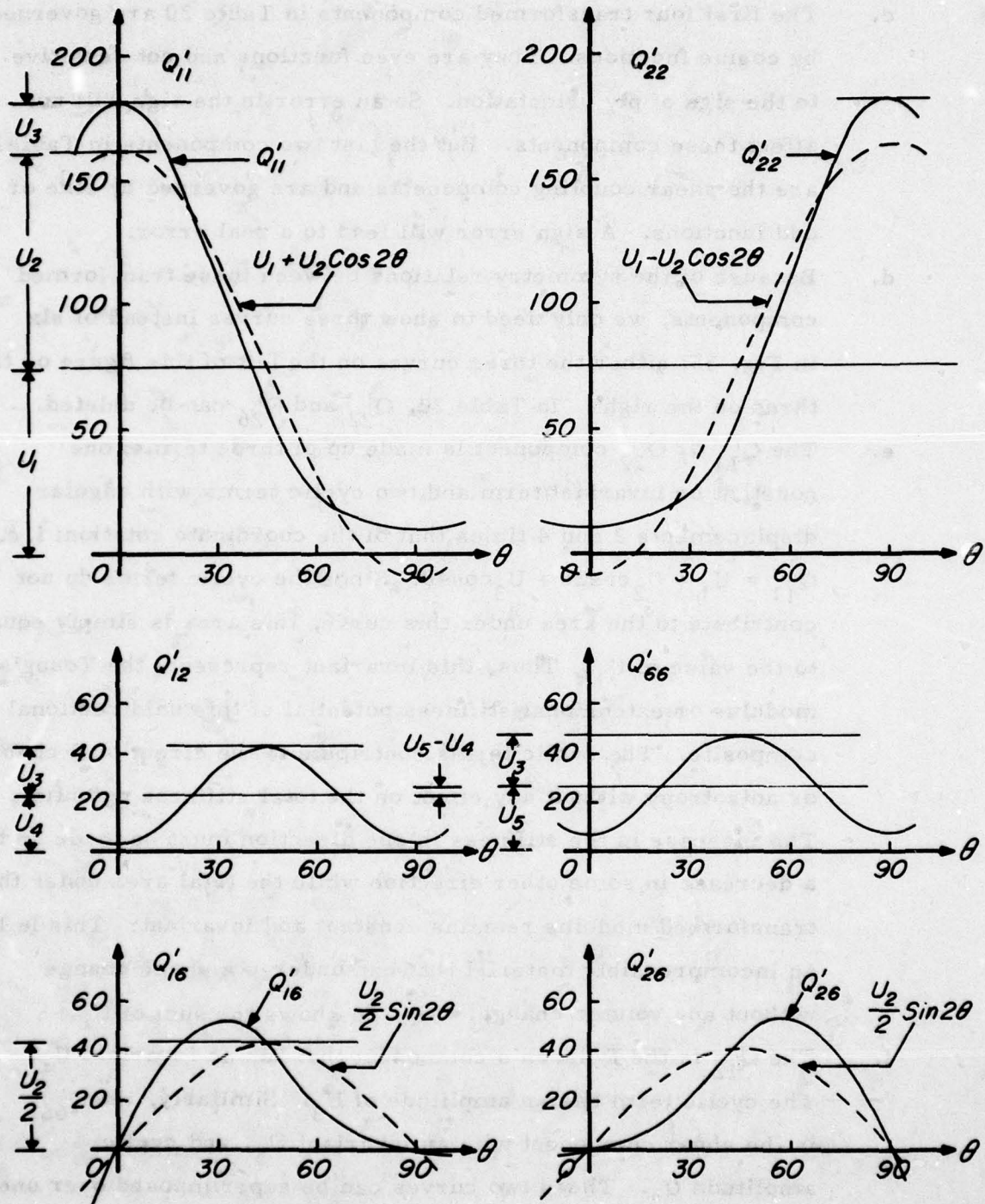

Fig. 36. Transformed modulus as functions of  $U_i$ . The relations in Table 20 are shown graphically. Each transformed component contains an invariant and/or cyclic terms.

- c. The first four transformed components in Table 20 are governed by cosine functions. They are even functions and not sensitive to the sign of ply orientation. So an error in the sign will not affect these components. But the last two components in Table 20 are the shear coupling components and are governed by sine or odd functions. A sign error will lead to a real error.
- d. Because of the symmetry relations between these transformed components, we only need to show three curves instead of six in Fig. 35; either the three curves on the left of this figure or the three on the right. In Table 22,  $Q'_{22}$  and  $Q'_{26}$  can be deleted.
- e. The  $Q'_{11}$  or  $Q'_{22}$  component is made up of three terms; one constant or invariant term and two cyclic terms with angular displacements 2 and 4 times that of the coordinate rotation; i. e.,  $Q'_{11} = U_1 + U_2 \cos 2\theta + U_3 \cos 4\theta$ . Since the cyclic terms do not contribute to the area under this curve, this area is simply equal to the value of  $U_1$ . Thus, this invariant represents the Young's modulus or extensional stiffness potential of this unidirectional composite. The cyclic terms contribute to the directional changes or anisotropy without any effect on the total stiffness potential. The increase in the stiffness in one direction must be made up by a decrease in some other direction while the total area under the transformed modulus remains constant and invariant. This is like an incompressible material that can undergo a shape change without any volume change. Fig. 36 shows the sum of  $U_i$ .
- f. The  $Q'_{12}$  is the Poisson's component that has an invariant  $U_4$ . The cyclic term has an amplitude of  $U_3$ . Similarly, the  $Q'_{66}$  is the shear component with an invariant  $U_5$ , and cyclic amplitude  $U_3$ . These two curves can be superimposed over one another by a vertical displacement:

$$U_5 - U_4 = Q'_{66} - Q'_{12} \quad (111)$$

The last step comes from Eq. 99. Any linear combinations of invariants are invariants. We, therefore, have a new but not independent invariants in Eq. 111.

- g. The shear coupling terms  $Q'_{16}$  and  $Q'_{26}$  have no invariant associated with the transformation. They are not independent in the sense that they are derivable from  $Q'_{11}$  and  $Q'_{22}$  by differentiation, respectively. From Table 20 and 21,

$$\frac{\partial Q'_{11}}{\partial \theta} = -2U_2 \sin 2\theta - 4U_3 \sin 4\theta = -4Q'_{16} \quad (112)$$

$$\frac{\partial Q'_{22}}{\partial \theta} = 2U_2 \sin 2\theta - 4U_3 \sin 4\theta = 4Q'_{26}$$

From Eq. 112(a)

$$\begin{aligned} Q'_{16} &= 0, \text{ when } \theta = 0 \text{ and } 90, \text{ or} \\ &\text{when } U_2 + 4U_3 \cos 2\theta = 0, \text{ or} \\ \cos 2\theta &= -U_2/4U_3 \end{aligned} \quad (113)$$

For T300/5208 from Table 22:

$$U_2/4U_3 = 85.73/4 \times 19.71 = 1.087 \quad (114)$$

There is, therefore, no solution for Eq. 114 or it means that this shear coupling does not go to zero other than at 0 and 90 degrees. The same holds true for  $Q'_{26}$ , except the sign in Eq. 114 is positive.

Because of these relations, the tangents, maximas and points of inflections between  $Q'_{11}$  and  $Q'_{16}$  can be shown

$$\frac{\partial^2 Q'_{11}}{\partial \theta^2} = -4U_2 \cos 2\theta - 16U_3 \cos 4\theta = 0 \quad (115)$$

Substituting  $\cos 4\theta = 2\cos^2 2\theta - 1$ , and

AD-A067 544

AIR FORCE MATERIALS LAB WRIGHT-PATTERSON AFB OHIO  
INTRODUCTION TO COMPOSITE MATERIALS. VOLUME I. DEFORMATION OF U--ETC(U)  
JAN 79 S W TSAI, H T HAHN  
AFML-TR-78-201-VOL-1

F/G 11/4

UNCLASSIFIED

NL

2 OF 3  
ADA  
067544

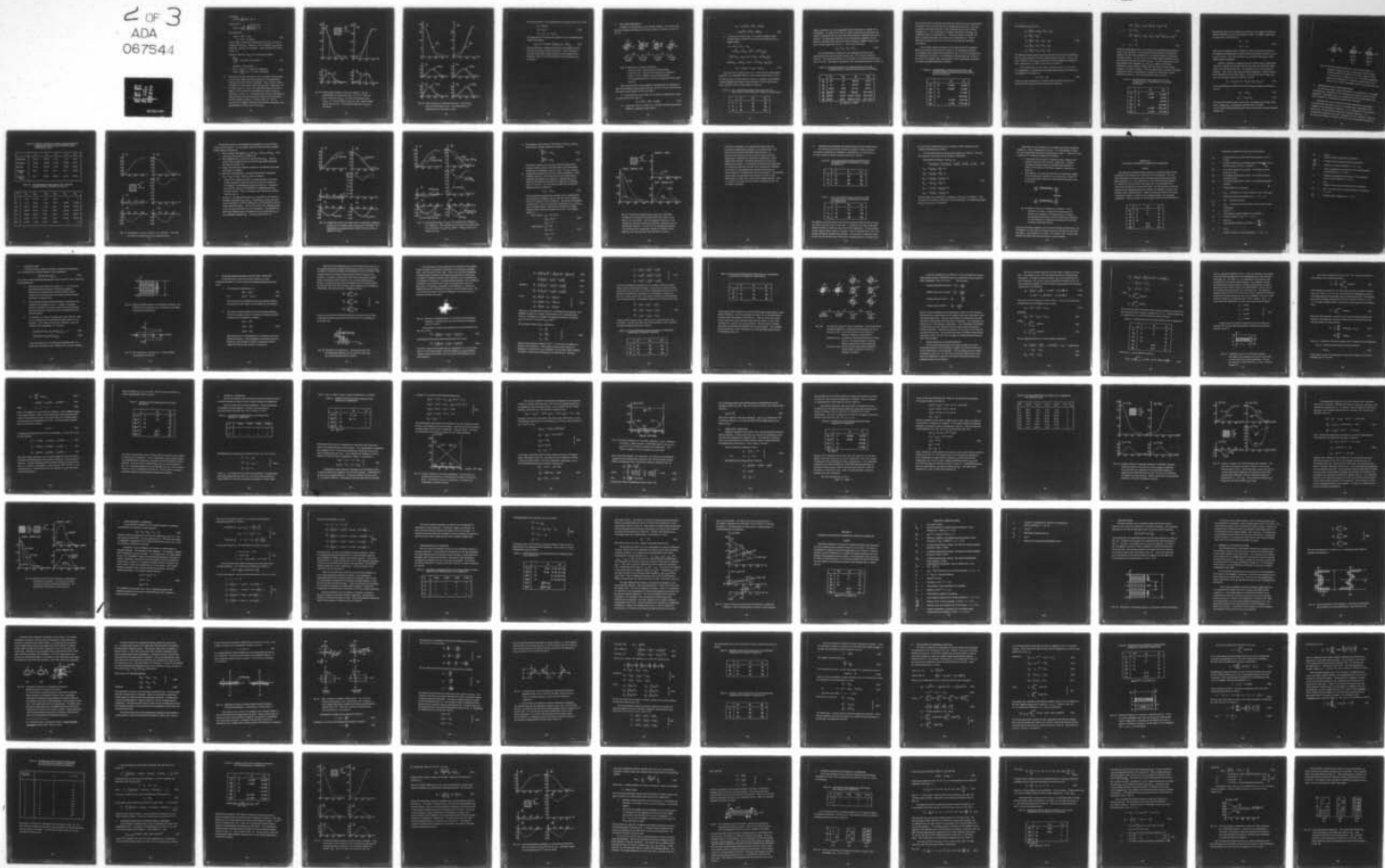

rearrange:

$$\cos^2 2\theta + \frac{U_2}{8U_3} \cos 2\theta - \frac{1}{2} = 0$$

solving for  $\theta$ :

$$\cos 2\theta = -\frac{U_2}{16U_3} \pm \sqrt{\left(\frac{U_2}{16U_3}\right)^2 + \frac{1}{2}}$$

For T300/5208,

$$\cos 2\theta = .485, -1.029 \quad (116)$$

$$\theta = 30.4, \text{ no solution}$$

At this angle, it is a point of inflection in the  $Q'_{11}$  curve and a maximum in the  $Q'_{16}$ . Similarly, at 59.6 degrees,  $Q'_{22}$  has the inflection, and  $Q'_{26}$ , the maximum. These relations are shown in Fig. 37.

Points of inflection of  $Q'_{16}$  can be found from letting

$$\frac{\partial^3 Q'_{11}}{\partial \theta^3} = 8U_2 \sin 2\theta + 64U_3 \sin 4\theta = 0 \quad (117)$$

$$8\sin 2\theta(U_2 + 16U_3 \cos 2\theta) = 0$$

$$\therefore \sin 2\theta = 0 \text{ or } \theta = 0, 90 \text{ for all components} \quad (118)$$

$$\cos 2\theta = -\frac{U_2}{16U_3} \text{ or } \theta = 52.88 \text{ for T300/5208}$$

- h. The power functions formulation for the modulus transformation can be used to demonstrate the dominance of the longitudinal properties of unidirectional composites. Since the first column of Table 19 is many times higher than the other components; i. e., 181 GPa versus 10, 3 and 7 for T300/5208 based on the data in Table 9, we can show the contribution of the first column or that of  $Q'_{11}$ , in Fig. 38. The dashed lines are those transformed modulus based on the first column of Table 19; the solid lines are the complete solutions, as those in Fig. 35. We can see that for our highly anisotropic unidirectional composite, this approximation is fairly close to the exact.

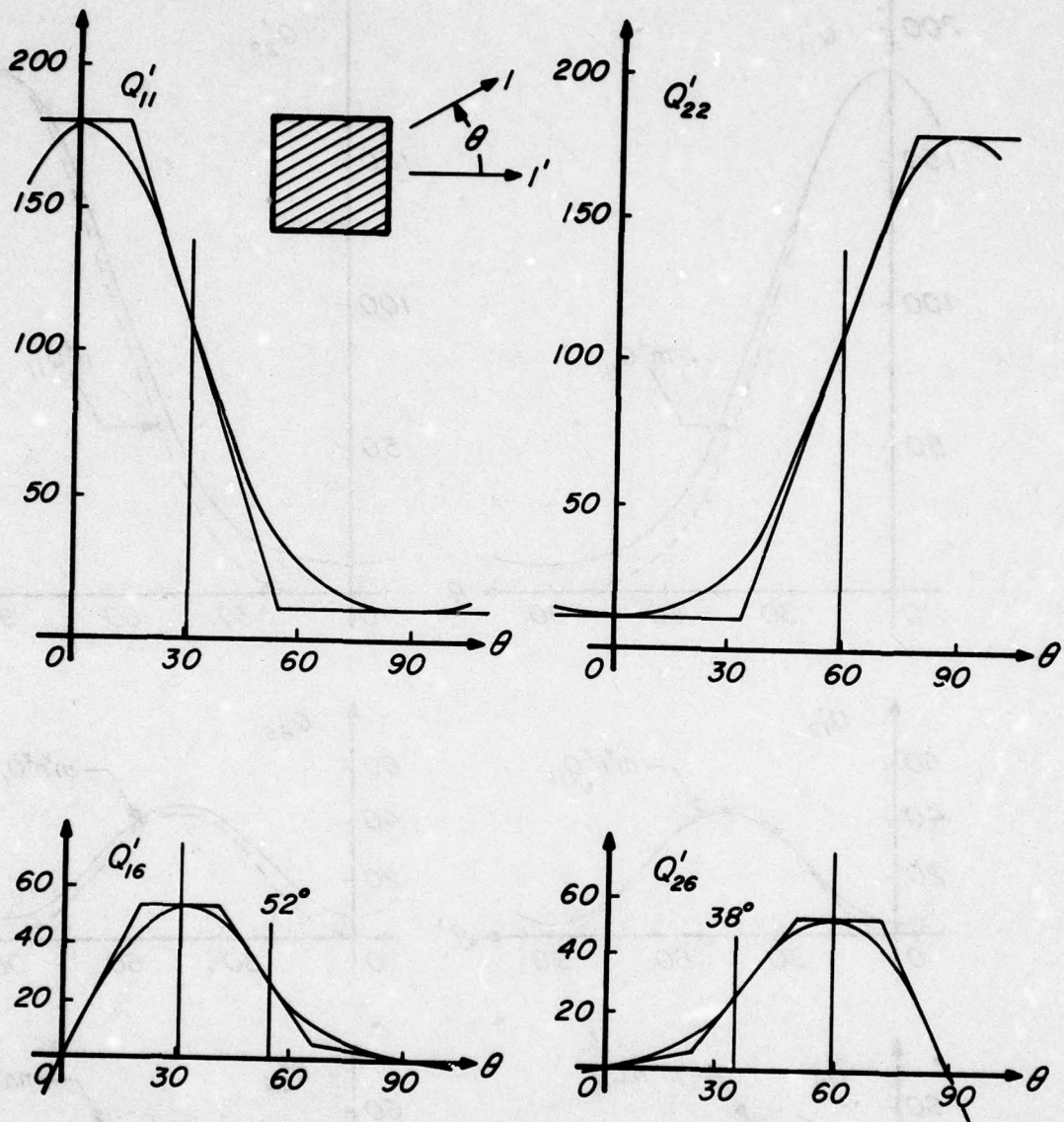

Fig. 37. Relationships between transformed modulus. Special relationships are expressed in Eq. 112 to 116. Note the point of inflection in  $Q'_{11}$  is the point of maximum value in  $Q'_{16}$ . At 0 and 90 degrees,  $Q'_{16}$  are zero, and the slopes of  $Q'_{11}$  are also zero. The points of inflection for  $Q'_{16}$  are also shown.

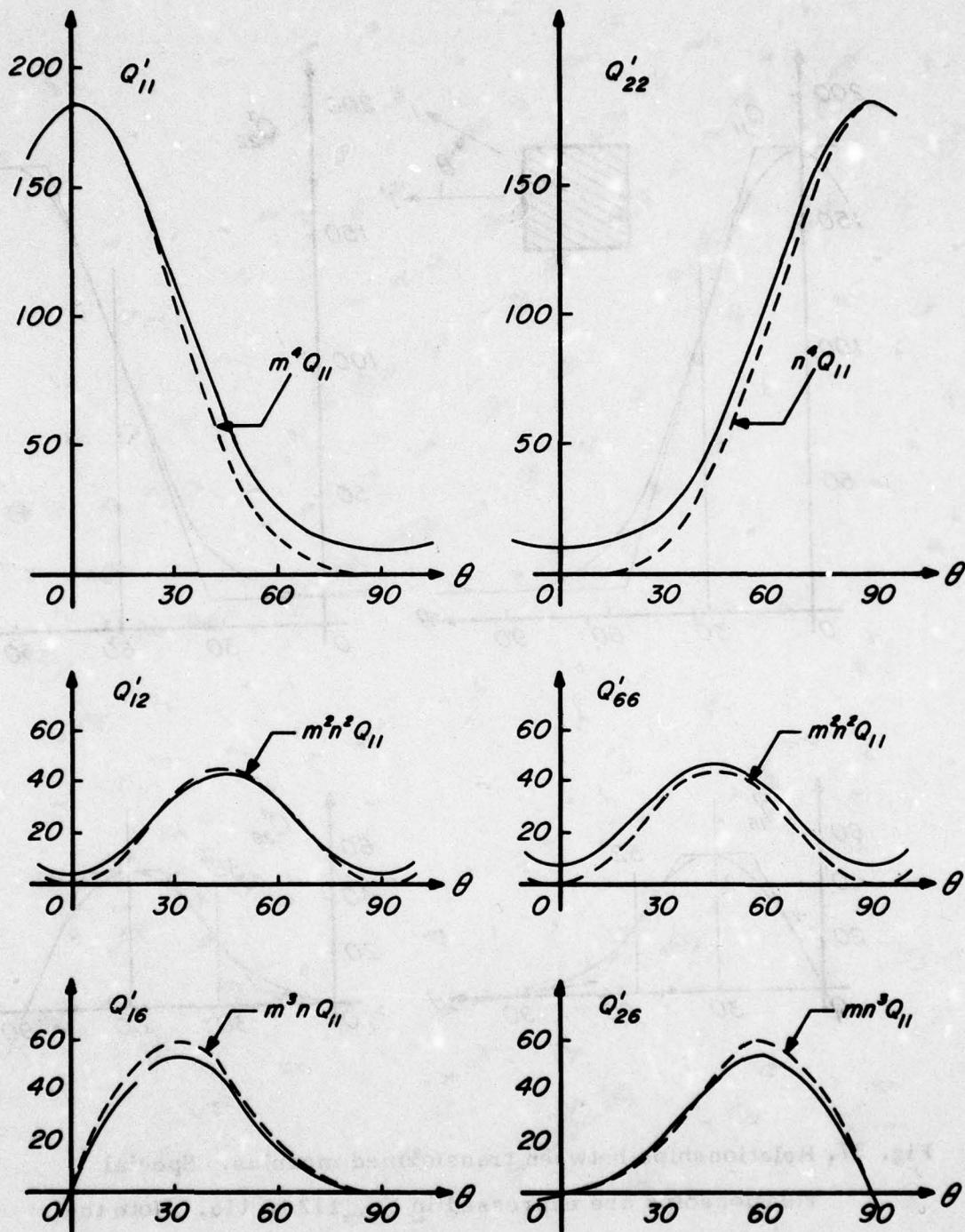

Fig. 38. Approximation of transformed modulus. Only the  $Q_{11}$  term for T300/5208 is used. The dashed lines are approximate; the solid lines, exact.

By the same token, we can approximate the values of  $U_s$  in Eq. 99 as:

$$\begin{aligned}U_1 &= 3Q_{11}/8 \\U_2 &= Q_{11}/2 \\U_3 &= U_4 = U_5 = Q_{11}/8\end{aligned}\tag{119}$$

The approximate transformation equations can be simplified from Table 20 as follows:

$$Q'_{11} = (3 + 4\cos 2\theta + \cos 4\theta)Q_{11}/8 = m^4 Q_{11}\tag{120}$$

This and the other components of transformed modulus will be the same as the first column of Table 19. Thus, both power functions and multiple-angle functions for the modulus transformation reduce to the same limiting case when only the  $Q_{11}$  is present.

### 3. OFF-AXIS COMPLIANCE

Analogous to the approach for the off-axis modulus, we can derive the off-axis compliance following the sequence of Fig. 39, which is a repeat of Fig. 16.

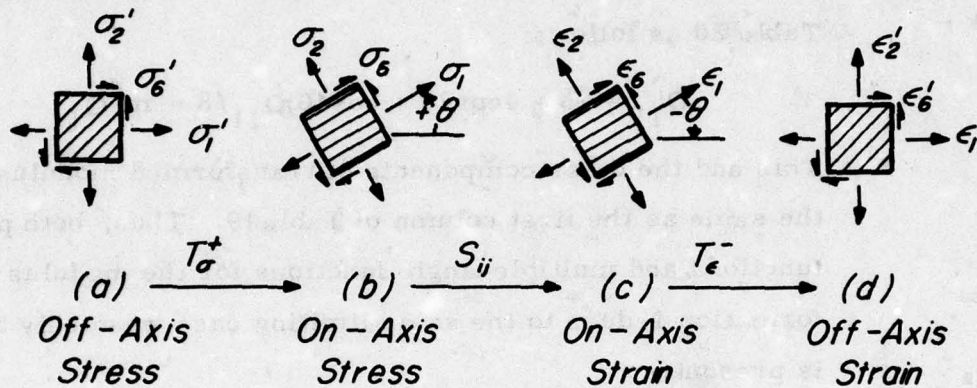

Fig. 39. Derivation of off-axis compliance.

From (a) to (b): Positive stress transformation.

From (b) to (c): Stress-strain relations in compliance.

From (c) to (d): Negative strain transformation.

We can go directly from (a) to (d) by merging the three steps into one.

Since the derivation of the compliance transformation is analogous to that of the modulus transformation from Eq. 88 to 94, we will write only the first line of each equation for this derivation.

- To go from (a) to (b) in Fig. 39, we know the equations for stress transformation from Table 10:

$$\sigma_1 = m^2 \sigma_1' + n^2 \sigma_2' + 2mn \sigma_6' \quad (121)$$

- To go from (b) to (c) in Fig. 39 we need the on-axis stress-strain relation in compliance from Table 5.

$$\begin{aligned} \epsilon_1 = & S_{11}(m^2\sigma_1' + n^2\sigma_2' + 2mn\sigma_6') \\ & + S_{12}(n^2\sigma_1' + m^2\sigma_2' - 2mn\sigma_6') \end{aligned} \quad (122)$$

- To go from (c) to (d) in Fig. 39 we need the negative strain transformation in Table 14 where the sine functions now have negative signs.

$$\begin{aligned} \epsilon_1' = & m^2\epsilon_1 + n^2\epsilon_2 - mn\sigma_6 \\ = & \left[ m^4S_{11} + n^4S_{22} + 2m^2n^2 + m^2n^2S_{66} \right] \sigma_1' \\ & + \left[ m^2n^2(S_{11} + S_{22}) + (m^4 + n^4)S_{12} - m^2n^2S_{66} \right] \sigma_2' \\ & + \left[ 2m^3nS_{11} - 2mn^3S_{22} + (mn^3 - mn^3)(2S_{12} + S_{66}) \right] \sigma_6' \\ \epsilon_1' = & S'_{11}\sigma_1' + S'_{12}\sigma_2' + S'_{16}\sigma_6' \end{aligned} \quad (123)$$

Note that shear coupling terms appear in this off-axis unidirectional composite, in an analogous fashion as the off-axis modulus Eq. 92 to 94.

The off-axis stress-strain relation in terms of compliance is presented in a matrix multiplication table in Table 24 similar to the off-axis stress-strain relation in terms of the modulus in Table 18.

Table 24. OFF-AXIS STRESS-STRAIN RELATION FOR UNIDIRECTIONAL COMPOSITES IN TERMS OF COMPLIANCE

	$\sigma_1'$	$\sigma_2'$	$\sigma_6'$
$\epsilon_1'$	$S'_{11}$	$S'_{12}$	$S'_{16}$
$\epsilon_2'$	$S'_{21}$	$S'_{22}$	$S'_{26}$
$\epsilon_6'$	$S'_{61}$	$S'_{62}$	$S'_{66}$

Again, the primes can all be eliminated without affecting the validity of the relationship. As stated previously, the choice of primed and unprimed coordinates is arbitrary and can vary from unidirectional to multidirectional components. The symmetry relations for the transformed compliance can be shown by including interaction terms  $\sigma_1\sigma_6$  and  $\sigma_2\sigma_6$  in addition to  $\sigma_1\sigma_2$  in the stored energy expression in Eq. 17. We can then show that

$$S'_{16} = S'_{61}, \quad S'_{26} = S'_{62} \quad (124)$$

The transformation equations for the compliance are taken from matching like terms in the last two steps of Eq. 123 and will be shown in Table 25. The missing equations can be derived in an analogous fashion from Eq. 121 to 123. This table is analogous to the transformed modulus in Table 19.

Table 25. TRANSFORMATION OF COMPLIANCE OF ON-AXIS UNIDIRECTIONAL COMPOSITES IN POWER FUNCTIONS

	$S_{11}$	$S_{22}$	$S_{12}$	$S_{66}$
$S'_{11}$	$m^4$	$n^4$	$2m^2n^2$	$m^2n^2$
$S'_{22}$	$n^4$	$m^4$	$2m^2n^2$	$m^2n^2$
$S'_{12}$	$m^2n^2$	$m^2n^2$	$m^4+n^4$	$-m^2n^2$
$S'_{66}$	$4m^2n^2$	$4m^2n^2$	$-8m^2n^2$	$(m^2-n^2)^2$
$S'_{16}$	$2m^3n$	$-2mn^3$	$2(mn^3-m^3n)$	$mn^3-m^3n$
$S'_{26}$	$2mn^3$	$-2m^3n$	$2(m^3n-mn^3)$	$m^3n-mn^3$

$$m = \cos \theta, \quad n = \sin \theta$$

Note that the difference between this table and Table 19 for the transformation of modulus can be traced to the use of engineering shear strain. For each component with single subscript 6, the coefficients on each row shall be multiplied by 2. For components with double subscript 6, such  $S'_{66}$ , the coefficients shall be multiplied by 4. In the last column of Table 25, the effect of double subscript 6 is to divide each coefficient by 4. All the differences between Tables 25 and 29 can be accounted for with these corrections.

The multiple-angle formulation of the transformation of compliance follows precisely the same pattern as that for the transformed modulus. The multiple-angle trigonometric identities in Eq. 95 can be substituted into the coefficients in Table 25. By following the process from Eq. 96-98 we can derive the multiple-angle representation of the transformed compliance in a matrix multiplication table as follows:

Table 26. TRANSFORMED COMPLIANCE FOR ON-AXIS UNIDIRECTIONAL COMPOSITES IN MULTIPLE-ANGLE FUNCTIONS

	$U_1$	$U_2$	$U_3$
$S'_{11}$	$U_1$	$\cos 2\theta$	$\cos 4\theta$
$S'_{22}$	$U_1$	$-\cos 2\theta$	$\cos 4\theta$
$S'_{12}$	$U_4$		$-\cos 4\theta$
$S'_{66}$	$U_5$		$-4\cos 4\theta$
$S'_{16}$		$\sin 2\theta$	$2\sin 4\theta$
$S'_{26}$		$\sin 2\theta$	$-2\sin 4\theta$

The definitions of the  $U_i$  are:

$$\begin{aligned}U_1 &= \frac{1}{8}(3S_{11} + 3S_{22} + 2S_{12} + S_{66}) \\U_2 &= \frac{1}{2}(S_{11} - S_{22}) \\U_3 &= \frac{1}{8}(S_{11} + S_{22} - 2S_{12} - S_{66}) \\U_4 &= \frac{1}{8}(S_{11} + S_{22} + 6S_{12} - S_{66}) \\U_5 &= \frac{1}{2}(S_{11} + S_{22} - 2S_{12} + S_{66})\end{aligned}\tag{125}$$

The difference between the  $U_i$  of this equation and those for the modulus in Eq. 99 can be traced to the use of engineering shear strain. The  $U_5$ , the shear invariant, and the  $S_{66}$  component must be multiplied and divided by four, respectively, in order to match Eq. 125 with 99.

Of the three linear or first-order invariants in Eq. 125, only two are independent. The following relationship shows that the third invariant is dependent on the other two.

$$U_5 = 2(U_1 - U_4)\tag{126}$$

There are also two quadratic or second-order invariants which can be derived from the second and third columns in Table 26.

$$R_1^2 = \frac{1}{4} (S'_{11} - S'_{22})^2 + \frac{1}{4} (S'_{16} + S'_{26})^2 = U_2^2$$

or  $R_1 = \pm U_2$  (127)

$$R_2^2 = \frac{1}{64} (S'_{11} + S'_{22} - 2S'_{12} - S'_{66})^2 + \frac{1}{16} (S'_{16} - S'_{26})^2$$

$$= U_3^2$$

or  $R_2 = \pm U_3$  (128)

From the relationship above, we can derive the transformation equations in terms of the invariants. As mentioned in the discussion of transformed modulus, the invariant formulation has one drawback which is associated with phase angles. For this reason, the multiple-angle formulation is preferred because the signs are self-contained. For the compliance of an on-axis unidirectional composite,  $U_2$  and  $U_3$  are negative if the longitudinal (the 1-axis) stiffness is higher than the transverse (the 2-axis) stiffness. See data in Table 28. But for completeness of all three alternative formulations of the transformation of compliance, that of the invariant functions is listed in a matrix multiplication table as follows:

Table 27. TRANSFORMED COMPLIANCE OF ON-AXIS UNIDIRECTIONAL COMPOSITES IN INVARIANT FUNCTIONS

	<i>I</i>	<i>R</i> <sub>1</sub>	<i>R</i> <sub>2</sub>
<i>S</i> ' <sub>11</sub>	<i>U</i> <sub>1</sub>	-cos2θ	-cos4θ
<i>S</i> ' <sub>22</sub>	<i>U</i> <sub>1</sub>	cos2θ	-cos4θ
<i>S</i> ' <sub>12</sub>	<i>U</i> <sub>4</sub>		cos4θ
<i>S</i> ' <sub>66</sub>	<i>U</i> <sub>5</sub>		4cos4θ
<i>S</i> ' <sub>16</sub>		-sin2θ	-2sin4θ
<i>S</i> ' <sub>26</sub>		-sin2θ	2sin4θ

Note that the signs of the trigonometric functions are changed from those in Table 26 because  $U_2$  and  $U_3$  have negative values. So negative signs must be used in Eq. 127 and 128, or

$$\begin{aligned} R_1 &= -U_2 \\ R_2 &= -U_3 \end{aligned} \tag{129}$$

This choice of negative values is different from the invariant functions of the modulus transformation in Table 21 where the positive values of  $U_2$  and  $U_3$  were picked. This was so because  $Q_{11}$  is greater than  $Q_{22}$  for most unidirectional composites.

Finally, compliance components also provide the link to engineering constants. Modulus can provide this link only when the material is orthotropic, or in its symmetry axes. But compliance does not have this restriction. This can be easily demonstrated by applying a uniaxial stress in the 1'-direction of an off-axis coupon. Then from the stress-strain relation of an off-axis material in Table 24, we have

$$\epsilon'_1 = S'_{11}\sigma'_1, \epsilon'_2 = S'_{21}\sigma'_1, \epsilon'_6 = S'_{61}\sigma'_1 \tag{130}$$

We can immediately establish the off-axis Young's modulus and Poisson's ratio as

$$E'_1 = 1/S'_{11} \tag{131}$$

$$\nu'_{12} = -S'_{21}/S'_{11} \tag{132}$$

The sign of the induced shear strain in Eq. 130 depends on the sign of the shear coupling  $S'_{16}$ , assuming the applied stress is tensile.

Fig. 40 shows the two possible shear strains induced by an off-axis uniaxial tensile test.

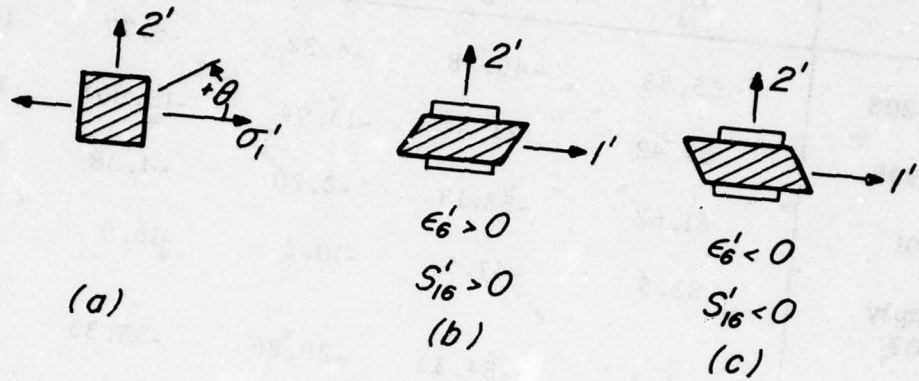

Fig. 40. Off-axis uniaxial tensile test. This test can induce, in addition to normal strains, positive shear strain if shear coupling coefficient is positive as in (b); or negative shear, if the coefficient is negative as in (c). For most composites, positive ply orientation in (a) induces negative shear in (c) because  $U_2$  in Table 28 is negative and so is  $S'_{16}$  (See Fig. 41).

#### 4. EXAMPLES OF OFF-AXIS COMPLIANCE

We will show in this section the transformed compliance for T300/5208. The orthotropic components of the compliance are listed in Table 8 for this composite. When these values are substituted into the transformation equations in Table 25, we will get the transformed compliance.

Alternatively, we can arrive at the same transformed components if we use the following values of  $U_i$  in the multiple angle formulation of the compliance transformation in Table 28.  $U_i$  are computed from the relations given in Eq. 125 and listed in Table 28 for typical composites. The transformed compliance can then be computed from the relations in Table 26. The numerical results are listed in Table 29, and curves plotted in Fig. 41.

Table 28. TYPICAL VALUES OF LINEAR COMBINATIONS OF COMPLIANCE FOR ON-AXIS UNIDIRECTIONAL COMPOSITES (TPa)<sup>-1</sup>

	$U_1$	$U_2$	$U_3$	$U_4$	$U_5$
T300/5208	55.53	-45.78	-4.22	-5.77	122.6
B(4)/5505	43.42	-24.55	-13.94	-15.06	117.0
AS/3501	61.62	-52.18	-2.20	-4.38	132.0
Scotchply /1002	83.5	-47.5	-10.2	-16.9	200.8
Kevlar 49 /Epoxy	126.4	-84.33	-28.86	-33.33	319.4

Table 29. TRANSFORMED COMPLIANCE FOR T300/5208 UNIDIRECTIONAL COMPOSITES (TPa)<sup>-1</sup>

$\theta$	$S'_{11}$	$S'_{22}$	$S'_{12}$	$S'_{66}$	$S'_{16}$	$S'_{26}$
0	5.52	97.09	-1.55	139.4	0	0
15	13.77	93.06	-3.66	131.0	-30.20	-15.58
30	34.75	80.53	-7.88	114.1	-46.96	-32.34
45	59.75	59.75	-9.99	105.7	-45.78	-45.78
60	80.53	34.75	-7.88	114.1	-32.34	-46.96
75	93.06	13.77	-3.66	131.0	-15.58	-30.20
90	97.09	5.52	-1.54	139.4	0	0

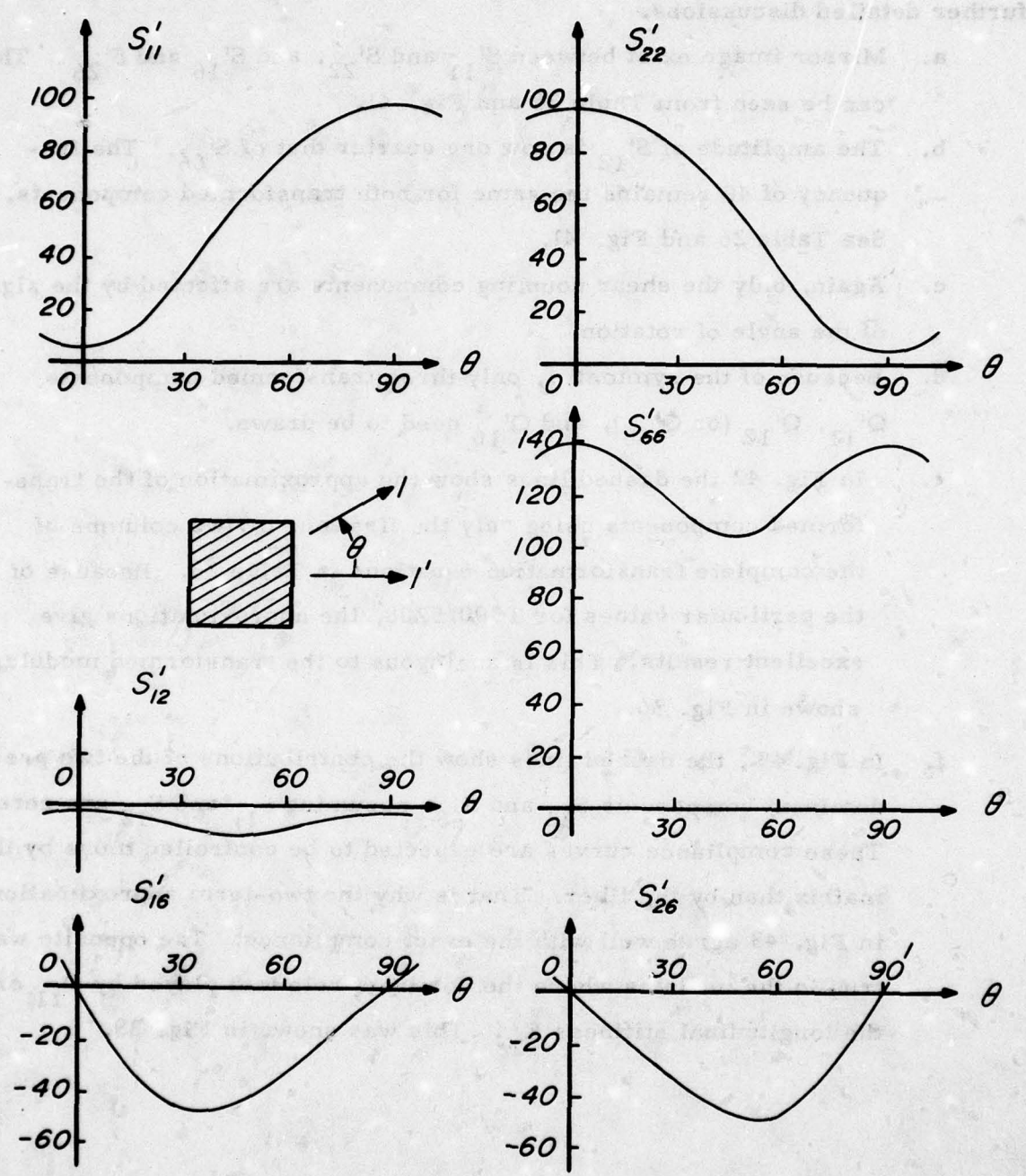

Fig. 41. Transformed, off-axis compliance of T300/5208. The angle of rotation is positive when it is counterclockwise.

The general remarks on the transformed compliance are very similar to those on the modulus. We will simply repeat the relevant features without further detailed discussions.

- a. Mirror image exist between  $S'_{11}$  and  $S'_{22}$ , and  $S'_{16}$  and  $S'_{26}$ . This can be seen from Table 26 and Fig. 41.
- b. The amplitude of  $S'_{12}$  is now one quarter that of  $S'_{66}$ . The frequency of 40 remains the same for both transformed components. See Table 26 and Fig. 41.
- c. Again, only the shear coupling components are affected by the sign of the angle of rotation.
- d. Because of the symmetry, only three transformed components  $Q'_{11}$ ,  $Q'_{12}$  (or  $Q'_{66}$ ), and  $Q'_{16}$  need to be drawn.
- e. In Fig. 42 the dashed lines show the approximation of the transformed components using only the first one or two columns of the complete transformation equations in Table 26. Because of the particular values for T300/5208, the approximations give excellent results. This is analogous to the transformed modulus shown in Fig. 36.
- f. In Fig. 43, the dashed lines show the contributions of the two predominant components  $S_{22}$  and  $S_{66}$ , assuming  $S_{11}$  and  $S_{12}$  are zero. These compliance curves are expected to be controlled more by the matrix than by the fiber. That is why the two-term approximations in Fig. 43 agree well with the exact compliance. The opposite was true in the modulus where the dominant role was played by  $Q_{11}$  or the longitudinal stiffness  $E_L$ . This was shown in Fig. 38.

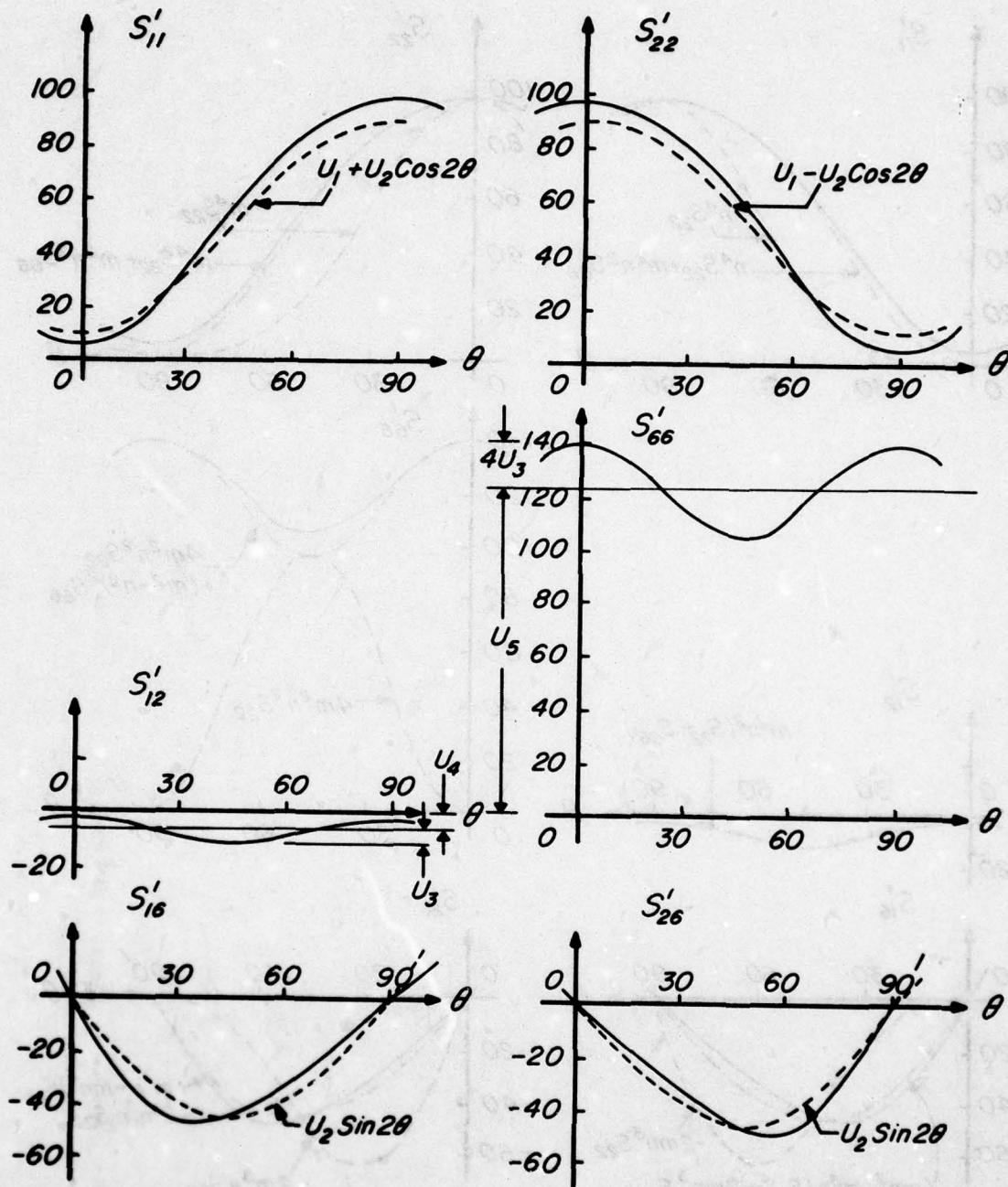

Fig. 42, Comparison of exact and approximate transformed compliance in terms of the multiple-angle functions for T300/5208. The dashed lines are approximations without the last column in Table 26 or  $U_3=0$ .

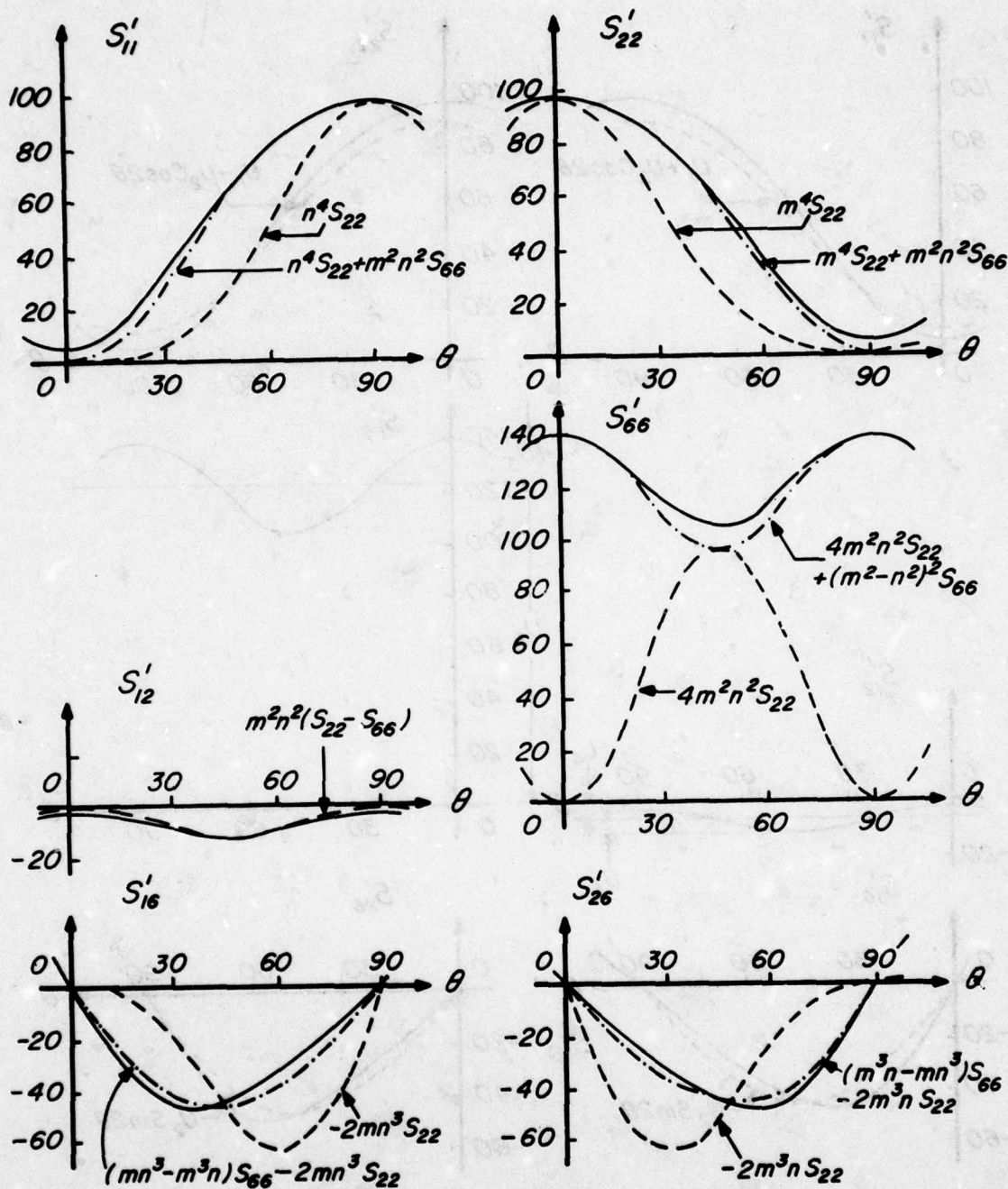

Fig. 43. Contributions of  $S_{22}$  and  $S_{66}$  to the transformed compliance for T300/5208. The solid lines are the exact; the dashed lines, the contribution of  $S_{22}$  and  $S_{66}$  terms. The  $S_{11}$  and  $S_{12}$  are taken to be zero.

- g. Relationships exist between the derivatives of the  $S'_{11}$  and  $S'_{22}$  and the shear coupling components as follows:

$$\frac{\delta S'_{11}}{\delta \theta} = -2S'_{16} \quad (133)$$

$$\frac{\delta S'_{22}}{\delta \theta} = 2S'_{26} \quad (134)$$

From these relations, we can easily obtain the angles where maxima, minima, points of inflection exist in the transformed components of compliance, similar to Fig. 37 for the modulus.

- h. Engineering constants will also vary with ply orientation. These constants, however, are not governed by any transformation equations like modulus and compliance, although they can be related to transformed components of compliance as indicated in Eq. 131 and 132. We can similarly define the transformed engineering shear modulus as:

$$G'_{12} = 1/S'_{66} \quad (135)$$

These transformed engineering constants can be computed from the transformed compliance data in Table 29, and are plotted in Fig. 44 as functions of ply orientations. Also shown in this figure, as dashed lines, are the transformed components of  $Q'_{11}$  and  $Q'_{66}$ . Note that these modulus components have identical or nearly identical values when ply orientation is 0 or 90. For example; when  $\theta = 0$

From Table 9,  $Q_{11} = 181.8$  GPa

$$Q_{22} = 10.34 \quad " \quad (136)$$

$$Q_{66} = 7.17 \quad "$$

From Table 7,  $E_L = 181 \quad "$

$$E_T = 10.3 \quad " \quad (137)$$

$$G_{LT} = 7.17 \quad "$$

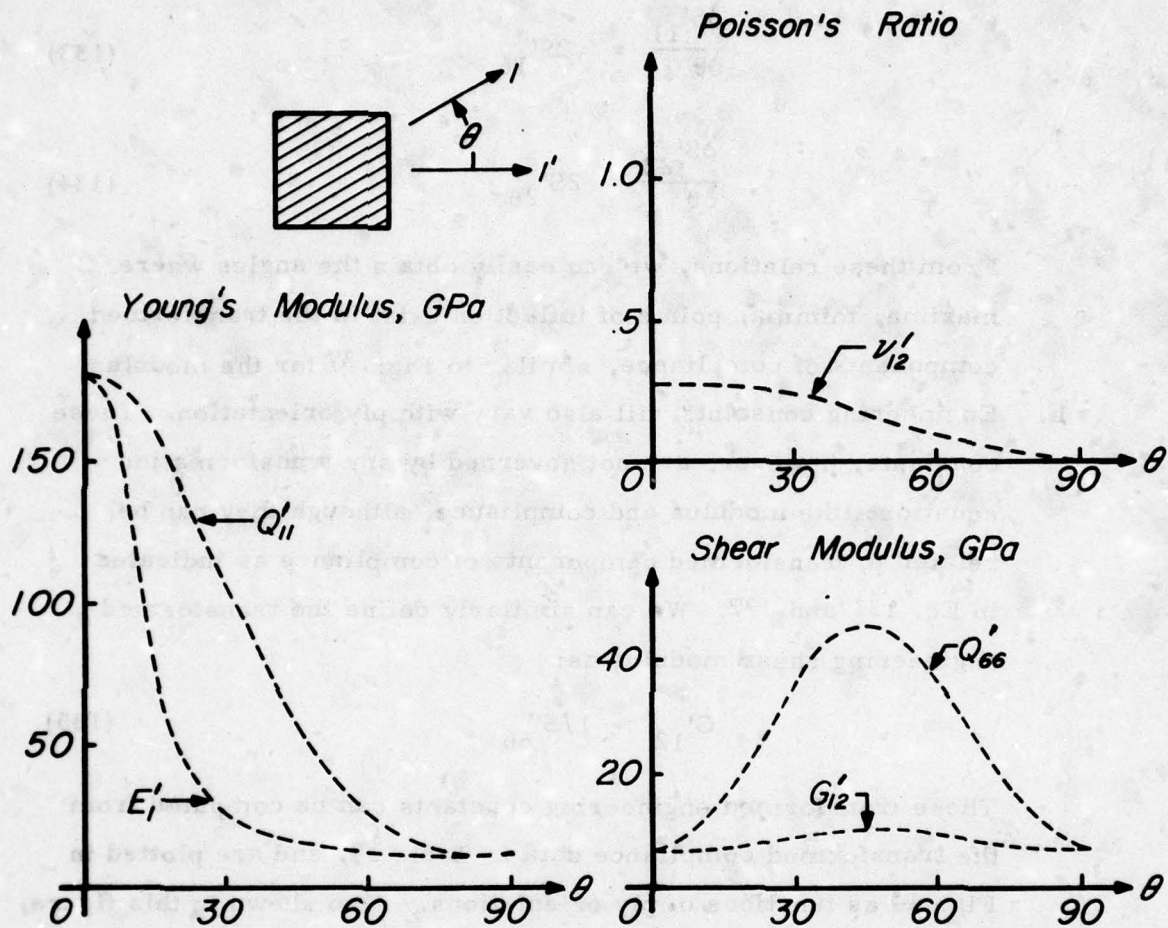

Fig. 44. Transformed engineering constants for T300/5208.

Transformed components of modulus taken from Table 22 and Fig. 35 are also shown. Note the significant difference of the transformed quantities between the modulus components and the engineering constants. In order to avoid making big mistakes, we recommend that engineering constants be limited to those applied to the symmetry axis only, like those in Table 7.

In off-axis orientations, the transformed modulus and the transformed engineering constants are no longer close. The former can be several folds higher than the latter. In laminated and built-up structures the most direct material properties for stiffness are the modulus components, not the engineering constants. The basic issue lies in the fact that engineering constants are essentially one-dimensional properties. It is with great difficulty and with much unnecessary complexity if we insist on using engineering constants to describe the elastic behavior of laminated and built-up structures. Unfortunately, many design and experimental procedures are built on one-dimensional concepts where engineering constants abound. This is a carryover by those who have gotten accustomed to the use of ordinary materials.

$\theta$	$E_x$	$E_y$	$\nu_{xy}$
0°	100	100	0.3
15°	105	105	0.3
30°	110	110	0.3
45°	115	115	0.3
60°	120	120	0.3
75°	125	125	0.3
90°	130	130	0.3

The difference between the stress-strain relations... that the role of stress and strain are the reverse of each other. In Table 30, the stress is the independent variable in Table 31, the stress is the independent. We inverted the on-axis stress-strain relations in Section 1 and we went from Eq. 3 to 11 by simply solving the simultaneous equations. We need only to repeat the same process for the off-axis case, where the engineering terms are no longer zero.

5. INVERSE RELATIONSHIP BETWEEN MODULUS AND COMPLIANCE

The off-axis stress-strain relations as listed in Tables 18 and 24, are based on modulus and compliance, respectively, are repeated here as Tables 30 and 31 except all primes have been removed.

Table 30. OFF-AXIS STRESS-STRAIN RELATION FOR UNIDIRECTIONAL COMPOSITES IN TERMS OF MODULUS

	$\epsilon_1$	$\epsilon_2$	$\epsilon_6$
$\sigma_1$	$Q_{11}$	$Q_{12}$	$Q_{16}$
$\sigma_2$	$Q_{21}$	$Q_{22}$	$Q_{26}$
$\sigma_6$	$Q_{61}$	$Q_{62}$	$Q_{66}$

Table 31. OFF-AXIS STRESS-STRAIN RELATION FOR UNIDIRECTIONAL COMPOSITES IN TERMS OF COMPLIANCE

	$\sigma_1$	$\sigma_2$	$\sigma_6$
$\epsilon_1$	$S_{11}$	$S_{12}$	$S_{16}$
$\epsilon_2$	$S_{21}$	$S_{22}$	$S_{26}$
$\epsilon_6$	$S_{61}$	$S_{62}$	$S_{66}$

The difference between these stress-strain relations is that the role of stress and strain are the inverse of each other. In Table 30, the strain is the independent variable; in Table 31, the stress is the independent. We inverted the on-axis stress-strain relations in Section 1 when we went from Eq. 8 to 11 by simply solving the simultaneous equations. We need only to repeat the same process for the off-axis case, where shear coupling terms are no longer zero.

We can proceed with the inversion or solution of these equations by the method of determinant as follows:

We will assume that we are given the equations in Table 30. We will first obtain the determinant of the modulus components:

$$\begin{aligned} \text{Determinant of Modulus} &= \det Q_{ij} = \Delta \\ &= Q_{11}Q_{22}Q_{66} + 2Q_{12}Q_{26}Q_{61} - Q_{22}Q_{16}^2 - Q_{66}Q_{12}^2 - Q_{11}Q_{62}^2 \end{aligned} \quad (138)$$

$$S_{11} = (Q_{22}Q_{66} - Q_{26}^2) / \Delta$$

$$S_{22} = (Q_{11}Q_{66} - Q_{16}^2) / \Delta$$

$$S_{12} = (Q_{16}Q_{26} - Q_{12}Q_{66}) / \Delta$$

$$S_{66} = (Q_{11}Q_{22} - Q_{12}^2) / \Delta$$

$$S_{16} = (Q_{12}Q_{26} - Q_{22}Q_{16}) / \Delta$$

$$S_{26} = (Q_{12}Q_{16} - Q_{11}Q_{26}) / \Delta$$

(139)

We have gotten the components of compliance from those of modulus. If we are given the compliance and want to know the modulus, we simply interchange the  $Q_{ij}$  for  $S_{ij}$  in Eq. 138 and 139.

Thus there are two ways that we can compute the off-axis modulus or compliance. This is diagrammed in Fig. 45. Our starting point consists of a set of engineering constants as those listed in Table 7. There are 2 ways of getting the transformed compliance and modulus:

- a. From engineering constants, compute on-axis compliance and modulus, shown in Tables 8 and 9, respectively. Compute transformed modulus using its transformation equations in Table 20 and compute transformed compliance using those in Table 26.
- b. Alternatively, we can go directly from the transformed modulus to the transformed compliance by inversion in Eq. 138 and 139 or the transformed compliance to the transformed modulus also by inversion.

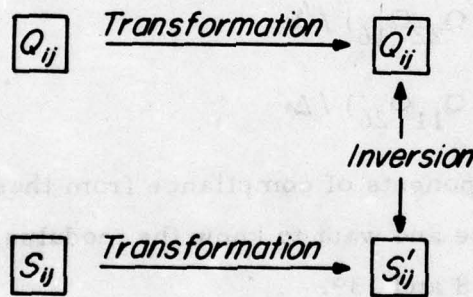

Fig. 45. Relation of off-axis compliance and modulus. Can be obtained in two ways: (a) separate transformations of modulus and compliance; (b) transformation of modulus then followed by inversion to obtain transformed compliance; or transformation of compliance then followed by inversion to obtain transformed modulus.

From the operational standpoint, the inversion following transformation, the 2nd method, is a little easier to perform than the 1st method, the two transformations. But the difference is small. We should be well versed in both methods and choose the one that is best for a given situation.

SECTION IV  
IN-PLANE STIFFNESS OF SYMMETRIC LAMINATES

SCOPE

The stiffness of multidirectional laminates consisting of plies and ply assemblies with arbitrary ply orientations will be described. The composite laminates are limited to those stacking sequences which have mid-plane symmetry; i. e., ply orientations in the lower half of the laminates are exactly the same as those in the upper half. Such laminates will behave like a homogeneous anisotropic plate. We will see that the effective modulus of the composite laminate is simply the arithmetic average of the modulus of the constituent plies. Simple formulas and charts can be made so laminate modulus, in terms of the constituent plies, can be quickly established. The key relation for the in-plane modulus of any laminate is:

	$h$	$U_2$	$U_3$
$A_{11}$	$U_1$	$V_1$	$V_2$
$A_{22}$	$U_1$	$-V_1$	$V_2$
$A_{12}$	$U_4$		$-V_2$
$A_{33}$	$U_3$		$-V_2$
$A_{16}$		$V_3/2$	$V_4$
$A_{26}$		$V_3/2$	$-V_4$

## PRINCIPAL NOMENCLATURE AND DEFINITIONS

- $A_{ij}$  = In-plane modulus of multidirectional laminates, in  $Nm^{-1}$ , or Pam.
- $a_{ij}$  = In-plane compliance of multidirectional laminates; it is the inverse of  $A_{ij}$ , in  $N^{-1}m$ , or  $(Pam)^{-1}$ .
- $E_1^o$  = An in-plane engineering constant: the Young's modulus along the 1-axis.
- $E_2^o$  = An in-plane engineering constant: the Young's modulus along the 2-axis.
- $G_{12}^o$  = An in-plane engineering constant: the longitudinal shear modulus.
- $h$  = Total thickness of a laminate.
- $h_i$  =  $n_i h_o$  = Thickness of  $i$ -th ply assembly (one or more plies having the same ply orientation  $\theta_i$ );  $i = 1, 2, \dots, m$ .
- $h_o$  =  $h/n$  = Unit ply thickness.
- $h_\theta$  =  $n_\theta h_o$  = Thickness of ply assembly having  $n$  plies at  $\theta$  ply orientation.
- $m$  =  $\cos \theta$ , or  
 = Total number of ply assemblies in a laminate.
- $N_i$  = Stress resultant, in  $N_m^{-1}$ ;  $i = 1, 2, 6$ .
- $n$  =  $\sin \theta$  or  
 = Total number of plies in a laminate =  $\sum_{i=1}^m n_i$
- $n_i$  =  $h_i/h_o$   
 = Number of plies in  $i$ -th ply assembly;  $i = 1, 2, \dots, m$ .

- $n_\theta$  =  $h_\theta/h_0$   
 = Number of plies having  $\theta$  ply orientation.
- $Q_{ij}^{(\theta)}$  = Modulus of ply assembly with  $\theta$  ply orientation.
- $Q_{ij}^{(i)}$  = Modulus of  $i$ -th ply assembly;  $i = 1, 2, \dots, m$ .
- $U_i$  = Linear combinations of modulus for the multiple-angle transformation;  $i = 1, 2, 3, 4, 5$ .
- $V_i$  = Integrals of trigonometric functions for the evaluation of the in-plane modulus;  $i = 1, 2, 3, 4$ .
- $v_\theta$  =  $n_\theta/n$   
 = Volume fraction of ply assembly with  $\theta$  orientation.
- $\bar{\sigma}_i$  =  $N_i/h$  = Average stress across thickness of a laminate;  
 $i = 1, 2, 6$ .
- $e_i^0$  = In-plane strain components;  $i = 1, 2, 6$ .

## 1. LAMINATE CODE

A multidirectional composite laminate is defined by the following code to designate the stacking sequence of ply assemblies:

$$\left[ 0_3 / 90_2 / 45 / -45_3 \right]_S \quad (140)$$

This code is represented diagrammatically in Fig. 46 and 47, and contains the following features:

- Starting from the bottom of the plate, at  $z = h/2$ , the first ply assembly has three plies of 0-degree orientation; followed by the next assembly with two 90-degree plies; followed by one 45-degree ply; and finally the last assembly with three -45-degree plies.
- The subscript  $S$  denotes that the laminate is symmetric with respect to the midplane or the  $z = 0$  plane. The upper half of the laminate is the same as the lower half except the stacking sequence is reversed in order to maintain the mid-plane symmetry.
- A subscript  $T$  is used to designate the total laminate, without any omission of the symmetrical upper portion of the laminate. If we want to describe the laminate in Eq. 140 using the total designation, we will have

$$\left[ 0_3 / 90_2 / 45 / -45_3 / -45_3 / 45 / 90_2 / 0_3 \right]_T \quad \text{or} \quad (141)$$

$$\left[ 0_3 / 90_2 / 45 / -45_6 / 45 / 90_2 / 0_3 \right]_T \quad (142)$$

In the last step, the two middle ply assemblies with -45 degree ply orientation were combined into one ply assembly.

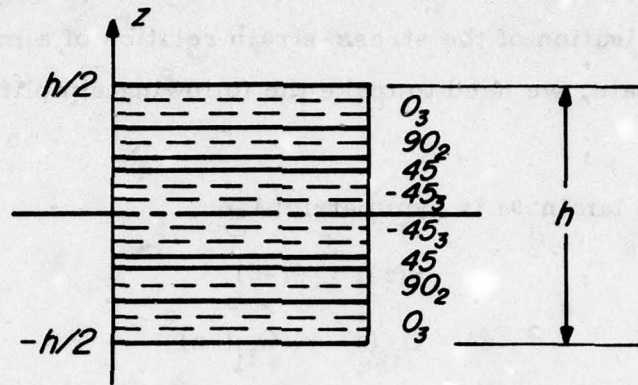

Fig. 46. Typical stacking sequence of a symmetric laminate. The laminate code as stated in Eq. 140 follows an ascending order from the bottom ply.

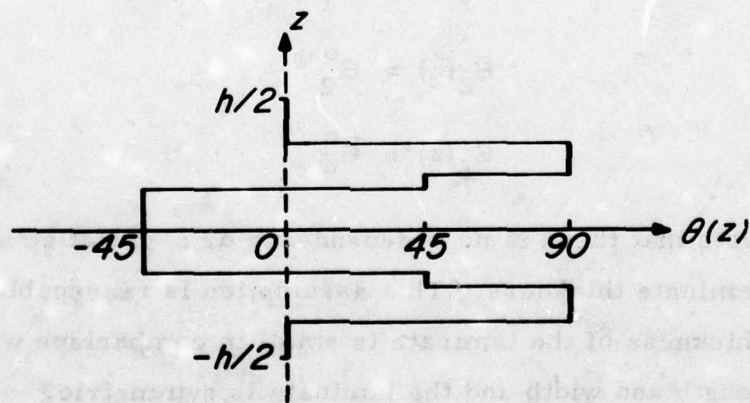

Fig. 47. Ply orientations as function of  $z$ . This is another representation of Fig. 46.

## 2. IN-PLANE STRESS-STRAIN RELATION FOR LAMINATES

In the derivation of the stress-strain relation of a multi-directional laminate, we need to make the following simplifying assumptions:

- The laminate is symmetric; i. e.,

$$\theta(z) = \theta(-z) \quad (143)$$

and 
$$Q_{ij}(z) = Q_{ij}(-z) \quad (144)$$

Thus, both the ply orientation and the ply material modulus are symmetric with respect to the midplane of the laminate.

- The strain remains constant across the laminate thickness. We will use superscript zero to signify the assumed constant in-plane strain components as follows:

$$\begin{aligned} \epsilon_1(z) &= \epsilon_1^0 \\ \epsilon_2(z) &= \epsilon_2^0 \\ \epsilon_6(z) &= \epsilon_6^0 \end{aligned} \quad (145)$$

Note that there is no z-dependency or z-variation across the laminate thickness. This assumption is reasonable when the thickness of the laminate is small in comparison with the length and width and the laminate is symmetric.

Since the stress distribution across the multidirectional laminate is not constant because the modulus varies from ply to ply, it is much easier to define an average stress than an actual stress across the laminate. This average stress can be used to define the stress-strain relation of the laminate. The stress, in this case, will be the average stress, and the strain, the in-plane strain in Eq. 145. We can then calculate the ply stress, or stress at any ply within the laminate from the in-plane strain. We will show this later after the stress-strain relation for the laminate is established. The average stress is defined as follows:

$$\left. \begin{aligned} \bar{\sigma}_1 &= \frac{1}{h} \int_{-h/2}^{h/2} \sigma_1 dz \\ \bar{\sigma}_2 &= \frac{1}{h} \int_{-h/2}^{h/2} \sigma_2 dz \\ \bar{\sigma}_6 &= \frac{1}{h} \int_{-h/2}^{h/2} \sigma_6 dz \end{aligned} \right\} \quad (146)$$

In Fig. 48, we show the relationship between the actual stress from ply to ply and the average stress across the laminate by the averaging process of Eq. 146.

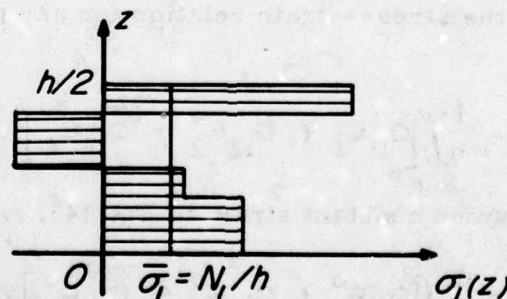

Fig. 48. Definition of average stress. Comparison between the corresponding components of the actual ply stress and the average laminate stress is shown.

Up to this point, we have used primed coordinates for the applied stress or strain, and unprimed coordinates for the material symmetry axes. This was shown in Fig. 34(a). When we go beyond the properties of unidirectional composites into laminated composites and structures, it is better to change our notation to the unprimed as the coordinates for our laminate or structures. A multidirectional laminate and its reference coordinate 1-2 are shown in Fig. 34(b) and repeated here in Fig. 49. Since there are many ply orientations in this laminate, we will have to identify the specific orientation for stress or strain transformation. The use of primed coordinates will not be adequate if more than one set of material symmetry axes exist.

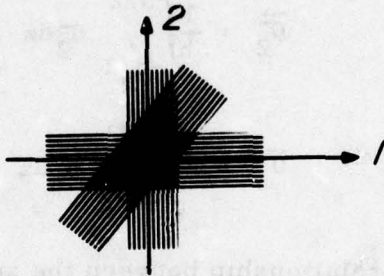

Fig. 49. Reference coordinate system 1-2 for typical multidirectional laminates. Differing from Fig. 34(a) the primed coordinates are not used here.

Substituting the stress-strain relation for any ply orientation into Eq. 146, we have

$$\bar{\sigma}_1 = \frac{1}{h} \int [Q_{11} \epsilon_1 + Q_{12} \epsilon_2 + Q_{16} \epsilon_6] dz \quad (147)$$

Substituting the assumed constant strain in Eq. 145, we have

$$\bar{\sigma}_1 = \frac{1}{h} \int [Q_{11} \epsilon_1^0 + Q_{12} \epsilon_2^0 + Q_{16} \epsilon_6^0] dz \quad (148)$$

Since the in-plane strain components are independent of  $z$ , we can factor them out of the integral signs. Only the modulus  $Q_{ij}$  is left inside the integral because the modulus varies from ply to ply depending on each ply orientation.

$$\bar{\sigma}_1 = \frac{1}{h} \int Q_{11} dz \epsilon_1^o + \int Q_{12} dz \epsilon_2^o + \int Q_{16} dz \epsilon_6^o \quad (149)$$

$$= \frac{1}{h} [A_{11} \epsilon_1^o + A_{12} \epsilon_2^o + A_{16} \epsilon_6^o] \quad (150)$$

Similarly, 
$$\bar{\sigma}_2 = \frac{1}{h} [A_{12} \epsilon_1^o + A_{22} \epsilon_2^o + A_{26} \epsilon_6^o] \quad (151)$$

$$\bar{\sigma}_6 = \frac{1}{h} [A_{16} \epsilon_1^o + A_{26} \epsilon_2^o + A_{66} \epsilon_6^o] \quad (152)$$

where

$$\left. \begin{aligned} A_{11} &= \int Q_{11} dz, & A_{22} &= \int Q_{22} dz \\ A_{12} &= \int Q_{12} dz, & A_{66} &= \int Q_{66} dz \\ A_{16} &= \int Q_{16} dz, & A_{26} &= \int Q_{26} dz \end{aligned} \right\} \quad (153)$$

where  $A_{ij}$  is the equivalent modulus for a multidirectional laminate. This modulus is simply the average of the modulus of the constituent plies. There is a difference of a length in the physical dimension of modulus  $Q_{ij}$  in Pa or  $\text{Nm}^{-2}$ ; and that of  $A_{ij}$  in  $\text{Nm}^{-1}$ .

We can further define stress resultants as

$$\left. \begin{aligned} N_1 &= h\bar{\sigma}_1 \\ N_2 &= h\bar{\sigma}_2 \\ N_6 &= h\bar{\sigma}_6 \end{aligned} \right\} \quad (154)$$

Note the unit of stress resultant is  $\text{Nm}^{-1}$ , or force per unit width of a laminate with thickness  $h$ . The in-plane stress-strain relation for laminates is actually the stress resultant versus in-plane strain relation. The latter is derived by combining Eq. 154 with 150 et al. We have:

$$\begin{aligned}
 N_1 &= A_{11}\epsilon_1^o + A_{12}\epsilon_2^o + A_{16}\epsilon_6^o \\
 N_2 &= A_{12}\epsilon_1^o + A_{22}\epsilon_2^o + A_{26}\epsilon_6^o \\
 N_6 &= A_{16}\epsilon_1^o + A_{26}\epsilon_2^o + A_{66}\epsilon_6^o
 \end{aligned}
 \tag{155}$$

This set of simultaneous equations can be inverted to yield the in-plane strain in terms of the stress resultant. This process is exactly the same as that described in Section 3.5, and the resulting determinant in Eq. 138, and the inverted modulus components or the compliance components in Eq. 139. In other words, Eq. 155 is based on modulus  $A_{ij}$  of the laminate, and we wish to find the corresponding compliance  $a_{ij}$  by inversion such that

$$\begin{aligned}
 \epsilon_1^o &= a_{11}N_1 + a_{12}N_2 + a_{16}N_6 \\
 \epsilon_2^o &= a_{12}N_1 + a_{22}N_2 + a_{26}N_6 \\
 \epsilon_6^o &= a_{16}N_1 + a_{26}N_2 + a_{66}N_6
 \end{aligned}
 \tag{156}$$

where  $a_{ij}$  take the place of  $S_{ij}$  in Table 29, and  $A_{ij}$  take the place of  $Q_{ij}$  in Table 22. We will show both stress-strain relations in Eq. 155 and 156 in matrix multiplication tables as follows:

Table 32. IN-PLANE STRESS-STRAIN RELATION OF SYMMETRIC LAMINATES IN TERMS OF MODULUS

	$\epsilon_1^o$	$\epsilon_2^o$	$\epsilon_6^o$
$N_1$	$A_{11}$	$A_{12}$	$A_{16}$
$N_2$	$A_{21}$	$A_{22}$	$A_{26}$
$N_6$	$A_{61}$	$A_{62}$	$A_{66}$

Table 33. IN-PLANE STRESS-STRAIN RELATION OF SYMMETRIC LAMINATES IN TERMS OF COMPLIANCE

	$N_1$	$N_2$	$N_6$
$\epsilon_1^0$	$a_{11}$	$a_{12}$	$a_{16}$
$\epsilon_2^0$	$a_{21}$	$a_{22}$	$a_{26}$
$\epsilon_6^0$	$a_{61}$	$a_{62}$	$a_{66}$

These stress-strain relations are valid for the in-plane deformation of symmetric laminates. If stress resultants are given, we can find the induced in-plane strain immediately from Table 33. Then the on-axis ply strain can be obtained by strain transformation from the initial 1-2 axes to the orientation of a specific ply or ply assembly. The ply stress is nothing more than the ply strain multiplied by the on-axis modulus. The complete process going from stress resultants to on-axis ply strain and ply stress is illustrated in Fig. 50.

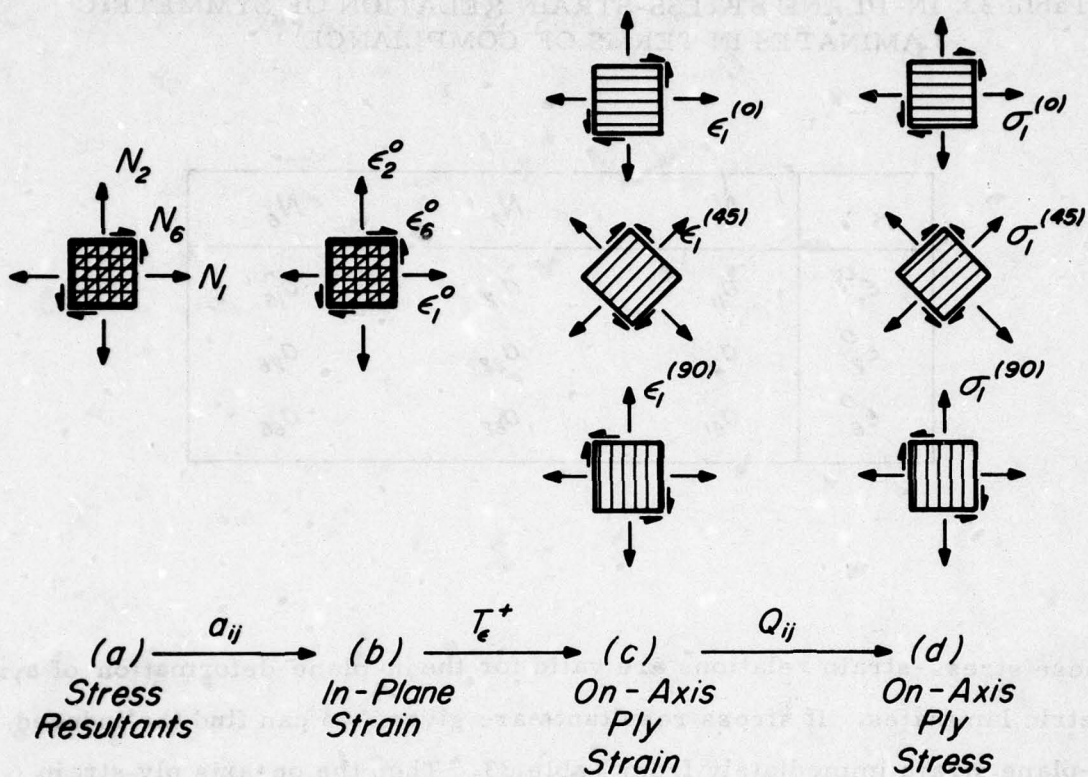

**Fig. 50.** On-Axis ply strain and stress calculations. From given stress resultants applied to a multidirectional laminate; we can go

From (a) to (b): use in-plane stress-strain relation in laminate compliance from Table 33.

From (b) to (c): use positive strain transformation in Tables 14 et al. The primed strain in Table 14 shall be replaced by in-plane strain  $\epsilon_1^0$ .

From (c) to (d): use the on-axis stress-strain relation of unidirectional composites in terms of modulus, in Table 6.

From the compliance  $a_{ij}$  in Table 33, we can calculate the effective engineering constants, following the process used in the off-axis unidirectional composites in Eq. 130, et al. We will have:

$$\begin{aligned}
 \text{In-plane longitudinal modulus} &= E_1^o = \frac{1}{a_{11}h} \\
 \text{In-plane transverse modulus} &= E_2^o = \frac{1}{a_{22}h} \\
 \text{In-plane Poisson's ratio} &= \nu_{12}^o = -\frac{a_{12}}{a_{11}} \\
 \text{In-plane shear modulus} &= G_{12}^o = \frac{1}{a_{66}h}
 \end{aligned}
 \tag{157}$$

Again we want to emphasize that engineering constants are the constants associated with simple tests such as uniaxial tensile and compressive tests and simple shear tests. They are the results of 1-dimensional tests and represent 1-dimensional characteristics of laminates. But composites are rarely used in 1-dimensional configuration. The 2-dimensional properties of composites are much different from the 1-dimensional properties of ordinary materials. Engineering constants are not easy to work with and can lead to big errors. We discussed this issue on off-axis unidirectional composites in Fig. 44, and will do it again on multidirectional laminates later in this section.

### 3. EVALUATION OF IN-PLANE MODULUS

We have only mentioned that the in-plane modulus of a multidirectional laminate is the arithmetic average of the off-axis modulus of the individual plies or ply assemblies. The averaging process is shown as integrals in Eq. 153. We will now describe the steps needed to perform the integrations so that the contribution of the ply modulus to the laminate modulus can be defined.

We want to mention again that we have made a change in the notation. The modulus in Eq. 153 is the off-axis modulus of unidirectional composites. No longer is primed modulus  $Q'_{ij}$  used to denote the off-axis orientation. We are now ready to evaluate the integrals in Eq. 153. The transformed modulus in Table 20 will be represented by the unprimed components in the following:

$$A_{11} = \int Q_{11} dz = \int [U_1 + U_2 \cos 2\theta + U_3 \cos 4\theta] dz \quad (158)$$

$$= U_1 \int dz + U_2 \int \cos 2\theta dz + U_3 \int \cos 4\theta dz \quad (159)$$

The  $U_i$  for a given composite remain constant. They can be factored out because they are not dependent on the z-axis.

$$A_{11} = U_1 h + U_2 V_1 + U_3 V_2 \quad (160)$$

Similarly,

$$A_{22} = U_1 h - U_2 V_1 + U_3 V_2 \quad (161)$$

where

$$V_1 = \int_{-h/2}^{h/2} \cos 2\theta dz \quad (162)$$

$$V_2 = \int_{-h/2}^{h/2} \cos 4\theta dz \quad (163)$$

We can repeat the process for other in-plane components.

$$\begin{aligned} A_{12} &= \int Q_{12} dz = \int [U_4 - U_3 \cos 4\theta] dz = U_4 h - U_3 \int \cos 4\theta dz \\ &= U_4 h - U_3 V_2 \end{aligned} \quad (164)$$

$$A_{66} = U_5 h - U_3 V_2 \quad (165)$$

$$\begin{aligned}
 A_{16} &= \int Q_{16} dz = \int \left[ U_2/2 \sin 2\theta + U_3 \sin 4\theta \right] dz \\
 &= \frac{1}{2} U_2 V_3 + U_3 V_4
 \end{aligned} \tag{166}$$

$$A_{26} = \frac{1}{2} U_2 V_3 - U_3 V_4 \tag{167}$$

where

$$V_3 = \int_{-h/2}^{h/2} \sin 2\theta dz \tag{168}$$

$$V_4 = \int_{-h/2}^{h/2} \sin 4\theta dz \tag{169}$$

We have seen that the evaluation of the in-plane modulus  $A_{ij}$  is reduced to the evaluation of four integrals, defined by  $V_1$  to  $V_4$ . These relations can be summarized in a matrix multiplication table as follows:

Table 34. FORMULAS FOR IN-PLANE MODULUS OF LAMINATES

	$h$	$U_2$	$U_3$
$A_{11}$	$U_1$	$V_1$	$V_2$
$A_{22}$	$U_1$	$-V_1$	$V_2$
$A_{12}$	$U_4$		$-V_2$
$A_{66}$	$U_5$		$-V_2$
$A_{16}$		$V_3/2$	$V_4$
$A_{26}$		$V_3/2$	$-V_4$

where the  $V_i$  can be defined as follows:

$$V_{[1,2,3,4]} = \int_{-h/2}^{h/2} [\cos 2\theta, \cos 4\theta, \sin 2\theta, \sin 4\theta] dz \tag{170}$$

This is a condensed definition of the  $V_i$  where the numerals in the bracket on the left-hand side applies to the corresponding term on the right-hand side of Eq. 170. The value of  $V_i$  are dependent on the variation of ply orientations in the multidirectional laminate. It is implicitly assumed that the laminate consists of plies of the same unidirectional composite. Because sine and cosine functions are bounded between -1 and +1, the  $V$ 's are bounded by the same limits, as we soon shall see. The similarity between Tables 34 and 20 is the result of the same transformation equations. In the limit when the laminate has only a ply orientation, we recover Table 20 from 34 because the integrants in Eq. 170 are constant. The  $V_i$  become simply the trigonometric functions times the laminate thickness:

$$\left. \begin{aligned} V_1 &= h \cos 2\theta \\ V_2 &= h \cos 4\theta \\ V_3 &= h \sin 2\theta \\ V_4 &= h \sin 4\theta \end{aligned} \right\} \quad (171)$$

Before we perform explicit integrations for the evaluation of  $V_i$  from Eq. 170, we must define the geometric quantities of a symmetric laminate in Fig. 51.

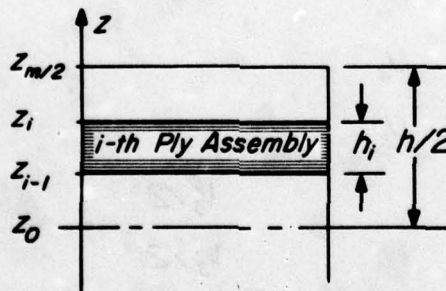

Fig. 51. Definitions of terms in a symmetric laminate.

The index for ply assembly goes from 0 to  $m/2$  when  $m$  is the total number of ply assemblies. The  $i$ -th ply assembly is located between  $z_{i-1}$  and  $z_i$ , and has a thickness  $h_i$ .

Let us now evaluate the first  $V_i$  in Eq. 170. We first normalize it with respect to the laminate thickness:

$$V_1^* = \frac{V_1}{h} = \frac{1}{h} \int_{-h/2}^{h/2} \cos 2\theta \, dz \quad (172)$$

If the laminate is symmetric, we only need to evaluate on half of the thickness, say, from  $z = 0$  to  $z = h/2$ . The new limits of integration call for a new interpretation of the laminate code as defined in Eq. 140. The starting point of the ascending ply sequence has been reversed from the  $z = 0$  to  $z = h/2$ . Only the upper half of a symmetric laminate needs to be evaluated. Thus,

$$V_1^* = \frac{2}{h} \int_0^{h/2} \cos 2\theta \, dz \quad (173)$$

Since each ply assembly is assumed to have the same ply orientation and material, this integration can now be replaced by summation as we move from ply assembly to ply assembly.

$$V_1^* = \frac{2}{h} \sum_{i=1}^{m/2} \cos 2\theta_i [z_i - z_{i-1}] \quad (174)$$

$$= \frac{2}{h} \sum_{i=1}^{m/2} \cos 2\theta_i h_i \quad (175)$$

where  $h_i$  = thickness of  $i$ -th ply assembly; where  $i$  begins from the midplane:

Let  $v_i$  = volume fraction of plies with  $\theta_i$  orientation

$$= 2h_i/h_0 \quad (176)$$

If each index  $i$  in Eq. 175 represents a unique ply orientation, we can now substitute Eq. 176 into 175.

$$V_1^* = \sum_{i=1}^{m/2} \cos 2\theta_i v_i \quad (177)$$

$$= v_1 \cos 2\theta_1 + v_2 \cos 2\theta_2 + v_3 \cos 2\theta_3 + \dots \quad (178)$$

where  $v_1 + v_2 + v_3 + \dots = 1 \quad (179)$

Thus,  $V_1^*$  is simply the rule of mixtures equation, or the weighted average of the  $\cos 2\theta$  functions. Since cosine functions can never be greater than unity (or less than minus unity), each term in Eq. 178 is always equal to or less than the corresponding term in 179. We can therefore conclude that  $V_1^*$  is bounded as follows:

$$-1 \leq V_1^* \leq 1 \quad (180)$$

By applying the identical process to the remaining  $V_i$  in Eq. 170, we can get the following:

$$V_2^* = v_1 \cos 4\theta_1 + v_2 \cos 4\theta_2 + v_3 \cos 4\theta_3 + \dots \quad (181)$$

$$V_3^* = v_1 \sin 2\theta_1 + v_2 \sin 2\theta_2 + v_3 \sin 2\theta_3 + \dots \quad (182)$$

$$V_4^* = v_1 \sin 4\theta_1 + v_2 \sin 4\theta_2 + v_3 \sin 4\theta_3 + \dots \quad (183)$$

With these simple equations, we can easily compute the in-plane modulus of multidirectional laminates with any ply orientations. The information needed is: each ply orientation and the volume fraction of that ply orientation; i. e.,  $\theta_i$  and  $v_i$ , respectively. Then from Eq. 178, 181-183, we can calculate the  $V_i^*$ . From Table 34 we can compute the  $A_{ij}$  for any multidirectional laminates.

When normalized  $V_i$  or  $V_i^*$  are used, Table 35 can be rewritten in a matrix multiplication table as follows:

Table 35. FORMULAS FOR NORMALIZED IN-PLANE MODULUS

	1	$U_2$	$U_3$
$A_{11}/h$	$U_1$	$V_1^*$	$V_2^*$
$A_{22}/h$	$U_1$	$-V_1^*$	$V_2^*$
$A_{12}/h$	$U_4$		$-V_2^*$
$A_{66}/h$	$U_5$		$-V_2^*$
$A_{16}/h$		$V_3^*/2$	$V_4^*$
$A_{26}/h$		$V_3^*/2$	$-V_4^*$

The units of normalized in-plane modulus will be the same as the modulus of unidirectional composites. Direct comparison between unidirectional and multidirectional composites is possible with the normalized in-plane modulus. If the laminate is unidirectional, the  $V_i$  are those listed in Eq. 171. Using the definition of the normalized  $V_i$  in Eq. 172, the values in Eq. 171 can be substituted into Table 35. We will recover the transformation relation of unidirectional composites in Table 20.

#### 4. CROSS-PLY LAMINATES

We will now examine some commonly encountered symmetric laminates and determine the values of their in-plane modulus and compliance.

First, we will study cross-ply composites. The ply orientations are limited to 0 and 90 degrees. In Table 36, all the values of the trigonometric functions which will be needed are listed.

Table 36. VALUES OF TRIGONOMETRIC FUNCTIONS FOR CROSS-PLY LAMINATES

$\theta_i$	$\cos 2\theta_i$	$\cos 4\theta_i$	$\sin 2\theta_i$	$\sin 4\theta_i$
0	1	1	0	0
90	-1	1	0	0

Substituting these trigonometric functions into Eq. 178, et al, we have

$$\left. \begin{aligned} V_1^* &= v_0 - v_{90} \\ V_2^* &= v_0 + v_{90} = 1 \\ V_3^* &= V_4^* = 0 \end{aligned} \right\} (184)$$

where  $v_\theta$  = the volume fraction of the  $\theta$  ply orientation. By taking these values and putting them into Table 35, we will have the normalized in-plane modulus for cross-ply composites as functions of volume ratios.

This is done in Table 37 where matrix multiplication is implied.

Table 37. FORMULAS FOR IN-PLANE MODULUS FOR CROSS-PLY COMPOSITES

	$U_1$	$U_2$	$U_3$
$A_{11}/h$	$U_1$	$v_0 - v_{90}$	$1$
$A_{22}/h$	$U_1$	$v_{90} - v_0$	$1$
$A_{12}/h$	$U_4$		$-1$
$A_{66}/h$	$U_5$		$-1$

$$A_{16} = A_{26} = 0$$

Note that only the first two components are affected by the volume fractions of the constituent plies in the laminate. The remaining four components are constant or zero. Cross-ply laminates are orthotropic because the shear coupling terms are zero. If we substitute the definitions of the  $U_i$  from Eq. 99 into the last two equations in Table 37, we will have:

$$\left. \begin{aligned} A_{12}/h &= U_4 - U_3 = Q_{12} \\ A_{66}/h &= U_5 - U_3 = Q_{66} \end{aligned} \right\} \quad (185)$$

Following are some numerical examples of the calculation of the in-plane modulus and compliance of cross-ply laminates. T300/5208 will be used as our sample material. The elastic modulus in terms of the  $U_i$  is listed in Table 22. Combining the modulus data with the formulas

in Table 37, we arrive at the following expressions:

$$\begin{aligned}
 A_{11}/h &= 76.37 + (v_0 - v_{90}) 85.73 + 19.71 \\
 A_{22}/h &= 76.37 - (v_0 - v_{90}) 85.73 + 19.71 \\
 A_{12}/h &= 22.61 - 19.71 = 2.90 \\
 A_{66}/h &= 26.88 - 19.71 = 7.17 \\
 A_{16} &= A_{26} = 0
 \end{aligned}
 \tag{186}$$

The results from these equations are plotted in Fig. 52, using the volume fraction of 90-degree plies as the abscissa. Note that the rule of mixtures relations apply in the first two components. Both are linear. The other two components in Eq. 186 are constant for all volume fractions.

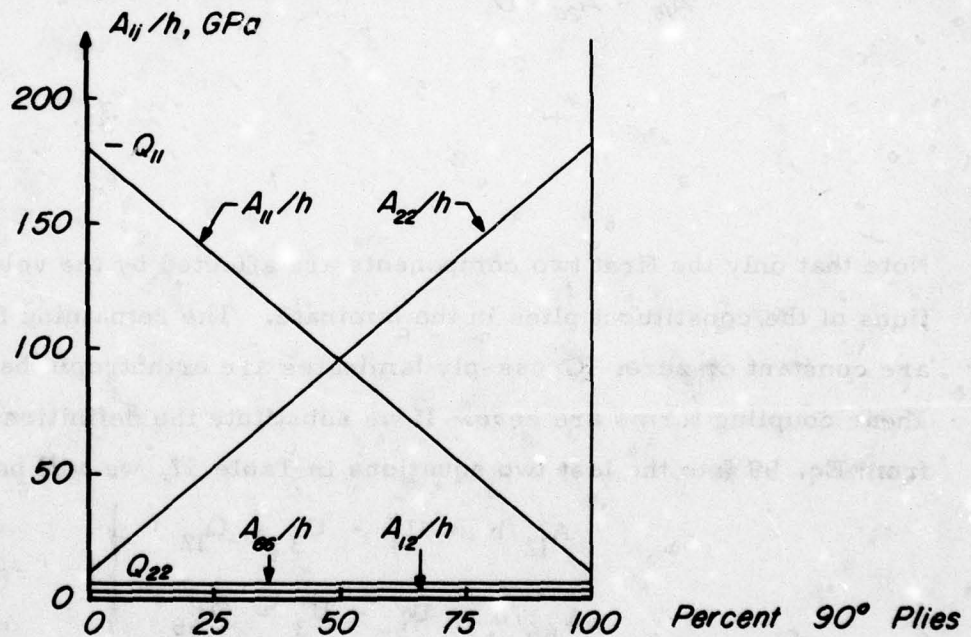

Fig. 52. In-plane modulus of cross-ply composites. Note all lines are straight indicating linear relationship as functions of 90-degree plies. The Poisson and shear components are constant and independent of volume fractions.

We can also calculate the compliance components by inverting the modulus at a given volume fraction. The inversion process though must be repeated for other fractions as well. Let us assume that the volume fractions are 50 percent. The modulus components are:

$$A_{11}/h = A_{22}/h = 96.08, A_{12}/h = 2.90, A_{66}/h = 7.17 \quad (187)$$

Using the matrix inversion method described in Eq. 138 and 139, we have the following solutions where we substitute  $A_{ij}/h$  for  $Q_{ij}$ , and the answer is  $a_{ij}^h$  in place of  $S_{ij}$ :

$$\begin{aligned} \det A_{ij} &= 66.126 \times 10^{30} h^3 (\text{Pa})^3 \\ a_{11}^h &= a_{22}^h = 10.41 (\text{TPa})^{-1} \\ a_{12}^h &= -.3141 \quad " \\ a_{66}^h &= 139.44 \quad " \\ a_{16} &= a_{26} = 0 \end{aligned} \quad (188)$$

These data, and similar data for other volume fractions of 90-degree plies, are plotted in Fig. 53. Note that the rule of mixtures or linear relation no longer exists. From the compliance components, we can get the following engineering constants using Eq. 157:

$$\begin{aligned} E_1^0 &= 1/10.41 = 96.0 \text{ GPa} \\ \nu_{12}^0 &= .3141/10.41 = .0301 \\ G_{12}^0 &= 1/139 = 7.17 \text{ GPa} \end{aligned} \quad (189)$$

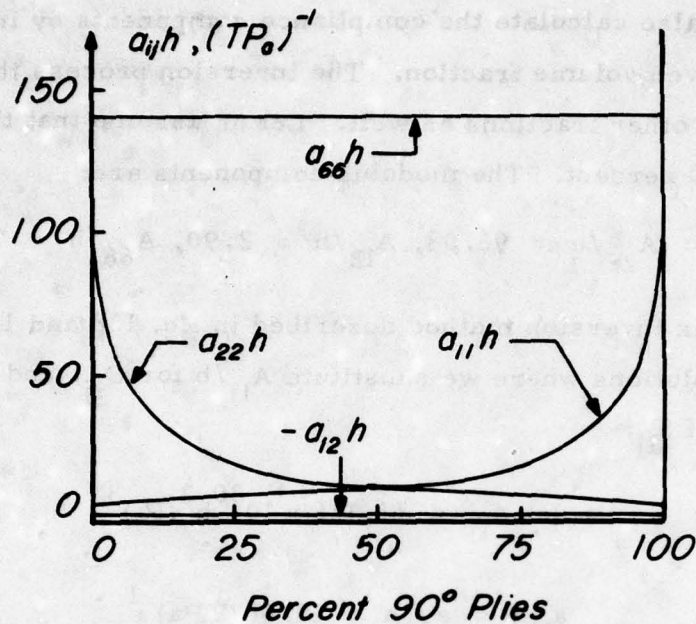

Fig. 53. In-plane compliance of cross-ply composites. Shear compliance is constant. Highly nonlinear relationship exists in the  $a_{11}$  and  $a_{22}$  so the rule of mixtures equation is not applicable. The Poisson compliance is also nonlinear but very small.

Since cross-ply laminates are orthotropic, we could have calculated and obtained the same engineering constants in Eq. 189 from those in-plane modulus components in Eq. 187 directly using the relations in Eq. 13.

$$E_1^o = \frac{Q_{11}}{m} = \frac{A_{11}/h}{m}$$

where

$$m = \left[ 1 - \frac{A_{12} A_{21}}{A_{11} A_{22}} \right]^{-1} = \left[ 1 - \frac{2.90^2}{96.08^2} \right]^{-1} = 1.001 \quad (190)$$

then

$$E_1^o = \frac{96.08}{1.001} = 96.0 \text{ GPa} \quad (191)$$

This agrees with the longitudinal modulus in Eq. 189.

The constraining effect of the 90 degree ply is responsible for the low Poisson's ratio in Eq. 189. Since the value of  $m$  in Eq. 190 is almost unity, therefore

$$A_{11}/h \approx E_1^0 \quad (192)$$

This is true only for cross-ply composites. Since  $A_{11}/h$  follows the rule of mixtures relation, we can say that  $E_1^0$  will follow approximately the same relation.

## 5. ANGLE-PLY LAMINATES

Angle-ply laminates form another very common group that deserves special attention. In this group, there are only two ply orientations which have the same magnitude but opposite signs. The laminate is balanced, which means that there are an equal number of plies in both the positive and negative ply orientations or, there exists a bisector.

Thus for angle-ply laminates we have:

$$\left. \begin{aligned} \theta_1 &= +\theta, \theta_2 = -\theta \\ \text{and} \quad v_1 &= v_2 = 1/2 \end{aligned} \right\} \quad (193)$$

Substituting these values into Eq. 178 et al,

$$\begin{aligned} V_1^* &= \frac{1}{2}(\cos 2\theta + \cos 2\theta) = \cos 2\theta \\ V_2^* &= \cos 4\theta \\ V_3^* &= V_4^* = 0 \end{aligned} \quad (194)$$

The formulas for the in-plane modulus for angle-ply laminates are listed in Table 38, where matrix multiplication is implied. They are obtained by substituting the values from Eq. 194 into Table 35.

Note that the first four rows of this table are identical to those in Table 20 for the unidirectional modulus  $Q_{ij}$ , except where the ply orientation  $\theta$  in Table 20 must be replaced by the angle  $\phi$  in the angle-ply laminate. The shear coupling terms vanish for the angle-ply laminate because of the last line in Eq. 192, or  $V_3 = V_4 = 0$ .

Table 38. FORMULAS FOR IN-PLANE MODULUS FOR ANGLE-PLY LAMINATES

	$U_1$	$U_2$	$U_3$
$A_{11}/h$	$U_1$	$\cos 2\phi$	$\cos 4\phi$
$A_{22}/h$	$U_1$	$-\cos 2\phi$	$\cos 4\phi$
$A_{12}/h$	$U_4$		$-\cos 4\phi$
$A_{66}/h$	$U_5$		$-\cos 4\phi$

$$A_{16} = A_{26} = 0$$

Because of the similarity between this table and Table 20, we can immediately convert the numerical results for T300/5208 in Fig. 35 by simply replacing  $\theta$  by  $\pm\phi$  and deleting the shear coupling terms. The comparable components of in-plane modulus for T300/5208 angle-ply laminates as functions of  $\pm\phi$  are equal to those in the first four columns in Table 22. The last two columns are zero. Like cross-ply laminates, angle-ply laminates are also orthotropic.

For [45/-45] angle ply, we have

$$\cos 2\phi = 0, \cos 4\phi = -1$$

Using the data for T300/5208 from Table 22, we have from the formulas for in-plane modulus in Table 38

$$\begin{aligned}
 A_{11}/h &= A_{22}/h = 76.37 - 19.71 = 56.66 \text{ GPa} \\
 A_{12}/h &= 22.61 + 19.71 = 42.32 \\
 A_{66}/h &= 26.88 + 19.71 = 46.59 \\
 A_{16} &= A_{26} = 0
 \end{aligned}
 \tag{195}$$

With the exception of these shear coupling terms, these values are identical to those for  $\theta = 45$  degrees in Table 22. The in-plane modulus of angle-ply laminates are listed in Table 39 and plotted in Fig. 54. Using the inversion method applied in Eq. 188, we have for the [45/-45] in Eq. 195:

$$\begin{aligned}
 \det A_{ij} &= 66.126 \times 10^{30} h^3 (\text{Pa})^3 \\
 a_{11}h &= a_{22}h = 39.91 (\text{TPa})^{-1} \\
 a_{12}h &= -29.81 \quad " \\
 a_{66}h &= 21.46 \quad " \\
 a_{16} &= a_{26} = 0 \quad "
 \end{aligned}
 \tag{196}$$

These compliance values together with those for other values of  $\theta$  are shown as solid lines in Fig. 55. The dashed lines are the transformed components of the compliance of unidirectional composites  $S_{ij}$  taken from Fig. 40. Components other than the shear coupling components between  $A_{ij}/h$  and the transformed  $Q_{ij}$  are identical as shown in Fig. 54. Complete differences, however, exist between  $a_{ij}h$  and the transformed  $S_{ij}$ . The solid versus dashed lines in Fig. 55 show these differences.

**Table 39. IN-PLANE MODULUS OF ANGLE-PLY LAMINATES  
OF T300/5208 (GPa)**

$\pm\theta$	$A_{11}/h$	$A_{22}/h$	$A_{12}/h$	$A_{66}/h$	$A_{16} = A_{26}$
0	181.8	10.3	2.90	7.17	0
15	160.4	11.9	12.75	17.05	0
30	109.3	23.6	32.46	36.78	0
45	56.6	56.6	42.32	46.59	0
60	23.6	109.3	32.46	36.78	0
75	11.9	160.4	12.75	17.05	0
90	10.3	181.8	2.90	7.17	0

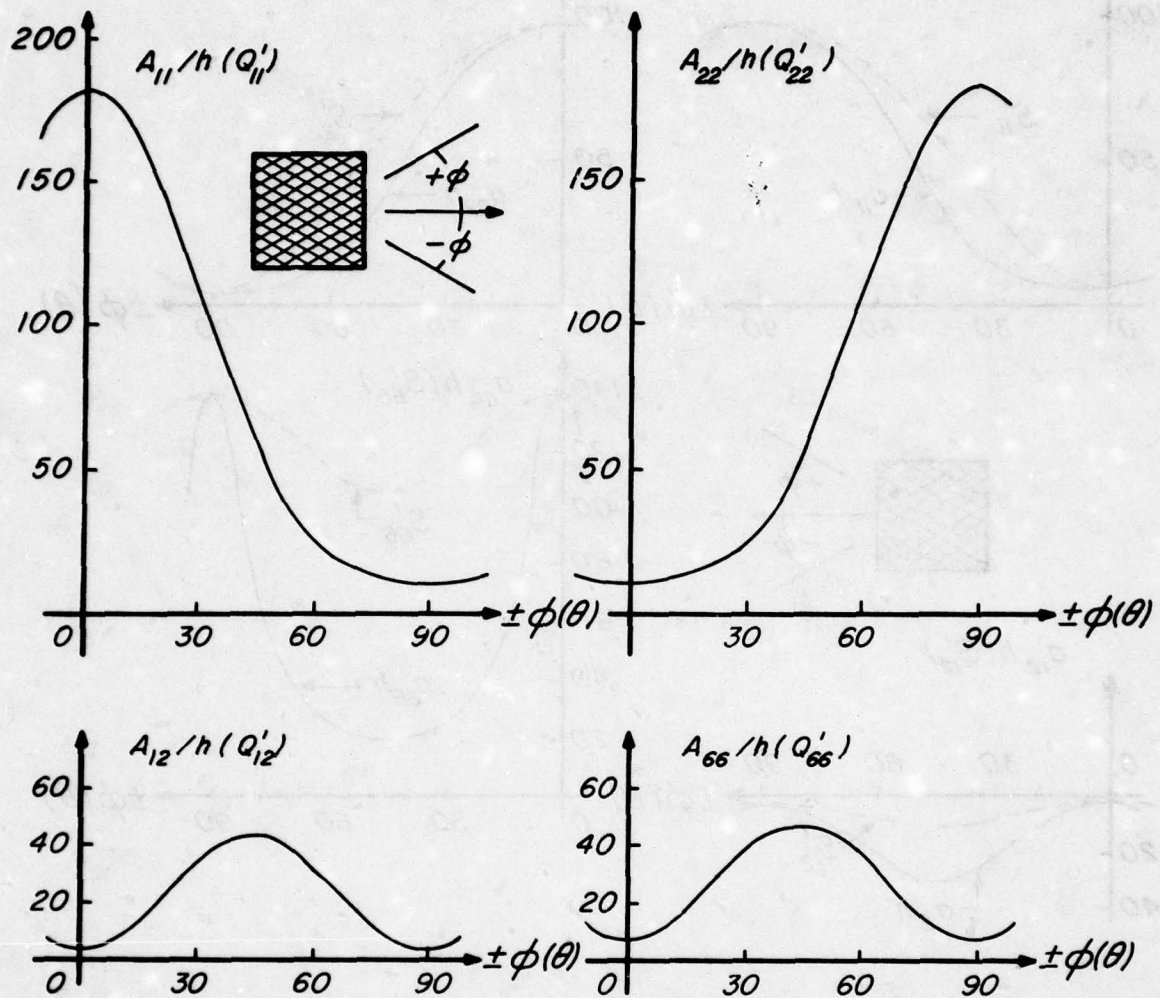

Fig. 54. In-plane modulus of angle-ply laminate of T300/5208 composite. With the exception of the non-zero shear coupling components, the curves above are identical to the transformed modulus of unidirectional T300/5108 shown in Fig. 35 where the coordinates are defined in the parenthesis. These curves here are the laminate modulus as a function of lamination angle  $\theta$ .

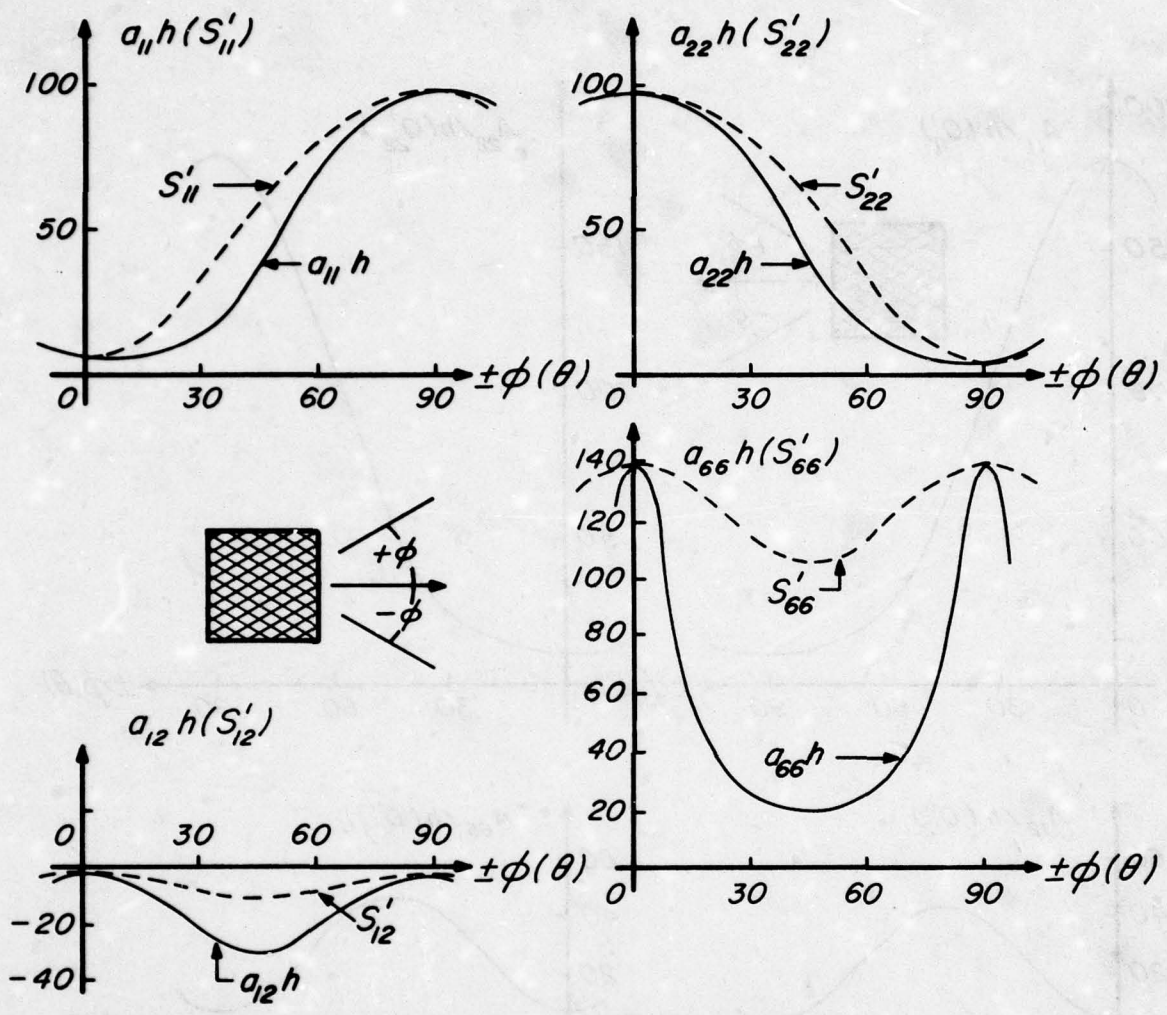

Fig. 55. In-plane compliance of T300/5208 angle-ply laminates. The solid lines are based on the data in Table 39, and are not transformation curves. The dashed lines, taken from Fig. 40, are the transformed components of compliance of the same unidirectional composite, with the coordinates defined in parenthesis; i. e.,  $\theta$  vs.  $S'_{ij}$ . Close similarity between  $A_{ij}/h$  and  $Q'_{ij}$  does not exist between  $a_{ij}h$  and  $S'_{ij}$ .

The engineering constants for off-axis unidirectional composites will also be completely different from those for angle-ply laminates. The engineering constants for  $\theta = 45$  degrees, which is simply the  $\pm 45$ -degree angle ply, can be obtained directly from the results in Eq. 196 using the relations in Eq. 157:

$$E_1^0 = E_2^0 = 1/a_{11}h = 39.91^{-1} = 25.05 \text{ GPa}$$

$$\nu_{12}^0 = -a_{12}/a_{11} = 29.81/39.91 = .746 \quad (197)$$

$$G_{12}^0 = 1/a_{66}h = 21.46^{-1} = 46.59 \text{ GPa}$$

The corresponding engineering constants for an off-axis unidirectional T300/5208 were calculated from the data in Table 29:

$$E_1' = E_2' = 59.75^{-1} = 16.73 \text{ GPa}$$

$$\nu_{12}' = 9.99/59.75 = .167 \quad (198)$$

$$G_{12}' = 105.7^{-1} = 9.46 \text{ GPa}$$

Compare like constants in Eq. 197 and 198. We see that the values for angle-ply laminates in Eq. 197 are much higher than the off-axis unidirectional in Eq. 198. The Poisson's ratios in Eq. 197 exceed the upper limit for ordinary materials, which is 1/2. This is theoretically admissible for non-isotropic materials. The comparison of these engineering constants between off-axis unidirectional and angle-ply laminates as functions of ply orientation  $\theta$  and lamination angle  $\pm\theta$  are shown in Fig. 56. The significant increase in the angle-ply laminates over that of the off-axis unidirectional over the entire range of angles is very apparent. The increase is caused by the constraining influence of a laminate. The plies are coupled and are not free to deform independently.

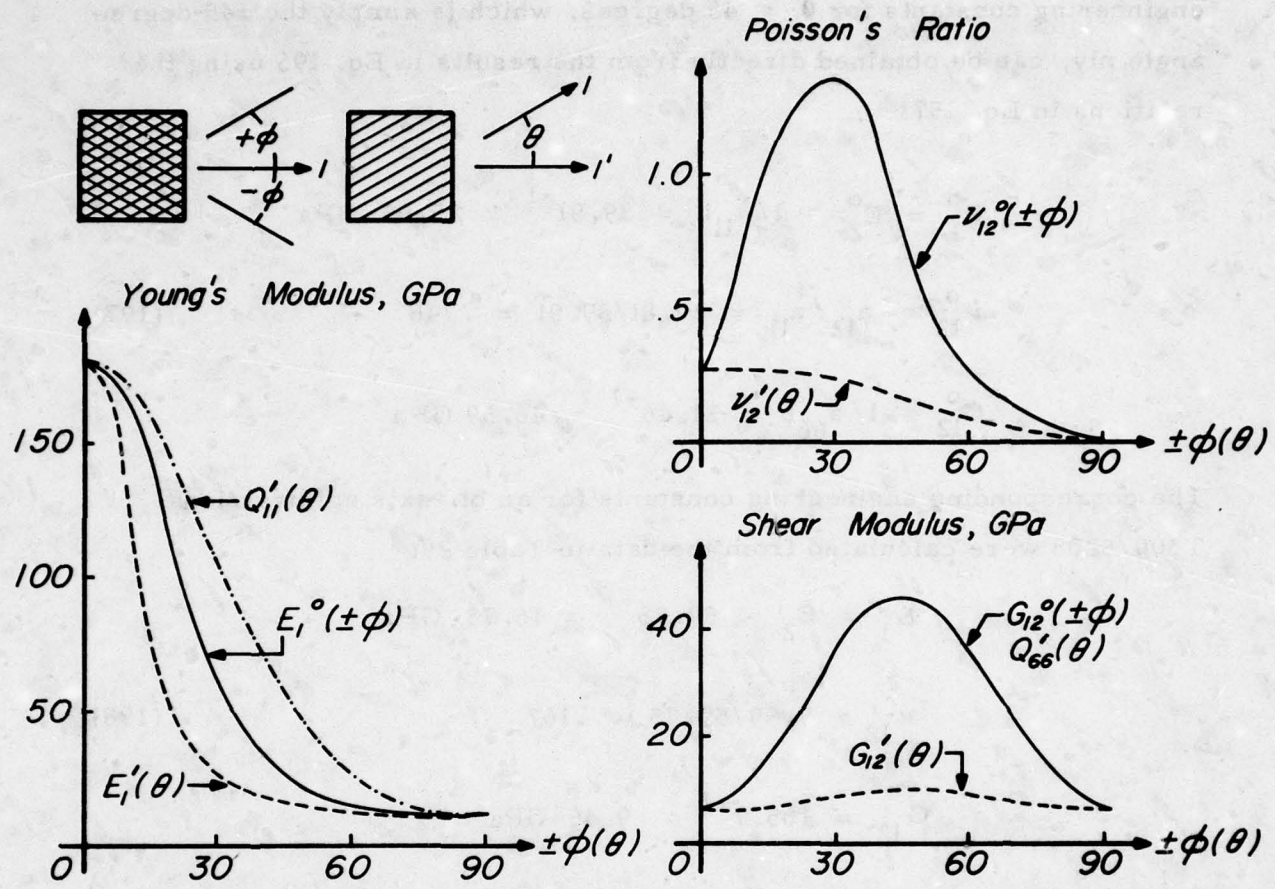

Fig. 56. Comparison between elastic constants of angle ply and unidirectional composites. The variations of elastic constants are shown as dashed and solid lines. The dashed lines are identical to those in Fig. 44.

## 6. QUASI-ISOTROPIC LAMINATES

If the following conditions for the in-plane modulus of a laminate are satisfied, the laminate is quasi-isotropic:

$$A_{11} = A_{22}, \quad 2A_{66} = A_{11} - A_{12} \quad (199)$$

The last relation is analogous to that for the modulus  $Q_{ij}$  in Eq. 23. This will become evident later. The two relations in Eq. 199 reduce the number of independent components of the in-plane modulus from four to two. This is a necessary condition for isotropy.

Intuitively, if ply orientations are random, we would expect an isotropic laminate. Directionality would disappear. For example, chopped fiber composites are quasi-isotropic. If we examine Eq. 170 which defines the  $V_i$ , it is reasonable to expect the integrated trigonometric functions to vanish. Physically, when there is equal probability of fibers oriented in any direction, or there is a continuous variation in fiber orientation, the cyclic terms in Table 34 as defined by the  $V_i$  will vanish. The in-plane modulus components will converge toward the invariants in the first column of the table. The in-plane modulus becomes:

$$\begin{aligned} A_{11}/h &= A_{22}/h = U_1 \\ A_{12}/h &= U_4 \\ A_{66}/h &= U_5 \end{aligned} \quad (200)$$

The conditions for isotropy in Eq. 199 are satisfied because of the relations between the invariants as described in Eq. 102. We have a quasi-isotropic material.

Since this is an isotropic material, we can find the quasi-isotropic engineering constants, as follows:

$$\begin{aligned} \text{From Eq. 13, } \nu_{LT} = \nu_{TL} = \nu &= \frac{A_{12}}{A_{11}} = \frac{U_4}{U_1} \\ G_{LT} = G &= A_{66}/h = U_5 \end{aligned} \quad \left. \vphantom{\begin{aligned} \nu_{LT} = \nu_{TL} = \nu \\ G_{LT} = G \end{aligned}} \right\} (201)$$

$$\text{From Eq. 23, } E = 2(1 + \nu)G = 2 \left[ 1 + \frac{U_4}{U_1} \right] U_5$$

If we use the values of  $U_i$  for T300/5208 from Table 2.2, we have

$$\begin{aligned} \nu &= 22.61/76.37 = .296 \\ G &= 26.88 \text{ GPa} \\ E &= 2(1 + .296) 26.88 = 69.67 \text{ GPa} \end{aligned} \quad \left. \vphantom{\begin{aligned} \nu \\ G \\ E \end{aligned}} \right\} (202)$$

There are other than random orientations that will produce quasi-isotropic laminates. Let us examine the following two laminates:

$$\left[ 0/60/-60 \right]_S, \text{ and } \left[ 0/90/45/-45 \right]_S$$

For the first laminate, we have from the definitions of  $V_i^*$  in Eq. 177 et al,

$$\begin{aligned} \nu_1 &= \nu_2 = \nu_3 = \frac{1}{3} \\ V_1^* &= \frac{1}{3} [\cos 0 + \cos 120 + \cos (-120)] = 0 \\ V_2^* &= \frac{1}{3} [\cos 0 + \cos 240 + \cos (-240)] = 0 \\ V_3^* &= \frac{1}{3} [\sin 0 + \sin 120 + \sin (-120)] = 0 \\ V_4^* &= \frac{1}{3} [\sin 0 + \sin 240 + \sin (-240)] = 0 \end{aligned} \quad \left. \vphantom{\begin{aligned} V_1^* \\ V_2^* \\ V_3^* \\ V_4^* \end{aligned}} \right\} (203)$$

For the second laminate, we have:

$$\begin{aligned}
 v_1 &= v_2 = v_3 = v_4 = \frac{1}{4} \\
 V_1^* &= \frac{1}{4} [\cos 0 + \cos 180 + \cos 90 + \cos (-90)] = 0 \\
 V_2^* &= \frac{1}{4} [\cos 0 + \cos 360 + \cos 180 + \cos (-180)] = 0 \\
 V_3^* &= \frac{1}{4} [\sin 0 + \sin 180 + \sin 90 + \sin (-90)] = 0 \\
 V_4^* &= \frac{1}{4} [\sin 0 + \sin 360 + \sin 180 + \sin (-180)] = 0
 \end{aligned}
 \left. \vphantom{\begin{aligned} V_1^* \\ V_2^* \\ V_3^* \\ V_4^* \end{aligned}} \right\} (204)$$

Since all the  $V_i^*$  are zero, the laminates are quasi-isotropic. In fact, we can generalize that any laminate with "m" ply assemblies spaced at ply orientations of "180/m" degrees will be quasi-isotropic. In the first case we had  $m = 3$ ; in the second case,  $m = 4$ . With symmetric laminates moreover, we must double the number of ply assemblies. The minimum number of plies are 6 and 8, respectively. The first laminate is also called  $\text{Pi}/3$ ; and the second  $\text{Pi}/4$ .

There is a very practical reason for quasi-isotropic laminates beyond being isotropic like ordinary materials. This configuration represents the minimum performance that we can expect. Since we may be uncomfortable in dealing with directionally varying properties, we can just use the quasi-isotropic laminate. A direct substitution of this laminate for the ordinary material can be done without hesitation, because this substitution is no different from substitution of any other ordinary materials.

The quasi-isotropic Young's modulus of T300/5208, as listed in Eq. 202, is equal to the Young's modulus of aluminum. But there is a minimum of 40 percent savings in weight. When directionality is judiciously added, the advantages of composites are overwhelming.

The quasi-isotropic laminates are used as the starting point of optimization of ply orientation. If minimum weight is a criterion, the quasi-isotropic laminate should be the upper bound of the weight. An optimized material taking full advantage of the directionality of properties should only have lower weight than the quasi-isotropic configuration.

#### 7. GENERALIZED PI/4 LAMINATES

This is a family of laminates having four ply orientations spaced at 45-degree intervals. The normal Pi/4 laminates have four ply assemblies with equal thickness and are therefore quasi-isotropic. Generalized Pi/4 laminates refer to those with arbitrary thicknesses in ply assemblies, including zero thickness for one or more ply assemblies. We will now list all the trigonometric functions and their values for our ply orientations in Table 40.

Table 40. VALUES OF TRIGONOMETRIC FUNCTIONS FOR IN-PLANE MODULUS OF GENERALIZED PI/4 LAMINATES

$\theta_i$	$\cos 2\theta_i$	$\cos 4\theta_i$	$\sin 2\theta_i$	$\sin 4\theta_i$
0	1	1	0	0
90	-1	1	0	0
45	0	-1	1	0
-45	0	-1	-1	0

Substituting these values into Eq. 177 et al, we have

$$\left. \begin{aligned} V_1^* &= v_0 - v_{90} \\ V_2^* &= v_0 + v_{90} - v_{45} - v_{-45} \\ V_3^* &= v_{45} - v_{-45} \\ V_4^* &= 0 \end{aligned} \right\} (205)$$

With these values, the formulas for in-plane modulus in Table 35 can be specialized for our generalized Pi/4 laminates. This is done in a matrix multiplication table as follows:

Table 41. FORMULAS FOR IN-PLANE MODULUS OF GENERALIZED PI/4 LAMINATES

	$U_1$	$U_2$	$U_3$
$A_{11}/h$	$U_1$	$v_0 - v_{90}$	$v_0 + v_{90} - v_{45} - v_{-45}$
$A_{22}/h$	$U_1$	$-v_0 + v_{90}$	$v_0 + v_{90} - v_{45} - v_{-45}$
$A_{12}/h$	$U_4$		$-v_0 - v_{90} + v_{45} + v_{-45}$
$A_{66}/h$	$U_5$		$-v_0 - v_{90} + v_{45} + v_{-45}$
$A_{16}/h$		$\frac{1}{2}[v_{45} - v_{-45}]$	
$A_{26}/h$		$\frac{1}{2}[v_{45} - v_{-45}]$	

Note when all the  $v_i$  are equal, we recover the quasi-isotropic laminates. When the 45-degree plies are zero, we recover the formulas for cross-ply laminates listed in Table 37. When we have a special angle-ply laminate with the lamination angle  $\theta$  equal to 45 degrees, we recover from Table 41 the special  $\pm 45$  laminate from Table 38. Finally,  $\pi/4$  laminates are orthotropic when the 45-degree plies are balanced, or when

$$v_{45} = v_{-45} \quad (206)$$

When this is true, the shear coupling components become zero.

The formulas in Table 41 can be represented by a series of diagrams or plots. First of all, the components of modulus are all linear functions of the ply fractions. The components are proportional to four linear combinations of the ply fractions; viz.,  $v_0$ ,  $v_{90}$ ,  $v_{45} + v_{-45}$  and  $v_{45} - v_{-45}$ . In Fig. 56 we show the in-plane modulus of generalized  $\pi/4$  laminates for T300/5208 composite. The first chart shows component  $A_{11}/h$ . This chart is valid for balanced as well as unbalanced laminates; i. e., independent of the values of  $v_{45}$  and  $v_{-45}$ . The same can be applied to the second chart on components  $A_{12}/h$  and  $A_{66}/h$ . Component  $A_{22}/h$  is not shown because it can be found by interchanging  $v_0$  with  $v_{90}$  from the  $A_{11}/h$  chart. Only in unbalanced laminate, that is the +45 has different number of plies from -45, will the last chart in Fig. 57 become necessary.

The open hexagon in each diagram represents the properties of the quasi-isotropic laminate. Note all relationships in Table 41 are described by straight lines. This did not happen by accident. In fact, it is important to choose the correct parameters so linear relationships exist between the ply and the laminate properties. The correct property set for the case of stiffness of the laminate is the components of modulus  $Q_{ij}$  of the unidirectional composites. If another property set is chosen, nonlinear relationship would result. When the property set consisting of engineering constants are chosen, the straight lines in Fig. 57 will be replaced by curved lines. In fact the curved lines have been referred to by a trade

name: the carpet plot. The moral of the story is that modulus is the simplest property for the description of the stiffness of laminated composites. The carpet plot is an unnecessarily complicated way of showing properties of composites.

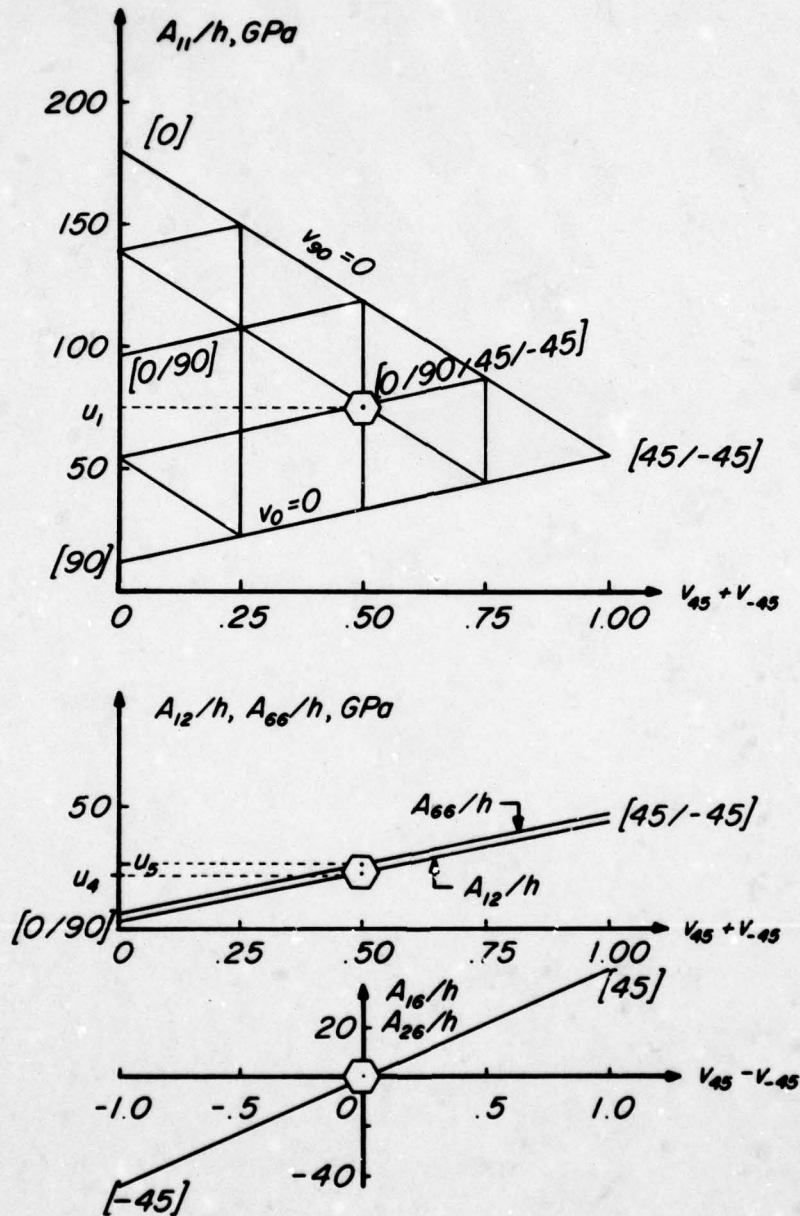

Fig. 57. In-plane modulus of generalized  $\pi/4$  laminates of T300/5208 composite. Quasi-isotropic points are shown as open hexagons.

SECTION V

FLEXURAL STIFFNESS OF SYMMETRIC SANDWICH LAMINATES

SCOPE

The flexural stiffness of symmetric sandwich laminates with honeycomb core and multidirectional composite facing will be covered. The strain in the laminate is defined as linearly proportional to the curvature. Flexural rigidity can then be defined as the modulus for flexural stiffness and can be related to the bending-curvature relation. The contribution of the core and the effect of stacking sequence on the flexural rigidity will also be discussed. The key relation for the flexural modulus of any laminate with or without core is:

	$h^{*3}$	$U_2$	$U_3$
$D_{11}$	$U_1$	$V_1$	$V_2$
$D_{22}$	$U_1$	$-V_1$	$V_2$
$D_{12}$	$U_4$		$-V_2$
$D_{66}$	$U_3$		$-V_2$
$D_{16}$		$V_3/2$	$V_4$
$D_{26}$		$V_3/2$	$-V_4$

where  $h^{*3} = (1 - z_c^{*3})h^3/12$

## PRINCIPAL NOMENCLATURE

- b** = The width of beams
- $D_{ij}$**  = Flexural modulus of multidirectional laminates, with or without core, in Nm;  $i, j = 1, 2, 6$ .
- $D_{ij}^*$**  =  $D_{ij}/h^3$  or  $12D_{ij}/h^3$  when  $z_c = 0$ .
- $d_{ij}$**  = Flexural compliance of multidirectional laminates, and is the inverse of  $D_{ij}$ , in  $(\text{kNm})^{-1}$ ;  $i, j = 1, 2, 6$ .
- $E_1^f$**  = A flexural engineering constant: the effective Young's modulus along the 1-axis, in GPa.
- $E_2^f$**  = A flexural engineering constant: the effective Young's modulus along the 2-axis, in GPa.
- $G_{12}^f$**  = A flexural engineering constant: the effective longitudinal shear modulus, in GPa.
- h** = Total thickness of laminate, with or without core, in m.
- $h^{*3}$**  =  $h^3[1 - z_c^3]/12$
- $h_i$**  =  $n_i h_o$  = Total thickness of the  $i$ -th ply assembly;  $i = 1, 2, \dots, m$
- $h_o$**  =  $(h - 2z_c)/n$  = Unit ply thickness
- I** = Momen of inertia
- $k_i$**  = Curvature, in  $\text{m}^{-1}$ ;  $i = 1, 2, 6$ .
- m** = Total number of ply assemblies in a laminate.
- $M_i$**  = Moment, in  $\text{Nm}^{-1}$ ;  $i = 1, 2, 6$ .
- n** = Total number of plies in a laminate.
- $n_i$**  = Total number of plies in the  $i$ -th ply assembly;  $i = 1, 2, \dots, m$ .
- $Q_{ij}^{(i)}$**  = Modulus of the  $i$ -th ply assembly, in GPa;  $i, j = 1, 2, 6$ .
- $Q_{ij}^{(\theta)}$**  = Modulus of the ply assembly with  $\theta$  orientation;  $i, j = 1, 2, 6$ .
- $U_i$**  = Linear combinations of modulus for the multiple-angle transformation of modulus, in GPa;  $i = 1, 2, 3, 4, 5$ .

$V_i$  = Integrals of trigonometric functions in formulas for flexural modulus;  $i = 1, 2, 3, 4$ .

$V_i^*$  =  $12V_i/h^3$

$z_c$  = Half depth of honeycomb core.

$z_c^*$  =  $2z_c/h$

= Total core to total laminate thickness ratio.

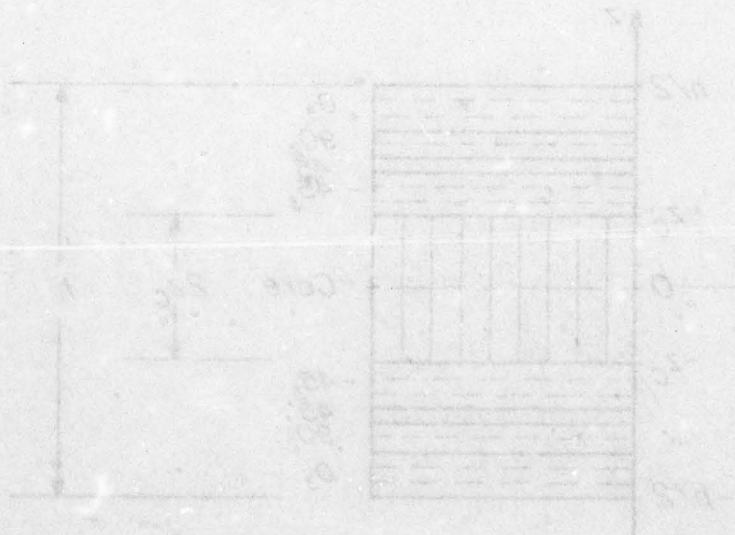

1. LAMINATE CODE

The same laminate code convention as that used for the in-plane modulus in Eq. 140 will be followed for the flexural modulus. For symmetric laminates we can add the half depth of the core in the code; for example:

$$\left[ 0_3 / 90_2 / 45 / -45_3 / z_c \right]_S \quad (207)$$

The orientations, ply assemblies and the core for this laminate are shown in Fig. 58. The plies are arranged in an ascending order from the bottom or the  $z = -h/2$  face. This again can be a source of confusion. The code in Eq. 207 applies to the lower half of a symmetric laminate starting from the bottom face. The stacking sequence in the upper half of the laminate is in reverse order of the code shown in Eq. 207. The actual integration for the calculation of the flexural modulus is applied over the upper half of the laminate which extends from  $z = 0$  to  $z = h/2$ .

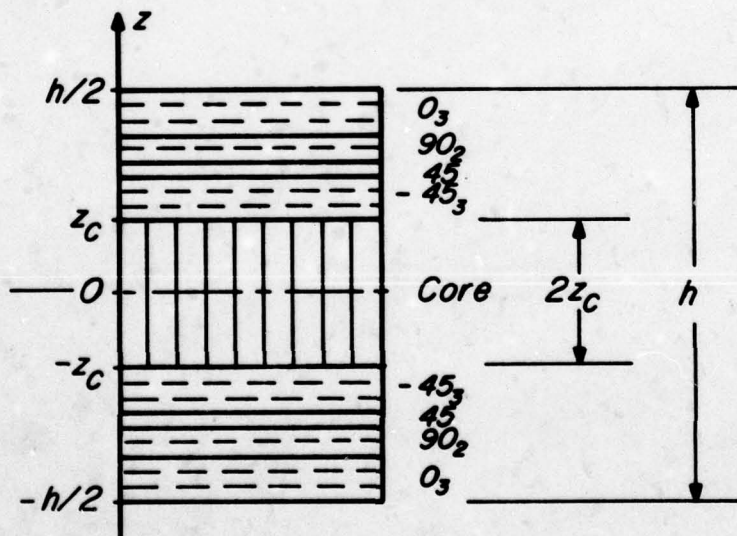

Fig. 58. Dimensions and stacking sequence of symmetric sandwich laminates.

In the case of the in-plane modulus, only the volume fractions of the ply assemblies are important. This is clearly shown in Eqs. 153 and 170. The actual stacking sequence does not affect the in-plane modulus. Whether the laminate code is intended to follow an ascending or descending order is of no consequence to the in-plane modulus. This, however, is no longer true for the flexural modulus that we will discuss in the section. The positions of ply assemblies in a laminate have direct effect on the flexural modulus. That is why we are discussing the laminate code again.

## 2. MOMENT-CURVATURE RELATIONS

In the flexural behavior of laminates, moment and curvature are the key variables, similar to the role of stress resultant and in-plane strain in the in-plane behavior of the last section. The counterpart of the stress-strain relation for the in-plane behavior is the moment-curvature relation for the flexural behavior. The elastic constants for the latter relation will be called the flexural modulus and flexural compliance. It is the purpose of this section to develop definitions of moment and curvature, and their relationship to each other.

The distribution of ply stresses can be symmetric and antisymmetric with respect to the midplane. In Section 4, the stress distribution was symmetric and this was shown in Fig. 48. In Fig. 59 we will repeat the symmetric distribution of Fig. 48, and will also show the case of antisymmetric distribution.

As the result of symmetric stress distribution in Fig. 59(a), we can represent the variable stress by an average stress  $\bar{\sigma}_1$  or stress resultant  $N_1$ . The in-plane behavior of symmetric laminates can be completely characterized using the average stress or stress resultant. When the stress distribution is anti-symmetric, as shown in Fig. 59(b), the average stress across the entire laminate thickness is zero. One approach of dealing with the anti-symmetric stress distribution is to define a new quantity: the moment, to take the place of stress resultant. The simplest or first moment has three components:

$$\begin{aligned}
 M_1 &= \int_{-h/2}^{h/2} \sigma_1 z dz \\
 M_2 &= \int_{-h/2}^{h/2} \sigma_2 z dz \\
 M_6 &= \int_{-h/2}^{h/2} \sigma_6 z dz
 \end{aligned}
 \quad \left. \vphantom{\begin{aligned} M_1 \\ M_2 \\ M_6 \end{aligned}} \right\} (208)$$

The unit of moment is N, or Nm/m; i. e., a moment per unit width of a laminate with thickness  $h$ .

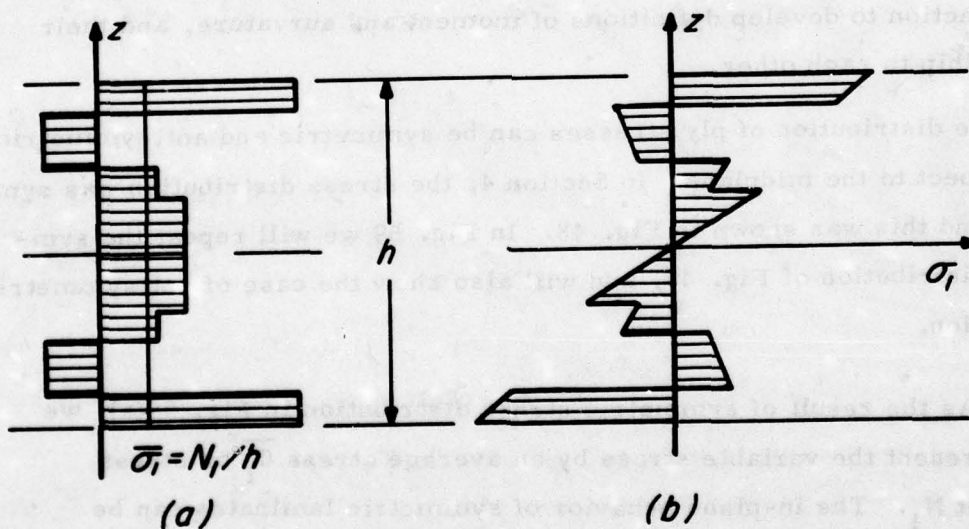

Fig. 59. Stress variations across laminates. Illustration of symmetric ply stresses in (a), and antisymmetric ply stresses in (b).

The sign of the components of moment is also critical. The bending components of moment, like the normal components of stress and strain, are easy to rationalize and readily defined. A bending moment is positive if the average induced stress in the upper half of the laminate is positive. In Fig. 60(a) we define the positive component for  $M_1$ ; in Fig. 60(b), the positive  $M_2$ . When  $M_1$  or  $M_2$  is negative, the average induced stress in the upper half of the laminate will be negative. We use average stress here because in a laminated material it is possible to have both positive and negative stresses in each half of the laminate. Fig. 59(b) shows this possibility.

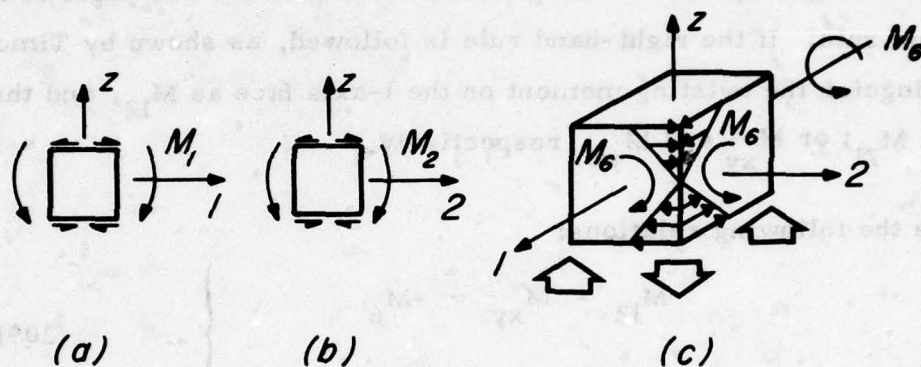

Fig. 60. The positive directions of components of moment.

Bending moments are shown in (a) and (b).

In (c), the positive twisting moment is shown and the induced shear stresses are idealized as linear in the  $z$  coordinate.

Note positive twisting moment appears as clockwise torque on the positive 1-axis face; counterclockwise on the positive 2-axis face. The right-hand rule is not invoked here. The effect of the positive twisting moment can be duplicated by four self-equilibrating forces acting at the corners as shown. These arrows are useful in determining the direction of twisting as illustrated in Fig. 25 by Timoshenko and Woinowsky-Krieger\*.

---

\*S. Timoshenko and S. Woinowsky-Krieger, Theory of Plates and Shells, McGraw-Hill, 1959, pp. 80-81

The sign convention for twisting moment  $M_6$  follows the same rule; viz., a positive shear stress on the upper half of the laminate is associated with the positive twisting moment. The positive shear stress component is defined in Fig. 6. Fig. 60(c) shows the result of positive twisting moment and the induced shear stress distribution. All the arrows will reverse their directions if the twisting moment is negative. We are not imposing the right-hand rule for the sign convention except that the coordinates and angle of rotation follow this rule. If the right-hand rule is followed, as shown by Timoshenko, we must distinguish the twisting moment on the 1-axis face as  $M_{12}$ , and that on the 2-axis as  $M_{21}$ ; or  $M_{xy}$  and  $M_{yx}$ , respectively.

Then we have the following relations:

$$\left. \begin{aligned} M_{12} &= M_{xy} = -M_6 \\ M_{21} &= M_{yx} = M_6 \end{aligned} \right\} \quad (209)$$

Therefore  $M_{12} = -M_{21} \quad (210)$

The important issue here is not what sign convention we use. We must understand the rationale and be consistent. Again we would like to mention how critical signs are when we work with composite materials. A wrong guess is often inconsequential for ordinary materials, but can be disastrous for composites. The signs for shear stress, shear strain, twisting moment here and twisting curvature, which we will introduce presently, are all sources of uncertainty and error.

We will now derive the strain-displacement relation for the bending of a plate similar to that for the in-plane stretching of a plate in Eq. 1 and 4.

We will assume that the plate is initially flat as shown in Fig. 61(a). After bending, the plate can be described by a function  $w$  where:

$$w = w(x, y) \quad (211)$$

It is implied that the vertical displacement of each point does not vary in the  $z$ -direction. The normal to the plate does not stretch or deform. It only rotates as the plate is bent or twisted. Fig. 61(b) is an illustration of a bent plate.

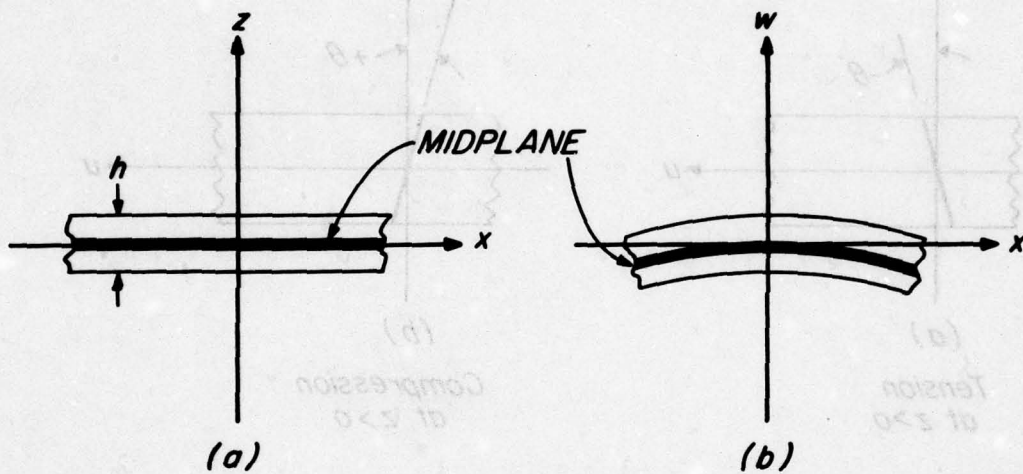

Fig. 61. Definition of a plate or laminate before and after bending.

The deformed midplane is described by a function  $w(x, y)$ .

The rotation of the normal to the midplane can be directly related to the first derivative at the same point in the plate. This is shown in Fig. 62, where two cases of the bent plane is shown for the purpose of establishing the correct sign convention. Consistency between Fig. 60 and 61 is maintained if we recognize that a change in sign in the derivation is necessary.

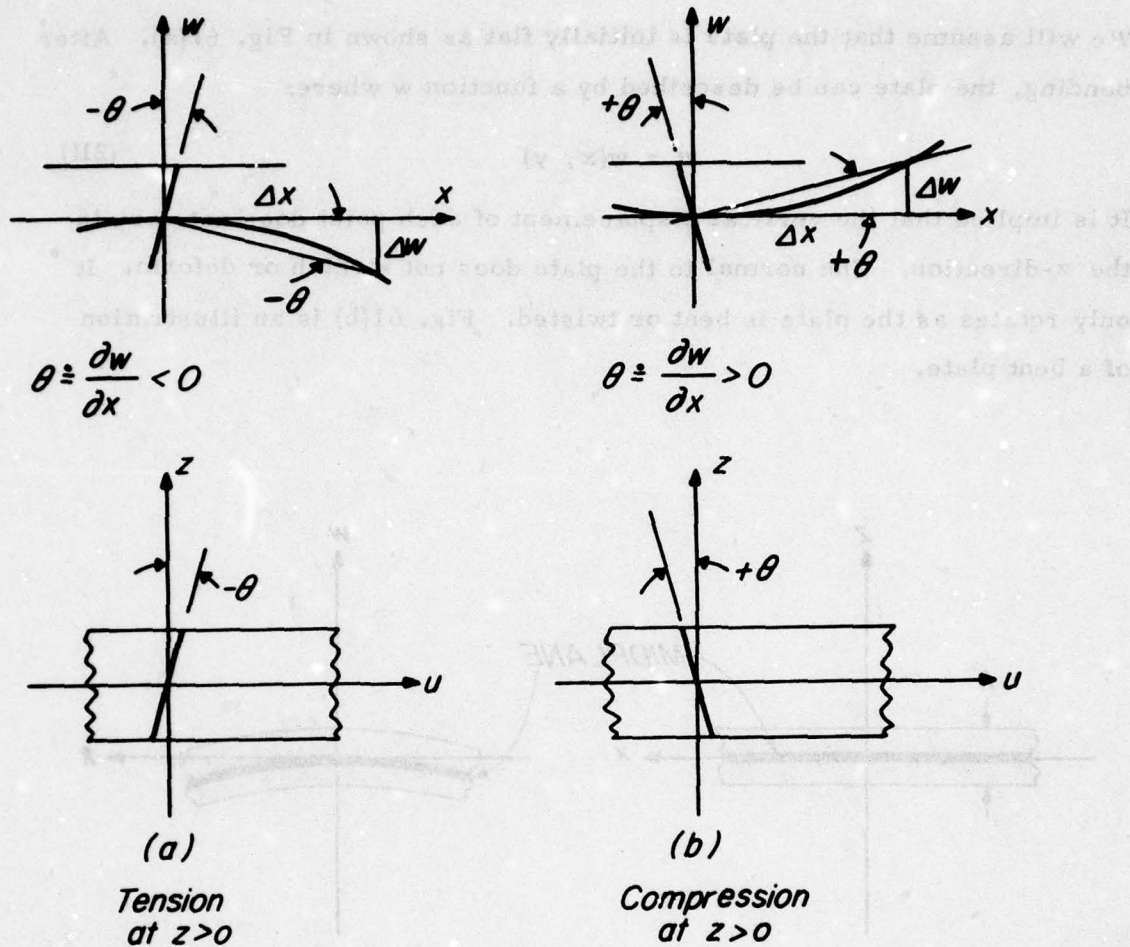

Fig. 62. Sign convention of midplane displacements. For a concave downward deformation in (a), the derivative of  $w$  is negative, and a negative sign must be added to the displacement-derivative relation in Eq. 212. When the curvature is reversed in (b), the derivative of  $w$  is now positive.

The definition of displacement-derivative relation is:

$$u = -z\theta = -z \frac{\partial w}{\partial x} \quad (212)$$

Similarly, we can derive the displacement along the  $y$ -axis as:

$$v = -z \frac{\partial w}{\partial y} \quad (213)$$

From the last two equations, and the strain-displacement relations of Eq. 1 and 4, we can show that:

$$\left. \begin{aligned} \epsilon_1 &= \frac{\partial u}{\partial x} = -z \frac{\partial^2 w}{\partial x^2} \\ \epsilon_2 &= \frac{\partial v}{\partial y} = -z \frac{\partial^2 w}{\partial y^2} \\ \epsilon_6 &= \frac{\partial u}{\partial y} + \frac{\partial v}{\partial x} = -2z \frac{\partial^2 w}{\partial x \partial y} \end{aligned} \right\} \quad (214)$$

We can relate the second derivatives to curvatures  $k_i$  as follows:

$$\left. \begin{aligned} k_1 &= -\frac{\partial^2 w}{\partial x^2} \\ k_2 &= -\frac{\partial^2 w}{\partial y^2} \\ k_6 &= -2\frac{\partial^2 w}{\partial x \partial y} \end{aligned} \right\} \quad (215)$$

The bending curvatures are the reciprocals of the radii of curvature. The relations in Eq. 215 can be found in elementary calculus, and can be related to simple graphical illustrations. The sign convention used here is based on that established in Fig. 60. The twisting curvature is difficult to illustrate and is not normally covered in elementary text. We derived our relation through the use of the strain-displacement relation in Eq. 4. Substituting the definitions in Eq. 215 into 214, we have:

$$\left. \begin{aligned} \epsilon_1(z) &= zk_1 \\ \epsilon_2(z) &= zk_2 \\ \epsilon_6(z) &= zk_6 \end{aligned} \right\} \quad (216)$$

This assumed linear strain distribution is shown in Fig. 63. A more general assumed state of strain than both Eq. 145 and 216 would be the sum of the two. This combined strain will be used as the basis of general, nonsymmetrical laminates which we will cover in the future.

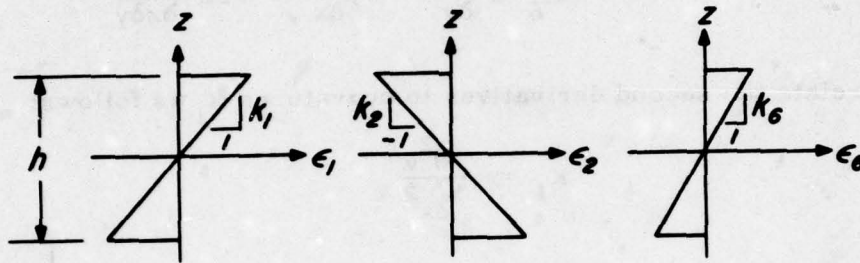

Fig. 63. Assumed linear strain distribution across laminate thickness. Maximum strain values reached at the upper and lower faces. They are equal but opposite in signs when the laminate is symmetric.

We can now derive the moment-curvature relations by substituting the assumed strain into the definition of moment in Eq. 208. We must first, however, substitute the off-axis stress-strain relations listed in Table 18 or 30 into Eq. 208. This will express the stress components in terms of the strain components. As we did in the derivation of the in-plane stress-strain relations, we deleted the primes from all the relations in Table 18 for the sake of simplicity; that was also done in Table 30.

From Eq. 208  $M_1 = \int \sigma_1 z dz$

From Table 30  $= \int [Q_{11} \epsilon_1 + Q_{12} \epsilon_2 + Q_{16} \epsilon_6] z dz$  (217)

From Eq. 216  $= \int [Q_{11} k_1 + Q_{12} k_2 + Q_{16} k_6] z^2 dz$  (218)

Since  $k_i$  are constant, not dependent on  $z$ , they can be factored out,

$$M_1 = \left[ \int Q_{11} z^2 dz \right] k_1 + \left[ \int Q_{12} z^2 dz \right] k_2 + \left[ \int Q_{16} z^2 dz \right] k_6$$

$$M_1 = D_{11} k_1 + D_{12} k_2 + D_{16} k_6$$

Similarly:

$$M_2 = D_{12} k_1 + D_{22} k_2 + D_{26} k_6 \quad \left. \vphantom{M_2} \right\} (219)$$

$$M_6 = D_{16} k_1 + D_{26} k_2 + D_{66} k_6$$

where

$$\begin{aligned} D_{11} &= \int Q_{11} z^2 dz, & D_{22} &= \int Q_{22} z^2 dz \\ D_{12} &= \int Q_{12} z^2 dz, & D_{66} &= \int Q_{66} z^2 dz \\ D_{16} &= \int Q_{16} z^2 dz, & D_{26} &= \int Q_{26} z^2 dz \end{aligned} \quad \left. \vphantom{D_{11}} \right\} (220)$$

We have thus derived the moment-curvature relations in Eq. 219 and defined the flexural modulus in Eq. 220.

Now by inverting the moment-curvature relations we can obtain the following relations in terms of flexural compliance, duplicating the same steps used in the inversion of Eq. 138 and 139.

$$\begin{aligned} k_1 &= d_{11} M_1 + d_{12} M_2 + d_{16} M_6 \\ k_2 &= d_{12} M_1 + d_{22} M_2 + d_{26} M_6 \\ k_6 &= d_{16} M_1 + d_{26} M_2 + d_{66} M_6 \end{aligned} \quad \left. \vphantom{k_1} \right\} (221)$$

The relationships above can be presented in matrix multiplication tables as follows:

Table 42. MOMENT-CURVATURE RELATION OF SYMMETRIC LAMINATES IN TERMS OF MODULUS

	$k_1$	$k_2$	$k_6$
$M_1$	$D_{11}$	$D_{12}$	$D_{16}$
$M_2$	$D_{12}$	$D_{22}$	$D_{26}$
$M_6$	$D_{16}$	$D_{26}$	$D_{66}$

Table 43. MOMENT-CURVATURE RELATION OF SYMMETRIC LAMINATES IN TERMS OF COMPLIANCE

	$M_1$	$M_2$	$M_6$
$k_1$	$d_{11}$	$d_{12}$	$d_{16}$
$k_2$	$d_{12}$	$d_{22}$	$d_{26}$
$k_6$	$d_{16}$	$d_{26}$	$d_{66}$

We can now define the effective flexural engineering constants. From the compliance relations in Table 43, we know that under simple bending of  $M_1$  only, the resulting curvature along the 1-axis is:

$$k_1 = d_{11} M_1 \quad (222)$$

The rigidity of this material is:

$$\frac{M_1}{k_1} = \frac{1}{d_{11}} \quad (223)$$

From elementary theory, we know that rigidity of a homogeneous beam is

$$\text{Rigidity} = EI \quad (224)$$

where  $E$  is the homogeneous Young's modulus; and  $I$  is the moment of inertia.

By equating the two relationships, we have:

$$EI = 1/d_{11} \quad (225)$$

or  $E = E_1^f = 1/Id_{11} = 12/h^3 d_{11} \quad (226)$

where for unit width,  $b = 1$ ,  $I = h^3/12$

Similarly, we can show:

$$\left. \begin{aligned} E_2^f &= 12/h^3 d_{22} \\ \nu_{12}^f &= -d_{12}/d_{11} \\ G_{12}^f &= 12/h^3 d_{66} \end{aligned} \right\} \quad (227)$$

The superscript  $f$  denotes effective flexural engineering constants. These are the constants if the beam or plate of our multidirectional laminates is treated like a homogeneous material.

### 3. EVALUATION OF FLEXURAL MODULUS

We will now evaluate the components of flexural modulus by performing the integration of the components in Eq. 220. Similar to the case of in-plane modulus in Section 4, we will first substitute the off-axis modulus of the unidirectional composites using the multiple-angle transformation relations listed in Table 20. The modulus components  $Q_{ij}$  in the integrands of Eq. 220 are the off-axis components except that primes have been deleted. Using the unprimed quantities, we have

$$\text{From Eq. 220} \quad D_{11} = \int Q_{11} z^2 dz$$

$$\text{From Table 20} \quad = \int [U_1 + U_2 \cos 2\theta + U_3 \cos 4\theta] z^2 dz$$

Since  $U_i$  are independent of  $z$  for a laminate with the same composite,

$$D_{11} = U_1 \int z^2 dz + U_2 \int \cos 2\theta z^2 dz + U_3 \int \cos 4\theta z^2 dz \quad (228)$$

$$= U_1 h^{*3} + U_2 V_1 + U_3 V_2 \quad (229)$$

$$\text{where: } h^{*3} = \int_{-h/2}^{h/2} z^2 dz = 2 \int_0^{h/2} z^2 dz = 2 \int_{z_c}^{h/2} z^2 dz = \frac{2}{3} \left[ z^3 \right]_{z_c}^{h/2}$$

$$= \frac{h^3}{12} \left[ \left( 1 - \frac{z_c}{h/2} \right) \right]^3 = \frac{h^3}{12} \left[ 1 - z_c^{*3} \right] \quad (230)$$

$$z_c^* = \text{Volume fraction of core} = 2z_c/h$$

$$\left. \begin{aligned} V_1 &= \int_{-h/2}^{h/2} \cos 2\theta z^2 dz = 2 \int_{z_c}^{h/2} \cos 2\theta z^2 dz \\ V_2 &= 2 \int_{z_c}^{h/2} \cos 4\theta z^2 dz \end{aligned} \right\} \quad (231)$$

It is assumed that the honeycomb core has no stiffness in the 1-2 coordinate system. That is the reason why the lower limit of integration is set at the half depth of the core,  $z_c$ .

Similarly,

$$D_{22} = U_1 h^3 - U_2 V_1 + U_3 V_2 \quad (232)$$

$$D_{12} = U_4 h^3 - U_3 V_2 \quad (233)$$

$$D_{66} = U_5 h^3 - U_3 V_2 \quad (234)$$

$$D_{16} = \frac{1}{2} U_2 V_3 + U_3 V_4 \quad (235)$$

$$D_{26} = \frac{1}{2} U_2 V_3 - U_3 V_4 \quad (236)$$

where

$$\left. \begin{aligned} V_3 &= 2 \int_{z_c}^{h/2} \sin 2\theta z^2 dz \\ V_4 &= 2 \int_{z_c}^{h/2} \sin 4\theta z^2 dz \end{aligned} \right\} \quad (237)$$

Here again, the evaluation of the flexural modulus reduces to the evaluation of the four weighted trigonometric integrals,  $V_1$  to  $V_4$ . Similar to Eq. 170, we can combine the definitions of  $V_i$  into one expression:

$$V_{[1,2,3,4]} = 2 \int_{z_c}^{h/2} [\cos 2\theta, \cos 4\theta, \sin 2\theta, \sin 4\theta] z^2 dz \quad (238)$$

We can also put all the formulas for the components of the flexural modulus into a matrix multiplication table as in Table 44. Note the similarity between this table and the formulas for in-plane modulus in Table 34. The definitions of the  $V_i$ , however, are different.

Table 44. FORMULAS FOR FLEXURAL MODULUS OF SYMMETRIC SANDWICH LAMINATES

	$h^{*3}$	$U_2$	$U_3$
$D_{11}$	$U_1$	$V_1$	$V_2$
$D_{22}$	$U_1$	$-V_1$	$V_2$
$D_{12}$	$U_4$		$-V_2$
$D_{66}$	$U_5$		$-V_2$
$D_{16}$		$V_3/2$	$V_4$
$D_{26}$		$V_3/2$	$-V_4$

where  $h^{*3} = (1 - z_c^{*3}) h^3 / 12$

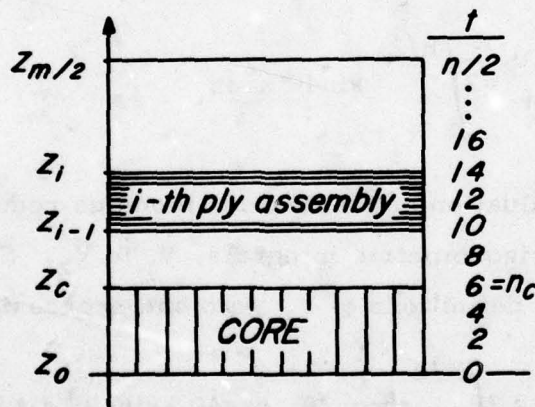

Fig. 64. Schematic diagram of a symmetric sandwich laminate. There are  $m$  ply assemblies and  $n$  plies in the laminate using indices  $i$  and  $t$ , respectively. Assuming the half depth of the core is equal to a multiple of unit plies, the half depth can be designated by  $i = c$  or  $n_c = 6$  in this figure.

Let us try to evaluate the first term in Eq. 238.

$$V_1 = 2 \int_{z_c}^{h/2} \cos 2\theta z^2 dz \quad (239)$$

If we assume that each ply assembly would have the same unidirectional material, the integration in Eq. 239 can be replaced by a summation.

See Fig. 64 for the definitions of indices of summation.

$$V_1 = \frac{2}{3} \sum_{i=c+1}^{m/2} \cos 2\theta_i [z_i^3 - z_{i-1}^3] \quad (240)$$

Simplification of this summation in terms of volume fractions such as that for the in-plane modulus in Eq. 178 is not possible because of the cubic terms here. Some simplification is possible if the half thickness of the core is a multiple of the unit ply thickness; i. e.,

$$n_c = z_c / h_o = \text{an integer} \quad (241)$$

This is assumed in Fig. 64. Then the  $z$  coordinates in Eq. 240 can be replaced by ply numbers as follows:

$$z_c = n_c h_o, z_1 = (n_c + n_1)h_o, z_2 = (n_c + n_1 + n_2)h_o, \dots \quad (242)$$

where  $n_i$  equals the number of plies in the  $i$ -th ply assembly. In terms of Eq. 240, this can be rewritten as

$$V_1 = \frac{2h_o^3}{3} \sum_{i=c+1}^{m/2} \cos 2\theta_i \left[ \left( \frac{z_i}{h_o} \right)^3 - \left( \frac{z_{i-1}}{h_o} \right)^3 \right] \quad (243)$$

Let 
$$V_1^* = \frac{12}{h^3} V_1 \quad (244)$$

Substituting Eq. 243:

$$V_1^* = \frac{8}{n^3} \sum_{i=c+1}^{n/2} \cos 2\theta_i \left[ \left( \frac{z_i}{h_o} \right)^3 - \left( \frac{z_{i-1}}{h_o} \right)^3 \right] \quad (245)$$

where  $n$  equals the total number of plies including the core thickness expressed in equivalent number of plies. The variables in the bracket can be expressed in terms of plies using Eq. 242. The formulas for the other three  $V_i$  will take the same form. Only the trigonometric function changes; i. e.,  $\cos 2\theta_i$  in Eq. 245 is replaced by  $\sin 2\theta_i$  and others.

The bracketed quantity in Eq. 245 is therefore a weighting factor. In the case of the in-plane modulus, the weighting factor was the volume fraction of each ply orientation. We had the rule of mixtures relation. In the case of flexural modulus, this weighting factor put heavier emphasis on the outer plies. Again, if we assume that all plies have the same thickness, and the same core half-depth is a multiple of the unit ply thickness, we can establish the numerical values of this weighting factor starting with the midplane as zero and move upward toward the top surface where  $n/2$ -th ply is located. The evaluation of this weighting factor is listed in Table 45. Eq. 245 can be rewritten as follows:

$$V_1^* = \frac{8}{n^3} \sum_{t=n_c+1}^{n/2} \cos 2\theta_t \left[ t^3 - (t-1)^3 \right] \quad (246)$$

Table 45. NUMERICAL EVALUATION OF WEIGHTING FACTOR FOR THE FLEXURAL MODULUS OF SYMMETRIC SANDWICH LAMINATES

Ply Order Number, t	t	t-1	$t^3 - (t-1)^3$
1	1	0	1
2	2	1	7
3	3	2	19
4	4	3	37
5	5	4	61
6	6	5	91
7	7	6	127
8	8	7	169
9	9	8	217
10	10	9	271
11	11	10	331
12	12	11	397

The index t is used here to distinguish from the index i in Eq. 245. The latter index is intended for the number ply assemblies; and the former index, the total number of all plies. The two indices will be equal if each ply assembly has only one ply.

Using the numerical values listed in Table 45, Eq. 246 can now be written as:

$$V_1^* = \frac{8}{3} \left[ \cos 2\theta_1 + 7\cos 2\theta_2 + 18\cos 2\theta_3 + 37\cos 2\theta_4 + \dots \right] \quad (247)$$

If adjacent plies have the same ply orientation, we have for example, ply assemblies with two plies each,

$$\theta_1 = \theta_2, \theta_3 = \theta_4, \dots$$

Then 
$$V_1^* = \frac{8}{3} \left[ 8\cos 2\theta_1 + 56\cos 2\theta_3 + 152\cos 2\theta_5 + \dots \right] \quad (248)$$

If we have a honeycomb core with a half-depth of 4-ply thickness, or

$$z_c = 4h_o \quad (249)$$

the first ply or ply assembly for the facing will start with  $t = 5$  in Table 45.

$$V_1^* = \frac{8}{3} \left[ 61\cos 2\theta_1 + 91\cos 2\theta_2 + 127\cos 2\theta_3 + 169\cos 2\theta_4 + \dots \right] \quad (250)$$

where the total number of plies  $n$  must include the half-depth of the core which is equal to 4 plies. If we have a 3-ply facing, the value of  $n/2$  is 7.

#### 4. FLEXURAL BEHAVIOR OF UNIDIRECTIONAL LAMINATES

If our laminate is unidirectional, the ply orientation  $\theta$  is a fixed value, independent of the  $z$  coordinate. The trigonometric functions in Eq. 238 can be taken outside of the integrals. The resulting  $V_i$  are:

$$V_{[1,2,3,4]} = [\cos 2\theta, \cos 4\theta, \sin 2\theta, \sin 4\theta] h^{*3} \quad (251)$$

where  $h^{*3}$  is defined in Eq. 230. For this simplified case, the formulas for the flexural modulus in place of Table 44 can be restructured as follows:

Table 46. FORMULAS FOR THE FLEXURAL MODULUS OF UNIDIRECTIONAL COMPOSITES

	$U_1$	$U_2$	$U_3$
$D_{11}^*$	$U_1$	$\cos 2\theta$	$\cos 4\theta$
$D_{22}^*$	$U_1$	$-\cos 2\theta$	$\cos 4\theta$
$D_{12}^*$	$U_4$		$-\cos 4\theta$
$D_{66}^*$	$U_5$		$-\cos 4\theta$
$D_{16}^*$		$\frac{1}{2} \sin 2\theta$	$\sin 4\theta$
$D_{26}^*$		$\frac{1}{2} \sin 2\theta$	$-\sin 4\theta$

$$\text{where } D_{ij}^* = \frac{12}{h^3 [1 - z_c^{*3}]} D_{ij} = D_{ij} / h^{*3}$$

Note that the constants in this table are identical to those of the transformed in-plane modulus of unidirectional composites in Table 20. The only difference is the normalizing factor needed for the flexural modulus. The  $h^{*3}$  factor is defined in Eq. 230. Thus, we can obtain the off-axis flexural modulus by multiplying the off-axis  $Q_{ij}$  by this factor. The transformed flexural modulus will have exactly the same as the transformed in-plane modulus in Fig. 35. This is shown in Fig. 65. All the remarks about the transformed in-plane modulus following Fig. 35 are equally applicable to the flexural modulus.

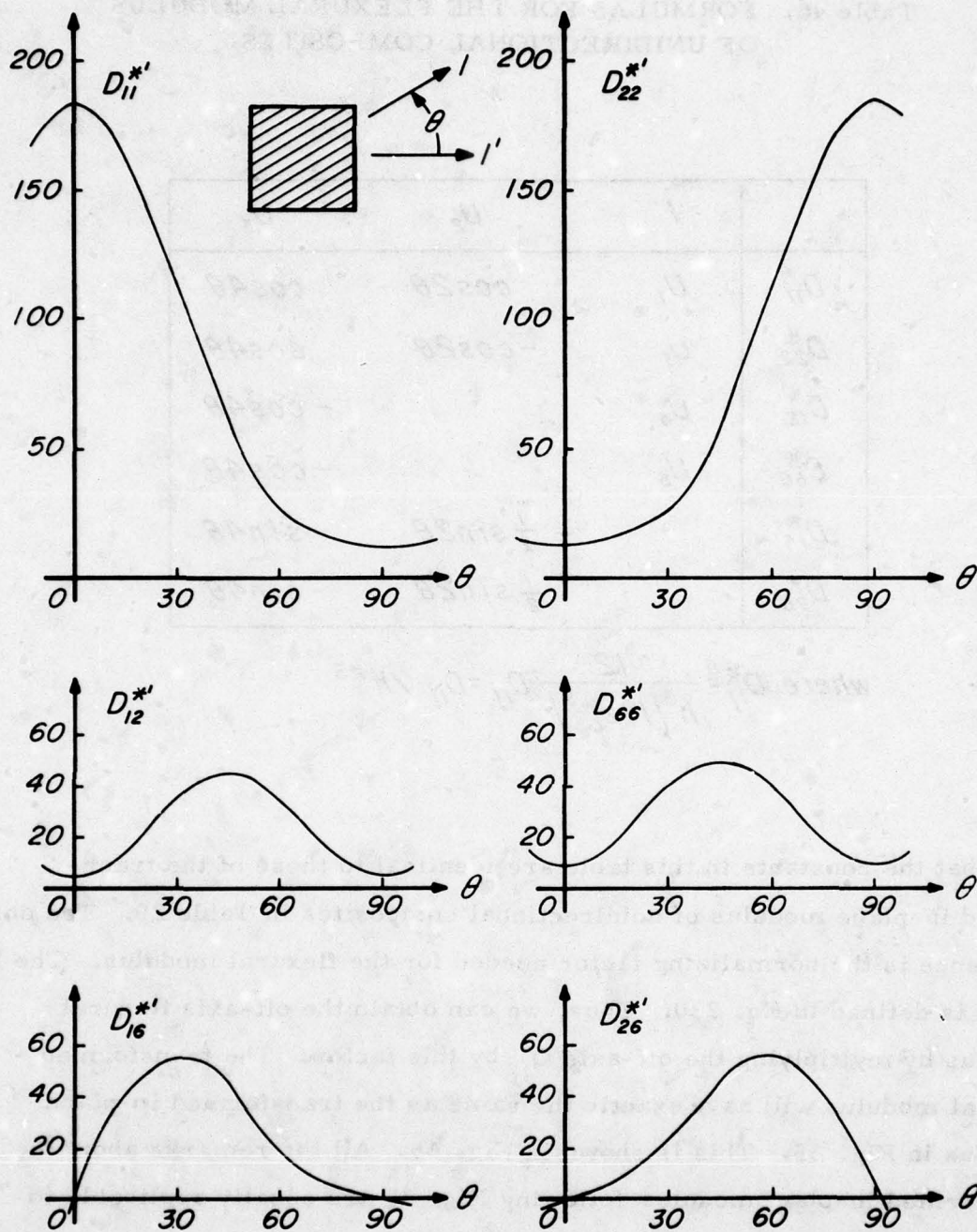

Fig. 65. Transformed flexural modulus of unidirectional T300/5208. These are the same curves as those in Fig. 35 with the exception of the normalizing factor in Table 46. The normalized modulus are defined:  $D_{ij}^* = D_{ij} / h^{*3}$ , where  $h^*$  is defined in Eq. 230.

By comparing Tables 46 and 20, we have:

$$D'_{11} = \frac{h^3 \left[ \frac{1-z^*}{c} \right]^3}{12} Q'_{11} = \frac{h^{*3}}{12} Q_{11}' \quad (252)$$

Identical factor shall be applied to the other components of the flexural modulus  $D_{ij}$ .

From this simple relation in Eq. 252, we can immediately write down the flexural compliance  $S_{ij}$  divided by the normalizing factor. We have now:

$$d'_{11} = \frac{12}{h^3 \left[ \frac{1-z^*}{c} \right]^3} S'_{11} = \frac{12}{h^{*3}} S_{11}' \quad (253)$$

where the transformed in-plane compliance  $S'_{ij}$  can be found from Table 29. and Fig. 41. The latter is repeated in Fig. 65 where the normalizing factor has been added. Thus, the off-axis flexural compliance is the same as that of the in-plane compliance with the exception of the  $h^{*3}$  factor. So long as a beam and plate consist of symmetric, homogeneous factings, their flexural modulus and compliance can be obtained directly from the in-plane modulus and compliance, respectively. We only need to know the values of the normalizing factor, as shown in Eq. 252 and 253. The flexural rigidity of unidirectional composites is, therefore, as simple to calculate as that of ordinary materials.

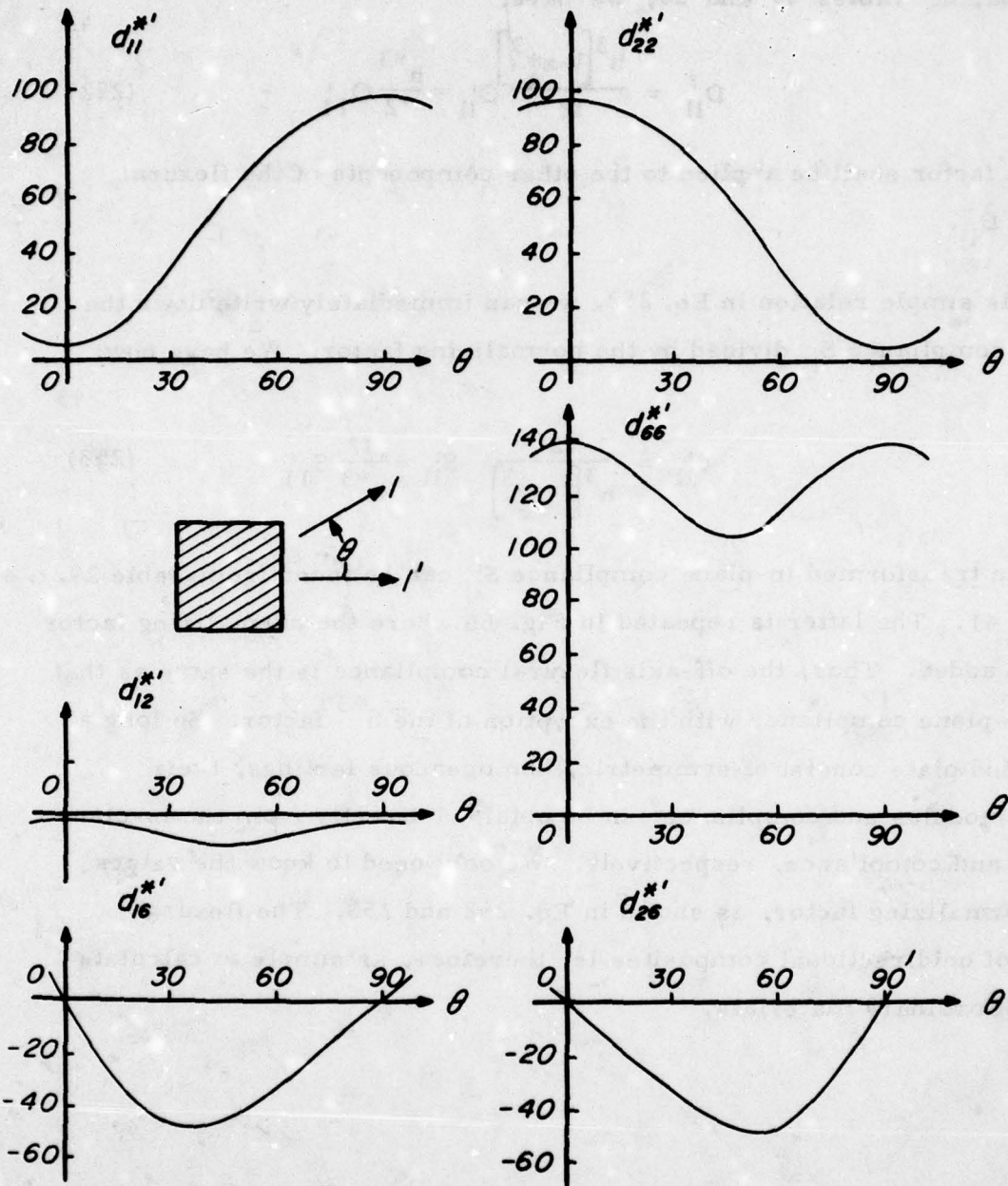

Fig. 66. Transformed flexural compliance of unidirectional T300/5208. This is the same as Fig. 41 for the off-axis compliance except the normalizing factor  $h^{*3}$  has been added.

As we have defined the flexural rigidity in Eq. 223 et al, we know that a symmetric sandwich beam with unidirectional facings will have the following rigidity:

$$(EI)_1 = \frac{I}{d'_{11}} = \frac{h^3 \left[ 1 - z_c^{*3} \right]}{12} \frac{b}{S'_{11}} \quad (254)$$

where  $(EI)_1$  = bending rigidity of a beam cut along the 1-axis of our laminate

$b$  = width of beam

We can make the following remarks about the flexural rigidity of beams and plates relying on the expressions in Eq. 252 and 253, respectively:

- Rigidity is highly dependent on the thickness  $h$ . If we double the thickness, we will get a cubic increase in return, or 8 times the rigidity.
- Removal of materials near the midplane is a very effective way of reducing the weight without much sacrifice in the rigidity. If one-third of the material at the center is removed; i. e.,  $z_c^* = 1/3$ , the loss in rigidity as measured by  $z_c^{*3}$  is only 1/27 of the solid beam or plate.

Both remarks are valid for a composite and ordinary materials so long as the facing material is homogeneous. If multidirectional composites are used for the facing, the remarks above are only true qualitatively. We will discuss this later in this section.

For an off-axis unidirectional composite facing, the beam will twist under pure bending. This is the equivalent of the shear coupling in the in-plane behavior of off-axis materials. The nonzero shear coupling components  $Q_{16}$  and  $Q_{26}$  will result in nonzero  $D_{16}$ ,  $D_{26}$ ,  $d_{16}$ , and  $d_{26}$ . From Table 43, we can relate the induced curvatures by bending moments. For example, if we apply bending  $M_1$  to our off-axis beam as shown in Fig. 67,

from Table 43:

$$\left. \begin{aligned} k_1 &= d_{11} M_1 \\ k_2 &= d_{12} M_1 \\ k_6 &= d_{16} M_1 \end{aligned} \right\} \quad (255)$$

The first curvature is due to normal bending; the second, the Poisson's coupling; and the third, the twisting coupling. The question now is how will the twist occur: how much, and in what direction. This is the recurring question associated with shear stress and shear strain. Again, we must pay attention to the sign convention.

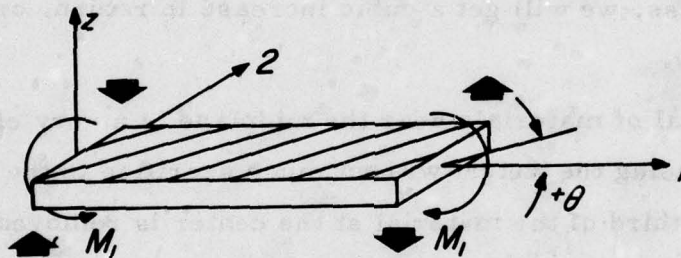

Fig. 67. Pure bending of an off-axis beam. Positive ply orientation and positive moment are shown. Heavy arrows show the direction of movements of the four corners, similar to Fig. 60(c).

We know from Fig. 66 that the shear coupling terms for T300/5208 and for most practical composites are negative for positive ply angles. Since the moment in Fig. 67 is also positive, we know from Eq. 255 that the twisting curvature must be negative. Now refer to Fig. 60(c) where we showed the effect of a positive twisting moment on the stress distribution and the possible directions of displacements indicated by heavy arrows. Hence a positive curvature will be a clockwise rotation about the 1-axis. For our beam in Fig. 67, we have negative curvature. Therefore, the twisting curvature caused by the bending moment will be a counterclockwise rotation along the 1-axis. This rotation is represented by the heavy arrows shown at the corners.

## 5. FLEXURAL MODULUS OF CROSS-PLY LAMINATES

Cross-ply laminates are the simplest multidirectional laminates.

Repeating the values of the trigonometric functions in Table 36, we have the following:

Table 47. VALUES OF TRIGONOMETRIC FUNCTIONS FOR CROSS-PLY LAMINATES

$\theta_i$	$\cos 2\theta_i$	$\cos 4\theta_i$	$\sin 2\theta_i$	$\sin 4\theta_i$
0	1	1	0	0
90	-1	1	0	0

Let us study the effect of stacking sequence on the flexural modulus of symmetric laminates. We will use a 16-ply laminate with three different stacking sequences as shown in Fig. 68.

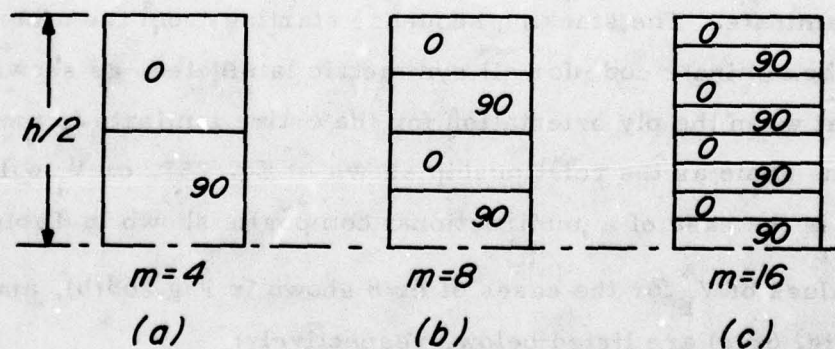

Fig. 68. Cross-ply laminates with 16 plies but different number of ply assemblies; viz.,  $m=4$ , 8 and 16.

From the second column of Table 47, we know that

$$\cos 4\theta_1 = \cos 4\theta_2 = 1 \quad (256)$$

Following the pattern of Eq. 247 for  $V_1^*$ , we can immediately write down the analogous relation for  $V_2^*$ .

$$V_2^* = \frac{8}{n} (1 + 7 + 19 + 37 + 61 + 91 + 127 + 169) = \frac{512}{512} = 1 \quad (257)$$

where  $n = 16$  was used. Because of the special relation in Eq. 256, the  $V_2^*$  will remain constant, independent of the stacking sequences shown in Fig. 68.

Knowing the values of  $\cos 2\theta_i$  from the first column of Table 47, we can substitute the values into Eq. 247 for the case of  $m=4$  or Fig. 68(a).

$$V_1^* = \frac{1}{512} (-1 - 7 - 19 - 37 + 61 + 91 + 127 + 169) = \frac{394}{512} = \frac{3}{4} \quad (258)$$

Note that the first ply from the midplane upward is a 90-degree ply. We have mentioned before that there is a difference between the laminate code as defined by Eq. 207 which follows an ascending order from the bottom surface of the laminate. The stacking sequence starting from the midplane is the opposite of the laminate code for all symmetric laminates, as shown in Fig. 68. Note also that when the ply orientation for the entire laminate is the same,  $V_1^*$  will be the same as the relationship shown in Eq. 257, or  $V_1^*$  will be unity. This is the case of a unidirectional composite shown in Table 46.

The values of  $V_1^*$  for the cases of  $m=8$  shown in Fig. 68(b), and that of  $m=16$  in Fig. 68(c) are listed below, respectively:

For  $m=8$

$$V_1^* = \frac{1}{512} (-1 - 7 + 19 + 37 - 61 - 91 + 127 + 169) = \frac{192}{512} = \frac{3}{8} \quad (259)$$

For  $m=16$ ,

$$V_1^* = \frac{1}{512} (-1 + 7 - 19 + 37 - 61 + 91 - 127 + 169) = \frac{96}{512} = \frac{3}{16} \quad (260)$$

It appears that a pattern has been established that for cross-ply symmetric laminates with increase ply assemblies as shown in Fig. 68.

$$V_1^* = \frac{3}{m}, \quad m = 4, 6, 12, \dots \quad (261)$$

where  $m$  = total number of ply assemblies. As  $m$  increases,  $V_1^*$  approaches zero; i. e., the cross-ply laminate becomes square-symmetric, or  $D_{11} = D_{22}$ .

Summarizing the results for this family of cross-ply laminates in which the total number of ply assemblies is a variable, we can enter the values of  $V_i$  into Table 44 and arrive at Table 48. Care must be exercised in the proper use of normalizing factors.

Table 48. FORMULAS FOR FLEXURAL MODULUS OF A SOLID SYMMETRIC [0/90] CROSS-PLY LAMINATE

	$U_1$	$U_2$	$U_3$
$D_{11}^*$	$U_1$	$3/m$	$1$
$D_{22}^*$	$U_1$	$-3/m$	$1$
$D_{12}^*$	$U_4$		$-1$
$D_{66}^*$	$U_5$		$-1$

$$D_{16} = D_{26} = 0$$

$$D_{ij}^* = 12 D_{ij} / h^3, \quad z^* = 0$$

Note that only  $V_1^*$  is affected by the stacking sequence. We only showed the case of changing the number of ply assemblies. Other stacking sequences than those shown in Fig. 68 are, of course, possible; an example of which may be  $[0_2/90_4/0_2]_S$ . The value for  $V_1$  will be different from that shown in Eq. 258 and Table 48. The effect of  $V_1$  on the flexural modulus is the degree of anisotropy, or the difference between  $D_{11}$  and  $D_{22}$ . In the limit when we have infinite numbers of alternating plies, our laminate will become quasi-homogeneous. The property of the laminate will be square symmetric, not isotropic. This difference between square symmetric and isotropy was illustrated in Eq. 22 and 23.

Let us calculate the flexural modulus of cross-ply laminates as shown in Fig. 68. The formulas for this class of special laminates are listed in Table 48. Using the data for T300/5208, we have for 16-ply laminates with no core, or  $z_c = 0$ .

$$h = 16h_0 = 16 \times 125 \times 10^{-6} = 2 \times 10^{-3} \text{ m}$$

$$D_{11} = \frac{h^3}{12} [U_1 + 3U_2/m + U_3] \quad (262)$$

$$= 666 \times 10^{-12} [76.37 + 3 \times 85.73/m + 19.71]$$

$$= 666 \times 10^{-12} \times 160.3 \times 10^9$$

$$= 106.8 \text{ Nm for 4-ply assembly laminate or } m=4$$

or	= 85.4 Nm	" 8 "	" "	" "	" "	m=8	}	(263)
	= 74.7 Nm	" 16 "	" "	" "	" "	m=16		
or	= 64.0 Nm	for quasi-homogeneous laminate or $m=\infty$						

Similarly,

$$D_{22} = \frac{h^3}{12} \left[ U_1 - 3U_2/m + U_3 \right] \quad (264)$$

	= 21.16 Nm	for 4-ply assembly laminate or	m=4	}	(265)
or	= 42.58 Nm	" 8 " " " "	m=8		
or	= 53.28 Nm	" 16 " " " "	m=16		
or	= 63.99 Nm	" quasi-homogeneous laminate			

Components of  $D_{12}$  and  $D_{66}$  are not dependent on  $V_1$  or  $m$ , the number of ply assemblies. So their constant values are 1.93 and 4.77 Nm, respectively.

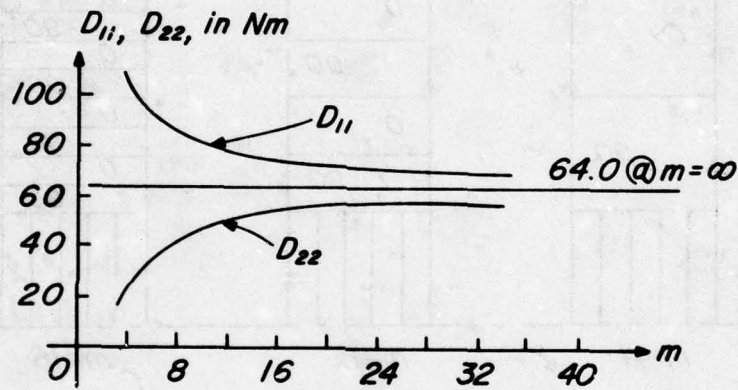

Fig. 69. Flexural modulus components as functions of ply assemblies for a T300/5208 laminate. Note that as ply assemblies  $m$  increases, the modulus components approach the modulus of the quasi-homogeneous laminate, although many assemblies are needed for good convergence.

Fig. 69 shows the sensitivity of the two normal components of the flexural modulus of T300/5208 as functions of the number of ply assemblies. The convergence for this case does not appear to be very rapid.

If we introduce a honeycomb core into our cross-ply laminate, we want to show how the flexural modulus can be calculated. Let us examine three cross-ply laminates in Fig. 70. These laminates are sandwich constructions with facing materials identical to those solid laminates shown in Fig. 68. The number of ply assemblies are different among these laminates. The core-half-depth is equal to four plies.

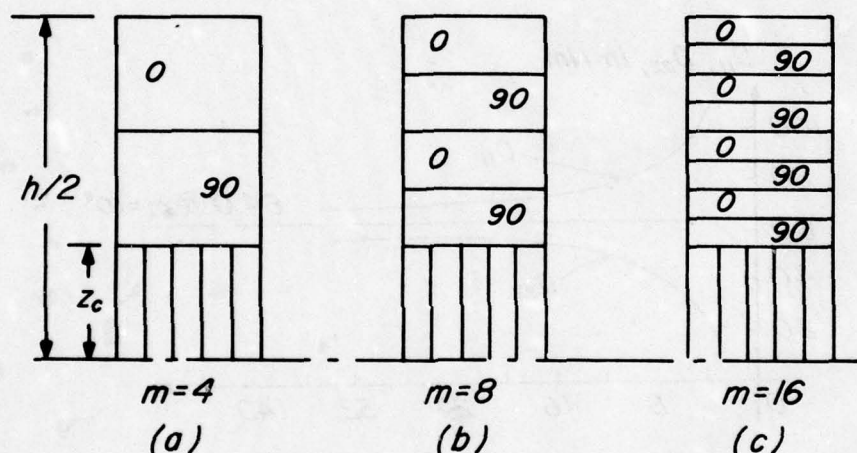

Fig. 70. Cross-ply sandwich laminates. This symmetric laminate has 2-8 ply facings and 4-ply thick half-depth of core. Total thickness of laminate is 24 equivalent plies. Three different numbers of ply assemblies are shown;  $m=4$ , 8 and 16. This figure shows the same facing laminates as those solid laminates in Fig. 68.

AD-A067 544

AIR FORCE MATERIALS LAB WRIGHT-PATTERSON AFB OHIO  
INTRODUCTION TO COMPOSITE MATERIALS. VOLUME I. DEFORMATION OF U--ETC(U)  
JAN 79 S W TSAI, H T HAHN  
AFML-TR-78-201-VOL-1

F/G 11/4

UNCLASSIFIED

NL

3 OF 3  
ADA  
067544



END  
DATE  
FILMED

8-79  
DDC

The flexural modulus of these sandwich laminates can be readily calculated by substituting the nonzero trigonometric functions into Eq. 251.

For the case of 2-ply assembly laminate in Fig. 70(a), or  $m = 4$ .

$$V_1^* = \frac{8}{24^3} (-61 - 91 - 127 - 169 + 217 + 271 + 331 + 397) = \frac{4}{9} \quad (266)$$

or for  $m=8$

$$V_1^* = \frac{8}{24^3} (-61 - 91 + 127 + 169 - 217 - 271 + 331 + 397) = \frac{2}{9} \quad (267)$$

or for  $m = 16$

$$V_1^* = \frac{8}{24^3} (-61 + 91 - 127 + 169 - 217 + 271 - 331 + 397) = \frac{1}{9} \quad (268)$$

We notice the trend again as the number of ply assemblies  $m$  increase, the value of  $V_1^*$  decreases by the following relation:

$$V_1^* = \frac{16}{9m} \quad (269)$$

The sandwich laminates approaches square-symmetric as  $m$  increases.

We need the following values before we can use the formulas for the flexural modulus in Table 44.

$$\begin{aligned} V_2^* &= \frac{8}{24^3} (61 + 91 + 127 + 169 + 217 + 271 + 331 + 393) = \frac{1664}{1728} \\ &= \frac{26}{27} \end{aligned} \quad (270)$$

$$z_c^* = 1/3 \quad (271)$$

$$1 - z_c^{*3} = \frac{26}{27} \quad (272)$$

Note this is the same as that in Eq. 270. This is expected for homogeneous material shown in Table 46. The same correction factor for the sandwich core is applied to the first column of Table 44. Summarizing the results in Eq. 269 to 272, we can show the formulas for the sandwich laminates in Fig. 70 in a matrix multiplication table as follows:

Table 49. FORMULAS FOR FLEXURAL MODULUS OF A SYMMETRIC SANDWICH LAMINATE WITH [0/90] FACINGS

	$\frac{26}{27}$	$U_2$	$\frac{26}{27} U_3$
$D_{11}^*$	$U_1$	$16/9m$	$1$
$D_{22}^*$	$U_1$	$-16/9m$	$1$
$D_{12}^*$	$U_4$		$-1$
$D_{66}^*$	$U_5$		$-1$

$$D_{16} = D_{26} = 0$$

$$D_{ij}^* = 12 D_{ij} / h^3$$

We are now ready to calculate the flexural modulus of our sandwich laminates assuming the facing material is T300/5208.

$$h = 24h_o = 24 \times 125 \times 10^{-6} = 3 \times 10^{-3} \text{ m}$$

$$z_c = 4h_o = .5 \times 10^{-3} \text{ m}$$

(273)

From Table 43 and Table 49 for  $m=4$  in Fig. 67(a):

$$\begin{aligned}
 D_{11} &= \frac{h^3}{12} \left[ 26U_1/27 + 16U_2/9m + 26U_3/27 \right] \\
 &= 2.25 \times 10^{-9} \left[ 26 \times 76.37/27 + 16 \times 85.73/9 \times 4 + 26 \times 19.71/27 \right] \\
 &= 2.25 \times 10^{-9} \times 130.6 \times 10^9 \\
 &= 293.9 \text{ Nm}
 \end{aligned} \tag{274}$$

or for  $m=8$ ,

$$D_{11} = 2.25 \times 10^{-9} \times 111.5 \times 10^9 = 251.9 \text{ Nm} \tag{275}$$

or for  $m=16$ ,

$$D_{11} = 2.25 \times 10^{-9} \times 102.0 \times 10^9 = 229.6 \text{ Nm} \tag{276}$$

or for  $m=\infty$ ,

$$D_{11} = 2.25 \times 10^{-9} \times 92.52 \times 10^9 = 209.1 \text{ Nm} \tag{277}$$

Similarly, from Table 49:

$$D_{22} = \frac{h^3}{12} \left[ 26U_1/27 - 16U_2/9m + 26U_3/27 \right] \tag{278}$$

For  $m=4$   $D_{22} = 2.25 \times 10^{-9} \times 54.51 \times 10^9 = 122.4 \text{ Nm}$

or for  $m=8$   $D_{22} = 2.25 \times 10^{-9} \times 73.47 \times 10^9 = 165.3 \text{ Nm}$

or for  $m=16$   $D_{22} = 2.25 \times 10^{-9} \times 83.00 \times 10^9 = 186.8 \text{ Nm}$

or for  $m=\infty$   $D_{22} = 2.25 \times 10^{-9} \times 92.52 \times 10^9 = 208.1 \text{ Nm}$

} (279)

This last value is the modulus for a quasi-homogeneous laminate. This is the same value to which  $D_{11}$  will also converge. Thus, we will have a square-symmetric laminate in flexure. The results of these components of the flexural modulus will be plotted in Fig. 71.

Note the substantial increase in the modulus components of the sandwich construction here over the solid laminates shown in Fig. 69. First of all, there is a thickness increase from 16 to 24 plies. If our laminate were homogeneous and solid or without a core, the increase in the flexural modulus components will be the cube of the thickness ratio. In our particular case, it will be:

$$(24/16)^3 = 3.375 \quad (280)$$

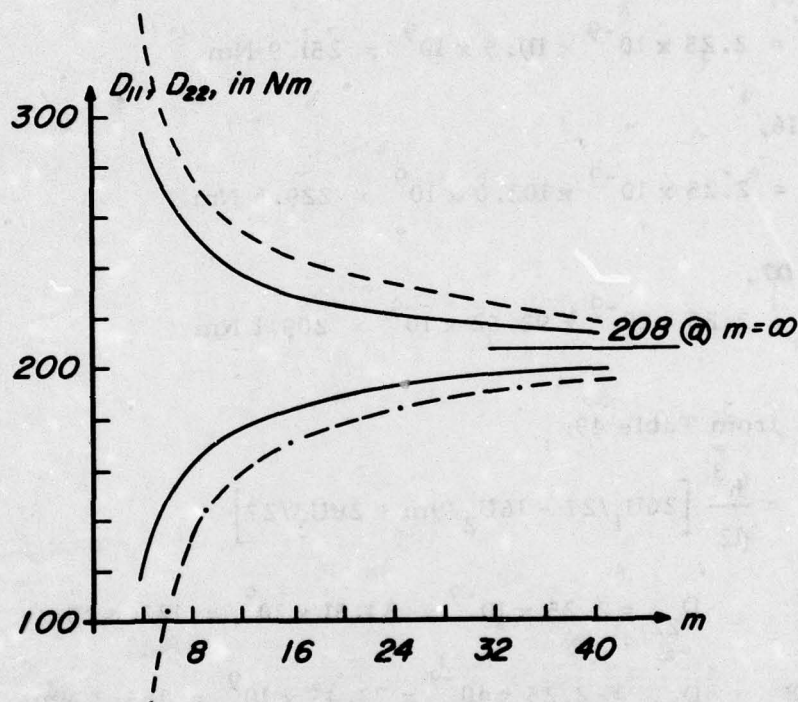

Fig. 71. Flexural modulus for a sandwich laminate of T300/5208 as functions of the number of ply assemblies. The trend is very similar to that shown in Fig. 69 for solid laminates. The dashed lines are bound on the modulus in Fig. 69 corrected for thickness and core depth. Note the approach by direct correction, although valid for homogeneous facing materials, is not so for discrete laminates. Calculation for specific stacking sequence of the facing is necessary.

On the other hand, if we have a sandwich construction, there should be a reduction proportional to

$$1 - z_c^*{}^3 \quad (281)$$

which represents the effect of core if the facings were homogeneous. Assuming the core thickness for our laminate is the same as those in Fig. 70, the value of the core correction in Eq. 281 will be 26/27 as in Eq. 272. Thus, the net effect of thickness increases and the presence of core is simply the product of Eq. 280 and 281:

$$3.375 \times 26/27 = 3.25 \quad (282)$$

This factor is applied to the curves in Fig. 69; i. e., the flexural modulus for each value of  $m$  is increased by 3.25 because the thickness is increased. The results are shown as dashed lines in Fig. 71. Note the difference between the dashed and solid lines. The point is that the flexural modulus of multidirectional laminates must be calculated for each stacking sequence and core depth. Simple ratios such as that in Eq. 282 are applicable only to sandwich construction with homogeneous facing material. Eq. 252 for example, provide the ratios for thickness and core depth corrections. But this is limited to unidirectional material only. Laminated composites must be assessed on individual basis. Attempts to simplify the calculation of flexural modulus by smearing the laminated facing can lead to erroneous results. Since precise calculation is straight forward, such shortcuts are not warranted.

## 6. FLEXURAL MODULUS OF SYMMETRIC LAMINATES

In the last section we saw that cross-ply laminates are orthotropic, or square symmetric when the number of ply assemblies approach infinity. We will see in this section that symmetric laminates with or without core are generally anisotropic. Balanced laminates such as an angle-ply laminate are orthotropic in their in-plane modulus but are generally anisotropic in their

flexural modulus. The reason for this is the fact that the position of each ply is unique. Each ply occupies unique values along the z-axis. The shear coupling terms  $Q_{16}$  and  $Q_{26}$  of a  $+\theta$  ply cannot be cancelled by those of a  $-\theta$  ply unless the positions of these plies are judiciously selected. We will show later that the shear coupling terms can be cancelled if antisymmetric laminates are used. So there are two methods of obtaining orthotropic flexural modulus:

- Use of on-axis plies only. This is the case of cross-ply laminates.
- Use of antisymmetric laminates. This will be discussed later.

The motivation to make laminates orthotropic (and symmetric) is often driven by the availability of the in-plane stress analysis and flexural analysis of laminates. Most current analytical tools are limited to orthotropic and homogeneous plates. It seems ridiculous to limit the use of composite materials by the availability of analytical tools. Although it is not within the scope of the introductory text to cover the stress analysis of anisotropic bodies, it is important to understand how anisotropy, and nonhomogeneity emerge in composite laminates and to what degree they can be manipulated. To rule out anisotropy, for example, forces us to impose arbitrary limits on the use of composite materials. In this case, composite materials demand more advanced analytical tools than ordinary materials. In many finite-element techniques, these features are, or can be, incorporated. But much more progress is needed before we can feel comfortable with anisotropy.

## 7. PLY STRESS AND PLY STRAIN ANALYSIS

The ply stress and ply strain in a symmetric laminate with or without core due to flexure can be determined following the procedure in Section IV for the in-plane stretching. This is shown in Fig. 72 which is analogous to Fig. 50 for the in-plane behavior.

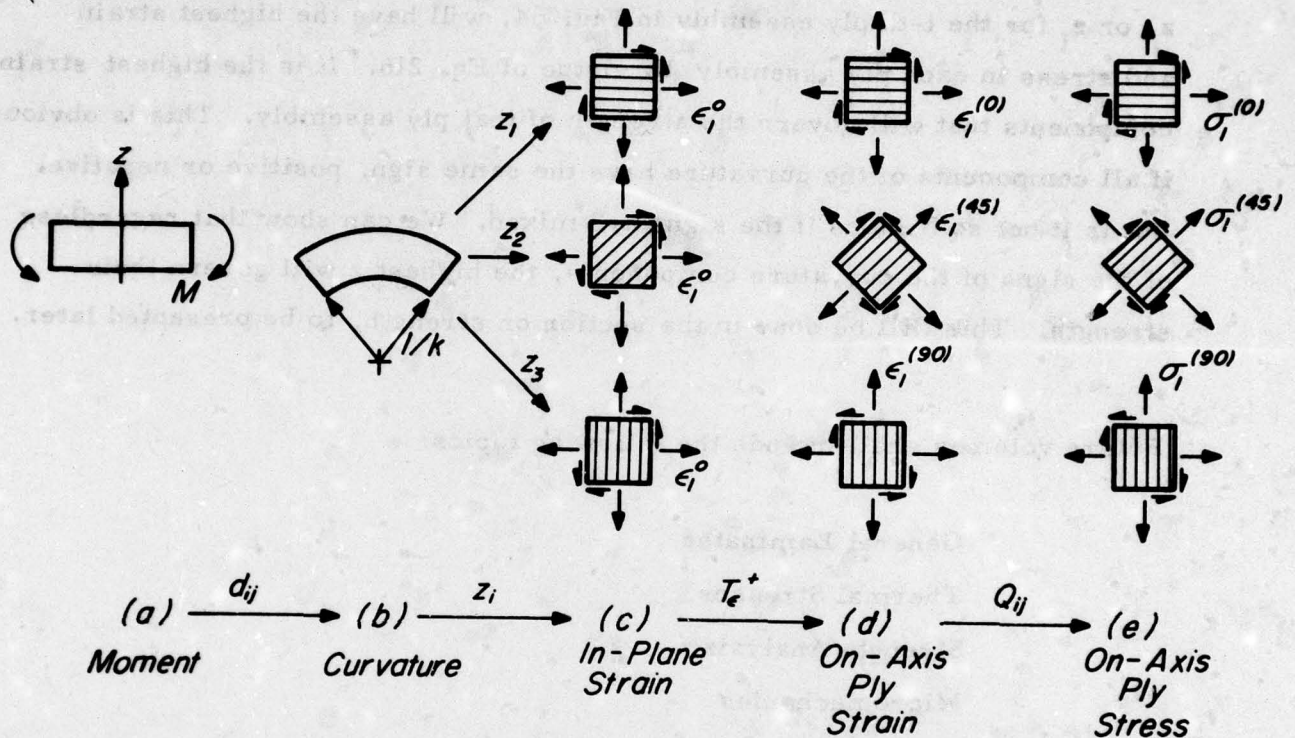

Fig. 72. Ply stress and strain in a symmetric laminate under flexure:

From (a) to (b): Use moment-curvature relations in Table 42.

From (b) to (c): Use curvature-strain equation in Eq. 216.

Use top surface of each ply assembly for the  $z$ -value; i. e.,  $z_i$  for the  $i$ -th ply assembly shown in Fig. 64.

From (c) to (d): Use strain transformation to transform the laminate strain to the on-axis strain on the top surface of each ply assembly.

From (d) to (e): Use the on-axis stress-strain relation to determine the corresponding on-axis ply stress.

The process of determining the ply stress and ply strain is straight forward. The motivation is to assess the strength of each ply within the laminate. The strength calculation in terms of strength ratios will be covered in a later section. We have shown in Fig. 72 that the highest value of  $z$  be used for the ply strain determination as we go from (b) to (c). The highest  $z$ , or  $z_i$  for the  $i$ -th ply assembly in Fig. 64, will have the highest strain and stress in each ply assembly by virtue of Eq. 216. It is the highest strain components that will govern the strength of that ply assembly. This is obvious if all components of the curvature have the same sign, positive or negative. But is it not so obvious if the signs are mixed. We can show that regardless of the signs of the curvature components, the highest  $z$  will govern their strength. This will be done in the section on strength, to be presented later.

Future volumes shall include the following topics:

General Laminates

Thermal Stresses

Strength Analysis

Micromechanics

Fracture

Fatigue