

AD-A067 713

IBM FEDERAL SYSTEMS DIV OWEGO N Y
ELECTRICAL CHARACTERIZATION OF 16K DYNAMIC RAMS. (U)

F/G 9/2

UNCLASSIFIED

FEB 79 F D AUSTIN, J R FLORINI, E L HUNTER
RADC-TR-79-5

F30602-77-C-0222
NL

1 OF 2
ADA
067713



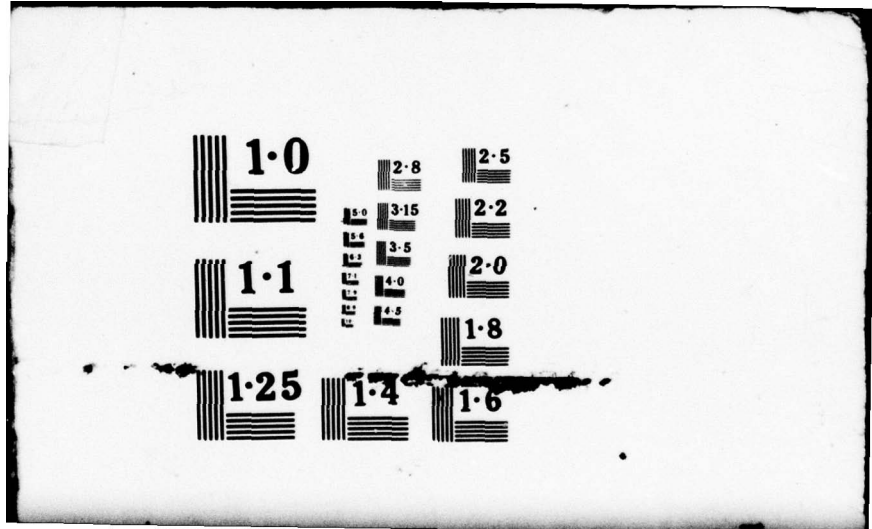

1.0

2.8

2.5

3.0

3.15

2.2

3.5

4.0

2.0

4.5

1.8

1.1

1.25

1.4

1.6

AD A06713

DDC FILE COPY

LEVEL II



RADC-TR-79-5
Final Technical Report
February 1979

ELECTRICAL CHARACTERIZATION OF 16K DYNAMIC RAMs

IBM

F. D. Austin
J. R. Florini
E. L. Hunter
F. A. Nezelek

APPROVED FOR PUBLIC RELEASE; DISTRIBUTION UNLIMITED

ROME AIR DEVELOPMENT CENTER
Air Force Systems Command
Griffiss Air Force Base, New York 13441

DDC
RECEIVED
APR 23 1979
REGULATED

79 04 20 001

This report has been reviewed by the RADC Information Office (OI) and is releasable to the National Technical Information Service (NTIS). At NTIS it will be releasable to the general public, including foreign nations.

RADC-TR-79-5 has been reviewed and is approved for publication.

APPROVED:

Regis C. Hilow

REGIS C. HILLOW
Project Engineer

APPROVED:

Josef J. Naresky

JOSEF J. NARESKEY
Chief, Reliability and Compatibility Division

FOR THE COMMANDER:

John P. Huss

JOHN P. HUSS
Acting Chief, Plans Office

If your address has changed or if you wish to be removed from the RADC mailing list, or if the addressee is no longer employed by your organization, please notify RADC (RHSO) Griffice AFB TX 13441. This will assist us in maintaining a current mailing list.

Do not return this copy. Retain or destroy.

UNCLASSIFIED

SECURITY CLASSIFICATION OF THIS PAGE (When Data Entered)

| 19 REPORT DOCUMENTATION PAGE | | READ INSTRUCTIONS BEFORE COMPLETING FORM | |
|---|--|---|-------------------------------|
| 18 | 1. REPORT NUMBER RADC TR-79-5 | 2. GOVT ACCESSION NO. | 3. RECIPIENT'S CATALOG NUMBER |
| 6 | 4. TITLE (and Subtitle) ELECTRICAL CHARACTERIZATION OF 16K DYNAMIC RAMs | 5. TYPE OF REPORT & PERIOD COVERED Final Technical Report | 9 |
| 10 | 7. AUTHOR(s) F. D. Austin, E. L. Hunter J. R. Florini, F. A. Nezelek | 8. CONTRACT OR GRANT NUMBER(s) F30602-77-C-0222 | 15 |
| | 9. PERFORMING ORGANIZATION NAME AND ADDRESS IBM Corporation Federal Systems Division Owego NY 13827 | 10. PROGRAM ELEMENT, PROJECT, TASK AREA & WORK UNIT NUMBERS 62702F 23380139 | 12 139p |
| | 11. CONTROLLING OFFICE NAME AND ADDRESS Rome Air Development Center (RBRM) Griffiss AFB NY 13441 | 12. REPORT DATE Feb 79 | 11 |
| | 14. MONITORING AGENCY NAME & ADDRESS (if different from Controlling Office) Same | 13. NUMBER OF PAGES 131 | 17 01 |
| | | 15. SECURITY CLASS. (of this report) UNCLASSIFIED | |
| | | 15a. DECLASSIFICATION/DOWNGRADING SCHEDULE N/A | |
| 16. DISTRIBUTION STATEMENT (of this Report) Approved for public release; distribution unlimited. | | | |
| 17. DISTRIBUTION STATEMENT (of the abstract entered in Block 20, if different from Report) Same | | | |
| 18. SUPPLEMENTARY NOTES RADC Project Engineer: Regis C. Hilow (RBRM) | | | |
| 19. KEY WORDS (Continue on reverse side if necessary and identify by block number) Memory, Dynamic RAM, Random Access Memory, Monolithic, Semiconductor, MOS, Testing, Characterization, Electrical Performance, Case Temperature | | | |
| 20. ABSTRACT (Continue on reverse side if necessary and identify by block number) Electrical characterizations were performed on 16K dynamic RAMs available from the merchant semiconductor industry. Based on the data obtained, parameter limits were established and proposed for a draft 38510 specification. The data, proposed limits, and related discussion are presented. | | | |

DD FORM 1 JAN 73 1473 EDITION OF 1 NOV 65 IS OBSOLETE

UNCLASSIFIED 409206
SECURITY CLASSIFICATION OF THIS PAGE (When Data Entered)

79 04 20 001

| | | |
|--------------------------------|----------------------|-------------------------------------|
| DTIC | Write Section | <input checked="" type="checkbox"/> |
| DDC | Diff Section | <input type="checkbox"/> |
| UNANNOUNCED | | |
| JUSTIFICATION | | |
| BY | | |
| DISTRIBUTION/AVAILABILITY CODE | | |
| Dist. | AVAIL and/or SPECIAL | |
| A | | |

TABLE OF CONTENTS

1.0 INTRODUCTION 1

2.0 OBJECTIVES OF THE PROJECT 2

3.0 CONCLUSIONS 2

4.0 PROFILE OF A 16K DYNAMIC RAM 4

5.0 CHARACTERIZATION APPROACH 7

 5.1 Rationale 7

 5.2 Temperature Rationale 9

 5.3 Temperature Fixturing 11

 5.4 Memory Exerciser 13

 5.5 Test Algorithms 13

 5.6 Sample Selection Criteria 14

6.0 PRESENTATION AND EXPLANATION OF THE DATA 15

APPENDIX I 16K DYNAMIC RAM, VENDOR A 18

t_{RAC} (Access time from \overline{RAS}) 19

t_{CAC} (Access time from \overline{CAS}) 20

t_{RP} (\overline{RAS} precharge time) 21

t_{RAS} (Minimum \overline{RAS} pulse width) 22

t_{RSH} (\overline{RAS} hold time) 23

t_{CAS} (Minimum \overline{CAS} pulse width) 24

t_{ASR} (Row address setup time) 25

t_{RAH} (Row address hold time) 26

t_{ASC} (Column address setup time) 27

t_{RCS} (Read command setup time) 28

t_{WCH} (Write command hold time to \overline{CAS}) 29

t_{WCR} (Write command hold time to \overline{RAS}) 30

t_{WP} (Write command pulse width) 31

t_{RWL} (Write command to \overline{RAS} lead time) 32

| | |
|------|----|
| DATE | BY |
| | |
| | |
| | |
| | |
| | |
| | |
| | |

TABLE OF CONTENTS (continued)

APPENDIX I (continued)

| | |
|--|----|
| t_{CWL} (Write command to \overline{CAS} lead time) | 33 |
| $t_{DS(C)}$ (Data-in setup time referenced to \overline{CAS}) | 34 |
| $t_{DS(W)}$ (Data-in setup time referenced to write) | 35 |
| $t_{DH(C)}$ (Data-in hold time referenced to \overline{CAS}) | 36 |
| $t_{DH(W)}$ (Data-in hold time referenced to write) | 37 |
| t_{DHR} (Data-in hold time referenced to \overline{RAS}) | 38 |
| t_{REF} (Cell retention time refresh period) | 39 |
| t_{WCS} (Write command setup time) | 40 |
| \overline{CAS} to write delay (t_{CWD}) versus temperature | 41 |
| Output turn-off delay, \overline{CAS} rise to output high-Z | 42 |
| Device capacitance | 49 |
| Dynamic test setup for output current, Source current (I_{OH}) and Sink current (I_{OL}) | 50 |
| Source current (I_{OH}) | 51 |
| Sink current (I_{OL}) | 52 |
| V_{IH} (Minimum input up level--any input) | 53 |
| V_{IHC} (Minimum clock input up level--any clock) | 54 |
| V_{IL} (Maximum input down level--any input) | 55 |
| Power calculation chart | 56 |
| I_{DD1} (Operating current) | 57 |
| I_{DD2} (Standby current \overline{RAS} & \overline{CAS} inactive--high) | 58 |
| I_{BB1} (Operating current) | 59 |
| I_{CC} (Output driver supply current) | 60 |
| Power supply transient current test setup | 61 |
| I_{DD} (Power supply transient currents) | 62 |
| I_{SS} (Power supply transient currents) | 68 |

TABLE OF CONTENTS (continued)

APPENDIX I (continued)

| | |
|---|-----|
| Schmoo V_{DD} versus V_{BB} | 71 |
| APPENDIX II 16K DYNAMIC RAM, VENDOR B | 82 |
| t_{CAC} (Access time from \overline{CAS}) | 83 |
| t_{RAC} (Access time from \overline{RAS}) | 84 |
| t_{RP} (\overline{RAS} precharge time) | 85 |
| t_{RAH} (Row address hold time) | 86 |
| t_{ASC} (Column address setup time) | 87 |
| $t_{DS(W)}$ (Data in setup time to \overline{WRITE}) | 88 |
| Cell retention time refresh period t_{REF} | 89 |
| I_{DD1} (Operating current) | 90 |
| V_{IHC} versus temperature (Input level sensitivity) | 91 |
| Sink current (I_{OL}) | 92 |
| Source current (I_{OH}) | 93 |
| Schmoo V_{DD} versus V_{BB} | 94 |
| Power supply transient currents | 98 |
| APPENDIX III 16K DYNAMIC RAM, VENDOR C | 99 |
| t_{CAC} (Access time from \overline{CAS}) | 100 |
| t_{RAC} (Access time from \overline{RAS}) | 101 |
| t_{RP} (\overline{RAS} precharge time) | 102 |
| t_{RAH} (Row address hold time) | 103 |
| t_{ASC} (Column address setup time) | 104 |
| $t_{DS(W)}$ (Data in setup time to \overline{WRITE}) | 105 |
| Cell retention time refresh period t_{REF} | 106 |
| I_{DD1} (Operating current) | 107 |
| V_{IHC} versus temperature (Input level sensitivity) | 108 |
| Sink current (I_{OL}) | 109 |

TABLE OF CONTENTS (continued)

APPENDIX III (continued)

Source current (I_{OH}) 110
 Schmoos V_{DD} versus V_{BB} 111
 Power supply transient currents 114

APPENDIX IV 16K DYNAMIC RAM, PARAMETER COMPARISON PLOTS 115

t_{RAC} versus temperature (Access time from the row address strobe). 116
 t_{RP} versus temperature (Row address strobe precharge time) 117
 t_{RAH} versus temperature (Row address hold time) 118
 Operating I_{DD} versus temperature 119
 Sink current (I_{OL}) versus temperature 120
 Device capacitance 121

APPENDIX V 16K DYNAMIC RAM, RECOMMENDED PARAMETER LIMITS 122

16K dynamic RAM rev. G date code 7751, AC characterization
 data overview 123
 16K dynamic RAM rev. G date code 7751, DC characterization
 data overview 124
 16K dynamic RAM - Timing (Read Cycle) 125
 16K dynamic RAM - Timing (Write Cycle) 126

APPENDIX VI 16K DYNAMIC RAM, TEST ALGORITHMS 127

16K Dynamic RAM 128
 Pattern 1 128
 Pattern 2 128
 Pattern 3 129
 Pattern 4 129
 Pattern 5 130
 Pattern 6 130
 Pattern 7 131

EVALUATION

The prime objective of this study was to electrically characterize and specify in MIL-M-38510 detail specification format 16K bit dynamic random access memories (RAMs). Several different vendors' devices were to be evaluated to assure second source advantages of cost and delivery.

The specific approach to accomplish the above objectives was to perform a complete electrical characterization of 16K RAMs from the industry leader, referred to as "Vendor A" in this report. At the completion of this task other vendors' devices were to be selected and the critical electrical parameters evaluated. From the resulting data, a detailed MIL-M-38510 specification was to be prepared.

The results of this effort, as verified in this report, were successful in achieving the desired results. The 16K dynamic RAM available from at least three large semiconductor vendors was completely characterized and specified in MIL-M-38510 format. In fact, the resulting specification, nomenclatured M38510/240, was issued, coordinated and dated during the course of this contract.

This specification contains a comprehensive list of a-c and d-c parameters along with algorithmic test patterns needed to assure the electrical integrity of 16K dynamic RAMs. Critical tests peculiar to 16K dynamic RAMs, such as the "bump test" to guarantee sense amplifier performance are contained in this specification. Alpha particle emission from the packaging materials that can cause soft memory errors is also treated in this specification as an initial attempt at quantifying the effects of the problem in system operation. Future studies of the effects in alpha particles on dynamic RAMs will be pursued at RADC.

RADC, as preparing activity of MIL-M-38510, is responsible for managing the development and preparation of detail slash sheets for this specification. This study and future studies of this type will be continued to assure that the MIL-M-38510 detail specifications are electrically accurate, cost effective, timely and capable of guaranteeing that microcircuits will perform as specified in design applications.

Regis C. Hilow

REGIS C. HILOW
Project Engineer

1.0 INTRODUCTION

The evolution of the 16K dynamic RAM is a result of one of the keenest concerted efforts by the semiconductor memory industry to date to provide the user base with a standard form, fit, and function memory device. The primary reason for its immediate acceptance by the user was its basic functional concept. With this functional concept well defined, the semiconductor industry was both ready and capable of producing such a high density device. Since its introduction in early 1976, capabilities such as a mature double polysilicon process and a complete menu of third-generation dynamic circuit techniques have come together throughout a broad segment of the industry to provide the user with the most attractive cost/performance memory technology to date.

The wide temperature range performance inherent in most designs has made it possible for the government to be offered these same cost/performance advantages in many main store applications. With this in mind, IBM Federal Systems Division (FSD) has performed electrical characterizations on 16K dynamic RAMs for this purpose. As a separate but related data item, a draft of the MIL-M-38510/240 military specification for the 16K dynamic RAM was prepared and submitted to RADC as part of this project.

This final report is comprised of a large quantity of reduced data which justifies the limits set forth in the proposed draft specification. It is hoped that it will serve as a comparison reference manual for future product designs and revisions.

The explanation of the operation of the 16K dynamic RAM is covered in numerous data books, articles, and application notes and will not be repeated in this report. Lengthy comments and wording are also minimized.

2.0 OBJECTIVES OF THE PROJECT

The objectives of the project were as follows:

1. Characterize a popular version of a 16K RAM for the purpose of establishing draft specification limits.
2. Demonstrate on a "best effort" basis that alternate devices made by more than one vendor are interchangeable on a pin and performance basis.
3. Generate a draft 38510 slash sheet specification for the 16K RAM using characterization data as a basis for establishing performance limits.

3.0 CONCLUSIONS

All objectives of the project were met or exceeded. With respect to "device interchangeability" aspects, reduced effort characterizations were performed during a two-month time window (April through May 1978). Therefore, for those vendors whose "production runner" was not available during that period, only a limited amount of data, consisting of highlight parameters (i.e., t_{RAC} , I_{DD1} , etc.), was collected on those particular devices.

It has been concluded that companies in the merchant semiconductor industry can supply a 16K dynamic RAM that will operate over the temperature range of -55°C case (instant on) to $+110^{\circ}\text{C}$ case (operating) with an access/cycle time of 200 NS MAX/375 NS MIN, a power supply tolerance of ± 10 percent, and a retention time of 1.0 MS minimum.

The data presented in Appendices I (Vendor A), II (Vendor B), III (Vendor C), and IV (Parameter Comparison Plots) are the basis for the conclusion. The recommended limits for all parameters are given in Appendix V (Recommended Parameter Limits).

Examination of the input high level data shows that the 2.7 V MIN generally specified by data sheets can safely be lowered to 2.4 V MIN which permits the device to be truly TTL compatible on all inputs. All three vendors, whose data is shown in the appendices, have subsequently agreed to the 2.4 V MIN up level for all inputs.

Cell retention time, one of the main concerns, is not a significant yield detractor at 110°C case temperature. The data shows that only a few of the samples did not meet the 1.0 MS MIN limit. With further process improvements and circuit adjustments, particularly those intended to reduce the device's vulnerability to alpha particle induced soft errors, should minimize the data retention time issue. The reasons for this improvement is discussed in section 5.0 in greater detail.

It is genuinely felt that the parameter limits set forth in Appendix V, with minor exceptions, will satisfy the majority of users and suppliers. Device interchangeability by several different sources is clearly demonstrated in Appendix IV.

4.0 PROFILE OF A 16K DYNAMIC RAM

In advance of describing the approach for achieving the objectives, it is perhaps best to give some perspective to the device being addressed by this project. The following table illustrates some aspects of the process, design, performance, and packaging. The entries, which consist of data accumulated over one year, are still changing, particularly in light of the recent alpha particle soft error discovery.

16K DYNAMIC RAM PROFILE

| | <u>Range</u> | <u>Most Common</u> |
|----------------------------------|---|----------------------|
| Number of U. S. Vendors | 9 | N/A |
| Ground Rules | 4-6 μ | 5 μ |
| Oxide Thickness | 800-1000 Å | 850 Å |
| Diffusion Depth | 0.7-1.2 μ | 1.2 μ |
| Die Size | 22-34K mil ² | 23K mil ² |
| Array/Chip Area Ratio | ~42-50% | ~50% |
| Cell/Bit Line Ratio | 1/9-1/20 | 1/18 |
| Cell Capacitance | 0.032-0.080 PF | 0.05 PF |
| Data Matrices | 2-4 | 2 |
| Number of Sense Amps | 128-256 | 128 |
| Sense Amps | Static-Dynamic | Dynamic |
| Access (t _{RAC})/Cycle | 150-300/320-410 NS | 200/375 NS |
| Operate/Standby Power (typ) | 260-385/6-20 MW | 300/12 MW |
| Supply Voltages | +12V,+5V,-5V \pm 10% | Same |
| Packages | 16 PIN DIP/FP or 18 PIN carrier modules consisting of stacked DIPS or multiple carriers on a pinned substrate are also available. | |

Common to all these designs is the use of metal word lines and diffused bit lines, unlike at least one Japanese version where the opposite is true. Buried contacts are used extensively, and in some cases, second level poly has been used in the peripheral support circuits.

There is little variation in the one-device double polysilicon cell structure. Most are fabricated with six or seven mask NMOS processes.

From a circuit standpoint, at least one manufacturer uses static sense amplifiers and 4-storage matrices. This arrangement uses 256 sense amplifiers with 32 cells on each of the balanced bit lines. A large sensing margin is achieved partially due to the low bit line to cell capacitance ratio allowing more freedom in setting the value of the sense amp trip point. Much more common is the 128-dynamic sense amp scheme which incorporates 64 cells on each bit line half. Although the high bit line to cell capacitance ratio reduces the signal swing, present day designs have, in the process of reducing susceptibility to alpha particle induced soft errors, made process changes that tend to increase the cell capacitance as well as store a much higher signal on it. The resulting high signal swing also gives some added freedom for choosing the trip point of the sense amplifier. For both the static and dynamic versions, the large signal swings have allowed for trip point settings which result in an "apparent" data retention time improvement.

The input circuits (except clocks), shown in Figure 1, are comprised of latches having a signal input and a reference input and an associated holding capacitor for each. The holding capacitors are gated off immediately after $\overline{\text{RAS}}$ or $\overline{\text{CAS}}$ becomes active so that the latch may progress in a changing state while the input signals are changing

to a new value. In some cases, a common mode boost signal is applied to the gates of both sides of the input latch to ensure that the correct side turns on.

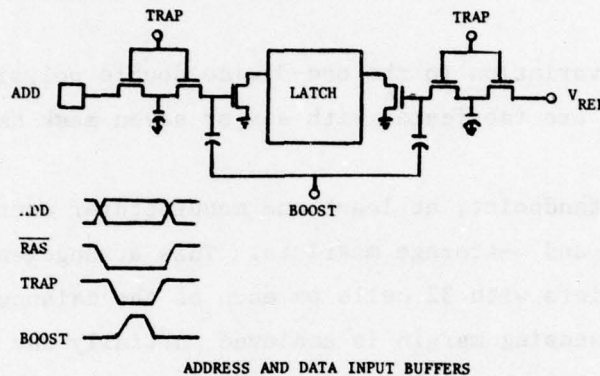

Figure 1

Input level compatibility with TTL circuits for all inputs including clocks is now guaranteed and advertised by many suppliers.

The clock inputs are slight modifications of a standard boot strapped inverter which does account for nearly all the standby power consumption of the device except in those cases where static sense amplifiers are employed. Since the bulk of the operating power is dynamic, it is a direct function of frequency and the duration of the active $\overline{\text{RAS}}$ time. As a result, some devices having a high component of static power may meet a specification for a given cycle time and $\overline{\text{RAS}}$ active time, but when used in an application where the $\overline{\text{RAS}}$ active time to cycle time ratio approaches one, the power dissipation could become many times that of a fully dynamic part and for that particular application could not be considered interchangeable with it.

Data retention time is 10 to 20 times better than that exhibited by early versions of the 16K RAM. This is due, in part, to higher signal swings and lower sense amp trip point values. Other improvements such as diffused guard rings around the periphery of the storage matrix and improved gettering have reduced cell leakage currents.

From the author's viewpoint, the most impressive section of the RAM design is the control timing generator. Over 20 precisely timed control signals, some that operate twice each cycle, are developed to synchronize the orderly sequence of events. It is the generator that provides the dynamics for the dynamic RAM.

Finally, since the operating basis for the dynamic RAM amounts essentially to the charging and discharging of capacitors, which accounts for very low power per bit, the profile of the power supply current waveforms demand that good high frequency decoupling in moderate to large amounts be placed strategically throughout the second level assembly for the VDD (+12V) and VBB (-5V) supplies.

5.0 CHARACTERIZATION APPROACH

5.1 RATIONALE

The philosophy established at the outset of the projects was to arrive at a set of specification limits that were both attractive to a user and deliverable by the industry with very little added in the way of special electrical tests. Rather than testing a large number of samples from one vendor, the assets were used to collect data from fewer samples representing several suppliers instead.

This philosophy had proven to be the correct one considering the frequent number of design tweaks and die shrinks that have occurred during the span of the project.

For a reasonable given set of constraints, it is not possible or even desirable to characterize indefinitely the large number of design variations from every supplier. During the last quarter of 1977, a quick snapshot view of devices from the industry (nine United States manufacturers) showed that although all had a good set of goals and plans, the individual designs showed varying degrees of maturity. The strengths and weaknesses of many of the designs could definitely be seen at that time. The original plan of choosing one of the most stable and popular designs for a full characterization was implemented with the intent of looking at designs from other manufacturers at a later date when prospects would be better for getting production versions.

Following the above course led to the full characterization of devices from Vendor A (see Appendix I). Subsequent characterizations of Vendors B and C were also performed (see Appendices II and III). The highlight parameters are plotted and shown in Appendix IV.

In order to give some perspective to the project in relation to the production ramp-up of the 16K RAM, the following is offered. Approximately nine months after the outset of the project, the list of nine United States manufacturers has grown to eleven. According to Dataquest estimates (July 14, 1978, Dataquest newsletter), only three of these United States companies are shipping at a rate of 500K or more units per quarter, five are shipping 50K units per quarter, and the remaining are still in the sampling stage.

The foregoing illustrates that although the 16K RAM is a viable product, many changes and much "learning" is still taking place within the industry. New processes or designs aimed at reducing alpha particle vulnerability is also proliferating the number of devices that are available to consider. The overall point, re-emphasized, is that the characterizations performed were done with the intent of determining mutually reasonable specification limits for the purpose of providing the government with a draft document for procuring devices on a timely basis from more than one source at a reasonable cost and minimum procurement risk. No attempt was made to establish binning criteria or parameter distribution for any vendor's product.

5.2 TEMPERATURE RATIONALE

Because the most important parameter of a dynamic RAM, data retention time, is a strong function of temperature (halving every 5-20°C), the previously accepted but vague concept of ambient temperature is not acceptable for characterization purposes. There is a wide variation of conditions for specifying as well as for interpreting the meaning of this term. In system thermal definition and analysis, it is not a usable parameter. In some military high-altitude applications, for example, there is no "air," still or moving, demonstrating the inadequacy of the standard "ambient" temperature specification. Even in commercial applications, the temperature environment is usually modified by fans or heat sinks or other conduction methods all of which require a more accurate method for specifying device temperature.

As a better choice, junction temperature seems at first to be more useful since junction-to-case thermal resistance has been measured and calculated and is related only to the properties and dimensions of the chip and package. However, one is sometimes faced with the problem of defining just where and at what temperature the precise junction is. To date, direct measurement of temperature at the precise junction locations has not been practical, although temperatures in the "junction vicinity" have. Models have been developed to calculate precise junction temperatures but cannot be experimentally verified. Therefore, to circumvent this age old problem, of which the author is well aware, a more practical concept has been set forth, one that is suitable for engineering or production environments.

For the purpose of this project, junction temperature is defined as the average bulk temperature of the silicon chip. This is an easily acceptable definition if it is remembered that in memory devices the power is dissipated quite evenly across the chip. In this particular case, the 16K RAM device chip temperature was measured with an infrared radiometric microscope while the chip was being sequentially addressed at a 375 NS cycle rate. The resultant "junction" to case thermal resistance was three to five degrees C per watt referenced to the bottom side center of the 16 pin DIP. This number was verified on two radiometer setups and was subsequently verified by one device vendor.

Further, it is realized that this method as well as others could be considered controversial or not acceptable by some; however, it was used to estimate junction temperatures in this characterization and has proven to be usable. To further remove any ambiguity, it was

decided to specify the device temperature range in terms of case temperature measured at the bottom center of the DIP. In addition, the junction-to-case thermal resistance is specified at $15^{\circ}\text{C}/\text{watt}$ maximum (three times the measured value) to account for measurement variations. Within this framework, the junction temperature for electrical or reliability concerns is considered to be less than 7°C above the case temperature at cycle times of 375 NS.

5.3 TEMPERATURE FIXTURING

The temperature forcing system used for the entire range of -55°C to $+110^{\circ}\text{C}$ case was a Temptronic hot probe (Model TP 26/27H) and cold probe (Model TP 27C). Temperature measurements were made with a Digitec Thermocouple Thermometer (Model 590 TC Type T). A 20-mil diameter copper constantan thermocouple was attached to the device socket with a small piece of low emissivity tape.

The thermocouple is an averaging device and therefore measures the average of everything that contacts the junction bead and therefore must be calibrated to case temperature. When a thermospot forcing system is used, a hot or cold probe is brought in contact with the lid of the test package. When the hot probe is used, the heat flow is downward toward the device, socket, and card. Conversely, when the cold probe is used, the heat flow is in the opposite direction and toward the probe. Therefore, when measuring case temperature, the thermometer reading will contain a negative error when the hot probe is used and a positive error when the cold probe is used. Put another way, the actual case temperature will be higher than indicated at high temperatures and lower than indicated at low temperatures.

To quantify this error, the entire card, thermocouple, and device are put in an oven having fan-forced violent air movement. The device is unpowered, and under these conditions the case, socket, card, and entire thermocouple bead are assumed to be at the same temperature. A low current (100 UA) is passed through an input protection diode while no other power is applied to the chip. At several temperatures over the -55°C to $+110^{\circ}\text{C}$ range, both the value to the thermometer indicator and the diode voltage is plotted.

Next, with the device, socket, and thermocouple still intact, the card is transferred to the thermal probe fixture where all future characterizations will be done. Here, the calibration curve is completed by adjusting the temperature for diode voltage readings previously obtained and recording the indicated temperature. This curve is illustrated in Figure 2 below.

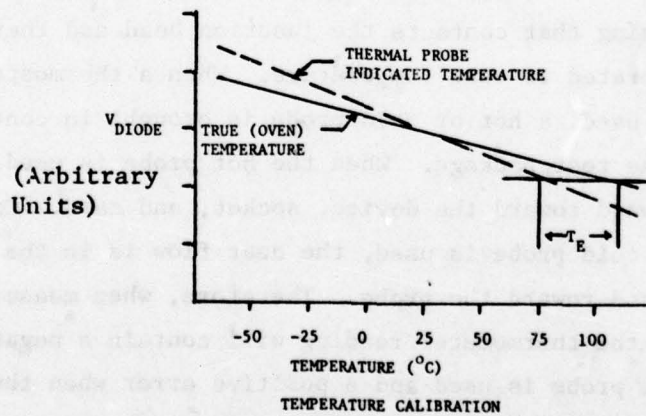

Figure 2

Referring to the illustration, the true case temperature is taken to be that measured in the oven environment. The fixturing error is the difference between the oven fixture indications and the thermal probe fixture indications. For this particular project, the error was found to be:

$$T_E = 0.04 (T-25)^{\circ}\text{C}$$

where T = the indicated thermometer reading

where T_E = the error in the indicated thermometer reading

$$T_{\text{case}} = T + T_E = T + 0.04 (T-25)$$

$$T_{\text{case}} = 1.04T - 1^{\circ}\text{C}$$

The repeatability of the setup was determined to be within 0.5°C at an indicated reading of 100°C .

5.4 MEMORY EXERCISER

The memory exerciser used for all testing was a Siemens Venture V200 geared primarily for engineering characterizations. The exerciser is equipped with a topological memory for both the X and Y address fields. All devices were tested in a topologically pure fashion using topo maps readily available from each vendor.

5.5 TEST ALGORITHMS

The test algorithms are given in Appendix VI. Functional algorithms are test patterns which define the exact sequence of events used to verify proper operation of a random access memory. Each algorithm serves a specific purpose. Appendix VI gives detailed

descriptions of the patterns used for device characterization. All are commonly known patterns and should be quite simple for most test systems to implement. The subject of identifying the ideal efficient pattern (i.e., minimum test time/maximum effectiveness) is not within the scope of this project. Separate studies have been performed on this subject, but it is too early to draw a conclusion based on these algorithms being used in actual production or failure analysis testing. Nonetheless, the economic importance of this subject is recognized and will be addressed in future activities.

5.6 SAMPLE SELECTION CRITERIA

One of the primary objectives of the project was to provide a set of specifications for the 16K dynamic RAM that would afford the government the same cost/performance advantages available to private industry. To assist in achieving this goal, the samples were chosen to implement the following plan:

- a. Procure and test 25 commercial grade (0° to 70°C) RAMs from several vendors and determine the performance and extended temperature range capabilities inherent in each of the designs.
- b. Fully characterize 25 samples of a popular version and follow with at least two additional versions.
- c. Write a draft specification, using the characterization data base, the industry can meet with as little additional special testing as possible.

The selection of samples prescreened to any criteria other than that outlined on the previous page would have biased the outcome and made it impossible to achieve the original goal.

6.0 PRESENTATION AND EXPLANATION OF THE DATA

All electrical measurements were taken at -55°C , $+25^{\circ}\text{C}$, and $+110^{\circ}\text{C}$ case temperature. After reduction, it was plotted to a smooth curve format so that parameter values could be lifted for other intermediate temperatures.

The AC data was plotted to a particular and useful format. All data concerning a single parameter is presented on a single page. The first plot at the top of the page shows the cumulative distribution of the sample group for that parameter. A glance at this plot shows if maverick parts exist in the sample. The second plot shows how the parameter varies with power supply voltage (V_{DD}), while the third plot illustrates how the parameter performs over the full temperature range.

Cell retention was measured at three elevated temperature points (90°C , 100°C , and 110°C case) using pattern five in Appendix VI. These plots show retention time halving every 5° to 20°C with 12°C being typical. Slopes of retention time versus temperature do not seem to be related to the absolute value at any temperature. Thus, a device having a low retention time and shallow slope initially at a given temperature might have a longer retention time than one starting with a higher initial value having a steeper slope when both are measured at a higher temperature. In any case, a 1.0 MS MIN limit at 110°C case can be met with little fallout.

Plots of output source and sink capability were made on a pulsed basis since the output is at a valid level for only a short 10 USEC interval.

TYPICAL OUTPUT RESISTANCE (OHMS)

| | | <u>Vendor A</u> | <u>Vendor B</u> | <u>Vendor C</u> |
|-----------------|--------|-----------------|-----------------|-----------------|
| <u>Sourcing</u> | -55°C | 98 | 42 | 46 |
| | +25°C | 126 | 58 | 66 |
| | +110°C | 159 | 82 | 93 |
| <u>Sinking</u> | -55°C | 21 | 13 | 16 |
| | +25°C | 31 | 20 | 26 |
| | +110°C | 44 | 29 | 38 |

An empirically derived equation for calculating standby and operating current is shown in Appendix I for Vendor A. Some published equations are derived from a slope of I_{DD1} vs frequency where the intercept of the current axis for \overline{RAS} and \overline{CAS} is active when the frequency is zero. In a system design, this would not usually be the case, as one would normally make \overline{CAS} and \overline{RAS} inactive for this condition. In very large systems, this seemingly minor error could have a heavy impact on the choice of the power regulators. The equation shown is included to serve only as an example.

The last set of plots for each vendor show the V_{DD} vs V_{BB} schmoos. These schmoos indicate a large margin of operation for supply voltages. Both a 5% and a 10% "box" are shown. For the characterization, the V_{BB} power supply was limited to -7.0 V maximum and the V_{DD} supply was limited to 15.0 V maximum to remove the possibility

of accidentally exceeding the maximum 22.0 V breakdown limit since the sample size was small. The only notable point is that the left edge of the schmoos are different--Vendor A is rather abrupt while Vendor B is more rounded. Vendor B plots also show wide variation in V_{BB} dependency from device to device, but since schmoo boundaries are generally determined by a relatively few number of cells on the chip, no great significance can be attached to that behavior, particularly if the tight schmoo (Unit #8) is not a trend.

Appendix IV, Parameter Comparison Plots, is included as a convenient comparison of the highlight parameters (t_{RAC} , t_{CAC} , I_{DD1} , etc.). The dotted lines on the plot indicate the proposed spec limit for that parameter. The intent here is to demonstrate to a high degree that the devices are interchangeable for all the proposed limits. To this end also, a memory system was populated with a mixture of devices from the three vendors and has operated over the full -55° to $+110^{\circ}$ C environment.

Appendix V is a list of the 39 AC and 19 DC proposed parameter limits that reflect the results of the data obtained from all of the characterizations.

APPENDIX I

16K DYNAMIC RAM

VENDOR A

Vendor: A
 P/N: _____
 REV: G
 Date Code: 7751
 # Devices: 25

16K DYNAMIC RAM
 ACCESS TIME FROM RAS
 t_{RAC}
 CUMULATIVE DISTRIBUTION

By F.A.N. Date 12/28/77
 V_{BB} -5.0V V_{CC} 5.0V
 LOAD 1 SCHOTTKY TTL + 50pF
 ADDR PAT. MULTIPLE
 DATA PAT. MULTIPLE

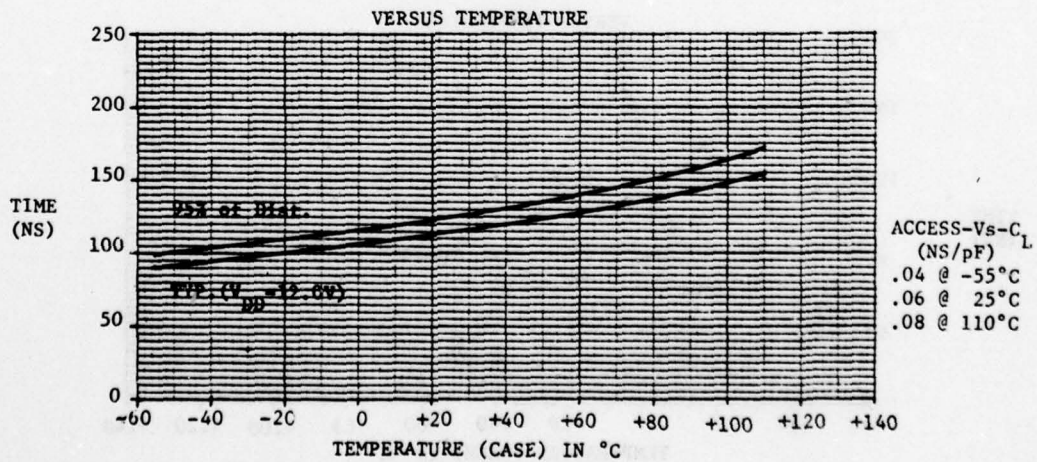
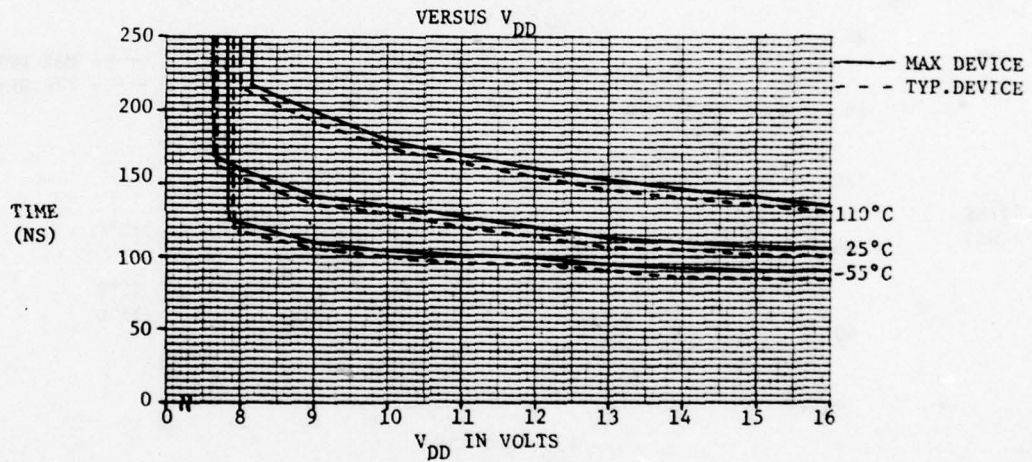
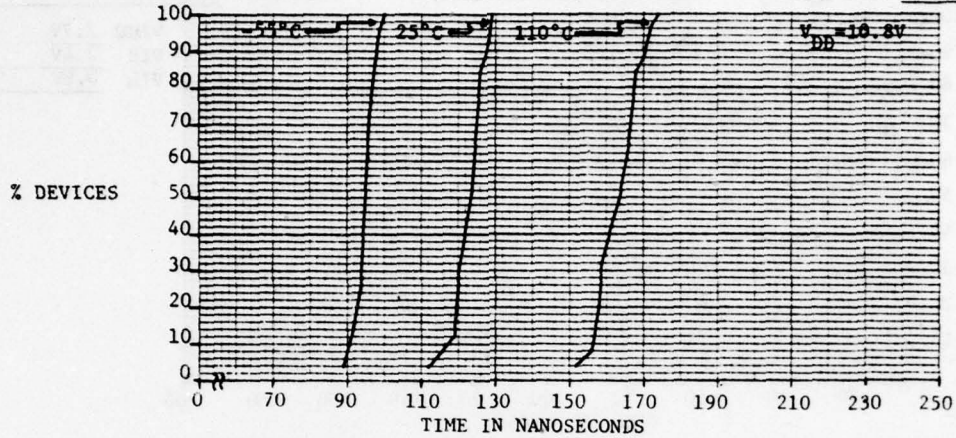

Vendor: A
 P/N: _____
 REV: G
 Date Code: 7751
 # Device: 25

16K DYNAMIC RAM
 ACCESS TIME FROM CAS
 t_{CAC}

By F.A.N. Date 12/29/77
 V_{BB} -5.0V V_{CC} 5.0V
 LOAD 1 SCHOTTKY TTL +50pF
 ADDR PAT. MULTIPLE
 DATA PAT. MULTIPLE

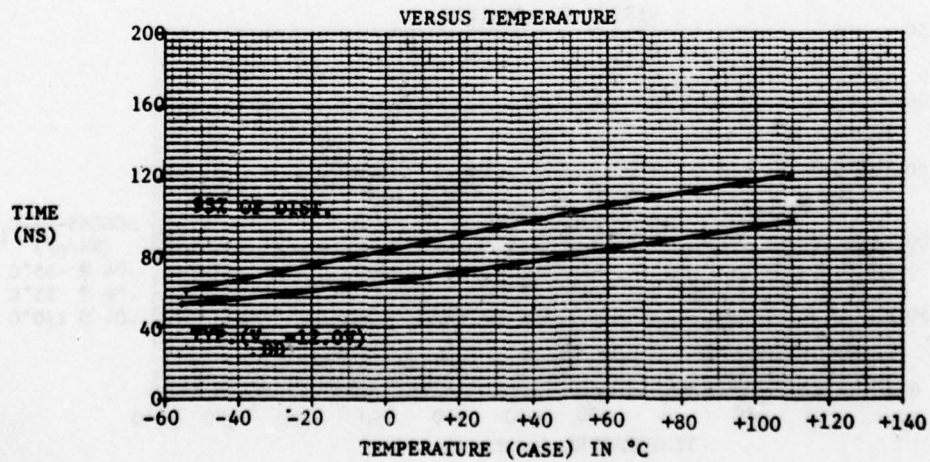
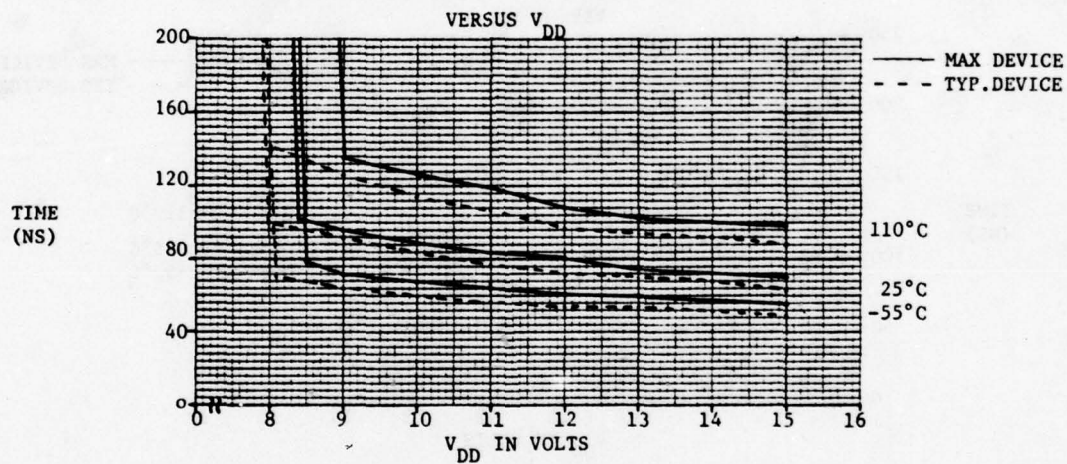
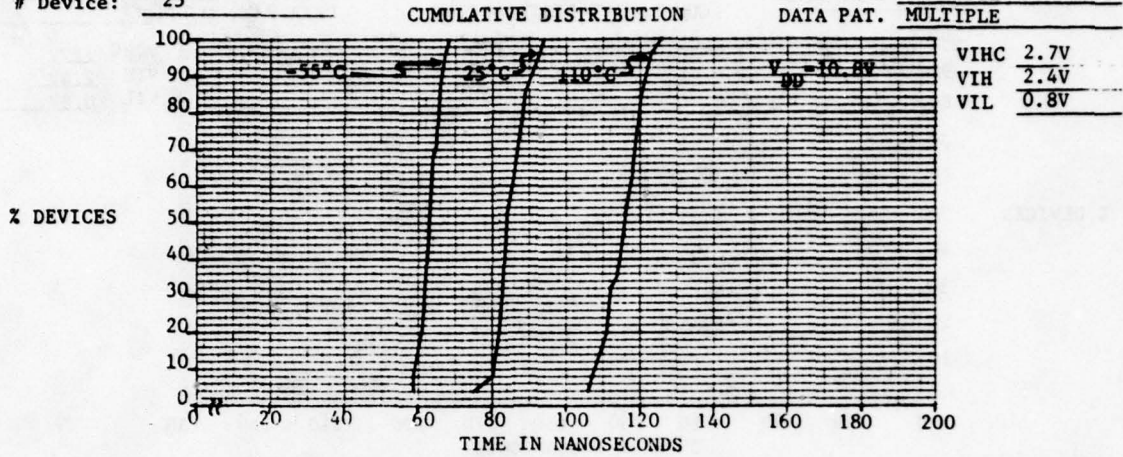

Vendor: A
 P/N: _____
 REV: G
 Date Code: 7751
 # Device: 25

16K DYNAMIC RAM
RAS PRECHARGE TIME
 t_{RP}

By J.R.F. Date 1/19/78
 V_{BB} -4.5V V_{CC} 5.0V
 LOAD N.A.
 ADDR PAT. MULTIPLE
 DATA PAT. MULTIPLE

% DEVICES

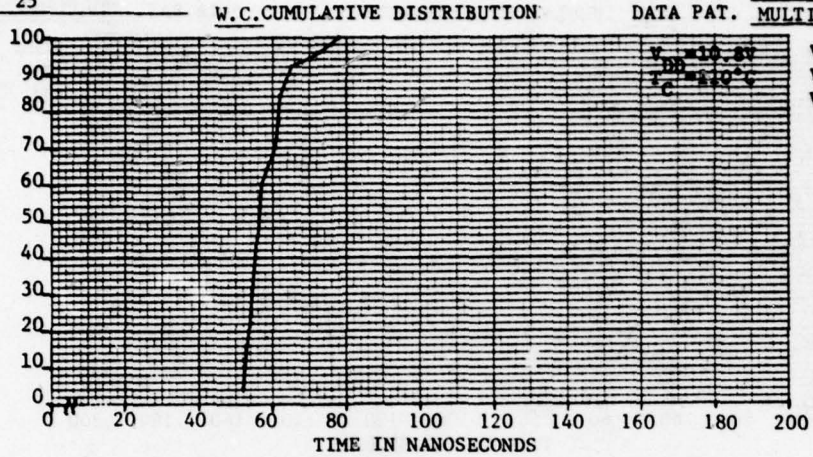

TIME (NS)

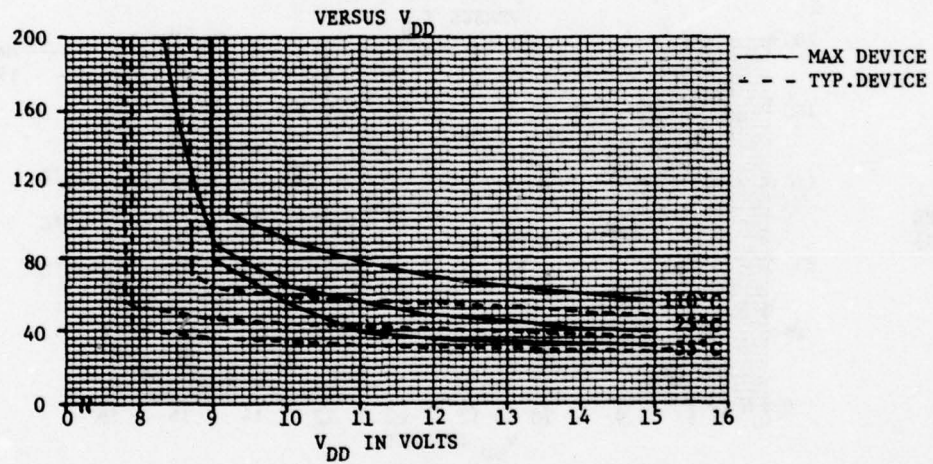

TIME (NS)

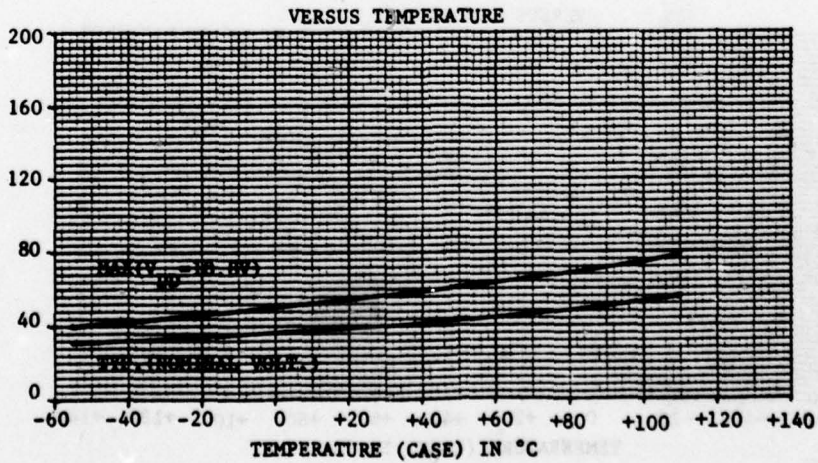

Vendor: A
 P/N: _____
 REV: C
 Date Code: 7751
 # Device: 25

16K DYNAMIC RAM
 MINIMUM RAS PULSE WIDTH
 t_{RAS}

By J.R.F. Date 1/19/78
 V_{BB} -4.5V V_{CC} 5.0V
 LOAD N.A.
 ADDR PAT. MULTIPLE
 DATA PAT. MULTIPLE

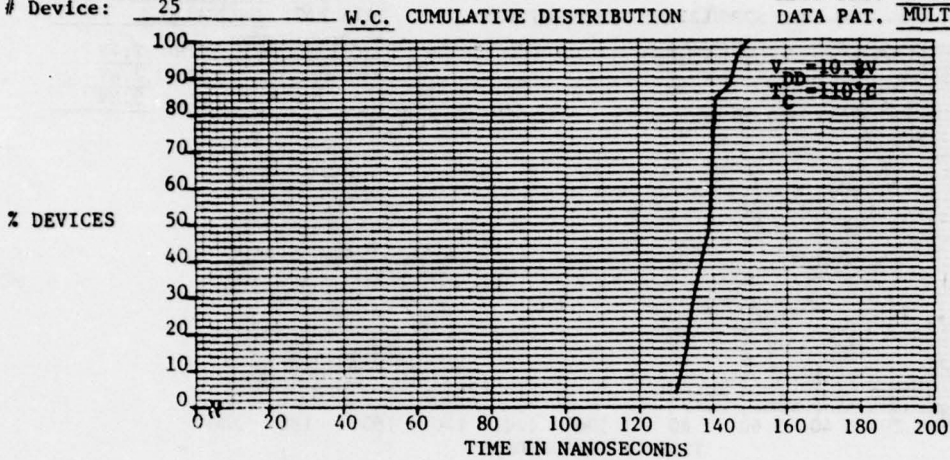

V_{IH} 2.7V
 V_{IH} 2.4V
 V_{IL} 0.8V

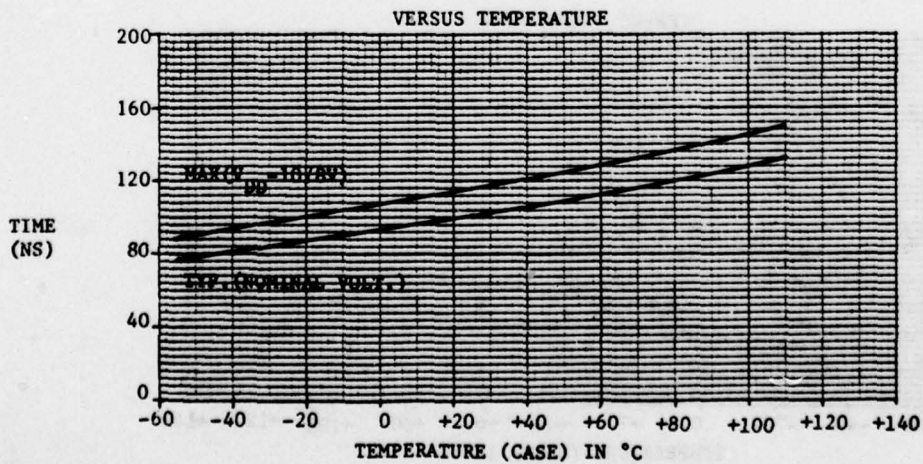
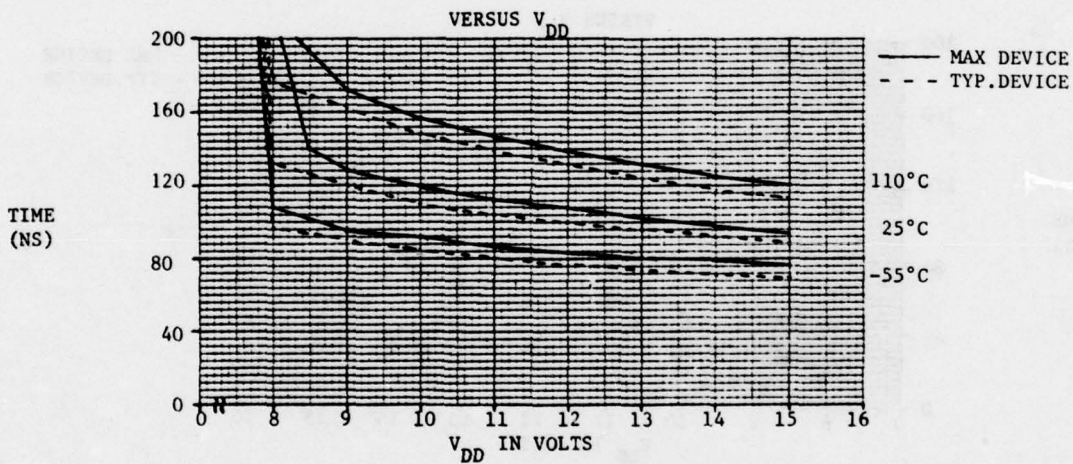

Vendor: A
 P/N: _____
 REV: G
 Date Code: 7751
 # Devices: 25

16K DYNAMIC RAM
 RAS HOLD TIME

By J.R.F. Date 1/20/78
 V_{BB} -4.5V V_{CC} 5.0V
 LOAD N.A.
 ADDR PAT. MULTIPLE
 DATA PAT. MULTIPLE

t_{RSH}
 W.C. CUMULATIVE DISTRIBUTION

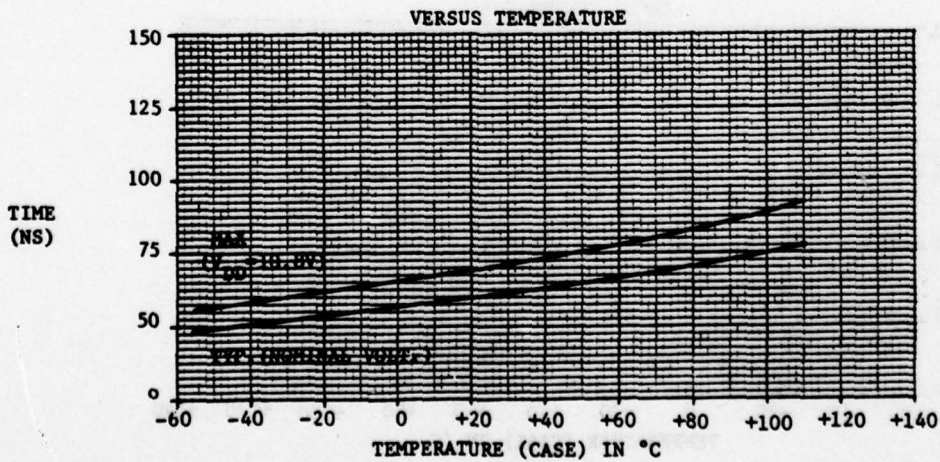
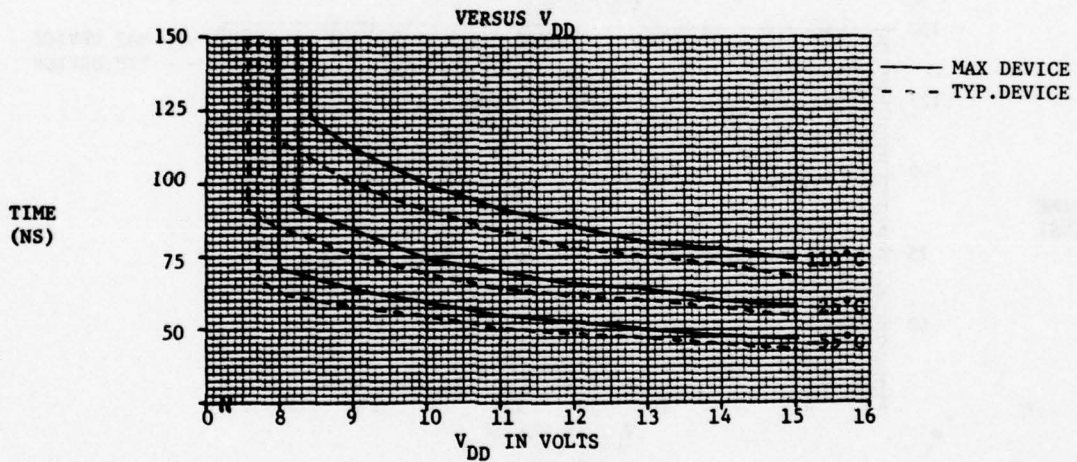
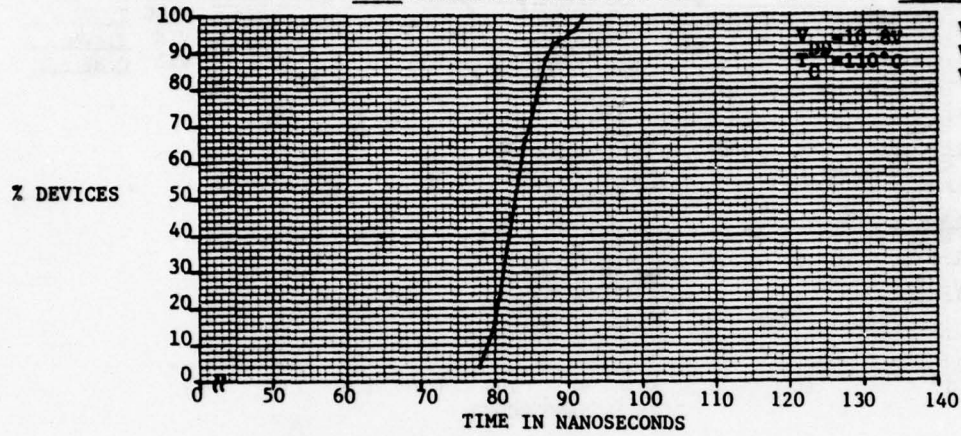

Vendor: A
P/N: _____
REV: G
Date Code: 7751
Devices: 25

16K DYNAMIC RAM
MINIMUM CAS PULSE WIDTH
 t_{CAS}
CUMULATIVE DISTRIBUTION

By J.R.F. Date 1/23/78
 V_{BB} -4.5V V_{CC} 5.0V
LOAD N.A.
ADDR PAT. MULTIPLE
DATA PAT. MULTIPLE

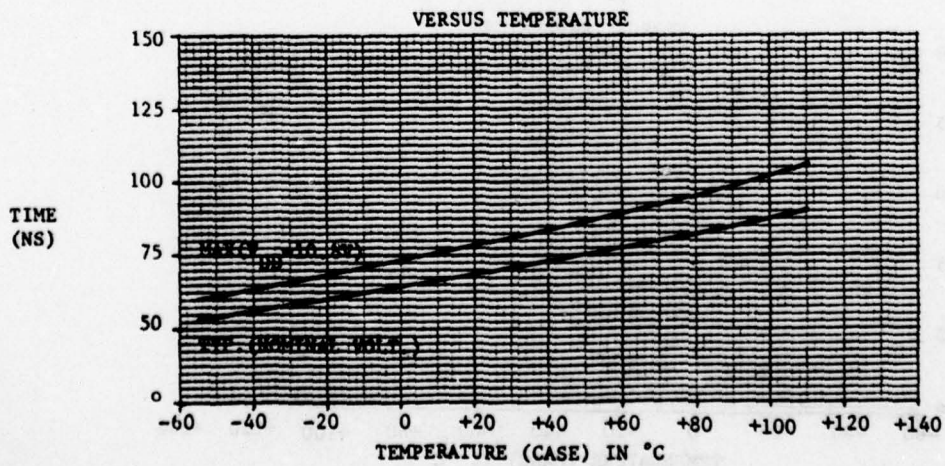
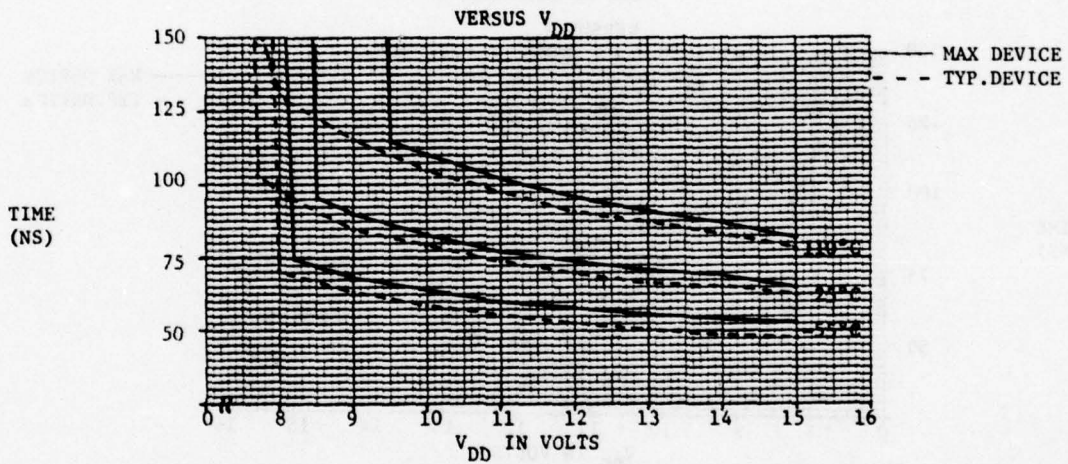
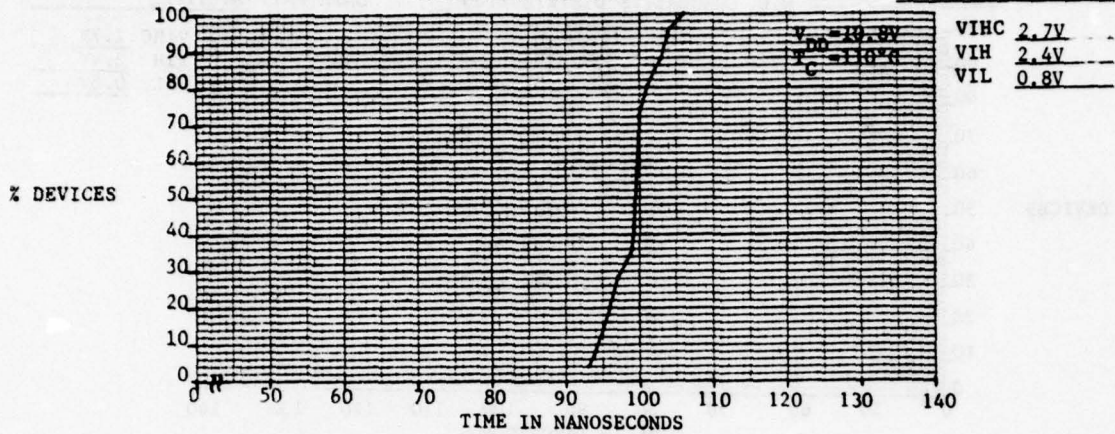

Vendor: A
 P/N: _____
 REV: G
 Date Code: 7751
 # Devices 25

16K DYNAMIC RAM
 ROW ADDRESS SETUP TIME
 t_{ASR}

By J.F.&F.N. Date 1/24/78
 V_{BB} -5.5V V_{CC} 5.0V
 LOAD N.A.
 ADDR PAT. MULTIPLE
 DATA PAT. MULTIPLE

W.C. CUMULATIVE DISTRIBUTION

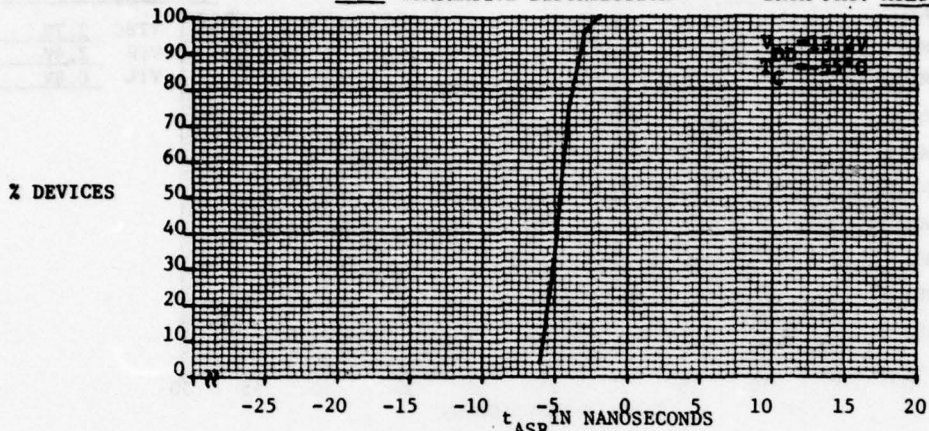

V_{IH} 2.7V
 V_{IH} 2.4V
 V_{IL} 0.8V

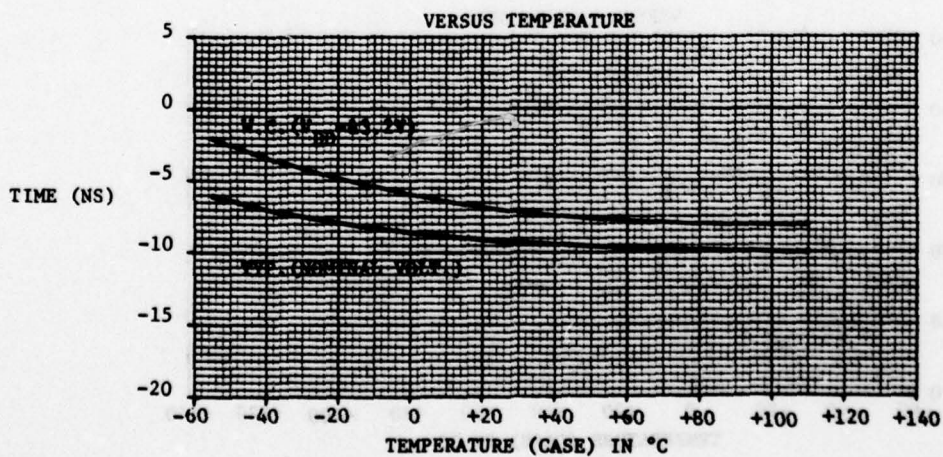
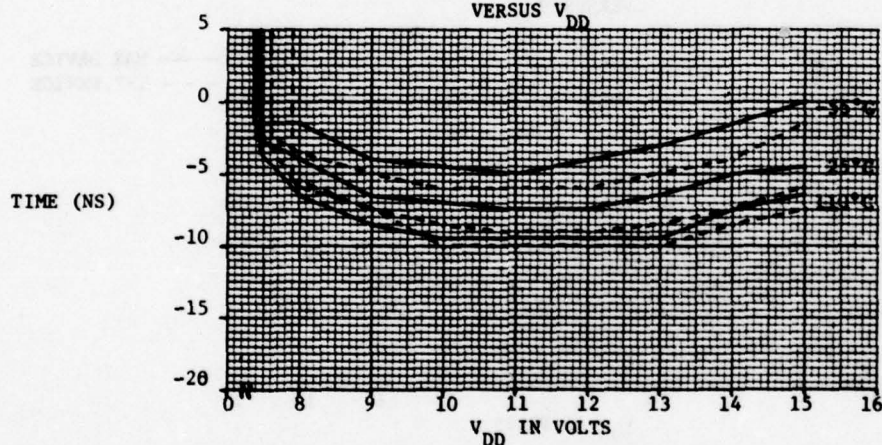

Vendor: A
 P/N: _____
 REV: G
 Date Code: 7751
 # DEVICES 25

16K DYNAMIC RAM
 ROW ADDRESS HOLD TIME

By J.F. & F.N. Date 1/24/78
 V_{BB} -4.5V V_{CC} 5.0V
 LOAD N.A.
 ADDR PAT. MULTIPLE
 DATA PAT. MULTIPLE

t_{RAH}

W.C. CUMULATIVE DISTRIBUTION

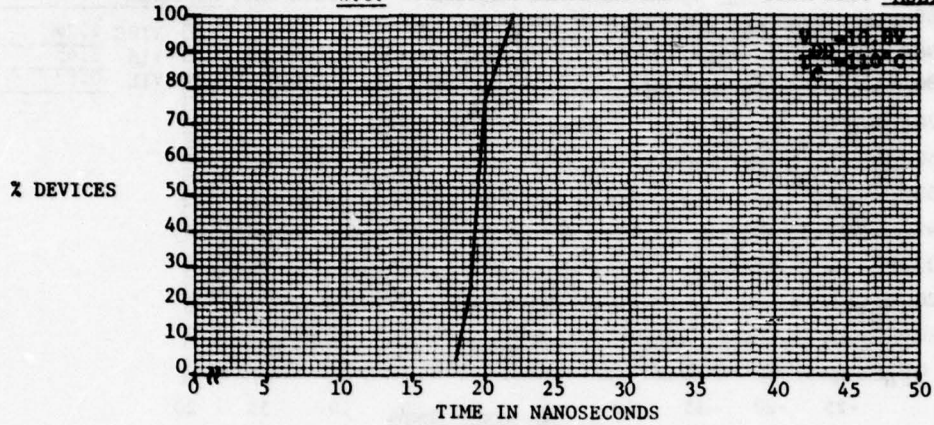

V_{IH} 2.7V
 V_{IH} 2.4V
 V_{IL} 0.8V

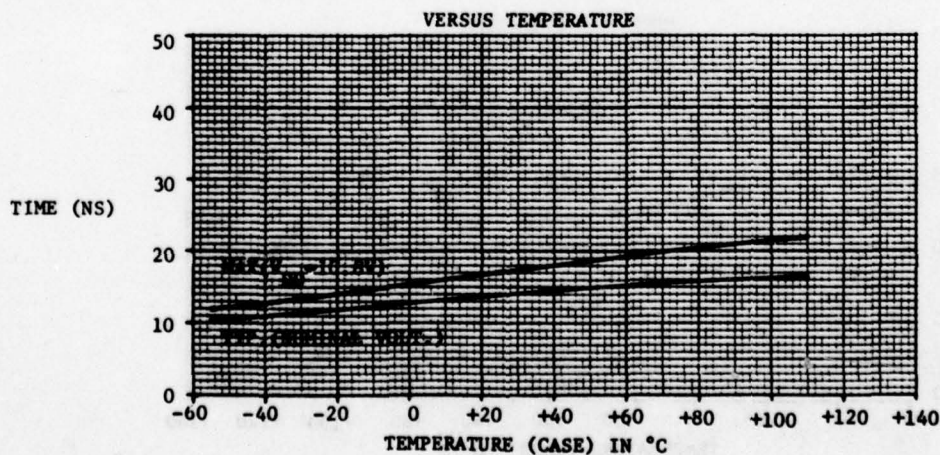
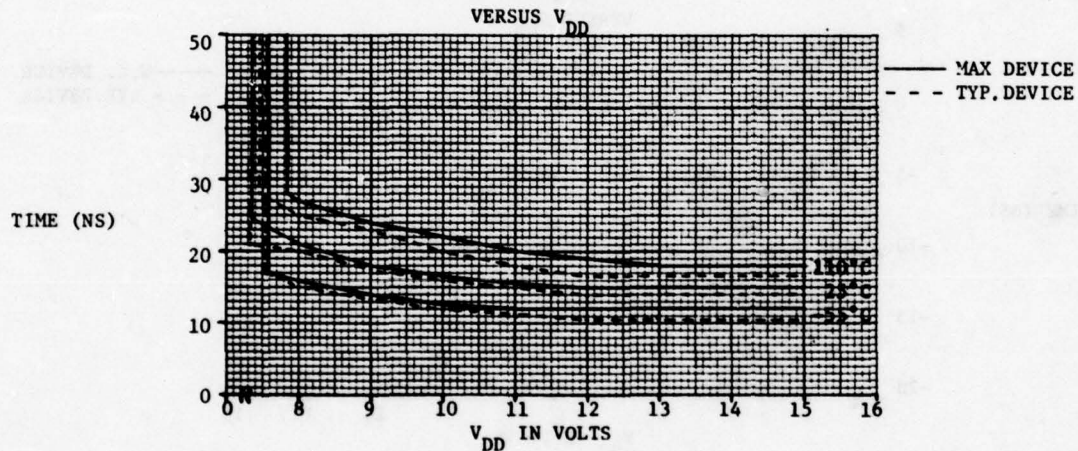

Vendor: A
 P/N: _____
 REV: G
 Date Code: 7751
 # DEVICES 25

16K DYNAMIC RAM
 COLUMN ADDRESS SETUP TIME
 t_{ASC}

By J.F. & F.N. Date 1/25/78
 V_{BB} -5.5V V_{CC} 5.0V
 LOAD N.A.
 ADDR PAT. MULTIPLE
 DATA PAT. MULTIPLE

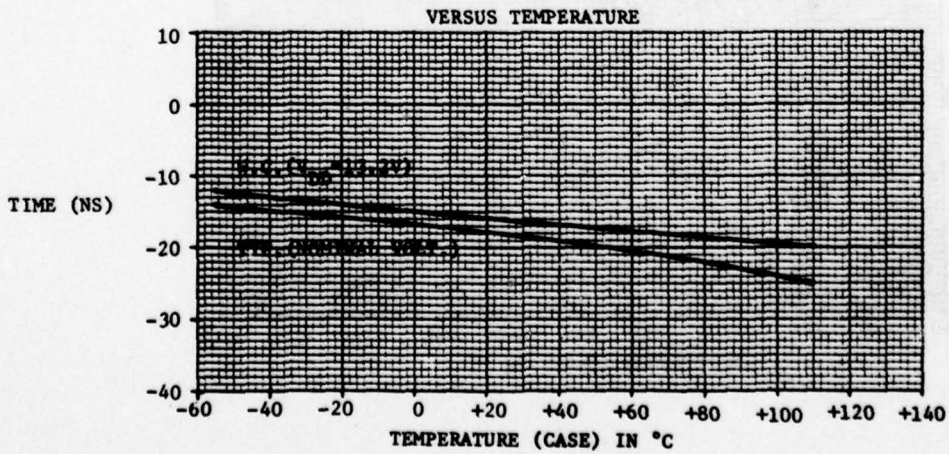
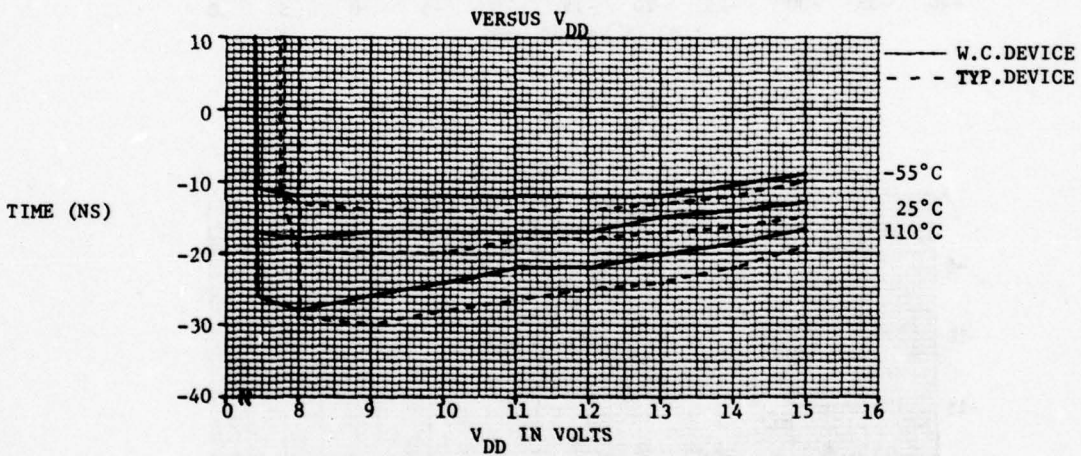
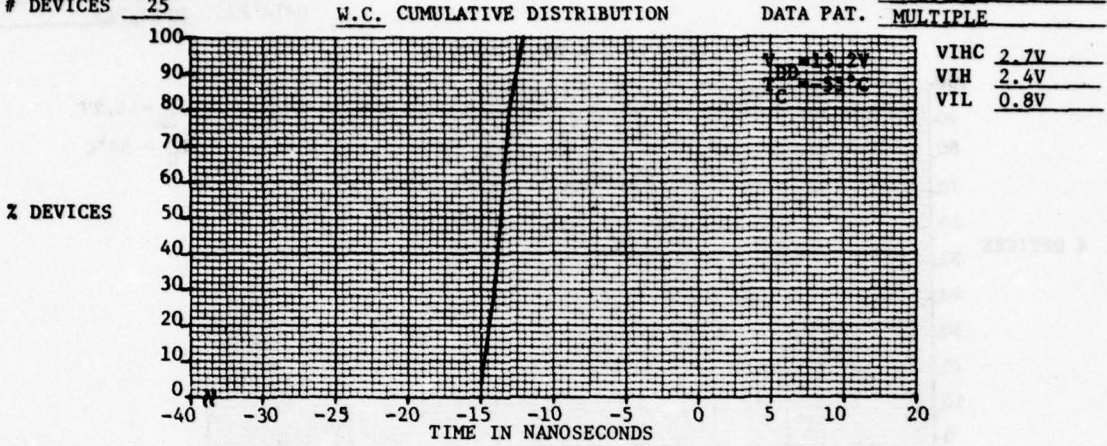

Vendor: A
 P/N: _____
 REV: G
 Date Code: 7751
 # DEVICES 25

16K DYNAMIC RAM
 READ COMMAND SET-UP TIME

t_{RCS}

By J.F. & F.N. Date 2/10/78
 V_{BB} -5.5V V_{CC} 5.0V
 LOAD N.A.
 ADDR PAT. MULTIPLE
 DATA PAT. MULTIPLE

W.C. CUMULATIVE DISTRIBUTION

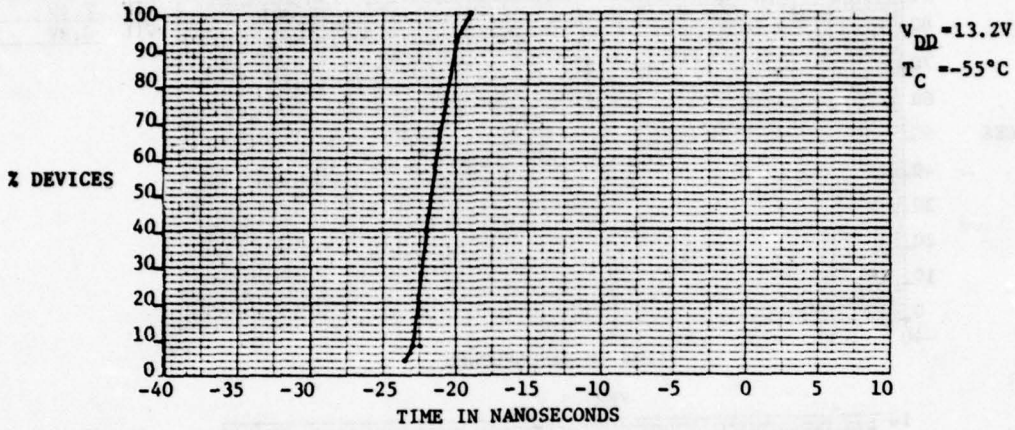

VERSUS TEMPERATURE

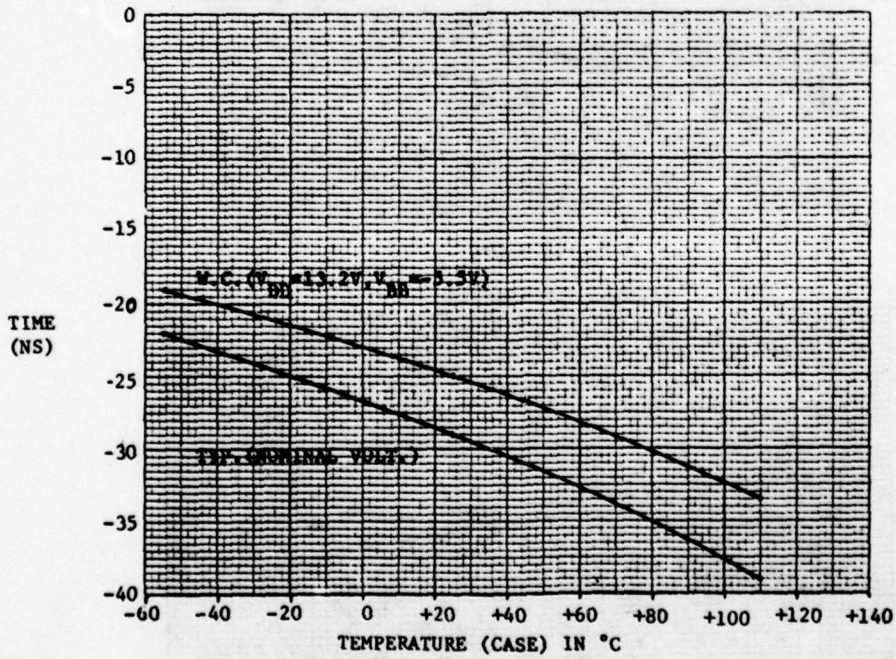

Vendor: A
 P/N: _____
 REV: G
 Date Code: 7751
 #DEVICES 25

16K DYNAMIC RAM
 WRITE COMMAND HOLD TIME TO $\overline{\text{CAS}}$
 t_{WCH}
 CUMULATIVE DISTRIBUTION

By J.F. & F.N. Date 1/27/78
 V_{BB} -4.5V V_{CC} 5.0V
 LOAD N.A.
 ADDR PAT. MULTIPLE
 DATA PAT. MULTIPLE

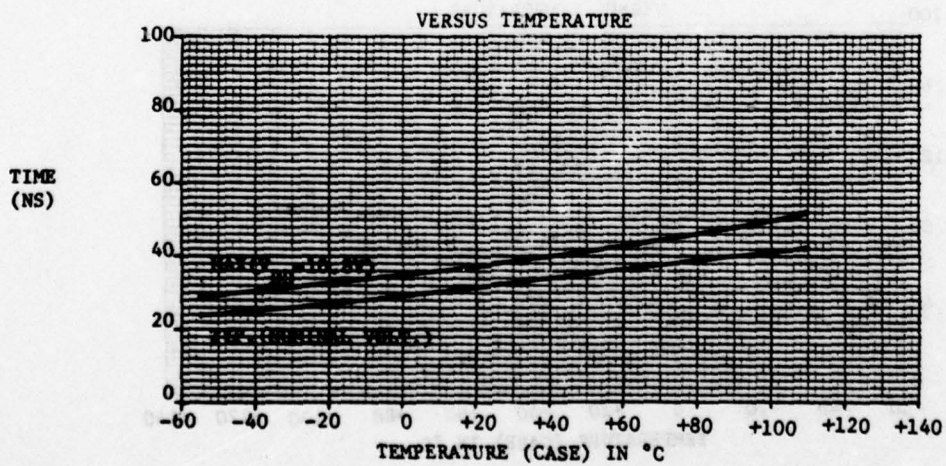
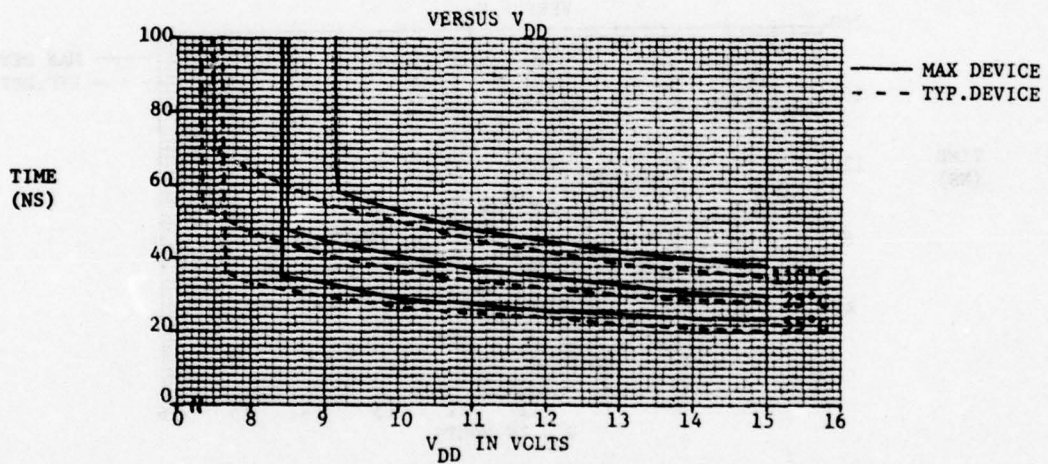
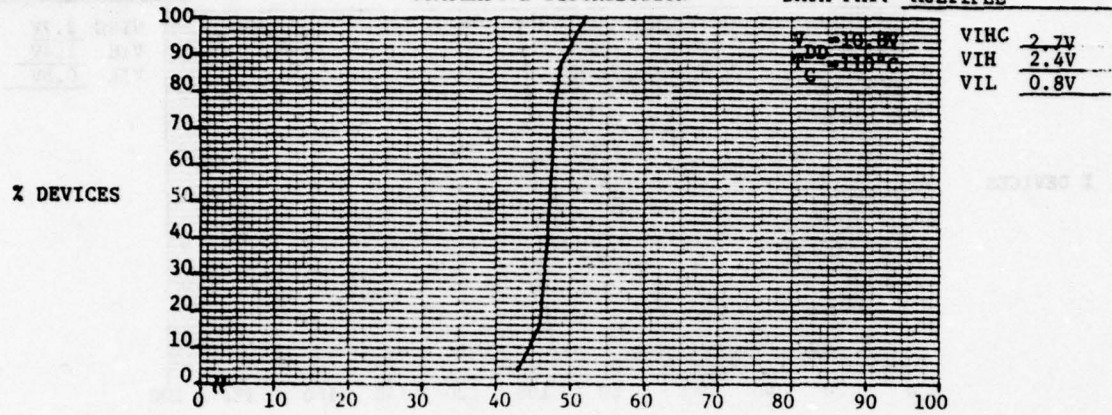

Vendor: A
 P/N: _____
 REV: G
 Date Code: 7751
 # DEVICES: 25

16K DYNAMIC RAM

WRITE COMMAND HOLD TIME TO RAS

By J.F. & F.N. Date 1/27/78
 V_{BB} -4.5V V_{CC} 5.0V
 LOAD N.A.
 ADDR PAT. MULTIPLE
 DATA PAT. MULTIPLE

t_{WCR}

W.C. CUMULATIVE DISTRIBUTION

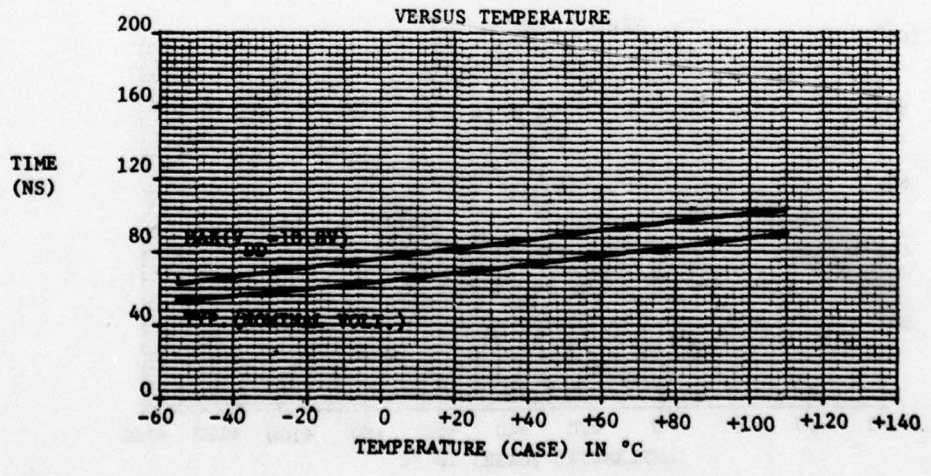
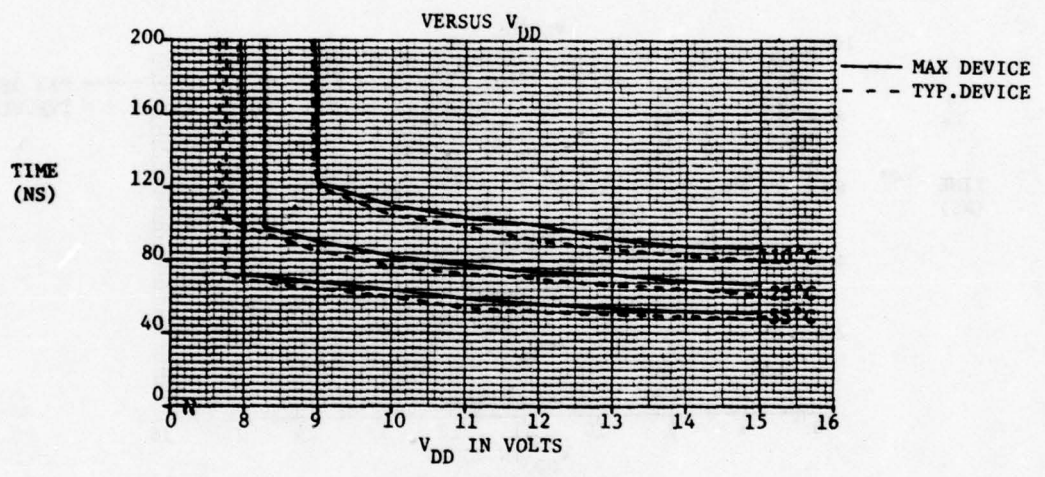
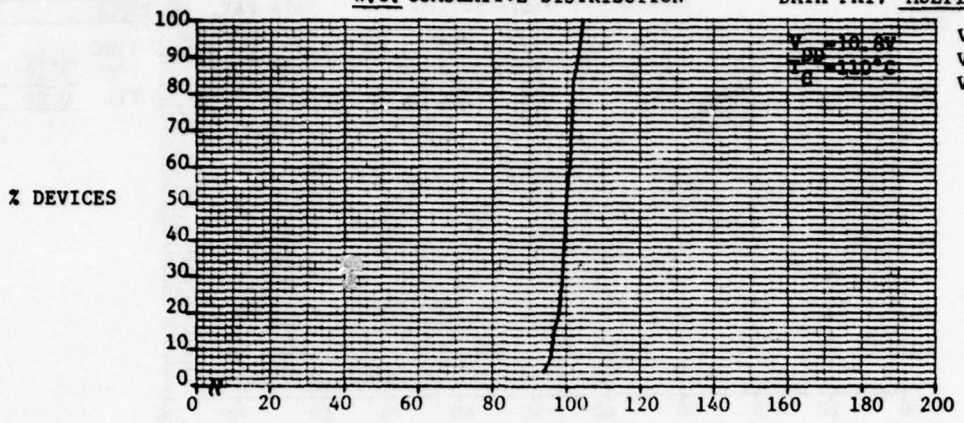

Vendor: A
 P/N: _____
 REV: G
 Date Code: 7751
 #DEVICES 25

16K DYNAMIC RAM

WRITE COMMAND PULSE WIDTH

t_{WP}

CUMULATIVE DISTRIBUTION

By F.N. & J.F. Date 2/1/78
 V_{BB} -4.5V V_{CC} 5.0V
 LOAD N.A.
 ADDR PAT. MULTIPLE
 DATA PAT. MULTIPLE

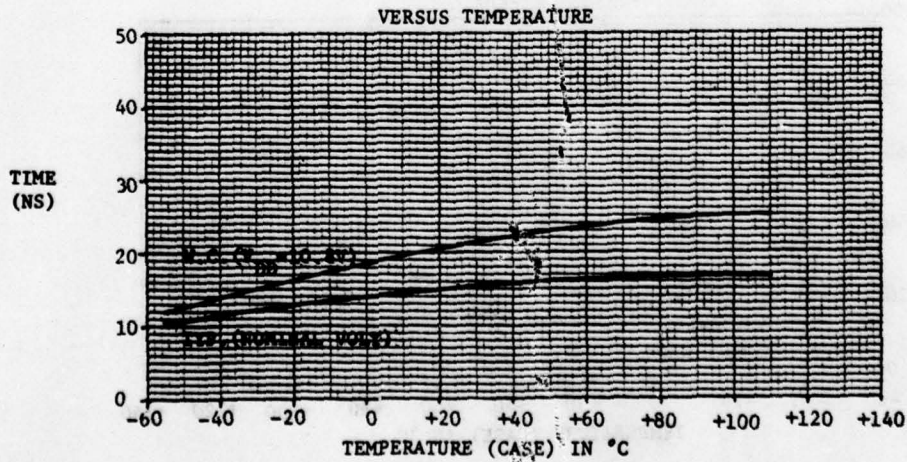
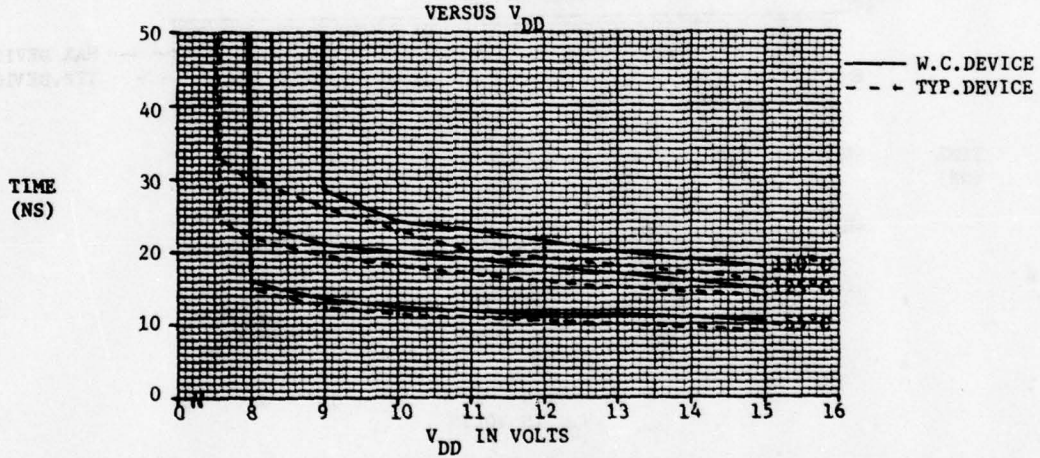
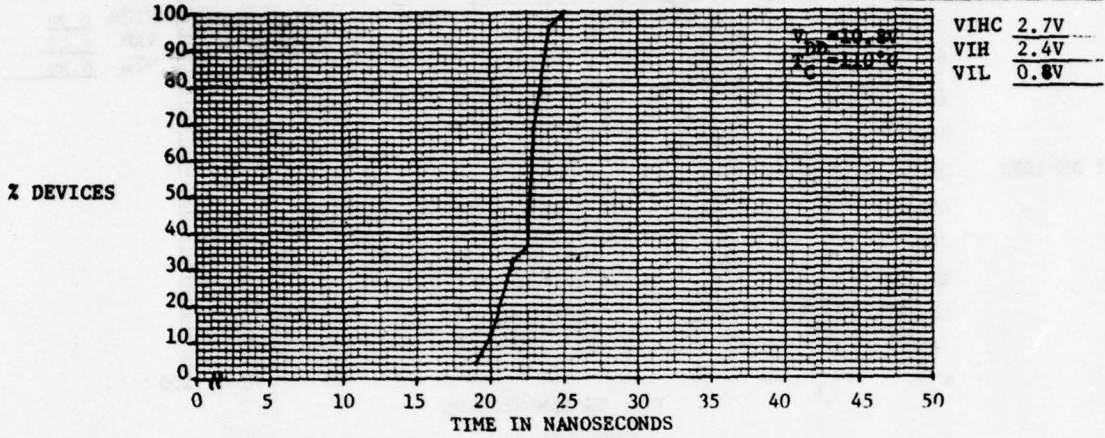

Vendor: A
 P/N: _____
 REV: G
 Date Code: 7751
 # DEVICES 25

16K DYNAMIC RAM

WRITE COMMAND TO RAS LEAD TIME

t_{RWL}

W.C. CUMULATIVE DISTRIBUTION

By J.F. & F.N. Date 1/26/78
 V_{BB} -4.5V V_{CC} 5.0V
 LOAD N.A.
 ADDR PAT. MULTIPLE
 DATA PAT. MULTIPLE

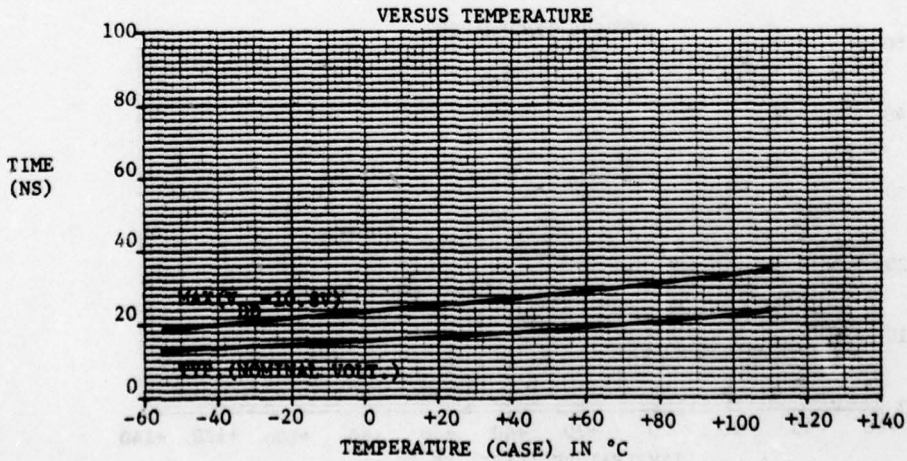
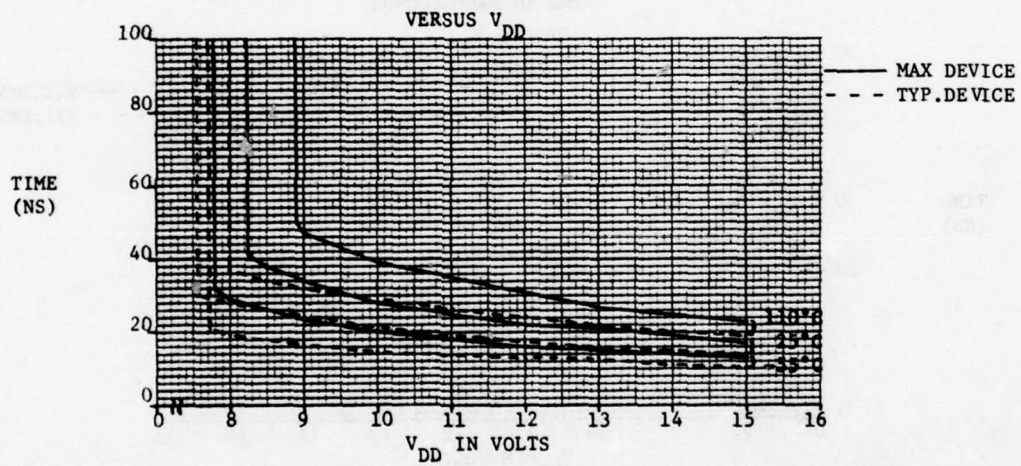
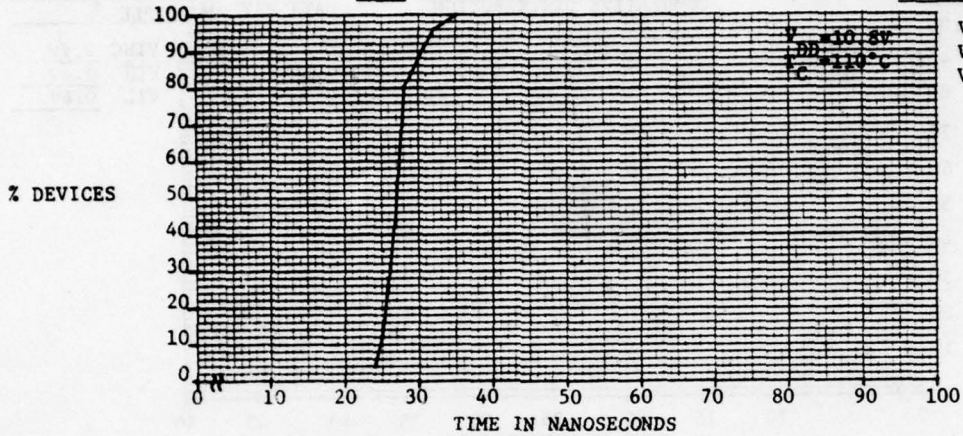

Vendor: A
 P/N: _____
 REV: G
 Date Code: 7751
 #DEVICES 25

16K DYNAMIC RAM
 WRITE COMMAND TO CAS LEAD TIME

By J.F. & F.N. Date 1/26/78
 V_{BB} -4.5V V_{CC} 5.0V
 LOAD N.A.
 ADDR PAT. MULTIPLE
 DATA PAT. MULTIPLE

t_{CWL}

W.C. CUMULATIVE DISTRIBUTION

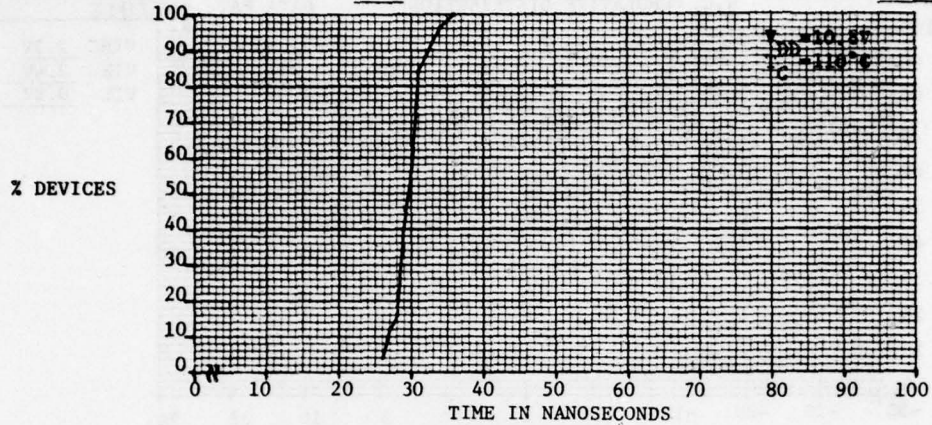

V_{IH} 2.7V
 V_{IH} 2.4V
 V_{IL} 0.8V

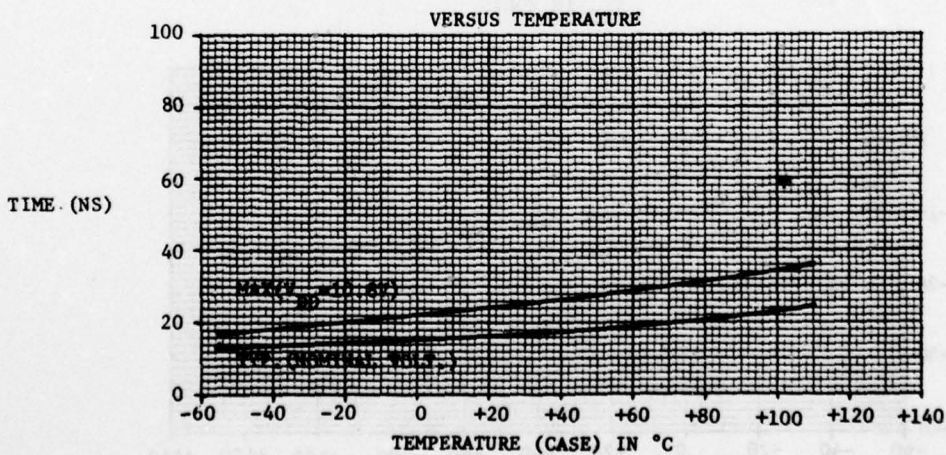
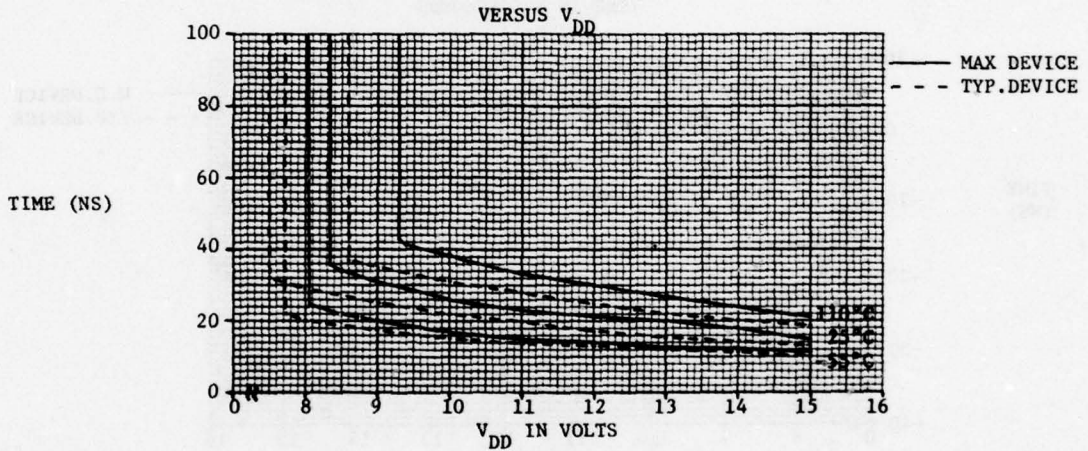

Vendor: A
 P/N: _____
 REV: G
 Date Code: 7751
 # DEVICES 25

16K DYNAMIC RAM
 DATA-IN SET-UP TIME
 REFERENCED TO CAS

By J.E. & F.N. Date 2/3/78
 V_{BB} -5.5V V_{CC} 5.0V
 LOAD N.A.
 ADDR PAT. MULTIPLE
 DATA PAT. MULTIPLE

$t_{DS}(C)$

W.C. CUMULATIVE DISTRIBUTION

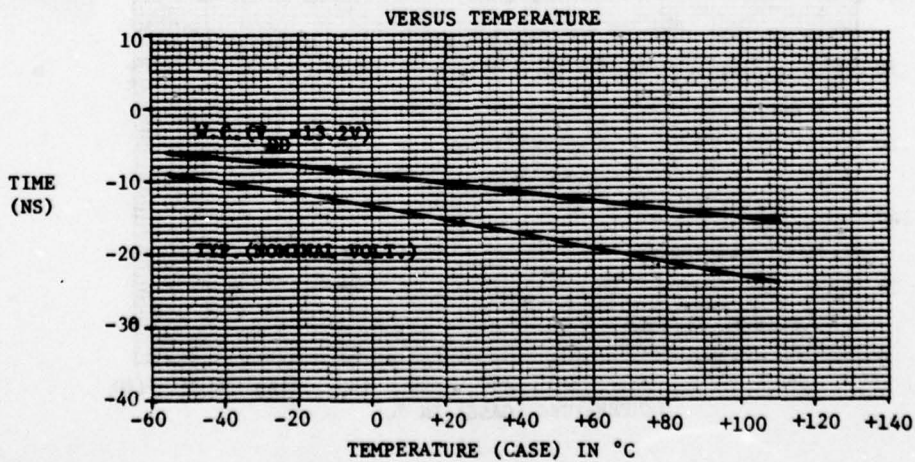
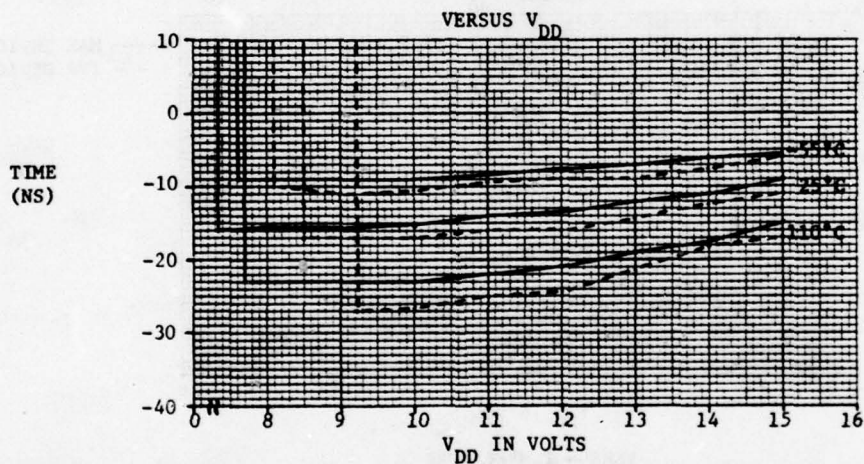
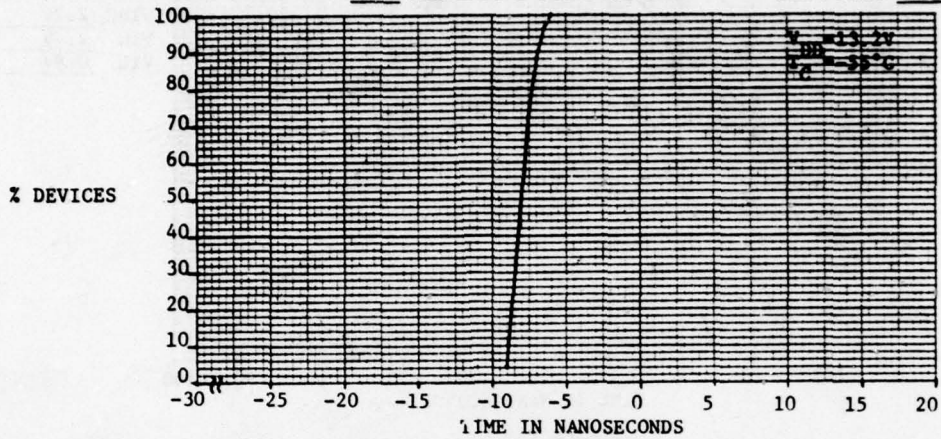

Vendor: A
 P/N: _____
 REV: G
 Date Code: 7751
 # DEVICES 25

16K DYNAMIC RAM
 DATA-IN SET-UP TIME
 REFERENCED TO WRITE

By J.F. & F.N. Date 2/1/78
 V_{BB} -4.5V V_{CC} 5.0V
 LOAD N.A.
 ADDR PAT. MULTIPLE
 DATA PAT. MULTIPLE

$t_{DS(W)}$

W.C. CUMULATIVE DISTRIBUTION

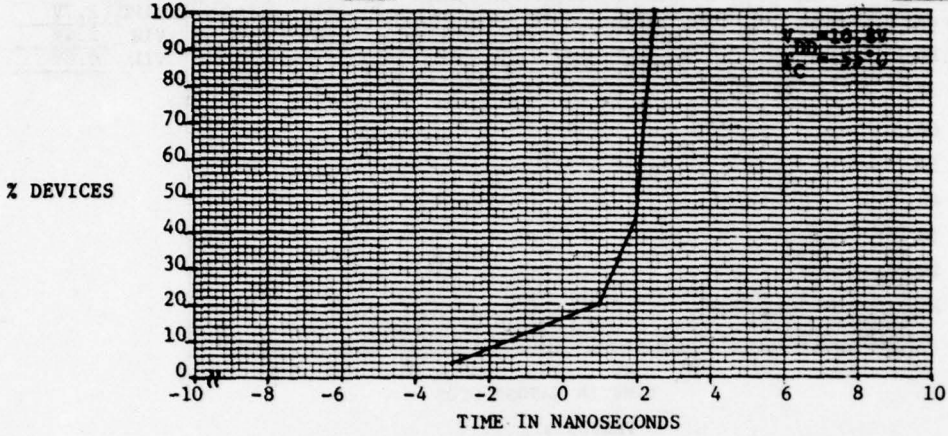

V_{BB} -4.5V V_{CC} 5.0V
 V_{IH} 2.7V
 V_{IL} 0.8V

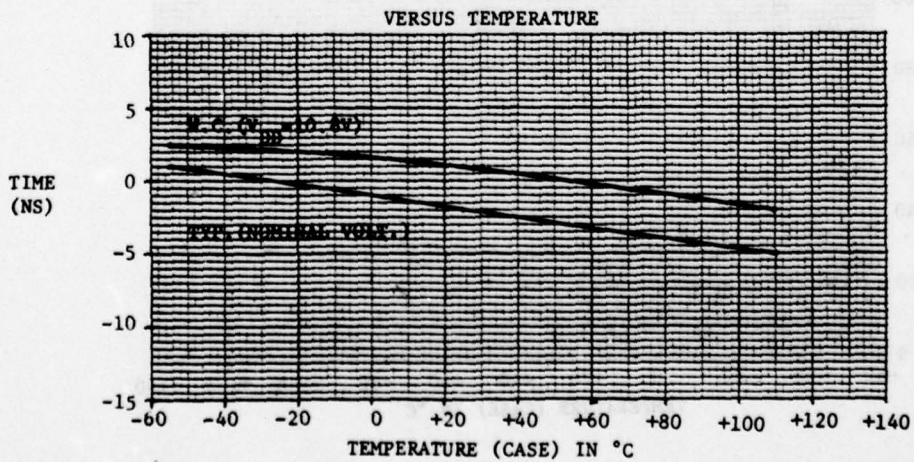
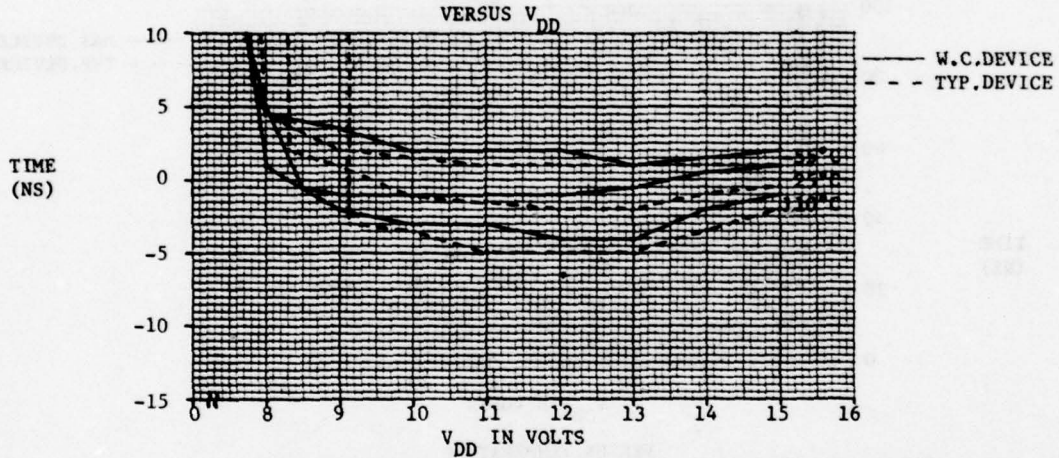

Vendor: A
 P/N: _____
 REV: G
 Date Code: 7751
 # DEVICES 25

16K DYNAMIC RAM
DATA-IN HOLD TIME
REFERENCED TO CAS

By J.F. & F.N. Date 2/2/78
 V_{BB} -4.5V V_{CC} 5.0V
 LOAD N.A.
 ADDR PAT. MULTIPLE
 DATA PAT. MULTIPLE

$t_{DH}(C)$

W.C. CUMULATIVE DISTRIBUTION

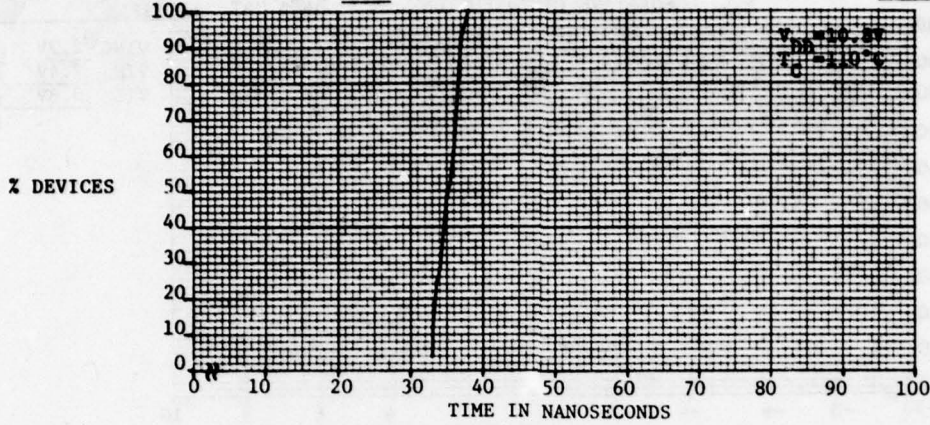

$V_{DD} = 5.0V$
 $T_C = 25^\circ C$
 V_{IHC} 2.7V
 V_{IH} 2.4V
 V_{IL} 0.8V

VERSUS V_{DD}

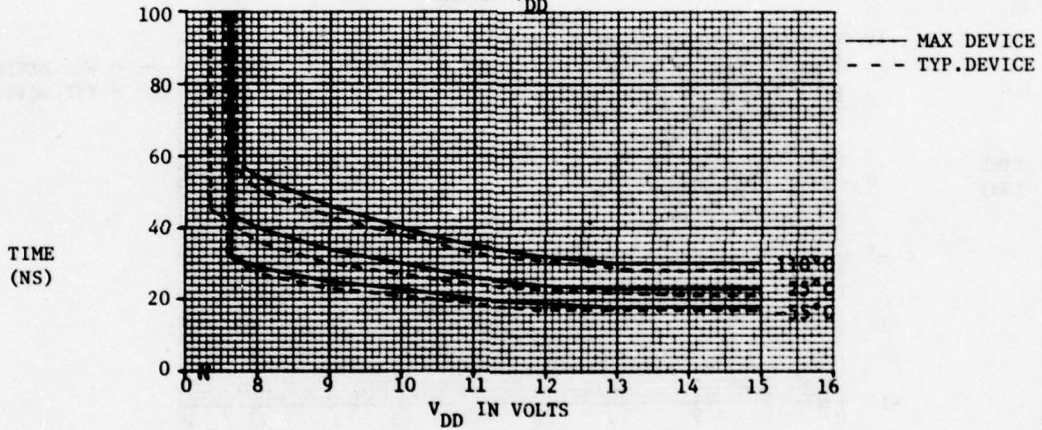

VERSUS TEMPERATURE

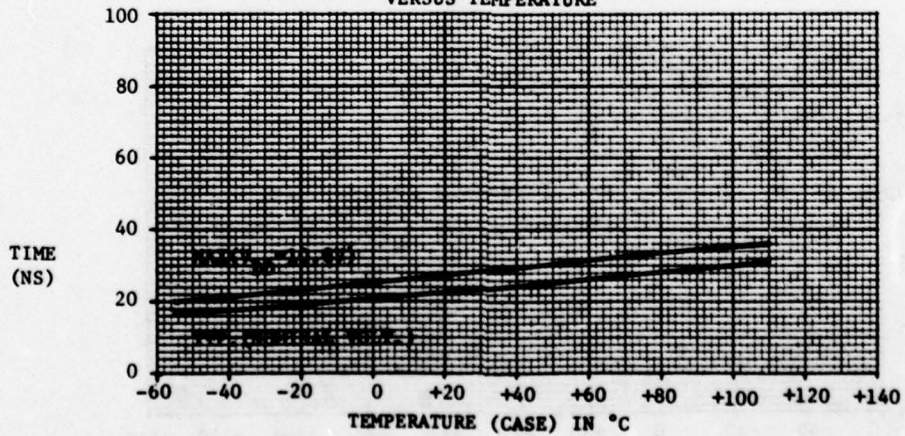

Vendor: A
 P/N: _____
 REV: G
 Date Code: 7751
 # DEVICES 25

16K DYNAMIC RAM
 DATA-IN HOLD TIME
 REFERENCED TO WRITE
 $t_{DH(W)}$

By J.F. & F.N. Date 2/2/78
 V_{BB} -4.5V V_{CC} 5.0V
 LOAD N.A.
 ADDR PAT. MULTIPLE
 DATA PAT. MULTIPLE

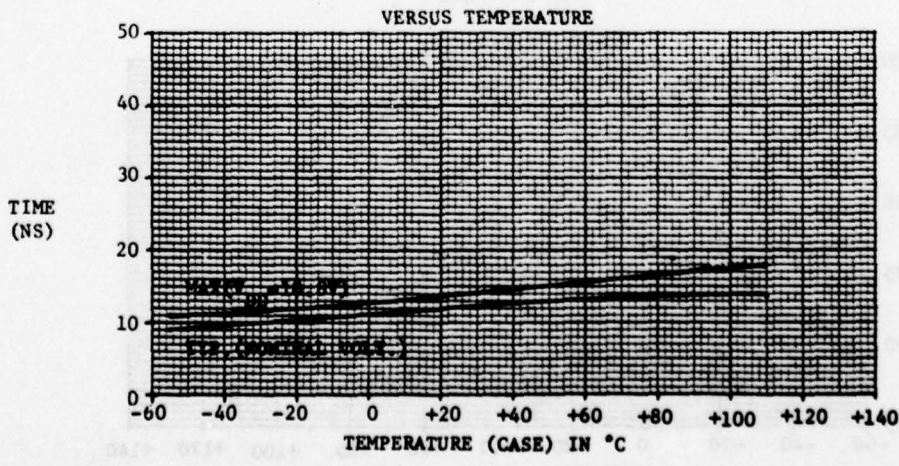
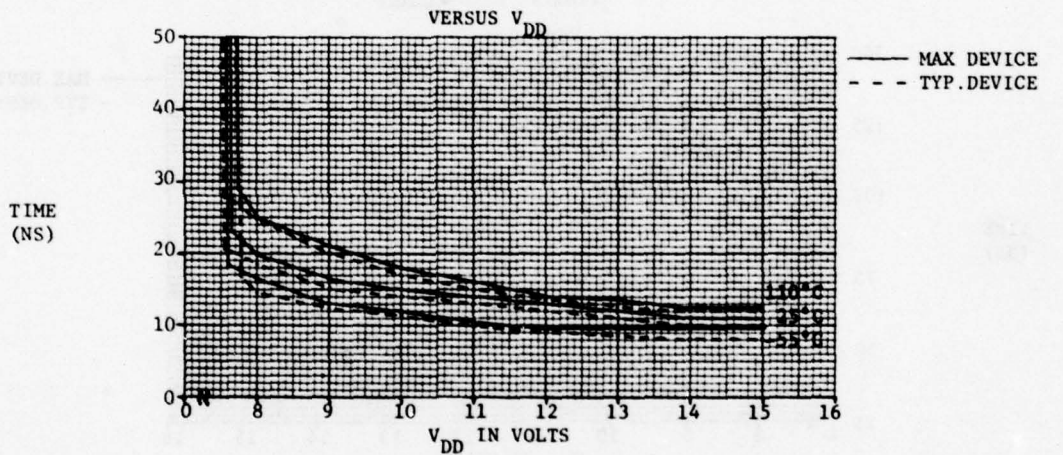
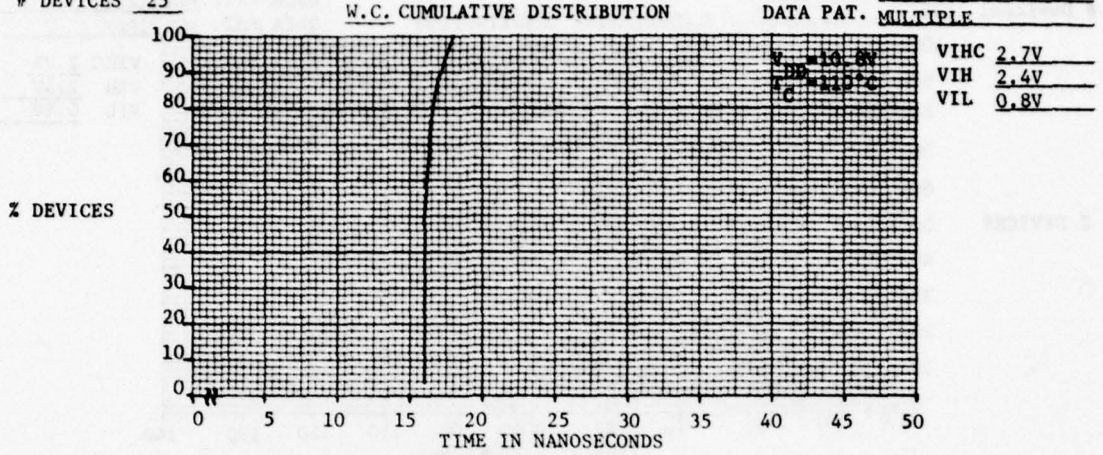

Vendor: A
 P/N:
 REV: G
 Date Code: 7751
 # Devices: 25

16K DYNAMIC RAM
DATA-IN HOLD TIME
REFERENCED TO RAS
 t_{DHR}

By J.F.&F.N. Date 2/1/78
 V_{BB} -4.5V V_{CC} 5.0V
 LOAD N.A.
 ADDR PAT. MULTIPLE
 DATA PAT. MULTIPLE

W.C. CUMULATIVE DISTRIBUTION

2 DEVICES

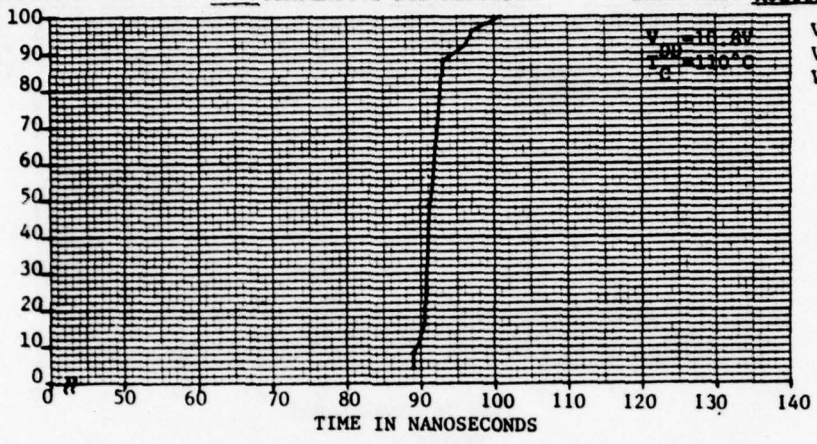

$V_{DD} = 10.0V$
 $T_{amb} = 30^{\circ}C$
 VIHC 2.7V
 VIH 2.4V
 VIL 0.8V

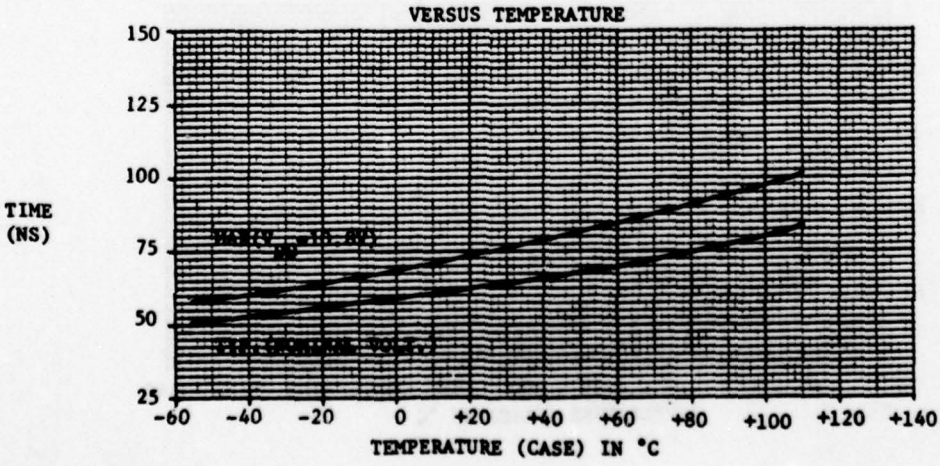
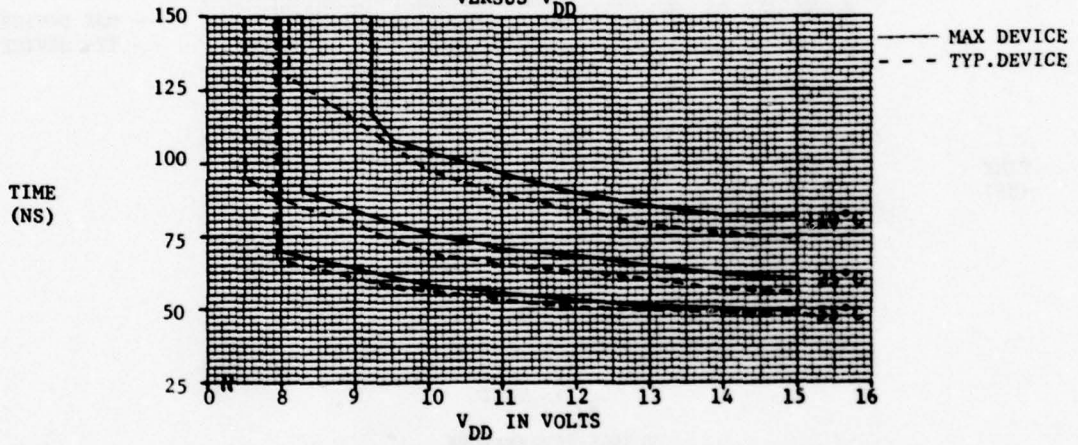

16K DYNAMIC RAM

Vendor: A
P/N: _____
REV: G
Date Code: 7751
devices 25

CELL RETENTION TIME
REFRESH PERIOD t_{REF}

By J.R.F. Date 1/12/78
 V_{DD} 10.8V V_{BB} -5.0V
ADDR. PAT. DYNAMIC REFRESH
DATA PAT. SINGLE X-BAR
 V_{IHC} 2.7V
 V_{IH} 2.4V
 V_{IL} 0.8V

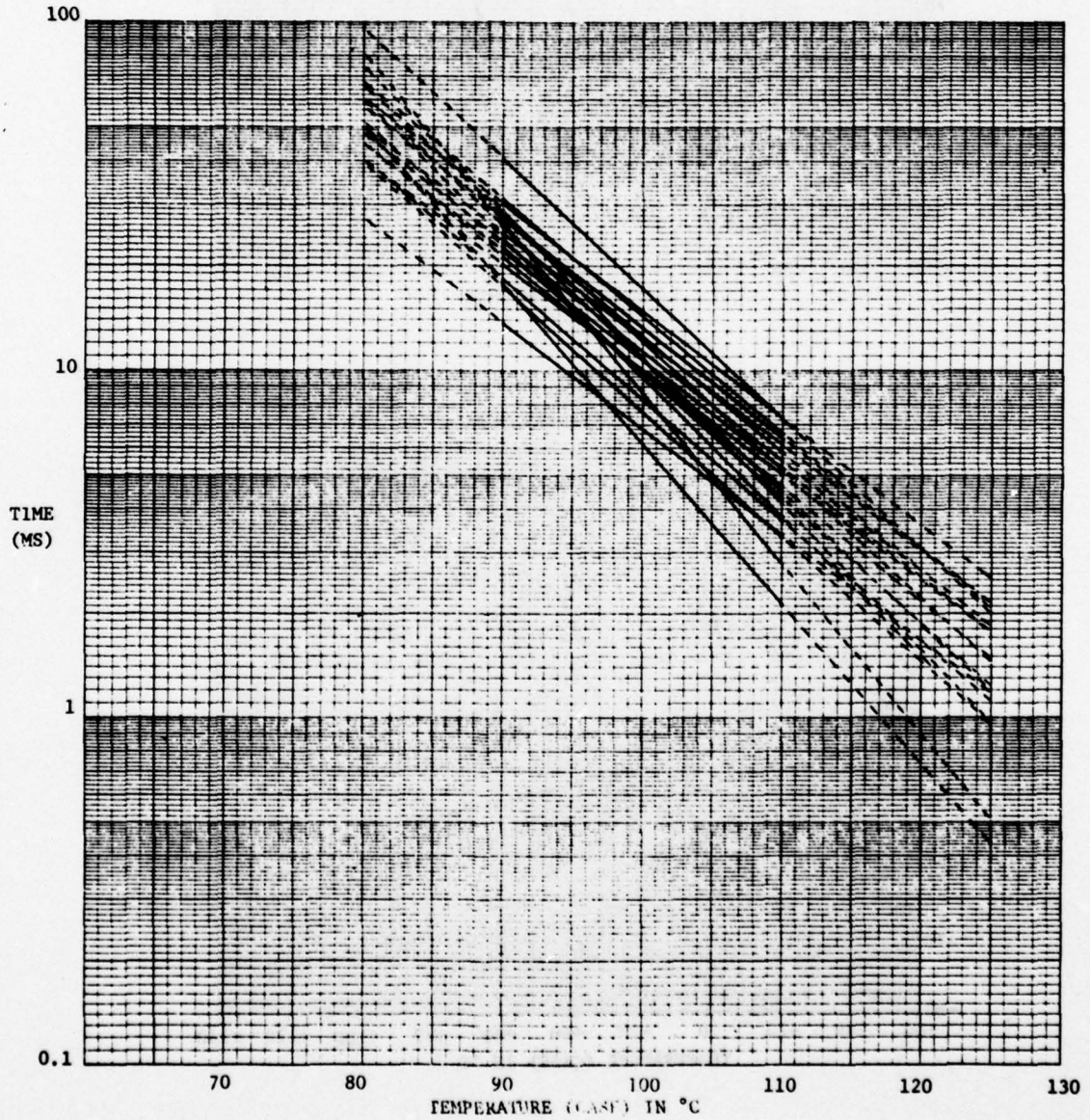

Vendor: A
 P/N: _____
 REV: G
 Date Code: 7751
 # DEVICES 25

16K DYNAMIC RAM
 WRITE COMMAND SET-UP TIME

By J.F. & F.N. Date 2/11/78
 V_{BB} -5.5V V_{CC} 5.0V
 LOAD N.A.
 ADDR PAT. MULTIPLE
 DATA PAT. MULTIPLE

t_{WCS}

W.C. CUMULATIVE DISTRIBUTION

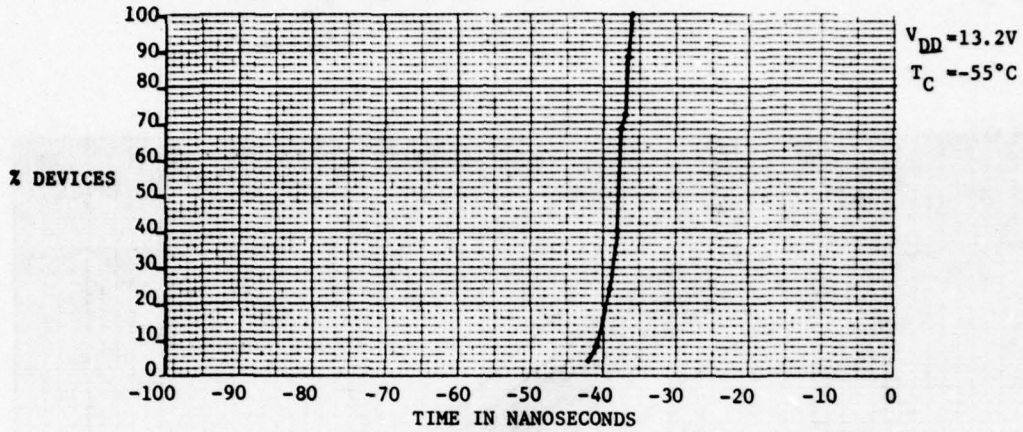

VERSUS TEMPERATURE

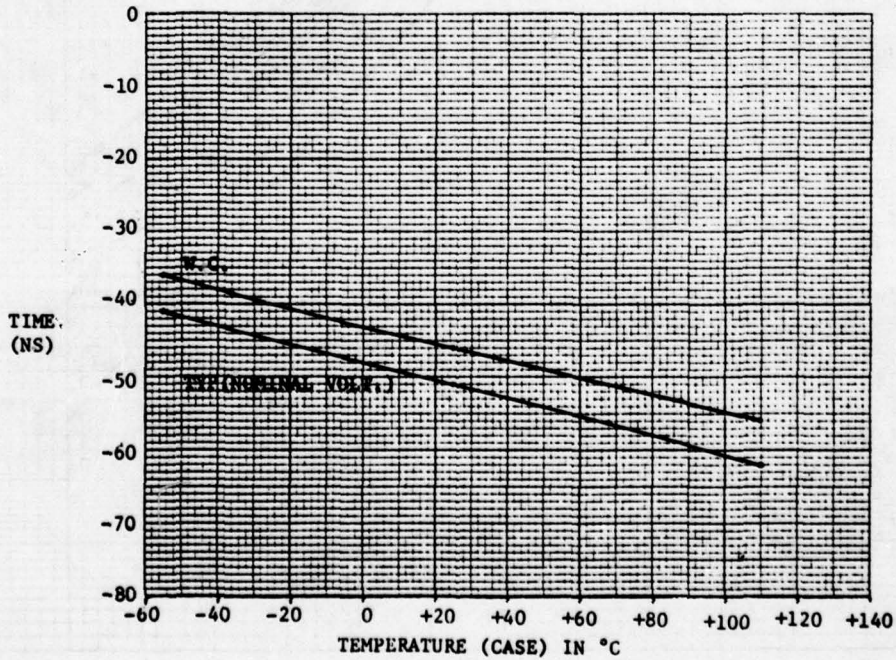

Vendor: A
P/N: _____
REV.: G
Date Code: 7751
DEVICES: 25

16K DYNAMIC RAM

By: J.F. & F.N. Date 2/10/78
LOAD N.A.
ADDR. PAT. MULTIPLE
DATA PAT. MULTIPLE

$V_{DD} = 10.8V$
 $V_{BB} = -4.5V$
 $V_{CC} = 5.0V$

$\overline{\text{CAS}}$ TO WRITE DELAY (t_{CWD})
VERSUS TEMPERATURE

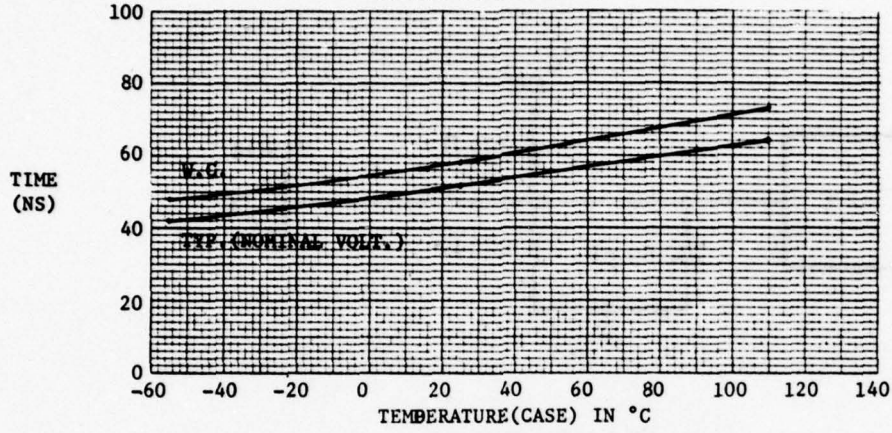

$\overline{\text{RAS}}$ TO WRITE DELAY (t_{RWD})
VERSUS TEMPERATURE

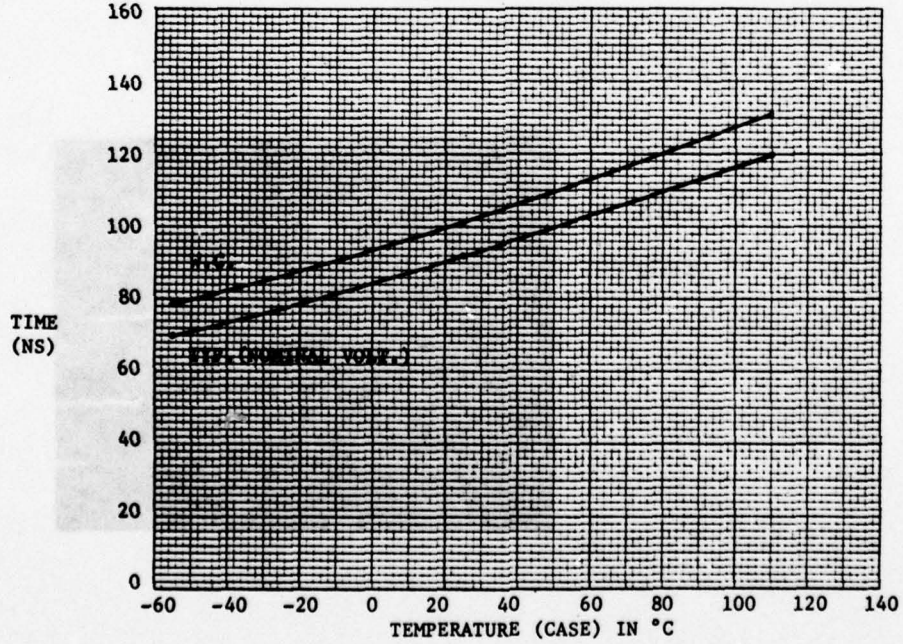

Output Turn-Off Delay
CAS Rise to Output High-Z

Measurement reference levels:
1.5 V to 10% change on output

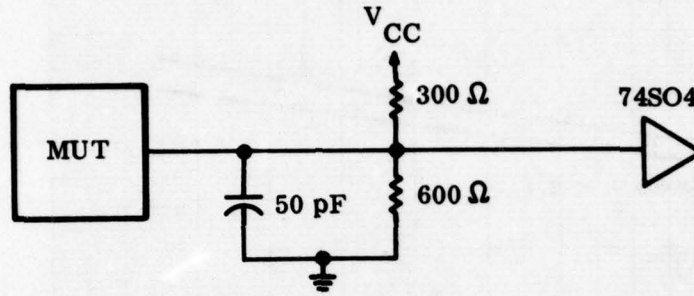

Load Configuration

CAS
Data out

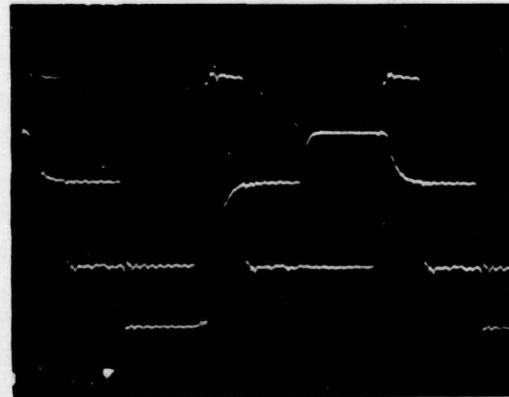

Unexpanded View, Depicting Data Out with Respect to CAS

Output Turn-Off Delay
CAS Rise to Output High-Z

Measured:

1.5 V to 10% change on output

W.C.P.S.

$V_{DD} = 13.2 \text{ V}$

$V_{BB} = -5.5 \text{ V}$

$V_{CC} = 5.0 \text{ V}$

110°C(case)

$t_{OFF} = 28 \text{ ns}$

CAS

Data out



VENDOR A

Rev G

D.C. 7751

25°C(case)

$t_{OFF} = 24 \text{ ns}$

CAS

Data out

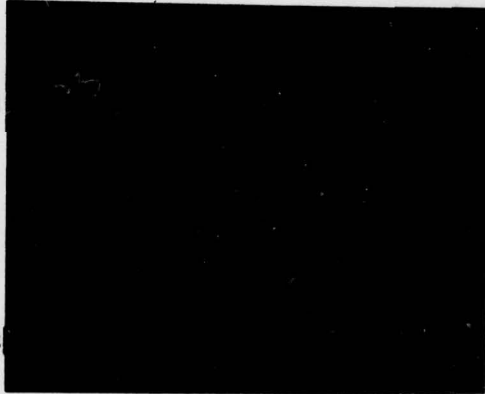

Maximum unit 10

-55°C(case)

$t_{OFF} = 19 \text{ ns}$

CAS

Data out

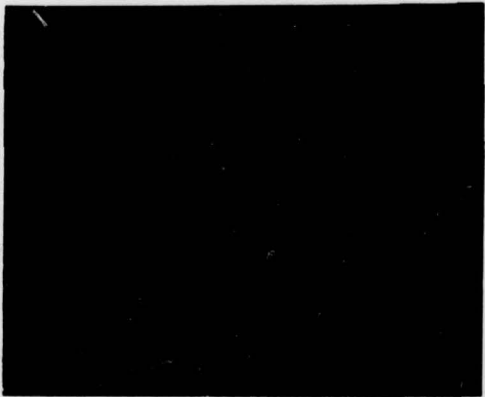

Output Turn-Off Delay
CAS Rise to Output High-Z

Measured:

1.5 V to 10% change on output

W.C.P.S.
 $V_{DD} = 13.2 \text{ V}$
 $V_{BB} = -5.5 \text{ V}$
 $V_{CC} = 5.0 \text{ V}$

110°C(case)
 $t_{OFF} = 25 \text{ ns}$

CAS

Data out

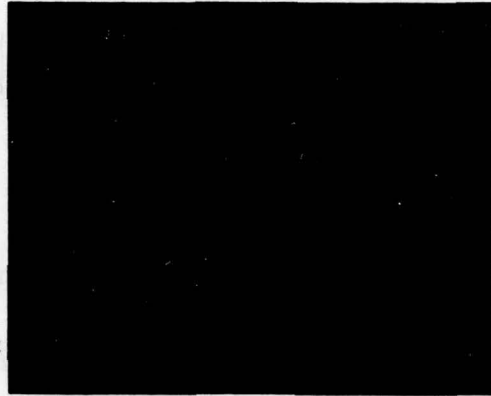

VENDOR A

Rev G
D.C. 7751

Minimum unit 24

25°C(case)
 $t_{OFF} = 21 \text{ ns}$

CAS

Data out

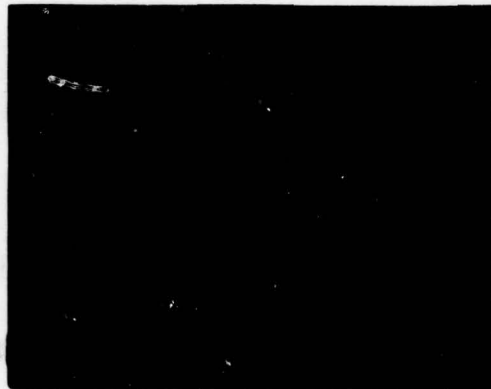

-55°C(case)
 $t_{OFF} = 16 \text{ ns}$

CAS

Data out



Output Turn-Off Delay
CAS Rise to Output High-Z

Measured:

1.5 V to 10% change on output

W.C.P.S.
 $V_{DD} = 13.2 \text{ V}$
 $V_{BB} = -5.5 \text{ V}$
 $V_{CC} = 5.0 \text{ V}$

110°C(case)
 $t_{OFF} = 27 \text{ ns}$

CAS

Data out



VENDOR A

Rev G
D.C. 7751

Typical Unit 14

25°C(case)
 $t_{OFF} = 23 \text{ ns}$

CAS

Data out



-55°C(case)
 $t_{OFF} = 19 \text{ ns}$

CAS

Data out

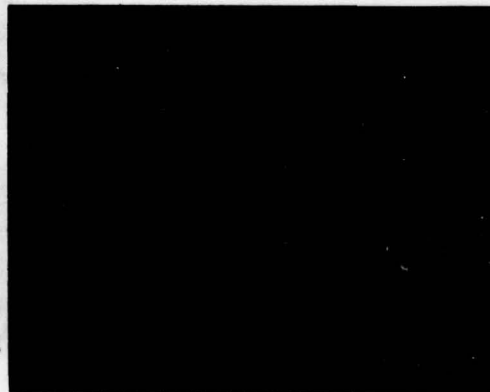

Output Turn-Off Delay
CAS Rise to Output High-Z

Measured:

1.5 V to 10% change on output

W.C.P.S.

$V_{DD} = 13.2 \text{ V}$
 $V_{BB} = -5.5 \text{ V}$
 $V_{CC} = 5.0 \text{ V}$

Data Out

110°C (case)
 $t_{OFF} = 30 \text{ ns}$

CAS



VENDOR A

Rev G
D.C. 7751

Maximum unit 10

Data out

25°C (case)
 $t_{OFF} = 25 \text{ ns}$

CAS

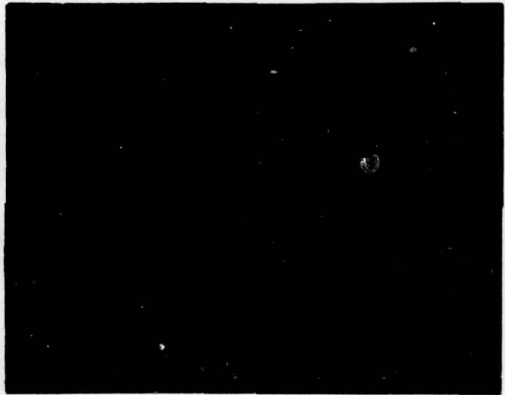

Data out

-55°C (case)
 $t_{OFF} = 22 \text{ ns}$

CAS



Output Turn-Off Delay
CAS Rise to Output High-Z

Measured:

1.5 V to 10% change on output

W.C.P.S.
 $V_{DD} = 13.2 \text{ V}$
 $V_{BB} = -5.5 \text{ V}$
 $V_{CC} = 5.0 \text{ V}$

Data out

110°C(case)
 $t_{OFF} = 28 \text{ ns}$

CAS



VENDOR A

Rev G
D.C. 7751

Typical unit 14

Data out

25°C(case)
 $t_{OFF} = 25 \text{ ns}$

CAS



Data out

-55°C(case)
 $t_{OFF} = 21 \text{ ns}$

CAS

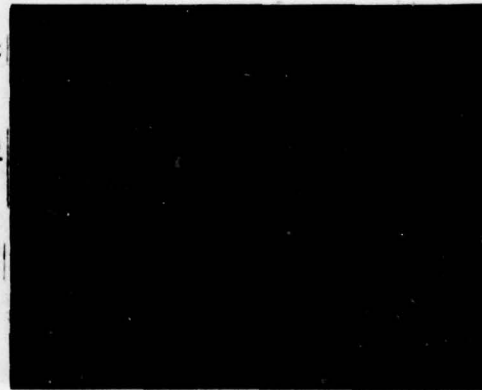

Output Turn-Off Delay
CAS Rise to Output High-Z

Measured:

1.5 V to 10% change on output

W.C.P.S.
 $V_{DD} = 13.2 \text{ V}$
 $V_{BB} = -5.5 \text{ V}$
 $V_{CC} = 5.0 \text{ V}$

Data out

110°C(case)
 $t_{OFF} = 26 \text{ ns}$

CAS



VENDOR A

Rev G
D.C. 7751

Minimum unit 24

Data out

25°C(case)
 $t_{OFF} = 23 \text{ ns}$

CAS



Data out

-55°C(case)
 $t_{OFF} = 18 \text{ ns}$

CAS

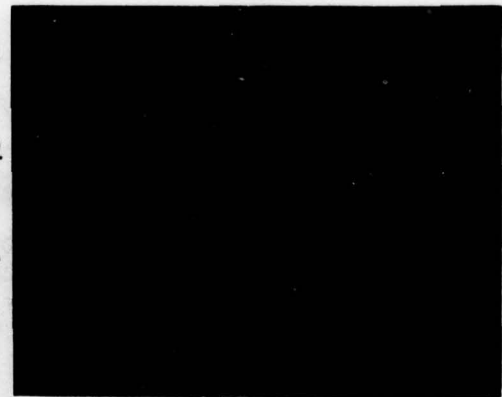

16K DYNAMIC RAM
DEVICE CAPACITANCE

VENDOR A

REV.G
D.C. 7751

Device input and output capacitance measurements were made using a BOONTON Model 75B-S8 capacitance bridge. This bridge uses a test frequency of 1.0 MHZ. The test signal amplitude was set at 20MV P-P.

Measurements were made with nominal voltages applied, and taken under biased conditions. Increasing bias from 0V to 2.4V or 2.7V in the case of the clock inputs, increases capacitance by 1.0 to 1.5 pF. The WORSE CASE reading for each input and the data output pin are recorded below.

| | | |
|--------|----------------------|----------|
| PIN 2 | \overline{D}_{IN} | = 2.1 pF |
| PIN 3 | \overline{WRITE} | = 3.5 pF |
| PIN 4 | \overline{RAS} | = 4.0 pF |
| PIN 5 | A_0 | = 2.0 pF |
| PIN 6 | A_2 | = 1.8 pF |
| PIN 7 | A_1 | = 1.9 pF |
| PIN 10 | A_5 | = 2.0 pF |
| PIN 11 | A_4 | = 1.9 pF |
| PIN 12 | A_3 | = 2.1 pF |
| PIN 13 | A_6 | = 2.2 pF |
| PIN 14 | \overline{D}_{OUT} | = 2.8 pF |
| PIN 15 | \overline{CAS} | = 4.3 pF |

16K DYNAMIC RAM

DYNAMIC TEST SET-UP FOR OUTPUT CURRENT

SOURCE CURRENT (I_{OH})

SINK CURRENT (I_{OL})

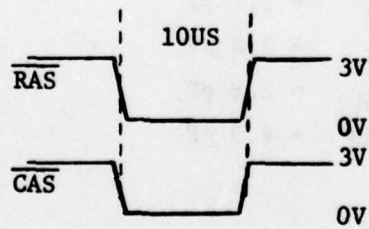
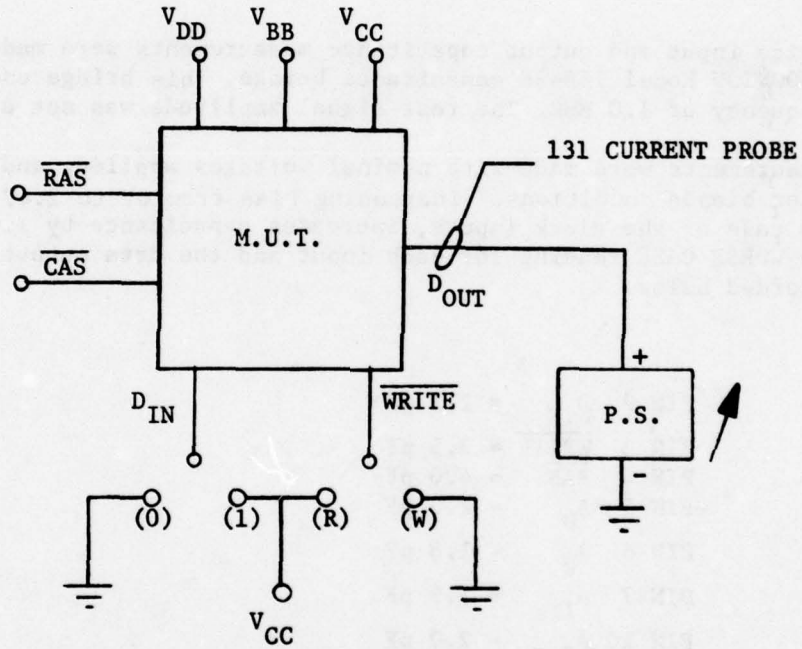

16K DYNAMIC RAM

Vendor: A
P/N: _____
REV.: G
Date Code: 7751
DEV.: 23

SOURCE CURRENT (I_{OH})

By: F.A.N.
Date: 2/15/78

V_{DD} = 10.8V
 V_{BB} = -5.5V
 V_{CC} = 5.0V

• 25°C
○ 110°C
△ -55°C

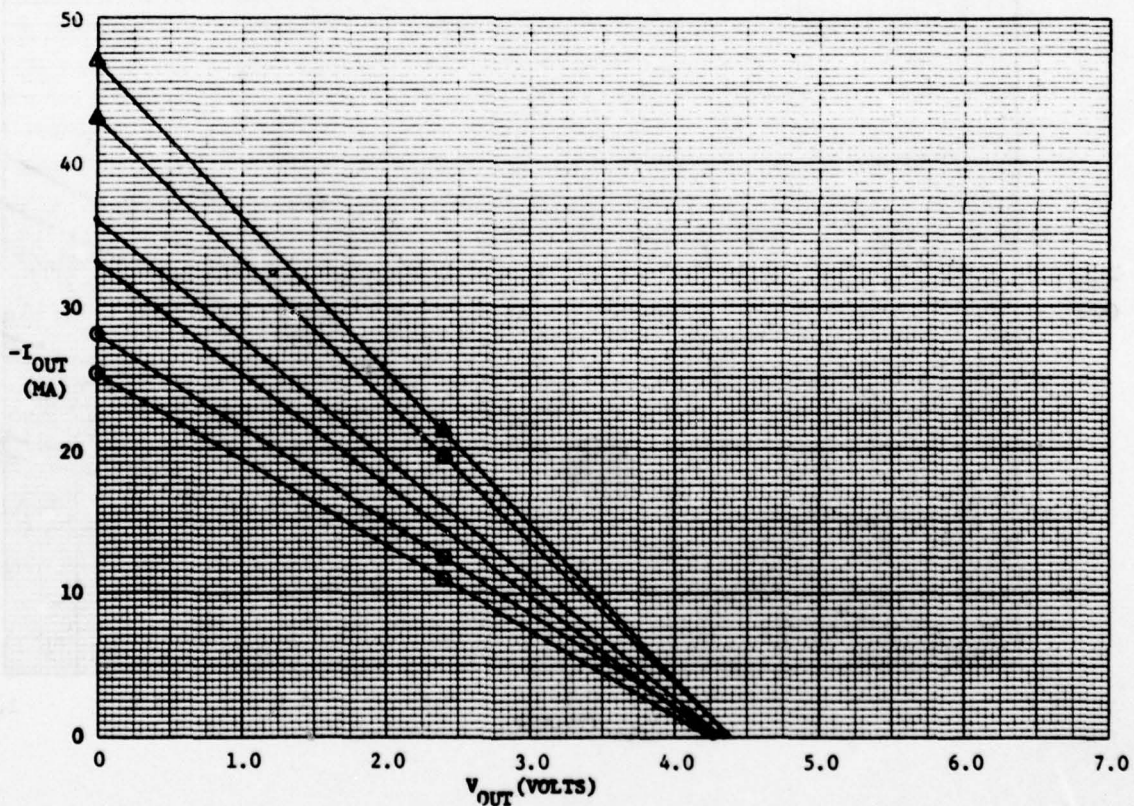

15K DYNAMIC RAM

Vendor: A
P/N: _____
REV.: G
Date Code: 7751
DEV.: 23

SINK CURRENT (I_{OL})

By: F.A.N.
Date: 2/15/78

$V_{DD} = 10.8V$
 $V_{BB} = -5.5V$
 $V_{CC} = 5.0V$

• 25°C
⊙ 110°C
△ -55°C

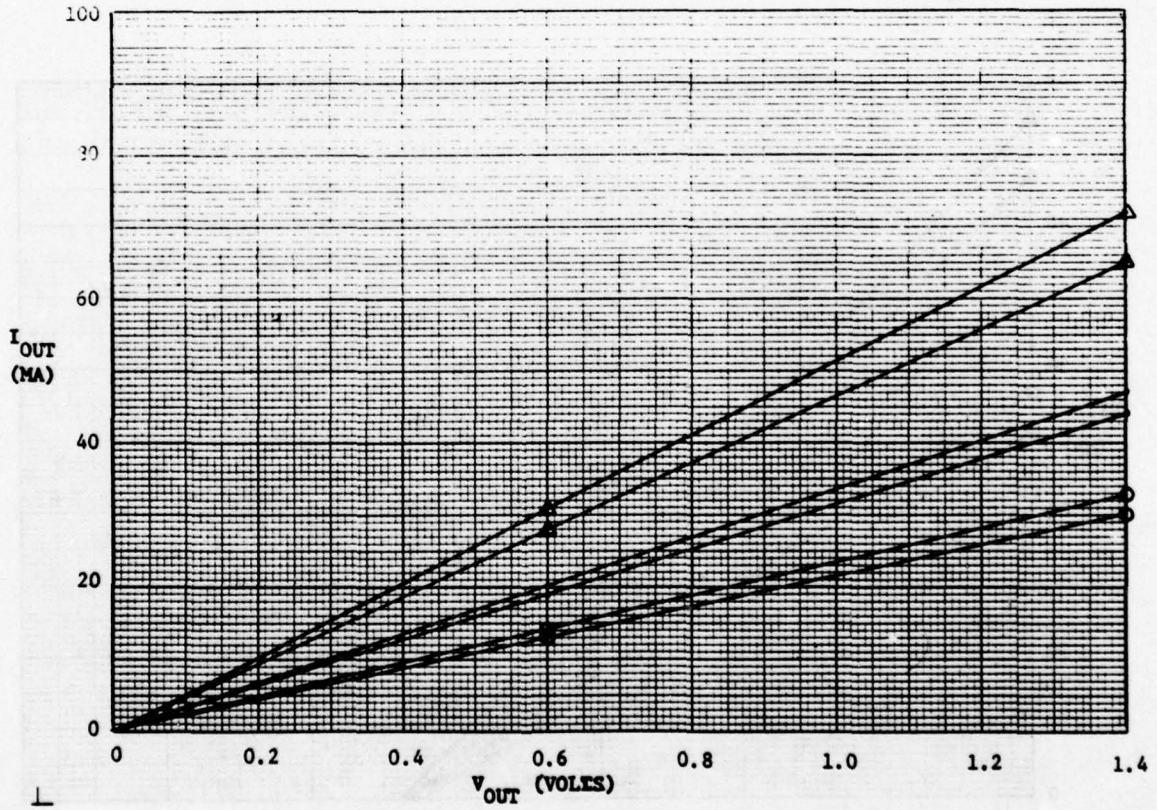

IBM

Vendor: A
P/N: _____
REV: G
Date Code: 7751
DEVICES 25

16K DYNAMIC RAM
MINIMUM INPUT UP LEVEL
(ANY INPUT)
VIH

By J.F. & F.N. Date 2/9/78
 V_{BB} -5.5V V_{CC} 5.0V
LOAD N.A.
ADDR PAT. MULTIPLE
DATA PAT. MULTIPLE

DATA BASED ON ADDR. INP. (W.C.)
W.C. CUMULATIVE DISTRIBUTION

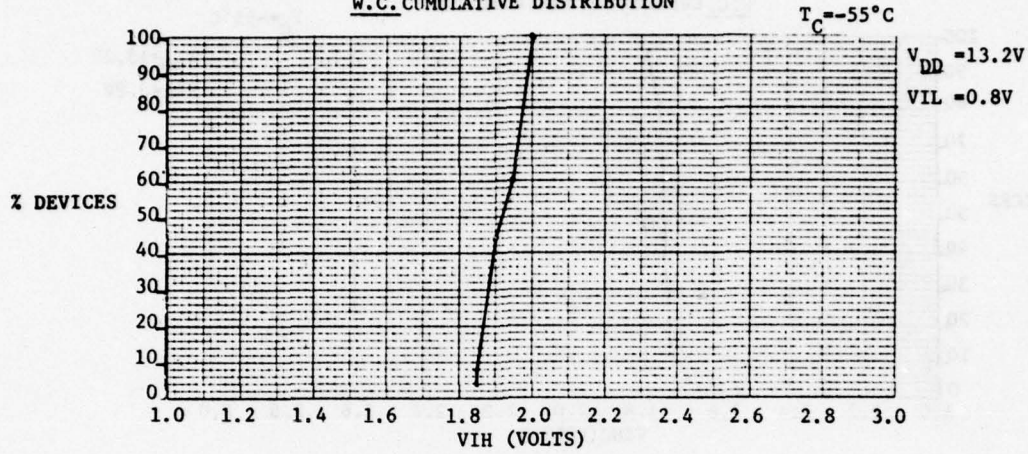

VERSUS TEMPERATURE

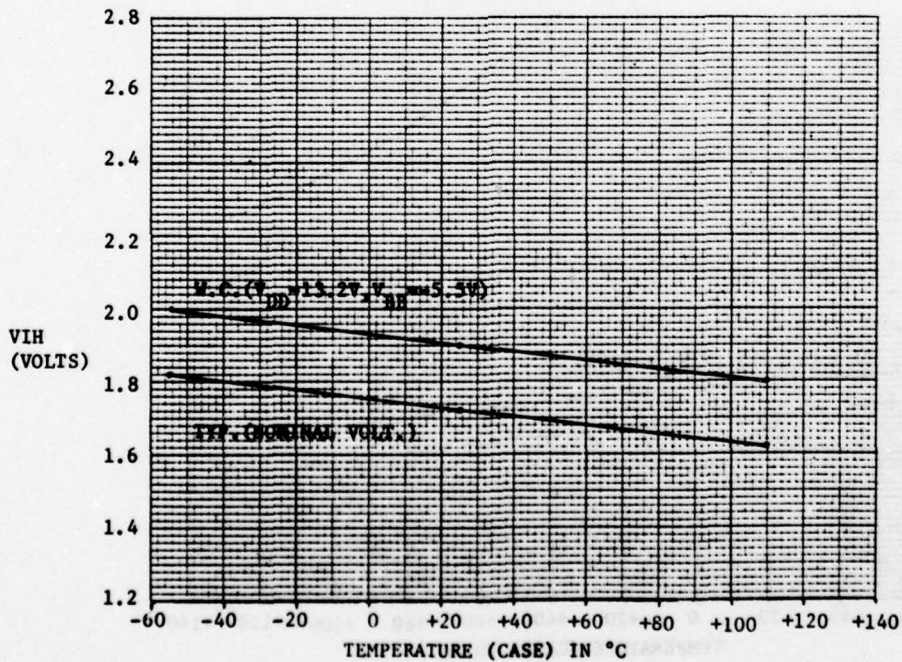

IBM Vendor: A
 P/N: _____
 REV: G
 Date Code: 7751
 # DEVICES 25

16K DYNAMIC RAM
 MINIMUM CLOCK INPUT UP LEVEL
 (ANY CLOCK)

By J.F. & F.N. Date 1/9/78
 V_{IBB} -5.5V V_{CC} 5.0V
 LOAD N.A.
 ADDR PAT. MULTIPLE
 DATA PAT. MULTIPLE

VIHC
 DATA BASED ON RAS INPUT (W.C.)

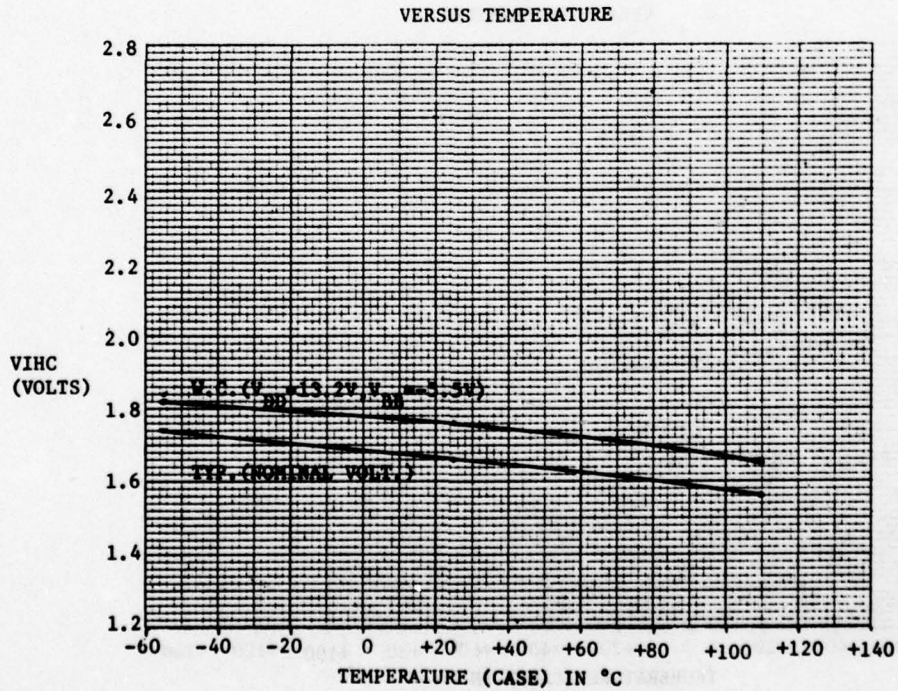
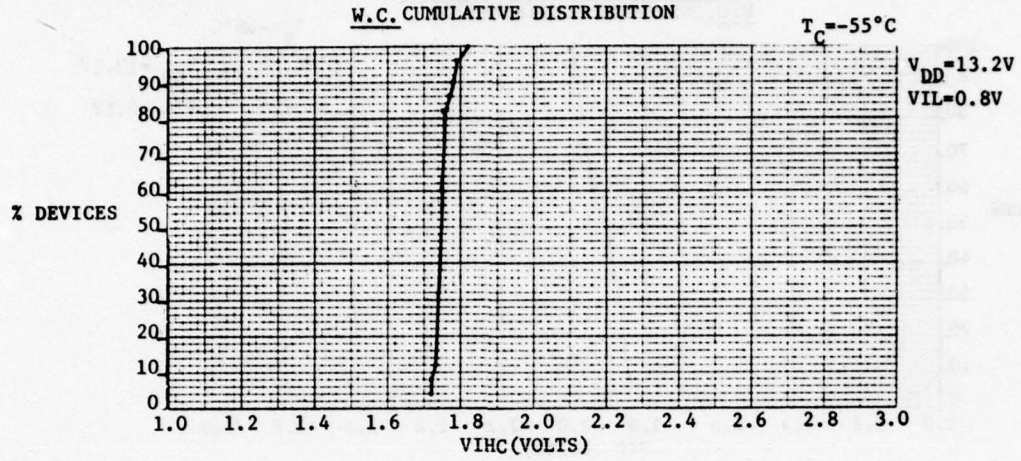

Vendor: A
 P/N: _____
 REV: G
 Date Code: 7751
 # DEVICES 25

16K DYNAMIC RAM
 MAXIMUM INPUT DOWN LEVEL
 (ANY INPUT)
 VIL

By J.F. & F.N. Date 2/8/78
 V_{BB} -4.5V V_{CC} 5.0V
 LOAD N.A.
 ADDR PAT. MULTIPLE
 DATA PAT. MULTIPLE

DATA BASED ON \overline{RAS} INPUT (W.C.)
 W.C. CUMULATIVE DISTRIBUTION

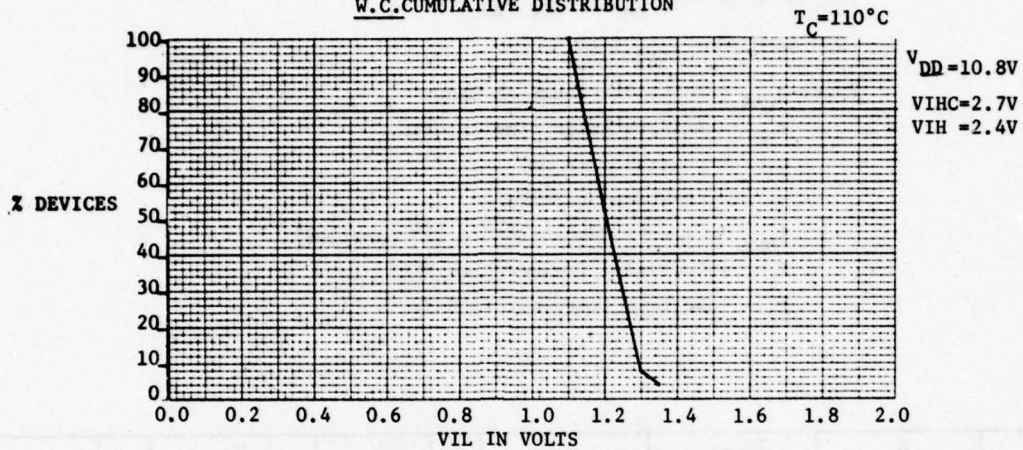

VERSUS TEMPERATURE

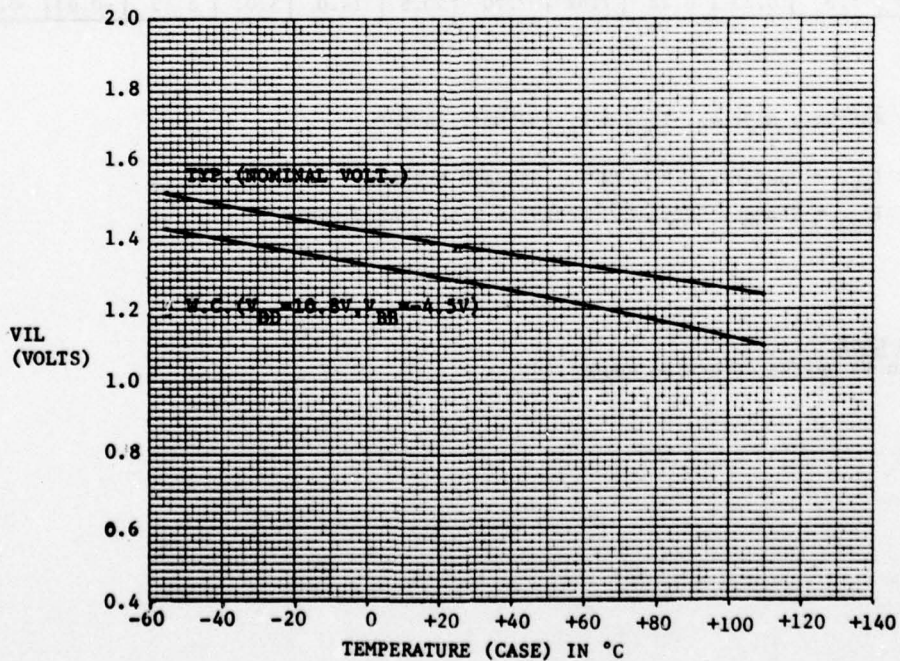

POWER CALCULATION CHART

$$I_{DD1} \text{ OPERATE} = (a t_{RAS} + I_{DD2} t_{RP} + b) F_1$$

$$I_{DD3} \text{ REFRESH} = I_{DD2} + cF_2$$

Where t_{RAS} = \overline{RAS} pulse width in USEC.

t_{RP} = \overline{RAS} precharge time in USEC.

a, b = constants in MA.

c = constant in MA/MHZ.

I_{DD2} = Standby Current (\overline{RAS} & \overline{CAS} inactive)

F_1 = Operating frequency in MHZ.

F_2 = Refresh frequency in MHZ.

| TEMP. | a | | I_{DD2} | | b | | I_{DD3}^* | | c | | $I_{BB1\&3}$ | |
|--------|------|-----|-----------|------|------|------|-------------|------|------|------|--------------|--------|
| | TYP. | MAX | TYP. | MAX | TYP. | MAX | TYP. | MAX | TYP. | MAX | TYP. | MAX |
| -55°C | 5.20 | 6.0 | 0.47 | 0.54 | 7.47 | 7.95 | 15.3 | 15.8 | 5.57 | 5.72 | -0.10 | -0.13 |
| +25°C | 3.24 | 3.8 | 0.33 | 0.54 | 7.47 | 7.67 | 14.3 | 14.7 | 5.23 | 5.36 | -0.05 | -0.06 |
| +110°C | 2.02 | 2.3 | 0.23 | 0.28 | 7.42 | 7.70 | 13.6 | 14.0 | 5.02 | 5.15 | -0.03 | -0.035 |

* \overline{RAS} -Only Refresh, I_{DD3} @ $t_{RC}=375NS(2.667MHZ.)$

I_{BB1} = Operating (2.667MHZ.) SUBRATE CURRENT.

I_{BB2} = Standby SUBTRATE CURRENT = 1.5UA MAX @ -55°C

TEMPERATURE IS CASE

CURRENTS are in MA unless otherwise specified.

IBM

Vendor: A
P/N: _____
REV: G
Date Code: 7751
25 Units

16K DYNAMIC RAM

OPERATING CURRENT

I_{DD1}

By J.R.F. Date 1/4/78
 V_{BB} -5.0V V_{CC} +5.0V
LOAD 1 SCHOTTKY TTL + 50 pFd
ADDR PAT. WALKING DIAGONAL
DATA PAT. MAJOR DIAGONAL

CUMULATIVE DISTRIBUTION

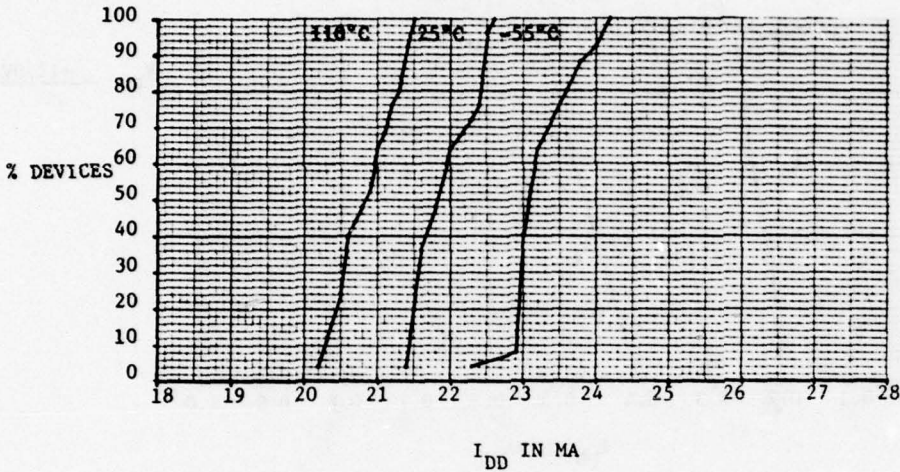

VERSUS TEMPERATURE

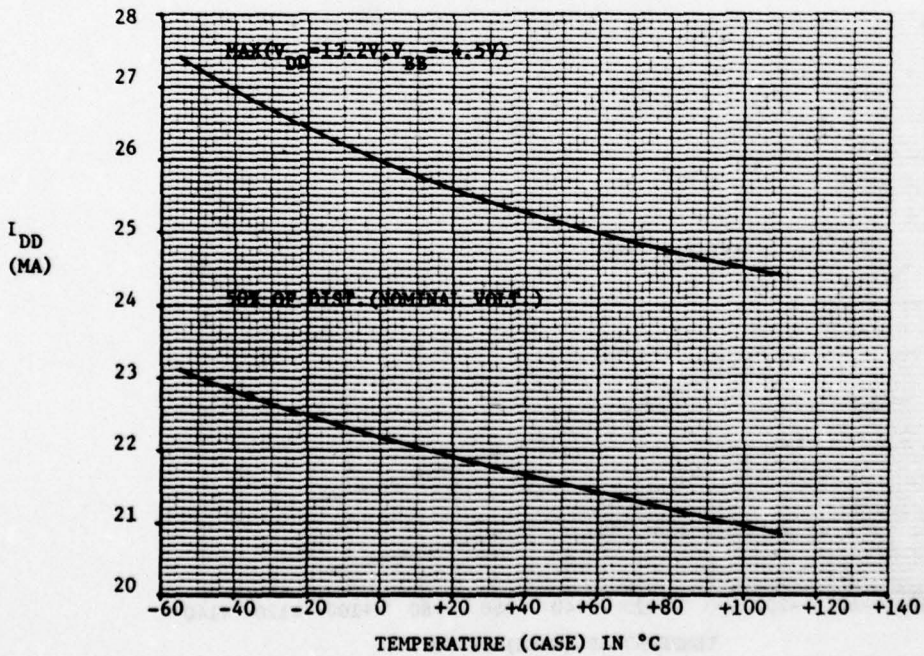

IBM

Vendor: A
 P/N: _____
 REV: C
 Date Code: 7751
 25 Units

16K DYNAMIC RAM
 STANDBY CURRENT
 RAS & CAS INACTIVE
 (HIGH)

By J.R.F. Date 1/4/78
 V_{BB} -5.0V V_{CC} +5.0V
 LOAD N/A
 ADDR PAT. N/A
 DATA PAT. N/A

I_{DD2}
 CUMULATIVE DISTRIBUTION

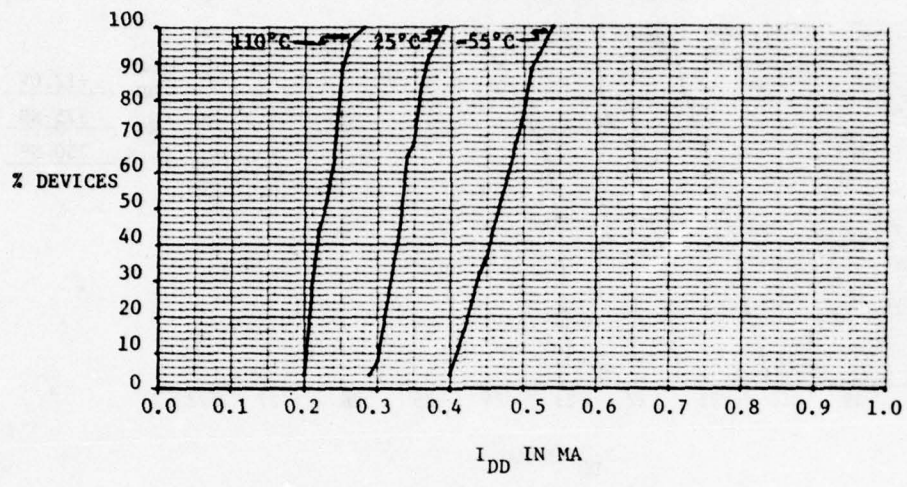

VERSUS TEMPERATURE

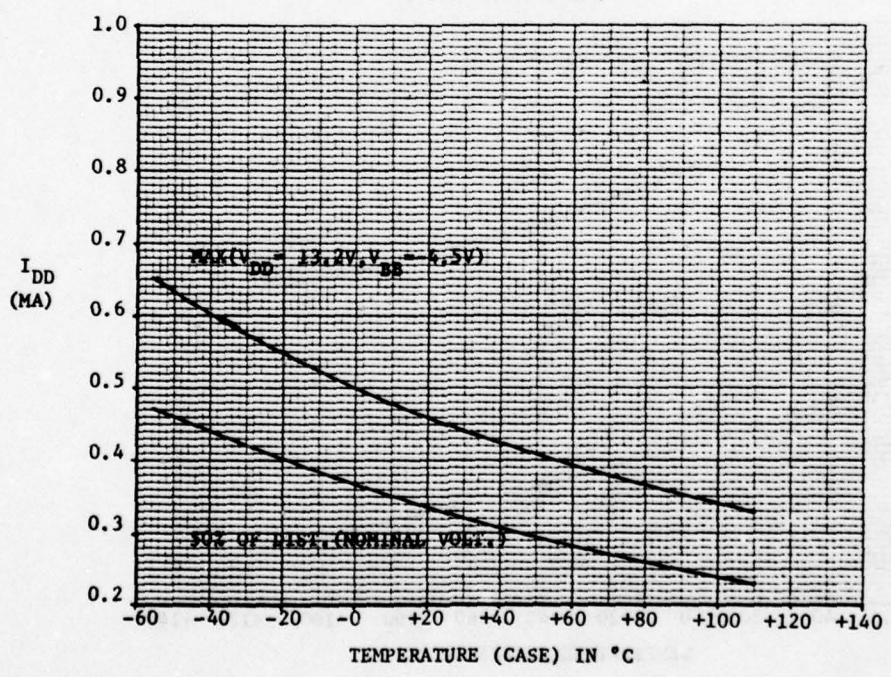

IBM Vendor: A
 P/N: _____
 REV: G
 Date Code: 7751
 25 Units

16K DYNAMIC RAM
 OPERATING CURRENT

I_{BB1}

By J.R.F. Date 1/5/78
 V_{BB} -5.0V V_{CC} +5.0V
 LOAD 1 SCHOTTKY TTL + 50 pFd
 ADDR PAT. WALKING DIAGONAL
 DATA PAT. MAJOR DIAGONAL "1"

CUMULATIVE DISTRIBUTION

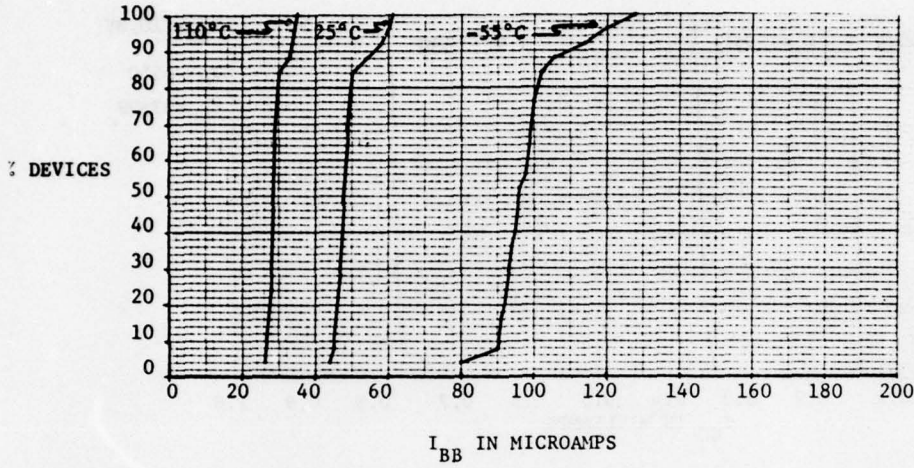

V_{DD} 12.0V
 t_{RC} 375 ns
 t_{RAS} 250 ns

VERSUS TEMPERATURE

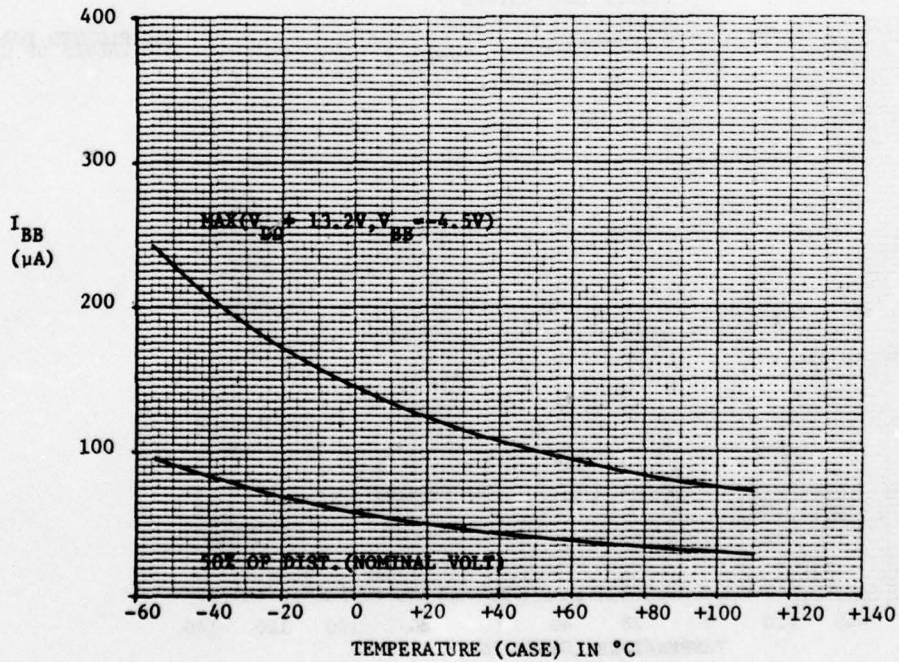

IBM

Vendor: A
P/N: _____
REV: G
Date Code: 7751
DEVICES 25

16K DYNAMIC RAM
OUTPUT DRIVER SUPPLY CURRENT

I_{CC}

By F.A.N. Date 1/20/78
 V_{BB} -5.0V V_{CC} 5.0V
LOAD 1 SCHOTTKY TTL+ CL
ADDR PAT. MULTIPLE
DATA PAT. MULTIPLE

CUMULATIVE DISTRIBUTION

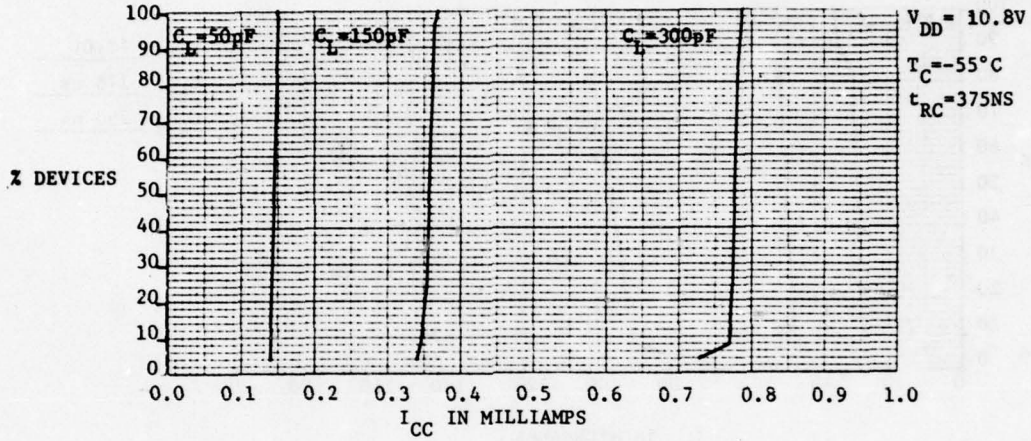

VERSUS TEMPERATURE

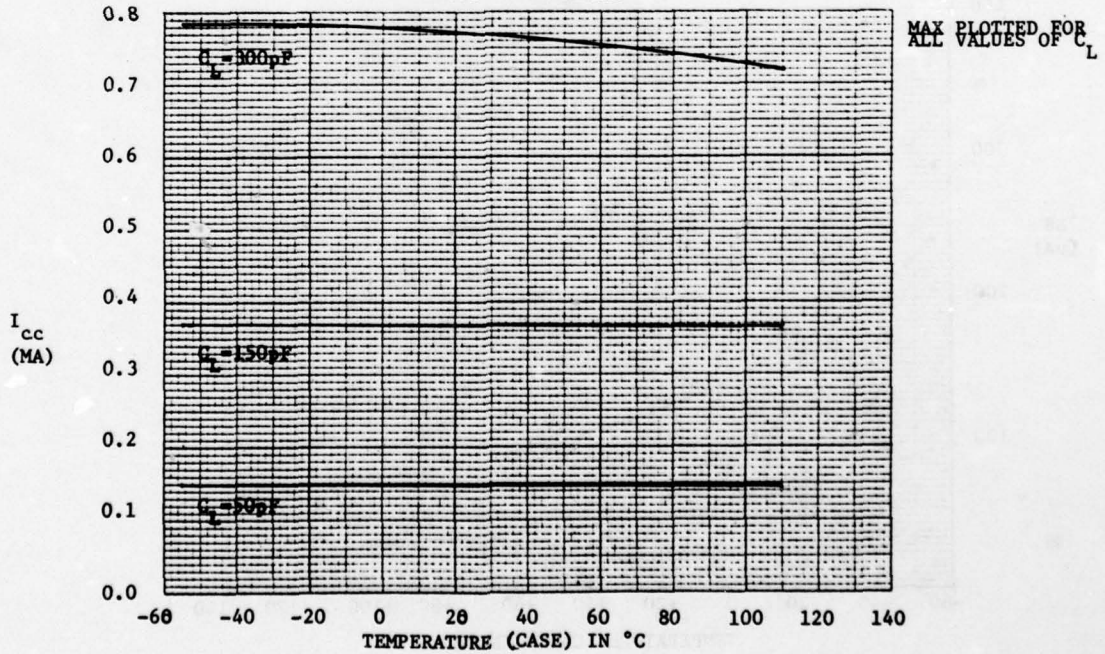

POWER SUPPLY TRANSIENT CURRENT

TEST SETUP

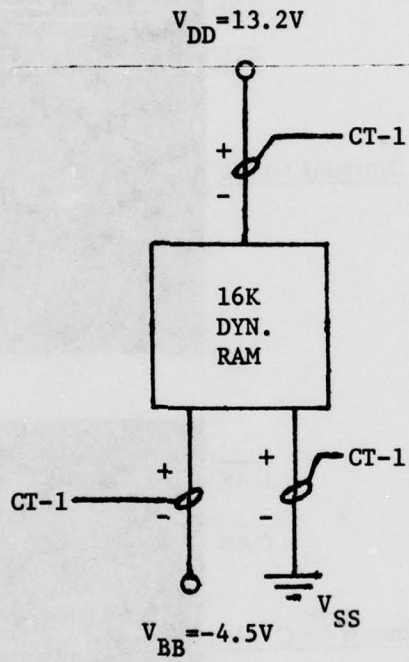

16K Dynamic RAM

Vendor: A
P/N:
Rev: G
Date Code: 7751

Power Supply
Transient Currents
 I_{DD}

By: J.R.F. Date: 2/15/78
 $V_{DD} = 13.2 \text{ V}$
 $V_{BB} = -4.5 \text{ V}$
 $V_{CC} = 5.0 \text{ V}$

Vertical: $\overline{\text{RAS}} \ \ \ \overline{\text{CAS}} = 2 \text{ V/cm}$
 $I_{DD} = 20 \text{ mA/cm}$

Horizontal: 50 ns/cm

$T_{\text{case}} = 25^\circ\text{C}$

Normal Cycle



Long RAS Cycle

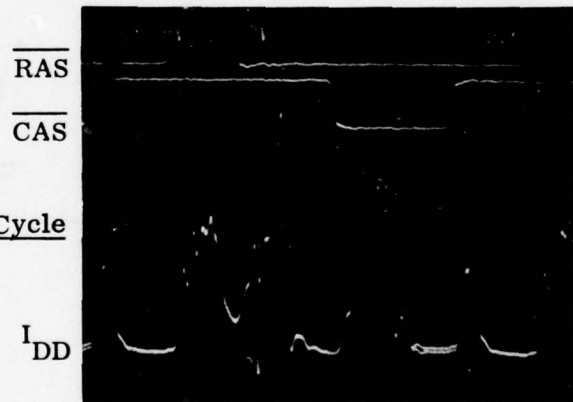

RAS only Cycle

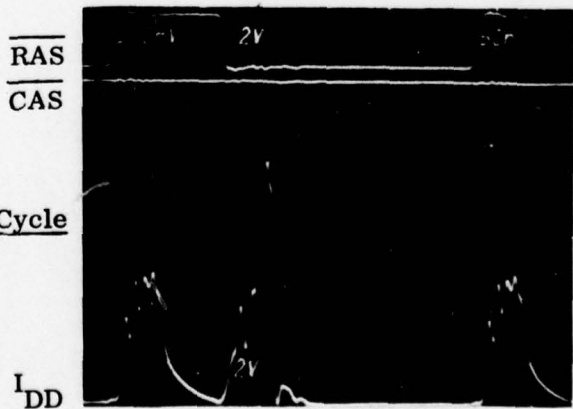

16K Dynamic RAM

Vendor: A
P/N:
Rev: G
Date Code: 7751

Power Supply
Transient Currents
 I_{DD}

By: J.R.F. Date: 2/15/78

$V_{DD} = 13.2 \text{ V}$
 $V_{BB} = -4.5 \text{ V}$
 $V_{CC} = 5.0 \text{ V}$

Vertical: $\overline{\text{RAS}} \ \overline{\text{CAS}} = 2 \text{ V/cm}$
 $I_{DD} = 20 \text{ mA/cm}$

Horizontal: = 50 ns/cm

$T_{\text{case}} = 110^\circ\text{C}$

Normal Cycle

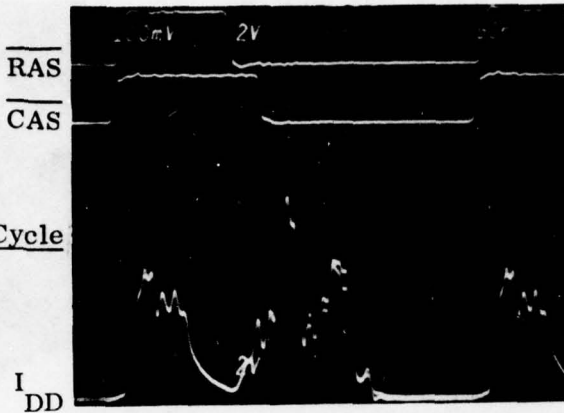

Long RAS Cycle

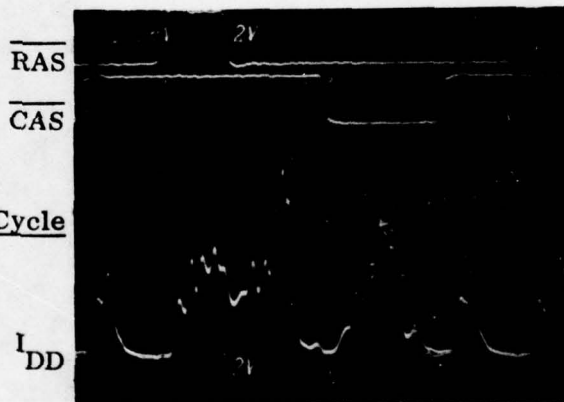

RAS only Cycle

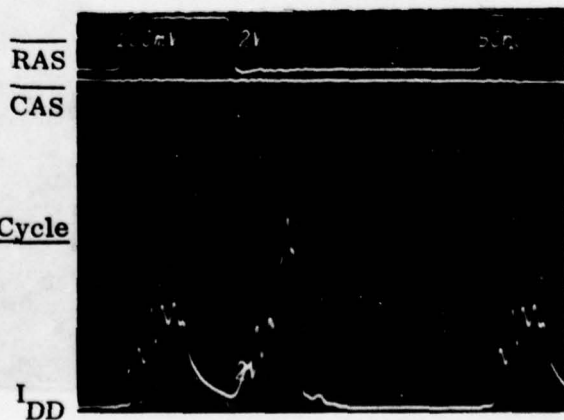

16K Dynamic RAM

Vendor: A
P/N:
Rev: G
Date Code: 7751

Power Supply
Transient Currents

By: J.R.F. Date: 2/15/78

$V_{DD} = 13.2 \text{ V}$
 $V_{BB} = -4.5 \text{ V}$
 $V_{CC} = 5.0 \text{ V}$

I_{DD}

Vertical: $\overline{\text{RAS}} \ \ \ \overline{\text{CAS}} = 2 \text{ V/cm}$
 $I_{DD} = 20 \text{ mA/cm}$

Horizontal: 50 ns/cm

$T_{\text{case}} = -55^\circ\text{C}$

$\overline{\text{RAS}}$

$\overline{\text{CAS}}$



Normal Cycle

I_{DD}

$\overline{\text{RAS}}$

$\overline{\text{CAS}}$

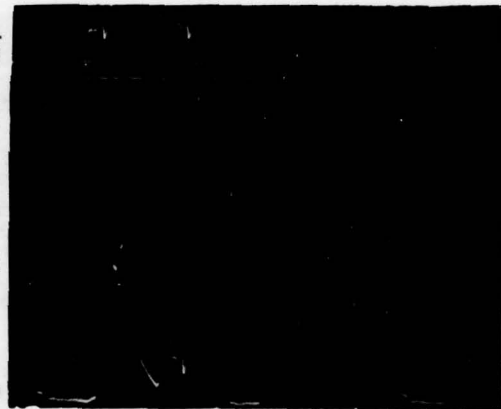

Long RAS Cycle

I_{DD}

$\overline{\text{RAS}}$

$\overline{\text{CAS}}$

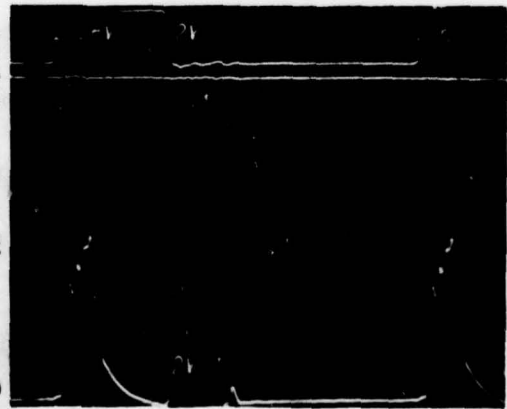

RAS only Cycle

I_{DD}

16K Dynamic RAM

Vendor: A
P/N:
Rev: G
Date Code: 7751

Power Supply
Transient Currents
 I_{BB}

By: J.R.F. Date: 2/15/78
 $V_{DD} = 13.2 \text{ V}$
 $V_{BB} = -4.5 \text{ V}$
 $V_{CC} = 5.0 \text{ V}$

Vertical: $\overline{\text{RAS}} \ \ \ \overline{\text{CAS}} = 2 \text{ V/cm}$
 $I_{BB} = 20 \text{ mA/cm}$

Horizontal: 50 ns/cm

$T_{\text{case}} = 25^\circ\text{C}$

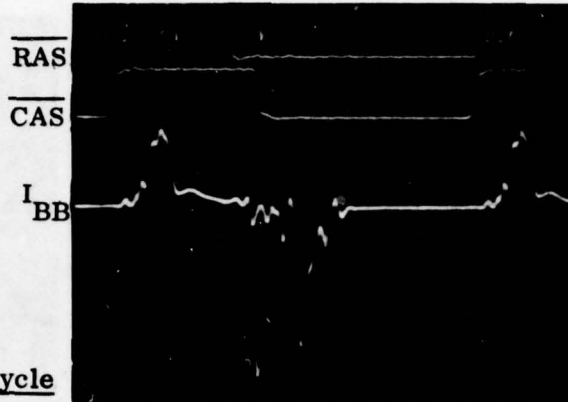

Normal Cycle

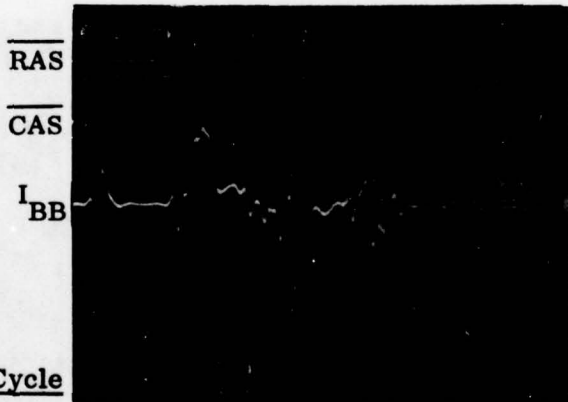

Long RAS Cycle

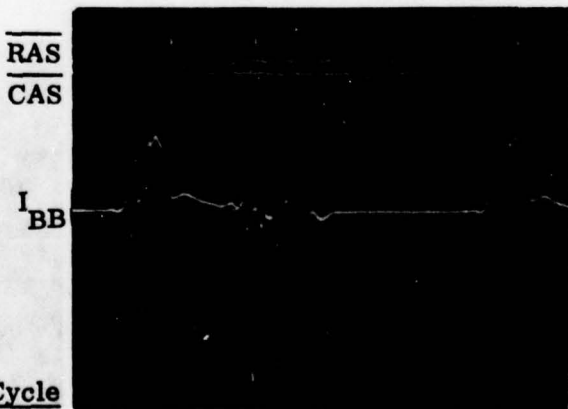

RAS only Cycle

16K Dynamic RAM

Vendor: A
P/N:
Rev: G
Date Code: 7751

Power Supply
Transient Currents
 I_{BB}

By: J.R.F. Date: 2/15/78
 $V_{DD} = 13.2\text{ V}$
 $V_{BB} = -4.5\text{ V}$
 $V_{CC} = 5.0\text{ V}$

Vertical: $\overline{\text{RAS}} \ \ \ \ \overline{\text{CAS}} = 2\text{ V/cm}$
 $I_{BB} = 20\text{ mA/cm}$

Horizontal: 50 ns/cm

$T_{\text{case}} = 110^\circ\text{C}$

$\overline{\text{RAS}}$

$\overline{\text{CAS}}$

I_{BB}

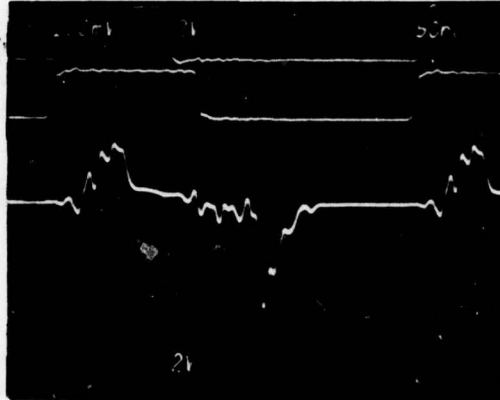

Normal Cycle

$\overline{\text{RAS}}$

$\overline{\text{CAS}}$

I_{BB}

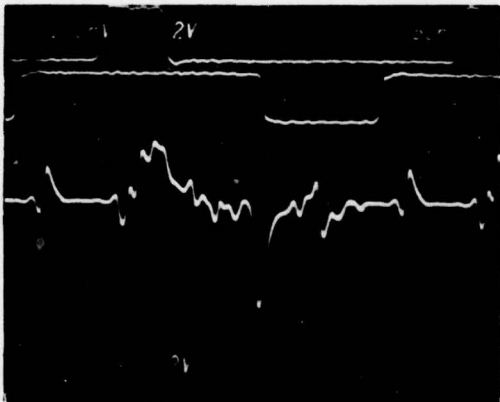

Long $\overline{\text{RAS}}$ Cycle

$\overline{\text{RAS}}$

$\overline{\text{CAS}}$

I_{BB}

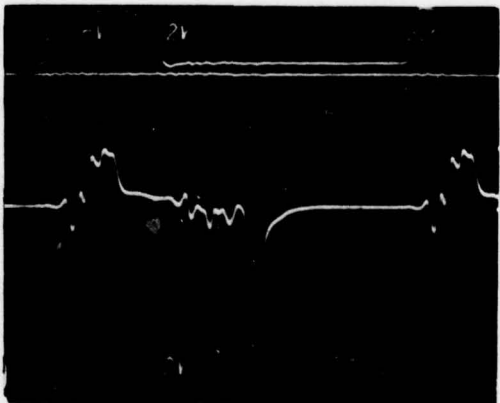

$\overline{\text{RAS}}$ only Cycle

16K Dynamic RAM

Vendor: A
P/N:
Rev: G
Date Code: 7751

Power Supply
Transient Currents
 I_{BB}

By: J.R.F. Date: 2/15/78
 $V_{DD} = 13.2\text{ V}$
 $V_{BB} = -4.5\text{ V}$
 $V_{CC} = 5.0\text{ V}$

Vertical: $\overline{\text{RAS}} \ \ \ \overline{\text{CAS}} = 2\text{ V/cm}$
 $I_{SS} = 20\text{ mA/cm}$

Horizontal: 50 ns/cm

$T_{\text{case}} = -55^\circ\text{C}$

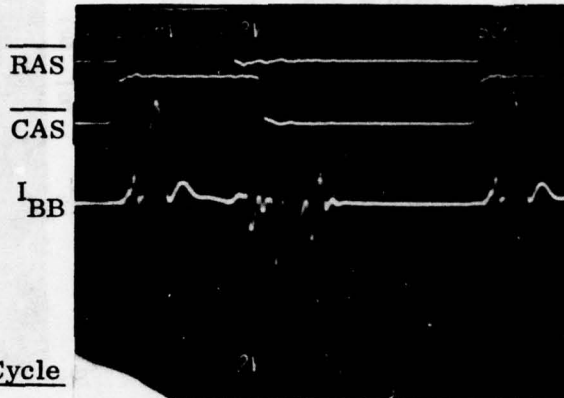

Normal Cycle

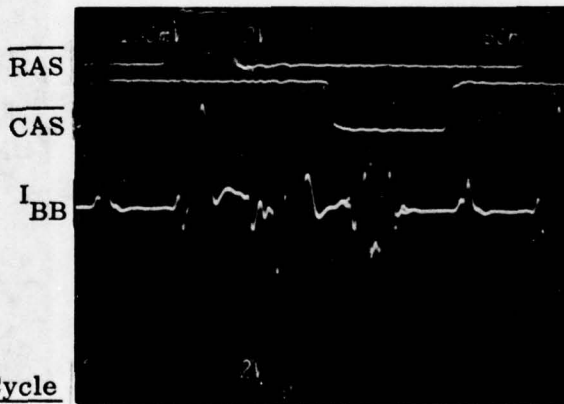

Long RAS Cycle

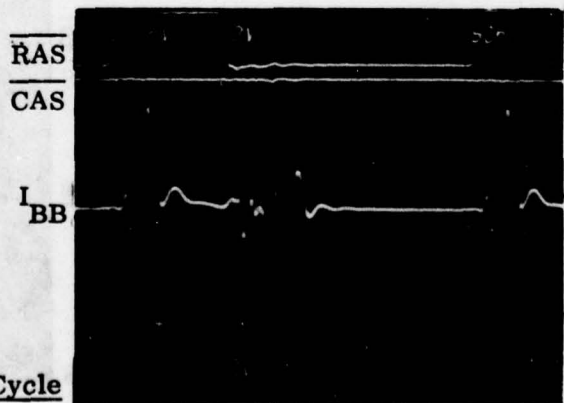

RAS only Cycle

16K Dynamic RAM

Vendor: A
P/N:
Rev: G
Date Code: 7751

Power Supply
Transient Currents
 I_{SS}

By: J.R.F. Date: 2/15/78
 $V_{DD} = 13.2\text{ V}$
 $V_{BB} = -4.5\text{ V}$
 $V_{CC} = 5.0\text{ V}$

Vertical: RAS & CAS = 2 V/cm
 $I_{SS} = 20\text{ mA/cm}$

Horizontal: 50 ns/cm

$T_{case} = 25^\circ\text{C}$

RAS

CAS

Normal Cycle

I_{SS}

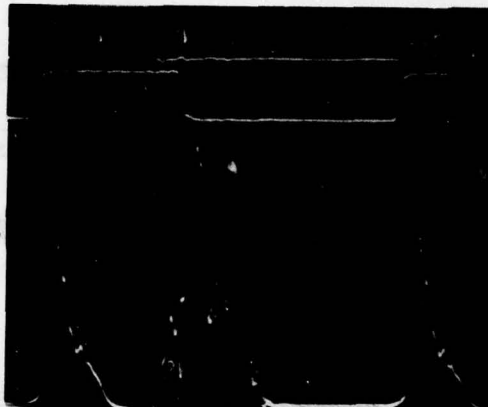

RAS

CAS

Long RAS Cycle

I_{SS}

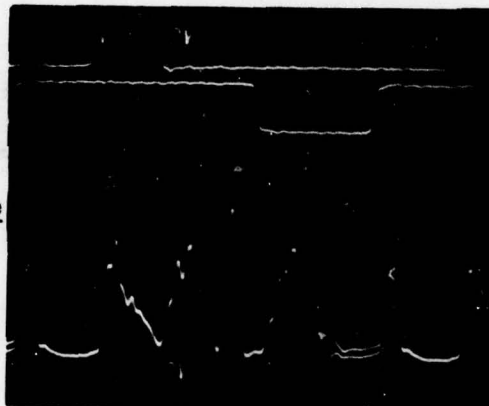

RAS

CAS

RAS only Cycle

I_{SS}

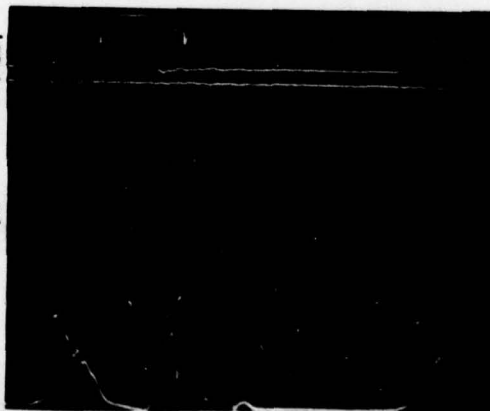

16K Dynamic RAM

Vendor: A
P/N:
Rev: G
Date Code: 7751

Power Supply
Transient Currents
 I_{SS}

By: J.R.F. Date: 2/15/78
 $V_{DD} = 13.2\text{ V}$
 $V_{BB} = -4.5\text{ V}$
 $V_{CC} = 5.0\text{ V}$

Vertical: $\overline{\text{RAS}} \ \ \ \ \overline{\text{CAS}} = 2\text{ V/cm}$
 $I_{SS} = 20\text{ mA/cm}$

Horizontal: 50 ns/cm

$T_{\text{case}} = 110^\circ\text{C}$

Normal Cycle

$\overline{\text{RAS}}$

$\overline{\text{CAS}}$

I_{SS}

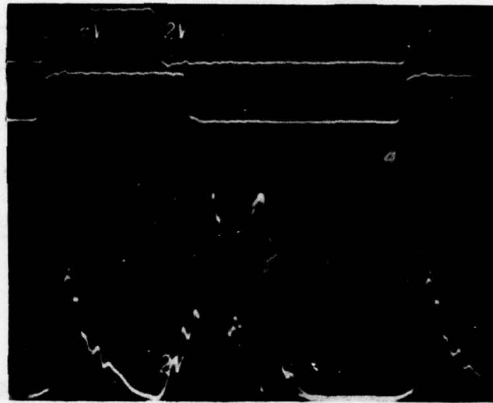

Long RAS Cycle

$\overline{\text{RAS}}$

$\overline{\text{CAS}}$

I_{SS}

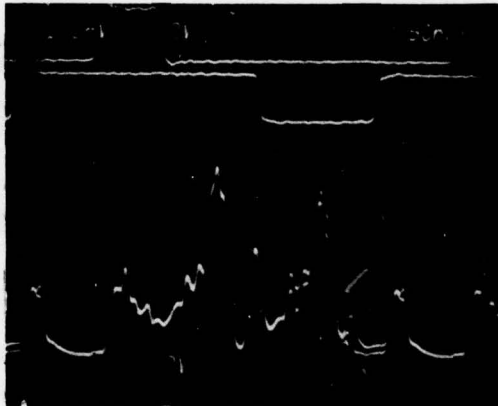

RAS only Cycle

$\overline{\text{RAS}}$

$\overline{\text{CAS}}$

I_{SS}

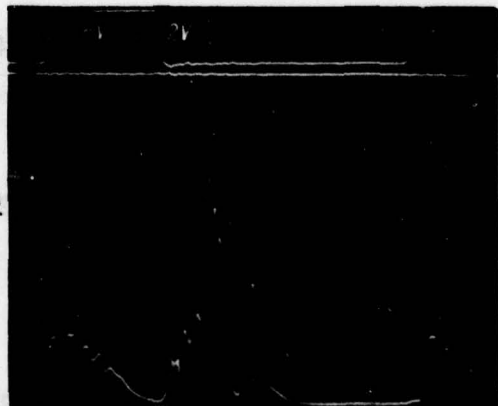

16K Dynamic RAM

Vendor: A
P/N:
Rev: G
Date Code: 7751

Power Supply
Transient Currents

By: J.R.F. Date: 2/15/78

$V_{DD} = 13.2 \text{ V}$

$V_{BB} = -4.5 \text{ V}$

$V_{CC} = 5.0 \text{ V}$

Vertical: $\overline{\text{RAS}} \text{ \& \ } \overline{\text{CAS}} = 2 \text{ V/cm}$
 $I_{BB} = 20 \text{ mA/cm}$

Horizontal: 50 ns/cm

$T_{\text{case}} = -55^\circ\text{C}$

$\overline{\text{RAS}}$
 $\overline{\text{CAS}}$

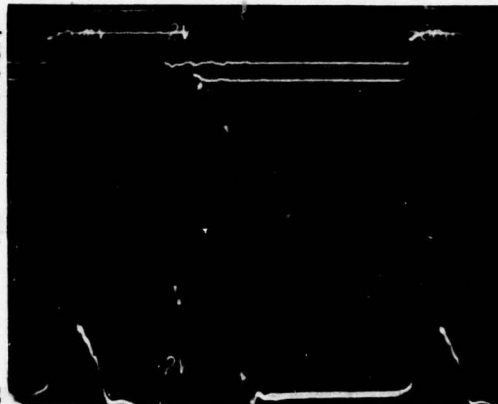

Normal Cycle

I_{SS}

$\overline{\text{RAS}}$
 $\overline{\text{CAS}}$

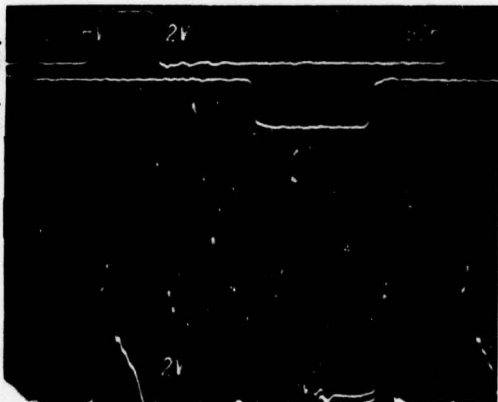

Long RAS Cycle

I_{SS}

$\overline{\text{RAS}}$
 $\overline{\text{CAS}}$

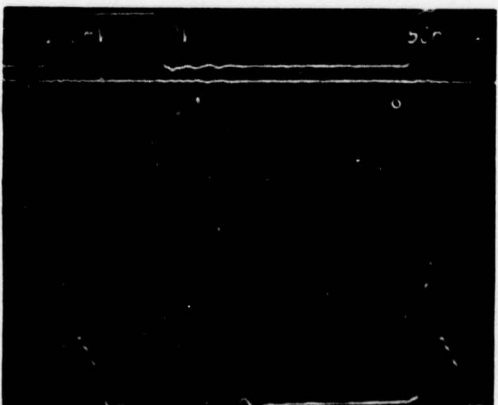

RAS only Cycle

I_{SS}

SHMOC V_{DD} -VS- V_{BB}

DATE 1/16/78

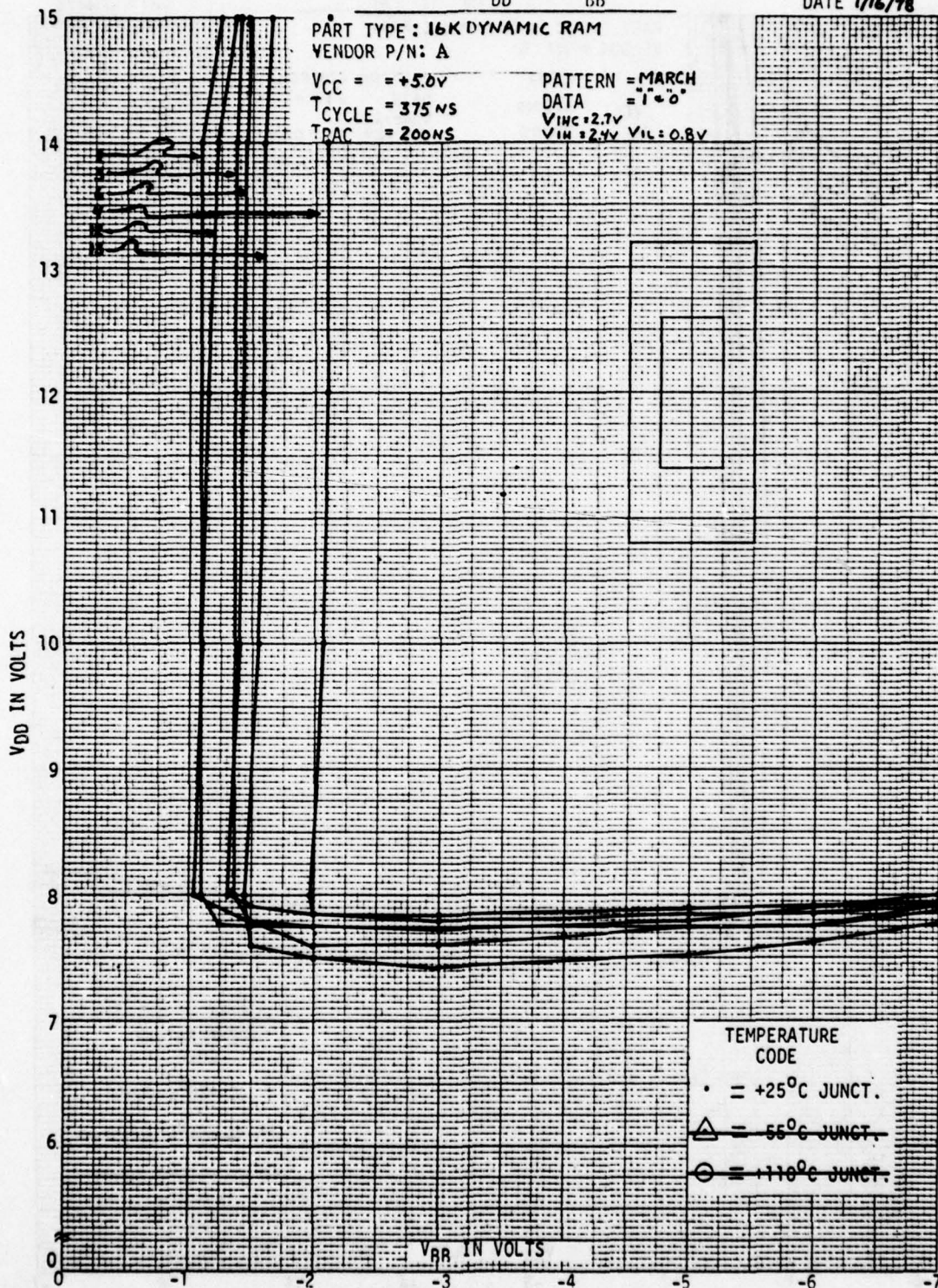

SHMOO V_{DD} -VS- V_{BB}

DATE 1/16/78

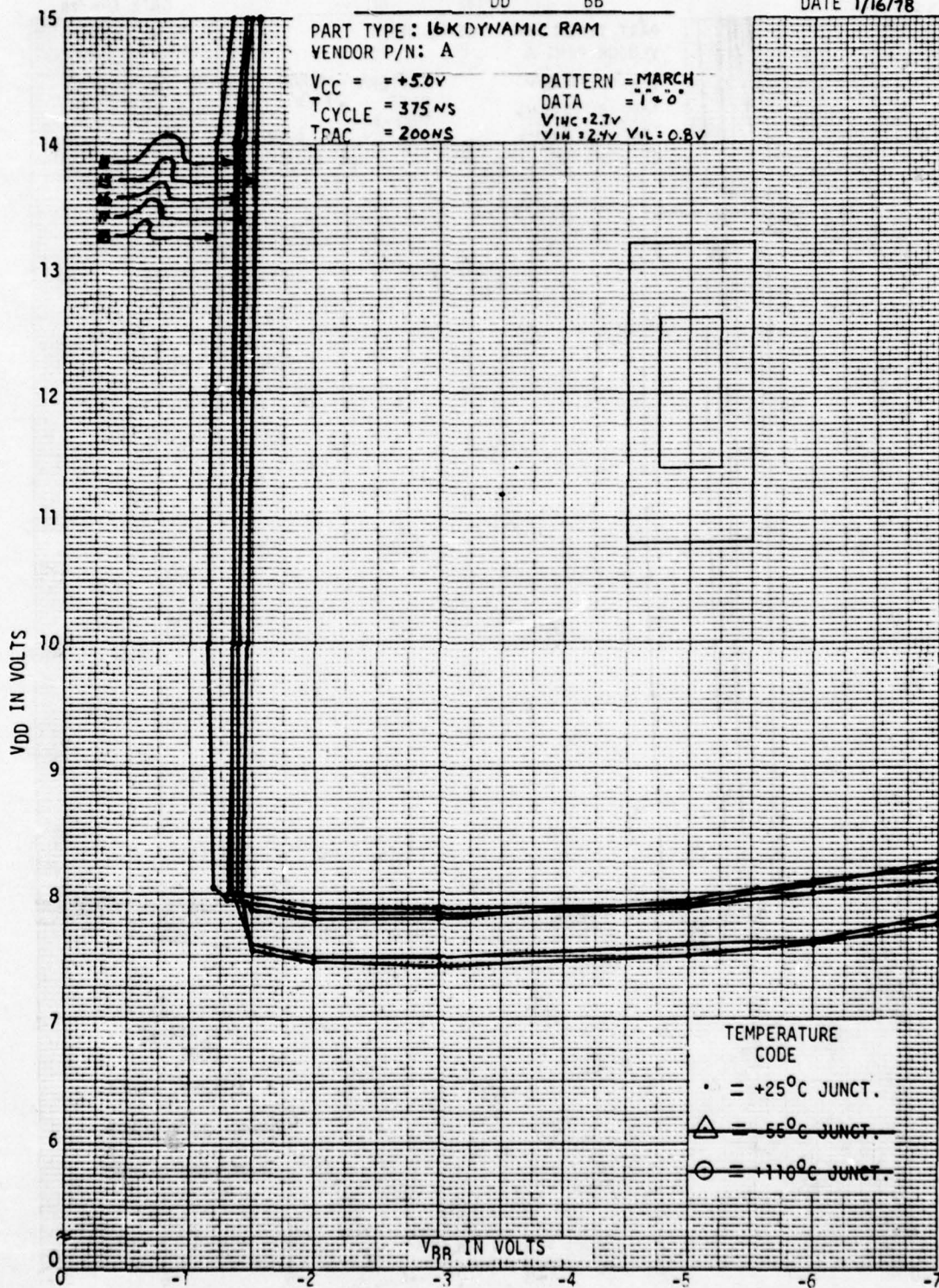

SH'00 V_{DD} -VS- V_{BB}

DATE 1/13/78

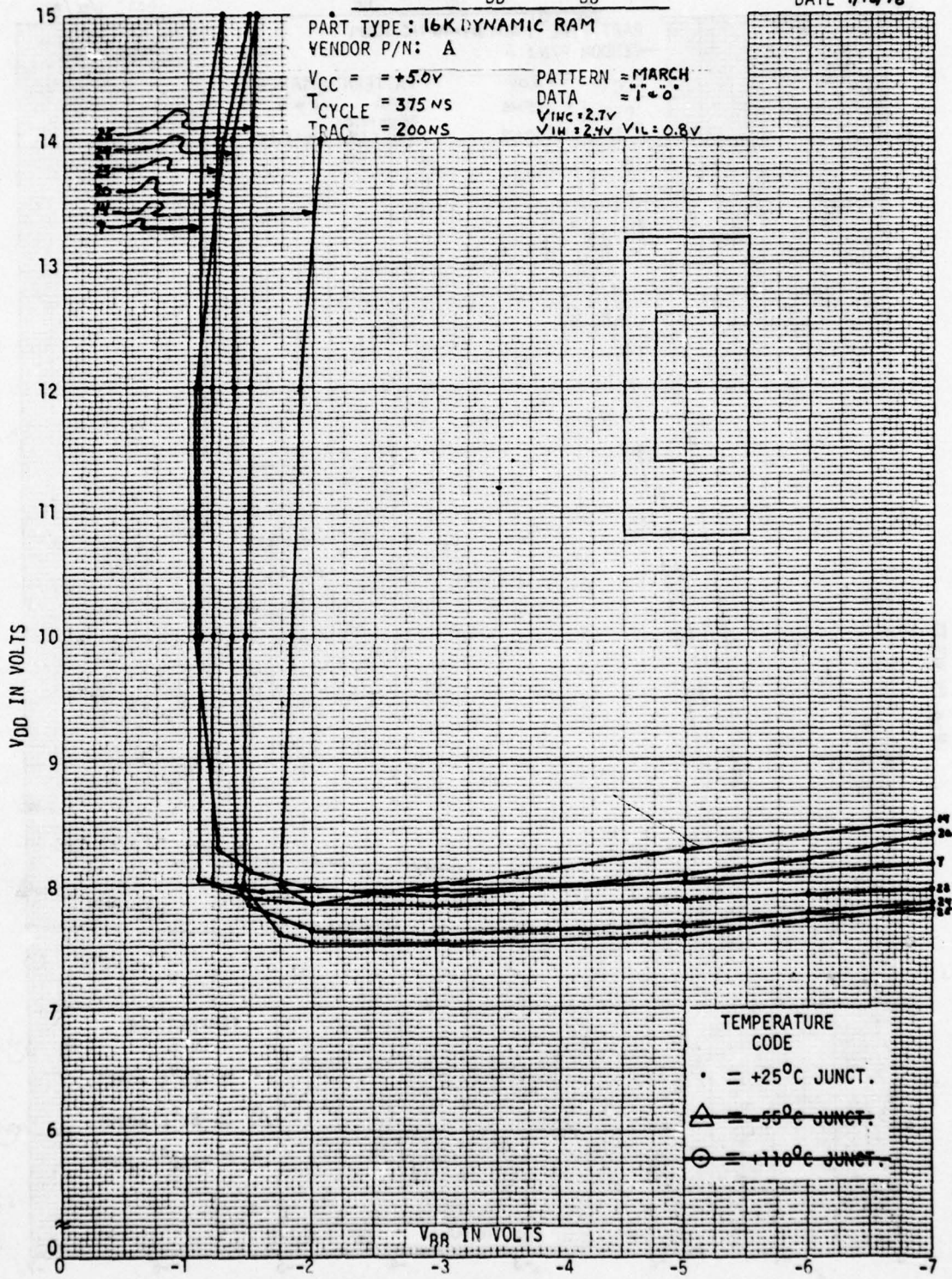

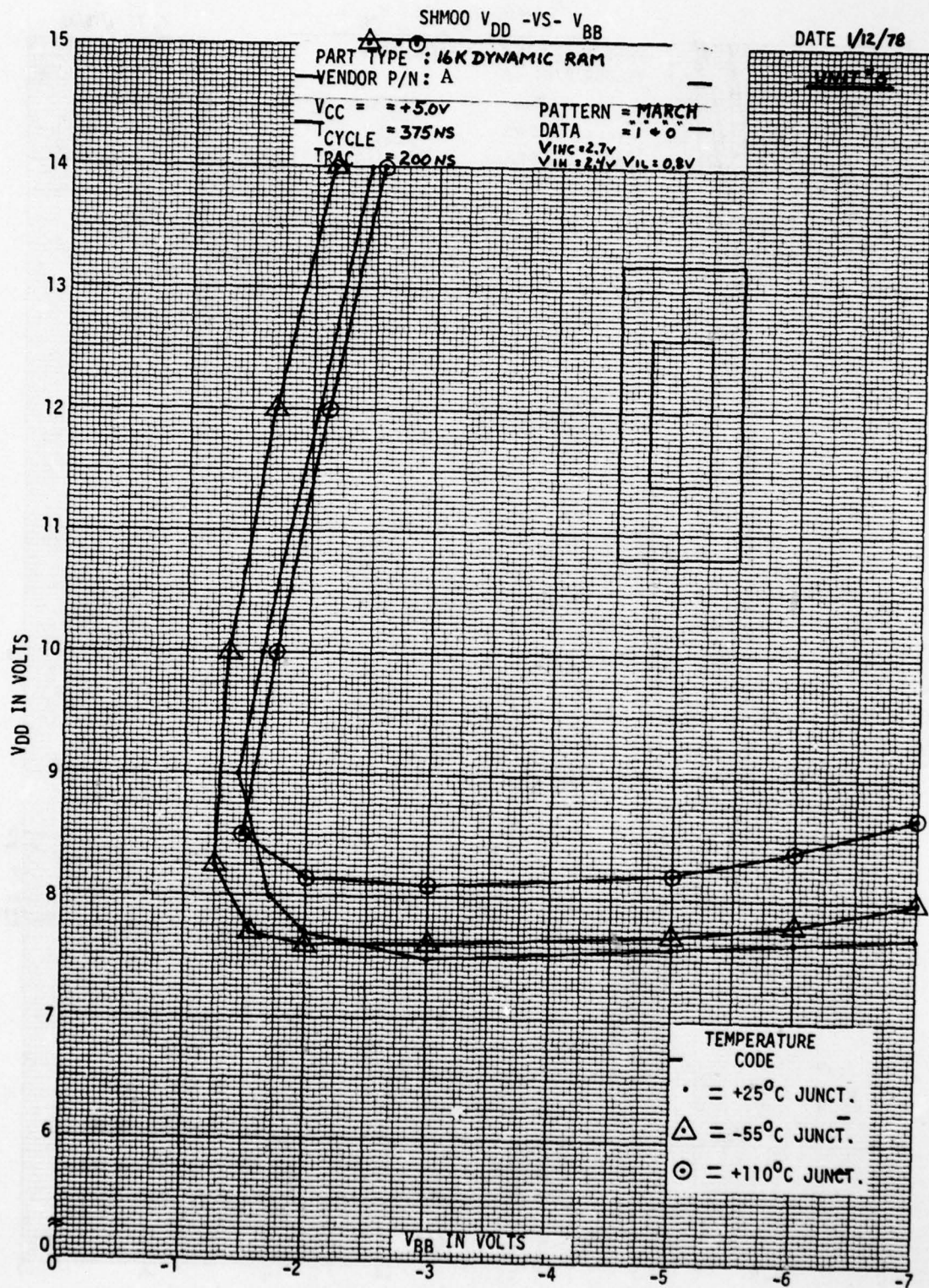

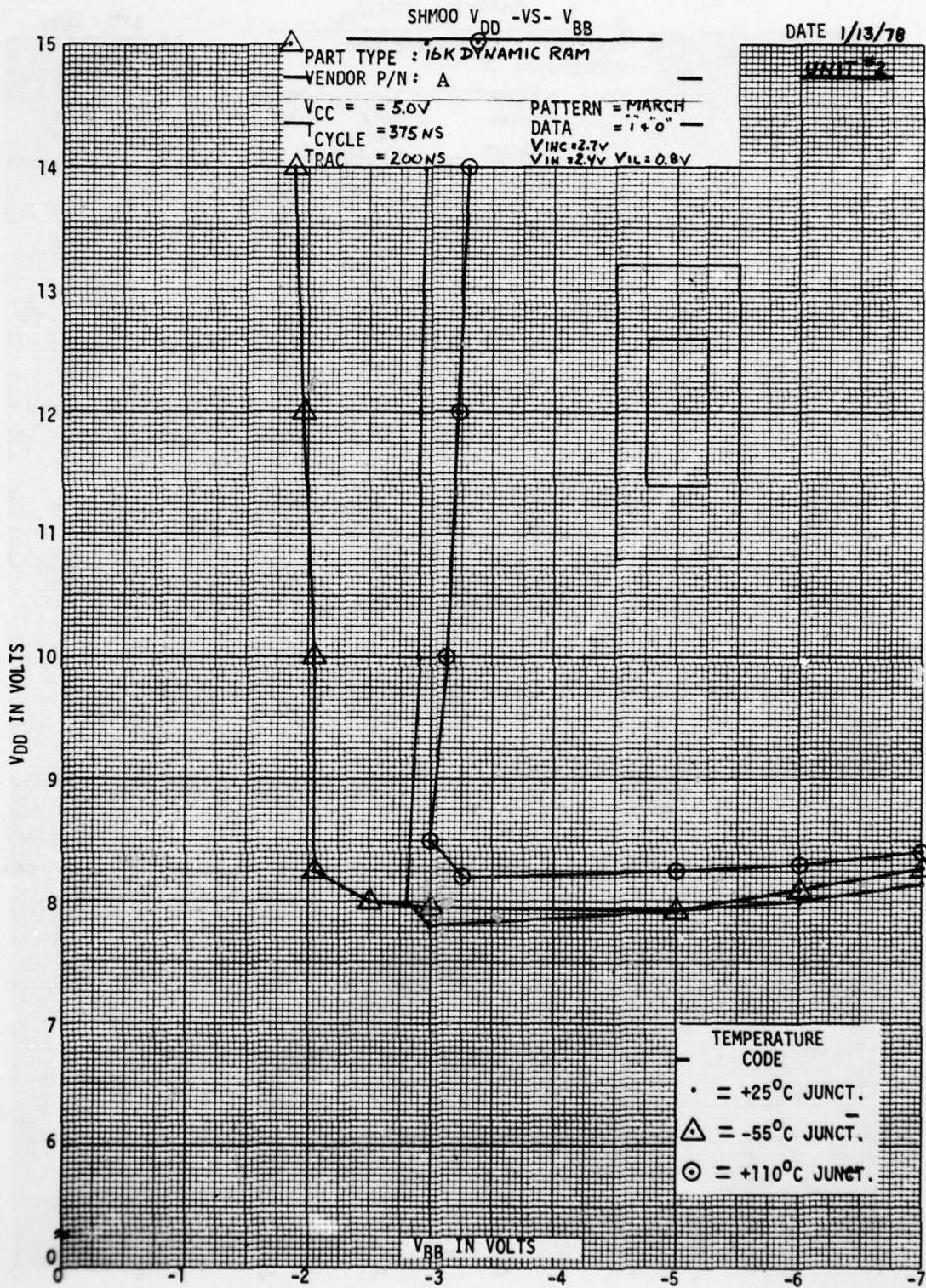

SHMOO V_{DD} -VS- V_{BB}

DATE 1/13/78

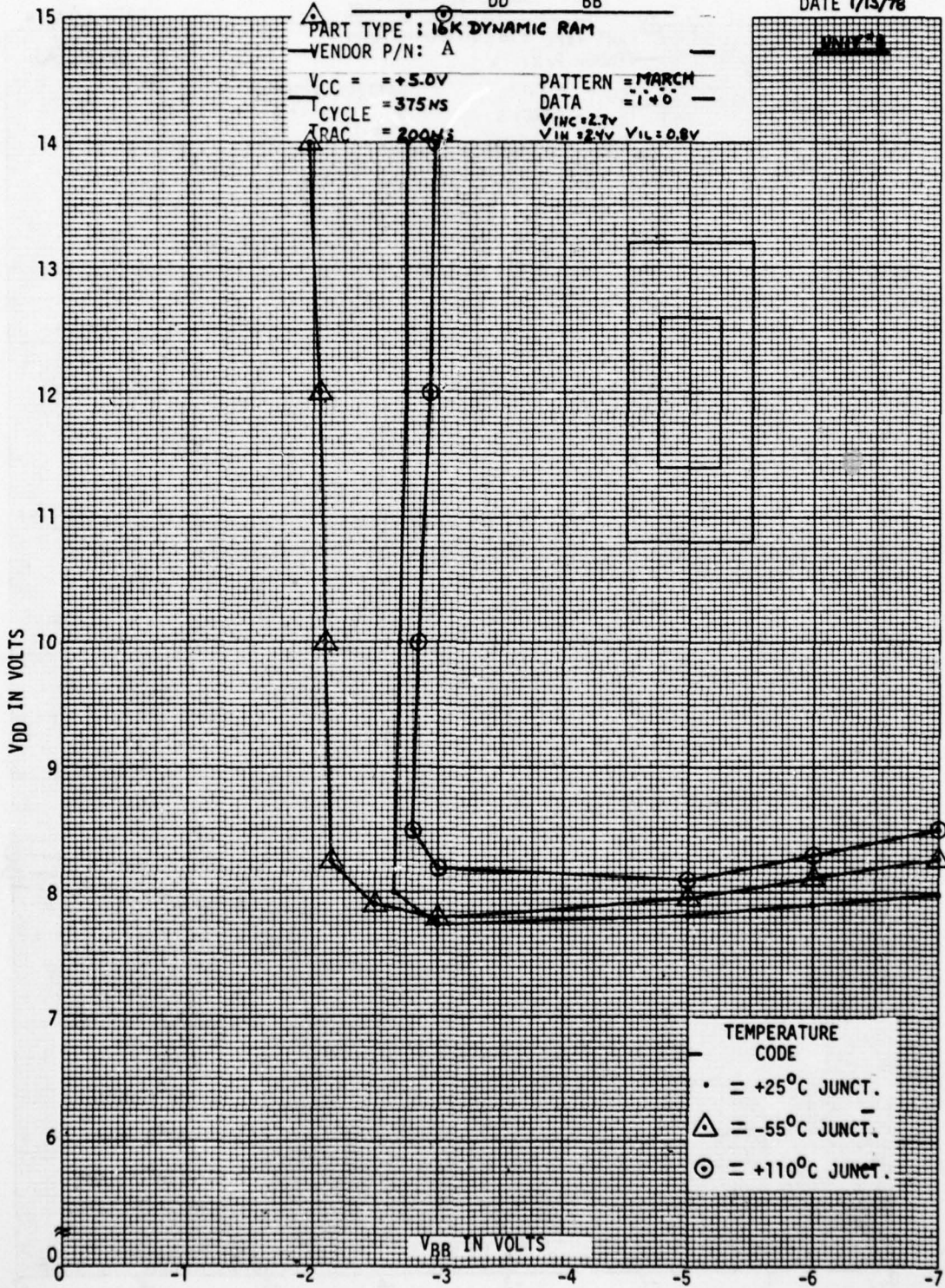

SHMOO V_{DD} -VS- V_{BB}

DATE 1/13/78

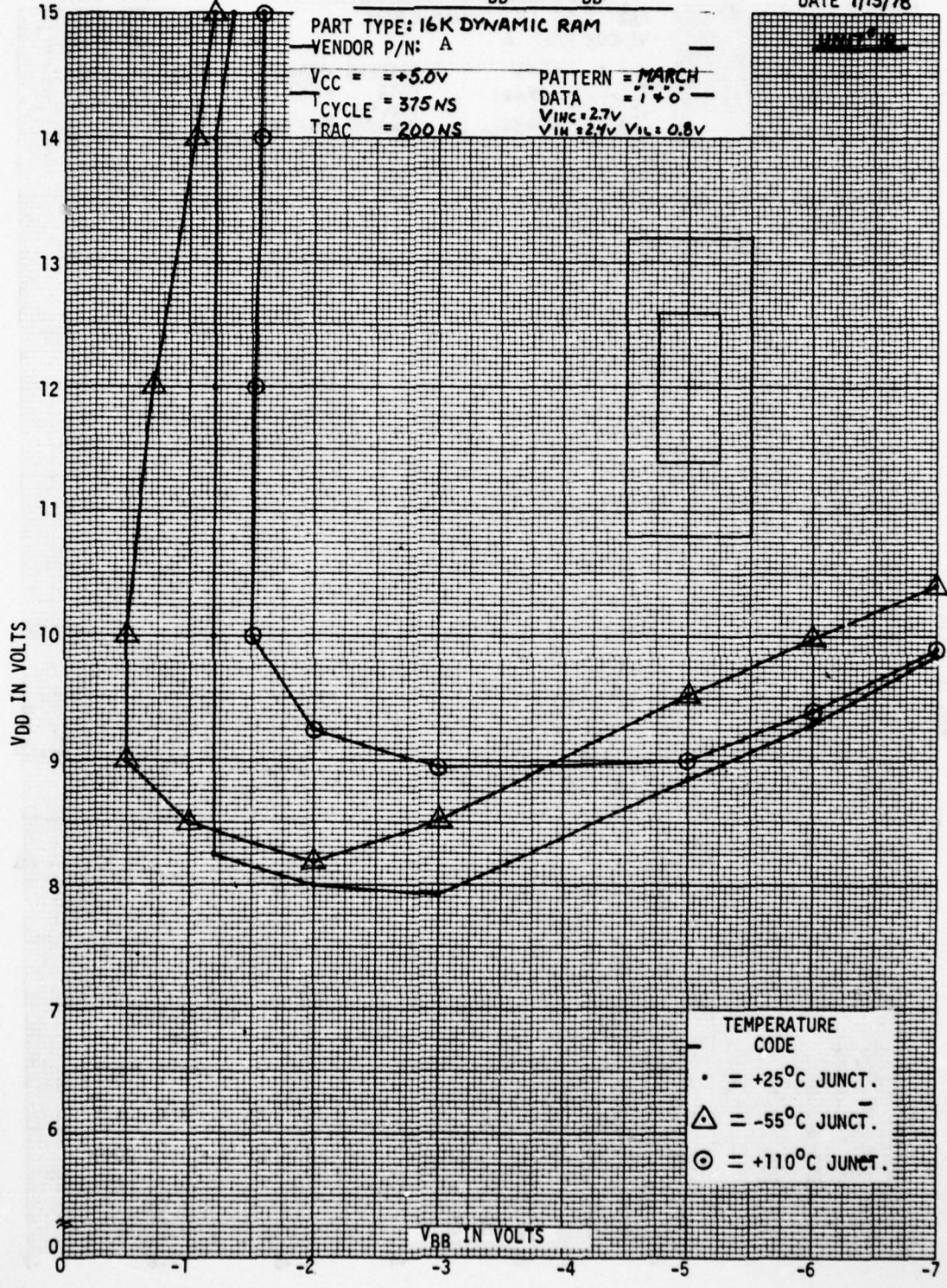

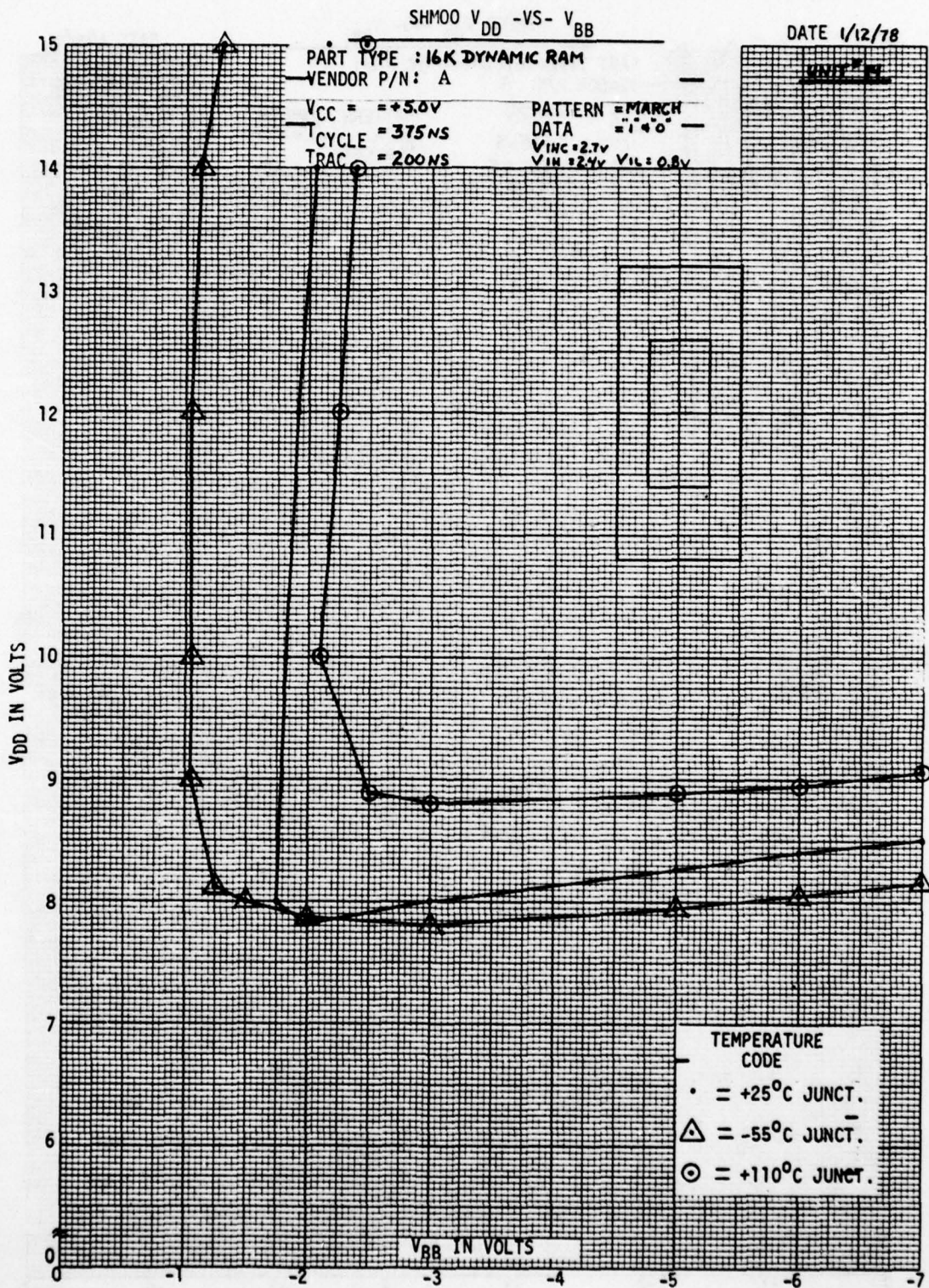

SHMOO V_{DD} -VS- V_{BB}

DATE 1/13/78

PART TYPE : 16K DYNAMIC RAM
VENDOR P/N: A

V_{CC} = +5.0V
CYCLE = 375NS
TRAC = 200NS

PATTERN = MARCH
DATA = 1'0'
 V_{INC} = 2.7V
 V_{IH} = 2.4V V_{IL} = 0.8V

UNIT: V

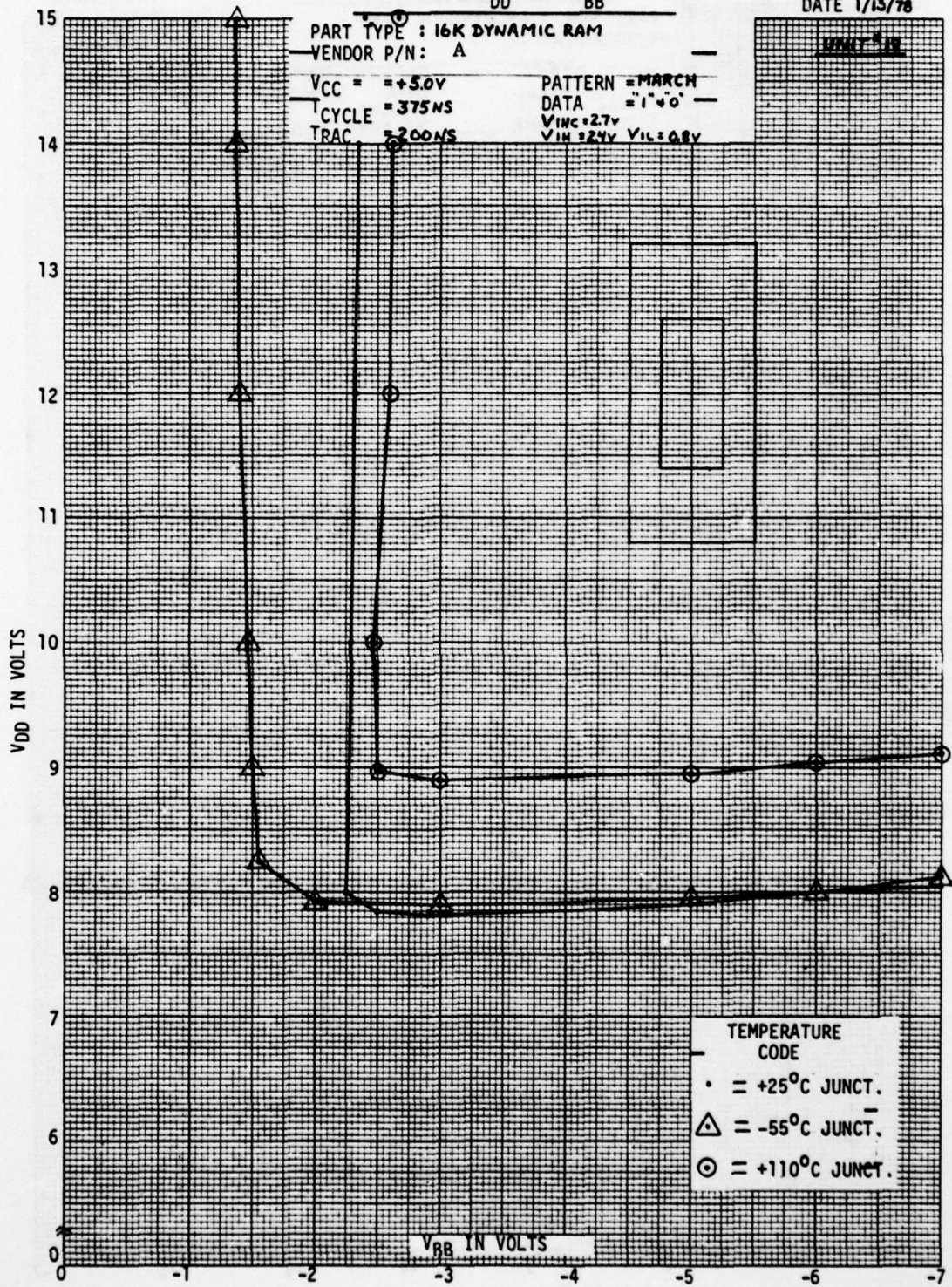

SHMOO V_{DD} -VS- V_{BB}

DATE 1/13/78

PART TYPE : 16K DYNAMIC RAM

VENDOR P/N: A

V_{CC} = +5.0V

PATTERN = MARCH

T CYCLE = 375NS

DATA = 1*0

T RAC = 200NS

V_{INC} = 2.7V

V_{IH} = 2.4V V_{IL} = 0.8V

UNIT # 24

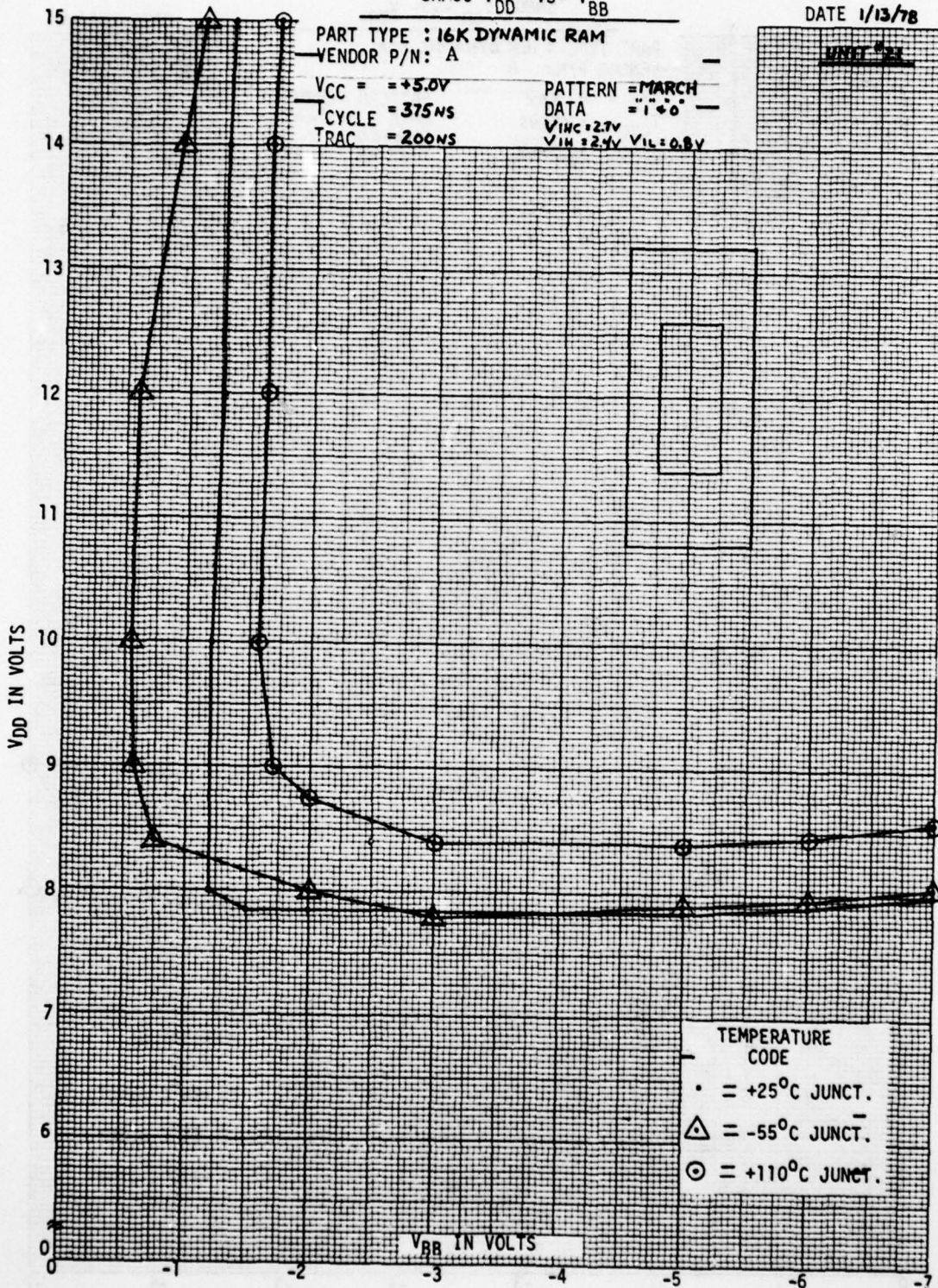

SHMOO V_{DD} -VS- V_{BB}

DATE 1/13/78

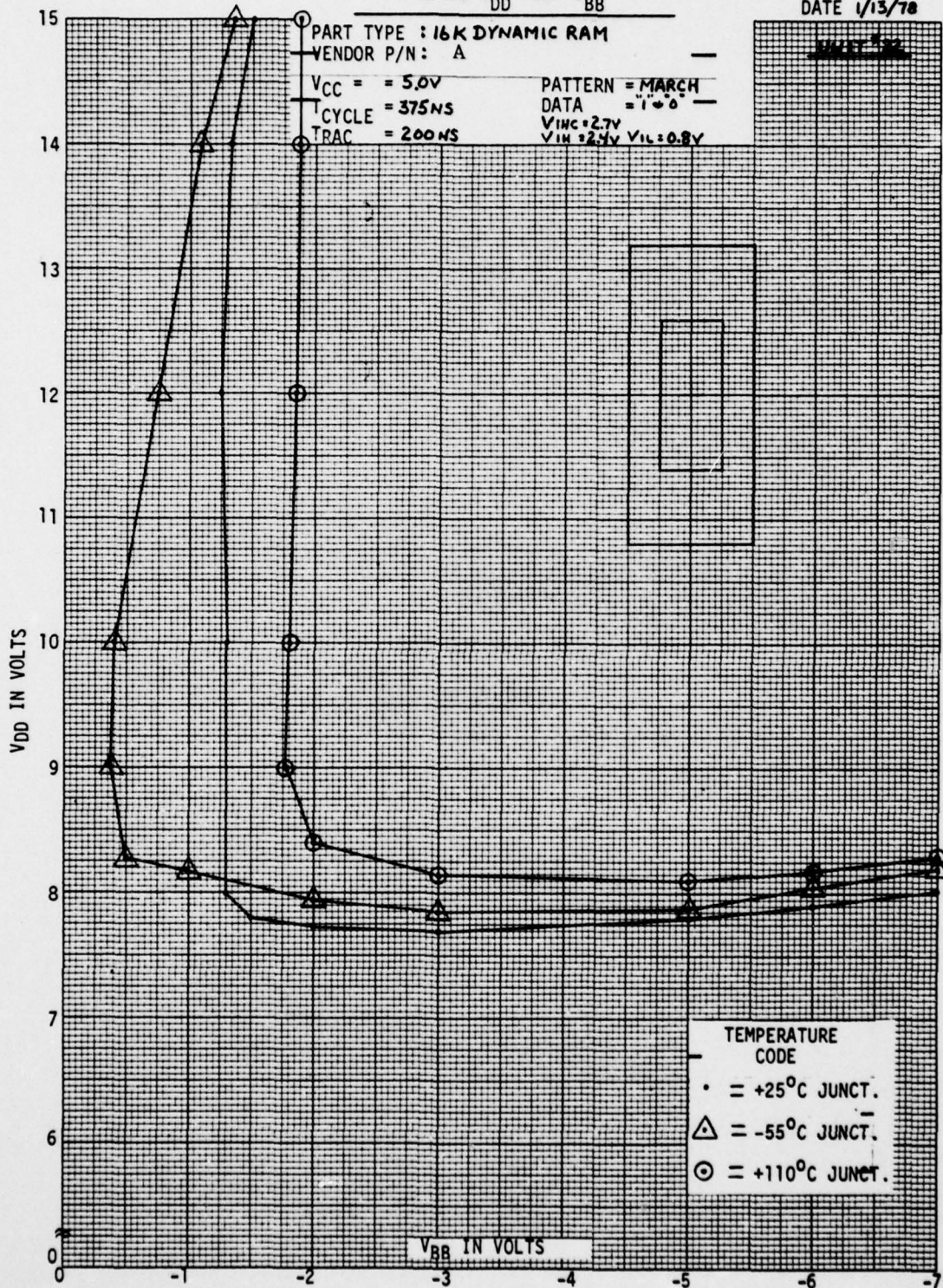

APPENDIX II
16K DYNAMIC RAM
VENDOR B

Vendor: B
 P/N: _____
 REV: (Shrink)
 Date Code: 7820
 # Device: 27

16K DYNAMIC RAM
 ACCESS TIME FROM CAS
 t_{CAC}

By J.R.F. Date 6/13/78
 V_{BB} -4.5V V_{CC} 5.0V
 LOAD 1 Schottky TTL + 50pF
 ADDR PAT. Multiple
 DATA PAT. Multiple

V_{IH} 2.7V
 V_{IH} 2.4V
 V_{IL} 0.8V

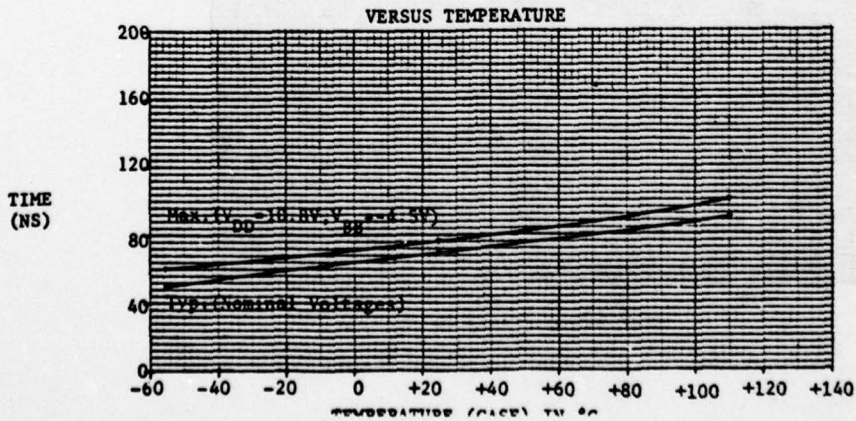
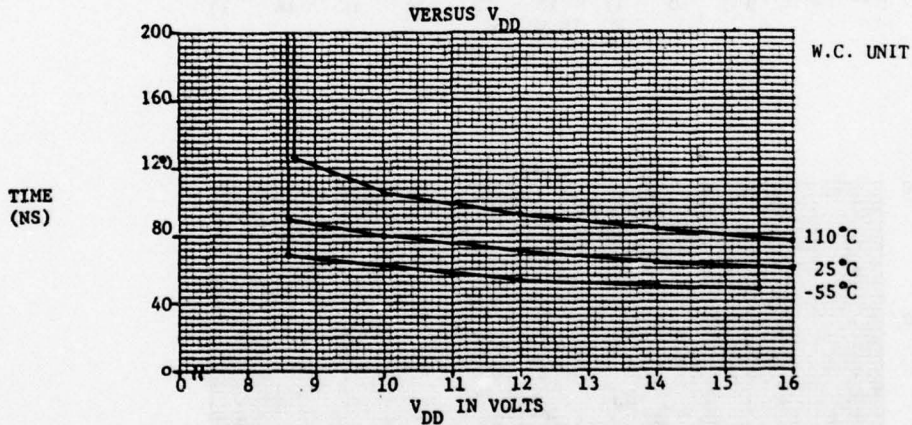
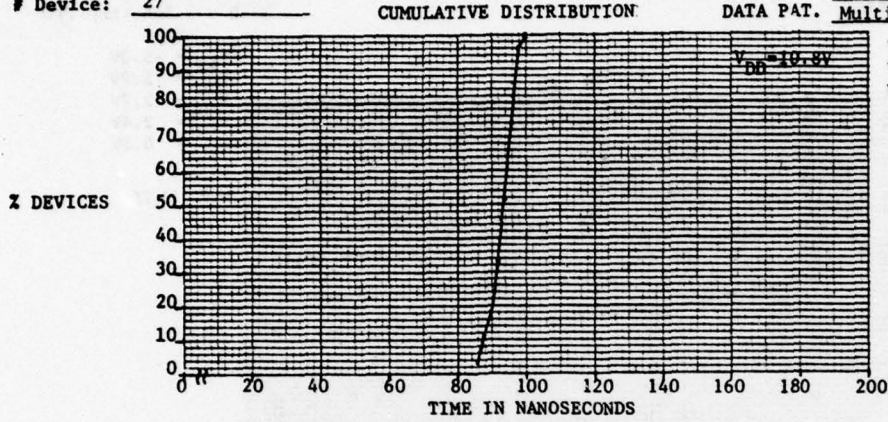

Vendor: B
 P/N: _____
 Rev: (Shrink)
 Date Code: 7820

16K DYNAMIC RAM
 ACCESS TIME FROM RAS

By J.R.F. 6/12/78
 ADDR.PAT = Multiple
 DATA PAT = Multiple
 LOAD = 1 Schottky TTL
 +50pF

t_{RAC}

$V_{BB} = -5.0V$
 $V_{CC} = 5.0V$
 $V_{IHC} = 2.7V$
 $V_{IHL} = 2.4V$
 $V_{IL} = 0.8V$

W.C. UNIT

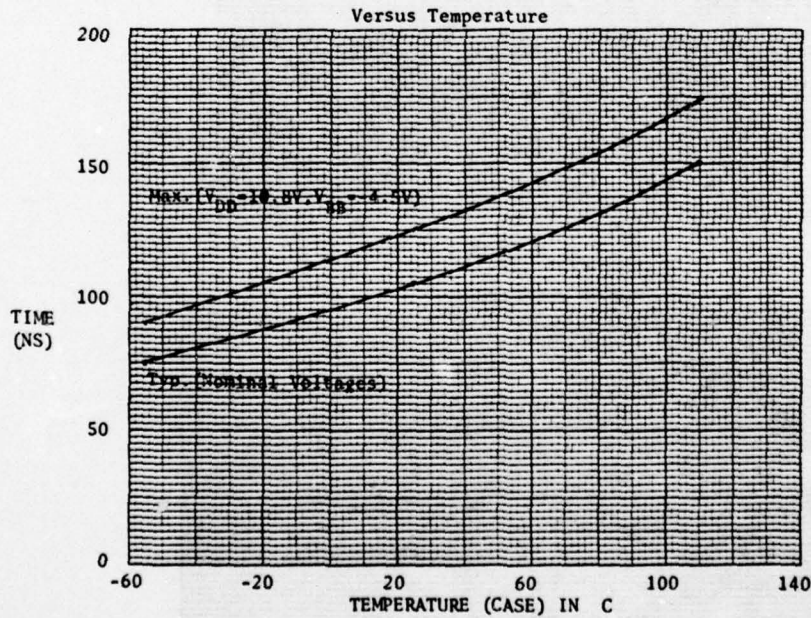
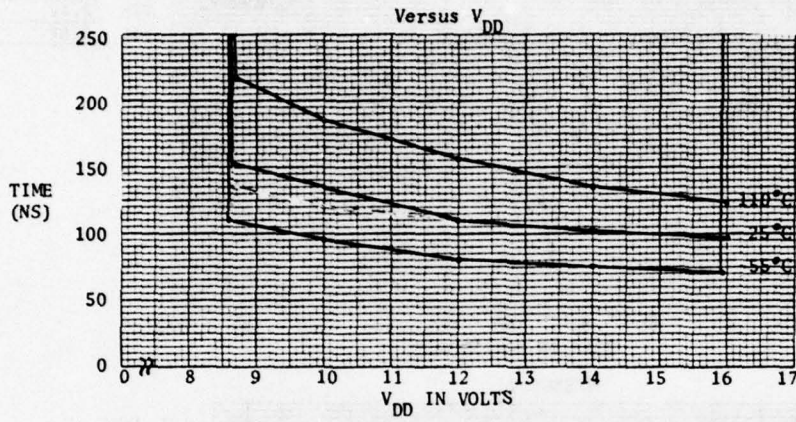

Vendor: B
 P/N: _____
 REV: (Shrink)
 Date Code: 7820
 # Device: 27

16K DYNAMIC RAM
RAS PRECHARGE TIME
 t_{RP}

By J.R.F. Date 6/12/78
 V_{BB} -4.5V V_{CC} 5.0V
 LOAD PAT. NA
 ADDR PAT. Multiple
 DATA PAT. Multiple

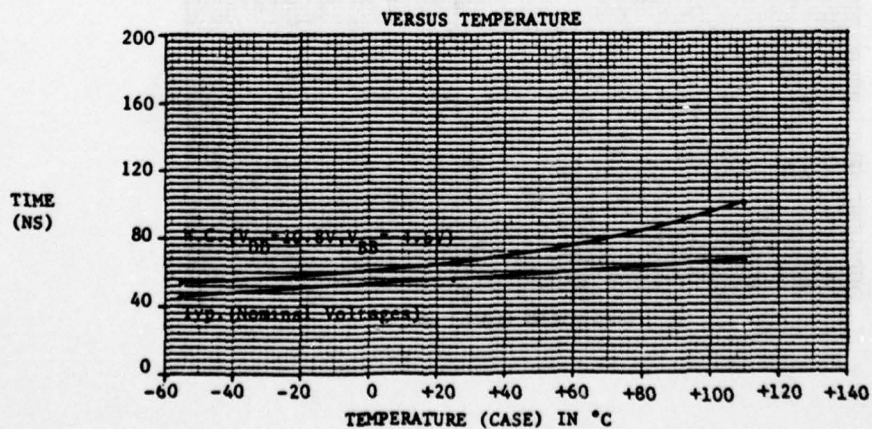
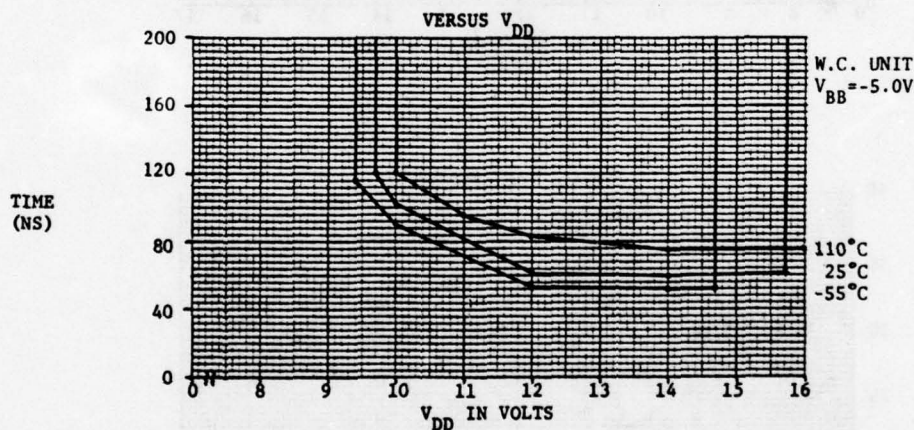
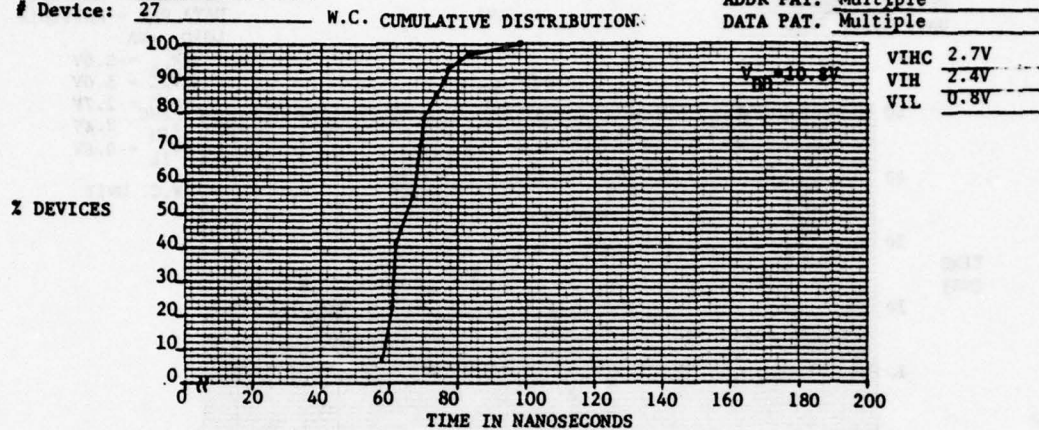

Vendor: B
 P/N: _____
 Rev.: (Shrink)
 Date Code: 7820

16K DYNAMIC RAM
 ROW ADDRESS HOLD TIME

t_{RAH}

By J.R.F. 6/7/78
 ADDR.PAT = Multiple
 DATA PAT = Multiple
 LOAD = NA

$V_{BB} = -5.0V$
 $V_{CC} = 5.0V$
 $V_{IHC} = 2.7V$
 $V_{IH} = 2.4V$
 $V_{IL} = 0.8V$
 W.C.: UNIT

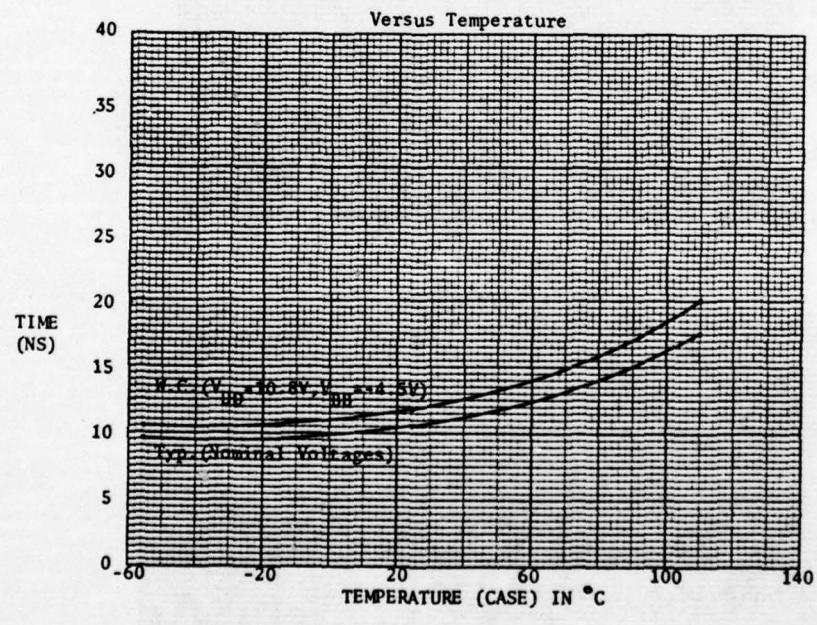
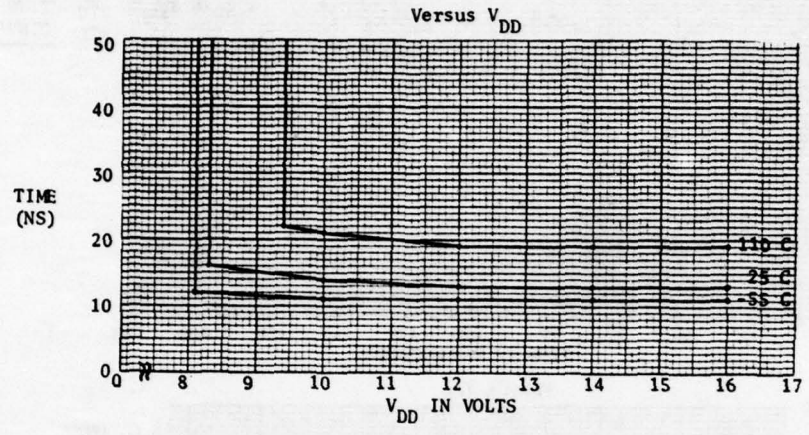

Vendor: B
 P/N: _____
 Rev.: (Shrink)
 Date Code: 7820

16K DYNAMIC RAM
COLUMN ADDRESS SETUP TIME
 t_{ASC}

By J.R.F. 6/8/78
 ADDR. PAT = Multiple
 DATA PAT = Multiple
 LOAD = NA
 $V_{BB} = -5.0V$
 $V_{CC} = 5.0V$
 $V_{IHC} = 2.7V$
 $V_{IH} = 2.4V$
 $V_{IL} = 0.8V$
 W.C. UNIT

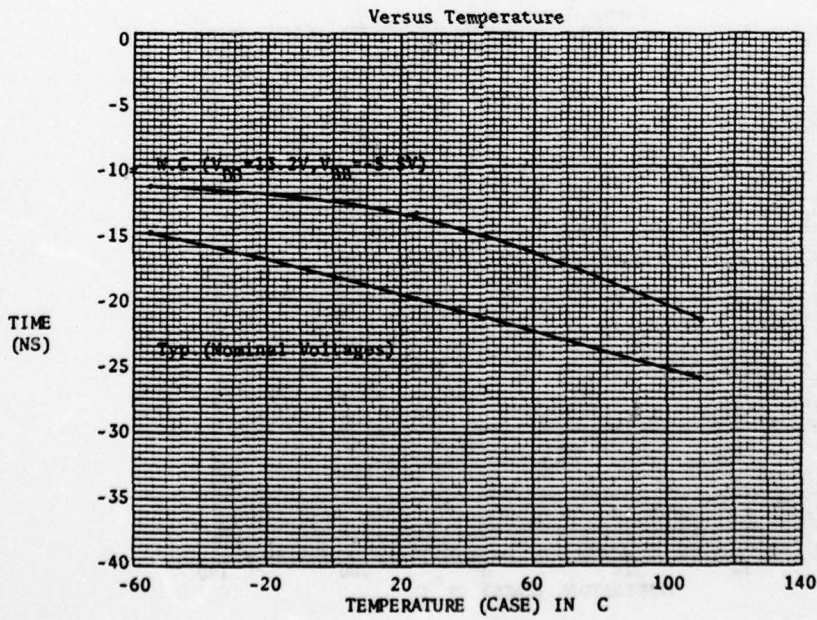
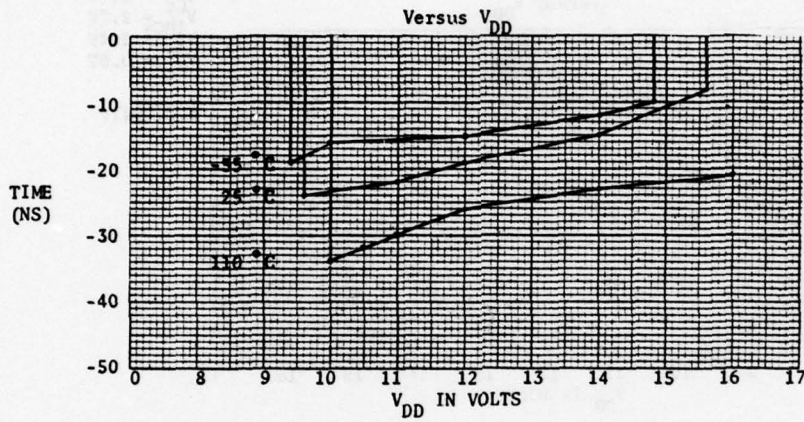

Vendor: B
P/N: _____
Rev.: (Shrink)
Date Code: 7820

16K DYNAMIC RAM
DATA IN SETUP TIME TO WRITE

By J.R.F. 6/7/78
ADDR. PAT = Multiple
DATA PAT = Multiple
LOAD = NA

$t_{DS(W)}$

$V_{BB} = -5.0V$
 $V_{CC} = 5.0V$
 $V_{THC} = 2.7V$
 $V_{IH} = 2.4V$
 $V_{IL} = 0.8V$

W.C. UNIT

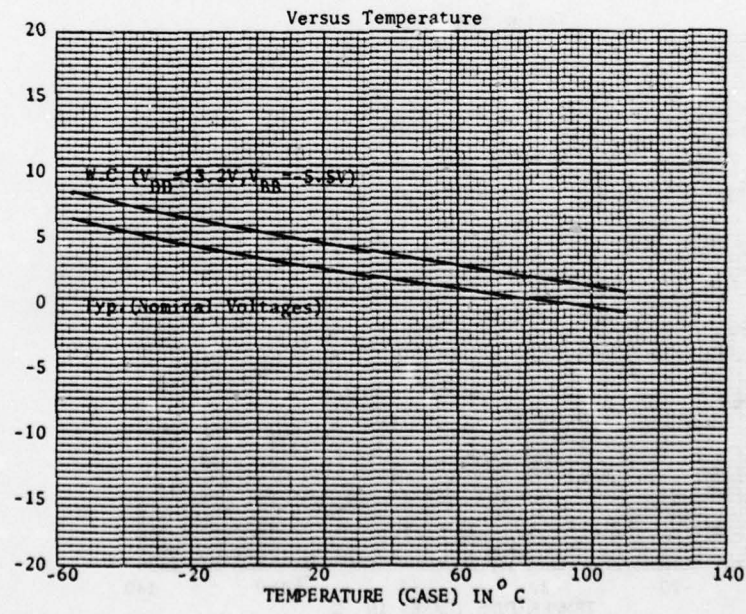
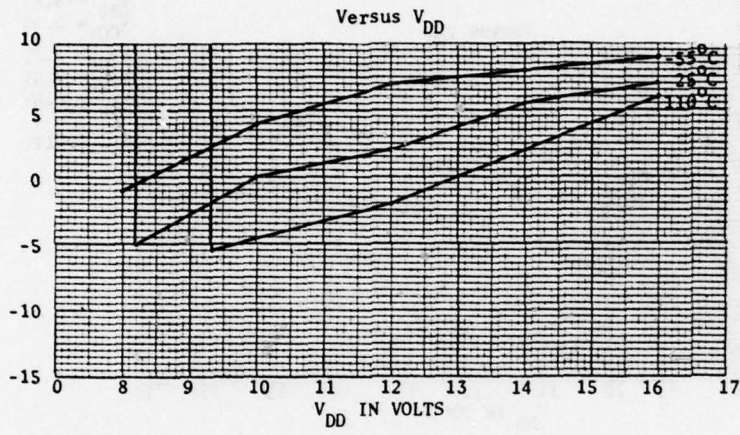

AD-A067 713

IBM FEDERAL SYSTEMS DIV OWEGO N Y
ELECTRICAL CHARACTERIZATION OF 16K DYNAMIC RAMS. (U)

F/G 9/2

UNCLASSIFIED

FEB 79 F D AUSTIN, J R FLORINI, E L HUNTER
RADC-TR-79-5

F30602-77-C-0222
NL

2 OF 2
ADA
067713

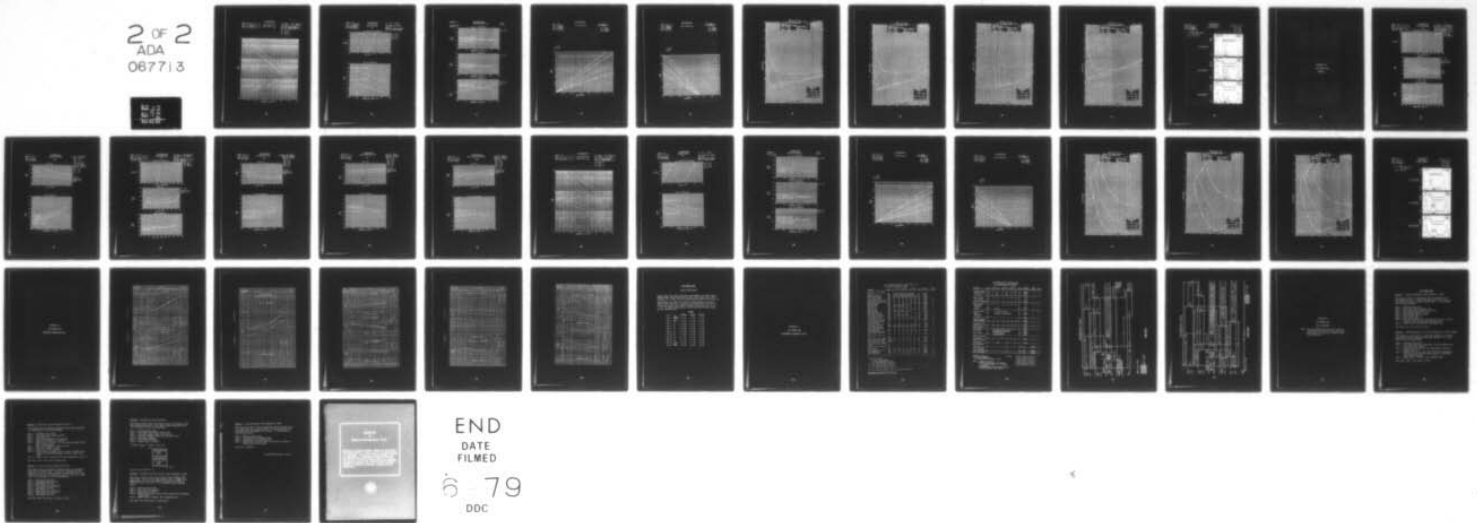

END
DATE
FILMED
6 79
DDC

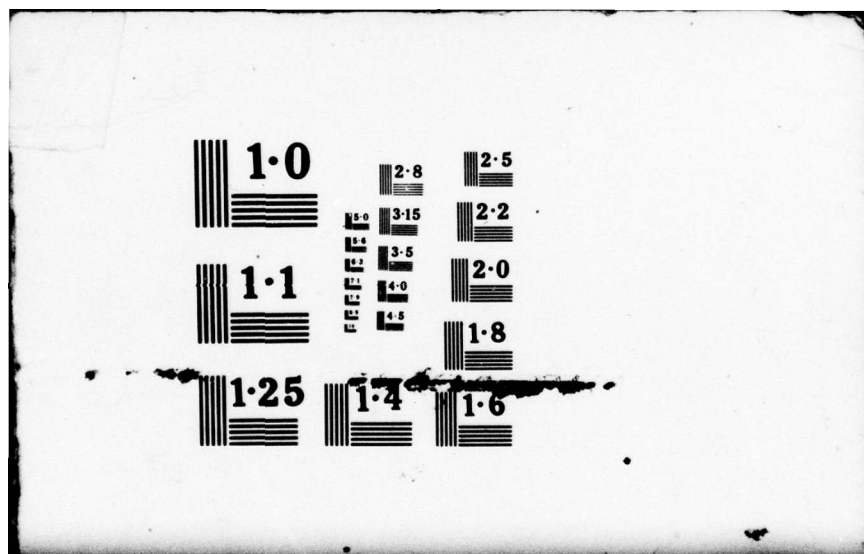

1·0

2·8

2·5

3·0
3·2
3·6
4·0
4·5

3·15

2·2

1·1

3·5

2·0

4·0

4·5

1·8

1·25

1·4

1·6

16K DYNAMIC RAM

Vendor: B
P/N: _____
REV: (Shrink)
Date Code: 7820

CELL RETENTION TIME
REFRESH PERIOD t_{REF}

By E.L.H. Date 7/12/78
 V_{DD} 10.8V V_{BB} -5.5V
ADDR. PAT. DYNAMIC REFRESH
DATA PAT. SINGLE X-BAR
 V_{IHC} 2.7V
 V_{IH} 2.4V
 V_{IL} 0.8V

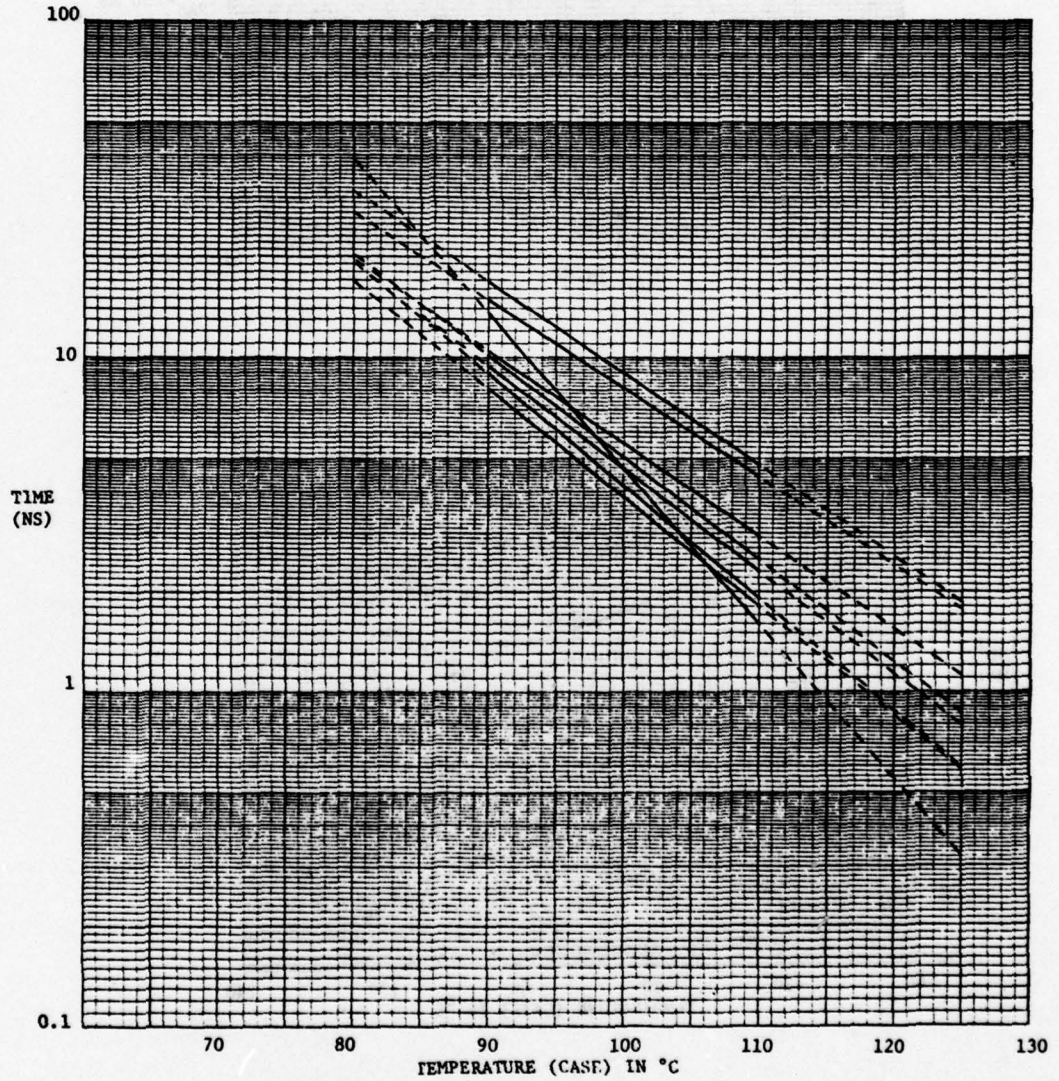

Vendor: B
 P/N: _____
 Rev.: (Shrink)
 Date Code: 7820
 No. Devices: 27

16K DYNAMIC RAM
 OPERATING CURRENT
 I_{DD1}

By J.R.F. 5/12/78
 $V_{BB} = -4.5V$ $V_{CC} = 5.0V$
 LOAD = NA
 ADDR.PAT. = WALKING DIAGONAL
 DATA PAT. = MAJOR DIAGONAL

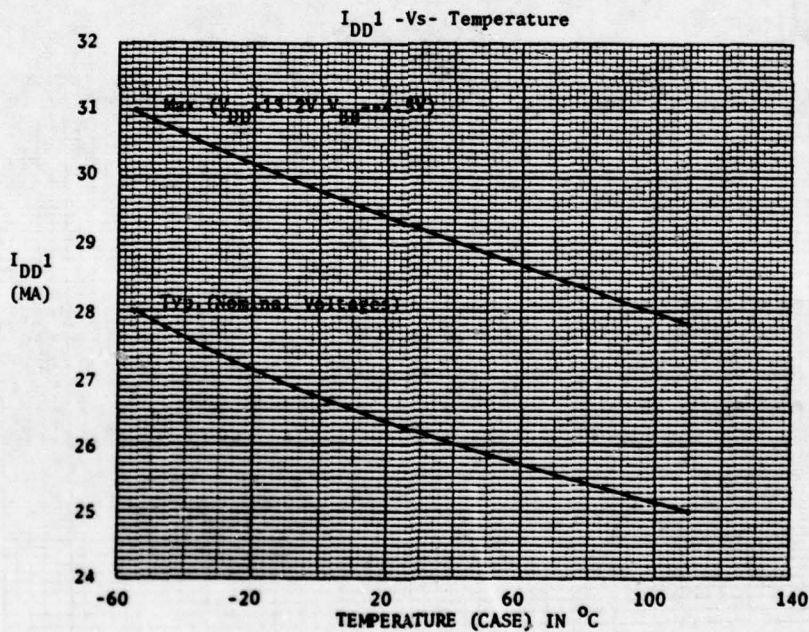
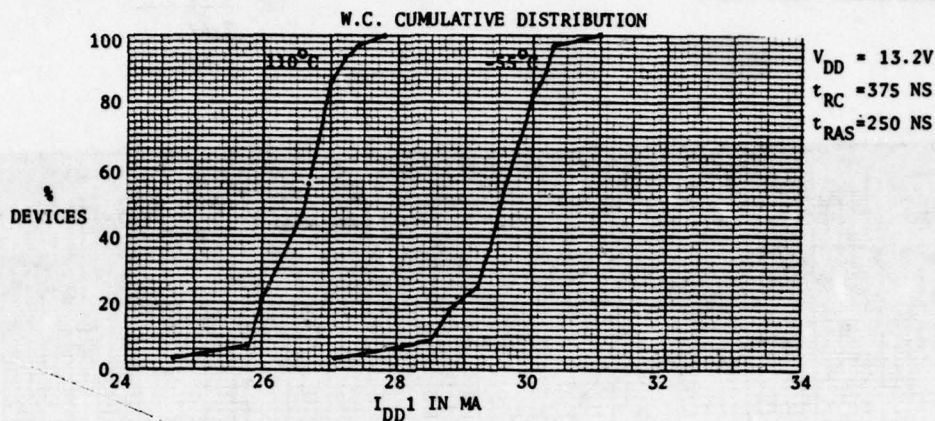

VENDOR B

16K DYNAMIC RAM
INPUT LEVEL SENSITIVITY

J.R.F.
6/6/78

Date Code 7820
(Shrink)

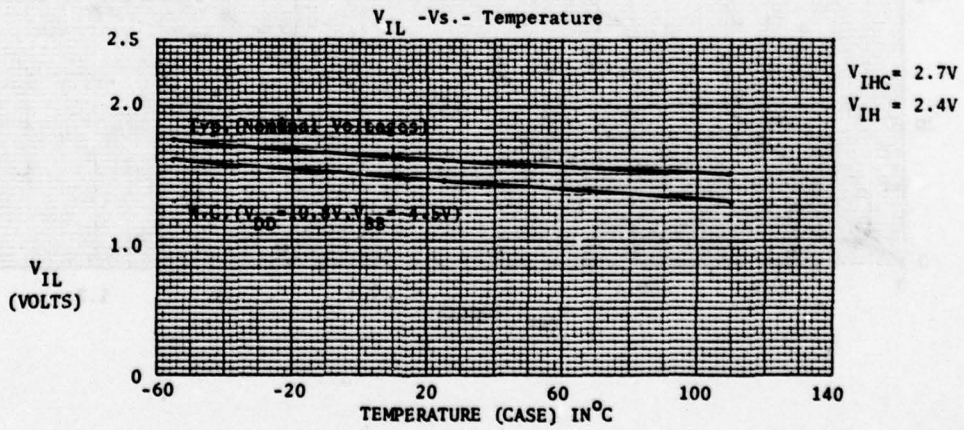
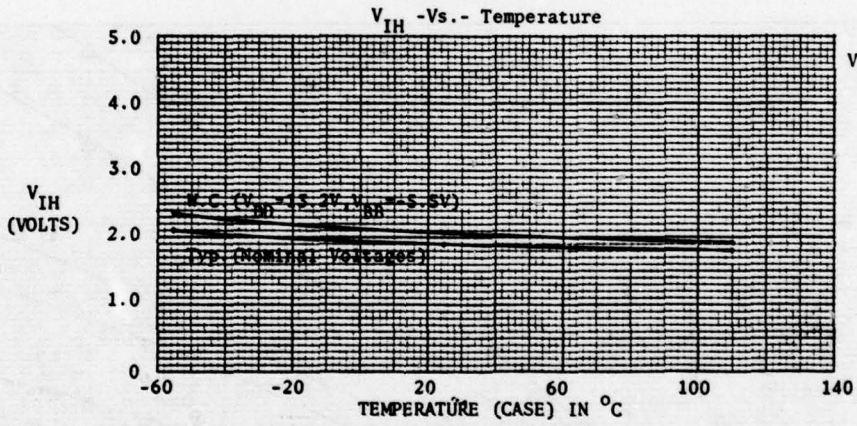
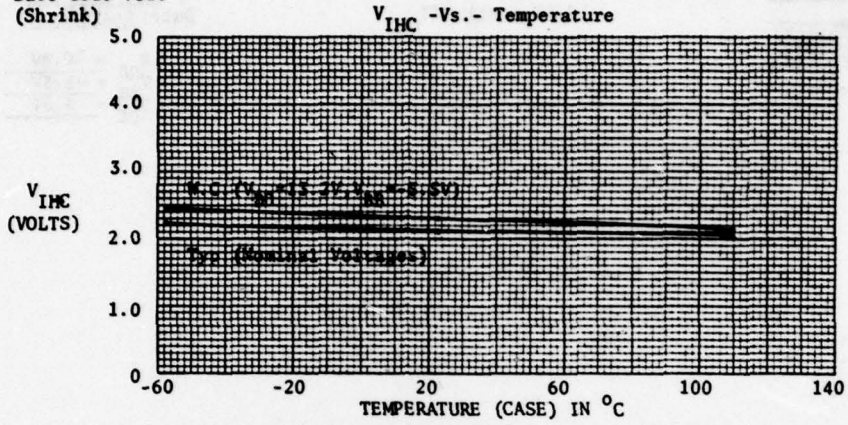

16K DYNAMIC RAM

Vendor: B
P/N: _____
REV.: (Shrink)
Date Code: 7820
DEV.: 7

SINK CURRENT (I_{OL})

By: J.R.F.
Date: 6/29/78

V_{DD} = 10.8V
 V_{BB} = -5.5V
 V_{CC} = 4.5V

• 25°C
○ 110°C
△ -55°C

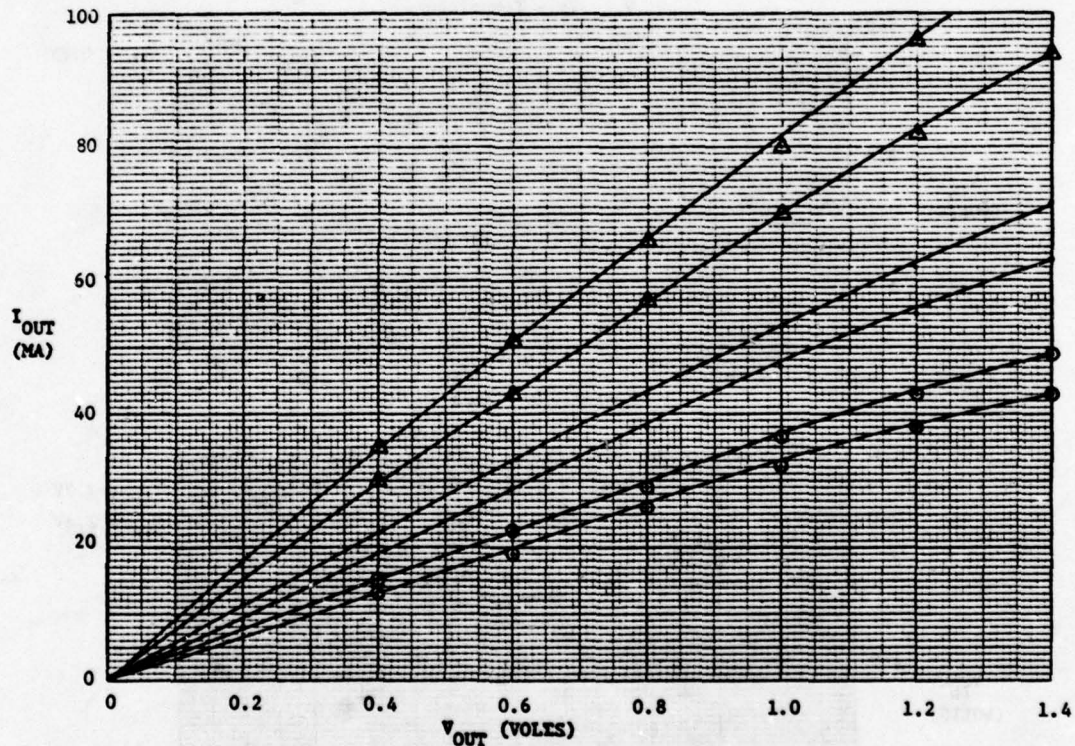

16K DYNAMIC RAM

Vendor: B
P/N: _____
REV.: (Shrink)
Date Code: 7820
DEV.: 7

SOURCE CURRENT (I_{OH})

By: J.R.F.
Date: 6/28/78

$V_{DD} = 10.8V$
 $V_{BB} = -2.5V$
 $V_{CC} = 4.5V$

• 25°C
○ 110°C
△ -55°C

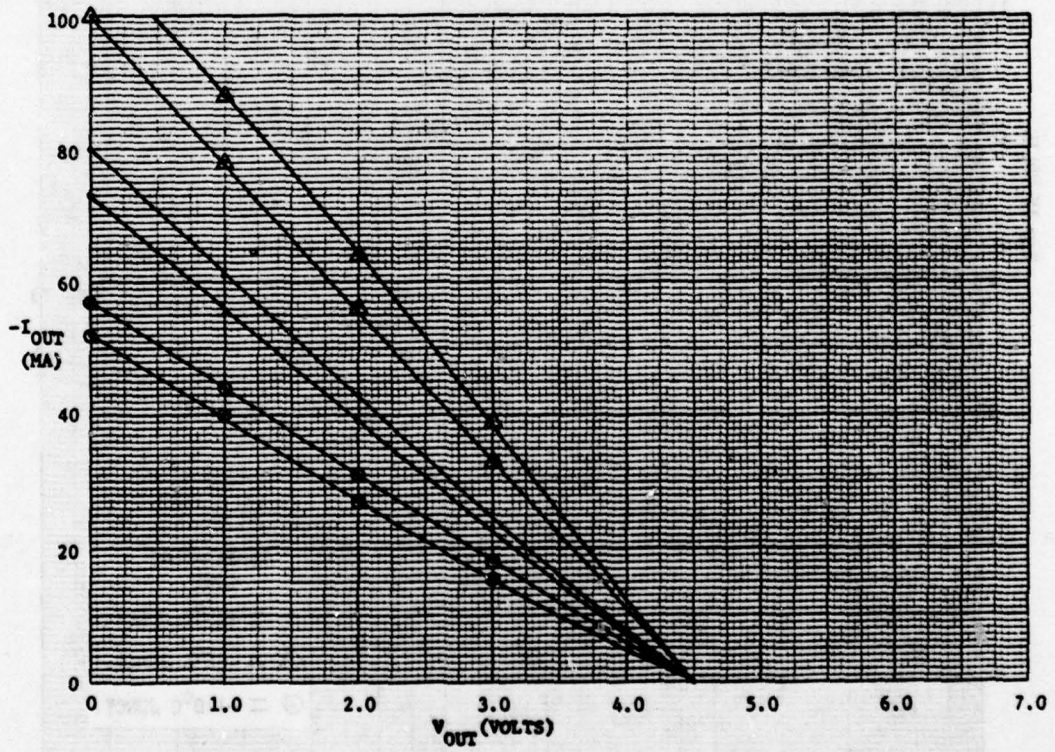

SHMOO V_{DD} -VS- V_{BB}

DATE 5/30/78

PART TYPE 16K DYNAMIC RAM
VENJOR P/N B
DATE CODE 7820 (SHRINK)
 V_{CC} = 5.0V
CYCLE = 375NS
TRAC = 200NS
PATTERN = GAL.
DATA = 1/0
 V_{INC} = 2.7V
 V_{IN} = 2.4V V_{IL} = 0.8V

MINI # 3

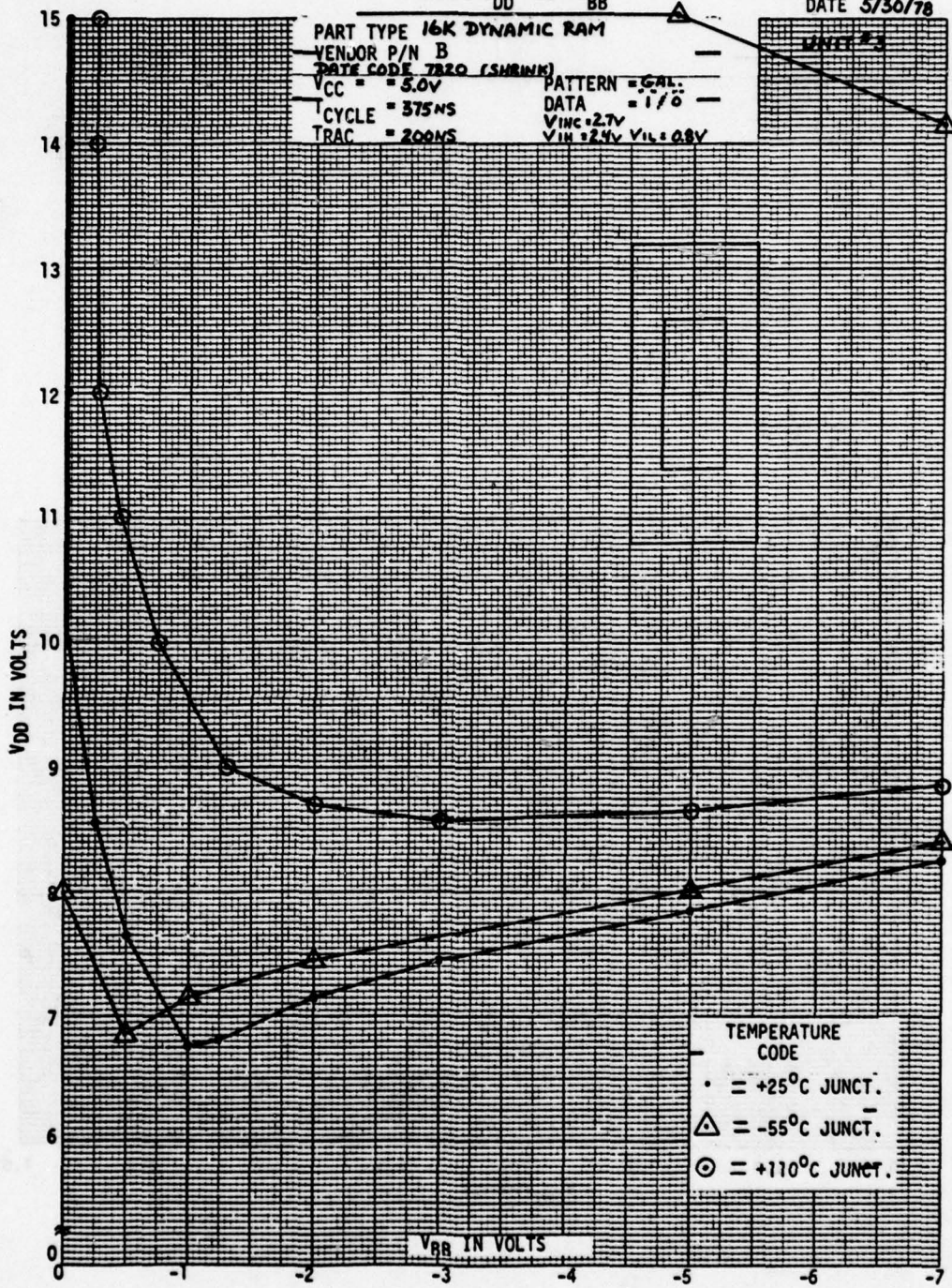

SHMOO V_{DD} -VS- V_{BB}

DATE 5/31/78

PART TYPE 16K DYNAMIC RAM
VENDOR P/N B
DATE CODE 7820 (SHRINK)
 $V_{CC} = 5.0V$
CYCLE = 375NS
TRAC = 200NS
PATTERN = GAL.
DATA = 110
 $V_{INC} = 2.7V$
 $V_{IH} = 2.4V$ $V_{IL} = 0.8V$

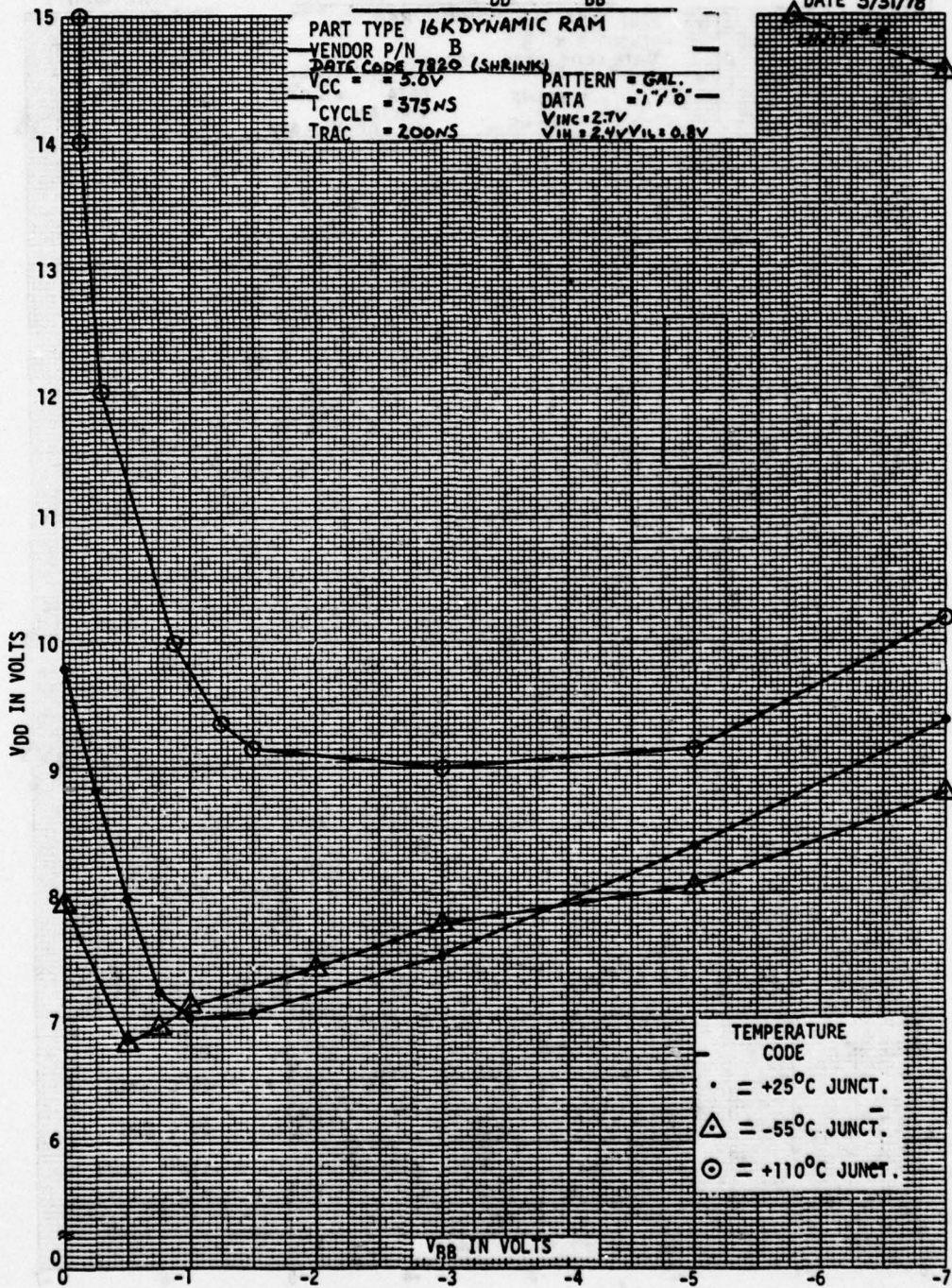

TEMPERATURE CODE
• = +25°C JUNCT.
△ = -55°C JUNCT.
⊙ = +110°C JUNCT.

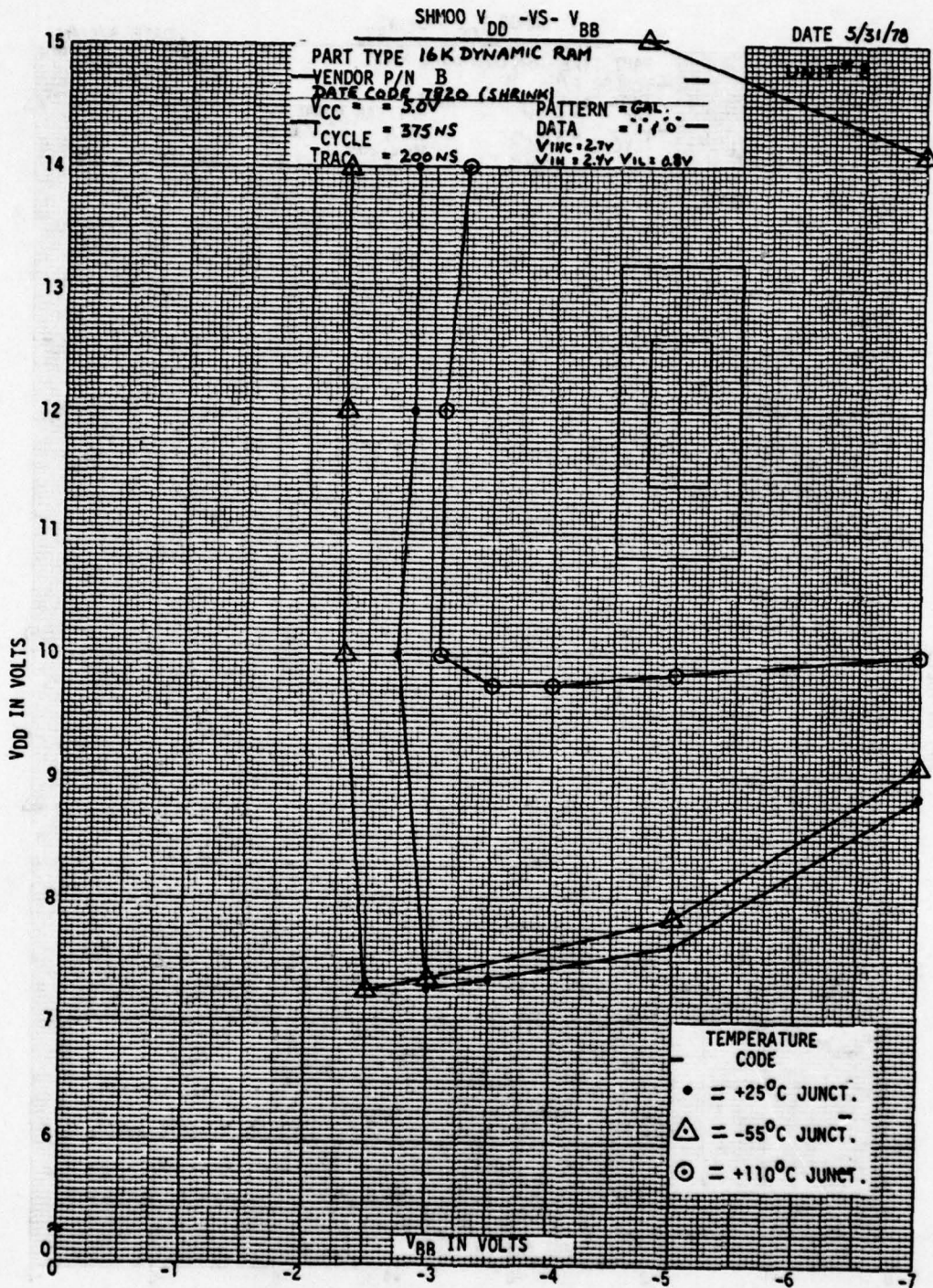

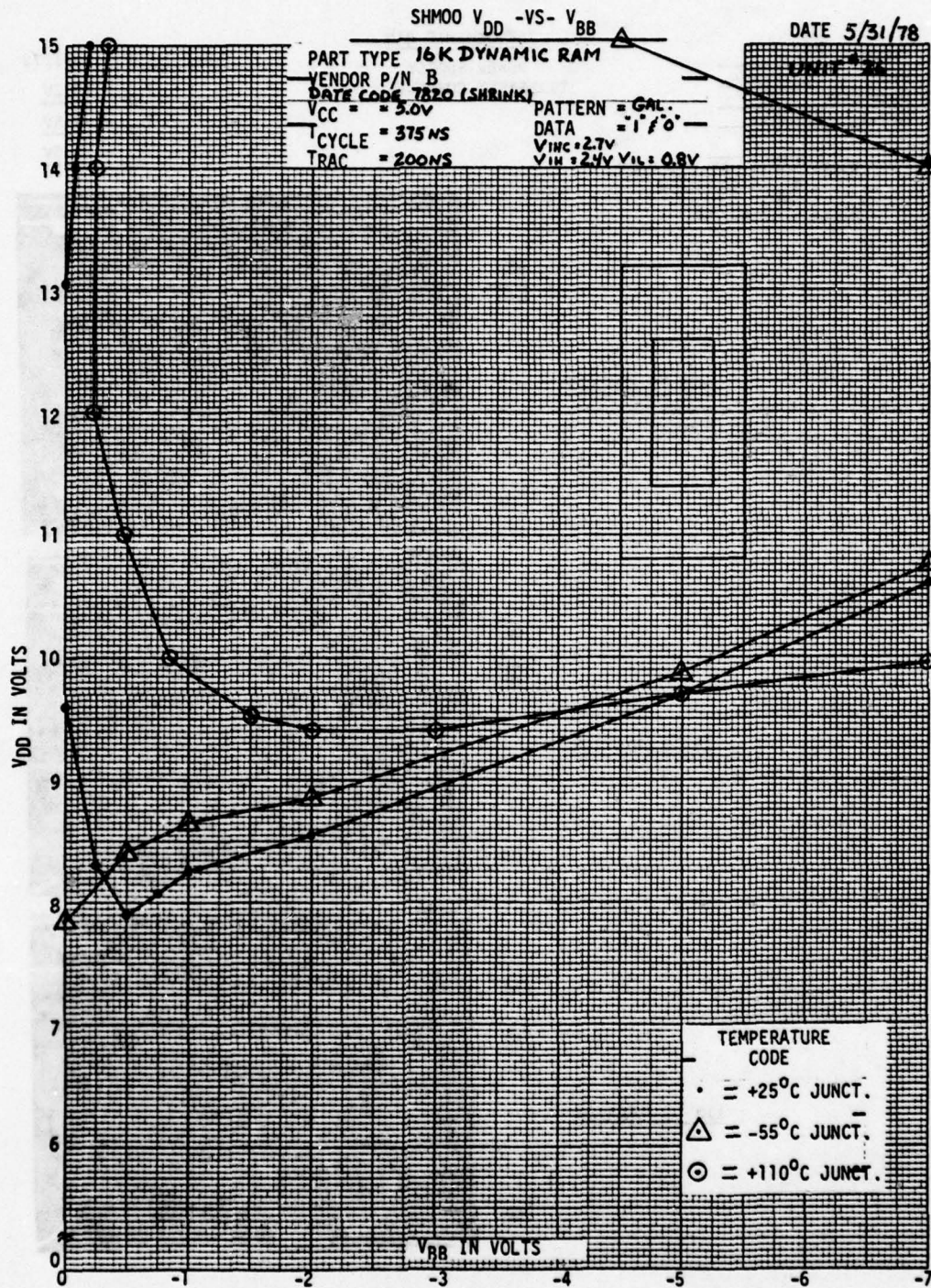

VENDOR: B
P/N: _____
Date Code: 7820
Rev.: (SHRINK)

16K DYNAMIC RAM
POWER SUPPLY
TRANSIENT CURRENTS

By: J.R.F. 6/1/78

$V_{DD} = 13.2V$
 $V_{BB} = -4.5V$
 $V_{CC} = 5.0V$

Vert.: \overline{RAS} & $\overline{CAS} = 1 V/CM$
 $I_{DD} = 20 MA/CM$
Horiz.: 50 NS/CM

-55 °C JUNCTION

\overline{RAS}
 \overline{CAS}

I_{DD}

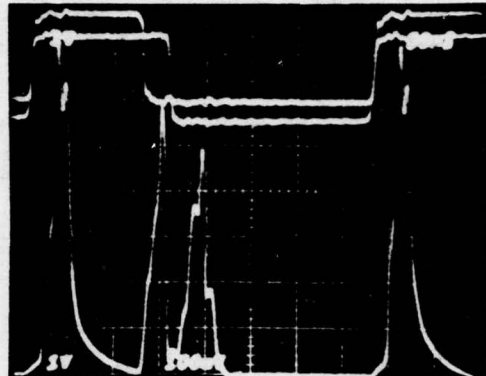

25 °C JUNCTION

\overline{RAS}
 \overline{CAS}

I_{DD}

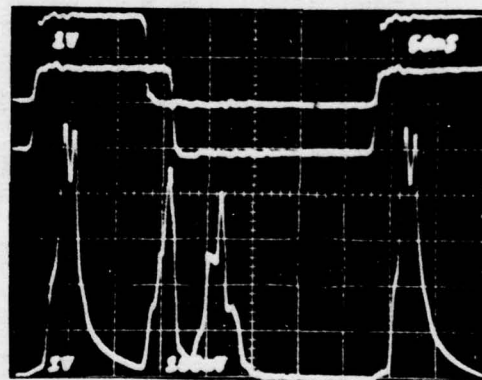

110 °C JUNCTION

\overline{RAS}
 \overline{CAS}

I_{DD}

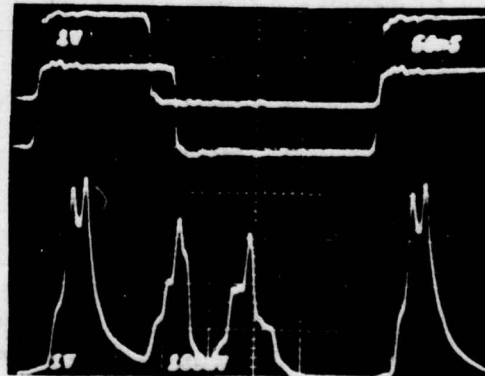

APPENDIX III
16K DYNAMIC RAM
VENDOR C

Vendor: C
 P/N: _____
 REV: _____
 Date Code: 0278
 # Device: 25

16K DYNAMIC RAM
 ACCESS TIME FROM CAS
 t_{CAC}

By J.R.F. Date 6/8/78
 V_{BB} -4.5V V_{CC} 5.0V
 LOAD 1 Schottky TTL * 50pF
 ADDR PAT. Multiple
 DATA PAT. Multiple

W.C. CUMULATIVE DISTRIBUTION:

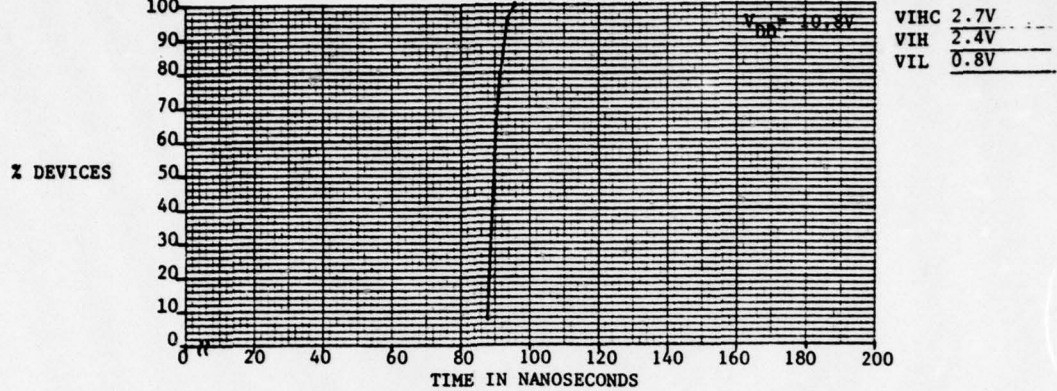

$V_{DD} = 10.8V$
 $V_{IH} = 2.7V$
 $V_{IL} = 0.8V$

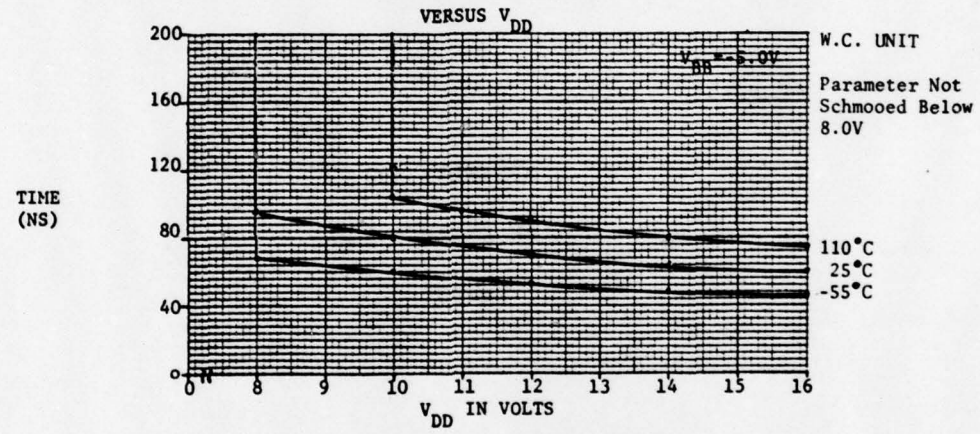

W.C. UNIT
 Parameter Not Schmoored Below 8.0V

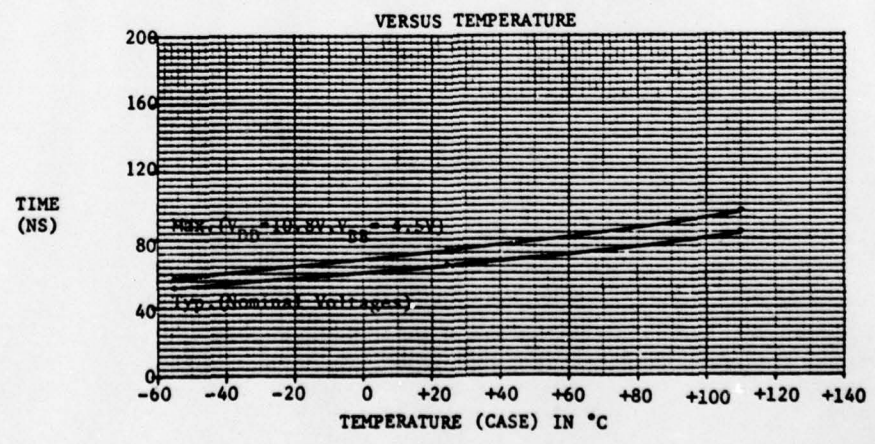

Vendor: C
 P/N: _____
 Rev: _____
 Date Code: 0278

16K DYNAMIC RAM
ACCESS TIME FROM RAS

By J.R.F Date 6/8/78

$V_{BB} = -5.0V$
 $V_{CC} = 5.0V$
 LOAD= 1 Schottky
 TTL + 50pF
 ADDR.PAT = Multiple
 DATA PAT = Multiple
 $V_{IHC} = 2.7V$
 $V_{IH} = 2.4V$
 $V_{IL} = 0.8V$

t_{RAC}

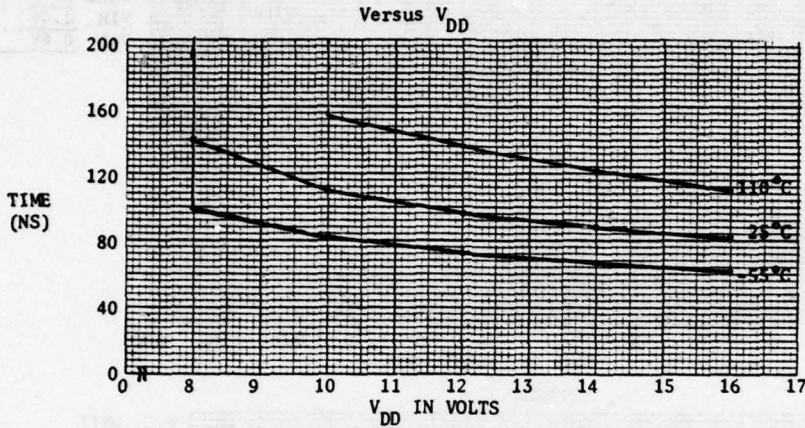

W.C. UNIT
 Parameter Not
 Schmoosed Below
 8.0V

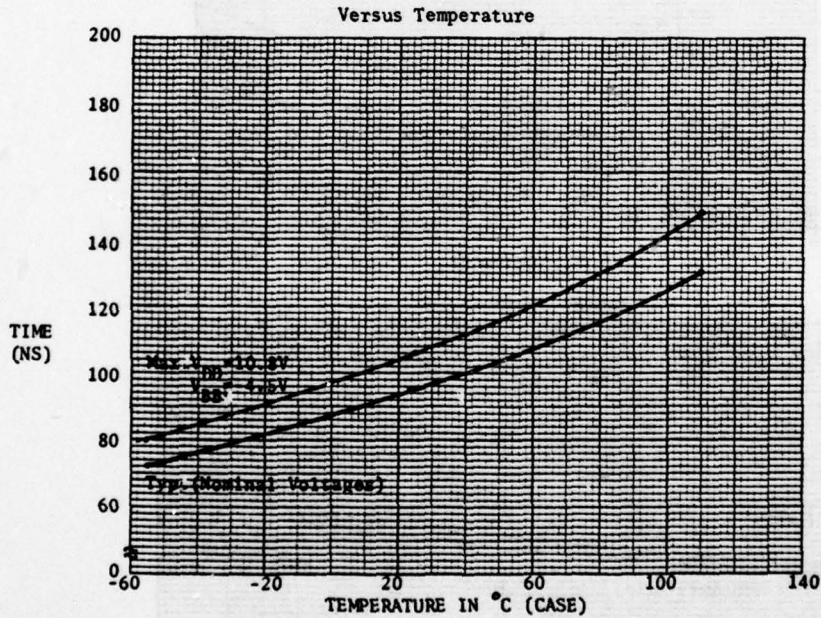

Vendor: C
 P/N: _____
 REV: _____
 Data Code: 0278
 # Device: 25

16K DYNAMIC RAM
RAS PRECHARGE TIME
 t_{RP}

By J.R.F. Date 5/25/78
 V_{BB} -4.5V V_{CC} 5.0V
 LOAD NA
 ADDR PAT. Multiple
 DATA PAT. Multiple

W.C. CUMULATIVE DISTRIBUTION:

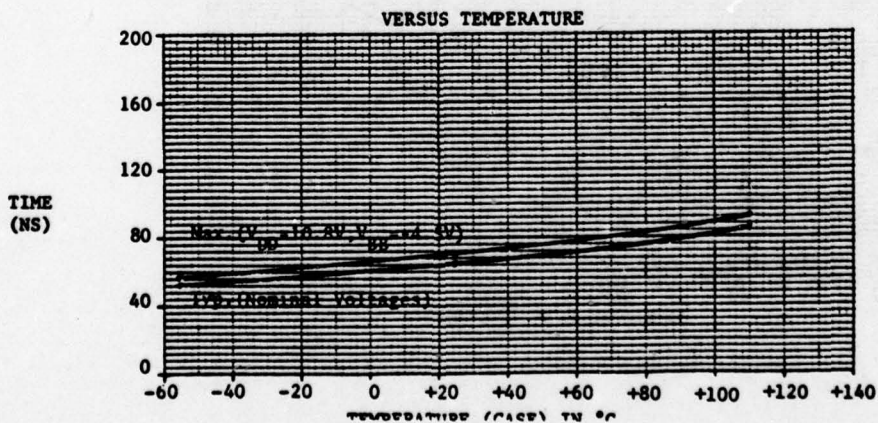
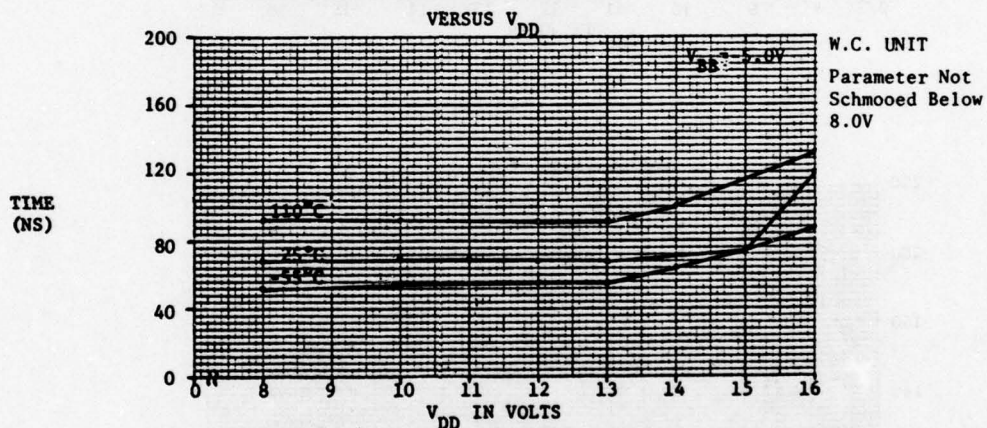
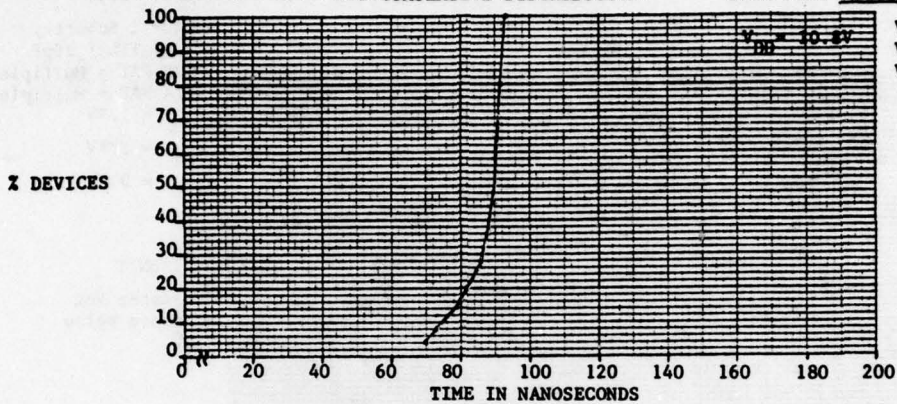

Vendor: C
 P/N: _____
 Rev.: _____
 Date Code: 0278

16K DYNAMIC RAM
 ROW ADDRESS HOLD TIME

By J.R.F. Date 6/8/78
 ADDR. PAT = Multiple
 DATA PAT = Multiple
 LOAD = NA
 $V_{BB} = -5.0V$
 $V_{CC} = 5.0V$
 $V_{IHC} = 2.7V$
 $V_{IH} = 2.4V$
 $V_{IL} = 0.8V$

t_{RAH}

Versus V_{DD}

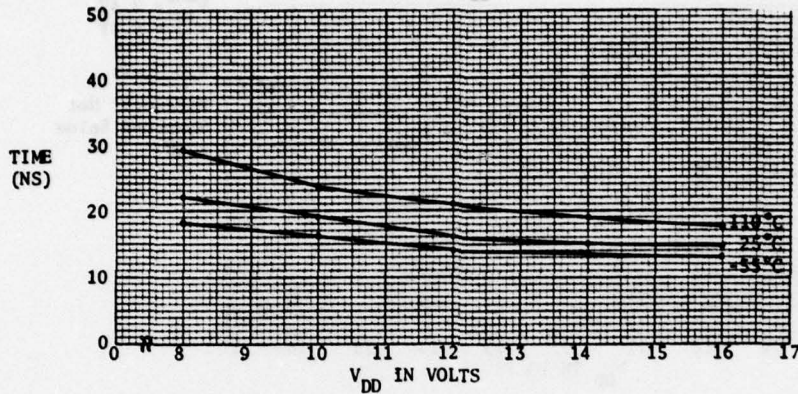

W.C. UNIT
 Parameter Not
 Schmoosed Below
 8.0V

Versus Temperature

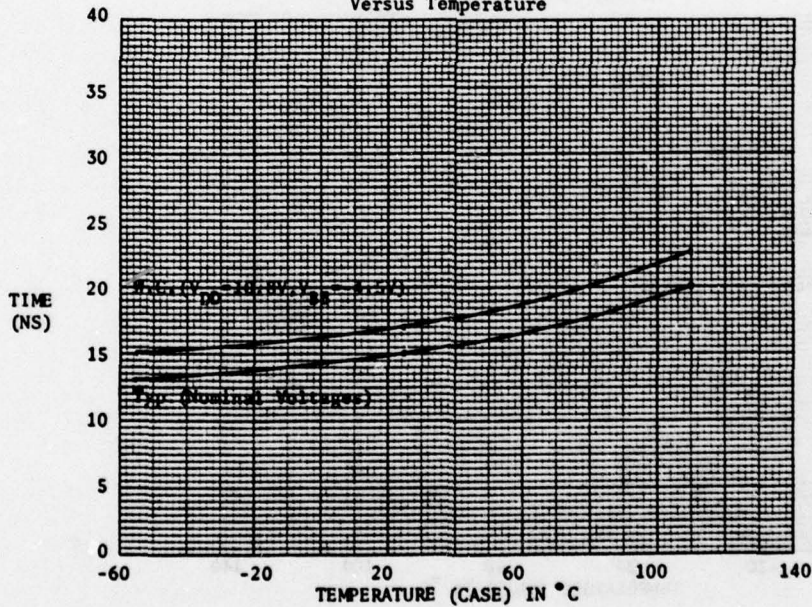

Vendor: C
P/N: _____
Rev.: _____
Date Code: 0278

16K DYNAMIC RAM
COLUMN ADDRESS SETUP TIME
 t_{ASC}

By J.R.F. 6/8/78
ADDR.PAT = Multiple
DATA PAT = Multiple
LOAD = NA
 $V_{BB} = -5.0V$
 $V_{CC} = 5.0V$
 $V_{IHC} = 2.7V$
 $V_{IH} = 2.4V$
 $V_{IL} = 0.8V$

W.C. unit
Parameter Not
Schmoosed Below
8.0W

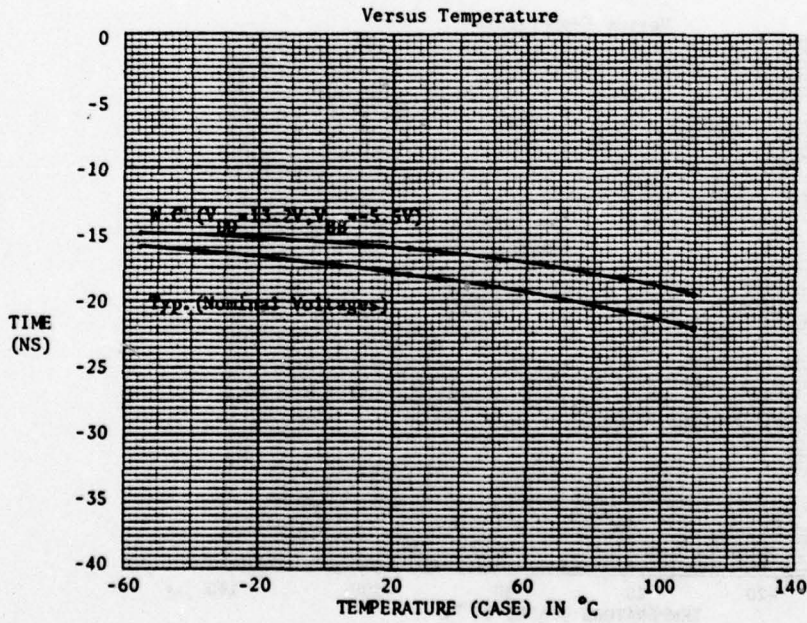
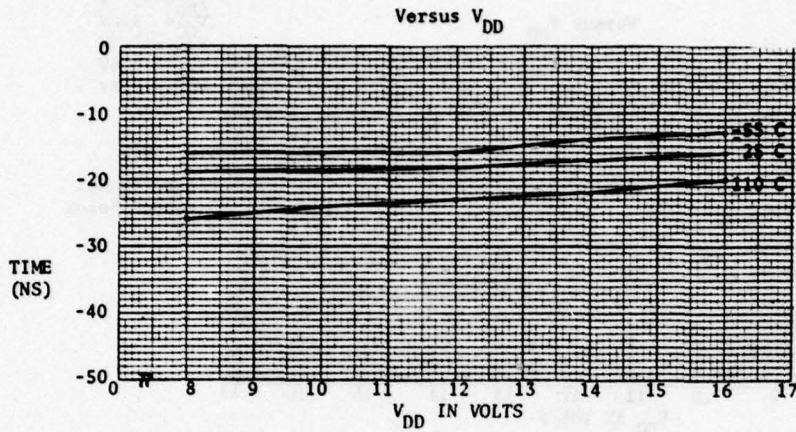

Vendor: C
P/N:
Rev.:
Date Code: 0278

16K DYNAMIC RAM
DATA IN SETUP TIME TO WRITE
 $t_{DS(W)}$

By J.R.F. 6/8/78
ADDR.PAT = Multiple
DATA PAT = Multiple
LOAD = NA
 $V_{BB} = -5.0V$
 $V_{CC} = 5.0V$
 $V_{IHC} = 2.7V$
 $V_{IH} = 2.4V$
 $V_{IL} = 0.8V$
W.C. UNIT
Parameter Not
Schmoode Below
8.0V

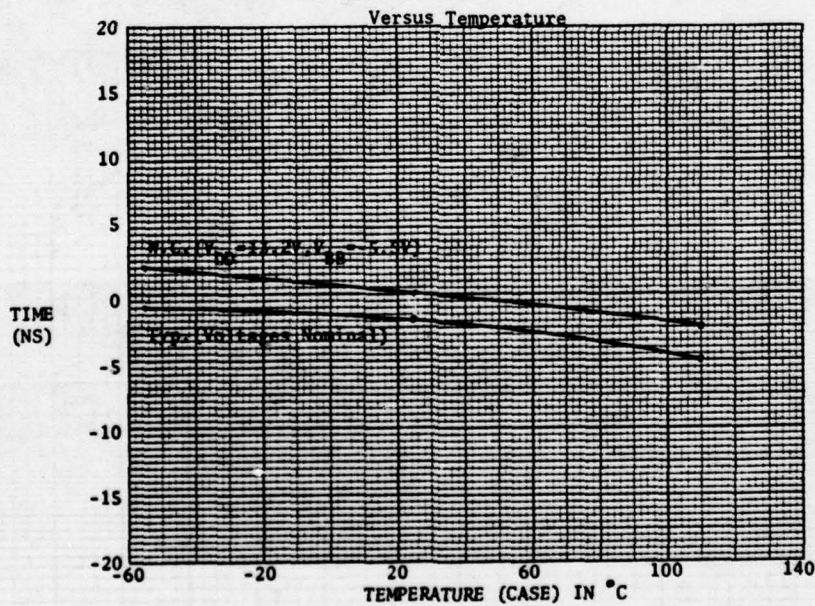
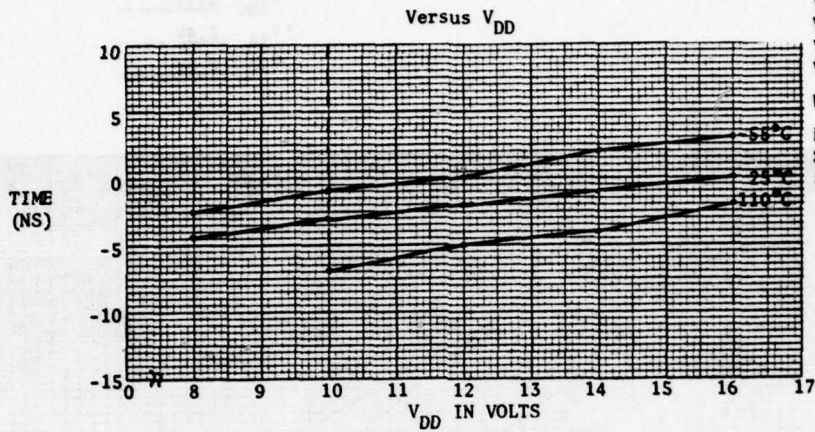

16K DYNAMIC RAM

Vendor: C
P/N: _____
REV: _____
Date Code: 0278

CELL RETENTION TIME
REFRESH PERIOD t_{REF}

By E.L.H. Date 7/12/78
 V_{DD} 10.8V V_{BB} -5.5V
ADDR. PAT. DYNAMIC REFRESH
DATA PAT. SINGLE X-BAR
 V_{IHC} 2.7V
 V_{IH} 2.4V
 V_{IL} 0.8V

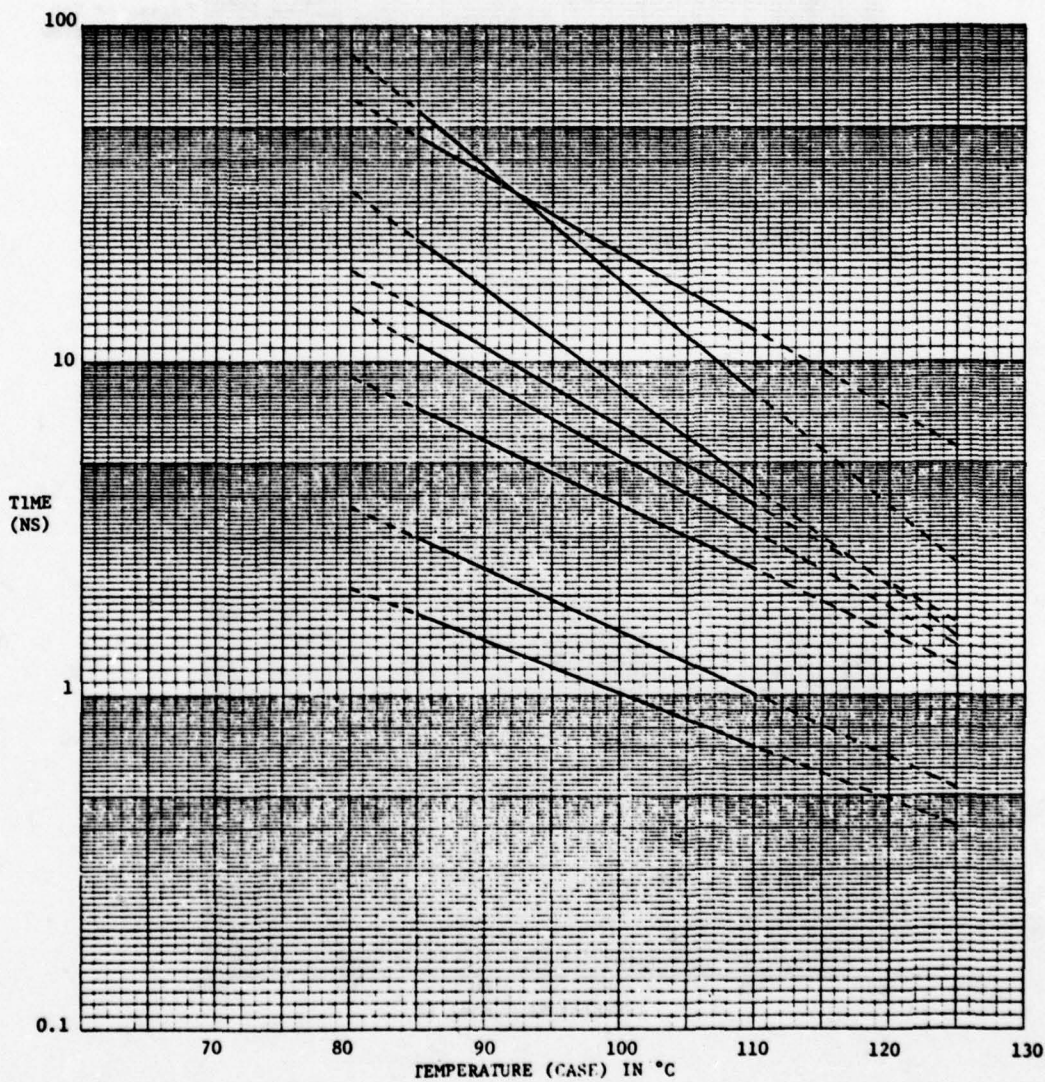

Vendor: C
 P/N: _____
 Rev.: _____
 Date Code: 0278
 No. Devices: 25

16K DYNAMIC RAM
 OPERATING CURRENT
 I_{DD1}

By J.R.F. 5/17/78
 $V_{BB} = -4.5V$ $V_{CC} = 5.0V$
 LOAD = NA
 ADDR. PAT. = WALKING DIAGONAL
 DATA PAT. = MAJOR DIAGONAL

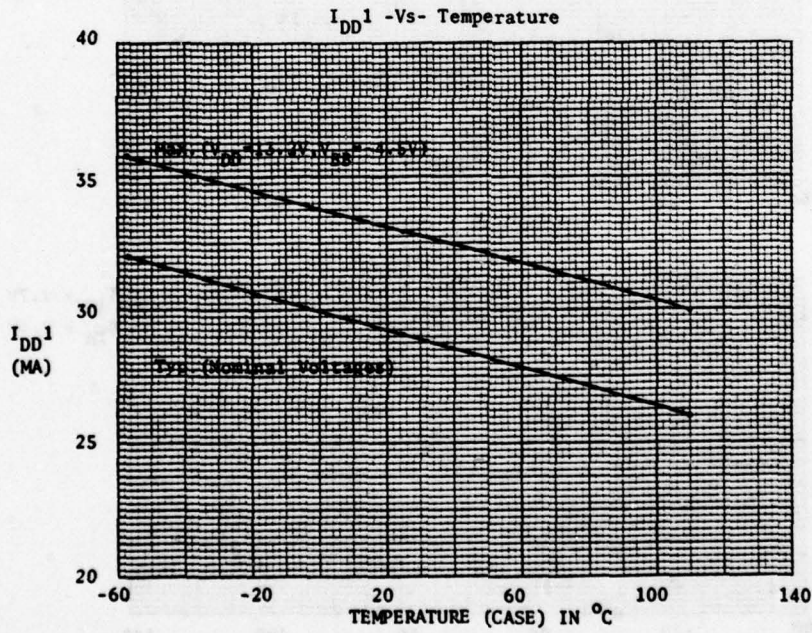
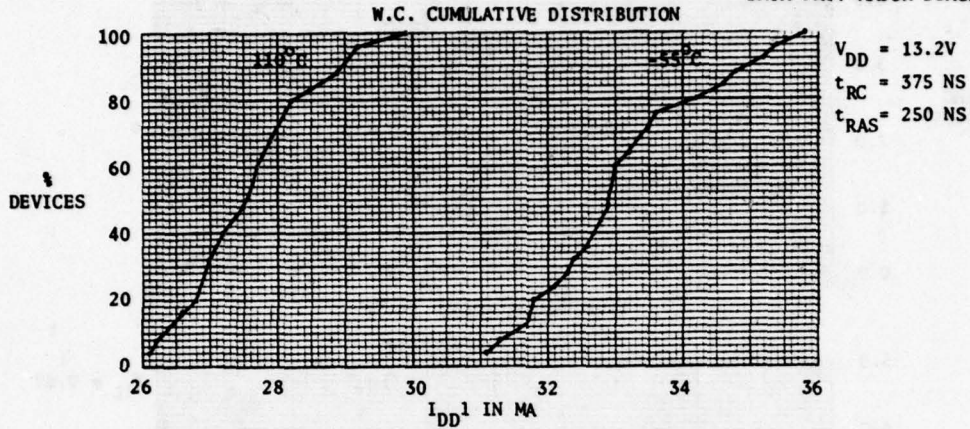

VENDOR C

16K DYNAMIC RAM
INPUT LEVEL SENSITIVITY

J.R.F.
6/19/78

Date Code 0278

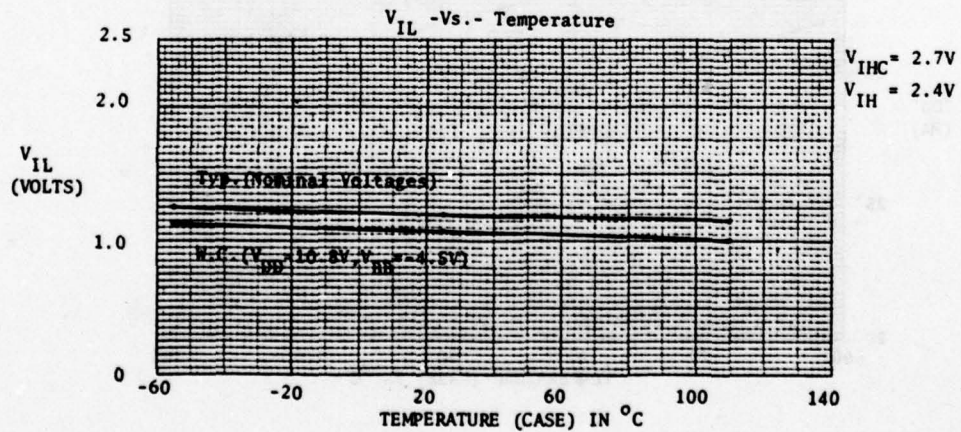
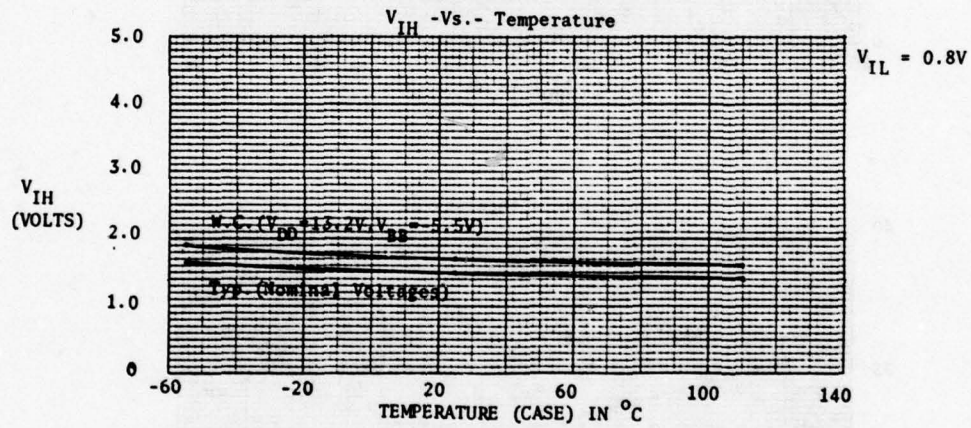
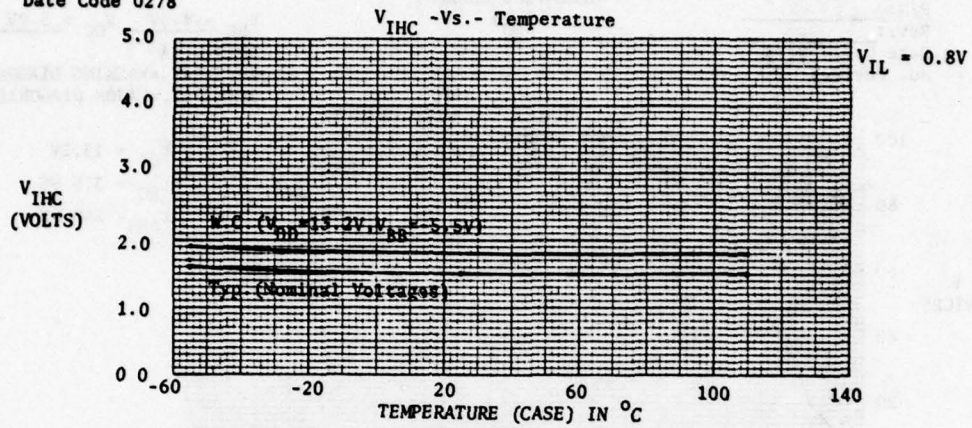

16K DYNAMIC RAM

Vendor: C
P/N: _____
REV.: _____
Date Code: 0278
DEV.: 7

SINK CURRENT (I_{OL})

By: J.R.F.
Date: 6/29/78

V_{DD} = 10.8V
 V_{BB} = -5.5V
 V_{OC} = 4.5V

• 25°C
⊙ 110°C
△ -55°C

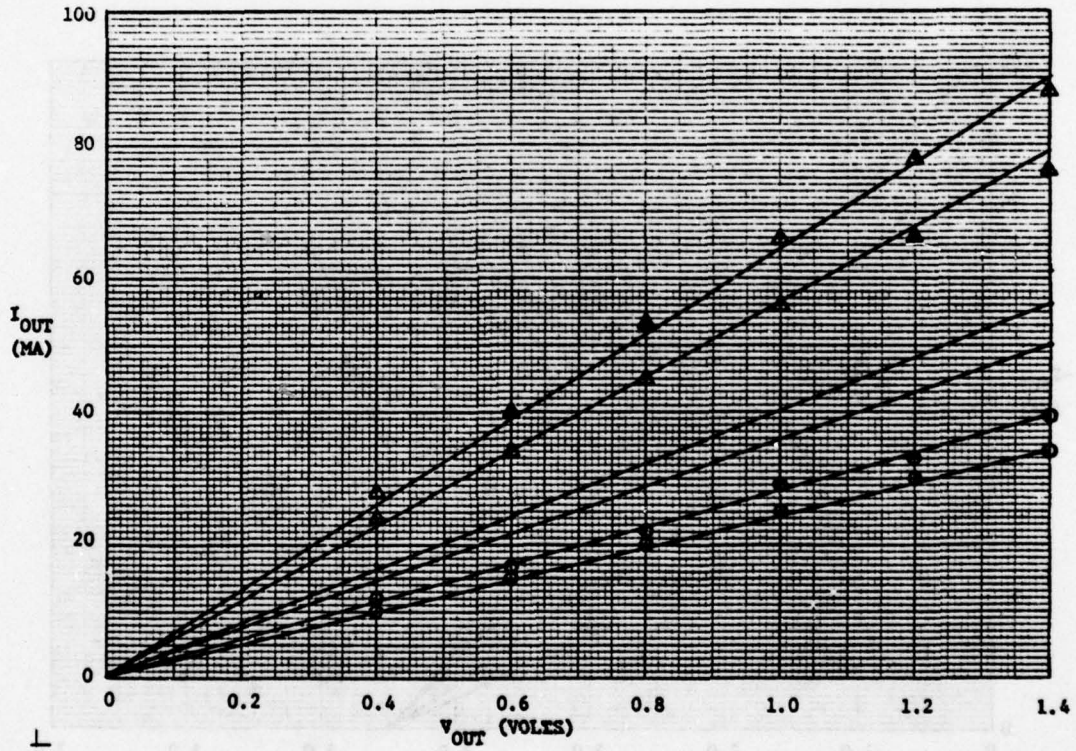

16K DYNAMIC RAM

Vendor: C
P/N: _____
REV.: _____
Date Code: 0278
DEV.: 7

SOURCE CURRENT (I_{OH})

By: J.R.F.
Date: 6/28/78

$V_{DD} = 10.8V$
 $V_{BB} = -5.5V$
 $V_{CC} = 4.5V$

• 25°C
○ 110°C
△ -55°C

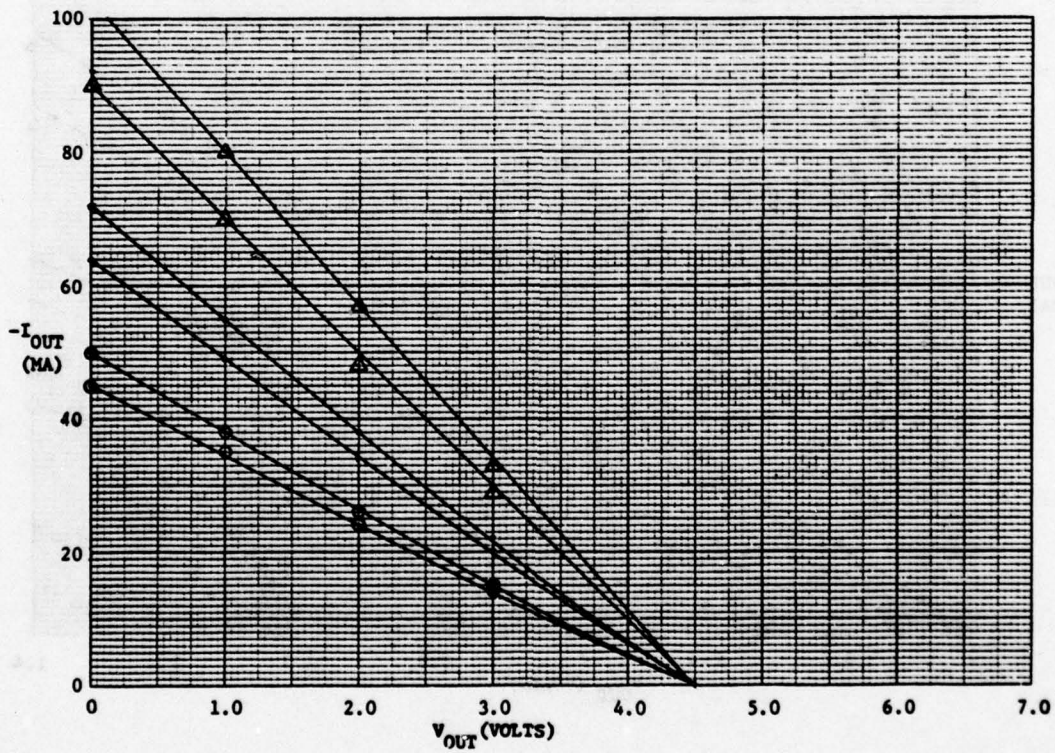

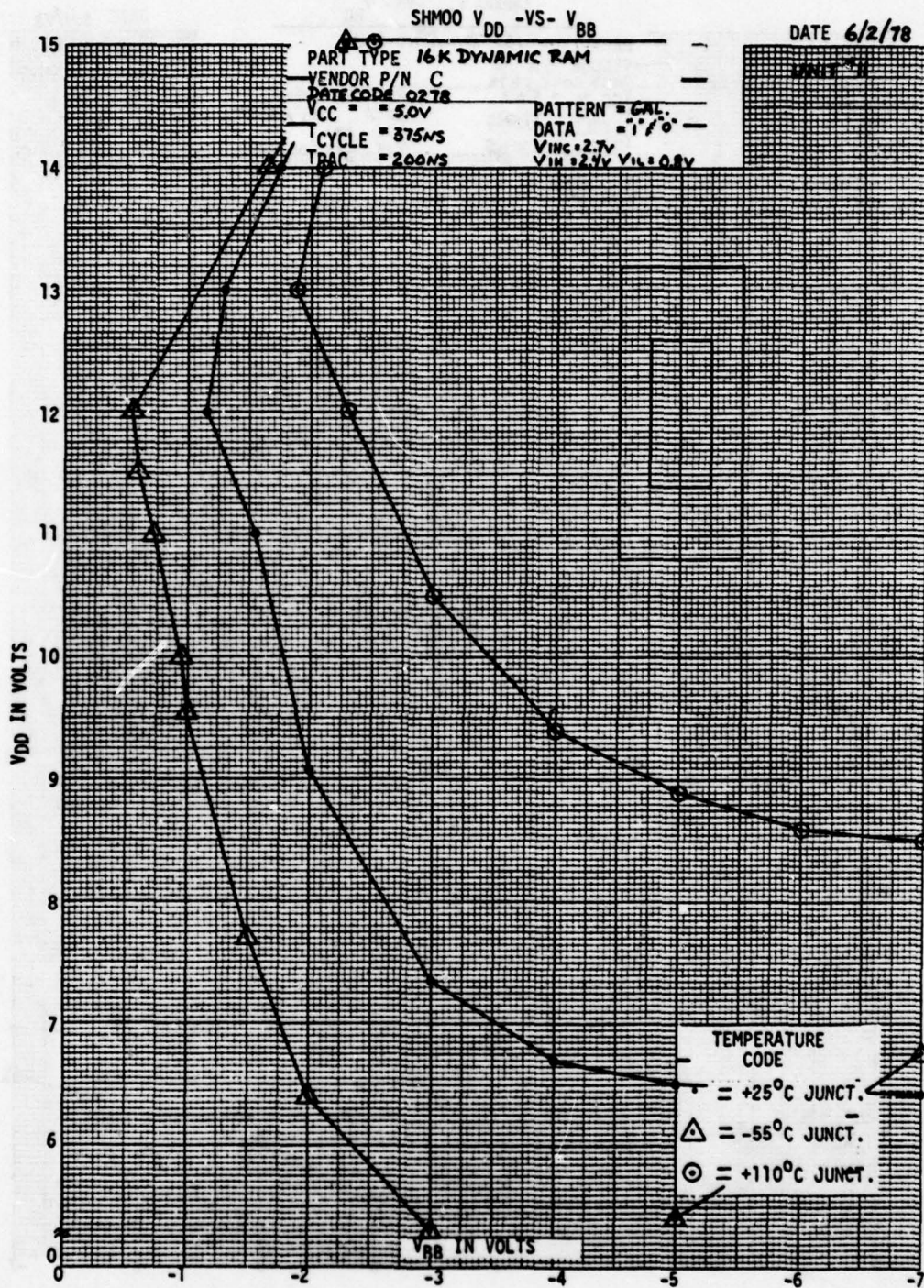

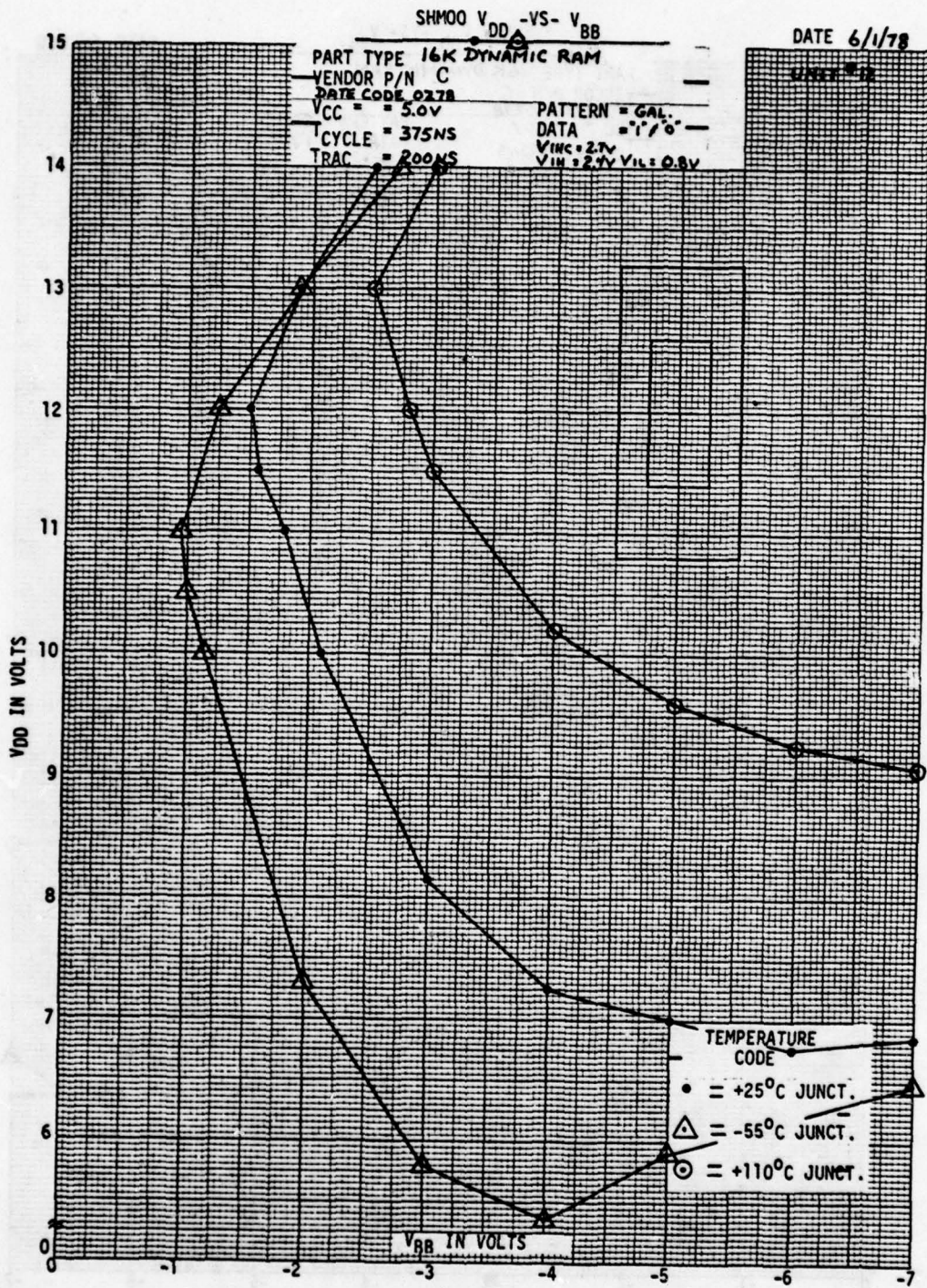

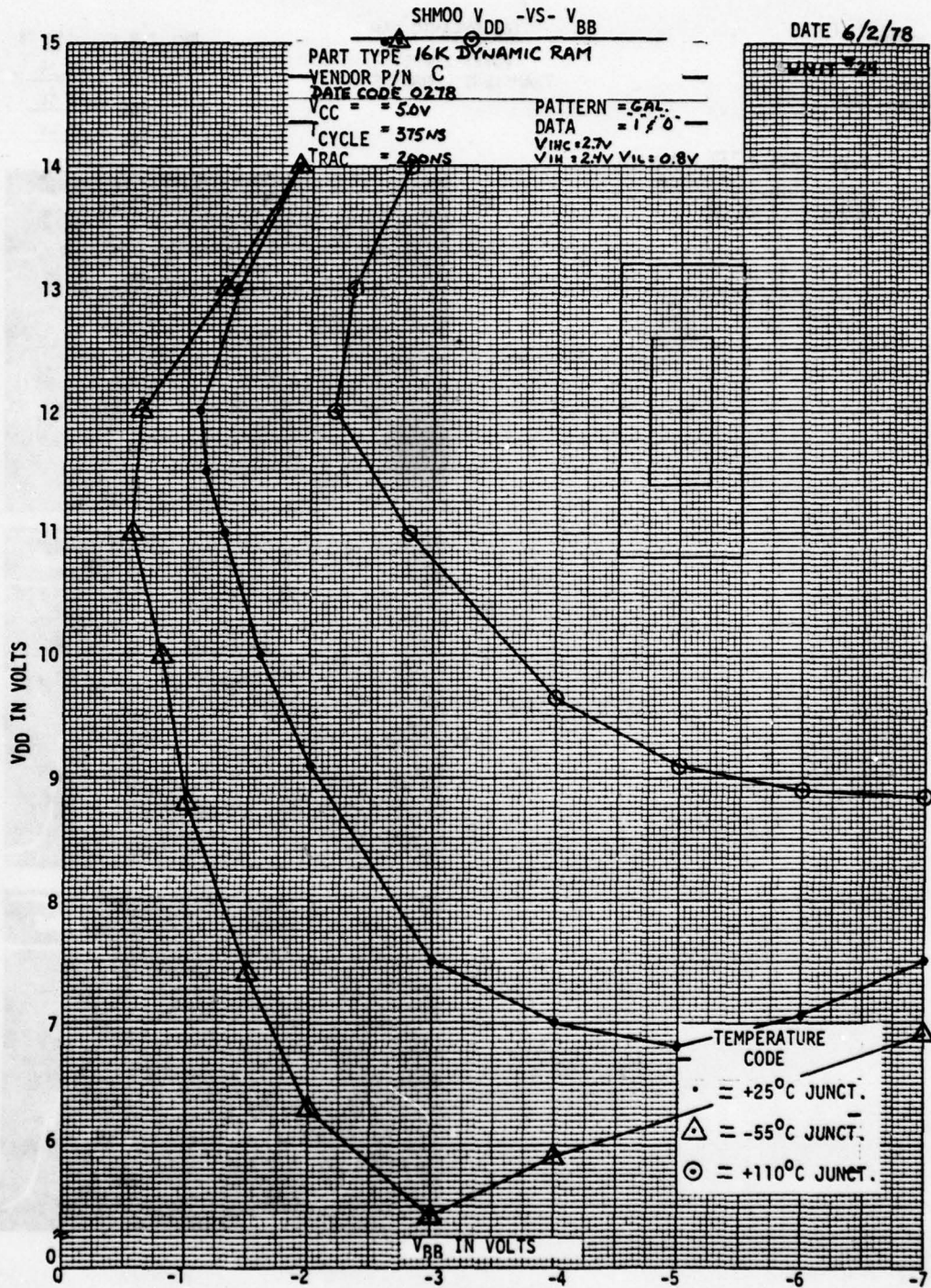

VENDOR: C
P/N: _____
Rev.: _____
Date Code: 0278

16K DYNAMIC RAM
POWER SUPPLY
TRANSIENT CURRENTS

By: J.R.F. 6/2/78

$V_{DD} = 13.2V$
 $V_{BB} = -4.5V$
 $V_{CC} = 5.0V$

Vert.: \overline{RAS} & $\overline{CAS} = 1 V/CM$
 $I_{DD} = 20 MA/CM$
Horiz.: 50 NS/CM

-55 °C JUNCTION

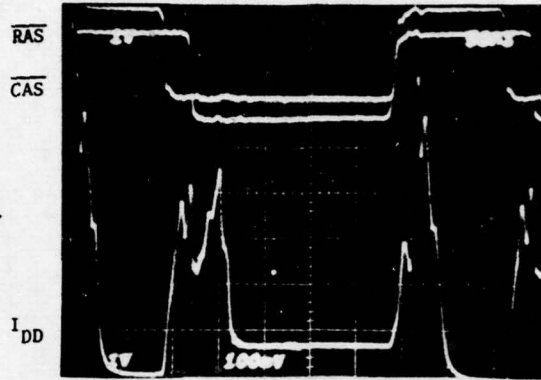

25 °C JUNCTION

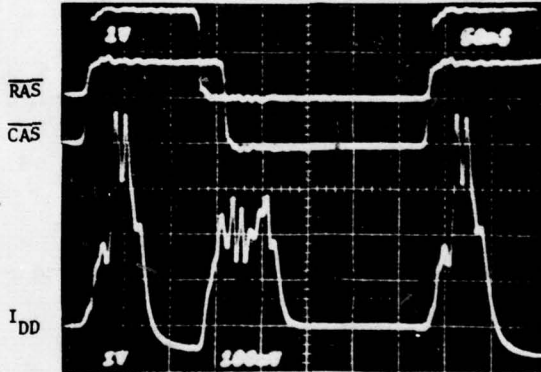

110 °C JUNCTION



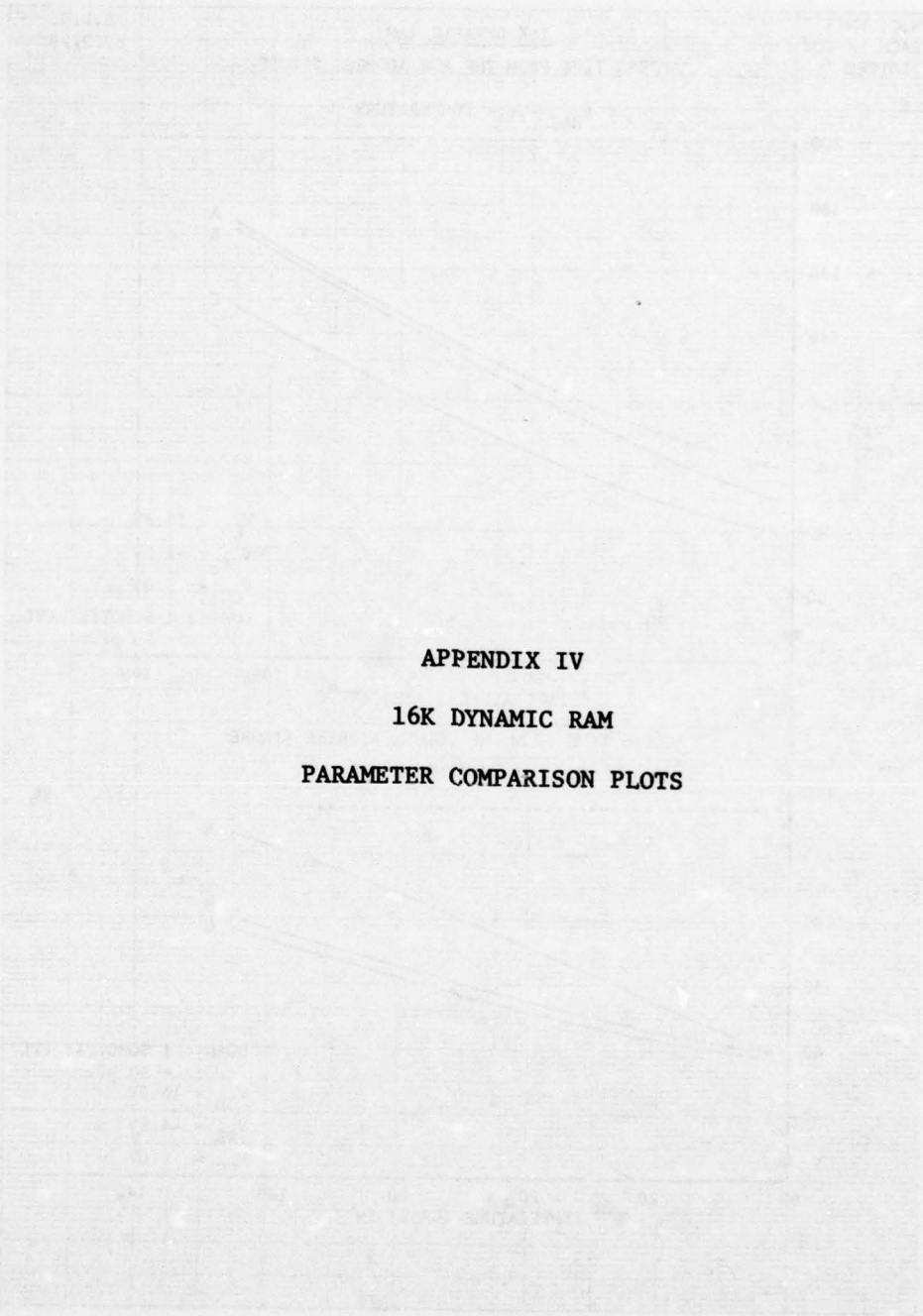

APPENDIX IV

16K DYNAMIC RAM

PARAMETER COMPARISON PLOTS

DIEZEL CORPORATION
 MADE IN U.S.A.

DIEZEL CORPORATION
 20 X 20 PER INCH

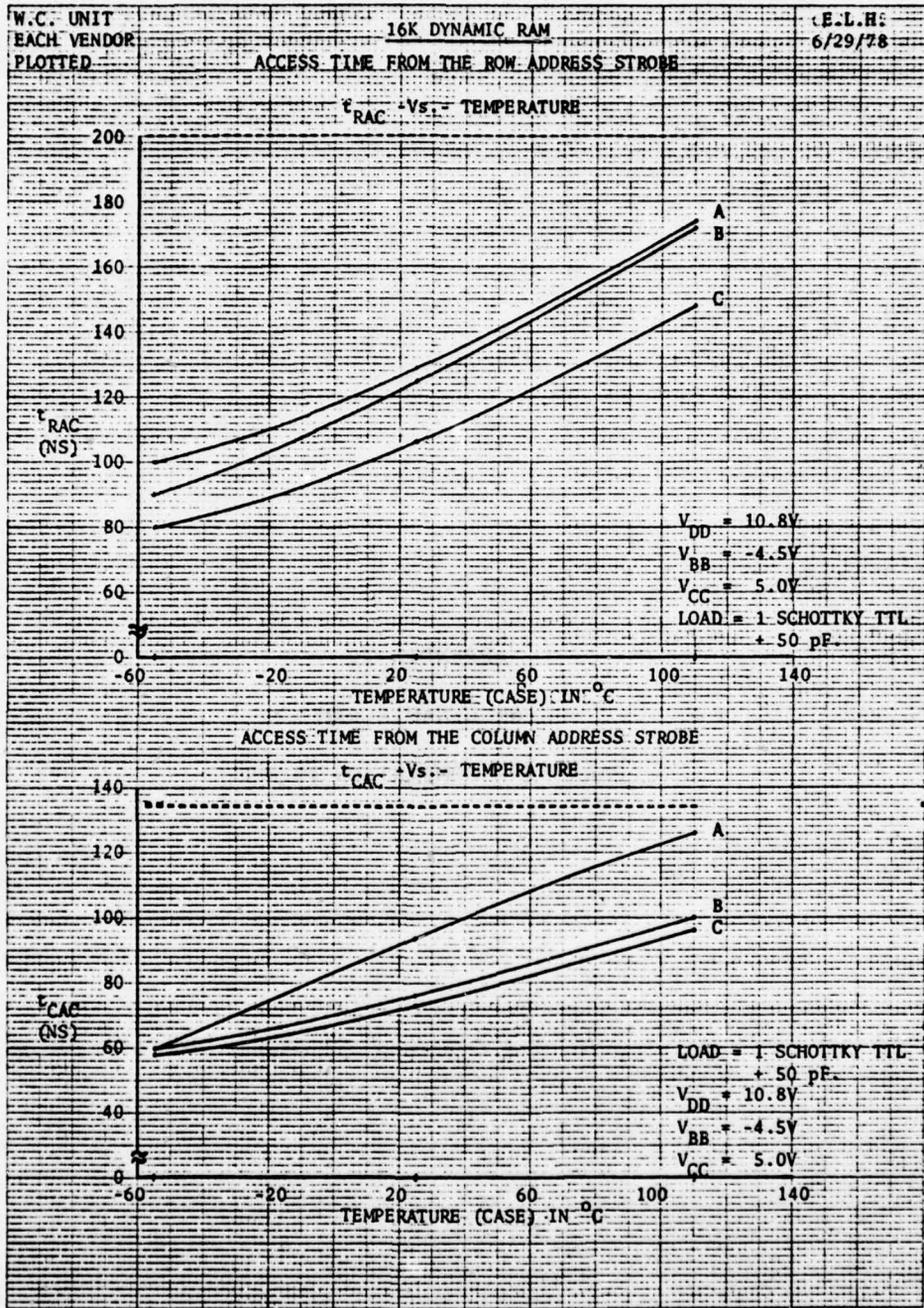

W.C. UNIT
EACH VENDOR
PLOTTED

E.L.H.
6/29/78

16K DYNAMIC RAM
ROW ADDRESS STROBE PRECHARGE TIME

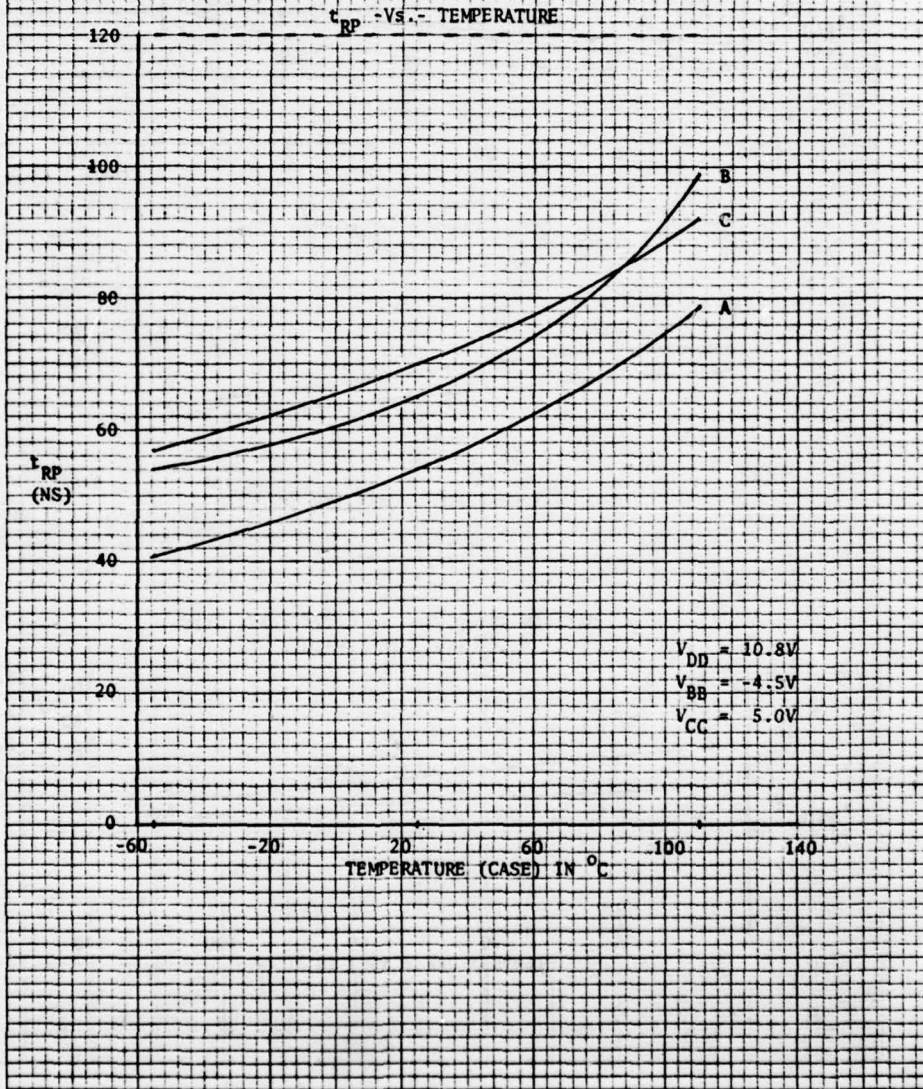

DIETZGEN CORPORATION
MADE IN U.S.A.

NO. 3411 111 DIETZGEN (SAMS) PART 117
10 X 10 PER INCH

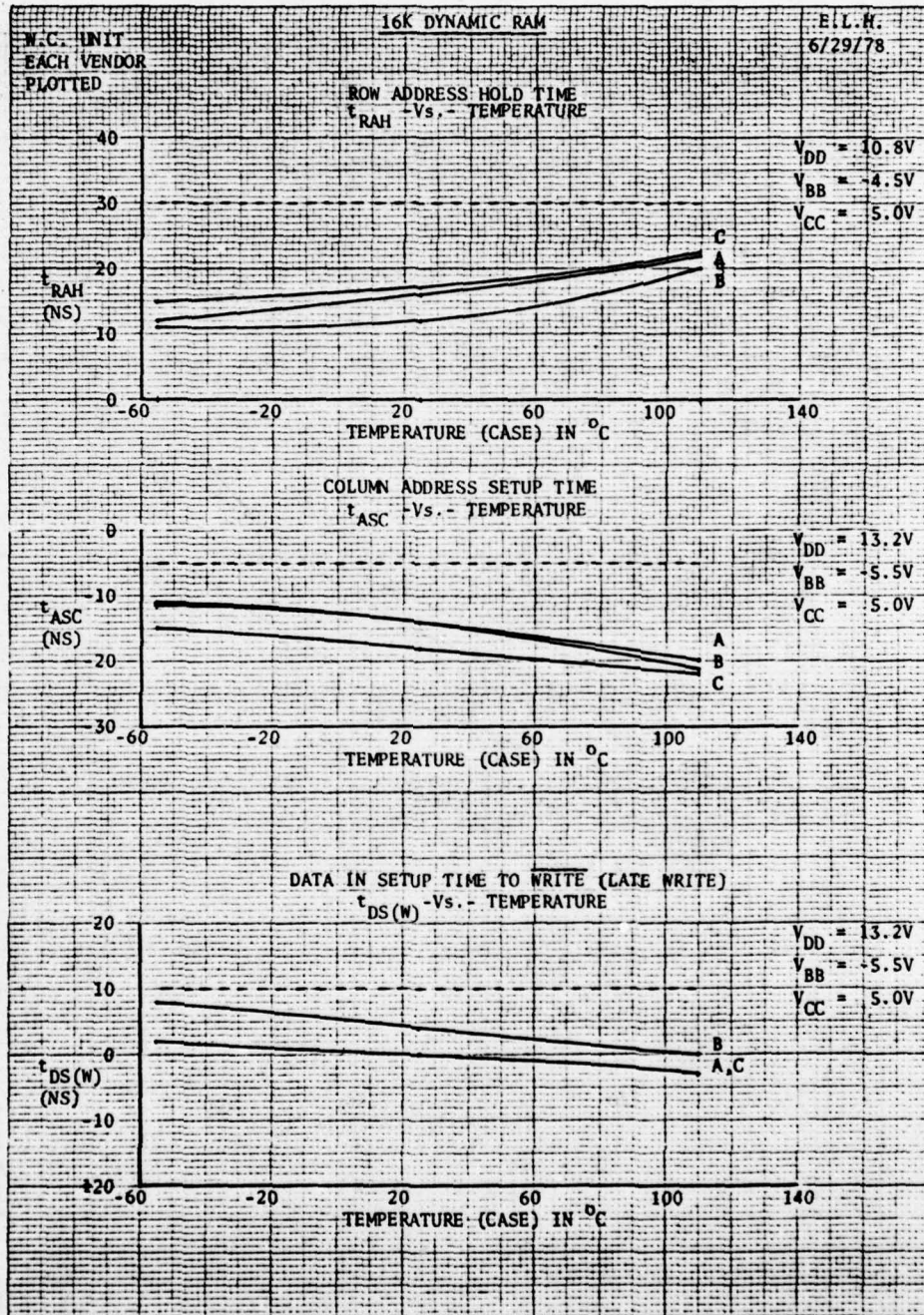

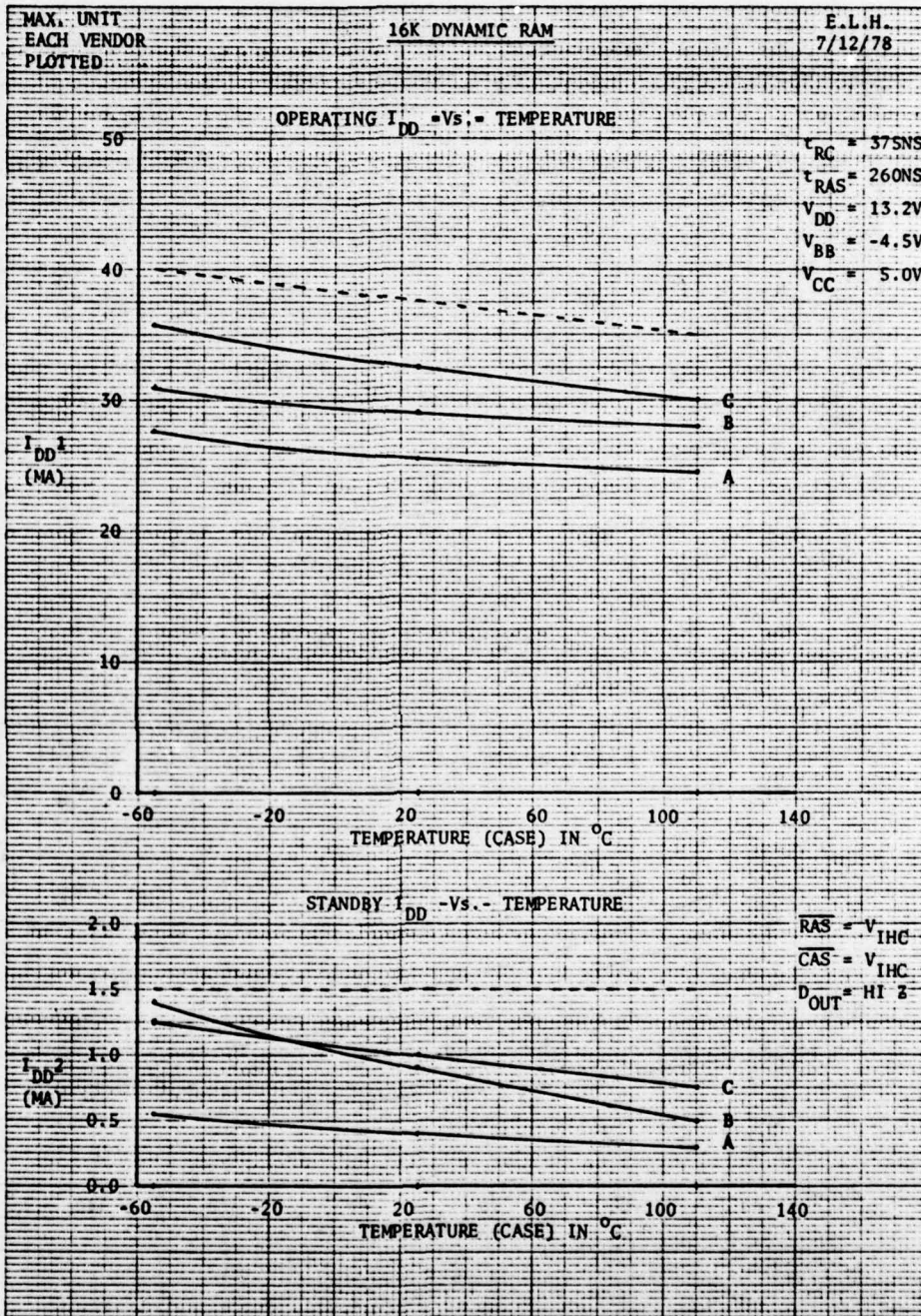

DIETZ AND ASSOCIATION
 4000 14th St. N.E.

HD-301-200 DIEZGEN GRAPH PAPER
 20 X 20 PER INCH

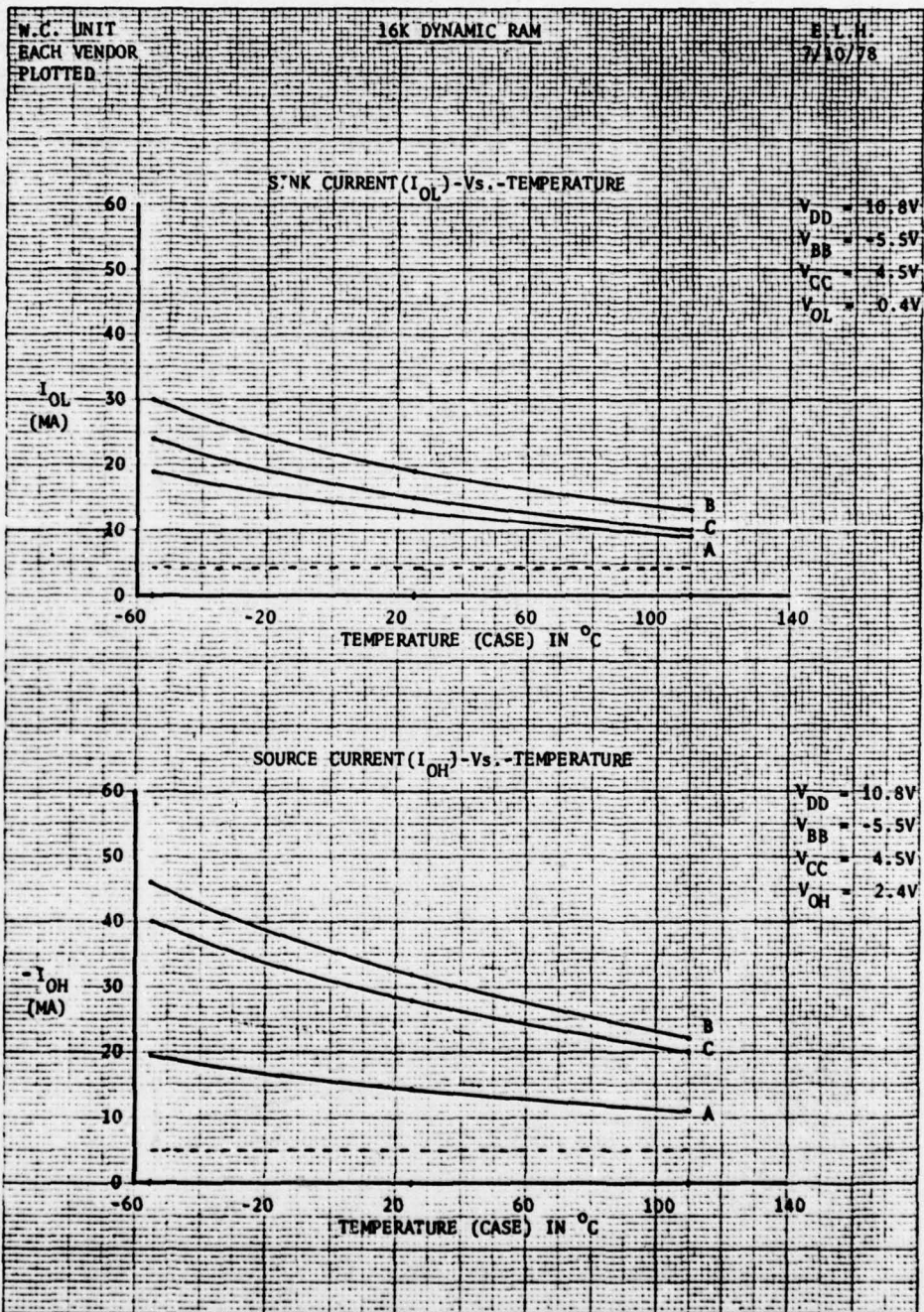

16K DYNAMIC RAM

DEVICE CAPACITANCE

Device input and output capacitance measurements were made using a BOONTON Model 75B-S8 capacitance bridge. This bridge uses a test frequency of 1.0 MHz. The test signal amplitude was set at 20 MV P-P.

Measurements were made with nominal voltages applied, and taken under biased conditions. Increasing bias from 0.0V to 2.4V or 2.7V in the case of the clock inputs, increases capacitance by 1.0 to 1.5 pF. The WORSE CASE reading for each input and the data output pin are recorded below.

| | | VENDOR | | |
|--------|----------------------|----------|--------|--------|
| | | A | B | C |
| PIN 2 | $\overline{D_{IN}}$ | = 2.1 pF | 1.9 pF | 2.3 pF |
| PIN 3 | \overline{WRITE} | = 3.5 pF | 2.4 pF | 3.1 pF |
| PIN 4 | \overline{RAS} | = 4.0 pF | 3.4 pF | 3.8 pF |
| PIN 5 | A_0 | = 2.0 pF | 2.1 pF | 1.8 pF |
| PIN 6 | A_2 | = 1.8 pF | 2.1 pF | 1.5 pF |
| PIN 7 | A_1 | = 1.9 pF | 1.9 pF | 1.6 pF |
| PIN 10 | A_5 | = 2.0 pF | 2.3 pF | 1.9 pF |
| PIN 11 | A_4 | = 1.9 pF | 2.0 pF | 1.5 pF |
| PIN 12 | A_3 | = 2.1 pF | 2.1 pF | 1.8 pF |
| PIN 13 | A_6 | = 2.2 pF | 2.7 pF | 1.8 pF |
| PIN 14 | $\overline{D_{OUT}}$ | = 2.8 pF | 2.7 pF | 2.8 pF |
| PIN 15 | \overline{CAS} | = 4.3 pF | 5.0 pF | 5.4 pF |

16K DYNAMIC RAM REV. G DATE CODE 7751
A.C. CHARACTERIZATION DATA OVERVIEW

| PARAMETER | SYMBOL | -55°C | | 25°C | | 110°C | | UNITS | RADC PROP.LIM. | P.S. Cond. |
|---|--------------------|---|------|------|------|-------|------|-------|-------------------|---------------|
| | | TYP. | W.C. | TYP. | W.C. | TYP. | W.C. | | | |
| Random Read or Write Cycle Time | t _{RC} | IN ORDER TO SET CHIP TEMPERATURE LIMITS, A MINIMUM CYCLE TIME, AS SPECIFIED IN PROPOSED LIMITS WAS USED | | | | | | NS | 375Min | |
| Read-Write Cycle Time | t _{RWC} | IN ORDER TO SET CHIP TEMPERATURE LIMITS, A MINIMUM CYCLE TIME, AS SPECIFIED IN PROPOSED LIMITS WAS USED | | | | | | NS | 375Min | |
| Page Mode Cycle Time | t _{PC} | IN ORDER TO SET CHIP TEMPERATURE LIMITS, A MINIMUM CYCLE TIME, AS SPECIFIED IN PROPOSED LIMITS WAS USED | | | | | | NS | 225Min | |
| Access Time from $\overline{\text{RAS}}$ | t _{RAC} | 96 | 100 | 114 | 129 | 155 | 174 | NS | 200Max | 1 |
| Access Time from $\overline{\text{CAS}}$ | t _{CAC} | 54 | 60 | 71 | 94 | 97 | 126 | NS | 135Max | 1 |
| Output buffer turn-off delay | t _{OFF} | 21 | 22 | 25 | 25 | 28 | 30 | NS | 50Max | 2 |
| Output buffer turn-off delay | t _{OFF} | 21 | 16 | 25 | 21 | 28 | 25 | NS | 0Min | 1 |
| $\overline{\text{RAS}}$ precharge time | t _{RP} | 30 | 41 | 42 | 56 | 55 | 79 | NS | 120Min | 1 |
| $\overline{\text{RAS}}$ pulse width | t _{RAS} | 76 | 87 | 100 | 112 | 132 | 150 | NS | 200Min | 1 |
| $\overline{\text{RAS}}$ pulse width | t _{RAS} | PASSED SCREEN AT 10.0 US | | | | | | US | 10Max | |
| $\overline{\text{RAS}}$ hold time | t _{RSH} | 48 | 56 | 61 | 70 | 78 | 92 | NS | 135Min | 1 |
| $\overline{\text{CAS}}$ hold time | t _{CSH} | 118 | 125 | 135 | 143 | 156 | 172 | NS | 200Min | |
| $\overline{\text{CAS}}$ pulse width | t _{CAS} | 53 | 60 | 70 | 78 | 91 | 107 | NS | 135Min | 1 |
| $\overline{\text{CAS}}$ pulse width | t _{CAS} | PASSED SCREEN AT 10.0 US | | | | | | US | 10Max | |
| $\overline{\text{RAS}}$ to $\overline{\text{CAS}}$ delay time | t _{RCD} | 10.5 | 12 | 14 | 16 | 16.5 | 22 | NS | 25Min | |
| $\overline{\text{RAS}}$ to $\overline{\text{CAS}}$ delay time | t _{RCD} | - | 132 | - | 106 | - | 74 | NS | 65Max | |
| $\overline{\text{CAS}}$ to $\overline{\text{RAS}}$ precharge time | t _{CRP} | ≤ -50 over temp. range | | | | | | NS | -20Min | |
| Row address set-up time | t _{ASR} | -6 | -2 | -9 | -6 | -10 | -9.5 | NS | 0Min | 2 |
| Row Address hold time | t _{RAH} | 10.5 | 12 | 14 | 16 | 16.5 | 22 | NS | 25Min | 1 |
| Column Address set-up time | t _{ASC} | -14 | -11 | -18 | -14 | -25 | -20 | NS | -10Min | 2 |
| Column Address hold time | t _{CAH} | - | 30 | - | - | - | 40 | NS | 55Min | 1 |
| Column Address hold time referenced to $\overline{\text{RAS}}$ | t _{AR} | - | 95 | - | - | - | 105 | NS | 120Min | 1 |
| Read command set-up time | t _{RCS} | -22 | -19 | -29 | -25 | -39 | -33 | NS | 0Min | 2 |
| Read command hold time | t _{RCH} | PASSED a-1NS Screen over Temperature | | | | | | NS | 0Min | |
| Write command hold time | t _{WCH} | 24 | 28 | 32 | 38 | 42 | 52 | NS | 55Min | 1 |
| Write command hold time referenced to $\overline{\text{RAS}}$ | t _{WCR} | 52 | 61 | 70 | 79 | 90 | 104 | NS | 120Min | 1 |
| Write command pulse width | t _{WP} | 11 | 12 | 16 | 19 | 19 | 25 | NS | 55Min | 1 |
| Write command to $\overline{\text{RAS}}$ lead time | t _{RWL} | 13 | 19 | 18 | 25 | 24 | 35 | NS | 80Min | 1 |
| Write command to $\overline{\text{CAS}}$ lead time | t _{CWL} | 13 | 16 | 18 | 24 | 25 | 36 | NS | 80Min | 1 |
| Data-in set-up time to $\overline{\text{CAS}}$ | t _{DS(C)} | -10 | -7 | -16 | -12 | -24 | -19 | NS | 0Min | 2 |
| Data-in set-up time to $\overline{\text{WRITE}}$ | t _{DS(W)} | +1 | +2 | -2 | 0 | -5 | -3 | NS | 10Min | 1 |
| Data-in hold time to $\overline{\text{CAS}}$ | t _{DH(C)} | 17 | 21 | 23 | 27 | 31 | 36 | NS | 60 Min | 1 |
| Data-in hold time to $\overline{\text{WRITE}}$ | t _{DH(W)} | 9 | 11 | 11 | 14 | 14 | 18 | NS | 60 Min | 1 |
| Data-in hold time referenced to $\overline{\text{RAS}}$ | t _{DHR} | 51 | 57 | 63 | 72 | 84 | 101 | NS | 125 Min | 1 |
| $\overline{\text{CAS}}$ precharge time (Page-mode only) | t _{CP} | - | 20 | - | - | - | 30 | NS | 80Min | |
| Refresh period | t _{REF} | RANGE of 2.15 to 7.3 @ 110°C (CASE) | | | | | | MS | 1.0Max | 3 |
| WRITE command set-up time | t _{WCS} | -41 | -36 | -51 | -46 | -62 | -56 | NS | -20Min | 2 |
| $\overline{\text{CAS}}$ to $\overline{\text{WRITE}}$ delay | t _{CWD} | 42 | 48 | 52 | 58 | 64 | 73 | NS | 95Min | 1 |
| $\overline{\text{RAS}}$ to $\overline{\text{WRITE}}$ delay | t _{RWD} | 70 | 79 | 92 | 101 | 120 | 131 | NS | 160Min | 3 |

Temperatures are CASE

TYP.=All Voltages NOMINAL

W.C.=Voltages Worse Case by $\pm 10\%$

P.S. Cond. 1= $V_{DD}=10.8V, V_{BB}=-4.5V, V_{CC}=5.0V$

P.S. Cond. 2= $V_{DD}=13.2V, V_{BB}=-5.5V, V_{CC}=5.0V$

P.S. Cond. 3= $V_{DD}=10.8V, V_{BB}=-5.5V, V_{CC}=5.0V$

Above data taken with transition times (t_T Rise and Fall) of 3-5NS

Input Levels: $V_{ihc}=2.7v, V_{ih}=2.4v, V_{il}=0.8v$
measurement points were 1.5v to 1.5v levels

16K DYNAMIC RAM REV. G DATE CODE 7751

D.C. CHARACTERIZATION DATA OVERVIEW

| PARAMETER | SYMBOL | -55°C | | 25°C | | 110°C | | UNITS | RADC PROP. LIM. | P.S. COND. | NOTES |
|---------------------------|------------|---|------|------|------|-------|------|---------|-----------------|------------|-------|
| | | TYP. | W.C. | TYP. | W.C. | TYP. | W.C. | | | | |
| OPERATING CURRENT | I_{DD} 1 | 23.3 | 27.4 | 22.0 | 25.5 | 21.0 | 24.4 | MA | 40Max | 2 | 1 |
| RAS, CAS CYCLING | I_{CC} 1 | - | 149 | - | 151 | - | 154 | μ A | 600Max | 1 | 2 |
| $t_{RC}=375NS$ | I_{BB} 1 | 98 | 249 | 49 | 120 | 29 | 73 | μ A | 400Max | 2 | |
| STANDBY CURRENT | I_{DD} 2 | 0.47 | 0.54 | 0.33 | 0.39 | 0.23 | 0.29 | μ A | 1.5Max | 2 | |
| RAS, CAS= V_{IHC} | I_{CC} 2 | - | - | - | - | - | - | μ A | 10Max | | |
| D_{OUT} -HIGH IMPEDANCE | I_{BB} 2 | 0.8 | 1.5 | 0.5 | 0.5 | 1.0 | 1.0 | μ A | 100Max | 2 | |
| REFRESH CURRENT | I_{DD} 3 | 15.3 | 15.8 | 14.3 | 14.7 | 13.6 | 14.0 | μ A | 27Max | 2 | 1 |
| RAS CYCLING | I_{CC} 3 | - | - | - | - | - | - | μ A | 10Max | | |
| $t_{RC}=375NS$ | I_{BB} 3 | SEE I_{BB} 1 | | | | | | μ A | 400Max | 2 | |
| PAGE MODE CURRENT | I_{DD} 4 | PAGE MODE NOT TESTED | | | | | | MA | 27Max | 2 | 1 |
| RAS= V_{IL} | I_{CC} 4 | PROPOSED LIMITS GUARANTEED | | | | | | μ A | 1000Max | 1 | 2 |
| CAS CYCLING | I_{BB} 4 | | | | | | | μ A | 400Max | 2 | |
| $t_{PC}=225NS$ | | | | | | | | | | | |
| INPUT HIGH VOLTAGE | V_{IHC} | - | - | - | - | - | - | V | 7.0Max | | |
| RAS, CAS, WRITE | | 1.84 | 1.82 | 1.66 | 1.76 | 1.56 | 1.65 | V | 2.7Min | 4 | |
| INPUT HIGH VOLTAGE | V_{IH} | - | - | - | - | - | - | V | 7.0Max | | |
| A0-A6, D_{IN} | | 1.82 | 2.0 | 1.72 | 1.9 | 1.62 | 1.8 | V | 2.4Min | 4 | |
| INPUT LOW VOLTAGE | V_{IL} | - | - | - | - | - | - | V | -1.0Min | | |
| ALL INPUTS | | 1.52 | 1.42 | 1.38 | 1.28 | 1.24 | 1.1 | V | 0.8Max | 5 | |
| INPUT LEAKAGE | $I_{I(L)}$ | NO DISCERNIBLE LEAKAGE WAS MEASURABLE ON TEKTRONIX TYPE | | | | | | μ A | -10Min | | |
| OUTPUT LEAKAGE | $I_{O(L)}$ | 576 CURVE TRACER (10 NANOAMP RANGE) | | | | | | μ A | +10Max | | |
| | | | | | | | | μ A | -10Min | | |
| | | | | | | | | μ A | +10Max | | |
| OUTPUT HIGH VOLTAGE | V_{OH} | 3.5 | 3.4 | 3.7 | 3.6 | 4.0 | 3.9 | V | 2.4Min | 3 | |
| $I_{OUT}=-5.0MA$ | | | | | | | | | | | |
| OUTPUT LOW VOLTAGE | V_{OL} | - | 0.09 | - | 0.13 | - | 0.19 | V | 0.4Max | 3 | |
| $I_{OUT}=4.2MA$ | | | | | | | | | | | |
| INPUT CAPACITANCE | C_{11} | - | - | - | 2.2 | - | - | pFd | 5Max | NOMINAL | 3 |
| A0-A6, D_{IN} | | | | | | | | | | | |
| INPUT CAPACITANCE | C_{12} | - | - | - | 4.3 | - | - | pFc | 10Max | NOMINAL | 3 |
| RAS, CAS, WRITE | | | | | | | | | | | |
| OUTPUT CAPACITANCE | C_0 | - | - | - | 2.8 | - | - | pFd | 7Max | NOMINAL | 3 |

TEMPERATURES ARE CASE
 TYP.=ALL VOLTAGES NOMINAL
 W.C.=VOLTAGES WORSE CASE (SEE P.S. COND.)

P.S. COND. 1 $V_{DD}=10.8V, V_{BB}=-4.5V, V_{CC}=5.5V$
 2 $V_{DD}=13.2V, V_{BB}=-4.5V, V_{CC}=5.0V$
 3 $V_{DD}=10.8V, V_{BB}=-5.5V, V_{CC}=4.5V$
 4 $V_{DD}=13.2V, V_{BB}=-5.5V, V_{CC}=5.0V$
 5 $V_{DD}=10.8V, V_{BB}=-4.5V, V_{CC}=5.0V$

NOTES: 1) DEPENDS ON CYCLE RATE
 2) DEPENDS ON OUTPUT LOAD. (ONE SCHOTTKY TTL + 50pFd) ALTERNATING "1", "0" PATTERN IS WORSE CASE.
 3) MEASUREMENTS MADE USING A BOONTON MOD 75B-S8 CAPACITANCE BRIDGE, 1.0MHZ, 20MV P-P.

16K DYNAMIC RAM - Timing

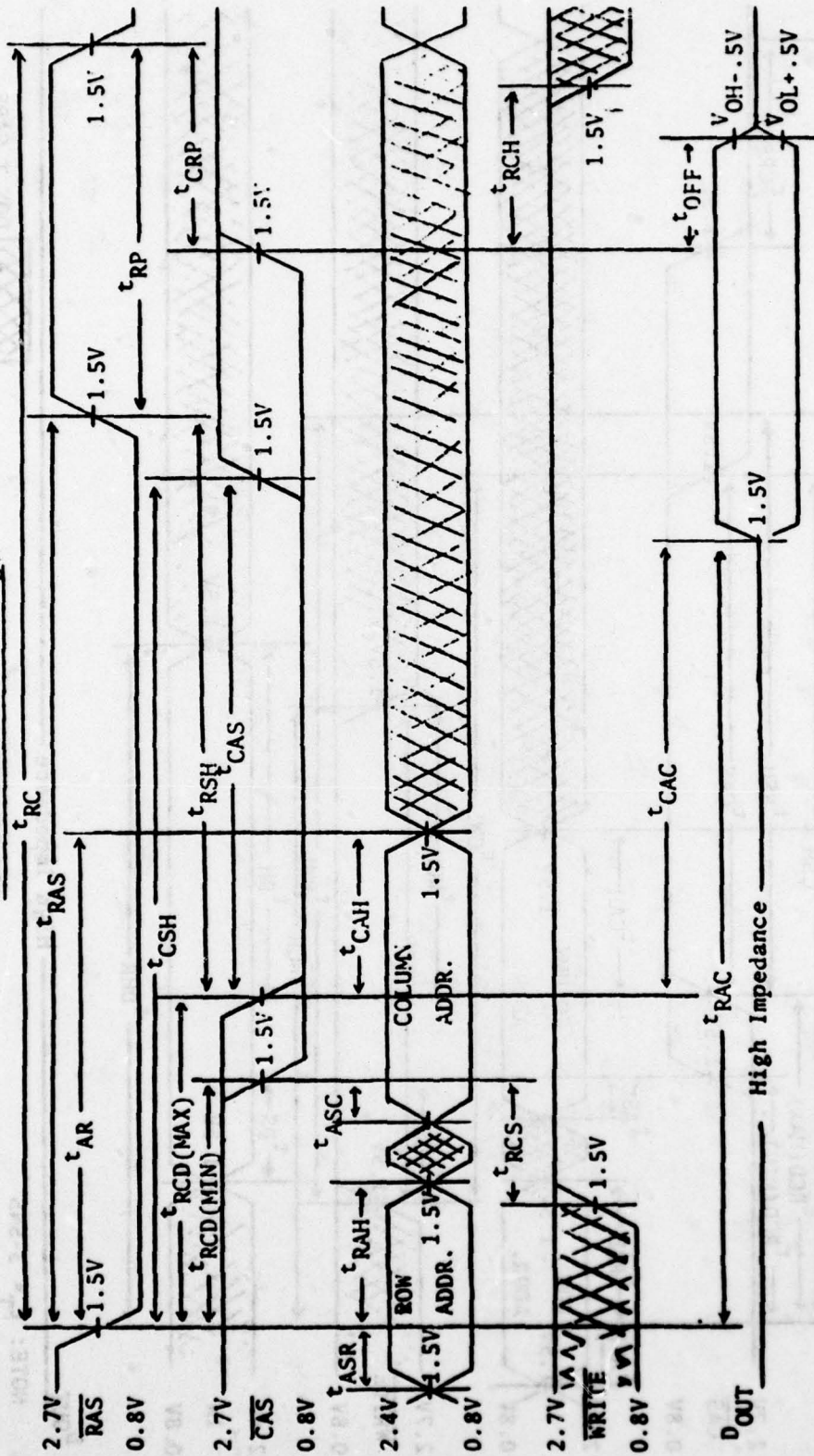

NOTE: $t_T = 3-5NS$



READ CYCLE

16K DYNAMIC RAM - Timing

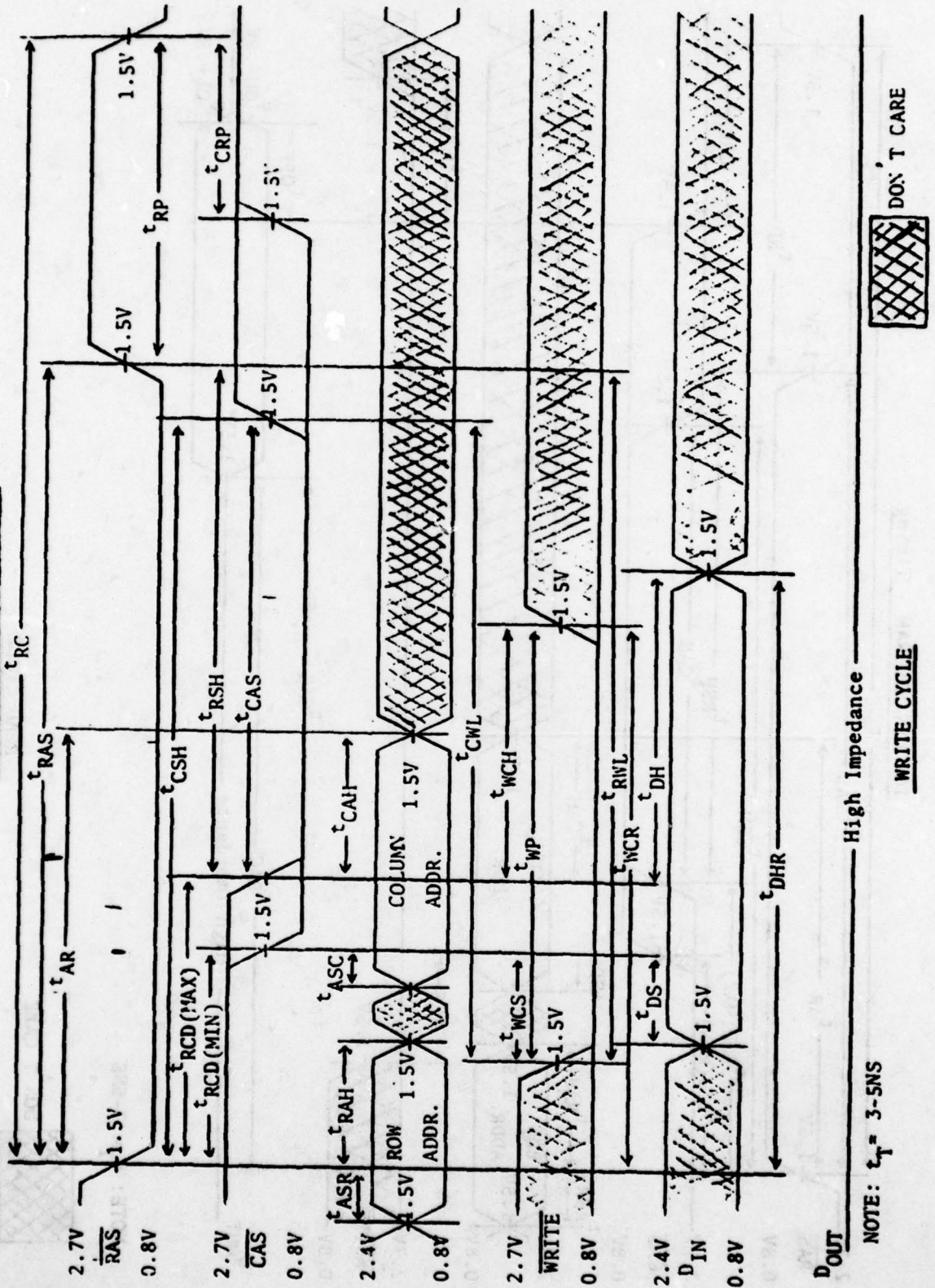

NOTE: $t_T = 3-5NS$

High Impedance

WRITE CYCLE

APPENDIX VI

16K DYNAMIC RAM

This section describes a characterization test for the 16K dynamic RAM. It includes a detailed description of the test algorithm and the test results. It is intended for use in the following manner:

APPENDIX VI

16K DYNAMIC RAM

TEST ALGORITHMS

NOTE: The tests described here-in were used for characterization only and in no way reflect what should or should not be used for production testing.

16K DYNAMIC RAM

Pattern 1 - Address Complement, Data Background = Y-BAR

This pattern produces a checkerboard and its complement in an inter-digitated array. It produces maximum address line noise and checks the decoder dynamic response times. It is performed in the following manner.

- Step 1 - Perform 8 pump cycles
- Step 2 - Load memory with background data
- Step 3 - Read entire memory (DATA Verification)
- Step 4 - Read minimum address location
- Step 5 - Read maximum address location
- Step 6 - Read location min. +1
- Step 7 - Read location max. -1
- Step 8 - Continue incrementing and decrementing from min. and max. locations until all locations have been read
- Step 9 - Repeat steps 2 through 8 with complement data

Test Time = $3N \times \text{cycle time} + 8 \text{ cycles}$

Pattern 2 - Shifting Diagonal, Initial Data Background = Major Diagonal

This pattern is a good test for sense line imbalance and response plus restore noise in addition to multiple selection. It is performed in the following manner.

- Step 1 - Perform 8 pump cycles
- Step 2 - Load memory with data background, scan from minimum location to maximum location
- Step 3 - Read data in the memory, scan from maximum location to minimum location
- Step 4 - Repeat steps 2 and 3, each time shifting the diagonal by one until it has occupied every position in the memory (128 Load/Read scans)
- Step 5 - Repeat steps 2 through 4 with complement data

Test Time = $256N \times \text{cycle time} + 8 \text{ cycles}$

Pattern 3 - March Data, Data Background = All "0"

This pattern tests for address uniqueness and multiple selection. It is performed in the following manner.

- Step 1 - Perform 8 pump cycles
- Step 2 - Load memory with background data
- Step 3 - Read location 0
- Step 4 - Write data complement in location 0
- Step 5 - Read data complement in location 0
- Step 6 - Repeat steps 3 through 5 for all other locations in the memory (sequentially)
- Step 7 - Read data complement at MAX. location
- Step 8 - Write data at MAX. location
- Step 9 - Read data at MAX. location
- Step 10 - Repeat steps 7 through 9 for all other locations in the memory (decrementing from MAX. location to MIN. location)
- Step 11 - Repeat steps 3 through 10 with data background of all "1"

Test Time = $14N \times \text{cycle time} + 8 \text{ pump cycles}$

Pattern 4 - Static Refresh (Periphery Retention)

This pattern tests for periphery retention time by attempting to write after a lengthy pause. This test is performed at 110°C (CASE) only and is not used to measure the retention time of the periphery circuits but to ensure that they will hold for at least 5 MS. It is performed in the following manner.

- Step 1 - Perform 8 pump cycles
- Step 2 - Load memory with all "0"s
- Step 3 - Read memory, all "0"s
- Step 4 - Pause (stop all clocks) 5 MS
- Step 5 - Load memory with all "1"s
- Step 6 - Read memory, all "1"s
- Step 7 - Pause (stop all clocks) 5 MS
- Step 8 - Load memory with all "0"s
- Step 9 - Read memory, all "0"s

Test Time = $6N \times \text{cycle time} + 8 \text{ cycles} + 10 \text{ MS}$

Pattern 5 - Refresh Test (Cell Retention)

This test is used to check the retention time of the memory cells under dynamic conditions. It is done at high temperatures only and is performed in the following manner.

- Step 1 - Perform 8 pump cycles
- Step 2 - Load memory with DATA as shown below
- Step 3 - Read entire memory (DATA verification)
- Step 4 - Alternate reading between LOC. 63 and LOC. 64*
- Step 5 - Read entire memory
- Step 6 - Load memory with DATA
- Step 7 - Repeat steps 3 through 5

* Refresh (t_{REF}) = # reads x cycle time

LOC.0

| |
|----------------------|
| 11111111111111111111 |
| 00000000000000000000 |
| 0 8 K ARRAY 0 |
| 0 (DATA) 0 |
| 0 0 |
| 00000000000000000000 |

| |
|----------------------|
| 00000000000000000000 |
| 11111111111111111111 |
| 1 8 K ARRAY 1 |
| 1 (DATA) 1 |
| 1 1 |
| 11111111111111111111 |

LOC.16,383

NOTE: DATA is not complemented on A_6

Pattern 6 - Extended Cycle Test (10 μ s), Data Background = X-BAR

This test is used to verify the 10 μ s max limit on \overline{RAS} and \overline{CAS} pulse width. Front and back edge timing is held to normal cycle timing while the cycle is increased to allow 10 μ s of RAS and CAS active time (low level). It is performed in the following manner.

- Step 1 - Perform 8 pump cycles
- Step 2 - Write data in location 0
- Step 3 - Read data in location 0
- Step 4 - Repeat steps 2 and 3 for all other locations in the memory (sequentially)
- Step 5 - Repeat steps 2 through 4 with complement data.

Test Time = 4N x cycle time + 8 pump cycles

Pattern 7 - Continuous Read, Data Background = X-BAR

This pattern is used to allow the maximum amount of current (I_{CC}) to be drawn from the V_{CC} power supply. It is performed in the following manner with normal cycle timing. It also applies to I_{DD} and I_{BB} currents.

- Step 1 - Perform 8 pump cycles
- Step 2 - Load memory with background data
- Step 3 - Sequentially read entire memory
- Step 4 - Repeat step 3 as many times as necessary to achieve a stabilized current reading

Test Time - Undefined

MISSION
of
Rome Air Development Center

RADC plans and conducts research, exploratory and advanced development programs in command, control, and communications (C³) activities, and in the C³ areas of information sciences and intelligence. The principal technical mission areas are communications, electromagnetic guidance and control, surveillance of ground and aerospace objects, intelligence data collection and handling, information system technology, ionospheric propagation, solid state sciences, microwave physics and electronic reliability, maintainability and compatibility.

