

AD-A067 981

MINISTRY OF DEFENCE LONDON (ENGLAND)
HELICOPTER ICING SYMPOSIUM, 6-7 NOVEMBER 1978, LONDON, (U)
NOV 78 T C DON

F/6 1/3

UNCLASSIFIED

NL

1 of 4
AD
A067981

The microfiche card displays a grid of 144 frames. The content is as follows:

- Row 1: Frame 1 (top-left) contains the text '1 of 4' and 'AD A067981'. Frame 12 (top-right) contains the text 'NL'.
- Row 2: Frames 1-12 contain various text blocks.
- Row 3: Frames 1-12 contain various text blocks.
- Row 4: Frames 1-12 contain various text blocks.
- Row 5: Frames 1-12 contain various text blocks.
- Row 6: Frames 1-12 contain various text blocks.
- Row 7: Frames 1-12 contain various text blocks.
- Row 8: Frames 1-12 contain various text blocks.
- Row 9: Frames 1-12 contain various text blocks.
- Row 10: Frames 1-12 contain various text blocks.
- Row 11: Frames 1-12 contain various text blocks.
- Row 12: Frames 1-12 contain various text blocks.

DDC FILE COPY

ADA067981

Author's Reply. I have no experience of the backscatter device.

Dr P Ryder, UK. We have a forward scatter, rather than backscatter device and a
testament as our research aircraft (C130). We have found extremely

SECURITY CLASSIFICATION OF THIS PAGE (When Data Entered)

| REPORT DOCUMENTATION PAGE | | READ INSTRUCTIONS BEFORE COMPLETING FORM |
|--|--|--|
| 1. REPORT NUMBER | 2. GOVT ACCESSION NO. | 3. RECIPIENT'S CATALOG NUMBER |
| 6. TITLE (and Subtitle) Helicopter Icing Symposium, 6-7 November 1978, London, | | 5. TYPE OF REPORT & PERIOD COVERED |
| 7. AUTHOR(s) | | 6. PERFORMING ORG. REPORT NUMBER |
| 10. T. C. Don (Editor) | | 8. CONTRACT OR GRANT NUMBER(s) |
| 9. PERFORMING ORGANIZATION NAME AND ADDRESS Ministry of Defense (Procurement Executive) ATTN: T. C. Don, Room 808 St. Giles Court, 1-13 St. Giles High Street London, England WC2H 8LD | | 10. PROGRAM ELEMENT, PROJECT, TASK AREA & WORK UNIT NUMBERS |
| 11. CONTROLLING OFFICE NAME AND ADDRESS NATO Army Armaments Group Panel X, Helicopter Icing Subgroup | | 12. REPORT DATE November 1978 |
| 14. MONITORING AGENCY NAME & ADDRESS (if different from Controlling Office) Applied Technology Laboratory, US Army Research & Technology Laboratories (AVRADCOM) Fort Eustis, Virginia 23604 | | 13. NUMBER OF PAGES |
| | | 15. SECURITY CLASS. (of this report) Unclassified |
| 16. DISTRIBUTION STATEMENT (of this Report) Approved for public release; distribution unlimited. | | 15a. DECLASSIFICATION/DOWNGRADING SCHEDULE |
| 17. DISTRIBUTION STATEMENT (of the abstract entered in Block 20, if different from Report) | | |
| 18. SUPPLEMENTARY NOTES | | |
| 19. KEY WORDS (Continue on reverse side if necessary and identify by block number) | | |
| Ice Protection Meteorological data Design Criteria | Deicing systems Flight testing Ice prevention Instrumentation | Meteorology Snow Rotary wing aircraft |
| 20. ABSTRACT (Continue on reverse side if necessary and identify by block number) This document is a collection of papers presented at the Helicopter Icing Symposium, held in London, England, 6-7 November 1978. The emphasis of the symposium was on helicopter rotor blade icing. Papers covered methods of rotor blade ice protection (electrothermal, ice phobic coatings, microwave, vibratory and mechanical-pneumatic concepts); design and test criteria; ice protection system capabilities; and testing and certification methods. Also included are papers on meteorological data; instrumentation; icing tunnel tests and correlations of results to mathematical accretion model; and simulated and natural icing flight tests. | | |

INSTRUCTIONS FOR PREPARATION OF REPORT DOCUMENTATION PAGE

RESPONSIBILITY. The controlling DoD office will be responsible for completion of the Report Documentation Page, DD Form 1473, in all technical reports prepared by or for DoD organizations.

CLASSIFICATION. Since this Report Documentation Page, DD Form 1473, is used in preparing announcements, bibliographies, and data banks, it should be unclassified if possible. If a classification is required, identify the classified items on the page by the appropriate symbol.

COMPLETION GUIDE

General. Make Blocks 1, 4, 5, 6, 7, 11, 13, 15, and 16 agree with the corresponding information on the report cover. Leave Blocks 2 and 3 blank.

Block 1. Report Number. Enter the unique alphanumeric report number shown on the cover.

Block 2. Government Accession No. Leave blank. This space is for use by the Defense Documentation Center.

Block 3. Recipient's Catalog Number. Leave blank. This space is for the use of the report recipient to assist in future retrieval of the document.

Block 4. Title and Subtitle. Enter the title in all capital letters exactly as it appears on the publication. Titles should be unclassified whenever possible. Write out the English equivalent for Greek letters and mathematical symbols in the title (see "Abstracting Scientific and Technical Reports of Defense-sponsored RDT/E," AD-667 000). If the report has a subtitle, this subtitle should follow the main title, be separated by a comma or semicolon if appropriate, and be initially capitalized. If a publication has a title in a foreign language, translate the title into English and follow the English translation with the title in the original language. Make every effort to simplify the title before publication.

Block 5. Type of Report and Period Covered. Indicate here whether report is interim, final, etc., and, if applicable, inclusive dates of period covered, such as the life of a contract covered in a final contractor report.

Block 6. Performing Organization Report Number. Only numbers other than the official report number shown in Block 1, such as series numbers for in-house reports or a contractor/grantee number assigned by him, will be placed in this space. If no such numbers are used, leave this space blank.

Block 7. Author(s). Include corresponding information from the report cover. Give the name(s) of the author(s) in conventional order (for example, John R. Doe or, if author prefers, J. Robert Doe). In addition, list the affiliation of an author if it differs from that of the performing organization.

Block 8. Contract or Grant Number(s). For a contractor or grantee report, enter the complete contract or grant number(s) under which the work reported was accomplished. Leave blank in in-house reports.

Block 9. Performing Organization Name and Address. For in-house reports enter the name and address, including office symbol, of the performing activity. For contractor or grantee reports enter the name and address of the contractor or grantee who prepared the report and identify the appropriate corporate division, school, laboratory, etc., of the author. List city, state, and ZIP Code.

Block 10. Program Element, Project, Task Area, and Work Unit Numbers. Enter here the number code from the applicable Department of Defense form, such as the DD Form 1498, "Research and Technology Work Unit Summary" or the DD Form 1634, "Research and Development Planning Summary," which identifies the program element, project, task area, and work unit or equivalent under which the work was authorized.

Block 11. Controlling Office Name and Address. Enter the full, official name and address, including office symbol, of the controlling office. (Equates to funding/sponsoring agency. For definition see DoD Directive 5200.20, "Distribution Statements on Technical Documents.")

Block 12. Report Date. Enter here the day, month, and year or month and year as shown on the cover.

Block 13. Number of Pages. Enter the total number of pages.

Block 14. Monitoring Agency Name and Address (if different from Controlling Office). For use when the controlling or funding office does not directly administer a project, contract, or grant, but delegates the administrative responsibility to another organization.

Blocks 15 & 15a. Security Classification of the Report: Declassification/Downgrading Schedule of the Report. Enter in 15 the highest classification of the report. If appropriate, enter in 15a the declassification/downgrading schedule of the report, using the abbreviations for declassification/downgrading schedules listed in paragraph 4-207 of DoD 5200.1-R.

Block 16. Distribution Statement of the Report. Insert here the applicable distribution statement of the report from DoD Directive 5200.20, "Distribution Statements on Technical Documents."

Block 17. Distribution Statement (of the abstract entered in Block 20, if different from the distribution statement of the report). Insert here the applicable distribution statement of the abstract from DoD Directive 5200.20, "Distribution Statements on Technical Documents."

Block 18. Supplementary Notes. Enter information not included elsewhere but useful, such as: Prepared in cooperation with . . . Translation of (or by) . . . Presented at conference of . . . To be published in . . .

Block 19. Key Words. Select terms or short phrases that identify the principal subjects covered in the report, and are sufficiently specific and precise to be used as index entries for cataloging, conforming to standard terminology. The DoD "Thesaurus of Engineering and Scientific Terms" (TEST), AD-672 000, can be helpful.

Block 20: Abstract. The abstract should be a brief (not to exceed 200 words) factual summary of the most significant information contained in the report. If possible, the abstract of a classified report should be unclassified and the abstract to an unclassified report should consist of publicly-releasable information. If the report contains a significant bibliography or literature survey, mention it here. For information on preparing abstracts see "Abstracting Scientific and Technical Reports of Defense-Sponsored RDT&E," AD-667 000.

NATO
ARMY ARMAMENTS GROUP
PANEL X (INTER SERVICE GROUP) ON
AIR VEHICLES FOR TACTICAL AIR MOBILITY
HELICOPTER ICING SUB-GROUP

SYMPOSIUM ON
HELICOPTER ICING

This publication is a collection of the papers prepared for presentation at the above symposium. A record of discussions and overall conclusions from the symposium will be published for subsequent inclusion.

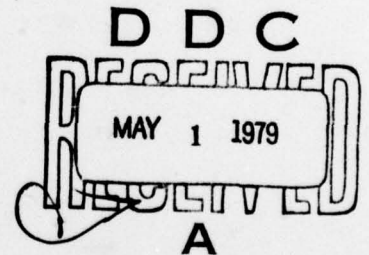

ORGANISED BY THE
DIRECTORATE OF HELICOPTER PROJECTS
MINISTRY OF DEFENCE (PE)

UK

| | |
|---------------------------------|---|
| ADMISSION for | |
| NTIS | White Section <input checked="" type="checkbox"/> |
| DDC | Buff Section <input type="checkbox"/> |
| UNANNOUNCED | <input type="checkbox"/> |
| JUSTIFICATION | |
| BY | |
| DISTRIBUTION/AVAILABILITY CODES | |
| Dist. | AVAIL. and/or SPECIAL |
| A | |

79 04 27 067

NAAG PANEL X

HELICOPTER ICING SUB GROUP COMPOSITION

CANADA
FRANCE
FRG
UK
USA

HOST NATION CO-ORDINATOR

MR T C DON
MOD(PE)
ROOM 808
ST GILES COURT
1-13 ST GILES HIGH STREET
LONDON WC2H 8LD

~~Requests for further copies of this booklet should be sent to the above address. Quote Ref D/Dir/9/1/10~~

(ii)



Procurement Executive, Ministry of Defence

H/G2

Room 808

St Giles Court 1 St Giles High Street London WC2H 8LD

Telex 22241

Telephone Direct line 01-632 - 7900
Switchboard 01-632 3333

(P)

Aug 7 987

Symposium Attendees

Your reference

Our reference

D/DHP/9/1/10

Date

23 March 1979

79-13

ADDITIONS TO BOOKLET SUPPLIED AT NATO PANEL X SYMPOSIUM ON HELICOPTER ICING

The attached sheets are transcripts of question and answer sessions and panel discussions held during the Helicopter Icing Symposium on 6-7 November 1978.

Transcripts from Sessions I, II and IV have author names indicated on their first pages, and should be inserted after the corresponding author's paper in the booklet. The Session III transcript should be inserted after the last paper in Session III, whilst the transcript for Session V should be inserted at the end of the booklet.

T.C. Don

T C DON

79 05 08 033

Discussion

S O'Keefe, USA. Are records available showing torque requirements with blades having clear ice against rime ice.

Authors Reply. Such records do exist from flight trials held by A&AEE and WHL, showing the torque loss with the different ice types. The main problem is to identify the shape and type of ice accretion.

M Friedlander, France. Are there any figures for the number of missions per year during which icing conditions prevent helicopter flying.

Authors Reply. We have no clear indication of the number of flights stopped.

Maj D A Abbott, USA. As a representative of the meteorological community, I think that providing forecasts of probabilities of temperature and LWC is an easier problem than providing forecasts of type and intensity of icing. If this better meets operational needs, then statements of requirements for meteorological support must be changed to reflect the need. Today's statement of requirements tend to be a deterministic (yes or no) forecast of icing. These will be pessimistic and have limited operational utility. In principle, one can use a probability forecast plus an assessment of the "Dollar" value of a mission to make decisions.

Authors Reply. Yes, I agree, when asking for forecasts in terms of LWC and temperature these should ideally be linked with a probability so that the operator can make his own assessment. But I was also trying to emphasize that it would be valuable if the forecasts were given in terms which could be related to the likely hazarding effect on a particular helicopter.

S T Andrews, UK. If you do not have the information on how many sorties are abandoned due to icing conditions, do you have any proposals on how we should collect the information, to get some idea of the size of the problem. It would be too late to worry about this lack of data once a war started.

Authors Reply. The information is available if all the operational records are gathered together. We are at present collecting ice and snow encounter reports which hopefully will show the extent of inflight encounters, and these also show whether a sortie was abandoned. What we have not accumulated is a record of the number of flights never started, but I would guess that 3-5% of the total sorties are abandoned for this reason.

Lt Col P E Argue, Canada. In Canada the Armed Forces are prevented from flying helicopters in visible moisture if the OAT is between -2°C and $+2^{\circ}\text{C}$, do similar restrictions apply in the UK for overwater flight?

Authors Reply. As I understand it, you are asking if we experience freezing rain between -2°C and $+2^{\circ}\text{C}$. No, we have no such restrictions on flight in rain.

R Adams, USA. The US Army data indicate that the Army fleet is grounded for 30% to 50% of the time in the winter months in Europe, due to icing forecasts.

Authors Reply. My earlier figures apply to RN operations over water, which tends to be a more benign environment. But it shows up the need for the data to be gathered.

A V Vastono, US. The US Army Agency for Aviation Safety did a survey about two years ago on missions aborted due to icing and the conditions experienced. This information is stored in a computer bank at Fort Rucker and should be available for reference. My experience of torque rise due to ice is that there is less rise due to clear ice than rime ice, however once shedding has started it does not matter what ice is there, the problem is vibration. It is this which terminates the flight.

Discussion

R I Adams, US. The criteria recommended in the Lockheed report, referred to in your paper, are based on statistical analysis of meteorological data over a 100 year period and intended to represent the 99 percentile probability for any place in the world. This is a guesstimate but the best we have available, it shows again the need to get together to come up with something we can all use.

Authors Reply. I agree.

A Hilsenrod, USA. The FAA is about to start a programme to obtain atmospheric icing data below 10,000 feet lasting for the next 3 years. Hopefully enough data will be gathered to give valid statistics. The NE coast of the US and Great Lakes will be covered initially.

Mme H Bouilland, France. You said that you found intermittent icing for 15 minutes. Can you say in more detail, whether this is a case found in normal icing and how many times such a condition was found in horizontal flight.

Authors Reply. We have not found this condition for long periods in horizontal flight, about 4-8km at present. We envisage that the helicopter might have to circle in that region however, hence the 15 minute criterion. We have not measured such conditions in our helicopters, but we have measured conditions close to the continuous maximum conditions.

| | |
|---------------------------------|--|
| ACCESSION for | |
| NTIS | White Section <input type="checkbox"/> |
| DDC | Buff Section <input checked="" type="checkbox"/> |
| UNANNOUNCED | <input type="checkbox"/> |
| JUSTIFICATION | |
| BY | |
| DISTRIBUTION/AVAILABILITY CODES | |
| Dist. | SPECIAL |
| 12 | |

DISCUSSION

E Carter, USA What was the weight penalty on the aircraft to provide the protection against hail, lightning.

Authors Reply 1Kg plus for lightning protection on the main blades, 3/4Kg for fuel tank protection, another 1Kg plus for each external tank. For the protection against hail, no extra mass is needed as the windscreen and engine inlets can take these impacts already, at the helicopter's maximum speed.

Maj J B Gartman, USA Why did you replace the composite materials in the fuel system by metal panels, as screening or conductive materials in the existing panels would have saved weight.

Authors Reply For the external tanks, which are laminated plastic, you have internal components which are metallic, like connecting pipes or the fuel gauge probe. Under no circumstances must the electric arc be allowed to reach these metallic components which are metallized to the aircraft structure. You must therefore change your tank into a Faraday Cage so that the electric arc stays on the surface, that is, put a surface conductor on the plastic tank.

A V Vastono, USA What type of protection do you have on the engine inlet against hail causing flameout, and do you have auto-ignition on the engines.

Authors Reply There are polyvalent intake on the engine inlets to protect against hail. M Lecoutre's paper tomorrow will give more details. A bullet closes, which protects against free stream particles and the perpendicular vortex tubes resist hail impacts of up to 45 metres/second.

P Ryder, UK What wavelength does your radar use, and what is the minimum precipitation intensity it will detect at typical ranges.

Authors Reply Two makes of radar have been certified for the 330J, the RCA Primus 40 and the Bendix 1400. But I cannot say what wavelength they use or their ranges.

D S O'Keefe, USA We have found, primarily in the Gulf of Alaska, a tremendous amount of static build-up which interfered with navigational equipment on some occasions. Are you involved also in trying to eliminate static electricity.

Authors Reply On the 330J Puma with the de-icing system, which has a lot of metal in the structure, specifically in the blade leading edge to protect against erosion, we had a few problems with static electricity causing a rise in high tension electricity for which, at the moment, we have no solution. This is a general problem for all helicopters with metal/composite blades.

Sqn Ldr R Tierney, UK In Section 3 of your paper, under Section dynamic response, you mention that the aircraft sideslips in a horizontal gust. Can you quantify the amount of sideslip and the lateral altitude change.

Authors Reply In the dynamic response, for a horizontal gust, the aircraft takes up a sideways position of 55° without automatic pilot and 30° with it, approximately.

J Clark, UK In one of your flights you identified fine ice crystals in the cloud. How were these identified?

Authors Reply We were able to take photographs and measure the size of the crystals, they were about 2 or 3 mm long.

Lt Col Fricker, FRG Do you think that by replacing some composite material with metal panels, that a mix of materials will have less benefit for protection against lightning.

Authors Reply The only plastic covered openings are the windows, that is transparencies below the cockpit, de-iced windscreens, certain access panels. We have changed accordingly mainly the access panels for the fuel circuit, if we had not we would have had to clear all the mountings carrying the pumps and indicator pipes, not in simulated tests using high tension but in current tests by showing there is no sparking along the pathway of the electric arc. It is evident that for a totally plastic helicopter, where a Faraday Cage effect is practically zero, we must completely protect the fuel tanks, all avionics especially that connected with digital calculations (CMOS and TTL circuits) and also the pilots since they will not have metallic canopy mountings.

J Lafont, France In the certification programme for the Puma 330J, the authorities have also asked for protection against hail, gusts and lightning. Is this official view an original one, or do other certification authorities also require this sort of protection from their national constructors.

Authors Reply This requirement was essential for certification, and it is up to other authorities whether they feel it necessary to do the same thing.

Discussion

J F Gayet, France. What sort of accuracy did you obtain in your LWC measurements and did you compare your "in-situ" measurements with FAR 25?

Author's Reply. No, we have not done that.

Sqn Ldr Lake, UK. Are you going to carry out your surveys, particularly in the central German plain at low levels, where the effect of land may be more marked than at the higher levels mentioned in your paper?

Author's Reply. In Southern Germany especially, the STOW and LEE effect cause vertical motion of the air, whereas in Northern Germany the curvature of airflow will be dominant and perhaps also vorticity in the frontal zone. We plan to fly this winter over Northern Germany to measure the coastal effect, too. Various other effects can be found: the soil, the air-pollution etc., but I think the most important influences on LWC are STOW and precipitation effects.

Dr P Ryder, UK. Have you tried calculating the adiabatic LWC in the prevailing synoptic situations?

Author's Reply. My aim is to get better forecast techniques. Although I know that LWC is important, I do not make more calculations of it. Our object is to derive realistic results from our test flights in the shortest time to derive better forecasts for the pilots.

A Hilsenrod, USA. It can be expected that under convective or upslope activity the cloud LWC will vary, depending on where the sample is taken. Do you intend to take OAT, LWC, drop sizes in various parts of the cloud?

Author's Reply. We try to gather as much data as possible. If we expect icing in cumulus we fly across the cloud to see how the LWC varies with position, time and altitude. But one of our problems is the limited air space over Germany, which makes the gathering of such data difficult. So we have very few data about this.

Maj D A Abbott, USA. LWC is a scale problem, there are large variations over small distances and over the cloud's life cycle. A statistical approach is needed to forecast LWC and give its probability of occurrence, the best method being multi variate regression techniques. This takes the most used predictors to try and derive methods of forecasting these probabilities. It is questionable whether it is better to predict LWC or the probability of icing.

Author's Reply. All our measurements are recorded and statistics are generated from this. However statistics can give you a median value but in cloud physics the spread around this value is very large. If you find the average LWC in cumulus is $.5 \text{ gms/m}^3$ you must also consider that 30% of the time it is $.2 \text{ gms/m}^3$ or $.8 \text{ gms/m}^3$ as the distribution is fairly flat. So although statistics are useful, we need other ways to predict the probability of icing.

J Bradley, UK. Your figure 4 says LWC is inversely proportional to time of activation of the ice detector. It seems to me that, for example, a time of 120 secs I would have a LWC of from $.5$ to 2.2 gms/m^3 !

Author's Reply. If you look at figure 3, the curve of LWC does not show much

variation except for some plotted points. That is because our computer programme was not good enough to exclude errors, made by any trouble of the recording system.

J Clark, UK. Are there any results from your oil slide analysis, concerning droplet sizes?

Author's Reply. Yes, there are some results, but they do not differ from other tests. I do not make use of them. They are not continuously measured, only 3 or 4 measurements during 10 to 15 minutes of flight.

Author: G F Barlow
J D Booker

DISCUSSION

S Ackley, USA. When you use icing rate indicators to measure LWC, you have to assume that its collection efficiency is fairly flat over a wide range of droplet sizes. Would you comment?

Author's Reply. The probes we use are fairly small and we assume their collection efficiency is the same over the range of droplet sizes that interests us.

G L Bender, USA. Do you get an in-flight reading of LWC from your Knollenberg instrument, if so what is the response time?

Author's Reply. We have not flown our Knollenberg instruments yet but hope to do so early in 1979. There will not be a direct LWC readout, it will be calculated after flight.

M Friedlander, France. We often speak of the static temperature (OAT) but there is a difference between dry air and humid air temperature. Do we take enough account of this, in other words is OAT sufficient?

Author's Reply. The basic temperature that you need is the static temperature of the atmosphere, although it is realised that different temperatures will be experienced on different areas of the aircraft and its rotor,

E Lozowski, Canada. In order to measure LWC and droplet spectra how do you account for the flow around the helicopter, especially the downwash from the rotor blade?

Author's Reply. We obviously have to mount any LWC or droplet size instrument fairly carefully, and experience has taught us to put them low and forward on the fuselage, perhaps on armament platforms, they are then clear of downwash except at very low forward airspeeds.

T Leeman, Holland. The instruments you mentioned are all fuselage mounted, where there is not too much of an icing problem. How do you read across to the rotor which may accrete ice sooner than the fuselage?

Author's Reply. The UK philosophy is not to measure the severity of icing on any particular part of the aircraft, but to measure the basic atmospheric parameters such as the LWC. The performance of particular rotors or protection systems can then be related to these parameters. Fuselage-mounted instruments of the aspirated type do not react as if they were part of the fuselage but 'see' the ice very early on. The idea of the induced flow is to create a high velocity over the probe so that the catch efficiency is high compared to that of the fuselage. The instruments thus behave more as if they were mounted on the rotor than on the fuselage. This is one of the fundamental concepts of, for example, the NRC/Leigh device.

P L Corley-Byrne, Canada. On the Leigh instrument the aspirator air speed inside the duct is about 325 ft/sec, the accretion time on the probe (at LWC or 1 gm/m^3) is about 2 secs. So your indication from the probe is very quick. The catch efficiency for 20 microns is about 97%.

A M I Chittenden, UK. Can you comment on the relative performance of the back-scatter device used on the DO 28 and the LWC devices you mentioned?

Author's Reply. I have no experience of the backscatter device.

Dr P Ryder, UK. We have a forward scatter, rather than backscatter device and a hot wire instrument on our research aircraft (C130). We have found extremely good correlation of LWC on a second by second basis, which at aircraft speed is equivalent to about 100 metres horizontal extent.

Author: J R Stallabrass
E P Lozowski

Discussion

P Corley-Byrne, Canada. We have tested the Leigh ice detector in mixed conditions and it tends to sense the water only and ignore the ice crystals present. We are not sure as to the exact mechanism.

E Carter, USA. Have you made any systematic studies of the effect of angle of attack on the way ice builds up on the airfoil, and how fast the airfoil degrades due to this ice?

Author's Reply. We have tested at varying angles of attack, but, as we have no balance system, cannot measure performance. We can only observe rate of icing and ice shapes.

B Perks, UK. Do you think there is any scale effect between the shapes shown for the rig work and those derived in the tunnel, due to the difference in aerofoil size? Also, your pictures of mixed conditions are very good, especially in showing the amount of ice bouncing off. However, in the comparison between rig and tunnel there was a significant difference in shape (fig 11) in mixed conditions, which could be more damaging than the more normal double mushroom shown in the upper pictures.

Author's Reply. There is obviously some effect due to scale; however, the tunnel model was a NACA 0015 aerofoil of 8.4 inch chord, while the flight results were from a NACA 0012 aerofoil of 16.4 inch chord. The effect of the smaller thickness ratio and the larger chord in the flight case made the two leading edge profiles fairly similar, so I do not think the difference in icing characteristics is too significant.

In answer to the second question, there does appear to be a rather more pronounced finger or peak in mixed conditions; however, the accretions are so much smoother and of smaller thickness that I feel sure they are less detrimental aerodynamically.

J Bradley, UK. The explanation for unilateral icing appears to explain some of the results that have previously mystified us. Has anyone with a good rotor head camera got some evidence, from spray rig work, that unilateral icing can be seen and identified?

Author's Reply. No, I have not seen any spray rig pictures showing this. One aspect of spray rig testing is that since there is no forward flight, there is no retreating blade stall, and hence no high torque rise as might be experienced in forward flight with similar ice accretions.

G L Bender, USA. Have you performed any work on the effect of droplet size on the shape or rate of ice build-up?

Author's Reply. No, in this series of tests we have tried to maintain droplet size at about 20 microns.

D Shepherd, UK. Speaking as an aerodynamicist I must express horror at the types of shape shown since their effect on the rotor is likely to be disastrous. The second point is on the suggestion that flight in icing should be continued with a fixed collective with speed being reduced. This approach defeats the purpose of an ice protection system, since one of its design aims is to recover, as much as

possible, the aircraft's performance envelope. Flying slower alleviates some of the problems of icing flying, and perhaps in the early days gave rise to false optimism that the problem was solved.

Author's Reply. I agree in general, although if there is nothing else available, that is to say unless a solution to the problem exists, reducing speed can be a way out of a sticky situation. However, the main point of my suggestion regarding retreating blade stall with small amounts of unilateral ice is that these high torque rises are a result of the inherent nature of the helicopters, and that we should not be looking for exotic meteorological explanations for them.

Discussion

P Kitchens, USA. How do you explain tip ice at fairly warm CAT's (-3°C), when classical heat transfer analysis indicates surface temperature should be much greater than zero.

Authors Reply. I rely on the evidence of Stallabrass, who mentioned very low temperatures due to the high pressure suction peak, this does not vary with temperature. I think, theoretically, that velocity in the maximum suction peak is such that ice formation can be explained. Certainly there is a UK paper which explains ice formation close to 0°C from this cause.

W P Brown, USA. Have you been able to relate loads on the starload indicator with the onset of ice accretion, and if so do you think this is an alternative method of detecting ice.

Authors Reply. The starload indicator shows rotor icing almost immediately, but it does not correlate to actual accretion. Our experience is that there is no correlation between any of the accretion instruments and the effect on the aircraft. Sometimes, with little or no accretion indicated, limiting torque conditions have been reached very rapidly without a corresponding large rise on the starload indicator.

R I Adams, USA. Have you seen any evidence of retreating blade stall in conjunction with the torque rise observed.

Authors Reply. Yes, quite often the spike appears on the starload indicator at the same time as torque begins to rise. As the de-icing starts to work this goes away and the torque comes down. We have also seen evidence of retreating blade stall without large torque rises and the converse, that is the vibration which characterises blade stall is not always present as torque rises. But massive torque rises are always accompanied by evidence of retreating blade stall effects.

M Friedlander, France. We have had an example during testing in France, of a partial blade stall, although there was no noticeable increase in drag, as seen by any torque increase. It was identified later as being caused by a large amount of water running back and refreezing at about 25% chord on the main rotor. This led mainly to a loss of lift but little increase in drag.

Discussion

J E Gardner, UK. The figures given in the UTTAS test programme were obviously the LWCs calculated from your speed and water flow, were any measurements taken on the test aircraft to correlate the LWC experienced to that being theoretically dispensed.

Authors Reply. No reply recorded.

D R Shepherd, UK. You said the maximum speed of the HISS aircraft is 125 kts. This is not sufficient for the full UTTAS envelope, how do you get over this?

Authors Reply. It is planned, this year to test at 90 kts and 120 kts, to see if there is any difference. You can go to much higher speeds in natural icing of course.

Sqn Ldr H Lake, UK. You have indicated that you hope to relate flying in natural icing to the HISS flying. In the light of the previous speaker, how do you intend to get such a relation, bearing in mind the limited flight envelope of HISS and the fact that turns cannot be attempted. Have you any plans to fully instrument your aircraft for natural icing flying, and also perhaps to have the same instruments on the HISS test aircraft.

Authors Reply. Once you have gathered ice behind the HISS, you are free to leave the cloud to investigate handling qualities, and we will do so. Correlation between the HISS and the natural environment will be difficult due to the latter's variability. The main thing is to get our droplet size close to that found in nature. The aircraft will be fully instrumented for performance and handling qualities as well as icing, although we are not sure yet what cameras we will use.

J W Sharer, USA. You mentioned the autorotational RPM degradation in icing. Was the degradation associated with any specific amount of ice accumulation.

Authors Reply. There was about 3/8" of ice on a particular station of the inboard third of the blade. An autorotation was initiated and aircraft landed, and amount of ice observed. This was rather crude but did show we could perform autorotations. On the UH-1 a 5 psi increase was about as high as we could go before we would lose autorotational rotor speed. We could not relate the degradation to type and amount of ice very precisely.

B Perks, UK. In broad terms, experience to date at A & AEE, has shown that you cannot relate degradation of autorotational characteristics to the amount of ice accumulated.

DISCUSSION ON SESSION III

1. Lt Cdr M J Hakes, UK. We can see that assymetric ice shedding is undesirable, leading to out of balance forces and hence vibration. We have heard references to opposite blade shedding to reduce this effect, which is readily accomplished with 4-bladed systems, but how do you cope when there are odd numbers of blades.

Reply from J C Lecoutre, France. It will be easy enough with three blades, as we have done, but as you say much more complicated with 5.

2. Squadron Leader Tierney, UK. In respect to the last question, span wise shedding would seem to be the answer. Secondly, for 3 years I have been involved in the testing and test flying of the Puma system and have reservations about the Puma control box. The control box doubles as an aid to fault analysis and takes a space of 9" x 5" (23 cm x 17 cm), this is the space used by 3 average sized radio controllers, the prime navigational aid in RAF Pumas, or the engine and fuel control panels. It seems unacceptable to me that a blade heating controller, used for a limited period in the year, should take up so much valuable space. I would therefore urge certification and design authorities to critically examine the required interface between pilots and system to minimise the space devoted to such controls and indicators.

Reply from J C Lecoutre, France. You criticise the bulk of the de-icing control system, and say it takes up too much space in the Puma's cockpit. In a way the control box, placed on the ceiling of the cockpit is very small, if you compare it with something of similar importance such as the met. radar which we have had to install. So we must compare like with like, and if we do so, the de-ice control is very small.

Reply from J Sladek, France. I would just like to clarify that with each piece of equipment there is a choice to make. If you want to increase the number of radios in the cockpit, then there will not be much space for other things. We can never equip ourselves completely with everything we want on board, there is a choice. If Sqn Ldr Tierney criticises the lack of space, it is because there was this radio already there and no space for anything else.

Reply from P H Bougon, France. I am replying concerning the reliability of the control system in the Puma 330J. For the civil version we have doubled up on the control electronics to assure a flight reliability against total electronic failure of 10^{-6} /flying hour.

Reply from D Shepherd. There seems little doubt these days that electronic functions are getting smaller, so I do not think there is any fundamental problem in making controls to fit in the cockpit.

3. S Brindley, USA. This question is for Mr Kitchens. Since Aerospatiale has stated considerable concern with lightning, hail and gusts, what is your comment on the US position.

Reply from R I Adams. The lightning problem is one that exists whether or not you have a de-ice system, however in our programme we concentrated on the icing problem, not lightning. There are other programmes, in the USA, concerned with lightning and static charge and discharge. The hail problem is in a similar category, there are design specifications for engines, windshields, etc.

4. S Brindley, USA. For Mr Shepherd - Did the tail boom photo-flash disconcert the pilot while taking pictures in cloud.

Reply from Mr Egginton, UK Test Pilot. No.

5. S Brindley, USA. For J C Lecoutre, your fig 1 depicts the FAR 25 maximum continuous icing cloud, fig 2 the intermediate maximum condition and fig 20 a number of test points that were accumulated in the testing phase. There is no reference to LWC in fig 20, however, what was the highest LWC encountered and approximately how many flights were in an LWC of more than $.5 \text{ gms/m}^3$.

Reply from J C Lecoutre. We encountered LWCs of up to 1.5 gms/m^3 .

Reply from J Sladek, France. At least 15 points on fig 20 were at LWCs of more than 1 gm/m^3 at temperatures of about -10°C . Quite a few points are at between $.5$ and 1 gm/m^3 . The lowest temperature was around -15°C with an LWC of $.7-.8 \text{ gms/m}^3$. About 70 hours were spent in icing in all sorts of clouds from stratus to the edges of cumulo-nimbus - we didn't penetrate to the middle thanks to the met. radar. We encountered severe enough conditions at the edges at 10-11000 ft at -10°C .

6. R J Humphries, UK. My experience in natural icing with unprotected rotors is that no two flights are the same, it is therefore important to make as many as possible. Only Mr Shepherd mentioned the total number of hours spent in natural icing. Could the other panel members do the same?

Reply from P Kitchens. We had around 12 hours during 2 years of testing, our maximum LWC being $.55 \text{ gms/m}^3$ in a very brief encounter.

Reply from J C Lecoutre. As M Sladek said previously we spend about 71 hours in natural icing.

Reply from E Eckert. The electrical system operating time was 25 hours and I assume it was switched on only during icing conditions. Our total flying hours were 166, so the number of hours in icing is somewhere in between.

7. J T Consdale, UK. This question is for Mr Lecoutre, how did you measure concentrations of 1.5 gms/m^3 particularly the test point in fig 20 which shows an intermittent maximum point at -3°C .

Reply from D C Lecoutre. An accumulation of 6mm/minute on a fixed probe at 120 kts was measured, so that our LWC figure is an estimated one not a precise measurement.

8. B Perks, UK. Three speakers have emphasised the need to relate the de-icing cycle to OAT and icing severity, whilst the Puma system uses only 2 cycle times plus an emergency cycle for very severe conditions. Would you comment.

Reply from P Kitchens. In our system the torque rises have been almost non-existent and I think as your on/off times are related to atmospheric conditions no large rises will occur. Although I cannot prove it I think much higher LWC conditions would have been catered for by our system..

Reply from J C Lecoutre. The fundamental element for "cleaning" the blade and reducing torque is the cleaning of the blade leading edge. On this winter's last flight in a very high LWC we saw evidence for the necessity of energising the leading edge strip twice in one cycle.

Reply from D Shepherd. From hearing the other papers, it seems to me that we are in similar situations. In most icing conditions a fairly leisurely operation is

adequate (2-4 minutes) and even unprotected rotors can survive. When severe icing does occur our experience is that torque rise is very rapid. In these situations, where rapid cycling is needed you must not squander time heating up elements longer than necessary to effect ice removal.

Reply from E Eckert. We found the most reliable indication to be the torque rise, and the ice detectors and LWC devices to be not quite adequate. We feel we know some of the results of icing and some countermeasures, but almost nothing on how accretions occur.

9. Mme Bouilloud, France. From your icing experience in the past, are you in any way able to define an authorised flight envelope in icing conditions, the corresponding operating regulations adapted to the available means of measuring icing.

Reply from D. Shepherd. The normal helicopter flight envelope is defined by such things as rotor system dynamic stall boundaries or control and handling factors. It is our objective in developing a rotor ice protection system to confer on the aircraft a flight capability approaching as closely as possible the normal IFR envelope for that aircraft. For that reason most of our testing is carried out within 5-10 kts of the IMC flight envelope for the rotor system. If one looks at the icing envelope, it is a function of altitude, LWC and OAT, and the test exposure you get is entirely dependent on the concentration conditions found in the trials. One must fly for many years and mount many trials to get enough flight experience in certain severities which statistics tell us will occur. Our philosophy is to evolve a cycle which will contain inherent features able to meet these requirements. Even so you might have to put forward, for approval, a system without having undergone the full spectrum of LWCs. The highest concentration occurs in cumulo-nimbus clouds and as M Lecoutre has pointed out, you do not intentionally fly into these clouds, for other reasons than icing. The amount of test flying in a reasonable period must be negotiated with the certification agency. This will involve engineering judgements based on an assessment of the test flying and an interpretation of the mode of operation of the system, its capabilities as assessed against the general state of the art.

Reply from E Eckert. Our position is similar to the UK's, that is we would like to explore all environments but are heavily dependent on the weather being available. Extrapolations are very difficult, if not impossible.

Reply from R Adams. US Army testing so far has been only from the research and development standpoint, we have not been trying to certify that particular aircraft. We are going to try to learn how to certify aircraft this winter based on our own and other countries' experiences. The FAA is participating in our programme and we hope to establish joint military/civilian regulations.

10. J R Stallabross, Canada. The chordwise method of shedding seems to involve a very complicated heating sequence to cope with the various icing conditions. It seems to me this complication is overcome by the spanwise method. In addition, if high torque rise is caused mainly by ice in the tip region, the energisation of the outboard section on the spanwise system should alleviate the problem.

Reply from D Shepherd. Yes, I agree that performance degradation is concentrated in the tip area and certainly preferential cycling in this region, within a longer period cycling, would be useful. One possible problem of the chordwise system is that if runback occurs you cannot delay the aft matting and remove it periodically.

Reply from P Kitchens. I would like to point out that the runback problem we have had is strictly an inboard phenomenon due to the design and production of our rotor blades being at the lowest cost. In production this would be different. We have not seen tip area runback at all.

Reply from D Shepherd. I was talking mainly about the possibility of runback which might accrue during very rapid cycle operation. In high LWC conditions there is also the possibility of water being released in the vicinity of the blade leading edge and at the blade surface which may be a source of runback.

11. F S Atkinson, UK. There are now about 1000 aircraft movements per day servicing North Sea oil rigs, and the limited icing clearance obtained at present means that these movements are severely restrained in icing conditions, since it is not allowed to change altitude or course to avoid icing. The objective is the all weather helicopter, which includes de-icing, weather radar, area-nav. and radio equipment and probably a flight director - all of which takes up cockpit space. With reference to an early question, it is not just a case of leaving another system out if space is to be found in the cockpit for de-icing controllers and indicators. All these systems are needed, at the lowest weight and cost. Could you therefore give some idea of your respective system's cost.

Reply from D Shepherd. We are working towards a service system, but as yet have no idea of the cost. It may well make a big difference if an icing system is designed in from the start rather than added later. The number of systems sold will be important so as to amortise costs. I can see that North Sea oil operators need some sort of icing system, but cost would depend on the market and standard of fit.

Reply from E Eckert. We also have only a test system flying and so although it has been made ready for production it is not in production. However, it weighs 32.5 kg and I know there are some calculations which give the cost of systems per unit weight, so perhaps this could be used.

Reply from J C Lecoutre. I am afraid I do not have any figures for cost of the Puma system. The French army has had 3 systems for the last few months and has accumulated around 250 flying hours.

12. P H Bougon, France. This is for P Kitchens. For six years the US Army has performed research into the chordwise de-icing system. However for the US Army UTTAS, Sikorsky has chosen a spanwise system - could you explain.

Reply from E Carter, USA. The decision was probably based on Sikorsky experience with the existing system on the S61CH, which incidentally is a 5-bladed rotor (ref question 1).

13. P R Cowling, Canada. This is directed at Herr Eckert. Could you please comment on the effect of ice build-up on the unprotected horizontal stabiliser and indicate any tests carried out to show that if the ice build-up occurred it would not cause handling or performance problems.

Reply from E Eckert. Sorry, we do not have any data on that question.

Discussion

Lt Cdr M J Hakes, UK. We heard that on the electro-thermal de-icing systems 2-3 watts/cm² is needed. UK/US microwave safety levels are 100 watts/m² or 10 mw/cm² (microwave ovens being less than 5 mw/cm²). What is the anticipated microwave leakage from the blades? How can a RF radiating system also be consistent with an aircraft operating in radio-quiet conditions?

Authors Reply. This was a concern of mine early in our work, and it was determined that if your hand was placed on a blade, with the system switched on, you would feel the heat, just like on a stove. There should be no other effect.

Dr O H Wyatt, UK. Is your system intended to be anti-icing or de-icing? What specific power for generators has been used for the weight estimates of the various protection systems.

Authors Reply. The system is intended to be de-icing. The ice is allowed to build to a certain thickness, then using an ice detector of possibly the reflected energy from the microwave signals themselves, the system is energised to induce shedding. An anti-icing system would very likely induce severe runback. The 300 amp DC generator on the VH-1 weighs 47 lbs, the 30 KVA generator on the test helicopter weighs 67 lbs, but is a rather old design. I believe a Bendix system weighing 26 lbs for 30 KVA is now available.

J R Stallabrass, Canada. You claim a power saving of 80% for the microwave system over the electro-thermal systems. I understand that the conversion efficiency from electrical to microwave energy is around 35%. How do you reconcile these figures.

Authors Reply. I agree with your figures, and this was discussed in early development, but the total energy requirement is still very small. I refer you to ref 9 and 10 which goes into more detail.

E Carter, USA. Do you see chemical systems being reconsidered in the light of new technology.

Authors Reply. In our trade-off analysis 4 years ago, a chemical system, ie fluid exuding through holes, was considered. The problem foreseen was dispensing the fluid in the proper manner. The best way was with a porous leading edge, which was not good from the erosion or blockage viewpoint. It also weighed more than an electrical system.

Author: J H Sewell

Discussion

R W Luidens. Have you considered exuding materials to break the adhesion bond between the blade and the ice.

Authors Reply. I imagine you mean some kind of porous coating which releases a freezing point depressant material. We have looked at this, in fact the pastes we have do just that. The trouble with exuding materials is that air pressure can make it exude in the wrong place at the wrong time, when ice is not there. It must also exude at a constant rate to avoid ice sticking to a dry surface.

NATIONAL APPROACHES TO CERTIFICATION

Mme H Bouilloud, France

French experience is limited since we have only tested on the SA330. For the Puma certification, the basic requirement is the FAR 29. However this chapter of the FAR leaves the firm free to claim or not claim an icing clearance.

Aerospatiale laid claim to a clearance without limitations in icing conditions, consequently the Authorities, for the first certificate of this type for a helicopter, asked for a basic requirement, close to that originated for aeroplanes, FAR 25.

In the same way the paragraphs in FAR 29 referring to windscreens, engines, air inlets, static and dynamic probes, rotating surfaces, general behaviour of the helicopter have been attributed as a special condition, taking as a reference the atmosphere of appendix C of FAR 25.

Towards the following a second Special Condition has been called for relating to the phenomena associated with icing such as lightning, hail and gusts. This condition requires a mode of protection to minimise the risks connected with these atmospheric conditions

I will speak now only of the proving against icing

Firstly the engines and their air inlets simultaneously met satisfactorily, in an icing altitude tunnel, tests in extreme conditions ensuring a qualification without limitations. This is to say 30 minutes in icing alternating conditions (a succession of continuous maximum and intermittent maximum clouds), the criteria being that the engine parameters should demonstrate satisfactory functioning and that the pressure loss in the air inlets should never go beyond the maximum determined value. In addition to wind tunnel tests the engines must prove they can function satisfactorily on helicopters in natural icing. Concerning the rotors, the big problem is in the fact of not being able to prepare basic tests (as for the engines or aircraft wings) in icing wind tunnels for the whole flight envelope.

For a first try the tests at Ottawa were very useful to validate flight in hovering conditions. For forward flight the only practical method is again, at the moment, qualification by flight in natural icing. The Puma tests lasted 4 years and although the certification has been acquired, this testing will be continued in order to accumulate the maximum experience.

This method is not economic, it does not satisfy everyone, for it is not reasonable to hope to find during the test periods the worst icing conditions. This method is also very long, and it does not make the development of systems very easy, but is today the only practical one. The lack of protection on the empennage has been justified, as on fixed wing aircraft, by flight in dry air, with simulated ice, and the evaluation of handling qualities.

We hope for future helicopter programmes to be able to use results of fundamental studies permitting the validation of a new method of demonstrating with basic tests on complete helicopter rotors at reduced scale, and also on some full scale blade elements. These studies have been interrupted in France for 18 months, and have not yet been resumed. The Certification Authority nevertheless is building much hope for such a demonstration method called "Aeroplane Type" which would allow a

reduction in the duration of tests of helicopters in natural icing conditions.

Taking into account the present state of knowledge and research in such areas as:

1. the definition of the atmosphere,
2. requirements adapted to the operational missions of helicopters,
3. the demonstration methods.

the Certification Authorities are not considering and are not in favour of fixing a rigid framework of certification methods. The French Certification Authority has been able to work in a satisfactory way with the method taken for the Puma, but hope to find a method, better adapted, and above all shorter, for future programmes.

J Bradley, UK

The views stated are those of the speaker and do not necessarily reflect the A & AEE or MOD(PE) official policy.

Let me start by outlining two points on the subject of certification generally. Firstly, at present there is no artificial icing facility which can replace natural icing for certification purposes. Secondly, it is difficult to see how any clearance for flight in icing can have the normal level of confidence associated with it which we like to work to. The user who accepts an aircraft with some sort of icing clearance, does so knowing that compared to other types of clearance there is a greater level of uncertainty associated with it.

Before we undertake certification trials there is a certain amount of preparatory activity, some of the more obvious points being:

- a. To ensure flight safety we have to ensure the adequacy of the engine protection using perhaps wind tunnel testing. If the engine does not have shields or screens, we have to know how much ingestion the engine can stand. We need to know what instrumentation is needed to monitor engine health.
- b. For rotors, whether protected or not, some accretion will take place, and it is necessary to know what limits can be flown to. This might be a flight envelope limitation, to cater for the earlier onset of blade stalling, stress limits, or performance degradation (eg when auto-rotation is no longer possible for single engine helicopters).
- c. Another point to study is the failure cases we will simulate in flight eg what de-icing failures or engine failures do we look at.

We then go flying in natural icing, in as many different conditions and to the maximum flight envelope possible. After these trials comes the difficult task of trying to assess what it all means. As a general rule we can say firstly, no certification unless a high level of engine protection has been achieved. Secondly the flight envelope in icing must have been shown to be adequate for instrument flying purposes. Thirdly how much is the fatigue life affected by the icing environment. Finally if unacceptable conditions arise, eg an excessive torque rise, it must be possible to exclude such conditions from the clearance offered. This could be difficult if a high torque rise occurs at low altitude, low weight at low speed.

To support certification, no firm rules are possible with regard to the number of flight hours needed, but it seems from experience that at least 30-50 hours in natural icing is indicated. We can say, however, that any experience must be over fairly small OAT increments, down to the lowest temperature required. The duration of icing encounters must be commensurate with the time for which certification is sought. The values of non-dimensional weight ($\frac{W}{S}$) for which clearance is sought must be supported by test evidence. Another problem is if the test vehicle only encounters LWCs up to a certain percentage of that required for certification; my personal view is that as long as at least 50% of the maximum LWC is encountered, for sufficient lengths of time, then I feel that some form of certification is possible in the context of a clearance with a "lower than normal" level of confidence.

Finally, I have made no difference in defining airworthiness standards between protected and unprotected rotors, and this is right since the certification agency is only presented with a system to be cleared. However with the cost and complexity of these systems, the user is going to demand some assurance that he is getting value for money. This is still an open question, to us, how do you frame an economical test programme that will enable the cost effectiveness of the rotor protection system to be appreciated? From the airworthiness viewpoint we do not account for the higher standard expected from a protected system - it is perhaps up to the customer to specify what he wants it to do, within his cost/performance constraints.

J Tulloch, USA

In March this year I was asked to look at how we should certify the Black Hawk for flight in icing conditions. After reviewing the FAR 25, and available reports we came up with the following programme. We have divided the testing into three phases, the first one being system checkout and the responsibility of the contractor. He has the opportunity to ground and flight test his machine for final tuning of the system. He also does EMI testing and prepares some fault analysis studies which are made available to us.

The second phase uses the HISS to investigate a matrix of test points composed of OAT against LWC. Since we have a "production system" to evaluate we will give it a rigorous test; starting off at -5°C .75gm/in', -10°C .5gm/m', -15°C .25gm/m'. From these points we will investigate lower LWCs at colder and warmer OATs. The true airspeed will be 90 knots, limited by the HISS clearance, although we will investigate one of the previously mentioned points at 120 knots to see if there is correlation. If there is no change in accretion and the system continues to function properly, we will continue at 90 knots. If there is a change we will have to pause and review the position. The helicopter we use will have a full instrument fit, which will be used to evaluate its performance and handling qualities. Some qualitative judgements of other features on the vehicle will also be looked at. The gunner's door accretes ice in its runners or door jamb, the ability of the pilot to jettison his and the co-pilots door, a cargo hook operation and whether cockpit heating, panel layout and lights are adequate. Failure tests will also be held of electrical items detailed in the operators manual as being a crew task to rectify.

We have structured our programme so that if we have not completed our test matrix, but have confidence in a particular system, we will proceed with natural icing flights, whilst still at the HSS test centre, if the opportunity arises.

When we have accumulated all our test points we will relocate to the natural icing test centre in New York State. We will proceed with a test matrix similar to that used with the HISS, although of course, we will have no control over LWCs and only limited control over OAT. We will be looking for correlation between the HISS and natural icing results. We will accumulate as much data as possible and then pass it on to the appropriate authority to decide whether it is sufficient to allow certification.

P Cowling, Canada

My responsibility in the Department of Transportation is only for civil aircraft and my comments will be of a general nature, not linked to a specific programme. They will be somewhat brief since we have not yet certified a helicopter for icing in Canada.

We do not, at present, have regulations specifically related to type approval or operation of helicopter in known icing conditions. Our approach is to review data, submitted by the applicant, in conjunction with any special conditions specified by the certification agency.

In formulating our own requirements we are of the opinion that a logical first approach would be where the icing requirements of FAR 25 are superimposed on the basic helicopter certification requirements. This requires a demonstration of satisfactory operation under the conditions specified in appendix C of FAR 25, and includes demonstrating the system in natural icing. Additional dry air and wind tunnel tests would be carried out and, if necessary flight with simulated ice shapes, to determine the vehicles performance and handling characteristics.

In the past we have used the FAA advisory circular AC20-37 as a guide in determining the adequacy of the certification programme for fixed wing aircraft and we think this could continue to be used for helicopters. It has not been, however, our practice to recognise certification in conditions of limited icing. The symposium has concentrated on large or multi-engined vehicles, we think thought should be given as to whether small, single engine vehicles can be certified, in view of their inherent lower level of safety. A similar approach to that used on fixed wing should be acceptable. In conclusion, and as far as Canadian operation is concerned, it should be noted that although a helicopter may be type approved for operation in icing conditions in Canada, additional limitations may be imposed by our operating requirements. An example is in commercial service where at least two engines are required for IFR flight, and hence also for operation in icing conditions.

E Eckert, FRG

We have two authorities in the FRG, civilian and military. The certification starts with a requirement from either side, in the case of my paper on the B0105 it was a military study which started the process. This study showed many areas of possible improvement and so a programme was started on the experimental side, also military, in conjunction with the companies concerned.

Ground tests on particular items are evaluated first and, if necessary, certified. The system is then assembled on the vehicle which is then evaluated against its original flight envelope, starting in safe areas and progressing to the maximum performance commensurate with safety. In icing, we lack the fundamental laws for modelling accretion, so that the normal process is somewhat reversed. The effects of ice are observed and steps taken to develop countermeasures, and then trying to derive laws to link the effect and remedy. The whole development is in small steps. As Mr Bradley said, the first essential is to keep the engines running.

Sqn Ldr H Lake, UK

We have made an attempt to state requirements that we think will provide aims for designers and testing agencies. I believe realistic requirements could be formulated around the view that the aircraft should be able to operate continuously at maximum continuous icing and should be able to survive maximum intermittent icing. This would encourage manufacturers to produce systems, similar to those described today, with a "panic button" to at least survive if all goes wrong in a condition the testing agency has not been able to investigate.

I feel that the Black Hawk programme does not seem to be identifying incipient problems during testing, so that if you do get into trouble, this could not be related back to the testing in the HISS for example. It is the operators who will be taking the risks, and I think that at the beginning of operation some form of recording should be possible. If trouble then arises, the test agency will have some indication of where to look for solutions, instead of looking for parameters it does not know.

I agree entirely with Mr Le Sueur that one of the fundamentals not mentioned is performance degradation, and this has to be spelt out during certification. Finally, there is the problem of instrumentation required in order to comply with the certification programme. The measurement of the environment is probably of little use to the operator, he is only interested in the effect on the aircraft. It seems to me that something like a cruise guide indicator tuned to detect performance degradation could be appropriate. If the parameter is to be torque rise, then a performance computer is necessary to indicate the loss of performance.

Cdr M E Southgate, UK

We have said, in the UK, that natural icing is essential for certification, and it is difficult to achieve the number of hours required. I think in icing certification, more than in other certification aspect, we have to integrate more the development, certification and user processes, all three being involved in the certification process. At an early stage of development the certification agency has to identify what it is looking for, the instrumentation required and the test envelope it will work to. This will enable the contractor to incorporate instrumentation which provides data for the final certification tests. When certified, the release will have a certain degree of confidence, and the only way to increase this is to build up experience, and as Sqn Ldr Lake said, to record, at least initially, the encounter experiences. The accumulation of test points, in this way, will eventually give much more confidence in the release, and perhaps enable you to expand the envelope further.

D R Shepherd, UK

I am not sure I agree with the statement that performance was not being considered at this Symposium. The measurement of rotor torque is very much part of the performance of the aircraft, and at least three of the systems described today have features introduced to control or contain torque rise. The Puma has a panic button to double the leading edge cycle, the BO105 signals the system on torque and the WHL system has explored cycles which take specific account of high torque rise situations. All these have the objective of containing performance degradation.

R W Luidens, USA

This is addressed to Mr Bradley. It appeared that you are prepared to accept less than the maximum LWC conditions in natural icing for certification, that is only 50%. Would you prefer this or 100% LWC behind the HISS, and if so why? Also why do we insist on icing and not try for better simulations.

DISCUSSION

M Friedlander, France

I would like to comment on the basic philosophy of certification. Mr Bradley spoke of the degree of confidence not being too high at present. For a civil certification we need to guarantee above all a minimum level of security. This minimum level should be equivalent to those demanded by other certification aspects for the basic vehicle or of its derivatives. Secondly, it is clear that we cannot compare the total experience we have accumulated on our helicopters, to that obtained on fixed wing types in the last 40 years, we have perhaps a million flight hours to catch up. Thirdly, if we compare our safety level with that of fixed wing types, we must do so with those of similar type and performance. For example, twin turbine non-pressurised aircraft of equivalent weight, speed and altitude capability, such as the King-Air. If we look at the ease of flying these types in icing conditions, especially in FAR 25 maximums, we can say our helicopter trials have not shown any great differences. We can say also that our lack of flying time is mostly counterbalanced during certification tests by the extra special care taken on the tests and on all the questions we are able to ask. A twin turbine helicopter is certified in 3 years, after 8 or 10 years normal testing, whilst equivalent fixed wing aircraft are certified for icing in five flights.

Finally, I would say that the test programme we would mount to certify a civil helicopter can be closely modelled on that for a fixed wing type, at least in its outline. That is we look at the helicopter's configurations, its flying areas and demonstrate its failure cases, taking into account, of course, the different icing conditions and temperatures. We can formulate a logical test programme which will be of the same form as that of a fixed wing type, even if technically we have to keep in mind the different points that are special to helicopters.

H E le Sueur, UK

Contrary to what Mr Bradley said there are existing requirements for helicopter icing certification, namely the BCARs. I would like to quote from paper 610 about aspects which I think have not been brought up at this Symposium. In para 3.1 of our proposed chapter G4-7, which is almost identical to chapter D4-7 for fixed wing types, it says:

"It shall be shown that the stability, vibration and control characteristics of the rotor craft will not be critically affected by a moderate accretion of ice."

I was therefore appalled to hear that one helicopter discussed could not sustain proper autorotative characteristics after ten minutes in icing conditions - I hope this is not the normal case. "The design features of the rotocraft shall be such as to minimise the hazards of flight in ice forming conditions." The CAA have approved the Sikorsky S61N to fly in light icing conditions and it can be stated that this vehicle meets the requirements of paper 610 in full, because we have put on a limited clearance. It can carry a moderate accretion of ice without affecting its stability, vibration and control characteristics.

The icing envelope in the papers has followed the lines of Mr McNaughtan's paper, excepting the snow criteria, which we intend to make heavier. I am also not sure if his periodic icing is pertinent when it comes to testing an aircraft in the continuous maximum conditions for the required period. One other point is that I do not think anyone has really addressed the subject of failures, although Mr Tulloch would appear to be starting this next winter. Finally, before certification, we would want to know the effect of ice on the aircraft's performance.

Reply from Mr J Bradley, UK

We would welcome better simulation to make better use of our resources. Our insistence on natural icing stems from our unfortunate experiences with the Spray Rig, where although able to contain icing in the rig, we were in trouble in the same conditions in natural icing. We have no experience of the HISS but would like to see the correlation between it and natural icing to give us confidence that it is right. One thing we have learnt in the UK is that if, say at -5°C , you fly out of icing to do performance checks, you lose a lot of ice, and we feel this is a major problem of the HISS.

As to the first question I did say I was very guarded about the 50% of maximum LWC as being a firm figure. It is just that we have done an awful lot of flying without seeing maximum LWC conditions, and would prefer to give some sort of restricted release, rather none at all, even though it has an element of uncertainty.

Perhaps when Mr Tulloch has performed his test programme we will know more about the usefulness of the HISS, and its correlation with natural icing.

Mme H Bouilloud, France

I would like to say something in reply to Cdr Southgate. It is evident that when we start a natural icing test programme, an objective programme ought always to be defined. The wish of all the experimenters is to get as close as possible to these conditions. From this point of view there is no need to be worried, the constructors and official services test centres try their hardest to find the most severe icing conditions. As for instrumentation it is apparent from all the papers presented, that all the helicopters are very fully instrumented. I would also like to give more precision to something else Cdr Southgate said. It would be very interesting to be able to exploit the icing conditions encountered during natural icing tests, independently of the studies the meteorological authorities should make, in order to complete the knowledge of the icing atmosphere. In relation to this, four Pumas will this winter in France be equipped for flight icing conditions. These will be little instrumented, and they will not be able to measure everything or to give very precise information on the icing conditions encountered, but the pilots will try their best to describe the icing and fill in forms for statistical purposes which will help us in the future.

One point on Mr Shepherd's remark. The Puma's protection system was developed until it was satisfactory. That is until it could give acceptable changes in the helicopters performance. If the important changes had been found which were unacceptable the certification would not have been given. A measured torque was not required in the basic definition of the helicopter's certification, this was because the critical value was not reached in the explored regime. The sum of the test points that we have gathered, have, even so, given us sufficient confidence to provide for authorisation of this certification. It is certain that we do not pretend to claim that we have foreseen everything, we are going to observe and follow very closely the tests which will follow. This authorisation for flight in icing conditions was given with a certain degree of confidence and will allow an increase in helicopter flight experience in the most various icing conditions. This always a risk when one is the first to enter a new flight regime, and we have taken the minimum risk possible.

SYMPOSIUM THEME

Earlier conferences such as at Ottawa in 1972 and Edwards AFB in 1974 have considered various aspects of the helicopter icing problem. The helicopter icing group of NAAG Panel X considered that it was timely to review progress in the years since and agreed to sponsor such a meeting. An AGARD meeting in April this year focussed on engine icing aspects. This symposium therefore reviews the problems of rotor icing with particular emphasis on rotor blade protection methods, design criteria, system concepts and capabilities and test certification methods.

CONTENTS

PANEL X SUB GROUP

THEME

SESSION I – THE PROBLEM

HELICOPTER FLIGHT IN ICING CONDITIONS: REQUIREMENTS AND PROBLEMS.

by Commander M E Southgate RN

ATMOSPHERIC CONDITIONS FOR HELICOPTER ICING PROTECTION DESIGN.

by I I McNaughtan

PROBLEMES LIES AUX, CONDITIONS DE VOL EN ATMOSPHERE GIVRANTE: FOUDRE, GRELE, RAFALES (PROBLEMS ASSOCIATED WITH FLIGHT IN ATMOSPHERIC ICING CONDITIONS: LIGHTNING, HAIL, GUSTS).

par J C Lecoutre et P H Bougon

COLLECTION OF METEOROLOGICAL DATA IN ICING CONDITIONS IN THE FRG WITH A DORNIER DO 28.

By W Fuchs

SESSION II – INSTRUMENTATION AND TEST METHODS

ICING INSTRUMENTATION.

by J D Booker and G F Barlow

ICE SHAPES ON CYLINDERS AND ROTOR BLADES.

by J R Stallabrass and E P Lozowski

TECHNIQUES FOR ICING TEST FLYING.

by G V Ray

HELICOPTER ICING SPRAY SYSTEM.

by Lt Col A R Todd

SESSION III – ELECTRO-THERMAL BLADE PROTECTION SYSTEMS

APPLICATION OF THE SPANWISE ROTOR BLADE DE-ICING CONCEPT.
by P F Kitchens

**SYSTEMES DE PROTECTION CONTRE LE GIVRE DU PUMA
(PROTECTION SYSTEMS AGAINST ICING ON THE PUMA).**
par J C Lecoutre

UK ROTOR BLADE PROTECTION.
by D Shepherd

ROTOR DE-ICING ON THE BO-105.
by Lt Col H Melcher

SESSION IV – OTHER METHODS OF BLADE PROTECTION

US DEVELOPMENTS IN THE AREA OF HELICOPTER ICE PROTECTION.
by R I Adams

THE DEVELOPMENT OF NEW ICE-SHEDDING SCHEMES.
by J H Sewell

SESSION V – CERTIFICATION

DISCUSSION PANEL – NATIONAL APPROACHES TO CERTIFICATION
Speakers from UK, USA, Canada, France and FRG
(A record of this session will be sent out to attendees at a later date).

(v)

THE REQUIREMENTS AND PROBLEMS OF HELICOPTER FLIGHT IN ICING CONDITIONS

COMMANDER M E SOUTHGATE RN

Directorate of Helicopter Projects
Ministry of Defence (Procurement Executive)

SUMMARY

Various military and civil operational requirements exist for helicopter flight in icing conditions and these cover a range of mission profiles and geographical areas. These conditions can have hazardous effects of differing severity on various parts of the helicopter. Within the constraints of existing instrumentation, test facilities and other certification problems, the capabilities of current helicopters to fly safely and survive encounter with icing and snow appear to vary considerably between types. The lack of climatological data and inadequate forecasting techniques make difficult the regulation and control of such flying. The probabilities of a hazardous encounter and the penalties involved in providing protection have to be considered by the operator in trade-off decision on equipment fit.

1. HISTORICAL BACKGROUND

Work has been proceeding with varying degree of urgency for more than 20 years to provide full capability for helicopter flight in icing conditions. The pressures for this in the UK have increased considerably in the past ten years since the withdrawal from the Far East theatre of operation and concentration of activities in the colder areas. At the same time capability for flight in IMC has increased with improvements in flight instrumentation, navigation aids and autostabilisation equipment. Similar pressures have come to the fore in other countries; for example in the United States with the move away from S E Asia. Thus at this point in time, there is a high priority requirement with most military helicopter operators and for certain types of civil operations for flight in icing conditions. However understanding of the problem and development of effective protective systems have not kept pace with these pressures and in general this need for improved operating capability has not been met.

2. EFFECTS OF ICING CONDITIONS ON HELICOPTER FLIGHT

The various conditions normally associated with the term icing in the broadest sense can have wide ranging effects but these can be summarised. The small supercooled water droplets, in what are icing conditions in the strictest sense, freeze on impact with the helicopter in varying form and size depending on conditions. With low inertia these droplets tend to follow streamlines and accrete more readily on thin sections such as rotor blades, landing gear struts, aeriels etc rather than on the blunt fuselage shapes. Snow, with its multitude of differing forms, can interact in different ways. Large wet flakes at the higher temperatures near the freezing point may well adhere and collect, particularly where the airflow experiences an abrupt change in momentum and direction whereas the smaller dryer flakes rebound and do not stick. Snow can be of particular concern close to the ground as the recirculation of fallen snow can cause very high local concentrations. There is need to pay due regard to other conditions such as freezing rain. With much higher droplet size and inertia such rain will tend to impact and coat all forward facing surfaces and high accretion rates are likely.

These conditions have the potential to inflict a variety of problems on the helicopter in flight. The engine can suffer internal damage from shed ice, flame out from sudden ingestion of large quantities of ice, snow or slush or malfunction from intake blockage. Ice accretions on the main rotor blades can cause degraded performance with consequent increase in torque demand, inability to establish auto RPM and a reduced flight and manoeuvre envelope. Rotor and control system fatigue damage can possibly come from the increase in oscillating torsional loads and vibration from assymetric build up and shedding. Snow alone is unlikely to collect on the blades and therefore should not affect rotor performance. Vision through the windscreens can be seriously impaired or blocked by ice formations. Collections of ice and snow on the fuselage may cause ingestion problems or impact damage on breakway. Extreme build ups on the forward fuselage may significantly alter CG position. There is possibility of icing up of exposed controls preventing operation and much more common are accretions on antennae with resulting vibration and structural failure. The military also have the additional problem of icing effects on the carriage, release and operation of weapons and stores carried externally.

This review of conditions and effects is a simplified one. UK trials experience going back over the past ten years has shown that there can be wide variation in effect in what appear to be similar conditions and conditions are themselves rarely consistent over time or distance. Though there is possibility of helicopters suffering the full range of these problems, it is by no means predictable that they will occur during encounters with icing conditions, particularly when these conditions are less than severe. The capability of the unprotected helicopter to survive and operate has not been fully explored. However it is vital that the engine be kept running and engine protection is essential as is the need to maintain clear vision. Protection methods here have much in common with fixed wing technology though intake arrangements and associated airflows can be more complex and engines are generally more fragile.

The rotor problem is unique to the helicopter and the development of a protection system poses an interesting challenge. The need for such protection in all instances can be argued. Size of helicopter, mission requirements, rotor operating conditions are some considerations which can influence the need. With the current state of the art precise assessment of requirement is difficult. There is still need to define more clearly and measure more precisely the atmospheric conditions involved and to determine the probability of encountering such conditions in the specified operating air space. However experience to date has clearly indicated that to survive and meet mission requirements during prolonged encounter with the worst of icing conditions, rotor blade protection will be necessary.

3. MISSION REQUIREMENTS

The problems of helicopter icing need to be considered against the mission being flown. These fall into several broad profiles and scenarios covering both military and civil operations.

3.1. Battlefield

The armed attack and scout helicopters, in their primary role against armour and troop concentrations, require to fly close to the ground preferably in visual contact over comparatively short ranges. This 'nap of the earth' role demands agile flight. These helicopters should be able to fly in this role at any time that the enemy and particularly his tanks are operating. In this situation snow is likely to cause more problems than icing since flight time in cloud will be limited. The need for blade protection here is debatable.

3.2. Support and Transport

The operational scenario for these helicopters could be similar to the attack role in the forward battle areas. However much more time will be spent operating over extended ranges at higher altitudes and icing becomes more of a potential hazard.

3.3. Anti Submarine

The naval anti submarine role over the areas of the northern North Atlantic, the Norwegian and North seas has a quite different pattern of operations. Much of the flying will have to be at altitudes up to 10000 ft to maintain communications. The flights are likely to be of long endurance over considerable distances, much in cloud under IMC. Because the probability of encountering icing conditions will be high during the winter months, overcoming the icing problem is a paramount

requirement and the need for rotor protection is therefore much greater and is considered mandatory. Here snow is unlikely to be a major problem.

3.4. SAR

This type of operation could cover both sea and land areas. Recovery will of necessity be at low level but transit and search may well extend over long distances and be at high altitudes. This type of operation could therefore demand the widest capability for flight in the full range of icing and snow conditions. In the maritime SAR mission which could be flown at low level, ie. below 2000 ft, blade icing is unlikely to be a problem.

3.5. Civil

Scheduled operations through busy airways under tight traffic control such as the inter city and airport operations are currently the most demanding of an icing clearance. Services in support of remote site operations such as to the North sea oil rigs are less demanding as there is greater flexibility in operations and a limited clearance can suffice. However as traffic density increases in these areas, air traffic control becomes more rigid and ranges increase, so will the demand for increased protection.

These missions are only a representative selection from the wide range of uses for the versatility of the helicopter. However they serve to indicate how primary mission influences the strength of need for an icing clearance. In the military mission accomplishment is the most important criteria. The US Army requires that its helicopter systems should cope in 99% of conditions encountered. This sort of requirement emphasises the need for much more information on conditions in the icing atmosphere since probabilities of encountering prohibitive icing have to be set against installed protective system penalties. Both the operator and those designing and developing the systems need to be aware of the trade offs involved. In civil commercial activities, apart from flight safety aspects, cost or profitability is probably the overriding factor.

4. CAPABILITIES OF CURRENT HELICOPTERS

The technology required to develop protective systems is available, perhaps arguably not in quite the most effective form, and the design principles involved are not complex. Yet the lack of accurate definition of the design atmospheric conditions involved and the difficulties of obtaining sufficient test results under full scale natural conditions have hindered proper development and certification. After many years of slow progress some current helicopter types do have capability for flight in icing conditions. Since 1973 British Airways Helicopters and Bristows have operated the S-61 with a limited icing release. This allows flight in light icing conditions down to -5°C at altitudes no greater than 5000 ft providing the freezing level is above 500 ft. This is with engine protection, windscreen heating and simple instrumentation to detect icing but no blade protection system. This clearance has been sufficient for the North sea operations to date and the number of sorties prevented has not been commercially significant. The CAA approved the release after BAH conducted flight test programmes for several years in parallel with Ministry of Defence work to provide the Sea King with a

similar clearance. This latter release has been improved since with further modification to the engine protection. In April this year the French Civil Aviation Authorities certified the SA 330J Puma with an unlimited icing release providing the full icing protection system, including electro thermal blade heating, is fitted together with the weather radar. This should read across to military operations of the Puma. In both France and the UK there has been close co-operation between the military and civil agencies with mutual benefit in achieving these releases. In the United States the US Army has been in the forefront in promoting programmes to provide icing releases for its aircraft and is looking for flight in up to 'moderate' icing conditions in the latest generation of its helicopters. Some in service types do have limited icing releases. However as yet there is no civil certification for any helicopter in the US.

5. CONTROL OF HELICOPTER FLIGHT IN ICING CONDITIONS

Current releases or certification where allowing limited flight in icing conditions are generally written in terms relating to assessment of severity ie. light, moderate or severe; in the measurable terms of altitude, outside air temperature, air speed and crude measurement of accretion rates and visibility. The use of factors requiring individual judgement can pose problems in the authorisation and control of helicopter flying in icing conditions. The severity terms such as light icing are used in forecasts usually covering large areas in a general way. This particular term for example is defined as $\frac{1}{2}$ " depth of ice collecting on a small probe over a distance of 40 nautical miles. Naturally the forecasts tend towards a pessimistic outlook and therefore appear unnecessarily restrictive when viewed against actual conditions. The operator when planning the sortie wishes to assess the effects of the conditions likely to be encountered on the helicopter being flown. What is hazardous to one helicopter may well be acceptable to another. Ideally forecasts should be in terms of measurable parameters primarily temperature and liquid water concentration which relate directly to hazarding effects. There is also perhaps a requirement for means for more precise on-board measurement of ice accretion rates or severity and such devices are becoming available in reliable form. Installed on all aircraft with an icing release they could provide much more positive control as well as providing valuable data on the atmosphere.

On-board weather radars have some use in the icing situation in that they enable the pilot to avoid the gross effects associated with the turbulent cumulus type cloud formations. However it is questionable whether they are of significant help in detecting icing conditions in layer type formations.

6. WAY AHEAD

This brief overview has identified some of the more significant problems involved in helicopter flight in icing conditions. Many of the problems arise because of the uncertainties surrounding our understanding of the icing atmosphere. If helicopters can be equipped with reliable, economical and effective protective systems so that they can survive and adequately perform their mission in the face of the worst of conditions then many of the problems disappear such as reliance on accurate forecasts and the need for much improved on-board instrumentation. Rotor blade protection is a necessary part of providing such overall capability for the helicopter which is expected to fly in such conditions for protracted periods. It is in this area that there is most development work to be done if acceptable systems from cost and installed penalty considerations are to be produced.

ATMOSPHERIC CONDITIONS FOR HELICOPTER ICING PROTECTION DESIGN

by

I I McNAUGHTAN

Royal Aircraft Establishment
Engineering Physics Department
FARNBOROUGH Hants

Abstract

The various atmospheric conditions in which icing hazards to helicopters can occur are reviewed and the parameters which have to be quantified for purposes of design specifications are identified - The derivation and definition of UK design atmospheric conditions are presented and their differences from US recommended icing criteria are discussed. The need for improved data on free water substance in the atmosphere is stressed and a proposal made that a Working Group should be established to define the parameters which have to be measured, the required accuracy and to recommend provisional atmospheric conditions for helicopter icing which can be used throughout NATO in the interim period.

ATMOSPHERIC CONDITIONS FOR HELICOPTER ICING PROTECTION DESIGN

1 Unprotected helicopters have been put at hazard when flying in the presence of supercooled water droplets, freezing rain, ice crystals, snow and mixtures of supercooled droplets and ice crystals or snow.

Some loose definitions to clear the air. Supercooled droplets are water drops in the size range from 2 or 3 microns up to about 100 microns in diameter which can exist at temperatures from 0°C down to about -40°C. Freezing rain occurs under temperature inversion and is water drops in the size range from say 200 microns to 1500 microns diameter at temperatures close to 0°C in air at sub-zero temperature. Ice crystals (Fig 1) almost defy definition as regards shape and have maximum linear dimensions from about 0.5 mm to 4 mm. At temperatures not too far from 0°C ice crystals which collide can fuse together to form snowflakes, so snow can be either single ice crystals at low temperature or agglomerates of ice crystals up to a few centimetres linear dimension at temperatures close to 0°C.

2 Although I have given, in broad terms, the atmospheric conditions causing icing hazard what aspects of each condition do we need to quantify for design standards?

Consider the power requirements of a thermal anti-icing system (Fig 2). The power required is (A) for melting, heating and evaporating the impinging ice/water and (B) for overcoming the convective heat loss.

(A) is a function of water type, temperature and catch rate: catch rate is a function of speed, water/ice concentration and catch efficiency: catch efficiency is a function of geometry, speed, water particle size and air density which is a function of temperature and pressure,

(B) is a function of geometry, speed, air density and temperature. Thus an icing condition has to be quantified in terms of water type, size spectrum and concentration, temperature and pressure.

Examination of the needs of other types of ice protection systems does not increase these quantifiable terms.

3 Given statistically meaningful data on the correlation, if any, of free water parameters, with temperature, altitude or cloud type and their variation with geographic location it would be possible for a meteorologist to come up with design standards of given exceedance probability. Unfortunately the data do not exist and a good deal of "guessimation" has been required in preparing the design standards to be presented.

4 I am aware that someone in this audience is thinking that during the recent AGARD specialist meeting in London on Icing Testing for Aircraft Engines an excellent presentation by Herr Vath on "Meteorological Icing Conditions" concluded with the statement "icing parameters applied throughout the world differ from each other, but these differences are so small that it should be possible to bring these parameters into line". He was referring to icing parameters for engines in fixed wing aircraft and the most severe of many of the fixed wing standards represent icing conditions at altitudes well above those in which the majority of helicopters operate and are therefore not applicable to helicopters.

5 This was realised about 7 years ago when A&AEE and RAE were tasked to derive ice protection requirements for UK Military helicopters. The work was done with the co-operation of the ARB (Now CAA Airworthiness Division) and in consultation with the Meteorological Office, NRC Low Temperature Laboratory and Westland Helicopters Ltd.

At that time there were no military or civil helicopter ice protection standards in the NATO countries so it was a case of starting from square one. The first decision made was that the altitude range would be limited to below 10000 ft. That eased the problem. We then divided the various icing atmospheres into types (Fig 3) which, for atmospheric physics reasons or due to helicopter operational procedures, could possibly have different characteristics, extents or durations. The next step was to search out available data for each atmospheric type and quantify, or guesstimate, the design standard. Those standard atmospheres are given in Table 1 which is an extract from AvP 970 Memo 35/R.

6 For the classical icing condition we went back to the original NACA data measured during 1948-52, on which both the UK and US fixed wing standards were based, and examined the data for altitudes below 10,000 ft. We also examined data from A&AEE icing trials of fixed wing aircraft and helicopters. This study indicated that the fixed wing Continuous Maximum condition (Table 1-I) was equally applicable to helicopters but that more severe conditions, in terms of LWC, were encountered for distances of 5-8 km within the Continuous Max condition. We named this the Periodic Maximum condition (Table 1-II) to avoid confusion with the fixed wing Intermittent Maximum which is applicable to altitudes above 10,000 ft and is much more severe in terms of LWC.

Comparison of the UK and US Recommended Icing Criteria (Report USA AMRDL-TR-75-34A) is interesting (Figs 4 & 5). The UK Continuous Max is for a 20 micron vmd only and the LWC is the same as the US LWC for a 15 micron droplet but more severe than for the US LWC for a 20 micron droplet. This is typical of the small differences Herr Vath referred to. Comparing the UK Periodic Max and the US Intermittent Max shows the UK LWC for the 20 micron droplet is less than the US LWC: it is about equal to the US LWC for 27 micron droplets.

7 Our freezing fog condition (Table 1, VIII) has no US equivalent but is based largely on US data. The freezing rain condition (Table 1, IX) differs slightly from the US proposed atmosphere at temperatures below -5°C (Fig 6).

8 Regarding ice crystals and snow, the UK fixed wing ice crystal requirements are applicable to altitudes of 15,000 to 60,000 ft and represent conditions in cumulo-nimbus cloud tops - hardly the right place for helicopters. Since initially in the study we had no direct measurement of low altitude ice crystal or snow concentration we resorted to a variety of methods of determining it, none of them very accurate. These methods included conversion of snow depth accumulation rate to concentration, conversion of visibility measurements to concentration and extrapolation of rain fall rates to sub-zero temperatures, assuming this to give snow mass fall rate and converting to snow concentrations. We were very pleased when, just at the right time for us, Jim Stallabrass of NRC developed an instrument for measurement of snow concentration and supplied us with his initial measurements of Ottawa snow concentrations. Extension of this work to European snow would be highly desirable. Fig 7 shows that our UK precipitating snow requirements (Table 1, V and VI) differ from the US requirement. The UK recirculated snow condition (Table 1, VII) is similar in concentration to the periodic falling snow condition: this is because pilots and flight observers have stated that the visibility, or lack of visibility, is similar in both cases.

9 The continuous and periodic maximum mixed conditions (Table 1, III & IV) are speculative. We do not even have an instrument which can quantify the liquid and solid contribution to a mixed condition. The concentrations quoted have the same total water content as the classical icing conditions with the ice/water ratio about 3:1.

10 In conclusion I would make the following points:

i There are not adequate data on free water substance in the atmosphere to allow derivation of statistical meaningful helicopter icing standards.

ii Investigations should be funded to acquire these necessary data. Consideration should be given to establishing a NATO Working Group to determine the best way of doing this work, to define the parameters which have to be measured and the accuracy of measurement required.

iii Since collection and analysis of the data will take some time - possibly measured in years - and since current proposed and recommended icing atmospheres have dis-similarities, the Working Group should also be tasked to examine existing data, proposed and recommended icing standards and to produce provisional atmospheric design conditions for helicopter icing which can be used within NATO in the interim period.

TABLE 1

DEFINITION OF DESIGN ATMOSPHERIC ICING CONDITIONS

| Condition | Air temp. °C | Water content g/m ³ | Horizontal extent km | Droplet size, median vol. dia. microns | Altitude range ft(m) | Notes |
|------------------------------------|-------------------------|---|------------------------------------|--|--------------------------------------|-------|
| I Continuous maximum icing | +5 0 -10 -20 | 0.90 0.80 0.60 0.30 | Continuous | 20 | 4-10,000 (1.5-3,000) | 1 |
| II Periodic maximum icing | +5 0 -10 -20 | 1.35 1.20 0.90 0.45 | 6 km every 100 km of Condition I | 20 | 4-10,000 (1.5-3,000) | 1, 2 |
| III Mixed conditions continuous | 0 -10 -20 | (0.20 LWC 0.60 ICE (0.15 LWC 0.45 ICE (0.10 LWC 0.20 ICE | Continuous | | 0-10,000 (0-3,000) | 1 |
| IV Mixed conditions periodic | 0 -10 -20 | (0.30 LWC 0.90 ICE (0.20 LWC 0.70 ICE (0.15 LWC 0.30 ICE | 6 km every 100 km of Condition III | | 0-10,000 (0-3,000) | 1, 2 |
| V Falling snow continuous | +3 to -20 | 0.8 | Continuous | | 0-10,000 (0-3,000) | |
| VI Falling snow periodic | +3 to -20 | 1.5 | 8 km every 100 km of Condition V | | 0-10,000 (0-3,000) | 2 |
| VII Recirculating snow | 0 to -26 | 1.5 | | | Hover in ground effect | 2 |
| VIII Freezing fog | 0 to -20 | 0.3 | | 10 to 20 | 0-50 (0-15) Above ground level | 2 |

TABLE 1 (cont.)

| Condition | Air temp. °C | Water content g/m ³ | Horizontal extent km | Droplet size, median vol. dia. microns | Altitude range ft(m) | Notes |
|------------------------------------|----------------|--------------------------------|----------------------|--|----------------------|-------|
| IX Freezing rain/ drizzle | 0 to -15 | 0.3 at 0° to 0.0 at -15° | 100 km | 200 | 0-5000 (0-1500) | 2, 3 |
| | 0 to -10 | 0.3 | " | 1500 | " | " |

Note 1: At altitudes below 4000 ft (1200 m) the maximum water concentration appropriate to the temperature decreases linearly with decrease in altitude to zero at sea level except that below 1000 ft the concentration for 1000 ft (300 m) applies.

Note 2: See Chapter 714 para.2.1.2.

Note 3: See Chapter 714 para.2.6.4 and also Appendix 714/2 para.6.

TABLE 2

RANGE OF DROPLET SIZES

| Droplet diameter d_f (microns) | % by weight of total water content contained in droplets of diameter d_f |
|----------------------------------|--|
| 5.4 | 3 |
| 11.1 | 8 |
| 16.6 | 20 |
| 22.0 | 30 |
| 27.8 | 20 |
| 33.4 | 10 |
| 39.0 | 5 |
| 44.4 | 4 |

The droplet sizes quoted in Conditions I and II of Table 1 are the median volume droplet diameters (d_v) for the distribution shown in Table 2; d_f is the particular drop diameter under consideration.

| | | | | | | | | | |
|--|---|--|---|--|---|--|--|--|--|
| | E1a Elementary needle | | C1f Hollow column | | P2b Stellar crystal with sectorial ends | | CP1a Plate with aciculi at ends | | IR Irregular snowflake |
| | E1b Needle of elementary needles | | C1g Six-lobed plate | | P2c Dendritic crystal with plates at ends | | S1 Side plates | | H6 Hexagonal prism |
| | E1c Elementary sheath | | C1h Three-plate of section form | | P2d Dendritic crystal with sectorial ends | | S2 Star-like plates | | L6 Lamp-shaped |
| | E1d Needle of elementary sheaths | | C1i Screw | | P2e Plate with simple extensions | | R1 Radiating arrangement of plates | | CR Combination of side plates, bullets and columns |
| | E1e Long white column | | C1a Combination of bullets | | P2f Plate with dendritic extensions | | R1a Radiating arrangement of dendrites | | B1 Blood needle crystal |
| | E1f Combination of needles | | C1b Combination of columns | | P2g Plate with dendritic extensions | | CP1a Column with plates | | B1b Blood columnar crystal |
| | E1g Combination of sheaths | | F1a Hexagonal plate | | P3a Two-branched crystal | | CP1b Column with dendrites | | R1c Rimed plate of sector |
| | E1h Combination of long white columns | | P1a Crystal with sectorial branches | | P3b Three-branched crystal | | CP1c Multiple capped column | | R1d Rimed stellar crystal |
| | C1a Pyramid | | P1b Crystal with broad branches | | P3c Four-branched crystal | | CP1d Bullet with plates | | R1e Densely rimed plate of sector |
| | C1b Cup | | P1c Stellar crystal | | P3d Broad branch crystal with 12 branches | | CP1e Bullet with dendrites | | R1f Rimed stellar crystal |
| | C1c Six-lobed bullet | | P1d Ordinary dendritic crystal | | P3e Dendritic crystal with 12 branches | | CP1f Stellar crystal with needles | | R1g Stellar crystal with rimed spiral branches |
| | C1d Hollow bullet | | P1f Fern-like crystal | | P3f Reformed crystal | | CP1g Stellar crystal with column | | S1a Snowflake with hexagonal plate |
| | C1e Hollow column | | P2a Stellar crystal with plates at ends | | P2a Stellar crystal with plates at ends | | CP1h Stellar crystal with plates at ends | | S1b Snowflake with hexagonal plate |

Fig 1 Snow crystal classification - Magono and Lee

(A) Power for melting, heating and evaporating impinging ice and/or water

(B) Convective heat loss to boundary layer

(A) \propto Water type, catch rate (R_w), temperature

$R_w \propto$ Collection efficiency (E), water concentration (LWC and/or IC), speed

$E \propto$ Particle size, geometry, air density (ρ_a) and speed

$\rho_a \propto$ Temperature, pressure

(B) \propto Geometry, temperature, air density, speed

Fig 2 Power requirements: thermal anti-icing system

Supercooled water

Classical icing condition
Freezing fog
Freezing rain

Ice

Ice crystal
Snow — precipitation
— recirculating

Mixed condition

Supercooled water and snow
or ice crystals

Fig 3 Breakdown into atmospheric types

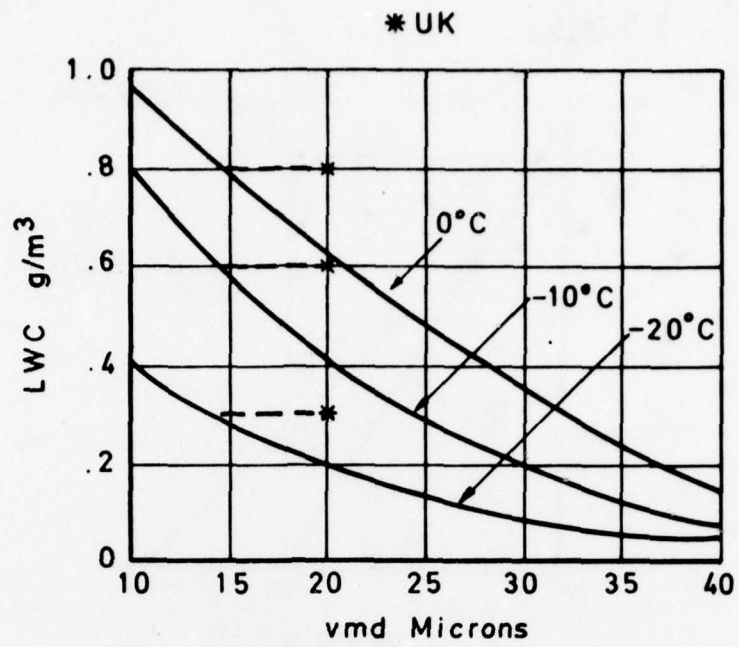

Fig 4 Continuous maximum

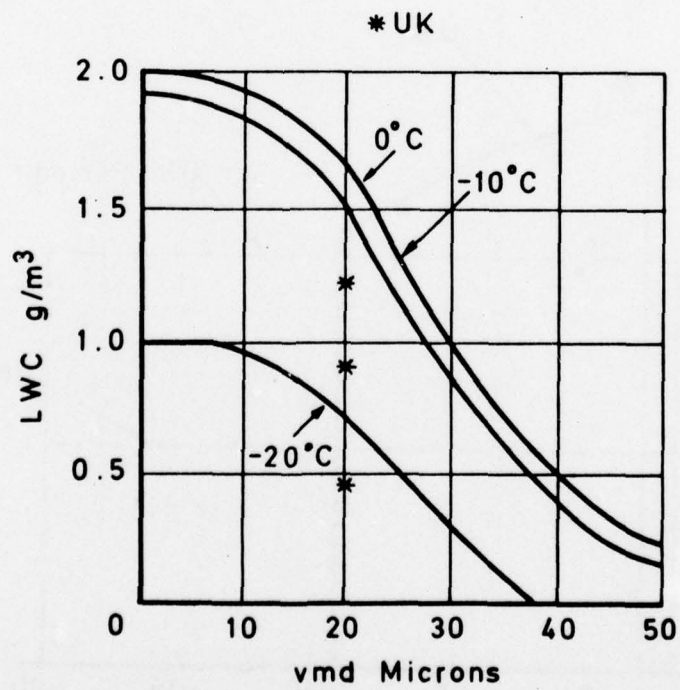

Fig 5 Intermittent maximum

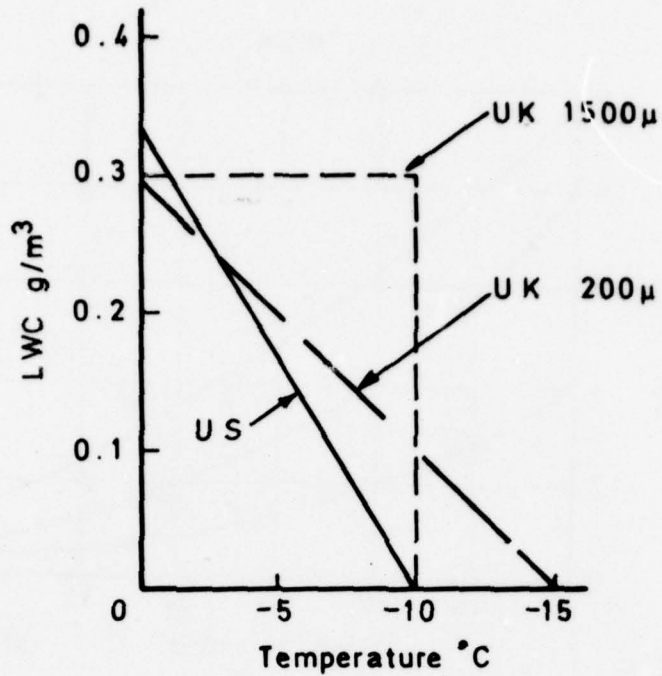

Fig 6 Freezing rain requirements

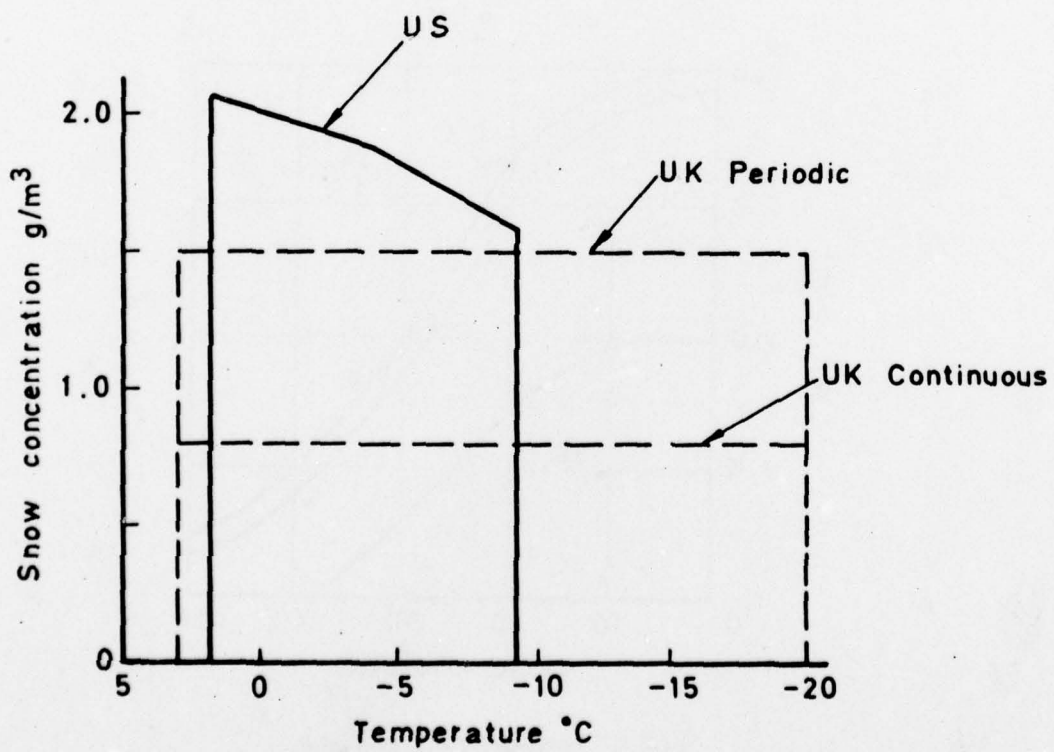
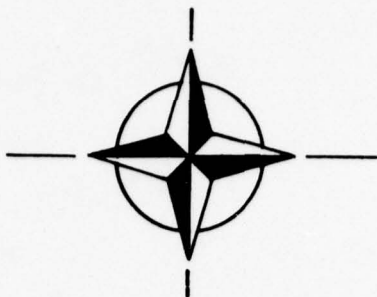

Fig 7 Snow requirements



NATO ARMY ARMAMENT GROUP

**PROBLEMS ASSOCIATED WITH FLIGHT
IN ATMOSPHERIC ICING CONDITIONS:
LIGHTNING, HAIL, GUSTS.**

BY

J.C.LECOUTRE and Ph. BOUGON

**AEROSPATIALE, HELICOPTER DIVISION,
MARIGNANE, FRANCE**

**SYMPOSIUM ON
HELICOPTER ICING**

6-7 November 1978

LONDON

PROBLEMS ASSOCIATED WITH FLIGHT IN ATMOSPHERIC ICING CONDITIONS : LIGHTNING, HAIL, GUSTS

INTRODUCTION

On April 25th. 1978, the SA 330 PUMA helicopter was granted its Certificate of Airworthiness authorizing flight in icing conditions without any limitation.

In the opinion of the French Authorities, responsible for certification, the authorization for flight in icing conditions lifts the last limitations imposed on rotorcraft operation, and they have deemed it necessary, to be in the operating conditions of fixed wing aircraft, to take into consideration the existence of weather conditions likely to be met more frequently or at a greater amplitude in these new possibilities of rotorcraft operation and which are not fully taken into account in FAR 29, that is :

- Hail
- Gusts
- Lightning

With a weather radar, it should be possible to avoid most of the critical flight conditions, but this is not sufficient to authorize I.F.R. flight without any limitation.

For this reason, the French Authorities have required that the PUMA should be protected against the disastrous effects of these three phenomena .

In this brief lecture, our intention is not to study in detail the weather phenomena but rather to sensitize the operators on the probabilities of meeting them and mention the specific protection systems which had to be provided on the PUMA for the icing flight clearance.

HAIL

Every one knows this phenomenon which starts at the top of only one cloud type, the cumulonimbus, and is due to the rapid freezing of large super-cooled water droplets. Then, hailstones are formed, they are compact and hard bodies of opaque or clear ice.

We have sufficient flight experience, particularly with the PUMA N^o 04, to confirm that going-through falling hailstones of small diameter, 3 to 4 mm. for instance, does not seriously damage the helicopter, in spite of their spectacular "machine-gunning" effect.

However, it is sure that conventional structures and particularly the transparent enclosures cannot withstand the high speed impact of larger hailstones, generally called "pigeon eggs"; having a diameter of 2 cm. and more, without going to the record-making hailstones, observed in 1822 in Bangalore and which had the size of a melon.

The manufacturers of weather radar for helicopters confirm that it is possible to detect satisfactorily the presence of hail clouds if the system is used properly.

In fact, these clouds form, on a radar scope, more or less characteristic images, such as those shown on Figure 1.

As it may be seen, these echoes, subject to interpretation, appear suddenly and along any edge of the storm. They may change in intensity and shape in a few seconds and therefore it is necessary to watch the scope carefully.

The various *Aerospatiale* flight crews, having participated in the icing trials run with the PUMA N° 4, are somewhat skeptical about these theoretical detections.

Therefore, the study of the aircraft behaviour under hailstone impact is essential.

Aerospatiale has undertaken a series of tests at the Centre d'Essais des Propulseurs in Saclay to study the behaviour of components deemed critical in the conditions recommended by the French Authorities, relevant rules being lacking (Figure 2).

| | |
|--------------------|---|
| Hailstone diameter | : 2.5 cm. (1 inch) |
| Density | : .8 / .9 |
| Distribution | : 20 hailstones per square meter (at the same time) |

The PUMA de-iced centre windshield, made of 2 semi-toughened glasspanes, each 3 mm. thick, has withstood, without damage, the impact of 8 hailstones at a speed of 127 m/sec. (457 km/h.).

Only one hailstone has gone through both panes at a speed of 170 m/sec. (612 km/h.) (Figure 3).

No damage has been noted on the other components tested and considered, at first, as critical :

- de-iced main blade leading edge under an impact at 230 m/sec.
- anti-iced tail rotor blade leading edge under an impact at 230 m/sec.
- perspex oil reservoir for lag dampers at 110 m/sec.
- vortex panel of engine air intake filter under an impact at 45 m/sec.

All these tests show that the "de-iced" PUMA is protected against the hail disastrous effects.

GUSTS

All the helicopter pilots have met severe or dangerous turbulent conditions.

These conditions may be divided into two basic types :

- a) clear weather turbulences
- b) turbulences associated with storms and precipitations.

The latter, the most severe, may be detected by a weather radar. (Figure 4).

On the radar scope, the image of a stormy precipitation shows various intensity levels corresponding to degrees of severity.

However, although no echo is received from the adjacent area (4), severe turbulences are to be expected there and most of the time they will be stronger than those corresponding to clear weather.

For this reason, the French Authorities have required, for this particular helicopter operation in icing conditions, that the rotorcraft could not be placed in a hazardous situation, not only in a vertical or horizontal gust of 30 ft/sec. as stated in FAR 29, but in a 66 ft/sec. gust as required in FAR 25.

Two separate studies have been made from the aircraft structural strength and dynamic response aspects.

From the calculations made at the most critical minimum weight and a speed of 260 km/hr. the following conclusions may be drawn :

STRUCTURAL STRENGTH

The 66 feet/second horizontal and vertical gusts are acceptable, in full confidence, if they are considered as ultimate loads, but are just acceptable as limit conditions.

DYNAMIC RESPONSE

In a vertical gust, the maximum variation in fore-and-aft attitude is 12° (peak-to-peak). The automatic pilot effect is small, it does not prevent reaching a maximum load factor of 2.7 for a gust lasting 1 second, but it reduces the attitude change to 8° only.

In a horizontal gust, the aircraft side-slips and there is a large change in lateral attitude of 55° (peak-to-peak) without automatic pilot in yaw and roll, but of 30° only with an automatic pilot.

LIGHTNING

Every one knows that the lightning electrical phenomenon usually accompanying the rain or hail storm generated in cumuliform clouds, develops a considerable energy of about 10 to 10 Joules, the current may range from 50 to 500 kA and the difference of potential may be 100 to 500 MV.

These values relative to "cloud-to-earth" discharges are well known.

On the contrary, we have little knowledge on discharges between clouds. Generally, it is thought that their values are lower.

To our knowledge, few helicopters have been struck by lightning in flight and this for the simple reason that there are practically no scheduled transport with this type of machine and pilots are flying carefully around probable stormy areas.

This would not be the case for truly "all weather" aircraft, flying I.M.C. and, for instance, ensuring the liaison with "off-shore" oil drilling platforms.

On a total of several millions of flying hours accumulated by the Aerospatiale helicopters, the only case known is a GAZELLE struck by lightning in North America in August 1976 in the following conditions :

Altitude : 2 000 feet,
at the edge of a stormy area
no precipitation.

The lightning bolt, after having gone through the "Fenestron" fin tip, has destroyed completely the plastic fin tip and the anti-collision light. (Figures 5 & 6).

At about the same time, investigations were conducted on GAZELLE at the "Centre d'Essais Aéronautiques" in Toulouse to determine the possible impact points, rotors turning.

A good correlation has been noted between simulation and reality. In fact, during our investigations, we have found that the fin was the point the most likely to be struck (3.6 MV wave 1.2/50 μ s). (Figure 7)

On the contrary, aeroplane manufacturers have a good experience of lightning strike in flight and many cases of airliners struck have been reported.

We will not study in detail, with respect to helicopters, the lightning strike probabilities according to the many parameters stated in the statistics, but we can extract the following information :

85 % of lightning strikes on aeroplanes occur in clouds,

85 % of lightning strikes on aeroplanes occur between sea level and 16 500 feet,

65 % of lightning strikes on aeroplanes occur between $- 5^{\circ}$ and $+ 5^{\circ}$ C.

In 70 % of cases, the lightning strikes occur in turbulent conditions considered as "light".

The frequency calculated over 1718 strikes reported on airliners is about one impact per 3 000 flying hours

All these figures may be used as a basis for helicopters.

However, as helicopters are flying always at an altitude where there is a high probability of lightning strike, it is necessary to increase the impact frequency.

As first estimation, it may be considered that an I.F.R. helicopter, used for scheduled transport, will be struck more or less severely once every 1 500 to 2 000 flying hours.

Taking this data into consideration, the French Authorities have required, for the PUMA icing certification, that the disastrous effects of lightning strikes be minimized. This objective has been achieved through many tests and the provision of specific equipment items related to the helicopter vital components likely to be damaged by a lightning strike.

1. DE-ICED MAIN ROTOR BLADE

These blades, made of composite materials, have a carbon skin and a titanium anti-erosion leading edge covering the heating mats.

They have been submitted to many tests : under voltage, at a peak voltage of 4 MV (wave 1.2/50 μ s) at the C.E.A.T. in Toulouse and under current in the Aerospatiale Central Laboratory with a TSS 8-6 standard wave (200 kA, 4C and 500 A - 500 C tail-off).

1.1. TESTS UNDER VOLTAGE

Through these tests, it has been possible to determine the preferential impact areas : tip fairing, blade outboard section at leading and trailing edge and trim tab. (Figure 8).

1.2. TESTS UNDER CURRENT

The impacts made at the discharge points, determined previously, have shown that the damage noted, although spectacular, remains localized and affects very little the structural and fatigue strengths of this type of material. (Figures 9 & 10).

In all cases, the lightning bolt follows the blade periphery either along the titanium leading edge or along the carbon skin without damaging the core of stressed sections.

2. ANTI-ICED TAIL ROTOR BLADE

Tests run under a maximum current of 170 kA. have shown that the solid metal spar integrity was maintained in all cases (Figure 11).

3. DE-ICING SYSTEM CYCLING AND CONTROL ELECTRONICS

During the first natural icing trial, two successive total failures were experienced on PUMA N° 04 when flying through clouds filled with fine ice crystals. It is to be noted that radio-communication and navigation equipment were strongly perturbed during these flights.

A series of tests run, at the C.E.A.T. in Toulouse, on a complete PUMA airframe equipped with all the main and tail rotor de-icing systems has shown that these failures were due to sudden atmospheric overvoltages (Figure 12).

The protection systems introduced at the blade roots and in the electronics have been substantiated by ground tests under voltage (4 MV. Wave : 1.2/50 μ s) and during the second natural icing trials when flying through clouds of the same nature.

Further, partial tests under current have demonstrated the excellent behaviour of heating mats on main blades struck under a current of 40 kA.

4. FUEL SYSTEM

In compliance with the F.A.A. recommendations, some modifications have been brought to the fuel system, which is a particularly critical item in case of lightning strike :

- Flame trap on fuel tank vents,
- Efficient ventilation of fuel tank bays,
- Replacement of all inspection doors made of composite material by metal panels,
- Installation of metal strips or metal spraying on additional fuel tanks made of laminates.

We feel we have thus minimized, on the PUMA, the disastrous effects of a lightning strike and given it a safety level at least as good, if not better, as that of equivalent de-iced aeroplanes. (Figure 13).

REFERENCES

TRAITE ELEMENTAIRE DE METEOROLOGIE by Alfred ANGOT

LIGHTNING PROTECTION OF AIRCRAFT by F.A.FISHER & J.A.PLUMER

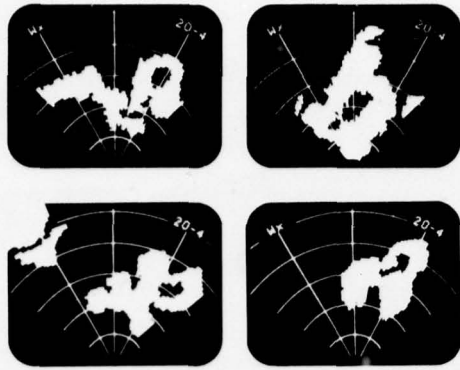

FIG. 1 :
HAIL ECHOES ON RADAR SCOPE

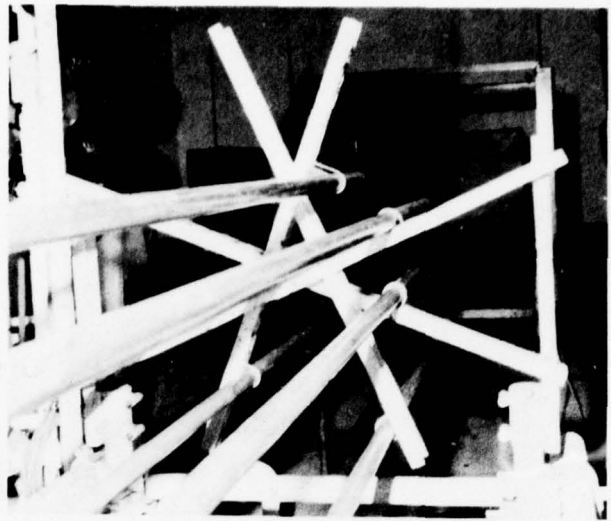

FIG. 2 : HAILSTONE TEST BENCH



FIG. 3 : HAILSTONE TEST
ON WINDSHIELD

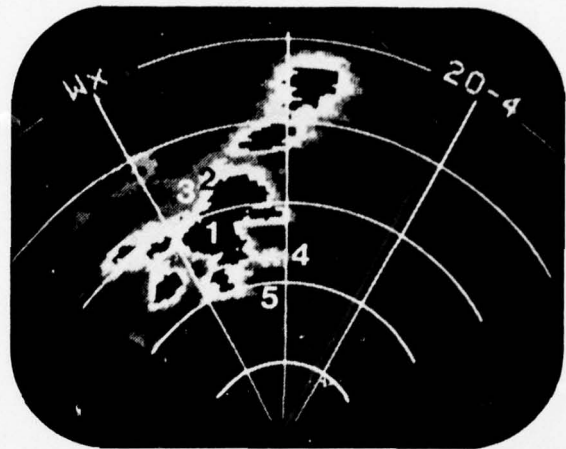

FIG. 4 :
TURBULENCE ECHO ON RADAR SCOPE



FIG. 5 : LIGHTNING STRIKE
ON GAZELLE FIN

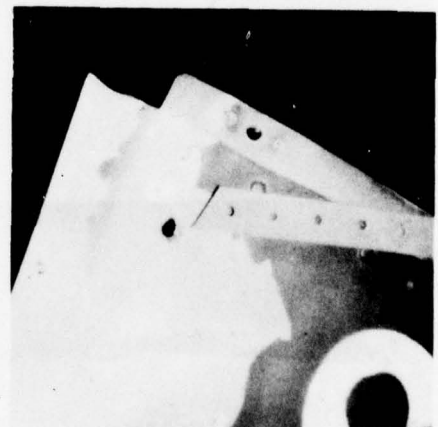

FIG. 6 : LIGHTNING STRIKE
ON GAZELLE FIN

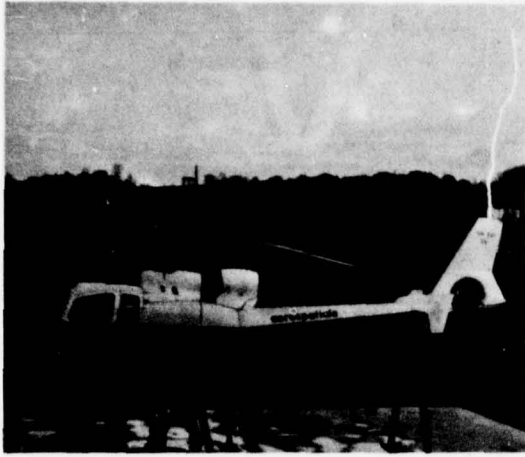

FIG. 7 :
LIGHTNING STRIKE TEST ON GAZELLE

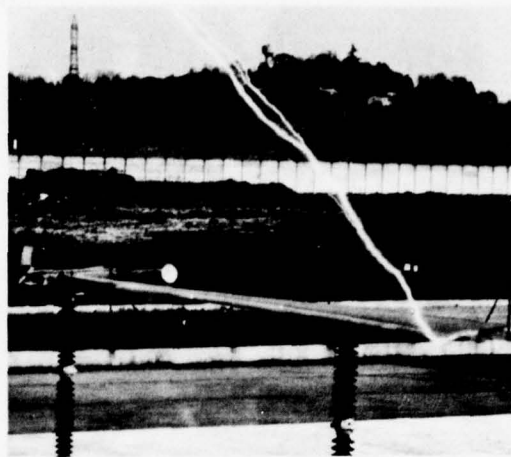

FIG. 8 : LIGHTNING STRIKE
TEST ON SA 330 MAIN BLADE

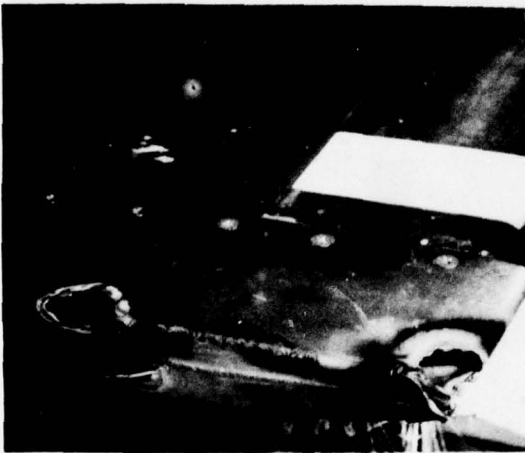

FIG. 9 : LIGHTNING STRIKE
CURRENT TEST ON SA 330 MAIN BLADE

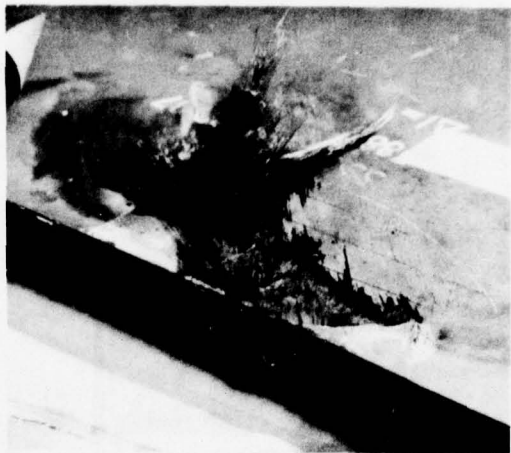

FIG. 10 : LIGHTNING STRIKE
CURRENT TEST ON SA 330 MAIN BLADE

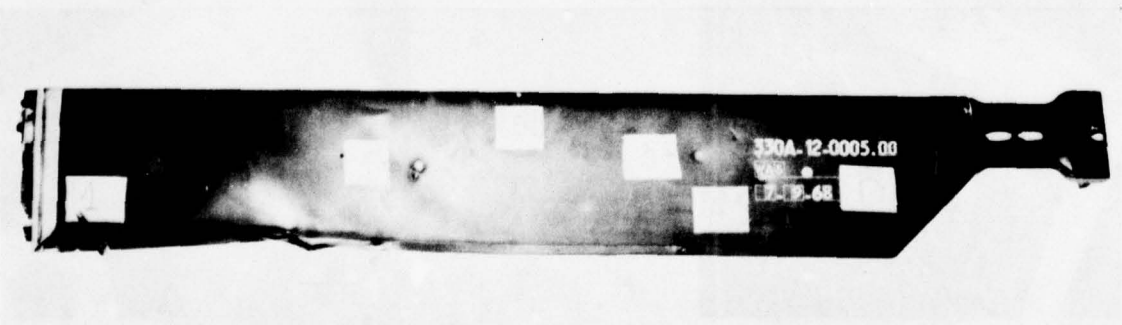

FIG. 11 : LIGHTNING STRIKE CURRENT TEST ON SA 330 REAR BLADE

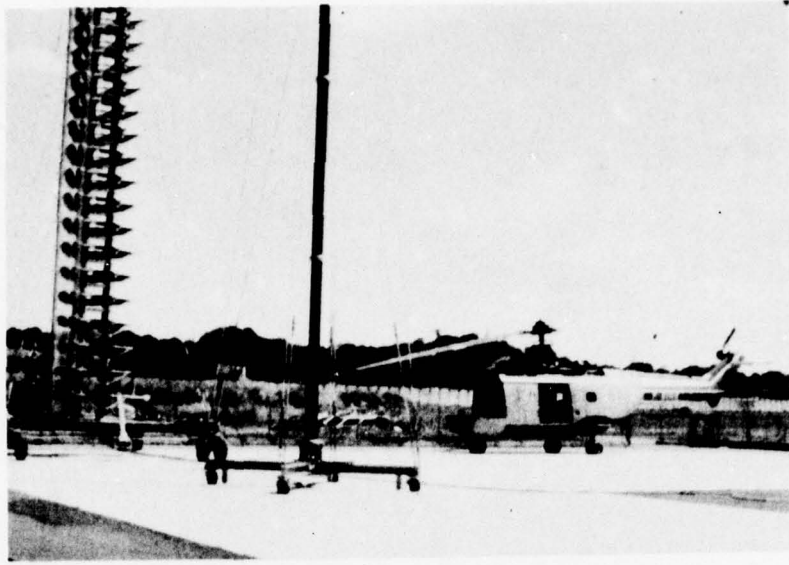

FIG. 12 : C.E.A.T. TEST BENCH IN TOULOUSE



FIG. 13 : GENERAL VIEW OF AIRCRAFT

PROBLEMES LIES AUX CONDITIONS DE VOL EN ATMOSPHERE GIVRANTE

GRELE
RAFALES
FOUDRE

INTRODUCTION

Le 25 avril 1978, l'hélicoptère SA 330 PUMA a reçu son certificat de navigabilité pour le vol en conditions givrantes sans aucune limitation.

Dans l'esprit des services officiels français qui ont accordé ce certificat, l'autorisation de vol en conditions d'atmosphère givrante, lève les dernières restrictions mises à l'utilisation des giravions, et il leur a paru nécessaire, pour se retrouver dans les conditions d'utilisation des avions, de tenir compte de l'existence de phénomènes météorologiques susceptibles d'être rencontrés à plus grande fréquence ou à plus grande amplitude dans ces nouvelles possibilités d'utilisation des giravions, et dont la F.A.R. 29 ne tient pas suffisamment compte, à savoir :

- Grêle
- Rafales
- Foudre

La présence d'un radar météo doit permettre d'éviter la plupart des cas de vol critique, mais n'est pas suffisante pour autoriser l'I.F.R. sans aucune restriction.

C'est pourquoi les Services Officiels français, pour cette certification, ont exigé que le PUMA soit protégé contre les effets catastrophiques de ces trois éléments.

Notre intention, dans ce bref exposé, n'est pas d'étudier dans le détail ces phénomènes météorologiques mais plutôt de sensibiliser l'utilisateur sur les probabilités de rencontre et de mentionner les protections spécifiques qui ont dû être montées sur le PUMA avec mention givrage.

GRELE

Tout le monde connaît ce phénomène qui est généré au sommet d'un seul type de nuage, le cumulo-nimbus, et dû à la congélation rapide de grosses gouttelettes d'eau en surfusion. Il se forme alors des grêlons constitués par des masses compactes et dures de glace opaque ou transparente.

Nous possédons suffisamment l'expérience en vol, notamment sur le PUMA N° 04, pour confirmer que la traversée d'une chute de grêlons de faible diamètre, 3 à 4 mm. par exemple, ne crée aucun endommagement sérieux sur hélicoptère, malgré le côté spectaculaire du "mitrillage" sur la structure.

Par contre, il est certain que les structures conventionnelles et notamment les verrières en plexiglas ne peuvent résister à l'impact à grande vitesse de grêlons de plus gros diamètre, communément appelés œufs de pigeon, de diamètre 2 cm. et plus, sans aller jusqu'au grêlon record observé à Bangalore en 1822 et qui avait la taille d'un melon.

Les constructeurs de radar météorologique pour hélicoptère confirment qu'il est possible de détecter de façon satisfaisante la présence de nuages de grêle si l'appareil est correctement utilisé.

Ces nuages, en effet, forment sur l'écran radar des images plus ou moins caractéristiques telles que celles représentées à la figure 1.

Ces échos, comme on le voit, sujets à interprétation, apparaissent de plus soudainement et le long de n'importe quel bord du contour de l'orage. Ils peuvent aussi changer d'intensité et de forme en quelques secondes et il est donc nécessaire de surveiller l'écran avec un soin extrême.

Ces détections théoriques de nuages de grêle ont laissé sceptiques les différents équipages de l'Aérospatiale qui ont assuré les campagnes de givrage sur le PUMA N° 04.

L'étude du comportement de l'appareil à l'impact de grêle s'avère donc indispensable.

L'Aérospatiale a entrepris un certain nombre d'essais au Centre d'Essais des Propulseurs à Saclay pour étudier le comportement d'éléments jugés critiques dans les conditions recommandées par les Services Officiels français en l'absence de réglemens. (Figure 2).

| | |
|-------------|--|
| ∅ grêlon | 2,5 cm. (1 pouce) |
| densité | 0,8 à 0,9 |
| répartition | 20 grêlons simultanément au m ² . |

La glace centrale dégivrée du PUMA, constituée de 2 feuilles de glaces semi-trempées de 3 mm. d'épaisseur chacune, a résisté sans dommage à l'impact de 8 grêlons sous une vitesse de 127 m/sec. (457 km/h).

Un seul grêlon a traversé les 2 glaces pour une vitesse de 170 m/sec. (612 km/h). (Figure 3).

Aucun endommagement n'a été constaté sur les autres éléments essayés jugés critiques a priori :

- bord d'attaque de pale principale dégivrée pour impact à V : 230 m/sec.
- bord d'attaque de pale arrière antigivrée pour impact à V : 230 m/sec.
- bol d'huile, en plexiglas, d'alimentation des amortisseurs de trainée à V : 110 m/sec.
- panneau Vortex d'alimentation des turbo-machines pour impact à V : 45 m/sec.

L'ensemble de ces essais montre que le PUMA dégivré est protégé contre les effets catastrophiques de la grêle.

RAFALES

Tous les pilotes d'hélicoptères ont rencontré de sévères ou dangereuses turbulences.

Ces turbulences peuvent être divisées en deux types de base :

- a) turbulences par temps clair
- b) turbulences associées aux orages et précipitations.

Ces dernières, les plus sévères, sont détectables à l'aide d'un radar météorologique (Figure 4).

L'image d'une précipitation orageuse sur un écran radar montre différents niveaux d'intensité correspondant à des degrés de sévérité de la turbulence.

Toutefois bien qu'aucun écho ne soit reçu de la zone adjacente (4), on doit s'attendre à de sévères turbulences dans cette zone, la plupart du temps supérieures à celles correspondant à un temps clair.

C'est pourquoi les Services Officiels français, pour cette utilisation particulière d'hélicoptères en conditions givrantes, ont exigé que le giravion ne puisse être mis en situation catastrophique, non plus sous une rafale verticale ou horizontale de 30 ft/sec. conformément à la F.A.R. mais sous une rafale de 66 ft/sec. par analogie avec la F.A.R. 25.

Deux études distinctes ont été menées sous les aspects résistance structurale et réponse dynamique de l'appareil.

Il ressort de ces calculs effectués à la masse minimale la plus critique et à la vitesse de 260 km/h. les conclusions suivantes :

RESISTANCE STRUCTURALE

Les rafales horizontales et verticales à 66 ft/sec. sont acceptables en toute certitude si on les considère comme charges ultimes, juste acceptables pour les conditions limites.

REPOSE DYNAMIQUE

Pour une rafale verticale, la variation maximale d'assiette longitudinale est de 12° (crête à crête). L'influence du pilote automatique est minime, elle n'empêche pas d'atteindre le facteur de charge maximum : 2,7 pour rafale d'une durée de 1 seconde, par contre elle atténue la variation d'assiette qui n'est plus que de 8° .

Pour une rafale horizontale, l'appareil prend un dérapage et une assiette latérale importants. Cette variation d'assiette est de 55° (crête à crête) sans pilote automatique de roulis-lacet et n'est plus que de 30° avec pilote automatique.

FOUDRE

Chacun sait que la manifestation électrique de la foudre accompagnant habituellement l'orage de pluie ou de grêle généré dans les nuages cumuliformes, met en jeu une énergie considérable de l'ordre de 10^{10} Joules, le courant pouvant être compris entre 50 et 500 kA. et la différence de potentiel entre 100 et 500 MV.

Ces valeurs qui concernent les décharges nuage-terre sont relativement bien connues.

Par contre, les décharges entre nuages sont pratiquement inconnues. On pense, généralement, qu'elles sont plus faibles.

A notre connaissance peu d'hélicoptères ont été foudroyés en vol pour la simple raison qu'il n'existe pratiquement pas de ligne aérienne régulière avec ce type de machines et que les pilotes contournent soigneusement les zones à forte probabilité orageuse.

Ce qui ne sera pas le cas pour de véritables appareils tout temps volant en I.M.C. et assurant, par exemple, les ravitaillements des plate-formes de forage en mer.

La seule expérience concrète de l'Aérospatiale sur un total de plusieurs millions d'heures de vol de l'ensemble de sa flotte hélicoptères porte sur une GAZELLE frappée par la foudre en Amérique du Nord en août 1976.

Altitude : 2 000 pieds
en bordure d'une zone orageuse
pas de précipitation.

L'arc, après avoir traversé le sommet de dérive du fenestron a détruit complètement le saumon en matière plastique et le feu anti-collision. (Figures 5 & 6).

A cette même époque, des recherches étaient entreprises sur GAZELLE au Centre d'Essais Aéronautiques de Toulouse pour déterminer les points d'impact possibles, rotors tournants.

Il est apparu une bonne corrélation entre la simulation et la réalité. En effet, au cours de l'investigation, nous avons constaté que cette même dérive était le point le plus susceptible d'être foudroyé (3,6 MV onde 1,2/50 μ s). (Figure 7).

Les constructeurs d'avions, par contre, ont une bonne expérience du foudroiement en vol et de nombreux cas de foudroiement d'avions de ligne ont été répertoriés.

Nous n'étudierons pas en détail, dans l'optique de l'hélicoptère, les possibilités de foudroiement en fonction de multiples paramètres, mentionnées dans les statistiques, mais nous pouvons en tirer les renseignements généraux suivants :

85 % des coups de foudre atteignent les avions dans les nuages,

85 % des coups de foudre atteignent les avions entre 0 et 16 500 pieds,

85 % des coups de foudre atteignent les avions entre - 5 et + 5° C .

Dans 70 % des cas, les coups de foudre ont été obtenus dans un régime turbulent qualifié de léger.

La fréquence calculée sur 1718 foudroiements observés sur avions de ligne est d'environ un impact pour 3 000 heures de vol.

Tous ces chiffres peuvent servir de base pour l'hélicoptère.

Toutefois, son plan de vol se situant toujours dans le niveau d'altitude à forte probabilité de foudroiement, il y a lieu d'augmenter la fréquence des impacts.

En première approximation, on peut considérer qu'un hélicoptère I.F.R. assurant un service régulier sera foudroyé avec plus ou moins de dommage toutes les 1 500 à 2 000 heures de vol.

Compte tenu de ces éléments, les Services Officiels français ont exigé, pour la certification en givrage du PUMA, que soient minimisés les effets catastrophiques de la foudre.

Cet objectif a été atteint avec un certain nombre d'essais ou équipements spécifiques intéressant les éléments vitaux de l'hélicoptère susceptibles d'être endommagés par la foudre.

1 - PALE PRINCIPALE DEGIVREE.

Pour mémoire, ces pales, en matériau composite, possèdent un revêtement carbone et un bord d'attaque anti-érosion en titane recouvrant les tapis chauffants.

Elles ont subi plusieurs séries d'essais en tension sur C.E.A.T. de Toulouse sous une tension crête de 4 MV. (onde 1,2/50 μ s) et en courant au Laboratoire Central de l'Aérospatiale avec une onde standard TSS8-6 (200 kA., 4 C et trainée 500 A, 500 C).

1 - 1. ESSAIS EN TENSION.

Ces essais ont permis de mettre en évidence les zones d'impact préférentielles : le saumon, l'extrémité de la pale côtés bord d'attaque et bord de fuite, le tab. (Figure 8).

1 - 2. ESSAIS EN COURANT.

Les tirs effectués aux points d'effluvage déterminés précédemment, ont mis en évidence que les détériorations observées, pour spectaculaires qu'elles soient, restent localisées et affectent peu les résistances structurales et en fatigue de ce type de matériau. (Figures 9 & 10).

L'arc chemine, dans tous les cas, sur la périphérie de la pale, soit par l'intermédiaire du bord d'attaque en titane, soit par l'intermédiaire du revêtement carbone, sans endommager le cœur même des parties travaillantes.

2 - PALE ARRIERE ANTIGIVREE.

Des essais en courant effectués sous des intensités maximales de 170 kA. ont montré que l'intégrité du longeron plein métallique était conservée dans tous les cas. (Figure 11).

3 - ELECTRONIQUE DE CYCLAGE ET DE COMMANDE DU DEGIVRAGE.

Lors de la première campagne en givrage naturel du PUMA N° 04, deux pannes totales successives sont intervenues lors de la traversée de nuages chargés de fins cristaux de glace. A noter que les moyens radio et radio-navigation étaient fortement parasités durant ces vols.

Une campagne d'essais effectuée au C.E.A.T. de Toulouse sur une structure complète de PUMA équipée de l'ensemble du dispositif de dégivrage des pales principales et arrières a mis en évidence que ces détériorations étaient dues aux brusques surtensions atmosphériques. (Figure 12).

Les systèmes de protection introduits au niveau de l'emplanture des pales et dans l'électronique ont été justifiés à la fois par essais en tension au sol (4 MV. onde 1,2/50 μ s) et durant la seconde campagne en givrage naturel lors des traversées de nuages de même nature.

Des essais partiels en courant ont montré, d'autre part, l'excellent comportement des tapis chauffants de pales principales foudroyés sous des intensités de 40 kA.

4 - CIRCUIT CARBURANT .

Conformément aux recommandations F.A.A., un certain nombre de modifications ont été apportées à l'ensemble du circuit carburant, particulièrement critique en cas de foudroiement:

- barrière anti-feu sur mises à l'air libre des réservoirs,
- ventilation efficace des compartiments réservoirs,
- remplacement de toutes les portes de visite en matériau composite par des portes métalliques,
- pose de bandes métalliques ou d'un schoopage métallique sur les réservoirs supplémentaires en stratifié.

Nous pensons ainsi avoir minimisé au maximum, sur le PUMA, les effets catastrophiques d'un foudroiement et apporter un degré de sécurité équivalent sinon supérieur à des avions dégivrés équivalents (Figure 13).

REFERENCES

TRAITE ELEMENTAIRE DE METEOROLOGIE par Alfred ANGOT,

LIGHTNING PROTECTION OF AIRCRAFT par F.A. FISHER et J.A. PLUMER.

Collection of Metereological Data in Icing Conditions
in the FRG Using Dornier Aircraft DO 28

W. Fuchs
Erprobungsstelle 61 d. Bw
D-8072 Manching, Germany

Discourse on occasion of the SYMPOSIUM ON HELICOPTER ICING
of NATO Panel X
6/7 November 1978 in London

1. Summary

For testing the de-icing system and demonstrating the airworthiness under moderate icing conditions an aircraft DO 28 has been instrumented to measure and store 17 meteorologically important atmospheric parameters.

The Geophysical Information Station makes arrangements for the flights in zones of anticipated icing, compares the test results with the forecasts and attempts to improve the methods of prediction. The test results revealed considerable differences between the predicted and the observed icing intensities.

During a minor number of test flights a helicopter BO 105 has been flying parallel to the DO 28 under nearly the same icing conditions thus permitting comparisons.

2. Preliminary Remarks

In autumn 1973 the Erprobungsstelle 61 d. Bw, the Flight Test Centre of the German Armed Forces, has been assigned the following task:

- Demonstration of the functional efficiency of the de-icing system for the aircraft DO 28 and
- demonstration of the airworthiness of the aircraft DO 28 under moderate natural icing conditions.

In January 1978 it was decided to equip a DO 28 with suitable meteorological instruments to measure the following parameters in supercooled clouds:

3. Parameters

- a) Air temperature
- b) Liquid water content
- c) Droplet size and distribution

The pilot expects an information on the icing severity in the flight weather forecast. Therefore are of further interest:

- d) The relation of the horizontal extension of a cloud to the icing zones contained in it as well as
- e) the rate of ice accretion.

For an optimum utilization of aircraft de-icing systems ice detectors are required which control the icing. Therefore, an information on the parameter is required:

- f) Icing severity

4. Meteorological Instruments

Table 1 shows the instruments available. For the parameters a) to f) the following instruments are installed :

| | |
|--|---|
| a) Air temperature : | REC 102 BV |
| b) Liquid water content : | - Backscatter probe of DFVLR - Ice warning detector NGL |
| c) Droplet size and distribution : | Droplet collector (oiled slide) |
| d) Extension of clouds : Humidity : | - Visual observation - Aluminium oxide humido- meter (ALOX-probe) |
| e) Ice accretion rate : | - HOT-ROD of Normalair Garrett - Ice warning detector (vibration frequency detector) REC IDS 3 |
| f) Degree of icing : | - REC IDS 3 - Ice warning detector NGL |

The figures 1 and 2 show the location of the instruments in the DO 28, figure 3 an example for the representation of the measured data.

5. Test Flights

Up to date 33 test flights have been carried through with the DO 28 and usable results may be expected from the analysis of these.

The test flights are carried through under the following conditions:

- a) Low stratus in the temperature range from -2° C to -10° C or
- b) Stratocumulus in the temperature range from $+1^{\circ}$ C to -12° C or
- c) Cumulus congestus with temperatures form -3° C to -12° C in the upper third of the clouds.

6. Analysis

Theoretical considerations and practical experiences revealed that the liquid water content of supercooled clouds is particularly and strongly influencing the icing intensity. Therefore, one objective of the analysis is to verify that liquid water content and icing intensity are actually proportional. This is assumed, for example, for the ice warning detector-NGL, used for measuring the liquid water content and (with a different scale) the severity of icing. One of the best examples of the analysis shows figure 4: it shows three diagrams of the flight on 18 March 1975. The measurements were made in the altitude range from 1001 to 2000 meters and in the three temperature ranges from $-4,0$ to $-6,0^{\circ}$ C, $-6,1$ to $-8,0^{\circ}$ C and $-8,1$ to $-10,0^{\circ}$ C. On the x-axis the time interval between two ice warning signals (of the REC IDS 3) in seconds is plotted to the right. On the y-axis the liquid water content in grams/meters³ as measured by means of an ice warning detector NGL is plotted (see figure 3 again).

From figure 4 can be clearly seen that the supercooled liquid

water content is inversely proportional to the time interval between two ice warning signals; or accordingly:

the liquid water content is proportional to the icing intensity.

This type of analysis is continued with improvements to investigate further statistical relations, because the whole computer printout does not only contain the three diagrams shown in figure 4 but also 20 diagrams for four altitude ranges up to 4000 meters and five temperature ranges from 0 to -10° C. For example, an investigation is made whether the icing intensity depends upon the air temperature and the liquid water content at the altitude.

7. Considerations to Improve the Forecast

No information on the liquid water content is available to the aeronautical forecaster. Furthermore, the test flights revealed that the liquid water content varied considerably in "metereological fields" in which the synoptic metereology assumes homogeneous conditions. Therefore, there must be factors influencing locally the liquid water content and thus also icing. The influence of the geographical relief as well as the precipitation demonstrates the flight of 23 March 1978.

7.1. Metereological Situation

An occluding frontal system crossed Germany with a WSW upper air flow. Precipitations caused by upslope fell at ground temperatures from $+1$ to $+5^{\circ}$ C partially as rain, partially as snow.

The band of precipitation was in this case located between the boundary line Stettin - Oder - Prague - Passau - Alps in the east and the boundary line west coast of Denmark - Hamburg - Kassel - Upper Rhine - Lake of Geneva in the west (see figure 5).

7.2 Description of Flight

The Flight of the DO 28 (see figures 6 and 7) started at 08:12 z at EDSI. It led via Straubing (08:32 z) to Hemau (08:52 z) and back again via Straubing (09:05 z) to EDSI (09:32 z), thus achieving that the same flight path was observed at different times.

7.3 Results

The usual forecast methods resultet in "minor to moderate" icing in the frontal area. Contrary to this, the flight revealed that the prevailing icing conditions were in no way homogeneous.

Considering the stow and lee areas (see figures 6 and 7) it was possible to explain the phenomena in one flight direction (to Hemau): increase of icing to Straubing, decrease at Hemau. Stow means lifting and condensation of aqueous vapour to droplets; lee means subsidence and evaporation. On the return path, however, the same phenomena in a reversed order could not be observed (see figure 7). Considering the formation of precipitations it was possible to explain these, too; if precipitation is formed during the snow phase, the crystals grow at the expense of the droplets due to the difference in the saturation vapour pressure, thus reducing the icing intensity.

From this two new problems are resulting:

- how strongly is the stow effect compensated by the formation of precipitation and
- how great is the risk by high snow concentration?

The latter was verified by the BO 105, flying in FL 90 on 23 March 78 at the same time (see figure 8), which

had to discontinue its flight from Straubing to EDSI because of engine failure at position X in figure 6 at 08:53 z.

8. Final Remarks

A further flight analysis shall show whether and how strong other factors, such as

- curvature of flow
- vorticity advection and
- instability,

locally and temporally change the liquid water content in a meteorological field. Finally, future test flights shall be extended to cover areas with other climatic conditions than those encountered in the Alpine foothills, for example the coasts of the North Sea and of Norway.

| NO | PARAMETER | INSTRUMENT | RECORDING | REPRESENTATION (FIGURE 3) |
|----|-------------------------------------|-----------------------------------|----------------|---------------------------------------|
| 1 | AIRCRAFT ALTITUDE | AIRBORNE SYSTEM | MAGNETIC TAPE | ☐ PRESSURE ALTITUDE Z (KM) |
| 2 | AIRSPEED | AIRBORNE SYSTEM | MAGNETIC TAPE | ⊙ AIRSPEED V (KM/H) |
| 3 | TEMPERATURE | REC 102 BV | MAGNETIC TAPE | Δ TEMPERATURE TS (GRD C) |
| 4 | LIQUID WATER CONTENT | ICE WARNING DETECTOR NGL (1) | MAGNETIC TAPE | + LIQUID WATER CONTENT (6 / LBM) |
| 5 | VISIBILITY | BACKSCATTER PROBE DFVLR | MAGNETIC TAPE | ◇ VISIBILITY S (M) |
| 6 | DEW POINT | ALOX-PROBE DFVLR | MAGNETIC TAPE | |
| 7 | CLOUD EXTENT | SWITCH | MAGNETIC TAPE | |
| 8 | ICING INTENSITY | ICE WARNING DETECTOR NGL (2) | MAGNETIC TAPE | ⊕ ICING INTENSITY |
| 9 | ICING INTENSITY | ICE WARNING DETECTOR REC IDS 3 | MAGNETIC TAPE | ⊗ |
| 10 | ICE ACCRETION RATE | ICE WARNING DETECTOR REC IDS 3 | MAGNETIC TAPE | |
| 11 | ICE DETECTOR SIGNAL | ICE WARNING DETECTOR REC IDS 3 | MAGNETIC TAPE | |
| 12 | CLOUD CAMERA RELEASE SIGNAL | MINIATURE CAMERA | MAGNETIC TAPE | |
| 13 | TIME | TIME CODE GEN. | MAGNETIC TAPE | |
| 14 | INTERCOMMUNICATION | AIRBORNE SYSTEM | MAGNETIC TAPE | |
| 15 | EXPOSITION TIME OF OILED SLIDE | OILED SLIDE | MAGNETIC TAPE | |
| 16 | LIQUID WATER CONTENT OILED SLIDE | OILED SLIDE | MINIATURE FILM | |
| 17 | DROPLET SEIZE | OILED SLIDE | MINIATURE FILM | |

TABLE 1 : LIST OF PARAMETERS AND INSTRUMENTS

Figure 1: Locatin of the instruments in the DO 28.

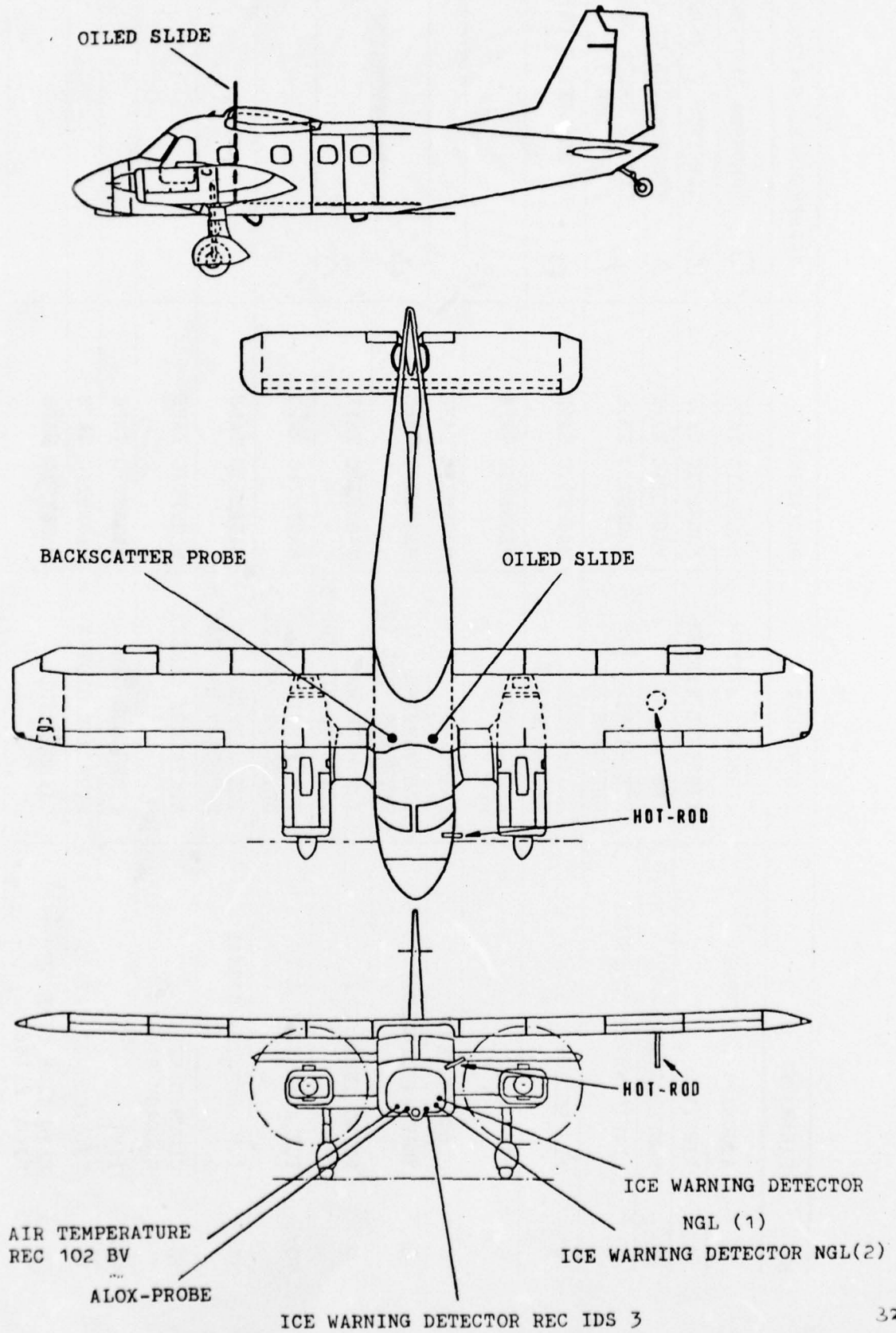

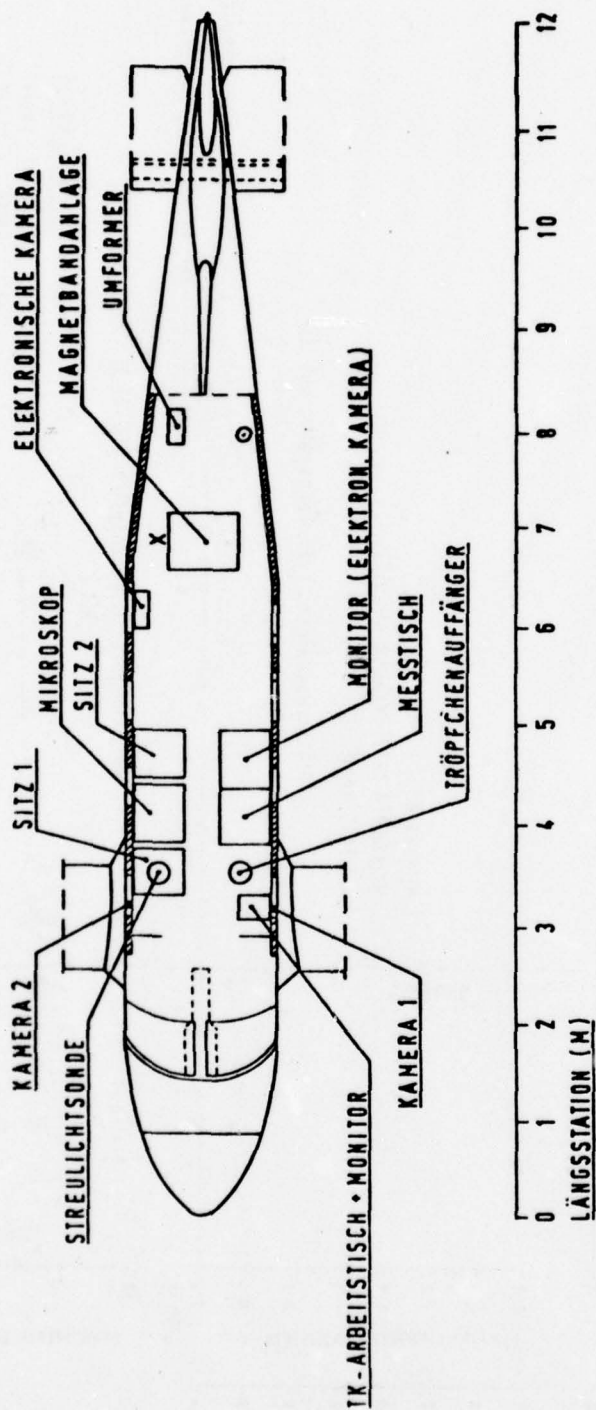

Figure 2: Location of the instruments in the DO 28.

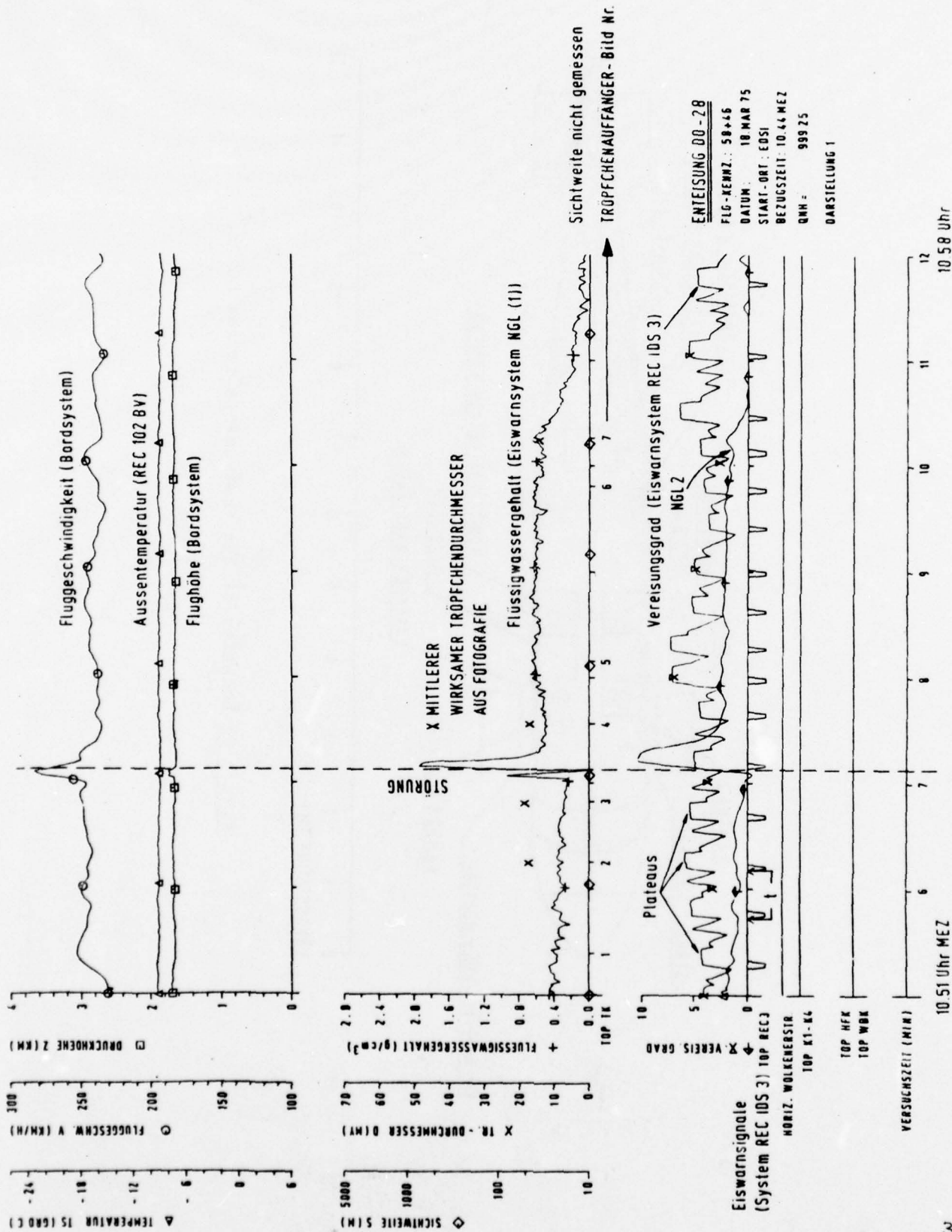

Figure 3: Representation of the measured data 18 March 1975.

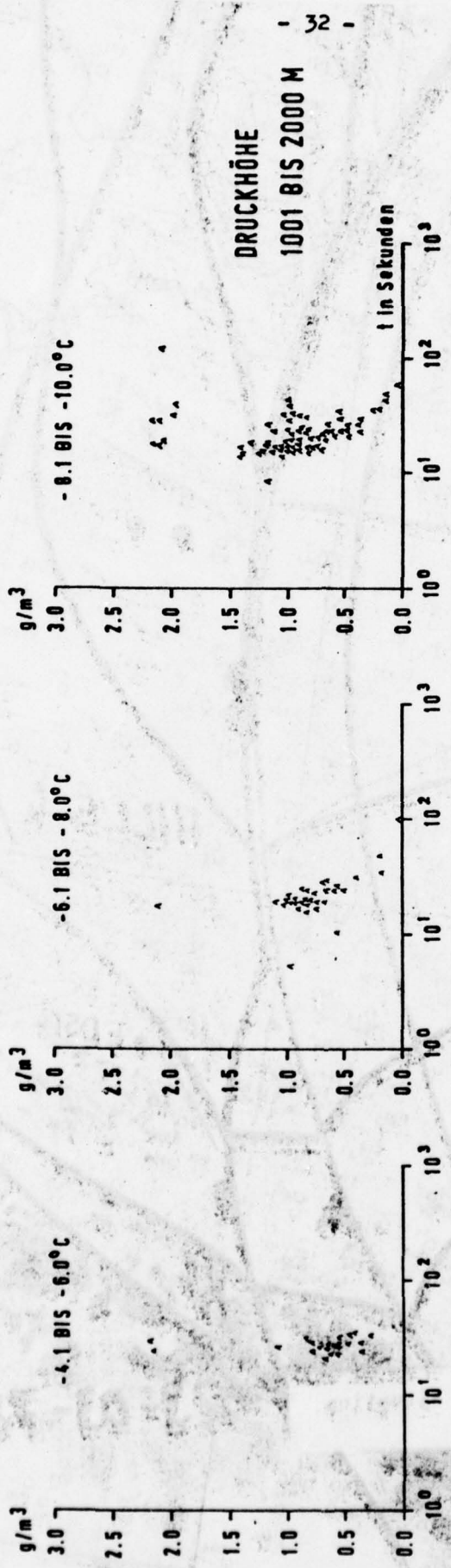

Figure 4: Flight F 24, 18 March 1975. X-axis: Time interval between two ice warning signals (of the REC IDS 3) in seconds. Y-axis: Liquid water content in Grams/cbm.

Projektion
Nord-Breite

300 km 400 km 500 km

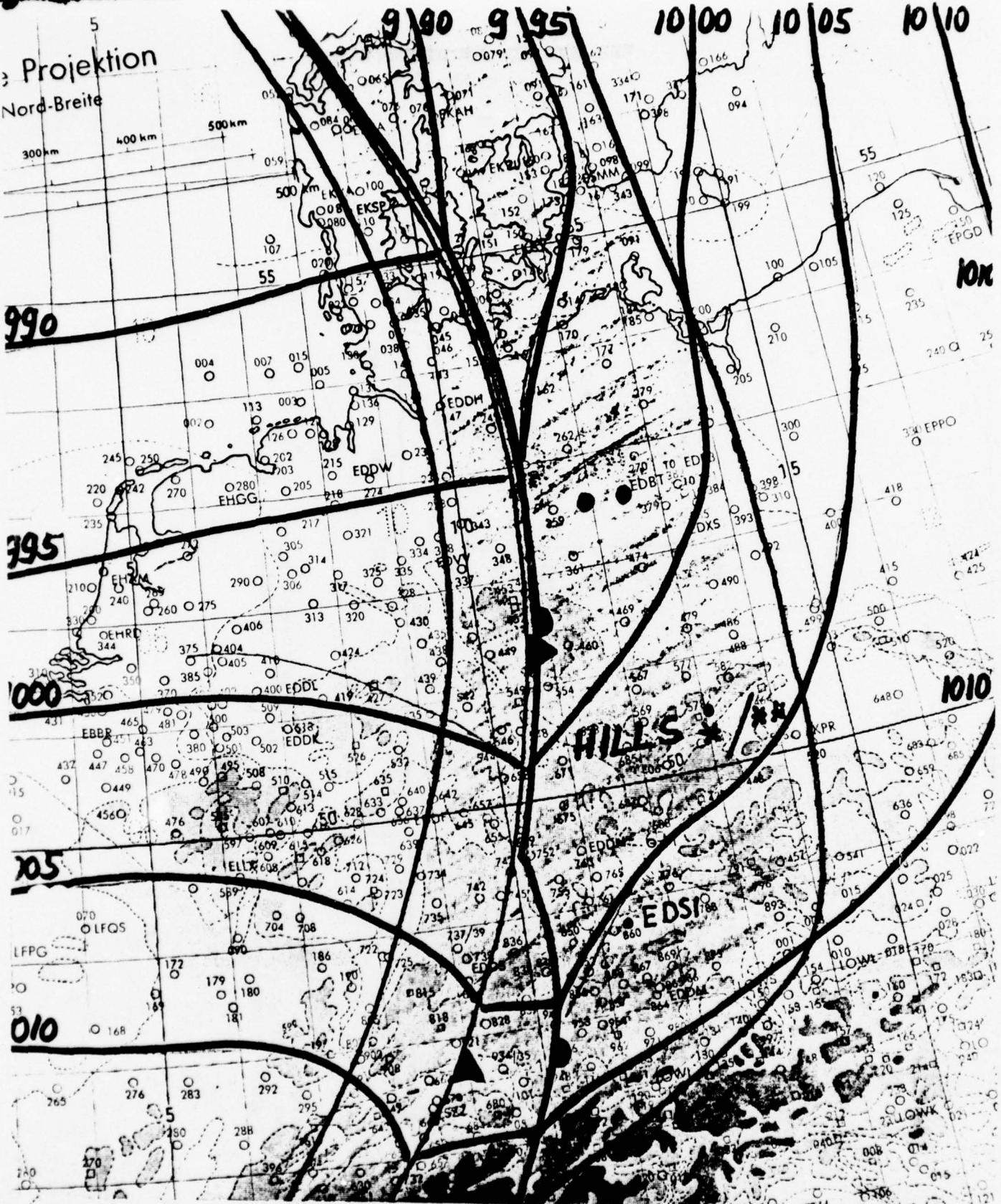

Figure 5: Meteorological situation

23-03-78 09Z



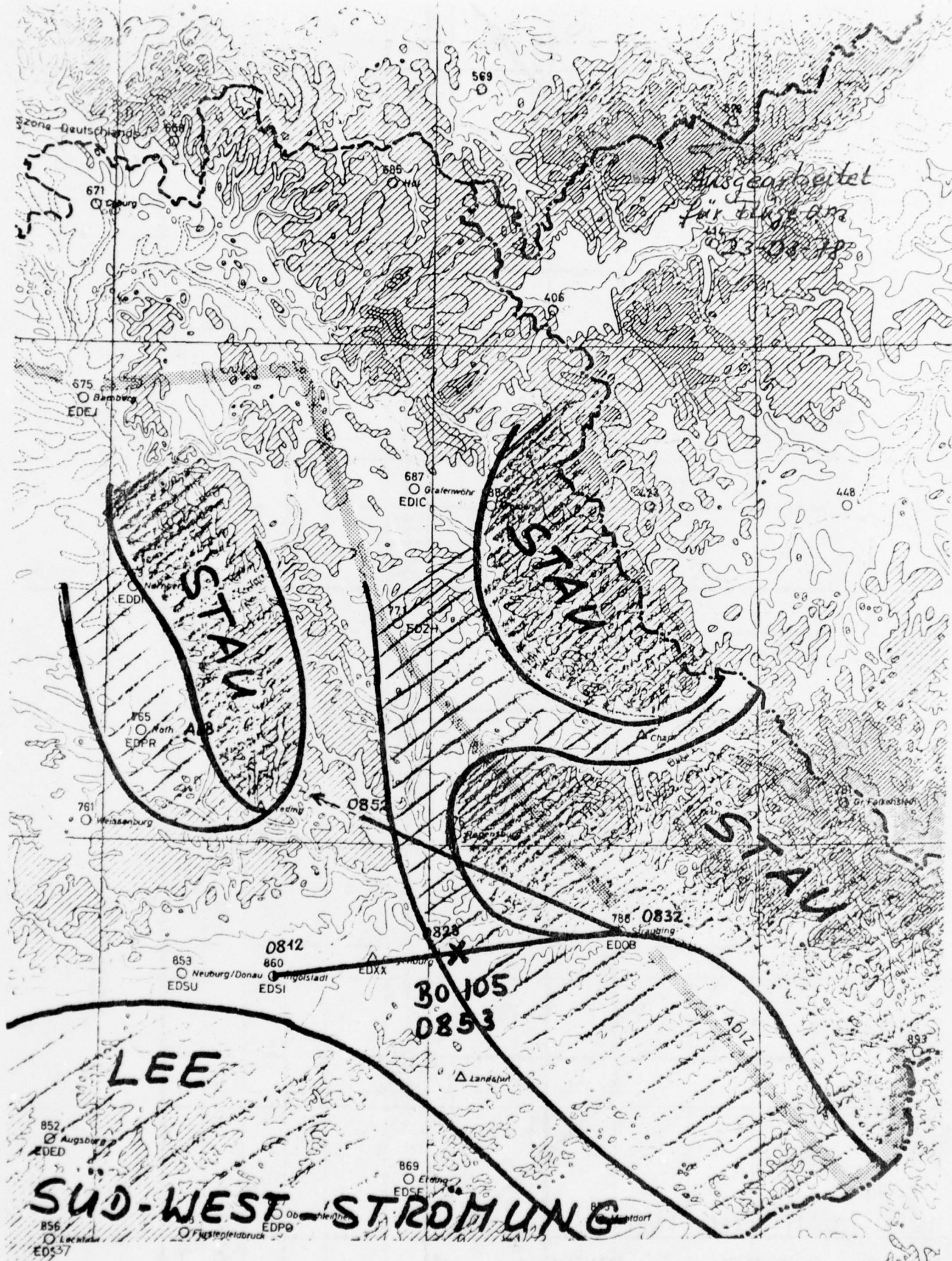

Figure 6: Stow (upslope)- and lee (downslope)- areas during SW-ly airflow.

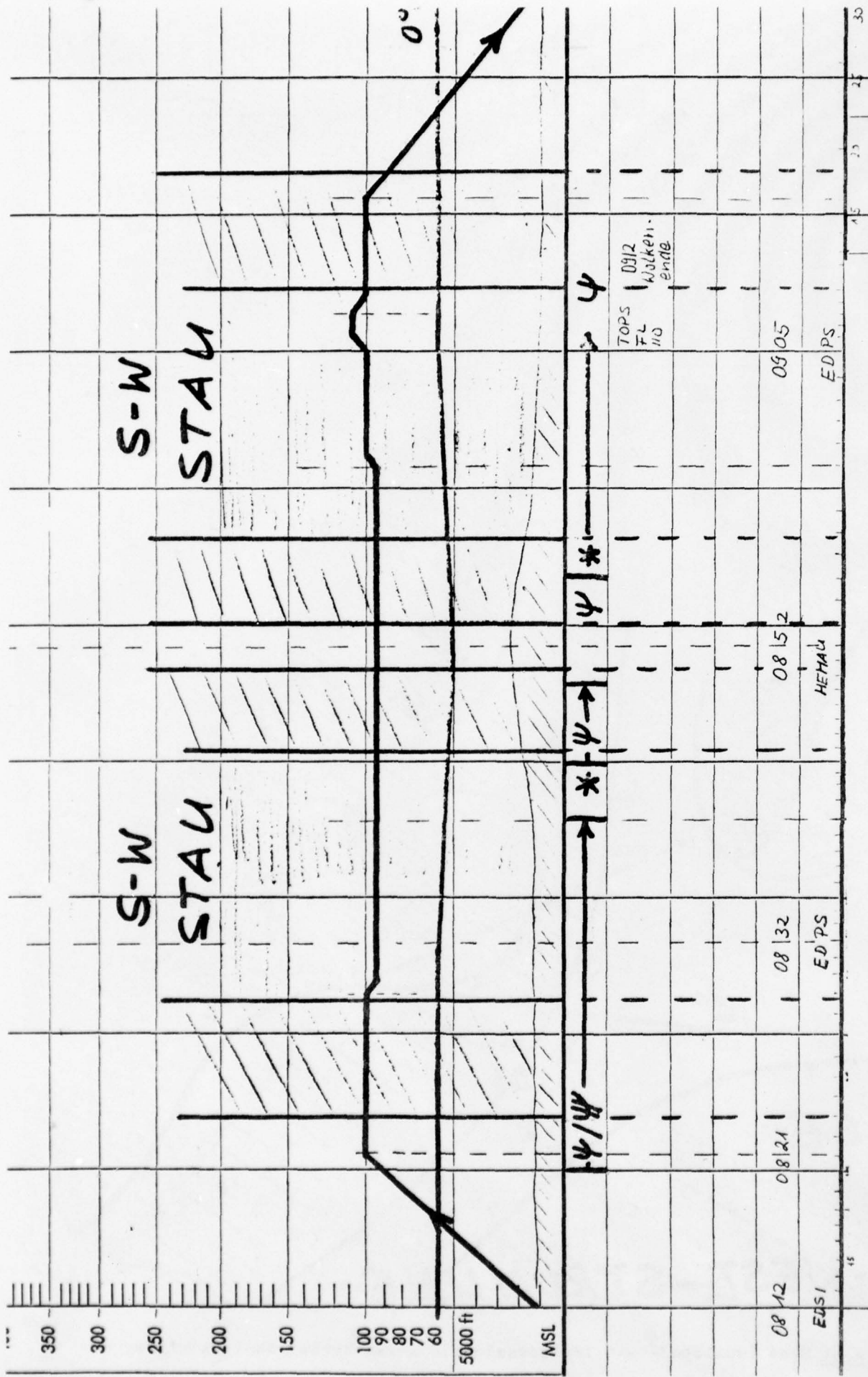

Figure 7: Flight cross section of D0 28 flight 23 March 1978.

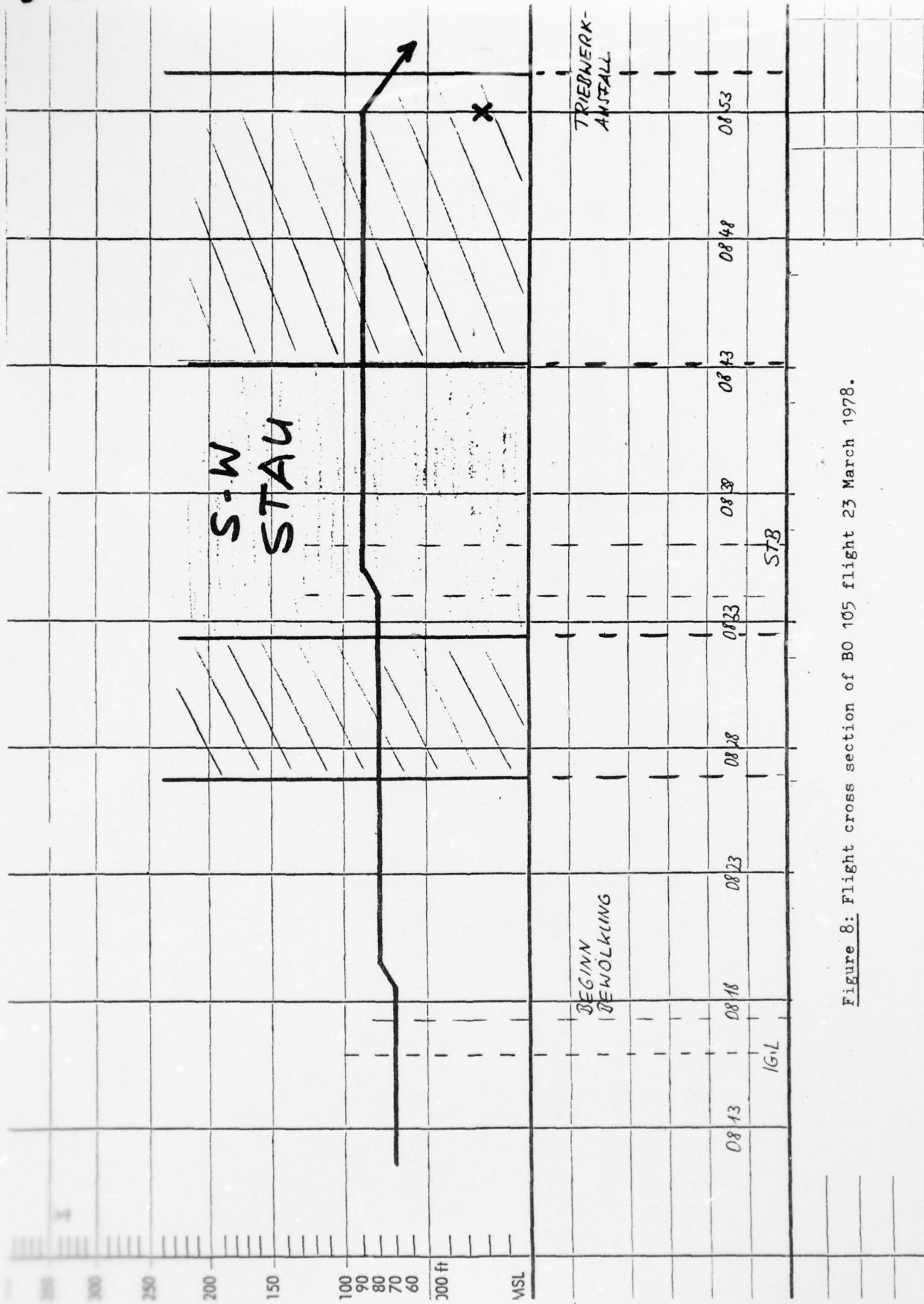

Figure 8: Flight cross section of BO 105 flight 23 March 1978.

ICING INSTRUMENTATION

J D Booker & G F Barlow

Royal Aircraft Establishment
Engineering Physics Department
FARNBOROUGH Hants UK

SUMMARY

During helicopter icing flight trials the atmospheric conditions should be closely monitored, particularly the outside air temperature, cloud liquid water content, cloud particle size spectrum and concentration of ice particles. This paper reviews the instruments that are currently available and under development to measure these parameters.

1 INTRODUCTION

In the last decade British experience of helicopter icing flight trials, undertaken for the purpose of giving icing flight clearance to specific helicopters, has shown the need for comprehensive definition of the environment during such trials. McNaughtan¹ has identified the important parameters which need to be determined: outside air temperature (OAT), cloud liquid water content (LWC), cloud droplet size spectrum and ice particle concentration. This paper considers some flight instruments now available or under development, and relates RAE experience of them in icing tunnel assessments and their use in certification flight trials undertaken by the Aeroplane and Armament Experimental Establishment (A&AEE). Instrumentation used to examine the effects of icing on the trials helicopters is described in the paper by Ray².

There are several interlocking aims in obtaining such data. It is expected that it will be possible to relate helicopter performance in icing to the prevailing atmospheric conditions. In particular, the degradation of performance due to rotor ice accretion should be understandable, given these data and improved theoretical treatment^{3,4}. To date, many of the performance changes such as rapid rotor torque rise have been inexplicable. It will also be possible to ensure that the certification trials have been conducted over the full range of meteorological conditions laid down in the requirements. It may even be shown that the specification of the conditions is unrealistic, since data are very limited. However, the gathering of meteorological statistics needs to be undertaken separately from clearance flight trials, although similar instrumentation will be required. The data will also be required to control the ice protection system, for example heater-on time and cycle time; or, if the helicopter is unprotected, to indicate to the pilot that he is approaching unacceptable conditions. Not all the instruments will be required, or would be practical,

for operational use; in particular, the droplet size spectrum analyser is far too bulky and costly except for trials work.

Some of these parameters, for example OAT and LWC, have been measured previously on fixed wing aircraft, but it was quickly learnt that there are some special problems to be overcome in using the instruments on helicopters. For example, the very much lower speed range, including even the hover; the changing flow direction; the high vibrational levels; and the need for rapid response. At first instrumentation was given too little attention in the British effort to carry out flight trials and many troubles were experienced, not least with the reliability of sensors and recorders. Repair was difficult miles away from Britain. Even when instruments were working, the data produced were conflicting and unsatisfactory. The situation is now much improved, and considerable effort is now being expended in Britain to assess instruments thoroughly in icing tunnels, to give them initial flight trials near home, even if there are no icing conditions, and to ensure proper mounting in the trials aircraft.

2 MEASUREMENT OF AIR TEMPERATURE

For flight in potential icing conditions it is essential to know the outside air temperature with accuracy over the low temperature operating range of a helicopter. In unprotected helicopters it will often be the decisive factor in deciding whether to enter cloud, whilst in protected helicopters the de-icing system is controlled in part by reference to OAT, since this has a critical influence on the manner in which the ice builds up. Through icing trials experience A&AEE have suggested that an accuracy of $\pm 1^{\circ}\text{C}$ is essential and $\pm \frac{1}{2}^{\circ}\text{C}$ is desirable.

When an air temperature sensing probe is exposed to icing conditions ice accretes on the sensing element and modifies the indicated temperature significantly. For fixed wing aircraft, total temperature probes with inertial separation of droplets have been employed to overcome this problem. During early helicopter icing trials A&AEE evaluated a number of OAT measuring techniques and found shielded resistance element probes to be the most successful. The shield is shaped to remove atmospheric free water by inertial separation before the air comes into contact with the sensing element.

Three types of instrument using this principle have been employed on British icing trials. They are:

- i An A&AEE designed wire wound nickel resistance sensor with Tinsley IDJ 300 digital temperature display. (Fig 1).
- ii Rosemount Type E22001 reverse flow platinum resistance sensor with digital temperature display. (Fig 2).
- iii Normalair Garrett Type 0701 037 011 OAT indicator system having reverse flow platinum resistance sensor and moving coil dial indicator. (Fig 3).

The Tinsley and Rosemount digital cockpit displays cover the whole operating temperature range of the aircraft from tropical to arctic in increments of 0.1°C , a reading accuracy not possible with a dial instrument. The Normalair Garrett covers a range restricted to $+10^{\circ}\text{C}$ to -20°C to improve the reading

accuracy of its 50 mm diameter dial, and therefore an additional instrument is needed for temperatures outside this range. (An option of $+50^{\circ}\text{C}$ to -40°C is offered if a reduced reading accuracy of the dial is acceptable.) All three instruments have a separate output for recording.

3 MEASUREMENT OF CLOUD LIQUID WATER CONTENT (LWC)

The LWC of a cloud is the mass of liquid water that is present in a given volume of air, usually measured in grammes per cubic metre. The LWC directly controls the rate of ice accretion and is probably the most important parameter to be measured in an icing cloud. There are two basic types of LWC measuring instrument: the accretion type and the thermal or inferential type.

3.1 Accretion LWC Instruments

The accretion technique is to simply allow ice to accrete on a probe and to measure the rate of accretion by some suitable means. The LWC is derived from this rate of growth and a knowledge of the airspeed over the probe. The accretion method is the simplest but does have the limitation that at high LWC and high (sub-zero) temperatures the latent heat that is released as the water freezes raises the temperature sufficiently to prevent all the impinging water from freezing. Operating above this so-called 'Ludlam Limit', with a freezing fraction of less than unity, will mean that the accretion instrument will underestimate the LWC, (Fig 4). Cooling the probe will help to raise the Ludlam Limit but care must be taken to not extract water vapour from the air. In any case, if a reasonable thickness of ice is allowed to accrete, the poor thermal conductivity of ice will prevent probe cooling being effective. It is apparent that the accretion probe has to be de-iced and this is usually carried out thermally when a pre-determined amount of ice has formed. Readings cannot be taken during the de-ice period and the subsequent cool-down period, collectively known as the instrument 'dead-time', and therefore these must be kept to a minimum.

The simplest probe, and probably the most widely used, is the accretion rod such as the NGL 'hot-rod' (Fig 5), an aerofoil shaped blade that projects from the side of the aircraft so that the pilot can view it. Pilots' estimations of the accretion thickness have been used for many years to infer the LWC of icing clouds. The hot-rod can be de-iced by manually switching on electrical heating elements incorporated in the probe.

To improve the accuracy of reading of the ice thickness A&AEE devised the vernier accretion meter (VAM) (Fig 6). The VAM consists of two blades set at an angle to one another. The trailing edge of the leading blade is used as a vernier scale to measure the thickness of the ice accreting on the leading edge of the trailing blade. This device has been used in several UK helicopter trials.

A more sophisticated system has also been developed by A&AEE. This is the TV-Raster accretion meter in which a TV camera views the rod against a dark background, (Fig 7). Counting the TV lines of white ice against the dark background enables an accurate measurement, with automatic recording, to be made of the accretion thickness.

Another accretion instrument is the RAE rotating disc LWC meter. An earlier version of this instrument was used successfully from fixed wing aircraft

20 years ago, but it was found to be unsuitable for helicopter use in its original form for two main reasons. Lack of mast rigidity in unsteady airflows resulted in spurious movement in the ice measuring linkage; and ice gradually accumulated between the mechanical follower and the rim of the disc at some temperatures. Both produced false LWC readings. An improved version was produced by RAE in cooperation with A&AEE and Lucas Aerospace Ltd, who suggested the use of air gauging to eliminate the mechanical problems. In this instrument a thin disc of 50 mm diameter is mounted at the extremity of a heated strut exposed to the airstream, (Fig 8). The disc rotates at 7 rpm and ice accretes on its forward face. As the disc rotates the ice accreted on the rim passes beneath an air gauging jet, (Fig 9), which senses its thickness before it is removed by a scraper. The process is continuous. The LWC is derived from the measured ice thickness, rotational speed of the disc and velocity of the airstream. The high catch efficiency of the thin disc makes the instrument sensitive and it is effective at temperatures near 0°C since the disc remains cool because it is not thermally de-iced. The instrument was used successfully by WHL in the Wessex heated rotor blade trial in Denmark in 1977/78 where its rapid and continuous indication of changes in LWC was valuable in helping the crew to position the aircraft in the severe conditions needed for the trial.

The dynamic ice detector developed by the National Research Council in Ottawa is an accretion instrument, the development of which was described by Ringer and Stallabrass at the AGARD Conference in April this year (see Ref 5). The instrument is being further developed and marketed under licence by Leigh Instruments Ltd of Canada. It has an annular ejector (Fig 10) which induces the ambient air over a small flat-fronted probe. Ice accreting on the probe occludes the light passing between a photo-emitting diode and a photo-transistor. The ramp signal generated as ice thickness increases is used to operate an ice warning and to trigger the probe de-icing. The rate of ramp rise can be used to determine LWC. Alternative displays and rate meters are available, all drawing their information from the ice detector unit (IDU) ramp signal. An icing severity meter (ISM) measures the time taken to accrete 0.2 mm of ice on the probe to calculate LWC. The digital display of LWC is updated at the end of every ramp.

Several IDU/ISM sets (Fig 11) were bought by RAE in late 1976. They have been extensively tested and calibrated in icing tunnels and found to have a fast response to changes in LWC and a short dead-time. They have been used during icing trials on UK helicopters during the past two winters and will be used again this coming winter. An IDU/ISM pair was the prime source of LWC data during the 1977/78 heated rotor blade trial in Denmark. During US Army trials an IDU has provided data to a Leigh integrating rate unit (IRU). LWC for each ramp is displayed but the IRU also sums the accretion from successive ramps until a pre-set total accretion limit is reached. A main rotor blade de-ice signal is then generated. The design of the IDU head has been altered recently to improve the instrument performance at temperatures close to 0°C and one of these units will be flown during the 1978/79 UK heated rotor blade trial.

Another instrument developed specifically for helicopters is the Rosemount 871FF1 Aspirated Ice Detector and 512AE1 Icing Rate Indicator (Fig 12), which is to be fitted to the UH-60A helicopter. This instrument has been developed from un aspirated ratemeters used on fixed wing aircraft. RAE evaluated several marks of the fixed wing IDS series in icing tunnels and British helicopter icing trials and they were found to have a rapid response and to give reasonable results at airspeeds above 100 kn, although the proportion of dead time became

significant at the higher speeds and LWCs. In the 871FF1 an aspirator operated by engine bleed air draws the ambient air over a small cylindrical probe at approximately constant velocity. The probe vibrates ultrasonically and when ice forms on its surface there is a change of frequency. The rate of change of frequency is detected and processed electronically to represent LWC. When the mass of ice reaches a predetermined value the probe is de-iced thermally and, after cooling, accretion starts again. During the de-icing cycle the output signal is held at the level obtaining just prior to de-icing. The cockpit installation consists of an ice warning light, an indicator dial showing LWC from 0 to 2.0 g/m³ and an LWC output which may be used to control a de-icing system or for recording purposes. For trials work it is also possible to obtain a supplementary check on the mean LWC by recording and counting the probe de-icing pulses.

The prototype instrument designated 871FF was flown on the UH-1H icing trial during winter 1977/78 and subsequently calibrated in the NRC icing tunnel. The calibration revealed a number of teething problems which RAE understands have been overcome in the production instruments. RAE and A&AEE intend to evaluate the production instrument in the Lucas Aerospace Artington icing tunnel and in flight trials in Canada during the coming winter.

3.2 Thermal LWC Instruments

Thermal or inferential LWC measuring instruments utilise a heated probe or wire, exposed to the airflow, that is either maintained at constant temperature or has a constant heating power applied. The power required, or the temperature achieved, can be used to derive the LWC if the convection cooling of the airflow can be allowed for. The difficulties with these instruments arise when correcting for this 'dry' cooling, which depends on air temperature, density and velocity at the probe.

The best known thermal LWC instrument is the Johnson-Williams device (Fig 13). This uses a heated wire at right angles to the direction of airflow and another reference wire parallel to the flow. Few drops impinge on the parallel wire, so this provides the measure of the convective cooling, but in turbulent flow inaccuracies can arise. The J-W has been used widely over many years, primarily in fixed-wing aircraft. It does under-estimate LWC when droplets much larger than 100 μ diameter are present. A J-W will be flown next year on an RAE helicopter, to measure LWC during trials to measure blade temperatures.

The NGL (formerly Teddington) LWC instrument uses two heated cylinders. One is exposed to the cloud and the other is exposed to air from which the cloud particles have been inertially separated. The difference in the power required to maintain the two cylinders at constant temperature is used as a measure of LWC. This instrument has been used successfully on fixed-wing aircraft but is rather too sensitive to changes in airflow direction for helicopter use.

RAE has a contract with the Atmospheric Physics Research Group at the University of Manchester Institute of Science and Technology (UMIST) to develop a constant temperature hot wire instrument for helicopter use, based on the work of Merceret and Schricker⁶ at the National Hurricane Research Laboratory (NHRL) in Miami. The sensing wire will be situated in a constant velocity duct and atmospheric temperature variation will be allowed for by maintaining the wire at a level of 50°C above ambient. The power required to do this is a measure of the LWC. The prototype instrument is due to be completed in April 1979.

A thermal instrument that should not have the problem of providing the reference 'dry' power required is currently being developed by Cambridge Consultants Ltd under contract for the RAE. This will have a single heated probe which is maintained at constant temperature. The power required to overcome the convective cooling will be calculated from measured air velocity, temperature and density data. Additional power will be due to evaporation of impinging droplets and will be used to compute the LWC. The accuracy of the air data must be high if a reasonable LWC resolution is to be achieved. The probe will have a high droplet catch efficiency and be relatively insensitive to pitch and yaw.

3.3 Other Methods

A third technique for measuring LWC is the evaporative total water probe developed by Ruskin. Free ice and/or water is evaporated in a heater and the humidity of the sample measured. The humidity of the air before the evaporator is also measured to calculate free water content. The difficulty is one of measuring the humidity with sufficient accuracy since at 0°C a 1 degree change in dew point is equivalent to approximately a 0.5 g/m³ change in water content. Errors are also possible due to the difficulties of aerodynamically separating the free water from the air to obtain the reference air sample.

Two other techniques are being investigated by the Dept of Physics at UMIST in collaboration with RAE. One is the feasibility of adopting for helicopter use a forward scattering device for the measurement of LWC designed at UMIST⁷. The other is the possibility that a simplified version of the Keily Probe⁸ may be appropriate for the airborne measurement of liquid water content. These two developments are at the moment in their early stages.

4 PARTICLE SIZING

Although helicopter icing trials have been carried out for many years, few serious attempts have been made to measure the droplet size spectrum of the clouds that have been encountered. Size spectra or volume mean diameters (vmd) are laid down in the design specifications and it is suggested that more effort has gone into showing that test facilities produce the 'specification cloud' than in measuring the actual spectra encountered in helicopter flight trials. Measuring these spectra will show (a) how much real clouds differ from the specification cloud and (b) whether this matters to the helicopter. It can be shown that in theory an increase in droplet vmd can produce an increase in catch efficiency that is highly significant on a rotor blade but hardly noticeable on an accretion rod. Changes in vmd may account for some of the rapid performance changes in helicopters in icing conditions.

The oil-coated slide has been used for many years to measure droplet diameters. The slide is exposed briefly to the airflow and is then photographed. Droplets captured by the oil are then counted into size groups from the photographs. Whilst this method is still useful as a basic check on particle sizes, it does not lend itself easily to in-flight use and the number of particles it is practical to count is often statistically very small. Only limited use has been made of this technique in helicopter icing flights, for example during BO 105 icing trials⁹.

Other techniques such as the Formvar replicator have been used in cloud physics investigations to derive size and phase information on cloud particles. Mylar tape coated with a solution of Formvar plastic and chloroform is exposed to the cloud and then dried. The encapsulated particles evaporate leaving behind

plastic replicas which can be later sized and counted. The analysis of such data is laborious and is, to some extent, subjective. This technique has not, as far as is known, been used in helicopter icing trials.

The instruments that have been used widely for cloud particle sizing are those developed by Knollenberg^{10,11} and marketed by Particle Measuring Systems Inc. Real time measurements of droplet size can be made and these can be used to compute LWC. PMS instruments have been used in a limited number of flight trials directly related to icing (see Ref 12) but probably more often as a check on the size of particles being generated in ground icing facilities. The General Electric Company¹³ use them in their outdoor ground test facility and NGTE, Pyestock¹⁴ use them during icing trials in their Cell 3 West.

The particle sizes of interest mean that two PMS probes are required. Droplets in the 3 to 45 μm range are counted by the Forward Scattering Spectrometer Probe (FSSP-100) (Fig 14) or by the earlier Axially Scattering Spectrometer Probe (ASSP-100). These instruments measure the light scattered by a particle as it passes through a laser beam. The resultant signal is a function of the particle diameter and is used to generate a count in one of the fifteen 3 μm wide size channels. Particles from 30 to 300 μm diameter are measured by one of the PMS Optical Array Probes, the OAP-200X (Fig 15). Particles passing through a laser beam cast shadows on a linear array of photodiodes. The number of diodes that are shadowed determines which of the fifteen 20 μm wide size channels a particle is counted into. An FSSP-100 and an OAP-200X have been acquired by RAE Farnborough this year and will shortly be flown on a helicopter to measure cloud droplet spectra, prior to their use during icing certification trials.

5 DETECTION OF ICE PARTICLES

When a helicopter is flying in cloud it is difficult to know if it is actually in a mixture of water and ice particles. Such 'mixed conditions' may be due to the cloud glaciating or, and more likely under icing conditions, to snow falling through the cloud from a higher cloud. It has become important to know whether the aircraft is in mixed conditions, since it has been suggested that the presence of ice has, by changing the accretion characteristics on the rotor blade, caused the rapid torque rises that have occurred during some flights. Ideally one would like to know what ratio of ice to water is present and size of the ice particles. Up to now, probably the best that has been achieved is that the crew have seen relatively large snowflakes passing in front of a dark background, such as a tyre.

A Formvar replicator can be used to record the presence of ice crystals but large crystals will be shattered on impact and, as has already been stated, the analysis of the data is slow. A more sophisticated method of recording a picture of the particles is that of using the two-dimensional spectrometer probes that have been developed by Knollenberg¹¹. As the shadow of the particle passes across a linear array of photodiodes a series of images are recorded at regular intervals. A two-dimensional picture of the particle can then be reconstructed and ice particles can be readily identified. The disadvantage of this method is that large amounts of data can be rapidly accumulated and the data analysis is fairly time consuming. Although a fine tool for the cloud physicist it is probably not suited to helicopter icing trials.

There are other instruments that detect ice particles by using the birefringent property of ice. The plane of polarisation of polarised light is rotated by ice but not by water and this provides the means of phase discrimination. Turner and Radke¹⁵ at the University of Washington have developed an ice particle counter (UW-IPC) which detects the depolarised signal in the forward scattered light. The detection efficiency is size-dependent with particles having to be as large as 250 μm before they are all seen. The Mee Industries ice particle counter (Mee-IPC) detects light scattered at 90° and it has been suggested (see Ref 16) that the detection of the depolarised light due to the birefringence of ice is of secondary importance when compared with the detection of reflected light from the external faces of the ice crystals. Knollenberg has incorporated polarising optics and detection circuits into his optical array probes to discriminate between ice and water. Only 20 to 30% of the ice particles seen by an instrument are identified as ice, due to the fact that only favourable crystal orientations will allow light transmission and hence rotation of the plane of polarisation. Current instruments therefore provide a means of detecting and counting at least some percentage of the ice particles. None gives absolute discrimination over the whole particle size range and large non-spherical rain drops may be identified as ice. The UW-IPC and the Mee-IPC detect a greater percentage of the large crystals than small ones although Knollenberg has stated that detection is not strongly size dependent.

A relatively simple ice discriminator is being developed by RAE Farnborough which will not attempt to count the ice particles but only indicate the presence of ice. The instrument has been tested in a wind tunnel and in natural snowfall. Two units are being manufactured for flight trials this winter. The light source is a projector lamp (Fig 16) the light from which is collimated and passed through a polarising filter before crossing the sampling duct. Light that has been depolarised passes through the second polarising filter, set at 90° to the first, before being focussed onto the photo detector. A filter eliminates the IR that would otherwise pass through both the polarisers and swamp the detector output. In the first units the detector output will simply trigger a warning signal that is held on for a preset time.

6 IN-SERVICE INSTRUMENTATION

The instrumentation that will be required on a helicopter cleared to fly in icing will depend on the flight clearance given and on the control inputs needed by the protection system. Any clearance limits imposed may in turn be affected by the response and accuracy of the available instruments.

An aircraft that has a clearance limited in terms of LWC and/or OAT will need these parameters displayed to the pilot to enable him to stay within his clearance. This assumes that he will know how to escape from a situation just within the limits without passing through an area where conditions are worse.

A helicopter that has an unlimited icing clearance need have no additional display of atmospheric parameters available to the pilot. Instruments such as an OAT sensor and a simple ice detector (not a LWC meter) will suffice to activate the protection system.

Further control inputs may be required by the protection system with, for example, OAT controlling blade heater 'on-time' and LWC controlling heater 'off-time'. To provide the latter input a LWC measuring instrument with an integrating rate unit may be required.

In addition to the actual operational need it is suggested that, because of the shortage of statistical data on icing conditions at low levels mentioned by McNaughtan¹, all helicopters flying in icing should initially carry OAT and LWC measuring instruments with their outputs recorded automatically. In this way vital information could be collected during routine service flying.

ACKNOWLEDGEMENT

The authors would like to thank the following for providing some of the illustrations in this paper: Rosemount Engineering Company Ltd for Fig 12, and A&AEE, Boscombe Down, for Figs 1, 5, 6 and 7.

REFERENCES

- 1 I I McNaughtan. Atmospheric conditions for helicopter icing protection design. Paper presented at NATO Panel X AC 225 Symposium. London 1978.
- 2 G V Ray. Techniques for icing test flying. Paper presented at NATO Panel X AC 225 Symposium. London 1978.
- 3 J T Cansdale & I I McNaughtan. Calculation of surface temperature and ice accretion rate in a mixed water droplet/ice crystal cloud. RAE Technical Report 77090, June 1977.
- 4 J R Stallabrass & E P Lozowski. Ice Shapes on cylinders and rotor blades. Paper presented at NATO Panel X AC 225 Symposium. London 1978.
- 5 T R Ringer & J R Stallabrass. The dynamic ice detector for helicopters. AGARD PEP 51 (A) Meeting, April 1978. AGARD-CP-236, Aug 1978.
- 6 F J Merceret & T L Schricker. A new hot-wire liquid cloud water meter. J Appl. Meteor. Vol 14, No 3, 1975.
- 7 A M I Chittenden. UMIST. Unpublished work.
- 8 R C Corbin, J Latham, C S Mill & I M Stromberg. An assessment of the Kelly probe for the ground-based measurement of drop size distributions in clouds. Quart. J R Met Soc. Vol 104 No 441.
- 9 D Bender. Tests under snow and icing conditions with the BO 105 engine installation. AGARD PEP 51(A) Meeting, April 1978. AGARD-CP-236, Aug 1978.
- 10 R G Knollenberg. The Optical Array: an alternative to scattering or extinction for airborne particle size determination. J Appl. Meteor. Vol 9, No 1, 1970.
- 11 R G Knollenberg. Three new instruments for cloud physics measurements: the 2-D spectrometer, the forward scattering spectrometer probe, and the active scattering aerosol spectrometer. American Meteorological Society. International Cloud Physics Conference, July 1976.
- 12 J F Gayet and R G Soulage. Structure microphysique des nuages givrants. AGARD PEP 51(A) Meeting, April 1978. AGARD-CP-236, Aug 1978.
- 13 R G Keller. Measurement and control of simulated environmental icing conditions in an outdoor, free jet, engine ground test facility. AGARD PEP 51(A) Meeting, April 1978. AGARD-CP-236, Aug 1978.
- 14 R D Swift. Icing test facilities at the National Gas Turbine Establishment. AGARD PEP 51(A) Meeting, April 1978. AGARD-CP-236, Aug 1978.
- 15 F M Turner & L F Radke. The design and evaluation of an airborne optical ice particle counter. J Appl. Meteor. Vol 12, No 8, 1973.
- 16 F M Turner, L F Radke and P V Hobbs. Optical techniques for counting ice particles in mixed-phase clouds. Atmospheric Technology. No 8 Spring 1976.

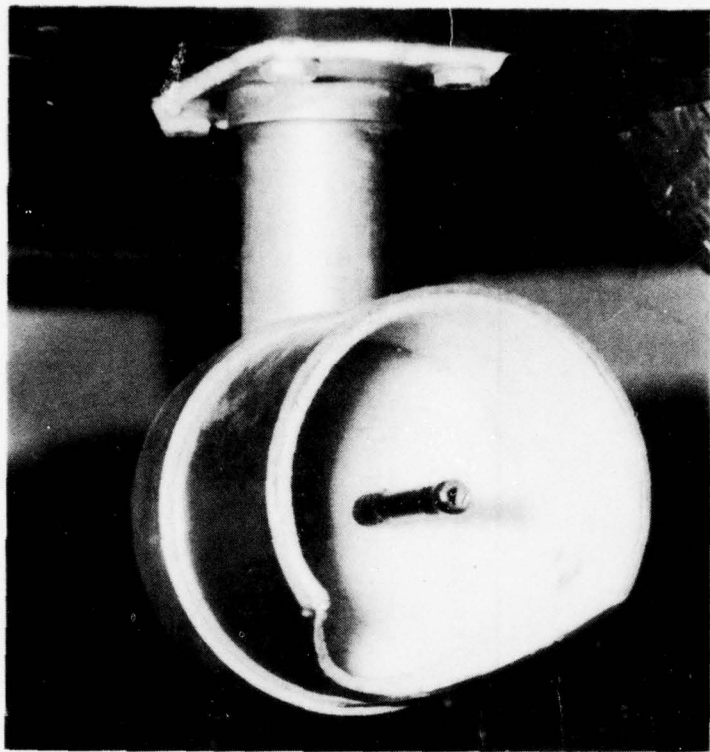

Fig 1 A&AEE oat sensing head

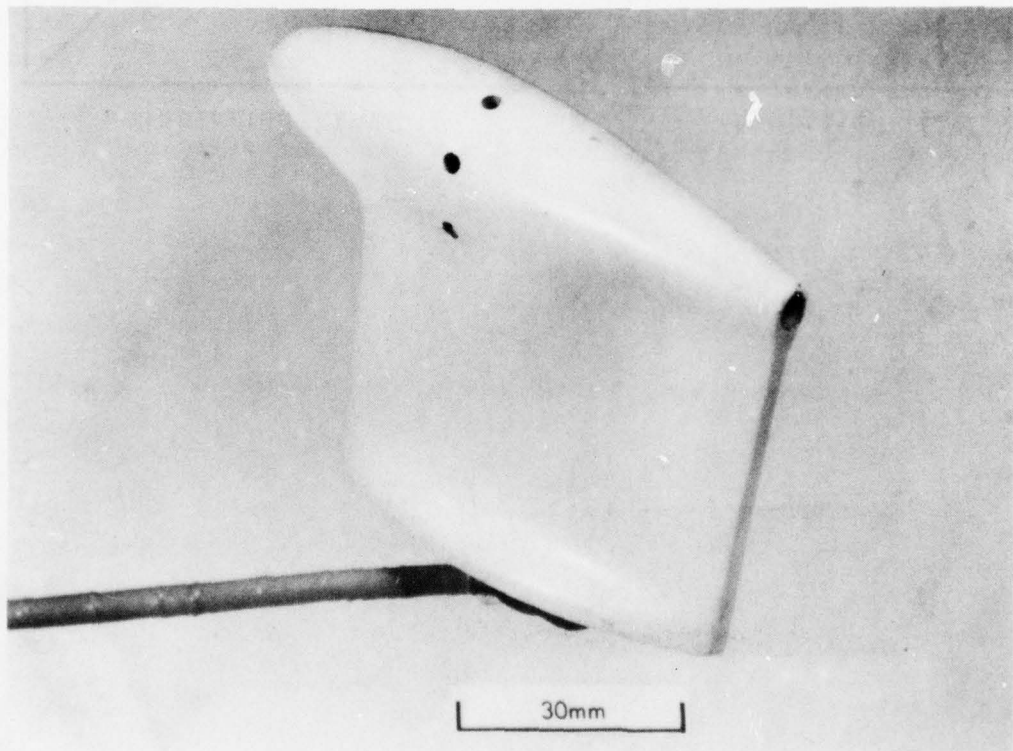

Fig 2 Rosemount oat sensing head

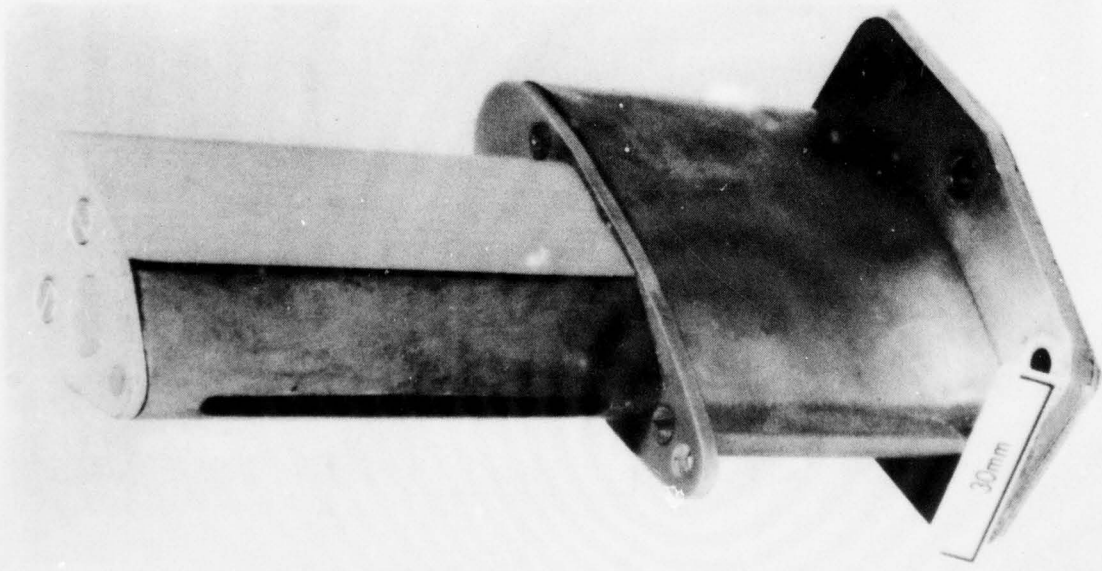
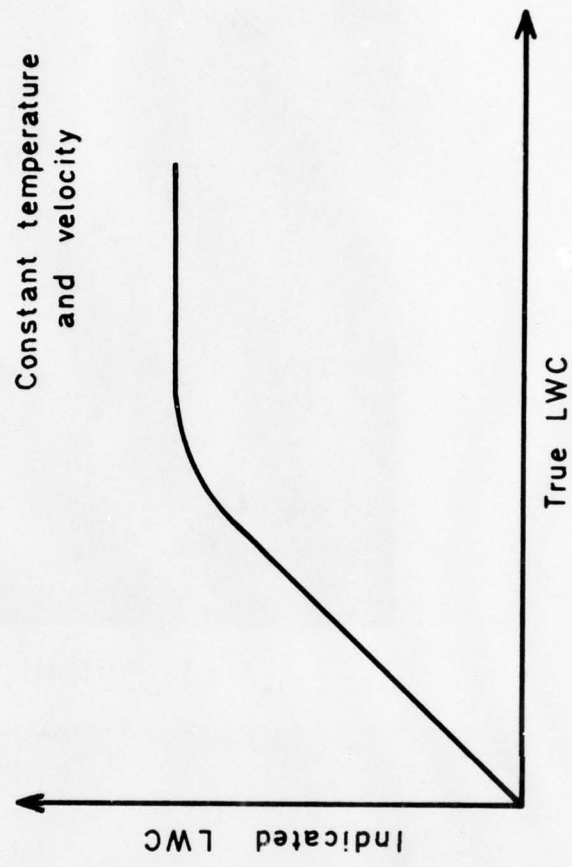

Fig 3 NGL oat sensing head

Fig 4 Accretion instrument Ludlam limit

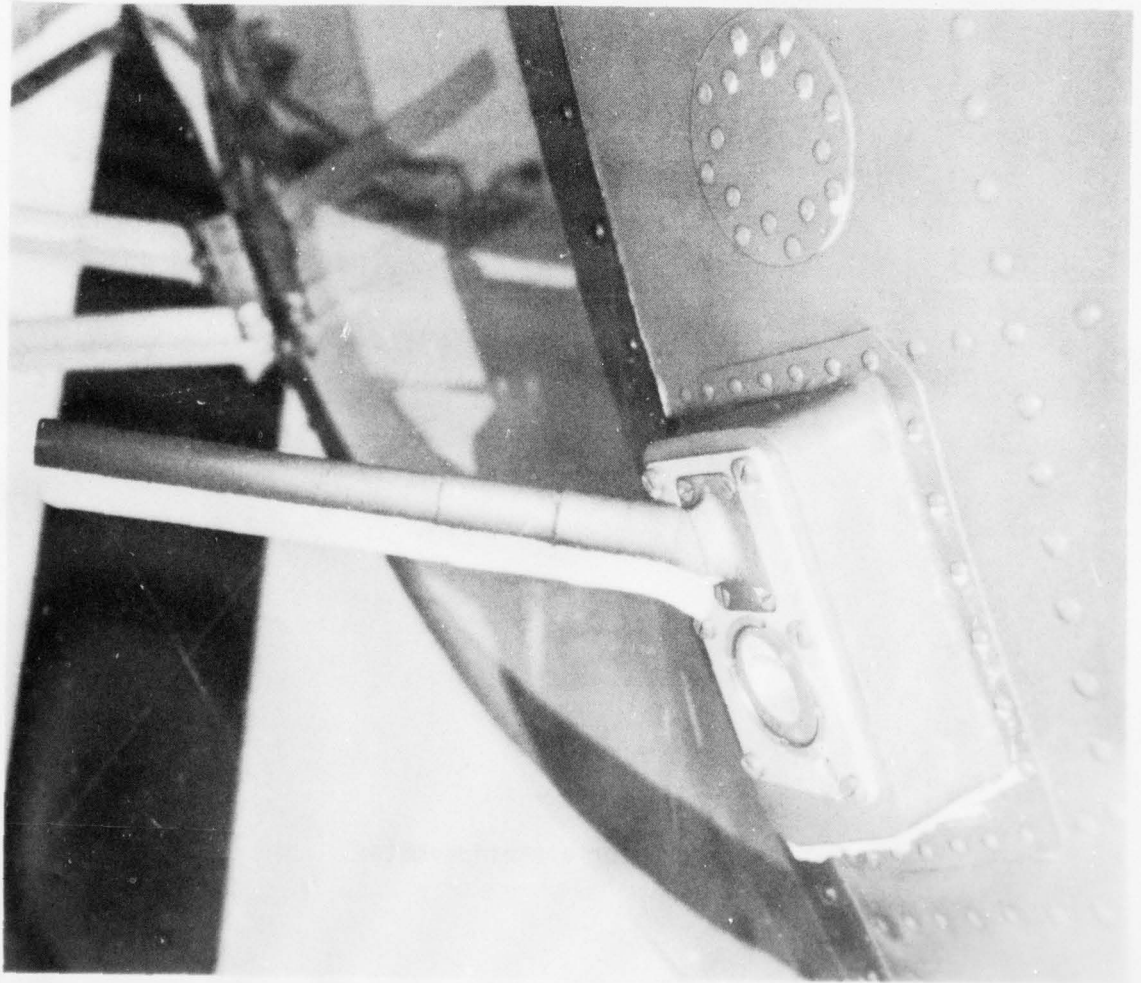

Fig 5 Accretion rod

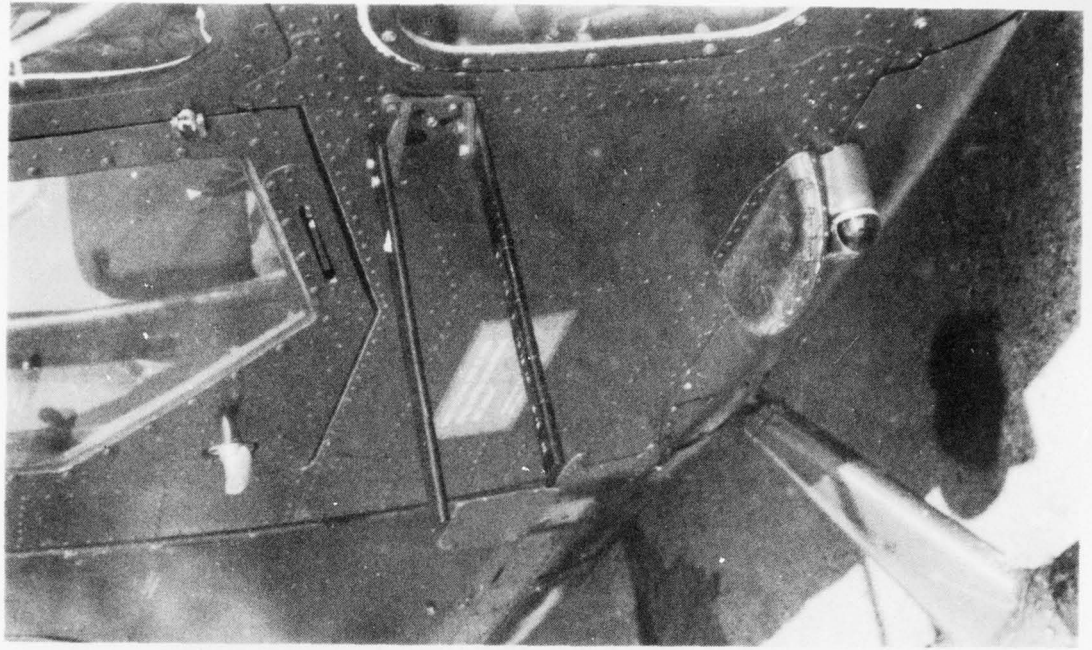

Fig 6 Vernier accretion meter

AD-A067 981

MINISTRY OF DEFENCE LONDON (ENGLAND)
HELICOPTER ICING SYMPOSIUM, 6-7 NOVEMBER 1978, LONDON, (U)
NOV 78 T C DON

F/6 1/3

UNCLASSIFIED

NL

2 OF 4
AD
A067981

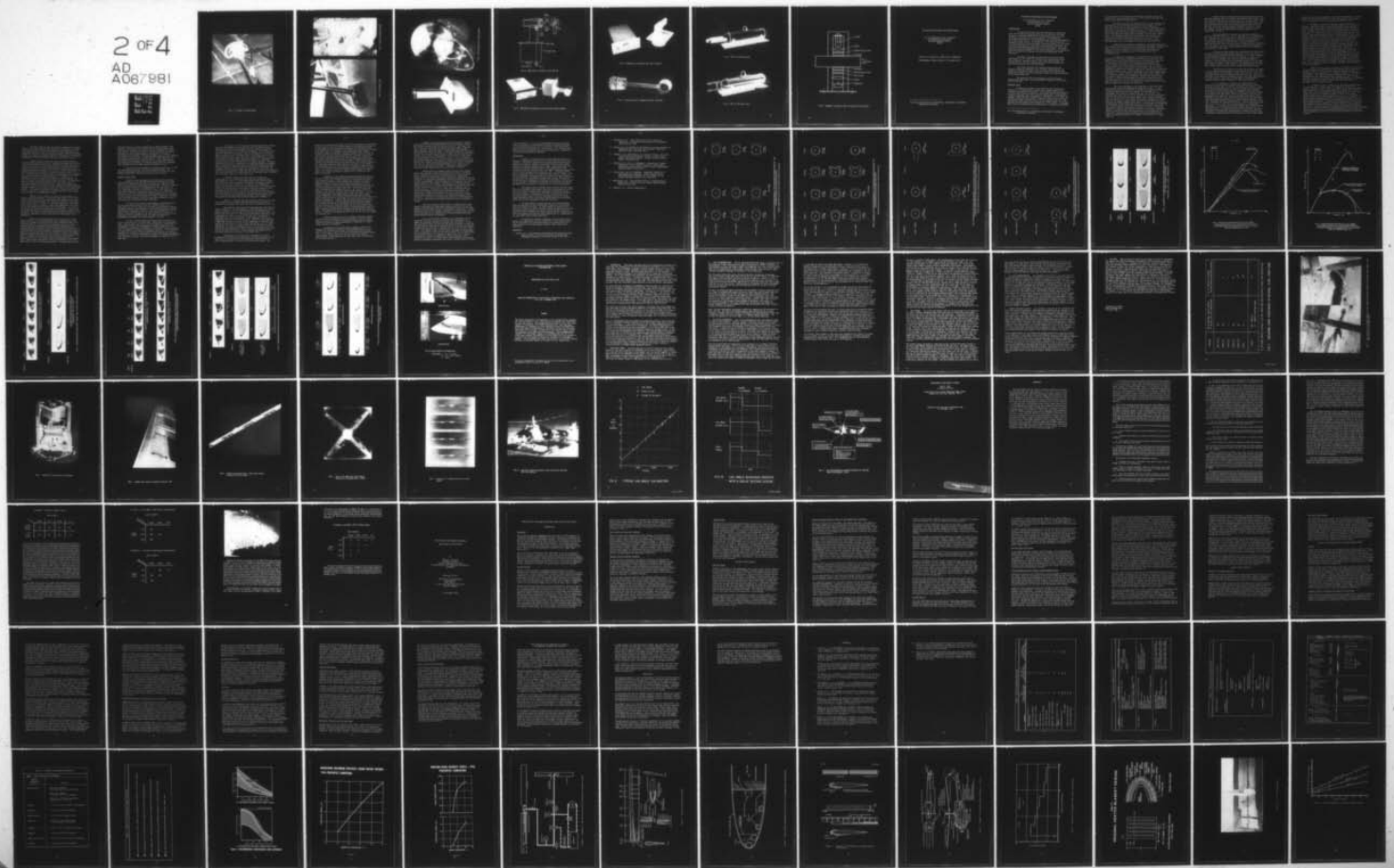

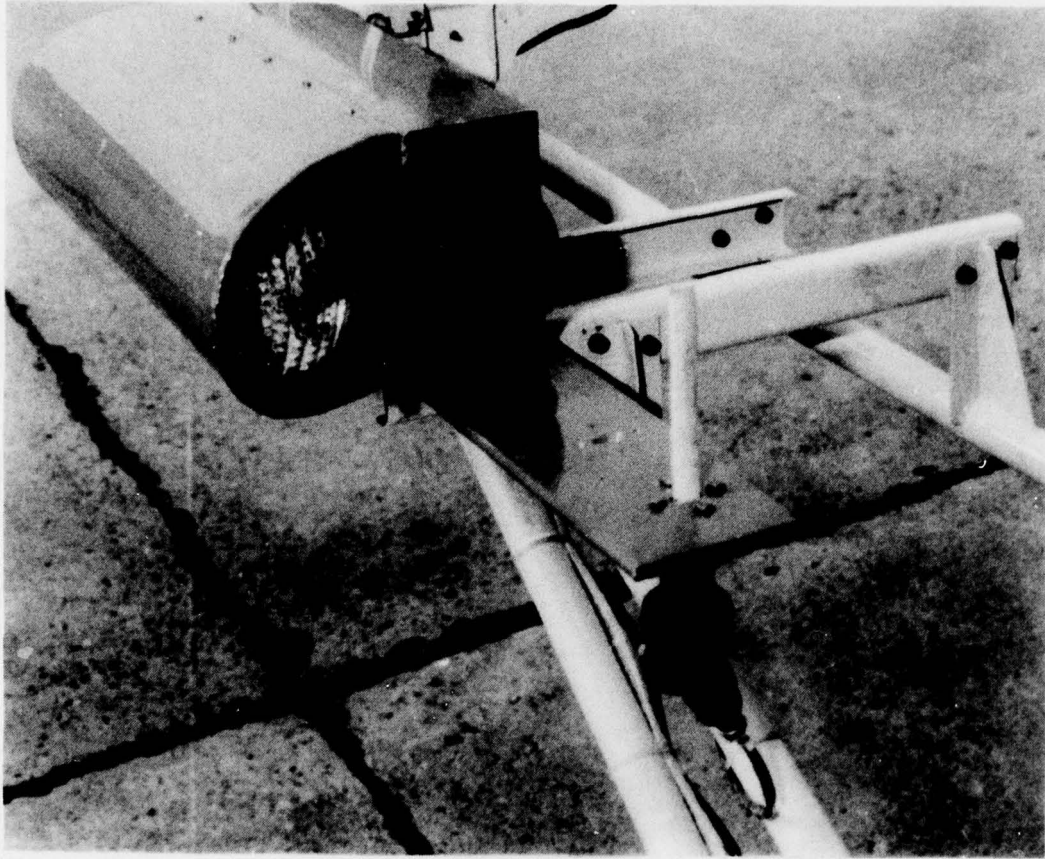

Fig 7 TV raster accretion meter

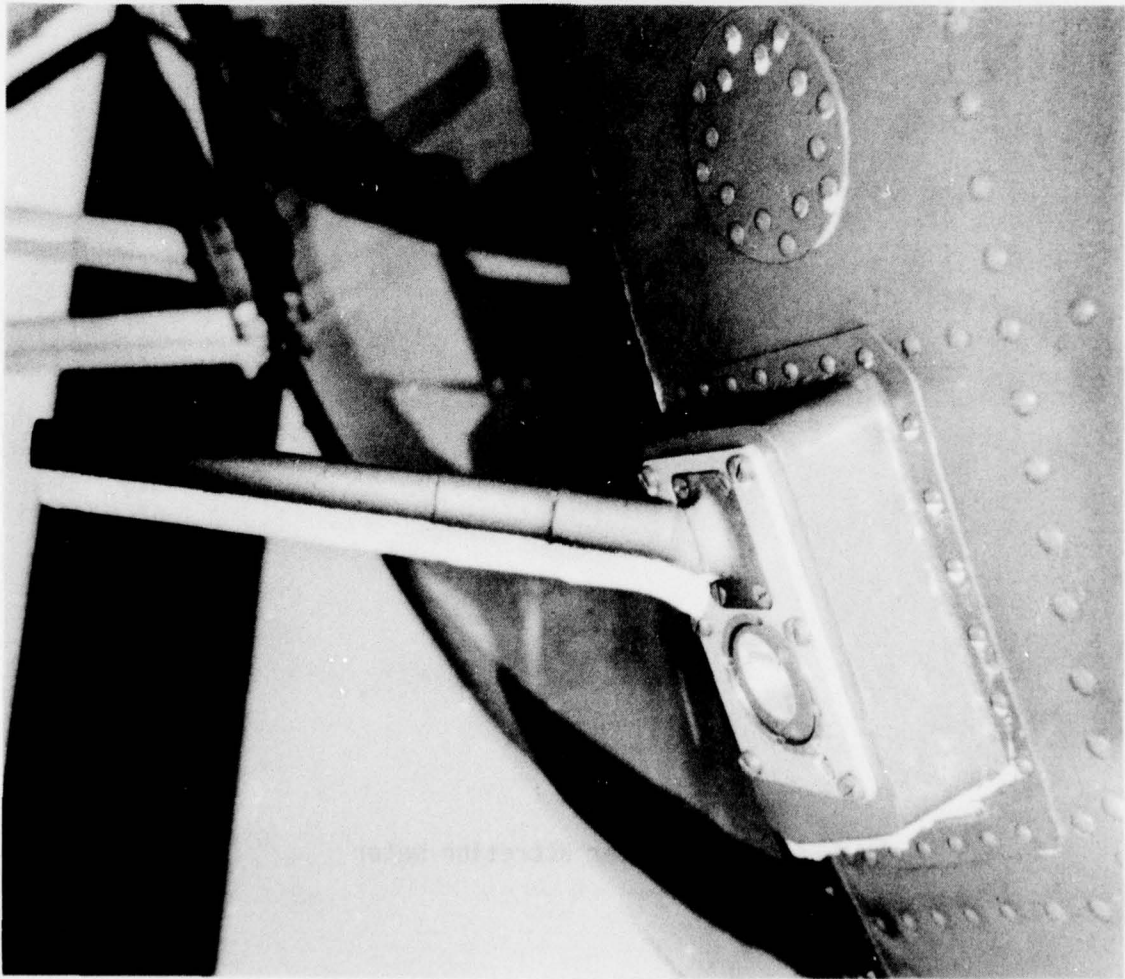

Fig 5 Accretion rod

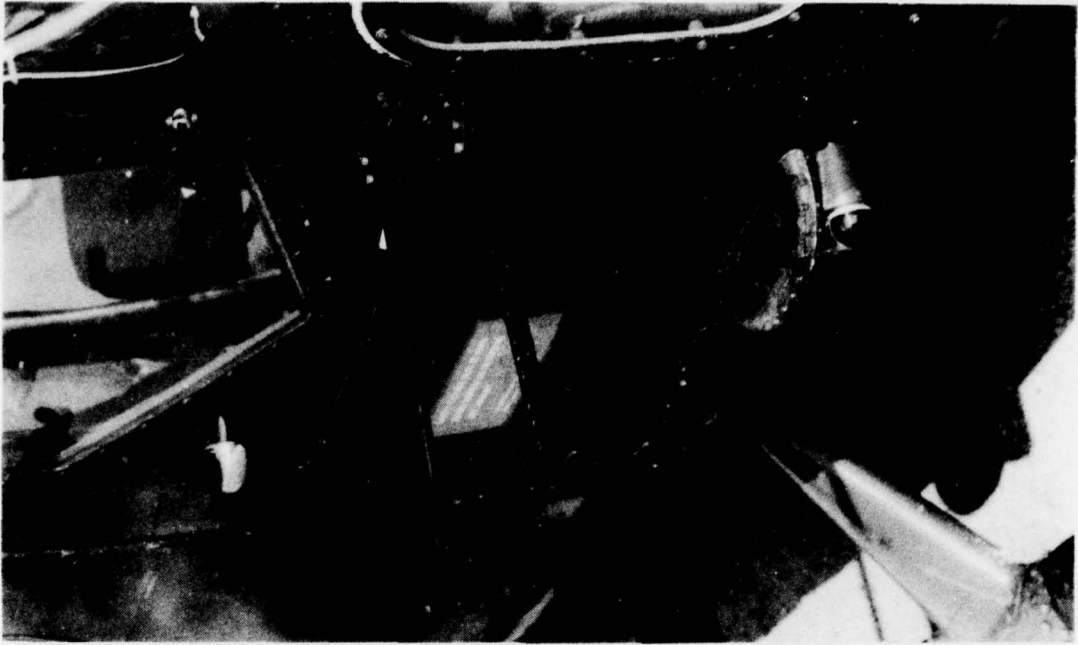

Fig 6 Vernier accretion meter

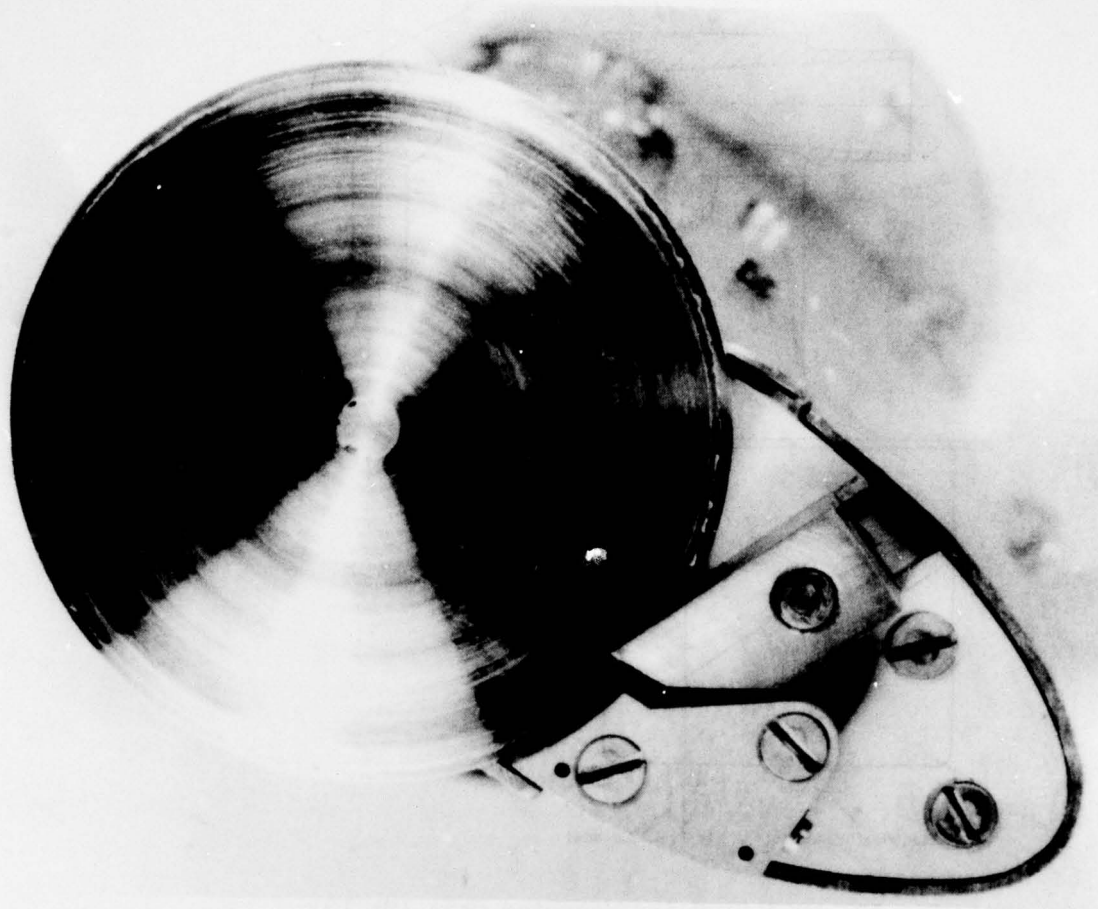

Fig 9 RAE rotating disc sensing head

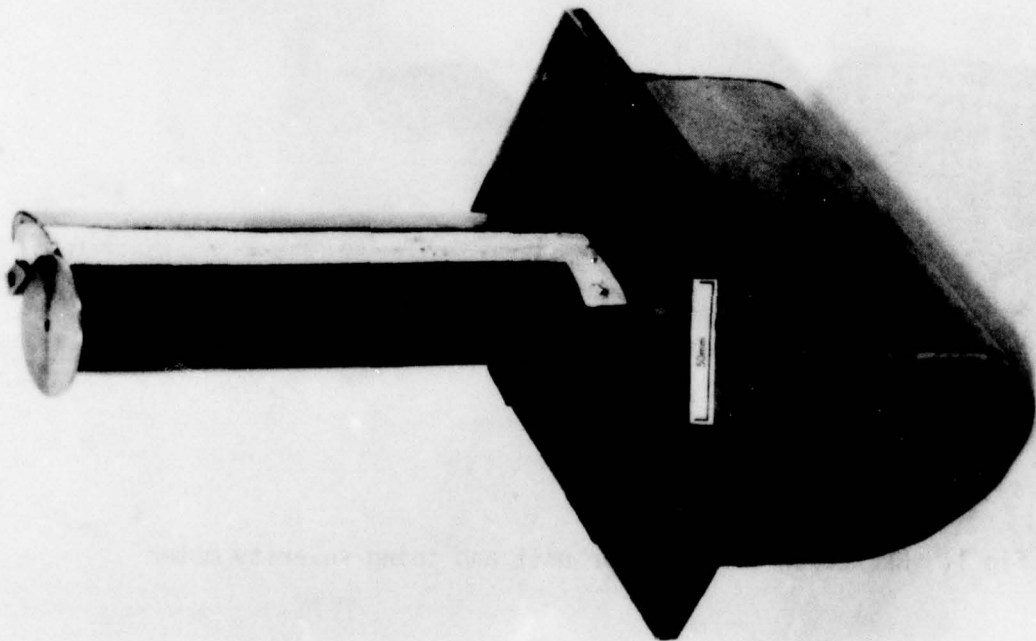

Fig 8 RAE rotating disc mast assembly

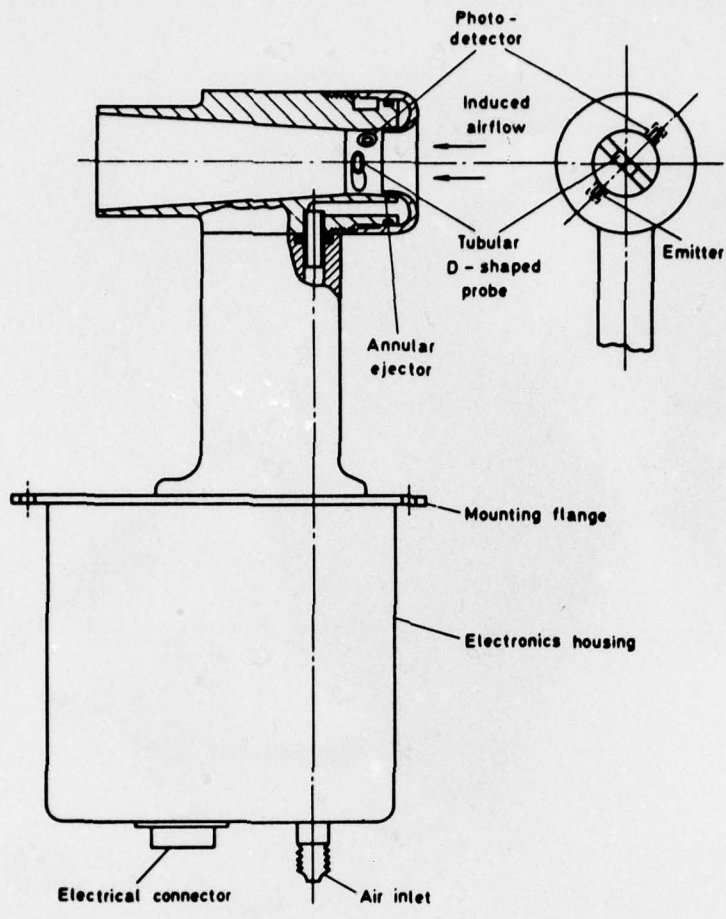

Fig 10 NRC/LEIGH ice detector unit (Mk 10)

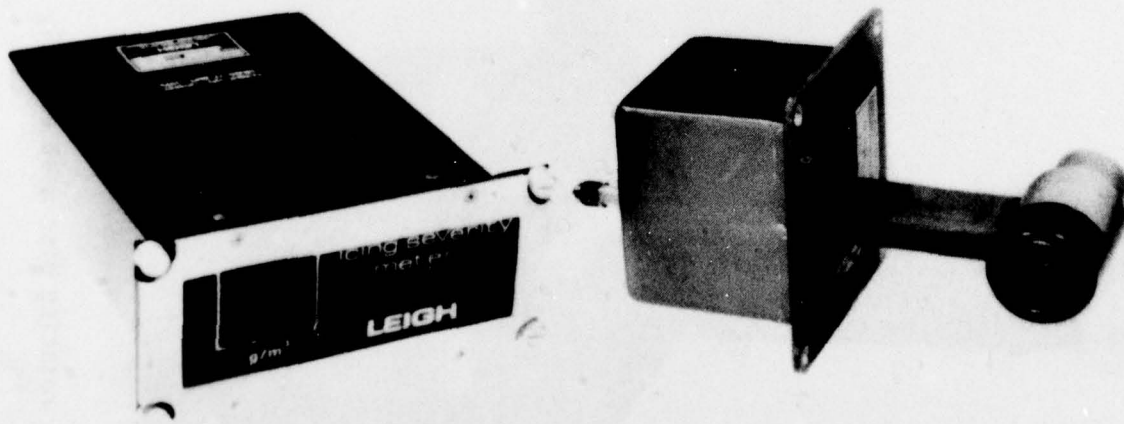

Fig 11 NRC/LEIGH ice detector unit and icing severity meter

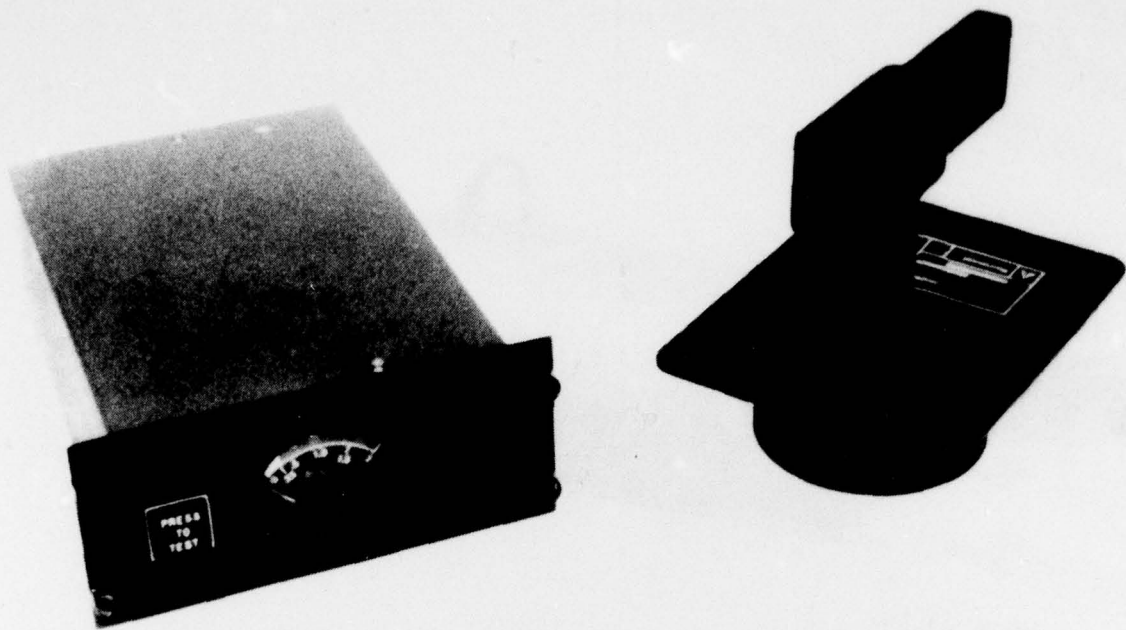

Fig 12 Rosemount ice detector and rate indicator



Fig 13 Sensing head of 'Johnson-Williams' LWC meter

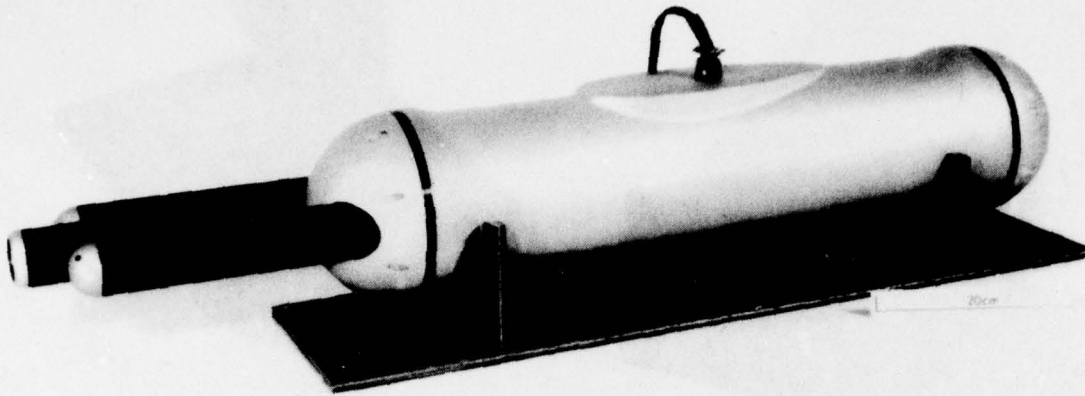

Fig 14 PMS Inc FSSP-100 probe

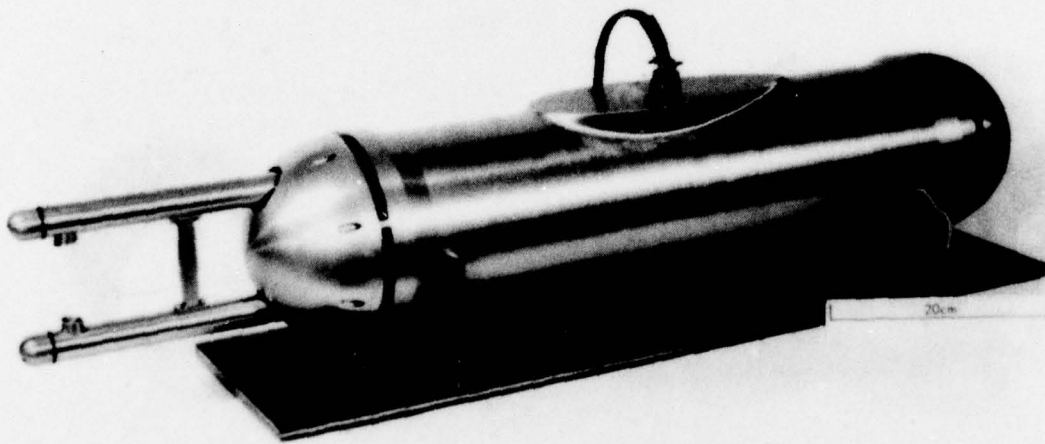

Fig 15 PMS Inc OAP-200X probe

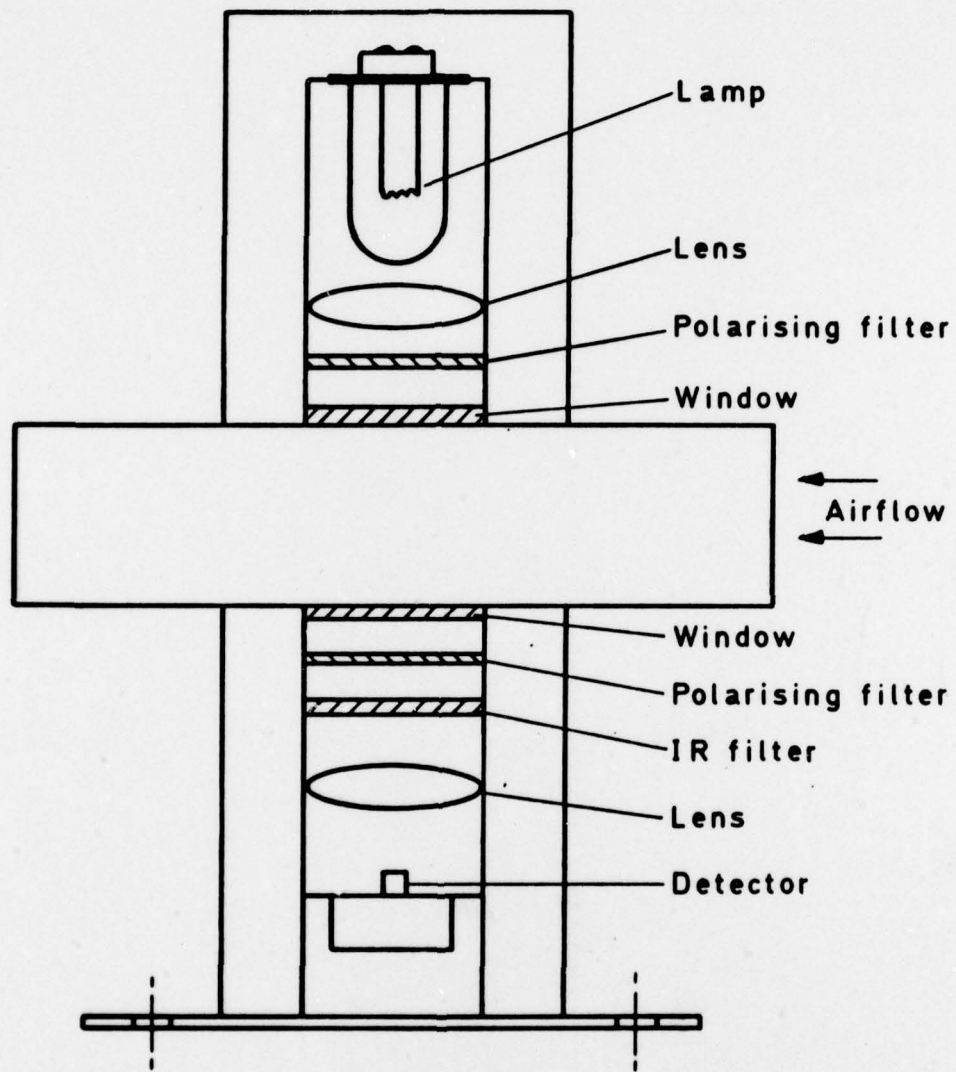

Fig 16 Schematic diagram of RAE ice particle discriminator

ICE SHAPES ON CYLINDERS AND ROTOR BLADES

J.R. Stallabrass and E.P. Lozowski*
Low Temperature Laboratory
National Research Council
Canada

Paper to be presented at NATO Panel X Symposium
on Helicopter Icing, London, 6-7 November 1978.

*on leave from Division of Meteorology, Department of Geography,
University of Alberta.

ICE SHAPES ON CYLINDERS AND ROTOR BLADES

J.R. Stallabrass and E.P. Lozowski*
Low Temperature Laboratory
National Research Council
Canada

Introduction

In spite of the fact that the phenomenon of helicopter rotor blade icing has received attention, on and off, for about 25 years, a detailed knowledge of the physical processes of ice accretion on an aerofoil is still lacking. To advance this knowledge experiments are being conducted under controlled conditions in an icing wind tunnel. In conjunction with these experiments a theoretical model is being developed which will permit the prediction of icing characteristics under given environmental conditions, and will allow the extension of results beyond the range of conditions currently achievable experimentally in the laboratory. The final verification and refinement of the model predictions will necessarily have to be made with reference to full scale helicopter icing experience.

Initially a cylinder was used both in the wind tunnel experiments and as a basis for developing the theoretical model. The cylinder is a simple shape to treat both theoretically and experimentally, and one for which many of the heat transfer and collision parameters are well determined.

This paper describes the combined experimental and numerical modelling approach to the cylinder icing problem, and presents a comparison between icing on aerofoils in the NRC high speed icing tunnel and rotor blade icing under full scale conditions in the Ottawa spray rig.

The shapes of the ice accretions receive particular attention in this paper, and some emphasis is given to icing under mixed conditions.

Cylinder Icing

Although an aerofoil icing model has been described in Reference 1, its predictions have not yet received careful and extensive experimental evaluation. In fact most practical estimates of rotor blade icing have until now been based upon the equivalent cylinder stagnation line icing model of Reference 2. This model is capable of qualitatively predicting the accretion shape by using the concepts outlined in Reference 3. However, since it does not take into account explicitly the details of the runback water, it is not possible to make quantitative predictions of ice shapes. The present model which is described fully in Reference 4, represents an attempt

*on leave from Division of Meteorology, Department of Geography,
University of Alberta.

to take runback into account more explicitly and also permits the simulation of mixed condition icing. It is similar in several ways to the model outlined in Reference 5.

The model requires the cylinder diameter, the airspeed and temperature, the liquid water and ice particle contents, and the size distribution of the cloud droplets as input parameters. Beginning at the forward stagnation line, it solves the steady state heat balance equation at 5° intervals around the cylinder surface, to obtain the local equilibrium surface temperature, the ice fraction of the impinging and runback water substance, and the local rate of icing. The unfrozen liquid with any entrained ice particles is allowed to run back successively from one 5° sector to the next, participating in the local heat exchange along the way. Any unfrozen water at 90° is assumed to be shed into the airstream.

Under the mixed accretion conditions, the model assumes an ice sticking efficiency hypothesis based on thermodynamic considerations only, along with the notion that ice particles can stick to a wet surface but not to a dry one. It will be seen later that this assumption is not consistent with the observations of mixed accretion shapes.

An important limitation of the model is its lack of time dependence. The surface temperature and the icing rate which the model predicts are initial values valid at the onset of icing only. In order to use these data to predict an accretion shape after several minutes of growth, it is necessary to extrapolate the initial values over the specified growth period. This is done by assuming that the ice has a density of 890 kg/m³, and the growth direction is radial when there is runback and forward (i.e., upstream) when the surface is dry. These assumptions ignore the evident local variability of the ice density, especially in the rime feather region or if there is spongy ice, and they do not allow for the effect of the changing shape upon the collection efficiencies and the heat transfer. A time dependent model for cylinder icing has recently been developed (Ref. 6), but unfortunately it does not take into account runback, so that it is necessary to assume rather than being able to predict the shape of the accretion.

The icing experiments were undertaken in the high speed icing tunnel in the Low Temperature Laboratory at NRC. A black bakelite cylinder 12" long and 1" in diameter was mounted across the tunnel working section, and exposed to a constant icing environment for a period of between one and five minutes. The airspeeds used were 30.5, 61, 91.5 and 122 m/s, the air temperatures were -5° and -15°C, and the liquid water contents were nominally 0.4, 0.8 and 1.2 g/m³. The actual liquid water content was measured using the rotating cylinder method and sometimes differed by up to 15% from the nominal values quoted above. The drop size distribution, as determined by the oiled slide method, was approximately exponential with a median volume diameter between 17 μm and 25 μm. When using the model to simulate individual experimental cases, the measured value of the liquid water content was used as an input to the model. However, because the drop size distribution was not measured in every case, the model did not employ the measured spectrum, but rather a standard spectrum with a median volume diameter of 20 μm (Ref. 4).

Mixed conditions were achieved in the tunnel by combining the spray droplets with ice crystals from freshly fallen snow. The snow was collected out of doors and placed on a cooled conveyer belt from which it fell into the tunnel plenum at a constant rate. The ice particle concentration in the tunnel airstream was determined with the sprays off, using an array of collector tubes in which the snow was caught and subsequently weighed. Generally, though not always, the ice particle content was made similar to the liquid water content.

The experimental ice shapes were recorded by making a plasticene impression of the surface, removing it, and photographing it. Subsequently, the accretion was sectioned near the center of the cylinder, the closer half was removed, and a photograph was taken looking along the cylinder axis. These two methods of recording the shape were used as a basis for determining the outlines shown in Figures 1 to 4. In each case, the experimental profile is reproduced on the right of the cylinder with the corresponding model profile on the left.

Because the model growth was considered to be radial under wet surface conditions and forward under dry, there were several instances where an unrealistic discontinuity in the growth occurred at the boundary between a wet and a dry surface. In such cases, the wet and dry segments of the profile were joined smoothly together. Such an adjustment was sometimes necessary for the model predictions, because it does not allow for shedding of water into the airstream, except at 90° , while in the experiments it is likely that surface water was shed from the sideways-protruding horns.

The results for liquid water only are presented in Figure 1 for an airstream temperature of -15°C , and in Figure 2 for -5°C . In these figures, the airspeed increases from left to right, while the liquid water content increases from top to bottom. Thus the "wetness" of the accretion increases both to the right and downwards in these figures. This fact is quantified by displaying the stagnation line freezing fraction, n , below each profile.

It is convenient to discuss the experimental and theoretical ice profiles in terms of the classification scheme devised by Dickey (Ref. 3) for ice accretions on cylinders. When $n = 1$ at the stagnation line, there is no runback and the radius of curvature of the deposit near the stagnation line decreases with time, giving rise ultimately to a sharp leading edge denoted as a "knife edge" accretion. When $n < 1$ runback begins near the stagnation line, while if $n < n_c$, a critical value which Dickey estimates to be about $2/3$, the runback flux is sufficiently large that the radius of curvature of the deposit front increases with time, eventually becoming negative (i.e., concave) and giving rise to, a "mushroom" or "ramshorn" accretion. For intermediate values of n (i.e., $1 > n > n_c$), the accretion takes on a "spearhead" appearance. It is difficult to use Dickey's classification scheme quantitatively in a discussion of the results presented in the figures, because the shape descriptions are qualitative ones and are subject to individual interpretation. Moreover, some of the "classical" shapes may only be achieved after rather longer growth

periods than have been employed in the present experiments. It will be seen in the ensuing discussion, that the present results appear to be in general qualitative agreement with Dickey's scheme.

In Figure 1, there are three dry cases for which $n = 1$, (1,2,4). In each of these, the accretion appears to be growing in a fashion consistent with the Dickey knife-edge classification, that is, with a diminishing radius of curvature at the stagnation line. However, the growth of the rime feathers detracts from the appearance of a "knife-edge" shape. The three model profiles are in quite acceptable agreement with the experimental profiles, except in the region of rime feather growth. If this growth region were modelled with the use of a lower ice density than the 890 kg/m^3 assumed, an even better level of agreement could probably be achieved. There are three cases for which $1 > n > 2/3$, and in each of these the experimental profiles are rather similar. The runback gives rise to a shallow stagnation line depression with a ridge on either side where the runback ceases. Since this stagnation line hollow appears to narrow with time, it may be expected that longer growth times would eventually lead to the classical "spearhead" shape. In two of these cases (5 and 7), the model predicts reasonably well both the occurrence and extent of the stagnation line depression. In the other case (3), the model fails to predict the extent of the observed runback, although it does at least indicate that the stagnation line accretion is wet ($n = 0.97$). Again in these three cases, the model growth near the edges of the accretion fails to simulate adequately the development of the rime feathers.

There are three cases in Figure 1 for which $n < 2/3$ (6,8,9). In each of these, the accretion has not yet acquired the classical mushroom shape, but the flat front suggests that the growth is proceeding in that direction (i.e., that the radius of curvature is increasing). Once again, the model predicted shapes are in fair agreement with the experimental ones, although in case 9 it was necessary to invoke the runback water shedding hypothesis in plotting the model profile, in order to obtain the indicated level of agreement with the observed shape.

In Figure 2 for -5° there are no dry cases although case 10 is nearly dry. In this case, the profile is essentially similar to that of case 1 (Figure 1), except for a narrow stagnation line hollow which is well represented by the model. For all the other cases, $n < 2/3$ although the experimental profiles do not all typify the classical "mushroom" shape. In four of the cases (11,12,13,14) where n lies between about .3 and .5, the surface remains convex although the radius of curvature has increased. For these cases the model predicts a flat front to the deposit with a very shallow depression. Moreover, the quantitative details of the model profiles do not agree well with the observations. In case 12 for example, runback was observed to 115° while the model runback ends at 60° . For this case too the observed stagnation line growth rate is 15 m/s while the model predicted value is only 9 m/s . Although several hypotheses have been advanced which may help to account for these discrepancies, (Ref. 4), the definitive explanation is not yet in hand.

The four cases 15, 16, 17 and 18 all have model n values below 0.3 and experimentally all have begun to develop a mushroom-like growth with a well-defined stagnation line depression. In three of these cases, (15, 17 and 18), the model predicts runback beyond 90° , which is consistent with the nature of the actual growth. However, the model is totally incapable of simulating the detailed development of the spiky icicle-like lobes of cases 17 and 18.

Cases 19 and 20 which were grown at 122 m/s exhibits a significant qualitative as well as quantitative discrepancy between the model and experimental shapes. Although the model values of n are very low (.05 and .06, respectively), the model nevertheless predicts that ice will grow at the stagnation line and that the maximum thickness will occur at 50° to 55° . On the other hand, the experimental results show no ice accumulation until about 70° or 80° , and even here the growth is light and subject to self shedding. It is suspected that this discrepancy arises because of the model assumption of equilibrium thermodynamics. In practice, the supercooled water impinging at the stagnation line requires time and a suitable freezing nucleus in order to freeze. If nucleation does not occur sufficiently quickly, the water will simply be carried backwards and no ice will grow. Even if nucleation does take place, however, the dendritic ice growing in low concentrations in large amounts of water may be unable to adhere to the underlying surface. This possible explanation requires further verification since it may help to explain the comparatively slow initial build up of ice under other conditions as well.

Figures 3 and 4 present the model and experimental ice shapes for mixed accretion. The two dry cases grown at -15°C (21 and 22) demonstrate that the experimental ice shapes do not differ substantially from those grown in supercooled droplet clouds alone (c.f. cases 1 and 4 in Figure 1). The only appreciable difference occurs between cases 4 and 22. Under mixed conditions, the extent of the rime feather growth appears to be diminished. This may be the result of erosion by the impinging ice particles. Under these dry conditions the model assumes that no ice crystals adhere to the accretion. The fact that the model and experimental profiles are in substantial agreement in these cases tends to corroborate this assumption.

Under wet conditions (cases 23, 24 and 25), the model shapes begin to deviate significantly from the experimental ones. This is the result of an error in the model assumptions about the sticking efficiency of ice crystals impacting on a wet surface. A comparison of the experimental profiles under liquid only and mixed conditions, indicates that the profile cross-sectional area actually decreases when ice crystals are added to the airstream. On the other hand, the model predicts a substantial growth enhancement where the ice crystals stick to a wet surface. Clearly the actual sticking efficiency cannot be nearly as great as that assumed in the model. Moreover the ice crystal collisions may even lead to splashing of some of the surface water, thereby reducing the growth rate. Some of these suspicions have been confirmed by high speed photography of the ice particle collisions. In most cases, the ice

particles shatter on impact leaving only a small residue in the surface. The remainder is carried away by the airstream. This effect can be detected even without special equipment by careful observation. During mixed icing, a fine spray can be seen to be bouncing off the upstream surface from whence it is carried downstream in the airflow. In some instances (case 24, for example), the mixed accretion profile is substantially different from the corresponding liquid only profile (case 7). This appears to be the result of two effects: erosion of the lateral rime feathers (streamlining) and splashing of runback water near the stagnation line, giving rise to a valley along the stagnation line.

Because of these phenomena, the model predictions at -5°C are similarly inconsistent with the observed profiles. The greatest discrepancy occurs in case 31 (Figure 4) where the model predicts substantial icing which does not in fact occur.

Aerofoil Icing Tests

Aerofoil icing experiments were made in the high speed icing wind tunnel on an NACA 0015 section of 8.375-inch (213 mm) chord and 12 inches (305 mm) span (a section of a Bell UH-1 tail rotor blade of aluminum honeycomb construction). Tests were made as for the cylinder tests at two temperatures, -5°C and -15°C , at four velocities from 100 to 400 ft/sec. (30.5 to 122 m/s), and at four fixed angles of incidence from 0° to 12° in 4° increments. Basically two nominal liquid water contents were used (0.4 and 1.2 g/m³) and a few tests were made in mixed conditions by the addition of snow crystals to the wind tunnel air flow. Generally a 5-minute icing time was employed, except for conditions conducive to high rates of icing, when shorter times were used.

At the end of each run, measurements and photographs of the ice were made as described for the cylinder tests, and impressions of the ice shape were made using the plasticene mould technique described in Reference 2. Since the plasticene, when the impression is being made, tends to break off or damage some of the more delicate feathery type of ice, some touching up of the ice profile silhouette photographs has been done with reference to the photographs and measurements made, in order to reproduce as faithfully as possible the actual profile of the ice.

In Fig. 5 the recorded ice shapes from two sequences of tests at 0.4 g/m³ and -15°C are shown. These show the progression from a "knife edge" ice shape at 61 m/s (although at this stage of development it might more reasonably be called "streamlined" or "conformal"), through the "spearhead" or intermediate form at 91.5 m/s, to a moderate "mushroom" formation at 122 m/s. This progression is shown both for zero angle of incidence and for 8° . It will be noted how, at incidence, these forms become distorted but are still recognizable. In this and subsequent figures, ice profile silhouettes from the tunnel aerofoil tests are reproduced at a scale of 0.6 x full size.

The manner in which the rate of icing varies with velocity for all test sequences at 0.4 g/m^3 and -15°C is shown in Fig. 6, together with the results obtained from the numerical model for the stagnation line of a 25.4 mm dia. cylinder. It is evident that the blade stagnation line rate of icing is highest at 0° pitch as might be expected, but that the trend of decreasing rate of icing with increasing pitch is somewhat upset by the points at 12° angle which gave a slightly higher icing rate than the 8° cases (tests at 12° at the two higher speeds have not yet been run), although measuring errors could account for this apparent anomaly. Beyond a velocity of 91.5 m/s, a transition to a mushroom formation commences and the stagnation line rate of ice formation eventually decreases, while, within the velocity limits of these tests, the maximum ice thickness occurring at the upper peak continues to increase. The results from the numerical model indicate that to a first approximation the blade stagnation line icing rate can be estimated using a cylinder having similar stagnation catch efficiency.

A similar sequence of tests, but at a static air temperature of -5°C , resulted in the icing rate characteristics demonstrated in Fig. 7. At this temperature, all the test points were in the wet growth regime, with mushroom formations occurring at 61 m/s and higher velocities. At 122 m/s, the stagnation region, and the lower surface at all angles except 0° , remained free of ice, ice forming only on the upper surface but tending to grow forward into the airstream. It was not possible to obtain a meaningful measure of the icing rate of this growth since fragments were continually shed in the wind, thus limiting the overall growth to 5 to 10 mm, but never projecting forward of the leading edge, the greater growth occurring at greater angles of incidence.

In Fig. 7, results from the numerical model for a 25.4 mm. dia. cylinder are also shown, and again show that a reasonable estimate of stagnation line icing rate may be obtained in this way.

The question arises as to how representative are these ice shapes produced in the icing tunnel of those obtained under actual flight conditions. In Fig. 8 comparison is made between tunnel results and those from a flight of a Sikorsky S-55 helicopter in the Ottawa spray rig (Ref. 7). The flight test profile silhouettes are reproduced at a scale of about $0.4 \times$ full size. The tunnel conditions were 0.4 g/m^3 and -15°C at 8° incidence, while flight conditions were about 0.2 g/m^3 at -14°C . The S-55 rotor blade had a NACA 0012 section of 16.4 in. chord, resulting in a leading edge profile not dissimilar to that of the tunnel model. The ice shape comparisons are seen to be good, except for the velocity at which transition to a mushroom formation occurs; this is between 100 and 120 m/s for the tunnel tests, whereas for the helicopter tests it is seen to be closer to 150 m/s. This, however, is consistent with the lower liquid water content of the flight tests.

The flight time in Fig. 8 was 14 minutes; if this is extended to 38 minutes under essentially the same conditions, it is found that the accretion has now developed as shown in Fig. 9, with a maximum growth of 31 mm in the 50-60% span region. The

unusual ice form beyond 75% span is not easily explained, particularly as this should be in a wet growth regime; it is likely the result of a combination of the increasing centrifugal acceleration and the high velocities in this region, the centrifugal acceleration resulting in surface water in a fairly narrow stagnation region flowing spanwise instead of chordwise, creating a narrow core of solid ice. On the flanks of this core, potential rime ice would tend to form but would be stripped away by the high tangential air velocity. Any surface water that strayed out of the stagnation region would likely be stripped away in a similar fashion. Wind tunnel tests at higher speeds than 120 m/s are required to test these hypotheses, and to determine whether such shapes are possible in the absence of centrifugal effects. This test was in hovering flight at about 4 m/s so that cyclic pitch and velocity variations would have been minor. The cyclic variations of forward flight would not likely allow such a narrow accretion to develop and a broader ice cap might be expected.

Examples of high temperature icing are shown in Fig. 10. The test on the S-55 helicopter at -2.5°C and an estimated liquid water content of about 1 g/m^3 produced an ice deposit of rather frightening appearance. Self-shedding had occurred outboard of about 65% span on at least two occasions during the 23 minute flight, so that on landing, after full power had been attained, no ice existed beyond this radius (105 m/s). Wind tunnel runs were made at temperatures no higher than -5°C , so that no very exact comparison can be made; however, profiles for tests at 8° of incidence with LWCs of 0.4 g/m^3 and 1.2 g/m^3 are shown. In spite of the temperature difference between flight and tunnel tests certain similarities are evident bearing in mind the very much longer accretion time of the flight test which would tend to make the shapes more extreme. A tunnel test was also run at 122 m/s with LWC 0.4 g/m^3 (See Fig. 12), but because of the delicate nature of the resulting accretion, no plasticine impression was possible. At this velocity, the accretion consisted of a thin cornice-like sheet of ice projecting forward some 6 or more millimetres from the upper surface of the aerofoil just above the geometrical leading edge. The leading edge and the underside of the aerofoil were free of ice. Pieces of ice continually shed from the ice sheet throughout the 3-minute run.

These comparisons do tend to support conformity between the tunnel icing results and those experienced in actual flight; however, more tunnel tests are indicated, particularly at higher velocities, and at the same combination of conditions for which flight results are available.

Incidentally, one might wish to ponder on some of the difficulties involved in trying to model mathematically an ice accretion of the form seen in Fig. 10 resulting from the flight test. For instance, what is the local collection efficiency around such a shape, and likewise what are the local heat transfer coefficients? These things are not even known with any precision for a clean aerofoil!

A number of tests have been made in which ice crystals were added to the supercooled droplets in the airstream. Some of the results of these tests are shown in Fig. 11. The upper row ((a) - (d)) are the results of the droplet only tests, while the lower row ((e) - (h)) show the effect of adding ice crystals, other conditions being the same. A dry growth condition is shown in (a) and (e); no change in the shape or extent of the accretion was evident, but a slight (<10%) increase in the rate of icing seemed to result from the mixed conditions. Profiles (b), (c) and (d) show a progressive increase in the wetness of the ice formation in liquid only conditions; the result of adding ice crystals ((f), (g) and (h)) is a progressive proportionate reduction in the stagnation line rate of icing with increasing wetness (i.e., about 15% for (f), 75% for (g) and 100% for (h)). Similarly a progressive reduction in the overall rate of ice accretion is evident.

Perhaps even to a greater extent than for the cylinder tests, these results refute the general belief that ice crystals will be captured by the water film present in the wet ice growth regime, while not adhering to a dry ice surface. High speed movies of the ice crystal impingement showed the crystals shattering on impact, the fragments rebounding and being carried away in the air stream. Occasionally a small proportion of the crystal was seen to remain adhered to the surface. Although the resolution was not adequate to show, it is perhaps not unreasonable to assume that when a water film is present, water is also lost by splashing when a crystal impacts. In addition it seems likely that the impact of the crystals causes erosion of the existing ice accretion, thus removing or preventing the formation of rime fingers and, to a large extent, rough glaze nodules. The results of these various conjectured processes are the smaller, smoother accretions shown in Fig. 11. One feature of mixed cloud accretions, particularly at the higher velocities, is the smooth concavity in the stagnation region.

From the results of these tests, it appears that flight through mixed clouds of supercooled droplets and ice crystals may present a significantly less severe aerodynamic hazard to the rotor blades than does flight through a supercooled liquid cloud. However, insufficient data is at present available to be unequivocal on this, and in any event such a conclusion is not necessarily applicable should heated surfaces be involved.

If, as these results suggest, mixed conditions are not responsible for the high rates of torque rise experienced on a number of occasions, another explanation must be sought. It has been pointed out (Ref. 8) that at high angles of attack, a very low or even negative temperature recovery factor occurs at the location of maximum local velocity on the aerofoil (i.e. on the upper surface close to the leading edge), resulting in a high heat loss at this point. The result is that at high velocities where no icing occurs at the stagnation point or on the lower surface, ice can still occur on the upper surface. An example is shown in Fig. 12. Such an accretion can cause flow separation, and if occurring in the sensitive tip region of a rotor blade, could result in the sort of serious performance degradation that causes the high rates of torque

rise experienced. It is not yet established what are the upper limits of velocity and temperature to which this unilateral type of ice accretion can occur, nor the effect of scale and aerofoil profile on its characteristics. As an aside, it is obvious that a rotor head camera could not distinguish between such a unilateral accretion and a bilateral formation.

Conclusions

1. A model of cylinder icing has been developed which is capable of predicting the shapes of ice accretions on non-rotating cylinders. The model predictions are in best agreement with the observations when the growth is dry (apart from the rime feather region), or when the runback flux is small. When significant horn formation or runback shedding begins, the quantitative model predictions are not very accurate. The model predictions behave well at -15°C , but they are not as useful at -5°C . A similar comment could be made concerning the classification scheme of Dickey. The model predictions, which are based on a large sticking efficiency for ice crystals, are generally rather poor for wet mixed conditions. In actuality, the experiments indicate that perhaps as little as 10% or less of the impinging ice crystal mass sticks to the deposit at these speeds. The model is currently in the process of further development in an attempt to rectify some of these discrepancies.

2. The aerofoil tests indicate that, at least over the inner half of a helicopter rotor blade, the form of ice accretion obtained in flight can be reproduced with acceptable faithfulness in an icing wind tunnel. Wind tunnel tests have not yet been conducted at higher velocities representative of the outer portions of a helicopter rotor blade, so that a comparison between ice formed under conditions of high centrifugal acceleration and that formed statically in the wind tunnel is not yet available.

3. The experimental results indicate that mixed condition icing may not pose any more significant a hazard to rotor blades than does liquid only icing. In fact, within the limits of the tests so far made, the effect of mixed conditions has generally been to decrease the roughness, the extent and the overall icing rate under wet growth conditions of icing, suggesting that in some cases, the more streamlined accretion profile may result in a reduction in the drag under mixed growth conditions.

It seems more probable, therefore, that the high rates of torque rise experienced on a few occasions at a few degrees below 0°C are the result of a unilateral type of ice accretion on the upper surface of the rotor blades occurring under liquid only conditions.

References

1. Werner, J.B. Ice protection investigation for advanced rotary-wing aircraft. U.S. Army Air Mobility Research and Development Laboratory, Technical Report 73-38, 1973.

2. Stallabrass, J.R. Icing flight trials of a Bell H1L-4 helicopter. National Research Council, NAE Laboratory Report LR-197, 1957.
3. Dickey, T.A. An analysis of the effects of certain variables in determining the form of an ice accretion. Naval Air Material Center, AEL-1206, 1952.
4. Lozowski, E.P., Stallabrass, J.R., and P.F. Hearty. The icing of an unheated non-rotating cylinder in liquid water droplet-ice crystal clouds. National Research Council Report, September 1978.
5. Cansdale, J.T., and I.I. McNaughtan. Calculation of surface temperature and ice accretion rate in a mixed water droplet/ice crystal cloud. Royal Aircraft Establishment Technical Report 77090, 1977.
6. Ackley, S.F., and M.K. Templeton. Numerical simulation of atmospheric ice accretion. Paper presented at the 2nd International Symposium on Snow Removal and Ice Control Research, Hanover, N.H., May 1978.
7. Stallabrass, J.R. Icing flight trials of a Sikorsky HO4S-2 helicopter. National Research Council, NAE Laboratory Report LR-219, 1958.
8. Cansdale, J.T. Private communication.

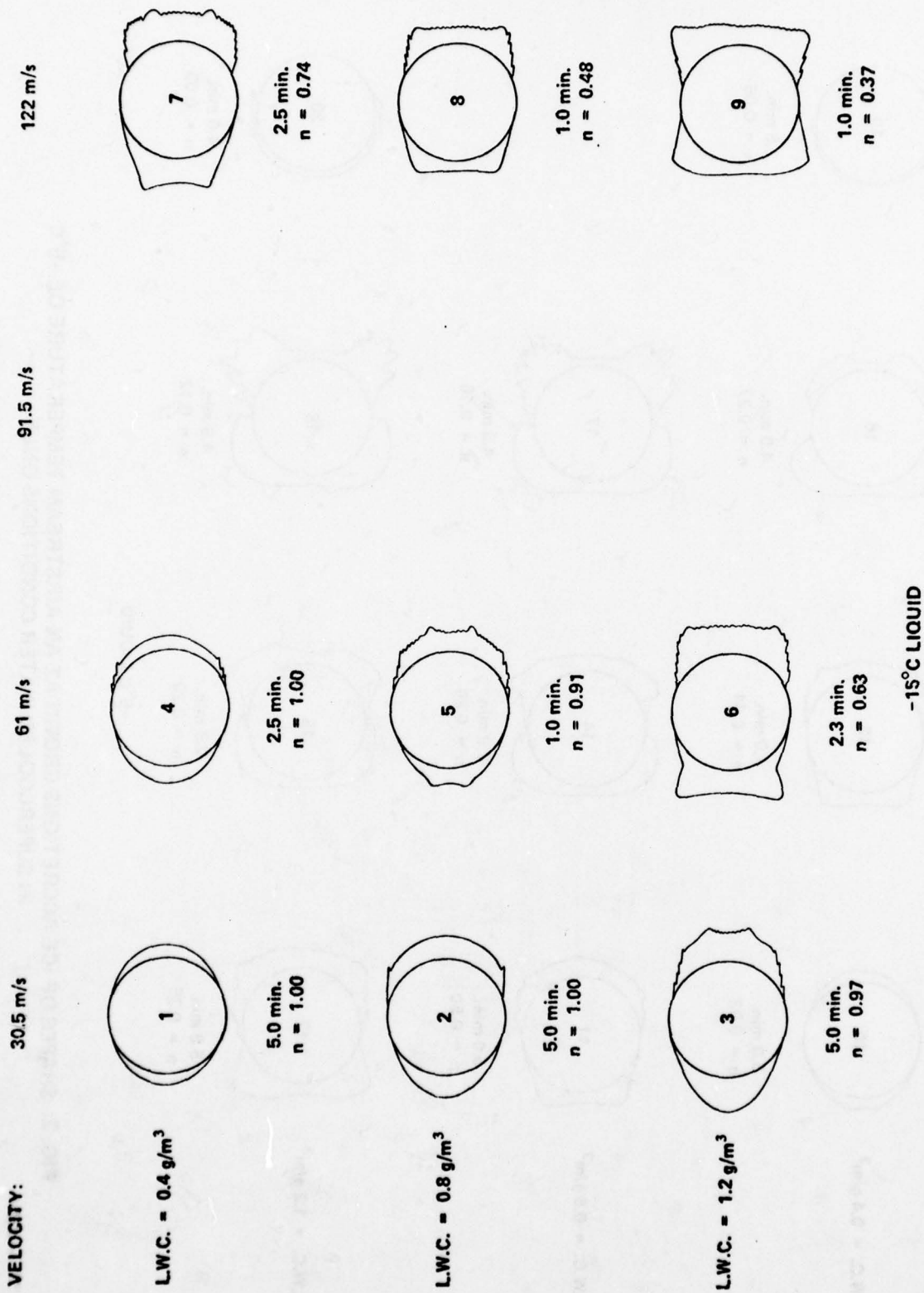
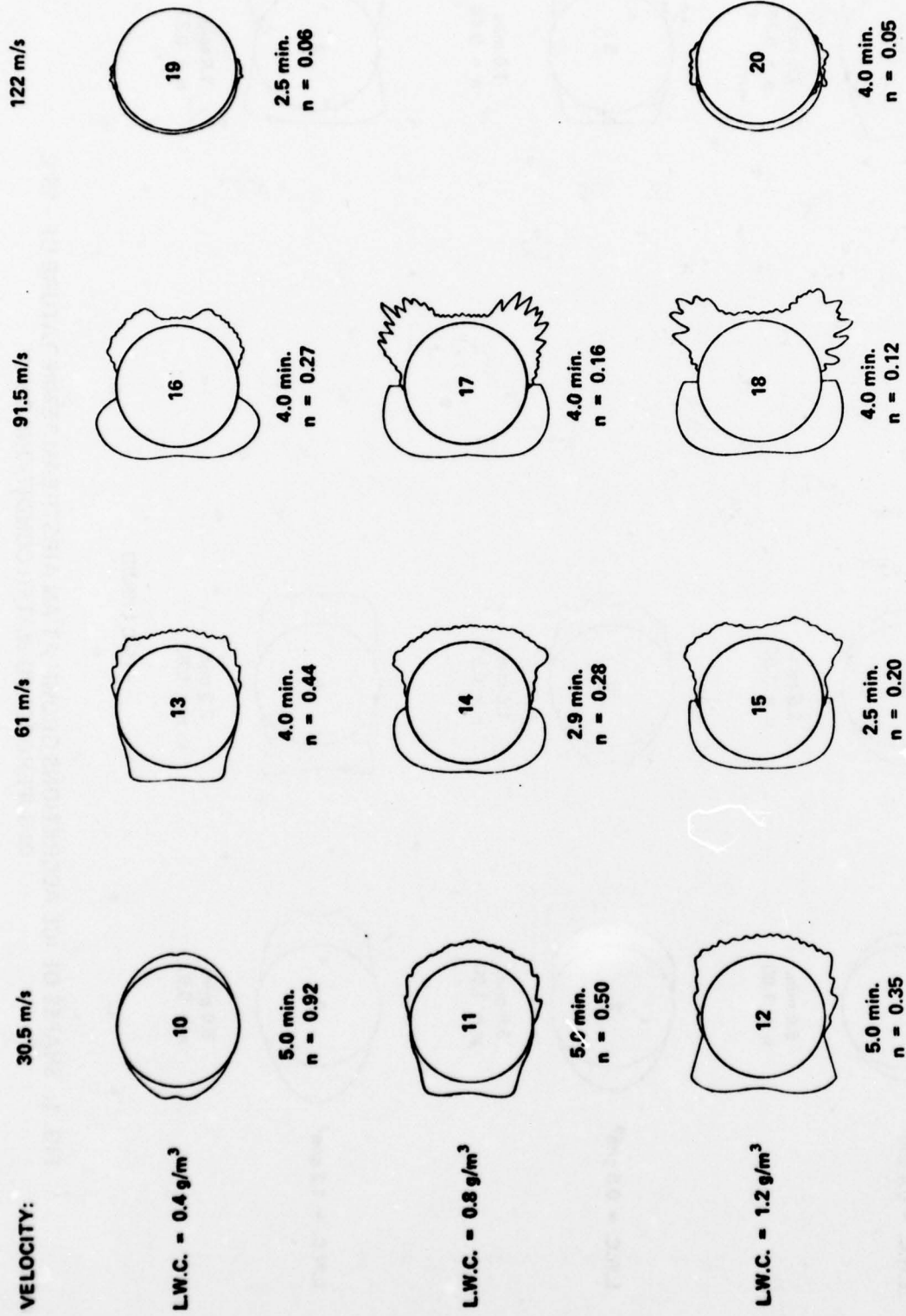

FIG. 1: SHAPES OF ICE ACCRETIONS GROWN AT AN AIRSTREAM TEMPERATURE OF -15°C
IN SUPERCOOLED WATER CONDITIONS ONLY

MODEL PREDICTIONS FACE LEFT; EXPERIMENTAL PROFILES FACE RIGHT



-5°C LIQUID

FIG. 2: SHAPES OF ICE ACCRETIONS GROWN AT AN AIRSTREAM TEMPERATURE OF -5°C
IN SUPERCOOLED WATER CONDITIONS ONLY

MODEL PREDICTIONS FACE LEFT; EXPERIMENTAL PROFILES FACE RIGHT

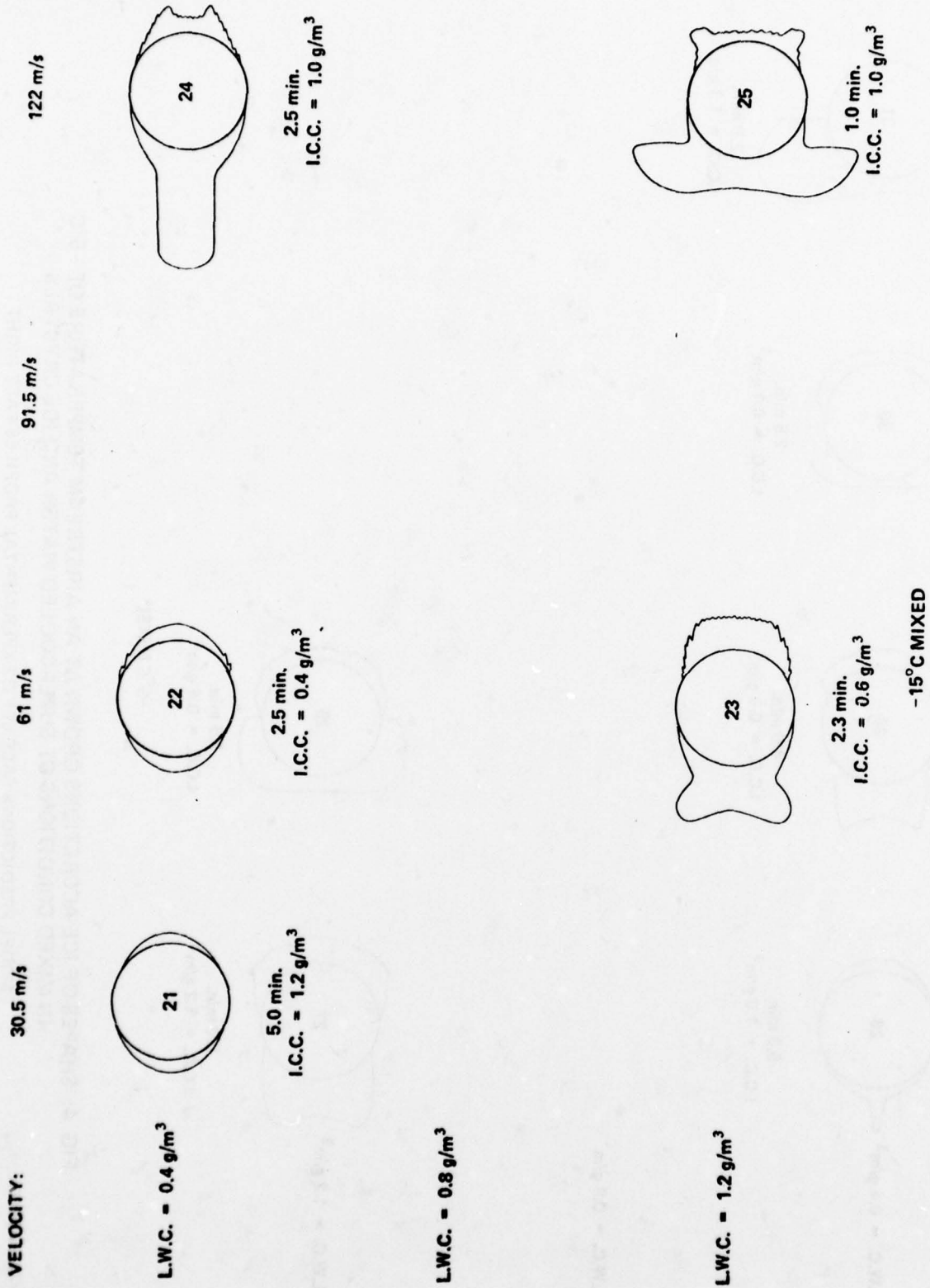

**FIG. 3: SHAPES OF ICE ACCRETIONS GROWN AT AN AIRSTREAM TEMPERATURE OF -15°C
IN MIXED CONDITIONS OF SUPERCOOLED WATER AND ICE CRYSTALS**
MODEL PREDICTIONS FACE LEFT; EXPERIMENTAL PROFILES FACE RIGHT

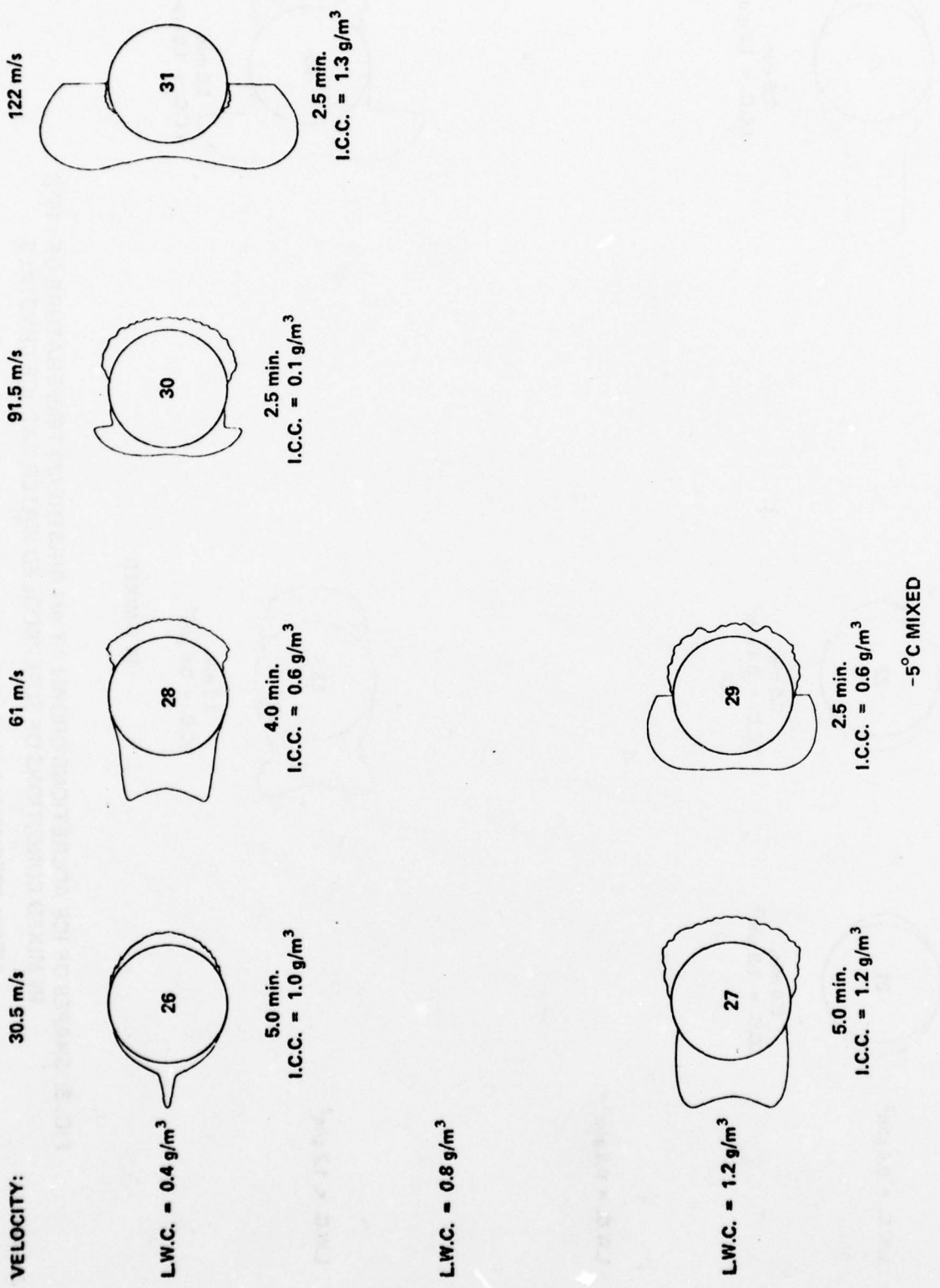

FIG. 4: SHAPES OF ICE ACCRETIONS GROWN AT AN AIRSTREAM TEMPERATURE OF -5°C IN MIXED CONDITIONS OF SUPERCOOLED WATER AND ICE CRYSTALS
 MODEL PREDICTIONS FACE LEFT; EXPERIMENTAL PROFILES FACE RIGHT

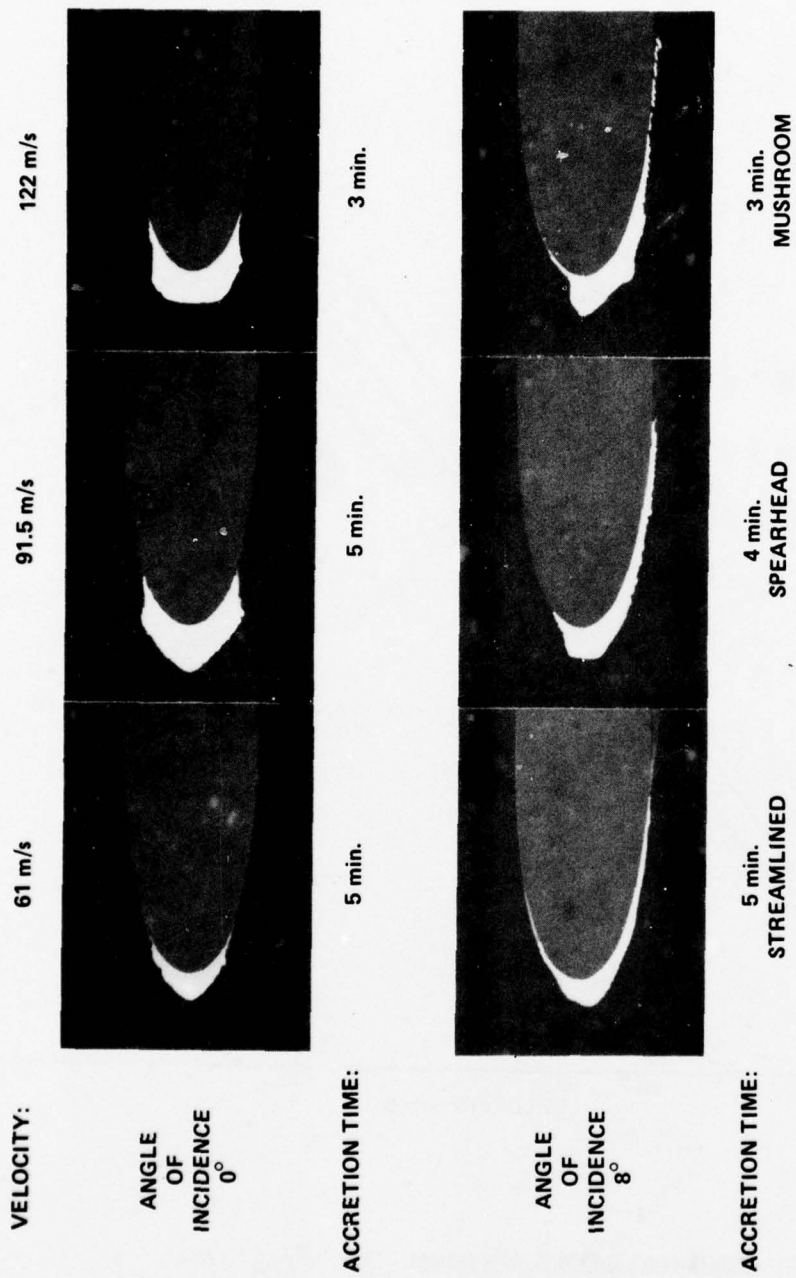

FIG. 5: CLASSICAL ICE SHAPES ON 8.375 INCH CHORD NACA 0015 AEROFOIL AT 0° AND 8° ANGLE OF INCIDENCE

CONDITIONS: L.W.C. = 0.4 g/m³ TEMPERATURE = -15°C

T = -15°C

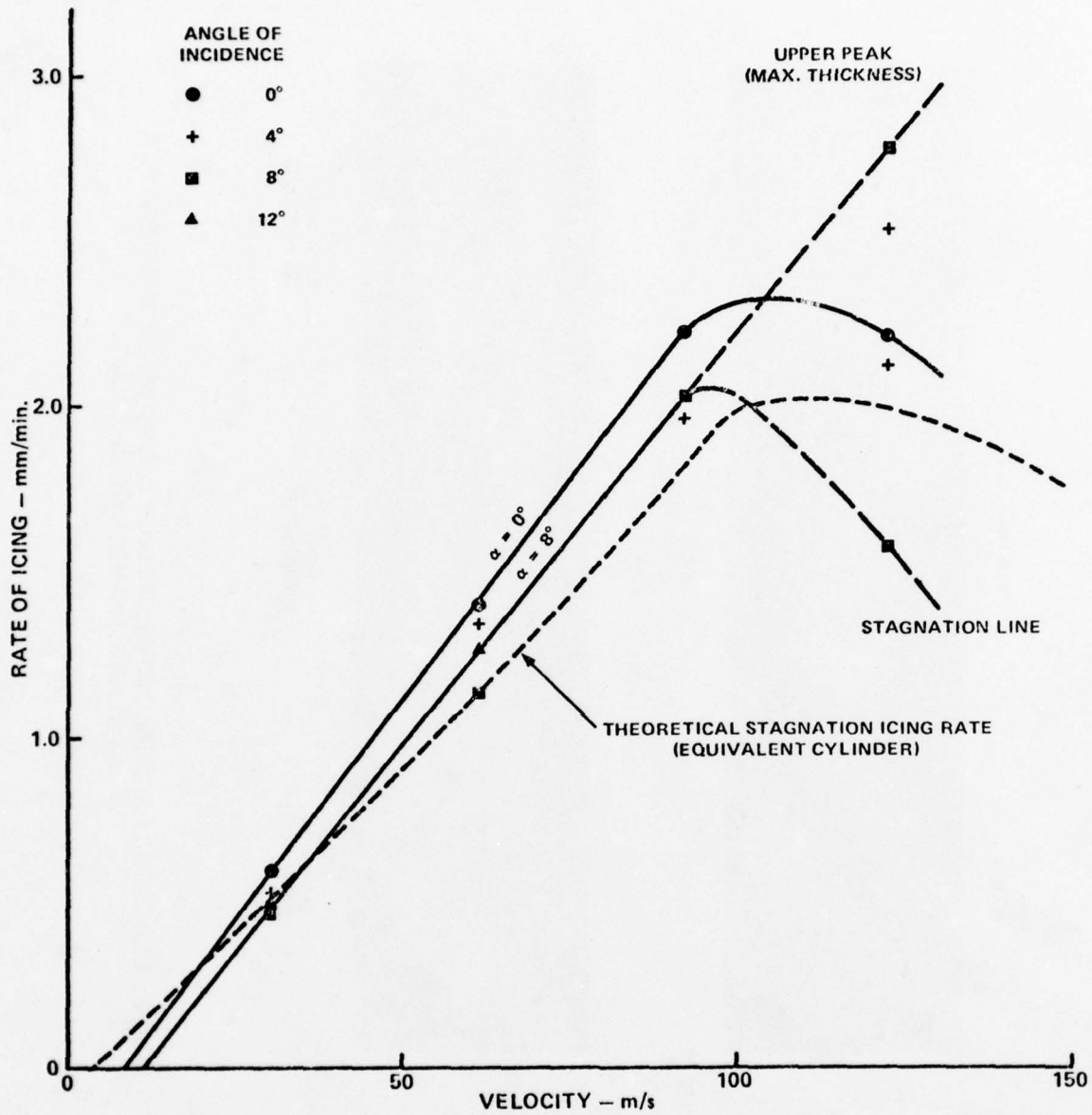

FIG. 6: ICING RATE ON 8.375 INCH (21.27 cm) CHORD NACA 0015 AEROFOIL AS A FUNCTION OF VELOCITY, AT VARIOUS ANGLES OF INCIDENCE, WITH L.W.C. 0.4 g/m³ AND AIR TEMPERATURE - 15°C

T = -5°C

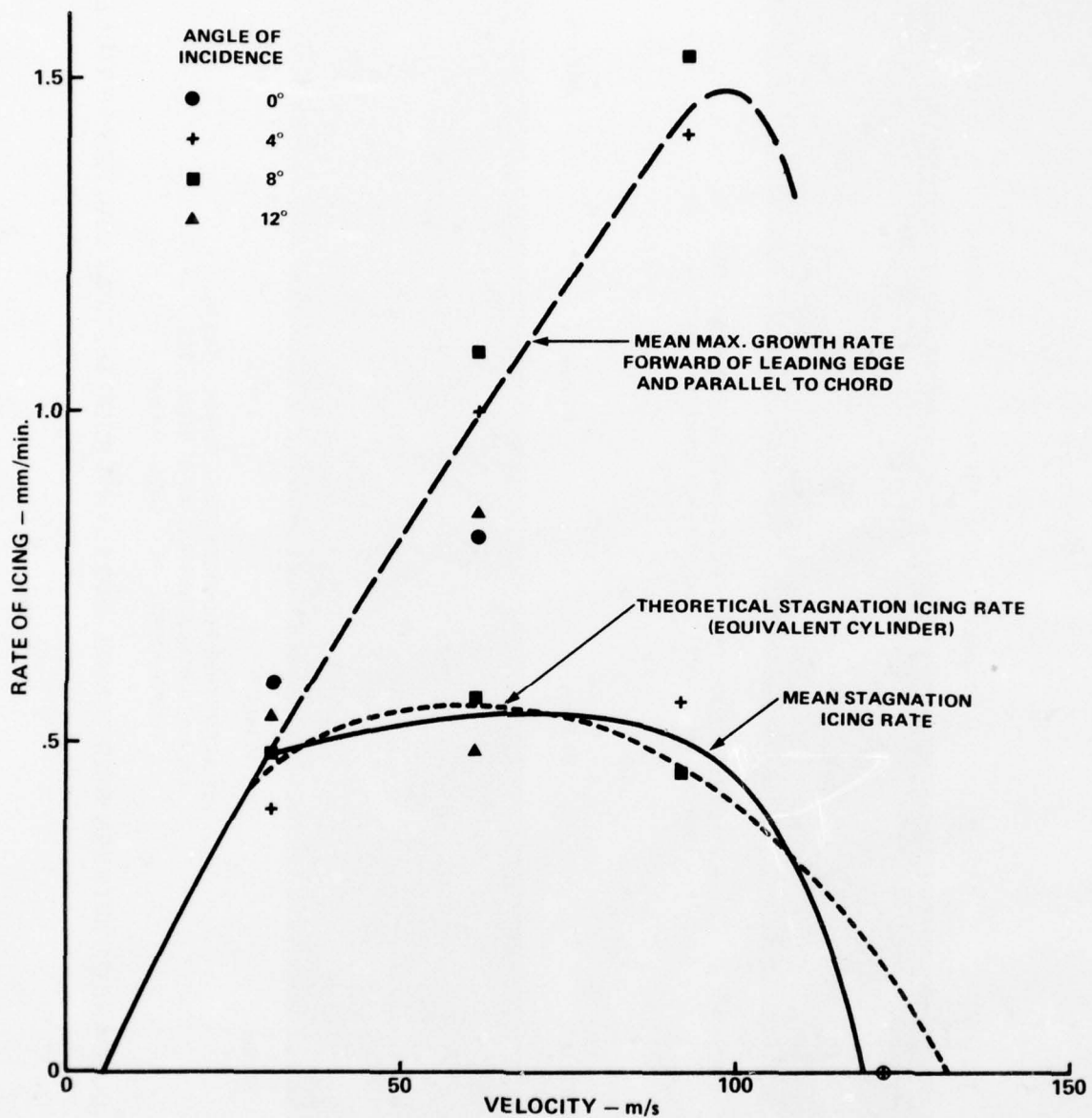
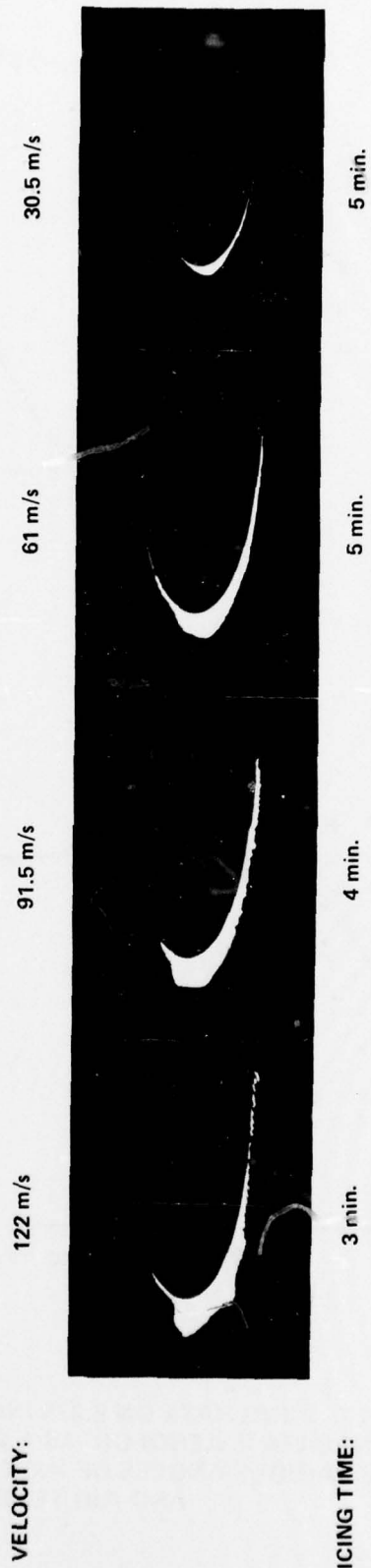

FIG. 7: ICING RATE ON 8.375 INCH (21.27 cm) CHORD NACA 0015 AEROFOIL AS A FUNCTION OF VELOCITY, AT VARIOUS ANGLES OF INCIDENCE, WITH L.W.C. 0.4 g/m³ AND AIR TEMPERATURE -5°C



ICE ACCRETION PROFILES FROM S-55 FLIGHT IN SPRAY RIG
 TEMPERATURE: -14°C L.W.C.: 0.2 g/m^3 ICING TIME: 14.3 min.



ICE ACCRETION PROFILES FROM TUNNEL TESTS
 ON NACA 0015 AEROFOIL AT 8° INCIDENCE
 TEMPERATURE: -15°C L.W.C.: 0.4 g/m^3

FIG. 8: COMPARISON BETWEEN WIND TUNNEL AND FLIGHT ICING TESTS AT LOW TEMPERATURE

SPAN: 100% 95% 88% 75% 62% 50% 37% 24%

VELOCITY: 162 m/s 153 m/s 143 m/s 122 m/s 101 m/s 80 m/s 60 m/s 39 m/s



(a) 14 MINUTE HOVERING FLIGHT AT -14°C AND L.W.C. 0.2 g/m^3
 MAXIMUM ICE THICKNESS = 12.7 mm



(b) 38 MINUTE HOVERING FLIGHT AT -15°C AND L.W.C. 0.2 g/m^3
 MAXIMUM ICE THICKNESS = 31 mm

FIG. 9: EFFECT OF EXTENDING FLIGHT TIME FROM 14 TO 38 MINUTES
 UNDER THE SAME NOMINAL ICING CONDITIONS



ICE ACCRETION PROFILES FROM S-55 FLIGHT IN SPRAY RIG
 TEMPERATURE: -2.5°C L.W.C.: $\sim 1.0\text{ g/m}^3$ ICING TIME: 23.4 min.

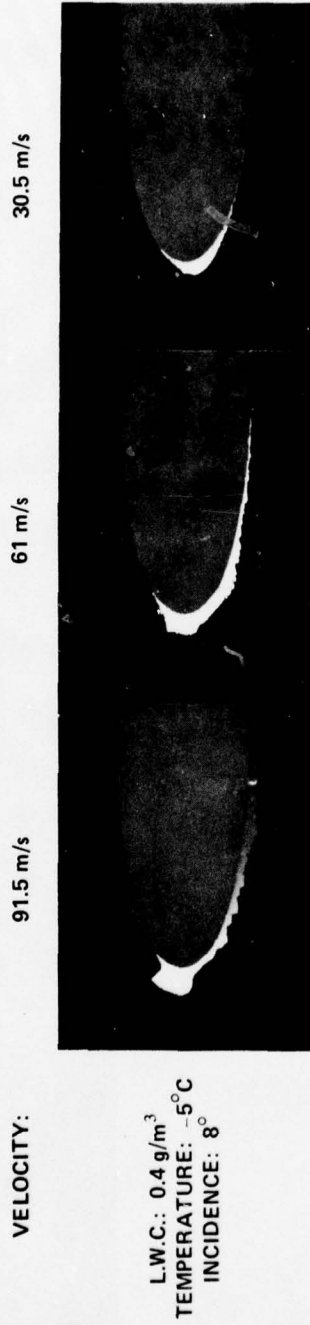

ICE ACCRETION PROFILES FROM WIND TUNNEL TESTS ON NACA 0015 AEROFOIL

FIG. 10: COMPARISON BETWEEN WIND TUNNEL AND FLIGHT ICING TESTS AT HIGH TEMPERATURE

V = 30.5 m/s
T = -15°C
 $\alpha = 4^\circ$

V = 122 m/s
T = -15°C
 $\alpha = 4^\circ$

V = 122 m/s
T = -15°C
 $\alpha = 4^\circ$

V = 91.5 m/s
T = -5°C
 $\alpha = 4^\circ$



(a) L.W.C. = 1.2 g/m³

(b) L.W.C. = 0.4 g/m³

(c) L.W.C. = 1.2 g/m³

(d) L.W.C. = 0.4 g/m³

DROPLET CLOUD ACCRETIONS



(e) L.W.C. = 1.2 g/m³
I.C.C. = 0.7 g/m³

(f) L.W.C. = 0.4 g/m³
I.C.C. = 0.4 g/m³

(g) L.W.C. = 1.2 g/m³
I.C.C. = 0.8 g/m³

(h) L.W.C. = 0.4 g/m³
I.C.C. = 1.4 g/m³

MIXED CLOUD ACCRETIONS

FIG. 11: EFFECT ON ACCRETION OF THE ADDITION OF ICE CRYSTALS TO AN ICING CLOUD

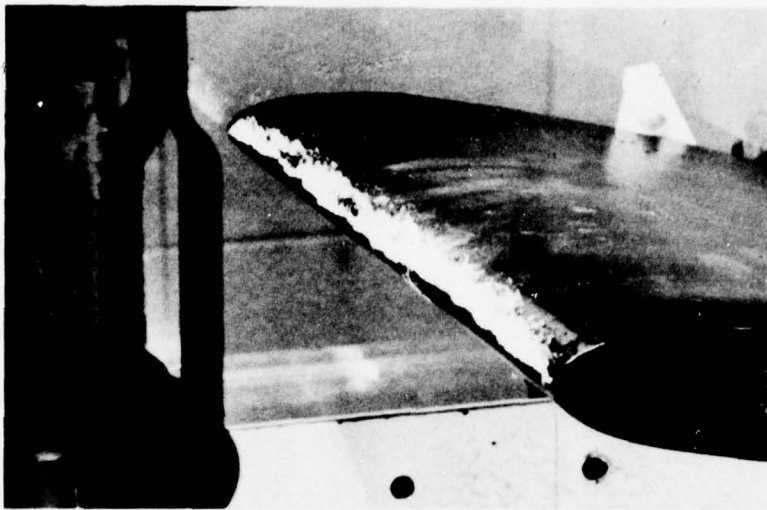

UPPER SURFACE

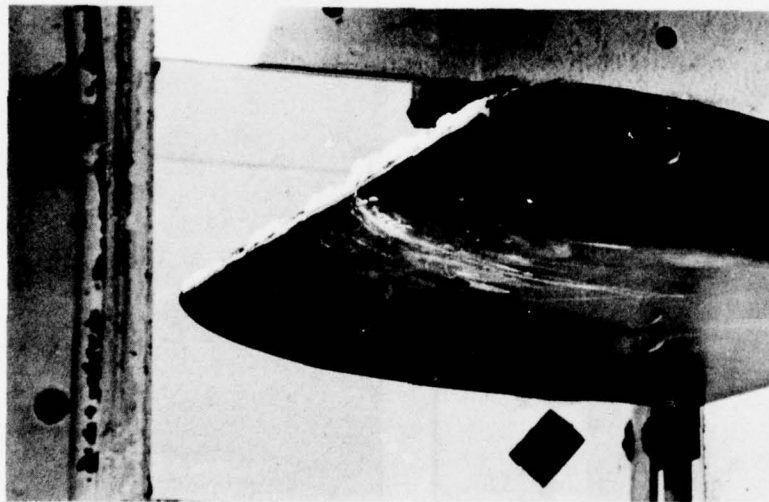

LOWER SURFACE

FIG. 12: UNILATERAL ICE FORMATION

CONDITIONS: $\alpha = 8^\circ$, $V = 122 \text{ m/s}$,
 $T_\infty = -5^\circ$, $\text{L.W.C.} = 0.5 \text{ g/m}^3$,
 $t = 3 \text{ min.}$

AEROPLANE AND ARMAMENT EXPERIMENTAL ESTABLISHMENT
BOSCOMBE DOWN

TECHNIQUES FOR ICING TEST FLYING

G V RAY

PAPER FOR PRESENTATION AT NATO PANEL X HELICOPTER ICING SYMPOSIUM
ON 6 AND 7 NOVEMBER 1978

SUMMARY

This Paper illustrates the UK approach to the instrumentation necessary for the development of rotor blade protection systems, and illustrates how this may be used. The instrumentation includes a rotor head camera capable of viewing all four blades simultaneously, blade lag angle measurements to determine the power absorbed by each individual blade and strain gauge instrumentation to determine the onset of retreating blade stall due to icing. In addition, a tail mounted camera viewing the underside of the blade has been developed. This instrumentation, together with instruments capable of determining OAT and LWC of the icing cloud, enables the behaviour of rotor blade protection systems to be studied and the systems developed and optimised in a systematic fashion. The development can include the study of two different heating patterns on alternate blades in the case of a four bladed rotor.

The views expressed in this Paper are those of the author and do not necessarily reflect the policy of A&AEE.

1 INTRODUCTION This Paper describes some of the specialised instrumentation which has been developed in the UK for the study of helicopter rotors in icing conditions. The development originated during clearance trials with unprotected rotor systems when it became necessary to explain widely different results from apparently identical tests. The instruments carried on the test aircraft to quantify the icing environment were unreliable and at times gave conflicting results. Until 1975 Boscombe Down experience was centred around unprotected rotor systems and is shown in Fig 1. During these trials it became obvious that no worthwhile long term clearances for other than short encounters could be given for the unprotected rotors tested up to that time. Two features which affected future Boscombe Down test philosophy became apparent during the 1973-74 icing season.

The first was that an apparently homogenous icing cloud was very obviously not, as far as icing and its effects was concerned. Fig 2 shows ice grown on the rotors of two Wessex helicopters flying at the same time in the same strata form cloud mass within 10-20 miles of each other. Not only is the ice different in form but its effect on the aircraft was also very different. One aircraft flew for over an hour suffering only minor power increases, while the other was repeatedly forced to vacate the icing cloud due to excessively large power increases occurring within a short time of entering cloud. The second fact, which was revealed by the cameras fitted to the rotor head of the helicopters, was the presence of ice on the rotor blade up to 100% span at temperatures close to 0°C where kinetic heating effects were expected to keep the tips ice free.

One other fact which has also become apparent to Boscombe Down Trials Teams was that there was no readily available substitute for natural icing conditions. The testing of unprotected helicopter rotors in a rig such as the NRC rig at Ottawa did not give a satisfactory representation of the effects in forward flight. After several years of testing in the rig it was found that on numerous occasions it was necessary to vacate the natural icing environment due to reaching previously set power limits.

When in 1974 Boscombe Down were tasked with assessing a passive rotor protection system, utilising a flexible substrate on the rotor blade, these facts coloured the test philosophy. It was a pre-requisite that new instrumentation would be required if a positive result was to be obtained. In order to ameliorate the affects of the variability and non-repeatability of the icing conditions it was decided to fly both protected and unprotected blades on the same rotor. To this end further new instrumentation was required. The instrumentation developed has since been used in the study of an electro-thermal de-icing system by Westland Helicopters Ltd, and it is suggested that it will answer such questions as: how do you know that the rotor would have been adversely affected if there was no protection system, and following on from this when test icing immersions are short due to cloud conditions; how do you know that the protection system is not creating a long-term problem eg by creating run-back in an area where it cannot be removed. The instrumentation package described is expected to be used of course in conjunction with the normal flight parameter records.

2 ROTOR HEAD CAMERA Boscombe Down had for several years used cine cameras mounted on the hub to observe ice formations on the rotor blades. Early trials used black and white film which, while showing rime ice was not capable of showing glaze ice due to the highlights on the blade. Even with colour film it was not easy to interpret the picture and determine the extent of ice as can be seen from Fig 3 which shows a Wessex rotor blade in cloud at a temperature of -3°C with ice clearly visible to 80% radius, in its original form the ice is

6 ICING INSTRUMENTATION Once it was appreciated that spray rig testing could not duplicate the flight conditions under which the helicopter normally operates, it was necessary to mount instruments capable of measuring the icing conditions being experienced during natural icing flying. Early Boscombe Down icing trials showed that the ice detectors and severity meters then available were not able to give reliable information through the spectrum of icing conditions.

The instruments which have given the most consistent information in Boscombe Down icing trials to date have been the NGL hot rod and its offshoot the Boscombe Down Vernier Accretion Meter described by Booker and Barlow. However, on some occasions the hot rod was unable to provide prior warning of the severity of the icing conditions and the aircraft was forced to vacate the cloud with only a light frosting of ice on the Hotrod. Nevertheless in the absence of better instruments these two devices were the only devices available which did not give obviously inconsistent results.

The Paper by Booker and Barlow describes the instruments currently available, and the trials by Westland Helicopters with their Wessex last winter showed that the NRC-Leigh instrument and the RAE rotating disc gave promising results. They enabled the aircraft to seek out and remain in icing conditions, since they continued to function and gave consistent results. In particular they were calibrated in an icing tunnel in terms of liquid water content, LWC, which is one of the parameters in the proposed icing atmosphere standards. One feature of all icing instruments is that their position on the aircraft can affect the results obtained, and it is essential that they are mounted in as close to free-stream conditions as possible.

Apart from LWC instruments an accurate outside air temperature OAT instrument is also required. The chosen instruments needs a high sensitivity and a rapid response. Boscombe Down use a sensor developed by the Instrumentation Group from a commercial sensor and this is coupled to a Tinsley Digital Indicator. The accuracy is believed to be better than $\pm 0.2^{\circ}\text{C}$ in icing conditions.

7 USE OF THE INSTRUMENTS All of the instruments so far described have been developed for two reasons. Firstly, because icing conditions are seldom constant for long enough periods to determine whether a protection system will provide adequate protection in the long term and secondly to enable an assessment of protection systems to take place in the absence of a detailed knowledge of the test conditions. In order to fulfill both these requirements it is necessary to know not only where the ice is and how it affects individual rotor blades but also what is the effect on the helicopter as a whole. It is here that mention should be made of the testing philosophy adopted in the UK which is based on flight in natural icing conditions and by this is meant flight in actual icing. Icing does not necessarily take place in clouds at OATs below zero and meaningful results can only be obtained if icing is known to be taking place, hence the requirement for icing instrumentation on the test aircraft.

Once icing conditions are encountered the UK technique is to attempt to maintain constant height and speed. This of course means that in order to measure the degradation in performance and to safeguard transmission limitations an accurate torque meter is an essential piece of equipment, since engine calibrations are not sufficiently flexible for rapid determination of the power changes in flight. If speed and height are maintained constant the variable which quantifies a change in performance of the rotor is a change in power and collective pitch required. If the chosen speed is well above the minimum power speed then in the event that power limits are reached two courses of action are available, either height may be reduced

or speed may be reduced and height maintained. However, if the alternative method of flying with a constant power setting is used and the air speed or altitude allowed to change continually it is more difficult to determine the degradation due to the non-steady flight conditions. It is possible that eventually the situation could arise where the aircraft was descending at minimum power speed and it was impossible to maintain height. In addition to straight and level checks of the loss of performance of the helicopter it is essential to confirm that the manoeuvring capability is still retained and hence as a minimum turns up to the IMC bank angle limits are required at the proposed cruising speed. On one occasion with an unprotected rotor, while making such a manoeuvre a partial loss of control was experienced due to retreating blade stall during the turning manoeuvre.

The initial concept of the instrumentation package was centred around what has become known as the 2 x 0 configuration ie a rotor system with two protected blades and two unprotected blades. A comparative approach was used because natural icing conditions are not easy to find, are often of limited duration and are highly variable. The package described enables such a comparison to be made because it is collecting information from all four blades of the rotor individually and not from the total rotor system. It is not strictly necessary to monitor all four blades but only one of each pair, such is the nature of natural icing trials flying that the doubling up of parts of the instrumentation by monitoring all four blades is extremely useful. The instrumentation as described also contains some elements of redundancy by doubling up on both the cameras and strain gauge information and again it is useful to have confirmatory evidence from different sources.

The cyclic de-icing system with pairs of blades being de-iced alternately enables a comparison of a protected blade and an unprotected blade to be made when the system is first energised in icing conditions and as such could be described as a 2 x 0 system at that instant. However, the instrumentation package would also enable comparative trials of two different systems to be run on the same rotor at the same time ie a 2 x 2 system. ; In practical terms such a course with an electro-thermal system might involve considerable extra complexity in control gear and perhaps different blade heater mats. With a single system it should be a simple matter to arrange for one pair of blades to be switched out to give a 2 x 0 system until such time as the second pair of blades might have to be de-iced; If for instance vibration became severe due to the unbalanced blade protection systems. The 2 x 0 and 2 x 2 concepts are almost essential features of any development programme in order to make optimum use of natural icing conditions.

The two most likely causes of long term rotor degradation are firstly the formation of runback ice due to too much heat being applied or secondly incomplete shedding due to insufficient heat. It is suggested that the instrumentation package proposed will enable the cause to be determined.

believed to extend to 100% radius. The foreshortening of the blade tip is due to the low viewpoint of the camera, only some 200 mm above the blade root. Any increase in the height of the viewpoint would be beneficial, but to mount the camera itself higher up would involve considerable difficulties. The proposed solution was to use a periscope, and in view of the fact that it was intended to fly a rotor with unprotected and protected rotor blades it was desirable to photograph at least one of each type of blade. It was easy to photograph all four blades by placing the camera on its back pointing at a surface silvered pyramid reflector. However, if the picture quality was to be maintained a larger film size than the 16 mm used previously was required. Fig 4 shows the latest version of the rotor head camera which uses a modified F95 low level reconnaissance camera. The camera gives a 70 mm square picture, and the surface silvered pyramid increases the viewing height to approximately 750 mm. In order to stop any blade motion an exposure time of 1/800 seconds is used, together with a small aperture to provide an adequate depth of field, remembering that the closest part of the blade is approximately 2 m from the camera while the tip is 10 m away. High speed film is used and the processing adjusted to approximately double the effective film speed. Fig 5 shows a frame obtained from this camera, the improvement in picture definition compared with the previous camera is very marked. Note the expansion of the tip area given by the increased viewing height. The definition and overall picture quality are such that areas where ice is present be it leading edge or run back can be seen. One point to note is the time counter in the centre of the frame which enables the film to be correlated with all other records taken during the flight. The final version of this camera which will be used in the coming winter has an automatic iris to give the correct aperture, and hopefully will remove the need for special film processing. At present the aircrew carry an exposure meter, and the film processing is adjusted to give the optimum picture for the parts of the flight that are of interest.

3 TAIL CAMERA The rotor head camera looks at the top surface of the blade and in order to obtain information about the under side a further high speed camera mounted at the rear of the aircraft has been developed. It may well be argued that the under side is not the critical area and while this is undoubtedly true, the aim behind the camera installation was to investigate with more accuracy the extent and form of the ice on the leading edge at the tip. Initial trials of the camera itself took place in Ottawa 1974 with a ground based camera and the aircraft flying low over a snow-covered surface the results were impressive (Fig 6). The next step was to mount the camera on the aircraft, the only suitable position being on the side of the tail cone viewing the retreating blade. Trials in 1975 showed three problem areas. Firstly, with a free running camera the blade was not necessarily in a suitable position being either too close and distorted due to the speed of movement or too far away to provide useful information. Secondly, when used in cloud the illumination of the blade was such that ice could not be seen. Thirdly, when the camera was used there was no means of relating the picture taken to the flight conditions. These problems have been overcome, the last being the easiest. The other two requiring considerable ingenuity and effort expended to produce worthwhile results.

The present camera installation comprises another modified F95 camera similar to the rotor head camera, mounted on the side of the tail cone. The camera has an f2.8 lens which is the largest that can be used without loss of picture definition. It has a focal plane shutter with an exposure time of 1/30 ms, which is triggered by a radar unit sensing the passage of a rotor blade over the tail cone. A control unit in the aircraft operates the camera when the blade is in the optimum position. The camera itself provides a signal to operate a flash tube, which to avoid back scatter effects is mounted forward of the camera. The control unit arranges that a picture of each of the four blades is taken following every camera event. Fig 7 shows such a sequence of four blades. The dots between the pictures are the binary

time code, which ties in the picture in the same way as the clock in the rotor head camera. One fact which is not obvious is that although the camera would allow some small latitude in blade position, the illumination would not. The beam from the photo flash is narrow in order to provide the necessary illumination and hence it only illuminates a very small area, the latitude on blade position is approximately \pm 300 mm at the blade tip. Fig 8 shows a Wessex aircraft fitted with both the rotor head and tail-boom cameras.

4 LAG ANGLE POTENTIOMETERS Potentiometers were fitted to the lag hinges of the aircraft used for the trials of a passive ice protection system, in which two different standards of blade were fitted to the same rotor, since a method of determining the power absorbed by individual blades was required. The total power required by the main rotor can be derived either from a torquemeter or from engine parameters if calibrated engines are available. Preliminary trials (Reference 1) made at Boscombe Down confirmed that for a non-iced rotor blade the mean lag angle of the rotor blades was proportional to the power absorbed by the rotor, hence it followed that changes in individual mean lag angle reflected changes in power absorbed by individual blades. Fig 9 shows a typical calibration, the relationship with torque being a linear and virtually independent of flight speed or condition, one variable which affects the calibration is rotor speed. Recent trials (Reference 2) with simulated ice confirmed that the measurements of lag angle could indicate differences between blades with differing amounts of degradation. With a cyclic de-icing system in which pairs of blades are heated at the same time it was expected that as the system cycled the results similar to Fig 10 should be obtained. Such confirmation was obtained during last winter's trial of the Wessex system in Denmark.

5 CONTROL ARM STRAIN GAUGES Any increase in the area of the retreating blade stall will cause an increase in vibration level together with an increase in the loads in the pitch change arms, which would seriously reduce the fatigue lives of these components. For many years an essential instrument in Boscombe Down icing trials has been a star load indicator. This consists of strain gauges on the fixed star which reflect the loads during the retreating part of the rotor disc. The loads are oscillatory in form and the strain gauge signals are processed electronically to provide an indication on a meter to enable the test aircrew to respect flight safety limits. However, when used with a cyclic de-icing system it must be remembered that the frequency of the peak signals will be at two per rotor revolution for a four bladed rotor and since the electronic circuit is not designed for this frequency the indications will be grossly in error. For this reason the unprocessed stationary star loads are also recorded throughout the flight.

Strain gauges mounted in individual pitch change rods provide a unique indication of the behaviour of individual blades, when combined with an azimuth marker much useful information on the effect of ice on the rotor characteristics can be obtained. In particular the efficiency of de-icing systems can be studied by comparing the wave forms in icing as the system operates. Typically the rotating star trace develops a spike as the ice builds up and the stalled area of the disc increases due to the decreasing C_L max resulting from the ice, as the de-icing system operates the spike should disappear and the wave form should approach that in clear air. Such behaviour has been observed in trials. Modification of the wave form from its clear air value would indicate either inefficient de-icing, or that the de-icing system itself is causing a problem by perhaps causing run back ice to form.

8 END WORD What has been described in this Paper is a set of instruments and cameras that enable systematic development of rotor protection systems to take place in the absence of constant and controlled icing conditions. Fig 11 shows the equipment deemed necessary on a rotor test vehicle. This Paper is not intended to imply that further instruments to quantify the icing environment are not required, but merely emphasises that such instruments do not by themselves provide a complete answer. Indeed the instrumentation flown to date has only emphasised the need for such techniques as are described in this Paper in order to make use of the conditions which nature provides. Although throughout this Paper emphasis has been centred on comparative testing the instruments described can and should be used in any de-icing system development trial whether comparative or not. Without their use it is difficult to envisage a high level of confidence for the operation of a de-icing system unless very extensive trials are carried out. Since icing trials are invariably limited in time it will probably take many years to accumulate evidence for clearance. Without instrumentation to measure the icing environment in which tests have been made and a thorough knowledge of the atmosphere there must, of course, be an element of risk, whether or not the instrumentation and test techniques proposed are adopted. It is confidently believed that the risks can be considerably reduced if the major part of the philosophy presented in this paper are followed.

Performance Division
A&AEE Boscombe Down
4 October 1978

| SEASON | No. OF NATURAL ICING SORTIES IN WHICH ICING WAS ENCOUNTERED | No. OF SORTIES IN WHICH LIMITING CONDITIONS WERE REACHED |
|----------|--|---|
| PRE 1970 | 39 | - |
| 1970/71 | 20 | 1 |
| 1971/72 | 7 | 1 |
| 1972/73 | 62 | 3 |
| 1973/74 | 60 | 6* |
| 1975 | 15 | 6* |
| TOTAL | 203 SORTIES 111 HOURS IN ACTUAL ICING | 17 |

* INCLUDES SORTIES IN WHICH LIMITING CONDITIONS WERE REACHED ON MORE THAN ONE OCCASION

FIG. 1 BOSCOMBE DOWN EXPERIENCE IN NATURAL ICING CONDITIONS

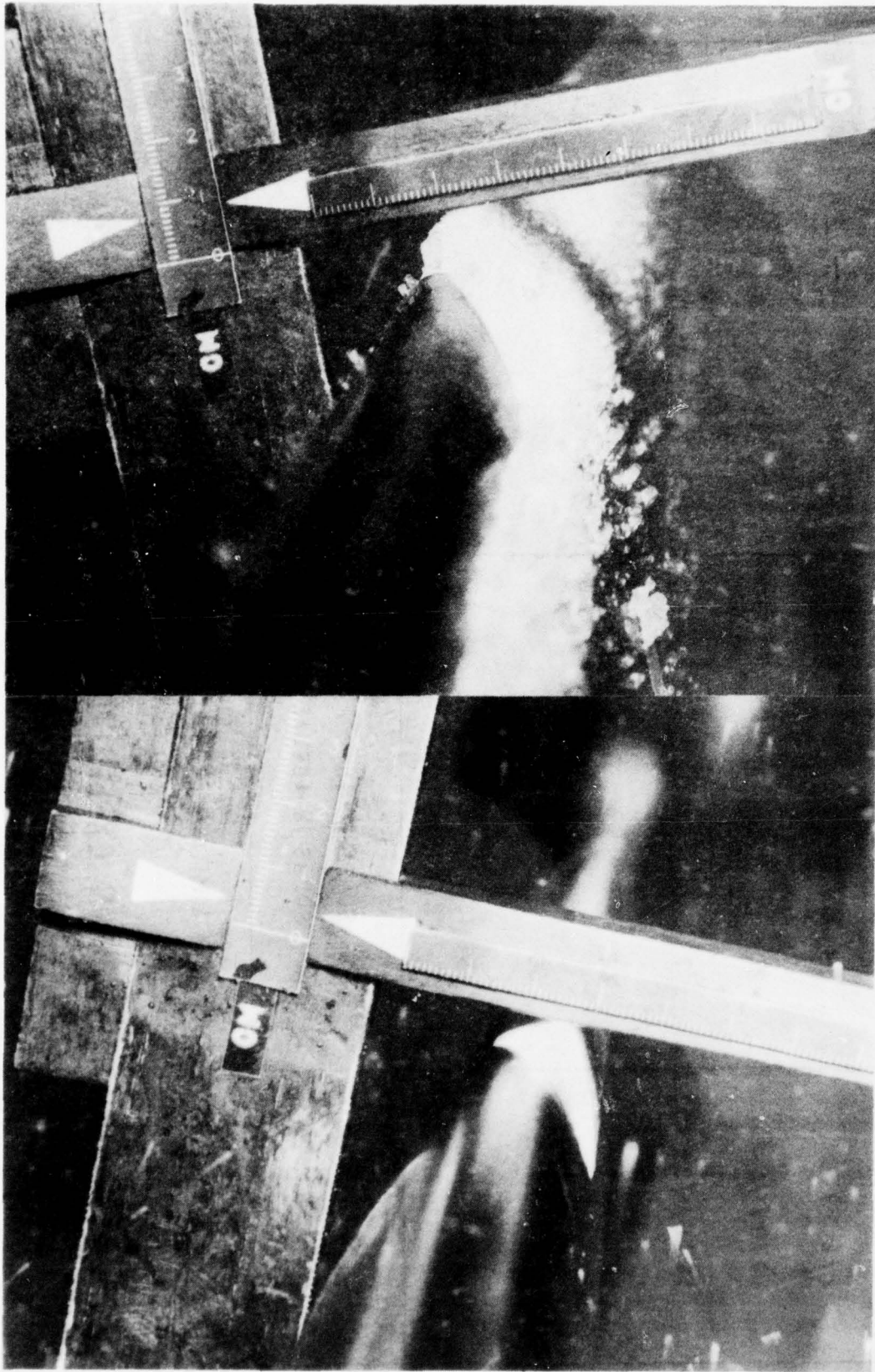

FIG 2 Ice Accreted on the Rotor Blades of Two Identical Aircraft Flying in the same cloud mass at the same time 10 to 15 miles apart

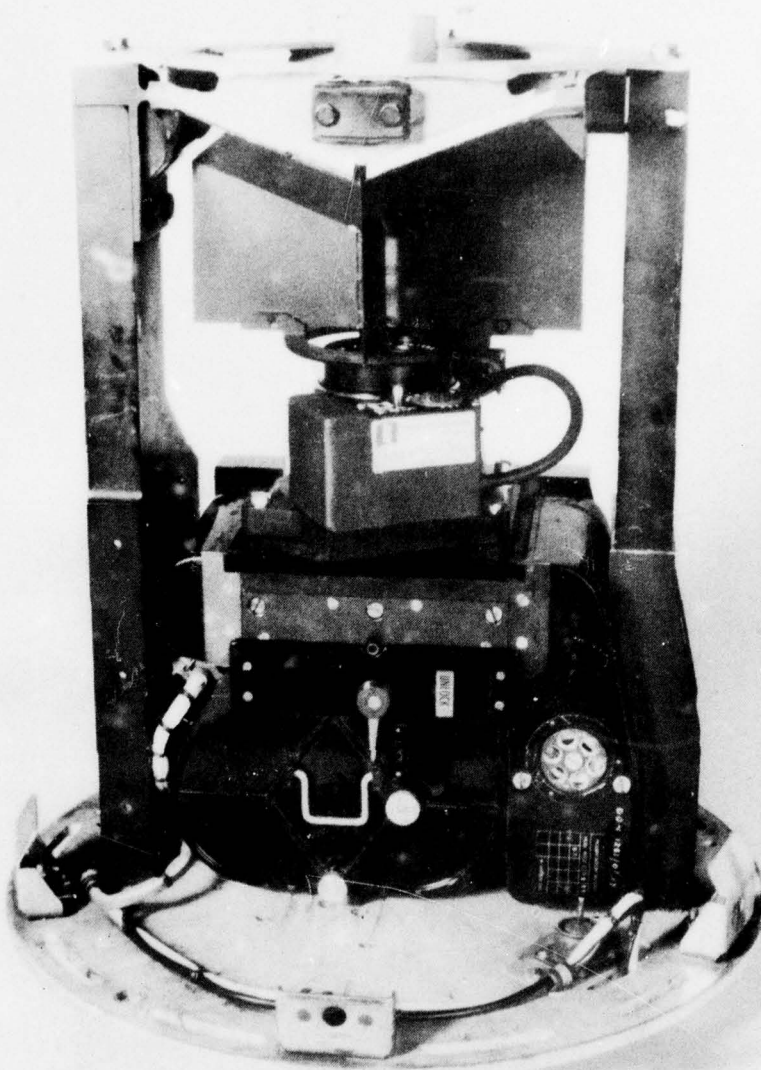

FIG 4 70mm Rotor Head Camera Installation

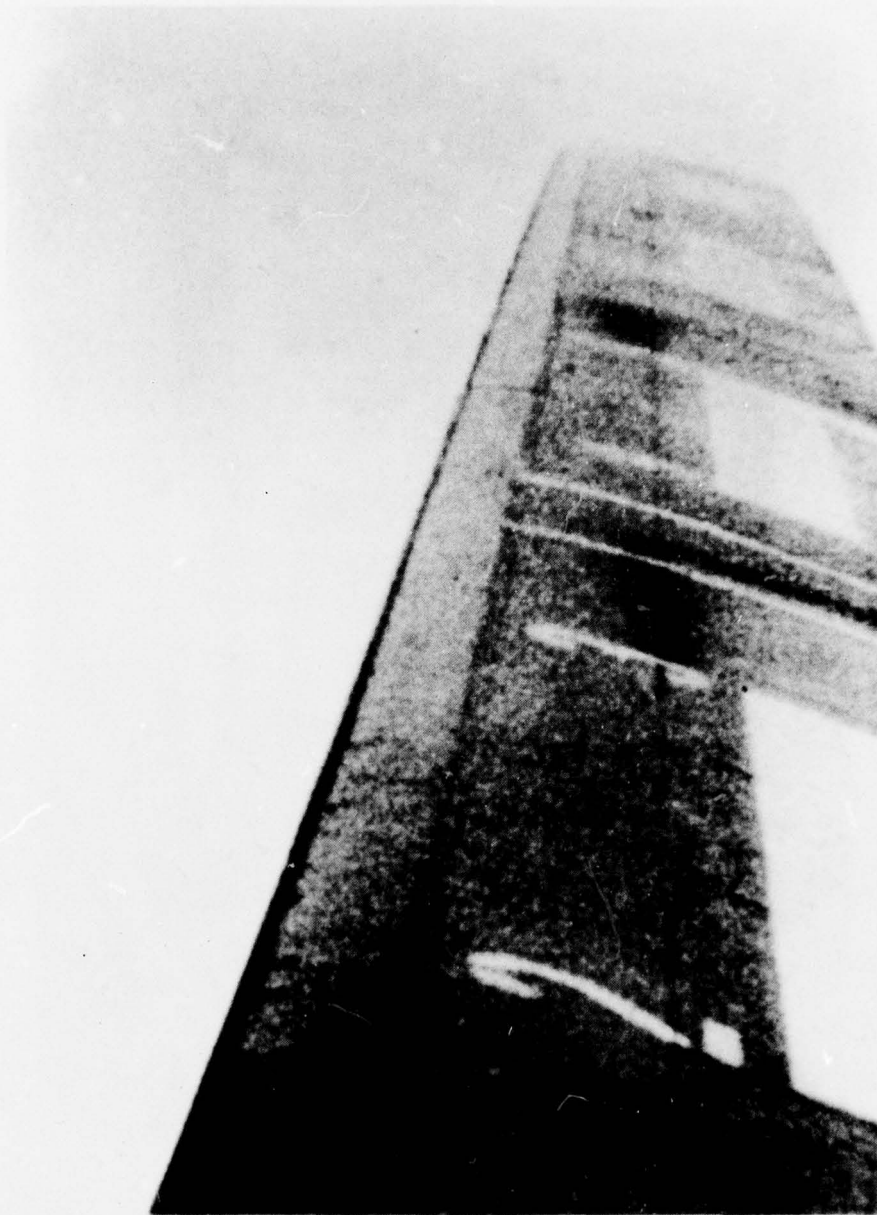

FIG 3 Wessex rotor blade in natural icing at -3°C

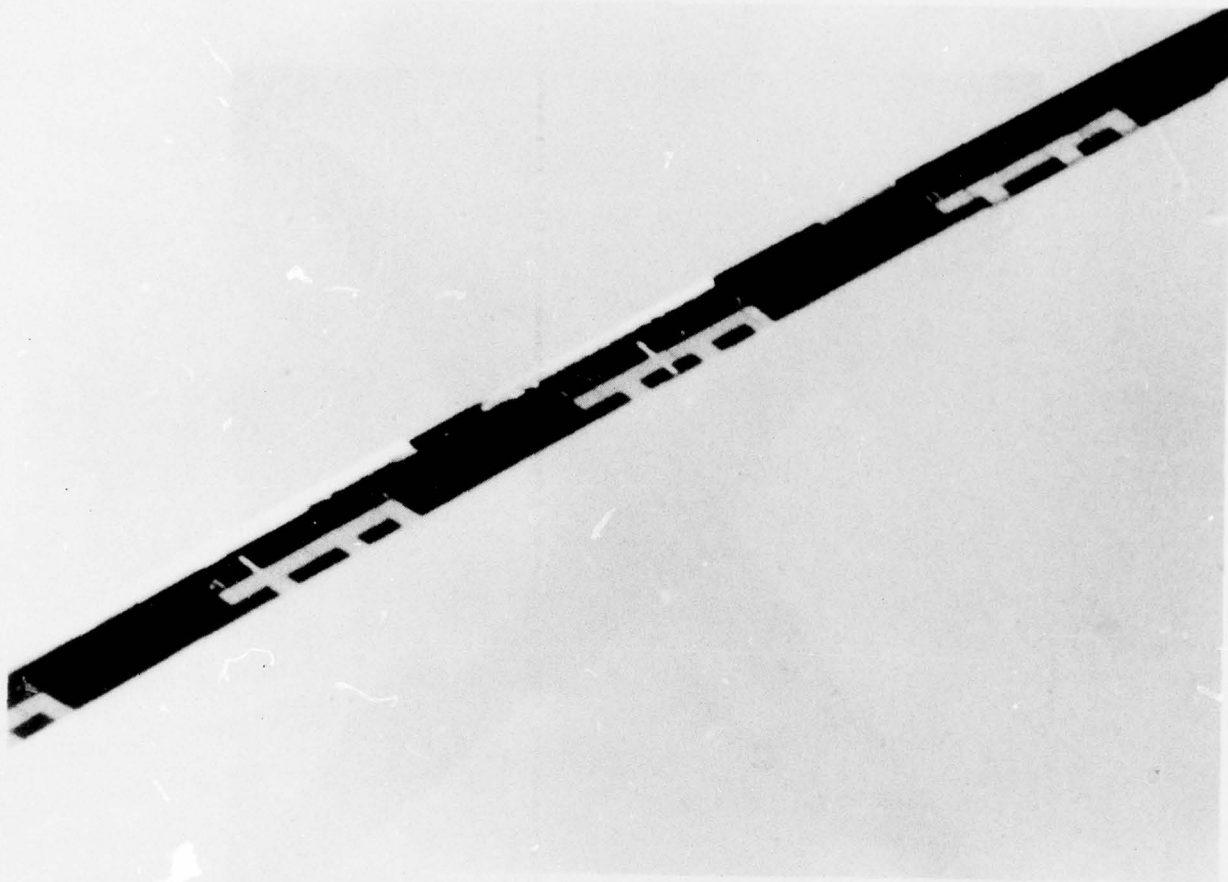

FIG 6 Frame from ground based - high speed camera
showing ice on the blade



FIG 5 Frame from 70mm Rotor Head Camera
showing ice detaching from 1 blade

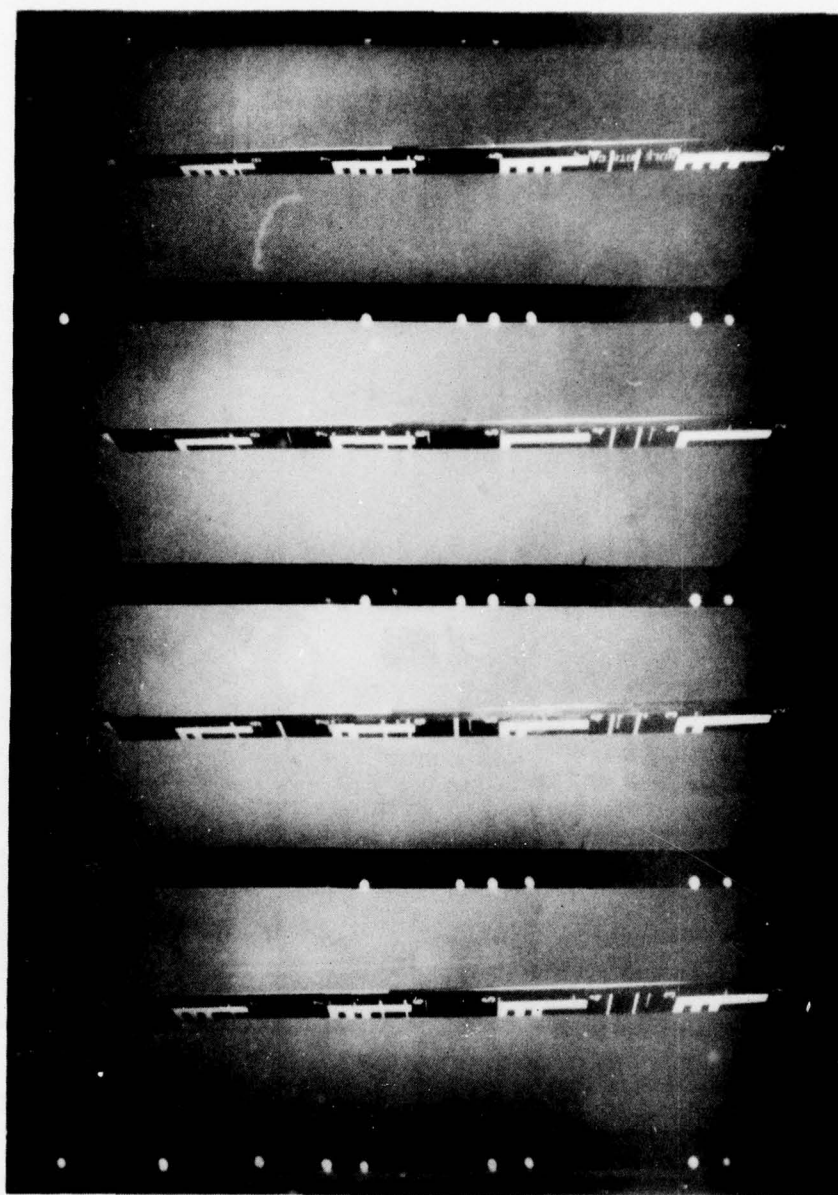

FIG 7 Sequence of 4 Blades from Tail mounted camera



FIG 8 Westland Wessex helicopter fitted with Rotor Head and Tail Boom Cameras

- × LOW SPEED
- LEVEL FLIGHT
- CLIMBS AT 80 KNOTS

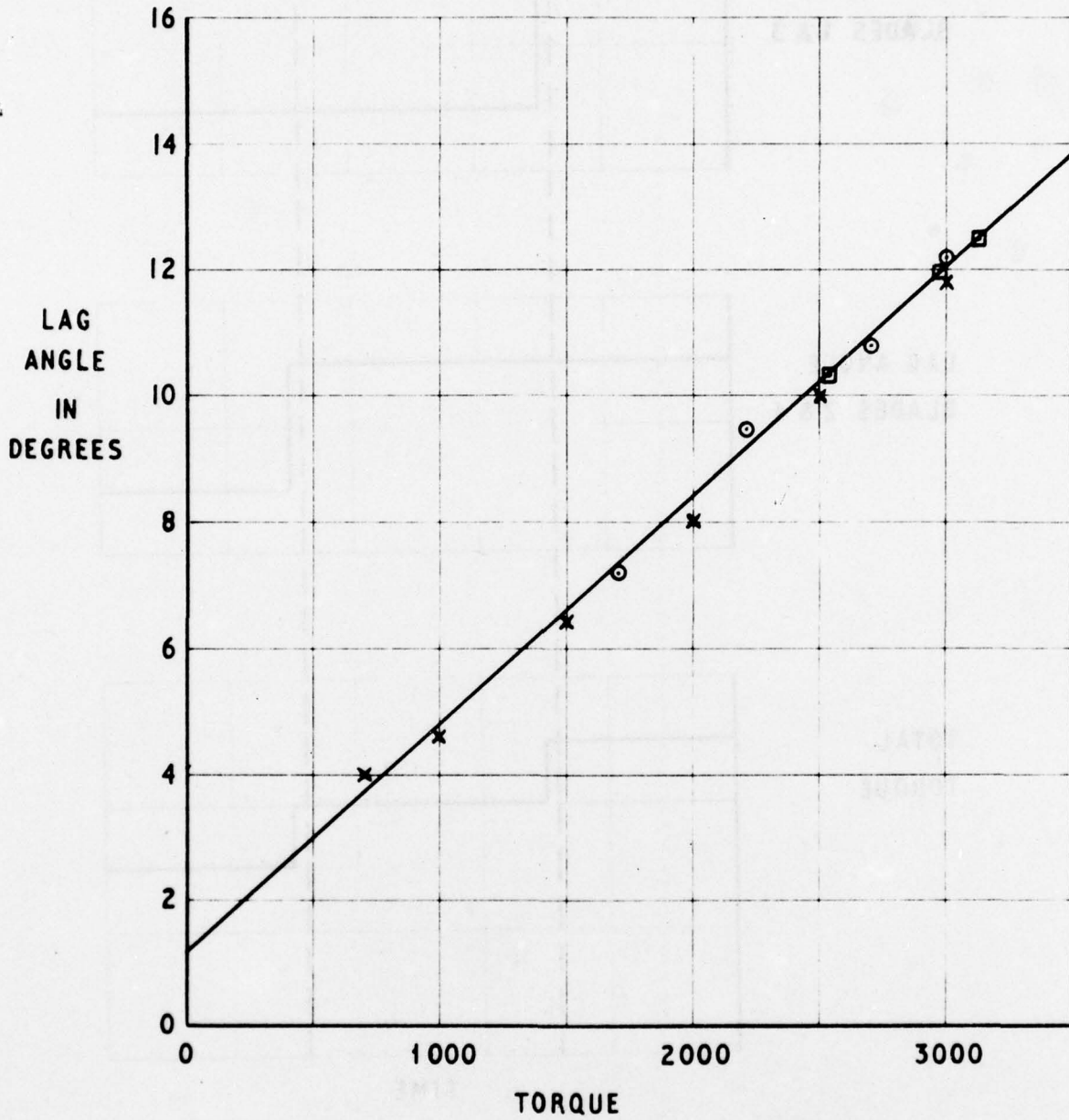

FIG. 9 TYPICAL LAG ANGLE CALIBRATION.

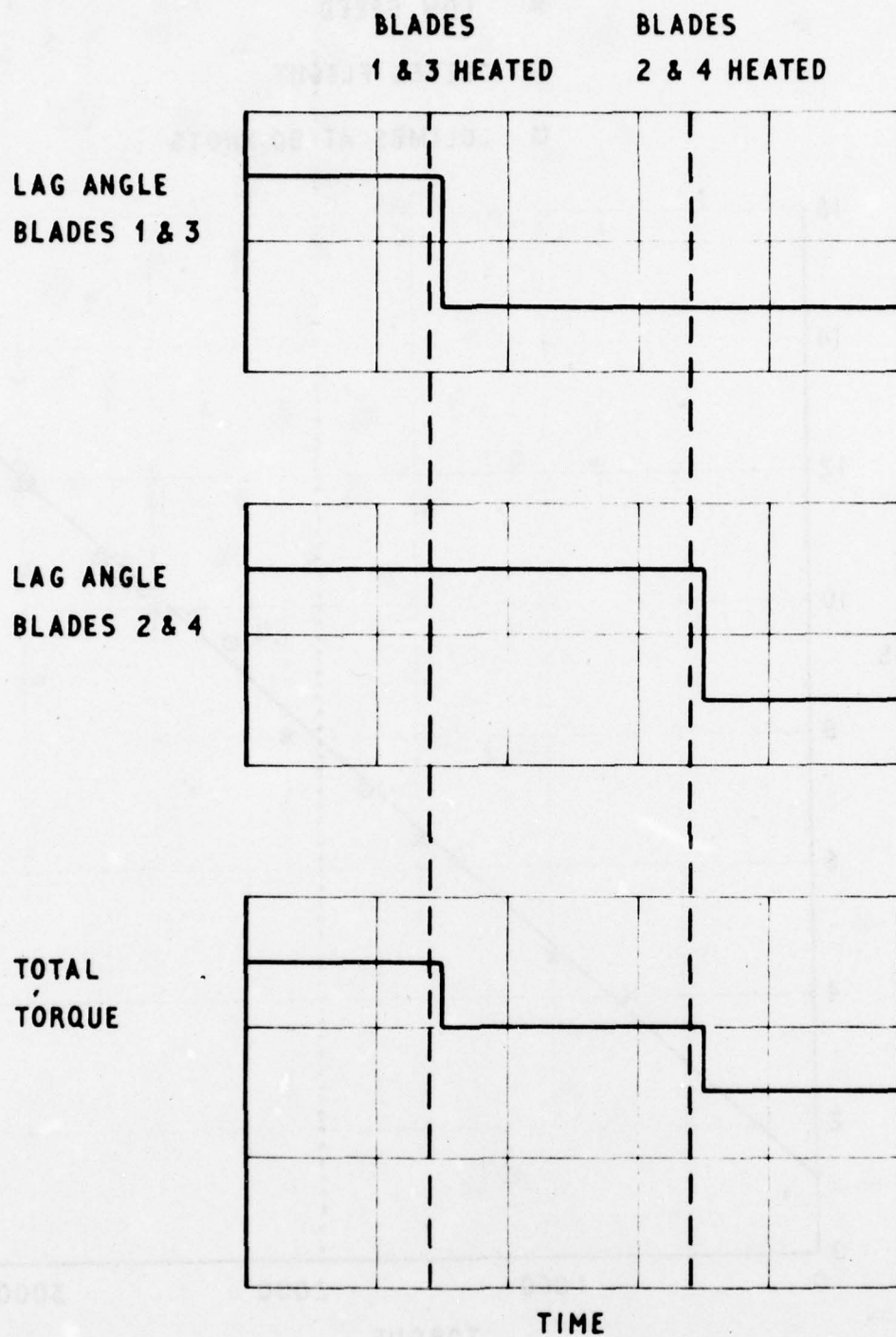

FIG. 10 LAG ANGLE BEHAVIOUR EXPECTED WITH A CYCLIC DEICING SYSTEM.

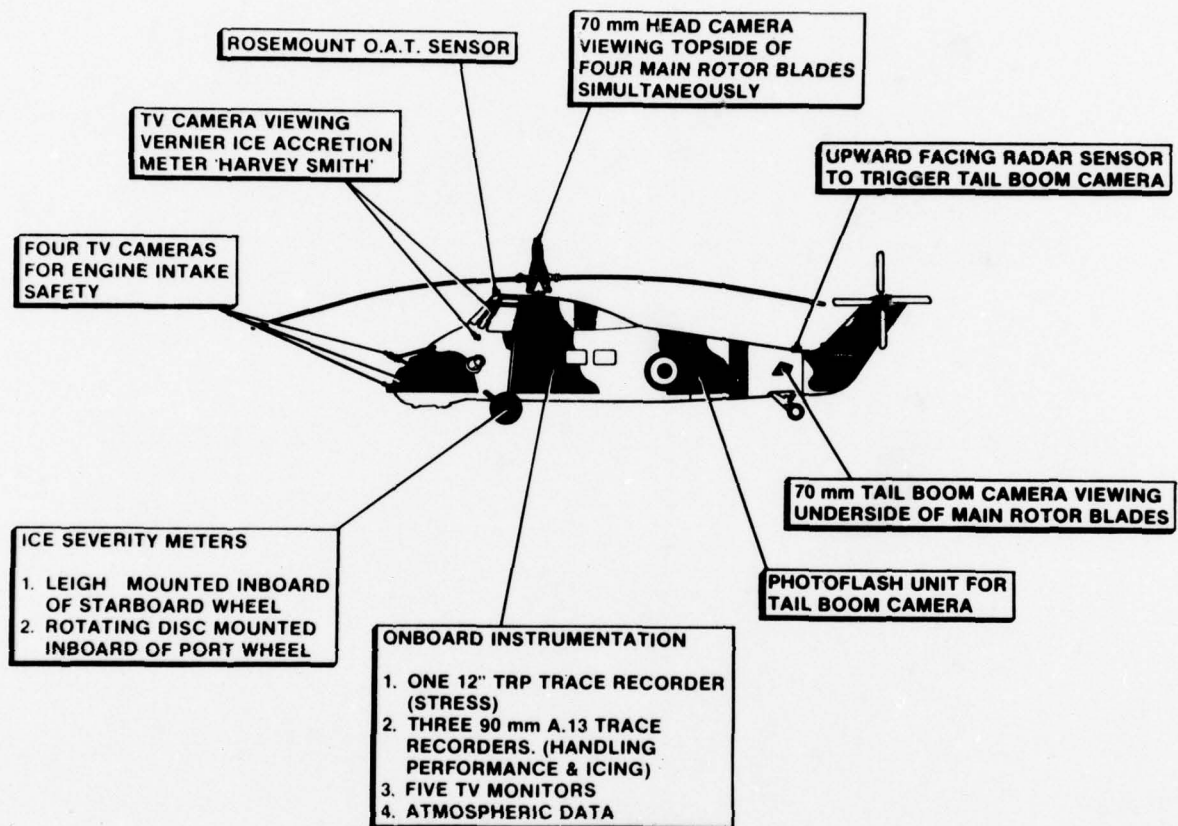

FIG 11 The Instrumentation package proposed for deicing system development trials

HELICOPTER ICING SPRAY SYSTEM

**Alan R. Todd
Lt Colonel, US Army**

**United States Army Aviation Engineering Flight Activity
Edwards Air Force Base, California 93523**

**Presented at the Symposium on Helicopter Icing
6-7 November 1978**

**PRECEDING PAGE NOT FILMED
BLANK**

ABSTRACT

The United States Army has long been devoted to qualifying its helicopters for intentional flight into icing conditions. In 1973 the US Army Aviation Engineering Flight Activity (USAAEFA) developed a helicopter icing spray system (HISS), which is used to create a controlled in-flight icing environment in which to test helicopters. In the winter of 1973-74, the HISS was used in tests of the AH-1G, UH-1H, and CH-47C helicopters. Spray system shortcomings discovered during these tests led to modification of the HISS in 1975. In 1976, USAAEFA conducted icing tests of two prototype utility tactical transport aircraft systems (UITAS) which were in competition for the Army's replacement utility helicopter. During the 1977-78 icing season, the HISS was used to evaluate two ice phobic compounds applied to rotor blades of a UH-1H. The current HISS configuration consists of a CH-47C helicopter equipped with an 1800-gallon unpressurized water tank and two spray booms 60 and 25 feet wide located 20 and 25 feet below the aircraft, respectively. The booms contain provisions for a sufficient number of atomizing spray nozzles to create a cloud approximately 60 feet wide and 12 feet deep at the center. Current HISS capabilities in terms of airspeed, altitude, cloud liquid water content, and spray duration per flight, make the HISS a valuable tool for helicopter icing qualification as well as research and development of anti-ice/deice equipment. Future HISS improvement plans to better simulate the natural environment include reduction of the cloud mean droplet size.

The United States Army has always had an interest in an all weather capability for its helicopters and as early as 1955 Army helicopters were being flown in instrument meteorological conditions (IMC). By today's standards, these aircraft were poorly equipped for instrument flight; however, a new dimension was added to the tactical capability of the helicopter. During the 1960's, the changing tactical scene for Europe precipitated a reexamination of the helicopter's capability and, specifically, the helicopter's ability to operate in an icing environment. Since icing research had proceeded slowly in the United States after 1955, very little expertise and test equipment was available to test helicopters. Fixed wing airborne tankers were available, but their airspeed range and cloud size was not adaptable to the helicopter.

The US Army developed the helicopter icing spray system (HISS) for use as an airborne tanker for in-flight icing of helicopters in a "controlled" environment. The HISS was qualified by the US Army Aviation Engineering Flight Activity (USAAEFA) during the summer of 1973 at Edwards Air Force Base, California, and utilized at Fairbanks, Alaska, and Moses Lake, Washington, during the 1973-74 winter to evaluate the AH-1G, UH-1H, and CH-47C. This effort resulted in identifying and documenting the classic problems of an unprotected rotor blade in an icing environment, plus shortcomings of the HISS. The original configuration of the HISS was used once more during the winter of 1974-75 with the first flights of the UH-1 with the Lockheed ice protection system (electrothermally heated rotor blades).

The classic problems found in the 1973-1974 tests of three helicopters without ice protection systems were:

1. Severe vibrations caused by asymmetric shedding of ice from the main rotor blades.
2. Obscured forward field of view when the test aircraft did not have heated windshields.
3. The inability to maintain safe autorotational rotor speed with ice in excess of 3/8 inch on the main rotor blades.

The unanimous conclusion for each of these three tests was that the helicopters did not possess the capability for sustained safe operation in an icing environment. Natural icing tests of the UH-1H in 1974 substantiated the classic problems and overall conclusions arrived at during artificial icing tests even though precise correlation between HISS results and natural icing results was not possible. A major problem in this correlation effort was the inconsistency of the natural environment.

Shortcomings of the original HISS configuration included:

1. Inadequate cloud size. The shallow cloud depth precluded icing the fuselage and main rotor simultaneously.
2. Light to moderate turbulence within the cloud, which could mask vibrations caused by asymmetric shedding or could cause ice shedding which might occur prematurely to that in the natural environment.
3. The rotor downwash caused by the CH-47 resulted in a test aircraft power-required increase equivalent to a 500 to 1000 foot per minute rate of climb.
4. Nonuniform liquid water content (LWC) distribution resulted, since the spray from the nozzles did not overlap and mix properly.

5. Excessively large water droplets were generated by the HISS. These were of such size that the cloud more closely approximates a cumulonimbus cloud.

In spite of the difficulties observed with the HISS during this first icing encounter, the significance of being able to ice three separate aircraft and obtain considerable data within one icing season made the effort and money well spent. Additional advantages of testing with the HISS versus the natural environment were safety related. The icing conditions could be precisely controlled within the limits previously discussed. The environment could be easily entered and exited, and a controlled buildup in icing severity could be accomplished. A typical icing sequence would involve initially locating the desired temperature and then taking a trim power-required reading in the test aircraft prior to entering the icing cloud behind the CH-47. After a prescribed interval in the cloud, at the desired LWC, the aircraft would exit the cloud, and having taken fuel burnoff into consideration, take another power required reading and make an assessment of what torque increases existed as a result of ice accretion and what autorotational degradation existed. In addition, the chase aircraft was in a position to observe possible critical ice buildups. This procedure could be repeated at time intervals that were considered prudent until tests were discontinued due to exceeding established limits, or the HISS water supply was expended, or an asymmetrical shed created severe vibrations. This sequence of test is applicable to helicopters with unprotected blade systems. For helicopters with rotor blade ice protection, a more aggressive test approach consisting of endurance runs might be used.

In 1975, the HISS was modified to correct some of the problems that were discovered during the previous testing. The primary changes were:

1. Dual spray booms in the center section designed to increase cloud depth.
2. The upper spray boom was lowered 4 feet below that of the original configuration to reduce the turbulence and downwash in the cloud caused by the CH-47 rotor wash.
3. Outer boom sections were canted downward to counteract roll-up tendencies of the spray cloud.
4. Nozzle locations were arranged to yield more uniform LWC distribution.

There were also several mechanical and electrical changes to improve operation. The same number and type of nozzles were used so that the water droplet size still was a problem.

Following modification of the HISS, another effort was made to precisely measure the microphysical properties of the spray cloud, this time using a laser nephelometer (cloud particle spectrometer). The measurement of cloud properties of the original HISS configuration used droplet impressions on gelatin coated slides. The nephelometer, mounted on a light twin-engine aircraft, measured the scattering of the laser beam by water droplets in order to count and size those droplets. The instrument was set to count and size droplets with diameters from 11 to 298 microns and to count but not size all drops above 298 microns. The previous measurement indicated that this size range would include all droplets generated by the HISS.

The measurement program proposed to relate LWC to water flow rate, airspeed, distance behind the spray booms, and vertical and horizontal position in the spray cloud. In addition, it planned to obtain drop size distributions and number densities and correlate these to the same parameters. The measurement program results indicated a representative drop size distribution which seemed relatively independent of any of the other parameters. The data indicated a very broad spectrum of drop sizes (from 10 to 200 microns with occasional drops greater than 300 microns).

The droplet concentration in the HISS cloud was determined to be very low compared to natural clouds (1/2 to 4 drops per cm^3 for the HISS versus 20 to 100 drops per cm^3 for the natural clouds). This low concentration caused statistical problems in the LWC measurements. The LWC measurements showed extreme variability not only from one test condition to another but also between successive measurements of the same test condition. This variability was primarily caused by the low probability of sampling a large drop and the large effect on LWC of sampling one large drop. The contribution to the liquid water measurement of a drop is dependent on the third power of the drop diameter. Therefore, one 250 to 300 micron drop can alter the LWC measurement for a given condition. Samples were encountered which differed by 0.5 gm/m^3 only because of the occurrence of one large drop in one sample. The nonuniformity of the cloud also contributed to the problems in getting a representative LWC measurement for each condition. Because we lacked an accurate measurement of LWC, the relationship between water flow rate, LWC, and airspeed was calculated from an estimated cloud cross-section and measured airspeed, assuming conservation of mass while correcting for evaporation.

The current HISS configuration includes an 1800-gallon water tank mounted internally in the CH-47C, with large tubular booms operated by hydraulic actuators such that they may be raised and lowered beneath the aircraft. The top horizontal spray boom is located approximately 20 feet below the aircraft. Total width of the spray booms including outriggers is 60 feet. The booms and part of the supporting structure are jettisonable in an emergency. The water can also be jettisoned. Radar altimeter antennas are mounted in the aft section of the CH-47 such that the crew of the CH-47 can position the test aircraft at the precise standoff distance selected for the icing encounter. A sensitive outside air temperature gauge and an instrument for observing relative humidity are located in the CH-47. Because of gross weight and center of gravity limitations, the aft fuel cells of the helicopter are left empty and only 1500 gallons of water are carried. This limits flight time on the CH-47 to approximately an hour and forty-five minutes. Typical spray times for the HISS with some assumed conditions are shown in figure 1, and are representative of normal operation. The assumptions in figure 1 include 25 percent relative humidity at 200 feet standoff distance, 90 knots true airspeed, -5 degrees Celsius and considers 100 gallons of water used to stabilize the cloud prior to actual test. The cloud generated by the HISS is approximately 12 feet deep in the center and near 60 feet in width. The spray cloud is created by pumping water from the tank to the nozzles in the booms and atomizing the water with engine compressor bleed air. The LWC of the cloud is controlled by adjusting the water flow rate and the air pressure. There are 174 nozzle locations on the booms. Atomizers are only used at 54 of the locations at one time because of a limited air supply. It is felt that the 15 psi bleed air pressure used in atomization of the water is insufficient for the nozzle orifice size and flow, which results in the large water droplet size and small droplet distribution.

The current capabilities and limitations of the HISS include: airspeeds from 60 to 155 knots indicated airspeed and altitudes up to 12,000 feet density altitude. Liquid water content range is from approximately 0.15 gm/m^3 to 1.0 gm/m^3 with droplet sizes ranging from 10 microns to in excess of 300 microns.

FIGURE 1. TYPICAL SPRAY TIMES

| | | LWC (G/M ³) | | | |
|------------------|--|-------------------------|-----|------|-----|
| | | 0.25 | 0.5 | 0.75 | 1.0 |
| FLOW RATE (GPM) | | 18 | 30 | 54 | 72 |
| SPRAY TIME (MIN) | | 78 | 39 | 26 | 19 |

In October and November of 1976, the HISS was again called upon for icing work. At this time two competitors for the Army's utility tactical transport aircraft system (UTTAS) were the targets. The Sikorsky YUH-60A and the Boeing Vertol YUH-61A were contenders in the competition for the Army's replacement utility helicopter. The requirements to conduct the icing tests during October and November dictated the use of Fort Wainwright, Alaska. The HISS was ferried to Fort Wainwright in September and prepared for arrival of the test aircraft in early October. The booms were removed and stowed inside the HISS in special racks to expedite the ferry trip. The purpose of the UTTAS icing tests was to determine the potential of the electrothermal ice protection system of each aircraft. Boeing Vertol's system in the YUH-61A was in a prototype development stage and very close to a production configuration, while the Sikorsky YUH-60A ice protection kit was in the preprototype stage, and required an on-board engineer to operate the system. Fort Wainwright, which is near Fairbanks, Alaska, was an excellent test site in that the inversion conditions that existed there at this time of year allowed the aircraft to bring back almost all of the ice that was collected during each flight. Maximum exposure times and conditions that were flown are shown in figures 2 and 3 for the Sikorsky and Boeing Vertol aircraft, respectively. The photo shows the Boeing aircraft following a 45-minute encounter at conditions of 10°C and 0.5 gm/m³ LWC. The ice formations beneath the forward portion of the aircraft indicate rather large droplet sizes, which is a problem with the HISS in simulating the natural environment.

The yellow color of the ice is a result of dye being placed in the water to improve photo documentation. Conclusions from this test indicated that both systems had adequate potential for their deice protection kits to be developed into workable systems. The early identification of problems with each system allows the contractors opportunity for timely correction. Again, the HISS was successful in allowing us to gather a significant amount of icing data in a very short period of time, in fact, less than five weeks. Although probably not completely representative of the natural environment, enough data had been gathered to significantly evaluate each aircraft's ice protection system and delineate those areas which required improvement.

FIGURE 2. YUH-60A MAXIMUM EXPOSURES

LWC (G/M³)

| | | MINUTES | | |
|--------------|-----|---------|------|------|
| | | 0.25 | 0.50 | 0.75 |
| TEMP (°C) | -5 | 21 | | |
| | -10 | 53 | 34 | |
| | -15 | 42 | | |

FIGURE 3. YUH-61A MAXIMUM EXPOSURES

LWC (G/M³)

| | | MINUTES | | |
|--------------|-----|---------|------|------|
| | | 0.25 | 0.50 | 0.75 |
| TEMP (°C) | -5 | | 22 | 13 |
| | -10 | 39 | 29 | |
| | -15 | 48 | | |

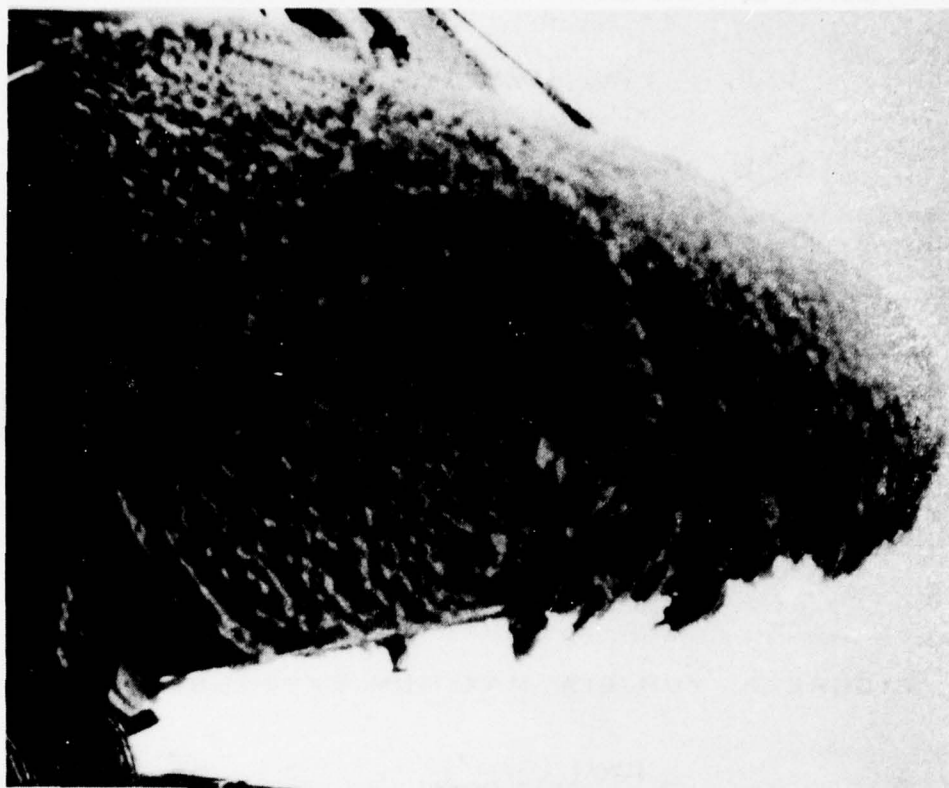

Beginning in January of this coming year the HISS will be called upon again to evaluate the ice protection capabilities of several aircraft. A program is planned beginning in January of 1979 to qualify the UH-60A Blackhawk ice protection system utilizing the HISS. Another ice protection system installed in a CH-47C with fiberglass rotor blades will be evaluated. Both of these systems are of the electrothermal type utilizing blankets in the leading edge of each rotor blade. A third program which is more research oriented will be done with the Federal Aviation Administration's support to evaluate procedures and techniques required to certify civil aircraft as well as military aircraft for operation in the icing environment. This effort will include testing with heated and unheated blades and in conjunction with the test, a kit for the UH-1H will be qualified. This kit includes a heated windshield, an icing severity indicator, and an improved outside air temperature indicator. These programs are scheduled to be conducted near Minneapolis, Minnesota, to be followed by a natural icing phase in Syracuse, New York, for the UH-60A and UH-1H. Natural icing is not planned this session for the CH-47C with the fiberglass rotor blades.

The qualification of the UH-60A for flight in the icing environment will be done behind the HISS with validation in the natural environment. Figure 4 shows test conditions that are planned behind the HISS. A duplication in the natural

environment for as many points as possible will allow us a determination of correlation between the HISS and the natural environment. At this point in time, it is generally agreed that even though our HISS is not precisely representative of the natural environment, it is more harsh, and that aircraft that endure the HISS icing can with high probability also survive those conditions in the natural environment.

FIGURE 4. UH-60A TEST CONDITIONS

| | | LWC (G/M ³) | | | |
|--------------|-----|-------------------------|------|------|-----|
| | | 0.25 | 0.50 | 0.75 | 1.0 |
| TEMP (°C) | -5 | X | X | X | X |
| | -10 | X | X | X | |
| | -15 | X | X | | |
| | -20 | X | | | |

As time and funds permit during the next year, the Army Aviation Engineering Flight Activity will continue to improve the HISS to make its approximation of the icing environment more representative of the natural environment. This effort is primarily directed at reducing droplet size and increasing droplet distribution. Whether or not this can be accomplished without unacceptable trade-offs is not presently known.

APPLICATION OF THE SPANWISE SHEDDING
ROTOR BLADE DEICING CONCEPT

by

Phyllis F. Kitchens
Aerospace Engineer
Applied Technology Laboratory
US Army Research and Technology Laboratories
(AVRADCOM)

Presented to the
Helicopter Icing Symposium
sponsored by
NATO Panel X
at the Royal Aeronautical Society
London, England

6,7 November 1978

APPLICATION OF THE SPANWISE SHEDDING ROTOR BLADE DEICING CONCEPT

INTRODUCTION

Background

Since 1972 the Applied Technology Laboratory (ATL), US Army Research and Technology Laboratories (AVRADCOM), has been conducting a helicopter ice protection research and development program. The objectives of this program are to provide design and test criteria for helicopter ice protection for incorporation into future Army helicopters, and to insure that the technology is available to meet these criteria. A secondary objective is to provide ice protection technology for application to existing helicopters. Details of the ATL program are contained in Mr. Adams' paper (Reference 1).

One of the major technological voids identified in the ATL program was that of rotor blade ice protection. This paper describes the process by which the spanwise-shedding electrothermal concept was selected for design, fabrication, and testing to verify the accuracy of the ice protection design criteria and to demonstrate the feasibility of a rotor blade ice protection system. Reference 1 describes other rotor blade ice protection techniques we have investigated in search of lighter-weight, lower-cost systems.

Design Criteria

Based on a detailed study of worldwide meteorological data, Werner (Reference 2) developed a recommended helicopter design criteria for supercooled clouds. These criteria, which represent a 99th percentile exceedance probability, are shown in Figure 1; they are similar to FAR 25 with a few exceptions. Because of the low altitude levels generally associated with Army helicopter operations, the minimum temperature extreme is recommended to be -20°C (-4°F), rather than -30°C (-22°F), and the highest liquid water content for intermittent maximum icing is 2 g/m^3 rather than 2.9 g/m^3 .

Because snow and freezing rain are other meteorological conditions typical of the winter season, these data were also studied. Figure 2 shows the ATL recommended design criteria for snow. In actuality, a rotor blade ice protection system designed to operate in the supercooled cloud environment should be capable of satisfactory operation in snow. Figure 3 depicts the design criteria recommended for freezing rain. Because of the large diameter droplets ($40\text{ }\mu\text{m}$ and larger), the impingement area calculated for freezing rain covers most, or all, of the rotor blade chord; in addition, other currently unprotected areas of the fuselage would require ice protection. To satisfy the design criteria for severe freezing rain would require an unreasonably large amount of power, with the attendant high weight, for a helicopter application. For these reasons, freezing rain protection was not required in the design of our rotor blade ice protection system.

However, due to the prevalence of freezing rain conditions and the implications on operational availability, we have begun an exploration of this environment in flight test to determine if there exists a temperature and severity envelope in which helicopter operations can be conducted. Our latest icing test experience with the ice-protected UH-1H is discussed in References 3 and 4.

Rotor Blade Ice Protection Concepts

Under a contract with Lockheed-California Company, the following major blade ice protection concepts were evaluated: electrothermal, bleed air, heated liquid, chemical freezing point depressant, mechanical pneumatic, electro-impulse, sonic pulse and ice phobic coatings. Of these, three ice protection concepts were considered promising enough for application to the UH-1H to be investigated in detail: chemical freezing point depressant, electrothermal and heated liquid. Figures 4 through 6 show possible applications of each concept. Based on trade-off analyses, which considered effectiveness, weight and performance penalties, reliability, maintainability, vulnerability, and cost, the electrothermal deicing concept was selected for development and engineering flight test.

Spanwise Versus Chordwise Shedding

An early study by Stallabrass and Gibbard (Reference 5) demonstrated essentially equal performance of spanwise and chordwise shedding concepts and showed that spanwise shedding required approximately 60% less energy at the lower temperatures. This advantage is off-set by the chordwise shedding concept's lower weight and manufacturing simplicity, resulting in a lower unit cost as well as better reliability and maintainability characteristics. Lazelle (Reference 6) stated a belief that spanwise heater strips are less prone to runback than chordwise elements, offering another potential advantage to chordwise shedding.

One of the most favorable aspects of the spanwise shedding concept, as described in Reference 4, was its postulated "inherent redundancy," i.e., if one heater zone failed, the others would continue to shed; the effect on performance is expected to be small enough that flight could be continued with the remainder of the zones operating. Although some measure of "inherent redundancy" may be realized with the chordwise shedding concept, depending on where the failure occurred, failure of a critical zone (e.g., leading edge) may adversely affect blade stability. The ice protection system on the ATL test bed helicopter was designed using the spanwise shedding concept, based on the expected advantages. To prevent large-scale rotor blade imbalance, the ice protection system controller automatically shuts off power to the opposite blade in the heater zone corresponding to the failed one. Figure 7 shows typical arrangement of the spanwise and chordwise shedding concepts.

System Design

Briefly, the ice protection system design is depicted in Figure 8 and described in detail in Reference 4. Three-phase AC power for the electro-thermal devices is provided by a 20/30 kVA generator, which replaces one of the two standard DC generators. A transformer/rectifier has been added to provide standby DC power. In addition to the deiced main and tail rotor blades, the stabilizer bar, tip weights and windshields are anti-iced. The windshields are of glass laminate construction with a transparent tin oxide heater element. Power for main rotor blade deicing and instrumentation is routed through a standpipe in the rotor mast to slip rings mounted on top of the hub; a hybrid stepper switch is also located in the main rotor slip ring cannister. For R&D purposes, the ice protection system was designed to work at three voltages: 160, 200, and 230 Vac; total power consumption is 16.3, 25.4, and 33.6 kW, respectively, corresponding to these voltages. Table 1 lists the weight of the components of the prototype (1973) ice protection system, along with a 1974 estimate of production system weight. Because of advances in hardware and changes to the UH-1, such as the incorporation of glass windshields, reduction in the weight directly associated with ice protection can be achieved; these projections are also shown in Table 1 for comparison purposes. The rationale for the reduced ice protection system weight is contained in References 7 (for the 1974 estimate) and 1 (for the 1978 estimate).

ORIGINAL HEATER BLANKET

General Design

Based on calculation of the impingement area, using a $40\ \mu\text{m}$ droplet diameter, it was determined that the heater blanket coverage required for the UH-1H's NACA 0012 main rotor blade would be 10% chord on the upper surface and 25% on the lower surface. (In manufacture, the actual heater coverage achieved was 12% upper and 29% lower surface.) Spanwise, the heater element runs from station 24.5 (8.5%R) to station 287 (99.6%R). The primary reasons why full-span main rotor blade ice protection was selected were to insure maintenance of autorotative capability and to reduce the danger of strikes by large pieces of self-shed ice from the inboard area. A secondary consideration was to minimize any performance degradation in flight due to inboard ice retention. The tail rotor heater covers 10% chord on the outboard surface and 25% on the inboard surface, with the heated area running from station 20.68 (40.5%R) to station 50 (98%R). The remainder of the discussion in this paper concerns only main rotor ice protection.

This ice protection system was designed to operate at three voltage levels for experimental purposes. The main rotor blades are divided into six spanwise heater zones, as shown in Figure 5. To take advantage of kinetic heating, power density is varied with span, as shown in Figure 9, for 200 volt operation. At 200 Vac, power consumption by the main rotor blade deicer is 6.7 kW per zone per blade. In a deicing cycle, the heaters are activated from tip to root.

Detailed Design, Material Selection, and Fabrication Techniques

Because of limited time and budget, the overall approach in the design of the heater blanket was to first determine the desired characteristics of each component, then examine laboratory test data of many materials and the operational experience records of various heater boot installations. Based on the results of this study, candidate materials were selected; work was then concentrated on optimization of the fabrication techniques and testing of the selected design.

The basic qualities which the erosion shield material must possess are shown in Table 2; to satisfy these requirements, a metallic erosion shield was used. Soft electroformed nickel ($E = 20 \times 10^6$ psi) was selected as the optimum erosion shield material for application to either all-aluminum or composite rotor blade heater blankets. Because electroformed nickel can be tapered economically, the maximum material thickness can be placed at the leading edge for erosion resistance, then the thickness reduced to approximately 0.005 to 0.010 inch at the trailing edge. This ability offers reduced weight and better control of balance, and allows aerodynamic fairing of the shield into the blade. The superior heat transfer capability of nickel, compared to steel, also conserves electrical power. Since electroformed nickel can be formed into complex shapes, the UH-1H erosion shield could be fabricated in one continuous length from the doubler area to the blade tip.

However, because only three blades were modified for this program, some compromises in design were necessary to reduce cost and to meet the schedule. To accommodate the cross-section changes in the doubler area (the inboard 30% of the blade span), a two-section erosion shield was designed. The inboard end of the shield is 0.016-inch-thick 7075T6 aluminum, and the outboard end is 0.030-inch-thick 1/4H 301 stainless steel.

The desired qualities for the rotor blade heater element and five types of heater elements commonly used in airfoil deicers are listed in Table 2. Etched stainless steel foil was selected for the development program.

The remaining components of the heater blanket include the dielectric material and adhesives. Selection criteria for the dielectric material and the three candidate configurations evaluated are listed in Table 2. The results of the initial screening indicated that all three possessed acceptable dielectric strength (greater than 10 megohms) and equivalent heating efficiency; however, the third configuration (2 plies of 106 style glass fabric impregnated with epoxy resin) was selected based on its significantly greater bond strength.

Two methods of attaching the heater blanket to the blade were examined. The desired characteristics of the attachment are good load transfer capability, ductility, stability over the temperature range from -67°F (-55°C) to 200°F (93°C), and good weather and fluid resistance. A "hardback" attachment, consisting of a layer of glass fabric epoxy laminate and nylon

fabric reinforced epoxy adhesive, was selected over a "softback" attachment, which was composed of a layer of rubber with epoxy adhesive.

The review of deicer experience data revealed that many of the problems encountered in service were due to faulty fabrication procedures and processing. For these reasons, emphasis was given to incorporating the latest procedures and controls for adhesive bonding. Table 3 lists the general procedures used that were essential to insure successful, void-free bonding.

Three heater blanket configurations (numbered 1 through 3 in Table 4) were tested to determine dielectric strength, thermal conduction characteristics and interlaminar bond strength. Dogbone samples were cycled in tension to evaluate load transfer and fatigue characteristics under centrifugal force loading. Fatigue tests were also performed to evaluate behavior caused by combined centrifugal force and dynamic moments (chordwise and beamwise bending). Electrical continuity and bonding integrity were continuously monitored throughout the tests.

Table 5 shows the final deicer boot selection; Reference 9 gives details of the fabrication methods, processes, and manufacturing sequence. Figure 10 shows a cross section of the original heater blanket layup, along with a sketch of the heater element.

Testing to determine flatwise tensile strength and shear strength was also performed on coupons cut from a sample production blade and from the ends of each of the three production heater blankets. The results of the tests showed that shear strength is the lowest at the upper surface trailing edge of the deicer boot, where copper braided wire conductors are located. The tests also verified that the strength of the nonbraided area was sufficient to carry all loads. Fatigue tests were also performed on a sample production blade; a total life of 6,000 hours (40,000 stop/start cycles) was recorded without bond delamination.

Reference 9 also details the methods of nondestructive testing used to verify integrity of the bond in the finished deicer assembly. The C-scan, through-transmission method, was used to map voids, including implanted Teflon disks as small as 1 inch in diameter. Figure 11 shows a typical C-scan map. A second C-scan was made following the airworthiness flight tests, which showed no change in the recordings after 34.4 operating hours (15.3 flight hours). Hand tapping was also shown to be effective in detecting voids if there was a substantial air gap. Tap-testing has been used throughout the test program, following each day's operation, to monitor the growth of voids and to detect new ones.

Deicing Control

The rotor blade deicing control system has become more sophisticated as experience in flight test has been gained. The original design of the deicing controller programmed main rotor heater on-time as a function of outside air temperature (OAT), as shown in Figure 12, and heater off-time

as a function of icing severity level (Figure 13). The AC generator voltage was controlled to provide 160 volts for light icing, 200 volts for moderate icing, and 230 volts for heavy icing. To minimize generator cycling, a muting circuit was incorporated, which held the voltage constant for a 5-minute period.

As flight testing has progressed, the on- and off-time schedules have been tuned to optimize system performance. Due to the lack of a satisfactory in-flight photographic capability, we have been relying primarily on visual inspection of rotor blade deicing performance observed in the Ottawa spray rig to verify control parameters. The proper operation of the blade deicing system under natural icing conditions has been inferred from qualitative evaluation of the test helicopter's performance. Partly because of this instrumentation deficiency, we have developed a very conservative flight test envelope expansion procedure (detailed in Reference 3) to insure flight safety.

Deicing System Saturation

It is conceivable that, without careful design, a rotor blade deicing system might encounter an icing severity condition in which the heater off-time is greater than the time in which a "critical" thickness of ice is accumulated. This condition has been described as system saturation (Reference 4). In chordwise deicing applications, this problem has been compensated for by applying power to heaters in the critical area (e.g., leading edge) more than once during a deicing cycle. Figure 14 shows the analysis of system saturation performed for the ATL ice protection system. As can be seen, saturation of this system is not likely to occur in the icing severities experienced in nature.

Testing Experience with Original Heater Blanket Design

Reference 9 describes the airworthiness testing (ground tie-down and clear air flight tests for verification of structural integrity) and clear air functional flight tests performed prior to the first icing tests. Reference 9 also details the simulated icing tests performed using the Helicopter Icing Spray System (HISS), a CH-47 tanker. This paper presents the results and conclusions relating directly to the main rotor blade deicer and control system; References 3, 9, 10, and 11 are the detailed test reports.

Simulated icing conditions tested with the HISS in 1975 are shown in Figure 15; also plotted is a curve of the FAR 25 criteria for continuous maximum icing conditions. Although no pictures were obtained with the hub-mounted camera (due to failure of its window heater), satisfactory performance of the ice protection system was verified by visual and photographic observation from the chase helicopter. This observation of ice shedding led to the conclusion that heater on-time could be reduced 2 seconds per zone. Deicing was observed to occur in the intended zone-by-zone sequence. Usually the sheds were so symmetrical that the flight crew was unaware of when they occurred. On a very few occasions, the crew could detect sheds by a barely perceptible, low level, one-per-rev vibration.

With the exception of the inboard area, shedding was generally complete. At temperatures of -10°C (14°F) and below, some ice was retained on the inboard zones (the aluminum erosion shield). Increasing blade surface temperature to as much as 12°C (54°F) failed to produce clean shedding at the root area. Two factors were thought to be responsible for this problem: the 1-inch-wide unheated joint between the steel and aluminum erosion shields (caused by the production break at blade station 83) and the thick bridge of ice that formed over the unheated blade grip clevis at the root end. The latter formation is typical of the HISS, because of the large droplet diameter. Also because of the large droplet diameter, there were a few discrete, drop-like deposits of ice in the root area on the lower blade surface extending to the trailing edge. Although direct inspection of the rotor blades in flight was not possible, there was no indication that significant runback was occurring.

The major problems experienced with these main rotor blades were electrical: one open wire and four shorts-to-ground occurred in the heater power supply line. Figure 16 shows a typical open circuit. All the electrical problems were repaired in the field using "open blade surgery" to cut away the erosion shield and to expose the shorted or open element. After splicing and insulating, the shield was patched with sealing compound, leaving a small cold spot. Dielectric strength between the heater blanket and the erosion shield varied considerably during the flight test; it was suspected that moisture ingress under the erosion shield was responsible for the loss of strength and that the degradation would correlate with an increased incidence of shorts. During the summer period between flight tests, the blades were stored in a desert environment; at the end of the storage period, dielectric strength had returned to its original high level. Other problems which occurred during the HISS tests, including failure of the main rotor standpipe, which carries power and instrumentation wiring through the mast, are described in Reference 9.

In 1976 flight tests were performed in the Ottawa spray rig to optimize deicing control parameters and to evaluate ice protection system effectiveness. Because it was apparent that excessive runback was occurring with the heater on-times which had been used in the HISS tests, heater on-time was progressively reduced. A theoretical optimum on-time was determined and is shown, along with the original on-time versus OAT schedule, in Figure 17. (With the ATL deicing control system, on-time can be reduced either by changing potentiometer adjustments for each zone or, as was done here, by biasing the OAT signal a number of degrees colder.)

The off-time schedule used in the spray rig was essentially the same as that used during the HISS tests; it is represented in Figure 13 by the curve $\text{LWC} \times \text{off-time} = 1.75$, with off-time expressed in minutes. There is some scatter in the actual data points because in testing, allowances must be made for wind velocity, gustiness, and the amount of rotor immersion in order to accrete a constant $1/4$ inch of ice at the main rotor blade mid-span.

Preparations for natural icing tests were made in 1976, although the desired weather conditions did not materialize. It was realized that proper deicing

control, which will result in deicing at a constant thickness of rotor blade ice accretion, could not be accomplished with the 5-minute muting circuit in our controller. Because off-time needs to change as LWC changes, it was decided that some way of integrating LWC with respect to time was needed. A testing technique was devised and checked out satisfactorily in the spray rig which scheduled manually-initiated rotor blade deicing cycles to coincide with a specific number of ice detector probe deice cycles ("counts"). Later, a system (the Integrating Rate Unit) was devised which performed a rigorous LWC integration and scheduled rotor blade deicing either manually or automatically. Reference 11 gives a detailed discussion of both the Integrating Rate Unit and the "count" system, along with the limitations of the latter.

The ice protection system operated effectively with only two rotor blade deficiencies: mild runback on the inboard 20 to 40% span and residual leading edge ice at the joint between the steel and aluminum erosion shields (station 83). It was thought that the amount of runback was insufficient to degrade autorotative performance, but this was not verified by flight test. The station 83 problem was suspected to be due to the physical discontinuity caused by the change in material thickness between the 0.016-inch aluminum and the 0.030-inch thick steel, as well as to a 1-inch-wide cold band at the production joint, resulting from inadequate heater coverage.

Three shorts to ground occurred in the main rotor blades; all three were located in the leading-edge area and were apparently due to a breakdown of the insulation between the heater element and the erosion shield. There was also a reduction in dielectric strength of this insulation as testing progressed, which was thought to be due to moisture ingress either under the erosion shield or into the root end electrical connector.

HEATER BLANKET REDESIGN

Results of Teardown Inspection

The main rotor blade heater boot which had experienced two shorts to ground in the outer span was disassembled for inspection. Figure 18 shows the etched foil heater element after the steel erosion shield was removed. Table 6 shows the discrepancies noted during the teardown inspection.

Analysis of the leading edge failures concluded that the problem was due to a manufacturing defect caused by poorly-fitted tooling, which resulted in voids in the leading-edge area. The incomplete bonding contract and adhesion along the leading edge might have caused hot spots which eventually broke down the insulation, allowing arcing between the heater element and the erosion shield. The dry-appearing condition of the inboard insulation material suggested that the insulation might act as a wick conducting moisture into the heater boot if the outside edges were not completely sealed.

New Deicer Boot Design

The outboard deicer boot on each of the three main rotor blades was replaced with one of an improved design. The major changes in design involved: increasing the insulation thickness between the heater element and the erosion shield, as well as between the wire braids at the trailing edge and the shield; improving the fit of all mating parts, especially in the leading edge area; reducing both the unheated area and the amount of erosion shield cross-section change at station 83; and improving the sealing along the trailing edge of the boot. The tooling used was also improved to provide a better leading edge fit. The major procedural change was improving quality control to insure better bonding. Primarily as a result of the increase in insulation thickness, heater on-time later had to be increased approximately one-half second to achieve the desired blade surface temperatures. Figure 19 shows the final outboard deicer boot layup.

FLIGHT TEST EXPERIENCE WITH REDESIGNED HEATER BLANKET

General

Flight test experience with the redesigned deicer boots in both the Ottawa spray rig and natural icing during 1977 and 1978 is summarized here. In the two years, the redesigned heater blankets have operated a total of 43.5 hours without recurrence of electrical shorts to ground. This compares with the original design, which experienced shorts at 25.6 and 37.9 hours on one blade and 43.4 hours on the other. The dielectric strength of the insulation material was still observed to fluctuate during testing; however, it is now suspected that some part of this change is due to inconsistencies in reading the instrument, a 500-volt megohmmeter.

Changes to the rotor blades prior to the 1977 tests were described above; before the 1978 tests, a few additional changes were also made. The five 0.003-inch-high steps made to taper the inboard end of the steel erosion shield down to the thickness of the aluminum shield were smoothed on the uninstrumented blade to further reduce the tendency for ice to hang up. Some outboard spanwise temperature sensors, which had been damaged or washed off previously, were replaced and moved further aft of the leading edge to extend their life. Six additional temperature sensors were added around the main rotor chord at 38% span (station 110, in zone 4). This position was selected after a review of the spray rig photographs, which indicated that this station had the maximum chordwise ice coverage. The most inboard temperature sensor (zone 6) was moved slightly outboard (from station 46 to 55) in attempt to achieve a more representative temperature.

Spanwise Surface Temperature Distribution and On-Time

Figure 20 shows the measured blade surface temperatures for three conditions. The -2.3°C (27.9°F) graph shows the repeatability of the temperature data between two successive runs in the spray rig. On the inboard area, the effect of sublimation is indicated by the lower temperatures recorded out

of the cloud compared with the higher temperatures in the cloud. This also confirms that the critical case for deicing (i.e., the lowest blade surface temperatures and longest on-time required) occurs when the helicopter emerges from the cloud into clear air. Also shown in this figure is the cooling effect of the supercooled water droplets on the outer portion of the blade, where kinetic heating results in above-zero surface temperatures. The extent of kinetic heating has been reduced substantially by evaporation. Note that the spanwise intersection of the in-cloud and out-of-cloud curves corresponds to the end of the ice coverage that was observed on shutdown; this point also corresponds to the 0°C crossover point for the two curves. The trends for tests at -6.5°C (20.3°F) and -18°C (-0.4°F) are similar although not as obvious.

Figure 21 represents all the data collected up to and during 1977 and compares this with various adiabatic recovery factors. As can be seen in the lower curve, the bare blade exhibits about 85% adiabatic recovery except in the inboard 50% span, where a higher temperature has been recorded. It has been postulated (Reference 11) that this temperature rise reflects the effect of blade twist.

Figure 22 shows the average slope of blade surface temperature rise, during the first four seconds of heater operation, versus blade station, along with the spanwise power density distribution. As can be seen, the heating rate in the inboard zones is considerably higher than that of the outboard zones, and does not follow the smooth power density change. Part of this high temperature is due to the combination of steel and aluminum erosion shields, which cover the zone 5 heater. On-time in zone 5 must be sufficient to deice the steel on the outboard half, obviously resulting in runback from the inner, aluminum half, which is overheated. Other data indicate that the zone 6 power density is actually 33 watts/in² rather than the intended 26 w/in² value.

The above analysis indicates that on-time should ideally vary from the outboard to the inboard end of each zone. Figure 23 shows the on-time that would be required to raise the blade surface to 0°C. This figure indicates the effects of different amounts of adiabatic recovery as well as variable outside air temperature. With our deicing controller, it is currently possible to program only a constant on-time per zone. The on-time must be long enough to deice the inboard end of a zone (where the kinetic heating is less), which results in a longer-than-optimum on-time for the outboard part of the zone. An alternative to the spanwise variation of on-time, as described above, is to vary power density continuously from tip to root, as opposed to the step-like changes in each zone of the ATL blades.

As shown in Figure 23, it is important for the designer to be able to define the actual adiabatic recovery factor for the outboard zones. The atmospheric moisture also affects blade temperature, but our limited amount of data indicates that, in general, the effect of LWC may be of lesser importance to design than other trade-off factors such as controller simplicity. One caution must be made here: the effect of mixed conditions on adiabatic recovery is not well-defined at present. This condition may

increase the importance of LWC to the designer. Investigators of the Canadian National Research Council (Stallabrass et al) and in the United Kingdom have been examining the effects of mixed conditions in the icing tunnel and may be able to shed further flight on this subject.

Figure 24 shows the blade surface temperature at the beginning of a deice cycle and the maximum temperature reached during the cycle. This figure shows temperature on the outboard zones to be above 0°C (32°F) due to kinetic heating (no ice on the blade). It also shows the high surface temperature needed to deice zone 6, which causes the runback frequently observed here. The marginal heating of the stainless steel half of zone 5 is clearly displayed, indicating the need for a longer on-time or greater power density here. Blade surface temperature passes through 0°C in a tip-to-root sequence; hub camera film from spray rig tests frequently showed ice sheds occurring in half-zone increments: the outboard half shedding first, followed closely by the inboard half.

Based on a 50% kinetic heating factor, the on-time required to raise the inboard end of each zone to 0°C is plotted versus OAT in the upper part of Figure 25. Note that the slope and zero-intercept are different for each zone due to the temperature and kinetic heating variations. A "possible" on-time versus OAT schedule is also shown in Figure 25. However, when this schedule is compared with successful deicing runs in the spray rig, it is necessary to increase the on-time by one second to insure acceptable inboard deicing. This "recommended" schedule is shown in the lower part of Figure 25. Reflecting the electrical economy of the spanwise shedding concept, it is believed that the on-times used with this deicer are significantly shorter than those of chordwise systems. Due to the lack of published data, however, the accuracy of this belief cannot be substantiated at this time.

Chordwise Temperature Distribution and Ice Coverage

Temperature sensors at station 110 (38% span) were located on the blade upper surface at 5- and 10-percent chord, and on the lower surface at 4-, 9-, 14-, and 25-percent chord. Figure 26 shows temperature measured during natural icing flights at -9°C and -11°C . These data represent a transient case with a fairly uniform temperature rise around the chord. Because of the thermal capacity of this heater blanket, which allows the use of short energy on-times, there is no need to vary power density around the blade chord. In a different heater blanket design, using a lower power density and long on-times, a chordwise power density variation may be necessary. A detailed thermodynamic analysis of any heater blanket design is necessary to determine if chordwise power density variation is required.

A typical sketch of the chordwise extent of ice coverage on the lower blade surface, as observed in the spray rig, is shown in Figure 27. The maximum extent of ice, which occurs in the 35% span area, is approximately 29% chord. The majority of the densely packed ice lies within 20% chord, with pebbly ice formations making up the remainder. The ice coverage tapers to about 6% to 7% chord at the blade tip. On the upper surface, the ice

formation is fairly uniform, extending up to about 3 1/2% chord (1/2 to 3/4 inch behind the leading edge.) As previously stated, the heater blanket coverage for the test blades is a constant 12% chord on the upper surface and 29% on the lower. It must be emphasized that the measured ice accretion pattern is a function of blade angle of attack for hover; any reduction in heater coverage must provide adequate protection for the full flight profile.

Residual Inboard Ice

An experiment was performed to assess the effect of inboard ice retention on flight safety prior to the initiation of natural icing tests. Using the spray rig, three deicing cycles were executed with only the four outboard zones being heated. Inspection revealed that ice covered the inboard 25% span and was a maximum of 1/8-inch thick. An autorotation was executed in which there was a 22 RPM decrease compared to normal rotor speed for this gross weight with clean blades. Although weather conditions during the remainder of the 1977 and all of the 1978 test seasons prevented repetition of this test to verify the results, there are some implications to the deicing system designer. If inboard deicing is accomplished less often than outboard, to obtain a greater ice mass and promote cleaner shedding, the ice protection system must be capable of shedding that inboard ice prior to entering emergency autorotation.

Off-Time

In the ATL program, flight testing began using a heater off-time based on 1/4-inch ice accretion at the main rotor blade midspan. This number was an empirically established limit for the UH-1H; previous testing had indicated that ice accretion thickness on the order of 1/4-inch did not result in asymmetric self-sheds. Also, shedding ice of this thickness did not cause damage when striking other helicopter components. Other ice accretion thicknesses, from 1/8 to 3/8 inch, have been tested.

To achieve clean shedding in the spray rig, it was discovered that there is a need to accrete a thicker layer of ice on the inboard section of the blade than the 1/4-inch midspan guideline would allow. The need for more ice mass and longer off-time in the inboard area is believed to be largely due to the lower centrifugal force, which reduces the tendency to shed. Ideally, it appears that the deicing controller could be designed to heat the inboard zones every other deicing cycle. Since the ATL controller is not capable of performing the ideal sequence in the automatic mode, a single longer off-time, deicing with approximately 3/8-inch ice at midspan, was used for some spray rig and natural icing tests. No detrimental effects were noted during the tests in forward flight due to the increased ice thickness; however, there were some dents in the tail rotor drive shaft cover caused by ice shed during hover.

The trade-offs which must be taken into consideration by an ice protection system designer are exemplified by question of ice accretion thickness. As described above, cleaner inboard deicing occurs with increased ice thickness.

However, this increased thickness can also increase range penalty when operating in icing. A post-test analysis of torque increase between deicing cycles, which was experienced on two natural icing tests, showed an increase of approximately 2.5 psi when deicing at the 1/4-inch accretion thickness. This torque increase was used to calculate increased fuel flow and hence reduced range, which would result from the blade ice drag between cycles. The analysis, which assumed ideal clean shedding, indicated that range performance would be improved by deicing more frequently, at approximately 1/8-inch midspan accretion. The designer must weigh the variables: the need to preserve autorotative capability by maintaining a clean inboard area, and the need to minimize forward flight performance loss by deicing frequently.

Inherent Redundancy

During the first spray rig test in 1977 the deicing system controller operated out of synchronization. Instead of the normal heater operation from zone 1 (tip) to zone 6 (root), the heaters actually operated in the sequence 5, 6, 1, 2, 3, 4. For a single deicing cycle, the blades deiced cleanly; however, after a 15-minute immersion a considerable amount of ice remained on the leading edge of zones 4, 5, and 6. There was also a good deal of runback from zones 5 and 6; the repeated use of longer off-times and shorter on-times did not improve the multiple-cycle performance.

Analysis of test data showed the out-of-sequence heater operation as well as longer-than-normal on-times for zones 5 and 6 and shorter-than-normal on-time experienced in zone 4. The runback in zones 5 and 6 and the retained ice in zone 4 were directly attributable to the improper on-times.

The leading-edge ice retention in zones 5 and 6 casts some doubt on the validity of the "inherent redundancy" of the spanwise shedding concept, at least for the inboard zones where centrifugal force is low. As explained previously, one reason for selecting this concept was the hypothesis that if one zone failed, the other zones would continue to shed, allowing the flight to continue through the icing condition. The aerodynamic effects of the ice accreted by the single failed zone were assumed to be small enough (given controller deactivation of the same zone on the opposite blade for symmetry) to permit continued flight. In this test, it appears that the ice on zone 4, due to the short on-time, actually prevented the ice inboard of this zone from shedding. Whether this could happen if an outboard zone failed, given the higher centrifugal force, needs to be determined. More testing of simulated zone failures is needed to assess the validity of continuing to operate with one zone failed.

Vibrations Associated with Icing Flight

During almost all of our natural icing flights, there has been very little vibration which could be associated with rotor blade ice accretion or deicing. The only exceptions to this have occurred on two natural icing flights at high altitudes (9500 and 10,500 ft), during which a 6-per-rotor-revolution (6P) vibration occurred. Outside air temperature for these

tests was -5°C (23°F) and -6°C (21.2°F), respectively. The magnitude of the vibration was worse at the higher altitude; the amplitude was reduced when the heater cycled through zone 2, indicating that ice accreted out to 60% to 80% span was causing the problem. Although the vibration level was not excessive, it did increase pilot workload. Both the cg vertical accelerometer and the main rotor blade root flapwise bending measurement recorded the 6P vibration; the blade response data indicate that the third flapwise bending mode was probably being affected. It is assumed that the higher collective angles were responsible for this vibration occurring only on the high-altitude flights.

Tests in Snow and Freezing Rain

In 1976 tests performed in the spray rig, during a snowfall (mixed condition), resulted in engine inlet screen icing and blockage to the extent that testing had to be stopped until the screens were cleaned. Also during these tests, it was observed that the snow appeared to be contributing to the amount of inboard zone runback; however, it is now known that this problem is a trait of our prototype blades. During the 1978 tests a 30-minute hover was performed in heavy snow at -5°C (23°F); at the conclusion of the test, the rotor blades, fuselage and engine inlet screens were completely clean. The crew reported no performance or handling changes due to the snow. Based on these tests, it appears that the effect of operating in a mixed snow and supercooled cloud environment, on the UH-1H, is primarily inlet screen blockage; however, more data is needed to conclusively verify this.

Two tests in light freezing rain were made in 1978. The first was a 30-minute hover at -4°C (24.8°F), during which the blade deicing system was not activated. During engine shutdown, two separate main rotor blade sheds were noted. Some clear ice was found on fuselage protuberances and on the upper main rotor blade surface; the blade ice probably accreted during the period the blades were decelerating at shutdown, while the freezing rain continued to fall.

The second freezing rain test was performed at -2°C , under special VFR clearance at 100 to 300 ft AGL. For this test the ice protection system was cycled at an arbitrary 2-minute off-time using a 1.2-second on-time. The infrared ice detector occasionally indicated 0.05 to 0.3 g/m^3 . On shutdown the rotor blades were completely clean; no effects could be detected due to the freezing rain. The initial tests indicate that with windshield anti-icing to maintain visibility, there is a temperature and freezing rain severity envelope within which operations are feasible. Careful temperature and severity envelope expansion must be performed to establish the environmental limits, for operations with both ice-protected and unprotected helicopters.

SOME THOUGHTS ON THE COMPARISON OF SPANWISE
AND CHORDWISE SHEDDING APPLICATIONS

There have been some advances in materials and manufacturing technology since the design of the ATL rotor blade ice protection system; some of these changes have reduced the "traditional" advantages attributed to chordwise shedding. As discussed previously the effect of kinetic heating reduces the electrical power required to deice the outboard area of a rotor blade. A deicer boot constructed with a variable power density takes advantage of kinetic heating and consumes less electrical power than one designed with a constant density. Also, with a variable density, there is less overheating at the tip, reducing the chance of runback. Chordwise heater elements (i.e., spanwise shedding) readily lend themselves to spanwise power density variation.

Using the spanwise shedding concept, with an etched foil heater element, variable power density can be achieved by simply changing the ribbon pattern. With the chordwise shedding concept, using a knitted wire heater element typical of these installations, achieving a spanwise power density variation is very difficult. One approach would be to splice in a series of knitted wire elements, each with the desired power density, along the length of the span. The drawback to this approach is the number of solder joints, each of which is a small cold spot. Since the existence of solder joints along the blade span has traditionally been labeled a disadvantage of the spanwise shedding concept, it would also be considered so here. Although this approach has been tried on an experimental basis, no production application of variable power density, using a knitted wire element, to chordwise deicing is known.

In addition to providing a variable power density, the etched foil heater element has other advantages over wire elements. The foil element is a more efficient heater than wire in that the flat ribbon heats a wider area. The alloy used in the element can be selected to optimize fatigue life, heating efficiency, cost or some combination of these parameters. Stainless steel foil, as used in the ATL blades, is readily available; other alloys are in use on composite blades which have demonstrated a virtually unlimited fatigue life.

It is possible to design chordwise heater elements to minimize the number of electrical connections along the blade span, further reducing the differences between the spanwise and chordwise shedding concepts. In addition there is currently at least one application of spanwise heater elements in which an electrical power return braid is located at the blade tip; the centrifugal force environment for this connection is as severe as would be experienced in a chordwise element application. By the location of this braid at the tip, it is apparent that the "traditional" advantage accorded spanwise elements, by locating connectors at the root, is not inviolate.

A rough estimate of production heater blanket cost, excluding tooling and erosion shields, has been made for a retrofit application similar to that used on the ATL test helicopter. For spanwise-shedding, it is estimated that the heater blanket would cost about \$1000 per blade. This number breaks down to \$500 for the blanket itself and \$500 for bonding the blanket to the erosion shield and the whole assembly to the blade. For a chordwise shedding heater blanket, the estimate is the same. Of course, there are many variables which must be considered in establishing the final cost of either system, but this rough survey indicates that cost alone shouldn't be the overriding factor in selecting spanwise or chordwise shedding.

A very simplistic comparison of heater blanket weight was also done which shows the two designs to be fairly comparable on a weight per unit area basis. The same should hold true for maintainability; no significant difference, given equally good fabrication, would be expected for either blanket configuration.

CONCLUSIONS

The spanwise-shedding, cyclic electrothermal rotor blade deicing system has been demonstrated to be effective and reliable during the past two years of simulated and natural icing flight tests. Based on the energy on-time required for clean sheds, flight test experience has verified the economic electrical power consumption of the spanwise shedding concept. In general, the deicing system has provided clean, controlled ice shedding. The major problems experienced, electrical failures and inboard zone runback, are directly attributed to the prototype nature of the blades.

In this paper, the need for spanwise variation of power density (or on-time) has been demonstrated; the spanwise shedding concept is inherently capable of providing this variation to take advantage of kinetic heating. Data has also been presented on the effects of kinetic heating, liquid water content, and sublimation on blade surface temperature.

The possible need for a separate deicing cycle for the inboard 30% to 35% blade span, deicing half as often as the outboard span, has been discussed. Potential operational penalties and flight safety considerations, which must be further assessed, have also been described. Some limited flight experience in the Ottawa spray rig in a mixed snow and supercooled cloud environment has been documented. The rotor blade deicing system appears to be unaffected by the simulated mixed condition; however, the engine inlet barrier screen may be susceptible to blockage. These conclusions need further testing for verification.

The postulated advantage of "inherent redundancy" for the spanwise-shedding concept, which would permit continued flight with one heater zone inoperative, has been called into question by the failure of an inboard zone to shed. Further work is needed to determine if the location of the failure should be a factor in the decision to continue or abort a mission. At any

rate, if the inherent redundancy concept should prove to be invalid, a single-zone failure of a chordwise heater element would not be more damaging than a single zone failure in a spanwise element.

The choice between spanwise or chordwise shedding is up to the designer, who must weigh the many factors which affect the system design and selection of components. Evolution of electrothermal technology has reduced many of the traditional advantages which chordwise shedding had over spanwise shedding. The ease with which spanwise shedding accommodates kinetic heating effects remains an advantage of this system over chordwise shedding. The experience described in this paper documents the effectiveness of the spanwise shedding concept for rotor blade deicing.

REFERENCES

1. Adams, R. I., US DEVELOPMENTS IN THE AREA OF HELICOPTER ICE PROTECTION, to be presented to the NATO AC/225 (Panel X) Helicopter Icing Symposium, London, England, on 7 November 1978.
2. Werner, J. B., ICE PROTECTION INVESTIGATION FOR ADVANCED ROTARY-WING AIRCRAFT, USAAMRDL-TR-73-38, Eustis Directorate, US Army Air Mobility Research and Development Laboratory, Fort Eustis, Virginia, August 1973, AD 771182.
3. Cotton, R. H., ICING TESTS OF A UH-1H HELICOPTER WITH AN ELECTROTHERMAL ICE PROTECTION SYSTEM UNDER SIMULATED AND NATURAL ICING CONDITIONS, USARTL-TR-78-48, Applied Technology Laboratory, US Army Research and Technology Laboratories (AVRADCOM), Fort Eustis, Virginia, to be published.
4. Kitchens, P. F., and Adams, R. I., SIMULATED AND NATURAL ICING TESTS OF AN ICE-PROTECTED UH-1H, Preprint Number 77.33-25, presented at the 33rd Annual National Forum of the American Helicopter Society, Washington, D. C., May 1977.
5. Stallabrass, J. R., and GIBBARD, G. A., A COMPARISON BETWEEN SPANWISE AND CHORDWISE SHEDDING METHODS OF HELICOPTER ROTOR BLADE DEICING, Aeronautical Report LR 270, National Research Council of Canada, Ottawa, Canada, January 1960.
6. Lazelle, B. D., SOME THOUGHTS ON HELICOPTER ICE PROTECTION SYSTEMS, presented to the International Helicopter Icing Conference, Ottawa, Canada, 23-26 May 1972.
7. Adams, R. I., TECHNOLOGY AND FEASIBILITY ASSESSMENT FOR ICE PROTECTION OF EXISTING ARMY HELICOPTERS, prepared 1 November 1974, presented to the USA Training and Doctrine Command Seminar on Helicopter Ice Protection, Fort Rucker, Alabama, on 3 February 1977.
8. Werner, J. B., THE DEVELOPMENT OF AN ADVANCED ANTI-ICING/DEICING CAPABILITY FOR US ARMY HELICOPTERS, VOLUME I - DESIGN CRITERIA AND TECHNOLOGY CONSIDERATIONS, USAAMRDL-TR-75-34A, Eustis Directorate, US Army Air Mobility Research and Development Laboratory, Fort Eustis, Virginia, November 1975, AD A019044.
9. Werner, J. B., THE DEVELOPMENT OF AN ADVANCED ANTI-ICING/DEICING CAPABILITY FOR US ARMY HELICOPTERS, VOLUME II - ICE PROTECTION SYSTEM APPLICATION TO THE UH-1H HELICOPTER, USAAMRDL-TR-75-34B, Eustis Directorate, US Army Air Mobility Research and Development Laboratory, Fort Eustis, Virginia, November 1975, AD A019049.

10. Cotton, R. H., OTTAWA SPRAY RIG TESTS OF AN ICE PROTECTION SYSTEM APPLIED TO THE UH-1H HELICOPTER, USAAMRDL-TR-76-32, Eustis Directorate, US Army Air Mobility Research and Development Laboratory, Fort Eustis, Virginia, November 1976, AD A034458.
11. Cotton, R. H., NATURAL ICING FLIGHT TESTS AND ADDITIONAL SIMULATED ICING TESTS OF A UH-1H HELICOPTER INCORPORATING AN ELECTROTHERMAL ICE PROTECTION SYSTEM, USAAMRDL-TR-77-36, Applied Technology Laboratory, US Army Research and Technology Laboratories (AVRADCOM), Fort Eustis, Virginia, July 1978.

TABLE 1. UH-1H ICE PROTECTION SYSTEM WEIGHT

| Component | 1973 | 1974 (Ref 7) | | 1978 (Ref 1) | |
|--|---|--|--|--|--|
| | Prototype Deicing System Actual Weight(Pounds) | Production System Estimated Weight (Pounds) | Production System Estimated Weight (Pounds) | Production System Estimated Weight (Pounds) | Production System Estimated Weight (Pounds) |
| 1. Main rotor & stabilizer bar heater blankets | 43 | 40 | | 0 | 0 |
| 2. Tail rotor heater blankets | 3 | 0 | | 0 | 0 |
| 3. Timer/controller & stepping switch | 24 | 15 | | 23 | 23 |
| 4. Glass windshields | 34 | 37 | | 0 | 0 |
| 5. Main & tail rotor sliprings | 25 | 10 | | 12 | 12 |
| 6. Cockpit control panel | 6 | 5 | | 0 | 0 |
| 7. Ice detectors (2) and OAT probes | 9 | 5 | | 0 | 0 |
| 8. Wiring, relays, circuit breakers, etc. | 95 | 70 | | 35 | 35 |
| 9. Change to AC generator, voltage regulator | 23 | -17 | | -1 | -1 |
| 10. Transformer/rectifier | 17 | -- | | -- | -- |
| TOTAL WEIGHT | 279 | 165 | | 69 | 69 |
| Flight Test Instrumentation | 567 | | | | |
| Total UH-1H Weight Change | 846 | | | | |

TABLE 2. HEATER BLANKET COMPONENT SELECTION

| Component | Desired Qualities | Configurations Considered |
|----------------|---|---|
| Erosion Shield | <p>Erosion resistance - rain, snow, sand Strike tolerance High heat transfer rate Durability Reliability Structural behavior Cost Producibility (thickness, tapering, forming, preparation for adhesive bonding)</p> | <ol style="list-style-type: none"> 1. Nickel - rolled - hard electroformed - soft electroformed 2. Stainless steel 3. Titanium |
| Heater Element | <p>Good control of cross-section for uniform heating High thermal efficiency Ductility Fatigue resistance Durability Damage tolerance Repairability High strain capability (for composite blades)</p> | <ol style="list-style-type: none"> 1. Etched metal foil grid 2. Sprayed metal grid 3. Knitted metal wire in glass fabric 4. Pierced expanded metal grid 5. Wire imbedded in rubber |
| Insulation | <p>Ease of fabrication High dielectric strength Minimum thickness High heat transfer rate High resistance to centrifugal force and dynamic moments Long fatigue life Good tolerance to chemical environment</p> | <ol style="list-style-type: none"> 1. Tedlar film with 1 ply of 108 style glass fabric impregnated with nitrile phenolic resin 2. 2 plies 106 style glass fabric impregnated with polyimide resin (or equivalent) 3. 2 plies 106 style glass fabric impregnated with epoxy resin (or equivalent) |

TABLE 3. GENERAL QUALITY CONTROL PROCEDURES

| | | |
|--------------------------------|---|--|
| MATERIAL CONTROL | - | Testing adhesives and prepregs |
| | | Conformance with specifications & storage requirements |
| | | Shelf life |
| EQUIPMENT & FACILITIES CONTROL | - | Testing bonding chemicals |
| | | Concentration |
| | | Temperature |
| | | Work Areas |
| | | Temperature |
| | | Humidity |
| | | Ovens & Autoclaves |
| | | Heating uniformity |
| | | Instrumentation accuracy |
| CURE CYCLES | - | Record & verify within process specifications |
| | | Temperature |
| | | Time |
| | | Pressure, vacuum |
| SURVEILLANCE | - | Verify conformance |
| | | Procedures |
| | | Tag end coupons |

TABLE 4 - SUMMARY OF TESTS - DEICER BOOT CONFIGURATION

| Configuration | Tests |
|--|---|
| <p>Configuration 1</p> <p>Nickel 0.020 Nitrile Phenolic Adhesive 0.006 Glass Fabric/Phenolic 0.004 Nitrile Phenolic Adhesive 0.001 Tedlar 0.002 Nitrile Phenolic Adhesive 0.001 Stainless Steel 0.005 Glass Fabric/Epoxy 0.005</p> <p>Configuration 2</p> <p>Nickel 0.020 Nitrile Phenolic Adhesive 0.006 Glass Fabric/Polyimide 0.005 Nitrile Phenolic Adhesive 0.001 Stainless Steel 0.005 Glass Fabric/Epoxy 0.005</p> <p>Configuration 3</p> <p>Nickel 0.020 Epoxy Adhesive 0.006 Glass Fabric/Epoxy 0.003 Epoxy Adhesive 0.001 Stainless Steel 0.005 Glass Fabric/Epoxy 0.005</p> | <p>Dielectric Strength</p> <p>Resistance - megohms Breakdown - 1250 volts</p> <p>Heat Test-Seconds To Melt 150°F Tempilaq. 20 watts/sq in. 15 watts/sq in. 10 watts/sq in.</p> <p>Bond Strength</p> <p>Peel-lb /in. Failure Location</p> <p>Tensile-psi Failure Location</p> <p>Shear-psi Failure Location</p> <p style="text-align: right;">Average Values</p> |
| <p>Configuration 4</p> <p>Hardback Shield (both nickel and steel) Selected Heater Laminate Epoxy Adhesive 2024T3 Aluminum Epoxy Adhesive Selected Heater Laminate Shield</p> <p>Configuration 5</p> <p>Softback Shield Selected Heater Laminate Nylon Rubber Interlayer Modified Epoxy Adhesive 2024T3 Aluminum Modified Epoxy Adhesive Nylon Rubber Interlayer Selected Heater Laminate Shield (both nickel and steel)</p> | <p>Tension Cycling test Humidity tolerance test</p> <p>For configurations 4 and 5, material thicknesses between the heater element and the shield are the same as in configuration 3.</p> |
| <p>Configuration 6</p> <p>Hardback - Same materials and stacking order as Configuration 4 above except shields are fabricated from 020 electroformed nickel only.</p> <p>Configuration 7</p> <p>Softback - Same materials and stacking order as Configuration 5 above except shields are fabricated for 0.020 electroformed nickel only.</p> | <p>Fatigue tests</p> |

TABLE 5 - MATERIAL CONFIGURATION SELECTIONS

BASIS: TEST AND/OR PROVEN PERFORMANCE

| Heater Installation Component | Selection |
|-------------------------------|---|
| Erosion Shield | Main Rotor Outboard - 0.030 Inch 301-1/4 Stainless Steel Main Rotor Inboard - 0.016 Inch 7075T6 Clad Aluminum Tail Rotor - Electroformed Nickel Tapered 0.030 - 0.010 Inch |
| Adhesive | 0.005 Inch Nitrile Phenolic Film Adhesive |
| Insulation | 0.005 Inch Glass Fabric/Epoxy |
| Heating Element | 0.005 Inch 301 Stainless Steel |
| Insulation | 0.040 Inch Glass Fabric/Epoxy (8 Plies Fabric, 0.005 Thick) |
| Conductors | 0.025 x 0.120 Inch Copper Wire Braid |
| Adhesive | 0.010 Inch AF126 Film Adhesive |
| Blade Cavity Filler | 0.010 Inch Style 181 Glass Fabric/Epoxy |
| Adhesive | 0.010 Inch AF126 Film Adhesive |

TABLE 6. RESULTS OF MAIN ROTOR BLADE TEARDOWN INSPECTION

- In an area with two shorts, heater element and insulation did not adhere to the erosion shield.
- At leading edge (0 to 5% chord), heater element did not adhere to backing material.
- Aft of leading edge, voids were found between the heater boot and the basic rotor blade.
- Inboard of station 176.6 glass cloth insulation appeared to be dry and devoid of resin.
- Poor solder joints connecting lead wire braids to heater element tabs.

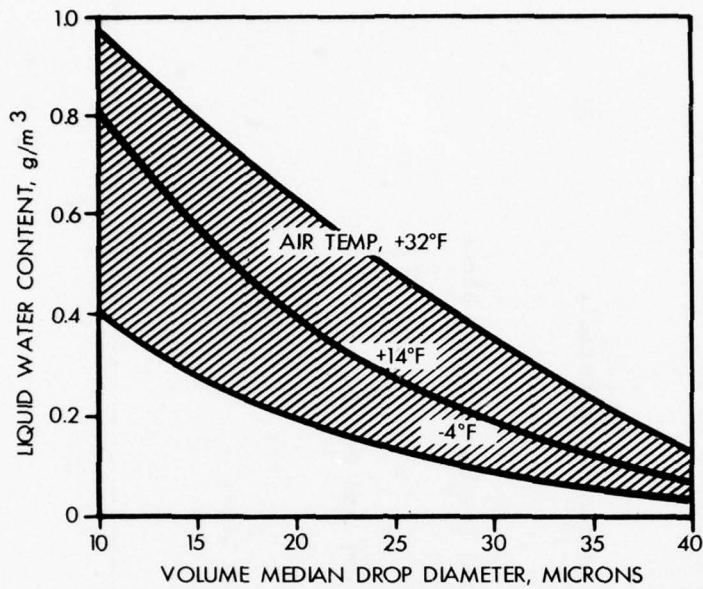

(A) CONTINUOUS MAXIMUM (STRATIFORM CLOUDS)

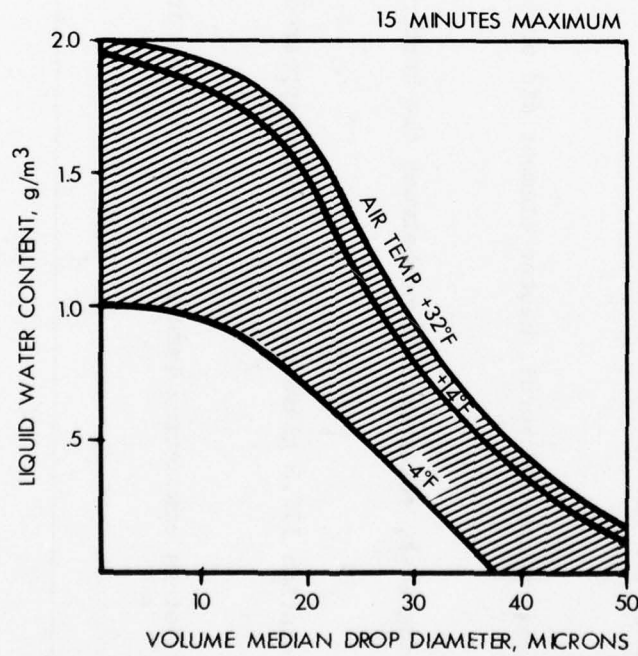

(B) INTERMITTENT MAXIMUM (CUMULIFORM CLOUDS)

Figure 1. RECOMMENDED ATMOSPHERIC ICING CRITERION

**WORLDWIDE MAXIMUM SNOWFALL LIQUID WATER CRITERIA -
99th PERCENTILE CONDITIONS.**

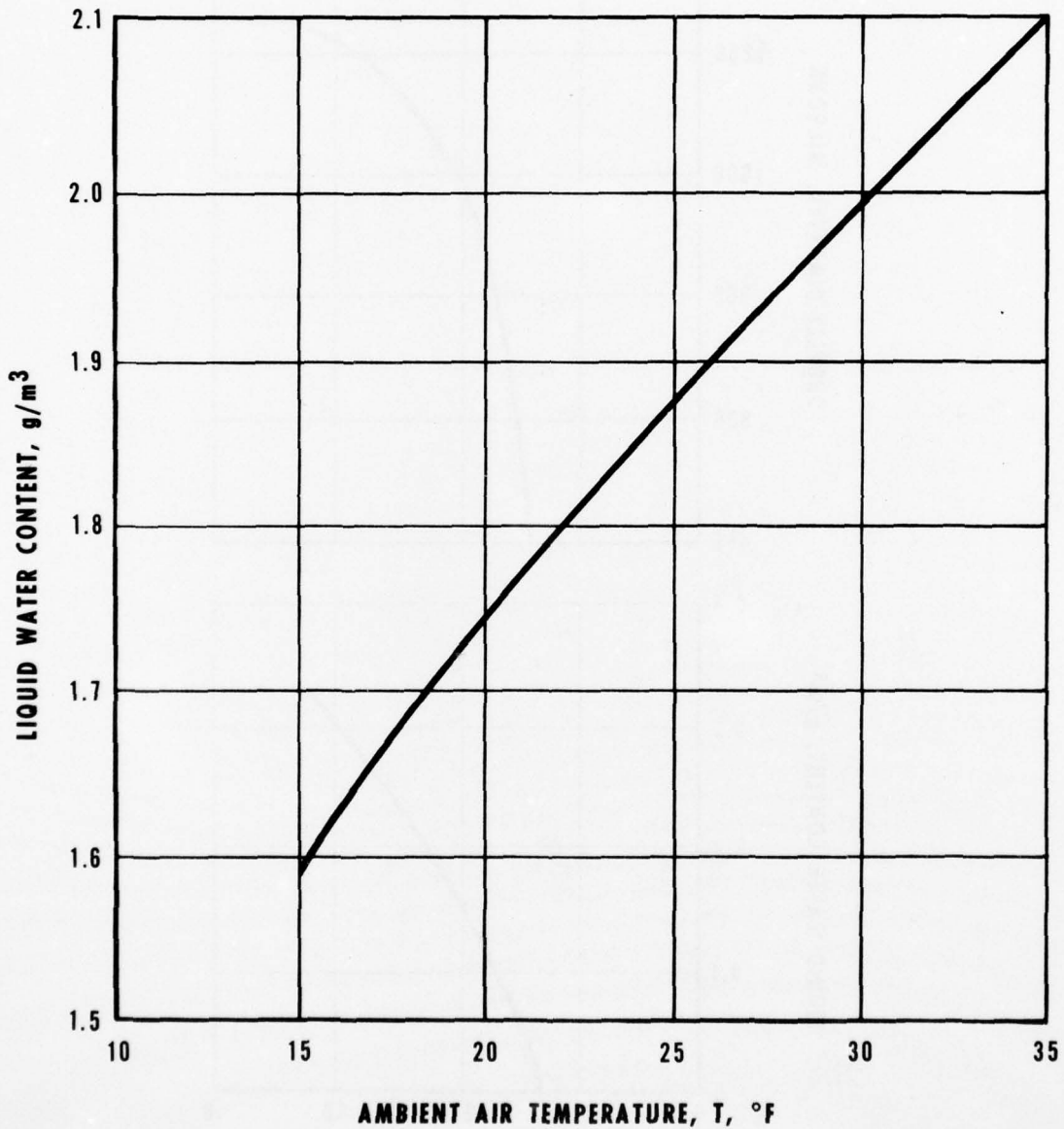

Figure 2.

FREEZING RAIN SEVERITY LEVELS - 99th PERCENTILE CONDITIONS

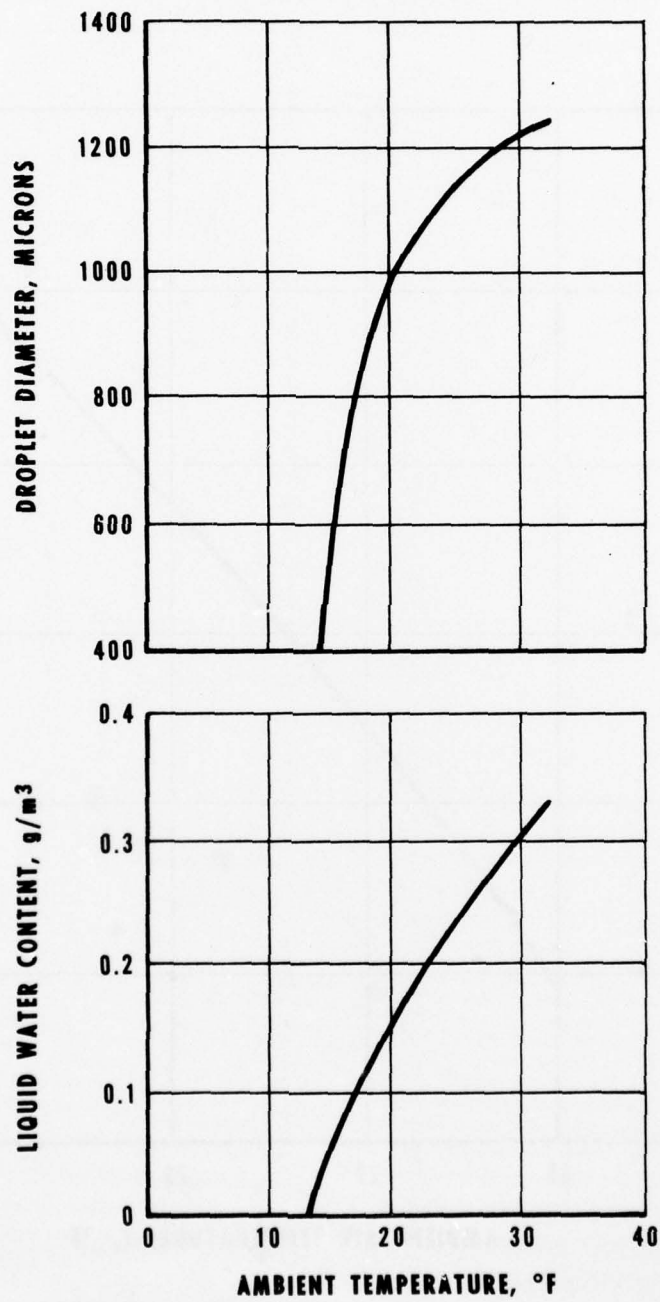

Figure 3.

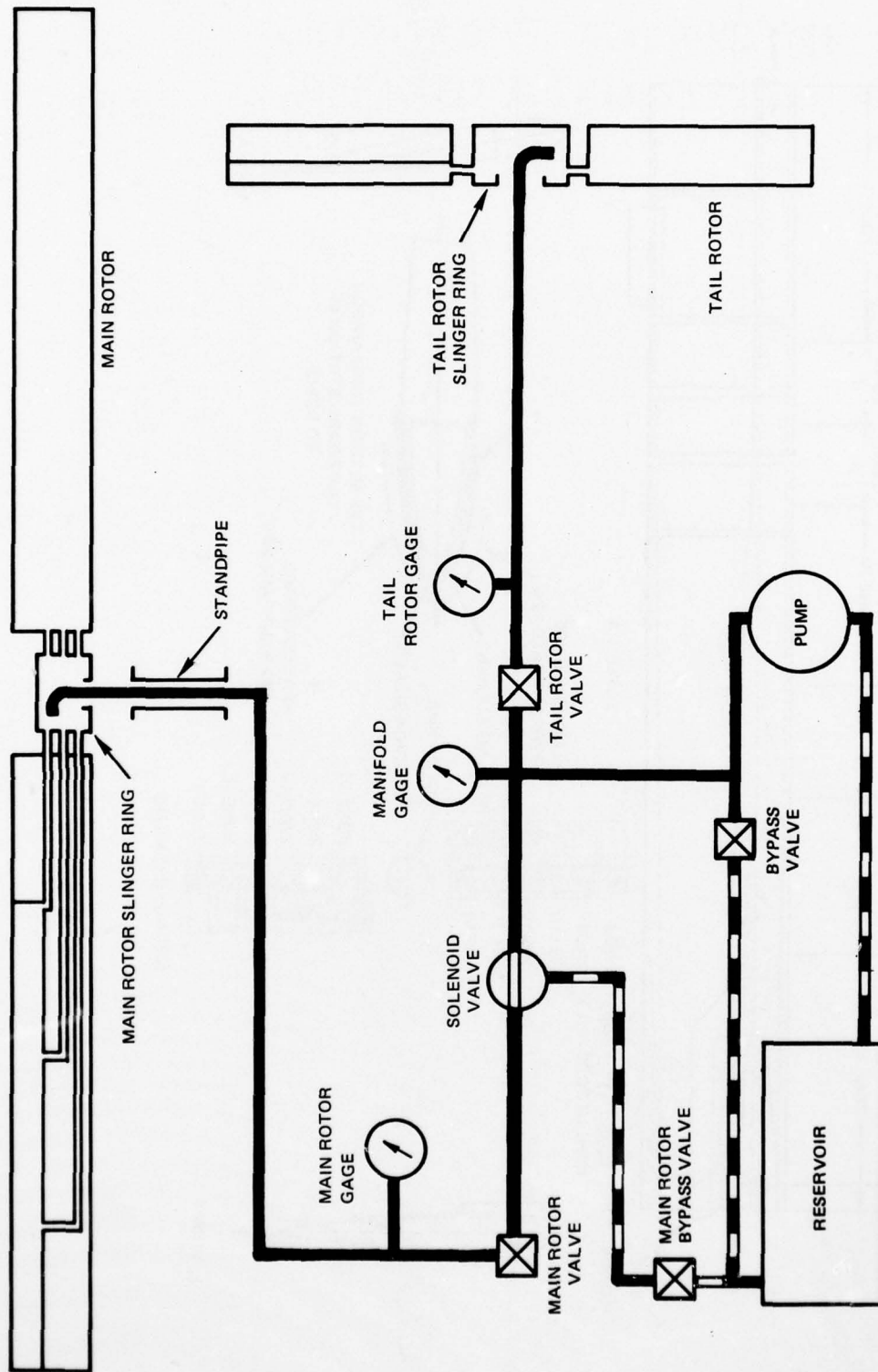

Figure 4. Schematic of Chemical Freezing Point Depressant Ice Protection System.

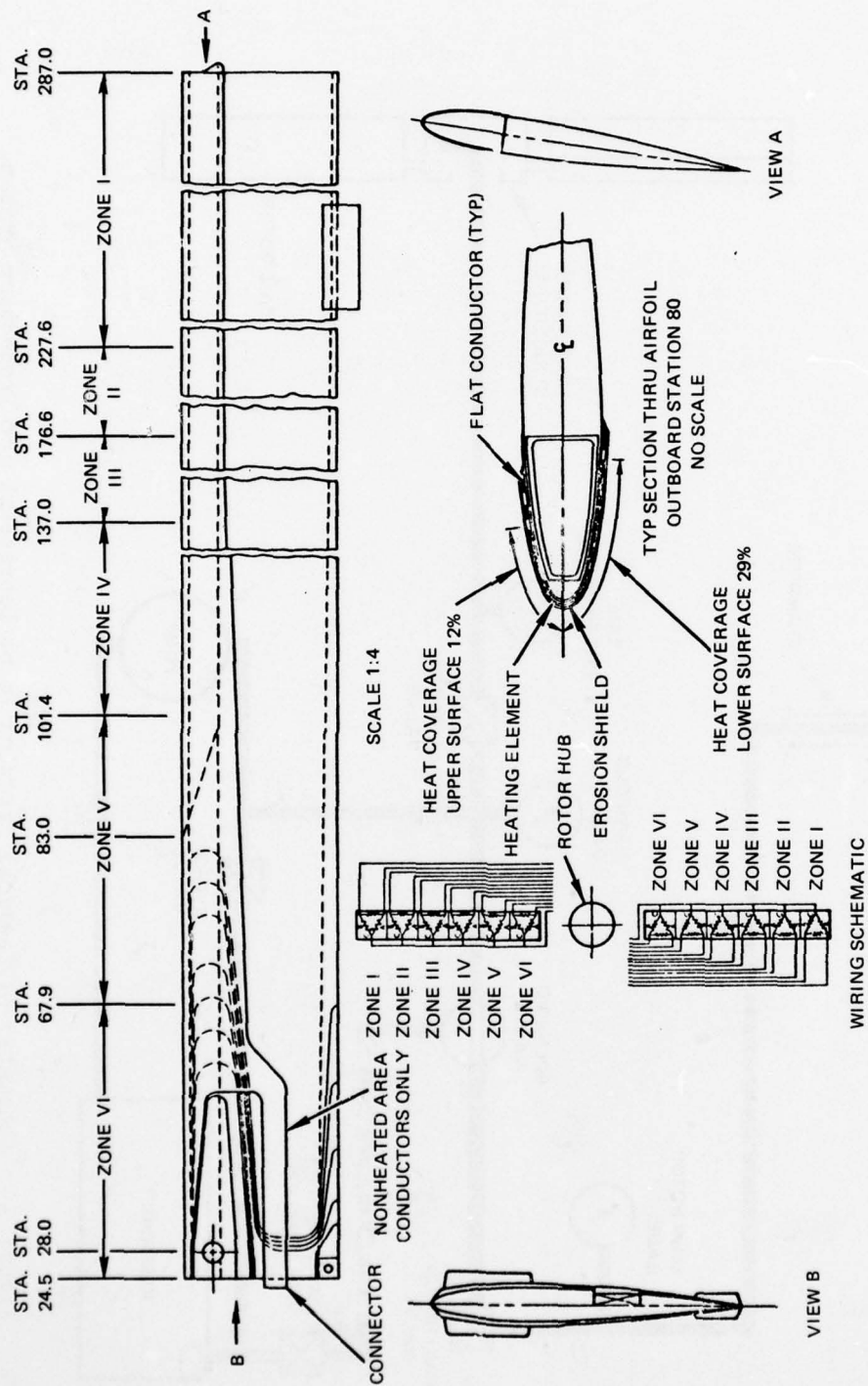

Figure 5. Main Rotor Blade Heater Blanket

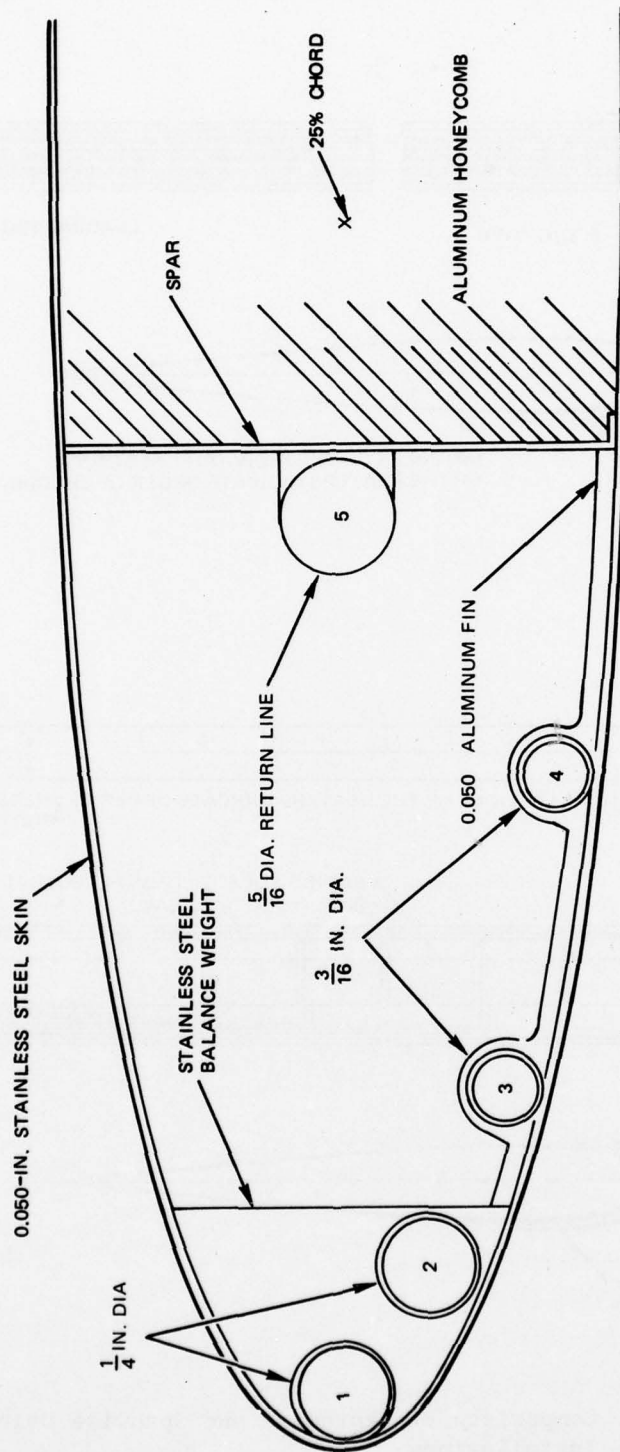

Figure 6. Typical Blade Leading-Edge Cross Section of Four-Passage Heated Liquid System.

TIP END

ROOT END

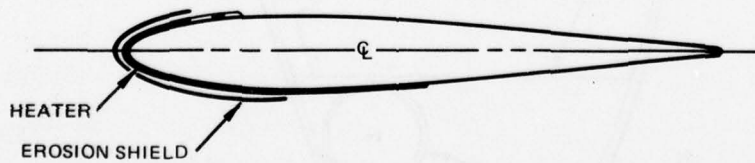
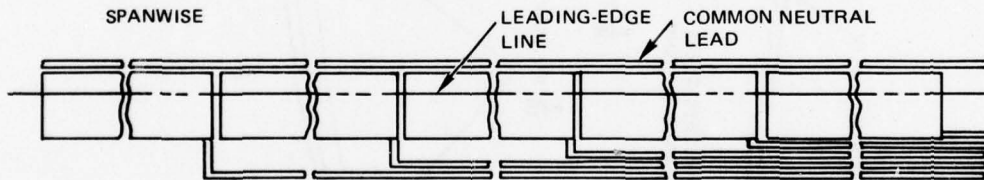
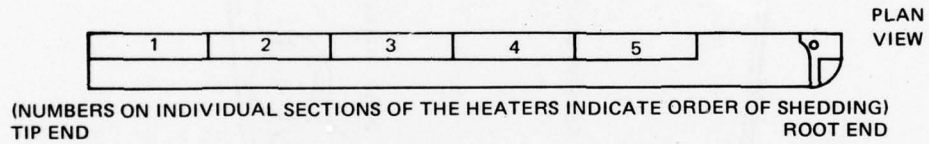
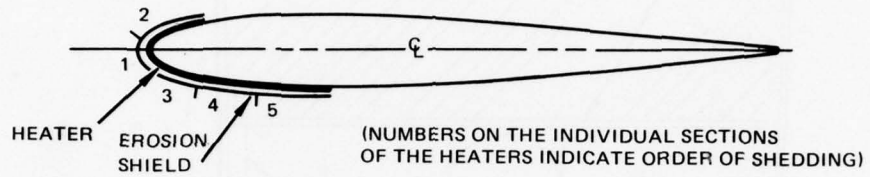
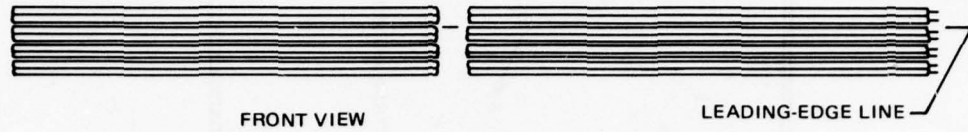

Figure 7. Comparison of Chordwise and Spanwise Deicing Installations

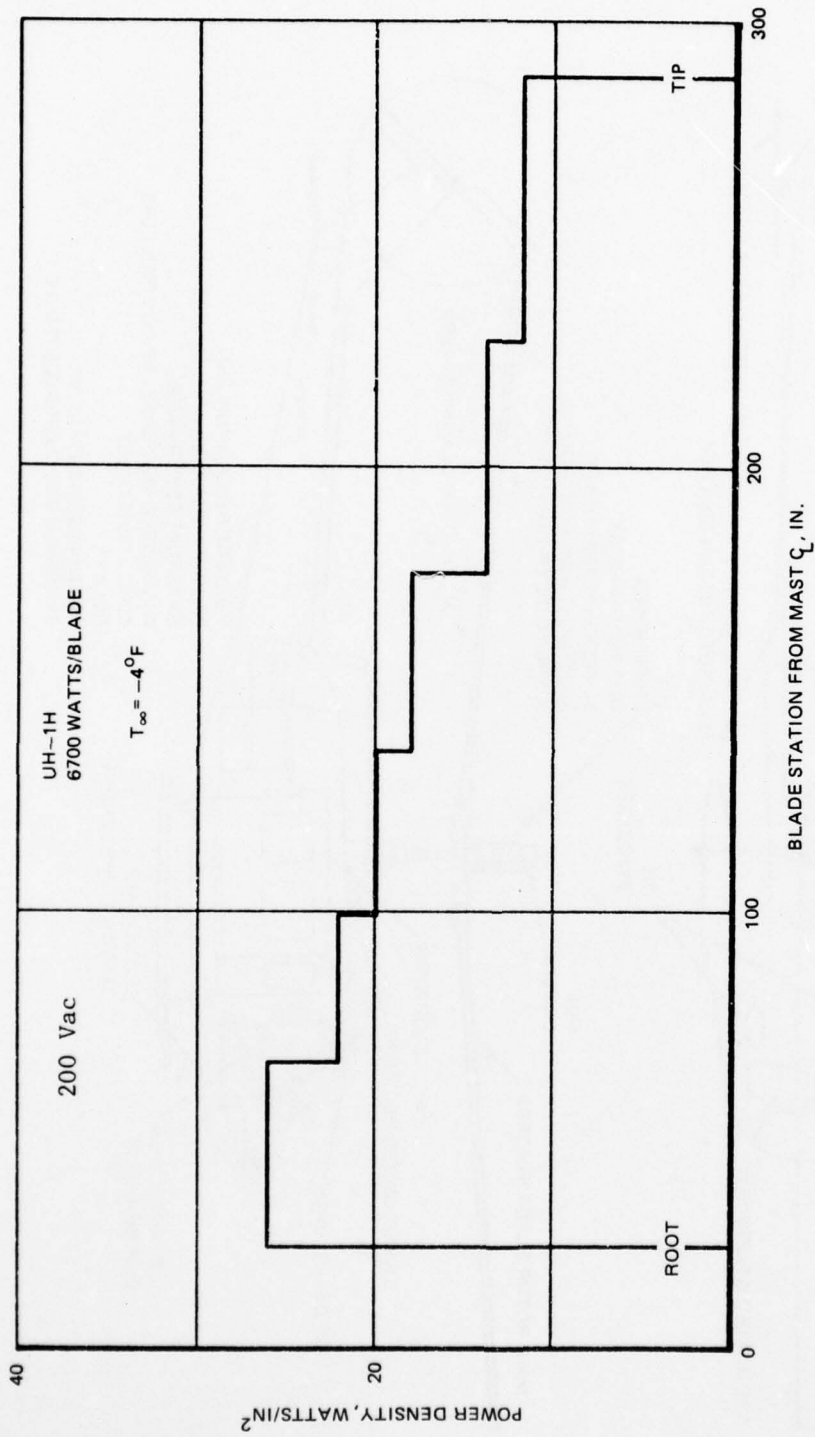
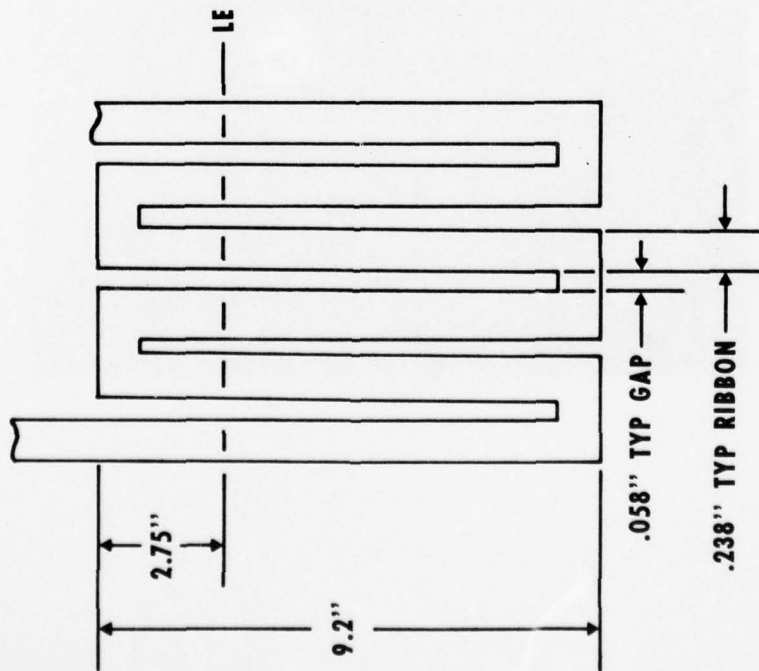

Figure 9. Main Rotor Blade Spanwise Power Density Distribution.

ORIGINAL HEATER BLANKET DESIGN

Figure 10.



OUTBOARD HEATER ELEMENT
(TYP STA 88)

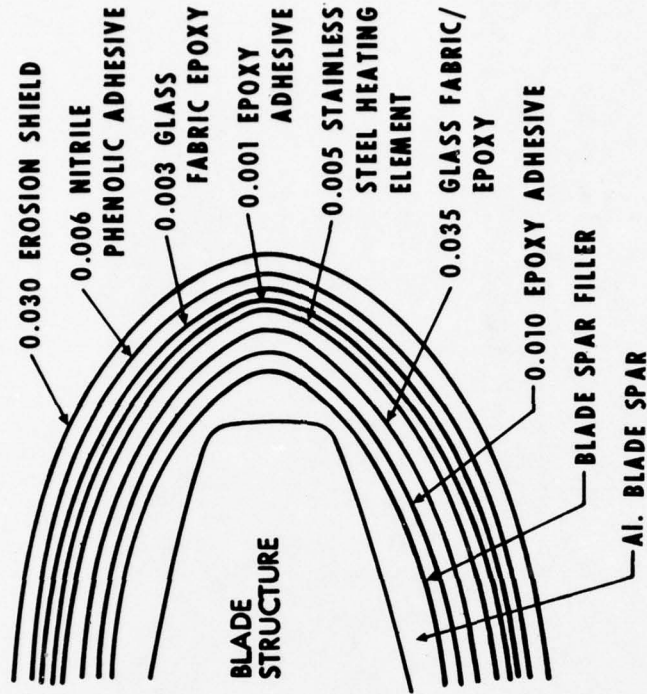

CROSS SECTION

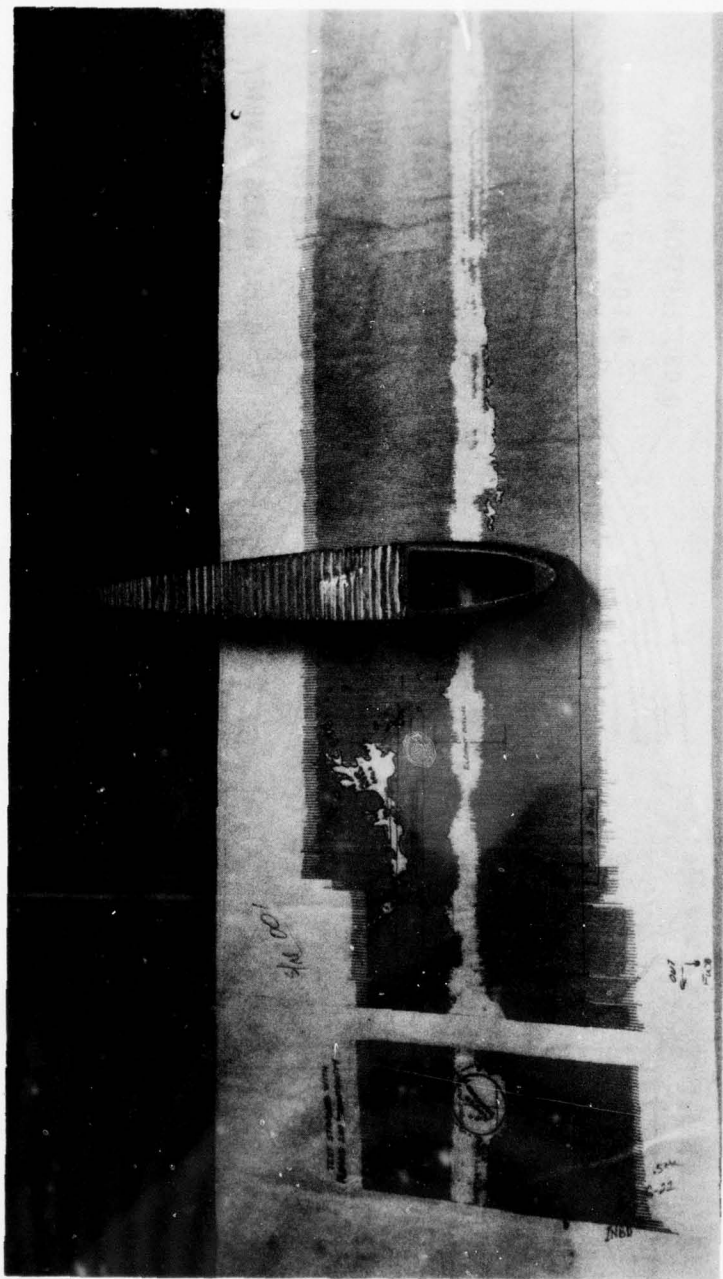

Figure 11. "C" Scan Test Signature.

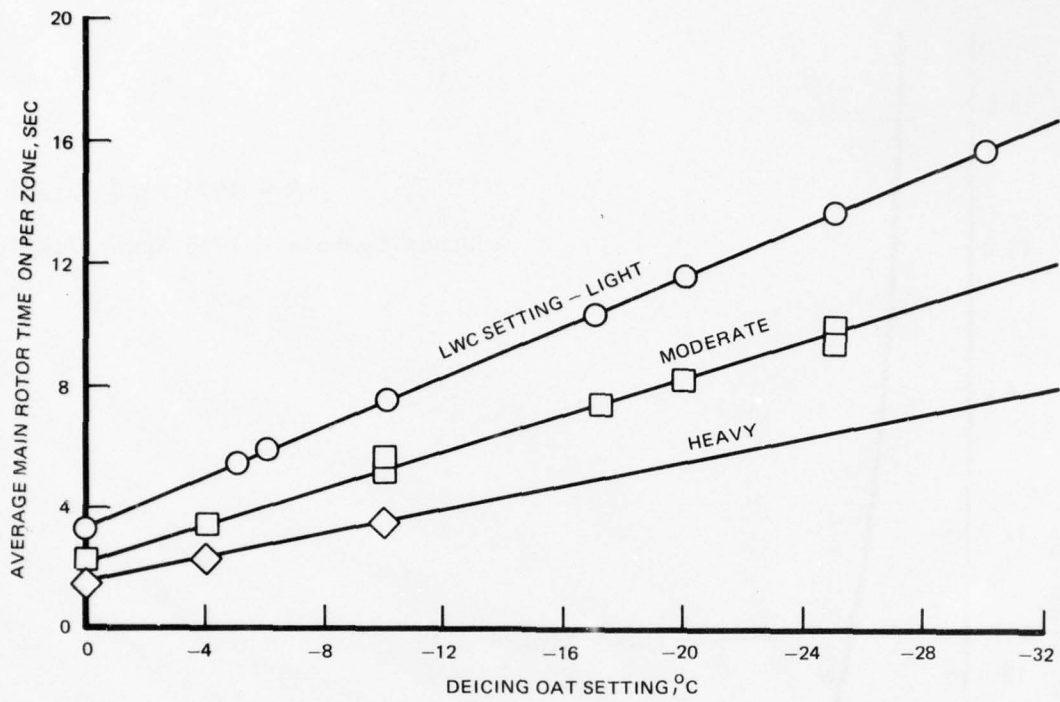

Figure 12. Original Schedule of Main Rotor Heater On-Time.

AD-A067 981

MINISTRY OF DEFENCE LONDON (ENGLAND)
HELICOPTER ICING SYMPOSIUM, 6-7 NOVEMBER 1978, LONDON, (U)
NOV 78 T C DON

F/6 1/3

UNCLASSIFIED

NL

3 of 4
AD
A067981

The image displays a grid of 120 small, high-contrast frames, likely microfilm or slide images, arranged in 10 rows and 12 columns. The frames contain various technical content related to helicopter icing, including:

- Graphs and plots showing data trends.
- Technical diagrams and schematics of helicopter components.
- Photographs of helicopter parts, possibly showing ice accumulation.
- Text-heavy frames, likely containing technical specifications or descriptions.

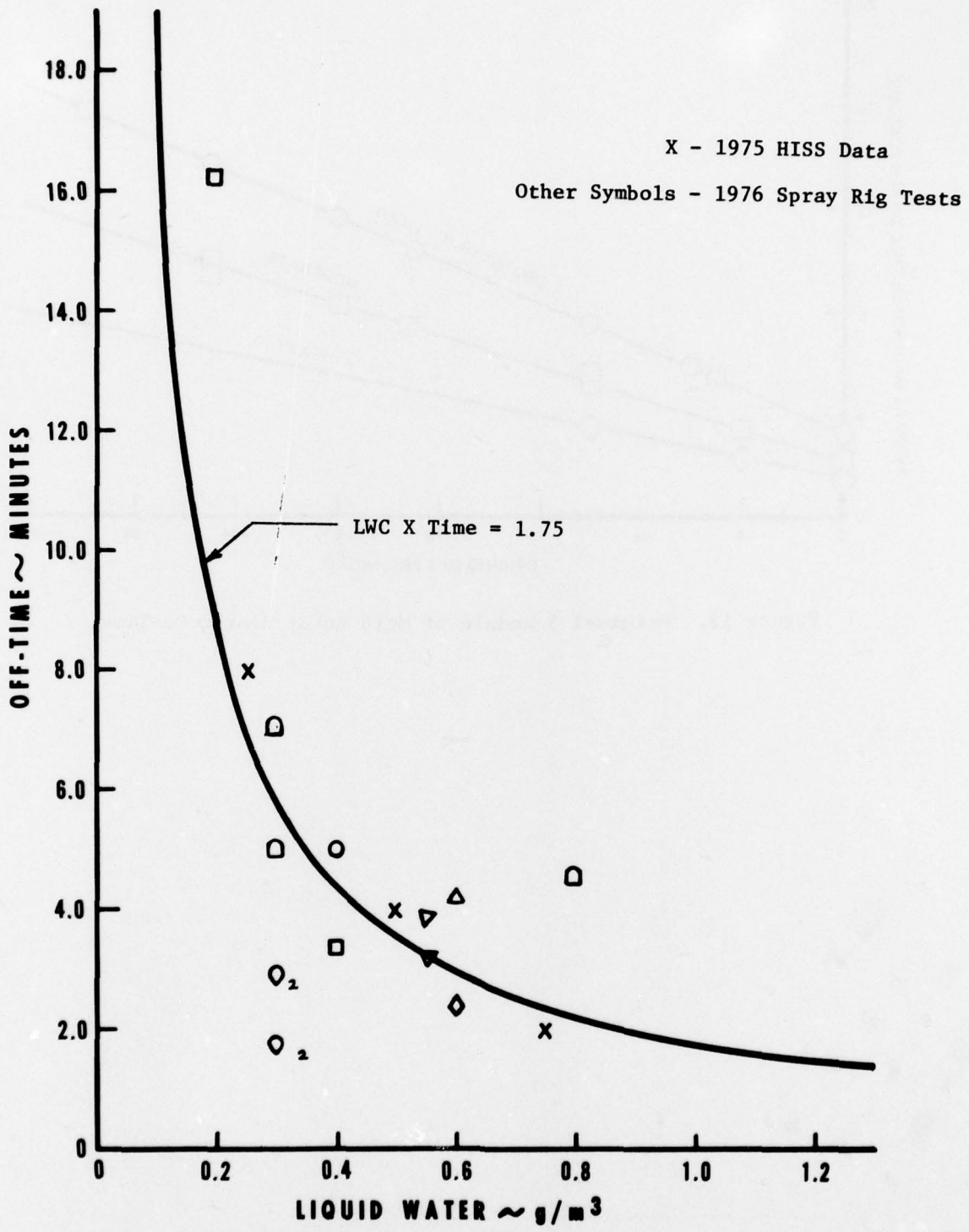

Figure 13. MAIN ROTOR OFF-TIME

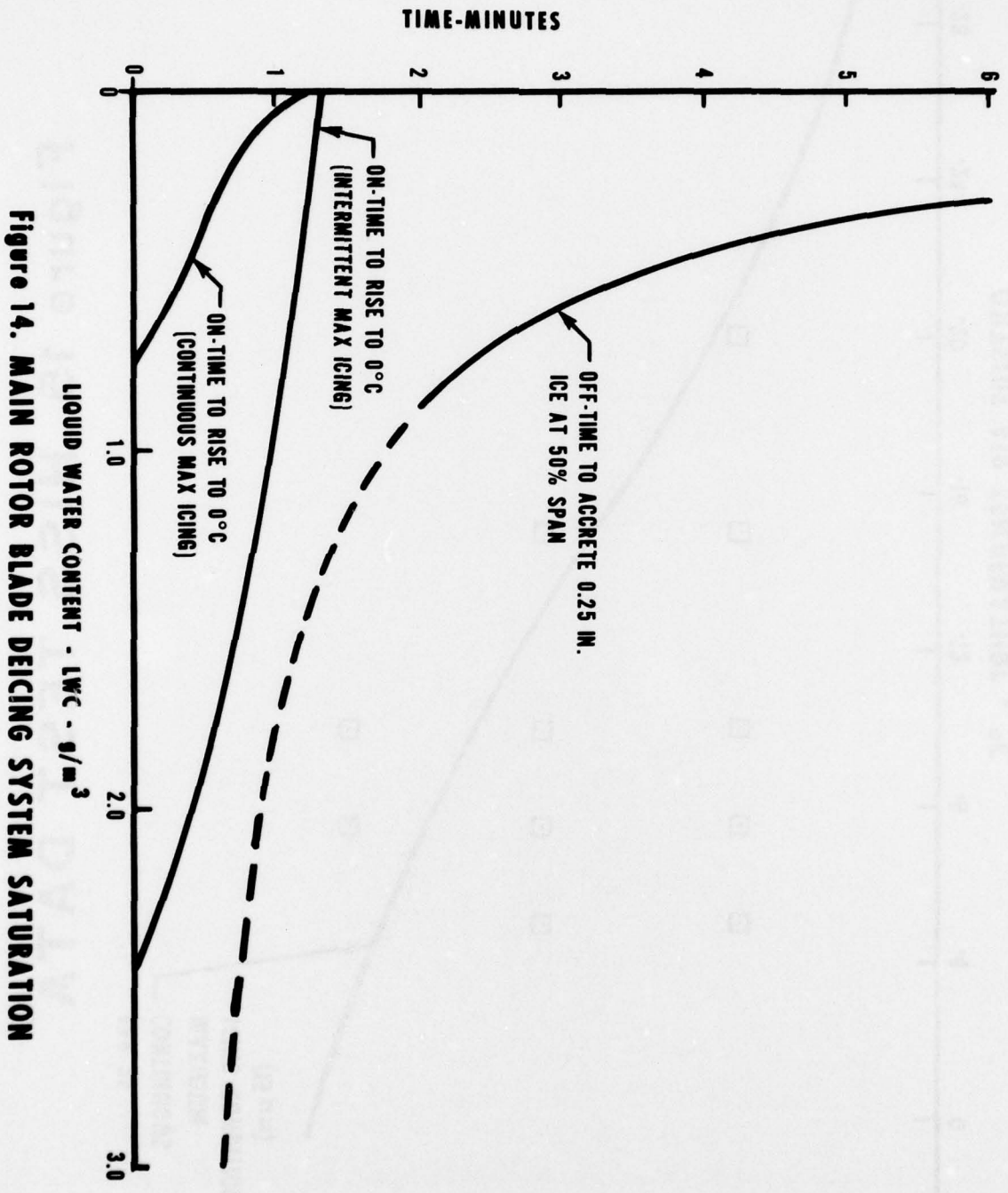
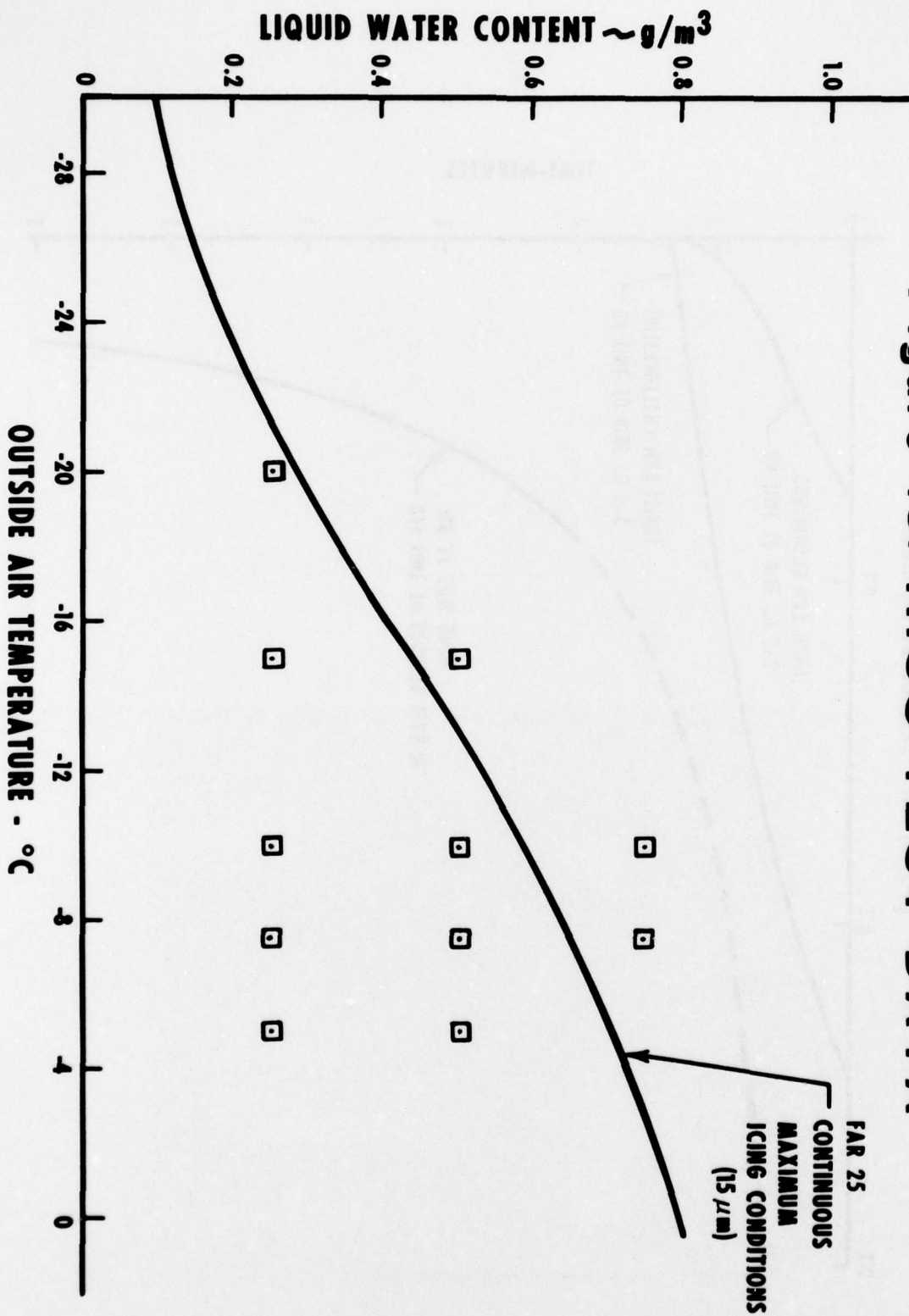

Figure 14. MAIN ROTOR BLADE DEICING SYSTEM SATURATION

Figure 15. HISS TEST DATA



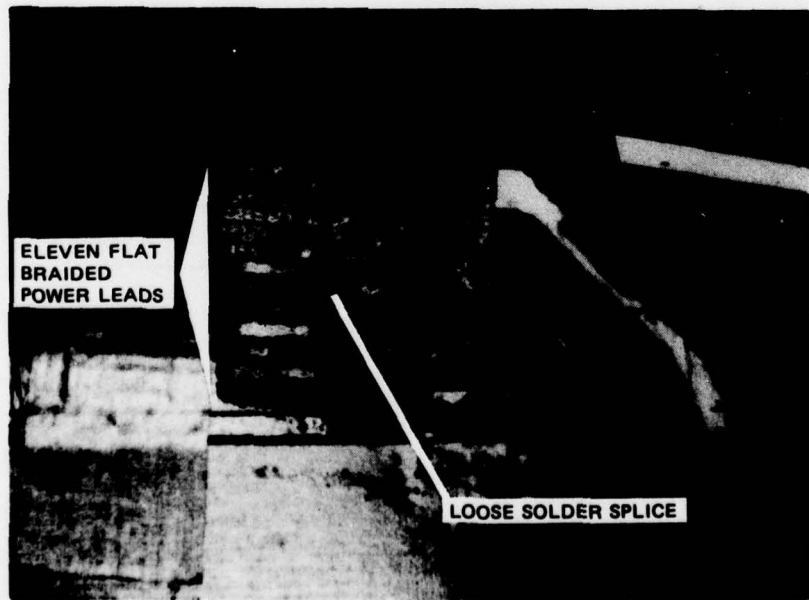
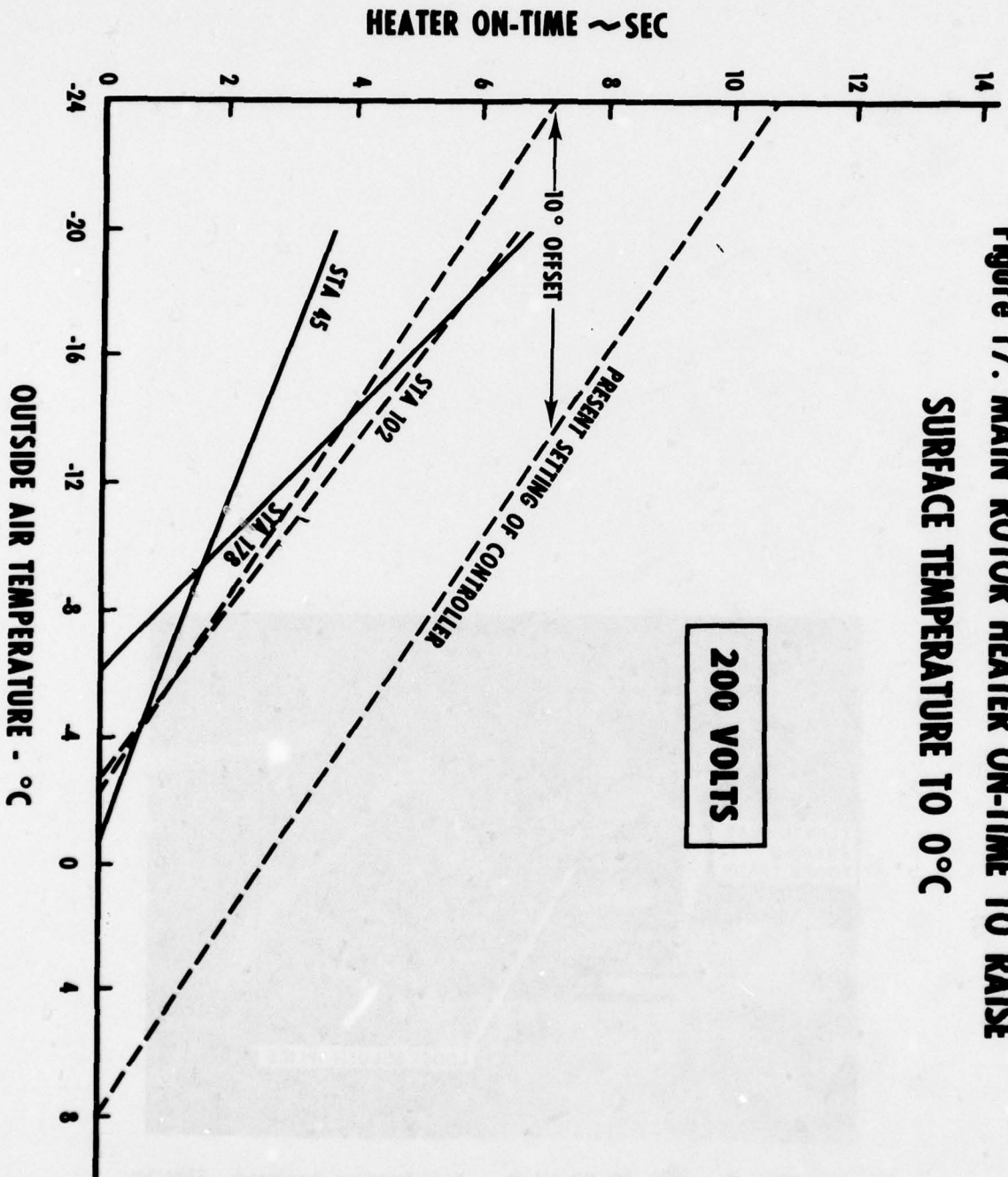

Figure 16. Station 80-83 Wiring Insulation Removed, Showing Spliced Wires and "Open" Joint That Were Found.

**Figure 17. MAIN ROTOR HEATER ON-TIME TO RAISE
SURFACE TEMPERATURE TO 0°C**



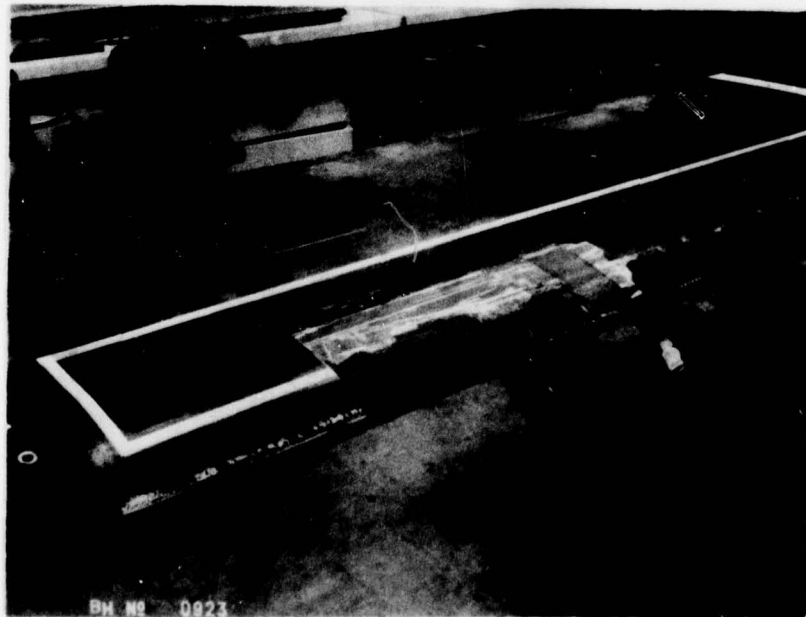
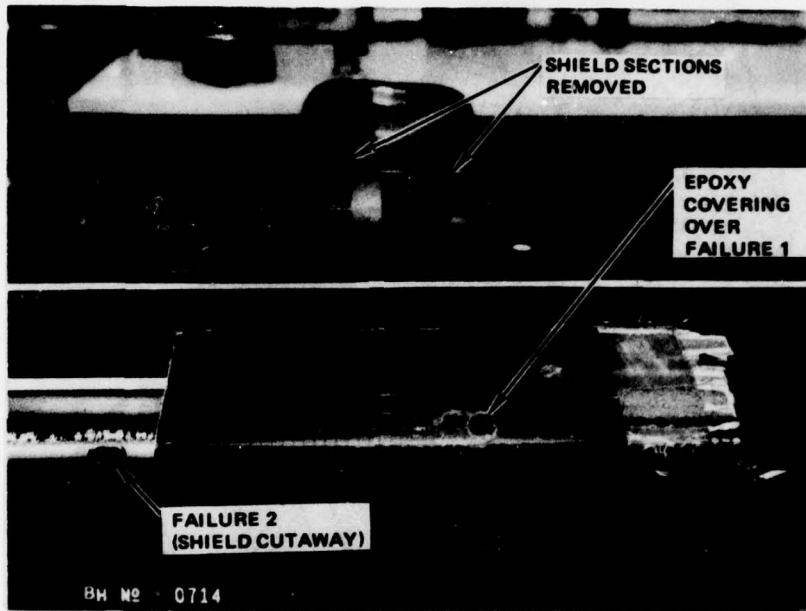

Figure 18. Results of Teardown Inspection.

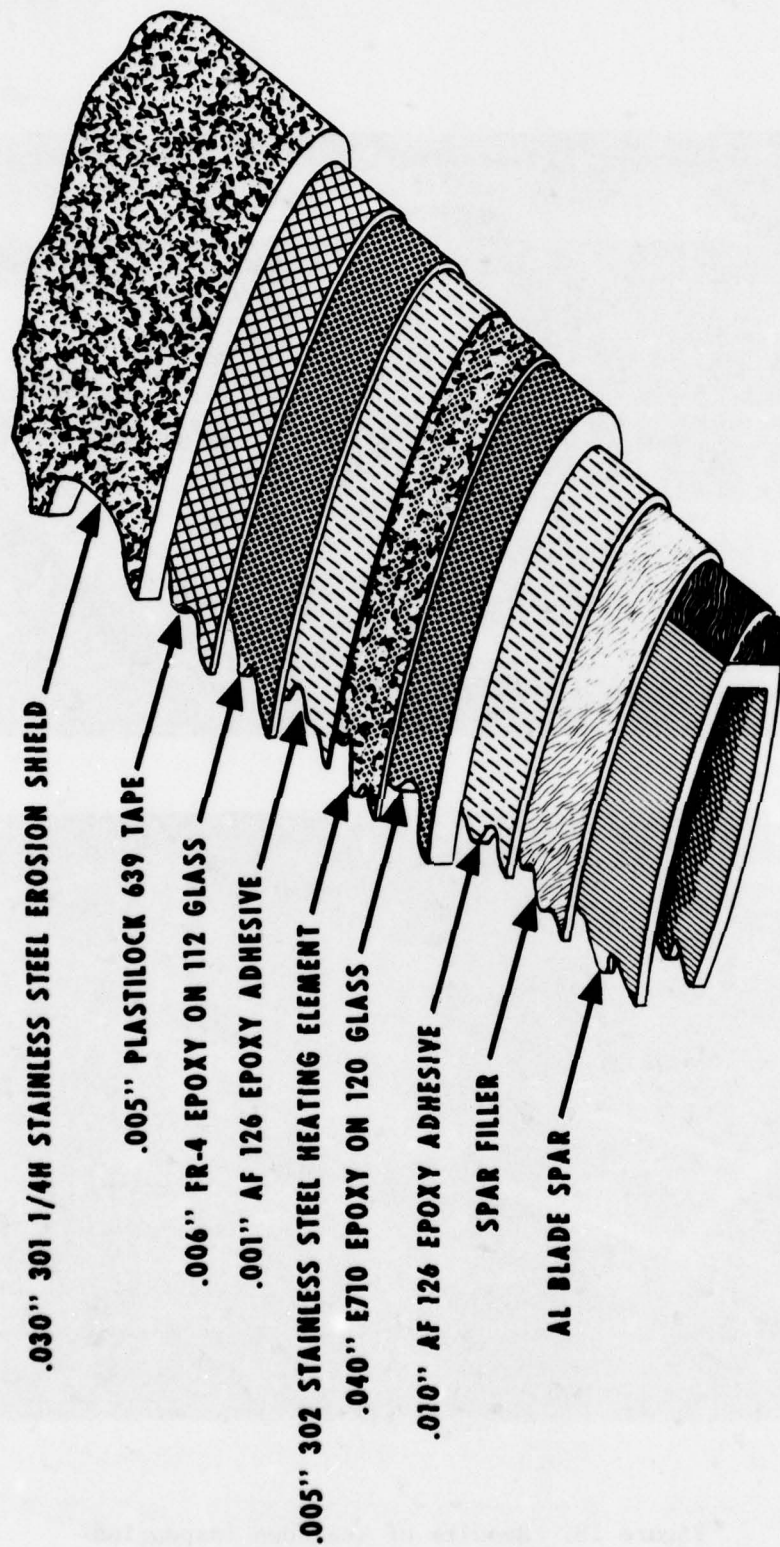

Figure 19. REDESIGNED HEATER BLANKET

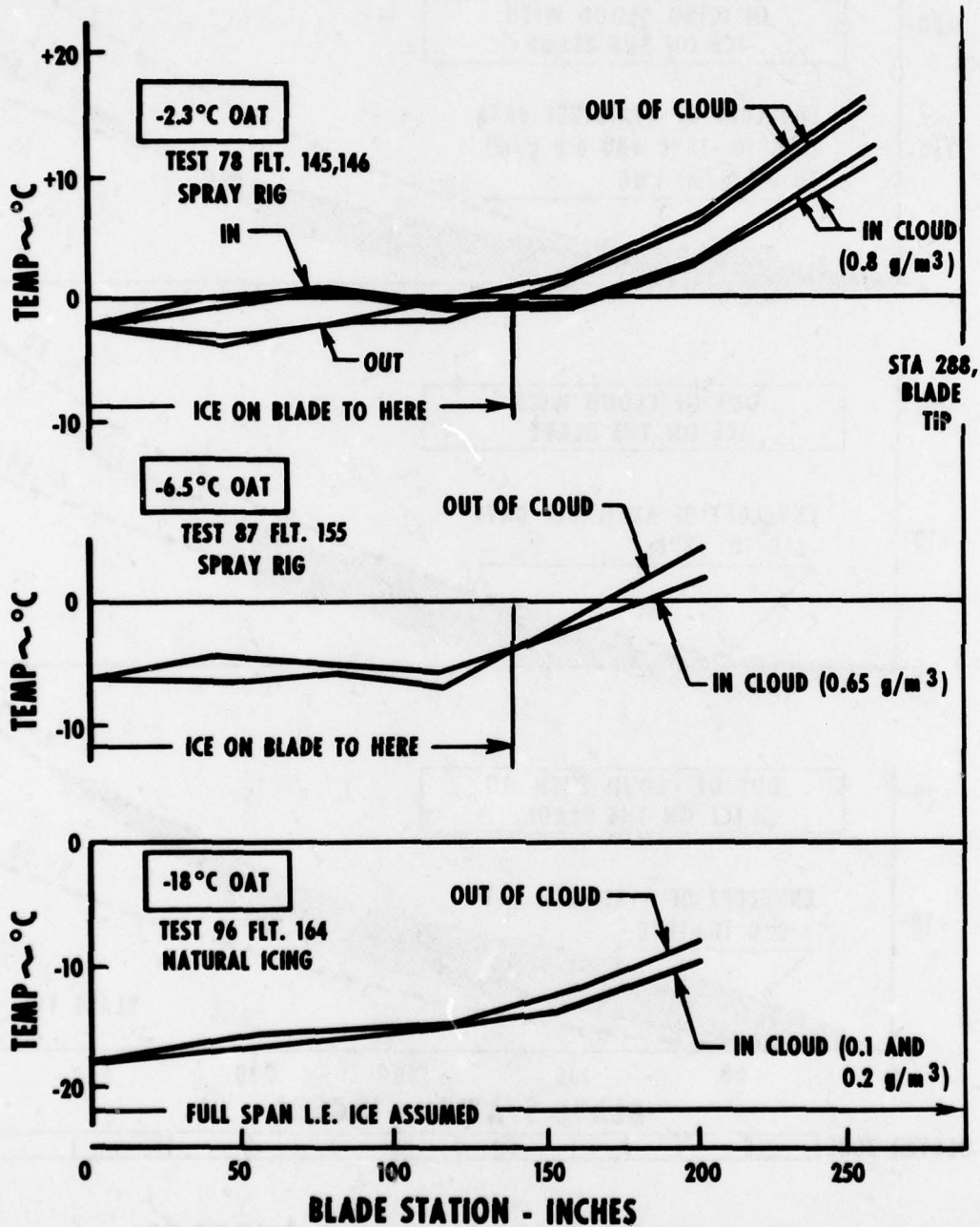

Figure 20. MAIN ROTOR BLADE SURFACE TEMPERATURE vs SPAN, IN AND OUT OF AN ICING CLOUD AT VARIOUS AIR TEMPERATURES

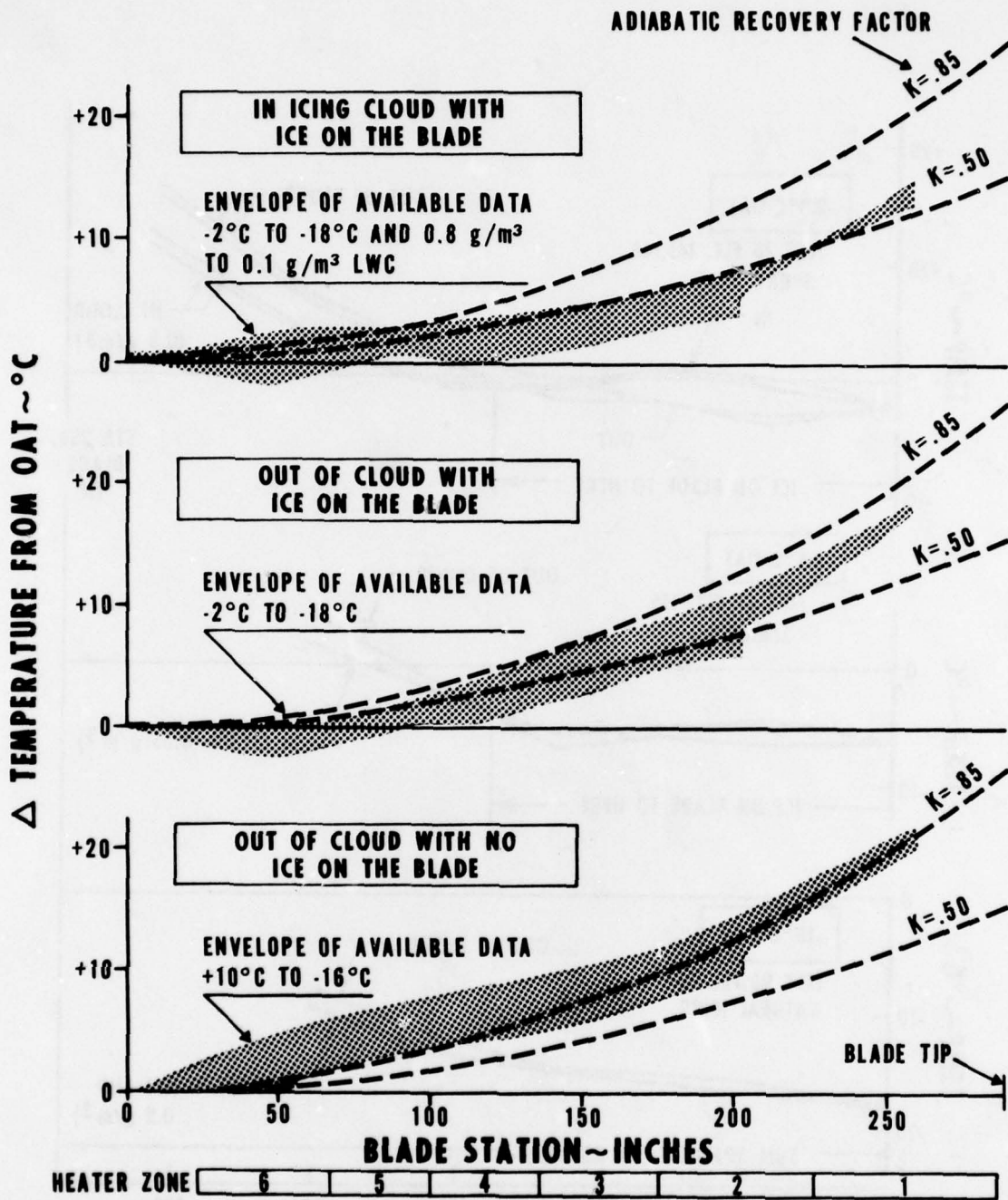

Figure 21. MAIN ROTOR BLADE SURFACE TEMPERATURE MEASURED UNDER DIFFERENT OPERATING CONDITIONS

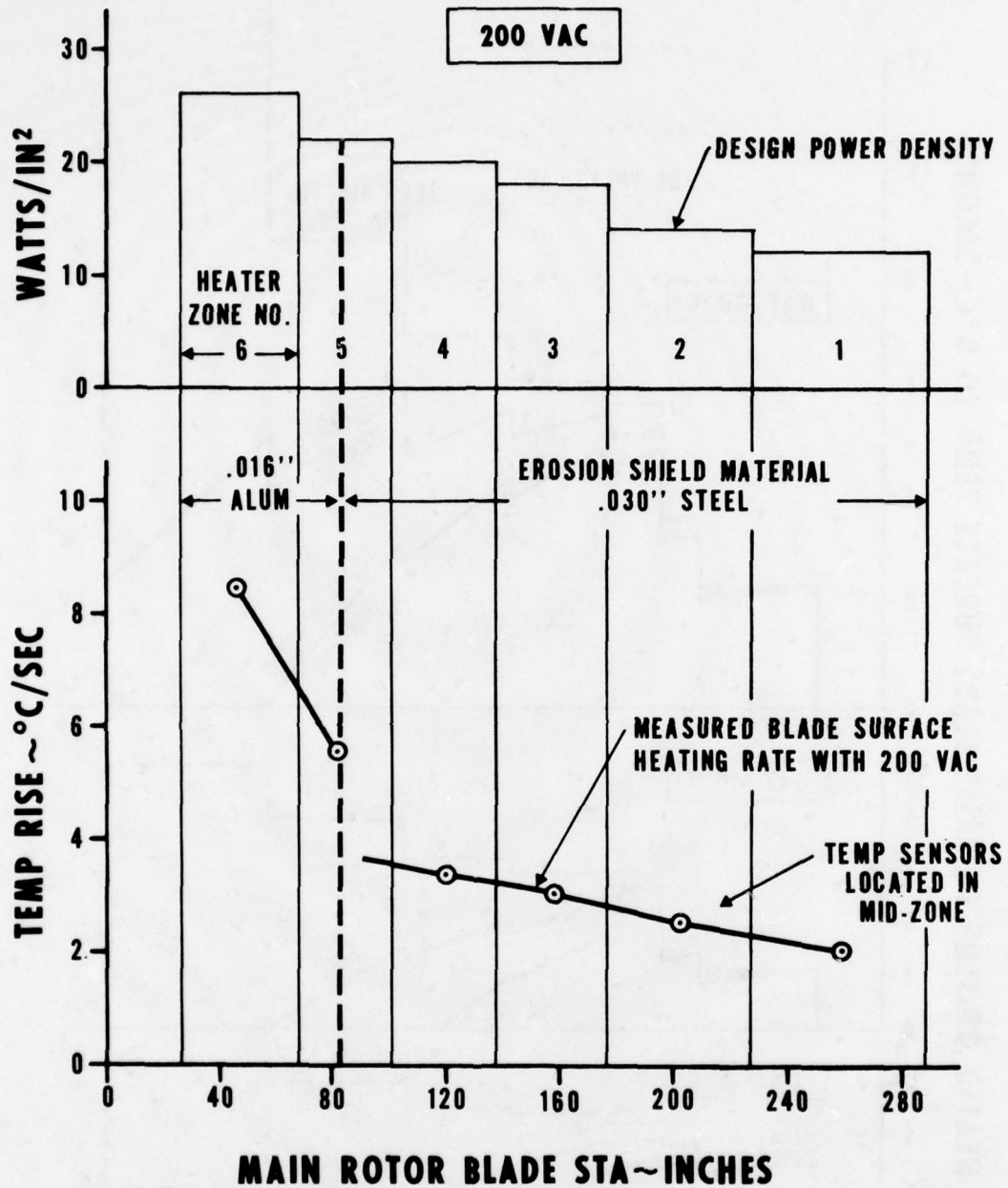

Figure 22. MAIN ROTOR BLADE SURFACE TEMPERATURE RISE PER SECOND OF HEATER-ON TIME VS BLADE SPAN

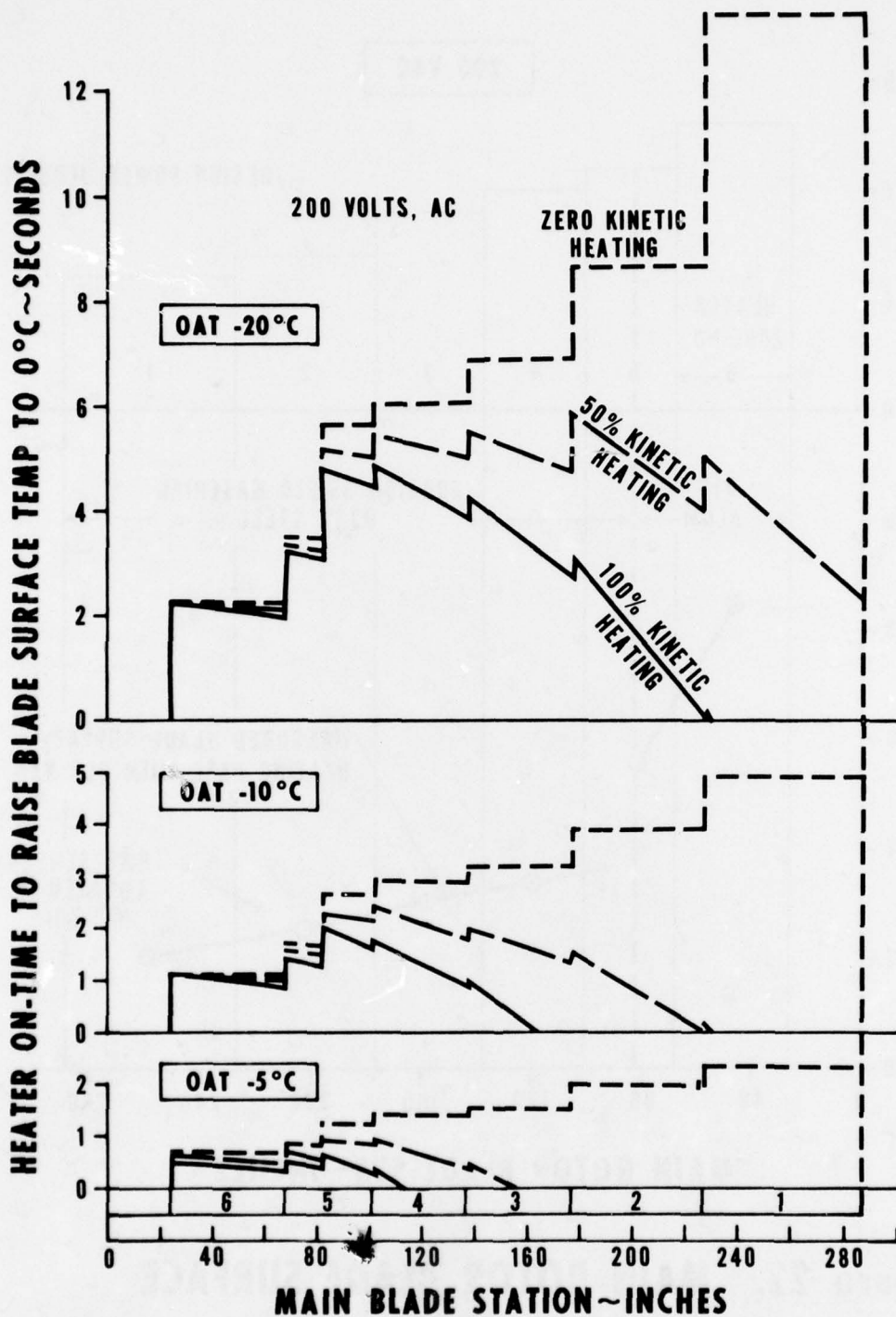

Figure 23. EFFECT OF KINETIC HEATING AND OAT ON HEATER-ON TIME VS BLADE SPAN

200V

BLADE DEICE CYCLE IN NATURAL ICING CLOUD OF 0.1 g/m³ LWC
OAT - 12.5°C

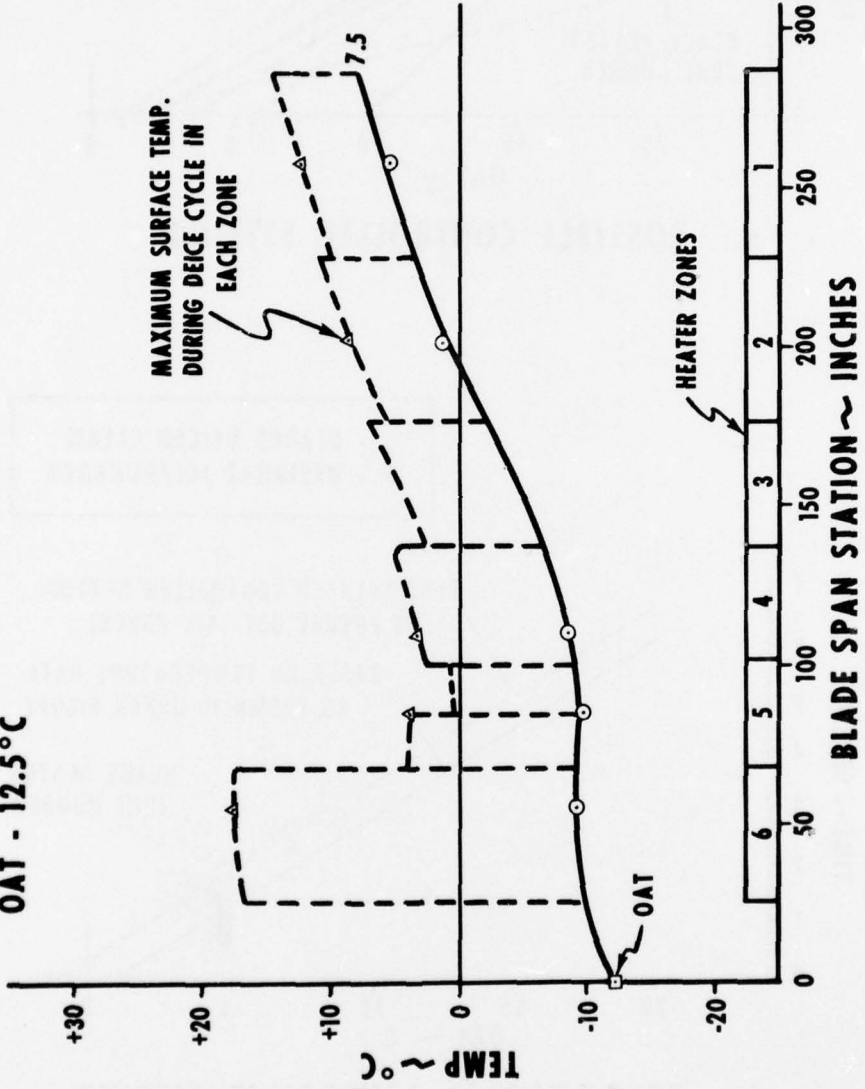
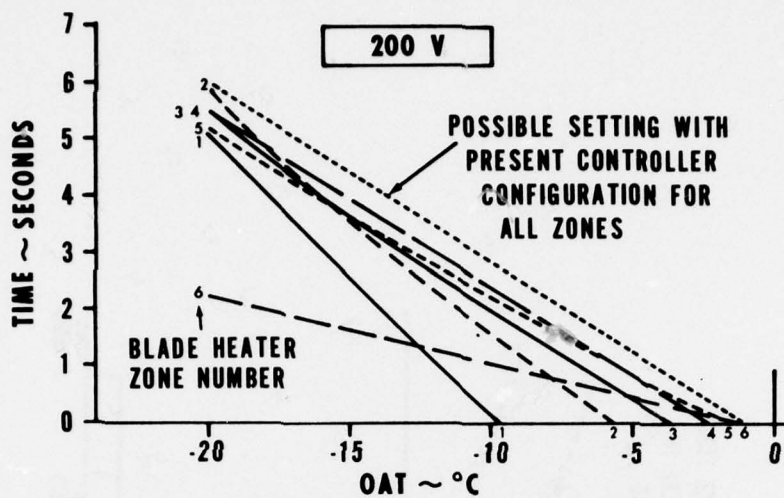
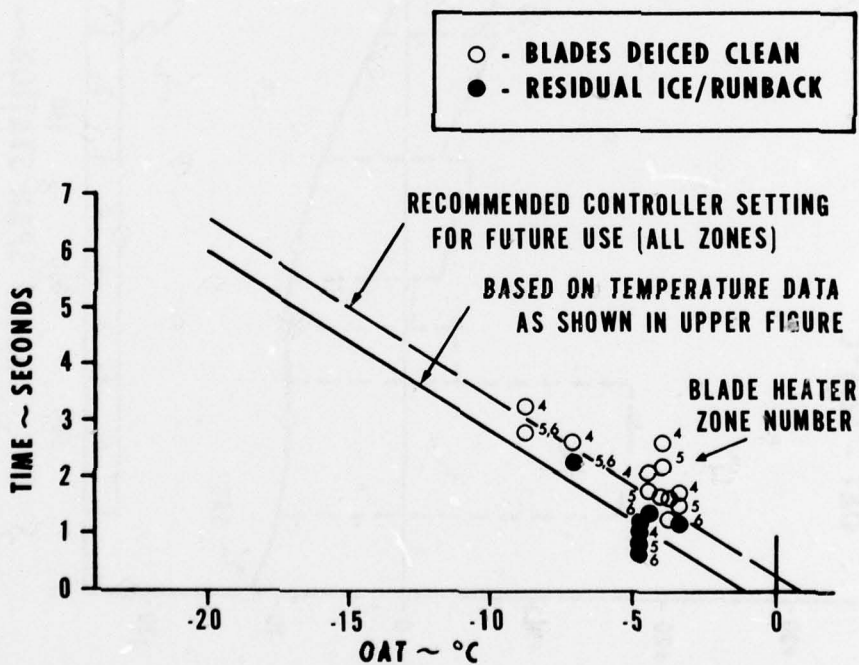

Figure 24. MAIN BLADE SURFACE TEMPERATURE DURING BLADE DEICE CYCLE ON A NATURAL ICING FLIGHT



a. POSSIBLE CONTROLLER SETTING



b. RECOMMENDED CONTROLLER SETTING

Figure 25. MAIN ROTOR BLADE HEATER ON-TIME vs OAT

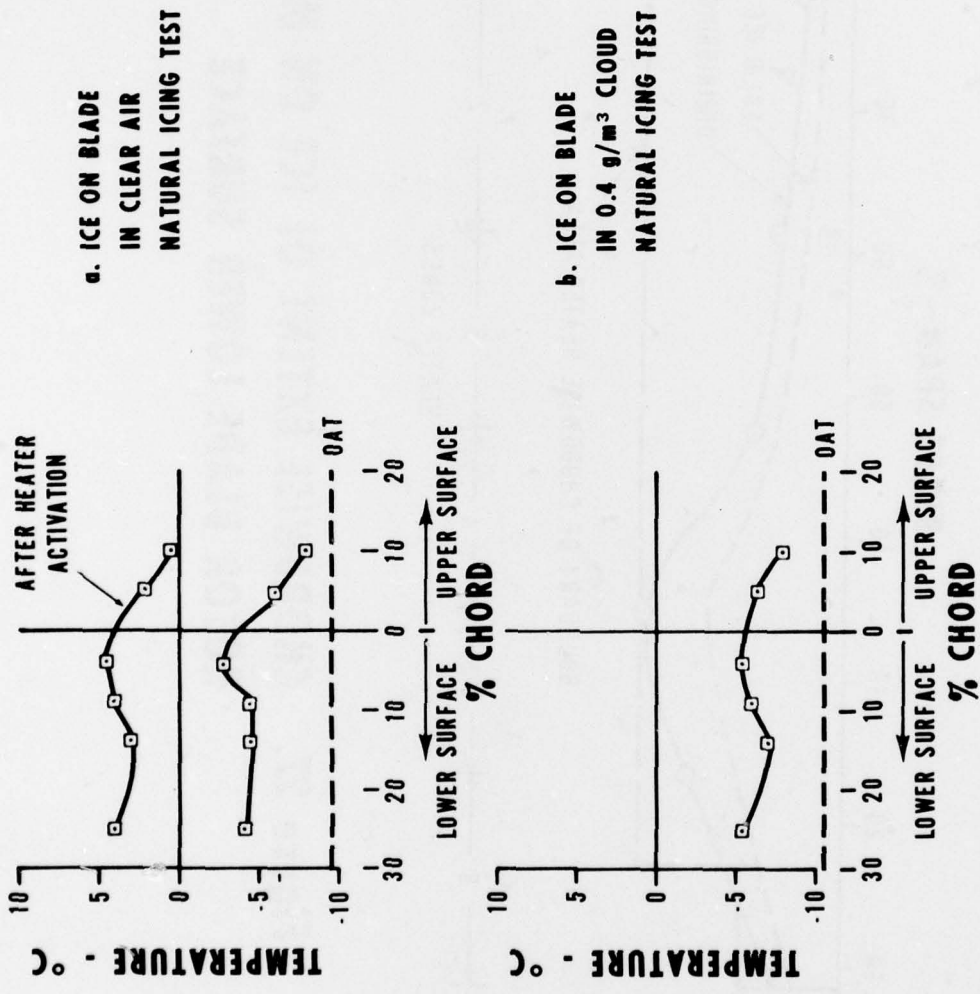

BASED ON SPRAY RIG TESTS
 -8.5 ≤ OAT ≤ -20°C

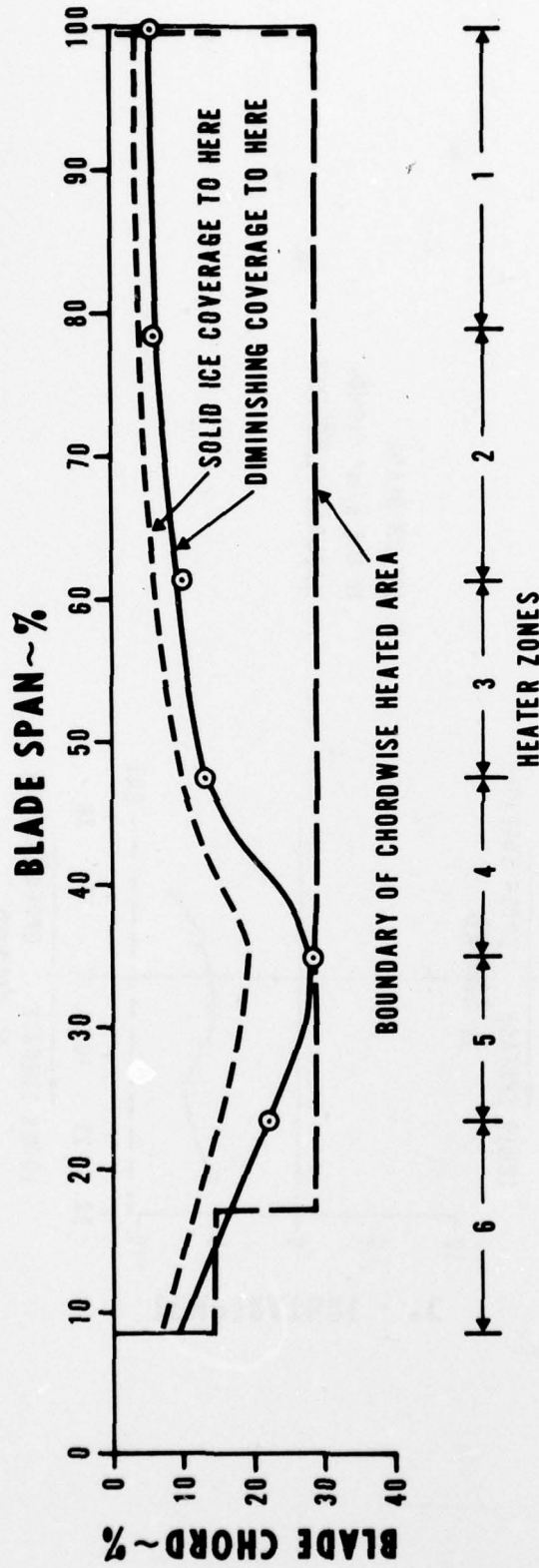
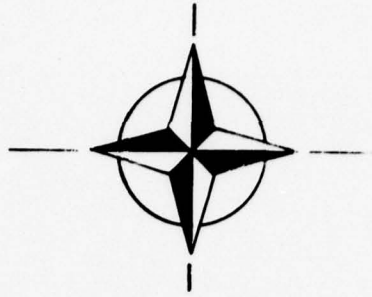

Figure 27. CHORDWISE EXTENT OF ICE ON MAIN ROTOR BLADE LOWER SURFACE



NATO ARMY ARMAMENT GROUP

**PROTECTION SYSTEMS AGAINST ICING
ON THE PUMA**

BY
J.C. LECOUTRE

AEROSPATIALE, HELICOPTER DIVISION,
MARIGNANE, FRANCE

**SYMPOSIUM ON
HELICOPTER ICING**

**6-7 November 1978
LONDON**

PROTECTION SYSTEMS AGAINST ICING ON THE "PUMA"

1. INTRODUCTION

The helicopter operating envelope being in constant expansion, the trend among the constructors is to produce truly "all weather" aircraft meeting the requirements of both civil and military customers.

In particular, flight in icing conditions, prohibited to-day to most helicopters, requires very specific equipment.

There are two possible approaches to the problem :

The first consists in providing the helicopter with a minimum of protection on engine air intakes and windshield only and thus allow flight in icing conditions within a limited altitude and temperature envelope and this in icing severities qualified as "light".

In the second, the helicopter is fitted with several high performance protection systems allowing flight in icing conditions, without any limitation, over the whole altitude and temperature envelope in extremely severe icing conditions.

Although the severity notion is not the subject of accepted criteria, it is worthwhile to recall the definitions most often quoted :

Ice traces : 1/2 inch of ice accumulating on a fixed probe every 80 miles.

Light icing : 1/2 inch of ice accumulating on a fixed probe every 40 miles.

Moderate icing : 1/2 inch of ice accumulating on a fixed probe every 20 miles.

Severe icing : 1/2 inch of ice accumulating on a fixed probe every 10 miles.

The greatest critic relative to this criterion concerns the in-flight determination of the liquid water contents, which is the parameter governing the severity.

The direct reading of ice thickness on a fixed probe, beside the poor accuracy of the method, gives a post-idea of the severity and the crew is faced with the "fact", after some time has elapsed.

To-date, it seems that there is no instrument capable of making in flight, on helicopters, a sufficiently accurate determination of this parameter.

In the study made by Lockheed-California on behalf of the U.S. Army, the four severity levels have been assessed with respect to the characteristic curves given in FAR 25, appendix C. (figure 1).

On the curves, it can be noted, on the one hand, the presence of moderate icing in stratiform type clouds at temperatures ranging from 0 to -10° C, and, on the other hand, that light icing concerns only a very small part of the envelope related to cumuliform type clouds. (figure 2).

All these considerations have led Aerospatiale, to provide the PUMA with a sophisticated protection system authorizing flight in icing conditions, without any limitation but with a maximum of safety.

2. DESCRIPTION OF "PUMA" PROTECTION SYSTEMS (figure 3)

The SA 330 "PUMA", certified for flight in icing conditions, is provided with all the following protection systems :

- a) Composite main rotor blades with electric de-icing system
- b) Metal tail rotor blades with electric anti-icing system
- c) Control, monitoring and power distribution electronics for the main and tail rotor blades
- d) Slip-rings for power distribution to main and tail rotor blades
- e) Windshield with electric anti-icing system
- f) Pitot heads with electric anti-icing system
- g) Multi-purpose engine air intakes
- h) Weather radar
- i) Fuel system protected against lightning strikes
- j) Various fairings

2.1 Main rotor blades (figure 4)

The composite main rotor blades are electrically de-iced through 5 heating resistors embedded in an elastomer material bonded on the leading edge (DUNLOP-PAULSTRA) the whole being covered by a titanium anti-erosion protective strip.

Chordwise, the area protected extends over 20 % on lower surface and 7% on upper surface. Spanwise, this protection is provided from 17 to 99 %, and the unit power is as follow :

from 17 to 62 % - 3.2 W/sq.cm

from 62 to 77 % - 2.7 W/sq.cm

from 77 to 99 % - 2.3 W/sq.cm

The three-phase 115/200 volt power is applied successively to the five heating strips, by pairs of opposite blades for 10 or 16 seconds according to outside air temperature.

It is to be noted that these blades are protected against the catastrophic effects of lightning and hail. (figure 5).

2.2. Tail rotor blades (figure 6)

The metal tail rotor blades are electrically anti-iced through 3 heating resistances embedded in an elastomer material bonded directly onto the leading edge.

Chordwise, the area protected extends over 15 %

Spanwise, this protection is provided from 32 to 100 % and the unit power is as follow :

from 32 to 54 % : 1.7 W/sq.cm for the leading edge strip
1.23 W/sq.cm for the 2 other strips

from 54 to 69.5 % : 2 W/sq.cm for the leading edge strip
1.5 W/sq.cm for the 2 other strips

from 69.5 to 100 % : 2.5 W/sq.cm for the leading edge strip
1.95 W/sq.cm for the 2 other strips.

The three-phase 115/200 volt power is applied continuously to the three strips of the 5 blades.

These blades are protected also against the effects of lightning and hail (figure 7).

2.3. Control, monitoring and power distribution electronics (manufactured by E.C.E.)

This electronic system, fully duplicated to ensure redundancy, consists mainly of :

- a distribution section, located on the rotor head (figure 8)
- a set of power supply and monitoring "black boxes", located in the cabin
- a control box, located overhead in the cockpit (figure 9).

In addition to the normal controls, that is :

- Switching on of power supply to main and tail rotor blades
- Selection of either one of the two sub-assemblies
- Selection of temperature,

this control box includes :

- A severe icing function allowing ice shedding over 3 cycles maximum in particularly critical cases.
- A set of warning lights and a test function, usable on the ground and in flight.

It is to be noted that this electronic system is protected against atmospheric overvoltages.

2.4. Power distribution slip-rings (manufactured by AIR PRECISION)

The slip rings ensuring the electric power supply to the main rotor blades are located on the rotor head within the distribution box. The power supply to the tail rotor blades is ensured through a slip-ring secured on the tail gear box (figure 10).

For both slip-rings, which are permanently in contact, the T.B.O. is 3000 hours.

2.5. Windshield

The pilot's, copilot's and centre windshield are provided with an electric heating mat interposed between two semi-toughened panes, 3.2 mm. thick.

These windshields are designed to withstand the impact of hail.

2.6. Pitot heads (figure 11)

They are designed for flight in continuous icing and provided with an electric anti-icing system.

2.7. Multi-purpose engine air intakes (figure 12)

Protection is ensured by a bullet blanking off the ram air inlet. In this case, engine air supply is ensured through several vortex tubes normal to the general flow.

These vortex tubes provide an efficient protection against icing and snow.

2.8. Weather radar (figure 13)

The cumulo-nimbus type of clouds, with large vertical motion, are avoided, to the maximum, thanks to a weather radar installed in the aircraft nose.

2.9. Fuel system lightning protection

To take into account the weather phenomena likely to be met at a higher frequency in this particular type of mission, it has been necessary to consider lightning strike and minimize its disastrous effect, particularly on the fuel system.

Several modifications have been brought to the basic aircraft :

- replacement of inspection doors made of laminates by metal panels
- efficient ventilation of fuel tank bays
- flame traps on fuel tank vents.

2.10. Various fairings

Several fairings, specific for flight in icing conditions, have been installed on the aircraft.

- Rear servo unit fairing (figure 14)
- Main blade droop restrainer fairing (figure 15)
- Anti-wake fairing on rotor head distribution box (figure 16).

3. SUBSTANTIATION TESTS

In spite of the experience acquired, as early as 1964, with prototype installations fitted to ALOUETTE III and SUPER-FRELON helicopters, many ground and flight tests, spread over 4 years, have been necessary for the development of the PUMA icing protection systems.

3.1. Ground tests :

Among the most significant, let us mention :

- a) the tests on the multi-purpose air intake at the "Centre d'essais des Propulseurs" in Saclay (figure 17).

Through a very exhaustive test programme, it has been possible to check the efficiency of this type of protection according to various parameters :

- Temperature
- Water contents
- Altitude
- Helicopter speed
- Engine r.p.m.

- b) Lightning tests

The purpose of these tests was to check, on the one hand, the structural strength of main and tail rotor blades in case of a real lightning strike, and, on the other hand, the non-sensitivity of electronics to atmospheric overvoltages.

- c) Hail resistance tests

These tests, run at the Centre d'essais des Propulseurs in Saclay, have allowed to check, at the helicopter maximum speed, the resistance to 1 inch diameter hail stones of various components the damage of which could lead to disaster :

- main rotor blade
- tail rotor blade
- lead-lag damper oil reservoir
- windshield
- engine air intake.

- d) Fatigue tests on heating mats (figure 18)

The excellent fatigue strength of the heating mats fitted onto the composite blades has been demonstrated by these tests.

3.2. Flight tests

Three successive campaigns have been necessary for the final development of the protection systems.

Winter 1975/76 : in Canada, in front of the NRC icing grid in OTTAWA (figure 19).

This campaign has allowed the optimization of heating unit powers for the main blades in view of avoiding re-freezing problems.

Winter 1976/77 : Campaign in natural icing, in France.

The "off-time" between the various heating sequences on the main rotor determined during the previous trials had to be optimized for forward flight.

During these tests, two successive failures in the cycling electronics have shown that it was necessary to protect the installation against atmospheric overvoltages.

Winter 1977/78 : Campaign in natural icing, in Denmark.

The purpose of these tests was, on the one hand, to check the reliability of the control electronic system protected against overvoltages, and, on the other hand, optimize the main rotor heating sequences for temperatures lower than -10° C.

In fact, at this temperature and below, it is necessary in every cycle to energize twice the leading edge strip, in particular to reduce engine torque.

At the total, more than 300 hours have been flown in very different icing conditions.
(figure 20).

CONCLUSIONS :

At the end of the last campaign in natural icing, the SA 330 "PUMA" helicopter has been granted its Certificate of Airworthiness for flight in icing conditions without any limitation, by the relevant French Authorities on April 25th, 1978.

Thus, the "PUMA" becomes the first truly "all-weather" helicopter in the Western World.

REFERENCES :

- Helicopter icing handling qualities - Lt. Col. Warren E. Griffith
Cpt. Larry K. Brewer
- The development of an advanced anti-icing/de-icing capability for U.S. Army helicopter - J.B. Werner.

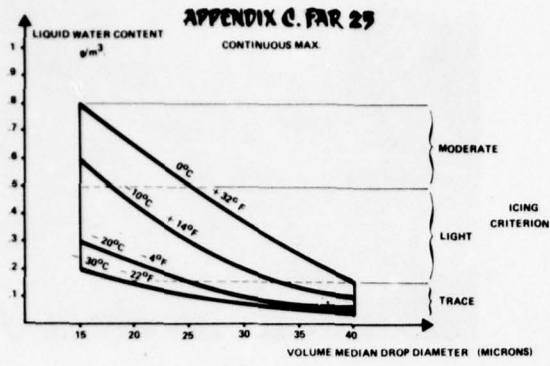

FIGURE 1 - F.A.R. 25 - CONTINUOUS MAX.

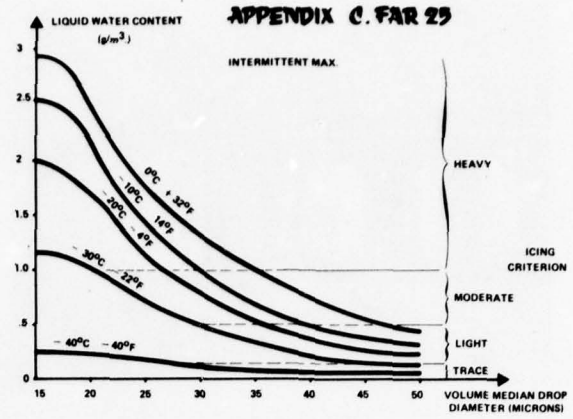

FIGURE 2 - F.A.R. 25 - INTERMITTENT MAX.



FIGURE 3 - GENERAL VIEW OF AIRCRAFT

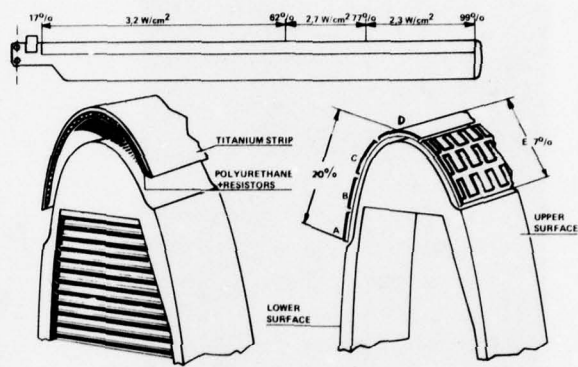

FIGURE 4 - SA.330 DE-ICED MAIN BLADE

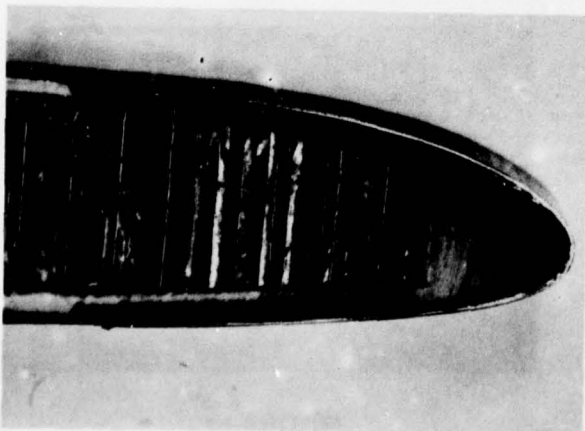

FIGURE 5 - SA.330 DE-ICED MAIN BLADE

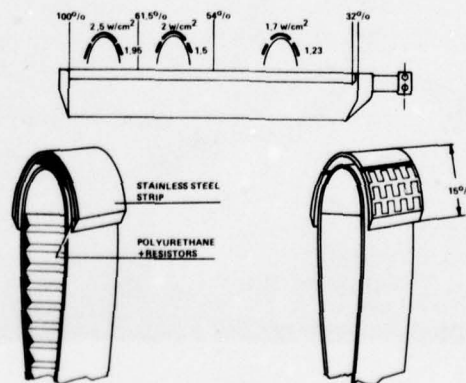

FIGURE 6 -
SA.330 DE-ICED TAIL ROTOR BLADE

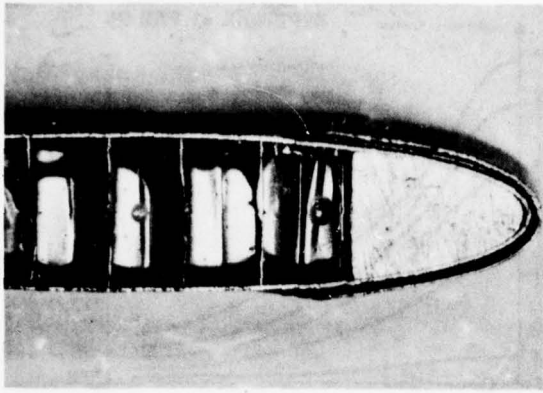

FIGURE 7
SA.330 DE-ICED TAIL ROTOR BLADE

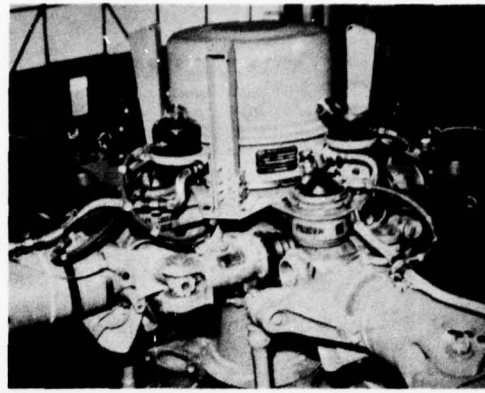

FIGURE 8
DISTRIBUTOR ON ROTOR HEAD

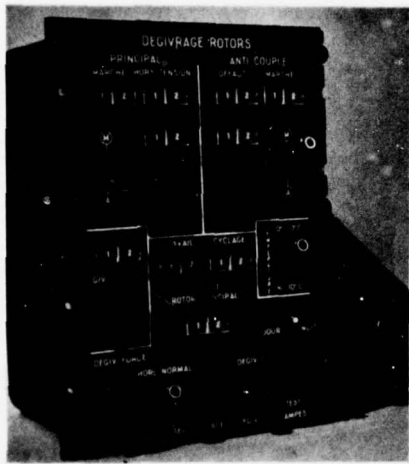

FIGURE 9 - CONTROL BOX

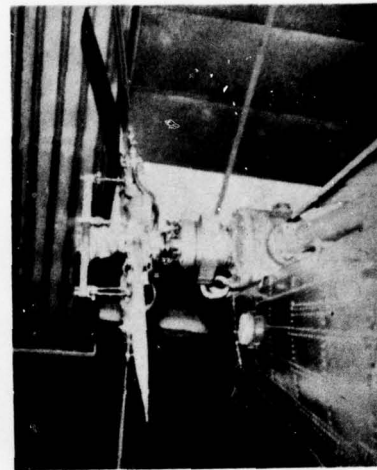

FIGURE 10
TAIL ROTOR SLIP RING

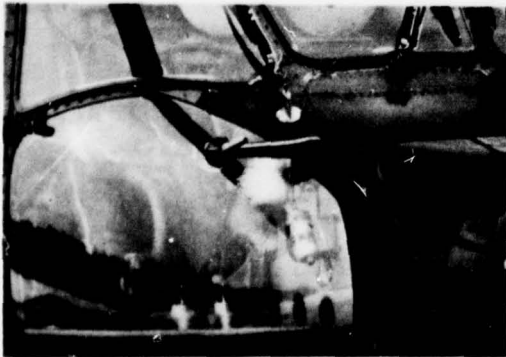

FIGURE 11 - ANTI-ICED PITOT HEAD

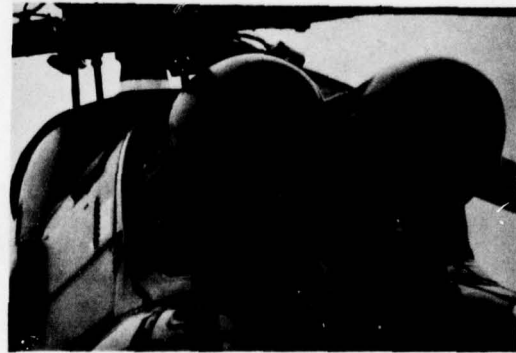

FIGURE 12
MULTI-PURPOSE ENGINE AIR INTAKE



FIGURE 13 - WEATHER RADAR

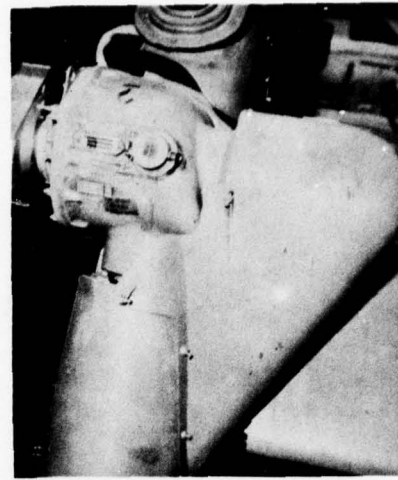

FIGURE 14

TAIL ROTOR SERVO-UNIT FAIRING



FIGURE 15

BLADE DROOP RESTRAINER

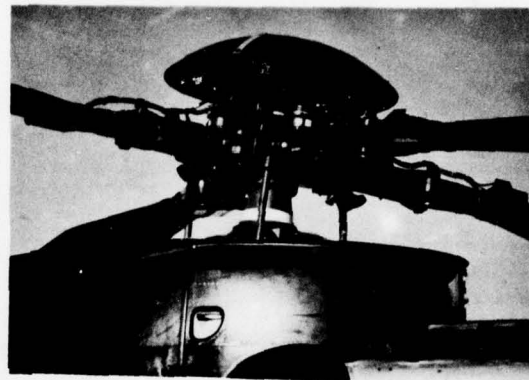

FIGURE 16

MAIN ROTOR HEAD FAIRING

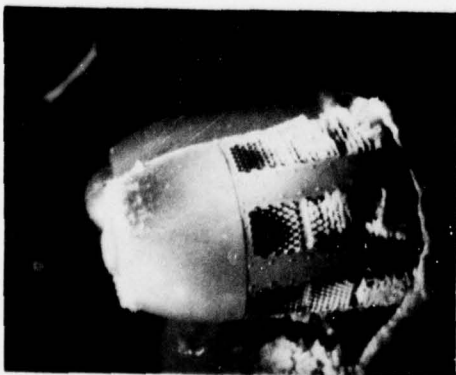

FIGURE 17

TESTING OF MULTI
PURPOSE AIR INTAKE

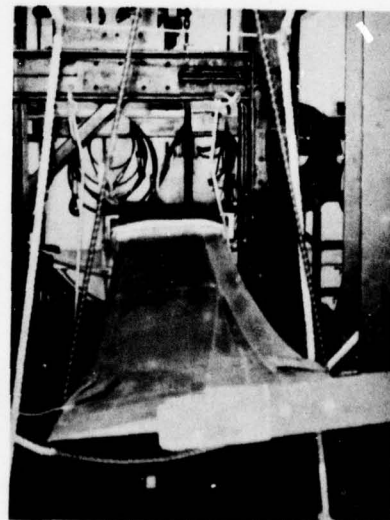

FIGURE 18 - FATIGUE TESTING
OF DE-ICED MAIN BLADE

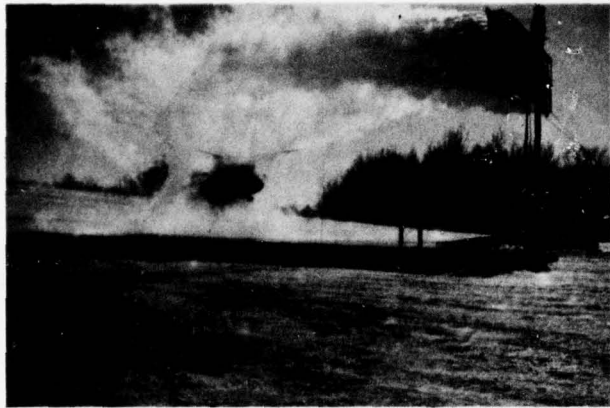

FIGURE 19 - ARTIFICIAL ICING TEST IN CANADA

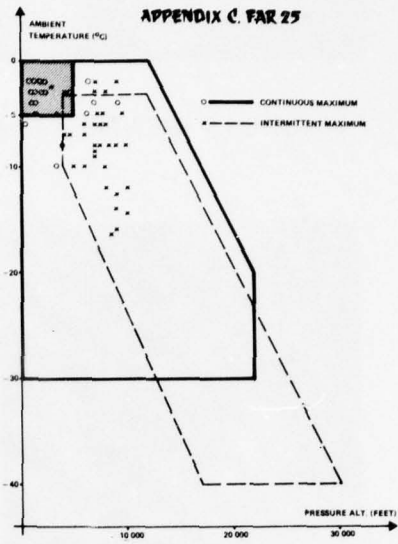

FIGURE 20 - F.A.R. 25 - APPENDIX "C"

SYSTEME DE PROTECTION CONTRE LE GIVRE DU SA 330 PUMA

1. INTRODUCTION

Le domaine d'utilisation des hélicoptères s'étendant sans cesse, les constructeurs tendent à faire de leurs machines de véritables appareils "tout temps", à la demande aussi bien des clients civils que militaires.

Le vol en conditions givrantes, en particulier, aujourd'hui interdit pour la plupart des hélicoptères, nécessite des équipements très spécifiques.

Deux approches du problème sont possibles :

La première consiste à équiper l'hélicoptère d'un minimum de protection, sur entrées d'air moteur et glaces du poste de pilotage uniquement, et permettre ainsi le vol en conditions givrantes dans un domaine altitude, température restreint, et cela avec des sévérités de givrage qualifiées de légères.

La seconde consiste à équiper l'hélicoptère de protections multiples très performantes, autorisant le vol en conditions givrantes, sans limitations, dans l'ensemble du domaine altitude, température avec des sévérités de givrage extrêmes.

Bien que les notions de sévérité ne fassent pas l'objet de critères reconnus, il est bon de rappeler les définitions les plus souvent mentionnées :

- traces de givre : accumulation d'un 1/2 inch. de glace sur un témoin fixe tous les 80 miles,
- givrage léger : accumulation d'un 1/2 inch. de glace sur un témoin fixe tous les 40 miles,
- givrage modéré : accumulation d'un 1/2 inch. de glace sur un témoin fixe tous les 20 miles,
- givrage sévère : accumulation d'un 1/2 inch. de glace sur un témoin fixe tous les 10 miles.

La plus grande critique concernant ce critère réside dans la mesure en vol de la concentration en eau liquide, paramètre déterminant de la sévérité.

La lecture directe de l'épaisseur de glace sur un témoin fixe, outre le peu de précision de la méthode, donne une notion à posteriori de la sévérité et met l'équipage devant le "fait accompli" au bout d'un certain laps de temps.

Il n'existe pas semble-t-il, à l'heure actuelle, d'instrumentation capable d'effectuer en vol sur hélicoptère une mesure ponctuelle suffisamment précise de ce paramètre.

Dans l'étude faite par la Compagnie Lockheed-California pour le compte de l'armée américaine, les 4 degrés de sévérité ont été estimés par rapport aux courbes caractéristiques de la FAR 25, App. C.

On constate sur ces courbes, d'une part la présence de givrage modéré dans les nuages de type stratiforme entre 0 et -10°C , d'autre part que le givrage léger n'intéresse qu'une très faible partie du domaine relatif aux nuages de type cumuliforme (Figure 1).

Toutes ces considérations ont conduit l'Aérospatiale, en premier lieu, à équiper le Puma d'un système de protection sophistiqué, autorisant le vol en conditions givrantes sans limitations, avec le maximum de sécurité. (Figure 2)

2. DESCRIPTION DES SYSTEMES DE PROTECTION DU PUMA (Figure 3)

Le PUMA SA 330, avec mention givrage, est équipé de l'ensemble des protections suivantes :

- a) - Pales principales plastiques dégivrées électriquement.
- b) - Pales arrières métalliques antigivrées électriquement.
- c) - Electronique de commande, contrôle et distribution aux pales principales et arrières.
- d) - Collecteurs de distribution aux pales principales et arrières.
- e) - Glaces du poste de pilotage antigivrées électriquement.
- f) - Prises de pression totale antigivrées électriquement.
- g) - Entrées d'air moteur polyvalentes.
- h) - Radar météorologique.
- i) - Circuit carburant antifoudre.
- j) - Carénages divers.

2.1. PALES PRINCIPALES (Figure 4)

Les pales principales plastiques sont dégivrées électriquement au moyen de 5 résistances chauffantes noyées dans un élastomère collé sur le bord d'attaque (Dunlop-Paulstra). L'ensemble est recouvert d'une protection titane anti-érosion.

En corde, la zone protégée est de $20^{\circ}/\text{o}$ à l'intrados et de $7^{\circ}/\text{o}$ à l'extrados. En envergure, cette protection s'étend de 17 à $99^{\circ}/\text{o}$ avec les puissances unitaires suivantes :

| | |
|---------------------------------|------------------------|
| de 17 à $62^{\circ}/\text{o}$ | $3,2 \text{ W/cm}^2$. |
| de 62 à $77^{\circ}/\text{o}$ | $2,7 \text{ W/cm}^2$. |
| de 77 à $99^{\circ}/\text{o}$ | $2,3 \text{ W/cm}^2$. |

Les cinq bandes chauffantes sont alimentées successivement en triphasé $115/200 \text{ V}$ par paire de pales opposées pendant 10 ou 16 secondes suivant la température extérieure. A noter que ces pales sont protégées contre les effets catastrophiques de la foudre et de la grêle (Figure 5).

2.2. PALES ARRIERES (Figure 6)

Les pales arrières métalliques sont antigivrées électriquement au moyen de 3 résistances chauffantes noyées dans un élastomère collé en surépaisseur sur le bord d'attaque. L'ensemble est recouvert d'une protection acier inoxydable anti-érosion.

En corde, la zone protégée est de $15^{\circ}/\text{o}$.

En envergure, cette protection s'étend de 32 à 100 °/o avec les puissances unitaires suivantes

| | |
|-------------------------------|---|
| de 32 à 54 ⁰ /o | 1,7 W/cm ² pour la bande de bord d'attaque 1,23 W/cm ² pour les deux autres bandes |
| de 54 à 69,5 ⁰ /o | 2 W/cm ² pour la bande de bord d'attaque 1,5 W/cm ² pour les deux autres bandes |
| de 69,5 à 100 ⁰ /o | 2,5 W/cm ² pour la bande de bord d'attaque 1,95 W/cm ² pour les deux autres bandes |

Les trois bandes de chacune des cinq pales sont alimentées sans interruption en triphasé 115/200 Volts.

Ces pales sont également protégées contre les effets catastrophiques de la foudre et de la grêle. (Figure 7).

2.3. ELECTRONIQUE DE COMMANDE, CONTROLE ET DISTRIBUTION

Cette électronique, de fabrication E.C.E et entièrement doublée pour assurer une redondance du système, se compose essentiellement :

- d'une partie distribution située sur la tête rotor (Figure 8),
- d'un ensemble de "boîtes noires" d'alimentation et de contrôle situé en soute,
- d'une boîte de commande située au plafond du poste de pilotage (Figure 9),

En plus des commandes normales, à savoir :

- enclenchement alimentation pales principales et arrières
- choix de l'un ou l'autre des deux sous-ensembles
- sélection température

Cette boîte de commande regroupe :

- une fonction givrage sévère permettant en 3 cycles maximum l'évacuation de givre dans les cas particulièrement critiques,
- un ensemble de voyants défauts et une fonction test pouvant être actionnée au sol ou en vol.

A noter que l'ensemble de l'électronique est protégé contre les surtensions électriques atmosphériques.

2.4. COLLECTEURS DE DISTRIBUTION (Fabrication Air-Precision)

Le collecteur permettant l'alimentation électrique aux pales principales est situé sur la tête rotor à l'intérieur du boîtier de distribution. L'alimentation aux pales arrières s'effectue grâce à un collecteur fixé sur la boîte de transmission arrière (Figure 10).

Le potentiel de ces deux collecteurs, en contact permanent, est de 3 000 heures.

2.5. GLACES DU POSTE DE PILOTAGE (Figure 11)

Les glaces pilote, co-pilote et centrales sont équipées d'un tapis chauffant électrique enserré entre deux feuilles de glace semi-trempées de 3,2 mm. d'épaisseur.

Ces glaces sont étudiées pour résister à l'impact de la grêle.

2.6. PRISES DE PRESSION TOTALE

Ces sondes, spécialement étudiées pour le vol en givrage continu, sont munies d'un anti-givrage électrique.

2.7. ENTREES D'AIR MOTEUR POLYVALENTES (Figure 12)

La protection est assurée par une ogive qui vient obturer l'entrée d'air dynamique. Dans ce cas, l'air est aspiré par de multiples Vortex perpendiculaires à l'écoulement général.

Ces vortex assurent une protection efficace contre le givre et la neige.

2.8. RADAR METEOROLOGIQUE (Figure 13)

Les nuages de type cumulo-nimbus, à fort déplacement vertical, sont évités, au maximum, grâce à un radar météorologique monté sur le "nez" de l'appareil.

2.9. CIRCUIT CARBURANT ANTIFOUDRE

Pour tenir compte de phénomènes météorologiques risquant d'être rencontrés à plus grande fréquence dans ce type particulier de mission, il a été nécessaire de tenir compte du foudroiement et de minimiser son aspect catastrophique, notamment sur le circuit de carburant.

Plusieurs modifications ont été apportées à l'appareil de base :

- remplacement des portes de visite en stratifié par des portes métalliques,
- ventilation efficace dans les compartiments réservoirs,
- barrières anti-feu dans les mises à l'air libre des réservoirs.

2.10. CARENAGES DIVERS

Plusieurs carénages spécifiques du vol en conditions givrantes sont montés sur l'appareil :

- carénage de servo-commande arrière (Figure 14),
- carénage de butée de pale principale (Figure 15),
- carénage antisillage de boîtier de distribution sur tête rotor (Figure 16).

3. ESSAIS JUSTIFICATIFS

Malgré l'expérience acquise dès 1964 sur des installations prototypes montées sur hélicoptères ALOUETTE III et SUPER-FRELON, un grand nombre d'essais au sol et en vol, échelonnés sur quatre années, ont été nécessaires à la mise au point des systèmes de protection du PUMA contre le givre.

3.1. ESSAIS SOL

Parmi les plus significatifs, citons :

- a) - Les essais d'entrée d'air polyvalente au Centre d'Essais des Propulseurs de Saclay (Fig.17)

Un programme d'essais très complet a permis de vérifier l'efficacité au givre de ce type de protection en fonction de différents paramètres :

Température,
Concentration en eau,
Altitude,
Vitesse hélicoptère,
Régime turbine.

b) - Essais de foudroiement

Ces essais ont permis de vérifier d'une part la tenue structurale des pales principales et arrières lors d'un foudroiement effectif, et d'autre part l'insensibilité de l'électronique aux surtensions électriques atmosphériques.

c) - Essais de tenue à la grêle

Ces essais, effectués au Centre des Propulseurs de Saclay, ont permis de vérifier, à la vitesse maximale de l'hélicoptère, la tenue aux grêlons de 1 pouce de divers éléments dont la détérioration serait susceptible d'être catastrophique :

- pale principale,
- pale arrière,
- bol d'huile d'alimentation des amortisseurs de traînée,
- glace du poste de pilotage,
- entrée d'air moteur

d) - Essais de fatigue des tapis chauffants (Figure 18)

Ces essais ont permis de vérifier l'excellente tenue en fatigue des tapis chauffants équipant les pales plastiques.

3.2. ESSAIS EN VOL

Trois campagnes successives ont été nécessaires pour la mise au point définitive des systèmes de protection.

Hiver 1975/76 : Campagne Canada devant la grille du
NRC à Ottawa (Figure 19)

Cette campagne a permis l'optimisation des puissances unitaires de chauffage des pales principales de façon à éviter les problèmes de regel. Hiver 1976/77. Campagne en givrage naturel en France.

Les temps de repos entre les différentes séquences de chauffe du rotor principal, déterminées lors de la précédente campagne, ont dû être optimisés en vol d'avancement.

Au cours de ces essais, deux pannes successives de l'électronique de cyclage ont mis en évidence la nécessité de protéger l'installation contre les surtensions électriques atmosphériques.

Hiver 1977/78. Campagne en givrage naturel au Danemark.

Ces essais ont permis d'une part de vérifier la fiabilité du système électronique de commande protégé contre les surtensions électriques, d'autre part d'optimiser les séquences de chauffage du rotor principal pour les températures inférieures à -10°C .

En effet, à partir de cette température, il est nécessaire dans un cycle d'alimenter 2 fois la bande de bord d'attaque pour diminuer notamment le couple moteur.

Au total, plus de 300 heures de vol ont été effectuées avec des conditions de givrage très diverses (Figure 20).

CONCLUSION

A l'issue de la dernière campagne en givrage naturel, l'hélicoptère SA 330 PUMA a reçu des services officiels français, le 25 avril 1978, son certificat de navigabilité pour le vol en conditions givrantes sans aucune limitation.

Le PUMA est ainsi devenu le premier hélicoptère véritablement "Tout temps" du monde occidental.

REFERENCES

HELICOPTER ICING HANDLING QUALITIES by Ltc. Warren E. Griffith &
Cpt. Larry K. Brewer.

THE DEVELOPMENT OF AN ADVANCED ANTI-ICING/ DE-ICING CAPABILITY
FOR U.S.ARMY HELICOPTERS by J.B. Werner.

U.K. ROTOR BLADE ICE PROTECTION PROGRAMME

A REVIEW OF PROGRESS

by

D. R. SHEPHERD

WESTLAND HELICOPTERS LIMITED

Paper for Presentation at NATO Panel X Helicopter

Icing Symposium, London 6-7 November 1978

Abstract : Progress of the UK programme of in-flight investigation, in natural icing conditions, of the characteristics of rotor blade cyclic ice removal systems, is described and interpreted in the context of the requirements for fully certificated service systems conferring icing flight airworthiness over the operationally and meteorologically relevant range of natural icing conditions.

From a consideration of the basic characteristics of cyclic ice removal systems, as originally conceived, and the relationships between the required helicopter operating envelope, the statistical icing probabilities and the influences of icing temperature and severity on the level of rotor aerodynamic degradation experienced, and which can be tolerated, during flight in icing conditions, potentially critical cyclic ice-removal performance criteria are identified.

Possible modifications to the cycle parameters, to meet critical operating requirements and overcome limitations inherent in current systems, are discussed.

1. INTRODUCTION :

Although some icing work based on the Bristol Sycamore helicopter was carried out as early as 1952 (Ref.1), the origins of the current U.K. helicopter rotor blade ice protection programme can be traced to the experimental testing of a Wessex Mk.1 helicopter, equipped with a Napier rotor blade de-icing system, in the NRC Spray Rig in Canada, in 1961.

For these trials, the ice protection system received power from a ground generator system and testing was therefore restricted to hovering flight in the Spray Rig, no evaluation of system characteristics in forward flight and natural icing conditions being possible with this arrangement.

The system design philosophy and test procedure was based substantially on the principles in general use at that time and developed initially at the National Research Council (Ref.1). This test approach aimed specifically at the investigation of cyclic de-icing power density requirements and the definition and optimisation of the heater 'ON' and 'OFF' times required to give efficient ice shedding performance.

Although the results of this work were very encouraging (Ref.2), there was a lapse in this activity in the UK for several years pending identification of an operational requirement which would warrant the expense and complexity of engineering development and flight trials programme which would be involved.

However, in 1968, following the development and introduction into service of the ASW Wessex helicopter and, subsequently, the Sea King, with their greatly improved I.F.R. capability and, concurrently, the increased civil all-weather operations in support of North Sea oil exploration, there was a renewal of interest in helicopter icing flight in Britain.

The resulting development and flight trials programmes have involved three main areas of activity:

- (i) Development of ice and snow protection for helicopter engines
- (ii) Investigation of the flight potential of unprotected helicopter rotor systems in Natural Icing Conditions
- (iii) Investigation of the performance characteristics and operating criteria for electro-thermal cyclic de-icing of rotor blades in Natural Icing Conditions.

The purpose of this paper is to review the progress of the rotor blade ice protection programme to date. However, it should be noted that, although topics (i) and (ii) fall outside the primary scope of this discussion, the concurrent activity on engine protection and unprotected rotor systems has contributed substantially to the progress and achievements of the rotor blade ice protection programme. In particular, whereas fifteen years ago there was very little flight experience of helicopter characteristics in natural icing conditions and system design had, of necessity, to be based on theory and the results of Rig tests, we now have a very substantial background of

knowledge and experience upon which to draw when planning, conducting and interpreting rotor blade ice protection systems trials. Related trials have also contributed to the development of important trials techniques and test equipment (Ref.3, 4). But, above all, there is now a much wider appreciation and acceptance of the rotor system protection standards which must be met to support icing flight airworthiness and provide helicopters with a viable, all-weather, flight capability over the operationally relevant range of natural icing environments.

Trials work carried out with the present Wessex helicopter equipped with a heat rotor blade development system is summarised in Table 1. Four trials periods, two in Canada, and two in Denmark have produced 10 hours of Icing Rig Flying and nearly 40 hours in natural icing conditions. Flights have been of varying duration depending on the icing conditions and the specific test requirements. On many occasions the natural icing conditions encountered were identified as severe, approaching Design Standard Maximum Continuous conditions, and the potential rotor performance degradation levels, inferred from this flying, such that continued flight in the environment would not have been possible without rotor blade protection. In addition to the flying carried out with the Heated Rotor blade trials helicopter, over 70 hours documented icing flying has been carried out with Wessex helicopters on other programmes without rotor blade protection.

These flying totals may not appear impressive in the context of eventual operational icing exposure. Nevertheless, they do represent a substantial increase in experience in relation to the current level of overall experience in this field.

As the programme has progressed, icing instrumentation and system performance diagnostic equipments have improved (Refs, 4,5); system trials techniques and test facilities have been extended; the range and severity of icing conditions actually encountered has expanded; and the theory and practice of cyclic de-icing is being refined and improved as the mechanism of the ice accretion and shedding processes and the protection requirements becomes better understood.

2. ROTOR BLADE ICE PROTECTION REQUIREMENTS :

Before reviewing the progress of the trials carried out to date, it is useful first to restate the fundamental performance requirements of a rotor ice protection system.

The objective of a rotor ice protection system is, first and foremost, to ensure a satisfactory level of airworthiness, - flight safety, structural and performance - over the range of flight and icing conditions which the helicopter is required, or is likely, to meet in operation.

Since the presence of varying amounts and shapes of ice on the leading edge and surfaces of rotor blades can radically alter the performance, control, and dynamic stress and aeroelastic stability characteristics of a rotor and blade system, icing flight substantiation for a helicopter implies, from a helicopter engineering standpoint, the flight testing and re-validation of the aircraft airworthiness for all relevant, potentially critical, combinations of aircraft speed, altitude, manoeuvre, atmospheric icing and periodically varying rotor ice accretion states which are likely to be experienced when flown within the stated limitations for the aircraft.

If an anti-icing system of rotor protection is in use, such that the rotor blades are to all intents and purposes free of ice in all conditions there is evidently no need for a re-validation of the rotor system in icing conditions. However, where a system of rotor blade cyclic de-icing is involved, the cyclic ice removal periodicity and the peak levels of rotor aerodynamic degradation which will occur within the ice removal cycle can have a major influence on the helicopter and rotor system characteristics experienced in flight. Helicopter performance, fatigue life and handling considerations therefore imply, for each set of circumstances, an upper limit of ice induced rotor aerodynamic degradation which can be tolerated. This, in turn, may impose constraints on the cyclic de-icing sequences and periodicity which will cope successfully with the various flight requirements. The design, development and certification of effective cyclic ice protection systems for helicopter rotors must therefore be approached as a major extension of basic helicopter flight airworthiness substantiation. In recognition of this, comprehensive strain gauging of major rotor and dynamic system components with supporting flight handling and performance instrumentation has been provided from the outset on the Wessex trials aircraft engaged on this programme.

During de-icing cycle development it is also most important that the ice removal processes can be studied, so far as practicable, so that the ice shedding characteristics can be critically interpreted in relation to the flight and atmospheric conditions involved and the cyclic sequences in use.

3. DESCRIPTION OF WESSEX HEATED ROTOR BLADE DEVELOPMENT SYSTEM

The electro-thermal heated rotor blade system which forms the basis of the present development programme was originally designed and produced in 1970/72, by Lucas Aerospace Limited (of which the former Napier Company now form a part) and Westland Aircraft Limited to meet a possible requirement for an operational protection system for the Westland Wessex helicopter.

The heater mat layout on the main rotor blades and the basic cycling sequence are shown in Figure 1. The total power requirements, initially 14.4 KVA, were increased to 15.9 KVA following minor revision and extension of heater layout and a small increase in power intensities after the first trial. Blade heater mats are of the spanwise type with power density varying in steps from around 30 watts/sq.in. at the blade root to about 20 watts/sq.in. at the outboard end of the blade.

The nominal design cyclic switching sequence consists of eleven segments arranged so that the three phase AC power load, supplied from an auxiliary generator drive from the main rotor transmission through an accessory gearbox, remains substantially balanced throughout the cycle.

In the interests of power economy, the main rotor blades are de-iced sequentially as two opposite pairs of blades, thereby retaining a measure of symmetry in the ice accretion and shedding pattern. Further segments are added to the cyclic programme to cater for the tail rotor (two tail rotor de-ice periods per cycle) and the cyclically heated areas of the horizontal stabiliser. A continuously heated leading edge 'breaker' strip is provided on the stabiliser.

The basic ice shedding sequence, leading edge aft, which has been in general use throughout the programme was also used during the earlier development activity, and appears to give satisfactory shedding behaviour. Aft forward and other variations of mat sequencing have been proposed from time to time but we have no knowledge of any test data identifying advantages or disadvantages of the different arrangements.

For a given heater mat distribution and cycling sequence, the operating characteristics of the system are fully defined by two parameters - the heater 'ON' time per segment and the cycle 'OFF' time.

The nominal design ON time relationship, shown in Figure 2, is a function of ambient temperature. Also shown in Figure 2 is the total cycle 'ON' time for eleven segments. For a given power intensity, the heat ON time determines the energy input per segment - this must be sufficient to melt the bond between the ice and the blade surface to enable the ice to be shed under the action of dynamic and aerodynamic loads. The heater ON times in general use now appear to be fairly well established and have been based partly on theoretical work and partly on the results of development experiments carried out in the NRC Spray Rig.

The heater OFF times are less easily defined and there is considerable scope for experimentation and adjustment during testing in order to secure the desired system performance characteristics. However, if 'hit and miss' experimentation is to be avoided, the provision of adequate system diagnostic instrumentation is obviously essential.

It is evident that the ON and OFF times may have to be varied in flight to cater for changing atmospheric icing and temperature conditions. This can be done manually while monitoring the relevant performance parameters in flight. However, in service, an automatically controlled system is clearly much more desirable to reduce aircrew work load. The Wessex development system therefore incorporates two facilities: an Automatic Mode in which the system operating parameters are controlled by a temperature sensor and an icing severity computer; and a Manual Mode in which the ON and OFF times can be selected manually as required for test purposes. Definition of any automatically controlled system is almost certain to involve a significant amount of development flying in a Manual Mode in order to investigate and optimise the heater ON and OFF time control 'laws' required.

With the system shown in Figure 1, the basic ice removal periodicity is given by:-

$$T_p = (n \times T_{ON} + T_{OFF})$$

where T_p = ice removal periodicity

n = number of segments

T_{ON} = ON time per segment

T_{OFF} = OFF time per cycle

With zero OFF time, eleven segments and the nominal ON time characteristic, the shortest ice removal periodicity would be 33 seconds at 0°C increasing to nearly 4 minutes at - 20°C.

It should be noted, however, that at the present state of knowledge in the industry as a whole, neither the heater mat dispositions nor the heater sequencing to achieve the required ice removal can be considered to be firmly established or standardised and it may be that, in order to meet specific requirements, future rotor ice protection systems will incorporate heater mat and sequencing arrangements not seen in current systems.

Even with the fixed heater mat layout illustrated in Figure 1, a large range of cycling options can be devised e.g. shortened cycles by deletion of segments, giving a more frequent ice removal capability; or, the heating of some segments twice per cycle or, alternatively, once every second, third, fourth cycle etc.

The cycle switching arrangements and control logics in the Wessex system were designed originally to meet fairly simple basic requirements. However, as testing has proceeded, requirements for sequence changes and special cycles for trials purposes have emerged. The Lucas switching and control system has proved to be very versatile in meeting these requirements, fairly radical sequencing changes being possible with relatively minor system changes, selectable either on the ground by means of plug-in loom unit changes, or, for specific tests, using an in-flight segment inhibit facility.

As previously stated, comprehensive flight instrumentation is essential if the results of the trials flying are to be interpreted with confidence.

Principal Instrumentation fitted is as follows:

- (1) Main and tail rotor system strain gauging - hubs controls and blades including in-flight main rotor starload monitor.
- (2) Full flight performance and handling parameter recording.
- (3) Rotor head and tail boom cameras.
- (4) Icing Instruments - vernier accretion, Leigh, Rotating Disc.

Further information on the instrumentation equipment is given in References 4 and 5.

4. TESTING IN THE NRC SPRAY RIG

Because of the relative ease and convenience with which testing can be carried out in artificial icing rigs, compared with the operational complexity and weather frustrations intrinsic in carrying out flight testing in natural icing cloud, the NRC Spray Rig at Ottawa has for many years played a prominent part in the initial evaluation and, in some cases, certification of rotor blade ice protection systems.

Use was made of the NRC Spray Rig during the initial assessment of the basic Wessex development system during trials in Canada in 1972/73 and 1974. The temperatures and liquid water concentration conditions examined are summarised in Figure 3. Testing was broadly in accordance with the standard Spray Rig procedure, liquid water content being varied as necessary, in accordance with the ambient temperature of the day, to build up a matrix of test points for system validation against the Design Icing Standards. Over the two seasons, a fairly comprehensive coverage of test conditions was achieved and in 1974 the opportunity was taken to extend the spray rig testing L.W.C. beyond the Design standard maximum continuous concentration levels.

During Rig testing, de-ice cycle ON and OFF times were introduced manually, since the on-board temperature and icing severity instrumentation used to control the system in the Automatic Mode had been found to give erroneous indications in the spray rig environment.

The ON times operated were substantially in accordance with the nominal design ON time - ambient temperature characteristic (Fig.2), the basic eleven segment switching cycle of Figure 1 being in use. Some additional tests were also introduced to assess the tolerance of the ice shedding processes to ON times which were greater or less than the nominal ON time characteristic.

The heat OFF times tested were generally in the range 2 minutes to 6 minutes, assessment of the system performance during this phase of testing being against the then popular "critical ice shedding thickness" philosophy. As a result of early investigations it was at that time considered to be highly desirable, or even essential, that the cyclic blade de-icing operating criteria should be based on a certain minimum thickness of ice on the blade (7-8 mm.) in order to achieve satisfactory ice shedding without incurring the risk of runback re-freezing resulting from premature heating.

Assessment of the performance of the system, and the effectiveness of the ice removal processes during spray rig testing was based on information from the following sources:

- (i) Rotor system torque, control load and aircraft vibration characteristics were monitored during hovering tests in the Spray rig.
- (ii) The rotor blades were examined for evidence of residual ice accretions after each test condition.
- (iii) Rotor system strain gauge and flight handling parameter trace records and rotor blade photographs were correlated with the system operating parameters and timing sequences.

During this phase of testing, experiments were also introduced to investigate the capabilities of the system in circumstances of delayed cycle initiation, half cycle operation (i.e. de-icing, for comparison purposes, of only one pair of blades) and investigation of forward flight performance degradation effects, in clear air, following accretion in the spray rig with the de-icing system inhibited.

The spray rig test programme confirmed the adequacy of the heater mat power intensities and the heat ON times in use. The rotor blades were substantially free of ice after all test runs and there was encouraging evidence, during flight in the spray rig, of rotor torque variations which correlated logically with the de-icing cyclic sequences. Rotor blade stresses and control loads remained at acceptable levels at all times.

From this work it could have been generally concluded that, within the conditions tested, there was evidence of satisfactory ice shedding performance and there is little doubt that at one time the evidence of this type of testing could have been put forward in support of System Airworthiness Certification applications.

However, a more critical engineering assessment of the Spray Rig work, both in its own right, and also in the light of flight experience obtained concurrently in natural icing conditions, highlighted a number of extremely important technical factors:

- (i) While the rotor torque variations observed in flight provided evidence of the effectiveness of the de-icing system, the levels of torque increase encountered between de-ice cycles with the de-icing periodicity under test (ranging from 5 minutes at 0°C to 7 minutes or more at -20°C) were observed to be as high as 500-600 lb/ft, representing 20-25% of the torque required to hover in non-icing conditions. Rotor theory, confirmed by test experience with protected and unprotected rotor systems in natural icing conditions, predicts that the torque increments recorded in hover will increase significantly in forward flight due to the fundamental influence of rotor aerodynamics in forward flight, compounded in some speed and manoeuvre circumstances, by additional torque increments due to premature blade stall effects induced by rotor blade ice accretions. Furthermore, flight experience has shown rates of initial torque increase (Figure 7) which are substantially in excess of anything recorded during spray rig testing. By implication, the foregoing factors would also be expected to have a major influence on the forward flight dynamic stall boundaries of the rotor system during ice accretion and de-icing. From a helicopter engineering standpoint, it was evident that the large ice accretions on the rotor blades intrinsic in long period cycling were most unlikely to be acceptable, aerodynamically, during forward flight operation.
- (ii) There was frequent evidence of random ice shedding, prior to de-icing system initiation, during testing in the spray rig, the result possibly of self shedding of large ice accretions or else due to blade flexing and rotor control disturbances arising from turbulent conditions in the vicinity of the rig. Under such conditions the inference of the shedding evidence could be misleading.
- (iii) Further developments in rotor blade photography and other instrumentation were required to support investigation of the ice removal processes.

The spray rig test results were therefore viewed with caution, being regarded essentially as a preliminary demonstration of system capability and operating integrity prior to testing in natural icing conditions.

5. TESTING IN NATURAL ICING CONDITIONS

At the outset it was recognised that the airworthiness proving of the helicopter equipped with the rotor ice protection system could not be based solely on Spray Rig testing and that a significant amount of trials flying in natural icing conditions would be required.

The flight altitudes and temperatures experienced during the trials periods are summarised in Figure 4. Also indicated in Figure 4 are the flights on which particularly severe icing conditions were encountered, icing severity being deduced from the icing instrumentation and performance degradation characteristics experienced. Fig.5 gives details of the liquid water concentration encountered during the 1977/78 trial based on the Rotating Disc, Vernier accretion and Leigh icing meters (Ref.5).

Inevitably, because of the variable nature of natural icing cloud, a proportion of icing flying takes place in conditions of only light to moderate severity. Since many helicopter rotor systems exhibit some flight capability without rotor protection in light to moderate icing, the results of trials flying in these conditions may be of only limited technical significance when the total capability of an ice protection system in critical icing conditions is under investigation. It is therefore important that the severities and technical relevance of the conditions in which icing trials flying takes place be properly identified, when the airworthiness and performance characteristics of the system are being assessed.

At an early stage in the development, we were fortunate in encountering potentially limiting icing severities on several occasions, sometimes transiently and, on other occasions, liquid water concentrations equivalent to Design Standard Maximum Continuous concentrations have been encountered for extended periods. The results of these flights are of considerable technical significance and have important implications on the design, testing and certification of rotor blade ice protection systems.

All trials flights in severe icing conditions have exhibited similar characteristics: rapid and large increases in rotor torque, coupled with substantial increases in rotor system control loads, have been experienced on first entering severe icing. Initiation of the rotor protection system invariably provided immediate alleviation by reducing the rotor torque and control loads to near datum levels. However, during subsequent cycling of the system, further increases in torque and rotor control load occurred between de-ice cycles, due to re-accretion, as seen in Figure 6. Although the parameters show clear evidence of the effectiveness of the ice shedding process, the resulting fluctuations in rotor control load and rotor torque - some 800-900 lb.ft., representing 40% increase over the non-icing flight requirement - are considered to be excessive for routine operation since such circumstances would require a significant reduction in flight speed to protect rotor component fatigue lives, and a major diversion of aircrew workload to monitor and control the de-icing functions.

The ice removal periodicities in operation in Figure 6 - some 80 seconds cycle time together with OFF times of 20 to 30 seconds - are evidently too long to cope effectively with these levels and rates of rotor blade icing and performance degradation.

Some impression of the rates of performance degradation which must be catered for in rotor icing protection system design may be gained from the flight time history of Figure 7 (taken from Ref.3). These data were obtained on a Wessex helicopter flying in natural icing conditions without rotor icing protection. On this occasion, an increase in rotor torque, due to rotor icing, at the rate of 900 lb.ft. in 20 seconds was experienced. In such circumstances, a basic de-icing periodicity of 2 minutes, or longer, as traditionally postulated and widely practiced, would clearly be inadequate to maintain satisfactory standards of rotor and helicopter performance.

Such rates of performance degradation also impose very stringent requirements on automatic control system design and on the characteristics of the icing sensors and severity systems which may be required either to initiate the operation of the protection system or to adapt its operating characteristics to meet variable icing severity requirements in flight.

Although these rotor torque characteristics in forward flight are judged to be unacceptable as a certificated operational standard and imply a failure of the cyclic de-icing philosophy, as originally propounded, to cope with operational icing conditions, the results are not completely unexpected both from theoretical aerodynamic considerations and also from the torque increases observed during testing in the Spray Rig. There are also many possible modifications to the basic cycling sequence which could confer substantial improvements in rotor performance during system operation in severe conditions.

Following early identification of this important aspect of cyclic rotor de-icing operation, development work has concentrated particularly on improving the system to cope with critical requirements without a need for complex de-icing mode changes during flight. This has entailed reappraisal of traditional concepts of optimised 'run-back free' cycling criteria and exploration of revised cyclic sequences and heating times based upon detailed interpretation of the ice accretion and removal processes and correlation of strain gauge results (Figure 8) and consolidated flight and system performance characteristics (Figure 9). From such studies it has been clearly established that rotor blade leading edge cycling plays a key role in controlling the rotor performance characteristics.

6. CYCLE DEVELOPMENT POSSIBILITIES

There is now a need to speed up both the initiation signalling and the de-icing function of the rotor protection system in critical icing conditions. This can be achieved in various ways either by adjustment within the de-icing cycle itself or by re-appraisal of the ice shedding sequences employed.

The most obvious method of speeding up the ice removal process is by reducing the number of steps in the cycle or by reducing energising ON time (see Section 3) provided that, in so doing, the efficiency of the ice shedding process is not impaired. Further reduction of cyclic time after optimisation of heater ON time and heated area, would require either an increase in power intensity and/or increase in segment areas to reduce the cycle length.

In the event of an 'optimised' updated or shortened cycling system proving inadequate to achieve the desired performance in critical icing conditions, recourse might have to be made to 'compound' or 'hybrid' mixed anti-icing/de-icing systems in which preferential repeat cycling or continuous heating of key areas of blade could be introduced within the total de-ice cycle.

Some examples of possible modifications to the basic system are shown in Figure 10.

It must be realised that system changes of this type constitute significant departures from the cycle concepts previously tested and judged to be free from adverse side effects such as runback ice and longer term performance degradation. There is clear evidence from flight tests that, if suitable measures are not taken to prevent or control runback ice, serious medium/long term performance deterioration can result during continuous cycling of a simple short period ice removal sequence in high liquid water concentrations. In view of this, it is considered essential that all major changes in system operating philosophy be strictly monitored during flight to ensure that the chosen solution is compatible with all operating requirements.

7. THE WAY AHEAD

Substantial progress has been made with this programme: potentially critical natural icing conditions have been scientifically explored and it is concluded that the simple, classic, ice shedding criteria and ice removal periodicity evolved during Spray Rig testing are inadequate to support satisfactory operation in critical icing conditions.

Following a review of classic cyclic ice removal patterns, modified ice protection sequences have been evolved with the specific objective of achieving substantial alleviation of the stringent de-ice time factor intrinsic in de-icing systems in current use. This approach to rotor ice protection will not only reduce the critical nature of the cyclic timing required but will also contribute to a substantial simplification of the ice detection and control logics required.

Testing of these modified systems is continuing and it is confidently expected that this activity will lead, in the very near future, to a fully automatic, scientifically flight proven, ice protection system conferring unrestricted icing flight capability throughout the operationally relevant flight and icing envelopes.

References

1. "Canadian Research in the Field of Helicopter Icing"
Stallabrass
Helicopter Association of Great Britain, May 1958.
2. "Westland Wessex De-Icing Trials Part 2
Tests on Spraymat Cyclic Electrical De-Icing System"
Ballard and Saunders
Napier Report DEV/R/411/466/1 1961.
3. "The Problem of Certifying Helicopters for Flight
in Icing Conditions"
H.B. Lake, J. Bradley
R.Ae.S Symposium November 1975.
4. "Techniques for Icing Test Flying"
G.V. Ray
NATO Panel x Symposium November 1978.
5. "Icing Instrumentation"
Booker and Barlow
NATO Panel x Symposium November 1978.

TABLE 1
Summary of Wessex Heated Rotor Blade
Flight Development Experience

| SEASON | 1972/73 | 1974 | 1976 | 1977/78 | TOTAL |
|----------------------|--------------------|--------------------|----------------------|----------------------|---------------|
| Trial Location | Uplands, Canada | Uplands, Canada | Tirstrup, Denmark | Tirstrup, Denmark | |
| Period of Flts. | DEC-FEB | MARCH | FEB-MARCH | NOV-FEB | |
| <u>NRC SPRAY RIG</u> | | | | | |
| No. of Flights | 27 | 11 | - | - | 38 |
| Time in Cloud | 5 hrs 33 min | 5 hrs 11 min | - | - | 10 hrs 44 min |
| <u>NATURAL ICING</u> | | | | | |
| No. of Flights | 9 | 5 | 15 | 29 | 58 |
| Time in Cloud | 9 hrs 37 min | 3 hrs 31 min | 12 hrs 15 min | 14 hrs 3 min | 39 hrs 26 min |

Note In addition to the above Wessex flying specifically on Heated Rotor Blade Development, 71½ hours of documented flying time in Natural Icing Conditions (127 Sorties) have been logged by Wessex helicopters, without rotor protection, engaged on other aspects of icing development (Ref.3).

**Testing in NRC
Spray Rig**

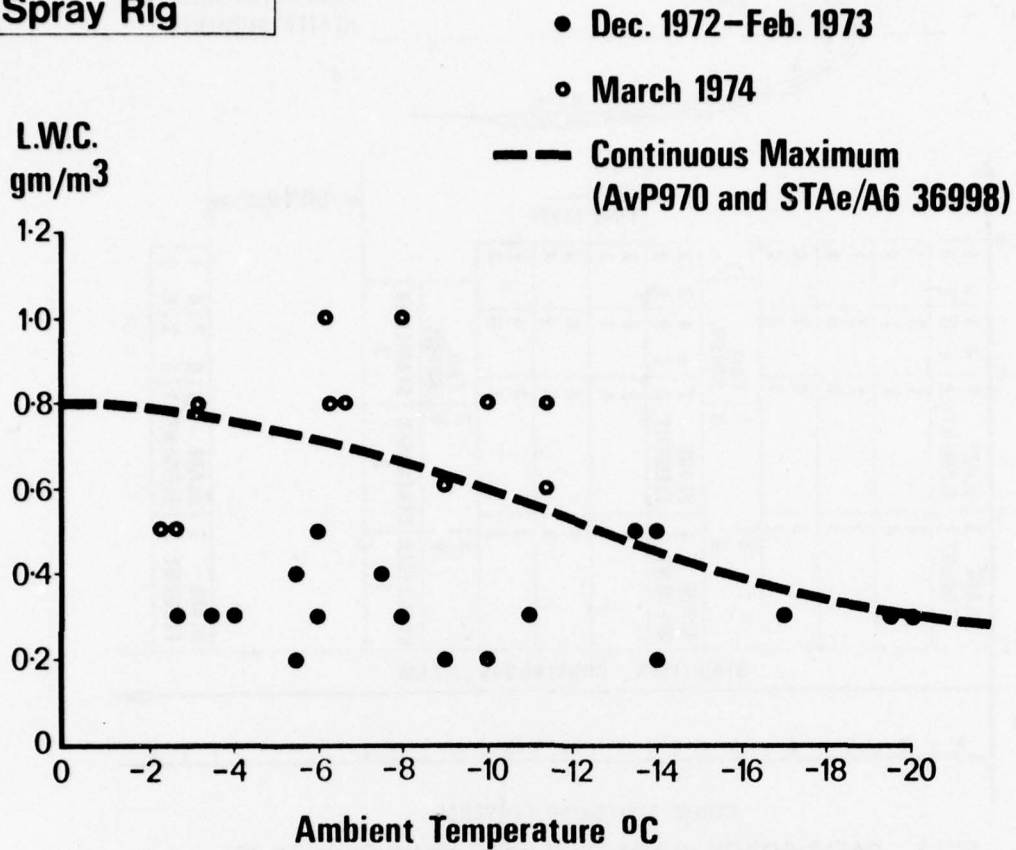

FIG.3. SUMMARY OF TESTS IN NRC SPRAY RIG

Testing in Natural Icing Conditions

- Canada | Jan. – Feb. 1973
- ⊙ Canada | March 1974
- ◐ Denmark | Feb. – March 1976
- Denmark | Nov. 1977 – March 1978
- Flight in Heavy Icing Conditions and Technically Significant Flight

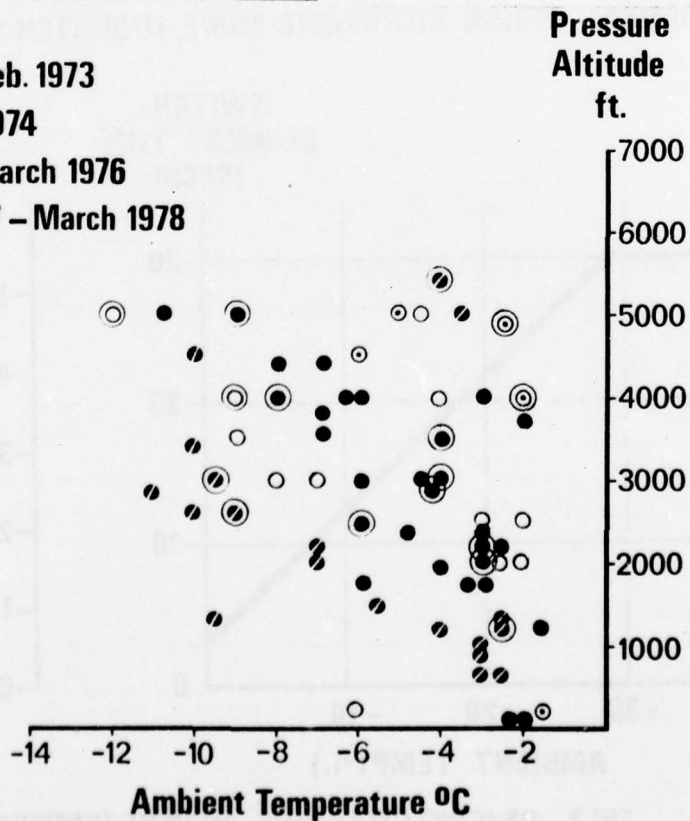

FIG.4. SUMMARY OF TESTS IN NATURAL ICING CONDITIONS

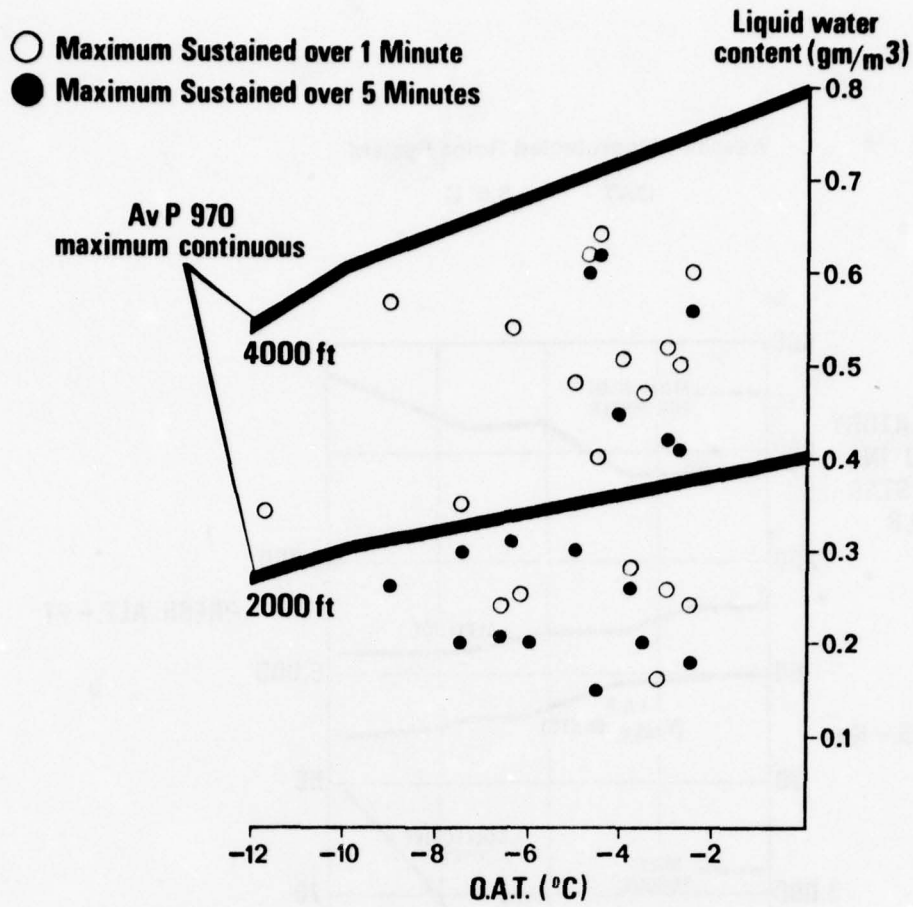

FIG.5. NATURAL ICING CONDITIONS 1977/78

WESSEX HEATED ROTOR BLADE SYSTEM
4900 FT PRESSURE ALTITUDE
80 KTS IAS
-2°/-3°C AMBIENT TEMPERATURE

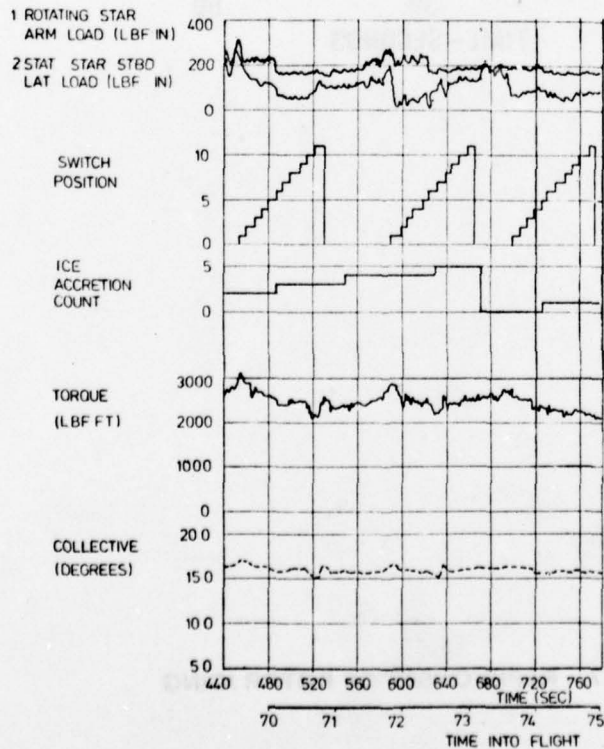

FIG.6. TYPICAL SYSTEM OPERATING CHARACTERISTICS IN SEVERE NATURAL ICY CONDITIONS (CANADA 1974)

Wessex - Unprotected Rotor System

OAT - -3.5°C

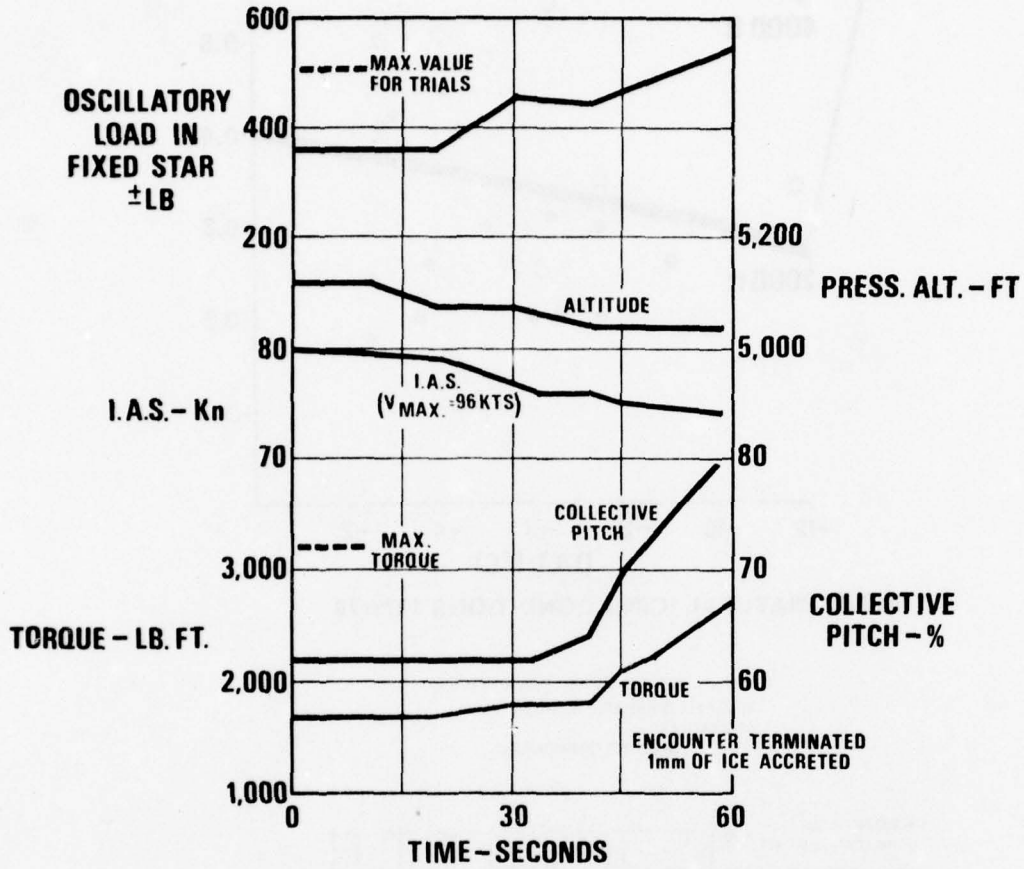
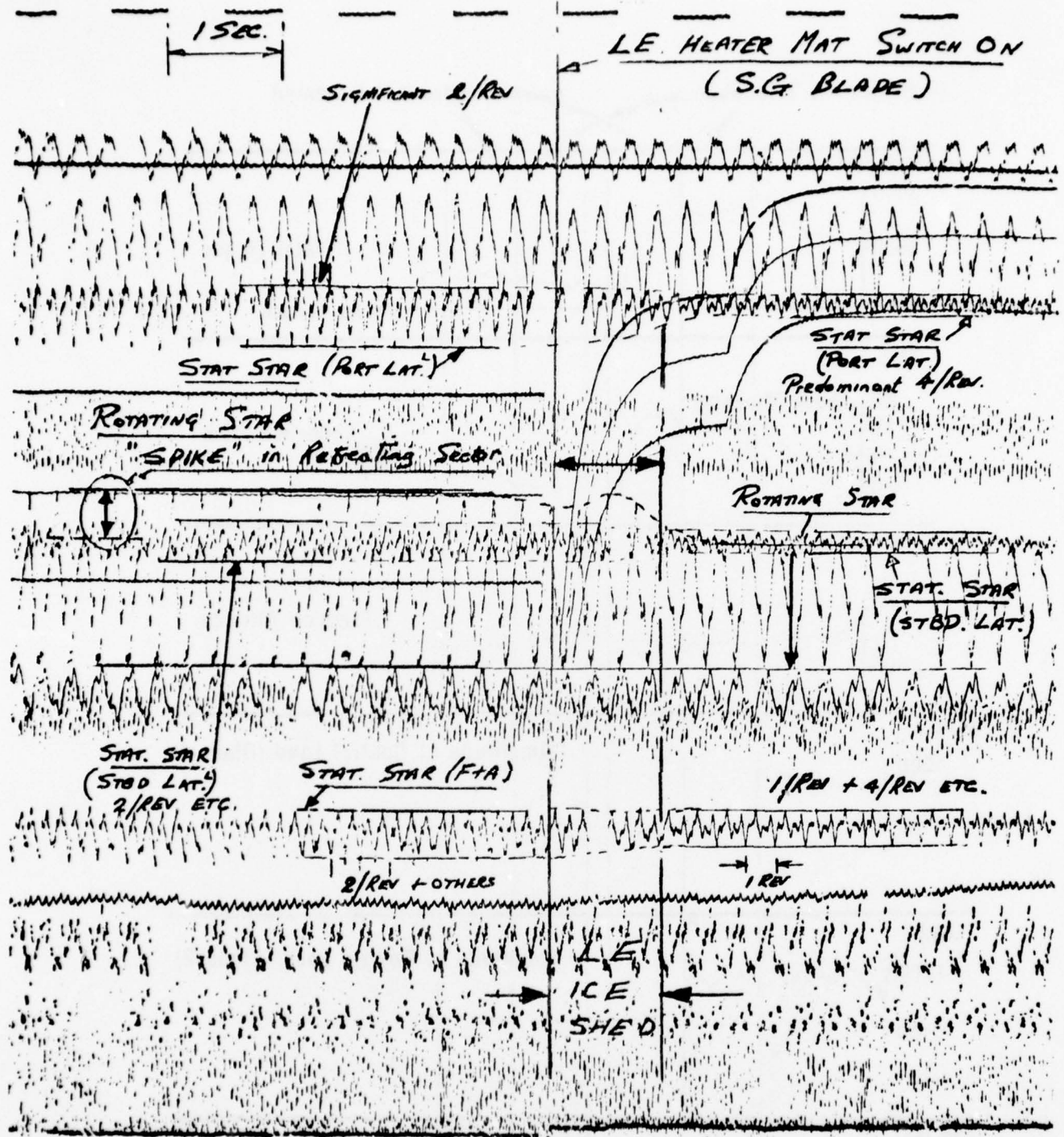

FIG.7. RAPID ONSET OF ROTOR ICING



TYPICAL CONTROL LOAD HISTORY - L.E. ICE SHED

FIG. 8. STRAIN GAUGE TRACE

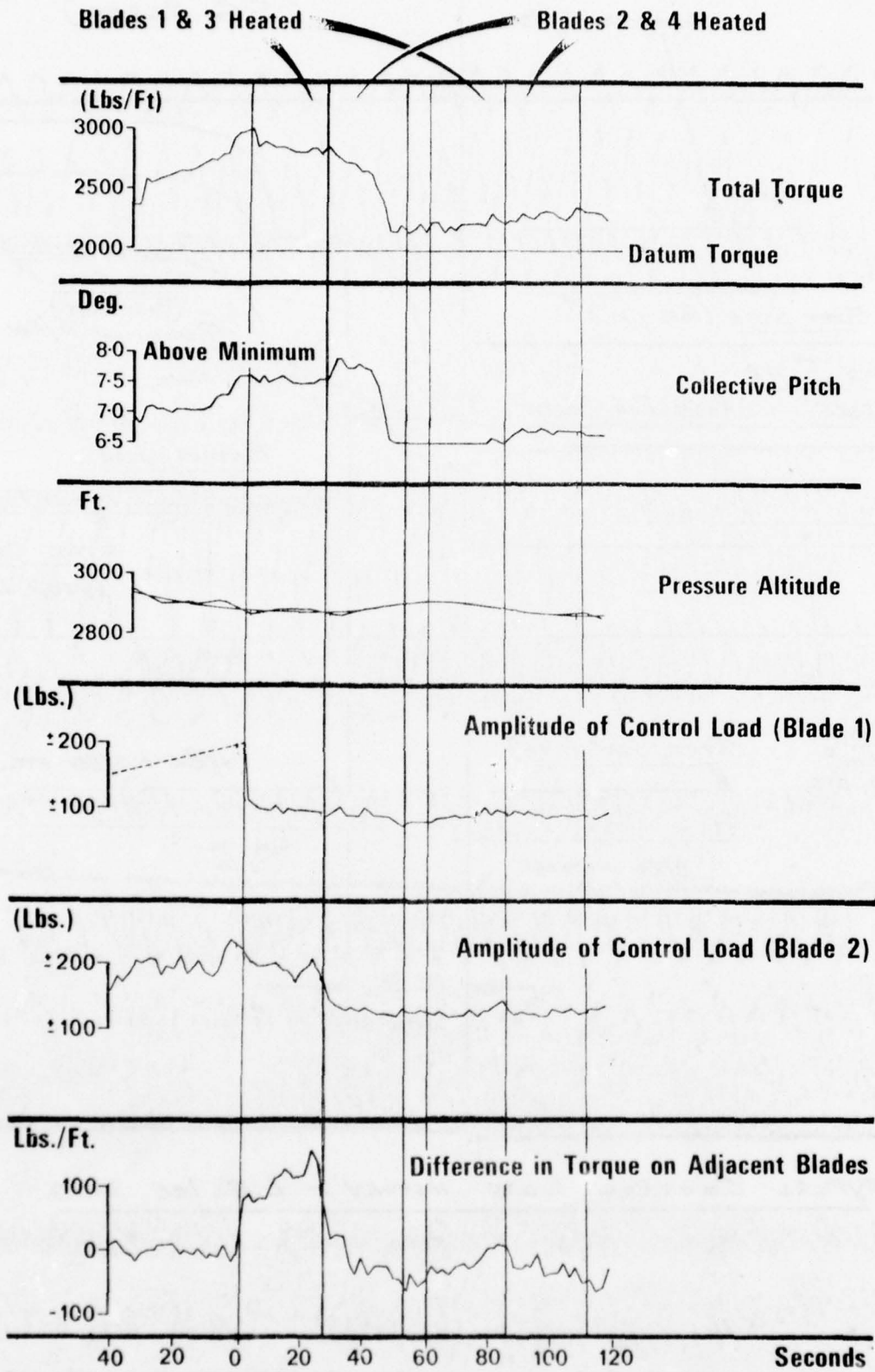
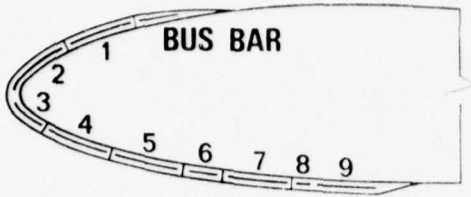

FIG.9. FLIGHT TIME HISTORY AT INITIATION OF BLADE HEATING



| OPTION | 1 | 2 | 3 | 4 | 5 | 6 | 7 | 8 | 9 | 10 | 11 | 12 | 13 |
|--------|---|---|---|-----|--------------|---|------|---|------|----|----|----|----|
| I | 2 | 4 | 5 | 2 | 4 | 5 | STAB | | | | | | |
| | 3 | 1 | 6 | 3 | 1 | 6 | STAB | | | | | | |
| II | 2 | 4 | 5 | 2 | 2 | 4 | 5 | 2 | STAB | | | | |
| | 3 | 1 | 6 | 3 | 3 | 1 | 6 | 3 | STAB | | | | |
| III | 2 | 4 | 5 | 7 | 2 | 4 | 5 | 2 | STAB | | | | |
| | 3 | 1 | 6 | T/R | 3 | 1 | 6 | 3 | STAB | | | | |
| IV | 2 | 4 | 2 | 4 | STAB | | | | | | | | |
| | 3 | 1 | 3 | 1 | STAB | | | | | | | | |

◀ BLADES 1 & 3 | BLADES 2 & 4 ▶

X SEGMENT INHIBITED

FIG.10. MODIFIED CYCLE OPTIONS

The Rotor Blade De-Icing System on the
Messerschmitt-Bölkow-Blohm Helicopter BO 105

INTRODUCTION

During the Rotary Wing Icing Symposium in June 1974 at Edwards Air Force Base a presentation was given on the Bölkow BO 105 ice protection system and a report on the test results of the test campaign during the winter of 1973/74 in the NRC ice rig in Ottawa and of flights in natural icing conditions in Canada [17].

The fact that now, after four years, we are again reporting on the completely unchanged BO 105 rotor blade de-icing system is due to the following reasons:

- the components of the system are now almost five years old, so that data on the reliability and the amount of repair and overhaul are available.
- The system has now been tested in natural icing conditions in Germany, and a great deal has been learnt in general about helicopter flights in icing conditions, upon which we shall be reporting.
- Last, but not least, the presentation of the various new developments in the rotor blade de-icing systems used by our NATO partners should not lack another description of our own development, since it is still regarded, even now, 5 years after its completion, as a very modern and effective system.

We make no secret of the fact that, up to now, this system for the BO 105 has not been series-produced. The BO 105 will be going into service with the German Army as an LOH and ATH, but without IFR equipment, so that rotor blade de-icing is not planned.

As the system has fundamentally proved successful, its use with helicopters of future generations, especially SAR craft, is under consideration.

At this juncture, the author would thank the flight test engineer at Manching Proving Ground, Mr Kurt Uwira, for the compilation of the test results and statistical data.

Icing Conditions - the Present Problem During the Winter in Germany

Climatically Germany is situated in the marginal area between the humid, mild maritime Atlantic climate and the dry continental climate, hot in summer and very cold in winter. In this mixed zone there is frequent fluctuation between maritime and land weather conditions. The winter frequently produces icing conditions, the frequency of which is reported upon in studies conducted by the Military Geophysical Office 27.

Let us take a few figures to demonstrate just how acute these problems are for helicopters. The Sea King Mark 41 search and rescue helicopter of the GNY is at present not licensed to fly in icing conditions. Its theatre of operations is the coastal areas of the North Sea and the Baltic. On 60 days during the period between 20 Nov 77 and 15 Mar 78 weather conditions were forecast in which the regulations of the GNY prohibited flights with this type of helicopter due to the icing hazard. This led to the rejection of 22 urgent appeals for help 37.

In the entire SAR service of the German Forces, 90 SAR flights had to be cancelled due to icing conditions between 1 Oct 77 and 31 Mar 78 47.

The BO 105 Anti-Icing System

I hope those of you who were at the Rotary Wing Icing Symposium at Edwards AFB in 1974 will bear with me if I now repeat the description - albeit in somewhat abridged form - that you heard there. There have been no changes at all in the system. We assume that there will be a lot of engineers and officers at the 1978 Helicopter Icing Symposium in London who are unaware of the Edwards papers.

The BO 105 is a light twin engine 5 seat multi purpose helicopter with a maximum gross weight of 2,300 kg. The main data are summarized in Fig. 1.

The test helicopter is a production version, but with IFR equipment and an anti-icing system which covers:

- the engine intake anti-icing system and protection,
- the heated pitot tubes,
- the electrically heated pilot's windshield,
- a rotor de-icing system for the fiberglass rotor blades (main and tail rotor), and
- ice detectors.

The engine air intake is protected by what is termed a snow and ice deflector in front of the plenum chamber (Fig. 2). The air, before entering the plenum chamber, is deflected 90° downward in front of the main rotor gear box by this deflector. Thus snow and ice particles are deflected to the engine deck. The bleed air heated compressor intake behind the gear box, 160 inches above the engine deck, does not suck in snow or ice lying on the deck.

The pilot's windshield, supplied by Lucas Aerospace, is electrically heated by three-phase $.43 \text{ watts/cm}^2$ (Fig. 3). The specific power is alternating current.

The present rotor de-icing system (main and tail rotor) is specified to operate down to -18° C; its total weight is 12 kg without power supply and wiring. The heater elements are of the spraymat type, made by Westfälische Metallindustrie (WMI), the German licensee of Lucas Aerospace, UK. The d.c. control system was developed by AEG-Telefunken, Germany. Each rotor blade has 6 spanwise heater elements in the leading edge under the steel erosion protection shield, which are powered by 280 volts d.c.

Figure 4 shows the spanwise specific power distribution on the fiberglass rotor blades. In two opposite blades of the four bladed rotor the corresponding mats are energized simultaneously to maintain symmetric ice shedding (Fig. 5).

The tail rotor also has 6 heater elements with a specific power of 2.64 watts per square cm. All the mats are energized simultaneously with every 4th step of the heating cycle.

The heater ON time can be selected by hand and is infinitely variable between 2 and 24.5 seconds, while the heater OFF time, the time between the end of one heating cycle and the beginning of the next, can be selected between 0 and 130 seconds.

The airfoil sections of the main and tail rotor blades do not differ from the production blades. The heater mats are built into recesses in the blades' surface.

Fig. 6 shows the sequence in which the elements of the main and tail rotors are heated.

The AEG-Telefunken d.c. control system consists of the following components:

- The control unit, mounted in the right rear side of the fuselage between the frame behind the fairing, as shown in Fig. 7. It contains

- o the thyristor rectifiers to rectify the power from the alternators to 260 volts d.c.,
 - o the module for controlling the heating sequence of the mats,
 - o the thyristor contactor switching the power ON and OFF without any mechanical contact,
 - o the monitoring system for over and under current, short circuit, sequence control, and element ON time, and
 - o the only mechanical component in the whole control unit, a cooling fan.
- The cockpit mounted control panel for switching ON and OFF the rotor de-icing system is shown in Fig. 8. It includes the knobs for the selection of heater ON time and OFF time.
 - The electronic stepping switch on the main rotor head distributing the power to the heater elements in the blades, as illustrated in Fig. 9. It has no mechanical components at all.
 - The slip ring assemblies, with 3 slip rings on the main rotor and 2 slip rings on the tail rotor, for the d.c. power transfer is illustrated in Fig. 10. In the experimental system, the main rotor slip ring assembly has 22 additional slip rings used to transfer temperature sensor data.

The installation areas are shown in Fig. 11. Power in the test helicopter is supplied by two alternators, each driven by one engine.

One alternator feeds the rotor de-icing system. The power required by both rotors is 5.7 kilowatts. The other one feeds the cabin heating (4.0 kVA) and the electrically heated windshield (2.1 kVA). In an emergency, for instance if one engine fails, one alternator feeds the de-icing system, half the cabin heating, and the lower part of the heated windshield.

The production helicopter with a de-icing system would have one 10-12 kVA alternator directly driven from the main rotor gearbox.

A fundamental diagram of the electric components is shown in Fig. 12.

The weight breakdown of the present test version and the production version is shown in Fig. 13.

In the production version, the complete anti-icing system, including one 12 kVA alternator, will come to about 32.5 kg.

Four ice detectors were installed. One Rosemount and one Teddington on the roof in front of the engine air intake and one Teddington and one Rosemount on the lower front part of the fuselage.

I should point out that the only mechanical components of the system are:

- the generators,
- the three slip rings on the main rotor and the two slip rings on the tail rotor,
- control switches on the pilot's control panel for turning the system and the heater time on and off, and
- the cooling fan for the control unit.

There is no further mechanical contact and no relay within the system, which is considered a great advantage.

When equipped with this ice protection system the helicopter has full clearance for flights in moderate icing conditions down to -18° C. The test crew reported that they always felt great when flying around in the icing clouds whereas all the other aircraft had to stay on ground.

Aim of the Continuation of the Testing of Our System
in Natural Icing Conditions in Germany

The aim of the tests in natural icing conditions in Germany after the very successful 1974 campaign in Ottawa is the following:

- to acquire experience with the system
- to determine relations between measured meteorological data and measured engine power on the one hand and optimized heater ON and heater OFF times for the heater mats on the other, which should be set automatically, if possible.

Optimized heater ON and heater OFF times are found, if during a flight in icing conditions only a neglectable increase in engine power is required to maintain flight level and speed.

If unsuitable heater ON and/or heater OFF times are chosen, there is either no clean ice shedding or there is too much ice accretion before shedding, which may result in an unsymmetric self-shedding or in a loss of energy, or there is produced liquid water which freezes as run back ice at the unprotected areas of the rotor blades. In all three cases more engine power is needed, if the flight level and the speed shall be maintained.

Observations During the Flights in

Natural Icing Conditions

The tests have shown unequivocally that in particular the heater ON time for the individual heater mats must be adapted closely to weather conditions. Run back ice on unheated rotor blade surfaces constitutes a permanent, irreversible deterioration of the aerodynamic blade profile during the respective flight. A system which only permits, for instance, setting the heater ON time in two steps (fast, slow) is therefore considered with great scepticism. The control of heater ON and heater OFF times should be automatic, continuous and dependent of weather conditions.

While the correct heater ON time was found to depend exclusively on outside air temperature (OAT), the dependency of the heater OFF time, i.e. the time between the end of one heating cycle and the beginning of the next cycle, on weather conditions, is more complicated, which will be reported later.

In our test system the rotor de-icing system is switched on manually, and the heater ON and heater OFF times are selected manually by the flight test engineer.

What indications were given to the crew to activate the protection system?

During a stabilized flight, i.e. at a constant pitch and a constant r.p.m. the torque (engine power) will reach a certain value, which depends on the gross weight, the flight level and on outside conditions.

Reliability of the Rotor Blade De-Icing System

All components of the rotor blade de-icing system were delivered by the manufacturers MBB, AEG and WMI at the beginning of December 1973. Since that time the components have been on/in the helicopter.

The number of flight test hours of our test helicopter in that time was not very high, but never was the de-icing system the reason for this.

The boundary conditions imposed on the test center at Manching did not allow a flexible testing that was not restricted locally. In the area of Manching icing conditions during recent winters have been much less frequent than for instance in the coastal areas of the North Sea and the Baltic.

From January 1974 to 31 May 1978 the following figures were reached (Fig. 14):

| | |
|--|---------|
| - number of flights | 268 |
| - number of test flights | 108 |
| - overall flight hours, identical to mechanical operation hours of the system: | 166 hrs |
| - electrical operation time of the system during flights: | 25 hrs |
| - number of heating cycles during flights: | 832 |

The resistors of the heater mats of the main rotor were within the tolerance of $9.42 \text{ Ohm} \pm 5 \%$ also at the last control on 6 July 78. The insulation resistance between two heater elements and also between one mat and mass has always been greater than 50 M Ohm as required.

Throughout the period from January 1974 to July 1978 the following repairs were carried out on the system:

- Strengthening of the mechanical parts used for fastening the additional brushless alternators (test installation) (Fig. 15)
- Replacement of mounting for one of the six brushes at the three main rotor slip rings
- Repair of a short circuit in the electronic stepping switch, caused by a wire used by an electrician to change from 5 to 3 heater mats per blade during the Ottawa campaign.

All components work perfectly; there has been no overhaul, and a change of brushes on the slip rings has not been necessary either. These encouraging results are reached due to the almost complete absence of mechanical components in the system.

Summary

After almost five years of experience with the unchanged rotor blade de-icing system of MBB/AEG/WMI/Lucas the system can be said to function perfectly. The reliability of the system, which is unusual in a prototype, and the almost completely maintenance-free operation are ensured by keeping the number of mechanical components to a minimum. To relieve the crew series production should provide for an automatic selection of heater ON and heater OFF times.

Although the Rosemount ice-detector was working satisfactorily the test crew found that the change of torque was the most reliable and safest indication of the degree of icing of the helicopter.

As soon as there is an ice accretion on the fuselage or on the rotor blades, the torque rises , and more power is needed to maintain flight level and speed.

Our test helicopter reached, during stabilized flight, a torque of 50 to 55 % if there was no ice accretion. Due to the gearbox, the torque is limited to 79 %. As soon as the torque reaches, during a stabilized flight in a cloud, a value of 65 %, the rotor blade de-icing system is switched on. Due to the controlled ice shedding of the rotor blades the torque decreases, but not to the initial value, since a slightly iced fuselage and rotorhead deteriorate the aerodynamic conditions of the helicopter.

The torque raise per time unit is the very best indicator of the severeness of the icing condition. In heavy icing conditions the torque was found to rise from 50 to 79 % in 120 to 150 seconds.

The heavier the icing conditions and the more ice accretion, the shorter must be the OFF time between two cycles. In our next tests we, therefore, want to find out whether the heater OFF time can be selected automatically as a function of the change of torque.

The optimized heater ON time for a heater mat is, as stated before, a function of the OAT. In a series production unit it therefore can be controlled automatically.

While at the Edwards symposium we still reported that flights in icing conditions in the temperature range of 0 to -5° C are possible without any rotor de-icing system, we found out in the meantime, during some longer flights in those conditions, that after 15 to 20 minutes the rotor de-icing system has to be heated during one cycle if the flight level shall be maintained.

During test flights in Germany, like in Canada, the rotor blade de-icing system worked perfectly and enabled the helicopter to fly without difficulty in prevailing icing conditions.

However, one of the test flights, on 23 March 1978, had to be finished prematurely by the crew due to failure of one of the two engines. Since the helicopter was near its home base the crew made no attempt to restart the engine but landed on that base.

An investigation of the failure revealed the following: At the time of engine failure the helicopter was flying at an OAT of -6.5° C in a snowfall area immediately below the cloud ceiling. The rotor blade de-icing system was not switched on. There was no accretion of snow or ice on the rotor blades, whereas a 2 cm. layer of wet snow had accumulated on an area of approximately 0.5 sq.m. on the front side of the fuselage. The gear cover near the rotor mast has a recess the size of a fist which during test at Ottawa accommodated a measuring instrument. Since the inlet of the inoperative engine is located below this recess it is assumed that wet snow which had come off the fuselage had penetrated the engine ingestion area through this recess. This assumption is supported by the fact that the compressor of the inoperative engine looked as if it had been washed and that slush was still lying on the bottom below the engine inlet. The engine was not damaged. The recess in the engine cover has in the meantime been closed, and to increase the safety of the crew the ingestion area of the engines will in future be monitored optically.

Since the retrofitting of a helicopter with an icing protection system always constitutes a heavy interference with the weapon system the user should clearly express in the general staff target for future helicopters whether the weapon system is intended to fulfil missions in icing conditions. If this is the case, provisions for a protection system must be included in the concept from the very beginning. The user should consider the technical consequences of his requirement and take into account the means and time required for the adaptation and qualification of the icing protection system. It is very much appreciated for these reasons that the user availed himself so frequently during this symposium of the opportunity to inform himself on installations required to qualify a helicopter for flights in icing conditions.

References

- [1] Dipl.Ing. Albrecht Horlebein and LTC Dipl.Ing.
Hans Melcher
The BO 105 Ice Protection System
USAAEFA Project No 74-77 Rotary Wing Icing Symposium,
Summary Report Volume III, June 1974
- [2] Amt für Wehrgeophysik, Icing Conditions in the
Southern North Sea and Western Baltic,
Part 1, Study No 75 131 Weather Types, May 1975
Part 2, Study No 76 158 Predictors and Spells,
September 1976
- [3] LwA-A3 SAR - Az 56-25 dtd 28 March 78
- [4] LwA-A3 SAR - MSGNR 31981 dtd 3 July 78

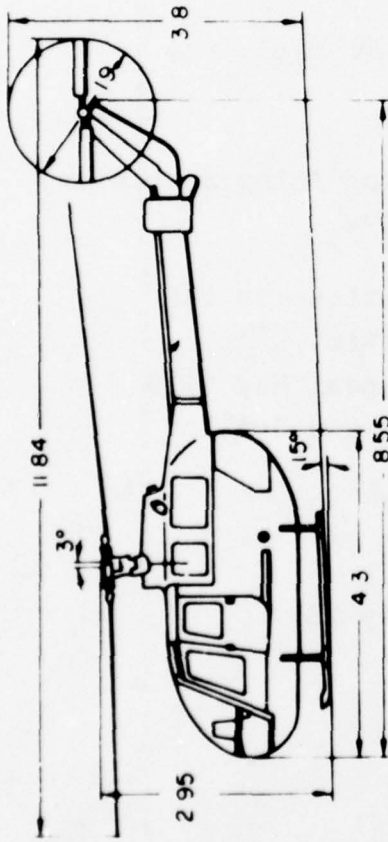

Max Cross Weight = 2300 kg
 Cruise = 250 km/h
 155 m/h
 Engines = 2 Allison 250 C 20

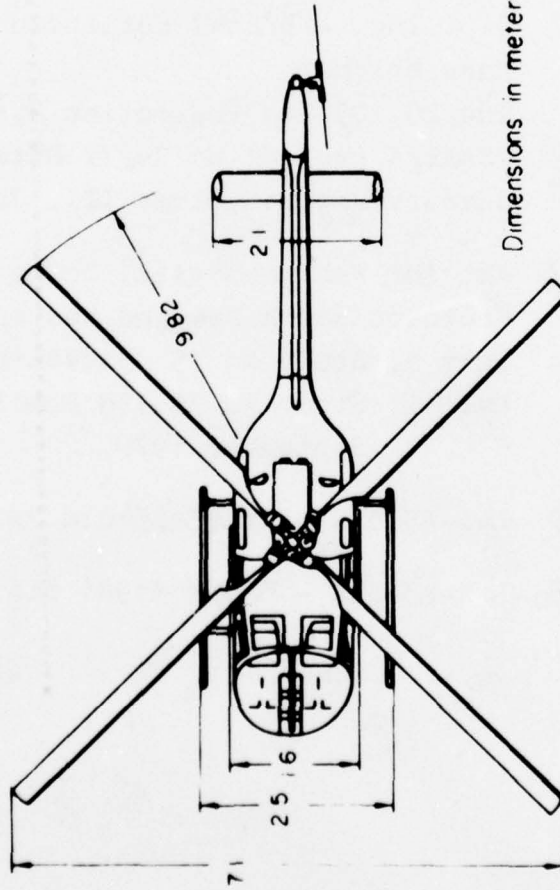

Dimensions in meters

104

BO 105 MAIN DATA

ICING Fig. 1

MBB

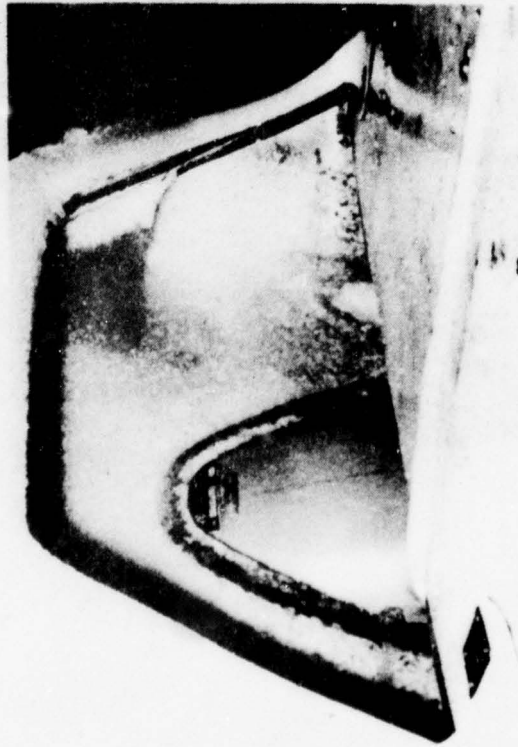
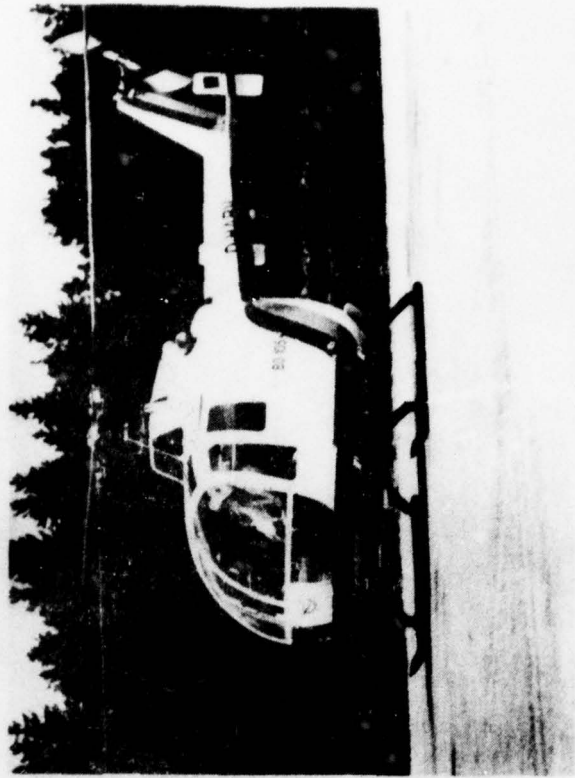

Engine intake protection shield

Icing
Fig. 2



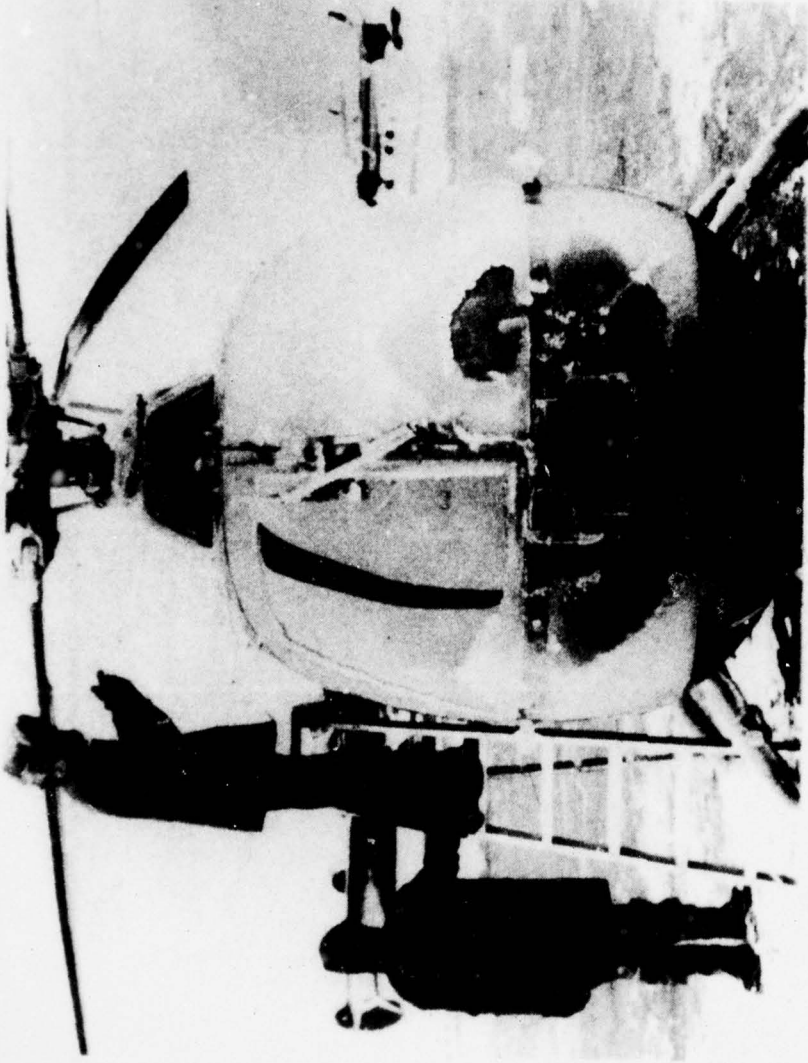

OAT = -7° C LWC = 0 ÷ 0.6 g / m³

Flight No: 135 Flight Time in the cloud 66 Min

Rotor Deicing on

MBB

BO 105 S2

Helicopter, pilot's windshield
electrically heated

NATIL

ICN
Fig 3

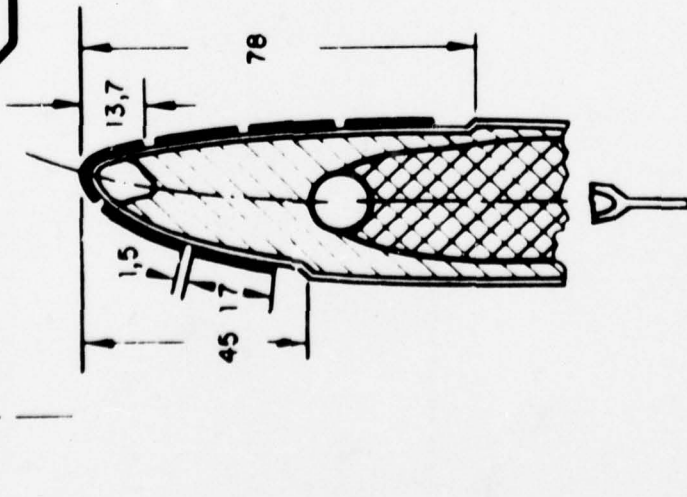
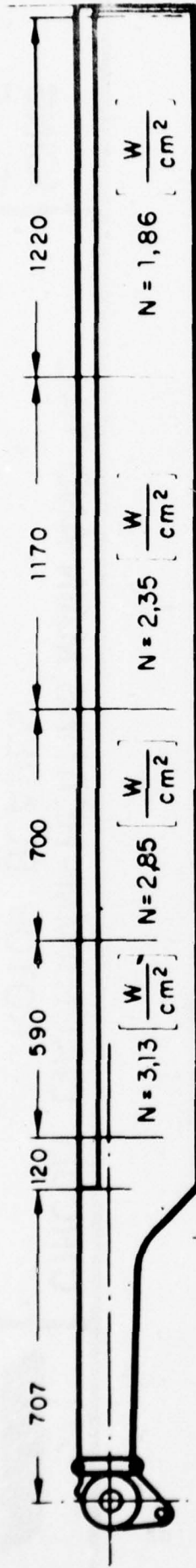

MBB

**POWER DENSITY
POS. OF THE HEATER MATS (MAIN ROT.)**

**ICING
Fig. 4**

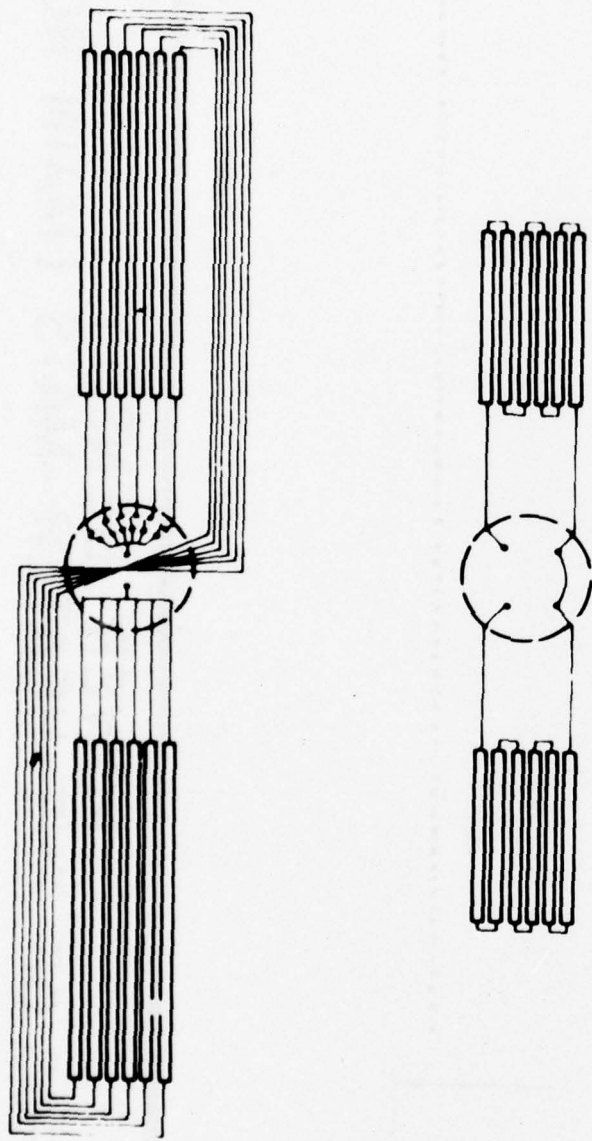

108

**CIRCUIT DIAGRAM - HEATING MAIN AND TAIL
ROTOR BLADES**

MBB

ICING
Fig. 5

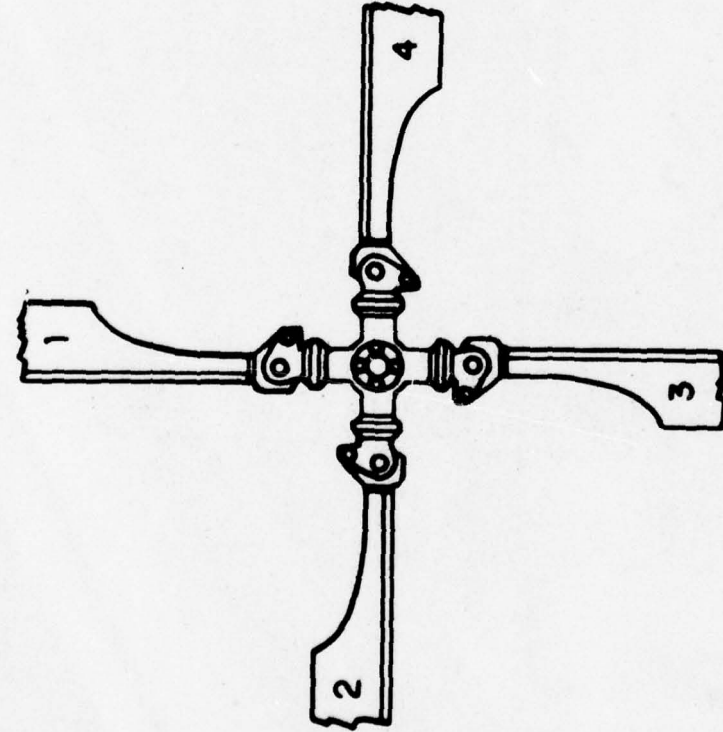
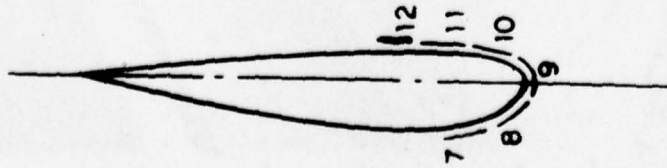

Heating sequence

3, 4, 2, 5 + Tail,

1, 6, 9, 10 + Tail,

8, 11, 7, 12 + Tail

1 Cycle =

12 Heater steps and
Pause

MBB

**HEATING SEQUENCE, HEATER ON TIME,
HEATER OFF TIME**

ICING
Fig. 6

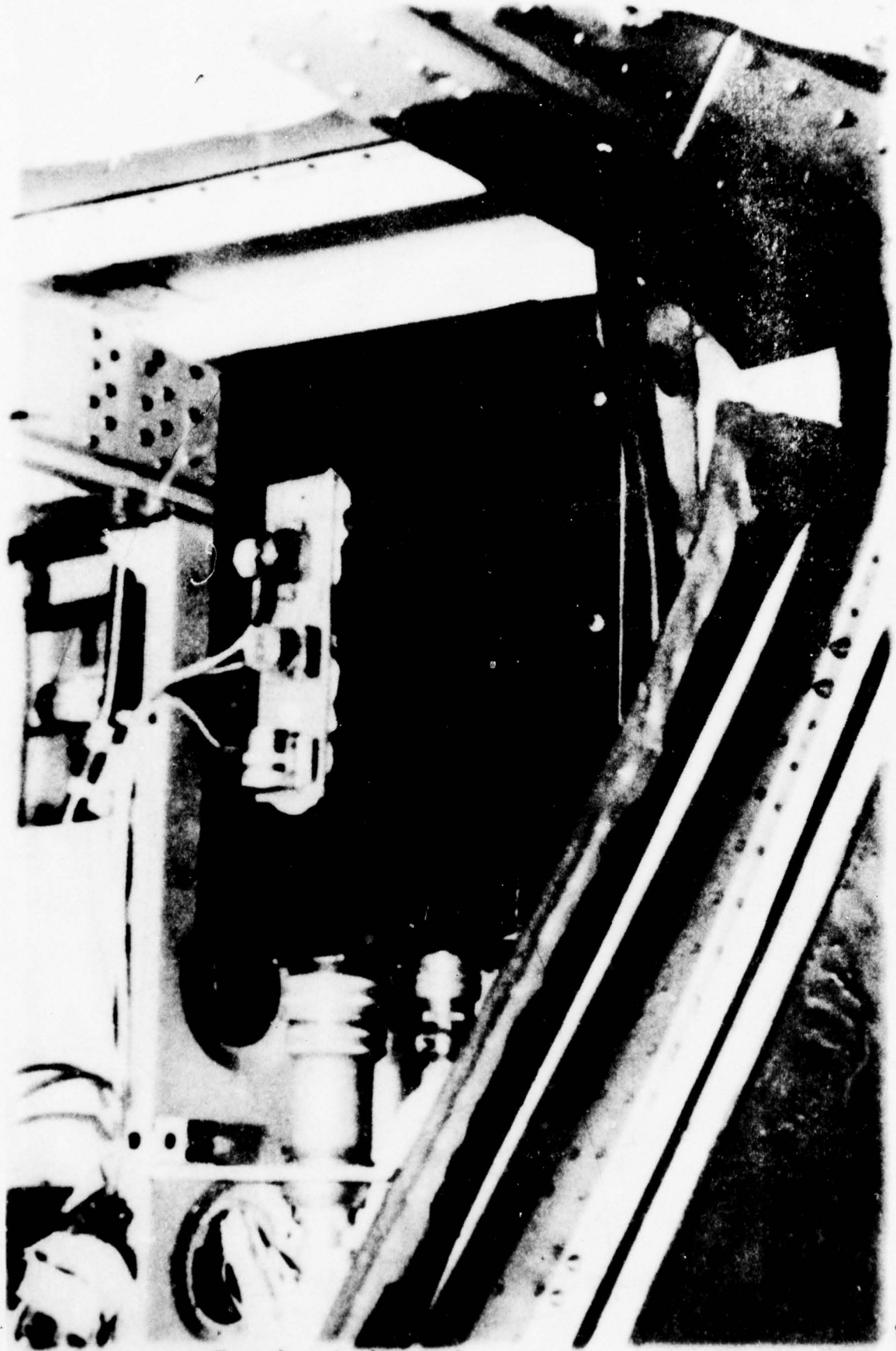

Control Unit

Fig 7

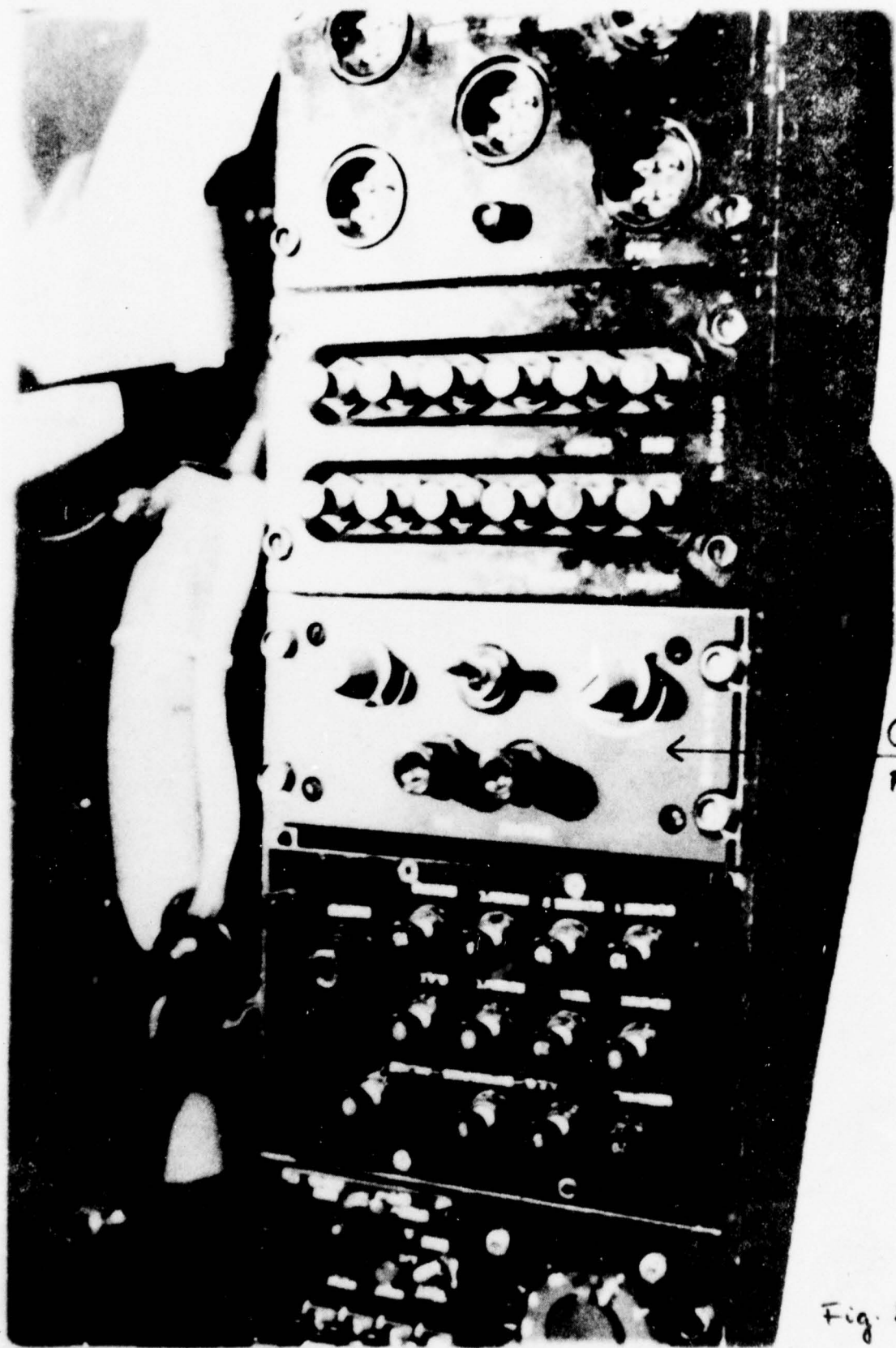

Control-
Panel

Fig. 8

///

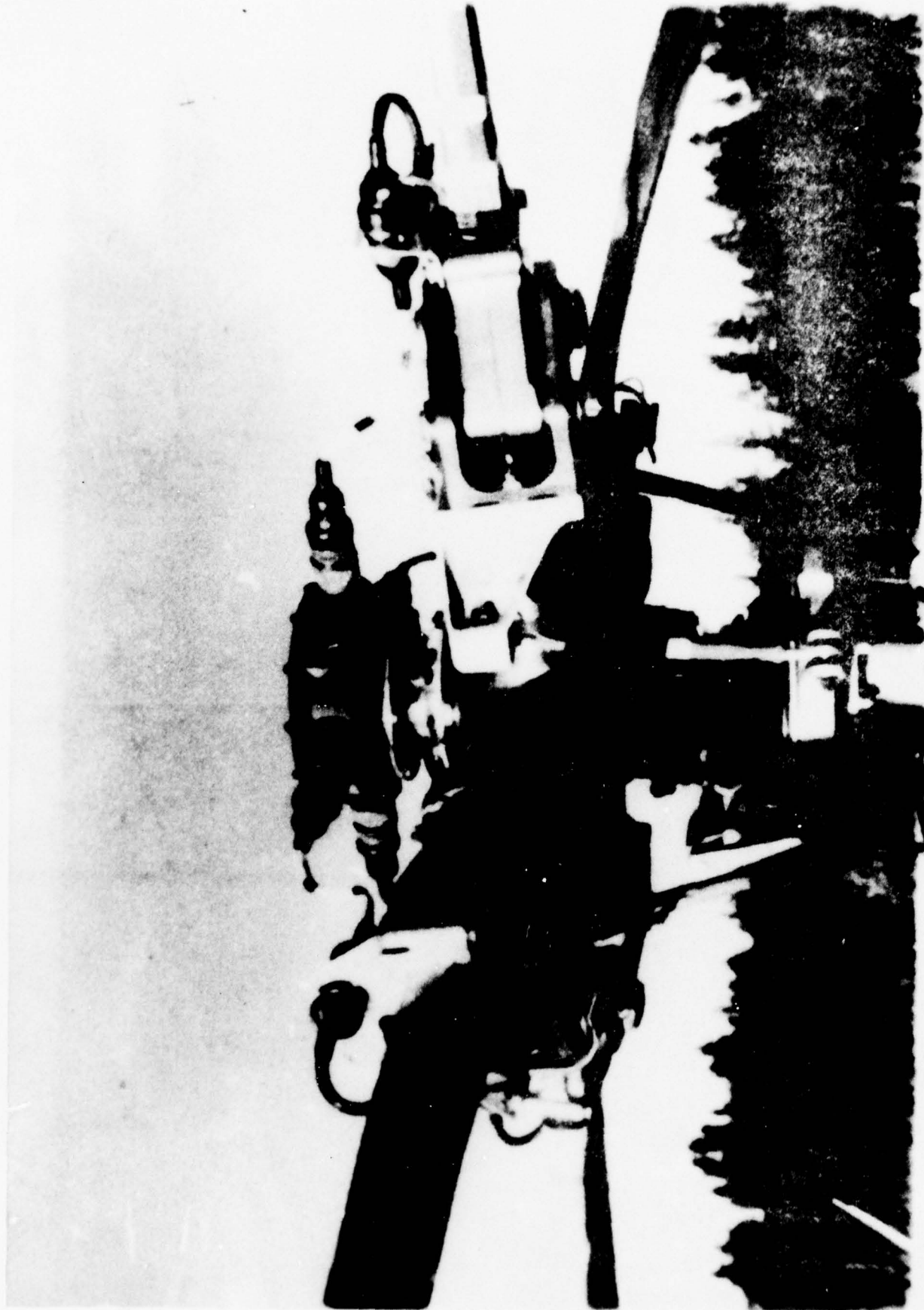

Electronic Stepping Switch

Fig. 9

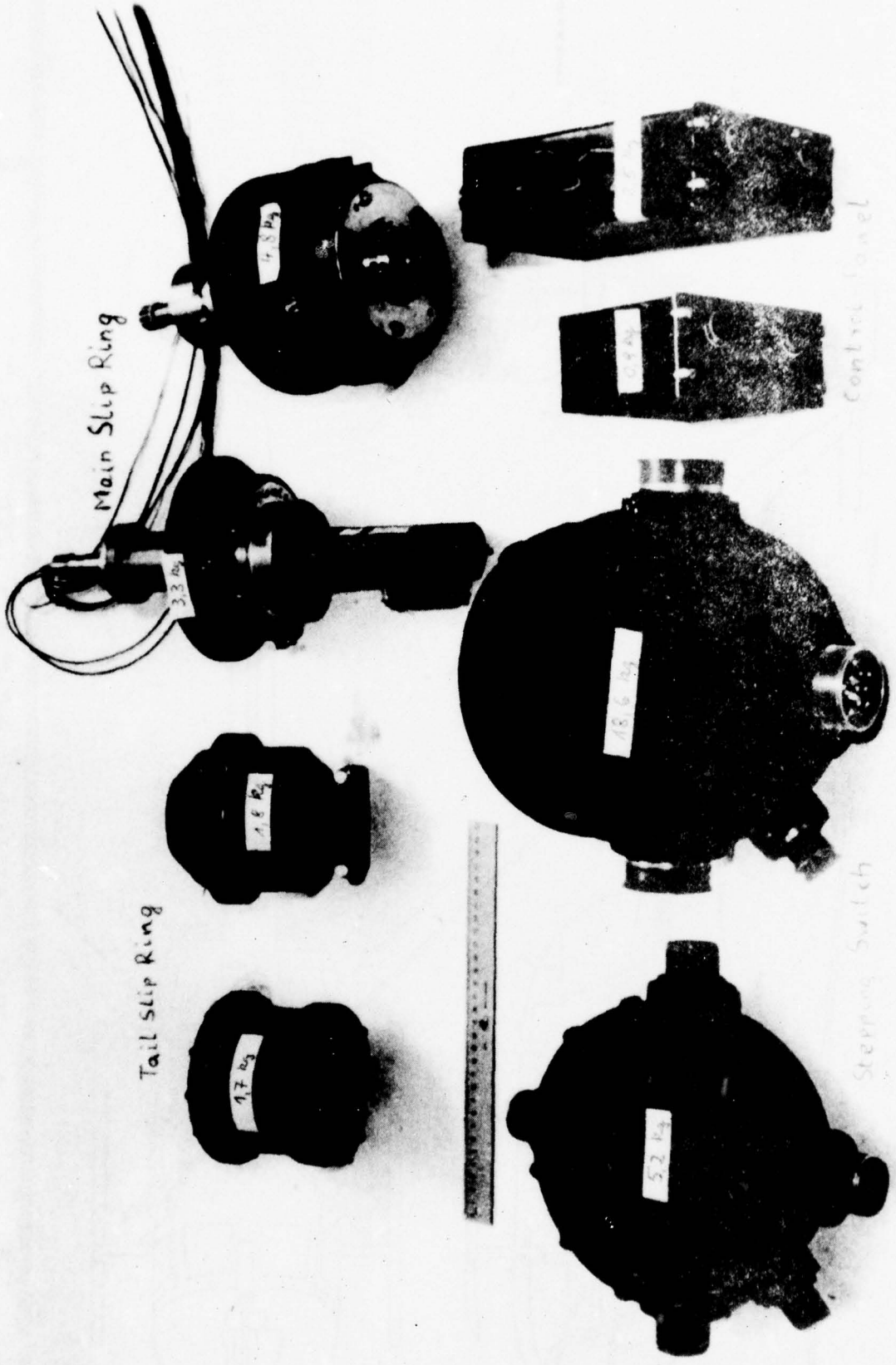

Main Slip Ring

Tail Slip Ring

Control Panel

Stepping Switch

Fig. 10

Two Development Stages of Components

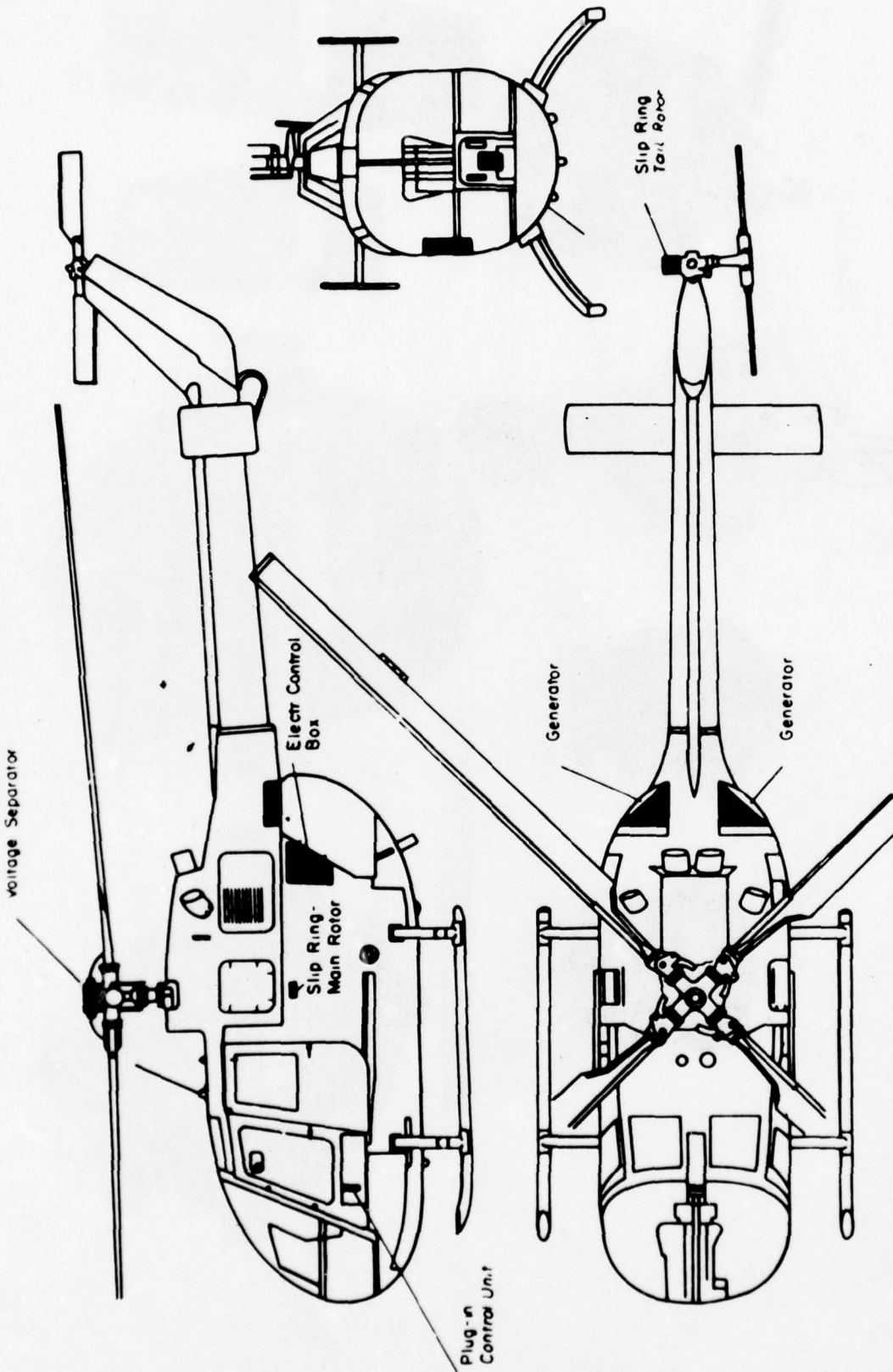

INSTALLATION AREAS OF THE
ROTOR ICE PROTECTION SYSTEM

ICING
Fig. 11



Principle Scheme

Principle Scheme of the Electric Components

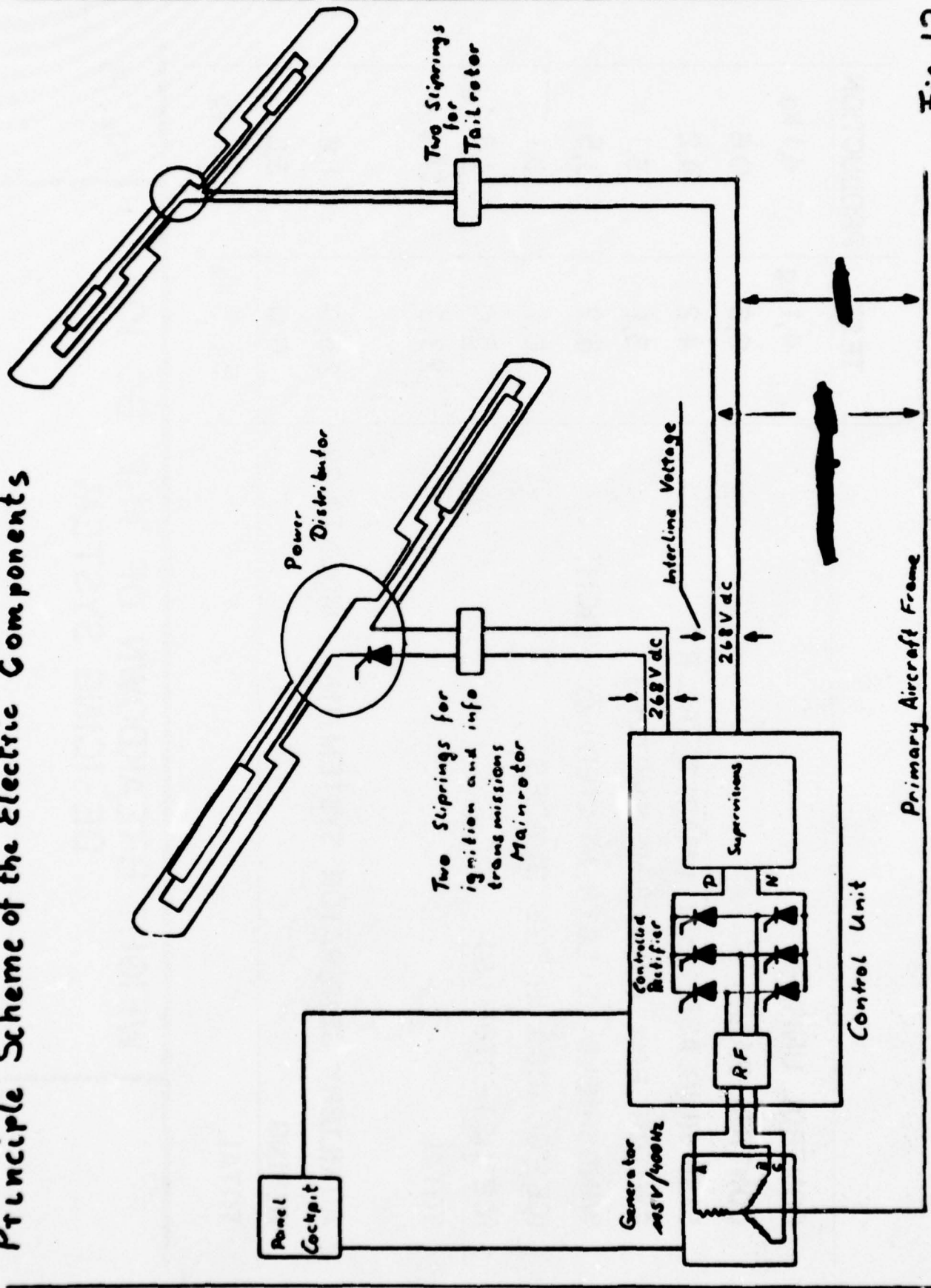

Fig. 12

| | TEST | PRODUCTION |
|--|---------|------------|
| CONTROL UNIT | 4,1 kg | 4,1 kg |
| CONTROL PANEL | 0,6 | 0,6 |
| SLIP RING ASSEMBLY (MAIN & TAIL R.) | 4,2 | 4,2 |
| SWITCH BOX (STEPPING SWITCH) | 3,1 | 3,1 |
| WINDSHIELD (ELECTR. HEATED) Δ WEIGHT | 6,2 | 3,5 |
| ICE - GUARDS IN THE BLADES | 0,1 | 0,1 |
| ICE DETECTOR (S) | 5,0 | 1,8 |
| TOTAL | 23,3 | 17,4 |
| AUXILIARY GENERATOR SYSTEM INCL. MOUNTINGS | 25,0 | 11,6 |
| WIRING | 6,0 | 3,5 |
| TOTAL | 54,3 kg | 32,5 kg |

**WEIGHT BREAKDOWN OF THE BO 105
DE-ICING SYSTEM**

Fig. 13

From January 1974 to 31 May 1978 the following figures were reached:

| | |
|--|---------|
| - number of flights: | 268 |
| - number of test flights: | 108 |
| - overall flight hours, identical to mechanical operation hours of the system: | 166 hrs |
| - electrical operation time of the system during flights: | 25 hrs |
| - number of heating cycles during flights: | 832 |

Fig. 14 Tests with the Rotor Blade De-Icing System on BO 105-S2

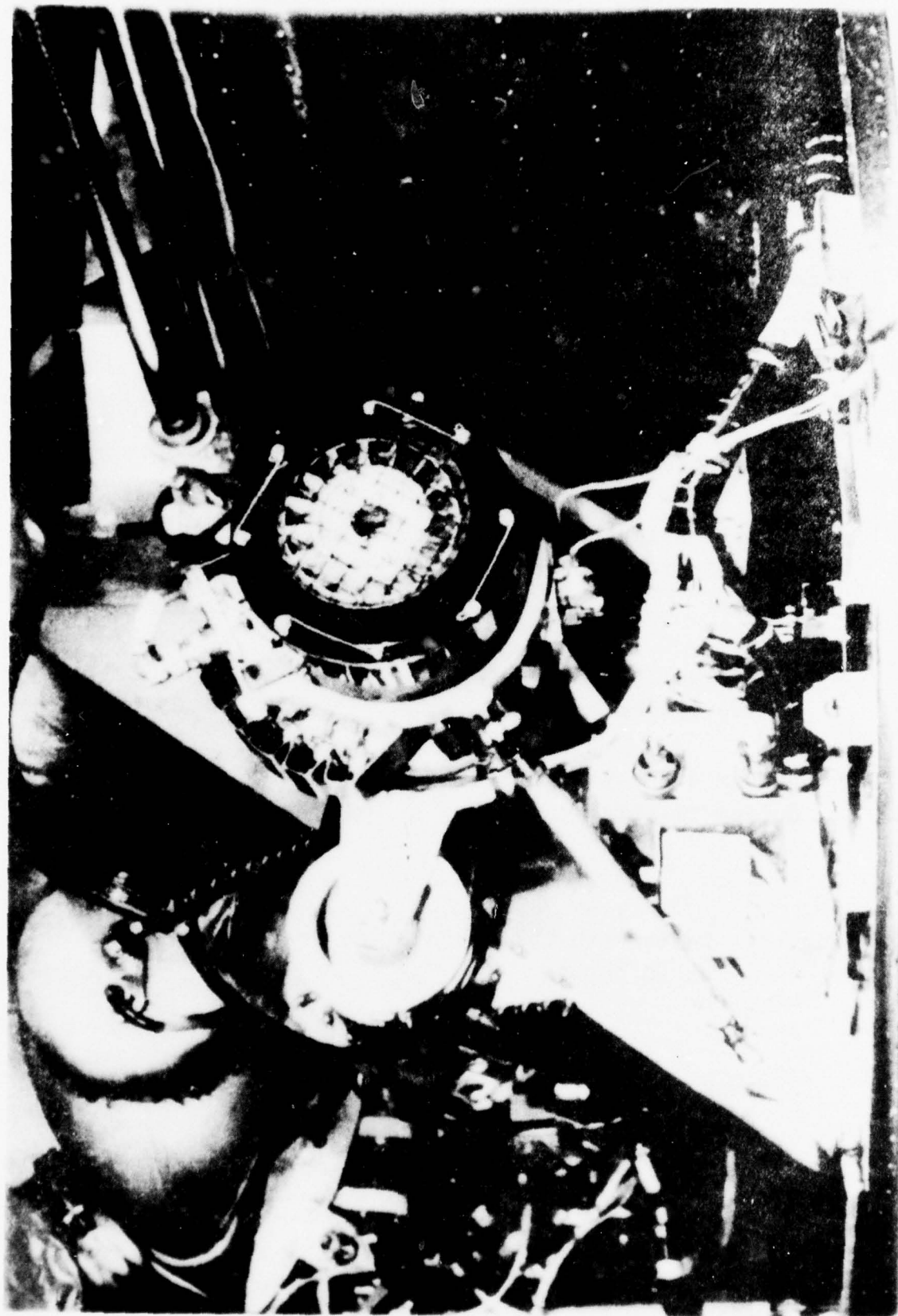

AUXILIARY GENERATOR INSTALLATION

Fig. 15

US ARMY DEVELOPMENTS IN THE AREA OF
HELICOPTER ICE PROTECTION

by

Richard I. Adams
Aerospace Engineer
Applied Technology Laboratory
US Army Research and Technology Laboratories
(AVRADCOM)

Presented to the
Helicopter Icing Symposium
sponsored by
NATO Panel X
at the Royal Aeronautical Society
London, England

6,7 November 1978

US ARMY DEVELOPMENTS IN THE AREA OF HELICOPTER ICE PROTECTION

SUMMARY

Since 1972, the US Army has been involved in performing research to solve the helicopter icing problems and to provide at least a segment of an all-weather air delivery capability. The results of our efforts to date include: revised meteorological design criteria for helicopter ice protection systems; identification of rotor blade ice protection as being the primary area of lagging technology; development of the spanwise shedding, cyclic, electrothermal rotor blade ice protection concept; definition of penalties attendant with helicopter ice protection; acknowledgment that the weight penalties associated with electrothermal rotor blade ice protection are excessive; and initiation of research programs to examine advanced, lighter weight and more cost-effective concepts. The research programs have led to implementation of ice protection systems on the BLACK HAWK, the Advanced Attack Helicopter, and the modernized CH-47, and a partial ice protection for the UH-1H. During the 1978-1979 icing test season, the US Army is planning icing qualification tests of the BLACK HAWK and UH-1H, and icing development tests of the CH-47 ice protection systems, and additional flight tests of promising ice-phobic coatings. In conjunction with these tests, research-related data will be obtained for the benefit of the aviation community in general and to attempt to define the requirements and methodology for icing flight certification of civilian helicopters. This latter portion of the program is being accomplished under an Interagency Agreement between the Federal Aviation Administration and the US Army Aviation Research and Development Command. In addition, the US Army's research and development program has identified other areas of research that must be performed before a sound understanding of the helicopter icing phenomena is achieved and before ice-protected helicopters can be successfully deployed and expected to perform their assigned missions safely and effectively under icing conditions. The need to better understand the phenomena and the effects of mixed conditions, to redefine the icing environment, and to improve forecasting techniques has been identified. Work of this nature is being planned and initiated by NASA, NOAA, the US Air Force Air Weather Service, and the US Air Force Geophysics Laboratory. The US Army has and is continuing to coordinate its programs and findings with other nations of the NATO alliance. This coordination is being performed under the auspices of the Quadripartite Working Group on Army Aviation Equipment and Action Group 3 (HAG 3), Helicopter Icing; Aeronautical Technology, Subgroup H, The Technical Cooperation Program (TTCP).

It appears that the US Army is dedicated to solving the helicopter icing problem since, in the near future, several types of helicopters will be fielded that possess some capability for flight (performance of operational missions) under icing conditions. It is not believed for a moment that there is a full understanding of the icing environment, but it is not possible to wait until that complete understanding exists before we field helicopters with at least a partial capability. It is certain that as operational experience is gained, with these newly fielded helicopters, the

problems associated with helicopter icing will be better defined and refinements will be introduced. This is not considered a problem unique to the US Army, but to NATO as a whole.

INTRODUCTION

The Applied Technology Laboratory (ATL), US Army Research and Technology Laboratories (USARTL) of the US Army Aviation Research and Development Command (AVRADCOM) initiated research and development (R&D) programs in 1972 to establish a technology base for providing Army helicopters the capability of flight in icing conditions. This R&D program was structured to first establish meteorological design criteria to which Army helicopters could be exposed, and then to assure that technology would be available to allow ice protection systems to be developed to meet these criteria. This effort has resulted in the design criteria shown in Figures 1, 2, and 3 for supercooled clouds, freezing rain, and snow conditions. Also, results of technology assessments conducted under this effort basically concluded that design technology was available to meet Army helicopter ice protection needs with the exception of rotor blade ice protection. This initial effort and its results are described in References 1 and 2. Efforts then were concentrated upon selecting and developing an advanced rotor blade ice protection system. Many concepts were considered. These included:

- electrothermal
- bleed air
- heated liquid
- chemical freezing point depressant
- mechanical pneumatic
- ice phobic materials
- electro-impulse
- sonic pulse

Trade-off analyses were conducted to determine the most feasible concepts. Cost, weight, reliability, maintainability, vulnerability, and effectiveness were considered. The concept selected for development was the spanwise shedding, cyclic, electrothermal concept. This concept was developed and applied to the UH-1H helicopter for engineering flight-test purposes. The development and flight-test programs are described in References 3, 4, 5, and 6 and are summarized in Reference 7.

During the development and flight-test program, through coordination with the Army operational community as represented by the US Army Training and Doctrine Command (TRADOC), it was determined that the penalties imposed by the ice protection system were excessive for small, existing helicopters such as the UH-1H and AH-1G and significant for future-generation helicopters such as the Utility Tactical Transport Aircraft Systems (UTTAS) and Advanced Attack Helicopter (AAH). The basis for this conclusion is shown in Tables 1 and 2. Table 1 presents a summary of the penalties imposed upon existing and future-generation helicopters. The ranges shown are for various types and sizes of helicopters. These estimates were made in 1974 based upon use of the spanwise shedding, cyclic, electrothermal rotor blade deicing concept.

Table 1
ESTIMATED PENALTIES OF ELECTROTHERMAL CONCEPT

| | <u>Existing Helicopters</u> | <u>Future Helicopters</u> |
|-----------------|---------------------------------|-------------------------------|
| Empty Weight | 1% - 6% | <1% |
| Power | 40 - 160 SHP | 40 - 160 SHP |
| Range Reduction | 13% - 34% | 13% - 34% |
| Reliability | 0 | 0 |
| Maintainability | 4 MMH/1000 FH | 4 MMH/1000 FH |

Table 2 provides a breakdown of the weight penalty for ice protection of existing helicopters. It is interesting to note that the weight of the ice protection system for the UH-1H is 165 lbs. or 3% of the empty weight. This would require off-loading one troop, or 25% payload, for the four-troop transport mission. The addition of any weight to the AH-1G for any purpose was found to be totally unacceptable. Since 1974, the weight penalty estimates have been revised based upon ice protection system design refinements and changes in helicopter configurations and are included in Table 2. Coordination between the developer and the user is continuing, and it is expected that a common goal for helicopter ice protection will soon be established. In the meantime, TRADOC has recommended additional R&D to develop lighter weight but yet effective rotor blade ice protection concepts.

ALTERNATE METHODS OF ROTOR BLADE ICE PROTECTION

As a result of coordination between the developer and the user and identification of the need for lightweight, effective ice protection for helicopter rotor blades, ATL has initiated efforts to identify other concepts and assess those concepts for feasibility of development. This included reconsideration of the concepts mentioned previously. This effort has resulted in assessments of microwave, vibratory, ice-phobic materials, and the mechanical-pneumatic concepts. Results of the assessments are described in this section. The feasibility of the flexible substrate concept as described by Reference 8 appeared interesting; however, no action was taken by the US Army since the investigations in progress by the United Kingdom were considered totally adequate. Assessment of each of these rotor blade ice protection concepts has included attempts to estimate effectiveness and system characteristics such as weight, cost, reliability, maintainability, durability, and detectability. The following paragraphs summarize the findings of the assessments conducted to date.

Microwave Concept

The microwave concept utilizes the principle of energy transmission by means of radio waves in the microwave frequency range. This utilization is a

Table 2

ESTIMATED ICE PROTECTION SYSTEM WEIGHT - EXISTING HELICOPTERS

| | <u>UH-1</u> | <u>AH-1G</u> | <u>AH-1S</u> | <u>OH-58A</u> | <u>CH-47</u> | <u>CH-54</u> |
|--|-------------|--------------|--------------|---------------|--------------|--------------|
| Main Rotor Increase | 40 | 40 | - | 35 | 0 | 135 |
| Tail Rotor Increase | 0 | 5 | - | 5 | - | 20 |
| Timer/Controller & Stepping Switch | 15 | 15 | - | 15 | 20 | 15 |
| Main Rotor Slip Rings | 10 | 10 | - | 10 | 30 | 15 |
| Tail Rotor Slip Rings | - | 7 | - | 7 | - | 10 |
| Heated Glass Windshield & Controls | 37 | 20 | - | 45 | - | 10 |
| Cockpit Control Panel | 5 | 5 | - | 5 | 5 | 5 |
| Ice Detector & OAT Sensor | 5 | 5 | - | 5 | 5 | 5 |
| Generators & Regulators | -17 | 30 | - | 30 | 60 | 40 |
| Wiring, Relays, Circuit Breakers, Etc. | 70 | 70 | - | 65 | 60 | 40 |
| Engine Air Particle Separator/Inlet | - | 10 | - | 5 | 50 | 50 |
| Rocket Pod Shields | - | 10 | - | - | - | - |
| Miscellaneous Ice Protection | - | 0 | - | 15 | 5 | - |
| IFR Capability | - | 50 | - | 60 | - | - |
| TOTAL (1974 Estimate) | 165 | 277 | - | 302 | 235 | 345 |
| TOTAL (1978 Estimate) | 69 | 136 | 136 | 94 | 210 | - |

common practice today. The microwave oven is a typical example. Microwave energy, when directed to some substances, can be readily and efficiently converted to heat. This is due to the effect of microwave energy upon the molecular activity of certain substances (conductors). Microwave energy is ineffective on other substances (insulators or dielectrics). To be effective and efficient, microwave energy must be properly aimed or directed. This is accomplished by means of waveguides. As reported in Reference 9, much work has been accomplished to prove that certain dielectric materials can be used as surface waveguides with very little energy loss. Therein lies the basic principle of microwave rotor blade ice protection.

Figure 4 presents a schematic diagram of how the microwave concept may be applied to helicopter rotor blades. Microwave energy would be generated by an oscillator capable of producing the power and frequencies in the desired range. This energy is transmitted into a waveguide, a stationary standpipe, constructed of proper materials, shaped and sized for maximum efficiency, to guide the energy to the rotor head. Transition from the stationary standpipe to rotating components can be accomplished by means of a wave choke. The wave choke is a very simple device that by shape alone contains the energy, even though openings exist. After passing through the wave choke, microwave energy can then be directed as necessary to surface waveguides placed in the desired position on the rotor blade. Figure 5 is used to describe the function of the surface waveguide. The microwave energy is transmitted into a dielectric material (waveguide) that is physically attached to the leading edge of the metal or composite material rotor blade. The energy is guided by the dielectric material which is selected for minimum loss. If ice is present on the blade, the ice also becomes a waveguide. Ice, however, is not an efficient transmitter of the microwave energy, and a portion of the energy is converted to heat. As the ice is heated, the adhesion bond is weakened and centrifugal and aerodynamic forces can cause it to be shed.

The above description of the microwave rotor blade ice protection concept is from a layman's point of view. The reader is referred to References 9 and 10 for detailed information. Even though the concept is simple, the design of a microwave deicer is quite complex, and many factors must be considered. One important factor is the crossing of several technology areas, i.e., microwave, materials, and aircraft structural and aerodynamic design.

The assessments of the microwave concept to date have been conducted under contract for ATL by Mr. Bert Magenheim of Mechanics Research Incorporated. The principal results of 2 years of effort are listed in Table 3, which compares the features of the microwave concept to those of the electrothermal concept.

Several areas of concern remain. The studies, assessments, and laboratory demonstrations performed to date indicate that the microwave concept shows promise. Reduced weight, cost, and electrical power requirements are the primary advantages. Reduced detectability when applied to composite rotor blades is also an advantage. However, the surface waveguide must be constructed of a dielectric material. Materials have been identified that are

efficient waveguides and are also fairly erosion resistant, but life would be reduced. Estimates of life are shown by Figure 6.

Table 3

COMPARISON OF THE MICROWAVE CONCEPT TO THE ELECTROTHERMAL CONCEPT

| | |
|------------------|-------------------------------------|
| System Weight | 17% to 36% less |
| Electrical Power | 80% less |
| Cost | 27% less |
| Reliability | about the same (vacuum oscillator) |
| Maintainability | less (higher skill levels required) |
| Detectability | less (dielectric erosion shield) |
| Durability | less (dielectric erosion shield) |

Additionally, microwave generators are not commercially available for the necessary frequency range and power levels. These microwave generators (oscillators) are vacuum tubes that tend to be unreliable, especially in the helicopter induced environment. Some development may be necessary to improve weight, cost, and reliability of oscillators. In addition, we have not demonstrated that the concept can be physically applied to full-scale aircraft hardware. It is estimated that the concept will require 7 to 8 years for development.

The next step planned (but not yet funded) is the application of the concept to full-scale, flight quality hardware for icing tunnel testing. The test article will be a UH-1H or similar tail rotor blade to allow realism to be injected into the system design and to allow exposure to actual dynamic environments. This will allow proof of the concept for adaptability to rotor blades and identification of developmental problem areas.

Research conducted to date has resulted in identification of other possible applications of the microwave concept. The concept may be useful as the basis for an inexpensive, flush-mounted ice detector not susceptible to the Ludlam limit. It may also be applicable to other airframe surfaces, engine inlets, and barrier screens.

Vibratory Concept

The vibratory concept of rotor blade deicing uses blade flexure as a means of inducing ice shedding. It is well known that some blades will self-shed periodically while in flight because of loads imparted to the ice due to natural blade bending, centrifugal force, and aerodynamic forces. It has also been demonstrated that ice will most commonly shed asymmetrically under natural shedding conditions.

Mr. Hugh Upton of Bell Helicopter Textron, under an independent research and development (IR&D) program, performed several laboratory experiments to investigate the feasibility of the vibratory concept to induce ice shedding in a controlled and symmetrical manner. Results of these preliminary laboratory experiments are contained in Reference 11. The US Army became interested in this concept in 1976 and funded an analytical assessment intended to address the basic concerns regarding the concept in addition to determining the system characteristics.

The basic concern was very simply the effect of additional vibration on the life of rotor blades and other airframe and subsystem components since the helicopter vibration environment has already been identified as a significant contributor to poor component reliability, and much R&D has been devoted to reducing the levels of vibration. Results of the assessment conducted by Bell under ATL contract are contained in Reference 12 and are summarized in the following paragraphs.

The assessment considered existing helicopters (UH-1, AH-1, OH-58, and CH-47), future helicopters (UTTAS and AAH), and metal and composite blade construction. Several methods of inducing necessary vibratory loads were identified and are illustrated in Figures 7 and 8. Each of these concepts was analyzed to determine the most suitable. Figure 9 addresses the key issue, i.e., the effect of increased vibratory loads on blade fatigue life. The AH-1G blade is represented in this figure. The normal fatigue life of the AH-1G rotor blade (540 blade) is 1150 hours. If the deicing system were used 10% of the time and the use of dual mode excitation to assure removal of ice from symmetrical mode nodal points on the blade is assumed, the blade fatigue life would be reduced to approximately 650 hours. The weak point of the AH-1G blade is bearing stress of a blade retention bolt hole. It is conceivable that critical areas of the blade could be redesigned to withstand the added loads of the deicing requirements and increase fatigue life. However, it is interesting to note that the mean time to removal of the AH-1G blade is approximately 360 hours (Reference 13), far less than the demonstrated fatigue life.

For composite rotor blades, the story is even more encouraging. The study has concluded that the surface strain necessary for deicing purposes is 300μ in/in. Glass materials normally used in composite blades have a capability of 1500μ in/in strain without fatigue damage. This means that the vibratory concept can be applied to composite blades without reducing the fatigue life of the blade.

Table 4 lists other significant characteristics of the vibratory concept in comparison to the electrothermal concept.

The conclusion drawn from this analytical assessment is that the vibratory concept of rotor blade deicing shows promise and development should be undertaken. Concern remains in certain areas that must be kept in mind during a development program:

- Conclusions are based upon analytical prediction techniques and must be verified by test.

- The analytical assessments were very limited in the area of vibration effects on other airframe components. These effects could vary significantly from one aircraft to another and detailed attention must be given to this area during development, for application to any aircraft, to understand and minimize the effects.
- Complete and symmetrical shedding of rotor blade ice may not be possible. This must be ascertained in full-scale testing. Ice-phobic coatings may assist the vibratory concept.
- Development time is estimated to be 3 to 4 years.

Table 4

COMPARISON OF THE VIBRATORY CONCEPT TO THE ELECTROTHERMAL CONCEPT

| | |
|-----------------|---------------------------|
| Weight | 3% to 28% less |
| Power | 90% less |
| Cost | 29% less |
| Complexity | very simple |
| Adaptability | modifications in kit form |
| Detectability | reduced metallic area |
| Reliability | slightly greater |
| Maintainability | slightly greater |

Development of the vibratory concept of rotor blade ice protection is currently unfunded; however, plans include the modification and instrumentation of a UH-1 or AH-1 helicopter for flight-test purposes. Initial phases of the flight test will be to verify assumptions made for analytical assessment, to establish shaker forces and resultant mode shapes, and to measure blade loads and vibrational amplitudes and frequencies for detailed assessment of the effects on airframe components. Once the system is fine tuned and adequate data has been obtained to assure flight safety, the test aircraft can then be used for icing flight-test purposes. It is envisioned that icing tests would first be conducted in the Ottawa Spray Rig, followed by simulated icing tests behind the Helicopter Icing Spray System (HISS) and then, if necessary, natural icing conditions.

Ice-Phobic Materials Concept

In the area of ice-phobic materials, Reference 14 describes an effort conducted during the late 1960's, jointly by NASA-Lewis Research Center and FAA National Aviation Facility Experiment Center (NAFEC) in which an icing tunnel assessment of over 20 candidate ice-phobic coatings was made. None of the coatings assessed were found to be suitable for aircraft applications, although many were found to reduce adhesion force of ice to the test sample. These tests were conducted in the NASA-Lewis icing tunnel. In 1974, ATL initiated an investigation to determine if other substances might be

available that could reduce adhesion force sufficiently for application to helicopter rotor blades. After a canvas of industry, six substances were selected for laboratory test. Two of the test samples had been tested previously during the NASA-FAA program. These test samples were selected because the adhesion force of the substances was found to be low and correlation between our test technique and the NASA-FAA test technique was needed.

The results of testing conducted for ATL by the US Army Cold Regions Research and Engineering Laboratory, Hanover, New Hampshire, are shown in Figure 10. This figure is extracted from Reference 15. This plot shows the average shear force required to dislodge the ice from the test sample after successive ablation tests. Two coatings repeatedly showed very low adhesion force as can be seen on the left side of the chart. This was true until the test samples were subjected to simulated rain tests, after which the adhesion force increased to the baseline value. These results indicated that, in the supercooled cloud environment, these coatings may have sufficient life to provide rotor blade protection. During the 1977-1978 winter test season, very limited flight-test experiments were conducted to obtain data on the life and application techniques of the coatings. These flight tests were conducted for ATL by USAAEFA in the Spokane, Washington area and were completed in mid-February 1978.

Two coatings were tested: a silicone grease (G-697) manufactured by the GE Silicone Products Division, Waterford, New York, and a cationic silicone oil (E-2460) manufactured by the Dow Chemical Company, Midland, Michigan. Both coatings showed promise, but the life of the Dow substance appeared to be longer. Detailed test procedures and test results are contained in Reference 16.

Table 5 shows that the Dow coating lasted up to 1 hour³ 19 minutes under the test conditions. For comparison purposes, the Army almost lost a UH-1H test aircraft during HISS testing in Alaska in 1974. On that occasion, the UH-1H had been in the cloud (liquid water content (LWC) of 0.25 gm/m³ at -10°C) for 22 minutes when most of the ice on one blade shed asymmetrically, causing very severe vibration and extreme difficulty on the part of the crew to recover and land the aircraft. The Dow coating, under the same test conditions, performed as an ice-phobic coating. With the Dow coating applied to the blade, a mild asymmetric shed was observed after 40 minutes at -10°C and 0.5 gm/m³. At -15°C and 0.25 gm/m³, the torque pressure exceeded the 5 psi limit (imposed for flight-safety reasons) in 13 minutes.

It must be emphasized that these tests were of very limited scope, but the results to date indicate that ice phobics show promise for application to rotor blades and may provide at least a limited capability for flight in supercooled cloud icing conditions where the LWC is less than 0.5 gm/m³ and the ambient temperature is no lower than -10°C. More testing is needed to determine the effects of rain, snow, dust, and other factors on coating performance. A program has been planned for further ice-phobic coating development and for fielding kits for operational evaluation. It is strongly emphasized that ice-phobic coatings are not expected to provide ice protection over the full range of meteorological design criteria.

Table 5

ICE-PHOBIIC COATING FLIGHT-TEST RESULTS

Coating: Dow E-2460

Airspeed: 80 KTAS

| <u>OAT</u> <u>(°C)</u> | <u>LWC</u> <u>(gm/m³)</u> | <u>Cloud Time</u> <u>(Min.)</u> | <u>Remarks</u> |
|---------------------------|---|------------------------------------|------------------------|
| -5 | 0.25 | < 79 | |
| -5 | 0.50 | < 60 | |
| -10 | 0.25 | < 77 | |
| -10 | 0.50 | 40 | mild asymmetric shed |
| -15 | 0.25 | 13 | torque limit (7.0 psi) |

The Mechanical-Pneumatic Concept

During the original assessment of various rotor blade ice protection concepts, Reference 2, the pneumatic concept was rejected for several reasons. The primary concern was material technology that would allow construction of pneumatic boots that could withstand the dynamic environment of the helicopter rotor blade. Since then, the B. F. Goodrich Company has further investigated materials and techniques of pneumatic boot manufacture and has conducted limited testing. Details of the B. F. Goodrich effort are proprietary; however, results in general indicate that it may be possible to develop the pneumatic boot concept for rotor blade ice protection.

A schematic diagram of the pneumatic system applied to a UH-1H helicopter is shown in Figure 11. B. F. Goodrich estimates that the system would weigh approximately 30 pounds (43% of the electrothermal system weight), the system could easily be applied to existing rotor blades, and cost would be much less than that for the electrothermal concept. Many questions must be answered before this concept can again be considered viable; however, based upon limited testing conducted to date by B. F. Goodrich, further investigation is considered appropriate.

APPLICATION OF ICE PROTECTION TO ARMY HELICOPTERS

As in any R&D program, it is best to conduct the program so that positive results can be applied directly. This was one of the underlying reasons for selecting the UH-1H as the test bed helicopter for the ATL research flight-test program. The ATL research test helicopter is depicted in Figure 12. It contains anti-iced glass pilot and copilot windshields; a modified FM whip antenna; ice-protected main and tail rotor blades and main rotor stabilizer bar; a 20/30 KVA, 3-phase, AC electrical system to power the ice protection system; and a flight-test instrumentation system. The instrumentation system includes cockpit displays of cloud liquid water content (LWC) and ambient temperature (OAT) and a unique integrating rate unit that integrates LWC as a function of time.

The UH-1H Partial Ice Protection System

In 1975, the UH-1 Readiness Project Officer (RPO) submitted a product improvement proposal for incorporation of two kits. Kit A includes anti-iced windshields, icing severity level indication system (cockpit display of LWC and OAT), modified FM whip antenna, and the AC electrical system. Kit B (not yet approved) includes main and tail rotor system ice protection. Kit A, referred to as the UH-1H partial ice protection system, was approved in calendar year 1976 and funding was made available in fiscal year 78 for development and qualification. Bell Helicopter Textron is now under contract to design and qualify Kit A. Flight tests for Kit A icing flight qualification are scheduled to be conducted during the 1978-1979 winter season.

Benefits of the UH-1H Partial Ice Protection System

The UH-1H is currently authorized to fly in forecast light icing conditions although the operator's manual recommends against such flight. Flight in moderate or severe icing conditions is prohibited. Ice protection of the UH-1H now includes engine and Pitot tube anti-icing. This authorization is considered unsafe because of the following rationale:

- Missions are deployed or cancelled based upon the weather forecast.
- Icing forecasts are commonly inaccurate. The icing condition can be more or less severe than forecast.
- Light icing forecasts relate the effects on fixed-wing aircraft and can be issued when ambient temperature is at any level below freezing.
- The flight crew has no way of determining the severity of icing.
- Flight testing conducted to date indicates that the UH-1H, without rotor blade ice protection, may be flown for some period of time under icing conditions (LWC less than approximately 0.50 gm/m^3) if ambient temperature is greater than approximately -5°C . Further testing to establish these limits is planned.
- Operational and flight testing experiences conclude that the VHF-FM whip antenna is very commonly severed by the tail rotor blades when the UH-1H is flown in icing conditions.
- Operational and flight testing experiences conclude that forward visibility is destroyed under any icing condition.

The concept of Kit A is to reduce the hazard of flight in icing conditions by the following:

- Providing forward visibility.
- Preventing the FM whip antenna from contacting the tail rotor.

- Providing the flight crew with in-flight quantification of the icing severity level so that they can use the forecast for planning purposes only.
- Providing the flight crew with quantified capabilities and limitations of the Kit A equipped UH-1H and operational procedures.

With Kit A, revised operator's manuals, and adequate training, the flight crew can use the weather forecast for planning purposes but regardless of the icing forecast, missions can be deployed. During the mission, the crew can monitor the icing severity level, continue the mission if conditions warrant, take evasive action if necessary, or abort the mission. Under the assumption that mission availability of the UH-1H is currently virtually zero when icing conditions are forecast, Kit A is expected to increase mission availability by a factor somewhat greater than 50%. This is based upon natural icing test experience that indicates that forecast icing conditions are actually encountered only about 50% of the time. In addition, Kit A will allow mission completion under many icing conditions that are encountered.

Kit A will also provide increased safety during inadvertent encounter of nonforecast icing conditions which is a fairly common occurrence. Without proper training for flight in icing conditions, the uncertainties induced by the inadvertent icing encounter can be quite disconcerting to the crew especially when forward visibility is lost. With Kit A installed and the accompanying training, the inadvertent encounter will not be as disconcerting to the crew since forward visibility will be retained and the severity of the icing condition will be known. Under this condition, depending upon specific circumstances, the crew can take necessary action to continue the mission or evade the condition and report, in quantified terms, the severity of the icing condition encountered.

The foregoing discussion described the benefits of a partially ice-protected helicopter in relation to an essentially unprotected helicopter. It is the author's opinion that the only safe approach is for helicopters to be equipped with complete ice protection equipment that is designed to provide protection for any condition that can be encountered and is properly proven or certified. At the same time, however, the realities of funding limitations, allowable mission trade-offs, and the fact that the calculated risk becomes essential to take maximum advantage of available equipment and resources must be recognized.

Research Objectives

The UH-1H flight-test program for Kit A qualification will use the Applied Technology Laboratory's test bed helicopter, modified to incorporate productionized Kit A hardware. The main rotor and tail rotor ice protection system will remain intact to lend safety to the Kit A qualification program during natural icing test flights to determine the capabilities and limitations of the Kit A equipped UH-1H helicopter. In addition, as pointed out by Mr. Cotton of the Lockheed-California Company in Reference 6, the research

flying performed to date has not covered the full range of design criteria. From a research standpoint, we intend to continue to expand the icing severity level envelope as far as possible and as available weather conditions permit. Within the constraints of safety considerations and weather conditions, we also plan to continue probing freezing rain, snow, and mixed conditions.

The FAA/AVRADCOM Interagency Agreement

Over the past few years, coordination between the Federal Aviation Administration (FAA) and ATL has continued. FAA personnel have been interested in the ATL helicopter icing research program since the results could apply to civil helicopters. FAA engineering test pilots participated in the ATL icing research flight-test program during the 1976-1977 and 1977-1978 winter test seasons.

The FAA interests and urgency are based primarily upon the knowledge that civil helicopter operators now desire a near all-weather capability. This desire has been stimulated by the off-shore exploration and drilling operations that are being supported and are forecast to be heavily supported in the future by the helicopter.

The FAA objectives, therefore, are to acquire sufficient data to form a basis for determination of changes needed to the Federal Aviation Regulations (FAR) relating to helicopter ice protection system design criteria, icing certification requirements and methodology, and operational requirements and methodology.

The FAA and AVRADCOM, therefore, have entered an agreement whereby the FAA will participate financially in the UH-1H partial ice protection system qualification flight-test program. In combination with the ATL participation, the FAA participation will allow expansion of the 1978-1979 winter test season from 1 month to approximately 3 months, allowing a much greater probability of successful qualification of the UH-1H partial ice protection system, as well as attainment of Army and FAA R&D goals.

BLACK HAWK Ice Protection System

The US Army's desire to have a near all-weather air delivery capability has led to a contractual requirement for the BLACK HAWK (the Utility Tactical Transport or UH-1 replacement) to be capable of flight in moderate icing conditions.

Salient features of the BLACK HAWK are pointed out in Figure 13. Windshields, engines and engine inlets, Pitot-static tubes and struts, main rotor blades, and tail rotor blades are provided ice protection.

The rotor blade ice protection concept selected by Sikorsky Helicopter Company is the conventional spanwise heating for chordwise shedding, electrothermal concept. The heating elements are divided into 4 spanwise zones and protect 12% of the chord on the upper surface and 17% of the chord

on the lower surface. The spanwise zones are heated sequentially. Respective zones on two opposing blades are sequenced simultaneously. Power density is constant along the span and is 25 watts/in². The heater mats used are the woven wire concept manufactured by the Goodyear Aerospace Corporation.

Tail rotor protection is similar to that of the main rotor. Power density is 10 watts/in², and chordwise coverage is 12% on each side.

The engines and engine inlets are anti-iced using engine bleed air.

Windshields are electrically anti-iced. The center windshield is not ice-protected.

The BLACK HAWK rotor blade ice protection system is designed to meet a portion of the design criteria presented in Figure 1, and is expected to be capable of continuous flight in icing conditions if liquid water content does not exceed 1.0 gm/m³. Above this severity level, the system will saturate based upon an ice shed thickness of 0.25 inch.

The rotor blade ice protection system is automatically sequenced, once armed by the pilot, as a function of ambient temperature and liquid water content. In addition, these parameters (OAT and LWC) are displayed in the cockpit for crew information.

Advanced Attack Helicopter Ice Protection

The AAH ice protection features are depicted in Figure 14. Ice-protected components include main and tail rotor blades, engines and engine inlets, windshield and forward panel of the overhead canopy, target designation systems (TADS), pilot night vision system (PNVS), rocket systems, and Pitot-static tubes. The AAH will be equipped for automatic control of the main and tail rotor deicing system once the system is armed by the pilot. All other components are anti-iced. Engines are protected by a bleed air anti-icing system, while engine inlet protection uses a combination of bleed air and electrothermal anti-icing.

Main rotor blade deicing heater blankets consist of etched foil heating elements placed inside the leading edge skin. The heater blankets are manufactured by Sierracin Thermal Systems. Heating elements are divided into five spanwise zones that are energized sequentially on opposing blades simultaneously. Design provisions allow chordwise coverage of approximately 10% on the upper surface and 26% on the lower surface. Power density for main rotor deicing is graded from approximately 11 watts/in² at the tip to 25 watts/in² near the blade root.

Construction of the tail rotor deicing blankets is very similar to that of the main rotor; however, the entire blanket in each of the four tail rotor blades is energized simultaneously following the energy-on sequence of the last zone of the main rotor blade.

AD-A067 981

MINISTRY OF DEFENCE LONDON (ENGLAND)
HELICOPTER ICING SYMPOSIUM, 6-7 NOVEMBER 1978, LONDON, (U)
NOV 78 T C DON

F/6 1/3

UNCLASSIFIED

NL

4 OF 4

AD
A067981



| | | | | | | | | | | | | | | |
|--|--|--|--|--|--|--|--|--|--|--|--|--|--|--|
| | | | | | | | | | | | | | | |
| | | | | | | | | | | | | | | |
| | | <p>END DATE FILMED 6 -79 DDC</p> | | | | | | | | | | | | |

The AAH is also equipped with cockpit display of cloud liquid water content and ambient temperature.

The AAH ice protection system is designed for the "moderate" icing condition and will be capable of continuous operation in severity levels up to approximately 1.0 gm/m^3 .

CONCLUSIONS

The Applied Technology Laboratory has investigated helicopter ice protection technology for the past 5 years. During these investigations, it has been concluded that the rotor blade presents the biggest challenge in providing the helicopter a capability for flight in icing conditions. Through these efforts the spanwise shedding, cyclic, electrothermal deicing concept has been developed and this technology placed on the shelf for use as applicable. Through coordination with operational elements of the US Army, the fact that the penalty of electrothermal rotor blade ice protection, primarily weight, is excessive has been identified. R&D efforts have been initiated to identify and develop other concepts of rotor blade ice protection that are light-weight and cost effective.

The microwave and vibratory concepts of rotor blade ice protection show promise and R&D programs have been planned for development of these concepts. These R&D programs remain unfunded through FY80. Discussions are being held with representatives of NASA to consider joint development of the microwave concept for application to military and civilian helicopter rotor blades as well as application of the concept to other components and uses such as engine intakes and ice detectors.

Plans to be implemented during the 1978-1979 winter test season include qualification of the UH-1H partial ice protection system and the BLACK HAWK ice protection system. Development testing of the CH-47 ice protection system is also planned, as well as testing to better understand/define the life of promising ice-phobic coatings. Work is in progress in coordination with the FAA to establish helicopter ice protection design and certification requirements and methodology.

This work has contributed to the identification of the following other areas of technology that need further work:

- Verification and international standardization of icing meteorological criteria.
- An understanding of the mixed icing condition environment and its effects.
- The need for better icing simulation facilities for R&D and certification purposes.
- The need for improved icing forecasts.

- The need for quantifiable icing terminology and international standardization of this terminology.
- The need for a helicopter ice protection system design guide.

The US Army appears dedicated to the resolution of the helicopter icing problem, but the funding resources required for completion of this task are astronomical. Other nations of the NATO alliance also are dedicated to resolve the problem and we will all benefit from its resolution. A well-organized, well-planned NATO supported program for timely and cost effective resolution of the helicopter icing problem is highly recommended.

REFERENCES

1. Werner, J. B., "Ice Protection Investigation for Advanced Rotary-Wing Aircraft," USAAMRDL-TR-73-38, August 1973, AD 771182.
2. Werner, J. B., "The Development of an Advanced Anti-Icing/Deicing Capability for US Army Helicopters, Volume I - Design Criteria and Technology Considerations," USAAMRDL-TR-75-34A, November 1975, AD A019044.
3. Werner, J. B., "The Development of an Advanced Anti-Icing/Deicing Capability for US Army Helicopters, Volume II - Ice Protection System Application to the UH-1H Helicopter," USAAMRDL-TR-75-34B, November 1975, AD 019049.
4. Cotton, R. H., "Ottawa Spray Rig Tests of an Ice Protection System Applied to the UH-1H Helicopter," USAAMRDL-TR-76-32, November 1976, AD A034458.
5. Cotton, R. H., "Natural Icing Flight Tests and Additional Simulated Icing Tests of a UH-1H Helicopter Incorporating an Electrothermal Ice Protection System," USAAMRDL-TR-77-36, July 1978.
6. Cotton, R. H., "Icing Tests of a UH-1H Helicopter with an Electrothermal Ice Protection System under Simulated and Natural Icing Conditions," USARTL-TR-78-48, to be published approximately December 1978.
7. Kitchens, P. F. and Adams, R. I., "Simulated and Natural Icing Tests of an Ice-Protected UH-1H," pre-print 77.33-25, presented at the 33rd Annual National Forum of the American Helicopter Society, May 1977.
8. Sewell, J. H., "The Design and Development of New Ice-Shedding Coatings," Rotary Wing Icing Symposium, Summary Report Volume II, USAAEFA Project No. 74-77, 4-6 June 1974.
9. Magenheim, Bertram and Hains, Frank, "Feasibility Analysis for a Microwave Deicer for Helicopter Rotor Blades," USAAMRDL-TR-76-18, May 1977.
10. Magenheim, Bertram, "Demonstration of the Microwave Ice Protection Concept," USAAMRDL-TR-77-34, May 1978.
11. Upton, H. W., "Mechanical Deicing Concept for Helicopter Rotor Blades," presented to the Staying Power Symposium, Fort Rucker, Alabama, 8-10 July 1975.
12. Lemont, H. E. and Upton, H. W., "Vibratory Ice Protection for Helicopter Rotor Blades," USAAMRDL-TR-77-29, June 1978.

13. Clark, M. W., Krauss, W. K., and Ciccotti, J. M., "Identification and Analysis of Army Helicopter Reliability and Maintainability Problems and Deficiencies, Volume II - Utility, Attack and Training Helicopters (UH-1, AH-1 and TH-1)," USAAMRDL-TR-72-11B, April 1972.
14. Miller, D. M., "Investigation of Ice Accretion Characteristics of Hydro-Phobic Materials," FAA-DS-70-11, Federal Aviation Administration, National Aviation Facilities Experimental Center, Atlantic City, New Jersey, May 1970.
15. Artis, Donald R., Jr., "Ice Phobic Coatings for Army Rotary Wing Aircraft," USAAMRDL Technical Note 19, May 1975.
16. Tulloch, John S., CW4; Doten, Frederick S., MAJ; Smith, Raymond B.; and Bishop, John A., CW4; "Artificial Icing Tests, Ice-Phobic Coatings on UH-1H Helicopter Rotor Blades," USAAEFA Project No. 77-30, June 1978.

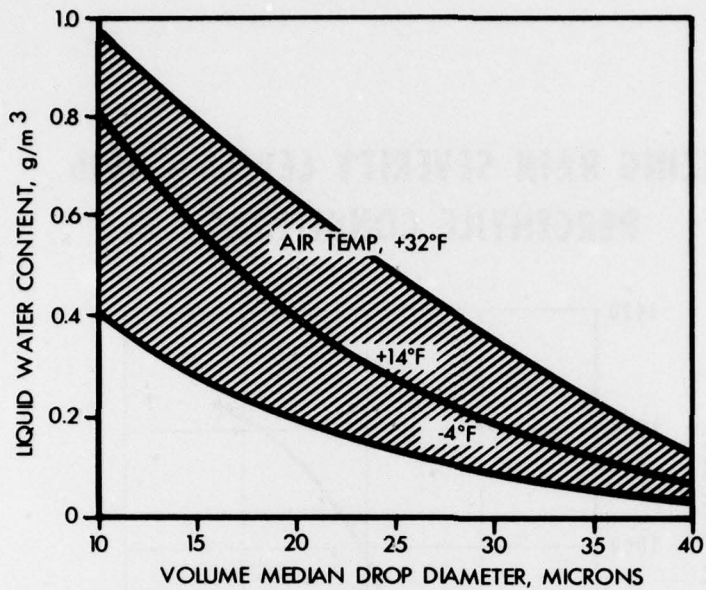

(A) CONTINUOUS MAXIMUM (STRATIFORM CLOUDS)

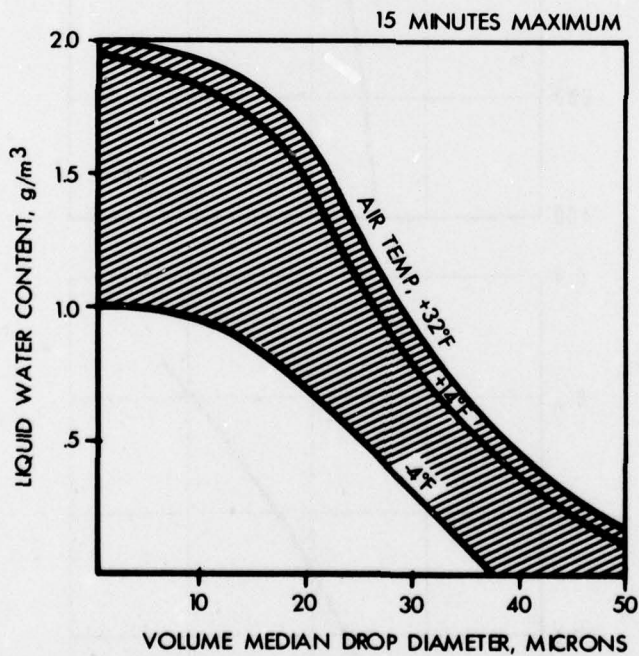

(B) INTERMITTENT MAXIMUM (CUMULIFORM CLOUDS)

Figure 1. RECOMMENDED ATMOSPHERIC ICING CRITERION

FREEZING RAIN SEVERITY LEVELS - 99th PERCENTILE CONDITIONS

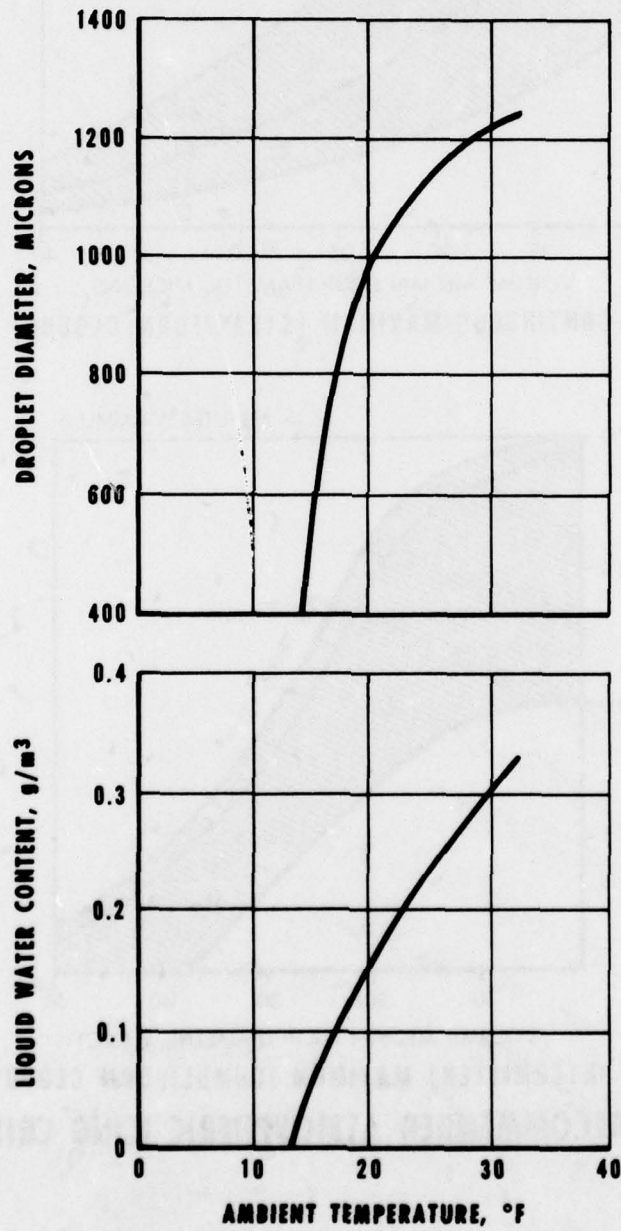

Figure 2

**WORLDWIDE MAXIMUM SNOWFALL LIQUID WATER CRITERIA -
99th PERCENTILE CONDITIONS.**

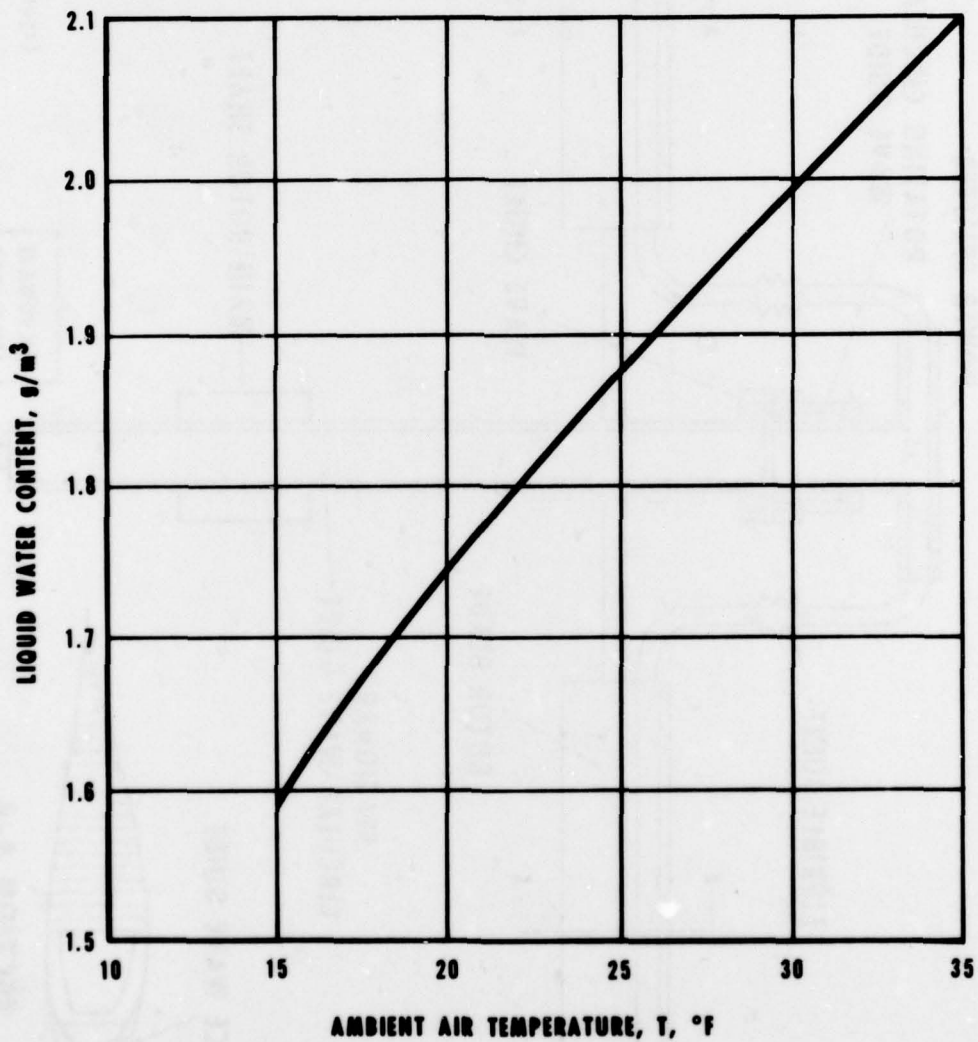

Figure 3

MICROWAVE DEICER ROTOR BLADE CONCEPT

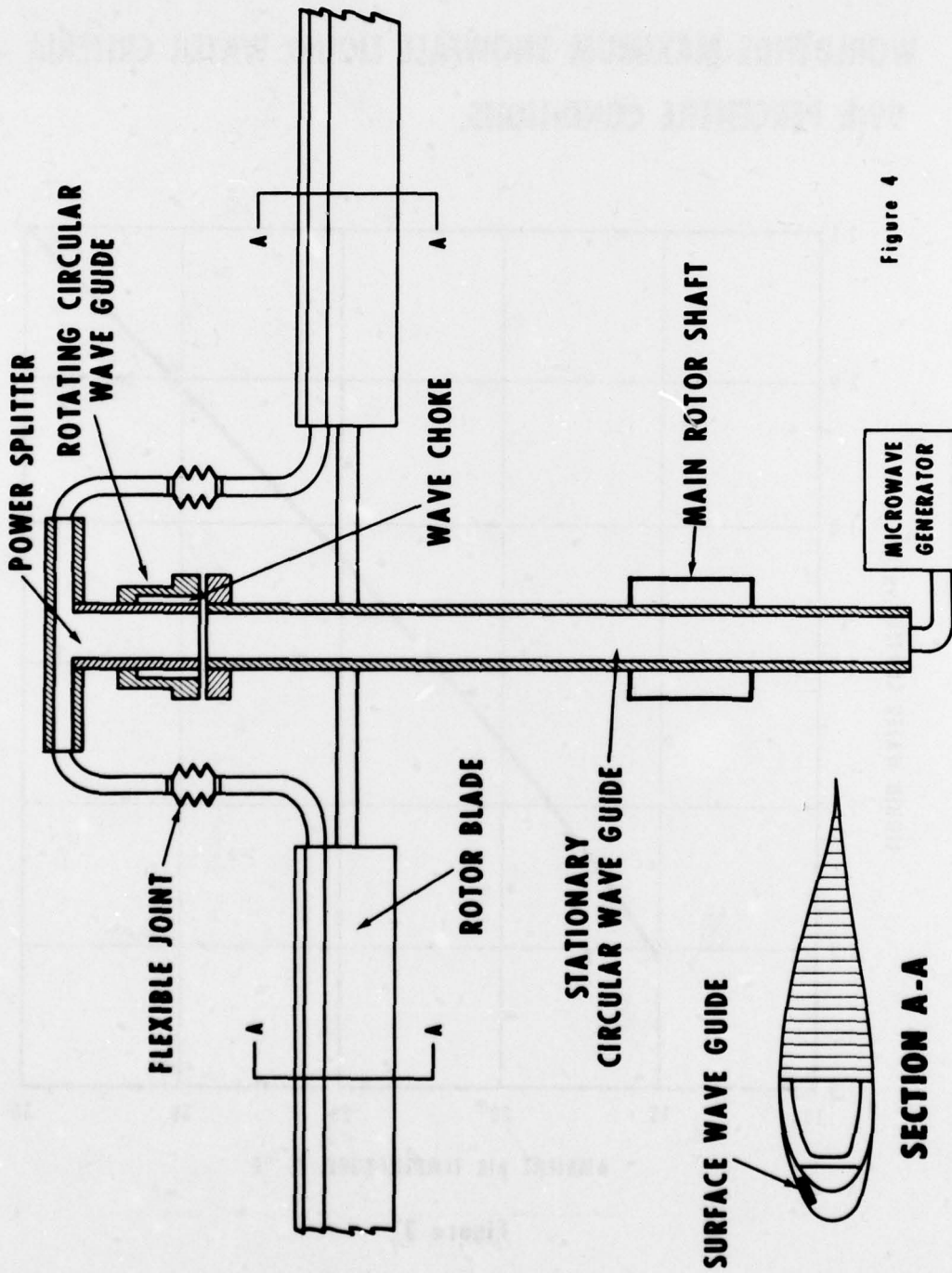

Figure 4

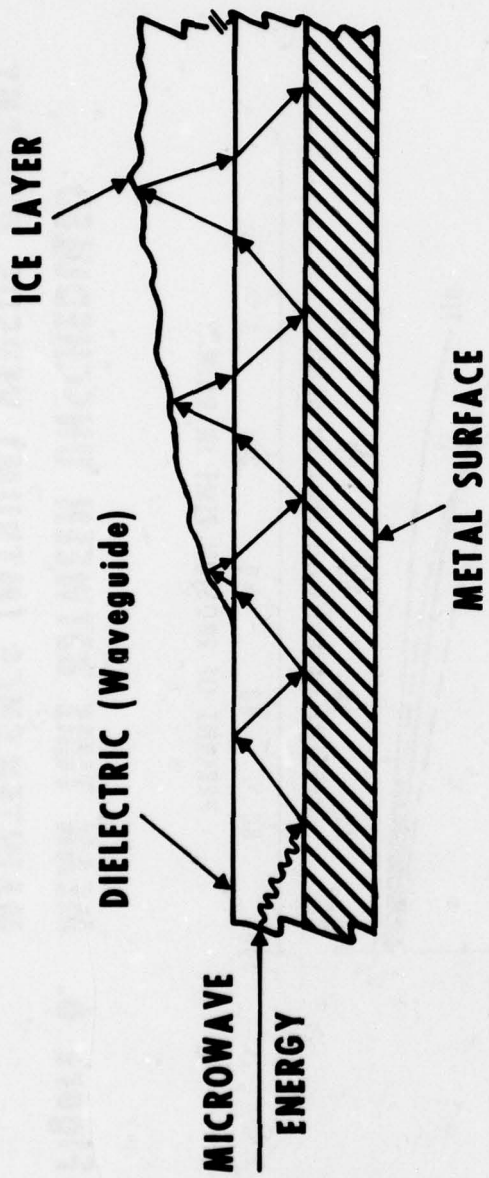

Figure 5. GUIDANCE OF MICROWAVE ENERGY BY COMPOSITE ICE-DIELECTRIC SURFACE WAVEGUIDE

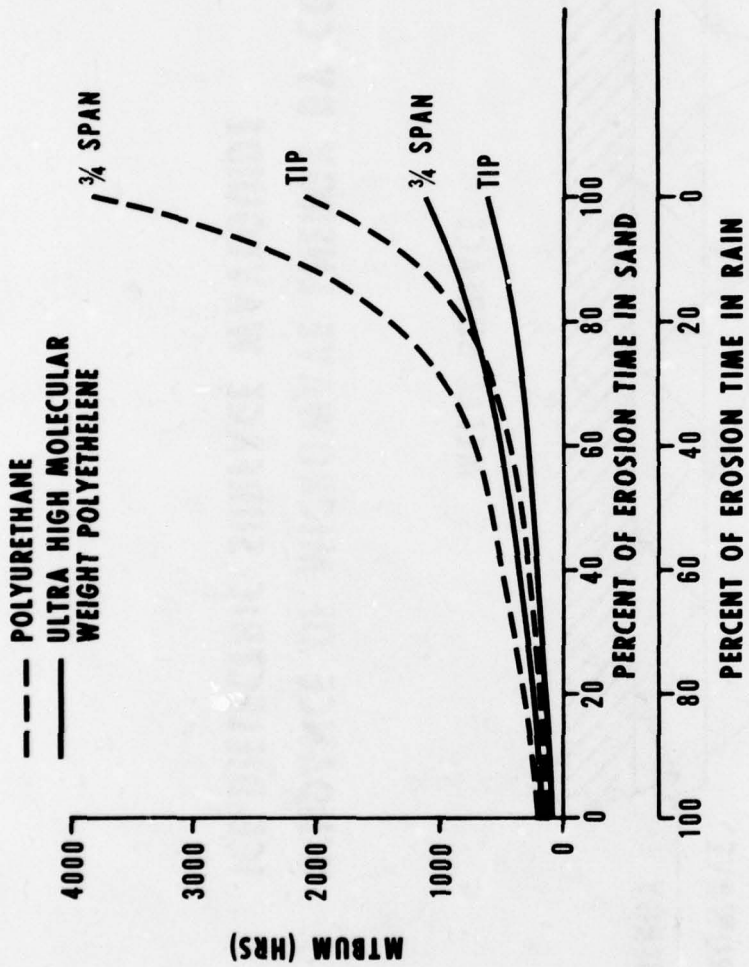
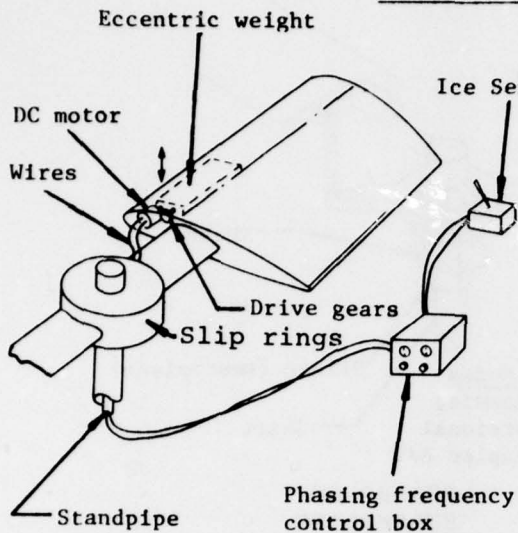
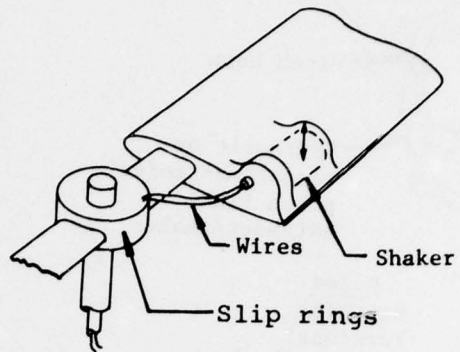

Figure 6. MEAN TIME BETWEEN UNSCHEDULED MAINTENANCE (MTBUM) VERSUS PERCENT EXPOSURE TO SAND & RAIN EROSION

BLADE-MOUNTED SHAKERS



Mode
Beamwise
SHAKER IN SPAR



Modes
Beamwise
Torsional
Coupled B/T
SHAKER AFT OF SPAR

HUB-MOUNTED SHAKERS

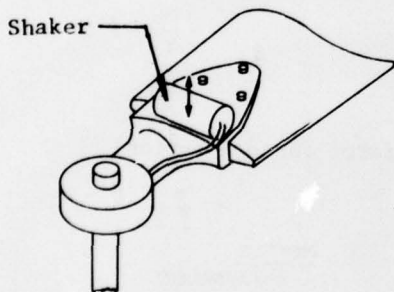

Mode
Beamwise
SHAKER ON BLADE ROOT

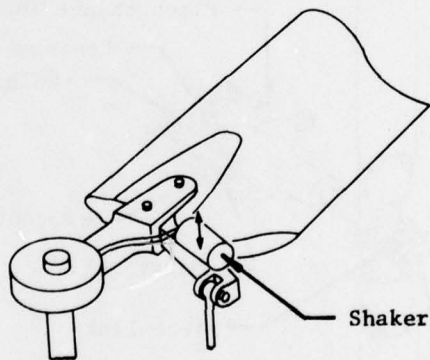

Mode
Beamwise
Torsional
Coupled B/T
SHAKER ON PITCH ARM

Figure 7. Examples of some possible shaker mounting locations

CONTROL SHAKERS

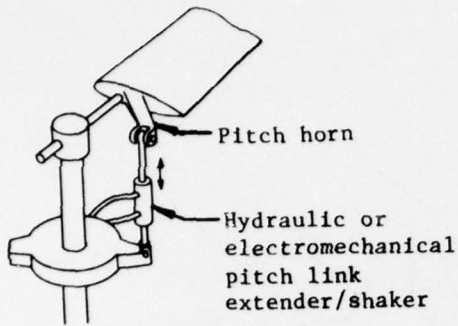

Modes
Beamwise
Torsional
Coupled B/T

SHAKER IN
PITCH LINK
(Rotating System)

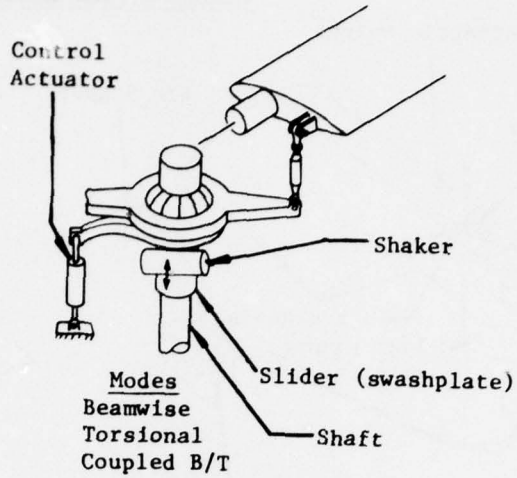

Modes
Beamwise
Torsional
Coupled B/T

SHAKER ON
SWASHPLATE
(Stationary System)

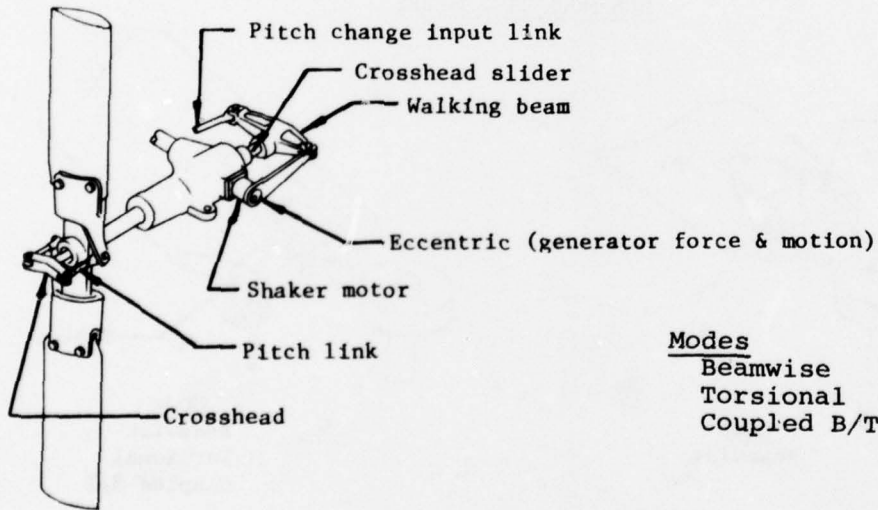

Modes
Beamwise
Torsional
Coupled B/T

TAIL ROTOR SHAKER APPLICATION

Figure 8. Shaker mounting locations

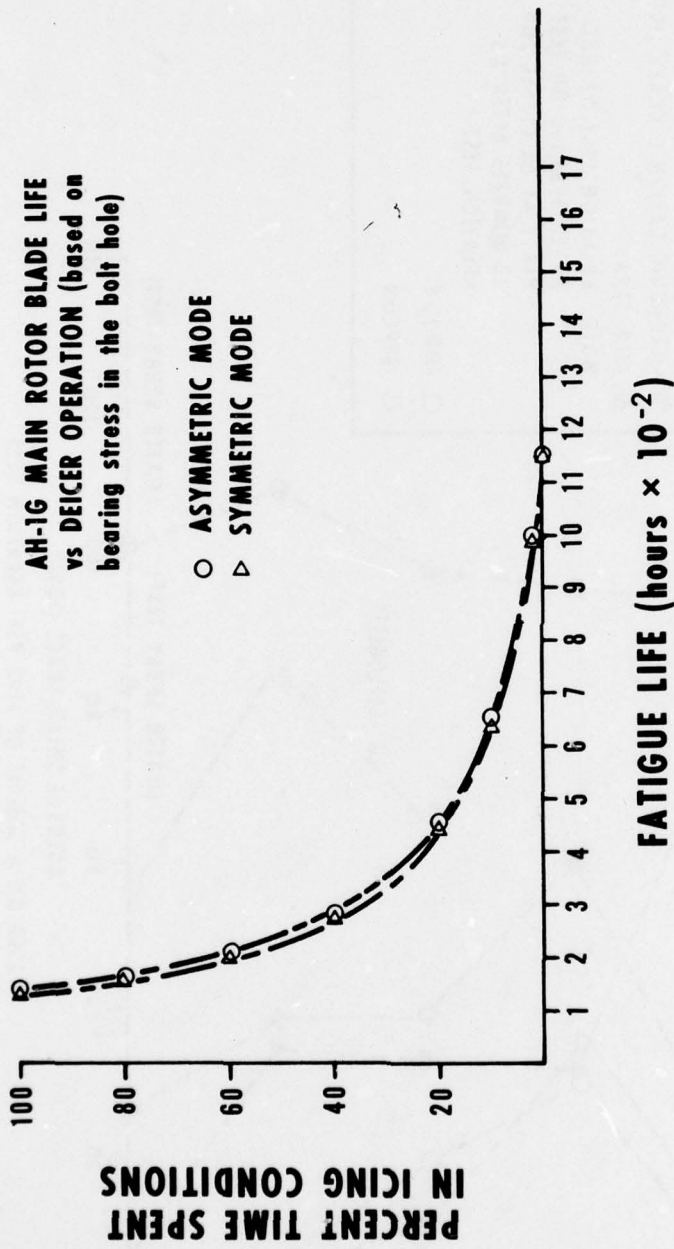
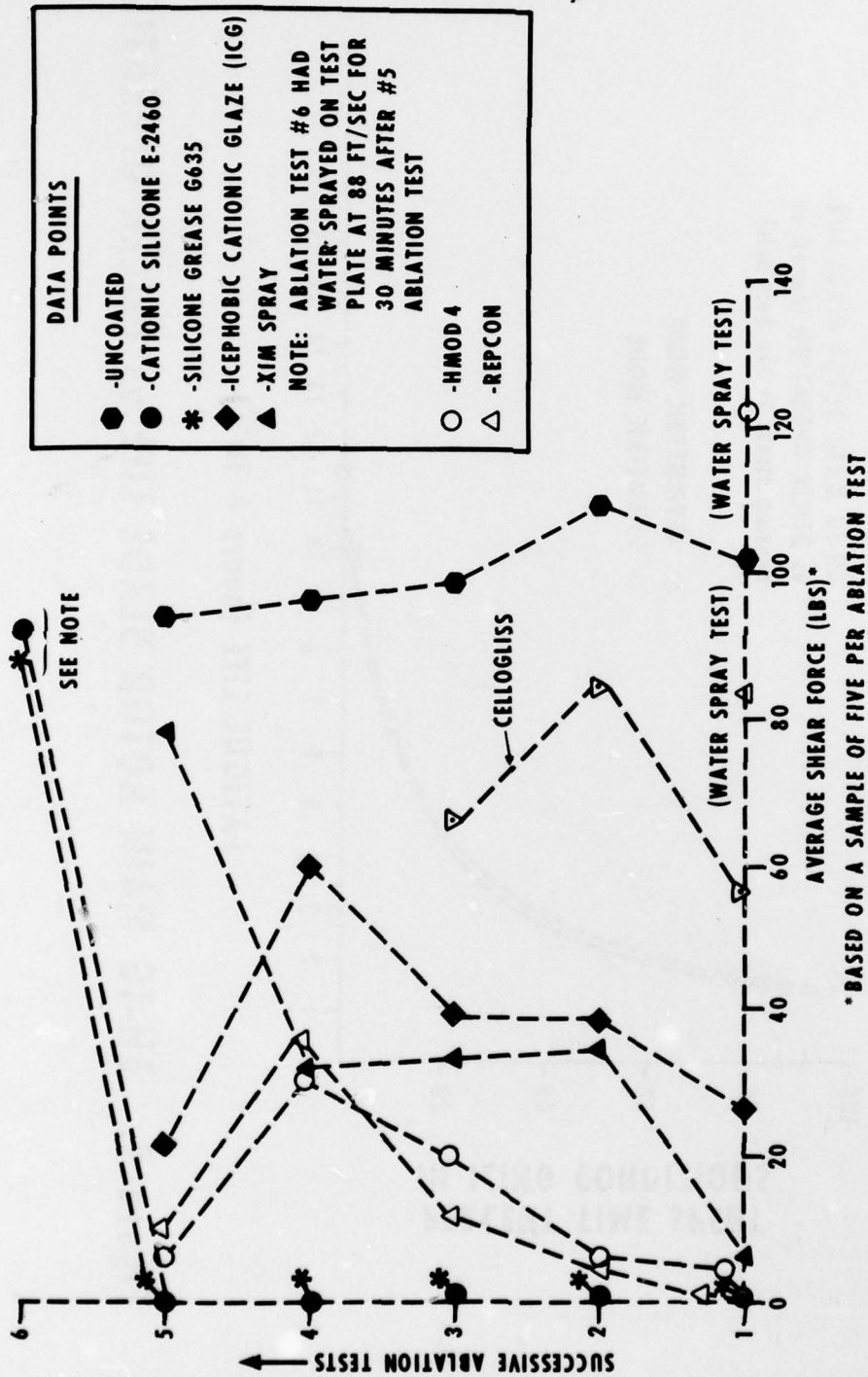

Figure 9. AH-1G MAIN ROTOR BLADE LIFE vs DEICER OPERATION



DATA POINTS

- - UNCOATED
- ◐ - CATIONIC SILICONE E-2460
- * - SILICONE GREASE G635
- ◆ - ICEPHOBIC CATIONIC GLAZE (ICG)
- ▲ - XIM SPRAY
- - HMOD 4
- △ - REPCON

NOTE: ABLATION TEST #6 HAD WATER SPRAYED ON TEST PLATE AT 88 FT/SEC FOR 30 MINUTES AFTER #5 ABLATION TEST

Figure 10

MAIN ROTOR APPLICATION MECHANICAL-PNEUMATIC DEICER

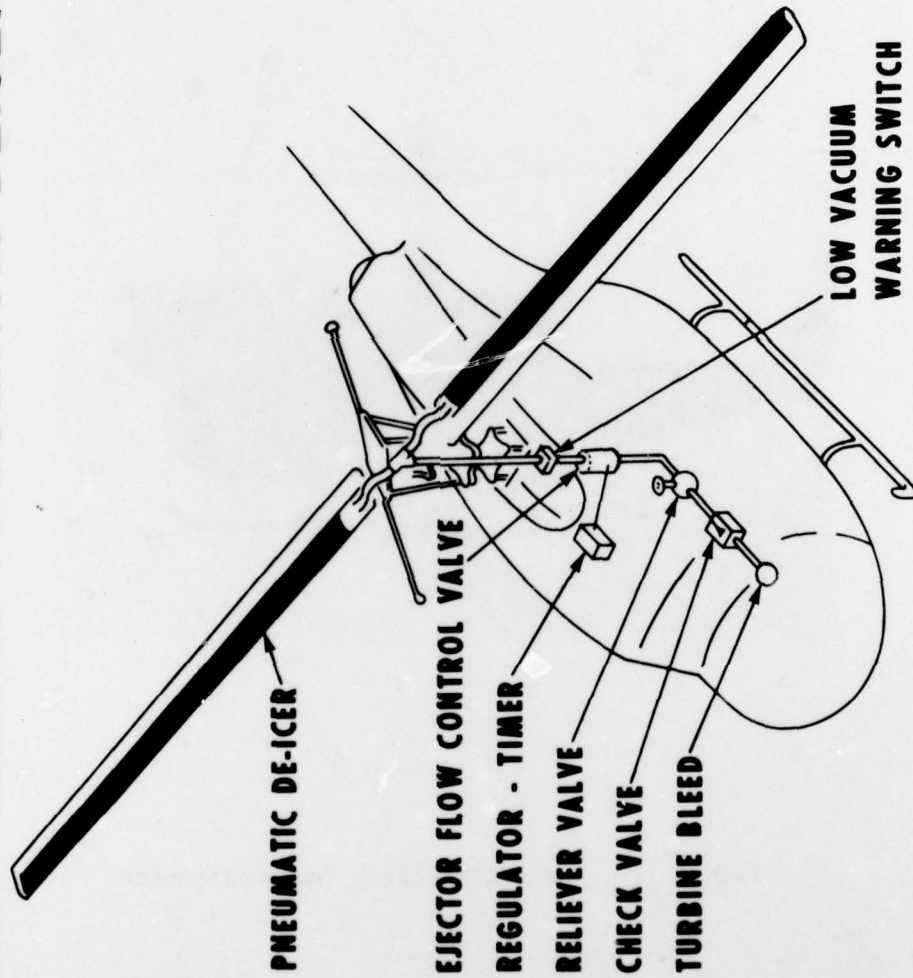

Figure 11.

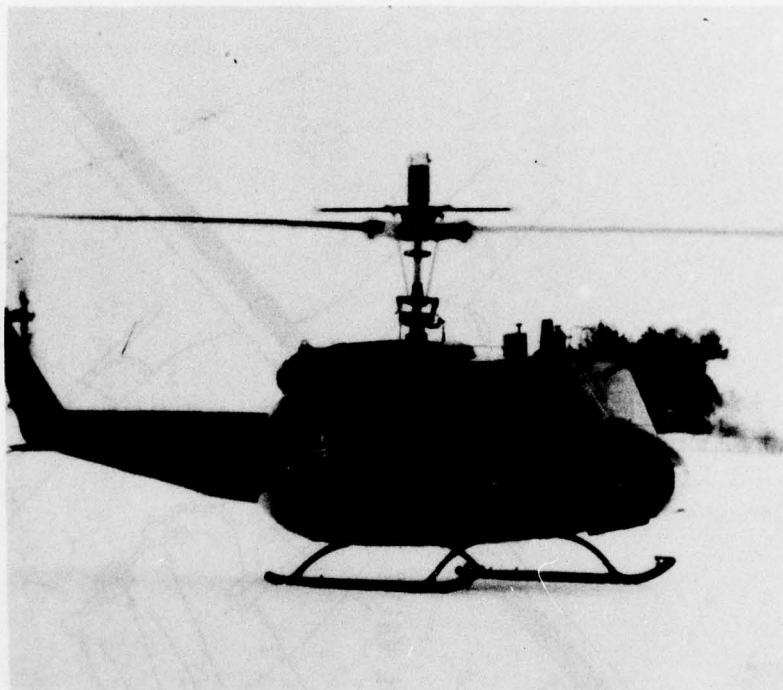

Figure 12. The ATL Research Test Helicopter

BLACKHAWK ICE PROTECTION

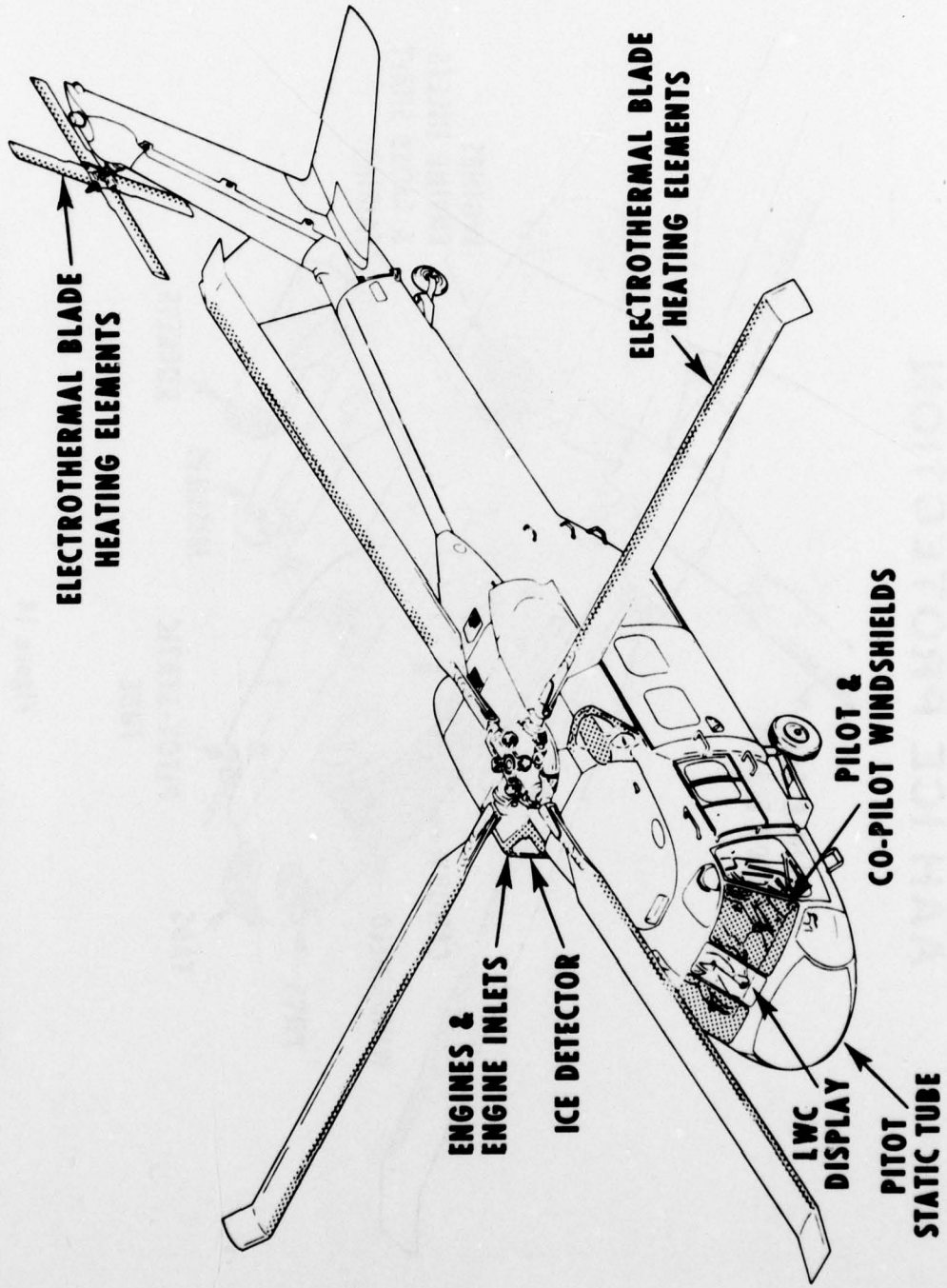

Figure 13

AAH ICE PROTECTION

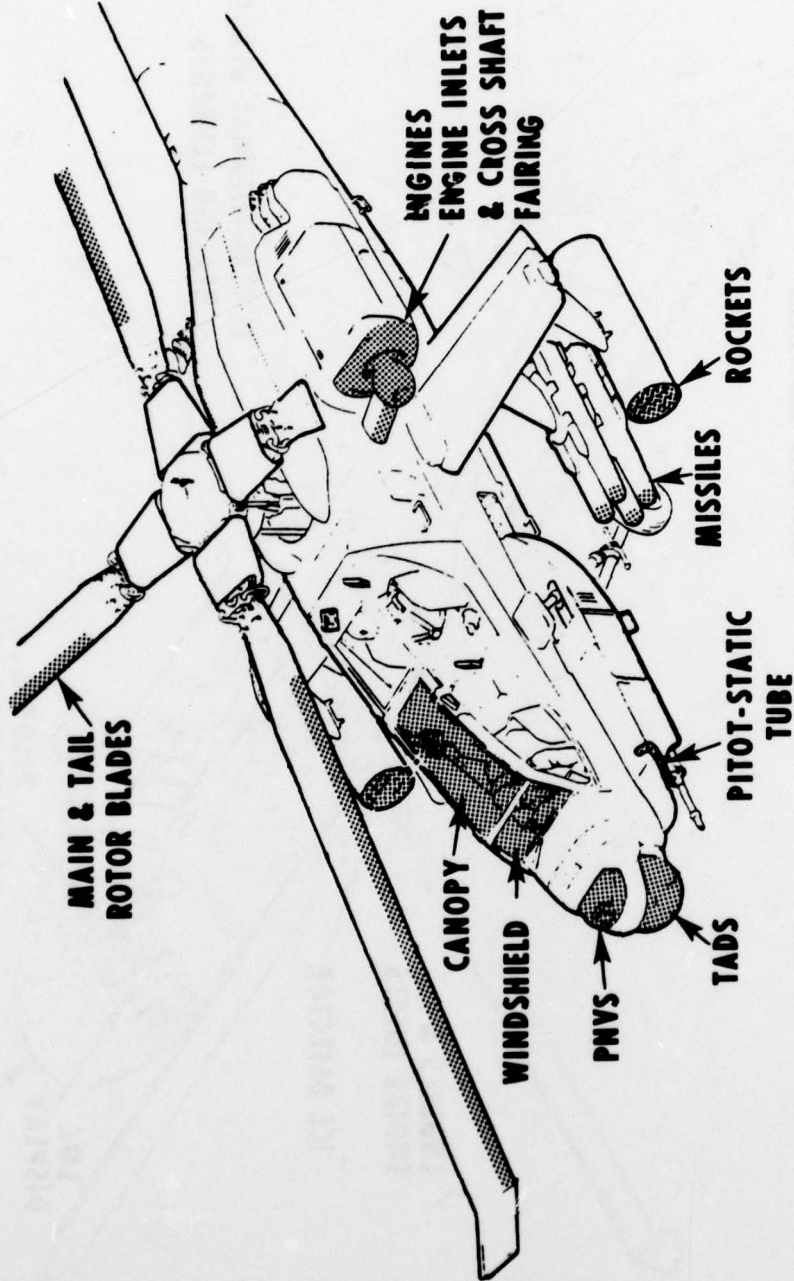

Figure 14

THE DEVELOPMENT OF NEW ICE-SHEDDING SCHEMES

BY

J H SEWELL

Paper for presentation at NATO Panel X Helicopter Icing
Symposium on 6-7 November, 1978

SUMMARY

Wind-tunnel tests and flight trials have demonstrated the ability of RAE-developed pastes to improve ice-shedding from rotor blades. Improvements in paste ice-particle erosion resistance, spray applicability and removal after use are being pursued.

A hybrid heater/paste scheme for deicing rotor blades has shown promise in wind tunnel tests. The narrow-chord electrically heated mat is bonded round the blade leading edge and deicing paste spray-applied to the blade aft of the heater on the upper and lower surfaces. The paste, which sheds accreted and run-back ice, is not nearly as erosion-prone as when applied around the blade leading edge and the heater is much smaller and more simple in operation than an all-heated system. Replacement of paste by a permanent flexible surface is also being investigated in a proposed alternative hybrid rotor blade deicing scheme. Laboratory studies are in progress to determine the most promising flexible coatings for shedding ice under the aerodynamic and centrifugal forces encountered in flight.

In response to a requirement for preventing ice formation on the Lynx ARC 340 homing antenna, an anti-icing paste has been developed which has performed satisfactorily in wind tunnel and icing flight trials. For easy application, it is moulded into blocks which are adhesively bonded directly to the aerial.

1 INTRODUCTION

Heated rotor blades offer a probable long-term technical solution to rotor icing problems but there are associated high cost, power, weight and maintenance penalties and most helicopters in service with UK forces would be exposed to the risk of flying in icing conditions during only a few months every year. The task of retro-fitting existing helicopters with heated blades would be a costly modification and could downgrade the aircraft's performances.

As an alternative to electrothermal de-icing, pastes which either prevent ice formation or improve shedding, even for a short time, have some attractions. The additional costs, power and weight would be low but a smooth coating to minimise performance penalties would be necessary and removal would have to be made relatively simple.

This Paper describes the development of an ice-shedding paste, a hybrid heater/paste and a heater/flexible substrate coating deicing scheme for rotor blades and an anti-icing paste for application to the Lynx ARC 340 homing antenna.

2 DE-ICING PASTES FOR APPLICATION TO ROTOR BLADES

Ideally, an ice-shedding paste must:

- i be easy to apply to a rotor blade leading edge between +20° and -15°C;
- ii be non-corrosive, non-toxic, and not adversely affect the blade materials;
- iii remain on the blade and be effective for at least one flight;
- iv preserve the aerodynamic properties of the blade;
- v lower the freezing point of water sufficiently so that ice is shed continuously and unacceptable torque rises do not occur even in the most severe icing conditions;
- vi be easily removable from a blade surface;
- vii be cheap;
- viii possess an adequate storage life.

As high a proportion of the total volume of a paste as possible should be available for depressing the freezing point of water. The problem in formulating a paste is to retain a freezing-point depressant on a rotor blade in flight and thus the choice of suitable binders to prevent paste flow under shearing forces is an important factor determining the composition of a suitable material.

A search was made to see if any de-icing pastes reported in the literature appeared to be worth investigating. Several compositions were prepared and subjected to a simple screening test in which their ability to release ice was examined. It was decided to evaluate a gelatin-based paste¹ more fully - none of the other formulations appeared to possess the combination of properties required for improving ice-shedding from rotor blades.

Paste 1 was prepared by adding gelatin (11.2g) and gum tragacanth (0.5g) to cold distilled water (19.6g), warming after 5 minutes to 60°C and then slowly adding corrosion-inhibited ethylene glycol (58.7g) and dispersing oil OM-33 (9.0g) with Teepol (1.0g). The paste was re-warmed, brush applied to the leading edge of a Whirlwind helicopter rotor blade section and tested in the icing wind tunnel owned by Lucas Aerospace Ltd at Artington. With a wind speed of 99 m/s at -8°C, liquid water

concentration of 0.65g/m^3 and blade incidence of $+8^\circ$, the paste shed ice continuously for 30 minutes, the thickness of ice on shedding increasing gradually with time. The rectangular tunnel cross-section used in this and all subsequent tests was 500 mm wide and 300 mm high; clear vision panels were fitted to enable observations and photographs to be taken. The original stock of gelation was virtually exhausted, however, and tests with two different commercial gelation samples indicated that the original paste 1 formula would have to be modified as gelling of the paste after application to a surface was too slow. It was therefore decided to examine the effect on paste 1 properties of the type of gelatin, initially using Bloom 50, 100 and 110 gelatins. (Note: the higher the Bloom number, the stiffer is a gel formed with water under identical conditions). In the Artington tunnel, however, all the paste coatings were ripped and torn back from the leading edge of a Whirlwind blade section by the combined effect of the air and hydrostatic pressure within 3 minutes of the start of icing. It was clear that satisfactory pastes of the required toughness and peel strengths could not be obtained using Bloom 50, 100 or 110 gelatins.

Peel strengths on aluminium of pastes having compositions broadly similar to paste 1 but formulated with Bloom 150, 200 and 250 gelatins (both limed and acid-extraction process types) were determined; Bloom 250 gelatin is the highest Bloom number normally manufactured and would be expected to produce the stiffest and toughest paste for a given composition. The peel adhesive strengths of the pastes on flat aluminium panels were very low compared with that of paste 1 which incorporated the original gelatin. Peel strengths on 0.5 mm thick rain erosion-resistant polyurethane sheet to specification WGPS 240 were also very low. It was therefore clear that further investigation of the paste formulation would have to be made in order to obtain satisfactory adhesion.

Measurements of peel adhesion of pastes containing Bloom 150, 200 or 250 gelatins were made on aluminium and on polyurethane surfaces using glycerol instead of ethylene glycol as a freezing-point depressant since the use of the former had been suggested in the original patent; gum tragacanth was omitted from the formulae as it had not appeared to make a useful contribution to paste properties in previous compositions. The substitution of glycerol for glycol in these pastes resulted in significant increases in peel adhesion and three pastes, based on gelled glycerol using Bloom 200 limed gelatin, were evaluated more fully with the aim of selecting one for flight trials on rotor blades. All three pastes shed ice for about 1 hour in the Artington wind tunnel at 99 m/s, -8°C and 0.65g/m^3 liquid water concentration.

Paste 2 was applied to the outer 50% of the leading edges of all four blades of a Puma helicopter specially instrumented for measuring rotor blade performance. Deterioration of the blade aerodynamics could be detected by an increase in the load on the pitch-control link, while changes in the rotor torque could be deduced from changes in the root lag-angle. Paste 2, the most promising found during the Artington tests comprised glycerol (29 parts by weight), gelatin (6), water (10), oil OM-33 (5) and propan-2-ol solvent (11). It was applied by chordwise brushing for the first flight and by spanwise brushing for the second to a thickness of about 0.5 mm and flown the day after application. (Note: the paste can be applied by spraying a warm solution using an electrically-heated spray cup). The first flight took place in light rain for 1 hour; examination of the rotor blades immediately after landing showed that the paste had been eroded from the stagnation region. During the second flight, there was no rain and flights at 10,000 ft, 5,000 ft and 2,000 ft were made. At high thrust coefficients, there was an increase in vibration levels and pitch-link loads began to exceed infinite fatigue life limits above 120 kn IAS. However, below this air speed and at the medium and low thrust coefficients up to 150 kn no significant effects were noticed. Thus application of the paste to the Puma was considered to be satisfactory from the aerodynamic aspect and examination showed that the paste was in good condition and still active after the flight.

The effect of ice-particle impact was assessed in the Artington tunnel. Various pastes were brushed 0.5 mm thick on to the leading edges of a Whirlwind helicopter rotor blade section, hardened for 20 hours at 20°C and placed in the wind tunnel at 8° incidence. Granular ice particles of concentration 0.65 g/m³, having maximum dimensions of 1 mm in any direction, were introduced into the 99 m/s airstream at -10°C; after about 6 minutes, each paste was completely eroded from the stagnation region of the blade and it was clear that greater resistance to ice-particle impact was required of pastes used for rotor blade application. It is of interest that flight tests of Paste 2 on a Sea King helicopter in Canada early in 1977 showed that, although the aircraft was not instrumented to determine relative ice-shedding characteristics, blades to which paste was applied appeared to have improved shedding properties. However, a flight in falling snow caused erosion of the paste in the blade stagnation region, confirming the need for improving the paste resistance to ice-particle impact.

3 HYBRID ROTOR BLADE ICING PROTECTION SCHEMES

Composite flexible coatings represent another possible blade protection system. These comprise an outer surface bonded to a flexible sponge rubber substrate which is in turn bonded to the blade. Laboratory tests have shown that ice has very low adhesion to such a system but subsequent flight trials showed that accreted ice could remain in the stagnation region of the blade to the detriment of the aerodynamic properties.

Hybrid systems are being investigated in which a narrow chord heater mat is used for anti-or de-icing the stagnation region and aft of this, on both the upper and lower surfaces of the blade, either a paste or a flexible substrate coating is applied. The aim is for the heater to prevent unacceptable ice accretions in the stagnation region, where the paste is prone to erosion and the flexible substrate coating is inefficient, whilst the paste or flexible coating would shed run-back and accreted ice aft of the heater mat. Either hybrid combination would be lighter, less costly to operate and install, use considerably less power and be less complex than an all-heated blade protection scheme.

3.1 Hybrid Heater/Paste System

Metal foil element electrical heater mats were prepared and bonded by Dunlop Ltd, Aviation Division, Coventry, to the leading edges of two 750 mm long Wessex helicopter main rotor blade sections. The mats were of a complex sandwich construction employing polyurethane rubber as the exposed surface material, one mat being 40 mm wide and the other 50 mm wide; each was 480 mm long and when in their bonded positions extended chordwise further on the blade underside than on the upper side to allow for an angle of incidence on the blade when testing. Thermocouples were positioned in each mat so that the element temperature could be monitored continuously.

Pastes similar in composition to paste 2 were spray-applied to the upper and lower surfaces of the blade aft of the heater and extended rearwards to about 30% of chord. A spray gun fitted with an electrically-heated spray cup for melting the paste was used to provide a smooth paste surface on the blade; the original pastes were designed for brush application, but modifications were made in the formulations to enable them to be sprayed and tests made in an "arctic chamber" to check the sprayability down to -15°C.

The blade sections were installed at +8° incidence in the working section of the Artington wind tunnel. During the icing tests, the air speed was maintained at 100 m/s, the static temperature was varied between 0° and -20°C and water droplets were between 20 and 40 µm in diameter; the liquid water concentration in the airstream was adjusted so that "continuous maximum" icing conditions were achieved.

Heater mat performance was assessed with regard to the continuous power required and the associated element temperature to just prevent ice forming at a given tunnel temperature. Under de-icing conditions, the power input and tunnel temperature were noted when accreted ice on the blade stagnation zone shed when 3-4 mm thick. The 50 mm wide mat was more efficient than the 40 mm mat in terms of power required for a given performance, being capable of anti-icing down to -19°C ; at -20°C there was slight ice accretion but shedding always occurred before the ice reached 7 mm thick. Centrifugal forces present in flight conditions would greatly assist the shedding. The de-icing and anti-icing thresholds shown in Figure 1 represent continuous power application to the whole of the heater element and no attempt was made to cycle the power supply. When the mats were operated in icing conditions without paste on the blades, there was build-up of run-back ice behind the heater mat and this ice did not shed. With pastes present, both accreted and run-back ice shed continuously for the duration of the test (1 hour), the thickness of accretion on the paste not exceeding 4 mm before shedding. One paste in particular showed good resistance to erosion when exposed to 0.65 g/m^3 ice-particle concentration at 100 m/s, confirming that if the paste can be kept away from the blade stagnation region, the erosion problem is greatly reduced.

A step present aft of the heater mat appeared to afford some degree of protection to the pastes, but when the latter were applied in thicknesses greater than the step height they tended to lift and tear in the airflow. A step will be incorporated in future designs as it is believed that aerodynamic penalties will be minimal provided that the discontinuity occurs more than 5% of chord behind the leading edge of the blade.

The logistic disadvantages of a spray system requiring both compressed air and electrical supplies in remote airfield hangars or on board ship may be outweighed considering the additional time penalty and relatively rough coating attendant with brush application. It is estimated that one hot spray cup containing 1 litre of paste would be sufficient for coating each Sea King helicopter main rotor blade.

3.2 Hybrid Heater/Flexible Substrate Scheme

Work on this hybrid scheme has so far been concentrated on development of the flexible coating component of the proposed system. A coating consisting of 0.64 mm thick polyurethane rain erosion resistant sheet on 1.6 mm thick closed-cell natural rubber sponge was originally proposed for flight trials. However, tests revealed that the soft substrate would be destroyed by droplet impact through rain, so the sponge rubber around the blade leading edge in the stagnation area was replaced by a hard solid rubber strip. This modified coating was applied to two opposite rotor blades of a Wessex 5 helicopter, the other two blades being uncoated so that ice-shedding comparisons could be made. Flight trials were made at Tirstrup, Denmark, but in the climatic conditions encountered (the air temperature did not fall below -5°C), ice formed only on the stagnation region of the blades and not on the parts of the coating where the flexible sponge rubber substrate was present. Thus as ice formed on hard, inflexible surfaces on both modified and unmodified blades, no difference in shedding characteristics would have been expected, or was, in fact, observed. It was considered impracticable to develop a flexible erosion-resistant leading edge coating since distortions would inevitably occur in this aerodynamically sensitive region which could seriously degrade the performance of the blade. A hybrid de-icing system comprising a flexible substrate composite coating on both upper and lower blade surfaces aft of an electrically heated leading edge was therefore proposed. The aim was to shed or to prevent ice forming on the heated zone and to allow run-back and accreted ice to be shed under centrifugal and aerodynamic forces from the flexible coating.

An investigation was made to find the best materials for the composite flexible substrate coatings. It was decided to retain the 1.6 mm thick closed-cell natural

rubber sponge as the substrate and to concentrate on the properties of the outer surface. Surface materials chosen for initial evaluation were shim steel, copper, copper-beryllium, phosphor bronze, low density polyethylene and nylon 6. Films of these materials, measuring about 80 x 100 mm, were bonded to the sponge rubber substrate of the same dimensions which was in turn stuck down to a rigid metal backing plate, a flexible adhesive being used throughout.

The shear adhesion of ice to the various composite test surfaces was measured as this form of loading most closely resembled the forces on ice accreted on rotating blades. Inside a freezer cabinet, a circular wooden block 5 mm thick with a strip of woven cotton bonded to the upper face was placed on the experimental surface and the gap between the lower face of the block and the surface completely filled with distilled water, excess water being removed. This was allowed to freeze at -16°C for 20 mins with a load of 100 g on top of the block; the frozen area was 5 cm^2 . Ice adhesion was determined by attaching a scale pan to the end of the cotton strip, securing the base of the experimental surface on a horizontal platform in the freezer cabinet, passing the cotton strip over a pulley so that the pan hung vertically and loading the latter with 250 g weights every 15 secs until failure occurred. At least 10 measurements were made on different parts of each surface and a statistical analysis of variance was used to see whether the ice adhesion values for the various surfaces were significantly different. In order to investigate the relationship between ice adhesion and surface flexibility under load, the 5 mm diameter flat base of a dial gauge was positioned vertically touching the experimental surface. Loads were applied to a pan on top of the dial gauge rod and the indentation against load recorded. The relative water wettabilities of the metal samples were compared with the ice adhesion results to see whether any correlation existed. Distilled water (0.5 cm^3) was deposited on to the vapour degreased metal surface bonded directly to a rigid substrate and the area covered by the water was measured - the larger the area the more wettable the surface.

The shear adhesion of ice to the composite coatings is given in Table 1. Tests using square wooden blocks instead of circular ones of the same area showed no significant difference in ice adhesion. Increase in surface flexibility resulted in lower ice adhesion values for the polyethylene samples tested but no correlation was found between flexibility, water wettability and ice adhesion for the metals although the adhesion of ice to these samples was considerably lower than would be expected if the sample surfaces were rigid. Despite the standard deviation from the mean being large in several cases, the analysis of variance showed that the ice adhesion to the various surfaces was significant to greater than 0.1%; this indicated that it was possible to place the different test samples in order of relative ice-shedding effectiveness.

A relationship between the ice-shedding behaviour of a coating in the laboratory and on a rotating helicopter blade in flight is difficult to predict because in the latter case a much larger area of ice is usually shed at any one instance than the 5 cm^2 area that was removed in the laboratory tests. Ice adhesion per unit area tends to decrease with increase in area of adhesion and also aerodynamic forces which assist ice release are difficult to simulate in laboratory tests. However, a load parallel to the test surface which was applied to the cotton strip attached to the wood block during the laboratory tests approximates to a centrifugal force acting through the centre of gravity of an ice block of double the wood block thickness. Calculations show that ice should shed from sample 9, Table 1, from outboard of 60% of span on a 8.2 m long blade rotating with a tip speed of 207 m/s. However, a rotating rig test would be necessary to verify this. The metal foils which are thin enough to shed ice from rotor blades are probably not strong enough or sufficiently impact-resistant to merit further consideration; a wider selection of materials, particularly polymers, for both surfaces and substrates will be examined in the future.

An anti-icing paste was specially developed for application to the Lynx ARC 340 aerial. Tests showed that when the helicopter was hovering in ground effect, lumps of ice shed from the aerial could be ingested by the engines and might damage the compressor blades. There was thus a requirement for preventing ice forming on the upper arm of the aerial and, amongst other possibilities, use of an anti-icing paste, ie a surface on which water would not freeze down to -26°C , was proposed.

Early experiments both in static conditions and in a small icing wind tunnel in EP Department, RAE, confirmed that the gelatin-based pastes already under development for use on rotor blades were unsuitable for application to the antenna. These pastes present surfaces which have very low adhesion to ice but do not prevent its formation initially and accretions could in certain circumstances be of such a mass as to cause damage to engines if ingested.

It was therefore decided to concentrate work on developing a new anti-icing paste. Liquid freezing-point depressants did not display anti-icing properties in the rotor-blade de-icing pastes, although they were present in relatively high proportions. The possibility of using water-soluble freezing-point depressant solids in anti-icing paste compositions was examined. Choice of solid for this purpose depends on several factors, particularly cost, eutectic temperature (ie, the lowest temperature at which the depressant will melt ice), concentration of solid at the eutectic, and toxic and corrosive properties. Calcium chloride was chosen for evaluation as it has a low eutectic temperature of -55°C (sodium chloride has a eutectic of only -21°C), is readily soluble in cold water and is cheap. A material was required to bind the calcium chloride powder together and to hold it in place on the aerial and various types and properties of calcium chloride mixed with different binding media were prepared and tested. Experimental pastes were applied to flat metal plates and exposed to a water spray in an "arctic chamber" between -10 and -20°C . An effective paste was totally dissolved by the water before ice build-up commenced. The more promising pastes were applied to 19 mm outside diameter tubes and tested in the Artington wind tunnel at up to 100 m/s wind speed and 0.65 g/m^3 liquid water content at -8°C . It was found that only a mixture of anhydrous calcium chloride in alcohol-soluble nylon was fully effective in the tests. Also the size of the calcium chloride granules was very important in determining the anti-icing life of the paste; the best performance was obtained with material having a 12 to 24 mesh size.

The chosen paste needed to be warmed to facilitate application and it was a laborious task to spread it on to the circular section of the aerial. Therefore, the paste was moulded in a press to the required shape; a rigid block was formed which could be bonded to the aerial using a pressure-sensitive adhesive. Icing tests on a Lynx fuselage in Cell 3 West at NGTE, Pyestock, confirmed the promise of this approach and subsequent flight-clearance trials in the blower tunnel at A & AEE, Boscombe Down, showed that 13 mm thick paste blocks moulded with a pressure of $40,000\text{ kN/m}^2$ had anti-icing lives of about 45 min in a 70 kn airstream with 1g/m^3 liquid water content at -7°C . Flight trials on a Lynx helicopter in Canada early in 1978 demonstrated that the paste blocks provided a feasible solution to the antenna icing problem.

Materials Department
RAE
Farnborough

8 September 1978

125

REFERENCES

| <u>No</u> | <u>Author</u> | <u>Title, etc</u> |
|-----------|------------------------|--|
| 1 | H L West A R Ogston | Compositions for the prevention of the formation or accretion of ice on exposed surfaces. United States Patent Specification 2373727 (1945). |

Table 1

Shear adhesion of ice to metal and polymer films having 1.6 mm thick flexible
sponge rubber substrates

| Sample No | Film or foil | | Shear adhesion of ice (kN/m ²) | |
|-----------|---|----------------|--|--------------------|
| | Type | Thickness (mm) | Mean | Standard deviation |
| 1 | Shim steel | 0.076 | 43.9 | 25.1 |
| 2 | Shim steel | 0.127 | 58.0 | 21.7 |
| 3 | Commercial copper | 0.076 | 39.3 | 11.4 |
| 4 | Hard copper | 0.102 | 52.6 | 22.3 |
| 5 | Copper beryllium, half hard | 0.076 | 53.7 | 19.8 |
| 6 | Copper beryllium, half hard | 0.102 | 60.4 | 27.9 |
| 7 | Phospher bronze | 0.152 | 68.0 | 37.1 |
| 8 | Polyethylene, low density | 0.127 | 36.4 | 12.0 |
| 9 | Polyethylene, low density | 0.254 | 25.8 | 6.7 |
| 10 | Polyethylene, low density | 0.508 | 46.4 | 24.0 |
| 11 | Nylon 6 | 0.254 | 62.2 | 28.6 |
| 12 | Shim steel, 50 mm wide strip | 0.076 | 44.1 | 17.0 |
| 13 | Copper beryllium | 0.076 | 48.0 | 14.9 |
| 14 | Commercial copper on 3.2 mm thick sponge rubber substrate | 0.076 | 42.9 | 6.6 |

FIG.1
Anti-icing and de-icing
threshold, 50mm mat

