

AD-A068 012

TACTICAL AIR COMMAND LANGLEY AFB VA CONCEPTS DIV
A USER'S GUIDE FOR TAC PERT.(U)
APR 79 H J TALLEY
TAC/XPB-TN-79-5

F/6 9/2

UNCLASSIFIED

NL

| OF |
AD
A068012



END
DATE
FILMED
6-79
DDC

XPB TN 79-5

LEVEL

②
B.S.



OPERATIONS ANALYSIS DIVISION
DIRECTORATE OF MISSION AREA PLANNING
DCS PLANS

12 April 1979

AD A068012

A USER'S GUIDE
FOR
TAC PERT

DDC
RECEIVED
MAY 2 1979
DDC

DDC FILE COPY

Approved for Public Release
Distribution Unlimited

This document has been approved
for public release and sale; its
distribution is unlimited.

79 04 30

OPERATIONS ANALYSIS DIVISION

DCS/PLANS

2

11 22 Apr 77

12 54p

9 TECHNICAL NOTE 79-5 ✓

6 A USER'S GUIDE
FOR
TAC PERT

DDC
RECEIVED
MAY 2 1979
ALBANY
C

Prepared By:
EDWARD H. MERRY
Operations Analyst

14 TAC/XPB-TN-79-5

10 APPROVED BY:
HOWARD J. TALLEY, JR
Chief, Operations Analysis Division

United States Air Force
HEADQUARTERS TACTICAL AIR COMMAND
Langley Air Force Base, VA 23665

410 811 gm

This document has been approved
for public release and sale; its
distribution is unlimited.

ABSTRACT

This technical note documents the use of the Program Evaluation and Review Technique (PERT) to assist in the close management of large programs. This note includes a general description of PERT methodology, specific conventions used in adopting this methodology to TAC's hardware and software, a description of the output products available and a discussion of utility and requirements of this tool in program management. The results are referred to as TAC PERT.

TABLE OF CONTENTS

	<u>PAGE</u>
Title Page	i
Abstract.	ii
Table of Contents	iii
List of Figures and Tables.	iv
 SECTION	
I. INTRODUCTION.	1
A. Management Need	1
B. Detailed Planning and Control	1
C. Purpose	1
II. PERT DESCRIPTION.	1
A. Network Analysis Techniques	1
B. Work Breakdown Structure.	2
C. Logic Determination	4
D. Time Estimates.	7
E. PERT Computation.	8
III. PRODUCT DESCRIPTION	14
A. Types of Output Products.	14
B. TAC PERT Output Products.	14
IV. TAC PERT STANDARDIZATIONS	26
A. Overview.	26
B. Standardized Coding	26
C. Slack Analysis.	35
D. Program Update.	38
Bibliography.	41
Glossary.	42
Distribution.	46

ACCESSION for	
NTIS	Write Section <input checked="" type="checkbox"/>
DOC	B-ft Section <input type="checkbox"/>
UNANNOUNCED	<input type="checkbox"/>
JUSTIFICATION	
BY	
DISTRIBUTION/AVAILABILITY CODES	
Dist	SPECIAL
A	

LIST OF FIGURES AND TABLES

FIGURES

<u>NO.</u>	<u>TITLE</u>	<u>PAGE</u>
1	Level 1 Work Breakdown	1
2	Level 2 Work Breakdown	1
3	Level 3 Work Breakdown	4
4	Renovate A Training Facility	5
5	Duplicate Entry Error Statement	6
6	Work Center Subnetwork	6
7	Mobility Exercise	7
8	Example Forward Pass Computation	10
9	Example Backward Pass Computation	11
10	Stock Example	13
11	Example TAC PERT Listing	16
12	TAC PERT Bar Chart	18
13	Example Activity Block	19
14	Network Legend	22
15	Example Network	23
16	Example X-Y Plot	25
17	Base Detail Implementation	28
18	Work Center Detail	29
19	EX PERT Plotter Commands	30
20	PERT Input Format	34
21	TAC PERT Slack Listing	37
22	PERT Update and Execution	40

TABLES

<u>NO.</u>	<u>TITLE</u>	<u>PAGE</u>
1	PERT Editorial Rules	8
2	List of Abbreviations	15
3	Standard Numbering for Key Events	27
4	Example Data Source Code	29

A USER'S GUIDE FOR TAC PERT

I. INTRODUCTION.

A. Management Need. During the next several years, many TAC units will be converting to newer systems. There will also be repositioning of units and modernization of unit equipment through major modifications. These conversions, repositionings, and modernization actions, along with the impacts of foreign military sales, have the potential for creating much turbulence in the Tactical Air Forces (TAF). Very careful and close management is often required to assure that the right equipment and properly trained people are at the right places at the right times to maintain TAF readiness at the highest possible level.

B. Detailed Planning and Control. As an aid to managers in accomplishing the detailed planning and in maintaining the close control required to keep complex programs on schedule, we have made available an automated management tool called PERT (Program Evaluation and Review Technique) at Headquarters Tactical Air Command. Simply described, PERT consists of selecting a goal, listing the tasks required to arrive at this goal, together with the time required to do each task, and linking them in logical order. From this, the overall time to reach the goal and the date when each task can be, or must be, started can be computed. Most importantly, those tasks which directly control the overall completion date can be identified and carefully monitored during execution.

C. Purpose. The purpose of this paper is to explain PERT and its products, our development of this management tool on TAC computers, and the values and requirements of this technique in effective program control. This management tool is referred to as TAC PERT.

II. PERT DESCRIPTION.

This section provides a general explanation of network analysis techniques of which PERT is one, as a means of planning and controlling numerous complex activities to reach a predetermined goal. Illustrations of logic development, computations, and output products use a TAC unit aircraft conversion program as examples. PERT is applicable to any large complex program but our impetus and most of our experience is unit conversions to new weapons systems.

A. Network Analysis Techniques.

1. Program Characteristics. Numerous planning techniques are available to program managers. However, there are three characteristics of a program which indicate that the manager should consider using network analysis techniques and PERT in particular.

a. The program is essentially a one-time effort and the managers involved have limited experience directly applicable to managing new programs.

b. The program effort is both monumental and complex involving numerous activities.

c. Time phased bar charts do not adequately display the interrelationships and dependencies of the program activities.

2. PERT-vs-CPM. In response to a need for management tools for controlling programs with these characteristics, two distinct but very similar network techniques were developed in the late 1950s. These techniques are labelled PERT, for Program Evaluation and Review Techniques, and CPM for Critical Path Method. Over the years the similarities of these two techniques have overshadowed the distinctions. The essential difference is that CPM uses a single time estimate of each activity duration whereas PERT uses three time estimates (optimistic, pessimistic, and most likely) of activity duration and combines these times statistically. Within this paper the term "PERT" is used but a single time estimate is employed for each activity.

3. Essential features of PERT. Common to both CPM and PERT is a methodology characterized by:

a. A goal-oriented work breakdown structure beginning with an overall program objective subdivided into successively smaller sub-tasks.

b. A flow plan, called a network, consisting of all activities that must be accomplished to reach the program objectives, and showing their planned sequence of accomplishment, interdependencies, and precedence relationships.

c. Estimates of time required to accomplish each activity.

d. Single agency responsible for each activity.

e. Analysis of the interrelated networks, schedules, and time estimates as a basis for continuous evaluation of program status, forecast of overruns, and the identification of problem areas in sufficient time for management to take corrective action.

B. Work Breakdown Structure. The first step in a PERT development is a systematic identification of all the activities needed to achieve the overall program objective. This is usually called a "work breakdown" structure. This is illustrated using an example from a program to convert a tactical fighter unit from one aircraft type to another.

1. Level 1 Detail. The overall program objective (Level 1) is defined in Figure 1. This objective comes from the USAF Programming Document (PD) which is the plan for force beddown by quarter for the next five years. The plan defines the numbers of each type aircraft authorized to each squadron and the date that an operational capability in the new aircraft must be achieved. An "X" denotes operational capability in the weapon system. The "F" denotes the quarter in which the new aircraft arrives.

Figure 1
Level 1 Work Breakdown
Fiscal Quarters

XYZ TFW		1	2	3	4	1	2	3
A TFS	24 X F-4E	X	X					
	24 X F-15			F	X	X	X	X
B TFS	24 X F-4E	X	X	X				
	24 X F-15				F	X	X	X

2. Level 2 Detail. The program objective is subdivided into major milestones that are of interest to program managers. In our example, Level 2 usually corresponds to the milestones found in the concept portion of a programming plan. Also this level (Figure 2) shows the major resources needed to provide operational capability. (Aircraft, aircrews, support equipment, spares, trained maintenance personnel, facilities, etc.)

Figure 2
Level 2 Work Breakdown
Major Program Milestones

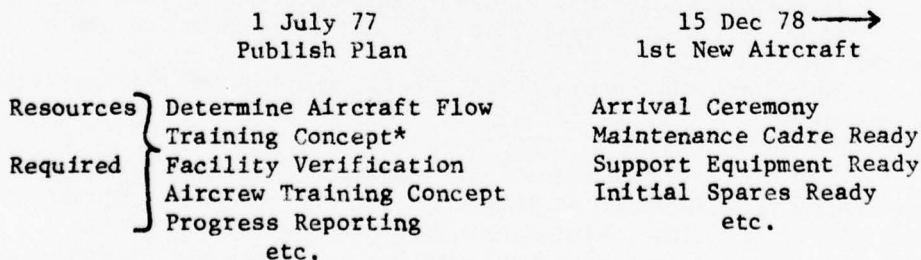

*Example to be expanded in Level 3.

3. Level 3 Detail. These major system components are systematically broken down into activities that must be accomplished. Frequently the activities are sorted by OPR at this time. As shown in Figure 3, the ability to portray the entire program at this level is difficult because of the number of activities involved. The overriding motive is to systematically determine at each level what is needed to accomplish each goal and subgoal.

Figure 3
Level 3 Work Breakdown

A training concept requires:

1. Field Training Detachment (FTD) Classrooms
 2. FTD Instructors
 3. Technical Data (Technical Orders, Checklists)
 4. Training Aids
 5. Course Syllabus
 6. Spare Parts to Support Training Aids
 7. A source of on-the-job (OJT) experience
 8. Hands-on training aircraft.
- etc.

4. Moderating Guideline. Obviously, this method can be carried to extremes in detail. Some moderating guideline is needed. The level of detail should be tailored to the program managers needs. Unit conversion activities should be subdivided until they are, at most, 4-8 weeks in duration. Such activities are of manageable size, are perceived as the "near future", but are not subject to uncontrolled turbulence (illness, holidays, minor weather impacts, etc.) in day-by-day execution.

C. Logic Determination. Once an activity list is prepared, some method of tying these activities together into a logical network is needed. The network should be constructed from logical and technical dependencies. For each activity the operative questions should be:

Which activities may be done concurrently with this one,
Which activities must be completed before this one can be started, and
Which activities cannot be started until after this activity is completed.

1. Activity Relationships. Figure 4 illustrates each of these three relationships as they affect event number 8. Termination of old training (maintenance shop) is independent of the invitation for bid (a procurement action) and hence may be done concurrently.

Figure 4
Renovate A Training Facility

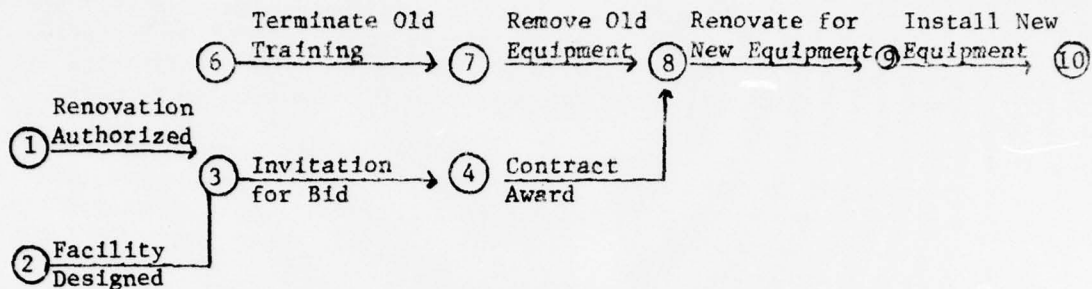

In the second case, the construction must be authorized and a facility designed before a bid may be solicited and a contract awarded. Similarly in the third case we must terminate existing training before removing training aids, test stations, and classroom equipment.

2. Event Number Assignment. The logic sketched in Figure 4 is defined and conveyed to the computer through the assignment of predecessor and successor event numbers. Each activity has two events (start of the activity and completion of the activity) which are displayed as circles, hexagons, or rectangles with numbers printed inside.

a. Concurrent activities have different predecessor and/or successor event numbers (e.g., 6 and 7 for Terminate Old Training; 3 and 4 for Invitation For Bid).

b. Concurrent activities both of which must be completed before starting the next activity have the same successor event numbers, but different predecessor numbers. Activities 1-3 and 2-3 or 7-8 and 4-8 in Figure 4 are examples of this.

c. Similarly in series activities, the successor event number of each activity is the same as the predecessor event number of the following activity. For example, Invitation for Bid successor event number (4) is the predecessor event number of Contract Award. (4,8).

d. The WWMCCS PERT software does not require that event numbers occur in ascending numeric order. This freedom in assigning event numbers (up to 8 digits long) allows the user to:

(1) Assign a block of numbers to a given work center or functional area. (e.g., 33 MAW - 660000 to 670000), and

79 04 30 000

(2) Provide for activity growth within work centers or functional areas while preserving the above number blocks.

3. Construction Dummies. An inspection of a PERT network will reveal a number of activities labelled "CD" or "Construction Dummy". These activities are indeed artificial activities or dummies. There are three frequent uses of construction dummies;

a. A dummy is useful to satisfy the unique predecessor/successor number requirement when two independent activities have the same start and finish points (Figure 5). Since many activities are independent of all others, this use of construction dummies occurs frequently.

Figure 5
Duplicate Entry Error Statement

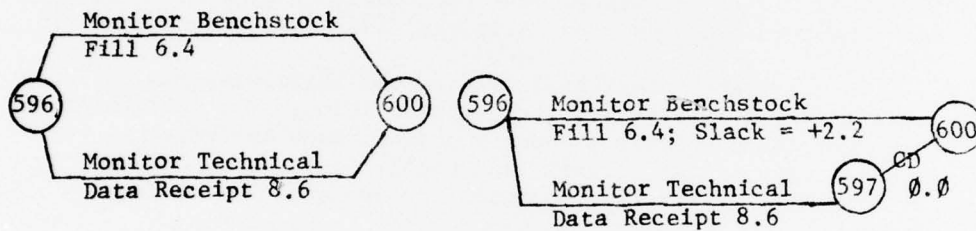

RESULT:

- A. Duplicate entry error
- B. Shorter activity ignored

RESULT

- A. No error messages
- B. 2.2 weeks slack computed (8.6-6.4)

b. Second, a construction dummy may be used to start or collect parallel activities at a single point when making subnetworks. The subnetwork then looks more like a complete network, while the logic and computations (note 0.0 duration) have not been altered. (Figure 6)

Figure 6
Work Center Subnetwork

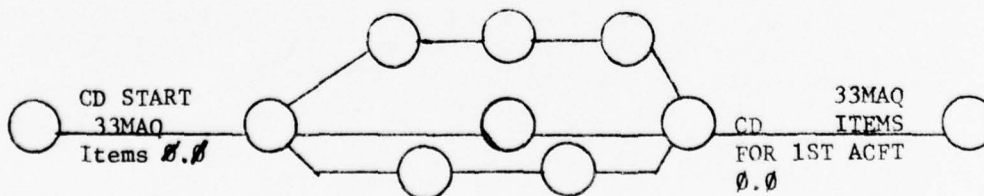

c. The third use of a construction dummy is to include a time "pad" in an activity duration that the CPR insists must be retained. In this example (Figure 7) a two-week "pad" is preserved in the plan. This is to cover the contingency that the mobility exercise might not be successful; therefore, requiring a repeat. The widespread use of this type of dummy in noncontingent situations is discouraged because it may eliminate options for efficient management actions.

Figure 7
Mobility Exercise

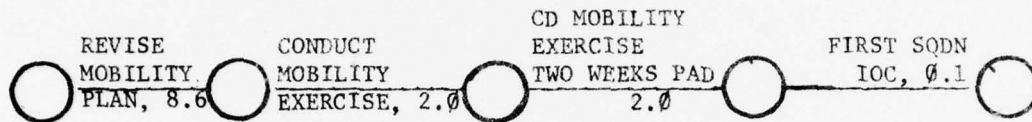

D. Time Estimates

1. Single Estimate. Once the network logic is established, estimates of the activity durations must be made. As mentioned before, TAC PERT uses a single "most likely" time estimate.

2. Unit of Measure. In the examples of this paper, the duration of activities was expressed in weeks and tenths of weeks. However, the choice of a unit for time measurement depends on the scope of the program. For instance, a long-term project covering 5-10 years perhaps should use months or quarters as a unit of time. In contrast, an operations plan covering the deployment of a TAC squadron overseas might use hours and tenths of hours as a unit of time.

3. Obtaining Time Estimates. Time estimates are developed by the same method as is the activity logic, that is, a step-by-step analysis of the activities or tasks that must be accomplished to achieve the program goal.

a. Each activity duration is estimated by someone knowledgeable in the particular functional area. Usually this is the office of primary responsibility (OPR) for this activity.

(1) The time estimate should be "reasonable." That is, the time estimate should be such that the activity could be accomplished comfortably by the OPR within that time.

(2) Bias or "padding" of time estimates must be avoided. Padded estimates give a false impression of the time required to complete the program and also removes management options

for more efficient or effective use of resources. Biased estimates also tend to make those activities appear on the critical path thus unnecessarily invoking concentrated management attention.

(3) Construction Dummies ("CDs") and certain other activities may have a duration of 0.0 weeks, thus consuming no program resources.

b. Once an initial estimate is provided, it is helpful to review the total network. This may reveal errors or the need for further refinement before the preparation of the final working draft of the program network.

c. The effect of resources and weather on activity time estimation may be important. It is best to assume normal manpower, equipment, funds, or other resources except where known changes would occur. Similarly, weather adjustments should be only in those portions of a network which would reasonably be affected. The weather impact should be seasonally adjusted and added to the nominal activity duration. Usually, no compensation should be made for "Acts of God" and similar random and uncontrollable disturbances.

E. PERT Computation.

1. Overall Processing Sequence. Once the program activities, logic, and time estimates have been determined, the result is coded with a unique predecessor and successor event number for each activity and entered into the computer.

a. The first step in the computer execution of PERT is a series of editorial routines to check for format, duplicate activities, loops, and multiple network starts. (Table 1) Usually the specific error is listed and the computer continues processing. A loop is a set of activities that close back on itself. There is no longer a forward progression of time. When a loop is encountered, the computer terminates all further processing.

b. The second execution step is PERT computation of an earliest date, latest date, and slack. The details of these computations are explained below.

c. The final execution step is the creation of the various output products as described in Section III.

Table 1
PERT Editorial Rules

1. Networks may have only one initial event (i.e., with no predecessor) and only one terminal event (i.e., with no successor).
2. No two activities may have the same predecessor and successor event number.
3. Before an activity may begin, all preceding activities must be completed.
4. Loops are not allowed, i.e., the completion of a specific activity (A) cannot be a requirement to start that same activity (A) or preceding activities.

2. Earliest Date Computation. The first computation is a "forward pass" to determine the earliest start and finish dates. Before this may begin, the program must be bounded in time. An initial project event date is selected to be before any activity is undertaken. Frequently this date is when the program is first recognized to be part of an overall command objective.

a. This initial event date, labelled "PERT Start" is an input to the computer processing. This date fixes in time the earliest date any activity can be undertaken. Then the forward pass computation is made for each activity based on the following rules:

(1) The initial project activity is assumed to start at PERT start.

(2) The earliest finish time of an activity is the early start time plus the activity duration.

(3) All subsequent activities are assumed to start immediately after all their predecessor activities are completed.

b. Figure 8 is an example of the forward pass computation. The overall program begins on 1 July 1976. By applying the above rules of logic, both activity 001-584 and 001-306 could begin on 1 July 1976, i.e., this is the early start date for these activities.

(1) Given the respective activity durations (activity 001-584 of 8.6 weeks and activity 001-306 of 17.0 weeks), the earliest these activities could be finished are 1 Sep 76 (event 584) and 1 Nov 76 (event 306).

(2) Continuing the forward pass computation, the earliest dates that activities 584-600 and 306-600 could begin are 1 Sep 76 and 1 Nov 76 respectively. Correspondingly the earliest date the environmental clearance could be approved is 1 Oct 76. In contrast the ECM shop funding would be completed no earlier than 15 Dec 76.

(3) Since the ECM shop invitation for bid (600-601) requires both an environmental clearance and confirmed funding, this activity cannot begin until 15 Dec 76.

Figure 8
Example Forward Pass Computation

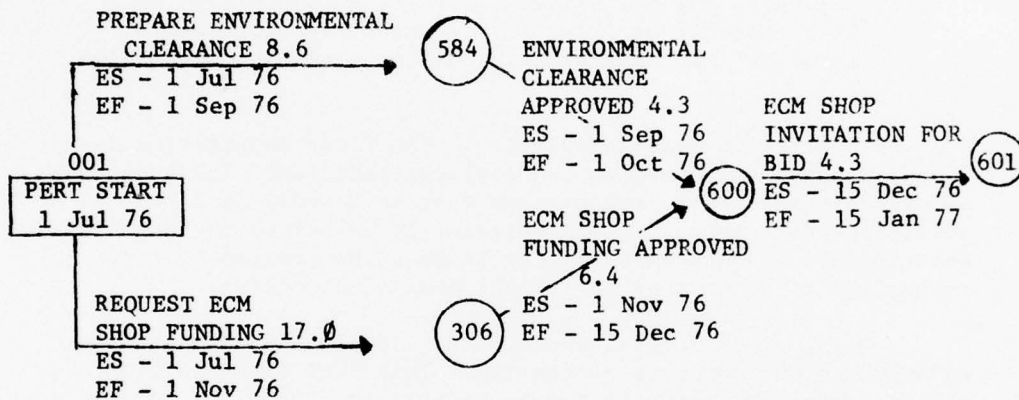

NOTE: a. ES = Early Start
b. EF = Early Finish
c. Activity duration in weeks and tenths.

3. Latest Date Computation. Once the earliest dates are computed for every activity of the network, a "backward pass" is made to compute the latest start and finish dates.

a. The term "latest date" is used in the sense that program completion is delayed if this date is not met. The date of the last program milestone is frequently selected as the end of the program. It is from this program termination date (PERT stop) that the backwards computation through the network is made using the following rules.

(1) Activities are completed as late as possible to meet the program termination date.

(2) The latest finish time for a given activity should be equal (within rounding errors) to the earliest of the latest start times of its successor activities. Computationally latest finish time is set equal to the successor latest finish time less its duration. The earliest of these times is used when there is more than one successor.

(3) The latest start time for a given activity is just the latest finish minus its estimated activity duration.

b. Figure 9 is an example of a backward pass computation. The overall program termination date was determined to be not later than 1 Jan 80 when the last program milestone is completed.

(1) To meet the overall program completion date of 1 Jan 80, activity 8-999 must be started no later than 1 Nov 79, i.e., the latest start date.

(2) Since both activities 7-8 and 5-8 must be completed before the simulator facility can be landscaped, they both must finish not later than 1 Nov 79.

(3) To assure activity completion on time (1 Nov 79), activity 7-8 must start not later than 15 Sep 79 while activity 5-8 must start not later than 1 Aug 79.

(4) Therefore activity 6-7 has a latest start date of 23 Aug 79 and a latest finish date of 15 Sep 79. Similarly, activity 4-5 has a latest start of 1 Jul 79 and a latest finish of 1 Aug 79. Meeting all these milestones assures that the program will be completed exactly on schedule (1 Jan 80).

Figure 9
Example Backward Pass Computation

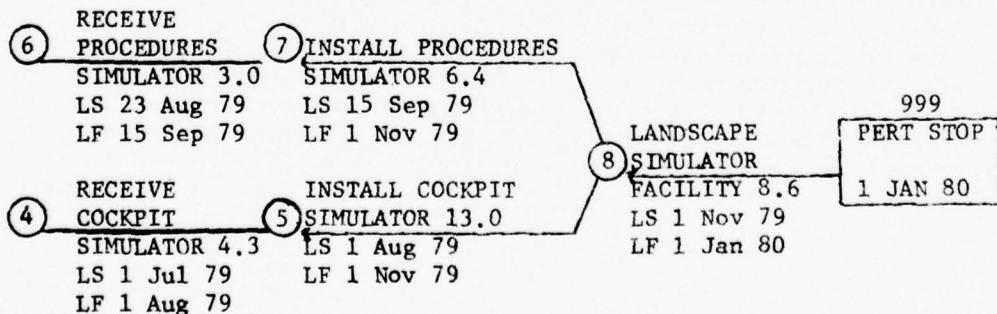

NOTE: a. LS = Latest Start
b. LF = Latest Finish
c. Activity duration in weeks and tenths.

4. Slack. Basic to the effective use of PERT is the concept of slack. Slack, sometimes called float, is the difference in time between the earliest and the latest dates for an activity. The amount of slack on an activity reflects the degree that management attention should be devoted to that activity. The following three paragraphs correspond to slack features highlighted in the section of a TAC PERT listing shown in Figure 10.

a. To obtain the slack value of a given activity, consider the earliest and latest finish dates. The difference between these dates (e.g., 15 Feb 79 and 1 Jan 79) is the slack (6.4 weeks) computed for this activity. Remember that the forward pass that computed the earliest dates and the backward pass that computed the latest dates are independent.

b. Negative slack occurs when the earliest date is later than the latest date. Negative slack means that, assuming the activity time estimates and logic are correct, the program termination will be late by this amount (6.4 weeks). Negative slack activities need immediate and continuing management attention to:

- (1) Monitor the achievement of scheduled milestones,
- (2) To verify the accuracy of the network logic,
- (3) To assure the accuracy of the estimated activity duration, and
- (4) To develop work-arounds to bring the program back on schedule.

c. In contrast, positive slack occurs when the earliest date (forward pass) is prior to the latest date (backward pass). Large amounts of positive slack (25.8 weeks in this example) usually indicate that premium management attention is not required. Positive slack can be viewed as a "savings account" to assure the achievement of the program objective. The "savings account" can be deliberately drawn upon to enhance the smooth execution of the program. However, a reasonable balance is desirable to cover unforeseen contingencies.

Figure 10

Slack Example

START DATES		FINISH DATES		ACTUAL / SCHED	ACTIVITY	SLACK
EARLIEST	LATEST	EARLIEST	LATEST	FINISH TIME		
16JAN79	02DEC78	15FEB79	01JAN79	S31AUG78	4.3	6.4
30MAR79	05FEB79	13APR79	19FEB79	S15JAN79	2.0	7.5
30MAR79	01FEB79	29APR79	03MAR79	S28FEB79	4.3	8.1
07DEC77	06JUN78	05APR78	03OCT78	S05APR78	17.0	25.8
04JAN78	14MAR78	05APR78	13JUN78	S05APR78	13.0	9.8
05JAN78	02NOV78	06MAR78	01JAN79	S06MAR78	8.6	43.0
				A30JAN78		
02FEB78	05MAY78	01OCT78	01JAN79	S01OCT78	34.4	13.1
04FEB78	02NOV78	05APR78	01JAN79	S05APR78	8.6	38.7
				A16FEB78		
				A22FEB78		
05APR78	03OCT78	04JUN78	02DEC78		8.6	25.9
05APR78	02NOV78	04JUN78	01JAN79	S30NOV78	8.6	30.7
JUN78	02DEC78	04JUL78	01JAN79		4.3	25.7
JUN78	04JUL78	25AUG78	02SEP78		8.6	1
JUN78	04SEP78	25SEP78	04DEC78		13.0	1
JUN78	02OCT78	24NOV78	01JAN79		13.0	
JUN78	02NOV78	24OCT78	01JAN79		8.6	
JUN78	01JAN79	24NOV78	02APR79	S28FEB79	13.0	
JUN78	NOV78	24OCT78	01JAN79	S30NOV78		
JUN78	78	24SEP78	02DEC78	S30NOV78		
JUN78	78	24NOV78	02DEC78	S30NOV78		

III. PRODUCT DESCRIPTION.

A. Types of Output Products.

1. Overview. Once the WWMCCS computer processing is finished, output products can be directly obtained as listings or they can be plotted as bar charts, networks, or XY plots. The TAC program management requirement for start dates, in addition to finish dates, led to the creation of specialized PERT listing and bar chart formats.

2. Method of Explanation. Each output product is described in isolation. With each description, an example is provided. The features highlighted in the example correspond, in number, to the narrative paragraph explaining that feature of the product.

B. TAC PERT Output Products

1. TAC PERT Listing. Figure 11 is a page from a TAC PERT computer listing.

a. The original WWMCCS computer PERT program was modified to compute and list start dates for activities thereby creating the "TAC PERT Listing."

(1) The network start date and network completion date bound the program and correspond to the dates used to initialize the forward and backward pass computations, respectively. The slack value listed here is the most critical value to occur in the entire network. The "report as of date" is the date of the last program update. All time prior to this date is history and cannot be used to manage the program.

(2) The total numbers of events (nodes) and activities (lines) in the network are listed here. The "date/time" is when this listing was generated and is completely independent of the "Report as of Date."

(3) There are a total of 10 different sort variables. They are: TASK - task number column, OPR-TAC OPR column, PRED - predecessor event number, SUCC - successor event number, ESTART - earliest start date, LSTART - latest start date, EFINISH - earliest finish date, LFINISH - latest finish date, SLACK - activity slack column, and DCS - first two characters in task number column with a separate page for each two letter office symbol. These may be used singly or in combination. For example, "OPR, LSTART" means that the list of activities is sorted first by TAC OPR and then within each OPR the latest start dates are put into chronological order.

(4) The first three columns on the left of the listing identify responsibilities. The left most column, "TASK Number," is used as a unique identification of the activity. Specific details of the task numbering system are available in Section IV,B,5. In the next column the symbol of the office of primary responsibility is listed. Where a non-TAC agency actually performs the task (here, OOALC), this is shown in the third column with the TAC monitoring agency shown in the second column.

(5) Each activity is given a line of print. The predecessor event number identifies the start of the activity while the successor event number identified the activity completion. Thirty-five spaces are provided to describe the activity. Terminology and abbreviations used to describe the activity must be understood by the person responsible for managing it. Some common abbreviations are provided in Table 2.

Table 2
List of Abbreviations

ACFT - Aircraft	ND - Need Date
ADTN - Additional	NTP - Notice to Proceed
APPR - Approve	OJT - On-the-Job Training
CD - Construction Dummy	OPR - Office of Primary Responsibility
CKLST - Checklist	PREP - Prepare
COORD - Coordinate	PROCED - Procedure
DETER - Determine	PRODCN - Production
DEV - Develop	PUB - Publish
DIST - Distribute	RDY - Ready
ESTAB - Establish	REQ - Request
EVAL - Evaluate	REV - Review
FLT - Flight	RQMTS - Requirements
FTD - Field Training Detachment	RQNTN - Requisition
IAW - In Accordance With	SPT - Support
IDENT - Identify	SUPMT - Supplement
IFB - Invitation For Bid	TECH - Technical
INCORP - Incorporate	TO - Technical Order
LTR - Letter	TRANS - Transfer
MAINT - Maintenance	TRNR - Trainer

(6) In this listing, both scheduled start dates (prefix S) and actual start dates (prefix A) are incorporated. These dates differ in that an actual start date is used in the subsequent computations. Note that the difference between the earliest start date (30 Jan 78) and the earliest finish date (01 May 78) is exactly 13.0 weeks--the activity time.

(7) As with the start dates, provision is made for scheduled finish dates (prefix S). The scheduled finish is computed by adding the activity duration to the scheduled start.

(8) The actual finish date (prefix A) denotes a completed activity. The actual finish date overrides all computed dates and they are blanked out in the TAC PERT listing.

(9) The remaining columns list the activity time and slack associated with the activity. In each column, the times are in weeks and tenths. A blank entry denotes a 0.0 time value.

b. This TAC PERT listing is directly obtainable from the computer and does not require plotter support. Thus it is usually the first product available from a program update. Usually the following three sorts are printed together although other sort options can be requested where appropriate.

(1) An OPR, ESTART sort is used to highlight activities of interest in the next monthly progress report.

(2) A SLACK sort identifies that paths of criticality in the program.

(3) The PRED, SUCC, and SUCC, PRED sorts, together, are frequently used to diagnose changes and correct errors in the network.

2. TAC PERT Bar Chart. A bar chart is a list of activities coupled with a time-phased display of program milestones corresponding to each activity. Figure 12 is an example of a bar chart.

a. The following subparagraphs correspond in number to the numbers annotated on Figure 12.

(1) The heading and title block identifies the PERT program and the address and telephone number of the organization responsible for the program.

(2) A classification banner is provided at the top and bottom of each chart describing the classification of information contained therein. The data date represents "today" in the network logic. Normally this "as of date" corresponds to the last program update.

Figure 12 - TAC PERT Bar Chart

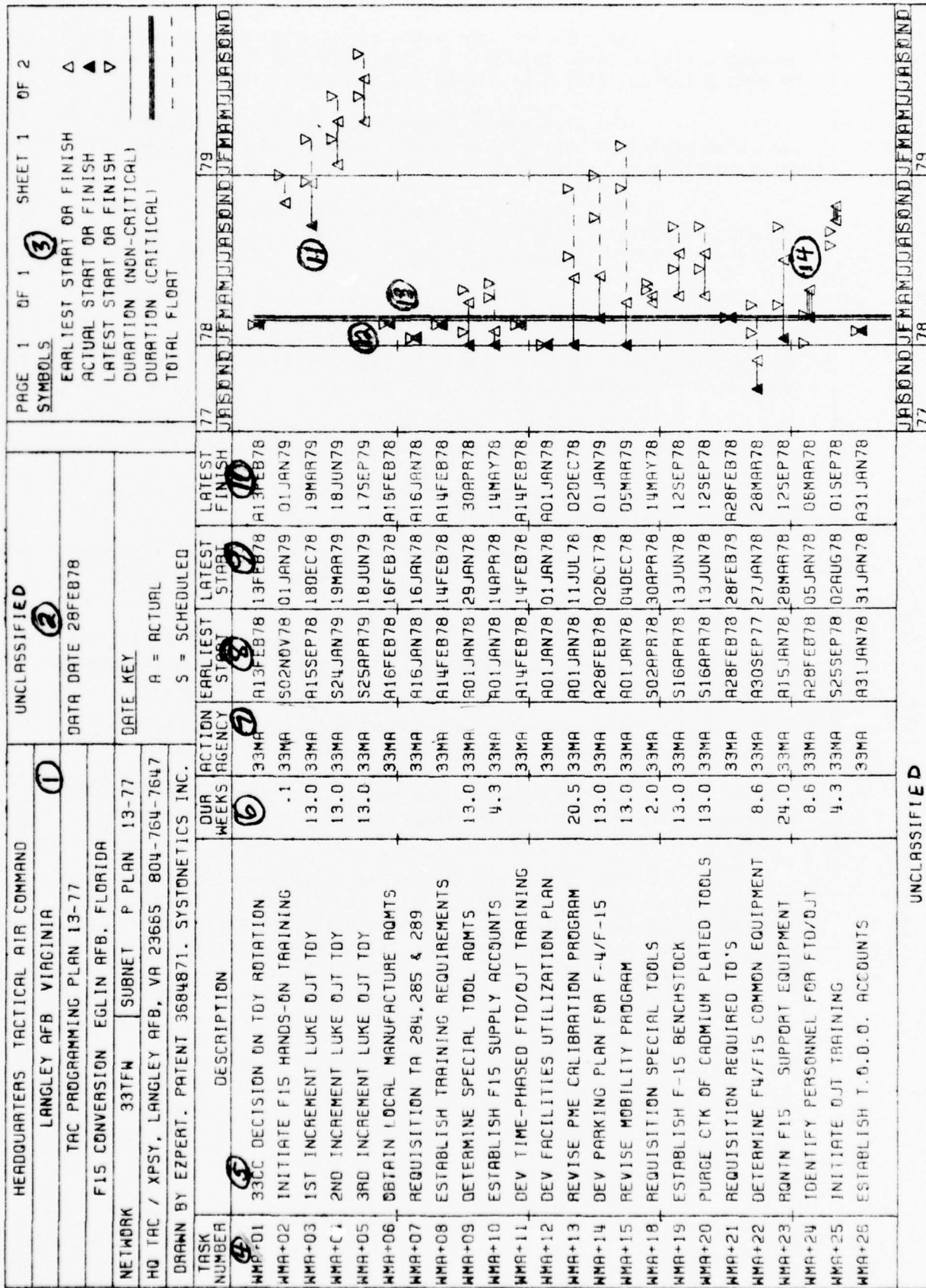

UNCLASSIFIED

(3) The legend block defines the symbols used in the bar chart as well as providing page and sheet numbers. Usually a block of activities are plotted together as bar charts of a stated size. The example is plotted to legal size (8 x 13). This block of activities is further subdivided into pages and/or sheets.

(a) Paging is the horizontal continuation when the time interval is too long (horizontally) to fit a chart of this size.

(b) Sheeting is the vertical continuation when the number of activities is too great (vertically) to fit a chart of this size. In this example, 24 activities are plotted per sheet. In this example, if "33 MA" has 37 activities, 24 are plotted on sheet 1 and the remaining 13 are plotted on sheet 2.

(c) This specific definition of pages and sheets has caused some confusion to PERT users. Figure 13 is an example of a combination of pages and sheets when producing legal size bar charts.

Figure 13
Example Activity Block

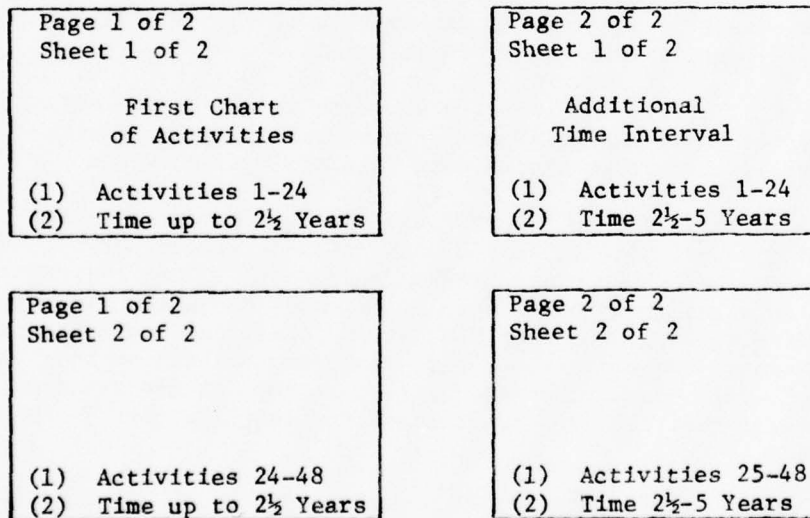

(4) The task number is a 6 character code to identify the activity. The activity is identified uniquely by this number. The coding scheme employed in this column is explained in section IV,B,5,b.

(5) The activity description is a 35 character free-form field. By convention construction dummies have a "CD" in the first two spaces of this field. The abbreviations and nomenclature used to describe the activity must be understood by the action agency responsible for the activity (see Table 2). In general, active verbs (establish, revise, develop, etc.) are preferred to passive verbs (monitor, etc.) in these descriptions.

(6) This column displays the activity duration in weeks and tenths. A blank entry corresponds to a 0.0 duration or a completed activity. 4.3 weeks is a 30-day month.

(7) The action agency is the office actually responsible for accomplishing the stated activity or is the primary link to a non-TAC agency accomplishing the activity. A total of 6 spaces are provided to properly identify the agency. In this example, "33 MA" is the office symbol of the Deputy Commander for Maintenance for the 33d Tactical Fighter Wing.

(8) The earliest start date is the earliest date an activity may begin. This date is determined by the forward pass computation. An "S" prefix denotes a start date scheduled by the action agency and replaces the computed earliest start date. The "A" prefix denotes an actual start date for the activity. When an actual start is inserted it replaces the computed earliest start date and is used in subsequent computations.

(9) The latest start date is the latest date the activity may begin and still meet the overall program objectives. This date is the latest finish date less activity duration.

(10) The latest finish date is produced by the backward pass. This date is the completion date needed for this activity to meet the overall program objectives. The "A" prefix denotes an actual completion date supplied by the user. The actual finish date replaces the computed latest finish date in subsequent computations. The plotter software has been modified so that an actual activity completion date will cause the "earliest start" and "latest start" columns to be blank for that activity in the bar chart.

(11) This is the bar chart depiction of an activity schedule with an actual start (solid triangle) and positive slack (dashed line). The earliest (actual for this example) start and finish are upright triangles with the apex corresponding to the date on the time line. The latest start and finish are inverted triangles with apexes corresponding to the date on the time line. A solid line connects the earliest start and finish and has a length equal to the activity duration.

(12) This is a bar chart depiction of a completed activity.

(13) The three vertical lines denote "today" with respect to computer logic and equal the data date.

(14) This is a bar chart depiction of an activity with negative slack. The latest start (5 Jan 78) comes before the earliest or actual start (28 Feb 78). The 3-horizontal lines serve to highlight activities with negative slack.

3. Network. Another PERT display is a network. A network emphasizes the logic relationships between activities as well as their time phasing. Activities which may be done concurrently are displayed on parallel lines. Dependencies between activities are shown as lines emerging from or converging to the appropriate event blocks. Usually the length and direction of the line have no meaning except to connect two events with reasonable plotter efficiency.

a. Figure 14 is an example of a network legend block. The single diagonal line highlights event blocks with a scheduled date. The crossed diagonals highlight actual activity completions.

(1) A octagonal block denotes a start or end point in the network being displayed. Every network will have at least two of these blocks. The octagonal blocks may also show the interconnection between two or more network panels of a given program. The TAC plotter paper has a maximum useable width of 21 inches. Depending on character size, this allows a maximum of 72 parallel activities to be displayed as a single network panel. Large programs use multiple panels.

(2) A rectangular block is used to denote events or nodes between the network start and end blocks. The additional types of blocks are available in EZ PERT but are not used in TAC PERT.

(3) Below the legend is a network title block. This area provides for program identification, data date, classification as well as the address and telephone number of the responsible organization.

b. Figure 15 is a portion of a network depicting the 33 TFW intelligence activities. The following subparagraphs correspond to the circled numbers in the figure.

(1) A date line is provided at the top and bottom margin to place activities in time perspective. The latest finish date is used most often to place the activity with regard to date line. The dashed vertical lines highlight major program milestones at 1 Apr 78 and 15 Dec 78.

Figure 14 - Network Legend









	EXPECTED	SCHEDULED	ACTUAL
SPEC. INT.			
END/START ①			
INTERFACE			
SPECIAL			
NORMAL ②			
HEADQUARTERS TACTICAL AIR COMMAND			
LANGLEY AFB VIRGINIA			
③	TAC PROGRAMMING PLAN 13-77		
F15 CONVERSION EGLIN AFB, FLORIDA			
NETWORK	33TFW	SUBNET PPLAN 13-77	
HQ TAC / XPSY, LANGLEY AFB, VA 23665 804-764-7647			
UNCLASSIFIED		DATA DATE 28FEB78	
DRAWN BY EZPERT. PATENT 3684871. SYSTONETICS INC.			

Figure 15 - Example Network

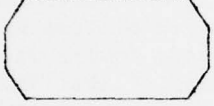

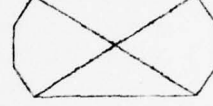
(2) In this example five activities branch from a common event (numbered 093000). These five activities may be done concurrently and are thus shown one over the other (parallel). A 45° angle in the line is used to show concurrent activities branching from a single point.

(3) Three of the activities terminate outside of this portion of the total network as shown by the octagonal blocks.

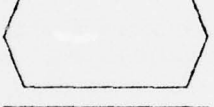
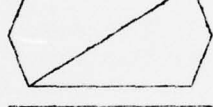
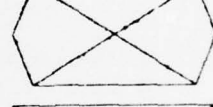
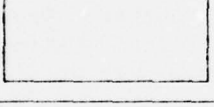
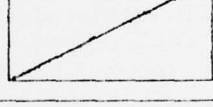
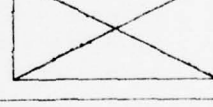
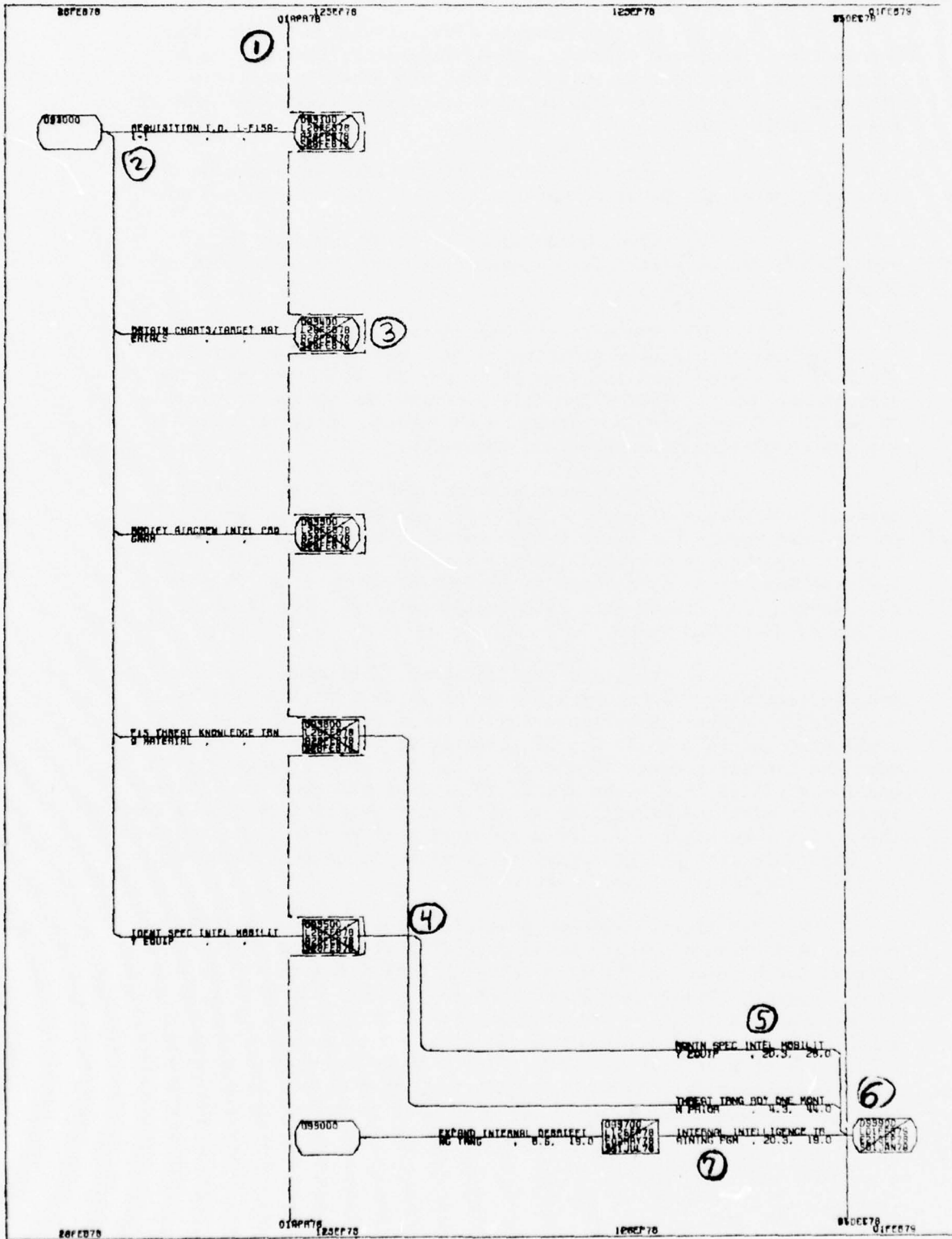
(4) Lines which cross at a 90° imply no logic connection. In this case, the lines cross only for appearance purposes.

(5) The activity description (Rqntn Spec Intel Mobility Equip), activity duration of 20.3 weeks, and positive slack of 28.0 weeks are the same as in the TAC PERT listing. The predecessor event (093500) for this activity was completed on 28 Feb 78. Completion is denoted by the crossed diagonal lines and the completion date is put in the block.

(6) The successor event (093900) is scheduled, denoted by a single diagonal line, to be completed on 1 Jan 78. On the next update the event 093900 would be shown as complete only if all three activities leading into it are completed. The earliest date this could occur is 21 Sep 78, i.e., 2 May 78 plus 20.3 weeks. The latest date this could occur is 1 Feb 79, i.e., 12 Sep 78 plus 20.3 weeks.

(7) Consider the "internal intelligence training program" activity. It could start as early as 2 May 78 then 20.3 weeks later produce an earliest finish of 21 Sep 78. However, it could start as late as 12 Sep 78 (completing on 1 Feb 79) and still meet the overall program objectives. The difference between 2 May 79 and 12 Sep 78 is 19.0 weeks slack. The OPR considered the activity in context with the overall Eglin AFB F-15 conversion when he scheduled the activity to start 1 Jul 78 and complete 1 Jan 79. This schedule is compatible with the PERT analysis because it falls between the earliest and latest allowed dates.

4. X-Y Plots. Another possible output of the TAC PERT system is a graph of almost any data. With respect to PERT, a program has been constructed to take all activities in a PERT data base, separate them by two letter OPR (33, 12 AF, DO, DE, etc.) and compute which activities are on-going as of the first of a given month. The result describes the number of on-going activities as a function of time for that OPR. Figure 16 is an example showing the total number of conversion activities on-going at the 33 TFW as of the first of the month. The principal features are listed below:

a. The two letter OPR symbol is left justified in the title line. The rest of the title line comes from the setup instructions and is the same for computer listings and bar charts.

b. The vertical scale is automatically adjusted so that the highest data point is greater than halfway but remains on an 8 x 10½ inch sheet.

c. For each month a symbol is plotted, the plot line merely connects the symbols (triangles).

d. As with the vertical axis, the horizontal axis is automatically adjusted to provide efficient use of the 8 x 10½ sheet. The bold vertical line corresponds to the "report date" of the computer listing and the "data date" of the bar chart.

IV. TAC PERT STANDARDIZATIONS

A. Overview. The expected frequency of use led to the standardization of certain features in the TAC PERT. The features include the coding of certain columns, a method of slack analysis, and a method of updating the program.

B. Standardized Coding. The computer support associated with PERT provides considerable freedom in actually implementing a specific PERT. However, a portion of this freedom was traded in TAC PERT for commonality between programs. These common features are described below.

1. Numbering Key Events. Each of the aircraft conversion programs appeared to have several major milestones in common. This characteristic was incorporated in TAC PERT by assigning a special meaning to certain (but not all) event numbers.

Table 3 lists these standard event numbers. For example, the event number "300000" means the arrival of the first new aircraft (unit equipment, not a hands-on trainer) regardless of the particular aircraft conversion PERT under study.

2. Event Number Assignment By Work Center. As the specific details of a work center were inserted into the PERT, a quick way to associate the activities with a given OPR was needed.

a. Thus the event numbers not listed in Table 3 were blocked off by the OPR. Figure 17 illustrates this partitioning for the 33 TFW PERT.

FIGURE 17

BASE DETAIL IMPLEMENTATION

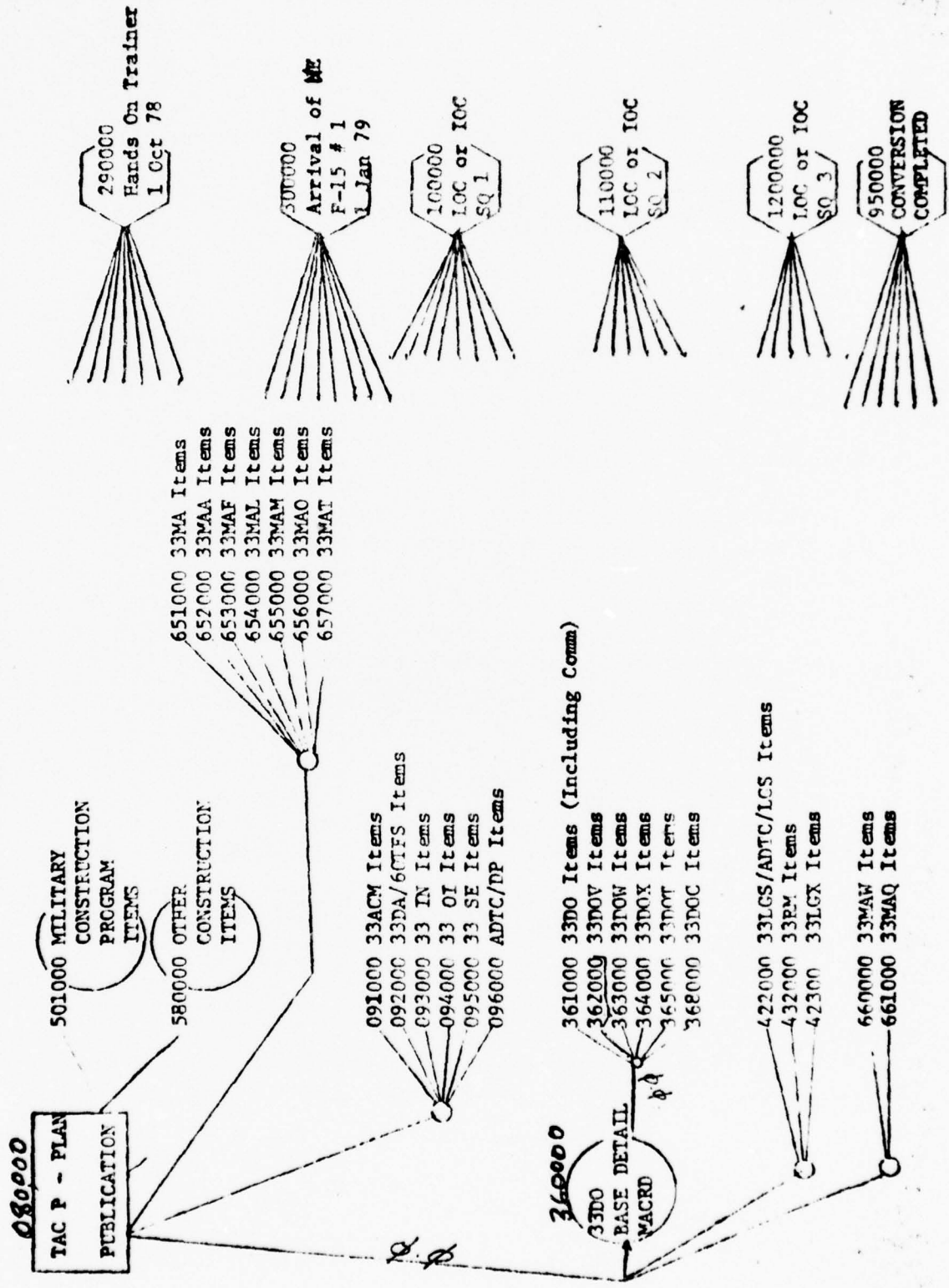

b. Construction dummies were used to connect the major program milestones with the partitioned event numbers. As shown in Figure 18, this method resulted in a more refined appearance when producing a subnetwork plot for an individual work center. The construction dummy was used to identify the OPR and the activities which could start with TAC P-Plan publication (event 080,000). The completion of these activities is tied to the appropriate milestones illustrated on the right side of Figure 17.

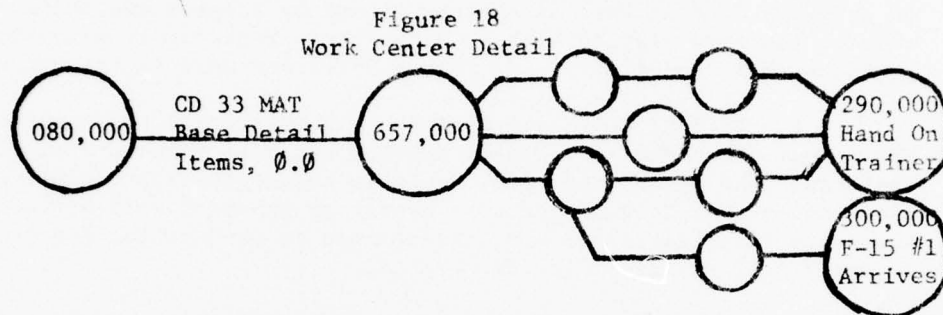

c. This method placed similar activities together in the predecessor/successor computer listing and provided a coherent number system accommodation activity growth within the work center.

Table 4
Example Data Source Code

CODE

- X - Initial PERT construction based upon:
 - a. XPPC letter of 31 August 1977, Subject: TAC P-Plan 13-77.
 - b. Aircraft flow worksheets from DOOT, copies 26 August 77 and rechecked 20 September 1977.
 - c. Eglin AFB, construction from DEPR "Smart Book" as of 6 September 1977.
 - d. TAC Programming Plan 12-76, 10 September 1976, Subject: Maverick.
 - e. TAC Programming Plan 1-77, 17 March 1977, Subject: POMO Implementation.
- A - 33 TFW F-15 Conversion TEAM Planning, 15 September 1977.
- B - USAF/PRP Secret message, 211445Z September 1977, Subject: READY TEAM.
- C - Telecon on 23 Sep 77 between Mr. Ben, TAC/DEPR, and Mr. Ed, TAC/XPSY, concerning Eglin O&M construction.
- D - Base Detail Implementation with TAC/ACMX (Capt _____) assisting. Included are proposed TDY/PCS overmanning data from 3 October 1977 TAC/LGX, LGM, DPX, XPM meeting on that subject.
- E - Base Detail Update from 12-16 October 1977 TDY to 33 TFW.
- F - Addition of ESS (Electronic Standards Set) items from 9 AF.
- G - Addition of 33 MAQ items received 4 November 1977.
- H - Changes resulting from the 14-16 November 1977 SATAF including a Civil Engineering update.
- I - Addition of Headquarters/DO time-phased actions for TAC/DO, 9 AF, 12 AF, 33 TFW, and 58 TTW. This is the last update code prior to P-Plan 13-77 publication.

3. Data Source Coding. Information pertaining to an aircraft conversion program comes from numerous sources both in and out of the command. Since a function of PERT is to integrate this information into a single data base, there is value in being able to take the PERT analysis and go back to the input data source. Table 4 is an example data source code implemented to track the source of activity data as well as changes caused by program execution. In effect, the code coupled with an appropriate backup filing system provides this capability. See Figure 20(c) for data source coding.

4. EZ PERT Selection Options. The elaborate task numbering/OPR format described in the next section exploits some EZ PERT plotter features. The predominant feature is to select the appropriate activities that belong to a single work center or group of work centers. Figure 19 illustrates the plotter commands to produce two blocks of activities as legal size bar charts.

Figure 19
EZ PERT Plotter Commands

```
/TSCALE(MONTH)
,TPAGE(JAN,48)
,SIZE=15.9,CHARACTER=0.18
,CRITICAL=0.0,FACTOR=0.45
,SPOS=1,$SELECT(58)
,NOTE='P PLAN 13-77 UNCLASSIFIED '
```

```
/TSCALE(MONTH)
,TPAGE(JAN,48)
,SIZE=15.9,CHARACTER=0.18
,CRITICAL=0.0,FACTOR=0.45
,SPOS=8,$SELECT(DOOT)
,NOTE='P PLAN 13-77 UNCLASSIFIED '
```

a. The command "/TSCALE" defines the beginning of an activity block and specifies the bar chart time scale. TPAGE fixes the horizontal bar chart size. The bar chart would begin in January and cover 48 months. The size, character, and factor commands establish the vertical bar chart size. The CRITICAL command assures that negative slack activities are highlighted.

b. The "SPOS = 1, SELECT (58)" command actually specifies the activities to be plotted in terms of the TAC PERT listing which is stored on a file in the computer.

(1) The "SPOS" command designates the column in the TAC PERT listing for selection. "SPOS = 1" means the selection criteria begins in the first space of the Task Number column (Ref Figure 11). A SPOS = 8" means the selection criteria begins in the first space of the TAC OPR column. A "SPOS = 15" means the selection criteria begins in the first space of the Action Agency column.

(2) The "SELECT (58)" command picks those activities containing a "58" beginning in the column specified by SPOS. The desired contents must be exactly as described in the TAC PERT listing except for the following special characters. In a SELECT command a "\$" denotes a blank in the listing and a "*" denotes all other entries not previously selected from the listing.

(3) Now that the desired activities have been selected, the classification banner must be added. The NOTE command first sets the subnet title (first 15 spaces). The example here is "P PLAN 13-77." Then the contents from spaces 18-29 of the NOTE command actually constitute the classification banner. (i.e., UNCLASSIFIED).

5. Task Number/OPR Format. PERT in effect supplies an integrated view of the program explicitly identifying activity relationships at all levels of management. While the entire program must be assessed as a whole, activities need to be displayed by organization entities with delegated authority and responsibilities. To achieve this goal a scheme of task numbering of both reportable and nonreportable activities was developed.

a. The TAC PERT listing provides 18 spaces for this use. These spaces have been subdivided as distinct columns in the listing: TASK NUMBER (6 spaces), TAC OPR (6 spaces), ACTION AGENCY (6 spaces).

b. The purpose of a task number code is to uniquely identify each activity and to group related activities along organizational lines. The coding should clearly differentiate activities between Annex Z progress reporting (if applicable) and PERT update submissions. The assignment of numbers will be unique within each OPR. A "b" in the following discussion denotes a blank.

(1) When the PERT program was used to publish the Annex Z, Time-Phase Actions, in a Programming Plan, the following codes were used: The "+" or the "W" denote those activities requiring progress reporting under Annex Z.

(a) Two letter HQ TAC OPR.

<u>TASK NUMBER</u>	<u>TAC OPR</u>	<u>ACTION AGENCY</u>
LGb+23	LGMFbb	Blank
LGb+24	LGWSbb	Blank

(b) Three letter HQ TAC OPR.

XPM+04	XPMXbb	Blank
XPM+05	XPMQbb	Blank

(c) Two letter numbered Air Force (N prefix) OPR.

NDO+02	DOOTbb	9DOOb
NDO+22	DOVbbb	12DOV

The task numbers are blocked between 9 AF (less than 20) and 12 AF (greater than 20).

(d) Two letter wing OPR (W prefix)

WDO+16	DOOT	Blank
WRM+41	DEPR	ADTCb

The task numbers using these codes will correspond to previously non-TAC participation and/or accomplishment of the activity.

(e) Three letter wing OPR (W prefix). In this case, the "+" has been dropped to allow a three letter office symbol and two digits of task numbers within the six available spaces.

WDOV03	DOVbbb	Blank
WMAA04	LGMF15	Blank

(f) The coding of special agencies (such as activation of a new squadron) will be tailored to each PERT.

(2) When a manually developed Annex Z was published, the following codes were used:

(a) Headquarters items replace the "+" with a blank.

LBbb54	LGMMbb	Blank
XPMb51	XPMMbb	USAFb

(b) Numbered air forces likewise replace the "+" with a blank.

NDOb53	Blank	9DOVb
NCSM58	Blank	9CSMb

(c) Wing detail will have a prefix "B" and the TAC OPR will be blank. The number sequence should start at 50 where possible so as to preclude reporting confusion.

BMAb53	Blank	Blank
BRMb63	Blank	6OTFS
BLGX69	Blank	ADTCb
BLGX70	Blank	OOALC

(d) Construction dummies will have a prefix "Z" followed by a three letter OPR. This coding enhances subnetwork displays by OPR.

6. PERT Input Format. Figure 20 is an example of the input format of PERT incorporating all the preceding codes. The following paragraphs correspond in number to the highlighted elements of Figure 20.

Figure 20
PERT Input Format

DATE 04-25-7E

UNCLASSIFIED

(a)	(b)	(c)	(d)	(e)	(f)	(g)	(h)	(i)	(j)
654100654200	NC1120770020						33MAL	(2) 5	COMPILE HDST/TENNANT CHANGE ITEMS
654200654300	MC1210770030	WLGX01	33LGX	LGXP					REQUEST ADTC CONVENE REVIEW BOARD
654500654590	ES0331780043	WLGX02	33LGX	LGXP					SUBMIT CHANGED HTSA TO 9AF/LGX
654590654600	E 0020		9AF/LG	5					SUBMIT CHANGED HTSA TO TAC/LGX
654400654490	H 0020		33LGX	5					SUBMIT UNRESOLVD HTSA ITEMS TO 9AF
080000185000	IS0301780043	NDD+21	12AF	/DDO					IDENTIFY OPERATIONS PGM MANAGER
185000186000	IS0501780086	NDD+22	12AF	/DDO					ESTAB 33-9-12-5P COMMUNICATIONS
186000950000	NS0815780520	NDD+23	12AF	/DDO					MONITOR EGLIN AIRCREW TRAINING
186000330000	NS0815780390	NDD+24	12AF	/DDO					INFORM 9AF/DDO ON TRAINING MATTER
186000160000	IS1008780010	NDD+25	12AF	/DDO					COORD MSN QUAL LTR OF AGREEMENT
651100330000	I 0130		9AF/LG	5					ASSIST IN REVISING MOBILITY PLANS
080000180000	IS0301780043	NDD+01	9AF/DO	5					IDENTIFY OPERATIONS PGM MANAGER
180000181000	IS0501780086	NDD+02	9AF/DO	5					ESTAB 33-9-12-5B COMMUNICATIONS
181000363720	IS0801780086	NDD+03	9AF/DO	5					ESTAB DART TOW SPT PROCEDURES
181000950000	I 0520	NDD+04	9AF/DO	5					SOURCE DACT SPT FOR MSN QUAL TRNG
180000950000	I 0520	NDD+06	9AF/DO	5					MONITOR EGLIN AIRCREW TRAINING
180000367100	I 0086	NDD+07	9AF/DO	5					INSURE 33PD RETAINS MAX READINESS
365500165000	IS1017780020	NDD+05	9AF/DO	5					APPROVE MSN QUAL LTR OF AGREEMENT
165000300000	IS1101780086		DDOT	L5					LTR OF AGREEMENT 2 MONTHS PRIOR
654490654700	E 0020		9AF/LG	5					SUBMIT UNRESOLVED ITEMS TO TAC/LG
656511300000	D 0043		33MAD	5					IDENTIFY FTD/OJT PERSONNEL
656622290000	ES0701780130		33MAD	5					REQUISITION & FILL BENCHSTOCK
656623290000	ES0701780130		33MAD	N 5					MONITOR RECEIPT OF SUPPORT EQUIP
656000656100	NA0215780020		33MAD	5					ESTAB 33MAD MANAGEMENT GOALS
656000656110	NA0104780390		33MAD	N 5					DEV OVERLAP FACILITIES USE PLAN
656100656300	NA0118780043		33MAD	5					ESTABLISH SUPPLY REQUIREMENTS

a. Predecessor Event Number. A 6 digit numeric column to specify the beginning point of the activity. A blank is forbidden.

b. Successor Event Number. A 6 digit numeric column to specify the completion point of the activity. A blank is forbidden.

c. Data Update Code. A one digit alpha numeric-entry to identify the source of the last information on this activity.

d. Data Code. A one digit alphabetic entry to specify what kind of date follows: "A" denotes an actual start of the activity, "C" denotes the actual completion of the activity, "S" denotes a scheduled start date.

e. Date. A 6 digit numeric column to enter a date of importance to this activity. The format is "mmddyy" where "112077" means 20 Nov 1977.

f. Activity Duration. The time needed to accomplish the activity (weeks and tenths in this example). "0020" corresponds to 2.0 weeks.

g. Task Number. A 6 digit column to specify reportable or nonreportable tasking. See Section IV,B,5 for an explanation of these codes.

h. TAC OPR. A 6 digit alphanumeric column to identify the agency within the Tactical Air Command actually responsible for accomplishing this activity.

i. Action Agency. A 6 digit alpha numeric column suitable for further codes for TAC actions or to identify an outside OPR (OOALC, AFLC, USAF, ADTC, etc.) where needed.

j. Activity Description. Beginning in column 46, 35 spaces are provided to identify the task actually being undertaken. Nomenclature and abbreviations should be those familiar to the agency accomplishing the activity.

C. Slack Analysis. Basic to the use of PERT is the management of slack. Each activity has a slack value computed as the difference between the earliest date and the latest date the activity may start (or finish). Slack may be positive, negative, or zero.

1. Critical Path. The program as a whole has a "critical slack" defined to be the minimum of the activity slack values. The set of activities that cause the critical slack is called the critical path and comprise the longest time path through the network from PERT start to PERT stop. Time compression must be achieved along the critical path if an overall program time reduction is to be achieved.

2. Slack Management. Slack then is a measure of the ability of the program to be completed on schedule. Positive slack indicates how much each activity may slip and still meet its scheduled completion. Negative slack indicates how much the overall program must be compressed to meet the scheduled completion dates. Slack can be viewed somewhat like a savings account.

a. Positive Slack. Large amounts of positive slack, (8.6 weeks or more) usually indicate that premium management attention to this activity is not required.

(1) The manager is conscious of his "savings account" balance and seeks to preserve it. His concern, therefore, is to start activities on the earliest start date, where this date is reasonable.

(2) If the earliest start date is unnaturally early, the manager should question why as a way to ferret out other unidentified activities and constraints.

(3) However, a manager in concert with the OPR may intentionally schedule an activity to start on a date between the earliest and latest dates. In effect, the manager is drawing upon this "savings account" and allocating it in a conscious way. PERT provides this latitude to sensibly manage workload or to consider morale (Christmas) and other outside constraints.

b. Negative Slack. When an activity has negative slack, it deserves immediate attention to examine one or more of the following:

- (1) Insure the logic is correct.
- (2) Insure the activity duration is correct,
- (3) Develop/use workaround procedures, and
- (4) Insure the activity is started at the earliest opportunity.

3. Slack Computer Listing. A TAC PERT computer listing sorted by slack is a beneficial product to examine overall program timeliness. As shown in Figure 21, activities are listed by decreasing criticality of their slack values.

a. The first 11 activities all have the same slack (-6.8 weeks) and comprise the most critical path through the network.

b. For each set of activities having a given level of slack, the first step of slack analysis is to manually sketch out the logic of these activities. Use a sheet of paper and tie the activities together by predecessor and successor event numbers.

c. Once this subnetwork logic is sketched out, then consider the following:

- (1) Is the logic right?
- (2) Are the activity durations correct?

TASK NUMBER	TAC DPR	ACTION AGENCY	PRED EVENT	SUCC EVENT	ACTIVITY DESCRIPTION	ACTUAL / SCHED START	START DATES EARLIEST LATEST	FINISH DATES EARLIEST LATEST	ACTUAL / SCHED FINISH	ACTIVITY TIME	SLACK
LG5 08 LG5E			000405	000435	CD LOCAL MANUFACTURE SUPPORT EQUIP					- 34.6	
LG5 02 LG5E			000418	000419	DEV NON-WSTA EQUIP LIST MOBILITY					4.3	65.0
LG5 38 LG5F		00ALC	000317	000435	MONITOR POL STOCKAGE/ISSUES		01APR78 30JUN79	01MAY78 30JUL79		10.0	27.9
LG5 10 LG5S			000416	000416	PUBLISH SUPPLY GUIDANCE		01MAY78 29DEC77	09AUG78 09MAR78		26.0	34.6
LG5 11 LG5S			000414	000435	CD SUPPLY GUIDANCE		06NOV78 08SEP77	06NOV78 09MAR78		- 34.6	
LG5 03 LG5M			000860	000418	CD WSTA AVAILABLE		06NOV78 09MAR78	06NOV78 09MAR78			
LG5 04 LG5M			001000	000860	TABLE OF ALLOWANCE-316 AVAILABLE						
LG5 01 LG5M		00ALC	000415	000413	START SUPPORT EQUIP PROG-CD/3-ALC		30JAN78 02JUN77	01MAY78 01SEP77		13.0	34.6
LG5 12 LG5M		00ALC	001000	000199	AFIC DEVELOP/AGGREGATE ISSL		31OCT78 09AUG77	01MAY78 07FEB78		26.0	11.8
LG5 37 LG5M		00ALC	000413	000416	ESTABLISH SE AUTHORIZATION-EAID		01MAY78 01SEP77	08MAY78 08SEP77		1.0	34.6
LG5 36 LG5M		00ALC	000435	000329	HOLD WRK SELECTION CONFERENCE						
LG5 34 LG5M		00ALC	001000	000495	CD START WRK						
LG5 13 LG5M			000529	000573	DEVELOP WRK LIST AFIC DPR						
LG5 14 LG5M		00ALC	000573	000572	WRK LIST AVAILABLE TO RAJCOM						
LG5 39 LG5M		00ALC	000199	000471	REQUEST ISSL-00ALC						
LG5 16 LG5M			000471	000308	APPROVE ISSL						
LG5 41 LG5M		00ALC	000416	000431	CD ME/SE/TA FILL RATES						
LG5 44 LG5M		00ALC	000431	000366	CD REPORT AGETA FILL RATE						
LG5 40 LG5M		00ALC	000866	000435	REPORT WSTA/AGE FILL RATE TO TAC		01JUL78	08MAY78 15MAY78	09MAR78	1.0	9.6
LG5 43 LG5M		00ALC	000416	000335	REQUISITION/MONITOR SE/ME REQMTS		01JUL78	07MAY78 09MAY78	08MAR78	1.1	8.8
LG5 15 LG5M			000413	000435	DETERMINE SUPPLY EQUIP SHORTFALL		01MAY78 08MAR78	02MAY78 09MAR78	02JUL78	1.1	7.7
LG5 18 LG5M			000335	000435	OBTAIN FILL RATE OF WSTA/AGE		01JUL78	08MAY78 09MAY78	09MAR78	1.1	8.8
LG5 09 LG5M			000631	000335	CD WSTA FILL RATE						
LG5 19 LG5M			000308	000489	PROVIDE ISSL TO 00-ALC/DSS		26JUN78 05APR78	07JUL78 16APR78		1.5	11.8
LG5 45 LG5M		00ALC	000489	000309	REPORT ISSL FILL RATE TO TAC		07JUL78 16APR78	14JUL78 23APR78	08OCT78	1.0	11.8
LG5 46 LG5M		00ALC	000447	000447	LOAD+REQUISITION ISSL HILL DPR		01OCT78	19APR78 23APR78	05OCT78	1.5	11.8
LG5 47 LG5M		00ALC	000447	000341	LOAD+REQUISITION BENCH STOCK		07JUL78 23APR78	29JUL78 07MAY78	05OCT78	2.0	11.8
LG5 48 LG5M		00ALC	000341	000498	MONITOR BENCH STOCK RECEIPT		01OCT78	29JUL78 28AUG78	06JUN78	4.3	11.8
LG5 49 LG5M		00ALC	000447	000498	LOAD SUPPLY POINT REQUIREMENTS		15JUL78 23MAY78	29JUL78 06JUN78	05OCT78	2.0	11.8
LG5 20 LG5M			000498	000499	MONITOR RECEIPT OF SPARES		01OCT78	29NOV78 04SEP78	03NOV78	1.1	12.2
LG5 21 LG5M			000499	002600	CD RECEIPT OF SPARES						
LG5 22 LG5M			000531	000332	VERIFY WRK FUNDING		30NOV78 05SEP78	30NOV78 05SEP78			
LG5 23 LG5M			000531	000532	VERIFY WRK FUNDING		01MAY78 11OCT78	02MAY78 12OCT78		1.1	25.3
LG5 24 LG5M			001000	000531	CD START WRK FUNDING						
LG5 25 LG5M			000532	000572	WRK FUNDS APPROVED 2YRS PRIOR IOC		01MAY78 12OCT78	28DEC79 09JUN80	28FEB80	86.5	23.3
LG5 30 LG5M		00ALC	000572	000733	REQUEST 2ND WRK DECK		29DEC79 08JUN80	11MAR80 21AUG80	28FEB80	10.5	23.3
LG5 26 LG5M			000572	000533	REQUEST 1ST WRK DECK		29DEC79 21JUN80	01JAN80 21JUN80	28FEB80	1.0	24.6
LG5 27 LG5M			000533	000534	PROVIDE 1ST WRK DECK		01JAN80 21JUN80	08JAN80 28JUN80	29MAY80	1.0	24.6
LG5 29 LG5M		00ALC	000534	000535	LOAD + REQUISITION WRK 1ST		07JAN80 27JUN80	11JAN80 01JUL80	01APR80	1.5	24.6

④ SORTED BY OPRLSTARI
 ⑤
 ⑥
 ⑦
 ⑧
 ⑨

(3) Can workaround procedures be developed and used to compress any of the activities?

(4) What is the earliest date the activity could reasonably be started?

These 11 activities were reviewed individually with the OPRs. It was determined that activity 664300-140000 was in error. The dual load certification duration (42.3 weeks) is too long and should be revised to 30.0 weeks. This change in duration eliminates the negative slack on this path alone.

d. Once this change in duration is made to the PERT, a revised slack listing will be produced which will reveal a new critical path. The above analysis process is repeated to determine the cause of any negative slack.

e. The underlying motive of this slack analysis is to discover whether a given slack path is in fact a program constraint or is created by the plan itself so that appropriate management action can be taken. If the cause of negative slack is in fact a program constraint, then the above analysis method can identify action to alleviate this constraint.

D. Program Update. PERT allows the repeated evaluation of the program as activities are executed. The basic measure of merit is program slack. There are three levels of program update corresponding to the degree of program change. A single line format is used to incorporate update information in the TAC-PERT data base.

1. PERT Update.

(a) The first level of update occurs within the work center as individuals are assigned to accomplish individual activities. The PERT charts or listings should be kept up to date by writing actual start and completion dates directly on the chart or listing.

(b) The annotated charts in the work center provide the information input to the next update level. Periodically, each work center provides this information to the unit program manager for input into the TAC PERT data base. The result of this process is a set of updated TAC PERT output products for display within the work center. The updated charts should be produced often enough to prevent a cluttered management tool with handwritten notes.

Figure 22

PERT Update and Execution

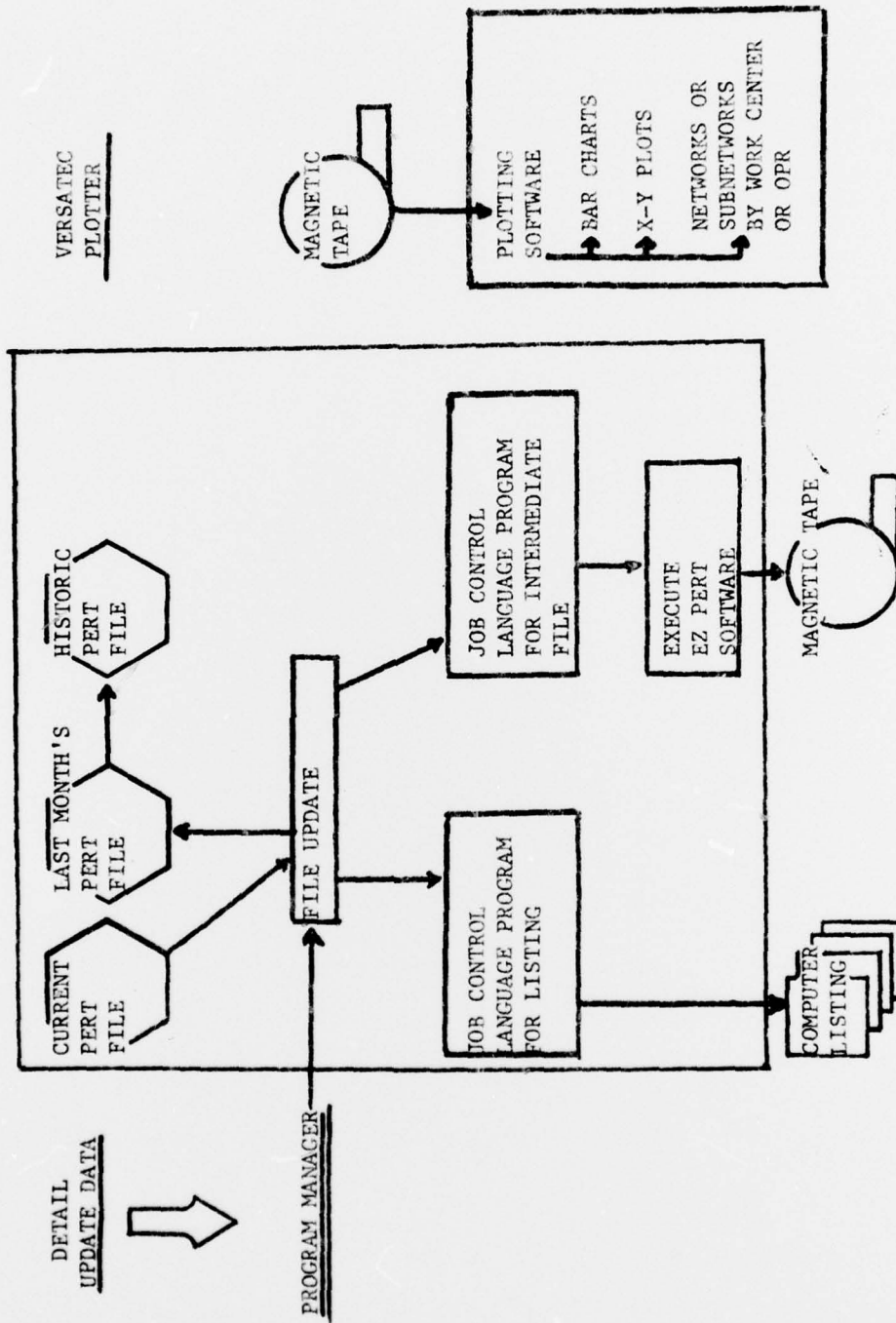

BIBLIOGRAPHY

1. AFSC Report, USAF PERT, Vols 1 and 2, HQ AFSC/AC, Sep 1963.
2. Bursk, Edward C., and John F. Chapman, New Decision-Making Tools for Managers, Harvard University Press, Cambridge, MA 02138, 1963.
3. EZ-PERT Project Graphics, EZ-PERT Reference Manual, ENI with Installation Addendum, D407-1181, Systonetics, Inc., Anaheim, CA 92801, 18 Oct 1976.
4. Fulkerson, "Expected Critical Path Lengths in PERT Networks," Operations Research, Vol 10, Nov 1972, pages 808-817.
5. Honeywell Report, BP49, PERT/Time Reference Manual, May 1973.
6. Klingel, "Bias in PERT Project Completion in the Calculations for a Real Network," Management Science, 13 Dec 1966, page 194.
7. Koontz, Harold and Cyril O'Donnell, Principles of Management: An Analysis of Managerial Functions, Fifth Ed., McGraw-Hill Book Company, New York, 1972.
8. MacCremmon, K. R., "An Analytical Study of the PERT Assumptions," Operations Research, Vol 12, Jan-Feb 1964, pages 16-37.
9. McMillan, Claude, and Richard F. Gonzalez, Systems Analysis: A Computer Approach to Decision Models, Third Ed., Richard D. Irwin, Inc., Homewood, IL 60430, 1973.
10. Moder, Joseph J., and Cecil R. Phillips, Project Management with CPM and PERT, Van Nostrand Reinhold Co., New York, 1970.

GLOSSARY

1. An activity is any portion of a project that consumes time or resources and has a definable beginning and end. Activities are depicted in a network as lines or arrows with descriptions and time estimates written along the line.
2. The activity duration is the most likely calendar time needed to accomplish the task with usual commitment of funds, manpower, facilities, etc. In TAC PERT the activity duration, also called a time estimate, is measured in weeks and tenths of weeks for unit conversions.
3. The actual date is the actual calendar day that an activity was started or completed. This date has a prefix "A" in the TAC PERT.
4. A bar chart is a time-phased depiction of activities. Usually the activity is identified and described on the left half of the bar chart. Then the start and finish points for the activity together with the activity duration and slack are depicted in a time-phased manner on the right half of the bar chart. This chart is sometimes called a "Gantt Chart" in respect for its inventor.
5. A block of activities is a collection of activities usually having common tasking or responsibility. These activities are depicted together on a set of bar charts.
6. A burst event is a point in a network where many activities may be started after the event has occurred.
7. A completion date is the actual calendar day that an activity was completed. This date has a prefix "C" in the TAC PERT listing or a prefix "A" in the latest finish column of a TAC PERT bar chart. This date is the earliest date for subsequent activities.
8. A construction dummy is a pseudo activity used to link two events that have a dependency relationship. A construction dummy has a "CD" in the first two positions of the activity description. Construction dummies are frequently used to eliminate PERT logic errors, enhance subnetwork displays, and provide for contingencies.
9. The critical path is that set of activities that has the minimum program slack and can be considered the longest duration path through the network. Time compression must be effected on this path to achieve an overall program time reduction.

10. The critical slack is the minimum of the activity slack values. The critical slack can be positive, zero, or negative. If the critical slack is negative, this represents the time the program completion will be late given complete accuracy of the network logic and time estimate.

11. A duplicate activity violates the PERT rule that each activity is uniquely identified by its predecessor and successor event numbers. A construction dummy is frequently used to overcome this error.

12. The earliest date is that date resulting from a forward pass computation. This is the earliest calendar date an activity may begin or end given the scheduled completion of all of its logical predecessors.

13. An event is a point in time or milestone in the project. An event is often called a "node" and is depicted as a circle or rectangle with an event number (and date) written inside. Every activity must have a predecessor event that marks the start of the activity and a successor event that marks the completion of the activity.

14. An event number is a numeric designation used to specify the network logic to the computer. For example, several activities which all start at the same point would have the same predecessor event number.

15. The expected date is the same as the earliest date. The term expected here has the connotation "earliest" not the connotation "obligatory."

16. EZ PERT is the trademark for a commercial PERT software display package. This package takes a computer file containing the TAC PERT listing and provides the plotter commands needed to produce bar charts, networks, or XY plots. This package is owned by Systonetics Inc., Anaheim, California 92801.

17. Float is another name for slack. The value of float is defined as the difference between the earliest date (start or finish) and the latest date (start or finish, respectively).

18. Job Control Language or JCL is the computer program of instructions that call the various software packages and computer programs and produces a specified output product. The JCL was prepared by TAC/ADU and requires only a "RUN" command to produce the desired product.

19. The latest date is that produced by the backward pass computation. This date is the latest calendar date the activity may begin or end and still achieve the desired program completion.
20. A line is used in a network to denote an activity neither the length of the line nor its compass direction have any significance.
21. A merge event is a point in a network where two or more activities terminate at a single event.
22. A network is a graphic depiction using event blocks and inter-connecting lines to show the interrelationships between the tasks needed to complete a project. Lines or arrows in a network imply logical precedence only.
23. A node is another name for an event. This point in time may be depicted as a circle, rectangle, or polygon in a network.
24. The OCR, or Office of Collateral Responsibility is any agency whose assigned function is involved to a secondary degree in a transaction or other matter which is the primary responsibility of another agency. In PERT, the OCR is usually an agency involved in the accomplishment of a specific activity but is not under the direct control of the Tactical Air Command.
25. The OPR, Office of Primary Responsibility, is that agency having primary functional interest in or responsibility for a specific activity. In PERT, the OPR is the agency who is either primarily interested in or actually responsible for the accomplishment of the activity.
26. Given a bar chart defined to be a specific size, paging occurs when the horizontal time line is too long to be displayed within the stated horizontal size.
27. A plan is a scheme or proposed method for accomplishing a mission or reaching an objective. Since a plan is a vision of the future, a plan changes as the vision becomes increasingly clear and is thus dynamic and not static.
28. A programming plan (P-Plan) is a TAC device for defining a program objective, providing a specific plan as to how this objective will be attained, and providing certain authorization to lower echelon agencies to accomplish the plan. The specifics of a TAC P-Plan are outlined in TACR 27-1.

29. The predecessor event number is the number used to designate the start of an activity. The earliest and latest start dates are associated with the predecessor event number.
30. PERT Start is the initial event of the network. This point scopes the network with regard to the present. The date associated with this point initializes the forward pass computation.
31. PERT Stop is the terminal point of the network and scopes the network with regard to the future. The date associated with PERT stop is the desired completion date of the program and initializes the backward pass computation.
32. Slack is the difference between the earliest (start or finish) date resulting from the forward pass computation and the latest (start or finish) date resulting from the backward pass computation.
33. Given a bar chart defined to be a specific size, sheeting occurs when the number of activities is more than can be displayed within the stated vertical size.
34. The scheduled date is a planned start date provided by the OPR. This date is displayed in a TAC PERT barchart or listing with a prefix "S". Unlike the actual start date, the scheduled date does not affect the computation of subsequent activities.
35. A subnetwork is a depiction of only a portion of the program. A subnetwork usually displays a major functional or agency related area. A subnetwork is compatible with the overall network through use of interface events (usually polygons).
36. The successor event number is the number used to designate the completion of an activity. The earliest and latest finish dates as well as the actual completion date are associated with the successor event number.
37. A work-breakdown structure is a product-oriented systematic structuring of the elements of a project. The result of a work breakdown structure should be a comprehensive program activity list.
38. The WWMCCS is the World-Wide Military Command and Control System. At Langley AFB, the WWMCCS consists of two Honeywell 6000 computers with assorted peripheral equipment. This is the computer equipment used to automate the TAC PERT.

DISTRIBUTION LIST

HQ PACAF/XPP Hickam AFB, HI 96853	4
18 TFW/CC APO San Francisco 96239	2
33 TFW/CC Eglin AFB, FL 32542	2
56 TFW/CC MacDill AFB, FL 33608	2
388 TFW/CC Hill AFB, UT 84406	2
Defense Documentation Center Cameron Station Alexandria, VA 22314	2
HQ TAC	
XPP	4
XPB	4
ACM	2
LGX	1
ADU	1
DPX	1
HO	1
AUL/LD Maxwell AFB, AL 36112	1

UNCLASSIFIED

SECURITY CLASSIFICATION OF THIS PAGE (When Data Entered)

REPORT DOCUMENTATION PAGE		READ INSTRUCTIONS BEFORE COMPLETING FORM
1. REPORT NUMBER TN 79-5	2. GOVT ACCESSION NO.	3. RECIPIENT'S CATALOG NUMBER
4. TITLE (and Subtitle) A User's Guide for TAC PERT		5. TYPE OF REPORT & PERIOD COVERED
		6. PERFORMING ORG. REPORT NUMBER
7. AUTHOR(s) Edward H. Merry		8. CONTRACT OR GRANT NUMBER(s) NA
9. PERFORMING ORGANIZATION NAME AND ADDRESS HQ Tactical Air Command Langley AFB, VA 23665		10. PROGRAM ELEMENT PROJECT, TASK AREA & WORK UNIT NUMBERS XPBSM
11. CONTROLLING OFFICE NAME AND ADDRESS TAC/XPB Langley AFB, VA 23665		12. REPORT DATE
		13. NUMBER OF PAGES
14. MONITORING AGENCY NAME & ADDRESS (if different from Controlling Office) NA		15. SECURITY CLASS. (of this report) UNCLASSIFIED
		15a. DECLASSIFICATION/DOWNGRADING SCHEDULE
16. DISTRIBUTION STATEMENT (of this Report)		
17. DISTRIBUTION STATEMENT (of the abstract entered in Block 20, if different from Report) NA		
18. SUPPLEMENTARY NOTES NA		
19. KEY WORDS (Continue on reverse side if necessary and identify by block number) Program Management Plotter Software PERT WMCCS Modernization		
20. ABSTRACT (Continue on reverse side if necessary and identify by block number) This note documents the use of the Program Evaluation and Review Technique (PERT) to assist in the close management of large programs. This note includes a general description of PERT/methodology, specific conventions used in adopting this methodology to TAC's hardware and software, a description of the output products available and a discussion of utility and requirements of this tool in program management. The results are referred to as TAC PERT.		

DD FORM 1473
1 JAN 73

EDITION OF 1 NOV 65 IS OBSOLETE

UNCLASSIFIED

SECURITY CLASSIFICATION OF THIS PAGE (When Data Entered)