

AD-A068 025

CONSTRUCTION ENGINEERING RESEARCH LAB (ARMY) CHAMPAI--ETC F/G 10/1  
PROJECT DEVELOPMENT GUIDELINES FOR CONVERTING ARMY INSTALLATION--ETC(U)  
MAR 79 S A HATHAWAY, M TSENG, J S LIN

UNCLASSIFIED

CERL-IR-E-148

NL

| OF |  
AD  
A068025



END  
DATE  
FILMED  
6-79  
DDC

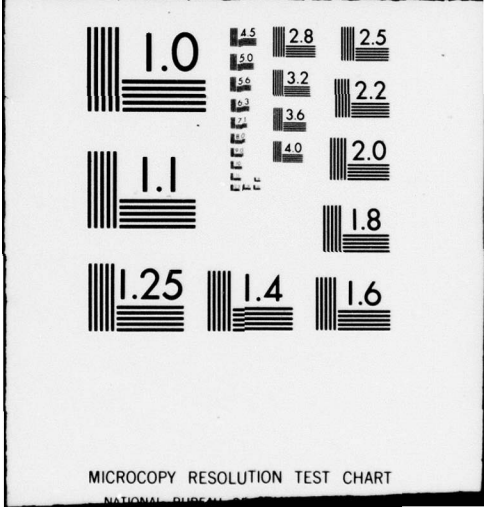

construction  
engineering  
research  
laboratory



United States Army  
Corps of Engineers  
... Serving the Army  
... Serving the Nation

12  
B.S.

INTERIM REPORT E-148  
March 1979

**LEVEL II**

PROJECT DEVELOPMENT GUIDELINES FOR CONVERTING  
ARMY INSTALLATIONS TO COAL USE

AD A 068025

DDC FILE COPY

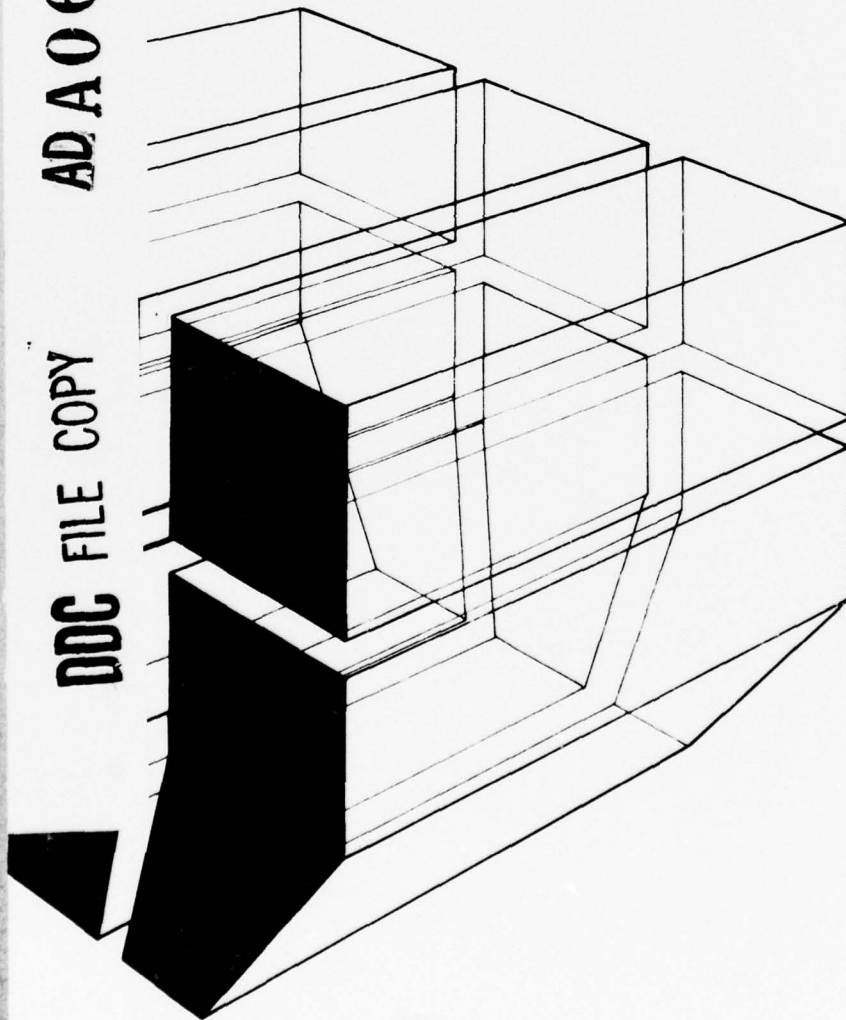

by  
S. A. Hathaway  
M. Tseng  
J.S. Lin

DDC  
RECEIVED  
MAY 1 1979  
REGULATED  
D



The contents of this report are not to be used for advertising, publication, or promotional purposes. Citation of trade names does not constitute an official indorsement or approval of the use of such commercial products. The findings of this report are not to be construed as an official Department of the Army position, unless so designated by other authorized documents.

*DESTROY THIS REPORT WHEN IT IS NO LONGER NEEDED  
DO NOT RETURN IT TO THE ORIGINATOR*

REPORT DOCUMENTATION PAGE		READ INSTRUCTIONS BEFORE COMPLETING FORM
1. REPORT NUMBER <b>14</b> CERL-IR-E-148 ✓	2. GOVT ACCESSION NO.	3. RECIPIENT'S CATALOG NUMBER
4. TITLE (and Subtitle) <b>6</b> PROJECT DEVELOPMENT GUIDELINES FOR CONVERTING ARMY INSTALLATIONS TO COAL USE	<b>9</b>	5. TYPE OF REPORT & PERIOD COVERED INTERIM <i>rept.</i>
7. AUTHOR(s) <b>10</b> S. A./Hathaway M./Tseng J. S./Lin		6. PERFORMING ORG. REPORT NUMBER
8. PERFORMING ORGANIZATION NAME AND ADDRESS U.S. ARMY CONSTRUCTION ENGINEERING RESEARCH LABORATORY P.O. Box 4005, Champaign, IL 61820	<b>16</b>	10. PROGRAM ELEMENT, PROJECT, TASK AREA & WORK UNIT NUMBERS 4A762731AT41-06-016
9. CONTROLLING OFFICE NAME AND ADDRESS	<b>11</b>	12. REPORT DATE March 1979
14. MONITORING AGENCY NAME & ADDRESS (if different from Controlling Office) <b>12</b> 41p.		13. NUMBER OF PAGES 41
16. DISTRIBUTION STATEMENT (of this Report) Approved for public release; distribution unlimited.		15. SECURITY CLASS. (of this report) Unclassified
17. DISTRIBUTION STATEMENT (of the abstract entered in Block 20, if different from Report)		15a. DECLASSIFICATION/DOWNGRADING SCHEDULE
18. SUPPLEMENTARY NOTES Copies are obtainable from National Technical Information Service Springfield, VA 22151		
19. KEY WORDS (Continue on reverse side if necessary and identify by block number) Army installations power systems fuel		
20. ABSTRACT (Continue on reverse side if necessary and identify by block number) This report provides technical and economic information to help Army Facilities and District Engineers develop projects for converting installation heating and power systems to using coal as a primary fuel. The report includes a general overview of the coal conversion and supply problem; coal delivery, handling, and storage; boiler conversion; boiler replacement; salvage fuels; coal gasification; and air pollution control.		

405 279 *Dec*

## FOREWORD

This study was performed by the U.S. Army Construction Engineering Research Laboratory (CERL) for the Directorate of Military Programs, Office of the Chief of Engineers, under Project 4A762731AT41, "Design, Construction, and Operation and Maintenance Technology for Military Facilities," Task Area 6, "Energy Systems," Work Unit 16, "Coal Utilization." Mr. L. Keller (DAEN-MPO-U) served as the OCE Technical Monitor. The CERL Principal Investigator was Mr. S. Hathaway of the Energy and Habitability Division (CERL-EH).

Appreciation is extended to the following personnel for ideas incorporated into various technical portions of this investigation: Mr. B. Donahue, Sanitary Engineer, CERL Environmental Division (CERL-EN); Mr. J. Donnelley, Mechanical Engineer, DAEN-MPO-U; Mr. D. Ekstrom, Mechanical Engineer, USA DARCOM, Rock Island, IL; Dr. E. Honig, Metallurgist, USA TARADCOM, Detroit, MI; Mr. L. Wesolowski, Geologist, CERL-EN; Mr. R. Ridgway, Chief Engineer, Joliet Army Ammunition Plant, Joliet, IL; Mr. G. Schanche, Sanitary Engineer, CERL-EN; Mr. S. Struss, Environmental Engineer, CERL-EN; Mr. B. Wasserman, Mechanical Engineer, DAEN-MPO-U; Mr. D. Williams, Mechanical Engineer, Naval Civil Engineering Laboratory, Port Hueneme, CA; and Mr. R.D. Winn, Mechanical Engineer, DAEN-MPO-U. Administrative support was provided by Mr. R. G. Donaghy, Chief, CERL-EH.

COL J. E. Hays is Commander and Director of CERL, and Dr. L. R. Shaffer is Technical Director.

<b>ACCESSION for</b>	
DTIC	White Section <input checked="" type="checkbox"/>
DDO	Buff Section <input type="checkbox"/>
UNANNOUNCED	<input type="checkbox"/>
JUSTIFICATION	
BY	
DISTRIBUTION/AVAILABILITY CODES	
Dist. AVAIL. and/or SPECIAL	
A	

D D C  
RECEIVED  
MAY 1 1979  
D

79 04 27 013

## CONTENTS

DD FORM 1473	1
FOREWORD	3
LIST OF TABLES AND FIGURES	6
<b>1 INTRODUCTION</b> .....	<b>7</b>
Background	
Objective	
Approach	
Scope	
Mode of Technology Transfer	
<b>2 MAJOR FINDINGS ON</b>	
<b>COAL CONVERSION AND SUPPLY</b> .....	<b>8</b>
Installation-Level Parameters of Coal Conversion	
Coal Supply	
Information Required for Project Development	
<b>3 DELIVERY, HANDLING, AND STORAGE</b> .....	<b>10</b>
Unloading	
Preparation	
Transfer	
Outdoor Storage	
Covered Storage	
In-plant Handling	
Weighing and Measuring	
<b>4 COMBUSTION SYSTEMS I: BOILER CONVERSION</b> .....	<b>14</b>
Coal-Convertible Boilers	
Determining Convertibility	
Fuel Considerations	
Case I: Gas and Oil to Coal (Utility)	
Case II: Gas and Oil to Coal (Industrial)	
Case III: Gas and Oil to Coal (Industrial)	
Case IV: Gas and Oil to Coal (Industrial)	
Case V: Restoration of Coal Capability (Industrial)	
Case VI: Coal-Convertible, Oil-Fired Boiler to RDF (Industrial)	
Case VII: Firing Coal and POL (Industrial)	
<b>5 COMBUSTION SYSTEMS II: BOILER REPLACEMENT</b> .....	<b>17</b>
Stokers	
Ash and Residue Removal	
Controls	
Costs	
<b>6 SALVAGE FUELS</b> .....	<b>22</b>
RDF	
POL	
Wood Waste (Biomass)	

7	COAL GASIFICATION .....	23
	Furnace Considerations	
	Gasification System and Costs	
8	AIR POLLUTION CONTROL .....	24
	Particulate Control	
	Flue Gas Desulfurization	

REFERENCES  
DISTRIBUTION

## TABLES

Number	Page
1 General Information for Project Development	10
2 General Stoker Characteristics	19
3 Influence of Fuel Properties on Firing Method	19
4 Composition of Coal-Derived Gas from Koppers-Totzek Process	26
5 Cost Items: Limestone Slurry Process	32
6 Cost Items: Lime Slurry Process	33
7 Cost Items: Magnesia Slurry-Regeneration Process	35
8 Cost Items: Sodium Solution - SO <sub>2</sub> Reduction Process	35
9 Cost Items: Catalytic Oxidation Process	37

## FIGURES

Number	Page
1 Furnace Size Vs. Fuel Fired	15
2 Influence of Coal Type on Furnace Size	16
3 Spreader Stoker With Traveling Grate	20
4 Chain Grate Stoker	21
5 Koppers-Totzek Coal Gasification Process	25
6 Koppers-Totzek Coal Gasifier	26
7 Typical Cyclone Configurations	28
8 Schematic of Surface Type ESP	29
9 Typical Baghouse Construction	31
10 Limestone Slurry Process	32
11 Lime Slurry Process	32
12 Magnesia Slurry-Regeneration Process	33
13 Sodium Solution - SO <sub>2</sub> Reduction Process	34
14 Catalytic Oxidation Process	36

# PROJECT DEVELOPMENT GUIDELINES FOR CONVERTING ARMY INSTALLA- TIONS TO COAL USE

## 1 INTRODUCTION

### Background

One objective of the national energy strategy set forth by the President on 29 April 1977 is to reduce dependence on foreign oil and thereby limit vulnerability to supply disruptions.<sup>1</sup> In response, the Army Advisory Group on Energy adopted Army-wide goals of reducing both energy consumption and dependence on nonrenewable and scarce fuels. A major objective of the Army Energy Plan is to eliminate use of natural gas and reduce the use of petroleum by 75 percent by the year 2000. In meeting this challenge, it is expected that many installation heating and power plants now firing gas or oil will be converted to coal.

Recognizing the need to use coal as a primary fuel wherever possible,<sup>2</sup> the Directorate of Facilities Engineering, Office of the Chief of Engineers (OCE), initiated a requirement for technical and economic guidance for use by Facilities and District Engineers in the planning, design, and operation of modern coal systems in Army fixed facilities and installations.

This work is being conducted in several phases. The first phase, completed in FY77, comprised a review of current and advanced coal technologies to determine which have potential near-term Army application, and recommended that installation coal conversion efforts emphasize proven direct combustion technologies.<sup>3</sup> The second phase of work is to provide general technical and economic guidance on applicable coal technologies for use by District and Facilities Engineers in developing installation coal use projects. This is the subject of the study reported here.

<sup>1</sup>Army Energy Plan (Headquarters, Department of the Army [DA], 1978).

<sup>2</sup>*Heating, Energy Selection and Fuel Storage, Distribution, and Dispensing Systems*, AR 420-49 (DA, 1976).

<sup>3</sup>Honig, E. M., Jr., and S. A. Hathaway, *Application of Modern Coal Technologies to Military Facilities*, Interim Report E-130/AD055560 (U.S. Army Construction Engineering Research Laboratory [CERL], 1978).

### Objective

The objective of this report is to provide Facilities and District Engineers with general technical and economic guidance for developing coal conversion projects on Army fixed facilities and installations.

### Approach

This study was accomplished in the following steps.

1. A literature review was conducted to obtain investment cost and operations and maintenance (O&M) data on (a) coal use technologies identified as having potential installation application; (b) salvage fuels such as refuse-derived fuel (RDF),<sup>4</sup> petroleum oils and lubricants (POL), and waste wood which have potential for cofiring with coal; and (c) systems for removing particulate and gaseous sulfur and nitrogen oxide pollutants from stack gases.

2. A field analysis was carried out to supplement information gathered in the literature review. This analysis of operating systems emphasized both salvage fuel systems and flue gas desulfurization technologies. The latter portion was conducted in cooperation with the CERL Environmental Division, which is investigating state-of-art flue gas desulfurization systems for potential Army use.<sup>5</sup>

3. Technical and economic data on applicable coal use, salvage fuel, and flue gas treatment technologies were reduced and manipulated for presentation in a format suitable for field use in project development.<sup>6</sup> All cost data were adjusted to FY78 values by using construction cost indices published in Army Regulation 415-17.<sup>7</sup> Published data for large plants were downscaled to represent the typical range of Army boiler capacities (25 to 200 MBtuh [7.2 to 58 MW]) using established scaling factors.<sup>8</sup>

<sup>4</sup>Hathaway, S. A., *Technology Evaluation of Army-Scale Waste-to-Energy Systems*, Interim Report E-100/ADA042578 (CERL, 1977).

<sup>5</sup>*A Systematic Study of Viable Strategies for the Control of Sulfur Oxide Emissions from Army-Size Boilers* (U.S. Army Armament Readiness Command, Appropriation 2182040-08-1704, 1978).

<sup>6</sup>Personal Communication with Mr. L. Keller, Directorate of Facilities Engineering, Office of the Chief of Engineers, Washington, DC, 12 October 1977.

<sup>7</sup>*Empirical Cost Estimates for Military Construction and Cost Adjustment Factors*, AR 415-17 (DA, 1977).

<sup>8</sup>*Energy Production by Solid Waste Incineration*, Report FESA-RT-2036 (U.S. Army Facilities Engineering Support Agency, 1977).

4. The final stage of the study involved arranging and reporting technical and economic data in a format suitable for field use as an engineering technical note, bulletin, or letter.<sup>9</sup> Chapters 2 through 8 of this report may be used for this purpose.

#### Scope

This report contains general techno-economic information for converting installation heating and power plants ranging in capacity from 25 to 200 MBtuh (7.2 to 58 MW) to coal as a primary fuel. The report covers (1) a general overview of the installation coal conversion and supply problem; (2) delivery, storage, and handling of coal; (3) conventional stoker-firing technology; (4) coal gasification; (5) salvage fuels; and (6) systems for reducing emission of particulate material and gaseous sulfur and nitrogen oxides.

#### Mode of Technology Transfer

OCE will issue information in this report as an Engineer Technical Letter for use by Facilities and District Engineers in developing coal conversion projects for Army fixed facilities and installations.

## 2 MAJOR FINDINGS ON COAL CONVERSION AND SUPPLY

The Army-wide goal of reducing natural gas and oil consumption by converting to coal as a primary fuel in installation heating and power plants requires resolution of numerous key technical factors at installation level. These factors include the design of the existing heating and power plant system and whether facilities and land area exist for the delivery, handling, and storage of coal. The following paragraphs summarize findings of that portion of the study which investigated installation-level potential for coal conversion and supply.

#### Installation-Level Parameters of Coal Conversion

This study found that the problem of installation coal conversion is considerably more complex than Army-wide goals indicate. Essential findings with respect to the overall coal conversion problem are as follows.

<sup>9</sup>Personal Communication with Mr. K. D. Winn, Directorate of Facilities Engineering, OCE, Washington, DC, 23 June 1978.

1. Systems for producing and distributing energy appear to be unique to the individual installation and therefore are difficult to categorize generically. Some installations (notably ammunition plants) have an elementary two-plant, one-loop system, some have more than one plant with each serving a different user sector, and others may have a small central plant with as many as two dozen smaller outlying plants, each serving a different sector. Still others have no major central plant, but have numerous small outlying plants, each serving an isolated cluster of users. In nearly all cases, small outlying plants consist of up to four package gas- or oil-fired boilers. Economy of scale precludes replacing small outlying clean fuel-fired plants with coal-fired boilers. Where there is a significant number of outlying plants, it may be cost-effective to produce and distribute to them a gaseous coal-derived fuel. Conversely, it may be cost-effective to build a large central system to distribute energy to outlying users. In this case, retirement of outlying plants could be at a financial loss to the Army, since their terminal value is expected to be low because of a projected market decline for package boilers firing scarce fuels.

2. Most Army boilers produce saturated steam in the pressure range from 100 to 180 psig (690 000 to 1 240 000 Pa) for heating and cooling. Few produce electrical power, and, of those, most produce electrical power for in-plant use. Some plants produce superheated steam. Load profiles can vary widely among installations.

3. Many installations never used coal and hence do not have receiving, handling, and storage facilities. Many installations that switched from coal to cleaner fuels have put original coal storage areas to other use. At some of these installations, the physical plant has been built up near the central heating and power plants, reducing the area available for coal storage, ash disposal, and gas cleanup equipment. Most Army heating and power plants also lack space within the plant itself for bunkers, gas cleanup equipment, and other hardware necessary for coal use. Original equipment at many plants that switched from coal is either technologically obsolete, in poor repair, partially cannibalized, or completely gone.

4. The original design basis of older Army boilers is often unknown, inhibiting assessment of their capability to fire a particular coal at rated capacity. While some oil-fired boilers were designed to be coal-convertible, the basis of this design is highly variable and often indeterminable.

5. Some Army boilers with coal-firing capability were designed to fire a wide range of coals. These have the highest probability of successful coal conversion. Army boilers with tight design fuel limitations face up to 60 percent derating, depending on the coal available.

6. Design information on Army boilers is extremely difficult to obtain, inhibiting both assessment of Army-wide coal conversion potential and formulation of a rational coal-conversion program.

7. Lag times of industrial-scale coal conversion are now as much as 3 years after equipment order and are expected to lengthen. Manufacturers and architect/engineers (A/E's) often do not possess the necessary manpower to handle the projected large work volume in addition to their regular workload. Because of this, it is probable that a long-term, rationally planned phasing-in program coordinated with the other services, industry, and other government agencies will bring better results than an uncoordinated, competitive, hit-and-miss approach.

8. Use of salvage fuels (solid waste, biomass, POL) either by heat-recovery incineration or as a coal-supplement is a bright prospect both for conserving coal consumption and possibly for diluting sulfur oxide emissions in flue gas either to within compliance concentrations or to concentrations that are more easily and economically treated. The Army currently has seven waste-to-energy projects and a broad RDT&E program, and should continue its leadership role in this area.

#### **Coal Supply**

The problem of coal supply to installations is similar to that faced by most industrial coal consumers. Essential findings with respect to the overall coal supply problem are as follows.

1. Army boiler plants designed for a particular coal may find design basis coal unavailable for reconversion because of the relatively long time since design and the competition for supply.

2. It is probable that coal conversion will require addition of flue gas desulfurization equipment. While present emission standards are 1.2 lb SO<sub>2</sub>/MBtu (2790 kg/J) fired, the U.S. Environmental Protection Agency (USEPA) has proposed new legislation requiring 90 percent SO<sub>2</sub> removed regardless of the sulfur in the coal. Moreover, the Clean Air Act Amendments of 1977 (PL 95-95) encourage use of a scrubber on all applications regardless of sulfur level. Competition for

low-sulfur coals is growing, but may change in response to both these proposals. Finally, pressures to inhibit importation of "better" coals into states with large demonstrated reserves of "poorer" coals are expected. Coal procured by installations will probably be non-compliant in terms of sulfur content.

3. The magnitude of individual installation coal consumption and, often, the nature of the procurement agreement will affect coal use. In terms of equivalent tons of coal per year, installations are small energy consumers in a nationwide context and individually will not contribute as much as a utility will to a supplier's profit. It has not been unusual for coal-burning installations to receive off-specification coal from suppliers who can sell it nowhere else. New and retrofit coal-fired boilers should be designed to burn as wide a range of coal as possible to ensure optimal energy production in face of the unpredictable quality of delivered coal.

#### **Information Required for Project Development**

Development of a coal conversion project requires a well thought out concept of what the project entails. Later chapters of this report provide conceptual technical information and general cost data to support the project development effort. The following minimal information base is required (Table 1).

1. The project developer must know the type of boilers and their respective design basis currently at the installation. While it is not difficult to convert coal-designed boilers to gas or oil, conversion of boilers designed for gas or oil to coal at nominal rating is seldom cost-effective because boiler rebuilding and auxiliary equipment additions are required. Most manufacturers and A/Es now prefer replacing gas- and oil-designed boilers with coal-fired units rather than converting units. The project developer should also obtain records indicating historical steam production trends for each boiler in order to determine required operating hours per year and required turndown.

2. The project developer must also obtain information on the coal that will probably be used, since nature of the fuel to be burned is the key factor in coal conversion programs, bearing directly on selection and cost of storage, handling, combustion, and pollution control systems. Probable supply coals can be identified with the assistance of the Defense Fuel Supply Agency and by referring to standard industry sources such as the Keystone annual *Coal Industry Manual*.<sup>10</sup>

<sup>10</sup>Keystone Coal Industry Manual (McGraw-Hill, 1976).

**Table 1**  
**General Information for Project Development**

Probable Coal Supply	Installation Steam Needs
Cost (\$/ton and \$/MBtu)	Distribution system
Proximate Analysis	Historical steam trends (yearly, monthly, daily, hourly)
Ultimate analysis	Seasonal loads
Calorific value	Load variations
Ash analysis	Projected steam trends
Density	Availability of Salvage Fuels
Flow properties	RDF
	Biomass
	POL
Installation Boiler Plants	
Nameplate data	
Design fuel	
Steam quantity and quality	
Original design package	
On-hand coal equipment	
Available area for coal equipment	

3. The project developer must have information regarding availability of salvage fuels (RDF, biomass, POL) which could be burned with coal. Caution must be exercised here. While RDF has been widely publicized, there are no long term data regarding its performance as a coal supplement in converted boilers. However, use of RDF, biomass, and POL in new boilers specifically designed for them alone or in combination with coal is state-of-art technology.

It has been shown that many installations do not generate enough solid waste to make RDF production cost-effective. The best prospects for installation use of RDF lie in purchase of the waste fuel from large regional waste-processing facilities. It is possible that by the time a coal conversion project goes into design, current questions pertaining to procurement agreement will be resolved.

### **3 DELIVERY, HANDLING AND STORAGE**

Systems for delivering, handling, and storing coal are largely independent of the particular coal use technology selected, but not of the nature of the coal procured. Calorific values range from 12,000 Btu/lb (27.9 MJ/kg) for Eastern bituminous coal to 6800 Btu/lb (15.8 MJ/kg) for Northern Plains lignite. (Some U.S. coals have a calorific value as low as 3900 Btu/lb [9.1 MJ/kg]). Moisture content can range from 6 per-

cent (Eastern bituminous) to 37 percent (Northern plains lignite). For equal boiler plant heat input, about 16 times more lignite than Eastern bituminous coal must be stored, handled, and fired. This chapter provides general information on the major unit operations, equipment, and costs of coal delivery, handling, and storage systems.

The major unit operations for delivery, handling, and storage of coal are: unloading, preparation, transfer, outdoor storage, covered storage, in-plant handling, and weighing and measuring. Not all these operations need be involved in an installation coal use system, nor must they occur in the stated sequence. For example, coal delivered by rail or boat might go through unloading, preparation, transfer, and outdoor storage before entering covered storage. But coal delivered by truck might go directly to covered storage.

#### **Unloading**

Selection of a coal unloading system depends on how the coal is delivered. Equipment to accommodate rail or boat delivery includes car and barge movers, car thawing equipment, car shakers, rotary car dumpers, cranes and buckets, unloading towers, portable conveyors, lift trucks with scoops, track hoppers and various types of feeders. Truck delivery is by far the easiest mode to manage and usually does not require equipment specifically intended for unloading. Coal delivered by truck can be sent directly to outdoor storage or to a conveyor for delivery to in-plant bunkers. Capital cost of rail and boat unloading facilities for

larger installation-scale operations can range up to \$3,000,000. Labor, repair and maintenance, and electrical power are important recurring costs.

Coal should be unloaded as rapidly as possible to minimize labor cost and, for boat and rail systems, to avoid demurrage charges. Industry trends are to provide sufficient capability to unload a 3-day coal supply in a single 8-hour shift. This corresponds to an unloading rate about nine times the maximum total plant coal burning rate.

When rail systems are used, coal is customarily received in hopper-bottom cars ranging in capacity between 50 and 100 tons (1400 to 2800 Mg). Delivery time should be planned liberally because cars require time for spotting, moving on the siding, and sometimes shaking and thawing. Because of this, the design coal handling rate of the conveyor system is about twice the design unloading rate. If larger-than-normal shipments arrive, the conveyor system can be operated more than 1 shift/day to reduce demurrage charges.

#### **Preparation**

Coal preparation operations at installation-scale coal-fired heating and power plants are usually limited to crushing, and, since stoker coal is normally procured in the necessary size, this operation is often not necessary. Crushing ensures that optimally sized coal goes to the boiler; accordingly, crushers are used when there is economic advantage in buying large lump or run-of-mine coal. In this case, coal is screened before it enters the crusher to minimize production of fines.

Several types of coal crushers are available: rotary breakers, single-roll crushers, double-roll crushers and hammermills. Selection of the proper configuration and size depends on: type of coal, condition of coal (wet, dry, or frozen), Hardgrove grindability, type of crusher feeder, feed size to crusher, product size, allowable fraction of fines, and throughput capacity. Breakers and hammermills yield lumps of a given maximum size, because all coal passes through screen openings before discharge. Roll crushers may occasionally pass oversize lumps. Manufacturers normally guarantee that only 80 to 90 percent of the crushed coal product will pass a specified screen size.

Coal is usually crushed before covered storage. Facilities using outdoor storage usually crush coal after it is reclaimed from the pile, but before it is placed in a protected area.

The capital cost for coal crushing systems ranges between \$80,000 and \$700,000. Important recurring costs are for maintenance and repair and electrical power.

#### **Transfer**

Transfer refers to handling between the unloading point and final storage, from which coal discharges to firing or processing operations. Typically used transfer equipment includes skip hoists, bucket elevators, and belt conveyors.

Transfer operations should be as simple as possible. In the case of a plant where trucks dump coal in a yard storage pile, a lift truck with a scoop can take it directly to the closed storage feed system. Often, however, a conveying system is needed because there are reserve and active coal inventories to be manipulated. A typical installation transfer system could include an elevating belt conveyor from the unloading point (i.e., delivery hopper under rail head) to enclosed storage. Most belt conveyors are equipped with a magnetic head pulley to remove tramp iron. A transfer chute can be installed midway through the conveyor flight to divert the coal to open storage.

Elevating belt conveyors have maximum inclines of about 20 degrees, and hence require substantial length of travel if in-plant storage is high. An alternative is the bucket elevator system. With this system, coal can be unloaded from rail car or truck to a delivery hopper adjacent to the plant and lifted directly up to in-plant storage.

Capital costs of transfer systems vary widely. Trucks average about \$18,000 and scoops about \$20,000. Elevating conveyor systems can be as high as \$350,000, and bucket elevator systems as much as \$400,000. Important recurring costs are electrical power for the conveying systems and fuel, labor, and O&M for the vehicular systems.

#### **Outdoor Storage**

Coal storage can be divided into two categories: active and reserve. Active storage supplies coal-firing equipment directly and is usually in-plant. Reserve storage is normally outdoors. Where outdoor storage serves only as a reserve, normal practice is to transfer part of an incoming shipment to active storage and the remainder to reserve, from which coal is reclaimed as needed.

The Department of Defense (DOD) requires that plants maintain at least a 30-day coal supply during the three coldest months of the year. Land area required for outdoor storage can be computed from Eq 1:

$$A = \frac{(w)(24)(LF)(N)}{(Ev)(d)(ht)} \quad [\text{Eq 1}]$$

where A = required storage area (sq ft)  
 W = total plant steam output capacity (lb/hr)  
 LF = winter load factor (dimensionless)  
 N = number of days storage capacity (days)  
 d = coal density (lb/cu ft)  
 ht = average pile height (ft)  
 Ev = product-to-fuel ratio (lb steam/lb coal)

The factor Ev can be calculated from Eq 2:

$$Ev = \frac{(Hv)(Eff)}{He} \quad [\text{Eq 2}]$$

where Hv = higher heating value of the coal (Btu/lb)  
 Eff = boiler plant efficiency (dimensionless)  
 He = steam enthalpy (Btu/lb)

For example, consider a boiler plant with the following operating parameters:

W = 120,000 lb steam/hr  
 LF = 0.6 (cold season load factor)  
 N = 90 days storage  
 d = 45 lb/cu ft coal density  
 ht = 15 ft average pile height  
 Hv = 12,000 Btu/lb coal heating value  
 Eff = 0.76  
 He = 1008 Btu/lb steam enthalpy

Then

$$Ev = \frac{(12,000)(0.76)}{1008} = 9.05 \text{ lb steam/lb coal}$$

and

$$A = \frac{(120,000)(24)(0.6)(90)}{(9.05)(45)(15)} =$$

25,459 sq ft (2565.2 m<sup>2</sup>) storage area

Note that the storage area required for Northern Plains lignite having a calorific value of 6800 Btu/lb (15 MJ/kg) and a density of 40 lb/cu ft (640 kg/m<sup>3</sup>) would be 55,622 sq ft (5167.5 m<sup>2</sup>) or more than twice the area required for the Eastern bituminous coal in the computed example. This illustrates why it is vital that project developers do preliminary groundwork to identify probable coal supply.

Storage area can be reduced by building the coal pile vertically. About 20 ft (6.1 m) in height is the limit for a manageable free pile. Silos and stave bins can be employed where land area is not available, but they are costly.

Coal should be stored at a site located on solid ground, well drained, free of standing water, and preferably on high ground not subject to flooding. Permanent areas are top-dressed or hard-surfaced, never on underfill or other loose or porous surface. The storage area should be cleared of all foreign matter having a low ignition temperature (i.e., wood, paper, rags, waste oil). Storage near heat sources (i.e., steam or hot water lines, furnaces, stacks, hot water tanks, hot sewer lines) should be avoided. Coal should always be spread in horizontal layers, not in conical piles. Runoff can be controlled by berms.

Equipment used in open coal storage systems includes bulldozers, scrapers, carryalls, bridges, tramways, cranes and buckets, and conveyor systems. Bulldozers and scrapers cost between \$25,000 and \$60,000. Important recurring costs are fuel, repair and maintenance, and labor. Storage systems can cost as much as \$2,000,000 for large installation-scale plants.

#### Covered Storage

Active coal storage is nearly always maintained in a covered structure such as a bin, silo, or bunker. The type of structure selected depends on the amount of coal to be stored. Bins are generally suitable for small plants, while larger plants require silos or bunkers designed to conserve floor space and permit convenient fuel flow to the process. Utility-scale plants typically use large silos or bins outside the plant.

Covered storage for reserve coal is an increasing practice. Advantages include the ability to fill and discharge without mobile equipment, minimize coal losses, and maintain coal in good condition. It is also

aesthetically preferable and maximizes use of available land area. The strongest disadvantage is its initial and operating costs.

Bunkers are overhead storage bins arranged for gravity coal flow to the coal-processing equipment. They are top fed, usually from the unloading point, by a distributing conveyor or automatic trip station when a bucket elevator is used. Bunkers are typically fabricated from steel plate and lined with concrete or gunnite.

A variety of bunker configurations exists. Cylindrical bunkers are vertical circular bins suitable for small coal operations. They are comparatively low in first cost, are self-cleaning, and lend themselves to a unitized boiler-bunker arrangement. Rectangular bunkers with multiple bottom hoppers are suitable for feeding a battery of boilers. Hopper sides are often lined with stainless steel to improve coal flow characteristics. Suspension (or catenary) bunkers also have multiple outlets suitable for feeding a battery of boilers, but are not self-cleaning.

Several Army boiler plants already have coal bunkers. Care must be taken to ensure that they will accommodate the coal to be fired, since they were probably designed for another coal with different flow properties. Careful analysis must also be made when considering using an existing bunker for RDF or RDF/coal mixtures; these solids have highly difficult flow properties and the bunker and feeding systems will normally require modification to handle them.

Bunkers are subject to large internal static loads. In retrofitting a bunker to an existing plant, careful attention must be given to the design of structural reinforcing, supporting structures, and foundations.

Installation-scale coal bunkers can cost up to \$1,000,000 depending on capacity, configuration, and installation requirements. They require very small O&M costs. A variety of flow aids such as bin vibrators and gas injection systems are available to reduce modifications required when storing a nondesign coal; their costs range between \$10,000 and \$200,000.

#### **In-Plant Handling**

In-plant handling refers to the movement of coal between final storage and processing equipment (boilers or gasification vessels). In rudimentary systems, the in-plant handling equipment can consist only of chutes to direct flow to individual processing units and valves

or gates to control flow. Some plants may include a conveying system to feed coal from any bunker outlet to any processing unit. Large-scale plants can have very complex handling systems including some or all of the following equipment: belt conveyors, scrow conveyors, flight conveyors, bucket elevators, chutes, lift trucks, monorails and tramways.

Depending primarily upon complexity and capacity, in-plant handling systems can range up to \$2,500,000 in first cost. Important recurring costs are electrical power and maintenance and repair.

#### **Weighing and Measuring**

Coal must be weighed upon delivery to ensure correct payment. It must also be weighed just before reaching the boiler (or other process vessel) in order to evaluate overall plant performance.

Delivered coal can be weighed at the unloading point or elsewhere in the handling system. Basic scale types are truck, rail, combination truck and rail, and conveyor belt units. All but the conveyor belt units record directly measured weight. The conveyor belt unit continuously weighs coal by multiplying the varying load on the belt by the belt speed. Weight indicators include dial (with optional automatic printout), registering beams, and digital indicators. Capital costs for truck scales range between \$30,000 and \$80,000, for rail scales between \$75,000 and \$160,000, and for conveyor belt weighing systems between \$20,000 and \$80,000. Cost of combination truck and rail scales can be as high as \$200,000. All costs are highly dependent on capacity, measurement mode, installation requirements, and type of readout. Important recurring cost items are maintenance and repair and electrical power.

Scales or feeders can be used to weigh coal between the bunker and process vessel. Scales have typical capacities between 10 tons/hr and 30 tons/hr and consist of a weigh-lever system, weigh hopper, and feeder. Capital costs range between \$30,000 and \$50,000, depending on capacity, type of recording device, and installation. Weigh feeders are usually limited to pulverized coal-firing and coal gasification systems. The recommended configuration is the table feeder, which operates on a start-stop basis and is controlled by the fuel demand of the vessel. Other feeders such as pocket, drag, and apron types are volumetric devices operated by the combustion control system. Belt feeders are highly accurate volumetric devices which are recommended when precise control

of particulate in flue gases is necessary, either before release to the atmosphere or entry to air pollution control equipment. Feeders with weighing capability have a cost range similar to that of scales. Important recurring costs for scales and feeders are maintenance and repair and electrical power.

## **4 COMBUSTION SYSTEMS I: BOILER CONVERSION**

Conversion of installation boilers to coal will most likely involve stoker-firing technology. Nearly all installations lack the economy of scale required to make pulverized coal systems cost-competitive with conventional stoker systems. It is probable that most, if not all, Army boilers designed to fire oil and gas will not be converted to coal, but instead will either be replaced (perhaps by larger central coal-fired units) or, in a few cases, fired with coal-derived gas. Installation boilers designed to fire gas and oil can seldom be converted to coal economically, which is a key factor in the coal conversion problem. This chapter furnishes general information on the conversion of boilers to coal.

### **Coal-Convertible Boilers**

The project developer must determine whether a given boiler can be converted to coal and maintain rating. In general, package oil- and gas-fired boilers are not convertible, while site-erected boilers designed to fire heavy fuel oil (Bunker C, heavy distillate, No. 6) may be. Of the latter, some may sacrifice rating by up to 40 percent in the conversion. Others, which were designed for coal conversion, may have only a small rating loss, depending on the nature and properties of the coal to be burned. Boilers which once fired coal can be restored to using that fuel, but, once again, the success of maintaining rated capacity depends on the supplied coal.

### **Determining Convertibility**

The most reliable way to determine the feasibility of converting a candidate boiler to coal is to ask its manufacturer. The project developer should first collect information on (1) coals most likely to be burned; (2) records indicating annual, monthly, daily and hourly steam production; (3) the original boiler plant project development package which indicates the design basis of the candidate system; and (4) boiler nameplate data. The manufacturer will probably re-

quire its own engineers to spend a day or two at the installation inspecting the candidate plant and gathering further data. The manufacturer will generally give a frank assessment of whether the boiler can be converted, and of the magnitude of work and costs involved.

It is generally imprudent for installation engineering staff to attempt such an assessment in the project development stage. Even traditional coal-use technology can be very complex, and appraisals made by design experts are more likely to be accurate.

Although it is recommended that boiler convertibility be determined by the manufacturer, the project developer can contribute to overall project success by being familiar with the technology and main problems involved. Key areas are furnaces and stokers, combustion control and management, and removal of ash and residue. A general introduction to coal combustion and boilers can be found in TM 5-650, *Repairs and Utilities: Central Boiler Plants* (DA, 1962). Chapter 5 of this report provides more detailed information on the key areas mentioned above. Subsequent paragraphs here provide general information on several cases of industrial-scale coal conversion in order to illustrate the practical and economic significance of the retrofit problem.

### **Fuel Considerations**

As stated earlier, the most important design consideration for a boiler plant is the fuel to be burned. A general idea of probable coal supply must be obtained in project development stages if a conversion project is to be technically successful.

The most important differences between coal-fired and oil- or gas-fired boilers are a direct result of the solid form of coal before burning and the ash contained in its combustion products. The combustion products from oil burning contain little ash, and natural gas produces no ash. As shown in Chapter 3, coal must be unloaded, handled, stored, and sometimes prepared before firing, whereas oil and gas require little preparation.

Coal-fired boilers must have larger furnaces because of the burnout time needed for solid coal particles and because of the ash produced. Figure 1 illustrates the different furnace sizes for coal, oil, and gas for equal steam production. The coal-fired boiler requires about 2.5 times more furnace volume than the gas-fired unit.

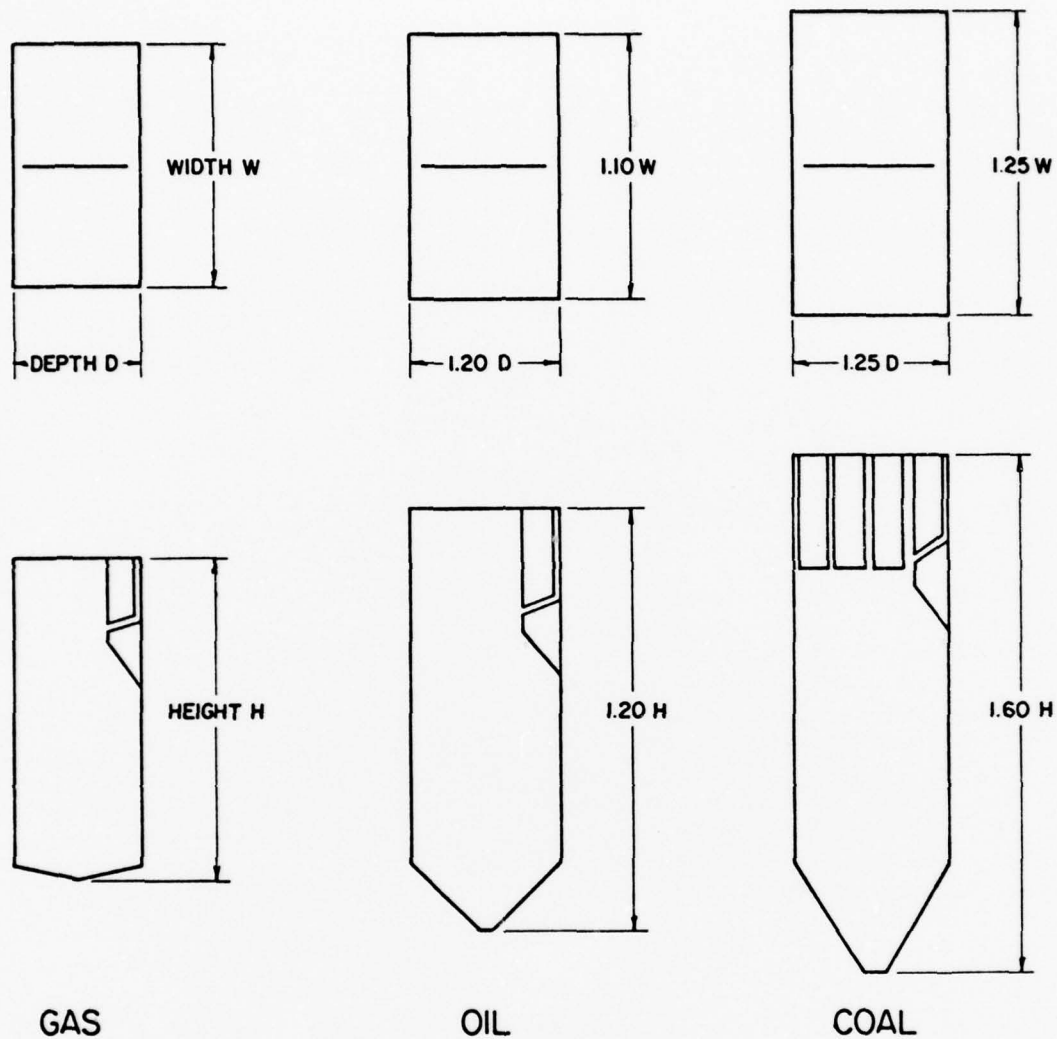

Figure 1. Furnace size vs. fuel fired.

Attempts to fire coal in the gas-designed unit would obviously result in drastically reduced steam output. Firing coal in the oil-designed unit would also result in derating.

Coal properties also play a major role in the feasibility of conversion. Differences in heating value and their impact on required outdoor storage area requirements were shown earlier. Of interest here is the interplay between ash fusion properties, the ratio of basic to acidic ash constituents, the iron/calcium ratio, ash friability, and the absolute amount of ash per MBtu fuel fired.

The furnace sizes shown in Figure 2 arise from the interplay of different coal properties. The furnaces on the right are for low-rank lignites which are high in moisture and ash and low in heating value. The furnaces on the left are for Eastern bituminous coal and high-grade Texas lignite. This figure clearly illustrates the fuel-specific design basis of coal-fired boilers. It would be possible to fire Eastern bituminous coal in the unit designed for Northern Plains lignite with little modification and probably maintain rated capacity, but the opposite is not true. Hence, even reconverting a coal-designed boiler may involve derating or else entail substantial rebuilding.

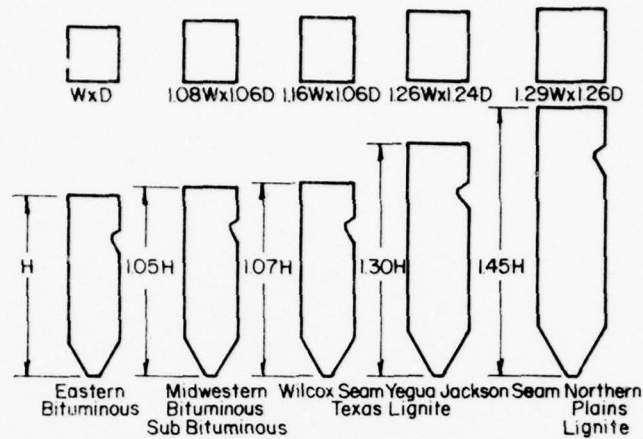

Figure 2. Influence of coal type on furnace size.

Further, suppose the oil-fired unit in Figure 1 could be fired with Eastern bituminous coal with a 20 percent derating, that this were satisfactory in light of projected steam demands at the location, and that a project were developed on this basis. A later detailed analysis revealed that only a lignitic coal could be made available, and its use would require several million dollars more in capital modifications. The original project would probably be shelved and another developed based on known coal supply, delaying the coal conversion effort up to several years.

Ash properties also vary widely among coals and are important to consider when evaluating boiler conversion, with emphasis on those properties which cause fouling and erosion in convective passes. Substantial redesign and modification is often required to ensure proper life-cycle performance of reheaters, economizers, superheaters (if present), and evaporative surfaces.

Capital cost of boiler modification varies widely with boiler configuration and fuel to be fired. Some coal conversion projects have expended as little as \$500,000 for converting industrial-scale boilers to coal, while the cost of other boiler modifications has exceeded \$15,000,000.

#### Case I: Gas and Oil to Coal (Utility)

In this case, two 400 MW boilers designed to fire gas and oil were converted to fire coal as a primary fuel, with oil backup. The overall plant site requirements for

the gas-fired units were an area measuring 1300 ft by 480 ft (396 m by 146 m), including turbine bays, steam generators and cooling tower. The same plant designed to fire coal required an area increased 20 times to accommodate the additional facilities required to use coal: storage yard, ash disposal area, flue gas treatment equipment, rail sidings, etc. The coal-fired furnace was nominally twice the size of the gas-fired furnace. Because of the ash content of the coal, more liberal boiler tube spacings were required. The furnace was elevated, widened, and deepened; and new superheater elements, economizer, and air preheater were added. The stack was relocated to accommodate flue gas treatment equipment.

#### Case II: Gas and Oil to Coal (Industrial)

In this case, two large industrial boilers designed to produce 650,000 lb/hr (82 kg/s) steam from firing natural gas were converted to burn a Western coal. The coal-fired unit required four times the volume of the natural gas unit.

#### Case III: Gas and Oil to Coal (Industrial)

In this case, a top-supported boiler designed to produce 400,000 lb/hr (50 kg/s) steam from firing natural gas was converted to coal firing by spreader stoker. The maximum steaming capacity was 200,000 lb/hr (25 kg/s), limited by the size of grate that could be installed. The following general modifications were included: furnace bottom pressure parts were modified to accommodate a hopper bottom suitable for ash disposal; a 16-ft (4.9-m) deep ash hopper was added;

feeders, bunkers, piping were added and windboxes modified to accommodate new burners; sootblowers were added; superheaters and air heaters were modified to prevent plugging caused by fly ash in the convection passes; gas cleanup and ash disposal equipment was added; additional fans and ductwork were added.

**Case IV: Gas and Oil to Coal (Industrial)**

In this case, a spreader stoker was retrofit to permit coal firing in a boiler originally designed for gas and oil. The bottom-supported gas-fired unit originally was rated to produce 300,000 lb/hr steam (87 MW). After conversion, it was derated to 150,000 lb/hr (43.5 MW).

**Case V: Restoration of Coal Capability (Industrial)**

In this case, a study was conducted to determine the technological and economic aspects of restoring coal capability to a boiler house at an Army ammunition plant. The three 125,000 lb/hr (15.7 kg/s) boilers that were designed to fire pulverized coal in the 1940s were converted to natural gas in the 1960s and mothballed in 1972. The study indicated that the design coal was unavailable. To accommodate the available coal required substantial interior boiler work. New burner and combustion management equipment was required, nearly all fans had to be either rebuilt or replaced, and the coal handling and storage system required complete rehabilitation. The study recommended replacing the antiquated water treatment system. Total cost of restoring coal capability was estimated to be \$7,500,000. Including equipment for removal of particulate and sulfur oxide pollutants from the flue gas, the cost could exceed \$20,000,000.

**Case VI: Coal-Convertible, Oil-Fired Boiler to RDF (Industrial)**

In this case a boiler designed in the 1940s to fire heavy fuel oil and to be convertible to coal is being modified to fire 100 percent RDF. The boiler is rated about 25,000 lb/hr (3.1 kg/s) steam. The RDF is once-shredded municipal solid waste and will be purchased for an estimated cost of \$0.68/MBtu (\$0.00064/J). To accommodate the RDF, the boiler had to be completely rebuilt. "Coal convertibility" in this case consisted of little more than an indication on the plant blueprints of approximately where a pit might be dug for bottom ash removal. In addition to boiler rebuilding, air pollution control and sophisticated RDF handling equipment had to be installed. Current estimates place the cost of this project at \$8,000,000.

**Case VII: Firing Coal and POL (Industrial)**

In this case, a coal-fired boiler rated at about 60,000 lb/hr (7.5 kg/s) steam was receiving nondesign (off-specification) coal and experiencing difficulty maintaining optimal combustion. This location also had a significant amount of waste oils, consisting mainly of lubricants and crankcase oil, which were being sold to a scavenger at a low price. Engineers experimented with firing the waste oils with coal on the traveling grate stoker and found that some coal could be conserved and, more importantly, that coal combustion could be improved. In this system, the oils are fed onto the coal just prior to its feeding into the boiler. An investment of less than \$10,000 was required for the oil transfer and handling system. This operation has been successful for several years.

## 5 COMBUSTION SYSTEMS II: BOILER REPLACEMENT

In some cases it may be necessary to replace existing boilers with units designed to fire coal rather than convert them. As indicated in the previous chapter, most gas- and oil-fired plants cannot be converted easily to coal-firing. This is particularly true for package boilers, but even boilers designed to fire coal may sacrifice some rating in reconversion. Moreover, although some boilers might be convertible to coal technically, they may be either technically obsolete or so old that a long future operating life cannot be guaranteed. Outlying package boiler plants are likely to be eliminated in the coal conversion effort, with their functions being taken over by large centralized systems. This chapter provides general technical and economic information on new coal-fired heating and power plants. The discussion includes ash removal systems, but not handling and storage, air pollution control, and salvage fuels, which are covered in separate chapters.

### Stokers

The two general classes of stokers are underfeed and overfeed, depending on the direction from which coal reaches the field bed. Types of underfeed stokers are single retort and multiple retort. Types of overfeed stokers are spreader and mass-burning, and members of the latter group are usually referred to by specific design: chain-grate, traveling-grate, and water-cooled vibrating grate.

Plant cost depends on the type of firing method selected, and this in turn depends largely on both the steam load profile at the location and the properties of the coal to be burned. Table 2 furnishes information on the general characteristics of stokers with respect to these variables, and Table 3 indicates the performance of stokers with respect to solid fuel properties. Vibrating-grate and multiple retort underfeed stokers have been omitted. Modern boiler technology now emphasizes the traveling grate and spreader stoker types, and these will probably be the most used firing technologies in Army systems, particularly in light of their high potential for firing salvage fuels.

Spreader stokers use a combination of suspension and bed burning (Figure 3). Coal is continuously distributed either by mechanical or pneumatic modes from the front to the rear of the furnace above a burning fuel bed. Ash falls from the continuously forward-moving grate into a hopper at the front of the furnace. Up to 50 percent of the burning can occur in suspension, but 20 to 25 percent is typical. As a result, higher particulate loadings in the flue gas occur, but this disadvantage is often outweighed by very fast response to load swings. Turndown generally extends from 20 percent to full load capacity, but minimum load can reach about 12 percent if provisions are made at the design stage.

A variety of grates can be used with the spreader stoker. The simplest and least expensive type of grate is the stationary grate, which must be cleaned manually. Uncooled grates accommodate boilers in the 5 to 30 MBtu/hr (1.4 to 8.8 MW) range but are rarely used; the boiler is so small that the necessary flue gas cleanup equipment cannot be justified economically. Similarly, dumping grates are used less and less, as air pollution laws have become more stringent. Continuous self-cleaning grates of the following types are favored: reciprocating, vibrating, and oscillating. Attainable heat release rates range up to 600,000 Btu/sq ft-hr (1 800 000 W/m<sup>2</sup>-hr). Use of a traveling grate in a spreader stoker will raise this to 750,000 Btu/sq ft-hr (2 400 000 W/m<sup>2</sup>-hr).

The reciprocating grate consists of lateral rows of overlapping grates which move the fuel bed forward. Frequency of the reciprocating cycle is synchronized with fuel and air supply. This grate can be used on boilers rated up to 75 MBtu/hr (22 MW), accommodates a wide range of bituminous and lignitic coals

without preparation other than sizing, and allows using shallow pits for floor-level ash removal. It therefore can be used in converted boilers where available ash removal space is small.

The vibrating grate differs from the reciprocating grate in that grate travel is by vibration, which is accomplished by an eccentric drive assembly mounted at the front end of the boiler. Frequency and duration of vibration cycles are automatically timed to respond to boiler load.

Oscillating grates can be adapted to boilers ranging up to 150 MBtu/hr (44 MW). The grate is inclined to the ash discharge end. Flexure plates impart motion that causes the grate to oscillate.

For high-efficiency operation, a continuously discharging grate such as the traveling grate is favored. Particularly because of its higher burning rates, the traveling grate is now the most popular grate configuration for spreader-stoker boilers rated more than about 65 MBtu/hr (19 MW). These grates continuously travel at wide range of coals and salvage fuels. Where possible, a traveling grate is preferable in converted boilers because of its high allowable heat release rates and capability to burn a variety of fuels.

Mass-burning stokers rely completely on bed-burning. Chain grate and traveling grate stokers are fundamentally the same, except that the links of the chain grate stokers are assembled so that they move with a scissor-like action at the return bend. The traveling grate resembles a continuous conveyor belt. In a typical mass-burning operation, coal is gravity-fed from the bunker to a hopper along the boiler front wall and enters the furnace after passing under an adjustable gate to regulate fuel bed thickness.

Chain- and traveling-grate stokers (Figure 4) can be used in boilers up to 200 MBtu/hr (58 MW) and are well suited to fire a wide variety of coals and salvage fuels. Screenings of 1.25 in. (31 mm) and less are normally used. Such stokers are, however, sensitive to strongly caking coals, which inhibit passage of under-fire air to the fuel bed and can result in lower efficiency because of unburned carbon being discharged to the ash pit. Use of strongly caking coals will also mean sacrificing responsiveness to rapid load swings when using chain- and traveling-grate stokers.

**Table 2**  
**General Stoker Characteristics\***

Capability	Spreader With Traveling Grate	Chain and Traveling Grate	Underfeed
Rapid load increase	1	3	3
Minimize carbon loss	3	3	3
Overcome coal segregation	3	4	4
Fire wide variety of coals	1	4	4
Fire fine coal	4	4	4
Good burnout at all loads	4	2	2
Minimal flyash in stack gases	4	2	2
Maintain steam load under poor operating conditions	2	4	4
Minimal maintenance	2	2	3
Minimal power consumption (stoker, auxiliaries)	2	2	2
Ash and cinder handling	1	2	3

\*1 - Excellent  
2 - Good  
3 - Fair  
4 - Poor

**Table 3**  
**Influence of Fuel Properties on Firing Method**

Solid Fuel Property	Solid Fuel Firing Method			Spreader Stoker
	Underfeed Single Retort	Underfeed Multiple Retort	Traveling Grate	
As-fired size consist	1	2	2	1
Moisture	3	3	4	3
Caking index	2	2	1	3
Ash fusibility	2	2	3	3
Grindability	4	4	4	4
Friability	3	3	3	3
Volatile matter	3	3	3	3
Fixed carbon	4	4	4	4
Ash content	3	3	2	3
Heating value	4	4	4	4
Ash viscosity	3	3	3	3
Ash composition*				
Sulfur**				
Chlorides**				

\*Affects fireside fouling; not important to combustion.

\*\*Important from corrosion standpoint, not vital to combustion.

Very Important 1  
Important 2  
Minor Importance 3  
Little Importance 4

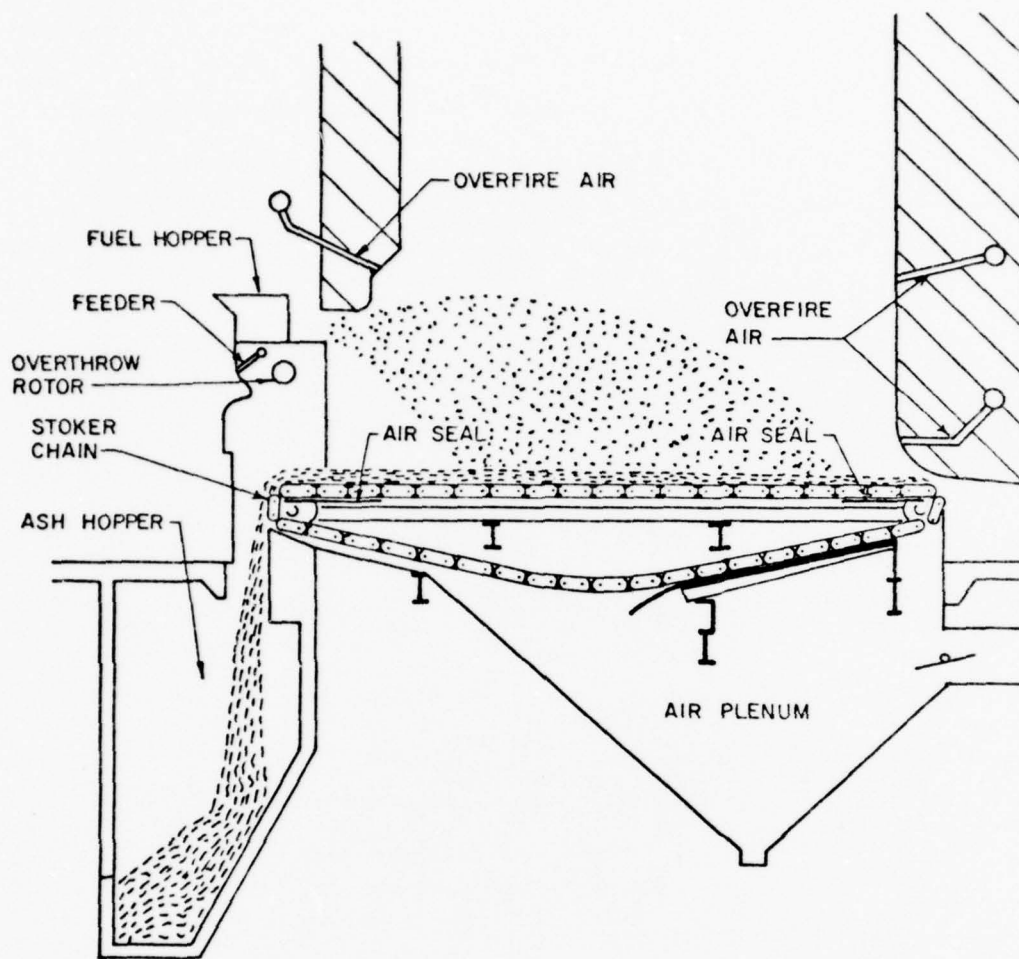

Figure 3. Spreader stoker with traveling grate.

#### Ash and Residue Removal

Three general categories of systems for removing bottom ash and fly ash are exhausters, pneumatic, and sluicing. For smaller plants (e.g., those operating at 250 MBtu/hr [73 MW] and less) steam exhauster systems are usually selected. Fuel ash content, method of firing, and the type and amount of ash collected determine specific selection. Coal ash content can be as high as 25 percent, and if certain salvage fuels such as RDF are fired with coal, the composite ash content can vary up to 40 percent. If the project developer is uncertain about what fuel(s) will be fired either in new or converted boilers, it is better to overestimate ash quantity to ensure sufficient handling capability.

The major elements of an exhauster system are as follows. A pneumatic conveyor moves ash from collect-

ing hoppers at stack and furnace to an air-lock receiver which separates the air and ash. An automatic discharge gate, usually of the swing type, channels the ash to a storage bin. Air from the separator still contains fine particles which must be removed before it is released to the atmosphere. An air washer accomplishes this. A steam, water, or mechanical exhauster can be used; the mechanical type is most efficient.

The mechanical exhauster is typically a motor-driven, rotary, positive-displacement blower. The purpose of the exhauster is to provide higher pressure at the pneumatic conveyor inlet end by reducing air pressure at the discharge end. To do this, the exhauster draws a large volume of air out of the receiver and separator, causing an influx of air that closes the swinging gates. The exhauster typically cycles for 90 seconds.

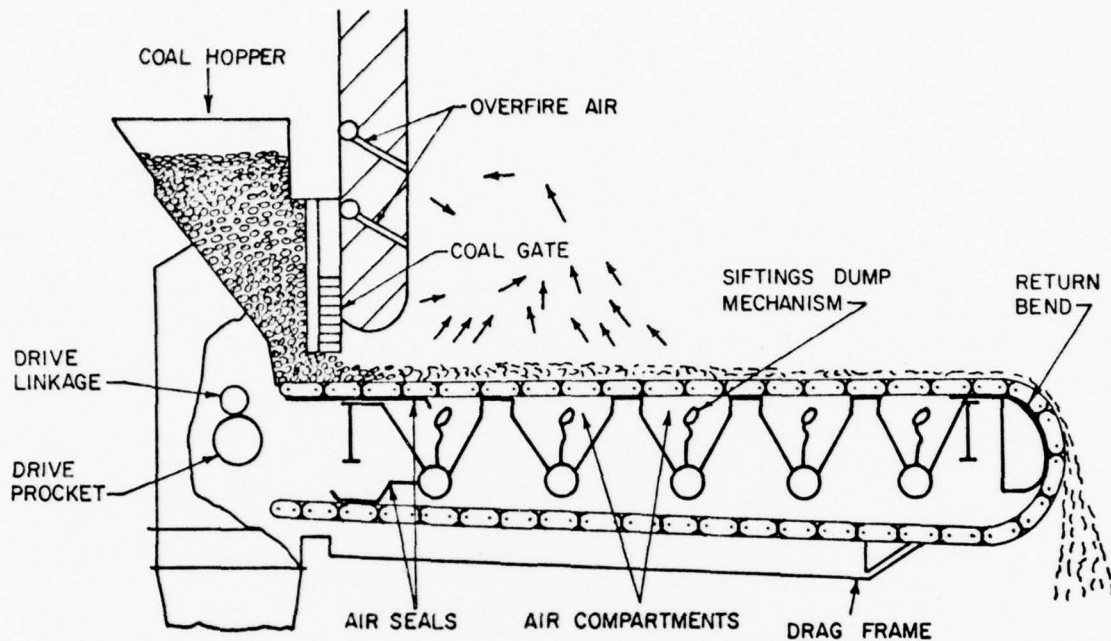

Figure 4. Chain grate stoker.

during which there is high velocity flow through the pneumatic line. When the exhauster shuts off, the vacuum breaks, and discharge gates swing open. The cycle is repeated automatically until all ash has been removed. It is manually activated by operators. The mechanical exhauster uses less energy than the other types, keeps air displacement constant, produces uniform flow velocity, and consumes power in proportion to the actual ash load being carried by the system.

Pneumatic systems are generally recommended for large plants. They have the advantage of high long-distance conveying capacity, which may be beneficial in retrofit applications where there is not enough room near the plant for an ash silo.

Wet systems are not recommended for industrial-scale plants, principally because of disposal and water treatment requirements, which can substantially increase overall operating costs. Even when wet scrubbers are used for air pollution control, separate dry systems are recommended for removing bottom ash, fly ash, and residue captured by dry particulate removal equipment.

Capital costs of exhauster removal systems, including outdoor silo, can range up to \$250,000, depending on quantity handled and, in retrofit applications, on construction difficulties. Important recurring cost items include electrical power and maintenance and repair.

Coal-fired boilers typically contain an ash hopper below the convective pass. In boilers of 50 MBtu/hr (14 MW) capacity and larger it is often cost-effective to reinject the fly ash captured at this stage (and sometimes also from downstream dust collectors) into the furnace in order to minimize carbon losses in fly ash. Either gravity or pneumatic reinjection systems can be used. It is often advantageous to adapt the overfire air system to reinject fly ash, since such systems can result in improved fuel use and increased overall plant efficiency.

#### Controls

Controls serve to modulate fuel supply, to maintain constant steam flow and pressure under varying loads, and to correct and maintain the optimal ratio of combustion air to fuel flow. Series control systems

control one variable (air or fuel) as the basis for adjusting the second variable (fuel or air). In parallel systems, a change in steam pressure initiates simultaneous changes in both fuel and air supply. Combination series-parallel control systems are usually set on steam flow to adjust the fuel feed rate. Parallel systems are favored in boilers rated up to 100 MBtu/hr (29 MW), and are gaining preference in larger industrial-scale units. Most parallel systems include control of the air-fuel ratio, and allow operating personnel to offset variations in fuel characteristics, combustion conditions, and key characteristics of final control elements.

Most installation central boilers were designed and built between 1935 and 1950, when pneumatic direct-connected analog control systems were state of art. Current technology involves integrated circuit digital and analog systems, and will probably shift entirely to digital controls in the 1980s. Such control systems are far superior to ones prevailing on installations and should be included not only in the design of new boilers, but also in conversion of existing ones.

Multiple fuel firing can involve either proportional or preferential firing of one fuel. In proportional firing, one fuel is usually base-loaded manually, while the other is modulated by the automatic total fuel controller. Preferential systems use two controllers; as demand increases, a secondary fuel computer calculates the differences between firing-rate demand and primary fuel flow, and the data are used as a set point for the secondary fuel controller. Hence, state-of-art technology can be used to control cofiring salvage fuels such as RDF and biomass.

While the combustion control system modulates air and fuel input in response to load changes, a burner management system is essentially an on-off control permitting firing at any load when conditions are safe. Modern burner systems include microcomputer technology which automatically checks certain boiler parameters simultaneously during startup and operation, and, based on the data, either permits operation to continue or initiates shutdown. Modern burner controls (including flame safety and safeguard systems) must be included in any conversion effort. Investment costs range between \$250,000 and \$800,000 per boiler.

#### Costs

Many capital cost elements associated with boiler replacement are site-specific and must be estimated

locally. Capital costs for traveling grate and spreader-stoker equipped boilers in the 25 to 200 MBtu/hr (7.2 to 58 MW) capacity range are between \$25,000/MBtu-hr (\$7300/MW) capacity to \$40,000/MBtu-hr (\$11,000/MW) capacity, with spreader-stoker systems at the high end. Additional costs of auxiliaries and buildings which must be considered can bring total new plant costs to between \$80,000/MBtu-hr (\$23,000/MW) capacity and \$125,000/MBtu-hr (\$36,000/MW) capacity, excluding air pollution control equipment.

Important recurring cost items are labor and maintenance and repair. Coal plant operation historically has been labor-intensive, with some industrial plant staffs numbering as many as 15 men per shift. Even with greater automation being incorporated into coal-fired steam-production systems, the personnel requirement is substantially higher than for gas- and oil-fired systems. Maintenance and repair costs are also greater, ranging from 3 percent to 4.5 percent of the capital cost of the plant. These figures exclude labor and maintenance and repair on air pollution control equipment, which is treated in Chapter 8.

## 6 SALVAGE FUELS

Salvage fuels available to numerous Army installations include refuse-derived fuel (RDF), waste wood (biomass), and waste POL. The quantity and quality of each varies with location. In developing a coal conversion project, availability of salvage fuels which might be cofired with coal should be assessed.

#### RDF

RDF is mixed solid waste beneficiated into a relatively homogeneous, highly cellulosic solid fuel. Use of RDF is determined by comparing the capital and life-cycle costs of (1) establishing a new heat-recovery incinerator plant and (2) processing mixed solid waste into RDF for use as a supplementary fuel in an existing boiler. Production of RDF usually entails at least two shredding stages, air classification, screening, and sometimes drying and pelleting. Army installations usually do not generate enough solid waste to economically justify the \$2,500,000 to \$8,000,000 investment required for an RDF production line. It is possible that installations will eventually be able to procure RDF from large civilian resource-recovery enterprises, although uncertainties regarding fuel specification and length of purchase agreement must be resolved before RDF can be widely used.

No experience has accumulated in firing RDF with either natural gas or fuel oil in installation-scale heating and power plants. It is probable that Army use of RDF will emphasize supplementing coal with pelleted or densified RDF (DRDF) in coal-fired boilers.

Use of DRDF in existing coal-fired boilers has yet to be demonstrated over the long term. Current EPA demonstration of cofiring DRDF and coal in a spreader stoker-equipped boiler in Hagerstown, MD, has amassed only 123 hours of experimental operating time at about half-load boiler operation. Firing DRDF in an existing boiler without major modification faces the same limitations discussed earlier for using low-quality coals. DRDF has a lower ash fusion temperature than nearly all coals, a calorific value of about 6900 Btu/lb (16 MJ/kg), and burns more rapidly and coolly than coal. Conclusive proof-of-concept demonstration of cofiring DRDF and coal in a converted boiler is 2 to 4 years away.

Conversely, new boilers can be and have been designed to fire RDF and coal. Most popular is the spreader stoker, where RDF is fired pneumatically and the coal mechanically. If a continuous, reliable supply of low-cost RDF is available, RDF can be considered a technically viable candidate for cofiring with coal in a new boiler. Major factors limiting Army use of RDF are procurement questions (fuel specification, length of agreement) discussed earlier.

#### **POL**

The firing of waste POL in existing gas-, oil-, and coal-fired boilers is technically feasible and is gaining operating experience rapidly. It is Army policy that POL be used wherever feasible. Such wastes can also be used as supplementary auxiliary fuel in heat-recovery incinerators. Air Force studies have shown that the following materials can be fired as a supplement in oil- and gas- or coal-fired boilers with minimal boiler modification: waste aviation piston-engine oil; mixtures of piston-engine oil, synthetic turbine lubricant, and hydraulic fluid; complex mixtures of piston-engine oil, synthetic turbine oil, hydraulic fluid, and Stoddard solvent; JP-4; and JP-4 contaminated with Avgas. The Army has successfully fired waste motor vehicle lubricant and crank-case oil; the materials are spread on lump coal just before it is fed to the stoker, leading to improved coal combustion.

Capital costs of waste petroleum oil and lubricant firing can range between \$500 and \$10,000 per boiler,

depending on the extent of burner modification required and the cost of handling the material. Savings of virgin fuel will usually pay back these relatively small investments of 1 to 4 years.

#### **Wood Waste (Biomass)**

Wood-fired boilers have a long history of successful operation, particularly in forest industry areas such as the Pacific Northwest. Many such systems suspension-fire hogged wood or bark, while some use grate-firing technology. A recent development is "Woodex"—hogged wood and/or sawdust pelleted in a mechanical extrusion mill.

Capital costs for installation-scale wood-fired boilers can range from \$800,000 to \$20,000,000, depending on capacity. Production cost of "Woodex" can range between \$25 and \$40/ton (including capital amortization), depending on plant capacity, purchase price, and transportation cost of raw material. Where a sufficient, continuous supply of forest waste is ensured, wood-firing systems can be economical on an Army installation. Cofiring wood waste with coal in new boilers both to conserve coal consumption and dilute sulfur oxide emissions to within compliance levels is also felt to be technically feasible, but no cost or long-term performance data are available to confirm this.

## **7 COAL GASIFICATION**

Coal gasification systems might be cost-effective at installations having a substantial number of package boilers that are designed to fire natural gas or oil. Coal-derived gas can easily be fired in existing large boilers designed to fire either heavy fuel oil or coal. In some instances, the installation will own and operate a coal gasification plant. As commercial interest in coal gasification continues its rapid growth, installations may function as a market for commercially produced gas.

Several coal gasification technologies exist, but little is known of their potential in installation-scale applications; most are in advanced development and have not yet been proven. Most commercial plants are relatively large-scale operations, while developing technologies are mostly pilot scale. Coal gasification systems usually produce a fuel with a heating value between 100 and 150 Btu/scf (3.7 to 5.6 MJ/m<sup>3</sup>).

High-Btu gasification systems produce a fuel with a heating value between 700 and 900 Btu/scf (26 to 33 MJ/m<sup>3</sup>), but are largely developmental. Commercial medium-Btu coal gasification systems produce a fuel with a heating value between 250 and 400 Btu/scf (9.3 to 14 MJ/m<sup>3</sup>).

#### Furnace Considerations

Several considerations are important when developing a coal gasification project, particularly when coal-derived gas is used in existing package boilers.

Recent studies have clearly demonstrated that when the heating value of the coal-derived gas is below about 300 Btu/scf (11 MJ/m<sup>3</sup>), there is usually difficulty in enlarging the burners or increasing the number of burners to fire the fuel in package boilers and maintain rated capacity. Below this heating value, the fuel pipes or ducts must be increased in size, which is difficult in compact package plants. Although it is sometimes necessary to enlarge the furnace when firing a low-Btu gas, units designed for coal and heavy fuel oil will probably have little difficulty firing gas with a heating value from about 250 Btu/scf (9.3 MJ/m<sup>3</sup>) upward. For these units, efficiency increases of up to 6 percent are possible, while efficiencies for gas- and oil-designed package boilers drop by as much as 20 percent when firing low-Btu gas. Finally, low-Btu gas requires costly upgrading to reach pipeline quality, while gas with a heating value of 300 Btu/scf (11 MJ/m<sup>3</sup>) and higher can be easily transported by pipe.

In developing a coal gasification project, use of medium-Btu gas should be considered, as it offers the highest potential for successful use in existing boilers.

#### Gasification System and Costs

A coal gasification system requires coal delivery, handling, and storage systems discussed earlier. It also includes a separate major process plant for production of coal-derived gas. The most commercialized process for producing medium-Btu gas from coal is the Koppers-Totzek process marketed by Koppers Engineering Company, Pittsburgh, PA.

This process uses an atmospheric pressure, oxygen-blown, entrained flow gasifier (Figures 5 and 6) and requires that coal be pulverized to 70 percent minus 200 mesh. A homogeneous mixture of oxygen and coal is injected into the gasification vessel through pairs of opposing coaxial burners arranged so that their jets converge. Either two or four such burner heads can be used. Volatiles and char are converted primarily to

carbon monoxide and hydrogen. About half the ash falls to a quench tank, and half is entrained in the product gas. The gas is spray-quenched to solidify molten ash and passes to a waste heat boiler which produces process steam. After further cooling, the gas is treated to remove fine particulate and sulfur. Typical gas compositions are shown in Table 4.

Capital costs of a plant for producing medium-Btu coal gas range between \$15,000,000 and \$45,000,000 for installation-scale systems. Important recurring costs are labor, electrical power, and maintenance and repair. Current plants have staffing of up to 20 persons per shift, and maintenance and repair costs can amount to as much as 6 percent of the installed capital cost of the plant. Disposal of byproducts can be an important factor where landfills are either not readily available or are reaching depletion. Specific annual cost data on applying this system on the installation scale are not available.

## 8 AIR POLLUTION CONTROL

Reducing emission of air pollutants to within compliant levels is one of the greatest challenges the Army faces in its coal conversion effort. The major pollutants to be dealt with under today's laws are particulate matter and the gaseous oxides of sulfur and nitrogen. While the burning of coal has a very long and firmly established history, the opposite is true in the case of separating these pollutants from stack gases at the high efficiencies generally required.

Besides being of recent development, many available air pollution control technologies are high in first cost, consume large quantities of electrical power, and require many operating personnel. For these reasons, it is usually not economical to convert or replace outlying small plants with coal-fired units. Even in the case of new, large, central coal-fired heating and power plants, the cost of sophisticated air pollution control technology sometimes can equal that of the new coal-burning system.

Technology for removal of particulate pollutants has a longer track record than that for sulfur and nitrogen oxides. Both electrostatic precipitators and baghouses (fabric filters) have been used successfully. This equipment usually is preceded by a cyclone

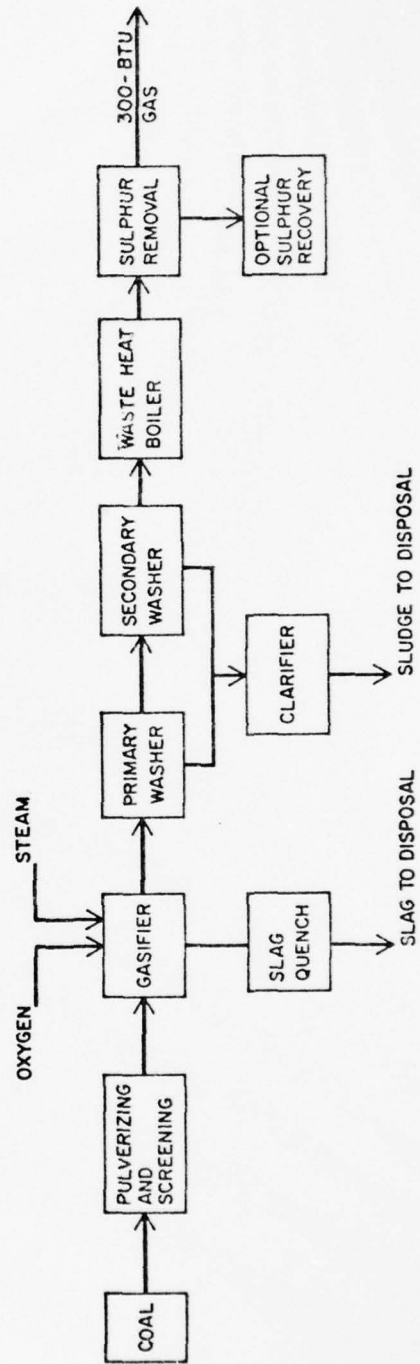

Figure 5. Koppers-Totzek coal gasification process.

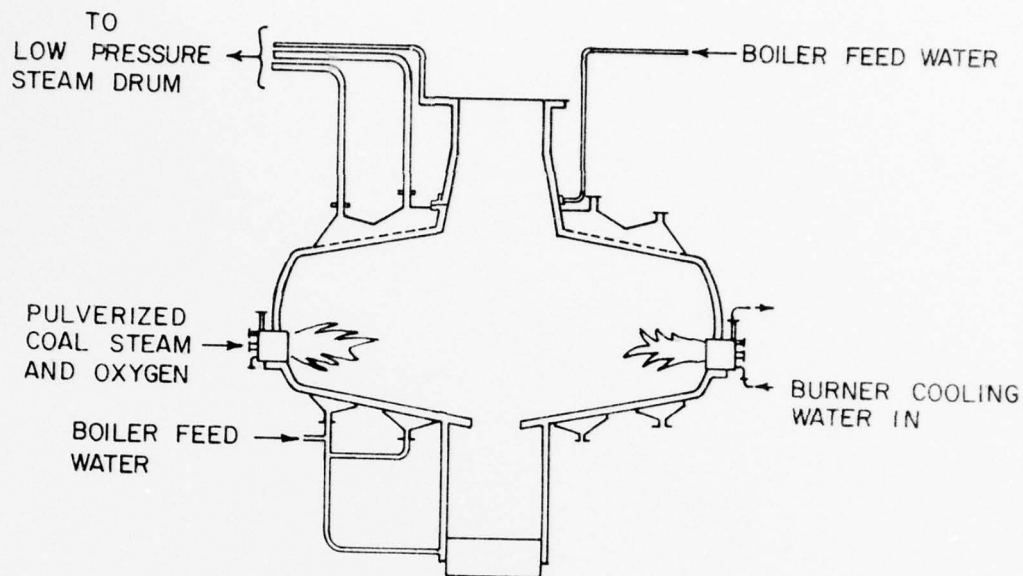

Figure 6. Koppers-Totzek coal gasifier.

Table 4  
Composition of Coal-Derived Gas  
From Koppers-Totzek Process

Item*	Regional Coal			
	Western	Illinois	Eastern	Eastern
CO	58.68	55.38	55.9	52.5
CO <sub>2</sub>	7.04	7.04	7.18	10.0
H <sub>2</sub>	32.86	34.62	35.39	36.0
N <sub>2</sub>	1.12	1.01	1.14	1.1
H <sub>2</sub> S	0.28	1.83	0.35	0.4
COS	0.02	0.12	0.04	—
CH <sub>4</sub>	—	—	—	—
C <sub>m</sub> H <sub>n</sub>	NA**	NA	—	—
H <sub>2</sub> O	—	—	—	—
S(gm/MBtu)	—	—	—	—
HHV(Btu/scf)	295	290	294	286

\* Volume Percent

\*\* NA-Data Not Available

separator to remove larger particles and permit flue gases to cool somewhat. Nevertheless, fabric filtration systems for coal-fired plants usually employ high-temperature-tolerant media such as fluorocarbon, which is among the most costly media marketed.

Scrubbers can also be used for particulate removal, but they are preferred for removal of gaseous pollutants. Most commercial and developing systems for sulfur oxide removal use scrubbers and a chemical medium such as lime, limestone, magnesium, or sodium to treat the sulfur.

Using scrubbers introduces into the already complex coal conversion situation the additional factors of water treatment and sludge disposal. Scrubbers on larger heating and power plants firing high-sulfur, high-ash coal will generate vast quantities of byproduct whose disposition can add up to \$2,500,000 to annual operating cost. Disposal alternatives include lined and unlined ponding, and mechanical dewatering. Water recirculating systems are preferred to conserve both water and land area. Capital costs of disposal systems can range from \$2,000,000 to \$10,000,000, with sophisticated lined ponding systems at the high end.

The future of air pollutant emission guidelines is very uncertain. The (draft) national energy strategy encourages scrubbing flue gases at all coal-fired plants. USEPA has proposed new guidelines requiring removal of 90 percent of sulfur in the flue gases, regardless of concentration. It is probable that new legislation will be introduced requiring efficient removal of specific particulate materials established as being hazardous or toxic. These factors will certainly impact upon the now competitive low-sulfur coal market. Moreover, they will strongly affect the viability of using salvage fuels (RDF, biomass, and POL) with coal both to dilute emission of certain pollutants to within compliance levels and to conserve coal.

These uncertainties pose serious difficulties for the designer and project developer alike. The project developer must obtain information on the sulfur and ash content of the fuel(s) most likely to be burned and on the probable firing method. For most stoker-firing technologies, nitrogen oxides emission is not expected to be a problem and, in the cases where it is, process controls generally will be usable to reduce nitrogen oxide concentration to compliance levels. Major challenges will be faced in reducing particulate and sulfur

oxides. In planning systems for the reduction of these pollutants, one must assume full load plant operation and compliance with the most stringent emission guidelines in effect at the plant location.

Cost of air pollution control equipment is perhaps the most powerful argument used by proponents of coal gasification systems, particularly in retrofit situations. Coal gasification can reduce emission of air pollutants from boilers by not allowing them to enter the boilers in the first place. This avoidance engineering measure must be justified by comparing the capital and life-cycle operating and maintenance costs of new gasification and retrofit emission control systems. Process and cost information on available emission control systems in the following paragraphs will assist the project developer in making this decision. Other costs are site-specific and must be estimated locally.

#### **Particulate Control**

Equipment for removing particulates from flue gases includes mechanical collectors, electrostatic precipitators and fabric filters (baghouses). Technical details and design guidance for implementing this equipment can be found in TM 5-815-1, *Air Pollution Control Design Manual* (DA, 1978). Only a brief description of this equipment is provided here.

Cyclone collectors are widely used particulate removal devices, and many Army boiler plants designed for coal have them installed. Two widely used types are shown in Figure 7. Particulate-laden gas passes tangentially into a cylindrical or conical chamber and exits upward through a central opening. The resulting vortex motion creates a strong centrifugal force field, in which the particles, by virtue of their inertia, separate from the carrier gas stream. They then migrate along the cyclone walls by gas flow and gravity and fall into a storage receiver. Depending on the carbon content of the fly ash, it may be reinjected into the boiler.

Capital costs of cyclones for industrial-scale plants range between \$15,000 and \$200,000 depending on particulate load, required efficiency, and retrofit problems. As a general rule, capital costs may be estimated at between \$1.80 and \$3.50 per actual cubic foot per minute (acfm) ( $\$0.00085$  and  $\$0.0016/m^3\text{-s}$ ) gas flow rate, where acfm ranges between 400 and 600 per MBtu-hr boiler heat input as coal. Total annual costs for operation and maintenance can be determined from Equation 3:

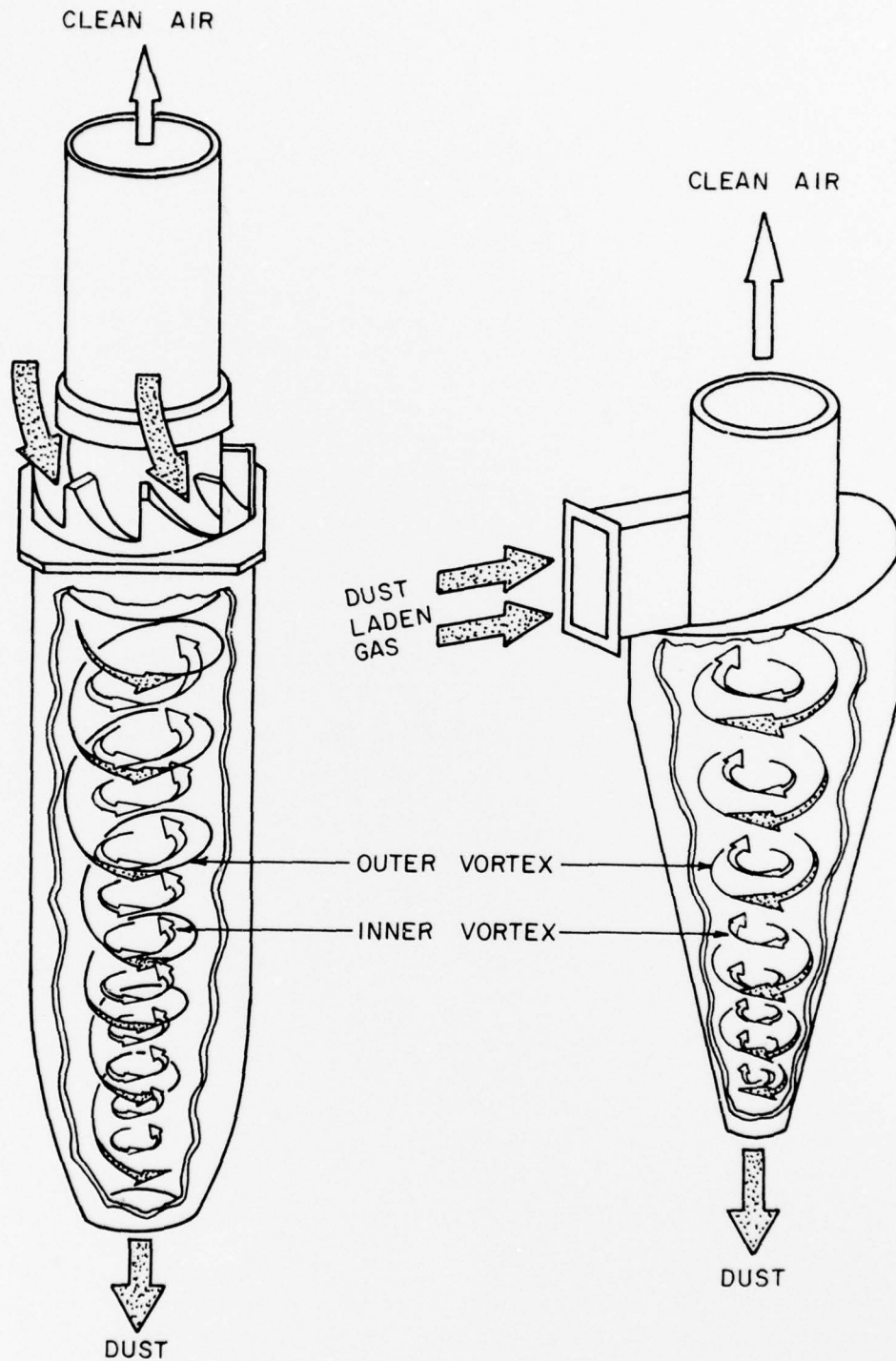

Figure 7. Typical cyclone configurations.

$$G = S \left[ \frac{0.7457 PHK + M}{6356 E} \right] \quad [\text{Eq 3}]$$

where

- G = annual O&M costs (dollars)
- S = design capacity (acfm)
- P = pressure drop (inches of water)
- H = hours per year operation (hr/yr)
- K = power cost (\$/kWh)
- E = fan fractional efficiency (dimensionless)
- M = annual maintenance cost (\$/acfm)

In using Equation 3, it should be noted that pressure drops, P, through these collectors usually range between 0.5 and 3.0 inches of water (120 and 745 Pa); that maintenance costs, M, typically range between \$0.02 and \$0.07 per acfm (\$9.40 and \$33./Mm<sup>3</sup>-s); and combined fan and motor efficiencies, E, average about 0.50.

In electrostatic precipitators, the force required to separate particles from the carrier gas results from an electric charge on the particles and the electric field within the precipitator (Figure 8). Particle charging takes place by the attachment of ions generated by an electrical corona. Generation of the corona involves application of high direct-current voltage between a small-radius wire and a cylindrical or plate electrode. Charged particles are attracted to an oppositely

charged plate or tube. Particles are removed to a collection hopper by vibrating or rapping the plate. Electrostatic precipitators collect particulates more efficiently than cyclones, and are particularly effective for capturing small particles. Because of their high particulate removal efficiency, precipitators are often used to precede those desulfurization systems which depend on particulate-free gas. Depending on the resistivity of the particles to charging, flue gas additives such as sulfur trioxide are used to achieve high collection efficiency.

Retrofitting a boiler plant with an electrostatic precipitator usually presents problems caused by the large size of the precipitator.

Capital costs of electrostatic precipitators range between \$4.25 and \$7.50 per acfm (\$0.002 and \$0.003/m<sup>3</sup>-s) gas flow and depend upon particulate load, removal efficiency, and retrofit problems. Equation 4 can be used to estimate annual costs.

$$G = S[JHK + M] \quad [\text{Eq 4}]$$

where

- J = power consumption (kW/acfm)

Values for J can range between 0.006 and 0.012, and values for M usually vary between \$0.120 and \$0.375 per acfm (\$56 and \$177/Mm<sup>3</sup>-s).

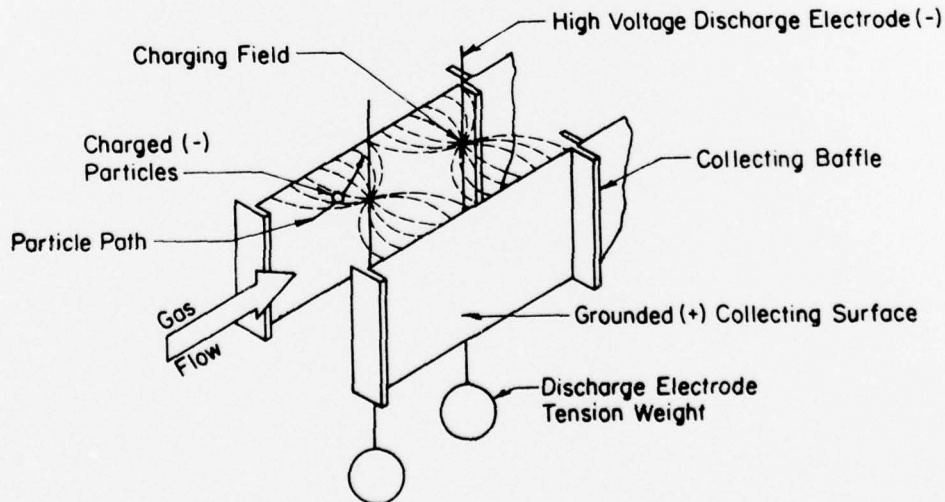

Figure 8. Schematic of surface type ESP.

Fabric filters (usually baghouses) have been used for many years to remove dusts from industrial process gases, notably in cement and metallurgical operations. They have been installed more recently on coal-fired boilers and have performed successfully. In a typical baghouse as shown in Figure 9, the fabric is formed into a vertically hung tube or sleeve closed at the top. As the stack gas is drawn through the bag, the collected dust forms a loosely deposited cake on the inside. Periodically the gas flow is diverted and the dust removed from the fabric either by agitation, partial bag collapse, air backflow or reverse air jet. Collected dust falls into a hopper from which it is hauled to disposal. Although many fabric materials and weaves are marketed, best service so far has been with woven glass fiber media coated with graphite and fluorocarbon polymers.

Fabric filters have an advantage over electrostatic precipitators in that their usually high collection efficiency is not affected by the chemical composition of the fly ash, nor by particle size. Thus, at locations where there are apt to be frequent changes or uncertainties in coal supply, baghouses are favored over precipitators. They can be used in series with those desulfurization systems which depend on particulate-free gases.

Retrofitting baghouses usually presents more problems than retrofitting precipitators, because baghouses are bulky.

Capital costs range between \$4.00 and \$7.50 per acfm (\$0.0018 and \$0.0035/m<sup>3</sup>-s), depending on size, particulate load, collection efficiency, media used, and retrofit problems. The latter can increase system cost up to four times the cost of the equipment. Equation 5 can be used to determine annual O&M costs:

$$G = S \left[ \frac{0.7457 \text{ PHK}}{6356 \text{ E}} + M \right] \quad [\text{Eq 5}]$$

Values of P can vary between 5 and 20 inches of water. Values of M can vary between \$0.125 and \$0.410 per acfm (\$59 and \$193/Mm<sup>3</sup>-s) depending largely on frequency of media repair and replacement.

#### Flue Gas Desulfurization

Unlike particulate removal technologies, those currently marketed for flue gas desulfurization do not have a long history of operation. Of the numerous processes available, five have attained a sufficient degree of commercialization to warrant considering

their use on Army installations: (1) lime slurry scrubbing, (2) limestone slurry scrubbing, (3) magnesia slurry scrubbing, (4) sodium solution scrubbing, and (5) catalytic oxidation. Generally, these processes depend on an initial particulate removal stage. Hence, plants that have baghouses, electrostatic precipitators, or other highly efficient particulate removal equipment can retrofit desulfurization equipment. It is expected that most installations will acquire total flue gas treatment systems when converting to coal. It is noteworthy that flue gas desulfurization systems are labor-intensive. In addition to the usual staff of a coal plant, as many as 15 additional man-years of labor may be required to operate and maintain a large, installation-scale flue gas desulfurization system, which is in reality a sophisticated chemical process plant.

In limestone slurry scrubbing systems, stack gases are washed with a recirculating slurry of limestone and reacted calcium salts in water using a two-stage scrubber system. Particulate and gaseous sulfur dioxide are removed simultaneously. Limestone feed must be wet-ground before it is fed to the scrubber effluent hold tank. Calcium sulfite and sulphate salts must be disposed of, and stack gases must be reheated. Figure 10 is a general process flow sheet of a typical limestone slurry scrubbing system. Table 5 furnishes capital cost and annual O&M data for the range of installation boiler capacities considered candidate for coal use.

Lime slurry scrubbing systems use a recirculating slurry of calcined limestone (lime) and reacted calcium salts in water to wash stack gases in a two-stage scrubber. General process flow is shown in Figure 11. As in limestone scrubbing, calcium sulfite and sulphate salts must be disposed of, and stack gas must be reheated. Table 6 furnishes capital cost and annual O&M data on this system for the range of installation boiler capacities considered candidate for coal use.

In magnesia slurry systems, particulate-free gases are washed in a recirculating slurry of magnesia and reacted magnesium-sulfur salts in water to remove sulfur dioxide. Baghouses, electrostatic precipitators or scrubbers can be used for first stage particulate removal. Makeup magnesia must be slaked and added to cover only handling losses, because sulfates formed in the process are reduced during regeneration. In this system, slurry from the scrubber can be dewatered, dried, calcined and recycled, during which concentrated sulfur dioxide can be sent to a contact sulfuric acid plant to produce 98 percent acid. Figure 12 shows a general process flow for the magnesia slurry system.

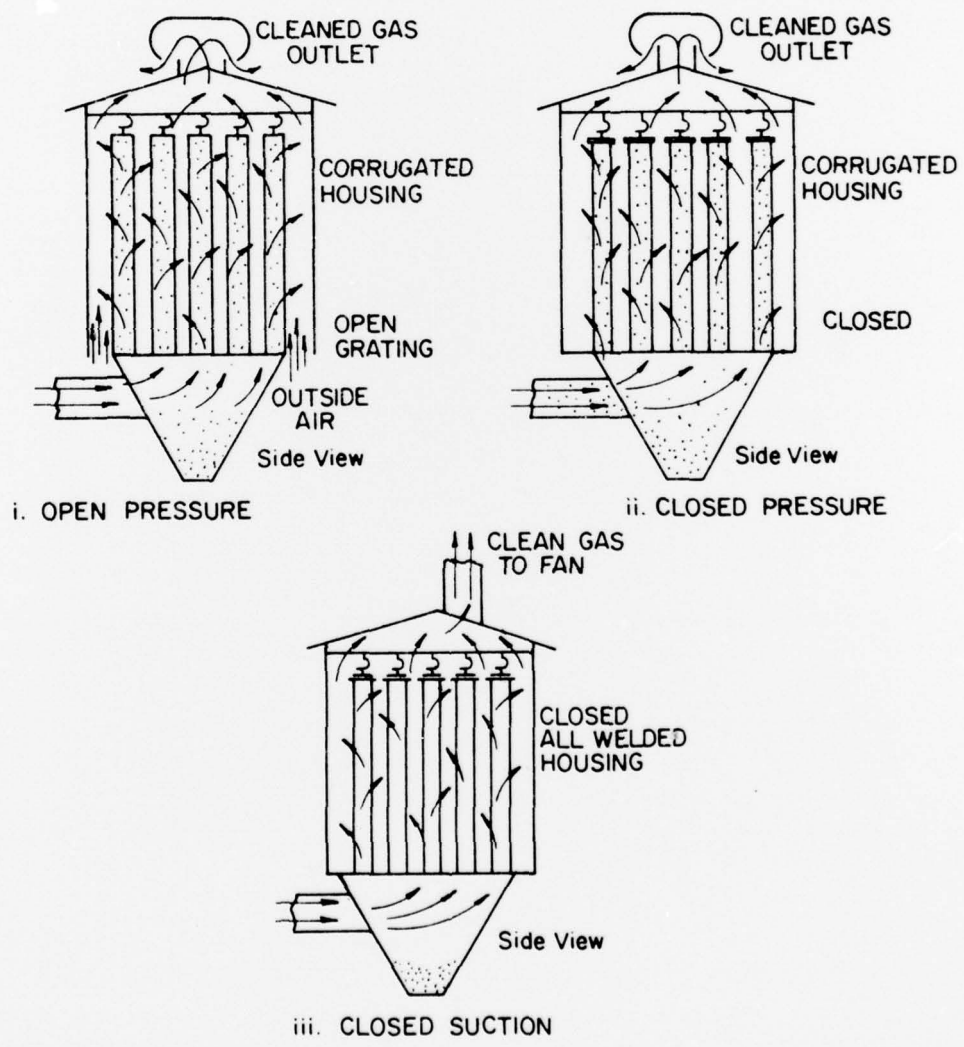

Figure 9. Typical baghouse construction.

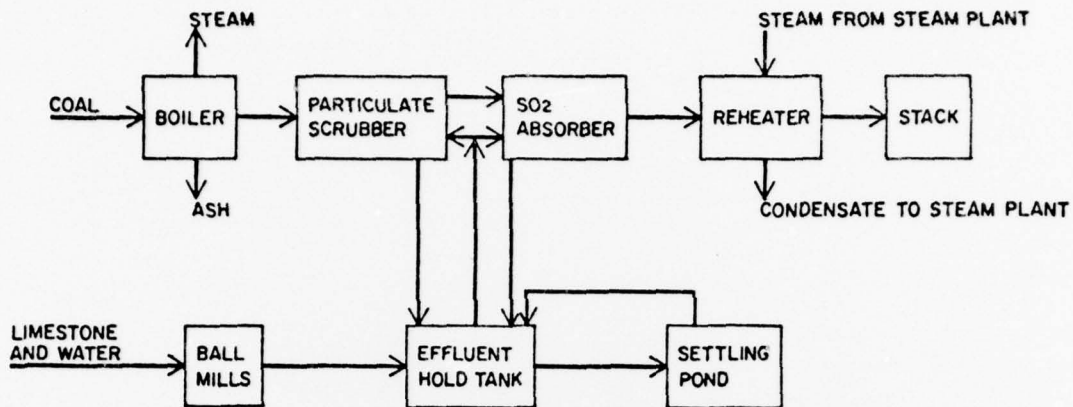

Figure 10. Limestone slurry process.

Table 5  
Cost Items: Limestone Slurry Process

Boiler Capacity (MBtu/hr)	Capital Cost (KS)	Limestone (kTon/Yr)	Operating and Supervision (Man-Hr/Yr)	Steam (kLb/Yr)	Process Water (kGal/Yr)	Electricity (kWh/Yr)	Maintenance Labor and Material* (KS/Yr)
25	1,874	9.8	1,525	27,603	14,020	4,409,770	169
50	3,002	15.7	2,443	44,223	22,461	7,065,060	270
75	3,955	20.7	3,218	58,263	29,592	9,308,030	356
100	4,810	25.2	3,914	70,852	35,986	11,319,200	433
125	5,598	29.3	4,555	82,461	44,882	13,173,900	504
150	6,337	33.2	5,156	93,345	47,410	14,912,800	570
175	7,037	36.8	5,726	103,661	52,650	16,560,800	633
200	7,706	40.3	6,270	113,514	57,654	18,135,000	694

\*9% OF INSTALLED CAPITAL COST

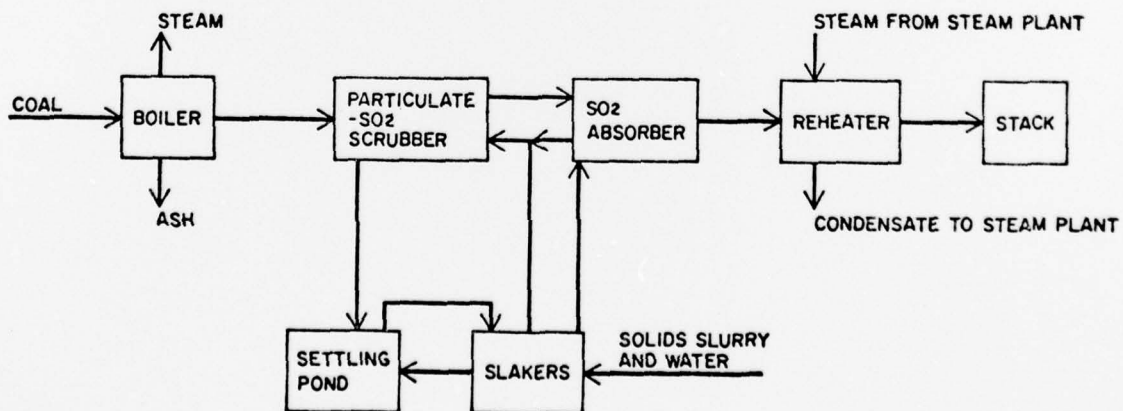

Figure 11. Lime slurry process.

Table 6  
Cost Items: Lime Slurry Process

Boiler Capacity (MBtu/hr)	Capital Cost (K\$)	Lime (kTon/Yr)	Operating and Supervision (Man-Hr/Yr)	Steam (kLb/Yr)	Process Water (kGal/Yr)	Electricity (kWh/Yr)	Maintenance Labor and Material* (K\$/Yr)
25	1,663	4.5	1,295	27,448	13,553	4,151,190	150
50	2,664	7.3	2,075	43,975	21,714	6,650,780	240
75	3,509	9.6	2,733	57,936	28,607	8,762,230	316
100	8,268	11.7	3,324	70,454	34,789	10,655,500	384
125	4,967	13.6	3,868	81,998	40,489	12,401,400	447
150	5,623	15.4	4,379	92,821	45,833	14,038,300	506
175	6,244	17.1	4,863	103,079	50,898	15,589,700	562
200	6,837	18.7	5,325	112,876	55,736	17,071,600	615

\*9% OF INSTALLED CAPITAL COST

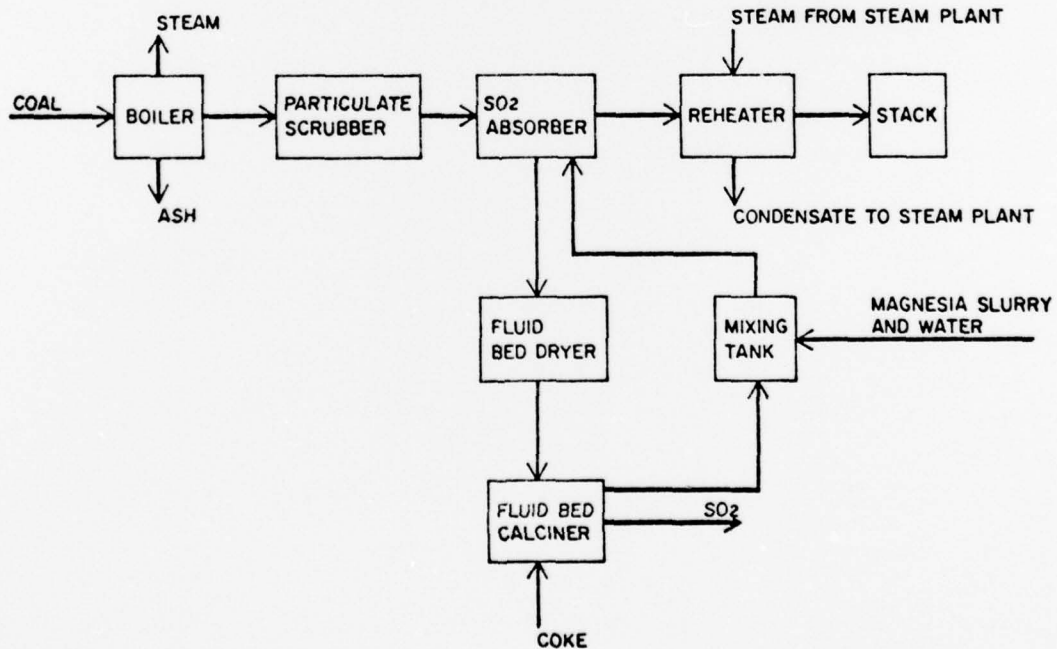

Figure 12. Magnesia slurry-regeneration process.

Table 7 provides capital cost and annual O&M data on this system for the range of installation boiler capacities considered candidate for coal use.

Like the magnesia system, sodium scrubbing depends on particulate-free flue gas. Baghouses, electrostatic precipitators, or scrubbers can be used for first stage particulate removal. This system scrubs the gas in a valve tray scrubber with a recirculating solution of sodium salts and water. Makeup sodium carbonate is added to cover losses resulting from handling and oxidation of sodium sulfite to sulfate. Water is evaporated from the scrubbing solution to crystallize and thermally decompose sodium bisulfite, driving off concentrated sulfur dioxide. The sodium sulfite is recycled to the scrubber, and the sulfur dioxide is reacted with methane for reduction to elemental sulfur. Stack gases must be reheated. Figure 13 shows a general process flow for the sodium scrubbing system. Table 8 provides capital cost and annual O&M data on this system for the range of installation boiler capacities considered candidate for coal use.

The catalytic oxidation system also depends on particulate-free gas, and established particulate removal technology can be used. In this system, sulfur dioxide is catalytically converted to sulfur trioxide, and available excess heat is recovered. Sulfur trioxide reacts with moisture in the stack gas to form sulfuric acid mist, which is scrubbed in a packed tower using a recirculating acid stream to yield 80 percent acid. A mist eliminator removes residual acid mist from stack gases before they are reheated and vented to the atmosphere. Process flow for the catalytic oxidation system is shown in Figure 14. Table 9 provides capital cost and annual O&M data on this system for the range of installation boiler capacities considered candidate for coal use.

Capital and annual data given for flue gas desulfurization systems exclude byproduct disposal, which must be estimated locally. Further information on these systems can be obtained from USEPA (limestone slurry), Chemical Construction Corporation (lime slurry), Chemico-Basic Corporation (magnesia slurry), Davy Powergas Company (sodium scrubbing), and Monsanto Corporation (catalytic oxidation).

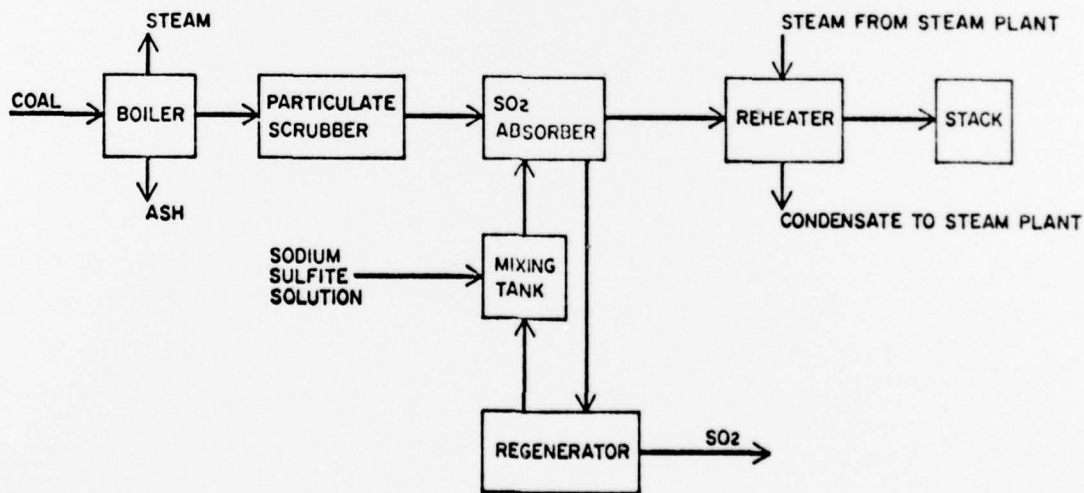

Figure 13. Sodium solution - SO<sub>2</sub> reduction process.

Table 7  
Cost Items: Magnesia Slurry-Regeneration Process

Boiler Capacity (MBtu/Hr)	Capital Cost (k\$)	Lime (Tons/Yr)	Magnesia Oxide (98%) (Tons/Yr)	Coke (Tons/Yr)	Catalyst (Liters/Yr)	Operating Labor and Supervision (Man-Hr/Yr)	Fuel Oil (Gal/Yr)	Steam (kLb/Yr)	Heat Credit (MBtu/Yr)	Process Water (kGal/Yr)	Electricity (kWh/Yr)	Maintenance Labor and Material* (k\$/Yr)
25	1,977	7.5	60.7	42.7	100.8	2,375	300,017	24,641	1,138	123,641	3,060,470	178
50	3,167	12.0	97.2	68.5	161.5	3,805	480,669	39,478	1,823	198,091	4,903,300	265
75	4,173	15.9	128.2	90.2	212.8	5,013	633,269	53,012	2,401	260,979	6,459,970	376
100	3,075	19.3	155.8	109.7	258.8	6,096	770,099	63,250	2,920	317,369	7,855,770	457
125	5,906	22.4	181.4	127.7	301.2	7,095	896,284	73,613	3,399	369,371	9,142,970	532
150	6,686	25.4	205.3	144.5	341.0	8,032	1,014,590	83,330	3,847	418,125	10,349,800	602
175	7,425	28.2	228.0	160.5	378.6	8,919	1,126,710	92,540	4,273	464,334	11,493,600	668
200	8,130	30.9	249.7	175.8	414.6	9,767	1,233,810	101,335	4,679	508,469	12,586,000	732

\*9% OF INSTALLED CAPITAL COST

Table 8  
Cost Items: Sodium Solution-SO<sub>2</sub> Reduction Process

Boiler Capacity (MBtu/Hr)	Capital Cost (k\$)	Lime (Tons/Yr)	Soda Ash (Tons/Yr)	Antioxidant (Lb/Yr)	Operating Labor and Supervisors (Man-Hr/Yr)	Natural Gas (MCF/Yr)	Steam (kLb/Yr)	Heat Credit (MLb/Yr)	Process Water (kGal/Yr)	Electricity (kWh/Yr)	Maintenance Labor and Material* (k\$/Yr)
25	2,292	7.5	521	17,773	2,817	28,537	119,743	3,521	557,520	4,154,650	206
50	3,620	12.0	835	28,475	4,513	45,721	191,844	5,642	893,225	6,656,330	330
75	4,838	15.9	1,100	37,515	5,946	60,236	252,750	7,433	1,176,800	8,769,540	435
100	5,883	19.3	1,337	45,621	7,231	73,251	307,361	9,039	1,431,070	10,664,400	529
125	6,847	22.4	1,557	53,096	8,416	85,253	357,724	10,520	1,665,560	12,411,800	516
150	7,751	25.4	1,762	60,104	9,527	96,506	404,940	11,908	1,885,400	14,050,000	598
175	8,607	28.2	1,957	66,746	10,580	107,171	449,692	13,224	2,093,760	15,602,700	775
200	9,426	30.9	2,143	73,091	11,585	117,580	492,436	14,481	2,292,780	17,085,800	848

\*9% OF INSTALLED CAPITAL COST

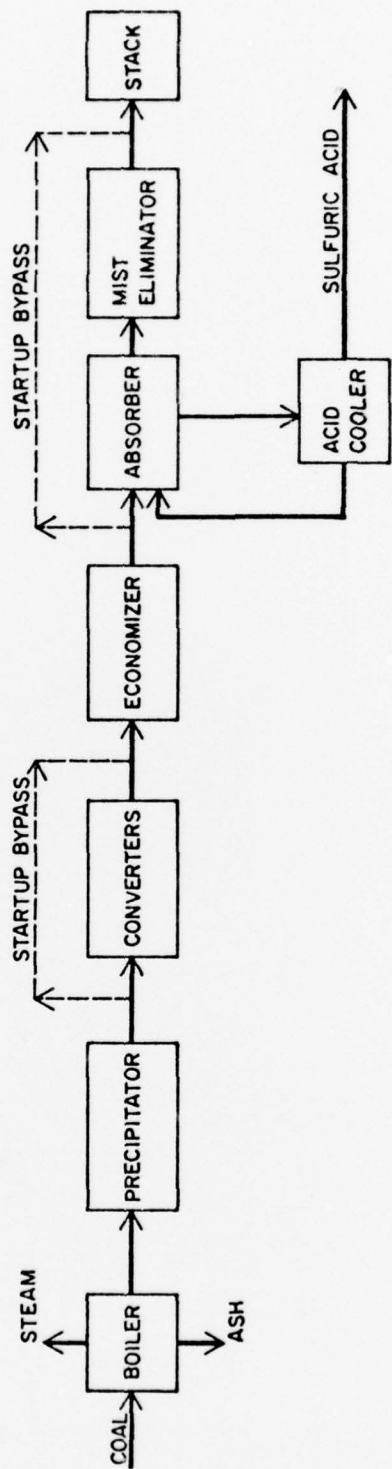

Figure 14. Catalytic oxidation process.

Table 9  
Cost Items: Catalytic Oxidation Process

Boiler Capacity (MBtu/Hr)	Capital Cost	Catalyst (Liters/Yr) (k\$)	Operating Labor and Supervision (Man-Hr/Yr)	Steam (kLb/Yr)	Heat Credit (MBtu/Yr)	Process Water (kGal/Yr)	Electricity (kWh/Yr)	Maintenance Labor and Material* (k\$/Yr)
25	2,805	4,517	6,332	7,704	42,592	13,508	3,902,490	252
50	4,494	7,236	10,144	12,342	68,238	21,641	6,252,330	404
75	5,921	9,534	13,365	16,261	89,902	28,512	8,237,290	533
100	7,200	11,594	16,253	19,774	109,327	34,673	10,017,100	648
125	8,380	13,493	18,916	23,014	127,241	40,354	11,658,500	754
150	9,486	15,274	21,413	26,052	144,035	45,680	13,197,300	854
175	10,534	16,962	16,962	28,931	159,953	50,728	14,655,800	948
200	11,535	18,575	26,039	31,681	175,157	55,550	16,048,800	1,038

\* 9% OF INSTALLED CAPITAL COST

#### CITED REFERENCES

- A Systematic Study of Viable Strategies for the Control of Sulfur Oxide Emissions From Army-Size Boilers* (U.S. Army Armament Readiness Command, Appropriation 2182040-08-1704, 1978).
- Army Energy Plan* (Department of the Army [DA], 1978).
- Empirical Cost Estimates for Military Construction and Cost Adjustment Factors* AR 415-17 (DA, 1977).
- Energy Production by Solid Waste Incineration*, Report FESA-RT-2036 (U.S. Army Facilities Engineering Support Agency, 1977).
- Hathaway, S. A., *Technology Evaluation of Army-Scale Waste-to-Energy Systems*, Interim Report E-110/ADA042578 (Construction Engineering Research Laboratory [CERL], 1977).
- Heating, Energy Selection and Fuel Storage, Distribution, and Dispensing Systems*, AR 420-49 (DA, 1976).
- Honig, E. M., Jr., and S. A. Hathaway, *Application of Modern Coal Technologies to Military Facilities*, Interim Report E-130/ADA055560 (CERL, 1978).
- Keystone Coal Industry Manual* (McGraw-Hill, 1976).

#### UNCITED REFERENCES

- A Field Test Using Coal: DRDF Blends in Spreader-Stoker-Fired Boilers* (Systems Technology Corporation, 1978).
- Air Pollution Control Design Manual*, TM 5-815-1 (DA, 1978).
- Assessment of the Capability of Firing Clean, Low Btu Gases in Existing Coal-, Oil-, and Gas-Fired Steam Generators* (Combustion Engineering, 1975).
- Coal Gasification Study* (Navy Civil Engineering Laboratory, 1977).
- Coles, W. F., and J. T. Stewart, "Considerations When Converting Industrial Plants to Coal Firing" (American Society of Mechanical Engineers, 1977).
- Combustion Additives for Pollution Control* (Battelle Laboratories, 1975).
- Combustion and Heat Recovery of Air Force Waste Petroleum Oils and Lubricants* (Air Force Weapons Laboratory, 1974).
- Combustion Engineering* (Combustion Engineering, Inc., 1968).
- Construction Criteria Manual* (Department of Defense, 1972).

- Cross, F., and H. Hesketh, eds., *Handbook for the Operation and Maintenance of Air Pollution Control Equipment* (Technomic Publishing Co., 1975).
- Detailed Cost Estimates for Advanced Effluent Desulfurization Processes* (Tennessee Valley Authority, 1975).
- Economic Analysis Handbook (P-442)* (Naval Facilities Engineering Command, 1975).
- Environmental Control Implications of Generating Electric Power from Coal* (Argonne National Laboratory, 1976).
- Frendberg, A., *Performance Characteristics of Existing Utility Boilers When Fired With Low Btu Gas* (Babcock and Wilcox Co., 1974).
- Guerrieri, S., "Achieving Self-Sufficiency With Coal," *Combustion* (April 1977).
- Gunning, G., "The U.S. Coal Situation—Long Range," *Combustion* (April 1977).
- Hathaway, S. A., and J. S. Lin, "Combustion Rates of RDF," *Proceedings of the Third International Conference on Environmental Problems in the Extractive Industries* (Wright Corp., 1977).
- Hollander, H., *Processed Refuse—A Salvage Fuel for Existing Boilers* (Gilbert Associates, 1977).
- McFarland, A., J. Stukel, S. Hathaway, J. Bachman, D. Bubenick, and M. Trutna, *Control Technology for Toxic and Hazardous Air Pollutants*, Report 75-6 (Illinois Institute for Environmental Quality, 1975).
- "Power from Coal," *Power* (February, March, April 1974).
- Richards, C. L., "Conversion to Coal—Fact or Fiction," *Combustion* (April 1978).
- Steam* (Babcock and Wilcox Co., 1972).
- Stokers for Industrial Boilers—Assessment of Technical, Economic, and Environmental Factors* (Battelle Laboratories, 1975).
- Whitacre, R., J. Farnsworth, and D. Mitsak, *The Koppers-Totzek (R-T) Process and Its Application to Industrial Needs* (Koppers Engineering, Inc., 1976).
- Woodyard, J., *Economics of Disposal and the Compilation of a Data Base for Standards Regulations of FGD Sludge* (SCS Engineers, 1978).

CERL DISTRIBUTION

EPL

Placating Arsenal  
ATTN: SMOJA-VP3

Director of Facilities Engineering  
APO New York 09827  
APO Seattle, WA 98749

BARCOM Still EUR  
APO New York 09710

USA Liaison Detachment  
ATTN: Library  
New York, NY 10007

West Point, NY 10996  
ATTN: Dept of Mechanics  
ATTN: Library

HQDA (SGRD-EDE)

Chief of Engineers  
ATTN: DAEN-MPO-U  
ATTN: DAEN-ASI-E (2)  
ATTN: DAEN-MPO-B  
ATTN: DAEN-MPO  
ATTN: DAEN-MPO-U  
ATTN: DAEN-MPZ-A  
ATTN: DAEN-MPR  
ATTN: DAEN-ROL  
ATTN: DAEN-PMS (7)

for forwarding to  
National Defense Headquarters  
Director General of Construction  
Ottawa, Ontario K1A0K2  
Canada

Canadian Forces Liaison Officer (4)  
US Army Mobility Equipment  
Research and Development Command  
Ft Belvoir, VA 22060

Div of Bldg Research  
National Research Council  
Montreal Road  
Ottawa, Ontario, K1A0R6

Airports and Const. Services Dir.  
Technical Information Reference  
Centre  
XADL, Transport Canada Building  
Place de Ville  
Ottawa, Ontario Canada K1A0N8

USA-CRREI

USA-WES  
ATTN: Concrete Laboratory  
ATTN: Library

Ft Belvoir, VA 22060  
ATTN: Kingman Building, Library  
ATTN: FESA

Ft Monroe, VA 23651  
ATTN: ATEN  
ATTN: ATEN-FE-U  
ATTN: ATEN-C-C/D. Lyon

Ft Lee, VA 23801  
ATTN: DRXMC-D (2)

Director  
HQ, US Army Garrison, Honshu  
ATTN: OFE  
APO San Francisco 96343

US Army/FESA  
Bldg 348  
Ft Belvoir, VA 22060

US Army Foreign Science & Tech Center  
ATTN: Charlottesville, VA 22901  
ATTN: Far East Office

6th US Army  
ATTN: AFKE-LG-E

US Army Engineer District  
New York  
ATTN: Chief, NADEN-E  
ATTN: Chief, Design Br.

Buffalo  
ATTN: Library

Pittsburgh  
ATTN: Library  
ATTN: Chief, Engr Div

Philadelphia  
ATTN: Chief, NAPER-D

US Army Engineer District  
Baltimore  
ATTN: Chief, Engr Div

Norfolk  
ATTN: Library  
ATTN: Chief, NADEN-M

Huntington  
ATTN: Library  
ATTN: Chief, ORHED

Wilmington  
ATTN: Chief, SAWEN-PP  
ATTN: Chief, SAWEN-D

Charleston  
ATTN: Chief, Engr Div

Savannah  
ATTN: Library  
ATTN: Chief, SASAS-L

Mobile  
ATTN: Chief, SAMEN-C

Nashville  
ATTN: Library

Vicksburg  
ATTN: Chief, Engr Div

Louisville  
ATTN: Chief, Engr Div

Detroit  
ATTN: Library

St. Paul  
ATTN: Chief, ED

Rock Island  
ATTN: Library  
ATTN: Chief, Engr Div

Chicago  
ATTN: Chief, NCCPD-ER

St. Louis  
ATTN: Library  
ATTN: Chief, ED-B  
ATTN: Chief, ED-D

Kansas City  
ATTN: Library (2)  
ATTN: Chief, Engr Div

Omaha  
ATTN: Chief, Engr Div

New Orleans  
ATTN: Library  
ATTN: Chief, LMNED-DG

Little Rock  
ATTN: Chief, Engr Div

Tulsa  
ATTN: Library

Fort Worth  
ATTN: Library  
ATTN: Chief, SWFED-D  
ATTN: Chief, SWFED-MA/MR

Albuquerque  
ATTN: Library

Los Angeles  
ATTN: Library

San Francisco  
ATTN: Chief, Engr Div

Sacramento  
ATTN: Library, Room 8307  
ATTN: Chief, SPKED-D

Far East  
ATTN: Chief, Engr Div

Japan  
ATTN: Library

Portland  
ATTN: Library

Seattle  
ATTN: Chief, NPSEN-PL-WE  
ATTN: Chief, NPSEN-PL-ER

Walla Walla  
ATTN: Library  
ATTN: Chief, Engr Div

Alaska  
ATTN: Library  
ATTN: Chief, NPADL-R

US Army Engineer Division  
Europe  
ATTN: Technical Library

New England  
ATTN: Library  
ATTN: Chief, NDED-T

North Atlantic  
ATTN: Library  
ATTN: Chief, NADEN-T

Middle East (Rear)  
ATTN: MEDED-T

South Atlantic  
ATTN: Chief, SAEN-TE  
ATTN: Library

Huntsville  
ATTN: Library (2)  
ATTN: Chief, HNDED-SR  
ATTN: Chief, HNDED-CS  
ATTN: Chief, HNDED-ME

Lower Mississippi Valley  
ATTN: Library

US Army Engineer Division  
Ohio River  
ATTN: Laboratory  
ATTN: Library  
ATTN: Chief, Engr Div

North Central  
ATTN: Library  
ATTN: Chief, Engr Div

Missouri River  
ATTN: Library (2)  
ATTN: Chief, Engr Div  
ATTN: Laboratory

Southwestern  
ATTN: Library  
ATTN: Chief, SWDED-IM

South Pacific  
ATTN: Chief, SPDED-IG

Pacific Ocean  
ATTN: Chief, PODED-D  
ATTN: Chief, PODED-P  
ATTN: Chief, PODED-MP  
ATTN: Chief, Engr Div

North Pacific  
ATTN: Chief, Ingr Div

Facilities Engineer  
Carlisle Barracks, PA 17013  
Ft Hood, TX 76544  
FORSCUM  
Ft Devens, MA 01433  
Ft George G. Meade, MD 20755  
Ft McPherson, GA 30430  
Ft Sam Houston, TX 78234  
Ft Carson, CO 80913  
Ft Lewis, WA 98433

USAECCOM  
Ft Monmouth, NJ 07703

TRADOC  
Ft Dix, NJ 08640  
Ft Belvoir, VA 22060  
Ft Lee, VA 23801  
Ft Gordon, GA 30905  
Ft McClellan, AL 36011  
Ft Knox, KY 40121  
Ft Benjamin Harrison, IN 46216  
Ft Leonard Wood, MO 65477  
Ft Sill, OK 73443  
Ft Bliss, TX 79916

USATCF  
Ft Eustis, VA 23604

DSCEPR  
West Point, NY 10996

USAIC (3)  
Ft Benning, GA 31905

USAAVNC  
Ft Rucker, AL 36361

CAC&FL (2)  
Ft Leavenworth, KS 66027

AMC  
Dugway, UT 84022

USACC  
Ft Huachuca, AZ 85613  
HQ, 1st Inf Div & Ft Riley, KS 66441  
HQ, 7th Inf Div & Ft Ord, CA 95941

AF/PREED  
Bolling AFB, DC 20332

AFESC/XRL  
Tyndall AFB, FL 32403

Little Rock AFB  
ATTN: 314/DEI (Mr. Gillham)

Everland AFB, NM 87112  
ATTN: Technical Library (2)

Naval Facilities Engr Command  
ATTN: Code 04  
Alexandria, VA 22304

Pentagon, CA 94041  
ATTN: Library Code (1804)  
ATTN: Moreell Library

Washington, DC  
ATTN: Blue Research Advisory Board  
ATTN: Transportation Research Board  
ATTN: Library of Congress (2)  
ATTN: Federal Aviation Administration  
ATTN: Dept of Transportation Library

Defense Documentation Center (DDC)  
Engineer's Societies Library  
New York, NY 10017

Commander  
SOUTHDIYNAVFACENCOM  
ATTN: CODE 1144/Sample  
2144 Melbourne St  
Charleston, SC 29411

Commander  
SOUTHDIYNAVFACENCOM  
ATTN: Code 403/Kennedy  
2144 Melbourne St  
Charleston, SC 29411

Commander  
LANTDIYNAVFACENCOM  
ATTN: Code 114/Gardner  
Norfolk, VA 23511

Commander  
NORTHDIYNAVFACENCOM  
ATTN: Code 1141/Gasbarro  
Building 77, Porter Avenue  
U.S. Naval Base  
Philadelphia, PA 19113

Commander  
CHESDIYNAVFACENCOM  
ATTN: Code 104.3/Shawyer  
Washington Navy Yard  
Washington, DC 20374

Commander  
NCBC  
NESO  
ATTN: Code 2512/Kneeling  
Port Hueneme, CA 93043

Commander  
HQNAVFACENCOM  
ATTN: Code 04  
200 Stovall Street  
Alexandria, VA 22332

Commander  
WESTDIYNAVFACENCOM  
ATTN: J. Shanling  
P.O. Box 727  
San Bruno, CA 94066

Commander  
HQNAVFACENCOM  
ATTN: Code 0320/Hurley  
200 Stovall Street  
Alexandria, VA 22332

Commander  
HQNAVFACENCOM  
ATTN: Code 044/Hildebrand  
200 Stovall Street  
Alexandria, VA 22332

Commander  
NCBC  
CEL  
ATTN: Code L63/Stone  
Port Hueneme, CA 93043

Commander  
NCBC  
ATTN: Library  
Port Hueneme, CA 93043

HQ USAF/PREM  
WASH DC 20330

HQ USAF/PREE  
WASH DC 20330

HQ USAF/PREVP  
ATTN: MAJ Frank Sanpet  
WASH DC 20330

CINCAD/DEV  
ATTN: LT COL Church Watkins  
Ent AFB, CO 80912

AFSC/DEEE  
ATTN: CAPT George Franklin  
Richards-Gebaur AFB, MO 64030

AFLC/DEPV  
ATTN: Mr. J. F. Hampton  
Wright-Patterson AFB, OH 45433

AFLC/DEMU  
ATTN: Mr. Robert Keggan  
Wright-Patterson AFB, OH 45433

AFSC/DEE  
ATTN: Mr. Martin Noland  
Andrews AFB, DC 20334

ATC/DEPV  
ATTN: Mr. A. E. Cullins  
Randolph AFB, TX 78148

3800 ABW/DEE  
ATTN: Mr. Ralph Stanford  
Maxwell AFB, AL 36112

CINCSAC/DEV  
ATTN: LT COL E. Hanson  
Offutt AFB, NB 68113

ATC/DEMU  
ATTN: Mr. Bernard Lindenberg  
Randolph AFB, TX 78148

AAC/DEV  
ATTN: Mr. R. Cameron  
APO Seattle 98742

MAC/DEE  
ATTN: Mr. Wayne Caughman  
Scott AFB, IL 62225

CINCPACAF/DEV  
ATTN: Mr. Richard Okamura  
APO San Francisco, CA 96274

TAC/DEEV  
ATTN: Mr. Gil Burnett  
Langley AFB, VA 23065

USAFSS/DEMU  
ATTN: Mr. John Hale  
San Antonio, TX 78241

CINCUSAFE/DEPV  
ATTN: MAJ Robinson  
APO New York 09012

AFRES/DEMM  
ATTN: Mr. James Rachal  
Robins AFB, GA 31098

USAF/DEV  
ATTN: COL D. Reaves  
USAF Academy, CO 80840

AFESC/RDVM  
ATTN: MAJ R. Olfenbuttel (2)  
Tyndall AFB, FL 32403

Hathaway, Stephen A

Project development guidelines for converting Army installations to coal use /  
by S. A. Hathaway, M. Tseng, J. S. Lin. -- Champaign, IL : Construction Engineering  
Research Laboratory ; Springfield, VA : available from National Technical Information  
Service, 1979.

38 p. : ill. ; 27 cm. (Interim report ; E-148)

I. Coal. I. Tseng, M. II. Lin, Jeng Shyan. III. Title. IV. Series: U.S.  
Construction Engineering Research Laboratory. Interim report ; E-148.