

AD-A068 028

FOREST PRODUCTS LAB MADISON WIS  
IMPROVED SAWING ACCURACY DOES HELP. (U)  
1979 A R STERN, H HALLOCK, D W LEWIS  
FSRP-FPL-320

F/G 11/12

UNCLASSIFIED

NL

| OF |  
AD  
A068028

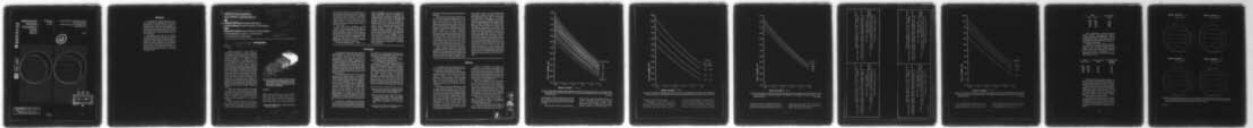

END  
DATE  
FILMED  
6-79  
DDC

AD A 068028

IMPROVING  
SAWING  
ACCURACY  
DOES  
HELP

RESEARCH  
PAPER  
FPL 320

U.S. DEPARTMENT OF AGRICULTURE  
FOREST SERVICE  
FOREST PRODUCTS LABORATORY  
MADISON, WIS.

1979

12

DDC FILE COPY

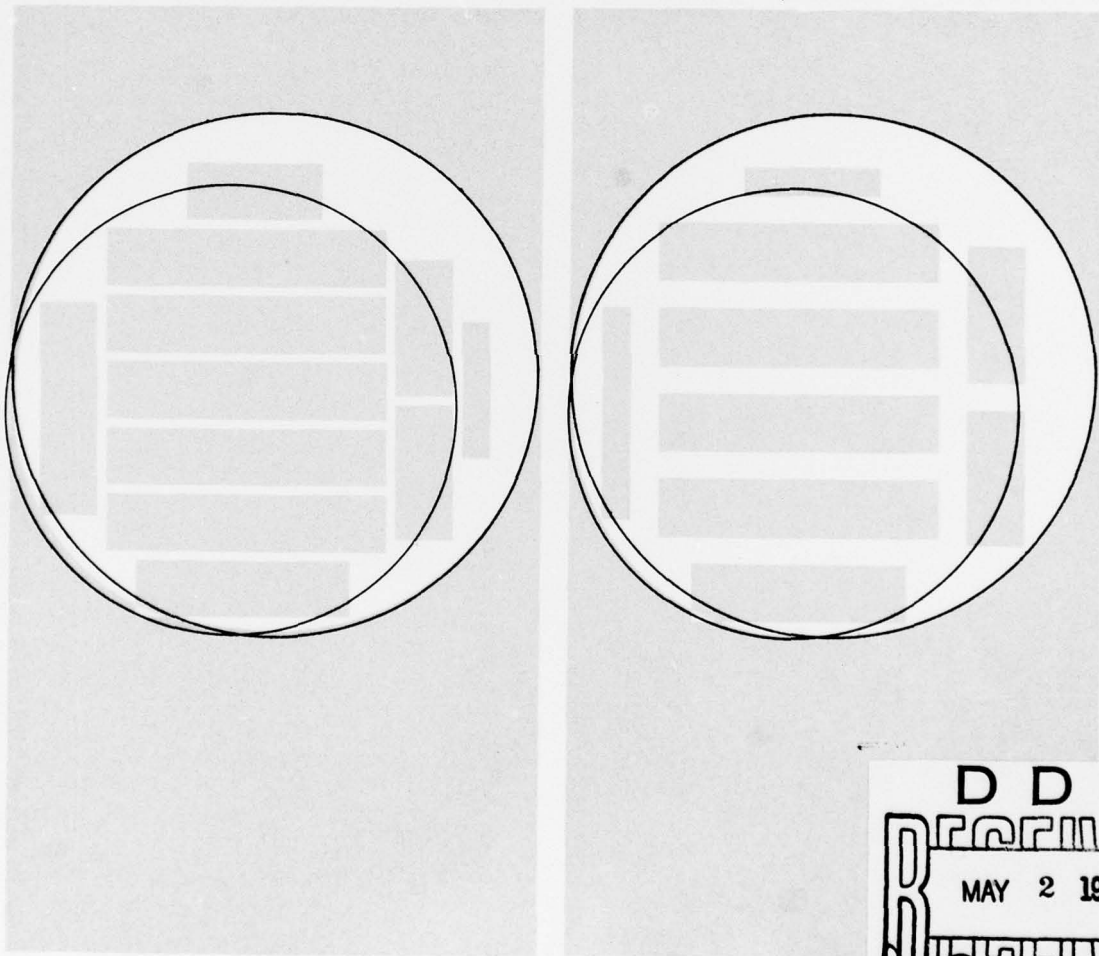

DDC  
RECEIVED  
MAY 2 1979  
B

DISTRIBUTION STATEMENT A  
Approved for public release;  
Distribution Unlimited

79 04 25 114

## Abstract

The relation of sawing accuracy to lumber recovery was studied using the *Best Opening Face* computer sawing program to mathematically simulate log breakdown as practiced by a major segment of the North American lumber industry. Sawing accuracy is a combination of sawing variation and lumber oversizing.

An analysis was made for 16 sawkerf combinations and the cant sawing method. The results show that exponentially larger increases in lumber yield can be expected as sawing accuracy increases. This increase in yield, with no additional raw material consumed, tends to compensate for the exponentially increasing costs of improving sawing accuracy.

⑥ IMPROVED SAWING ACCURACY DOES HELP.

⑨ Forest service research paper

⑩ Abigail R. Stern, Computer Specialist  
Hiram Hallock, Forest Products Technologist

⑪ 1979

David W. Lewis, Forest Products Technologist  
Forest Products Laboratory, Forest Service  
U.S. Department of Agriculture

⑫ 15p

Introduction

⑭ FSRP-FPL-320

Sawing accuracy is one factor influencing the amount of lumber recovered from a log and is expressed as a combination of sawing variation and lumber oversizing. Sawing variation is a measure of the mechanical precision in manufacturing lumber thicknesses and widths. Minimum size requirements for rough, green, softwood lumber are determined by taking the required final, dry-dressed lumber dimensions and adding allowances for planing and shrinkage (fig. 1). The target size of the lumber is determined by adding an additional allowance which represents sawing variation. Any additional thickness or width in excess of the target size is oversizing. Thus, sawing accuracy may also be defined as the difference between the required size and the actual size. An excess of sawing variation or any oversizing will result in lower lumber recovery.

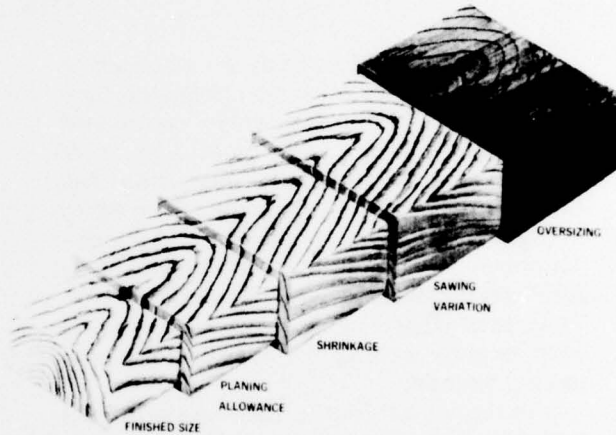

Figure 1.--The size of rough lumber includes allowances for the dressed lumber item, planing allowance, shrinkage, and sawing variation. Additional wood is oversizing and unnecessary.

(M 146 393)

Some mills produce lumber with a target size less than that required to surface satisfactorily according to the grading rule. This has the effect of increasing lumber recovery. Without comment on the advisability of this procedure, it is not a part of this study.

These mills produce more than 6 billion board feet yearly, or approximately 20 percent of the annual softwood production in the United States. Two factors evaluated were sawing variation and lumber oversizing.

During the past 4 years, the U.S. Forest Service has used the Sawmill Improvement Program (SIP) to evaluate the processing efficiency of more than 600 softwood sawmills.

<sup>1</sup> Maintained at Madison, Wis., in cooperation with the University of Wisconsin.

141 700 Gu

70 04 25 114

The results indicate the tremendous differences that exist between mills. For example, sawing variation ranged from  $\pm 0.025$  to  $\pm 0.534$  inch with a mean of  $\pm 0.165$ . Oversizing ranged from 0.0 to 0.288 inch with a mean of 0.077. It is obvious that almost all sawmills could benefit from closer control of sawing accuracy.

Just how much additional lumber recovery can be expected as sawing accuracy increases? This question has not previously been answered, yet the relationship of sawing accuracy to yield influences the decisions of sawmill management with regard to selecting and investing in new equipment. This relationship also influences equipment maintenance programs.

The Best Opening Face (BOF).<sup>2,3,4</sup>

system developed at the U.S. Forest Products Laboratory, uses the computer to mathematically simulate individual log breakdown and to determine maximal sawing patterns. BOF has made it possible to evaluate the effect of sawing accuracy on lumber recovery for a given set of mill conditions. This is possible because the BOF system accepts all sawmill variables, including sawing accuracy, and exactly models the sawing process for any log to obtain the best lumber recovery within the constraints imposed by the variables. Two or more degrees of sawing accuracy can be tried with the model, and the ratio of the lumber recoveries accurately reflects expected yield differences if applied in an actual milling situation.

---

## The Study

All aspects of the study were related to the production of softwood dimension lumber; sawing accuracy was expressed numerically in this study as the sum of sawing variation and lumber oversizing. The 11 sawing accuracy levels ranged from 0.0 to 0.5 inch by 0.05-inch increments. The logs--ranging in diameter from 4.8 to 20.5 inches by 0.05-inch increments--were 16 feet long with 2 inches of taper. Each log was "sawn" using each level for sawing accuracy and the cant sawing method.

In the United States, cant sawing is the method most widely used in converting small softwood logs to construction lumber. In this method, the log is sawn in two planes. At the first breakdown by the headsaw--which may be a conventional carriage plus circular or band headrig, a twin or quad band headrig, or even a frame saw-- , side lumber and a cant are produced. The cant then passes to a second machine, often a rotary gang, where it is sawn in a plane perpendicular to the initial breakdown. The first breakdown is usually referred to as vertical and the sawing of the cant as horizontal (fig. 6).

In this study, in addition to the diameter and sawing accuracy variables, all logs were "sawn" with all combinations of four vertical and four horizontal kerfs--0.125, 0.188, 0.250,

and 0.375 inch. These kerfs and their combinations are representative of the range of kerf widths used in the United States.

All logs and cants were sawn full taper, that is, parallel to one side of the log.

Cant breakdown equipment, such as a rotary gang, is normally equipped with a guide (fence) against which one of the round edges of the cant is alined for transport through the saws. The setting of this fence with reference to the saws is usually fixed for any given machine. Also, in most mill operations cants of nominal 4- and 6-inch thickness would be processed by one rotary gang and 8-, 10-, and 12-inch cants by another. Because the curvature on the outside of the cants varies with diameter, the setting of the fence for each gang is normally

---

<sup>2</sup> Hallock, H., and D. W. Lewis. 1971. Increasing softwood dimension yield from small logs. USDA For. Serv. Res. Pap. FPL 166. For. Prod. Lab., Madison, Wis.

<sup>3</sup> Hallock, H., and D. W. Lewis. 1973. Best Opening Face for second-growth timber. Chapt. 4, *In Modern Sawmilling Techniques: Vol. 1, Proceedings of the First Sawmill Clinic* (Portland, Oreg., Feb. 1973). Miller-Freeman Publications, Inc., San Francisco, Calif.

<sup>4</sup> Lewis, D. W., and H. Hallock. 1974. Best Opening Face Programme. Austral. For. Ind. J 40(10):12-31.

different. These practices were duplicated in the study.

The fixed fence had two positions--one for 4- or 6-inch cants and another for 8-, 10-, or 12-inch cants. Cants 4 inches thick were sawn from logs 4.80 to 8.50 inches in diameter while 6-inch cants were from logs 8.55 to 10.50 inches in diameter. The fence position for these cants was such that a full-length nominal 2 by 4 would be produced from a 4-inch cant cut from a 4.8-inch-diameter log. Cants 8 inches thick were sawn from logs 10.55 to 13.50 inches in diameter, 10-inch cants from logs 13.55 to 16.50 inches in diameter, and 12-inch cants from logs 16.55 to 20.50 inches diameter. The fence setting for these larger cants was such that a full length 2 by 6 would be produced from a 8-inch cant cut from a 10.55-inch-diameter log.

Other conditions specified in the BOF simulation were as follows: All lumber was edged for the longest piece obtainable from the flitch, allowing a maximum of 25 percent wane for both width and thickness in accordance with the National Grading Rule.

The smallest piece of lumber saved was nominally 4 inches wide and 8 feet long. Planing allowance was  $\frac{3}{32}$  inch; 3 percent was assumed for shrinkage to 15 percent moisture content; and planed lumber sizes were those specified by the American Softwood Lumber Standard PS 20-70 (ALS). Although sawmill machinery normally has mechanical constraints on transverse saw and log incremental movement, none were used in the study because to have done so might have precluded finding a maximum recovery solution. Both nominally 1- and 2-inch lumber were cut in the vertical plane, but the 1-inch lumber was limited to the first cut on the log and possibly the last cut, if in so doing the recovery was higher than would result from a 2-inch piece. On the cant (horizontal plane), the 1-inch lumber was limited to the last cut opposite the opening face if it proved advantageous compared to a final 2-inch cut. All other lumber was 2 inch. Widths cut were nominal 4, 6, 8, 10, and 12 inches.

## Results

The lumber yield in board feet for each 1-inch diameter class was calculated as the average yield of the 20 logs in the class.

Figure 2 shows the effect of decreasing sawing accuracy on the expected lumber yield for each of the 16 sawkerf combinations. Yields represent the combined total of one log from each 1-inch diameter class. For all kerf combinations, yield increases exponentially as sawing accuracy improves.

The effect of declining sawing accuracy on yield for the narrowest, the widest, and two intermediate kerf combinations is shown in figure 3. As would be expected, yields from sawing with both vertical and horizontal kerfs of 0.125 inch are appreciably higher than with comparable kerfs of 0.375 inch. With respect to the two intermediate kerf combinations (0.375 vertical and 0.125 horizontal, and 0.125 vertical and 0.375 horizontal) increasing the width of the horizontal kerf reduces yield more than does increasing the vertical kerf.

Figure 4 illustrates the results of changing only the vertical or headsaw kerf and the sawing accuracy while holding the horizontal or cant sawing kerf constant. The rather small spread between the four vertical kerf curves is again evidence of the relatively lesser effect of the headrig kerf when cant sawing logs in this diameter range.

When the headsaw kerf is unchanged but the cant sawing kerf and sawing accuracy are changed, the vertical spread of the curves is much greater (fig. 5). The basic cause of the differences between the spread of the curves in figures 4 and 5 is that, in the cant sawing of logs of these (and probably all) diameters, substantially more lumber is produced from the cant than from the log.

Evident also in both figures 4 and 5 is that any specific increase or decrease in either kerf width has a relatively constant and predictable effect on yield.

An example (fig. 6) shows the effect on yield in terms of the actual lumber items, as well as total board footage when sawing a 12-

Section	<input checked="" type="checkbox"/>
action	<input type="checkbox"/>
	<input type="checkbox"/>
<b>PER LETTER</b>	
TY CODES	
SPECIAL	

A

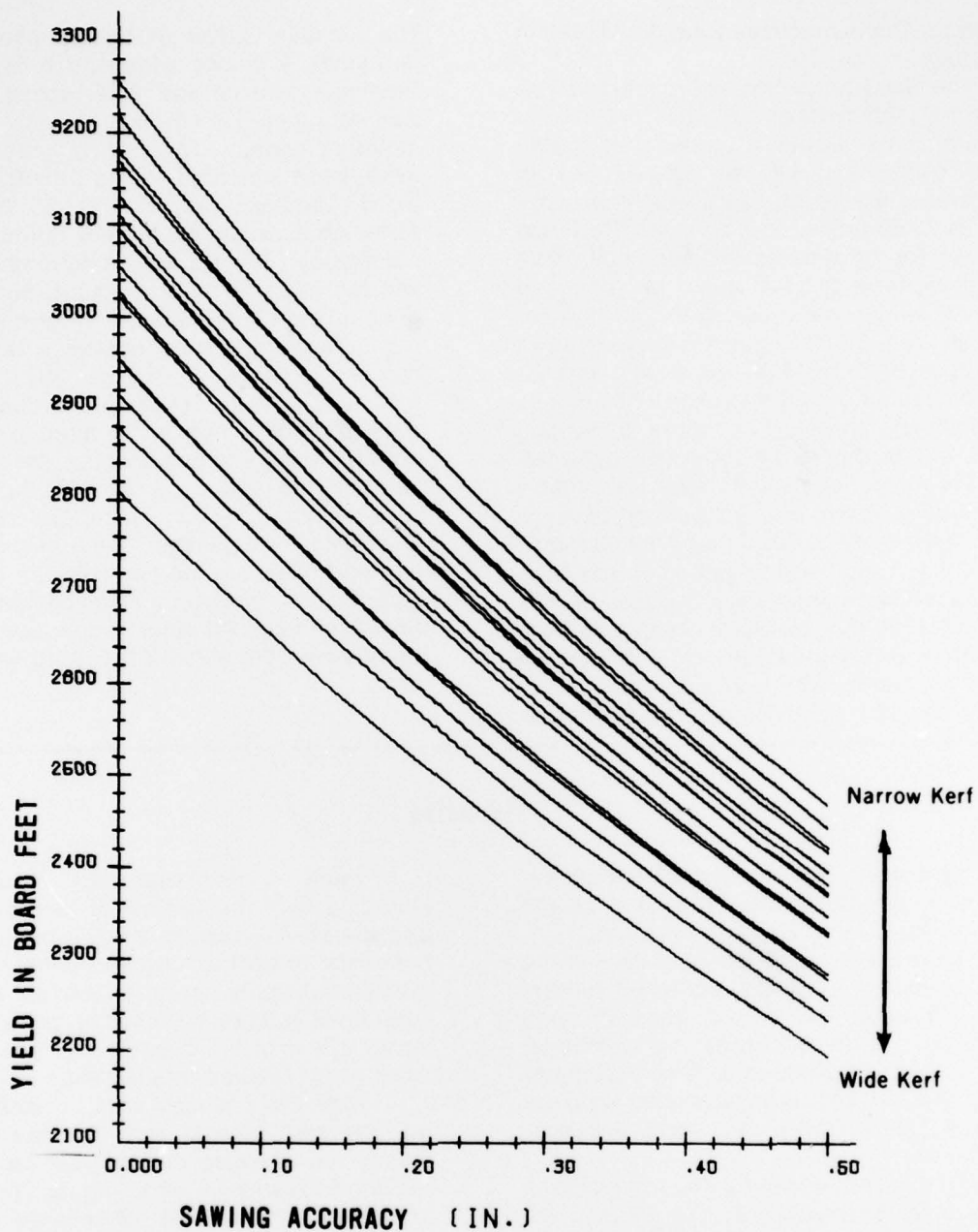

Figure 2.--Yield of a log sample showing effect of decreasing sawing accuracy in 16 combinations of vertical and horizontal kerf widths. The sample is composed of one log of each 1-inch diameter class.

(M 146 435)

inch-diameter, 16-foot-long log, using a 0.125 kerf in both the vertical and horizontal plane at sawing accuracy levels of 0.0, 0.2, 0.3, and 0.5 inch.

The large and small ends of the logs are

shown along with the dressed lumber. All lumber is full length (16 ft) unless marked with a different length. Lumber yield decreases from 167 board feet with perfect sawing accuracy to 127 board feet at a

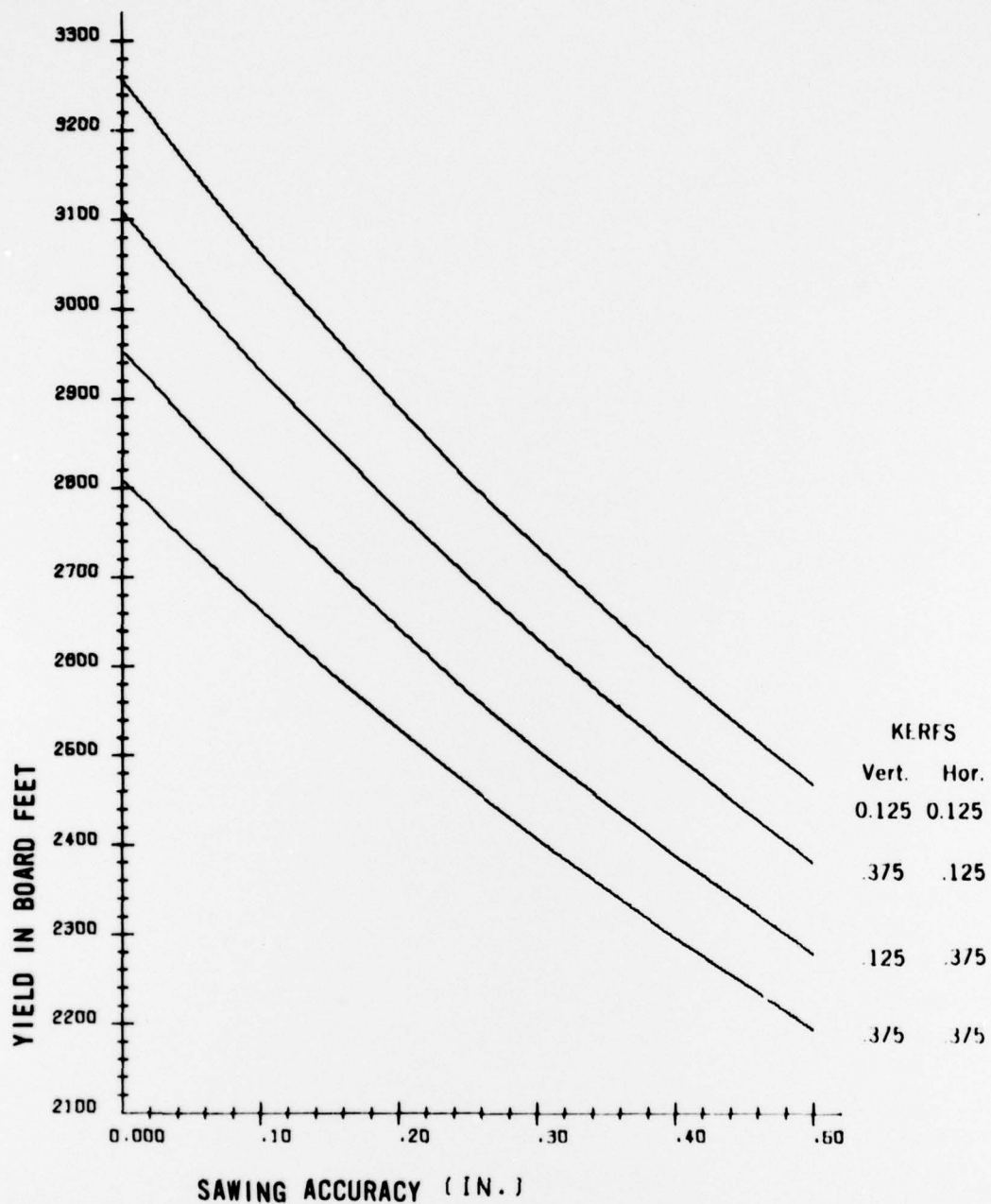

Figure 3.--The effect of sawing accuracy on yield for four representative vertical and horizontal kerf combinations. The sample is composed of one log of each 1-inch diameter class. (M 146 433)

sawing accuracy level of 0.5 inch.

The yield that a mill operator could expect at all levels of sawing accuracy from a unit of logs sufficient to produce 1,000 board feet when sawn with perfect sawing ac-

curacy is shown in figure 7. For example, if the mill has a headsaw kerf of 0.375, a cant saw kerf of 0.375, and sawing accuracy of 0.3 inch, it can expect to obtain 857 board feet from the same logs that would yield 1,000

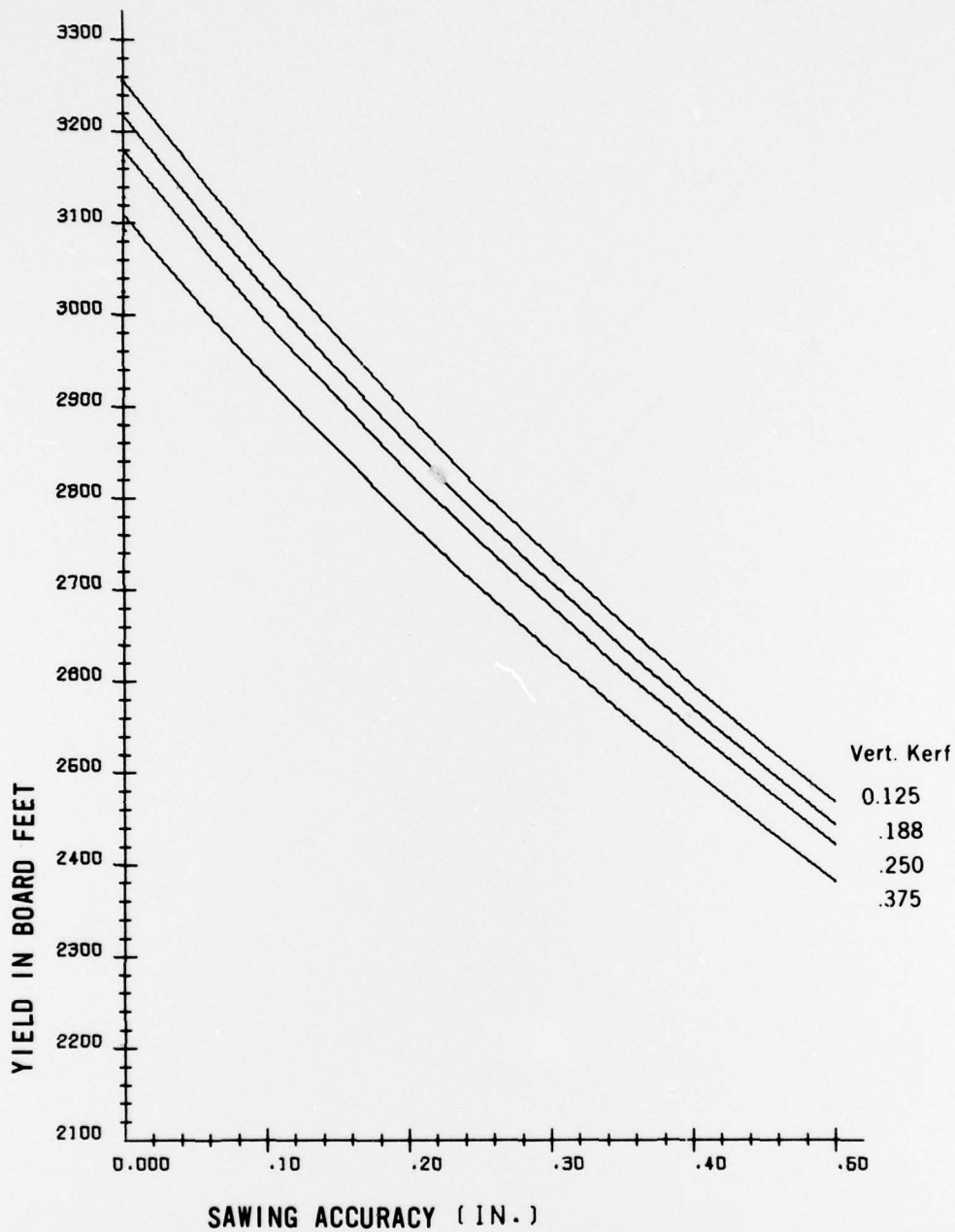

Figure 4.--The effect on yield of varying the vertical kerf with a constant horizontal kerf of 0.125 inch for all levels of sawing accuracy. The sample is composed of one log of each 1-inch diameter class. (M 146 434)

board feet if there were perfect sawing accuracy. With kerfs of 0.125 and 0.125, the expected yield would be 840 board feet. Of

course, the initial unit of logs from which 1,000 board feet lumber tally could be obtained is larger for the wider kerfs.

U.S. Forest Products Laboratory.

Improving sawing accuracy does help, by  
Abigail R. Stern, Hiram Hallock, and David W. Lewis,  
Madison, Wis., FPL, 1979.  
13 p. (Research Paper FPL 320).

The Best Opening Face computer program was used to  
map the relationship between sawing accuracy and yield.

KEYWORDS: Kerf, log breakdown, lumber yield, over-  
sizing, sawing accuracy, sawing variation.

U.S. Forest Products Laboratory.

Improving sawing accuracy does help, by  
Abigail R. Stern, Hiram Hallock, and David W. Lewis,  
Madison, Wis., FPL, 1979.  
13 p. (Research Paper FPL 320).

The Best Opening Face computer program was used to  
map the relationship between sawing accuracy and yield.

KEYWORDS: Kerf, log breakdown, lumber yield, over-  
sizing, sawing accuracy, sawing variation.

U.S. Forest Products Laboratory.

Improving sawing accuracy does help, by  
Abigail R. Stern, Hiram Hallock, and David W. Lewis,  
Madison, Wis., FPL, 1979.  
13 p. (Research Paper FPL 320).

The Best Opening Face computer program was used to  
map the relationship between sawing accuracy and yield.

KEYWORDS: Kerf, log breakdown, lumber yield, over-  
sizing, sawing accuracy, sawing variation.

U.S. Forest Products Laboratory.

Improving sawing accuracy does help, by  
Abigail R. Stern, Hiram Hallock, and David W. Lewis,  
Madison, Wis., FPL, 1979.  
13 p. (Research Paper FPL 320).

The Best Opening Face computer program was used to  
map the relationship between sawing accuracy and yield.

KEYWORDS: Kerf, log breakdown, lumber yield, over-  
sizing, sawing accuracy, sawing variation.

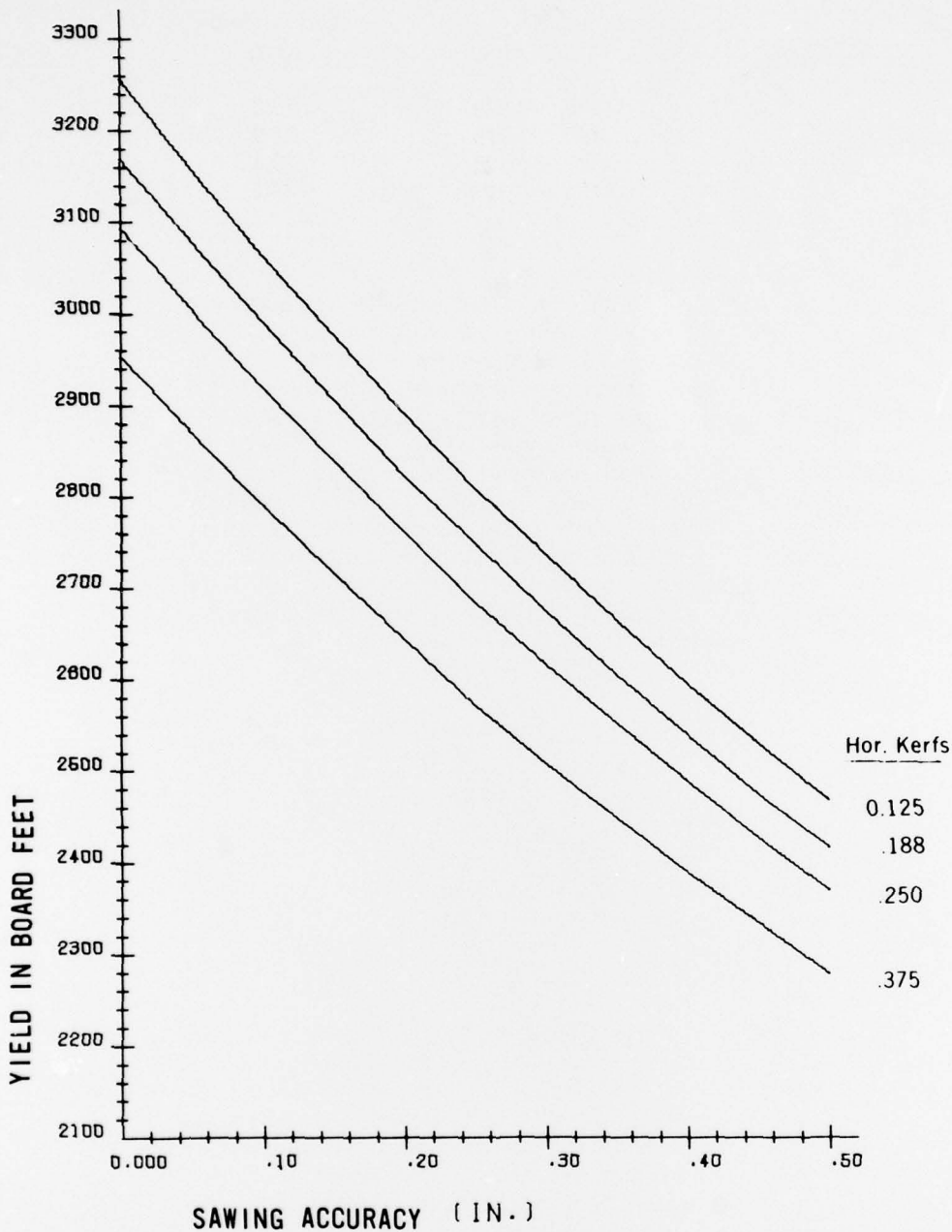

Figure 5.--The effect on yield of varying the horizontal kerf with a constant vertical kerf of 0.125 inch for all levels of sawing accuracy. The sample is composed of one log of each 1-inch diameter class. (M 146 436)

Also, graphically illustrated is the interaction between the various combinations of kerf widths and the rate of decrease in

yield as sawing accuracy declines. For example, as sawing accuracy declines from 0.0 to 0.5, yield decreases in terms of percent:

Kerf		Loss in Yield-- (Pct)
Vert.	Hor.	
0.375	0.375	21.8
.125	.375	22.9
.375	.125	23.4
.125	.125	24.2

Thus, decreases in sawing accuracy clearly are more detrimental to yield for narrower kerfs than for wider kerfs. This is particularly relevant because attainment of a high degree of sawing accuracy is more difficult with narrower kerfs.

Perhaps even more relevant, because few mills have sawing accuracy levels of either 0.0 or 0.5, is a look at what could be gained in terms of yield for each of these four kerf combination situations if it is presumed that sawing accuracy improves from 0.2 to 0.1 inch:

Kerf		Increased Yield-- (Pct)	Increased Yields Per MBF (Bd. Ft.)
Vert.	Hor.		
0.375	0.375	5.3	53
.125	.375	5.5	55
.375	.125	5.6	56
.125	.125	6.0	60

So far, all results relating sawing accuracy to lumber yield have been based on a flat distribution of logs whose diameters range from 4.8 to 20.5 inches. Figure 8 shows the same relation for two single log diameter classes, the 7-inch class and the 20-inch class. Both graphs show the minimum and maximum sawkerfs studied. Log diameter has little effect on the relation between sawing accuracy and lumber yield.

The curves in figure 8 accent the step-like nature of incremental changes in yield as sawing accuracy is changed. This variability in the slope of individual diameter curves is lost when all diameters are combined as in figure 7.

**SAWING ACCURACY - 0.0**

Yield - 167 bf.

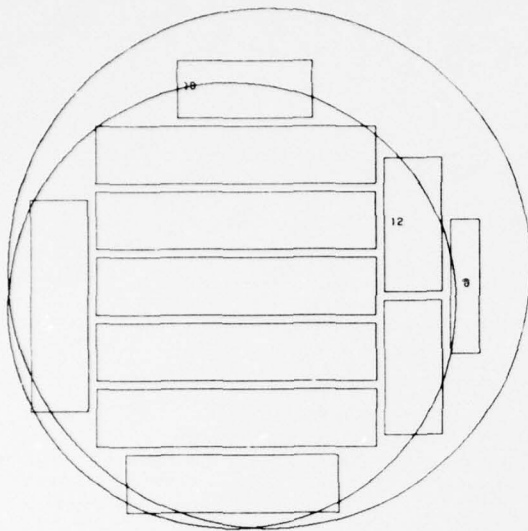

**SAWING ACCURACY - 0.2**

Yield - 145 bf.

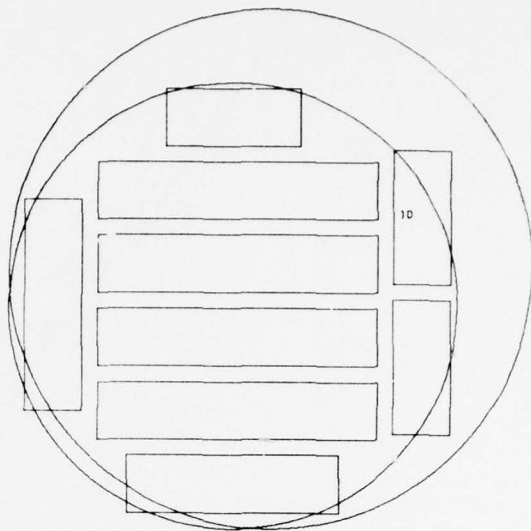

**SAWING ACCURACY - 0.3**

Yield - 140 bf.

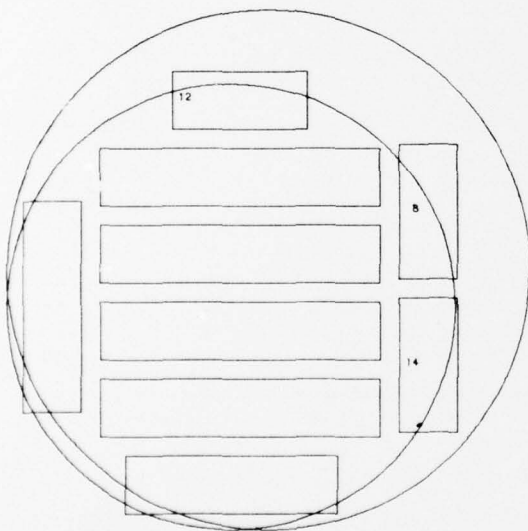

**SAWING ACCURACY - 0.5**

Yield - 127 bf.

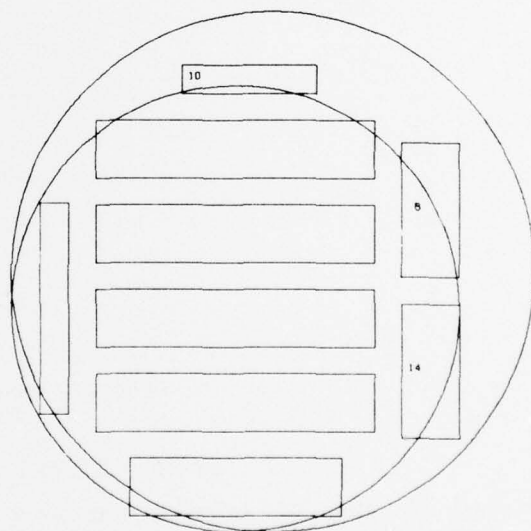

Figure 6.--Actual sawing solutions for a 12-inch-diameter, 16-foot-long log with 2 inches of taper at sawing accuracy levels of 0.0, 0.2, 0.3, and 0.5. Both vertical and horizontal kerfs are 0.125 inch. Numbers indicate lumber shorter than 16 feet in length.

(M 146 431)

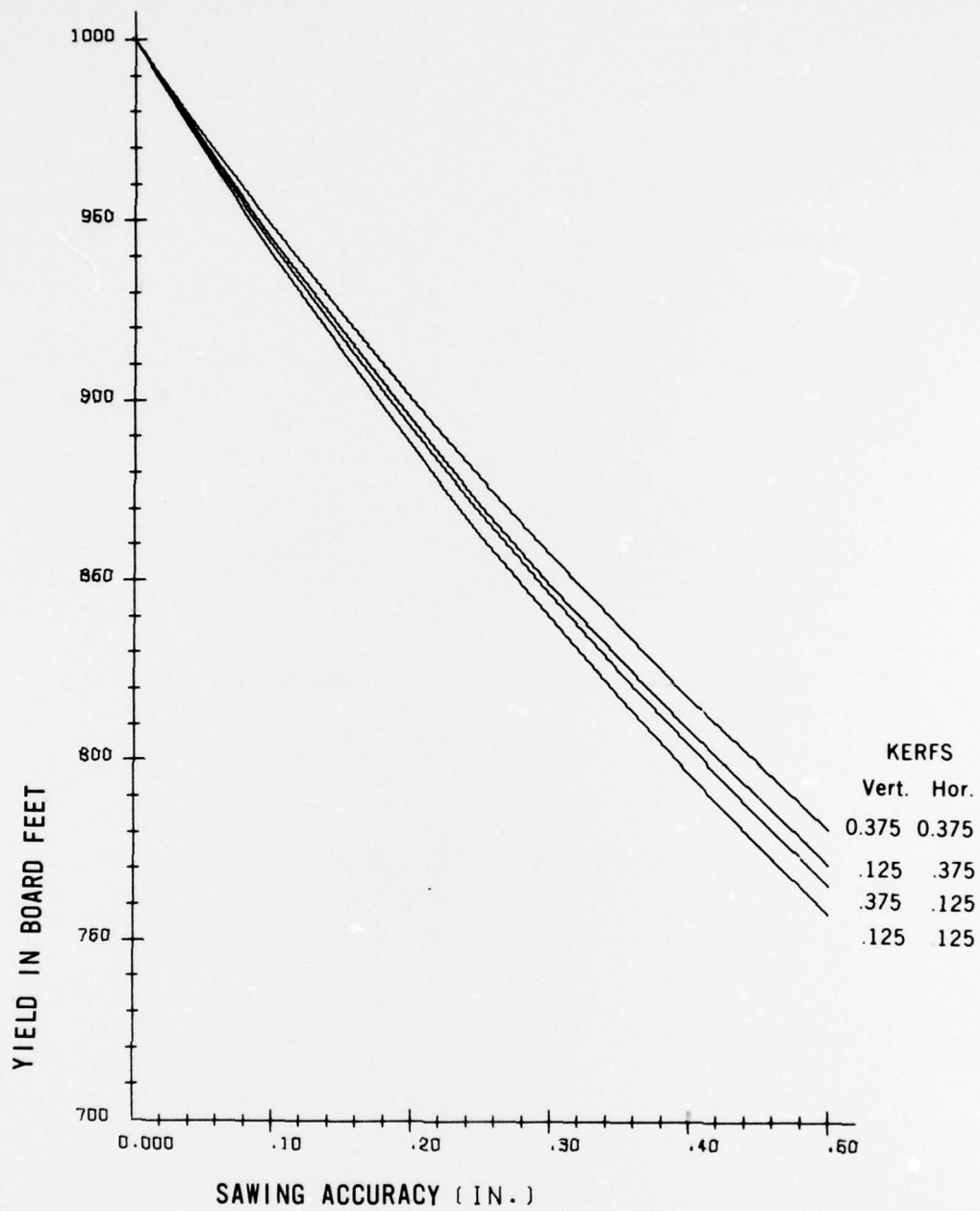

Figure 7.--The effect of sawing accuracy on yield expressed as loss in board feet from a unit of logs yielding 1,000 board feet at 0.0 sawing factors. Expected yields are shown for four kerf combinations. The sample is composed of one log of each 1-inch diameter class.

(M 146 430)

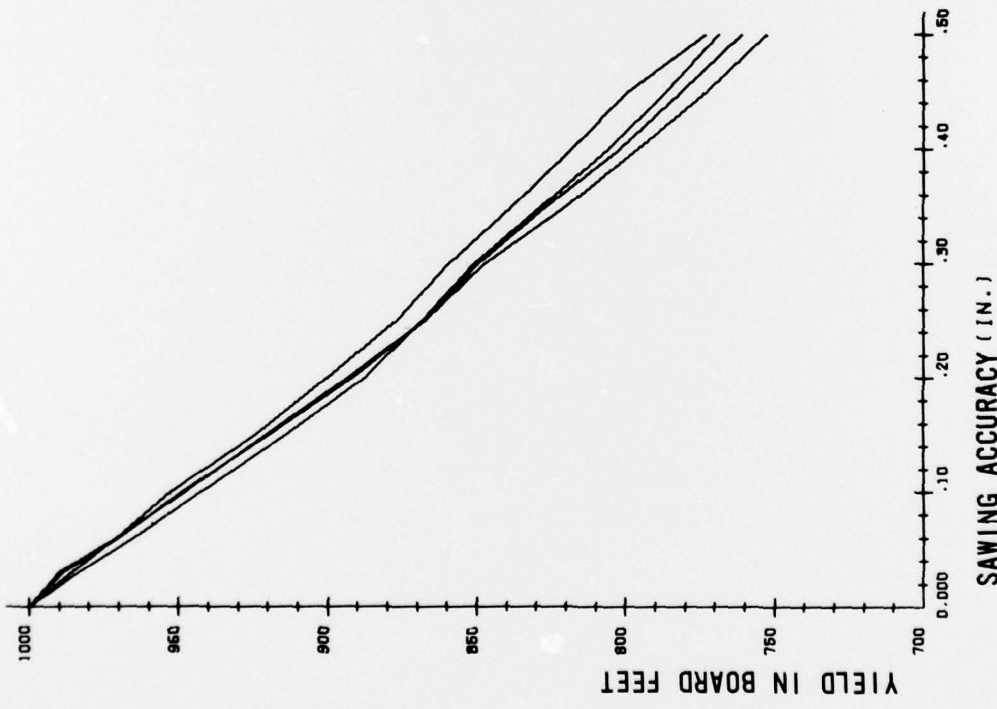
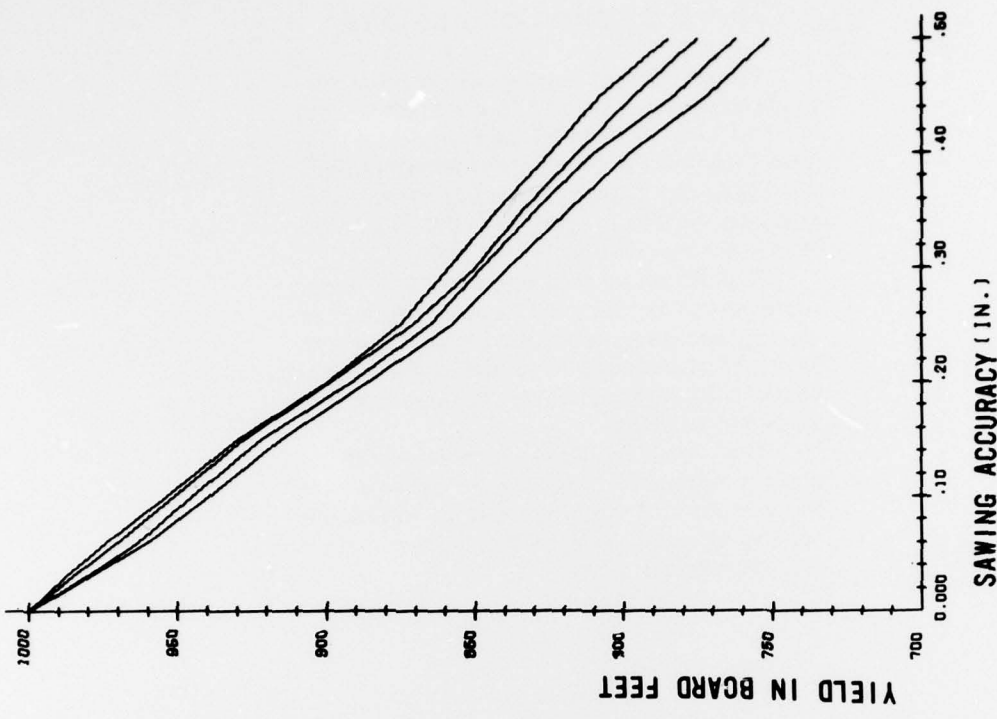

Figure 8.--The effect on yield of varying sawing accuracy for the 7-inch diameter class (left) and the 20-inch diameter class (right). Kerfs represent the narrowest, widest, and two intermediate widths.

(M 146 432)

## Summary and Conclusions

The relation of sawing accuracy to lumber recovery was studied for the cant sawing method and 16 sawkerf combinations. The Best Opening Face program mathematically simulated log breakdown using 11 levels of sawing accuracy ranging from 0.0 inch to 0.5 inch in the calculation of lumber yield.

Results show that exponentially larger increases in lumber yield can be expected as sawing accuracy improves for any sawkerf. The rate of increase in lumber yield for improving sawing accuracy is less as the sawkerf increases.

The relatively larger lumber yields as sawing accuracy is increased tend to offset the exponentially rising cost of improving sawing accuracy due to the higher cost of precision equipment.