

AD-A068 038

ARMY INDUSTRIAL BASE ENGINEERING ACTIVITY ROCK ISLAND IL F/G 5/1
MANUFACTURING METHODS AND TECHNOLOGY PROGRAM PROJECT STATUS REP--ETC(U)
APR 79 H E WEIDNER, L S HANCOCK

UNCLASSIFIED

NL

1 OF 2
ADA
068038



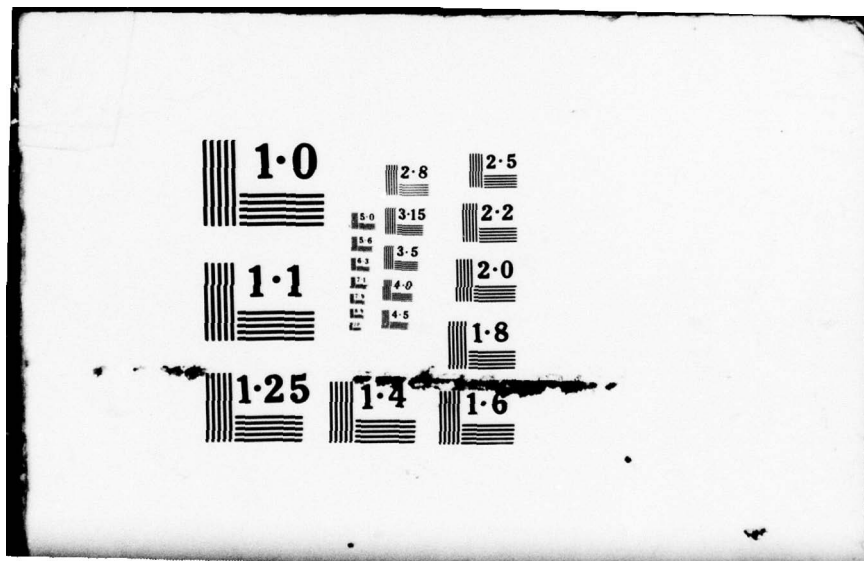

1.0

2.8

2.5

5.0

3.15

2.2

1.1

5.6

3.5

2.0

4.0

4.5

1.8

1.25

1.4

1.6

U.S. ARMY
MATERIEL DEVELOPMENT
AND READINESS COMMAND

12
B.S.

AD A068038



M **LEVEL**
M **MANUFACTURING**
M **METHODS &**
T **TECHNOLOGY**

DDC
RECEIVED
MAY 2 1979
C

DDC FILE COPY

SEMIANNUAL REPORT

SECOND CY 78

(RCS DRCMT-301)

DISTRIBUTION STATEMENT A
Approved for public release
Distribution Unlimited

PREPARED BY

79 04 30 022

APRIL 1979

USA INDUSTRIAL BASE ENGINEERING ACTIVITY

MANUFACTURING TECHNOLOGY DIVISION

ROCK ISLAND, ILLINOIS 61299

UNCLASSIFIED

SECURITY CLASSIFICATION OF THIS PAGE (When Data Entered)

REPORT DOCUMENTATION PAGE		READ INSTRUCTIONS BEFORE COMPLETING FORM
1. REPORT NUMBER SECOND CY78	2. GOVT ACCESSION NO.	3. RECIPIENT'S CATALOG NUMBER
4. TITLE (and Subtitle) MANUFACTURING METHODS & TECHNOLOGY SEMIANNUAL REPORT	AD60607	5. TYPE OF REPORT & PERIOD COVERED Semiannual Report 1 Jul 78 - 31 Dec 78
7. AUTHOR(s) H. E. Weidner L. S. Hancock	11 Apr 79	8. CONTRACT OR GRANT NUMBER(s) N/A
9. PERFORMING ORGANIZATION NAME AND ADDRESS US Army Industrial Base Engineering Activity ATTN: DRXIB-MT Rock Island, IL 61299		10. PROGRAM ELEMENT, PROJECT, TASK AREA & WORK UNIT NUMBERS N/A
11. CONTROLLING OFFICE NAME AND ADDRESS US Army Industrial Base Engineering Activity ATTN: DRXIB-MT Rock Island, IL 61299		12. REPORT DATE April 1978
14. MONITORING AGENCY NAME & ADDRESS (if different from Controlling Office) US Army Materiel Development & Readiness Command ATTN: DRCMT, Office of Manufacturing Technology 5001 Eisenhower Avenue Alexandria, VA 22333		13. NUMBER OF PAGES 174
		15. SECURITY CLASS. (of this report) UNCLASSIFIED
		15a. DECLASSIFICATION/DOWNGRADING SCHEDULE N/A
16. DISTRIBUTION STATEMENT (of this Report) DISTRIBUTION UNLIMITED		
DISTRIBUTION STATEMENT A Approved for public release; Distribution Unlimited		
17. DISTRIBUTION STATEMENT (of the abstract entered in Block 20, if different from Report) DISTRIBUTION UNLIMITED		
18. SUPPLEMENTARY NOTES N/A (6) Manufacturing Methods and Technology Program Project Status Report, Second Half		
19. KEY WORDS (Continue on reverse side if necessary and identify by block number) Manufacturing Methods & Technology MMT		
20. ABSTRACT (Continue on reverse side if necessary and identify by block number) This document is a summary compilation of the MANTECH/MMT Program Project Status Reports (RCS DRCMT-301) submitted to IBEA from DARCOM major subordinate commands and project managers. Each page of the computerized section lists project number, title, status, funding, and projected completion date. Summary pages give information relating to the overall DARCOM program.		

DD FORM 1473 1 JAN 73

EDITION OF 1 NOV 65 IS OBSOLETE

UNCLASSIFIED

SECURITY CLASSIFICATION OF THIS PAGE (When Data Entered)



DEPARTMENT OF THE ARMY
US ARMY INDUSTRIAL BASE ENGINEERING ACTIVITY
ROCK ISLAND, ILLINOIS 61299

02 APR 1979

DRXIB-MT

SUBJECT: Manufacturing Methods and Technology (MMT) Program Project
Status Report, Second Half CY78

SEE DISTRIBUTION

1. Reference is made to paragraph 3-8e(1) of AR 700-90, C1, Logistics, Army Industrial Preparedness Program, dated 10 March 1977.
2. This Semiannual Report is a summary compilation of the MMT Program Project Status Reports (RCS DRCMT-301) submitted to IBEA from DARCOM major subordinate commands (MSC) and project managers. The document is used as a management tool for monitoring the progress of MMT projects.
3. The format for this report has been altered to present a more complete view of the program. There are now separate sections in the report showing projects that are new, active, and completed.
4. Persons who are interested in the details of an individual project should contact the manufacturing technology representative at the MSC. A list of those representatives is included in Appendix III to this report. Project officers for this task were Ms. L. S. Hancock and Mr. H. E. Weidner, Autovon 793-6521.

A handwritten signature in cursive script, appearing to read "J. R. Gallaugh".

J. R. GALLAUGH
Director,
Industrial Base Engineering Activity

79 04 30 022

CONTENTS

<u>TABLE OF CONTENTS</u>	
<u>INTRODUCTION</u>	
<u>OVERALL PROGRAM STATUS</u>	
Program Statistics	1
Projects Added 2nd Half, CY78	1
Projects Completed 2nd Half, CY78	3
<u>SUMMARY PROJECT STATUS REPORTS</u>	
Test and Evaluation Command	5
Aviation Systems R&D Command	17
Armament R&D Command	35
Armament Materiel Readiness Command (Ammunition)	45
Armament R&D Command	47
Armament Materiel Readiness Command (Weapons)	55
Mobility Equipment R&D Command	65
Communications R&D Command	93
Electronics R&D Command	105
Army Material and Mechanics Research Center Material Development & Readiness Command	111
Natick R&D Command	115
Missile R&D Command	123
Missile Materiel Readiness Command	131
Tank-Automotive R&D Command	135
Tank-Automotive Materiel Readiness Command	147
<u>APPENDICES</u>	
I - Command Identification	153
II - User's Guide	155
III - Army MMT Program Representatives	159
<u>DISTRIBUTION</u>	163
	169

ACCESSION for	
NTM	Wire Section <input checked="" type="checkbox"/>
NSC	Buff Section <input type="checkbox"/>
UNANNOUNCED	<input type="checkbox"/>
JUSTIFICATION	<input type="checkbox"/>
BY	
DISTRIBUTION/AVAILABILITY CODES	
Dist.	ALL <input type="checkbox"/> SP <input type="checkbox"/> CIAL <input type="checkbox"/>
A	

INTRODUCTION

BACKGROUND

The Army Manufacturing Methods and Technology (MMT) Program was established in 1964 as a part of the Army Production Base Support (PBS) Program. The MMT Program has goals of improving existing manufacturing technology, translating new technology into production line processes, and supporting the modernization and expansion of the military hardware production base. Army Regulation AR 700-90, C1, paragraph 3-6, describes the objectives of the MMT Program as follows:

To develop, on a timely basis, manufacturing processes, techniques, and equipment for use in production of Army materiel. In achieving this objective, strong consideration will be given to efforts that insure producibility, reduce costs or lead times, relieve critical materiel/materials shortages, enhance safety, provide for abatement of pollutants, improve product quality and reliability, and advance the state-of-the-art in manufacturing methods and equipment.

AUTHORIZATION

This MMT Semiannual Report provides the status summaries of 571 active projects with an authorized cost of \$269,286,800. The report is compiled, edited, and published for HQ, DARCOM by the Manufacturing Technology Division of the Army Industrial Base Engineering Activity (IBEA) according to AR 700-90, C1, paragraph 3-8e(1).

Distribution of this report is extended to Army materiel developers and users and to counterparts in the Navy and the Air Force. Inquiries on the detailed technical aspects of any individual project may be answered by the MMT Program representative of the action command under which the project was completed or is being executed. Inquiries or suggestions may also be directed to the Manufacturing Technology Division of IBEA.

COMPOSITION OF THE REPORT

The report is composed of two major sections:

Overall Program Status. A summary of important information that relates to the overall DARCOM program. The section includes statistics on the number of projects which were added and completed, changes in funding and data on allocations and expenditures of funds.

Summary Project Status Report. These reports are divided by organization and include a summary of funding by fiscal year and a narrative status for each project.

MMT PROGRAM
OVERALL PROGRAM STATUS



PROGRAM STATISTICS

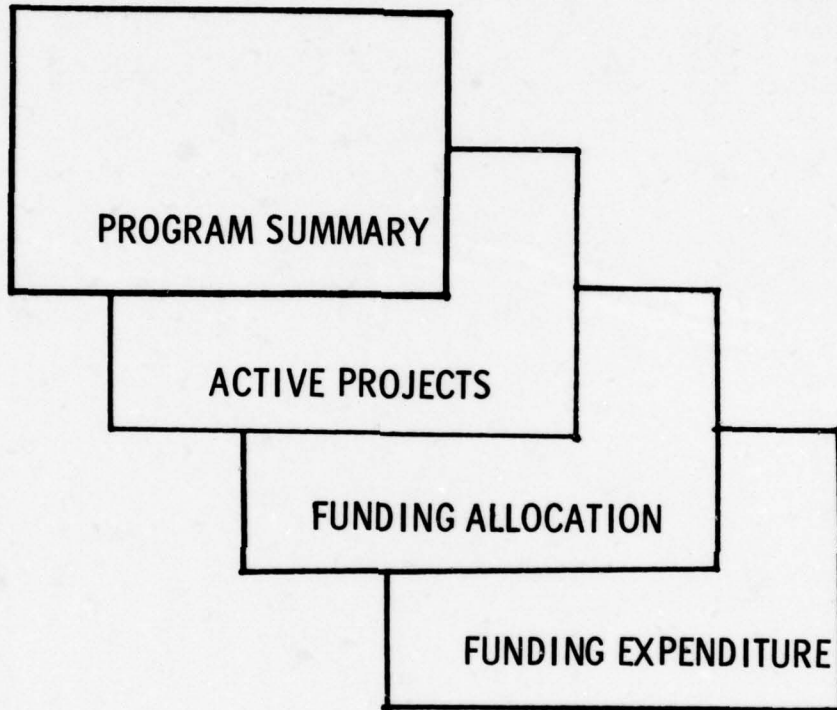

PROGRAM STATISTICS

The overall MMT project reporting and funding status for the second half of CY78 is presented on the next eight pages. These tabulations include data for the DARCOM Major Subordinate Commands that have active projects and the AMMRC & DARCOM sponsored projects. The summaries provide cumulative figures relative to the number of projects by fiscal years, and distribution and expenditures of funds on contract and in-house. The projects that were completed during this report period are not included in these summaries as in the past. They are listed in a separate section.

Additional efforts were expended during this report period to reduce the number of delinquent status reports. In November a call letter was mailed to each SUBMACOM. Inclosed with this letter was a computerized listing of the projects for which a semiannual report was required for this report period. There were 18 delinquent reports for this period. There will be a continuing effort to reduce the number of delinquent reports.

MM&T PROGRAM SUMMARY

Organization	Number of Projects			Funding Status		
	Previous Period	This Period	Percent Change	Previous Period	This Period	Percent Change
TECOM	4	3	-25	2,489,000	2,479,000	-1
AVRADCOM	54	77	+43	18,630,600	24,844,700	+33
ARRADCOM/ARRCOM (Ammo)	183	211	+15	125,159,000	134,679,800	+7
ARRADCOM/ARRCOM (Weapons)	62	81	+31	9,566,200	13,020,200	+36
MERADCOM	14	22	+57	3,043,000	5,424,000	+78
CORADCOM	8	12	+50	3,877,100	5,782,100	+49
ERADCOM	39	43	+10	19,356,300	22,592,000	+17
AMTRC/DARCOM	12	12	0	18,962,000	23,152,000	+22
NARADCOM	4	4	0	853,100	853,100	0
MIRADCOM/MIRCOM	57	67	+18	24,259,900	24,417,900	+1
TARADCOM/TARCOM	23	39	+70	4,786,000	12,042,000	+152
TOTAL	460	571	+24	230,982,200	269,286,800	+17

The MM&T Program Summary indicates that the number of active projects have (or will) increase by about 24%. The increase is caused primarily by the addition of the FY79 Projects that were added to the program and to a lesser extent by late start FY78 projects. Numerically, the largest increases were in Ammunition, Aviation, and Tank & Automotive respectively. The largest increase percentwise both in number and dollars was the Tank-Automotive program. The values for the previous report period have been revised to reflect the current reporting method.

ACTIVE PROJECTS
BY
FISCAL YEAR

Organization	70	71	72	73	74	75	76	77	78	79	TOTAL
TECOM								1	1	1	3
AVRADCOM		1		1	3	8	8	13	19	24	77
ARRADCOM/ARRCOM (Ammo)	1			1	7	10	35	44	55	47	211
ARRADCOM/ARRCOM (Weapons)				1	1	5	2	27	23	22	81
MERADCOM							1	2	8	11	22
CORADCOM			1				5	1	2	3	12
ERADCOM						3	12	16	6	6	43
AMMRC/DARCOM					1	1	1	2	3	2	12
NARADCOM					1		2	1			4
MIRADCOM/MIRCOM							3	11	31	21	67
TARADCOM/TARCOM							2	5	12	19	39
TOTAL	1	1	1	3	13	27	71	123	160	156	571

The median fiscal year for the active projects is now between FY77 and FY78. The total span of the projects still goes back to 1970 and the shift in median was primarily due to the influx of FY79 projects. A stated goal from the previous report period was to close out all FY70, 71, and 72 projects. These efforts were unsuccessful. Command project officers had been contacted for these projects and final Semiannual Reports were expected however, this did not occur. The median fiscal year for projects that were closed out was FY75 - FY76 and the range was from FY73 to FY79.

**PROGRAM FUNDING ALLOCATIONS
(MILLIONS)**

Organizations	No. Projects	Authorized Funds	Contractor Allocated	In-House Allocated
TECOM	3	\$ 2.5	\$ 0.1 (2%)	\$ 2.4 (98%)
AVRADCOM	77	24.8	15.7 (64%)	9.2 (36%)
ARRADCOM/ARRCOM (Ammo)	211	134.7	57.8 (43%)	76.9 (57%)
ARRADCOM/ARRCOM (Weapons)	81	13.0	4.3 (33%)	8.7 (67%)
MERADCOM	22	5.4	2.7 (51%)	2.7 (49%)
CORADCOM	12	5.8	3.2 (55%)	2.6 (45%)
ERADCOM	43	22.6	16.9 (75%)	5.7 (25%)
AMMRC/DARCOM	12	23.2	2.3 (10%)	20.9 (90%)
NARADCOM	4	0.9	0.6 (76%)	0.2 (24%)
MIRADCOM/MIRCOM	67	24.4	11.9 (49%)	12.6 (51%)
TARADCOM/TARCOM	39	12.0	3.3 (27%)	8.8 (73%)
TOTAL	571	\$269.3	\$118.8 (44%)	\$150.7 (56%)

The purpose of this chart is to indicate the distribution of project funds between contractors and in-house. The present status of the program has slightly more funding in-house than on contract (56% vs 44%) for the active program. A comparison to similar data from the previous two report periods does not establish a clear trend however, there does appear to be a shift towards increasing in-house funding (48%, 52% & 56% respectively). The actual values shown here will be slightly higher than the eventual state due to the inability of the commands to immediately put newly received funds out on contract. However, the trends should remain valid since at least alternate semiannual periods are in similar phases of the funding cycle.

**PROGRAM FUNDING EXPENDITURES
(MILLIONS)**

Organization	Projects	Authorized Funding	Contractor Allocated	Contractor Expended	In-House Allocated	In-House Expended
TECOM	3	\$ 2.5	\$ 0.1	\$ 0.0 (34%)	\$ 2.4	\$ 0.9 (37%)
AVRADCOM	77	24.8	15.7	5.4 (34%)	9.2	2.4 (26%)
ARRADCOM/ARRCOM (Ammo)	211	137.7	57.8	36.1 (62%)	76.9	30.2 (39%)
ARRADCOM/ARRCOM (Weapons)	81	13.0	4.3	1.4 (32%)	8.7	3.0 (34%)
MERADCOM	22	5.4	2.7	0.8 (30%)	2.7	0.4 (14%)
CORADCOM	12	5.8	3.2	2.0 (63%)	2.6	0.4 (15%)
ERADCOM	43	22.6	16.9	9.7 (57%)	5.7	1.4 (23%)
AMMRC/DARCOM	12	23.2	2.3	3.6 (156%)	20.9	11.2 (53%)
NARADCOM	4	0.9	0.6	0.5 (74%)	0.2	0.2 (92%)
MIRADCOM/MIRCOM	67	24.4	11.9	4.3 (36%)	12.6	2.4 (19%)
TARADCOM/TAF	39	12.0	3.3	0.7 (23%)	8.8	0.8 (9%)
TOTAL	571	\$269.3	\$118.8	\$ 64.5 (54%)	\$150.7	\$ 53.3 (35%)

The purpose of this chart is to indicate at what rate the project funds are being expended. The expenditure rate shown is lower than for the similar report period last year due primarily to the change in report format that dropped completed projects and added all newly funded projects. This method is more accurate for determining the actual status of funding at a given point in time. It is expected that the expenditure rates will be cyclic with the values being lower during the first half of the fiscal years.

PROJECTS ADDED IN SECOND HALF, CY78

TECOM

- 0 79 5071 TECOM TEST METHODOLOGY ENGINEERING MEASURES
Artillery, vehicle and electronic conventional test capabilities need to be upgraded to provide more timely accurate test data for the test and evaluation process.

AVRADCOM

- 1 78 7348 LTWT COMPOSITE FASTENING SYS FOR COMPOSITE HELICOPTER COMPTS
Present metal fasteners are excessive in cost, weight and are subpar in performance.
- 1 79 7036 ISOTHERMAL ROLL-FORGING COMPRESSOR BLADES
Technology for fabricating advanced engine materials into compressor blade configurations is either unavailable or excessive in cost.
- 1 79 7086 ABRADABLE SEALS FOR COMPRESSOR BLADE TIP APPLICATION
Extra blade tip clearance is allowed in helicopter engines to prevent tip rubbing and this degrades performance.
- 1 79 7113 COMPOSITE FUSELAGE MANUFACTURING TECHNOLOGY
Conventional metallic fuselage structures are excessive in weight and composite fuselage structures are expensive to fabricate.
- 1 79 7119 NDE TECHNIQUES FOR COMPOSITE STRUCTURES
Implementation of composite structures in the army aircraft is dependant upon the ability to detect and evaluate defects.
- 1 79 1783 SEMI-AUTO COMPOSITE MFR SYS FOR HELICOPTER STRUCTURES
Helicopter fuselage structures have high manufacturing costs due to high part count and high assembly costs. Methods of composite fabrication have been investigated but hand operations result in high labor costs.
- 1 79 7197 FABRICATION OF INTEGRAL ROTORS BY JOINING
Current gas turbine rotors are either integrally cast or the blades and disks are separate units. The blisk concept does not permit optimum mechanical properties of the unit and the other method requires complex and expensive machining.
- 1 79 7199 SURFACE HARDENING OF GEARS, BEARINGS AND SEALS BY LASERS
Case carburizing is expensive, requiring much energy, quenching dies, and final grinding.

PROJECTS ADDED IN SECOND HALF, CY78 (Continued)

- 1 79 7200 COMPOSITE ENGINE INLET PARTICLE SEPARATOR
The inlet particle separator structure is costly and heavy.
- 1 79 7202 APPLICATION OF THERMOPLASTICS
Full-scale flightworthy secondary structures composed of epoxy composite and metallic counterpart components are quite expensive.
- 1 79 7238 PRECISION FORGED ALUMINUM POWDER MTL HELICOPTER COMP
Many helicopter components are made from aluminum alloy forgings. These generally require a large no. of manufacturing operations and low mechanical properties.
- 1 79 7240 MACHINING METH FOR ESR 4340 STEEL FOR HELICOPTER APPL
Many critical helicopter parts have to contain high ballistic tolerance characteristics. To obtain this protection, these components are being fab'd from esr 4340 steel. However, the machining of this new material is not cost effective.
- 1 79 7241 HOT ISOSTATIC PRESSED TITANIUM CASTINGS
The current method of manufacturing rotor hubs results in excessive use of materials and machining.
- 1 79 7243 MACHINING OPERATIONS ON KEVLAR LAMINATED CONSTRUCTIONS
Present tooling and methods tend to cause delamination and excessive fuzzing/fraying of kevlar laminates.
- 1 79 7284 SUPERPLASTIC FORMING/DIFFUSION BONDING OF TITANIUM
Current engine compartment structures employ either steel or titanium to meet the high temperature requirements. As sheet metal structural components, these alloys are expensive to fabricate and assemble.
- 1 79 7285 CAST TITANIUM COMPRESSOR IMPELLER
Large amounts of material wastage and extensive machining times are required when titanium impellers are machined from oversized forgings.
- 1 79 7286 HIGH QUALITY SUPERALLOY POWDER PRODUCTION FOR TURBINE COMP
Vendors have experienced difficulty in cleanliness of superalloy powders.
- 1 79 7287 PRODUCTION METHODS FOR MULTI-ELEMENT MODULES FOR ARRAY ANTEN
Current phase shifting modules are assembled using discrete components in the driver circuits which requires numerous manual operations during fabrication.
- 1 79 7288 OPTIMAL CURING COND. FOR PROCESS FIBER-REINFORCED COMPOSITES
Current methods of curing composites are based on empirical determination of required processing conditions. A trial and error procedure is followed until the manufacturer is reasonably satisfied with mechanical properties.

PROJECTS ADDED IN SECOND HALF, CY78 (Continued)

- 1 79 7291 TITANIUM POWDER METAL COMPRESSOR IMPELLER
When complex configurations, such as centrifugal impellers and compressor rotors are utilized in gas turbine engines, typically high manufacturing costs are encountered.
- 1 79 7292 IMPROVED PROD PROC TO REDUCE COST OF TESTING MICROPROCESSOR
Testing of CPU cards intermittent microprocessor part failures are most difficult problems to solve. STD automatic test eqpt becomes inefficient, or unpregnable, when complex integrated circuits are portions of the printed circuit card tested.
- 1 79 7297 PROD-INSTALL OF URETHANE EDGE GUARDS ON ROTOR BLADES
The current AH-1Q composite improved main rotor blade utilizes a thermoplastic polyurethane leading edge erosion guard. While this design offers significant advantages in performance and cost, significant improvement can be made in mfg process.
- 1 79 7315 LOW COST MANUFACTURE OF POISE GIMBAL
The present approach to fabrication of the several gimbals and base plate is casting and machining magnesium. Magnesium gimbals are expensive and have a rather low stiffness.
- 1 79 7338 COMPOSITE TAIL SECTION
Manufacture of helicopter structures do not take into account potential advantages resulting from composites. Cost, weight savings, and ballistic advantages result from the use of composites.
- 1 79 7340 COMPOSITE MAIN ROTOR BLADE
Current production composite blade programs have not been oriented toward optimizing manufacturing techniques/processes related to blade configurations, fabrication methods, and improved structural reliability.

ARRADCOM-ARRCOM (AMMO)

- 5 78 1353 SMOKE MIX PROCESS (GLATT)
Air Polluting, labor intensive, and dust laden atmosphere.
- 5 78 4143 MFG OF CANISTERS AND COMP F/M259 & M264 ROCKETS
The current burning characteristics of white phosphorous -WP- are marginal and could be improved.
- 5 78 4163 CONTROLLED PRODUCTION LOADING F/105 MM HEAT M456
Through X-ray analysis and sectioning of the projectile both from current production and inventory, a significant amount of critical cast defects were observed in the explosive cast.

PROJECTS ADDED IN SECOND HALF, CY78 (Continued)

- 5 78 4289 STUDIES OF HAZARD CLASSIFICATION OF EXPLOSIVES AND PRPLLNT
Testing in-process materials for the numerous process operations used in the various stages can be time consuming and costly.
- 5 78 4310 DMSO RECRYSTALLIZATION OF HMX/RDX
Current solvents used for recrystallizing RDX and HMX have marginal solvating power and are limited in the quantities of RDX and HMX they can recrystallize.
- 5 78 4322 CHARACTERIZE DORMANCY EFFECT ON ELECTRONIC EQUIPMENT
To provide quick mobilization response of electronic systems.
- 5 78 4343 IMPROVED NITROCELLULOSE PROCESS CONTROL
The new continuous nitrocellulose nitration facilities and the more automated propellant lines will impose tighter tolerance requirements on control parameters of NC manufacture.
- 5 78 4462 MODERNIZED FAD FOR MULTI-BASE PROP
Forced air drying process and facilities must be modified to reduce the pollution emissions and at the same time recover valuable propellant material.
- 5 79 1295 MODERNIZATION OF CHARCOAL FILTER TEST EQUIPMENT
Charcoal filter testing equipment needed to provide testing capability for various chemical agents does not exist.
- 5 79 1296 MT FOR CB FILTERS
Existing filter production facilities are obsolete, inefficient and expensive to operate.
- 5 79 1335 MAN TECH FOR NEW PROTECTIVE MASK
Fabrication of one-piece plastic masks with adequate optical characteristics is difficult. Vision reduction and distortion are critical.
- 5 79 1345 BIOLOGICAL WARNING SYSTEM
There is no biological agent detector mass production capability.
- 5 79 1347 ADVANCED TECH FOR MANUFACTURE OF RED PHOSPHORUS
No capability exists in US to manufacture RP.
- 5 79 1354 SLUDGE VOLUME REDUCTION AND DISPOSAL PROCESS STUDY
Sludge buildup needs to be disposed.
- 5 79 1355 MANUFACTURING PLANT TOXIC EFFLUENT/EMMSION PRETREATMENT
Toxic substances in effluent need pretreatment. Direct support of MCA protect.
- 5 79 3913 MECHANICAL JOINING OF MINIATURIZED ELECTRONIC COMPONENTS
Electronic fuze circuits require high heat to fabricate components and join component leads. A high spoilage rate and a limitation on usable materials are the result of this limitation.

PROJECTS ADDED IN SECOND HALF, CY78 (Continued)

- 5 79 3960 PROTOTYPE PDN EQUIP FOR PRINTED CIRCUIT BOARDS
PCB's undergo problems with flow solderability, line width, and in-process handling when transferred to large-sheet, multiple-array commercial production.
- 5 79 3961 IMPROVED 3-D VIBRATION ACCEPTANCE TEST FOR ART FUZES
Current testing of S and A mechanisms is costly and time consuming and does not expose the item to true service environments.
- 5 79 4000 AUTOMATED M55 DETONATOR PDN EQUIPMENT
Current production facilities lack versatility, present quality problems and are costly to operate and maintain.
- 5 79 4007 EVALUATION - ACETIC ANHYDRIDE RECYCLE
In the acetic anhydride mfg process at Holston AAP a major source of air and water pollution is the barometric condensers and steam ejectors in the "E" scrubber effluent line. The process also uses large quantities of steam and cooling water.
- 5 79 4024 DSN DEV BLD PROT COMP AND AUTO ASSY MACH M223 FZ
Concepts for automating M223 fuze assembly have not been evaluated or tried.
- 5 79 4046 QUANTITATIVE ANAL. OF BLENDED EXPLOS. SAMPLES
Quantitative analysis of blended explosive samples requires four hours.
- 5 79 4051 IMPROVED INSTR CONTROL FOR ACID PLANTS
Instrumentation/control systems provided by A/E contractors do not operate properly, are difficult to maintain/repair, and do not provide the necessary information for safe operation of the units.
- 5 79 4062 AUTO MFG SYSTEM FOR MORTAR INCREMENT CONTAINERS
Present manufacturing capabilities are inadequate to meet the mobilization requirement alternate II volume.
- 5 79 4064 AUTO LAP OPERATIONS FOR 105MM TANK CARTRIDGES
The existing and largely manual LAP lines have a low level of product quality and control. There are variable and uncertain production lead times due to the high product.
- 5 79 4084 OPACITY/MASS EMISSION CORRELATION
Smoke emission monitoring required by EPA, equipment and instruments are costly and not tested or optimized.
- 5 79 4124 FABRICATION OF CONTROL ACTUATION SYSTEM HOUSINGS
The housings used in tactical weapons control systems are expensive. The loading requires the use of aluminum housings made from high cost single purpose equipment or low cost general which results in high cycle time cost.

PROJECTS ADDED IN SECOND HALF, CY78 (Continued)

- 5 79 4133 AUTO INSPECTION FOR CRITICAL DEFECTS IN THE M55 DETONATOR
100% inspection of three critical visual defects are currently performed manually. Two of these inspections require handling extra sensitive detonators and has resulted in numerous injuries.
- 5 79 4214 POLLUTION ENGINEERING FOR 1983-85 REQUIREMENTS
The federal regulations for environmental control are changing and becoming more stringent for 1983 and 1985.
- 5 79 4281 CONSERVATION OF ENERGY AT ARMY AMMUNITION PLANTS
Reduce energy consumption at ammunition plants.
- 5 79 4285 TNT EQUIVALENCY TESTING FOR SAFETY ENGINEERING
Present criteria for blast resistant structures is in terms of surface burst of hemispherical TNT. In structural design, to protect from the output of other energetics, the designers must have data pertinent to the material in question.
- 5 79 4288 EXPLOSIVE SAFE SEPARATION AND SENSITIVITY CRITERIA
Information is required to upgrade processes and facilities to provide max safety by the development on safe sep distances between explosive and end item to determine safe depth of explosives and to determine sensitivity criteria.
- 5 79 4291 BLAST EFFECTS IN THE MUNITIONS PLANT ENVIRONMENT
Most of the design effort is in the area of lace reinforced structures for closed in areas to an explosion. We must attempt to utilize com construction material.
- 5 79 4310 DMSO RECRYSTALLIZATION OF HMX/RDX
Current solvents used for recrystallizing RDX and HMX have marginal solvating power and are limited in the quantities of RDX and HMX they can recrystallize.
- 5 79 4312 INJECTION MOLDING FOR PRODUCTION EXPLOSIVE LOADING
Melt loading of small explosive items normally requires large surpluses of molten explosive to obtain good filling char. Surplus riser material can be twice the amount loaded into end items. Very small items cannot be effectively melt loaded at all.
- 5 79 4444 MMT-BODY FOR M42/M46 GRENADES
Present methods for production M42 and M46 grenades are costly.
- 5 79 4454 AUTO INSPECTION DEVICE OF EXPLOSIVE CHARGE IN SHELL
Currently conventional film radiography characterized by high cost of film and high personnel costs is used for detection of defects in explosive casts. This is not only costly but involves the questionable reliability of human interpretation.

PROJECTS ADDED IN SECOND HALF, CY78 (Continued)

- 5 79 4460 CONT MIXER-ILLUMINANT COMP ANAL & CONTROL SYSTEM
Currently, the reproducibility of the illuminant composition mix in this process is entirely dependent upon the respective automatic feeders to meter out the proper mix.
- 5 79 4462 MODERNIZED FAD FOR MULTI-BASE PROPELLANTS
Forced air drying process and facilities must be modified to reduce the pollution emissions and at the same time recover valuable propellant material.
- 5 79 4466 EVAL TNT, CYCLOTOL, OCTOL IN MELT-POUR FACILITY
The melt/pour explosive fill equipment was designed for the Army's preferred fill, Comp B with little regard for the application of this equipment to the alternate explosive fills.
- 5 79 4469 AUTO INSERTION OF GRENADE LAYERS
The manual insertion grenade layers into projectiles is a highly manual, costly and hazardous operation.
- 5 79 4472 DEV OF EQUIP/PROC F/AUTO/MECH FAB OF CTR CORE PROP BAGS
Manufacturing of center core prop bags is a long, time consuming, piecemeal process which is very costly.
- 5 79 4474 DEHUMIDIFIED AIR FOR DRYING SINGLE-BASE PROPELLANT
Humid air requires more energy to dry single base propellant.
- 5 79 4481 PYROLYSIS OF ARMY AMMUNITION PLANT SOLID WASTE
Waste is destroyed without recovery of energy.
- 5 79 4493 DESIGN PARAMETERS FOR LARGE-SCALE PROCESS VESSELS
Information is required to develop hoppers for energetic material so that if fire occurs detonations can be prevented.
- 5 79 4498 DEV METH FOR CONSOL & AUTO ASSY OF SMALL MINES
Off-line operations and multiple handling is required for the predominately manual LAP operations.
- 5 79 4508 PROCESS IMPROVEMENT OF PRESSABLE RDX COMPOSITIONS
Present production methods for pressable RDX compositions necessitates the use of facilities which will be required for comp B mfg during mobilization.
- 5 79 6634 MFG PROC FOR DU ALLOYS-LARGE CALIBER ARMOR DEFEATING PROJ
Depleted uranium is pyrophoric and requires care in machining and/or grinding to finish configuration.
- 5 79 6682 SIMULATION OF AMMUNITION PRODUCTION LINES
Methods are needed for designing production lines operating in a real environment and subject to the uncertainties associated with machine breakdowns and scheduled maintenance.

PROJECTS ADDED IN SECOND HALF, CY78 (Continued)

- 5 79 6693 BALL PROPELLANT DETERRENT COATING-CAM RELATED
The deterrent coating step in ball propellant manufacture produces a product that demonstrates significant ballistic variability from batch to batch.
- 5 79 6716 DEV OF COMP-AIDED MODELING OF FORMING OPN F/ARTY MPTS DSGN
Trial and error methods and the absence of proven automated design techniques for tooling cause unexpected failures in forming operations and delays in startup of ammunition production lines.
- 5 79 6736 TECH READINESS ACCEL THRU COMPUTER INTEGRATED MFG-TRACIM
Lead time to bring munition production lines to mobilization levels is excessive, non-availability of technical skills (tool makers and machinists) and up-to-date on item description, manufacturing process, tool designs, gages, fixtures, and facilities.
- 5 79 6748 SCAMP POLLUTION ABATEMENT
The pollutants produced by SCAMP lines have been investigated under project 57X4114, subproject =2. When complete, in FY77, a recommended abatement system will result. This system must be tested.
- 5 79 6760 DRYING OF LOW DENSITY BALL PROPELLANT
Low density ball propellant is low in weight, high in moisture content and more hazardous than conventional ball propellant thus creating a number of problems in drying process.
- 5 79 6774 MANUFACTURING METHODS FOR APDS PROJECTILE-25MM-MICV
The existing process for manufacturing the 25MM (MICV) APDS projectile are inefficient and labor intensive. The present methods can not meet required production rates.
- ARRADCOM-ARRCOM (WPNS)
- 6 78 7726 APPLICATION OF COLD AND WARM ROTARY FORGE
Processing parameters for warm and cold forging are not available.
- 6 78 7933 CENTRAL COOLANT SYSTEMS
Machines are used intermittently, lack of agitation allows stagnation and consequently, a bacteria build up, at individual machine sites, proper maintenance is difficult.
- 6 78 8043 IMPROVED MACHINING PROCEDURES FOR DOVETAILS
Close tolerance dovetails are required to assemble recoil rails on large caliber weapons. Extreme care is required when milling to avoid cutting oversize.

PROJECTS ADDED IN SECOND HALF, CY78 (Continued)

- 6 78 8045 IMPROVED TUBE STRAIGHTENING
Tube straightening is an art which requires years of experience for development of proficient operators. Operators are limited by difficulty in monitoring and controlling of straightening operations regardless of experience.
- 6 78 8047 PASS THRU STEADY RESTS FOR TUBE TURNING
Roller rests provide necessary support for gun tube turning but it will not allow turning full length in one set up. Present method is to use two lathes with two set ups or lathe must have two carriages.
- 6 78 8048 IMPRVD INSPECTION TECH F/INGOTS & PREFORMS F/ROTARY FORGING
Current technique of inspection of ingots is time consuming and prone to error. Each ingot or preform must satisfy an internal soundness requirement. Ultrasonic inspection is necessary.
- 6 78 8049 MANUFACTURING PROCESSES ENERGY CONSERVATION PROGRAM
As the price of utilities and fuels continue to increase the possibility of curtailment in utilities during the winter months increases. Conscientious energy conservation efforts are required.
- 6 79 7213 HIGH SPEED CHROMIUM PLATING TECHNIQUE
Chromium plating techniques are slow because the equipment is slow.
- 6 79 7246 SIMPLIFICATION OF BREECH RING MFR AND HANDLING
A prior year study has identified many areas where cost reductions are possible in the mfg of the 105MM M68 breech ring.
- 6 79 7317 OPTIMIZATION OF STEP THREAD TOOLING
Much of the tool is lost due to limitations of sharpening. The cutter blades should be evaluated in an attempt to obtain more durable and readily grindable steel.
- 6 79 7482 MODIFIED RIBBON RIFLING GENERATING MACHINE
Rifling of gun tubes requires an excessively long honing time.
- 6 79 7555 DYNAMIC PRESSURIZATION STAND, SLIDE BLOCK BREECH MECH
High testing costs for proof firing slide block breech mechanisms.
- 6 79 7605 CHEMICALLY BONDED SAND FOR CLOSE TOLERANCE CASTING
Present methods of molding and core making are costly, energy wasteful, and unsuitable for holding close tolerances.
- 6 79 7724 GROUP TECHNOLOGY OF WEAPON SYSTEMS
There is a need to reduce and control the proliferation of designs and parts in manufacturing system.

PROJECTS ADDED IN SECOND HALF, CY78 (Continued)

- 6 79 7726 APPLICATION OF COLD AND WARM ROTARY FORGING
Processing parameters for warm and cold forging are not available.
- 6 79 7727 RECYCLING OF SCRAP GUN TUBES BY ROTARY FORGING
Fired out and demilitarized gun tubes are now being sold as scrap thus wasting valuable gun tube material.
- 6 79 7730 MANUFACTURE OF SPLIT RING BREECH SEALS
Split rings require precise mfg. Present methods are outdated and costly requiring much hand finishing by highly skilled workers. Rejection rate high with much rework.
- 6 79 7802 ESTABLISH MACHINE TOOL PERFORMANCE SPECIFICATIONS
Performance capability of production machine tools is not known.
- 6 79 7807 PROGRAMMED OPTICAL SURFACING EQUIPMENT AND METHODOLOGY
Production quantities required for any given military optic are small. Thus, cost saving possibilities of mass production are not available and other means of cost reduction must be sought.
- 6 79 7948 ESTABLISH CUTTING FLUID CONTROL SYSTEM
The lack of a controlled program for the use of cutting fluids results in high machining costs and stocking of many fluids.
- 6 79 7949 APPLICATION OF GROUP TECHNOLOGY TO RIA MFR-CAM-1ST INCR
Present planning, scheduling, and manufacture of weapon assemblies and components are by separate lots and parts which require multiple, machining operation, set-ups and changes of tooling, and cause loss of time and money.
- 6 79 7963 GROUP TECH & CELLULAR MFR FOR FC COMPONENTS & ASSEMBLIES
Fire control manufacturing has resulted in the proliferation of manufacturing information, long set-up times or multiple resetting of machines, under-utilization of machines, long and uncertain throughput times, and high work-in progress.
- 6 79 7965 DIFFERENTIAL SCATTEROMETRY FOR MICROFINISH SURFACES
Current use for determining lens surface roughness requires removal of lens block from production unit to separate piece of equipment. This decreases utility of the method.
- 6 79 8004 CO-DEPOSITION OF SOLID LUBRICANTS DURING ANODIZING
Low friction, hardcost surfaces are needed for aluminum components.
- 6 79 8005 ESTABLISHMENT OF THE SPACE MECHANICAL PLATING PROCESS
Electrochemical or chemical processes to coat steel ordnance items introduce hydrogen which cause embrittlement.

PROJECTS ADDED IN SECOND HALF, CY78 (Continued)

- 6 79 8010 PRODUCTION OF ACOUSTIC MICROWAVE FILTERS
Acoustic microwave filters can be produced under laboratory conditions at the rate of 1 to 2 per month. A production method capable of producing approximately 30 per day is needed.
- 6 79 8017 POLLUTION ABATEMENT PROGRAM
More stringent environmental requirements are being established for air and waste water discharge.
- 6 79 8025 ELECTRONIC PROFILE READOUT GAGE FOR POWDER CHAMBER CONTROLS
Powder chamber size is checked by 4-6 flush pin gages each weighing about 35 lbs. From each check, machine adjustments must be made to machine chamber to required spec.
- 6 79 8107 CREEP FEED CRUSH FORM GRINDING
The bracket slot on the 105MM m68 breech ring is a high cost operation. It is currently milled with form tools in two operations-rough and finish.

DARCOM

- D 79 5052 ARMY ENGINEERING DESIGN HANDBOOK FOR PRODUCTION SUPPORT
Technical scientific and engineering data is continually being generated within the Army and needs to be collected in appropriate documents.

MERADCOM

- E 79 3532 MOLTEN SALT LI/CL BATTERY
Present lead acid and nickel iron batteries often need recharging in order to complete an eight-hour shift.
- E 79 3604 SOLID STATE POWER SWITCH
There is no production base for solid state power switch. The nature of this device is such that no manufacturing technology or method exists for the unique assembly requirements.
- E 79 3605 TRANSCALENT-HIGH POWER-TRANSISTOR
Currently available solid state power devices of required ratings and their heat sinks often are too heavy and bulky to be conveniently used in compact, lightweight power conditioners.
- E 79 3606 250 AMP TRANSCALENT HIGH POWER RECTIFIER
There is no production source available for the transcalent (high power) rectifier for use in solid-state power processing circuits and systems.
- E 79 3613 VEHCILE-MOUNTED ROAD MINE DETECTOR SYSTEM ANTENNAS
The fabrication of these antenna modules is by manual operation and is labor cost excessive.

PROJECTS ADDED IN SECOND HALF, CY78 (Continued)

- E 79 3708 COATED FABRIC COLLAPSIBLE FUEL TANK-CIRCULAR SEAMLS WEAVING
To improve the reliability and endurance of fabric pillow tanks by eliminating the longitudinal seams which are vulcanized together. These seams are the most likely cause of catastrophic failure.
- E 79 3709 CONTINUOUS LENGTH FUEL HOSE
A large portion of the cost of continuous length fuel hose is attributed to splicing the hose every 50 feet. 100 grains size, pyrophoric material must be bonded to steel fragments and produced in great numbers for the system.
- E 79 3743 COMPOSITE SPUN MATERIAL LAUNCHING BEAM FOR BRIDGES
Conventional materials, steel and aluminum, cannot fulfill the operational requirements imposed on them in future military bridging.
- E 79 3745 ALUMINUM-GRAPHITE EPOXY SANDWICHED BRIDGE REINFORCEMENT
Current materials cannot be expected to show quantum improvements in operating characteristics and weight reduction.
- E 79 3756 COMPOSITE MATERIAL GIRDER MODULES FOR BRIDGES
Reduce weight and cost of bridge while increasing fatigue life. Increase bridge span and load class without a weight increase.
- E 79 3759 KEVLAR CABLE REINFORCEMENT FOR MILITARY BRIDGES
There is now a massive weight penalty required in the manufacture of cables with built-in pin socket connectors.

CORADCOM

- F 79 9784 RUGGEDIZED TACTICAL FIBER OPTIC CABLE ASSEMBLIES
Applying a protective coating onto each fiber has not been done in production quantities. Bundling the fibers and applying a plastic sheath must be worked out.
- F 79 9891 ARCTIC (-55 C) ELECTRICAL CABLE JACKET
Insufficient demand for low temperature electrical cable has caused the sole producer to halt production.
- F 79 9938 THREE COLOR LIGHT EMITTING DIODE DISPLAY UNIT
Present manufacturing methods are too costly and complicated since many components have to be interconnected and mounted by hand.

PROJECTS ADDED IN SECOND HALF, CY78 (Continued)

ERADCOM

- H 78 3511 FAB OF SUBMICRON PHOTOMASKS FOR INTEGRATED CIRCUIT DEVICES
Existing technology limits line widths to 0.8U. Integrated circuits and special systems require a 0.5U line width to increase yield and allow higher frequencies.
- H 78 9738 PULSED GA AS IMPATT DIODES
There are no rugged, low-cost reliable microwave sources and amplifiers for army application.
- H 79 9805 QUARTZ CRYSTAL PARAMETER TESTING
The crystal impedance meter requires updating to allow accurate measurement of crystal characteristics, regardless of temperature and frequency.
- H 79 9807 MMT FOR PROCESSING HIGH STABILITY QUARTZ CRYSTAL UNIT
Stresses due to crystal mounting, bonding, and electroding, plus mass transfer of contaminants within the enclosure cause reduction in crystal stability.
- H 79 9844 CMOS CIRCUITS USING SILICON ON SAPPHIRE -SOS-TECHNOLOGY
Thermal imaging systems now require a lead from each detector element to an amplifier located outside the cooled detector dewar.
- H 79 9853 LEAD TIN TELLURIDE DETECTOR/DEWAR MODULES
Tin lead telluride detector arrays are difficult to make because conducting paths must be formed into the substrate along with required circuitry. Yields are low.
- H 79 9869 RAPID REMOVAL OF PLASTIC ENCAPSULANTS
Defective electronic modules and potted circuit boards must have the compounds removed to get at the defective component. This is a slow, tedious process.
- H 79 9877 MMT FOR LIGHT EMITTING DIODE ARRAY COMMON MODULE
A lot of hand assembly, wiring, testing, and resistor trimming is used in building LED modules.
- H 79 9893 ADVANCED METHODS FOR FABRICATING MICROCHANNEL PLATES
Microchannel plates are now made by fusing together thousands of coated glass fibers then etching out the glass. Cracking occurs from fiber redrawing.
- H 79 9963 LOW COST E-BEAM EQUIPMENT
Electron beam photolithography is needed for defining artwork, photo-masks, or direct exposure on a wafer where close definition is essential. It is costly because present equipment is designed for large area exposure and high throughput.

PROJECTS ADDED IN SECOND HALF, CY78 (Continued)

AMMRC

- M 78 7590 ESTABLISHMENT OF PRODUCTION BASE FOR WATTS CASTING PROCESS
- M 79 6350 MATERIALS TESTING TECHNOLOGY (MTT)
Destructive and certain conventional non-destructive testing techniques are respectively unsuited and inadequate or hard to be adapted to on-line production testing usage.

MIRADCOM-MIRCOM

- R 78 3396 INJECTION MOLDING OF ONE PIECE NOZZLES
Rocket motors as alternatives to tube artillery are too costly.
- R 79 3116 IMPROVED PDN METHOD FOR ROSETTE AD SEEKER OPTICS & DETECTOR
Very dense packaging makes assembly very costly.
- R 79 3136 IMPROVED MFR PROCESSES FOR COMPLIANT BEARING GYROS
The present method of manufacture is too expensive for volume production.
- R 79 3142 PRODUCTION METHODS FOR LOW COST PAPER MOTOR COMPONENTS
High volume missiles and rockets use high strength to weight metal motor cases which are a costly item.
- R 79 3146 HIGH DENSITY MULTILAYER THICK FILM HYBRID MICRO CIRCUITS
Screen printing of fine lines does not allow high density due to rheology of ink systems.
- R 79 3160 CLEANLINESS & PROCESS CRITERIA FOR CIRCUIT BOARDS
Criteria for PCB cleanliness is vague and costs associated with it are a high percentage of final product cost.
- R 79 3217 AUTOMATED PRODUCTION METHODS FOR TRAVELING WAVE TUBES
The SAM-D TWT is the most expensive component in the guidance system and is a significant system cost driver. A fundamental change of concept in the manufacturing process is required.
- R 79 3219 AUTOMATIC POLYMER ATTACHMENT PRODUCTION METHODS
Present technology employs a polymer dispensing machine which is operated manually, a time consuming and costly process.
- R 79 3242 DIGITAL FAULT ISOLATION OF PRINTED CIRCUIT BOARD
Dense missile digital electronic systems require a significant improvement in digital fault isolation costs and schedule delays.
- R 79 3253 HIGH CURRENT DENSITY CATHODES
Thermionic cathodes have heating and cooling problems. High operating temperatures reduce the lifetime of the cathode.

PROJECTS ADDED IN SECOND HALF, CY78 (Continued)

- R 79 3267 PDN PROC FOR REMOVING EPOXY SMEAR IN PLATED-THROUGH HOLES
Removal of epoxy smear to plating thru holes is costly.
- R 79 3268 AUTOMATIC CONTROL OF PLATING (CAM)
Manual control methods cannot maintain the tight tolerances that are required.
- R 79 3272 FLEX PRINTED CIRCUITS WITH INTEGRAL MOLDED CONNECTORS
Manufacture of conventional round wire cabling with connectors is largely a hand labor item.
- R 79 3280 ENGR ANALYSIS OF MFG PARAMETERS FOR THERMAL BATTERIES
Slight variations in manufacturing parameters have greatly magnified effect on final battery performance as a result rejection rates are high.
- R 79 3372 DEV & EVAL OF MFR METHODS FOR MAGNETIC MATERIALS
New magnetic devices present many manufacturing problems from application of the insulation system to displacement of winding locations and tension.
- R 79 3381 LOW COST, IMPROVED 2-D HEAT SHIELDS
Heatshield fabrication by tape wrapping is low speed, high cost process.
- R 79 3410 PRODUCTION METHOD FOR HEAT PIPES FOR HYBRID/LSI
The use of micro-electronics and LSI circuitry often times leads to heat dissipation problems.
- R 79 3438 DELIDDING, PARALLEL SEAM SEALED HYBRID MICROELECT PACKAGES
There is no production techniques or equipment available to accomplish delidding of hybrid packages.
- R 79 3441 APPLICATION OF HIGH ENERGY LASER MANUFACTURING PROCESSES
Cost is a critical factor in conventional welding associated with manufacture of high volume missile systems such as containers, launchers, etc. The implementation of laser processes has the potential for enormous cost savings.
- R 79 3444 FULLY ADDITIVE MANUFACTURING FOR PRINTED WIRING BOARDS
The present subtractive method of producing circuit boards is wasteful of copper slow and expensive.
- R 79 3445 PRECISION MACHINING OF OPTICAL COMPONENT
Existing precision machining facilities cannot keep up with the demand, meet optical design requirement, meet production schedules, and stay within reasonable cost boundaries.
- 3 79 3115 ENGINEERING FOR METROLOGY AND CALIBRATION
Measurement sciences or metrology must be continually advanced in relevant technology areas to keep pace with many army programs.

PROJECTS ADDED IN SECOND HALF, CY78 (Continued)

TARADCOM-TARCOM

- T 78 5009 FORGING OF LARGE ARMOR SECTIONS FROM FORGED PREFORMS
Improved availability of preforms is needed.
- T 78 6023 FABRICATION OF FLAT THIN GAGE ALLOY STEEL PLATE
Current production proc result in plates which are not sufficiently flat to permit assembly into the vehicle structure without additional processing by the vehicle manufacturer.
- T 78 6035 ESTABLISH ON-LINE NDT FOR TRACKED COMBAT VEHICLES (PHASE 1)
Extensive in-process NDT of many XM-1 components will be essential during production to assure compliance with designated quality control requirements.
- T 79 4389 PDN OF FOLDABLE PLASTIC TOPS FOR SOFT TOP TRUCK CABS-PH 1
Canvas tops and backs afford minimum comfort and environmental protection. Replacement is often necessary.
- T 79 4575 LASER WELDING TECHNIQUES FOR MILITARY VEHICLES
No manufacturing baseline exists for welding high strength material by advanced high-speed welding techniques.
- T 79 4586 IMPROVED LARGE ARMOR STEEL CASTING- PHASE 1
Present casting techniques need updating in order to exploit the advantage of casting process.
- T 79 5002 FABRICATING TORSION SPRINGS FROM HIGH STRENGTH STEELS
Engineering alloy steels can be heat treated to a maximum working hardness which requires large diameter bars thereby interfering with design fits and increasing weight.
- T 79 5006 PRODUCTION OF LIGHTWEIGHT STEEL CAST TRACK SHOES
The most costly item to maintain per mile of tracked vehicle operation is the track.
- T 79 5007 ADVANCED TECHNOLOGY BRAKE LINING MATERIALS-PHASE 2
Brake lining materials are subject to thermal shock and mechanical wear and must have good dampening capacity. This is difficult to achieve. Wear systems are sacrificed. Contamination by foreign substances causes brake failure.
- T 79 5024 GEAR DESIGN & MFR UTILIZING COMPUTER TECHNOLOGY, CAM-PH 2
Proper tooth pattern of bevel gears must be made by trial and error.
- T 79 5045 SPALL SUPPRESSIVE ARMOR FOR COMBAT VEHICLES-PHASE 1
Current metallic armor does not suppress flying shrapnel within the vehicle crew compartment.

PROJECTS ADDED IN SECOND HALF, CY78 (Continued)

- T 79 5054 LASER SURFACE HARDENED COMBAT VEHICLE COMPONENTS-PHASE 1
Present methods of surface hardening inputs heat over large surface area.
- T 79 5064 LIGHT WEIGHT SADDLE TANK-PHASE 2
Fabricate an economical high impact non-metallic fuel tank.
- T 79 5067 PLASTIC BATTERY BOX
Metallic battery boxes are subject to corrosion, thereby, damaging the vehicle.
- T 79 5080 HIGH STRENGTH NEAR NET SHAPE ALUMINUM TRANSMISSION CASES
Trans cases are bulky and need complex fabrication and machining.
- T 79 5081 FABRICATION OF FRICTION RINGS AND REACTION PLATES-PHASE 2
Fab of friction rings and reaction plates results in large amounts of scrap material thus contributing to high cost.
- T 79 5082 FLEXIBLE MACHINING SYSTEMS PILOT LINE FOR TCV COMPONENTS
Machining relatively small quantities by on-line method is inefficient and uneconomical.
- T 79 5083 UPSCALING OF ADVANCED POWDERED METALLURGY PROCESSES-PHASE 3
Powder metals processes have not been utilized in large components.
- T 79 5088 HIGH POWER ELECTRON BEAM WELDING IN AIR PHASE 1
Use of electron beam has not been exploited.
- T 79 5090 IMPROVED AND COST EFFECTIVE MACHINING TECHNOLOGY
Machine data on newer materials and new removal rates are not established.
- T 79 5094 ARMOR STEEL TREATED WITH RARE EARTH ADDITIONS
Armor steels utilized conventional peoxidizing and scavenging processes in steel making.
- T 79 6000 LIGHT WEIGHT TILT-UP HOOD FENDER ASSEMBLY-PHASE 1
Current hood/fender assembly made from steel stampings are too heavy for one man to lift.

TOTAL PROJECTS ADDED IN SECOND HALF, CY78

181

PROJECTS COMPLETED IN SECOND HALF, CY78

TECOM

- 0 7T 5071 IMPROVEMENT OF PRODUCTION TEST METHODOLOGY
See individual subtask below for status.
- 0 7T 5071A ACCEPTANCE TEST PROCEDURES
Subtask completed - 19 ATP were completed and published.
- 0 7T 5071B FUNDAMENTALS OF RICOCHET
Ricochet tests of the 175MM HIMAG APFSDS, projectile were completed and the data is being reduced for analysis. Firings have been delayed as suitable ranges and technical support personnel have not been available.
- 0 7T 5071C TEST OPERATIONS PROCEDURES
Twenty-five tops were completed and submitted to HQ, TECOM.
- 0 7T 5071D HARD MOUNT USAGE FOR MORTAR AMMO TESTING
The requirement for a standard hard mount for testing of mortar ammunition was based on observed variations in performance at different sites. It was determined that variations were not related to the baseplate so the project was terminated.
- 0 7T 5071E IN-TANK FUEL TEMPERATURE IN ARMORED VEHICLES
Measurements were obtained on M60A1 and M11341 vehicles. It was concluded that temperature-time profiles can be generated during endurance test cycles. TOP2-2-607 will be revised.
- 0 76 5071 IMPROVEMENT OF PRODUCTION TEST METHODOLOGY
See individual subtask below for status.
- 0 76 5071C AUTOMATIC DATA COLLECTION SYSTEMS FOR AIR CONDITIONER
Electronic analog instrumentation has been installed to test military A.C. equip. The results show slight discrepancies. However, the repeatability on the new equipment was excellent.
- 0 76 5071D IMPROVED TRANSPORTABILITY TEST CAPABILITIES
A revision of TECOM TOP 1-2-500 incorporated the use of the computer program, (SEO 276,00) has been approved. A requirement for new landship facility has been forwarded to facilities for construction approval. The approval is expected by April 1979.
- 0 76 5071S APPLICATION OF DATA BASE TECHNOLOGY TO WORKLOAD SCHEDULING
The results of this subtask provides a basis for workload scheduling, overtime management and resource distribution. The system is applicable throughout TECOM and represents a model for a second generation test resource management system.

PROJECTS COMPLETED IN SECOND HALF, CY78

AVRADCOM

- 1 76 7046 PRECISION CAST TITANIUM COMPRESSOR CASING
All technical work has been completed. A draft final report has been submitted and is being reviewed. Two engine casings have been successfully engine tested. The TDP is being prepared.
- 1 76 7114 IMPROVED MFG TECH FOR INFRARED SUPPRESSION ON AIRCRAFT
Critical process parameters of vacuum required, sealing, deflector design, ram pressure, and holding fixture design were established and the first sample part produced. No further work will be done as project funds were closed out.
- 1 78 8045 FIBER REINFORCED PLASTIC HELICOPTER TAIL ROTOR ASSEMBLY
In view of the termination of the contract on 1 76 8045, the contract monies for this project have been deobligated. The remainder of the funds have been expended in support of PW 1 76 8045.
- 1 74 8120 IMPROVED MCPTR SKIN MATL BY CONTROLLED SOLIDIFICATION & TMT
The results of this program show that intermediate thermal-mechanical treatment is a technique for improving the properties of 7XXX series aluminum forgings and that it is a cost-effective means of saving weight in helicopter components.

ARRADCOM-ARRCOM (AMMO)

- 5 75 1248 EVAL EXHAUST FILTER SYSTEM TO ESTABLISH DESIGN CRITERIA
Data was obtained comparing agent adsorp capacity of carbon beds for M11 canister. Predicted and actual gas performances were determined for 4 GVT gas filters and 2CML filters vs 5 chemical agents. Dual filter system for monitoring air was tested.
- 5 75 1250 EVALUATE WHITE PHOSPHOROUS LEAK DETECTION PROTOTYPE
An induction heating system with a flame-emission detector was developed for leak testing WP filled items. 400 WP 2.75 rocket warheads were tested with no leakers detected. No leakers were detected during a comparative batch oven test.
- 5 76 1274 WHITE PHOSPHORUS DRY FILLING LINE
An automated fry fill line for white phosphorous was installed. Acceptance testing for 105MM M60 munitions and 2.75in M156 warheads was conducted with only one reject. Preoperational survey indicated conveyor and cleaning station problems.
- 5 75 1316 ADVANCED TECHNOLOGY FOR PROCESSING SMOKE GRENADES
Investigations established filling methods, pressing forces, ram speeds, increment size, determined maximum amt of filling material and minimum reqmts for control of dust. Developed a starter mix dipensing and vacuum cleaning station.

PROJECTS COMPLETED IN SECOND HALF, CY78 (Continued)

- 5 76 1336 PRODUCTION FILLING EQUIP TECH FOR WP MUNITIONS
An inertia welding and fill & weight station was installed. Weld parameters were established. The production configuration canister was calibrated with WP. A fill test program was conducted with 650 canisters. Data for fill station design was obtained.
- 5 7T 1337 ENGR STUDY F/ADAPT TRF OF UK TECH-LCHR SYS W/RP/BUTYL GREN
Drying studies were completed on the red P/Butyl mix. Hazards analysis using RP mix were completed with the planetary blender. Rubber shredders were evaluated and recommended.
- 5 76 3095 MORTAR-ARTY BLISTIC SIMULATIONS FOR FUZ TESTING
Completed project-A high spin tabletop artillery simulator resulted from this project. This simulator provides a reliable PS11K power supply testing unit. Two simulators have been constructed for production testing of PS115 power supplies.
- 5 75 4032 AUTOMATED EQUIP FOR ASSEMBLY OF M572E2 FUZE
The project is technically complete. See project 5 76 4032.
- 5 76 4032 AUTOMATED EQUIP FOR ASSEMBLY OF M572E2 FUZE
The project is technically complete. Fourteen prototype automated machines are currently being used for production of the M739 fuze.
- 5 75 4041 AUTO EQUIPMENT FOR ASSY OF MORTAR COMPONENTS
The FY75 program was completed. The automated propelling charge LAP equipment was designed. Propellant charge container and packaging test items were procured.
- 5 78 4148 REDUCED WEIGHT FORGING FOR THE 8 INCH MOTOR BODY, XM650
A lightweight forging was successfully produced and determined to be acceptable. 400 rough forgings were made to prove reproducibility and determine tool wear characteristics. These forgings are available for future government use.
- 5 7T 4165 PROT FAC FOR HMX RECOVERY FROM RDX/HMX ADMIXTURES
A prototype HMX recovery plant was constructed and operated from Feb 77 to Jun 77. The feasibility was demonstrated. Only control of the HMX content in the crude RDX would provide the yield and purity desired.
- 5 74 4201 SAFETY ENGINEERING IN SUPPORT OF AMMUNITION PLANTS.
Chemical mixtures in selected process components from TNT facilities were tested. TNT equivalency testing of M30A1 prop was conducted. Testing was conducted on the effects on explosive items to impact by concrete secondary fragments.
- 5 74 4223 APPLICATION OF ULTRASONIC ENERGY TO DOUBLE-BASE PROP PROC
A fractured dieholder was replaced into the 15 inch press assembly. It was determined that electrical component failures could be solved and will be with FY77 funds.

PROJECTS COMPLETED IN SECOND HALF, CY78 (Continued)

- 5 76 4228 AUTOMATED BAG LOADING/CHARGE ASSEMBLY & PACKOUT-155MM/8IN
Line continues to be debugged. Assembly machine controls were rewired. Air logic system was developed for charge insertion station. Other work areas included can marking machine can insertion station, panel wiring, scale system & telewriter unit.
- 5 77 4228 AUTOMATED BAG LOADING/CHARGE ASSEMBLY & PACKOUT-155MM/8IN
Debugging continued. Sewing machine & thread cutter modules were completed. Air logic changes were made to assembly machine and packout line. Work on 16-LB scale terminated. Remaining work on scale system and carousel was brought to a conclusion.
- 5 76 4237 CONTINUOUS TNT PROCESS ENGINEERING
The equipment and piping for the TNT Pilot Plant were installed. Modifications were made to adapt the control room's digital computer, analog controls and programmable controller to the specific operational tasks for the TNT Pilot Plant.
- 5 75 4240 INVESTIGATION OF LOADING AMATEX-20
Special IPR decided TNT will be alternate fill and work on AMATEX be terminated. Spec grade AMATEX 20 MFRD at HAAP. Systems and economic analysis completed by IITRI. Eqmt and process hazards identified. Loading at IAAP showed better PDN control needed.
- 5 76 4240 INVESTIGATION OF LOADING AMATEX-20
AMATEX 20 was successfully processed thru continuous melt pour eqmt. Concept to pump AMATEX 20 was eliminated. Design parameters obtained for mechanical crushing to prepare AMATEX 20 for reuse. Conceptual layouts for the MFR process at LAPS prepared.
- 5 7T 4252 IMPROVE PRESENT PROCESSES FOR MFG RDX AND HMX
Production prove-out with crude acetic anhydride has shown that RDX produced has no changed in quality or yield. Crude acetic anhydride for the mfr of RDX can be employed at HAAP and at any new facility.
- 5 76 4271 IMPROVED PROCESSES TO POLISH, DRY, AND GLAZE BLACK POWDER
Test runs with the intermediate scale harperizer provided a scale-up of the process operations for the prototype. The harperizer system reduces black powder being polished, glazed and dried from 10, 500 lb in 3 houses to 800 lb total in 1 glaze house.
- 5 76 4291 BLAST EFFECTS IN MUNITION PLANT ENVIRONMENT
Tests and reports completed. New safety design criteria to be included in approp regulations and manuals. For details see AMCR 385-100 TM-1300 ARLCD-CR-78016 and 77008 and PA-TR-5009.

PROJECTS COMPLETED IN SECOND HALF, CY78 (Continued)

- 5 76 4300 PRODUCT ASSURANCE IN SUPPORT OF AMMUNITION PLANT MODERNIZATION
Report on procurement of automated, mechanical, chemical and process controllers was forwarded to PM-PBM. Guidance was issued regarding preparation analysis of prove-out plans. Prove-out report on M483 LAP line at Kansas AAP was issued.
- 5 76 4327 AUTOMATIC X-RAY INSPECTION SYSTEM-AXIS
This project is a fiscal close-out. See project 5 77 4327 for continuing status.
- 5 7T 4435 OPR PROTYF SYS FOR 105MM M67 PROP CHG MOD
Project completed, 105MM prop charge loading booth was tested at INAAP. Test was basically successful. Modifications will be implemented by facilities projects 5 77 2500 and 5 78 2500.
- 5 76 4456 MATERIALS PROPERTY DATA INFORMATION SYSTEM
Project completed. Fund cut prevented overall objectives from being attained. System fulfills the needs for a broad range of computerized projects.
- 5 75 6562 CONTINUOUSLY CAST STEEL FOR AMMO METAL PARTS MFG
Continuously cast steel with a 4 to 1 reduction has been found to be acceptable for making projectile bodies.
- 5 77 6777 DEVELOPMENT OF PROD PROC- 105MM XM710E1 PROJECTILE METAL PTS
A process has been developed for producing the XM710E1. The production of the XM710E1 has been cancelled.

ARRADCOM-ARRCOM (WPNS)

- 6 74 6771 DESIGN AND CONSTRUCT REFINED STEP THREAD MACHINE
Eight breech rings have been step threaded on the fairfield step threading machine, inspected, and found to meet all drawing requirements. A final report is being finalized. The equipment will be moved to the 175MM/8 inch breech ring production line.
- 6 76 7201 ARTILLERY WEAPON FIRING TEST SIMULATOR
Under this year of funding the capabilities of the simulator were extended to four additional weapons (gun mounts). A second simulator is being built under MMT project 6 77 7201.
- 6 76 7203 APPL OF LEAST COST TOLERANCES AND FINISHES TO PROD OF GUN
All tests to establish the various parameters of surface and part specification tolerancing were completed. A final technical report has been completed.
- 6 76 7236 RAPID HEAT TREATING FOR CANNON TUBES
Project is complete. Results have been implemented at Watervliet. Savings of 43 dollars per M68 tube and 71 dollars per M186 tube have been realized.

PROJECTS COMPLETED IN SECOND HALF, CY78 (Continued)

- 6 73 7340 DETERMINATION/CERT OF IN-HOUSE ARMOR STEEL CASTING PROC
Project completed. Certification to cast one and two inch steel armor was obtained. Weld repair certification was not obtained.
- 6 74 7410 FINE BLANKING OF PRECISION SMALL CAL. WEAPON PART
Fine blanking was investigated and found to be a cost effective process when properly utilized. High carbon steels can be fine blanked if spheroidized, annealed, and is of the proper hardness.
- 6 76 7455 COMPUTER GENERATED MASTERS FOR GRAPHICAL FIRING TABLES
Masters for graphical firing tables were fabricated using computer software and an automated drafting machine. By varying quadrant elevation and scale, 8 masters for the 4.2 inch M30 mortar were acceptably generated. Final report is being released.
- 6 75 7555 DYNAMIC PRESSURE STAND, SLIDE BLOCK BREECH MECHANISMS
Gymnasticator has been installed and debugged. Perf reports, operation manuals, and final report are completed. Phase 2-FY79 funding-will provide sophisticated instrumentation and further increase savings.
- 6 77 7742 SPOT CURING PRECISION OPTICAL ASSEMBLIES
Cure parameters for the ferro-allied UV curing unit 3040 are 2 minutes in fixture and 2 minutes out at 18 inches from bulb to adhesive layer. Experiment in interrupted curing was conducted. Short controlled cure is imperative for high production.
- 6 77 7747 INJECTION MOLDED PLASTIC FOAMS FOR SMALL ARMS APPL
Project work has been completed and funds expended without achieving a process for injection molding plastic foam small arm stocks. To establish this process additional funds will be necessary, however, plans have not been made to continue this work.

MERADCOM

- 7 76 3509 PRODUCTION TECHNOLOGY FOR SELF-LUMINOS LIGHT SOURCES
A final technical report is being prepared.
- 7 76 3551 THIN FILM COMPOSITE REINFORCEMENT
Work was completed. TI/AL and AL/Alumina films were formed and displayed tensile strengths of 540 KSI and 280 KSI. Problems were experienced in removing the films from the substrate which were not resolved. Additional work is recommended.
- E 77 3588 SLUFAE MINE NEUTRALIZER LAUNCHER
ALCOA has successfully demonstrated the feasibility of producing close tolerance large diameter tubes by the drawing (cold worked) process. This technique will provide a rocket launcher tube which is larger than current industry standards.

PROJECTS COMPLETED IN SECOND HALF, CY78 (Continued)

ERADCOM

- 2 76 9732 FABRICATION & ATTACHEMENT OF HEAT PIPES TO THYRISTER WAFERS
RCA developed production fixtures and procedures for metallurgically bonding heat pipes to metallized silicon wafers. Used high temperature brazing, sintering of metal wicks and ceramic to metal sealing. Strong commercial interest is shown complete.
- 2 74 9750 FAB OF 18MM IMAGE INTENSIFIER TUBES BY BATCH PROCESSING
Litton processed image tubes on both its 5 and 10 port systems. The 5 port unit had better time cost figures because of its lower volume for pumpdown. Litton built an 8 port unit with mass and volume of the 5 port unit and will phase it into production.
- H 79 9853 LEAD TIN TELLURIDE DETECTOR/DEWAR MODULES
This project was to fabricate (lead - tin - telluride) modules with high yield at a production line rate. It was cancelled and money was made available for higher priority projects.
- H 79 9893 ADVANCED METHODS FOR FABRICATING MICROCHANNEL PLATES
The project was cancelled to make funds available for projects with higher priority. Increased automation, increased yields and competition are reducing prices of micro channel plates. These factors will reduce savings impact of this project.

AMMRC

- M 77 6370 OPTIMIZATION OF MMT PROGRAM EFFECTIVENESS
Project completed. Funds mipe'd to defense electronic supply center now given as \$7455.
- M 78 7590 ESTABLISHMENT OF PRODUCTION BASE FOR WATTS CASTING PROCESS
Project is being terminated.

MIRADCOM-MIRCOM

- R 77 3076 QTY PROD TECH FOR COMPOSITE ROCKET MOTOR COMPONENTS
This project has resulted in a successful process for the economical production of filament wound rocket motor components. A demo production run of 300 2.5 inch rocket case/nozzles has resulted in a unit cost of \$12. A final rept has been published.
- R 77 3121 APPLICATION AND NDT OF LINE PIPE FOR MOTOR COMPONENTS
Phase 1-6 of the project has been completed and the second year work has been initiated. An interim report is being prepared covering the first year effort. The work is continuing under R 78 3121.

PROJECTS COMPLETED IN SECOND HALF, CY78 (Continued)

- 3 7T 3135 PROCESS DEVELOPMENT FOR CARBORANE MFG
A design TDP was prepared for a 30 thousand pound N-hexylcarborane facility. Site selected was NE of present callery facility. In house process improvement was developed but did not produce high quality prop. Toxicity data on boron CPDS compiled.
- 3 76 3135 PROCESS DEVELOPMENT FOR CARBORANE MANUFACTURE
This project was completed. A continuous process for the preparation of NHC was proven. A scale-up of the continuous process was initiated. Cost comparisons of various alternatives to manufacture NHC were prepared.
- 3 76 3141 FLUIDICS MANUFACTURING AND ASSEMBLY PROCESSES
The effort was completed. The etching process produced high quality laminates with consistent, reproducible results for stock thicknesses up to 15 mils. Diffusion bonding of uncoated all alloy SHIMS was obtained with highly consistent results.
- 3 76 3147 ADDITIVE PROCESSES FOR FABRICATION OF PRINT CIRCUIT BOARDS
Two forms of thin clad (peelable copper carrier and etchable aluminum carrier) and three types of bare boards were shown to meet all physical tests. The interim report has been received, reviewed and accepted.
- R 77 3165 PRODN PROCESS & TECHNIQUES FOR SEALING HYBRID MIC-CIR PACK
The design and drafting of the pneumatic fine leak test apparatus has been completed. The pneumatic gross leak tester had been fabricated. Design and drafting of the microcircuit carousel is finished.
- R 77 3170 REPLACEMENT OF TPH-8156 AND TPH-8159 PROPELLANT
All work on this project has been completed. The program is being continued under a similar FY78 funded effort.
- R 78 3170 REPLACEMENT OF TPH-8156 AND TPH-8159 PROPELLANT
Mixes of TPH-8159 and TPH-8156 repl propellants MSL-302 and MSL-303 have been processed in 20 gal and 300 gal mixes. Propellants have also been demonstrated in M-105 and M-106 rocket motor cases. All proc procedures, RM, and prop acceptances demonstrated.
- 3 76 3225 PROD METH FOR MOUNTING NON-AXIAL LEAD COMPONENTS
Martin Marietta developed the locasert to help insertion of package leads into holes in printed circuit boards. Martin also built a pantograph type insertion machine with X-Y control on the table. Industry has shown interest in the locasert.
- 3 7T 3287 PRODUCTION METHODS FOR LOW COST STRIP LAMINATE MOTOR CASES
Several NDT methods have been tested and applied for screening critical defects in production. A final report is now being prepared for this project. A 2nd year effort will be continued under R 79 3287 as soon as funds are appropriated.

PROJECTS COMPLETED IN SECOND HALF, CY78 (Continued)

- R 78 3452 LOW COST QUANTITY PRODUCTION TECHNIQUE FOR LASER SEEKERS
Martin Marietta is integrating the HELLFIRE seeker head and the COPPERHEAD electronic package. They evaluated known process problems and validated process improvements for use in the pilot production line.
- 3 76 3115 ENGINEERING FOR METROLOGY AND CALIBRATION
This is only a fiscal close-out. See project 3 78 3115 for continuing status.

TARADCOM-TARCOM

- 4 75 4330 FABRICATION OF ARMORED VEHICLES BY ELECTRON BEAM WELDING
Technical report no. 12358 has been received. This project has been completed.
- 4 76 4330 FABRICATION OF ARMORED VEHICLES BY ELECTRON BEAM WELDING
This project has been completed.
- T 77 4589 METRICATION
The joint TARADCOM/TARCOM metrication plan was approved by the TARADCOM command group. A generalized plan for metrication was completed. This is the final status report.
- T 78 5009 FORGING OF LARGE ARMOR SECTIONS FROM FORGED PREFORMS
Project has been terminated.
- T 77 5017 AUTO GAS METAL ARC WELDING OF ALUMINUM HULL STRUCTURE
This project is terminated.
- T 78 5017 AUTO GAS METAL ARC WELDING OF ALUMINUM HULL STRUCTURE
This project has been terminated. EDDY current seam tracking is not practical in aluminum welding.
- 4 77 5019 MAINTENANCE FREE STORAGE BATTERY-PHASE 1
Contract for low maintenance battery plastic container completed. Thirty-six prototypes, as required, have been received at TARADCOM. These prototypes will be evaluated in lab and field tests under Phase 2 of the low maintenance battery program 4 78 5019.

TOTAL PROJECTS COMPLETED IN SECOND HALF, CY78

73

MANUFACTURING METHODS AND TECHNOLOGY PROGRAM

SUMMARY PROJECT STATUS REPORT

MMT PROGRAM

SUMMARY PROJECT STATUS REPORT

The Summary Project Status Report for the MMT Program is provided by the Integrated Simulation and Project Funding studies. The accuracy of funding amounts is based on the individual contractual status report. The status of reported data is the best representation of data available at the time of the report or other contracts as they are provided. A portion of the report is provided.



43
PRECEDING PAGE BLANK-NOT FILMED

MANUFACTURING METHODS AND TECHNOLOGY PROGRAM

SUMMARY PROJECT STATUS REPORT

The Summary Project Status Report for each SUBMACOM is preceded by the tabulated SUBMACOM MMT project funding status. The accuracy of funding amounts is based on the individual semiannual status reports. The status as reported here is the IBEA condensation of information contained in the report or other comments as deemed useful. If a status report was not provided a pertinent comment was made so that the project would be printed.

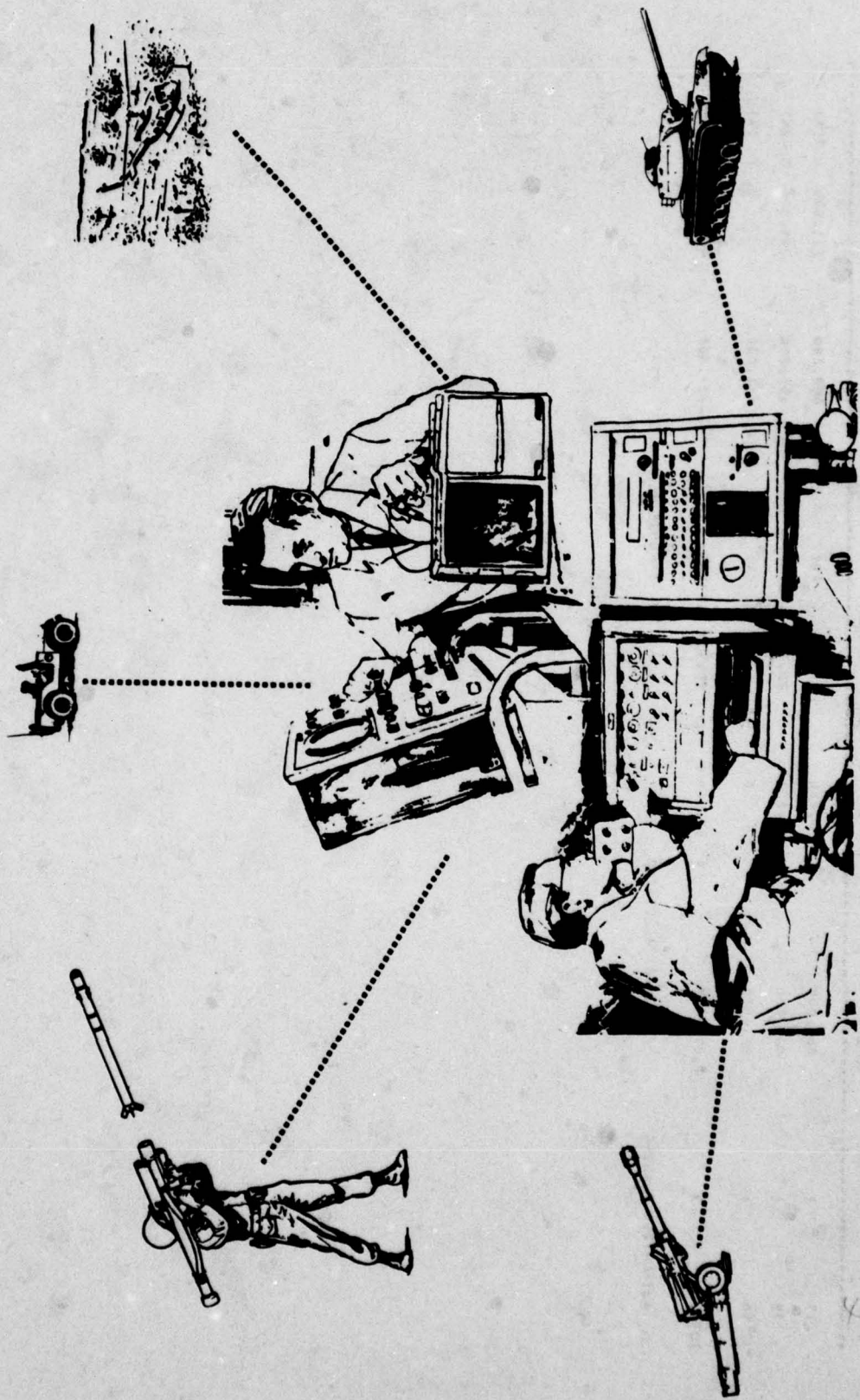

**TEST AND EVALUATION COMMAND
(TECOM)**

TEST AND EVALUATION COMMAND
CURRENT FUNDING STATUS, 2ND CY78

FISCAL YEAR	NO. OF PROJECTS	AUTHORIZED FUNDS (\$)	* CONTRACT FUNDS ALLOCATED (\$)	EXPENDED (\$)	(%)	* INHOUSE FUNDS ALLOCATED (\$)	EXPENDED (\$)	(%)
77	1	863,000	4,800	0	(0%)	858,200	611,000	(71%)
78	1	735,000	53,200	20,000	(37%)	681,800	291,000	(42%)
79	1	881,000	0	0	(0%)	881,000	0	(0%)
TOTAL	3	2,479,000	58,000	20,000	(34%)	2,421,000	902,000	(37%)

AUTHORIZED FUNDING

CONTRACT ALLOCATED 2%

INHOUSE ALLOCATED 97%

MANUFACTURING METHODS AND TECHNOLOGY PROGRAM
 SUBPROJECT STATUS REPORT
 2ND SEMI-ANNUAL SUBMISSION CY 78 RCS DRCHT-301

PROJ NO.	TITLE + STATUS	AUTOMATIZED	CONTRACT VALUES (\$000)	EXPENDED LABOR AND MATERIAL (\$000)	ORIGINAL PROJECTED COMPLETE DATE	PRESENT PROJECTED COMPLETE DATE
0 77 5071	IMPROVEMENT OF PRODUCTION TEST METHODOLOGY SEE INDIVIDUAL SURTASK BELOW FOR STATUS	A63.0	4.8	611.0	DFC 78	SEP 79
0 77 5071AA	IMPROVED MORTALITY MODEL TEST SUPPORT TASK WAS TERMINATED. NO CURRENT TESTING REQUIREMENT COULD BE IDENTIFIED.					SEP 79
0 77 5071AB	IMPACT SENSITIVITY OF FUZES PLANS FOR THE FIELD EVALUATION OF SEVERAL PROPOSED METHODS FOR SIMULATING THESE EFFECTS DURING PRODUCTION TESTS OF PROJECTILES ARE BEING PREPARED. THIS SURTASK HAS BEEN REPEATEDLY DELAYED BY A SHORTAGE OF PERSONNEL AND CONFLICTS WITH OTHER TESTS.					SEP 79
0 77 5071C	BACKSPALLING CHARACTERISTICS TEST FIRINGS WERE ACCOMPLISHED ON TWO TYPES OF DUAL HARDNESS STEEL ARMOR PLATE MEETING THE REQUIREMENTS OF MIL SPEC MIL-S-46099A. BALLISTIC TESTS WERE CONDUCTED AND IMPACT DAMAGE WAS RECORDED AND PHOTOGRAPHED. TASK IS CONTINUING.					SEP 79
0 77 5071F	METHODS OF HALOGEN LEAK DETECTION IT WAS DETERMINED THAT ELECTRONIC HALOGEN DETECTORS WHICH ARE COMMERCIALLY AVAILABLE ARE SUFFICIENTLY SENSITIVE AND ACCURATE TO PERFORM MILITARY LEAK CHECKS. AFTER MINOR MODIFICATION, IT WAS FOUND TO BE PRECISE AND RELIABLE FOR SPECIFICATION TESTS.					SEP 79
0 77 5071G	SMALL CALIBER WEAPON COOK-OFF TESTING FIRING TESTS OF THE M60E2 MACHINEGUN AND M16A1 RIFLE FOR THE COLLECTION OF COOK-OFF DATA UNDER VARIOUS CONDITIONS HAVE BEEN RESCHEDULED FOR 3RD AND 4TH QTRS, OF FY 79. A FINAL REPORT IS PROGRAMMED FOR JUNE 1979.					SEP 79
0 77 5071J	RISK IN ACCEPTING MATERIEL NOT CONFORMING TO EMI RMT IT WAS ESTABLISHED THAT THE EMI RISK ASSESSMENT TECHNIQUE USED BY THE ELECTRONIC PROVING GROUND SATISFIED AFG'S REQ. A WORKING ARRANGEMENT HAS BEEN ESTABLISHED TO TRANSMIT CURRENT EMI TEST DATA TO EPG AND FOR AFG TO UTILIZE THE EPG DATA ROUTINELY.					SEP 79
0 77 5071K	TEST OPERATIONS PROCEDURES TWENTY FOUR PROCEDURES WERE PRINTED AND DISTRIBUTED.					SEP 79
0 77 5071L	COOLING CAPACITY OF AIR CONDITIONERS AN ATTEMPT TO RESOLVE UNEXPLAINED VARIATIONS IN THE DISCHARGE COEFFICIENTS OF THE NOZZLES. THE LAMINAR FLOW ELEMENTS WERE CALIBRATED BY NRS. A 2000 CFM UNIT HAS BEEN INSTALLED AND CALIBRATED. OF THE PSYCHROMETRIC CELL FLOW-NOZZLES IS IN PROGRESS.					SEP 79

MANUFACTURING METHODS AND TECHNOLOGY PROGRAM
 S U M M A R Y P R O J E C T S T A T U S R E P O R T
 2ND SEMI-ANNUAL SUBMISSION CY 78 RCS DRGMT-301

PROJ NO.	TITLE + STATUS	AUTHORIZED (\$000)	CONTRACT VALUES (\$000)	EXPANDED LABOR AND MATERIAL (\$000)	ORIGINAL PROJECTED COMPLETE DATE	PRESENT PROJECTED COMPLETE DATE
0 77 5071N	SMOKE-CRSCURANTS TASK WAS COMPLETED-THE TECHNIQUES DEVELOPED WERE USED FOR THE CHARACTERIZATION AND EVALUATION OF FOREIGN AND INVENTORY SMOKE MUNITIONS AS WELL AS THE EVALUATION OF THE DEVELOPMENTAL 155 SMOKE MUNITIONS.				DEC 78	SEP 79
0 77 50710	SALT FOG TEST PROCEDURES TASK WAS COMPLETED-IT WAS DETERMINED THAT THERE IS A NEED FOR NEW TEST PROCEDURES TO IMPROVE THE VALIDITY OF SALT TESTING. THE DEVELOPMENT OF THIS PROCEDURE WILL BE A JOINT EFFORT BY APG AND THE TROPIC TEST CENTER.				DEC 78	SEP 79
0 77 5071R	GUN AIR DEFENSE SYSTEM TEST AND EVALUATION THE NEED FOR SPECIAL INSTRUMENTATION FOR TESTING THE DIVISIONAL AIR DEFENSE SYSTEM (DIVADS) HAS BEEN ESTABLISHED AND DETAIL REQ. FOR PRECISION AND ACCURACY ARE UNDER STUDY.				DEC 78	SEP 79
0 77 5071U	IFF SYSTEM THE CONTRACTOR SUBMITTED A DRAFT REPORT FOR REVIEW AND COMMENTS. TECOM PROVIDED THE CONTRACTOR WITH REVIEW COMMENTS.				DEC 78	SEP 79
0 77 5071V	PRODUCTION TEST RANGE REQUIREMENTS FOR THE RANGE HAVE BEEN ESTABLISHED. DUE TO LACK OF QUALIFIED RANGE DESIGN PERSONNEL, YPG PLANS TO CONTRACT FOR THE RANGE DESIGN.				DEC 78	SEP 79
0 77 5071W	EVALUATION OF AMMUNITION CONDITIONING ENVIRONMENTAL CHAMBERS TEMPERATURE GRADIENTS HAVE BEEN MEASURED ACROSS 16 OF 33 CHAMBERS AT YPG.				DEC 78	SEP 79
0 77 5071Y	APPLICATION OF SIMULATION TECHNOLOGY AN INTERIM REPORT WAS RECEIVED BY TECOM 28 DEC 78. THE REPORT RECOMMENDED THAT ADDITIONAL RESEARCH BE CONDUCTED TO SOLVE AIR SURVIVABILITY STOCHASTIC MODELLING.				DEC 78	SEP 79
0 77 5071Z	INSTRUCTIONAL MATERIALS ADEQUACY GUIDE + EVALUATION SYSTEM THE SYSTEM HAS BEEN DEVELOPED. THE DESIGN HAS BEEN VALIDATED AND IS BEING DOCUMENTED.				DEC 78	SEP 79
0 78 5071	IMPROVEMENT OF PRODUCTION TEST METHODOLOGY SEE INDIVIDUAL SUBTASK BELOW FOR STATUS.	735.0	53.2	291.0	DEC 79	DEC 79
0 78 5071A	ACCEPTANCE TEST PROCEDURES TASK WAS COMPLETED. NINETEEN ATPS RELATING TO ARTILLERY AND ARMOR MATERIEL WERE PREPARED AND COORDINATED WITH OTHER AGENCIES.					DEC 79

S U M M A R Y P R O J E C T S T A T U S R E P O R T
2ND SEMIANNUAL SUBMISSION CY 78 RCS DRGNT-301

PROJ NO.	TITLE + STATUS	AUTOM- RIZED (\$000)	CONTRACT VALUES (\$000)	EXPENDED LABOR AND MATERIAL (\$000)	ORIGINAL PROJECTED COMPLETE DATE	PRESENT PROJECTED COMPLETE DATE
0 78 50718	GENAEC AND CONVENTIONAL INSTRUMENTATION DATA CORRELATION AN INVESTIGATION IS UNDERWAY TO DEFINE THE DATA REQ. OF MIL-STD-705 AND MTD GENERATOR TEST PROCEDURES. THE RESULTS WILL BE USED TO EVALUATE THE EXISTING SOFTWARE FOR COMPATIBILITY.					DFC 79
0 78 5071C	ELECTROSTATIC GENERATION AND PRECIPITATION A STATIC DETECTOR HEAD HAS BEEN ACQUIRED AND INTERFACED TO THE ELECTROMETER. INITIAL TESTS HAVE BEEN MADE TO DETERMINE THE FEASIBILITY OF USING THE FARADAY CAGE IN CONJUNCTION WITH THE ELECTROMETER-STATIC CHARGE/POTENTIAL ON IRREGULARLY SHAPED OBJECT					DEC 79
0 78 5071D	SOLID STATE SHEAR CAMERA THE PRELIMINARY DESIGN OF A SOLID STATE SHEAR CAMERA HAS BEEN COMPLETED. IT WAS DETERMINED THAT ARRAYS CURRENTLY AVAILABLE COMMERCIALY DO NOT SATISFY THE SPEED REQ. FOR SHEAR CAMERA APPLICATIONS. TASK HAS BEEN SUSPENDED DUE TO MANPOWER SHORTAGES.					DEC 79
0 78 5071E	GUN AIR DEFENSE SYSTEM LASER TECHNIQUES TASK HAS BEEN SUSPENDED AND FUNDS WITHDRAWN DUE TO MANPOWER SHORTAGES. THE PRELIMINARY STUDY HAD INDICATED THAT SIGNIFICANT IMPROVEMENTS COULD BE ACHIEVED WITH A NEW TARGET TRACKING SYSTEM.					DEC 79
0 78 5071F	PROJECTILE EDDY CURRENT INSPECTION AN EDDY CURRENT INSPECTION INSTRUMENT HAS BEEN DELIVERED AND A SCANNING MECHANISM HAS BEEN ACQUIRED FOR PRELIMINARY EVALUATION AND DEVELOPMENT OF AN INSPECTION PROCEDURE FOR DETECTING CRACKS IN NOSE AND BODY OF PROJECTILES.					DEC 79
0 78 5071G	IN-BORE RADIOGRAPHY TECHNIQUE APPLICATION THE FEASIBILITY OF A X-RAY TRIGGER HAS BEEN DEMONSTRATED. DETERMINATION OF FILM PROCESSING CHEMISTRY PARAMETERS IS UNDERWAY UTILIZING FILM DEVELOPING QUALITY CONTROL KITS.					DEC 79
0 78 5071H	MILITARY VEHICLE ROLL OVER TESTS A CONTRACT WAS AWARDED 15 DEC 1978 TO INVESTIGATE ROLL-OVER ACCIDENT AND FIELD STABILITY TEST METHODS EMPLOYED BY PRIVATE INDUSTRY AND OTHER GOVERNMENT AGENCIES. THE CONTRACTOR WILL RECOMMEND A FIELD SYSTEM FOR INSTALLATION AT APG.					DEC 79
0 78 5071I	MULTI-FUEL SPACE HEATERS CAPACITY TESTING TWO PROCEDURES HAVE BEEN SELECTED FOR DETAILED ANALYSIS AND INVESTIGATION FOR POSSIBLE INCORPORATION INTO APG TEST PROGRAMS.					DEC 79
0 78 5071J	TRANSDUCER VELOCITY MEASUREMENT WORK WAS SUSPENDED DUE TO THE TRANSFER OF THE PRINCIPAL INVESTIGATOR. THE TASK WILL BE REINITIATED WHEN QUALIFIED TECHNICAL PERSONNEL ARE AVAILABLE.					DEC 79

MANUFACTURING METHODS AND TECHNOLOGY PROGRAM
 S U B M A R Y P R O J E C T S T A T U S R E P O R T
 2ND SEMI-ANNUAL SUBMISSION CY 78 MCS DRCMT-301

PROJ NO.	TITLE + STATUS	AUTHORIZED (\$000)	CONTRACT VALUES (\$000)	EXPANDED LABOR AND MATERIAL (\$000)	ORIGINAL PROJECTED COMPLETE DATE	PRESENT PROJECTED COMPLETE DATE
0 78 5071K	<p>DIRT FIRE WEAPON ADVANCED MUZZLE RORE SIGHT WORK SUSPENDED DUE TO THE TRANSFER OF THE PRINCIPLE INVESTIGATOR. THE TASK WILL BE REINITIATED WHEN QUALIFIED TECHNICAL PERSONNEL ARE AVAILABLE.</p>					DEC 79
0 78 5071L	<p>MICROWAVE SKY SCREEN SUFFICIENT TECHNICAL PERSONNEL WERE NOT AVAILABLE TO ACCOMPLISH THE WORK PLAINED DURING THIS REPORTING PERIOD.</p>					DEC 79
0 78 5071M	<p>IMPROVED CRUSHER GAGES A PROPOSAL WAS RECEIVED FOR EVALUATION OF THE M11 COPPER CRUSHER GAGE WITH ESTIMATED COST AND SCHEDULE. THE PROPOSAL WAS ACCEPTED. THE EVALUATION PORTION OF THE CONTRACT HAS BEEN COMPLETED. AN INTERIM REPORT IS SCHEDULED FOR APRIL 1979.</p>					DEC 79
0 78 5071N	<p>TEST AUTOMATION DEVELOPMENT WORK HAS STARTED TO IMPROVE DATA COLLECTION AND ANALYSIS TECHNIQUES CURRENTLY USED DURING AVIONICS TESTING. OTHER AREAS TO BE INVESTIGATED ARE IMPROVED AUTOMATION OF USAEPG SURVEILLANCE RADAR FACILITIES.</p>					DEC 79
0 78 5071P	<p>TEST OPERATIONS PROCEDURES NINE TOP WERE PUBLISHED. SEVEN DRAFTS WERE FINALIZED AND FORWARDED TO TECOM FOR APPROVAL.</p>					DEC 79
0 78 5071Q	<p>AEROSOL BIOLOGICAL PARTICLE SIZE MEAS. STANDARDIZATION A DPG MICROSCOPIST WAS TRAINED AT EDGEWOOD ARSENAL TO SIZE PARTICLES. THIS TRAINING WAS CONDUCTED TO INSURE THE METHODS, TECHNIQUES, AND PROCEDURES USED BY THE TWO INSTALLATIONS ARE THE SAME.</p>					DEC 79
0 78 5071R	<p>FERMENTATION METHODOLOGY THE 200-LITER FERMENTATION FACILITY HAS BEEN REACTIVATED. APPROX. SIX 200-LITER BATCHES OF SERRATIA MARCESCENS UK6 STRAIN HAVE BEEN PRODUCED TO DETERMINE THE AEROSOL PROPERTIES, ALSO, THESE BATCHES ARE BEING USED TO TRAIN TECHNICIANS.</p>					DEC 79
0 78 5071S	<p>AVIRULENT VEE VIRUS STRAIN STANDARDIZATION THE MATERIAL AND EQUIP. FOR THIS PROJECT HAS BEEN ACQUIRED. PRELIMINARY WORK HAS BEEN COMPLETED. THIS WORK HAS PRIMARY CONSISTED OF CHICK EMBRYO AND A CONTINUOUS LINE OF MONKEY KIDNEY (VERO) CELLS HAVE BEEN CULTIVATED IN THE LABORATORY.</p>					DEC 79
0 78 5071T	<p>TANK MAIN WEAPON FIRING INHIBITOR AN OPTICAL INHIBITOR SYSTEM USING DETECTION OF CODED ENERGY WAS DESIGNED, CONSTRUCTED AND TESTED. THIS SYSTEM SHOWED PROMISING RESULTS FOR RANGES UP TO 1000 METERS.</p>					DEC 79

REQUEST FOR QUOTATIONS FOR THE PURCHASE OF
 SUPPLIES, MATERIALS, AND TECHNOLOGY PROGRAM
 S U M M A R Y P R O J E C T S T A T U S R E P O R T
 2ND SEMI-ANNUAL SUBMISSION CY 78 RCB DRCHT-301

PROJ NO.	TITLE + STATUS	AUTHORIZED	CONTRACT VALUES (\$000)	EXPENDED LABOR AND MATERIAL (\$000)	ORIGINAL PROJECTED COMPLETE DATE	PRESENT PROJECTED COMPLETE DATE
0 79 5071	TECOM TEST METHODOLOGY ENGINEERING MEASURES THIS PROJECT WAS JUST FUNDED, NO STATUS REPORT WAS REQUIRED.		861.0			

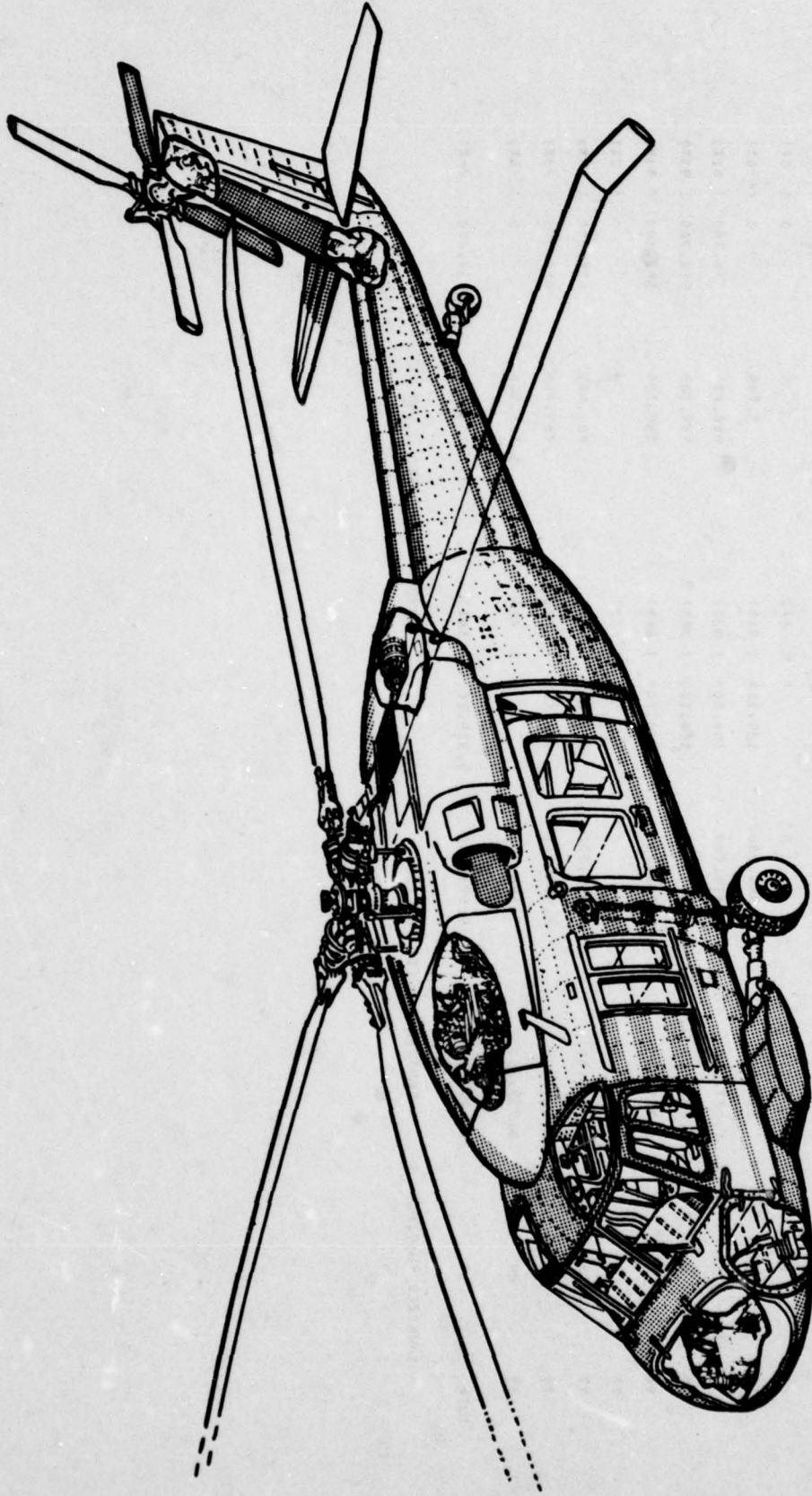

**AVIATION R&D COMMAND
(AVRADCOM)**

A V I A T I O N R + D C O M M A N D
CURRENT FUNDING STATUS, 2ND CY78

FISCAL YEAR	NO. OF PROJECTS	AUTHORIZED FUNDS (\$)	* CONTRACT FUNDS ALLOCATED (\$)	* CONTRACT FUNDS EXPENDED (\$)	* INHOUSE FUNDS ALLOCATED (\$)	* INHOUSE FUNDS EXPENDED (\$)
71	1	2,276,000	2,206,200	2,200,800 (98%)	69,800	69,000 (98%)
72	0	0	0	0 (0%)	0	0 (0%)
73	1	357,900	354,200	325,300 (91%)	3,700	0 (0%)
74	3	1,027,000	418,800	346,800 (82%)	408,200	376,700 (61%)
75	8	1,624,000	1,074,900	814,100 (75%)	549,100	514,700 (93%)
76	6	1,951,000	1,242,700	820,700 (66%)	708,300	382,100 (53%)
77	0	0	0	0 (0%)	0	0 (0%)
77	13	6,890,100	4,985,700	710,600 (14%)	1,904,400	678,200 (35%)
78	19	3,729,000	1,965,200	160,800 (8%)	1,763,800	413,500 (23%)
79	24	6,989,700	3,446,200	0 (0%)	3,543,500	0 (0%)
TOTAL	77	24,844,700	15,693,900	5,379,100 (34%)	9,150,800	2,434,200 (26%)

AUTHORIZED FUNDING CONTRACT ALLOCATED 63%

INHOUSE ALLOCATED 36%

MANUFACTURING METHODS AND TECHNOLOGY PROGRAM
 J U M M A R Y P R O J E C T S T A T U S R E P O R T
 2ND SEMI-ANNUAL SUBMISSION CY 76 RCS DRCMT-301

PROJ NO.	TITLE + STATUS	AUTHO- RIZED (\$000)	CONTRACT VALUES (\$000)	EXPENDED LABOR AND MATERIAL (\$000)	ORIGINAL PROJECTED COMPLETE DATE	PRESENT PROJECTED COMPLETE DATE
1 71 6050	AUTOMATED TAPE LAYOUT SYSTEM (ATLAS) ATTEMPTS TO CLOSE OUT THIS PROJECT ARE CONTINUING; HOWEVER, THE CONTRACTOR HAS NOT AS YET MADE A COMMITMENT ON WHEN THE REQUIRED ACTION WILL BE COMPLETED.	2,276.0	2,206.2	69.0	DEC 72	JUN 79
1 73 6673	MM+T PRECISION FORGING OF SPIRAL REVEL GEARS A FINAL AUDIT IS ON-GOING TO CLOSE OUT CONTRACT, ALL CONTRACTOR REPORTS HAVE BEEN RECEIVED.	357.9	354.2		SEP 74	JUL 79
1 78 7036	ISOTHERMAL ROLL-FORGING COMPRESSOR BLADE MOST OF THE EFFORT DURING THIS REPORTING PERIOD HAS GONE INTO THE ROUGH AND FINISH ROLL FORGING STEPS.	300.0	125.0	44.0	JUN 79	JUL 79
1 79 7036	ISOTHERMAL ROLL-FORGING COMPRESSOR BLADES THIS PROJECT HAS JUST BEEN FUNDED.	275.0				
1 76 7042	MM+T MICROWAVE CURE OF COMPOSITE ROTOR BLADE SPARS CURE OPTIMIZATION RUNS HAVE SHOWN THAT THE INTERIOR OF THE COMPONENT CURES MORE RAPIDLY THAN THE EXTERIOR. A CONTRACT TO DETERMINE THE PROCESSING CONDITIONS IN A 100 MHZ 20 KW RF OVEN IS BEING PLACED. THE VANDERHILT DRAFT FINAL RPT IS COMPLETED.	250.0	50.0	110.5	FEB 77	DEC 79
1 77 7046	PRECISION CAST TITANIUM COMPRESSOR CASING ALL TECHNICAL WORK HAS BEEN COMPLETED.	206.5	90.0	27.5	SEP 78	MAR 79
1 75 7052	FEAS OF ULTRASONIC ASSISTED FORMATION OF TITANIUM NOSE CAP ***** DELTINQUENT STATUS REPORT *****	202.0	164.0	38.0	JUN 76	JUN 78
1 77 7052	FEAS OF ULTRASONIC ASSISTED FORMATION OF TITANIUM NOSE CAP THE PROPOSAL WAS RECEIVED FROM SONOROND CORP. THE CONTRACT WAS AWARDED TO ESTABLISH PROCESSING PARAMETERS TO FORM NOSE CAPS TO THE AAM CONFIGURATION AND TO DEVELOP PROCESS EQUIPMENT.	520.0	430.0	66.0	SEP 79	MAR 80
1 76 7054	MM+T DIFFUSION BOND TITANIUM SPAR FABRICATION. DRAFT OF FINAL REPORT HAS BEEN SUBMITTED FOR REVIEW.	315.0	70.0	23.0	JUN 77	SEP 78
1 78 7055	ULTRASONIC WELDING OF HELICOPTOR FUSELAGE STRUCTURES NO WORK HAS BEEN PERFORMED.	441.0			JAN 79	DEC 80
1 75 7070	CAST COMPRESSOR COMPONENTS ENGINE QUALIFICATION TEST IS BEING CONDUCTED. CAST ROTOR HAS UNDERGONE 100 HRS. TESTING.	195.0	171.3	23.6	OCT 77	JUN 79
1 76 7079	MM+T BRAIDING OF REINFORCED PLASTIC STRUCTURAL COMPONENT THE CONTRACT WAS AWARDED. THE SPAR SELECTION PHASE OF THE PROJECT HAS BEEN INITIATED.	156.0	136.7	16.4	JAN 78	APR 79

MANUFACTURING METHODS AND TECHNOLOGY PROGRAM
 S U N M A R Y P H O J E C T S T A T U S R E P O R T
 2ND SEMIANNUAL SUBMISSION, CY 78 MCS ORCNT-301

PROJ NO.	TITLE + STATUS	AUTHORIZED (\$000)	CONTRACT VALUES (\$000)	EXPANDED LABOR AND MATERIAL (\$000)	ORIGINAL PROJECTED COMPLETE DATE	PRESENT PROJECTED COMPLETE DATE
1 78 7086	BARADABLE SEALS FOR COMPRESSOR BLADE TIP APPLICATIONS THE CONTRACT WAS AWARDED TO PRATT AND WHITNEY, FLORIDA, PLANS FOR IMPLEMENTATION AND DEMONSTRATION HAVE BEEN FORMULATED, AND ARMY HARDWARE HAS BEEN PROVIDED FOR SEAL ATTACHMENT INVESTIGATIONS. PROCUREMENT OF RAW MATERIALS IS IN PROCESS.	91.0	77.0	5.0	JUN 79	JUN 79
1 79 7086	ARRADABLE SEALS FOR COMPRESSOR BLADE TIP APPLICATION FUNDS ARE BEING TRANSFERRED TO AMHRC.	100.0	90.0			
1 78 7091	PROCESSING AIRCRAFT COMPONENTS USING PULTRUDED MATERIALS AN RFO HAS BEEN ISSUED. RESPONSES ARE DUE 19 JAN. POLYESTER RESIN WITH E-GLASS AND S-GLASS REINFORCEMENT HAVE BEEN SUCCESSFULLY PULTRUDED. AN EPOXY RESIN FIBERGLASS SYSTEM AND A NEVLAR BRAID POLYESTER SYSTEM WERE PULTRUDED WITH MODERATE SUCCESS.	320.0	150.0	101.7	SEP 80	AUG 80
1 76 7103	IMPROVED MFG-RISK/IMPELLER TURBINE ENGINE COMPRESSOR PARTS ***** DELINQUENT STATUS REPORT *****	435.0	417.7	17.3	DEC 77	JUN 78
1 77 7103	IMPROVED MFG-RISK/IMPELLER TURBINE ENGINE COMPRESSOR PARTS ***** DELINQUENT STATUS REPORT *****	305.0	304.3	1.0	NOV 78	MAR 79
1 77 7104	T700 TURBINE ENGINE NOZZLE MANUFACTURING PROCESS SEE PROJECT 1 78 7104.	33.4	33.2	3.9	JUN 79	NOV 79
1 78 7104	T700 TURBINE ENGINE NOZZLE MANUFACTURING PROCESS INSUFFICIENT DATA AVAILABLE IN 31 DEC 78 STATUS REPORT. WORK ACCOMPLISHED CANNOT BE SUMMARIZED. ONE CONTRACT TO GE WAS LET UTILIZING FUNDS FROM PROJECTS 1 77 7104, 1 78 7104, 1 77 7144, AND 1 78 7144.	25.0	23.7	8.3	MAR 78	NOV 79
1 77 7108	MANUFACTURING TECHNIQUES FOR TRANSMISSION SHAFT SEALS CONTRACT WORK BEGAN IN AUGUST 1978. THE SEAL AND TEST HEAD DESIGNS ARE COMPLETED, AND FABRICATION HAS STARTED.	135.0	121.5	13.5	AUG 79	OCT 79
1 77 7112	COMPOSITE IMPROVED MAIN ROTOR BLADES ***** DELINQUENT STATUS REPORT *****	4,146.0	3,450.7	160.0	SEP 78	SEP 78
1 79 7113	COMPOSITE FUSELAGE MANUFACTURING TECHNOLOGY MEETINGS WITH THE PMO HAVE RESULTED IN THEIR SUPPORT OF THE PROGRAM. THE SOLE SOURCE CONTRACTOR, HOWEVER, SEES THE PROJECT COSTING \$2M RATHER THAN \$2M WHICH IS PLANNED. IF THE CONTRACTOR INSISTS ON THE HIGHER COST, THE PMO WILL NOT SUPPORT THE PROJ.	250.0	200.0			SEP 81
1 77 7114	MFG TECHNIQUES FOR INFRARED SUPPRESSION AIRCRAFT COMPONENTS CONTRACT AWARDED TO ASTRONICS COMPANY TO ESTABLISH EFFICIENT MFG METHOD FOR PREPARATION OF LOUVERS REQUIRED IN PROD OF FILM-COOLED IR SUPPRESSOR SYSTEMS FOR ARMY AIRCRAFT.	510.0	95.0	54.0	APR 78	NOV 79

S U M M A R Y P R O J E C T S T A T U S R E P O R T
2ND SEMIANNUAL SUBMISSION CY 78 RCS DRCHT-301

PROJ NO.	TITLE + STATUS	AUTHORIZED (\$000)	CONTRACT VALUES (\$000)	EXPENDED LABOR AND MATERIAL (\$000)	ORIGINAL PROJECT COMPLETE DATE	PRESENT PROJECT COMPLETE DATE
1 77 7119	NON-DESTRUCTIVE EVALUATION TECH FOR COMPOSITE STRUCTURES 4M-FIG MATERIAL SAMPLES, SPAR, SKIN, ETC., WERE RECEIVED BY THE CONTRACTOR. ACOUSTIC EMISSION, FTS-TR, MPLC, AND QUANTIMET ANALYER SYS. HAVE BEEN UPDATED. DESIGN OF FILAMENT WOUND BOX BEAM SAMPLES HAS BEEN FINALIZED AND MATERIALS ORDERED.	475.0	62.0	230.5	SEP 80	JUN 81
1 78 7119	NON-DESTRUCTIVE EVALUATION TECH FOR COMPOSITE STRUCTURES HONEYCOMB PANELS WERE FABRICATED FROM GLASS/EPOXY, KEVLAR/EPOXY PREPRAG AND 1 INCH THICK NOMEX HONEYCOMB. TESTS WERE CONDUCTED TO DETERMINE CLEANING ON THE MECH. AND CHEM. PROPERTIES OF THESE PANELS. DELAMINATION WILL BE DETERMINED BY ULTRASONICS.	96.0	15.0	15.1	SEP 80	JUL 81
1 79 7119	NDE TECHNIQUES FOR COMPOSITE STRUCTURES NO WORK ACCOMPLISHED TO DATE.	400.0				
1 78 7121	INTEGRALLY HEATED + PRESSURIZED TOOLING F/UTTAS ROTOR BLADES AN RFD WAS ISSUED AND PROPOSALS WERE RECEIVED FROM BELL, HUGHES, AND SIKORSKY. CONTRACT AWARD IS EXPECTED BY 12 JAN 79.	230.0	210.0	7.7	JUN 79	JUN 79
1 78 7123	CONTINUOUS BALANCING OF HELICOPTOR SHAFTING THE CONTRACT FOR THIS PROJECT WAS AWARDED 25 SEPT. 1978. THE INSTRUMENTATION SELECTION AND RIG MODIFICATIONS ARE CONTINUING.	120.0	90.0		JUN 79	OCT 79
1 77 7144	T700 ENGINE NOZZLE IN-PROCESS INSPECTION PHASE I OF THE PROJECT HAS PROCEEDED IN A TIMELY TECHNICALLY COMPETENT MANNER. PHASE II HAS BEEN INITIATED UNDER MMT PROJECT NO. 1 78 7144. ONE CONTRACT TO GE WAS LET USING FUNDING FROM PROJECTS 1 77 7104, 1 78 7104, 1 77 7144, AND 1 78 7144.	66.6	59.0	8.6	APR 79	DEC 80
1 78 7144	T700 ENGINE NOZZLE IN-PROCESS INSPECTION PHASE II OF THE CONTRACT HAS PROCEED ON SCHEDULE.	67.0			NOV 79	DEC 80
1 78 7155	MFG METHODS FOR IMPROVED HIGH PERFORMANCE HELICOPTER GEARS OBTAINED BELL'S PERMISSION TO USE AN AH-1 TRANSMISSION GEAR AS A MODEL FOR THIS PROJECT. WORK ON PROCUREMENT PACKAGE IS PROCEEDING.	461.0	360.0	57.4	NOV 80	NOV 80
1 76 7156	ULTRASONICALLY ASSISTED MACHINING FOR SUPERALLOYS. SONOBOND CORP HAS AWARDED A CONTRACT TO DESIGN, FAB, TEST, AND EVALUATE ULTRASONIC EQUIP AS AN ASSIST TO MACHINING. THE PRELIMINARY DESIGN OF THE ULTRASONIC TOOL POST IS IN PROCESS.	270.0	207.1	63.9	MAY 78	DEC 79
1 76 7164	FILAMENT WINDING PRECISION RESIN IMPREGNATION SYSTEM PROCESS VARIABLES FOR IMPREGNATING GLASS, KEVLAR AND GRAPHITE FIBERS WERE EVALUATED. COMPRESSION AND TENSILE SPECIMENS WERE WOUND AND TESTED. A CONTRACT EXTENSION WAS GRANTED.	90.0	89.2		JUN 77	JUN 79

S U M M A R Y P R O J E C T S T A T U S R E P O R T
2ND SEM-ANNUAL SUBMISSION CY 78 RCS DRC-1-301

PROJ NO.	TITLE + STATUS	AUTHORIZED (\$000)	CONTRACT VALUES (\$000)	EXPENDED		PRESENT PROJECTED COMPLETE DATE
				LABOR AND MATERIAL (\$000)	ORIGINAL PROJECTED COMPLETE DATE	
1 78 7183	SEMI-AUTO COMPOSITE MFG SYS- HELICOPTER FUSELAGE STRUCTURES TECHNICAL PROPOSALS RECEIVED FROM THE CONTRACTOR WERE MORE COMPREHENSIVE THAN THE SOP CONVEYED. IT WAS REQUESTED THAT THE CONTRACTOR REDUCE THE PROPOSED WORK. CONTRACT WORK ON HIGHER PRIORITY ARMY PROJECTS (7338 AND 7340) WAS DELAYED THE REPLY.	245.0	191.0	36.0	MAR 81	OCT 79
1 79 7183	SEMI-AUTO COMPOSITE MFR SYS FOR HELICOPTER STRUCTURES FUNDS ARE BEING TRANSFERRED FROM AVRADCOM TO THE APPLIED TECHNOLOGY LABORATORY, FORT EUSTICE, VA.	100.0	85.0			
1 77 7197	FABRICATION OF INTEGRAL ROTORS BY JOINING DESIGN AND INITIAL TOOLING REQUIREMENTS HAVE BEEN COMPLETED. HARDWARE FABRICATION HAS BEEN INITIATED.	300.0	240.0	37.0	DEC 80	APR 79
1 79 7197	FABRICATION OF INTEGRAL ROTORS BY JOINING FUNDS HAVE BEEN RELEASED.	100.0				
1 78 7199	LASER HARDENING OF GEARS, BEARINGS AND SEALS LASER HEAT TREAT PARAMETERS FOR BEARING RINGS HAVE BEEN ESTABLISHED. RESULTS ARE ENCOURAGING EXCEPT FOR SOME ANOMALIES IN REPEATABILITY.	180.0	100.0	28.0	SEP 78	OCT 79
1 79 7199	SURFACE HARDENING OF GEARS, BEARINGS AND SEALS BY LASERS FUNDS HAVE BEEN RELEASED.	200.0				
1 79 7200	COMPOSITE ENGINE INLET PARTICLE SEPARATOR FUNDS ARE BEING TRANSFERRED TO THE APPLIED TECHNOLOGY LABORATORY, FORT EUSTICE, VA.	200.0	180.0			
1 79 7202	APPLICATION OF THERMOPLASTICS FUNDS ARE BEING TRANSFERRED TO APPLIED TECHNOLOGY LAB, FORT EUSTICE, VA.	225.0	202.5			
1 77 7238	PRECISION FORGED ALUMINUM POWDER METALLURGY MELD DESIGN OF THE VACUUM FORGING SYSTEM HAS BEEN COMPLETED. FABRICATION OF THE SYSTEM HAS BEEN INITIATED.	72.6	50.0	18.8	MAR 79	MAR 79
1 79 7238	PRECISION FORGED ALUMINUM POWDER MTL HELICOPTER COMP FUNDS HAVE BEEN RELEASED.	398.7				
1 78 7240	MACHINING METHODS FOR ESR 4340 STEEL F/HELICOPTERS CONTRACT NEGOTIATIONS COMPLETED AND CONTRACT SIGNED. WETCUT HAS COMPLETED THEIR LITERATURE SURVEY AND IS ORGANIZING THE DATA.	117.0	98.5	20.6	SEP 78	MAR 79
1 79 7240	MACHINING METH FOR ESR 4340 STEEL FOR HELICOPTER APPL NO WORK ACCOMPLISHED TO DATE.	75.0				

S U M M A R Y P R O J E C T S T A T U S R E P O R T
2ND SEMI-ANNUAL SUBMISSION CY 78 RCS DRCMT-301

PROJ NO.	TITLE + STATUS	AUTHORIZED (\$000)	CONTRACT VALUES (\$000)	EXPENDED LABOR AND MATERIAL (\$000)	ORIGINAL PROJECTED COMPLETE DATE	PRESFAT PROJECTED COMPLETE DATE
1 78 7241	HOT ISOSTATIC PRESSING OF TITANIUM CASTINGS AN RFO WAS FORWARDED AND A REPLAY WAS RECEIVED.	113.0		9.1	MAR 79	APR 79
1 79 7241	HOT ISOSTATIC PRESSED TITANIUM CASTINGS \$570K HAS BEEN SENT TO AMRC.	600.0	520.0			
1 79 7243	MACHINING OPERATIONS ON KEVLAR LAMINATED CONSTRUCTIONS EFFORTS ARE IN PROCESS TO PLACE THE WORK UNDER CONTRACT.	104.0	97.0			
1 77 7258	THIN WALL MANTECH FOR RPV SENSOR DUMES THE LITERATURE SEARCH AND INDUSTRY SURVEY HAVE BEEN COMPLETED. A TECHNICAL REPORT IS IN PROGRESS AND SHOULD BE AVAILABLE DURING THE NEXT REPORT PERIOD.	35.0		7.3	AUG 80	FEB 79
1 77 7281	SURVEY OF COMPOSITE MANTECH F/ARMY AIRCRAFT STRUCTURES THE INFORMATION GATHERED FROM SURVEYING ARMY AND OTHER CONTRACTORS INVOLVED IN COMPOSITE MANUFACTURING HAS ORGANIZED FOR THE FINAL REPORT.	85.0	50.0	30.1	SEP 78	JAN 79
1 78 7284	SUPERPLASTIC FORMING OF TITANIUM FOR HELICOPTER COMPONENTS CONTRACT NEGOTIATIONS ARE STILL IN PROCESS.	108.0	425.0	21.5	JUL 81	JUL 81
1 79 7284	SUPERPLASTIC FORMING/DIFFUSION BONDING OF TITANIUM NO WORK ACCOMPLISHED TO DATE.	400.0				
1 78 7285	CAST TITANIUM COMPRESSOR IMPELLERS THIS IS A JOINT AF/ARMY PROGRAM. TWO CONTRACTS HAVE BEEN AWARDED. BOTH ARE ON SCHEDULE.	135.0	100.0	29.0	JUN 78	MAR 80
1 79 7285	CAST TITANIUM COMPRESSOR IMPELLER FUNDS HAVE BEEN RELEASED.	300.0				
1 78 7286	SUPERALLOY POWDER PRODUCTION FOR TURBINE COMPONENTS CONTRACT BEING NEGOTIATED. 2 MONTH DELAY HAS BEEN CAUSED BY DIFFICULTIES ENCOUNTERED BY AUDITING POTENTIAL CONTRACTORS.	220.0		25.9	SEP 79	DEC 80
1 79 7286	HIGH QUALITY SUPERALLOY POWDER PRODUCTION FOR TURBINE COMP FUNDS JUST RELEASED.	356.0				
1 78 7287	PRODUCTION METHODS FOR MULTI-ELEMENT MODULES F/ARRAY ANTENNA ***** DELINQUENT STATUS REPORT *****	240.0		4.2	DEC 80	DEC 80
1 79 7287	PRODUCTION METHODS FOR MULTI-ELEMENT MODULES FOR ARRAY ANTEN AVRADCOM TRANSFERRED FUNDS TO THE ARMY AVIONICS R+D ACTIVITY AT FT MONMOUTH. A CONTRACTOR WILL APPLY HIGH VOLUME HYBRID MODULE TECHNIQUES TO DRIVER CIRCUITRY FOR PHASED ARRAY ANTENNAS.	275.0				

MANUFACTURING METHODS AND TECHNOLOGY PROGRAM
 SUMMARY REPORT SUBJECT STATEUS RFP #141
 2ND SEMI-ANNUAL SUBMISSION CV 74 RCS DRCT-1-301

PROJ NO.	TITLE + STATUS	AUTHORIZED (\$000)	CONTRACT VALUES (\$000)	EXPENDED LABOR AND MATERIAL (\$000)	ORIGINAL	PRESENT
					PROJECTED COMPLETE DATE	PROJECTED COMPLETE DATE
1 79 7288	OPTIMAL CURING COND. FOR PROCESS FIBER-REINFORCED COMPOSITES FUNDS ARE BEING TRANSFERRED TO AMRC.	125.0	112.5			
1 79 7291	TITANIUM POWDER METAL COMPRESSOR IMPELLER FUNDS HAVE BEEN RELEASED.	240.0				
1 79 7292	IMPROVED PROD PROC TO REDUCE COST OF TESTING MICROPROCESSOR PROJECT HAS BEEN FUNDED AT THE LEVEL REQUESTED.	260.0	180.0			
1 79 7297	PROD-INSTALL OF URETHANE EDGE GUARDS ON ROTOR BLADES FUNDS ARE BEING TRANSFERRED TO THE APPLIED TECHNOLOGY LABORATORY, FORT EUSTICE, VA.	98.0	68.2			
1 79 7315	LOW COST MANUFACTURE OF POISE GIMBAL FUNDS ARE BEING TRANSFERRED TO FORT MONMOUTH.	267.0	202.0			
1 79 7338	COMPOSITE TAIL SECTION EFFORTS ARE IN PROCESS TO PLACE THE WORK UNDER CONTRACT.	900.0	850.0		JUN 80	JUN 80
1 79 7340	COMPOSITE MAIN ROTUM BLADE EFFORTS ARE IN PROCESS TO PLACE THE WORK UNDER CONTRACT.	739.0	639.0			
1 78 7348	LTWT COMPOSITE FASTENING SYS FOR COMPOSITE HELICOPTER COMPTS ACTION HAS BEEN TAKEN TO INCORPORATE THIS PROJECT INTO THE AIR FORCE "MANUFACTURING TECHNOLOGY FOR LOW COST COMPOSITE FASTENERS" AS A PHASE III EFFORT. THE TOTAL PROJECT FUNDING WAS RIFRED TO AFML/TLN AND THE AF CONTRACT WAS MODIFIED FOR THIS PROJECT	216.0			JUN 80	JUN 80
1 74 8008	BROADGOODS LAY UP SYSTEM (CAM RELATED) CONTRACTS AWARDED AND COMPLETED FOR MODIFICATION OF BROADGOODS MACHINE AT AMRC. THIS EQUIPMENT IS BEING DEBUSED/PROVED-OUT AND MATERIAL IS BEING FABRICATED AT AMRC. MODIFICATION CONSISTED OF INTEGRATION OF INDUSTRIAL PROCESS CONTROLLER + MOTOR SYS	700.0	241.8	226.7	MAY 75	AUG 79
1 75 8017	EROSION RESISTANT LEADING EDGE FOR HELICOP Rotor BLADES TESTS ON BORDID TI AND STAINLESS STEEL SPECIMENS WERE COMPLETED BY HUGHES PHYSICAL TESTING OF BORDID SPECIMENS WILL BE CONDUCTED BY SIKORSKY. THE PORTION OF THE PROGRAM TO BE CONDUCTED BY BELL IS IN THE FINAL STAGES OF CONTRACT NEGOTIATION.	268.0	217.0	45.4	MAY 74	SEP 79
1 74 8035	PROD OF TRANSPARENT FORMS OF POLYOLEFIN FOR LTWT ARMOR APPLN 15 FILMS AND LAMINATES WERE EVALUATED. HERCULES EK500 IMIL POLYPROPYLENE HOMOPOLYMER FILM OF BALANCED ORIENTATION WAS CHOSEN. SELECTION MADE ON BASIS OF HIGHEST LIGHT TRANSMISSION AND LOWEST HAZE IN THE LAMINATE. THIS WAS ORDERED AND DLUY EXPECTED FEB	125.0	97.0	28.0	JUN 75	SEP 79

MANUFACTURING METHODS AND TECHNOLOGY PROGRAM
SUMMARY PROJECT STATUS REPORT
2ND SEMI-ANNUAL SUBMISSION CY 78 RCS DRCHT-301

PROJ NO.	TITLE + STATUS	AUTHORIZED VALUES (8000)	CONTRACT VALUES (8000)	EXPENDED LABOR AND MATERIAL (8000)	ORIGINAL PROJECTED COMPLETE DATE	PRESENT PROJECTED COMPLETE DATE
1 75 8035	PROD OF TRANSPARENT FORMS OF POLYOLEFIN FOR LWMT ARMOR APPLN THIS IS FOLLOW-ON PROJ TO 1 74 8035. NO FURTHER IN-HOUSE WORK FROM LAST PERIOD. CONTRACT WORK UNDER THIS PROJECT WILL NOT BE REPORTED UNTIL FUNDS FOR CONTRACT WORK UNDER PROJECT 1 74 8035 ARE DEPLETED.	114.0	31.0	83.0	SEP 76	MAY 80
1 76 8045	FIBER-REINFORCE PLASTIC HELICOPTER TAIL ROTOR ASSEMBLY COMPLETION OF THE FINAL REPORT BY THE CONTRACTOR HAS BEEN DELAYED. COMPLETION IS NOW PROJECTED FOR 28 FEB 79.	285.0	238.0	47.0	FEB 78	AUG 79
74 8091	ADVANCED ADHESIVES FOR TRANSPARENT ARMOR REASON FOR SLIPPAGE WAS LONG DELAY IN PROCURING WINDSHIELD DRAWINGS NEEDED FOR PROPER REGRS ON WINDSHIELD CONTRACT. FINAL CONTRACT AWARDED ON 28 MAR 78 BUT 3-MON SLIPPAGE CAUSED BY PROBLEMS OF AIR INCLUSION AND POOR ADHESIVE BONDING. ALLEV BY PRIMER	202.0	80.0	122.0	JUN 75	MAR 79
1 75 8120	IMPRVD HCPTB SKIN MATERIAL BY CNTRLD SOLIDIFICATION + TMT SPECIMEN PARTS WERE FABRICATED AND INSPECTED. TEST FIXTURES WERE FABRICATED, ASSEMBLED AND INSTALLED ON TESTING MACHINES. DYNAMIC TESTING OF THE SPECIMENS WAS INITIATED.	230.0	175.0	46.3	JUN 76	MAY 79
1 75 8129	COLUMBIUM ALLOY TURBINE ENGINE COMPONENTS CONTRACT MODIFICATION WAS COMPLETED. HOT CORROSION TESTING WAS COMPLETED.	250.0	169.4	80.6	APR 76	APR 79
1 75 8136	HIGH STRENGTH FLEXIBLE CARGO RESTRAINT DEVICES ABRASION RESISTANCE TESTING OF TWO KEVLAR WEBBINGS HAS BEEN COMPLETED. ONE KEVLAR TYPE QUALIFIED FOR TYPE XIII NYLON WEBBING APPLICATIONS. THE OTHER TYPE QUALIFIED FOR TYPE XXVI NYLON WEBBING. AN EXTENSION OF ONE YEAR IS NECESSARY FOR COMPLETION.	150.0	63.2	66.6	AUG 75	SEP 80
1 75 8148	PROCESSING ADVANCED GEAR MATERIALS CONTRACTOR IS HAVING DIFFICULTY IN VACUUM CARBORIZING A SATISFACTORY PIN.	195.0	84.0	111.0	OCT 76	MAR 79
1 76 8148	PROCESSING ADVANCED GEAR MATERIALS ALL TESTS ARE UNDERWAY.	150.0	34.0	104.0	DEC 78	SEP 79

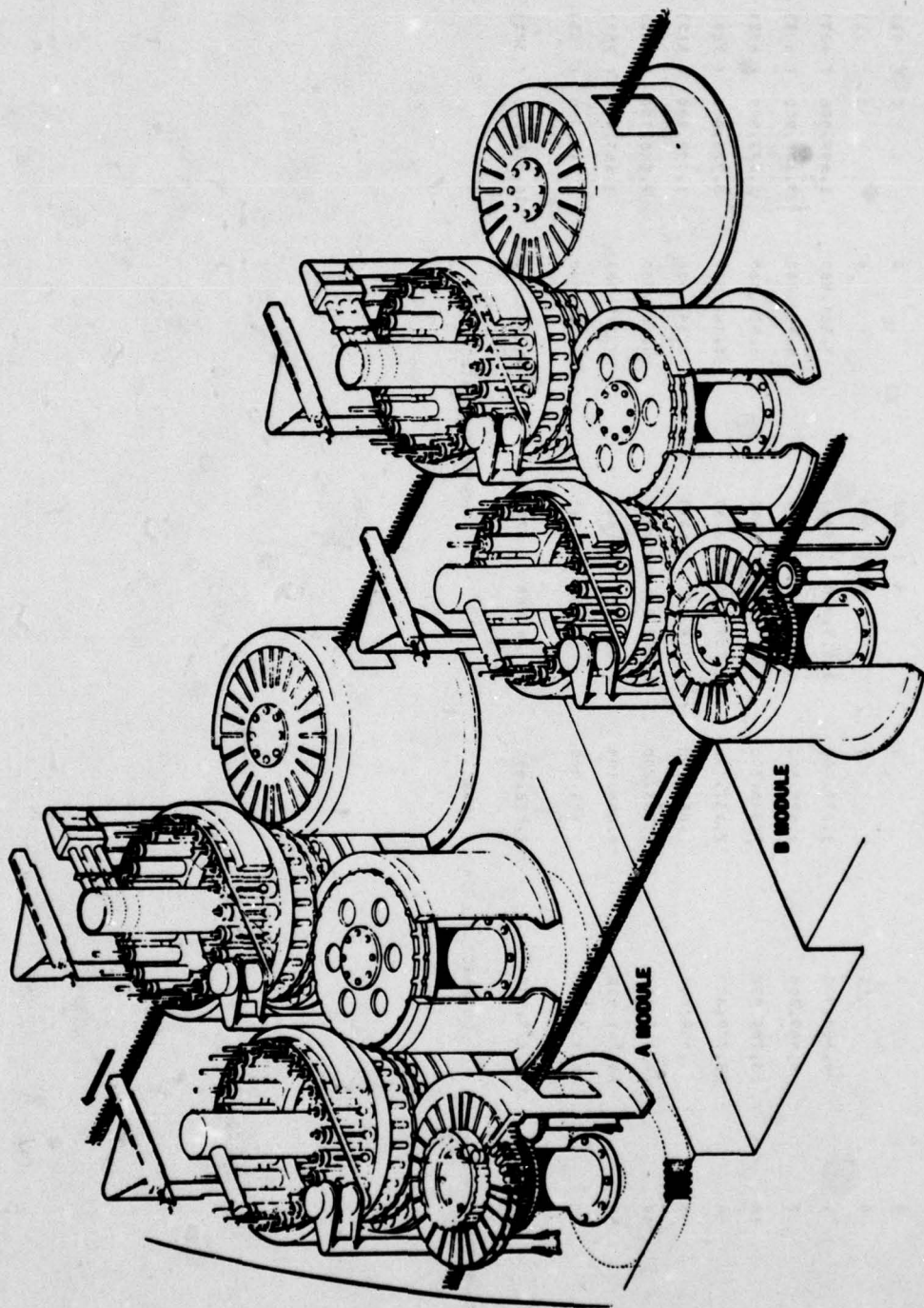

**ARMAMENT R&D COMMAND
ARMAMENT MATERIEL READINESS COMMAND
(ARRADCOM, ARRCOM)
(AMMUNITION)**

A R R C O M - A R R A D C O M (AMMUNITION)
CURRENT FUNDING STATUS, 2ND CY79

FISCAL YEAR	NO. OF PROJECTS	AUTHORIZED FUNDS (\$)	* CONTRACT FUNDS ALLOCATED (\$)	* CONTRACT FUNDS EXPENDED (\$)	* INHOUSE FUNDS ALLOCATED (\$)	* INHOUSE FUNDS EXPENDED (\$)
70	1	1,252,500	1,217,500	1,216,400 (99%)	35,000	35,000 (100%)
71	0	0	0	0 (0%)	0	0 (0%)
72	0	0	0	0 (0%)	0	0 (0%)
73	1	6,608,500	3,077,000	3,075,900 (99%)	3,531,500	1,499,000 (42%)
74	7	9,509,800	4,675,600	4,416,900 (94%)	4,834,200	3,104,900 (64%)
75	10	13,780,800	7,246,700	6,209,200 (85%)	6,538,100	4,423,500 (67%)
76	35	23,779,600	12,037,100	10,569,500 (88%)	11,342,500	8,726,000 (76%)
77	11	4,056,000	2,665,400	1,716,900 (64%)	1,392,600	1,198,000 (86%)
77	00	24,019,000	13,553,200	6,597,800 (48%)	10,465,800	7,548,700 (72%)
78	55	26,741,600	12,466,100	2,283,000 (18%)	14,275,500	3,663,900 (25%)
79	47	24,930,000	484,000	35,000 (7%)	24,446,000	15,000 (0%)
TOTAL	211	134,679,800	57,822,600	36,124,600 (62%)	76,957,200	30,216,000 (39%)

AUTHORIZED FUNDING CONTRACT ALLOCATED 43% INHOUSE ALLOCATED 57%

S U M M A R Y P R O J E C T S T A T U S K E P O R T
 2ND SEMI-ANNUAL SUBMISSION CY 78 RCS URC-T-301

PROJ NO.	TITLE + STATUS	AUTHORIZED (\$000)	CONTRACT VALUES (\$000)	EXPENDED LABOR AND MATERIAL (\$000)	ORIGINAL PROJECTED COMPLETE DATE	PRESENT PROJECTED COMPLETE DATE
5 77 1264	ADV TECH FOR SUPPRESSIVE SHIELD OF HAZARDOUS PROD + SUP UP UNDER OPERATIONAL APPLICATIONS. TASK 1 TO MODIFY GROUP 3 SHIELD IS COMPLETE. TASK 2, THE BASIC DESIGN FOR THE GROUP 1 SHIELD WAS PUT INTO A TECH DATA PACKAGE. DRAWINGS ARE BEING REVIEWED BY ARAADCOM PRIOR TO SUBMISSION FOR SAFETY CONCURRENCE.	100.0	99.0	99.0	JUN 77	FEB 78
5 76 1264	ADV TECHNOL FOR SUPPRESSIVE SHIELD OF HAZARD PROD-SUP OPER ALL TASKS ARE COMPLETE UNDER APPLIED TECHNOLOGY, SUPPORT ENGINEERING, OPERATIONAL APPLICATION, AND HANDBOOK. TS IN THE PROPER SIZE AND THICKNESS.	1,450.0	169.9	1,276.4	DEC 76	FFB 78
5 75 1284	IMPROVEMENT + MOD OF INSP AIDS F/DEF + PROT ITEMS WORK ON THE PROTOTYPE DRAWINGS AND CONSTRUCTION OF THE PROTOTYPE MODEL CONTINUED. PROBLEMS IN OBTAINING ELECTRONIC EQUIPMENT WAS DELAYED THE COMPLETION OF THE CONTRACT. THE CONTRACT IS EXPECTED TO BE COMPLETE 31 JAN 1979.	424.0	300.0	79.0	JUN 77	JAN 79
5 77 1295	MODERNIZATION OF CHARCOAL FILTER TEST EQUIPMENT THE CONTRACT FOR THIS PROJECT WAS AWARDED AUG 78. THE EQUIPMENT DESIGN STUDY WAS INITIATED. THE TEST EQUIPMENT PRELIMINARY DESIGN IS BASED ON A RECIRCULATIVE SYSTEM. THE LAYOUT WORK FOR THE FACILITY TO HOUSE THE TEST EQUIPMENT IS UNDERWAY.	245.0	125.0	28.0	AUG 78	DEC 79
5 79 1295	MODERNIZATION OF CHARCOAL FILTER TEST EQUIPMENT THIS PROJECT WAS JUST FUNDED. NO STATUS REPORT WAS REQUIRED.	460.0				
8 78 1296	MT FOR CR FILTERS SP2 DIRECT DISPERSION FILLING WAS SUCCESSFULLY COMPLETED WITH TESTING OF A C-17 FILTER CELLS. SP3 ACQUISITION OF HARDWARE WAS INITIATED. SP4 MOISTURE ADSORPTION BY CHARCOAL COMPLETED. SP5 ALL CHARCOAL IMPREGNATION TESTS WERE COMPLETED.	650.0	210.0	298.0	MAR 79	SEP 79
5 79 1296	MT FOR CR FILTERS THIS PROJECT WAS JUST FUNDED. NO STATUS REPORT WAS REQUIRED.	400.0				
5 76 1311	MMAT-229 REFIL KIT COMPONENT-CHEMICAL AGENT ALARM DELIVERY OF FILTER AND CAPSULE ASSEMBLY MACHINES HAVE SLIPPED TO JAN 79. THE BUILDING, DRAWINGS AND OPERATION PLANS HAVE BEEN PREPARED FOR THE PREPRODUCTION RUN WITH FAM AND CAM. TESTING OF THE IMPREGNATION SYSTEM WAS COMPLETED.	570.0	177.0	334.0	DEC 77	JUN 79
5 77 1312	MMAT FOR PAPER, CHEMICAL AGENT DETECTOR HA MUTAGENICITY TESTS, WHICH HAVE DELAYED THIS PROJECT, SHOW POTENTIAL MUTAGENIC PROPERTIES FOR ONE OF THE THREE DYES. DIE RETENTION TESTS HAVE BEEN INITIATED WITH THE OTHER DYES. TESTS WITH 6 ADDITIONAL RETENTION AIDS ARE PLANNED.	118.0		53.0	MAR 78	OCT 79

MANUFACTURING METHODS AND TECHNOLOGY PROGRAM
 SUMMARY PROJECT STATUS REPORT
 2ND SEMIANNUAL SUBMISSION CY 78 RCS DRCMT-301

PROJ NO.	TITLE + STATUS	AUTHORIZED (\$000)	CONTRACT VALUES (\$000)	EXPENDED LABOUR AND MATERIAL (\$000)	ORIGINAL PROJECTED COMPLETE DATE	PRESENT PROJECTED COMPLETE DATE
5 77 1320	PILOT STATIONS FOR FILLING + CLOSING IMPROVED MP MUNITION MANUFACTURING TECH INC HAS COMPLETED ASSEMBLY OF INERTIA WELDER. FINAL DESIGN OF TAPE AND MARK MACHINE APPROVED PARTS AND COMPONENTS HAVE BEEN PURCHASED. CONTRACT FOR DRILL AND PIN MACHINE HAS BEEN TERMINATED DUE TO CONTRACTOR GOING OUT OF BUSINESS.	374.0	248.0	103.0	JUL 78	JUN 79
5 78 1320	PILOT LINE FOR IMPROVEMENT OF MP MUNITIONS CONTRACT FOR MACHINE TO TORQUE WARHEAD TO ROCKET MOTOR WAS AWARDED TO METRO MACHINE ENG INC. DESIGN CONCEPT HAS BEEN APPROVED. FABRICATION OF TOOLING FOR MP DRY FILL WAS CONTINUED.	375.0	47.0	49.0	SEPT 79	JUN 79
5 77 1327	IMPROVEMENT AND MODERNIZATION OF GAS MASK LEAKAGE TESTING M91 AND M17A MASKS WERE SENT TO SRI FOR USE IN PREPARING TEST HEAD FIXTURES. PROBLEMS WERE ENCOUNTERED WITH HNU SYSTEMS PI-101 DETECTORS. TESTS WITH THE PHOENIX PRECISION SG-20 AFROSOL GENERATOR AND J4-7000 PHOTOMETER WERE HIGHLY SUCCESSFUL.	305.0	193.0	51.7	MAR 79	MAR 79
6 78 1335	MEG TECH FOR NEW PROTECTIVE MASK NO ADDITIONAL WORK OVER THE LAST PERIOD WAS REPORTED, EVEN THOUGH COVER STOCK WAS SPENT.	724.0		124.6	JUN 79	JUN 80
5 79 1335	MAN TECH FOR NEW PROTECTIVE MASK THIS PROJECT WAS JUST FUNDED, NO STATUS REPORT WAS REQUIRED.	629.0				
5 77 1337	ENGR STUDY F/ADAPT TRF OF UK TECH/CHR SYS W/RP/BUTYL GREN FIRING TESTS WERE CONDUCTED WITH GRENADES CTG INDUCED DEFECTS. NO DIFFERENCES WERE NOTED. A 3 HP CHOPPER WAS ACQUIRED AND EXTRUDING STUDIES RUN. GEL BLENDER WAS FABRICATED AND TESTED SUCCESSFULLY. A VISIT WAS MADE TO UK PLANT TO REVIEW PROCESS DESIGN.	354.0	62.0	247.0	JAN 79	APR 79
6 78 1339	MANUFACTURING TECHNOLOGY FOR PREPARATION OF R-1 DYE A REVIEW OF LAB WORK WAS COMPLETED AND THE PROCESS WAS BEING SCALED UP TO PILOT PLANT SIZE. OF 4 MAJOR PIECES OF EQPT IN THE PLANT, 2 HAVE BEEN RECEIVED. 2 EXISTING LABS ARE BEING PREPARED FOR INSTALLATION OF THE EQUIPMENT.	461.0	43.0	190.0	JUN 79	SEPT 79
6 78 1345	MMAT FOR BIOLOGICAL WARNING SYSTEM CONTRACT AWARDED TO INTER-MARK FOR PILOT TAPE MAKING EQMT. ULTRASONIC WELDING WAS DETERMINED AS BEST FOR SEALING NYLON TAPE CASSETTE. STERILITY PROBLEM OF REFILL KIT SAMPLERS SOLVED BY AIR JET SPRAYING ALL BOTTLES BEFORE SEALING.	480.0	234.0	101.0	JAN 80	APR 79
5 79 1345	BIOLOGICAL WARNING SYSTEM THIS PROJECT WAS JUST FUNDED, NO STATUS REPORT WAS REQUIRED.	525.0				

MANUFACTURING METHODS AND TECHNOLOGY PROGRAM
 C U M M A R Y P H O J E C T S T A T U S R E P O R T
 2ND SEMI-ANNUAL SUBMISSION CY 78 RCS DRCMT-301

PRJID NO.	TITLE + STATUS	AUTHORIZED (\$000)	CONTRACT VALUES (\$000)	EXPENDED LABOR AND MATERIAL (\$000)	ORIGINAL PROJECTED COMPLETE DATE	PRESENT PROJECTED COMPLETE DATE
5 79 1347	ADVANCED TECH FOR MANUFACTURE OF RED PHOSPHORUS THIS PROJECT WAS JUST FUNDED. NO STATUS REPORT WAS REQUIRED.	526.0				
5 78 1353	SMOKE MIX PROCESS (GLATT) ***** DELINQUENT STATUS REPORT *****	390.6				
5 79 1354	SLUDGE VOLUME REDUCTION AND DISPOSAL PROCESS STUDY THIS PROJECT WAS JUST FUNDED. NO STATUS REPORT WAS REQUIRED.	122.0				
5 79 1355	MANUFACTURING PLANT TOXIC EFFLUENT/EMISSION PRETREATMENT THIS PROJECT WAS JUST FUNDED. NO STATUS REPORT WAS REQUIRED.	104.0				
5 76 3062	PELLET THERMAL POWER SUPPLY TECHNOLOGY ***** DELINQUENT STATUS REPORT *****	150.0		76.0	JAN 78	MAY 79
5 76 3110	AUTOMATED ASSEMBLY AND TESTING OF SWITCHES ***** DELINQUENT STATUS REPORT *****	90.0	39.9	60.1	FEB 77	
5 77 3127	MINIATURE BEARINGS + SHAFT MFG FOR THE XM734 FUZE. ***** DELINQUENT STATUS REPORT *****	210.0	142.0	46.0	APR 76	AUG 78
5 77 3905	PS 127 RESERVE POWER SUPPLY MFR FOR THE XM587 FUZE ***** DELINQUENT STATUS REPORT *****	375.0	57.0	35.0	NOV 78	JUL 79
5 78 3907	MNDS COUNTER-MEMORY CIRCUIT FOR FUZES PHASE 2 PARTS WERE FABRICATED AND TESTED. DECISION WAS MADE TO USE A GLASS RATHER THAN A NITRIDE PASSIVATION COATING ON THE CHIP. NITRIDE COMPLETED SETTING UP AND IS NOW DERUDDING THE IN-HOUSE HOLDING EQPT. PH 3 WAFER FABRICATION WAS COMPLETED.	300.0	273.7	4.7	SEP 79	SEP 79
5 79 3913	MECHANICAL JOINING OF MINIATURIZED ELECTRONIC COMPONENTS MOL IS UPGRADING ITS LASER WELDER BY REPLACING THE RUBY LASER WITH A LONGER LIFE HIGHER POWER YAG LASER. MOL WILL WELD PROTOTYPE PARTS USING DIFFERENT POWER DENSITIES, SPOT SIZES AND DURATIONS TO FIND BEST PARAMETERS. WILL DEVELOP A DESIGN GUIDE.	89.0		5.0	DEC 79	DEC 79
5 77 3947	THICK FILM HYBRID CIRCUITS FOR XM507E2/XM724 FUZES HONEYWELL BUILT 700 HYBRID OSCILLATORS. 12% FAILED SHOCK TEST AND 5% RAN IMPROPERLY WHEN SUPPLY VOLTAGE ROSE FAST. RCA BUILT HYBRID INTERFACE AND FIRING CIRCUITS. UNITS HAVE NOT YET BEEN GUN TESTED. THE FY77 PROJECT SHOULD BE CLOSED OUT WITH A REPORT	150.0	120.0	30.0	SEP 79	SEP 79
5 78 3947	THICK FILM HYBRID CIRCUITS FOR XM507E2/XM724 FUZES SEE TASKS HELD.	530.0	487.0	9.0	JUL 79	JUL 79

MANUFACTURING METHODS AND TECHNOLOGY PROGRAM
 S U M M A R Y R E P O R T S T A T I S T I C S R E P O R T
 2ND SEMI-ANNUAL SUBMISSION CY 78 RCS DRCHT-301

PROJ NO.	TITLE + STATUS	AUTHORIZED (\$000)	CONTRACT VALUES (\$000)	EXPENDED LABOR AND MATERIAL (\$000)	ORIGINAL PROJECTED COMPLETE DATE	PRESENT PROJECTED COMPLETE DATE
5 78 3947A	THICK FILM HYBRID CIRCUITS-HONEYWELL HONEYWELL BUILT 700 HYBRID OSCILLATOR CIRCUITS, 12% FAILED SHOCK TEST AND 5% WERE VOLTAGE SENSITIVE. FAILURE MAY BE RELATED TO PROCESS CHANGES MADE DURING THE PHASE 3 RUN. HONEYWELL IS USING TAPE AUTOMATED ROUNDING AND DYNAMIC LASER TRIMMING.	267.0	245.4	5.0	JUL 79	JUL 79
5 78 3947B	THICK FILM HYBRID CIRCUITS-RCA RCA BUILT SAMPLE HYBRID INTERFACE AND FIRING CIRCUITS. HDL HAS NOT YET GUNFIRE TESTED THEM BECAUSE FIXTURING AND FIRING HAVE A LONG TURN-AROUND TIME. TEST SAMPLE MUST BE RETURNED TO RCA IN 30 DAYS OR IT DOES NOT COUNT AS A REJECTION.	263.0	241.6	4.0	JUL 79	JUL 79
5 79 3960	PROTOTYPE PBN EQUIP FOR PRINTED CIRCUIT BOARDS HDL SELECTED PROCESSES AND EQUIPMENT FOR MAKING PRINTED CIRCUITS IN VOLUME. HDL WILL USE HIGH VOLUME PRODUCTION EQUIPMENT TO MAKE PROTOTYPE BOARDS AS CONTRACTORS MAKE PRODUCTION BOARDS. WILL USE BY BOTH ADDITIVE AND SUBTRACTIVE PROCESSES.	405.0	292.0	10.0	DEC 79	DEC 79
5 79 3961	IMPROVED 3RD VIBRATION ACCEPTANCE TEST FOR ART FUZZES THE SYSTEM ENGINEERING DEFINITION TASK IS UNDERWAY. A MILESTONE SCHEDULE FOR THE PROJECT HAS BEEN COMPLETED.	282.0	192.0		SEP 81	SEP 81
5 74 4000	NON-ELECTRIC DETONATOR PRODUCTION FACILITIES UNSATISFACTORY ANALYSIS OF PA-130 HAS BEEN ATTRIBUTED TO LUMP FORMATION DURING MIXING. USING A LOOSE ROLLER IN THE MIXER HAS PROVEN SUCCESSFUL IN BREAKING UP LUMPS. SCALED-UP ROLLER WILL BE FURNISHED LSAAP FOR NEXT BLENDING OPERATIONS.	549.0	64.0	456.8	JUN 75	JUN 80
5 77 4000	AUTOMATED M55 DETONATOR PRODUCTION EQUIPMENT. THREE PROPOSALS FOR THE PACKOUT EQUIPMENT WERE RECEIVED AND EVALUATED. A CONTRACT WAS AWARDED FOR AN R-MU FEASIBILITY STUDY OF ULTRASONIC SEALING. S.O.W. PREPARED FOR MULTI-TUOL HAZARDS ANALYSIS.	1,000.0	417.0	438.2	FFB 80	SEP 80
5 78 4000	NON-ELECTRIC DETONATOR PRODUCTION EQUIPMENT CUP INSPECTION EQUIP IS CURRENTLY ON ORDER. CONTRACT FOR EQUIP TO DETECT CRITICAL DEFECTS WAS AWARDED. BASED ON LOAD PLANTS RECOMMENDATION, LINE LAYOUT CONCEPT WAS CHANGED FROM A SINGLE SERIAL TO ONE WITH EQUIP SITED IN THREE SEPARATE AREAS.	1,400.0	565.1	272.5	DEC 79	SEP 80
5 79 4000	AUTOMATED M55 DETONATOR PBN EQUIPMENT THIS PROJECT WAS JUST FUNDED. NO STATUS REPORT WAS REQUIRED.	1,600.0				
5 79 4007	EVALUATION - ACETIC ANHYDRIDE RECYCLE THIS PROJECT WAS JUST FUNDED. NO STATUS REPORT WAS REQUIRED.	316.0				

MANUFACTURING METHODS AND TECHNOLOGY PROGRAM
 S U M M A R Y P R O J E C T S T A T U S R E P O R T
 2ND SEMIANNUAL SUBMISSION CY 78 RCS DRGMT-301

PROJ NO.	TITLE + STATUS	AUTHORIZED (\$000)	CONTRACT VALUES (\$000)	EXPENDED LABOR AND MATERIAL (\$000)	ORIGINAL PROJECTED COMPLETE DATE	PRESENT PROJECTED COMPLETE DATE
5 74 4009	AUTO OF EQUIP FOR A/P OF SMALL SHAPED CHARGE ROCKETS SEE PROJECT 5 76 4009 FOR WORK STATUS.	1,045.0	829.4	215.6	MAY 75	JUN 79
5 75 4009	AUTO OF EQUIP FOR A/P OF SMALL SHAPED CHARGE ROCKETS SEE PROJECT 5 76 4009 FOR WORK STATUS.	650.0	389.9	258.5	SEPT 76	JUN 79
5 76 4009	AUTO OF EQUIP FOR A/P OF SMALL SHAPED CHARGE ROCKETS THE LAP PACKOUT SYSTEM WAS ACCEPTED AND SHIPPED TO LONE STAR AAP.	780.0	519.5	205.6	MAR 77	JUN 79
5 75 4012	FINAL ROLL MILL/PAD-MAKEUP MACHINE FOR MORTAR INCREMENTS OPTIMUM PLOW ARRANGEMENT MAX SHEET WIDTH F/OPERATION OF 2-ROLL CALENDAR WERE DETERMINED. EVALUATION OF THE 4-ROLL CALENDAR W/INERT PROP WAS COMPLETED. SEVERAL FEET OF GOOD QUALITY INERT PROP SHEET WAS PRODUCED.	700.0	597.0	81.1	JUN 76	JUN 79
5 76 4013	CONTINUOUS NC MFG BY THE MAG NITRATE PROCESS PREPARATION OF THE FINAL TECHNICAL REPORT WAS CONTINUED. THE PILOT PLANT PROTECTIVE WORK WAS COMPLETED.	88.0	80.0	7.0	DEC 77	DEC 78
5 79 4024	DSN DEV HLD PROT COMP AND AUTO ASSY MACH M23 FZ THIS PROJECT WAS JUST FUNDED, NO STATUS REPORT WAS REQUIRED.	1,132.0				
5 76 4041	AUTO EQUIP FOR ASSY OF MORTAR COMPONENTS MINOR DRAFTING CHANGES WERE MADE TO THE EQUIPMENT DESIGN. MANUFACTURE OF THE POUNDER WEIGH AND FILL STATION IS NEAR COMPLETION. INCREMENT TEST PARAMETER ESTABLISHMENT AND ALTERNATE INTRINSICALLY SAFE PHOTOCELL TESTS WILL BE COMPLETED BY JANUARY 1979.	427.0	205.5	221.3	JAN 77	JAN 79
5 78 4041	AUTO EQUIP FOR ASSY OF MORTAR COMPONENTS THE FABRICATION OF THE LAP EQUIPMENT IS UNDERWAY. THE SCOPE FOR INSTALLATION AND TEST OF THE LINE AT MAAP WAS FINALIZED. A CONTRACT FOR A SEPARATE PRELIMINARY HAZARDS ANALYSIS OF THE INNOVA LINE WAS LET IN AUG 78.	655.0	537.5	65.6	JUL 79	NOV 79
5 79 4046	QUANTITATIVE ANAL. OF BLENDED EXPLOS. SAMPLES THIS PROJECT WAS JUST FUNDED, NO STATUS REPORT WAS REQUIRED.	307.0				
5 75 4050	AUTOMATED LOADING OF PROPELLANT FLASH REDUCERS COST GROWTH WAS FUNDED. CAROUSEL FUNNELS, SIZED INCORRECTLY TO PASS SPEC GRADE BLACK POWDER, WERE REDESIGNED. GPM SIMULANT WAS FOUND TO BE OUT OF SPEC AND WAS REPLACED. KNO3, FOR USE IN TESTING, HAD LUMPED AND REQUIRED REGRINDING AND PULVERIZING.	1,032.4	833.5	183.4	MAR 76	MAR 79
5 79 4051	IMPROVED INSTR CONTROL FOR ACID PLANTS THIS PROJECT WAS JUST FUNDED, NO STATUS REPORT WAS REQUIRED.	157.0				

MANUFACTURING METHODS AND TECHNOLOGY PROGRAM
 S U M M A R Y P R O J E C T S T A T U S R E P O R T
 2ND SEMI-ANNUAL SUBMISSION CY 76 RCS DRCHT-301

PROJ NO.	TITLE + STATUS	AUTHORIZED (\$000)	CONTRACT VALUES (\$000)	EXPENDED LABOR AND MATERIAL (\$000)	ORIGINAL PROJECTED COMPLETE DATE	PRESENT PROJECTED COMPLETE DATE
5 74 4054	PROC IMPROVED ENG F/MOD+AUTO OF ARTY PROP CHARGE MFR MACHINE SHIPPED FROM CONTRACTOR TO INAAP, ITRI HAS ALMOST COMPLETED MACHINE STATION MODIFICATIONS, REMAINING PROBLEMS ARE BEING RESOLVED. SHIPMENT OF WRUNG GFN FABRIC TO CONTRACTOR CONTRIBUTED TO MILESTONE SLIPPAGE.	710.0	452.4	256.0	MAR 75	JAN 79
5 79 4062	AUTO MFG SYSTEM FOR HURTAR INCREMENT CONTAINERS THIS PROJECT WAS JUST FUNDED, NO STATUS REPORT WAS REQUIRED.	507.0				
5 79 4064	AUTO LAP OPERATIONS FOR 105MM TANK CARTRIDGES THIS PROJECT WAS JUST FUNDED, NO STATUS REPORT WAS REQUIRED.	1,262.0				
5 79 4084	OPACITY/HAZS EMISSION CORRELATION THIS PROJECT WAS JUST FUNDED, NO STATUS REPORT WAS REQUIRED.	121.0				
5 76 4105	AUTO INCREMENT L/A OF PROP CAG WITH CENTRAL CORE IGNITERS FINAL STATUS REPORT F/PHASE 3, ASSEMBLY MODULE, IS IN PROCESS. FY76 FUNDS HAVE BEEN SPENT BUT EQPT DEVELOPMENT WAS NOT TOTALLY COMPLETED. NO ADDITIONAL FY76 FUNDS ARE TO BE PROVIDED.	685.0	537.4	147.6	NOV 76	FEB 79
5 77 4105	AUTO INCR LOG + ASS OF PROP CHGS W/CENT CORE IGN COST GROWTH F/PHASE 4, PACKOUT MODULE, WAS FUNDED, PH 4 PACKOUT DRAWINGS WERE COMPLETED IN PRELIMINARY FORM. OT/OT ON PH 3 EQPT WAS DONE F/X-203 CHARGE, MAINT MANUALS, SPARE PARTS LIST, ORIG DRAWINGS WERE FURNISHED F/LOADING AND ASSEMBLY MODULE.	1,385.0	1,042.6	307.9	MAY 78	AUG 79
5 77 4114	POLLUTION ABATEMENT METHODS FOR P+E SEE PROJECT 5 77 4114.	500.0		488.5		NOV 79
5 73 4114	METHODS TO MINIMIZE ENVIRONMENTAL CONTAMINATION SEE PROJECT 5 77 4114.	6,608.5	3,077.0	1,499.0		JUN 79
5 74 4114	METHODS TO MINIMIZE ENVIRONMENTAL CONTAMINATION SEE PROJECT 5 77 4114.	5,117.0	1,843.2	1,593.3		JUN 79
5 75 4114	METHODS TO MINIMIZE ENVIRONMENTAL CONTAMINATION SEE PROJECT 5 77 4114, 991,71885,3	5,636.4	2,007.3	1,885.3		JUN 79
5 76 4114	METHODS TO MINIMIZE ENVIRONMENTAL CONTAMINATION SEE PROJECT 5 77 4114.	5,200.0	1,429.6	1,628.4		NOV 79
5 76 4114E01	AIR POLLUTION CONTROL PERMIT APPLICATION FOR MISS AAP WAS REVIEWED AND SUBMITTED. WASTE WATER SURVEYS AND WASTE TREATMENT FLOW DIAGRAMS WERE PREPARED FOR CONCEPT PRESENTATION TO EPA. CONCEPT FOR SOLID WASTE DISPOSAL BY ON-SITE LAND FILL WAS OFFERED.	59.0		37.3		JUN 79

MANUFACTURING METHODS AND TECHNOLOGY PROGRAM
 S U M M A R Y R E P O R T S T A T U S R E P O R T
 2ND SEMI-ANNUAL SUBMISSION CY 78 RCS DRCMT-301

PROJ NO.	TITLE + STATUS	AUTHORIZED (\$000)	CONTRACT VALUES (\$000)	EXPENDED LABOR AND MATERIAL (\$000)	ORIGINAL PROJECTED COMPLETE DATE	PRESENT PROJECTED COMPLETE DATE
5 77 4114	DEVELOPMENT OF POLLUTION ABATEMENT TECHNOLOGY SEE FOLLOWING INDIVIDUAL TASKS FOR WORK STATUS.	1,007.2	102.4	601.7	NOV 79	JUN 79
5 77 4114E02	ECOLOGICAL SURVEY OF DARCOM INSTALLATIONS DUGWAY PROVING GROUND HAS COMPLETED ECOLOGICAL SURVEYS AT TEAD AND RMA. IN ADDITION ALL WORK AND REPORTS HAVE BEEN COMPLETED FOR NAAP, RAAP, HAAP, VAAP, TEAD, PBA, AND AAP.				NOV 77	DEC 78
5 77 4114E06	MONITORING TOXIC EFFLUENTS WITH BIO SENSORS VPI CONDUCTED EXP ON WASTE RIVER WATER AND CHLORINATED TAP WATER TO ESTABLISH CRITICAL LIMITS. A TECHNICAL REPORT ON A FISH BIO-MONITORING SYSTEM FOR INDUSTRIAL WASTES WAS PREPARED.	104.6	104.6		APR 79	FEB 79
5 77 4114F02	CONTROL OF POLLUTION GENERATED BY SURFACE TREAT LINES ULTRAFILTRATION UNIT TESTED AT SCRANTON AAP. UNIT WAS EVALUATED AS MEANS OF REGENERATING ALKALI CLEANING SOLN IN THE SURFACE TREATMENT LINES. RESULTS INDICATE THAT SOLUTION LIFE COULD BE EXTENDED FROM ONE WEEK TO PERHAPS SIX WEEKS.				FEB 77	SEP 78
5 77 4114F04	IMPROVED TREATMENT FOR PRIMER MIX PLANT MODIFICATION OF MIXING AREA WAS COMPLETED. SYSTEM IS NOW ABLE TO ACCEPT ANY OVERFLOW FROM EQUALIZATION BASINS AND ENTIRE SYSTEM IS COMPATIBLE WITH PRESENT WASTE TREATMENT SYSTEM. DEBUG HAS BEEN ACCOMPLISHED AND SYSTEM NOW OPERATIONAL.				APR 77	NOV 78
5 77 4114F10	PYROTECHNIC WASTE DISPOSAL TOXIC DEACTIVATION FURNACE HAS BEEN DEBUGGED AND IS NOW BEING USED ON A CONTINUING BASIS.				DEC 76	DEC 78
5 77 4114F13	MONITOR + CONTROL OF POLLUTANTS CONSULTANT UTILIZED TO ASSIST ON INSTALLATION OF MONITORING EGMT TO ANALYZE PAINT SPRAY BOOTH AND FORGING FURNACE EMISSIONS. MODIFICATIONS TO THE CURRENT MONITORING EQUIPMENT WAS PLANNED.				JUN 77	MAY 79
5 77 4114F14	ELIM OF AIR POLLUTION FROM METAL PARTS MFG FINAL RPT WAS PREPARED ON EVALUATION OF THE CHARGED DROPLET SCRUBBER FOR ABATEMENT OF FORGE SHOP EMISSIONS. THE TRM PILOT UNIT EXHIBITED GOOD REMOVAL EFFICIENCIES. ANOTHER UNIT THE SMOG-MOG WILL ALSO BE CONSIDERED FOR ABATEMENT OF FORGE SHOP.				JUN 77	JUL 78
5 77 4114P01	PROGRAM CONTROL, COORDINATION AND SUPPORT VAAP PREPARED RPT ON EMISSIONS VS CAPACITIES. KAAP IS CONTINUING EVALUATION OF ANTHRAFIL AS A PRETREATMENT MEDIA FOR REMOVAL OF SUSPENDED SOLIDS AND WAXES FROM PINK WASTEWATER.	176.5	26.9	116.4	SEP 78	SEP 78

S U M M A R Y P R O J E C T S T A T U S R E P O R T
2ND SEMI-ANNUAL SUBMISSION CY 78 RCS DRGMT-301

PROJ NO.	TITLE + STATUS	AUTHORIZED VALUES (\$000)	CONTRACT VALUES (\$000)	EXPENDED LABOR AND MATERIAL (\$000)	ORIGINAL PROJECTED COMPLETE DATE	PRESENT PROJECTED COMPLETE DATE
5 77 4114P04	NO-X ABATEMENT METHODS GERL COMPLETED STATISTICAL ANALYSES OF OPERATING TEST OF MOLE SIEVE ON 55TPD AOP AT HAAP. DATA INDICATED THAT MOLE SIEVE PROCESS WAS OPERATING WITHIN SPECS AT TIME OF TEST. SYSTEM NOW IN USE AT HAAP FOR NITRIC ACID MANUFACTURE.				NOV 79	NOV 79
5 77 4114P06	PROPELLANT AND EXPLOSIVE WASTE INCINERATION ROTARY-KILN INCINERATOR HAS BEEN MODIFIED FOR AN EXHAUST GAS RECYCLE IN THE SYSTEM. RECYCLE WILL PROVIDE A REDUCING ATMOSPHERE IN MAIN COMBUSTION CHAMBER AND ENHANCE UTILIZATION OF NICKEL OXIDE CATALYSTS. THIS MAY NEGATE NEED FOR EXHAUST SCRUBBERS.				JUN 77	JUN 78
5 77 4114P08	DISPOSAL OF RED WATER FROM TNT PURIFICATION ROTARY KILN TESTS WERE CONDUCTED WITH FUEL OIL IN THE FEED MIX BUT VAPORIZATION OF OIL RESULTED IN LOSS OF REDUCING EFFICIENCY. MULTIPLE HEARTH FURNACE WAS INVESTIGATED AS SUBSTITUTE FOR ROTARY KILN AND FOUND SUITABLE. BENCH SCALE TESTS WERE ACCOMP.				JUN 77	JAN 79
5 77 4114P10	DISPOSAL OF WASTES FROM PROPELLANT MFG AN ULTRAFILTRATION AND REVERSE OSMOSIS UNIT HAVE BEEN INSTALLED AT HAAP. PROBLEM WITH ULTRAFILTRATION UNIT INVOLVED DECREASED FLOW RATE DUE TO THIN FILM OF COLLAGEN ON MEMBRANE. CHEMICAL CLEANING METHODS FAILED TO DISSOLVE FILM.				MAR 79	JUN 79
5 77 4114P12	ELIMINATION OF ORGANIC WASTES SUCH AS SOLVENT FINAL REPORT HAS BEEN REVISED AND RESUBMITTED.				AUG 77	APR 79
5 77 4114P16	PROCESS WATER MANAGEMENT AT GOCO PLANTS FINAL REPORT ON MIXED ACID RECYCLE HAS BEEN COMPLETED. FINAL DESIGN OF EQMT WHICH AFFECT WATER UTILIZATION AT SAAP WAS COMPLETED. CHARACTERIZATION OF SCRUBBER PERFORMANCE WAS DELAYED AT HAAP. EVALUATION OF REUSE OF STEAM CONDENSATE AT KAAP COMPLETED.	377.2	62.0	281.9	NOV 77	JAN 79
5 77 4114P19	METHODS + EQPT TO MONITOR AND CONTROL POLLUTANTS CARRON AND SULEIDE MONITOR WERE REPAIRED. NG MONITOR INSTALLED HOWEVER STABILIZATION PROBLEMS. CONTRACT LET TO XONICS, INC FOR NG VAPOR MONITOR. INSTRUMENTATION FOR NOX CONTROL SYSTEM HAS BEEN ACQUIRED. FINAL RPT ON HYDROCARBON ANALYZER COMPLETED.				JAN 79	MAR 80
5 77 4114P27	SOLID WASTE SOIL DISPOSAL TECHNIQUES COMPOSTING MATL USED WAS HAY AND PAPER. PRELIMINARY STUDIES INDICATED PROBLEMS WITH HEAT LOSSES BUT THEY WERE RESOLVED.				MAR 78	DEC 79
5 77 4114P33	REMOVAL OF NO-X AND TNH FROM NITRATION FUMES BID PACKAGE HAS BEEN PREPARED CNIG SPECS FOR CONTRACT TO INSTALL SULFURIC ACID AND SFLITE SCRUBBING PROCESS AND CONTROL EQMT FOR NOX ABATEMENT FOR TNT MANUFACTURING AT RAAP. ALL EQMT HAS BEEN PROCURED AND 98 PERCENT HAS BEEN RECEIVED.				NOV 79	NOV 79

S U M M A R Y P R O J E C T S T A T U S R E P O R T
2ND SEMI-ANNUAL SUBMISSION CY 76 RCS DRCHT-301

PROJ NO.	TITLE + STATUS	AUTHO- RIZED (\$000)	CONTRACT VALUES (\$000)	EXPENDED LABOR AND MATERIAL (\$000)	ORIGINAL PROJECTED COMPLETE DATE	PRESENT PROJECTED COMPLETE DATE
5 77 411434	OXIDATION OF NITROBODIES FINAL RPT BEING PREPARED BY INNOVA INC ON REMOVAL OF TNT FROM PINK WATER BY ELECTROCHEMICAL TECHNIQUE. FINAL RPT HAS BEEN COMPLETED BY J. BROWN ASSOC ON USE OF WHITE OIL TO REMOVE DISSOLVED TNT TO LESS THAN 1MG/L AFTER SEVEN EXTRACTIONS.	176.5	13.5	156.9	MAY 78	AUG 78
5 76 4122	PRODUCTION LINE MODERNIZATION FOR CRU WEAPONS TDP FOR CRU 52 AND CRU 25/46 PRODUCTION LINES AT MILAN AAP COMPLETE. CONCEPT FOR CRU 58/71 PRODUCTION LINES AT KANSAS AAP COMPLETE.	721.0	128.0	518.0	MAR 77	JUN 78
5 79 4124	FABRICATION OF CONTROL ACTUATION SYSTEM HOUSINGS THIS PROJECT WAS JUST FUNDED, NO STATUS REPORT WAS REQUIRED.	1,530.0				
5 79 4133	AUTO INSPECTION FOR CRITICAL DEFECTS IN THE M55 DETONATOR THIS PROJECT WAS JUST FUNDED, NO STATUS REPORT WAS REQUIRED.	283.0				
5 75 4136	DEVELOPMENT OF A GENERALIZED MATH MODEL TASKS 1.2, 4.5 COMPLETED. SCOPE OF WORK COMPLETED AND PROCUREMENT INITIATED TO EXP AND THE RAM DATA TO INCLUDE ALL ARRADCOM FUNCTIONS UNDER TASK 3.	283.0	80.0	203.0	JAN 76	AUG 79
5 76 4136	DEVELOPMENT OF A GENERALIZED MATH MODEL TASKS 1.2, 4.5 COMPLETED. SCOPE OF WORK COMPLETED AND PROCUREMENT INITIATED TO EXP AND THE RAM DATA TO INCLUDE ALL ARRADCOM FUNCTIONS UNDER TASK 3.	150.0	21.5	101.5	JUN 77	AUG 79
5 78 4139	APPLICATION OF RADAR TO BALLISTIC ACCEPTANCE TEST OF AMMO TEST PLANS FOR CONTRACTORS IN-HOUSE TESTS HAVE BEEN PREPARED. RF RADIATION TOWARDS A FIXED RADAR BEACON HAS BEEN INITIATED. TRANSMITTER AND RECEIVER TESTS HAVE BEEN COMPLETED. 90 PERCENT OF THE SOFTWARE IS COMPLETE.	1,565.0	979.4	130.6	FFH 79	JUN 79
5 76 4143	MFG OF CANISTERS AND COMP F/M259 + M264 ROCKETS THREE BID RESPONSES WERE RECEIVED AND EVALUATED. GARD INC. WAS RECOMMENDED FOR AWARD.	160.0	82.2	12.0		MAR 80
5 70 4147	COMPUTER CONTROL APPLICATION TO CONTINUOUS TNT MANUFACTURE THE DRAFT OF THE CONTRACTOR-PREPARED REPORT WAS REVIEWED BY ARRADCOM PERSONNEL. A MEETING WAS HELD AT VAAP TO DISCUSS MODIFICATIONS. THE FINAL DRAFT OF THE REPORT WAS BEGUN, ITS EXPECTED ISSUE DATE IS 31 DEC 78.	1,252.5	1,217.5	35.0	MAY 73	JAN 79
5 74 4147	COMPUTER CONTROL APPLICATION TO CONTINUOUS TNT MANUFACTURE DETAILED SYSTEM DESIGN AND HARDWARE FABRICATION FOR THE ANALOG CONTROL SYSTEM AT RAAP WAS COMPLETED. MOST OF THE FIELD EQUIPMENT IS AT RAAP. A SUCCESSFUL PRESHIPMENT DEMONSTRATION OF THE CONTROL ROOM EQUIPMENT WAS CARRIED OUT IN OCTOBER 78.	795.0	750.0	30.0	NOV 75	DEC 79

MANUFACTURING METHODS AND TECHNOLOGY PROGRAM
 S U M M A R Y R E P O R T S T A T U S R E P O R T
 2ND SEMIANNUAL SUBMISSION CY 78 RCS DRCMT-301

PROJ NO.	TITLE + STATUS	AUTHOR- RIZED (\$000)	CONTRACT VALUES (\$000)	EXPENDED LABOR AND MATERIAL (\$000)	ORIGINAL	PRESENT
					PROJECTED COMPLETE DATE	PROJECTED COMPLETE DATE
5 78 4149	LOADING OF 10MM ADEN/DEFA HEDP AMMUNITION THE CONTRACT FOR THE PROJECT WAS SIGNED WITH HONEYWELL. A KICK-OFF MEETING WAS HELD AT HONEYWELL AND BASELINES WERE ESTABLISHED TO COINCIDE WITH THE GOVERNMENT SOM.	500.0	406.0	34.3	MAY 79	OCT 79
5 78 4150	NEW MANUFACTURING PROCESSES FOR SAMS AMMUNITION ALTERNATE PENETRATOR FEEDER AND ASSEMBLY SYSTEMS INVESTIGATED WITH RESPECT TO IMPACT ON SUBMODULE DSN INITIATED. SKEMED AXIS ROLL SYSTEM CAPABLE OF WORKING 1095 STEEL INVESTIGATED. SOM AND PROCUREMENT PACKAGE FORMULATED FOR TOOL DEVELOPMENT DESIGN.	50.0	5.0	20.9	SEP 80	SEP 80
5 78 4153	INERTIA WELDER FOR THE M509 AND M483 PROJECTILES A CONTRACT IS IN THE PROCESS OF BEING LET.	350.0	9.0	9.0	AUG 80	JAN 80
5 78 4163	CONTROLLED PRODUCTION LOADING F/1105 MM HEAT M456 LOADING TESTS WERE CONDUCTED WITH MODIFIED TOM/DRAAGON C487 LOADING EQUIPMENT AND FIXTURES ON LINE 1 AT IOWA AAP. TEST RUNS WERE ALSO MADE ON LINE 2 WITH SPIKES REMOVED FROM PROJECTILE METAL PARTS.	199.0	125.0	74.0	MAR 79	MAR 79
5 77 4202	PROTO EG F/CONT AUTO PROD OF SOLVENT- TYPE MULTI-BASE PROP 3000LB OF M30A1 WAS SHIPPED TO INAAP, BAG LOADED, AND SHIPPED TO APG WHERE GUN TESTS WERE CONDUCTED ON THE M203, 15MM, MG EXPLOSION AT RAAP CAUSED TERMINATION OF WORK ON PROTOTYPE LINE. ONLY WORK PURSUED IS DATA ANALYSIS WINTERIZING PROTOTYPE LINE.	505.0	308.0	163.5	MAR 78	MAR 79
5 76 4211	MOD OF PROCESS CONTROL OF EXPLOSIVE COMPOSITIONS THE GAMMA RAY RDX/TNT COMPOSITION ANALYZER SYSTEM DESIGN HAS SPECIFIED BASED ON LAB DATA. THE DETECTION SYSTEM WAS PROCURED. SCIENCE APPL INC HAS PREPARED A SAFETY AND HAZARD REPORT FOR THE RDX/TNT CONCENTRATION SENSOR.	175.0	1.5	173.5	MAY 77	FEB 79
5 77 4211	MOD OF PROCESS CONTROL OF EXPLOSIVE COMPOSITIONS BASED ON A LITERATURE SEARCH INFORMATION A SCOPE OF WORK WAS PREPARED FOR AN AUTOMATED IMPACT TESTOR.	427.0	154.5	109.8	AUG 78	JUL 80
5 78 4214	POLLUTION ENGINEERING FOR 1983-85 REQUIREMENTS SEE FOLLOWING INDIVIDUAL TASKS FOR WORK STATUS.	1,180.0	510.0	339.3	SEP 79	DEC 79
5 78 4214P1	TECHNOLOGY REQUIREMENTS REVIEW OF SLUDGE PROCESSING TECHNOLOGY RECEIVED FROM EPA. MEETING HELD ON AEMA TEST PROGRAM FOR PROCESS EVAL STDY OF DET INT. MCA PROGRAMS FOR INT (JAAP), CAMBL (RAAP), AND LAP (IAAP) WERE REVIEWED FOR POLL ABAT CONTROL AND FOUND ACCEPTABLE.	211.7	75.0	75.0	SEP 79	SEP 79

S U M M A R Y P R O J E C T S T A T U S R E P O R T
 2ND SEMIANNUAL SUBMISSION CY 78 WCS DRCHT-301

MANUFACTURING METHODS AND TECHNOLOGY PROGRAM

PROJ NO.	TITLE + STATUS	AUTOMATED RIZED (\$000)	CONTRACT VALUES (\$000)	EXPENDED LABOR AND MATERIAL (\$000)	ORIGINAL PROJECTED COMPLETE DATE	PRESENT PROJECTED COMPLETE DATE
5 78 4214P2	IN-PLANT REUSE OF POLLUTION ABATED WATERS CSL-RPT ON PHASE 1 OF AMMONIA RECOVERY SYST COMPLETE. A LINEAR PROG ALGORITHM HAS BEEN SELECTED AND LOADED INTO COMPUTER. MAAP-PARAMETERS AFFECTING END PRODUCT OR WATER DIST SYSTEM DETERMINED. DATA ON WATER QUALITY CRITERIA FOR PLANT COLLECTED.	377.0	130.3	166.1	JUL 79	NOV 79
5 78 4214P3	LOW COST SYSTEM TO ABATE NITROBODDY POLLUTION BENCH SCALE STUDIES ON UV/OZONOLYSIS, OIL SOLVENT EXT, AND ELECTROCHEM OXID INDICATE THEY ARE EFFECTIVE IN REDUCTION OF NITROBODIES. IO=4 AAP WAS FUNDED FOR DEMO OF UV/OZONOLYSIS AND WHITE OIL SOLVENT EXTRACTION METHODS.	355.0	220.0	79.9	JUL 79	JUL 79
5 78 4214P4	NG-NITRATE ESTER REMOVAL BY ADSORPTION/RECYCLE BUILDING SITE AT MAAP WAS SELECTED FOR PILOT WORK. ADSORBENT RESIN FOR SEPARATION OF NITRATE ESTERS WERE TESTED. DATA INDICATED ROM/MAAS RESINS XAD-4 AND 1601 PERFORMED BETTER THAN NINE OTHER RESINS.	236.0	150.0	29.0	JUL 78	JUN 79
5 79 4214	POLLUTION ENGINEERING FOR 1983-85 REQUIREMENTS THIS PROJECT WAS JUST FUNDED. NO STATUS REPORT WAS REQUIRED.	1,269.0				
5 74 4215	AUTO THE CONTINUOUS TNT PROD FACILITY PROCESS CONTROLS IT WAS CONCLUDED THAT THE PRESENT ANALYZER SAMPLING MODULE DESIGN WAS NOT ACCEPTABLE FOR ON-LINE TNT SET POINT ANALYSIS. THE DESIRED ACCURACY AND PRECISION FOR ON-LINE OPERATION COULD NOT BE OBTAINED.	323.8	220.6	99.2	MAY 75	MAY 79
5 77 4223	APPLICATION OF ULTRASONIC ENERGY TO DOUBLE-BASE PROP PROC THE D.C. POWER SUPPLY WAS MODIFIED AND THE INVERTER CIRCUITRY WAS REDESIGNED AND REBUILT. A THREE PHASE VARIAL WAS LOCATED AND ADOPTED AS A REPLACEMENT VARIABLE POWER SOURCE.	330.0	57.8	231.2	SEP 78	DEC 79
5 78 4228	AUTOMATED BAG LOADING/CHARGE ASSEMBLY + PACKOUT=ISSMM/81M DEMONSTRATION OF THE ASSEMBLY MACHINE AND PACKOUT MODULE WAS SATISFACTORILY DEMONSTRATED. BOTH WERE SHIPPED TO INDIANA AAP. PREPARATION OF THE TOP FOR THE ASSEMBLY MACHINE IS IN PROGRESS.	404.0		92.6	AUG 78	OCT 78
5 77 4237	CONTINUOUS TNT PROCESS ENGINEERING A TRAINING PROGRAM WAS STARTED TO FAMILIARIZE THE ENGINEERS WITH THE REMOTE OPERATING CONTROLS AND MONITORING EQUIPMENT. APPLICATION PROGRAMMING OF THE PILOT PLANT CONTROL COMPUTER CONTINUED. FIELD EQUIPMENT INSTALLATION WAS COMPLETED.	265.0	7.8	257.2	FEB 78	DEC 78
5 78 4237	CONTINUOUS TNT PROCESS ENGINEERING THE CHILLED WATER, BRINE, AND DEMINERALIZED WATER UTILITIES BECAME OPERATIONAL. MECHANICAL AND WATER TESTING OF THE INSTALLED EQUIPMENT WAS INITIATED. CONTRACTS WERE PLACED FOR FLOOR REFINISHING AND FOR THE INSTALLATION OF A SPRINKLER AND DELUGE SYST	300.0	9.0	66.8	FEB 79	AUG 79

MANUFACTURING METHODS AND TECHNOLOGY PROGRAM
 S U M M A R Y P R O J E C T S T A T U S R E P O R T
 2ND SEMI-ANNUAL SUBMISSION CY 78 RCS DRCMT-301

PROJ NO.	TITLE + STATUS	AUTHOR SIZED (8000)	CONTRACT VALUES (8000)	EXPENDED LABOR AND MATERIAL (8000)	ORIGINAL	PRESENT
					PROJECTED COMPLETE DATE	PROJECTED COMPLETE DATE
5 77 4249	SEPARATION OF FINE EXPLO FROM ACID, WATER SLURRIES BIRD-PANNEVIS FILTER WAS DELIVERED TO HAAP 8 NOV 78. MINOR DAMAGE INCURRED DURING SHIPMENT. CLAIM FILED AGAINST CARRIER. NEW PARTS WILL BE WRO BY BIRD AND INSTALLED BY HAAP. REPAIRS WILL BE MADE DURING INSTALLATION.	350.0	280.0	70.0	DEC 77	JUN 79
5 78 4249	SEPARATION OF EXPLOSIVES FROM SPENT ACID / WATER SLURRIES AN INSTALLATION MATERIALS LIST WAS PREPARED BASED ON DRAWING PACKAGE. PURCHASE REQUISITIONS FOR INSTALLATION MTLs PREPARED AND SUBMITTED FOR VENDOR QUOTES OR DIRECT PURCHASE. REQUEST MADE FOR ADDITIONAL FUNDS TO THE PBM.	250.0	220.0	2.7	DEC 78	MAR 80
5 75 4252	IMPROVE PRESENT PROCESSES FOR THE MANUFACTURE OF RDX + HMX AN INERT (WATER) CHECKOUT OF THE PILOT PLANT WAS STARTED 20 NOV 78. ALL SWITCHES FOR PUMPS, MOTORS, AGITATORS, ETC. HAVE BEEN CHECKED. REPAIRS WERE MADE ON BLDG UTILITIES	550.0	536.4	13.6	DEC 75	MAY 79
5 77 4252	IMPROVE PRESENT PROCESSES FOR THE MANUFACTURE OF RDX + HMX A DUAL PRECOAT PROCESS WAS SELECTED AS A NEW METHOD FOR MER OF C-4. C-4 WAS PUMPED USING AN IMPELLER AND 88 LINES. ADDITION OF PARAFORMALDEHYDE INCREASED HMX IN RDX PRODUCT. REDUCTION OF AMMO NITRATE AND ACETIC ANHYDRIDE PRODUCED MORE HMX.	884.2	653.1	115.7	DEC 77	JAN 80
5 78 4252	IMPROVE PRESENT PROCESSES FOR THE MANUFACTURE OF RDX + HMX SAFETY EQUIPMENTS PURCHASED FOR PILOT PLANT.	548.0		7.9	MAY 80	APR 81
5 76 4263	AUTO PILOT LINE FOR CONTROLLED COOL/PROCESSING HE LOAD PROJ THE PROJECT HAS BEEN COMPLETED AND A FINAL REPORT WILL BE PREPARED.	1,145.0	778.7	368.0	JUN 77	JUL 79
5 77 4263	AUTO PILOT LINE FOR CONTROLLED COOL/PROCESSING HE LOAD PROJ TESTS ON THE METAL PARTS PREHEATER TO DETERMINE TEMP CORRELATIONS WERE RUN. RTU INPUT FROM THE THERMAL PANELS TO THE WATER BATH WAS DETERMINED. DERUG OF PROJ WORK STATIONS WERE STARTED.	900.0	153.4	711.1	SEP 78	JUL 79
5 78 4263	AUTO PILOT LINE FOR CONTROLLED COOL/PROCESSING HE LOAD PROJ THE EXPANDED MELT-POUR PILOT PLANT WAS OPERATED AS A AUTOMATIC, REMOTE PROCESSING SYSTEM. REACTIVATION OF THE MELT-POUR FAC HAS BEEN HAMPERED BY RODENT DAMAGE TO THE ICMS, HARDWARE DETERIORATION AND CONSTRUCTION CONTRACTOR FAILING TO COMPLETE WORK.	257.0	51.2	175.8	OCT 78	SEP 79
5 77 4267	CONTINUOUS PROCESS FOR GRANULAR COMPOSITION B INERT TEST RUNS USING A TWO FLUID NOZZLE WERE PERFORMED AT NIRO ATOMIZER. A FINAL PRODUCT WITH A RULK DENSITY OF 1G/CC WAS OBTAINED. A VISIT WAS MADE TO CANADIAN IND LTD TO OBSERVE PELLETING PROCESS AS APPLIED TO HFG COMP B. HAAP WILL BENCH SCALE.	500.0	429.3	52.9	SEP 79	JUN 81

MANUFACTURING METHODS AND TECHNOLOGY PROGRAM
 SUMMARY PROJECT STATUS REPORT
 2ND SEMIANNUAL SUBMISSION CY 78 RCS DRCHT-301

PROJ NO.	TITLE + STATUS	AUTHORIZED (\$000)	CONTRACT VALUES (\$000)	EXPENDED LABOR AND MATERIAL (\$000)	ORIGINAL PROJECTED COMPLETE DATE	PRESENT PROJECTED COMPLETE DATE
5 78 4267	CONTINUOUS PROCESS FOR GRANULAR COMPOSITION B NO WORK ACCOMPLISHED.	425.0	171.0		MAR 81	DEC 81
5 76 4280	M577 FUZE AUTOMATIC PROCESS CONTROL PROTOTYPE EQUIPMENT TESTING OF ULTRASONICALLY STAKED COUNTER HOUSING SAMPLES INDICATED THAT THE DESIGN IS NOT SATISFACTORY. PRELIMINARY TESTING WITH REDESIGNED PARTS PROVED SATISFACTORY. TESTING AND FABRICATION OF THE ZERO SET MACHINE IS CONTINUING.	208.0	162.9	43.6	AUG 76	JUL 79
5 77 4280	M577 FUZE AUTOMATIC PROCESS CONTROL PROTOTYPE EQUIPMENT THE POISING MACHINE AND REGULATION MACHINE HAVE BEEN COMPLETED AND ACCEPTANCE TESTS SATISFACTORILY PERFORMED. FUZE TEST SAMPLES PASSED BALLISTIC TESTING. FINAL REPORTS ARE BEING PREPARED.	900.0	684.0	61.5	MAR 78	JUL 79
5 76 4281	ENERGY SAVING AT ARMY AMMO PLANTS SEE WORK ON INDIVIDUAL SUBTASKS.	875.0	421.6	447.0	OCT 78	SEP 79
5 76 4281A01	PROCESS ENERGY INVENTORY ALL FY76 FUNDS ALLOCATED FOR THIS SUBTASK HAVE BEEN SPENT. WORK ON THIS SUBTASK CONTINUES IN FY77 AND 78.	375.0	125.0	250.5	OCT 77	SEP 75
5 76 4281A04	WASTE HEAT FROM CHEMICAL REACTIONS THE FINAL REPORT ON RECOVERY OF WASTE HEAT FROM A PROPELLANT FORCED AIR DRY HOUSE WAS PUBLISHED.	375.0	212.6	155.4	OCT 77	NOV 78
5 76 4281B01	PROCESS ENERGY INVENTORY FOR METAL PARTS WORK ON THIS SUBTASK IN FY76 IS COMPLETE. WORK CONTINUES WITH FY77 AND FY78 FUNDS.	60.0	49.0	11.1	OCT 78	FEB 77
5 76 4281B02	REDUCED FORGING TEMPERATURE NO ADDITIONAL WORK REPORTED OVER THE PREVIOUS PERIOD.	650.0	35.0	30.0	JUN 77	JUN 79
5 77 4281	ENERGY SAVING AT ARMY AMMO PLANTS SEE WORK UNDER INDIVIDUAL SUBTASKS.	1,000.0	571.2	389.1	SEP 79	MAR 80
5 77 4281A01	PROCESS ENERGY INVENTORY STEAM MONITORING INSTRUMENTATION WAS INSTALLED ON AN OPEN AIR DRY TANK AND A FORCED AIR DRY HOUSE AT RAAP. IN ADDITION THE NAC/SAC PROCESS AREA WAS ALSO EQUIPPED WITH THE INSTRUMENTATION. THE ACTUAL ENERGY USED WILL BE COMPARED WITH THE THEORETICAL.	348.0	262.4	67.6	JUN 79	SEP 79
5 77 4281A04	WASTE HEAT FROM CHEMICAL REACTIONS RAAP NEGOTIATED WITH TRW FOR TECHNICAL SUPPORT ON A DEMONSTRATION PROJECT TO RECOVER HEAT FROM THE NC BOILING TUB HOUSE. RAAP INITIATED EFFORTS TO IDENTIFY OPERATIONAL CHARACTERISTICS OF THE BOILING TUB HOUSE.	193.8	64.2	123.4	AUG 79	MAR 80

S U M M A R Y P R O J E C T S T A T U S R E P O R T
 2ND SEMI ANNUAL SUBMISSION CY 78 RCS DRGMT-301

PROJ NO.	TITLE + STATUS	AUTHOR- RIZED (8000)	CONTRACT VALUES (8000)	EXPENDED LABOR AND MATERIAL (8000)	ORIGINAL PROJECTED COMPLETE DATE	PRESENT PROJECTED COMPLETE DATE
5 77 4281A08	CAVITATIONAL REMOVAL OF EXPLOSIVES REMOVAL OF EXPLOSIVES FROM PROJECTILES USING A CAVITATING JET WAS DEMONSTRATED TO BE SAFE. NOZZLE DESIGN AND OPERATING CONDITIONS WERE ESTABLISHED AND WILL BE USED AS THE FIRST TRIAL DURING THE PILOT PLANT PHASE OF THE PROGRAM.	301.2	143.8	133.0	SEP 79	JUN 79
5 77 4281B01	PROCESS ENERGY INVENTORY FOR METAL PARTS A MEETING WAS PLANNED TO REVIEW THE FINAL REPORT WITH LCAAP AND TRM. HOWEVER FUNDS WERE LACKING ON THE CONTRACT WITH TRM. ACTIONS WERE TAKEN TO LET A NEW CONTRACT WITH TRM. THE MEETING IS PLANNED FOR THE NEXT REPORT PERIOD.	59.0	41.0	17.9	FEB 78	MAY 79
5 77 4281B02	REDUCED FORGING TEMPERATURE INSTRUMENTATION WAS INSTALLED WHICH WILL MEASURE ENERGY CONSUMPTION IN THE FURNACE AND PRESS EQUIPMENT WHEN OPERATING AT REDUCED FORGE TEMPERATURES.	98.0	51.0	47.0	FEB 78	JUN 79
5 78 4281	ENERGY SAVING AT ARMY AMMO PLANTS SEE WORK UNDER INDIVIDUAL SUBTASKS.	1,062.0	852.5	46.3	MAR 80	MAR 80
5 78 4281A01	PROCESS ENERGY INVENTORY INSTRUMENTATION FOR MEASURING STEAM, AIR, AND ELECTRICITY WAS PROCURED, RECEIVED, AND INSTALLED IN THE MELT-POUR OPERATION OF THE M7242 LAW LINE AT LSAAP. AIR FLOW AND ELECTRICAL METERING DEVICES ARE BEING PROCURED FOR USE AT KANSAS AAP.	177.0	118.0	8.6		SEP 79
5 78 4281A04	ENERGY RECOVERY FROM WASTE HEAT NO PROGRESS WAS REPORTED FOR THIS SUBTASK UNDER THIS FISCAL YEAR OF EFFORT.	326.0	303.7	3.3		MAR 80
5 78 4281A05	ENERGY RECOVERY FROM WOOD WASTE CONTRACT WAS AWARDED TO TRM TO DETERMINE THE FEASIBILITY OF USING WOOD WASTE AS A VIABLE FUEL SOURCE. SURVEYS OF SITE ENERGY REQUIREMENTS AND OF AVAILABLE BIOMASS FEEDSTOCK WERE MADE. PRELIMINARY REVIEWS OF VARIOUS CONVERSION PROCESSES WERE MADE.	75.0	75.0			MAR 79
5 78 4281A08	CAVITATIONAL REMOVAL OF EXPLOSIVES A SCOPE OF WORK FOR DESIGN, CONSTRUCTION, AND EVALUATION OF THE PILOT FACILITY WAS COORDINATED WITH IOWA AAP. HYDRONAUTICS TECHNICAL PROPOSAL FOR A FACILITY TO REMOVE EXPLOSIVES FROM PROJECTILES WAS RECEIVED, REVIEWED, AND REVISED.	295.0	285.6	2.4		SEP 80
5 78 4281B01	PROCESS ENERGY INVENTORY FOR METAL PARTS NO PROGRESS WAS REPORTED FOR THIS SUBTASK UNDER THIS FISCAL YEAR OF EFFORT.	72.0		18.8		MAY 79

8 U M M A R Y P R O J E C T S T A T U S R E P O R T
 2ND SEMIANNUAL SUBMISSION CY 78 RCB DREMT-301

PROJ NO.	TITLE + STATUS	AUTHORIZED (8000)	CONTRACT VALUES (8000)	EXPENDED LABOR AND MATERIAL (8000)	ORIGINAL PROJECTED COMPLETE DATE	PRESENT PROJECTED COMPLETE DATE
5 78 4261804	WASTE HEAT RECOVERY AMAF INDUSTRIES WAS AWARDED A CONTRACT TO PERFORM THE WASTE HEAT RECOVERY STUDY AT SCRANTON AAP, OF 4 PHASES, PH 1, REVIEW EXISTING ENERGY SURVEY DATA, AND PH 2, CONDUCT IN-PLANT REVIEW HERE COMPLETED, PH 3, WASTE HEAT DATA GATHERING WAS INITIATED.	117.0	80.2	13.2		FEB 79
5 79 4261	CONSERVATION OF ENERGY AT ARMY AMMUNITION PLANTS THIS PROJECT WAS JUST FUNDED, NO STATUS REPORT WAS REQUIRED.	1,285.0				
5 77 4265	TNT EQUIVALENCY TESTING FOR SAFETY ENGINEERING CONTINUED EFFORTS INITIATED IN FY76 TO REVIEW CONTRACTOR EFFORTS AND PREPARE FINAL REPORTS ON MATERIALS SUCH AS NITROBODIES.	81.0		81.0	NOV 77	JUN 79
5 76 4265	TNT EQUAL TESTING IN SUPPORT OF SAFETY ENGIN FOR AMMO PLANTS REPORTS ON THE FOLLOWING PROPELLANTS WERE PUBLISHED - M26E1, B9 NACO, COMP A5, M10, AND M30.	325.0	130.0	195.0	FEB 77	JUN 79
5 77 4265	TNT EQUIVALENCY TESTING FOR SAFETY ENGINEERING. BALL POWDER TEST RESULTS WERE ANALYZED. ADDITIONAL TESTING WAS DEEMED NECESSARY. PRELIMINARY REPORTS ARE IN PROCESS ON BENITE, TRACER COMPOSITION R-284, AND IGNITER COMPOSITIONS 1560 AND 1559.	380.0	87.9	266.7	APR 78	JUN 79
5 78 4265	TNT EQUIVALENCY TESTING FOR SAFETY ENGINEERING TESTS ON COMP C-4 AND NITROCELLULOSE WERE COMPLETED. RESULTS ARE BEING ANALYZED ON THE COMP C-4 TESTING AND A PRELIMINARY REPORT IS IN PROCESS ON THE MC TESTING. A TEST PLAN ON COMP A-3 WAS FORWARDED FOR SAFETY CONCURRENCE.	400.0	37.9	137.7	JUL 79	MAR 80
5 79 4265	TNT EQUIVALENCY TESTING FOR SAFETY ENGINEERING THIS PROJECT WAS JUST FUNDED, NO STATUS REPORT WAS REQUIRED.	420.0				
5 77 4266	EXPLOSIVE SAFE SEPARATION AND SENSITIVITY CRITERIA SAFE SEPARATION DISTANCE FOR 155MM PROJ WAS ESTABLISHED AT 5 FEET. SHIELDED PROJECTILES INDICATE 3 INCH SS DISTANCE. SS DISTANCE FOR 8 INCH M106 PROJECTILES SHIELDED WAS ESTABLISHED AT 1 FOOT. PRELIMINARY TESTS OF CBU LOADINGS HAVE BEEN COMPLETED.	600.0	383.9	155.2	OCT 78	OCT 78
5 78 4266	EXPLOSIVE SAFE SEPARATION AND SENSITIVITY CRITERIA SAFE SEPARATION DISTANCE TESTS CONDUCTED ON 155MM M483 PROJ WITH AND -70 SHIELDS. SS DISTANCE TESTS OF FLAKE TNT IN AL TOTE BINS CONDUCTED IN TUNNELS AT MSTL STATION. PRIMARY FRAGMENT IMPACT TESTS COMPLETED ON CAGED TNT CHARGES.	826.0	221.9	153.4	FEB 79	FEB 79
5 79 4266	EXPLOSIVE SAFE SEPARATION AND SENSITIVITY CRITERIA THIS PROJECT WAS JUST FUNDED, NO STATUS REPORT WAS REQUIRED.	643.0				

S U M M A R Y P R O J E C T S T A T U S R E P O R T
 2ND SEMIANNUAL SUBMISSION CY 78 RCS DRGMT-301

PROJ NO.	TITLE + STATUS	AUTHORIZED (\$000)	CONTRACT VALUE (\$000)	EXPENDED LABOR AND MATERIAL (\$000)	ORIGINAL PROJECTED COMPLETE DATE	PRESENT PROJECTED COMPLETE DATE
5 77 4289	HAZARD CLASSIFICATION OF PROPELLANTS AND EXPLOSIVES TESTS WITH MULTI-BASE PROPELLANT IN THE ONE-THIRD AND ONE-HALF SCALED DRYER WERE COMPLETED. RESULTS INDICATE THAT FOR THE CONTINUOUS AUT MULTI-BASE LINE DRYER WITH A VENT RATIO OF 235) M,30 PROPELLANT CAN BE CLASSIFIED AS CL=1.2 OR 1.3 BURNING ONLY.	65.0	13.0	51.2	APR 78	JUN 78
5 76 4289	STUDIES OF HAZARD CLASSIFICATION OF EXPLOSIVES AND PROPELLANT WORK HAS BEEN COMPLETED. TECHNICAL REPORT HAS BEEN ISSUED.	250.0	196.0	54.0	JAN 78	AUG 78
5 77 4289	STUDIES OF HAZARD CLASSIFICATION OF EXPLOSIVES AND PROPELLANT EQUIPMENT AND INSTR FOR MEASURING ELECTROSTATIC DISCHARGE HAVE BEEN ASSEMBLED. CRITICAL DIAM AND LENGTH TESTS CONDUCTED ON M1, M26, AND RDX. AIRBLAST TESTS WERE COMPLETED ON FOUR MATLS. BURNING RATE OF WAS DETERMINED BY FIRESREAD TESTS.	306.0	187.6	103.5	AUG 78	NOV 78
5 78 4289	STUDIES OF HAZARD CLASSIFICATION OF EXPLOSIVES AND PROPELLANT TEST PROGRAM FOR EVALUATION OF RUST HAZARDS FOR PYROTECHNIC IS NEARLY COMPLETE. MINIMUM DUST CONCENTRATION LEVELS ON EIGHT SAMPLE MATERIALS HAS BEEN OBTAINED.	214.0	115.0	33.3	DEC 78	DEC 78
5 77 4291	BLAST EFFECTS IN MUNITION PLANT ENVIRONMENT FUNDING USED ONLY FOR DEVELOPMENT OF INFO ON STEEL ACCEPTOR STRUCTURES. TEST PLAN ADDITIONS HAVE SUPPOSEDLY DELAYED TEST START. BLAST CAPACITY REPT IS IN REVIEW. COMPUTER PGM DYNPA WAS REVISED. ERECTION OF STRENGTHENED STEEL BLDG UNDERWAY.	350.0	176.1	76.2	JUN 78	JUN 79
5 79 4291	BLAST EFFECTS IN THE MUNITIONS PLANT ENVIRONMENT THIS PROJECT WAS JUST FUNDED. NO STATUS REPORT WAS REQUIRED.	600.0				
5 77 4301	ACCEPT PLAN FOR CONTINUOUSLY PROD MULTIBASE CANNON PROP-CAM ALL FUNDING FOR THIS PROJECT HAS BEEN SPENT. PREPARATION OF A FINAL 301 REPORT IS UNDERWAY.	110.0	15.0	95.0	JAN 77	MAR 79
5 76 4301	ACCEPT PLAN=CONT PRODUCE MULTI-BASE CANNON PROPELLANT ALL FUNDING FOR THIS PROJECT WAS BEEN SPENT. PREPARATION OF A FINAL 301 REPORT IS UNDERWAY.	395.0	180.0	215.0	OCT 76	MAR 79
5 77 4301	ACCEPT PLAN=CONT PRODUCTION MULTI-BASE CANNON PROPELLANTS CONTRACT FOR DESIGN + FABRICATION OF AN ADVANCED DYNAMGUN BALLISTIC SIMULATOR WAS LET. THE CONTRACTORS PRELIMINARY RESULTS WERE PRESENTED TO ARRADCOM, NINE LOTS OF M30 WAS PRODUCED AND CHEMICALLY TESTED AT RAAP AS PART OF THE PROCESS VARIABILITY STUDY	500.0	230.0	207.0	MAY 78	OCT 79
5 77 4302	ACCEPTANCE CRITERIA FOR CONTINUOUS SINGLE BASE PROPELLANT WORK HAS BEEN COMPLETED. PREPARATION OF FINAL REPORTS AND SPECIFICATIONS ARE UNDERWAY.	75.0	8.0	67.0	SEP 77	MAR 79

S U M M A R Y P R O J E C T S T A T U S R E P O R T
2ND SEMI-ANNUAL SUBMISSION CY 78 RCS DRCHT-301

PROJ NO.	TITLE + STATUS	AUTHORIZED (\$000)	CONTRACT VALUES (\$000)	EXPENDED LABOR AND MATERIAL (\$000)	ORIGINAL PROJECTED COMPLETE DATE	PRESENT PROJECTED COMPLETE DATE
5 77 4327	AUTOMATIC X-RAY INSPECTION SYSTEM-AXIS THE CONTRACTOR DEMONSTRATED THE FEASIBILITY OF AN AUTOMATED FILM READING SYSTEM, THE AMOUNT OF TIME REQUIRED TO DETECT THE FLAWS IS LENGTHY. HOWEVER, THIS SHOULD NOT IMPAIR THE DEVELOPMENT OF THE PROTOTYPE SYSTEM.	100.0	100.0		JUL 79	JAN 80
5 76 4337	ALTERNATE MATERIALS FOR CURING/MULDING PROCESS F/PAP MINES COMPLETED COMPATIBILITY TESTING OF ADAM COMPOUND AND ATC-3 ACCEL WITH PHX-NS PB STYPHATE AND RDX. STARTED SIMILAR TESTING WITH ADAM PROPELLANT MIX. APPROACH OUTLINED FOR TESTING IMPACT OF ATC-3 ON PRESENT ADAM POTTING COMPOUND PROPERTIES.	504.0	190.0	109.7	AUG 78	MAR 79
5 76 4338	DEV AUTO PROCESS + PROTO EQUIP FOR LAP OF M483 15MM PROJ FABRICATION OF THE 30 PPM TAPE STIFFENER ASSEMBLY MACHINE IS CONTINUING. WORK ON THE 90 PPM ASSEMBLY MACHINE HAS BEEN STOPPED. THE GRENADE PREPACK WILL BE REDESIGNED TO HAVE A DUAL PURPOSE CAPABILITY SO IT CAN BE USED FOR THE M509 AND M483 PROJECTILE	758.6	654.6	63.4	MAR 79	MAY 80
5 77 4341	IMPROVED NITROCELLULOSE PURIFICATION PROCESS A DESIGN OF THE PROTOTYPE CONCELL UNIT WAS SELECTED. THE DESIGN WILL ALLOW ACID BOILING IN THE FIRST PART, FOLLOWED BY SODA ASH INJECTION, AND POACHING IN THE LAST PART. THE UNIT WAS DESIGNED FOR A 10% NC SLURRY AND A RESIDENCE TIME OF 45 MINUTES.	165.0	95.0	70.0	DEC 77	MAR 79
5 78 4341	IMPROVED NITROCELLULOSE PURIFICATION PROCESS NO WORK WAS ACCOMPLISHED.	529.0	439.0	22.0	APR 79	JAN 80
5 77 4343	IMPROVED NITROCELLULOSE PROCESS CONTROL 27 SAMPLES OF NC WHICH WERE NITRATED AT ARRADCOM WERE ANALYZED FOR AZ USING HG NITROMETER METHOD THE TITRANOUS CHLORIDE TITRATION TECHNIQUE. VISCOSITIES OF 18 WOOD PULP SAMPLES WERE DETERMINED. THE NC WOOD PULP SAMPLES WERE EXAMINED MICROSCOPICALLY	302.0	117.0	161.0	JUL 78	MAR 79
5 78 4343	IMPROVED NITROCELLULOSE PROCESS CONTROL IN JUNE 1978, \$267,000 WAS WITHDRAWN FROM THIS PROJECT AND PROVIDED FOR M 78 6370. A NOMINAL \$15,000 WAS LEFT IN THIS FY 78 EFFORT. BASICALLY FOR COMPLETION OF THE FINAL REPORT. SEE PROJ 5 77 4343.	15.0		15.0	JUN 79	JUN 79
5 78 4349	MODERNIZATION OF PRESS LOADING FOR MEP PROJECTILES PROTOTYPE DESIGN WAS COMPLETED AND AN ADVERTISEMENT FOR BIDS WAS PREPARED.	250.0		16.0	JUN 80	JUN 80
5 77 4362	REHEAT OF LARGE CAL PROJECTILES TO ELIMINATE BASE SEPARATN A NEW THERMAL PANEL WAS INSTALLED IN THE CONTROLLED COOLING BAY. A PRELIMINARY CONTROLLED COOLING PROCESS WAS ESTABLISHED FOR THE 8-IN XM650. FURTHER TESTING WILL RESUME WHEN THE PROBE MACHINE IS INSTALLED TO REMOVE THE PIPING CAVITY.	400.0	28.8	297.5	APR 78	JUN 79

MANUFACTURING METHODS AND TECHNOLOGY PROGRAM
 S U M M A R Y P R O J E C T S T A T U S R E P O R T
 2ND SEMIANNUAL SUBMISSION CY 78 RES DRCHT-301

PROJ NO.	TITLE + STATUS	AUTHORIZED VALUES (\$000)	CONTRACT VALUES (\$000)	EXPENDED LABOR AND MATERIAL (\$000)	ORIGINAL PROJECTED COMPLETE DATE	PRESENT PROJECTED COMPLETE DATE
5 76 4302	ACCEPTANCE CRITERIA FOR CONTINUOUS SINGLE BASE PROPELLANT THE DYNAGUN TEST PROGRAM FOR THIS PROJECT HAS BEEN COMPLETED. THE FURNAL REPORT IS STILL IN PREPARATION.	440.0	317.0	123.0	JUN 77	MAR 79
5 76 4303	ACCEPTANCE OF CONTINUOUSLY PRODUCED BLACK POWDER INAAAP COMPLETED THEIR PORTION OF THE HMT. THE FUNCTIONAL TEST DEVICE WILL BE TRANSFERRED TO INAAAP DURING THE 2ND QTR FY79. INSTALLATION AND DEBUG OF THE TEST DEVICE WILL BE ACCOMPLISHED UNDER PROVEOUT OF 5 74 2084. FINAL REPORT IS BEING PREPARED.	337.0	157.7	165.3	APR 77	JUN 79
5 77 4303	ACCEPTANCE OF CONTINUOUSLY PRODUCED BLACK POWDER PRINCETON COMBUSTION HAS COMPLETED ITS WORK ON THE DEVELOPMENT OF THE FUNCTIONAL TEST DEVICE. THE REMAINING WORK WILL BE A COMPARISON OF LAB RESULTS WITH BALLISTIC TEST FIRINGS AND ADDITIONAL TESTING OF THE FLAME SPREAD DEVICE.	60.0	60.0		JUN 76	JUN 79
5 77 4304	SPIN TEST FOR ACCEPTANCE OF ROCKET GRAINS-STARG THE GRI WAS PRESENTED TO INDUSTRY 5 OCT 1978 AND PROPOSALS ARE EXPECTED 30 NOV 1978. THE CURRENT DESIGN APPROACH IS NOT ADAPUATE. THE DESIGN PROBLEMS ARE TO BE PRESENTED TO INDUSTRY FOR POSSIBLE SOLUTION.	300.0	84.0	41.0	JUN 79	JUN 79
5 78 4310	DMSD RECRYSTALLIZATION OF HMX/RDX STANDARD OPERATING PROCEDURE FOR THE PILOT IS BEING PREPARED. MINOR PIPING CHANGES AND CALIBRATION OF INSTRUMENTS PERFORMED ON PILOT PLANT.	196.0	170.0		AUG 79	AUG 79
5 79 4310	DMSD RECRYSTALLIZATION OF HMX/RDX THIS PROJECT WAS JUST FUNDED. NO STATUS REPORT WAS REQUIRED.	483.0				
5 76 4311	AUTO PROD EQUIP FOR LAP OF XM 692 MINE DISPENSING SYSTEM ASSEMBLY OF THE SIX MAJOR PIECES OF EQUIPMENT HAS PROGRESSED TO APPROXIMATELY 80% COMPLETE.	1,230.0	1,044.2	179.4	OCT 77	APR 79
5 77 4311	DEVELOP AUTOMATED PRODUCTION EQUIPMENT FOR XM 692 THE OVERLAY ASSEMBLY MACHINE HAS PASSED THE ACCEPTANCE TEST AT THE CONTRACTORS FACILITY AND IS READY FOR SHIPMENT TO LOUISIANA AAP.	1,073.0	793.1	150.2	AUG 78	AUG 79
5 79 4312	INJECTION MOLDING FOR PRODUCTION EXPLOSIVE LOADING THIS PROJECT WAS JUST FUNDED. NO STATUS REPORT WAS REQUIRED.	261.0				
5 78 4322	CHARACTERIZE DORMANCY EFFECT ON ELECTRONIC EQUIPMENT PROCEDURES DEVELOPED FOR DEACTIVATION, DORMANCY AND PERIODIC SURVEILLANCE ON CONTROL SYSTEM AT JAAP. DATA GATHERED THRU DEACTIVATION AND REVIEW OF PLANT ELECTRONIC SYSTEMS. EFFORT REVEALED WEAK, MARGINAL OR FAILURE SITUATIONS IN ELECTRONIC SYSTEM.	185.0	105.0	53.0	MAR 79	MAR 79

MANUFACTURING METHODS AND TECHNOLOGY PROGRAM
 SUMMARY PROJECT STATUS REPORT
 2ND SEMIANNUAL SUBMISSION CY 78 RCS DRGMT-301

PROJ NO.	TITLE + STATUS	AUTHOR- RIZED (\$000)	CONTRACT VALUES (\$000)	EXPENDED LABOR AND MATERIAL (\$000)	ORIGINAL	PRESENT
					PROJECTED COMPLETE DATE	PROJECTED COMPLETE DATE
5 77 4327	AUTOMATIC X-RAY INSPECTION SYSTEM-AXIS THE CONTRACTOR DEMONSTRATED THE FEASIBILITY OF AN AUTOMATED FILM READING SYSTEM, THE AMOUNT OF TIME REQUIRED TO DETECT THE FLAMS IS LENGTHY, HOWEVER, THIS SHOULD NOT IMPAIR THE DEVELOPMENT OF THE PROTOTYPE SYSTEM.	100.0	100.0		JUL 79	JAN 80
5 76 4337	ALTERNATE MATERIALS FOR CURING/MULDING PROCESS F/PAP MINES COMPLETED COMPATIBILITY TESTING OF ADAM COMPOUND AND ATC-3 ACCEL WITH PHX-MS PB STYPHINATE AND RDX, STARTED SIMILAR TESTING WITH ADAM PROPELLANT MIX. APPROACH OUTLINED FOR TESTING IMPACT OF ATC-3 ON PRESENT ADAM POTTING COMPOUND PROPERTIES.	504.0	190.0	109.7	AUG 78	MAR 79
5 76 4338	DEV AUTO PROCESS + PROTID EQUIP FOR LAP OF M483 15MM PROJ FABRICATION OF THE 30 PPM TAPE STIFFENER ASSEMBLY MACHINE IS CONTINUING. WORK ON THE 90 PPM ASSEMBLY MACHINE HAS BEEN STOPPED. THE GRENADE PREPACK WILL BE REDESIGNED TO HAVE A DUAL PURPOSE CAPABILITY SO IT CAN BE USED FOR THE M509 AND M483 PROJECTILE	758.6	654.6	63.4	MAR 79	MAY 80
5 77 4341	IMPROVED NITROCELLULOSE PURIFICATION PROCESS A DESIGN OF THE PROTOTYPE CONICELL UNIT WAS SELECTED. THE DESIGN WILL ALLOW ACID BOILING IN THE FIRST PART, FOLLOWED BY SODA ASH INJECTION, AND POACHING IN THE LAST PART. THE UNIT WAS DESIGNED FOR A 10% NC SLURRY AND A RESIDENCE TIME OF 45 MINUTES.	165.0	95.0	70.0	DEC 77	MAR 79
5 78 4341	IMPROVED NITROCELLULOSE PURIFICATION PROCESS NO WORK WAS ACCOMPLISHED.	529.0	439.0	22.0	APR 79	JAN 80
5 77 4343	IMPROVED NITROCELLULOSE PROCESS CONTROL 27 SAMPLES OF NC WHICH WERE NITRATED AT ARRADCOM WERE ANALYZED FOR NZ USING HG NITROMETER METHOD THE TITANOUS CHLORIDE TITRATION TECHNIQUE. VISCOSITIES OF 18 WOOD PULP SAMPLES WERE DETERMINED. THE NC WOOD PULP SAMPLES WERE EXAMINED MICROSCOPICALLY	302.0	117.0	161.0	JUL 78	MAR 79
5 78 4343	IMPROVED NITROCELLULOSE PROCESS CONTROL IN JUNE 1978, \$267,000 WAS WITHDRAWN FROM THIS PROJECT AND PROVIDED FOR M 78 6370. A NOMINAL \$15,000 WAS LEFT IN THIS FY 78 EFFORT, BASICALLY FOR COMPLETION OF THE FINAL REPORT. SEE PROJ 5 77 4343.	15.0		15.0	JUN 79	JUN 79
5 78 4349	MODERNIZATION OF PRESS LOADING FOR HEP PROJECTILES PROTOTYPE DESIGN WAS COMPLETED AND AN ADVERTISEMENT FOR BIDS WAS PREPARED.	250.0		16.0	JUN 80	JUN 80
5 77 4362	REHEAT OF LARGE CAL PROJECTILES TO ELIMINATE BARE SEPARAT A NEW THERMAL PANEL WAS INSTALLED IN THE CONTROLLED COOLING BAY. A PRELIMINARY CONTROLLED COOLING PROCESS WAS ESTABLISHED FOR THE 8-IN XM650. FURTHER TESTING WILL RESUME WHEN THE PROBE MACHINE IS INSTALLED TO REMOVE THE PIPING CAVITY.	400.0	28.8	297.5	APR 78	JUN 79

MANUFACTURING METHODS AND TECHNOLOGY PROGRAM
 S U M M A R Y P R O J E C T S T A T I S T I C S R E P O R T
 2ND SEMIANNUAL SUBMISSION CY 78 RCS DRCHT-301

PROJ NO.	TITLE + STATUS	AUTHORIZED (\$000)	CONTRACT VALUES (\$000)	EXPENDED LABOR AND MATERIAL (\$000)	ORIGINAL PROJECTED COMPLETE DATE	PRESENT PROJECTED COMPLETE DATE
5 77 4410	MFG TUNGSTEN PENETRATORS TO SHAPE BY TAPER SHAGING INADEQUATE COLD WORKING HAS BEEN ATTRIBUTED AS THE CAUSE OF BALLISTIC TEST FAILURE OF DOUBLE SNAGGED PENETRATORS. TOOLING HAS BEEN REDESIGNED TO GIVE MORE COLD WORKING.	397.0	249.0	131.3	MAR 78	JUN 79
5 77 4431	AUTOMATED EQUIPMENT FOR MORTAR IGNITION CARTRIDGES THE HEAD ASSEMBLY AND FINAL ASSEMBLY MODULES DESIGNS ARE COMPLETE. THE BODY ASSEMBLY MODULE DESIGN IS NEAR COMPLETION. THE TUBE TAPE WRAPPING, THE FLASH TUBE ASSEMBLY AND THE FINAL INSPECTION MODULES ARE BEING DESIGNED BY THE CONTRACTOR.	911.6	653.6	147.0	DEC 78	MAR 79
5 78 4431	AUTOMATED EQUIPMENT FOR MORTAR IGNITION CARTRIDGES THE CONTRACT WITH FMC CORPORATION WAS AMENDED BY ARRADCOM TO INCLUDE PHASE III AND IV OF THE ORIGINAL SCOPE OF WORK, SAFETY, OPERATING AND SUPPLY REQUIREMENTS WERE DEFINED, AND PERSONNEL/EQUIPMENT INTERFACES WERE DEVELOPED.	656.0	596.0		JUL 79	OCT 79
5 77 4444	BODY FOR M42/M46 GRENADE DAYRUN AND M8 ASSOCIATES APPROACHES HAVE BEEN SELECTED FOR THE NEXT PHASE OF THE PROJECT.	536.0	443.7	66.3	SEP 77	DEC 78
5 78 4444	BODY FOR M42/M46 GRENADE THE SCOPES OF WORK FOR F478 HAVE BEEN SENT TO PROCUREMENT.	626.0		32.2	JUN 79	JUN 79
5 79 4444	MNT-BODY FOR M42/ M46 GRENADE WORK HAS NOT BEEN INITIATED.	563.0			SEP 80	SEP 80
5 78 4447	NITROGUANIDINE PROCESS CONTROL ANALYTICAL SYSTEMS THREE METHODS FOR ANALYZING CRUDE CALCIUM CYANAMIDE WERE EVALUATED. WORK CONTINUED ON THE ASSAY OF THE CYANAMIDE CONCENTRATION IN THE GUANIDINE NITRATE REACTOR. TWO METHODS FOR ANALYZING SULFATE CONTENT OF THE ACID CONCENTRATORS WERE UNDERTAKEN.	220.0	26.0	150.0	JUL 79	JUL 79
5 78 4449	PROCESS IMPROVEMENT FOR COMPOSITION C-4 DESIGN WORK UNDER THIS PROJECT WILL NOT BEGIN UNTIL WORK NOW IN PROGRESS UNDER 5 77 4252 IS COMPLETED. ESTIMATED TIME OF TRANSFER OF WORK TO THIS PROJ IS APR, 79. TWO TRIAL LOTS OF COMP C-4 USING CLASS 1 + 5 RDX WAS MADE FOR LAAP EXTRUSION EVALUATION	1,000.0	35.0	4.1	OCT 79	NOV 80
5 78 4454	AUTO INSPECTION DEVICE OF EXPLOSIVE CNG IN SHELL-AIDEC CONTRACTOR PROPOSALS FOR TASK 1, AIDECs, IS BEING EVALUATED. THE CONTRACT WILL BE AWARDED DURING DEC 1978, TASK 2, AXIS, CONTRACT HAS BEEN AWARDED. THE CONTRACTOR HAS BEEN FURNISHED RADIOGRAPHS WITH TYPICAL M456 PROJECTILE PRODUCTION DEFECTS.	1,348.0	524.0	132.3	JUL 80	FEB 81

MANUFACTURING METHODS AND TECHNOLOGY PROGRAM
 SUMMARY PROJECT STATUS REPORT
 2ND SEMIANNUAL SUBMISSION CY 78 HCS DRCHMT-301

PROJ NO.	TITLE + STATUS	AUTHORIZED (\$000)	CONTRACT VALUES (\$000)	EXPENDED LABOR AND MATERIAL (\$000)	ORIGINAL PROJECTED COMPLETE DATE	PRESENT PROJECTED COMPLETE DATE
5 79 4454	AUTO INSPECTION DEVICE OF EXPLOSIVE CHARGE IN SHELL THIS PROJECT WAS JUST FUNDED, NO STATUS REPORT WAS REQUIRED.	628.0				
5 77 4457	MULTI-TOOLED IOWA DETONATOR LOADING MACHINE PRODUCTION WITH THE X4 LOADER WAS INITIATED IN OCT 1978. A 40 HR SUSTAINED RUN WAS CONDUCTED. THE X4 HAD AN AVAILABILITY OF APPROX 50% AND PRODUCED OVER 100K ACCEPTABLE DETONATORS DURING THE RUN. CURRENTLY, THE ONLY PROBLEM AREA IS PRESSURE SENSING.	641.0	616.0	25.0	OCT 77	JUN 79
5 79 4460	CONT MIXER=ILLUMINANT COMP ANAL + CONTROL SYSTEM THIS PROJECT WAS JUST FUNDED, NO STATUS REPORT WAS REQUIRED.	236.0				
5 77 4462	MODERNIZED FAD FOR MULTI-BASE PROPELLANTS BENCH STUDIES ON THE USE OF SODIUM BISULFITE SOLN TO REMOVE SOLVENT FROM FAD EXHAUST WERE CONDUCTED. SIEVE TRAY AND BUBBLE CAP TRAYS WERE EVALUATED. BENCH TESTS WERE ALSO CONDUCTED ON REMOVING AND DECOMPOSING NG IN THE DRYER EXHAUST AIR STREAM.	163.0	133.0	30.0	JAN 78	MAR 79
5 78 4462	MODERNIZED FAD FOR MULTI-BASE PROP FUNDS RELEASED TO ARRADCOM IN SEPT. 78. 10 MONTHS AFTER THE 1006 WAS CUT BY DARCOM, A FAD BLDG WAS DESIGNATED FOR USE TO HAVE A HAY MODIFIED FOR THE DRYING WORK. EOPT IS BEING REVIEWED FOR USE IN IMPROVING THE HEATING ARRANGEMENT IN A FAD BAY.	592.0	502.0	4.0	AUG 79	AUG 79
5 79 4462	MODERNIZED FAD FOR MULTI-BASE PROPELLANTS THIS PROJECT WAS JUST FUNDED, NO STATUS REPORT WAS REQUIRED.	528.0				
5 78 4466	VAL TNT, CYCLOTOL, AMATEX, OCTOL WITH PA MELT POUR FACIL A TEST PLAN FOR THE TNT SLURRY GENERATION PHASE HAS BEEN PREPARED, THESE TESTS WILL BE DELAYED UNTIL THE PILOT PLANT IS READY FOR OPERATION.	200.0		73.9	DEC 78	JUL 79
5 79 4466	VAL TNT, CYCLOTOL, OCTOL IN MELT-POUR FACILITY THIS PROJECT WAS JUST FUNDED, NO STATUS REPORT WAS REQUIRED.	461.0				
5 78 4469	AUTOMATED INSERTION OF GRENADE LAYERS. A CONTRACT HAS AWARDED TO MRC CORP. INERT M42/M46 GRENADES, M483 PROJECTILE METAL PARTS, AND A PALLET STOP STATION WERE DELIVERED TO THE CONTRACTOR, SOME INSPECTION DEVICES WERE EVALUATION.	502.0	286.0	110.0	APR 79	APR 79
5 79 4469	AUTO INSERTION OF GRENADE LAYERS THIS PROJECT WAS JUST FUNDED, NO STATUS REPORT WAS REQUIRED.	1,352.0				
5 78 4472	DEV EQUIP/ PROC FOR AUTO/MECH FAB OF CENTER CORE PROP BAG CONTRACT AWARDED TO NOVATRONICS, INC. CONTRACTOR STUDIES INAAAP HAND SEMING OPERATIONS. VISIT WAS MADE TO SEMING TOOL SHOW AND TO CONSULTANTS. CONTRACTOR PURCHASED MACHINE. REPORT ON CONCEPT FINDINGS TO BE MADE TO ARRADCOM IN JAN 1979.	215.0	148.0	57.5	JAN 79	JUL 79

S U M M A R Y P R O J E C T S T A T U S R E P O R T
2ND SEMIANNUAL SUBMISSION CY 78 RCS DRCHT-301

PROJ NO.	TITLE + STATUS	AUTHORIZED (\$000)	CONTRACT VALUES (\$000)	EXPENDED LABOR AND MATERIAL (\$000)	ORIGINAL PROJECTED COMPLETE DATE	PRESENT PROJECTED COMPLETE DATE
5 79 4472	DEV OF EQUIP/PROC FAUTO/MECH FAB OF CTR CORE PROP BAGS THIS PROJECT WAS JUST FUNDED, NO STATUS REPORT WAS REQUIRED.	49.0				
5 79 4474	DEHUMIDIFIED AIR FOR DRYING SINGLE-RAISE PROPELLANT THIS PROJECT WAS JUST FUNDED, NO STATUS REPORT WAS REQUIRED.	350.0				
5 77 4481	PYROLYSIS OF ARMY AMMUNITION PLANT SOLID WASTE A DATA BASE WAS ESTABLISHED TO IDENTIFY ALL OF THE COMPANIES THAT ARE INVOLVED IN PYROLYSIS TECHNOLOGY. THE TRM REPORT INDICATED FIVE PROMISING PROCESSES FOR PRODUCING A LIQUID FUEL FROM EXPLOSIVE CONTAMINATED WASTE OF WHICH ONLY THREE ARE ACCEPTABLE	100.0	10.9	88.3	DEC 77	MAR 81
5 79 4481	PYROLYSIS OF ARMY AMMUNITION PLANT SOLID WASTE THIS PROJECT WAS JUST FUNDED, NO STATUS REPORT WAS REQUIRED.	376.0				
5 79 4493	DESIGN PARAMETERS FOR LARGE-SCALE PROCESS VESSELS THIS PROJECT WAS JUST FUNDED, NO STATUS REPORT WAS REQUIRED.	247.0				
5 78 4498	DEVELOP CONCEPTS FR CONSOL + AUTO ASSY OF SMALL MINES 3 POURINGS HAVE BEEN MADE WITH THE XM74 CASE ASSEMBLY, FUNNEL, AND EXPLOSIVE AT VARIOUS TEMPERATURES. EACH CAST WAS WITHIN SPECS. IOMA HAS BEGUN FEASIBILITY STUDY OF AUTOMATING AT/AV MINE LAP.	325.0	130.0	25.2	DEC 80	DEC 80
5 79 4498	DEV METH FOR CONSOL + AUTO ASSY OF SMALL MINES THIS PROJECT WAS JUST FUNDED, NO STATUS REPORT WAS REQUIRED.	1,147.0				
5 78 4508	PROCESS IMPROVEMENT OF PRESSABLE RDX COMPOSITIONS WORK CONTINUED FROM 5 77 4252. COMP A-3 AND A-4 WERE PRODUCED USING N-OCTANE/AX ADDITION PROCESS. A-4 MET ALL PRODUCT SPECS. A-3 EXCEEDED BULK DENSITY REQUIREMENTS. COMP A-5 WAS PRODUCED USING CALL 1 RDX AND A CYCLOHEXANONE-STEARIC ACID SOLUTION.	300.0	241.0	12.1	NOV 78	NOV 79
5 79 4508	PROCESS IMPROVEMENT OF PRESSABLE RDX COMPOSITIONS THIS PROJECT WAS JUST FUNDED, NO STATUS REPORT WAS REQUIRED.	357.0				
5 76 6200	SMALL CALIBER AMMO PROCESS IMPROVEMENT PROGRAM PH III CONTRACT FOR PRODUCTION PLACED. TEN DAY INTEGRATION TEST RUN COMPLETED 15 NOVEMBER. ONE COMPLETE MODULE TO START PRODUCTION 1 JANUARY. PGCS INSTALLED AND BEING INTEGRATED. ONE L AND A SUBMODULE ACCEPTED AND RELEASED TO RAC FOR SCAMP INTEGRATION	1,300.0	298.0	987.0	AUG 76	NOV 78
5 77 6200	SMALL CALIBER AMMO PROCESS IMPROVEMENT PROGRAM G&M EVALUATION OF GFM MINISTEP PRESS COMPLETED. PRESS REFURBISHMENT NEARLY COMPLETE. TOOL DESIGN SOLIDIFIED. WATERBURY FARREL EVALUATION OF GFM ALISS PRESS COMPLETED. PRESS REFURBISHMENT NEAR COMPLETION. DIE DESIGN COMPLETED.	1,106.0	961.0	42.8	FEB 78	JUN 79

S U M M A R Y R E P O R T S T A T U S R E P O R T
 2ND SEMIANNUAL SUBMISSION CY 76 RCB DRCMT-301
 MANUFACTURING METHODS AND TECHNOLOGY PROGRAM

PROJ NO.	TITLE + STATUS	AUTHORIZED (\$000)	CONTRACT VALUES (\$000)	EXPENDED LABOR AND MATERIAL (\$000)	ORIGINAL PROJECTED COMPLETE DATE	PRESENT PROJECTED COMPLETE DATE
5 75 6211	SINTERED STEEL PREFORMS FOR WORKING INTO FRAG SHELL BODIES A TECHNICAL REPORT IS BEING PREPARED.	230.0	189.9	189.9	DEC 77	JUN 79
5 76 6472	APPLN OF ALT PROCES FOR FAB OF PRECIS METAL PARTS FOR MTEUZE PROCESS PARAMETERS TO MFG PINIONS BY AN ACCEPTABLE ALTERNATE PROCESS WERE TENTATIVELY ESTABLISHED. EXTRUSIONS WERE MADE IAW THOSE PARAMETERS. UPON COMPLETION OF THE DRAWING OPERATION, THE STOCK WILL BE SUBMITTED TO THE GOVT FOR EVALUATION.	400.0	346.0	13.2	FEB 78	SEP 79
5 77 6494	NEW CONCEPTS FOR MFR AND INSPECT OF 20MM 25MM 30MM AMMO SEE DESCRIPTION IN 5 76 6494.	1,300.0	1,204.0	94.0	AUG 79	JAN 80
5 75 6494	MANUFACTURE AND INSPECTION OF CAL.50, 20MM, AND 30MM AMMO LLAAP SOM DECREASED TO HEI CHARGING ONLY TO STAY WITHIN AVAILABLE FUNDS. AAI PROJECTILE FEEDER DESIGN APPROVED. SIX TRACE DETECTORS ADDED TO BALLISTIC TEST SUBMODULE.	3,760.0	2,434.0	1,317.0	DEC 76	JAN 80
5 76 6494	MANUFACTURE AND INSPECTION OF CAL.50, 20MM, AND 30MM AMMO LLAAP SOM DECREASED TO HEI CHARGING ONLY TO STAY WITHIN AVAILABLE FUNDS. AAI PROJECTILE FEEDER DESIGN APPROVED. SIX TRACE DETECTORS ADDED TO BALLISTIC TEST SUBMODULE.	1,200.0	980.0	220.0	DEC 77	JAN 80
5 77 6494	NEW CONCEPTS FOR MFR AND INSPECT OF 20MM 25MM 30MM AMMO SEE DESCRIPTION IN 5 76 6494.	2,220.0	1,565.0	643.5	JUN 79	JAN 80
5 76 6557	CONTINUOUS PROPELLANT DRYING SALT COATING AND GLAZING. MOTOR FOR FEED SYSTEM CENTRIFUGE INSTALLED. CONTROL PANELS BEING INSTALLED. FIRE PROT SYS 90PCT COMP. PLANS FOR EVAL MIRD FLUID BED DRYER COMPLETE. WOLVERINE BELT DRYER DESIGN BEING CHECKED. SAFETY SUBMISSION FOR WOLVERINE DRYING SYSTEM APPROVED.	734.0	683.0	51.0	DEC 76	MAR 80
5 75 6558	CAM-ADAPTATION OF AUTOMATIC DYNAMIC/STATIC FUZE REGULATION THIS PROGRAM HAS BEEN COMPLETED. THE EVALUATION REPORT REVEALED DESIGN REFINEMENTS ARE NECESSARY BEFORE THE EQUIP CAN BE UTILIZED IN PRODUCTION. THE CONTRACTOR IS PROCEEDING TO ACCOMPLISH THE REQUIRED WORK WITHIN THE REMAINING CONTRACT FUNDS.	315.0	68.6	212.7	MAR 76	JUL 79
5 74 6571	ENGR SUPPORT OF MORTAR AMMO MPTS MODERNIZATION THE 60MM LETHALITY TEST IS COMPLETED. MATERIALS JUDGED EQUIVALENT. FURTHER TESTS TO BE MADE ON CHEAPER MATERIALS. COST REPORT ON 81MM EXPECTED NEXT PERIOD. MICROSTRUCTURE AND MATERIAL PROPERTIES TESTS COMPLETED. RESULTS BEING EVALUATED.	970.0	512.0	454.0	DEC 76	APR 79
5 76 6596	BALL PROPELLANT PILOT PLANT STUDIES WORK ON THIS PROJECT HAS BEEN COMPLETED AND THE FINAL REPORT IS BEING PREPARED. FOLLOW-ON PROJECTS 5 76596 AND 5 78 6596 CONTINUE THE MFR BALL PROPELLANT PILOT PLANT STUDIES.	1,230.0	1,130.0	99.0	OCT 78	JUN 79

S U M M A R Y P R O J E C T S T A T I S T I C S R E P O R T
2ND SEMIANNUAL SUBMISSION CY 78 RCS DRCHT-301

PROJ NO.	TITLE + STATUS	AUTHORIZED (\$000)	CONTRACT VALUES (\$000)	EXPENDED LABOR AND MATERIAL (\$000)	ORIGINAL PROJECTED COMPLETE DATE	PRESENT PROJECTED COMPLETE DATE
5 77 6596	BALL PROPELLANT PILOT PLANT STUDIES THE SOPs FOR THE THREE BATCH STILLs WERE REVISED AS DIRECTED BY OPERATIONAL CHANGES MADE FOR SAFETY REASONS. A STATISTICAL PERFORMANCE ANALYSIS OF 16 PRODUCTION STILLs OF 5000 GALLONS WORKING VOLUME WAS CONDUCTED. TRAINING IS IN PROGRESS.	1,095.0	894.0	93.0	JUL 78	AUG 79
5 78 6596	BALL PROPELLANT PILOT PLANT STUDIES A HAZARD ANALYSIS ON THE BATCH SYSTEM WAS CONDUCTED. EQUIPMENT WAS RECEIVED, AND EQUIPMENT INSTALLATION IS SCHEDULED TO BEGIN IN MARCH 1979. A PROJECT COST GROWTH OF \$534K HAS BEEN IDENTIFIED, AND A REQUEST FOR A FUNDING INCREASE HAS BEEN MADE.	1,084.0	984.0	48.0	JAN 79	JUL 81
5 76 6599	2ND GENER ELECTROPTIC PROJ. CAVITY INS EQ FOR 155-175MM PROJOS A GFE TV CAMERA WAS DELIVERED TO THE CONTRACTOR. THE PROBLEMS ASSOCIATED WITH THE AC POWER INPUT, LIGHT CONTROL CIRCUITS AND ISOLATION TRANSFORMER HAVE BEEN RESOLVED. ARADCOM PERSONNEL VISITED THE CONTRACTORS PLAN TO WITNESS AN EQUIP. PERFORMANCE TEST	133.0	125.5	7.5	SEP 77	FEB 79
5 76 6628	AUTOMATED INSPECT. OF M.T. FUZE COMPONENTS-MOVE. PLATES- NO WORK ACCOMPLISHED DURING THIS REPORTING PERIOD.	250.0	198.6	43.4	JAN 77	MAR 80
5 76 6632	AUTO INSPECTION DEVICES FOR ART PROJECTILES IN MOD PLANTS THE COMPANY DEVELOPING THE HOT FURGING DIMENSIONAL SYSTEM IS GOING OUT OF BUSINESS. ALL THE WORK ACCOMPLISHED TO DATE IS BEING SHIPPED TO LAMP WHERE THICKOL WILL COMPLETE THE PROJECT. THE PROJECT WORK IS 90 PERCENT COMPLETE.	367.0	263.1	83.9	SEP 77	APR 79
5 77 6632	AUTO INSPECTION DEVICES FOR ART PROJECTILES IN MOD PLANTS CHANGES HAVE BEEN MADE TO THE ORIGINAL CONCEPT OF EDDY CURRENT INSPECTION SYSTEM FOR THE 155MM PROJECTILE BASE AND OGIVE. THESE CHANGES ARE EXPECTED TO IMPROVE THE RELIABILITY OF THE SYSTEM. THE ORIGINAL DELIVERY DATE HAS SLIPPED TWO MONTHS.	589.0	291.0	60.0	SEP 78	JUN 79
5 76 6634	MFG DU ALLOYS FOR LARGE CALIBER ARMOR DEFEATING PROJOS RECYCLING MATERIALS SIMULATING A STEADY STATE CONDITION HAS BEEN SUCCESSFULLY DEMONSTRATED.	500.0	403.0	96.5	AUG 77	MAR 79
5 77 6634	MFG DU ALLOYS FOR LARGE CALIBER ARMOR DEFEATING PROJOS BUTRESS THREADS HAVE BEEN SUCCESSFULLY ROLLED ON STABALLOY SPECIMENS.	707.0	240.6	481.7	JAN 78	MAY 79
5 78 6634	MFG DU ALLOYS FOR LARGE CALIBER ARMOR DEFEATING PROJECTILE APPROXIMATELY 40 INGOTS WERE CAST AND ROLLED TO 1.4 INCH DIAMETER. NO PROBLEMS HAVE BEEN ENCOUNTERED.	400.0	240.0	21.8	FEB 79	APR 79

SUMMARY PROJECT STATUS REPORT
2ND SEMIANNUAL SUBMISSION CY 78 RCS DRCHT-301

PROJ NO.	TITLE + STATUS	AUTHORIZED (\$000)	CONTRACT VALUES (\$000)	EXPENDED LABOR AND MATERIAL (\$000)	ORIGINAL PROJECTED COMPLETE DATE	PRESENT PROJECTED COMPLETE DATE
5 79 6634	MFG PROC FOR DU ALLOYS-LARGE CALIBER ARMOR DEFEATING PROJ THIS PROJECT WAS JUST FUNDED, NO STATUS REPORT WAS REQUIRED.	542.0				
5 76 6640	PROD CONTROL/OA OF SHAPED CHG LINERS BY AUTO X-RAY ANAL SPECIAL EMPHASIS WILL BE GIVEN TO EXAMINATION OF THE DUCTILE-BRITTLE TRANSITION REGION AND THE GROWTH RATE OF PERTURBATIONS IN THE JET DIAMETER. A RADIOGRAPHY EXPERT REVIEWED THE QUALITY OF THE JET MFG. PROCESS. HIS COMMENTS ARE EXPECTED IN JAN 1979.	133.0	55.8	77.2	DEC 76	FEB 79
5 77 6640	PROD CONTROL/OA OF SHAPED CHG LINERS BY AUTO X-RAY ANAL THE CONTRACTOR SHIPPED 200 SHEAR SPUN LINERS TO ARADCOM FOR TESTING. INFORMAL DISCUSSION WITH CHC-MATERIAL TO PRECISION MACHINE THE LINERS HAVE BEEN HELD. CURRENTLY, THE SCO PROCUREMENT SCOPE OF WORK FOR THE PRECISION MACHINING IS BEING FINALIZED.	165.0	66.9	75.6	JUN 76	SEP 79
5 76 6642	INERTIA WELDED ROTATING BANDS FOR PROJECTILE RODDIES, THE FINAL REPORT IS BEING REVISED BY CHAMBERLAIN MANUF, CO, FOR FINAL SUBMISSION.	447.0	275.0	131.0	FEB 77	JAN 79
5 78 6654	NOT FOR QC IN MFG OF ADVANCED FRAGMENTING STEEL SHELLS A TWO PHASE CONTRACT WAS AWARDED, THE FIRST PHASE IS EXPECTED TO DEVELOP A TECHNIQUE TO OVERCOME THE SIGNAL LAUNCHING FAILURE, PHASE II, THE FAR, OF INSPECTION SYSTEM WILL COMMENCE UPON SUCCESSFUL COMPLETION OF PHASE I.	590.0	540.0	14.7	JAN 80	JAN 80
5 77 6676	EVALUATION OF ACQUAQUENCH UNDER PRODUCTION CONDITIONS 155MM M107 AND 155MM M483 PROJECTILES WERE UNSUCCESSFULLY QUENCHED IN HOUGHTON 251 AQUA QUENCH, SAMPLES HAVE BEEN SENT TO TENACOL FOR EVALUATION AGAINST THEIR POLYMER QUENCH FLUID.	300.0	275.6	24.2	MAR 76	JUN 79
5 79 6681	PROCESS PARAMETERS FOR PRODUCTION FORMING OF PROJECTILES A CONTRACT HAS BEEN LET TO ITTRI FOR SQUEEZE CASTING.	600.0	167.3	19.3	JUN 79	JUN 79
5 79 6682	SIMULATION OF AMMUNITION PRODUCTION LINES THIS PROJECT WAS JUST FUNDED, NO STATUS REPORT WAS REQUIRED.	170.0				
5 77 6683	PRODUCTION OF TUNGSTEN BASE ALLOY PENETRATORS FOR AP MUNIT A STATISTICAL ANALYSIS OF 35 VARIABLES HAS BEEN COMPLETED FOR THE KENAMETAL SERIES 300 POWDER, THE RESULTS OF THIS ANALYSIS HAVE ALREADY IMPACTED THE PRODUCTION OF M735 CORES.	500.0	275.0	156.6	APR 76	MAY 79
5 76 6683	PRODUCTION OF TUNGSTEN BASE ALLOY PENETRATORS FOR AP MUNIT FY78 SCOPE OF WORK HAS BEEN REORGANIZED.	527.0	330.0	36.2	AUG 79	DEC 79

S U M M A R Y P R O J E C T S T A T U S R E P O R T
2ND SEMIANNUAL SUBMISSION CY 78 RCS DRGNT-301

PROJ NO.	TITLE + STATUS	AUTHORIZED (\$000)	CONTRACT VALUES (\$000)	EXPENDED LABOR AND MATERIAL (\$000)	ORIGINAL PROJECTED COMPLETE DATE	PRESENT PROJECTED COMPLETE DATE
5 78 6693	BALL PROPELLANT DETERGENT COATING-CAM RELATED CHARACTERIZATION OF THE DRP-H2O EMULSION AND RATE OF EMULSION OF DRP BY BALL PROPLT WAS COMPLTD. CAREFUL MEASRMT OF DRP-H2O EMUL INGREDIENTS REFD. TEMP AND AGIT SPD NOT CRITICAL. EMUL CHARACTRCS ALSO NOT CRITICAL. HENCE FEASIBILITY STUDY PHASE IS SIMPLIF	167.0	40.0	117.2	AUG 80	MAY 79
5 79 6693	BALL PROPELLANT DETERGENT COATING-CAM RELATED THIS PROJECT WAS JUST FUNDED. NO STATUS REPORT WAS REQUIRED.	171.0				
5 77 6716	MATH MODEL-FORM OPERATIONS- CURRENT + FUTURE ARTY MP DESIGN CONFIRMATION TESTS OF THE DRAWING MODEL ARE CURRENTLY UNDERWAY.	295.0	149.7	93.5	MAR 78	APR 79
5 79 6716	DEV OF COMPT-AIDED MODELING OF FORMING OPN P/ARTY HPTS DSGN THIS PROJECT WAS JUST FUNDED. NO STATUS REPORT WAS REQUIRED.	306.0				
5 78 6725	AUTOMATED INERTIA HANDING MACHINE FOR ARTILLERY MUNITIONS THE CONTRACTOR HAS PLACED ORDERS FOR TEST INSTRUMENTATION DEVICES A DATA ACQUISITION SYSTEM IS BEING DESIGNED.	325.0	249.8	21.0	APR 80	APP 80
5 78 6736	TECHNOL READINESS ACCEL THRU COMPUTER INTEGRATED MFG CAD/CAM TWO CONTRACTS AWARDED FOR MANUFACTURING DATA PACKAGES FOR TYPICAL AMMUNITION PRODUCTION LINES. PACKAGES PROCESSED INTO AUTOMATED DATA BASE. COMPUTER SOFTWARE IS OPERATIONAL FOR DATA BASE MANAGEMENT WITH GROUP TECHNOLOGY CAPABILITY AND NC TAPE PREP.	100.0	31.0	34.3	NOV 78	JUN 79
5 79 6736	TECH READINESS ACCEL THRU COMPUTER INTEGRATED MFG-TRACIM THIS PROJECT WAS JUST FUNDED. NO STATUS REPORT WAS REQUIRED.	256.0				
5 78 6748	SCAMP POLLUTION ABATEMENT LAYOUTS RECEIVED AND APPROVED. THE PROCUREMENT PACKAGE FOR THE CONSTRUCTION AND INSTALLATION OF THE SYSTEM WAS SUBMITTED AS REVIEWED BY THE PROCUREMENT, LEGAL, AND POLICY STAFFS.	310.0		39.4	JAN 81	JAN 81
5 79 6748	SCAMP POLLUTION ABATEMENT THIS PROJECT WAS JUST FUNDED. NO STATUS REPORT WAS REQUIRED.	77.0				
5 78 6753	METHODS F ORIENTING AND FEEDING SMALL CAL AMMO INITIAL TOOLING AND EQUIPMENT DESIGN COMPLETED BY G. H. CARTRIDGE CASE STRESS RELIEF TEST METHODS INVESTIGATED. 18 INCH AND 36 INCH COILS TO BE COMPARED FOR BODY ANNEAL. TEST PROCEDURE FOR GRAIN SIZE EVALUATION BEING QUALIFIED.	400.0	322.0	35.0	MAR 79	MAR 79
5 76 6759	FFAS FAULTY TRANSFER-HOT FORMING PRESSES F/HORTAR AMMO A TRIAL RUN OF 11MM FORGINGS WAS CONDUCTED BY NATIONAL MACHINERY UTILIZING A NATIONAL 6-4 HOT FURNER. THE RESULTS OF THE TRIAL RUN ARE BEING DOCUMENTED IN A REPORT.	132.0	117.0	3.0	MAY 77	SEP 79

MANUFACTURING METHODS AND TECHNOLOGY PROGRAM
 S U M M A R Y P R O J E C T S T A T U S R E P O R T
 2ND SEMI-ANNUAL SUBMISSION CY 78 RCS DRGMT-301

PROJ NO.	TITLE + STATUS	AUTHORIZED (\$000)	CONTRACT VALUES (\$000)	EXPENDED LABOR AND MATERIAL (\$000)	ORIGINAL PROJECTED COMPLETE DATE	PRESENT PROJECTED COMPLETE DATE
5 78 6760	DRYING OF LOW DENSITY BALL PROPELLANT MICROWAVE DRYING OF GRANULAR MATS IN LOW MOISTURE REGIONS CONSIDERED MORE ADVANTAGE. SCOPE OF WORK FOR MICROWAVE DRYING TESTS IS BEING PREPARED. CONTRACT FOR 150 LB 420-MET LOW DENS BALL PROPELLANT AWARDED. 50 LB OF ORDER HAVE BEEN RECEIVED TO DATE.	118.0	19.8	67.5	AUG 81	JUL 79
5 79 6760	DRYING OF LOW DENSITY BALL PROPELLANT THIS PROJECT WAS JUST FUNDED. NO STATUS REPORT WAS REQUIRED.	101.0				
5 78 6774	MFG METHOD FOR APDS PROJECTILE (25MM) SOW FOR APDS PROJECTILE ASSEMBLY AND CRITERIA FOR QA PROVISIONS WERE SUBMITTED TO PROCUREMENT. IGCE INITIATED TO SUPPLEMENT PROCUREMENT PACKAGE.	300.0	150.0	47.2	NOV 79	NOV 79
5 79 6774	MANUFACTURING METHODS FOR APDS PROJECTILE-25MM-MICV THIS PROJECT WAS JUST FUNDED. NO STATUS REPORT WAS REQUIRED.	695.0				

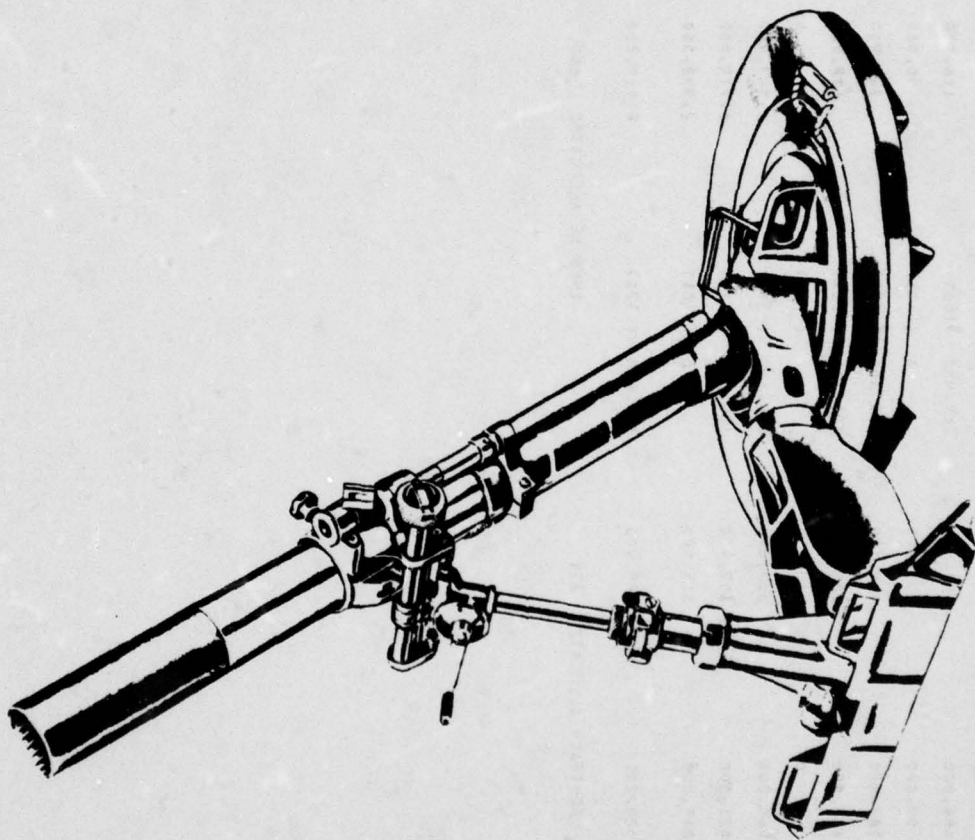

ARMAMENT R&D COMMAND
ARMAMENT MATERIEL READINESS COMMAND
(ARRADCOM, ARRCOM)
(WEAPONS)

A R R C O M - A R R A D C O M (WEAPONS)
CURRENT FUNDING STATUS, 2ND CY78

FISCAL YEAR	NO. OF PROJECTS	AUTHORIZED FUNDS (\$)	* CONTRACT FUNDS ALLOCATED (\$)	* CONTRACT FUNDS EXPENDED (\$)	* INHOUSE FUNDS ALLOCATED (\$)	* INHOUSE FUNDS EXPENDED (\$)
73	1	486,000	369,900	369,900 (100%)	116,100	82,800 (71%)
74	1	90,000	0	0 (0%)	90,000	90,000 (100%)
75	5	787,000	419,100	205,300 (48%)	367,900	334,000 (90%)
76	2	458,000	285,800	220,000 (76%)	172,200	123,900 (83%)
77	0	0	0	0 (0%)	0	0 (0%)
77	27	4,960,200	1,612,800	486,100 (30%)	3,347,400	1,983,500 (59%)
78	23	3,021,000	1,305,400	102,200 (7%)	1,715,600	389,600 (22%)
79	22	3,218,000	316,000	0 (0%)	2,902,000	0 (0%)
TOTAL	81	13,020,200	4,309,000	1,385,500 (32%)	8,711,200	3,023,800 (34%)

AUTHORIZED FUNDING CONTRACT ALLOCATED 33%

INHOUSE ALLOCATED 66%

S U M M A R Y P R O J E C T S T A T U S R E P O R T
 2ND SEMI-ANNUAL SUBMISSION CY 78 HCS DRCHT-301

PROJ NO.	TITLE + STATUS	AUTHORIZED (\$000)	CONTRACT VALUES (\$000)	EXPENDED LABOR AND MATERIAL (\$000)	ORIGINAL PROJECTED COMPLETE DATE	PRESENT PROJECTED COMPLETE DATE
6 78 3901	MANUFACTURE OF FLUIDIC AMPLIFIERS BY COLD FORMING THE AMPLIFIER TOOLING CONTRACT WAS AWARDED ON 21 NOV 78. THE DRAWINGS WERE REVIEWED AND SCHEDULING WAS DISCUSSED WITH THE CONTRACTOR. AN REP IS BEING PREPARED TO PROVIDE FOR MANUFACTURING, BONDING, AND TESTING OF PARTS.	290.0	170.0	57.0	SFP 79	DEC 79
6 73 7087	APPLY OF HIGH FREQ. INDUCTION HEATING FOR HOT COIL SPRINGS SHIELDED CABLE WAS INSTALLED TO PREVENT HIGH FREQUENCY NOISE INTERFERENCE. PROJECT DELAYED 5 MONTHS.	486.0	369.9	82.8	JUL 75	SEP 79
6 77 7201	ARTILLERY WEAPON FIRING TEST SIMULATOR MTS SYSTEMS CORP HAS STARTED THE DESIGN OF THE SECOND SIMULATOR. THIS SIMULATOR WILL TEST THE M127, M140, M551, AND M60A2 GUN MOUNTS.	700.0	480.0	37.8	OCT 78	OCT 79
6 77 7213	HIGH SPEED CHROME PLATING TECHNIQUE A PLATING APPARATUS HAS BEEN DESIGNED, CONSTRUCTED AND TESTED TO SHOW THAT CYLINDER BORES CAN BE CHROMIUM PLATED WITH A MOVING ANODE. A FINAL REPORT HAS BEEN SUBMITTED BY THE CONTRACTOR. FURTHER WORK WILL CONTINUE AT WATERVLIET ARSENAL.	266.0	100.0	48.8	DEC 77	AUG 79
6 79 7213	HIGH SPEED CHROMIUM PLATING TECHNIQUE THIS PROJECT WAS JUST FUNDED. NO STATUS REPORT WAS REQUIRED.	199.0				
6 76 7241	IMPROVEMENT- MONING EQUIPMENT AND PROCEDURES. ADDITIONAL 400 TURES HAVE BEEN PROCESSED. MODIFICATION TO COOLANT SYSTEM WAS COMPLETED. GAGING UNIT IS PRESENTLY BEING MODIFIED. REFRIGERATION UNIT IS ALSO BEING REPLACED.	178.0	55.3	117.4	MAR 77	JUL 79
6 79 7246	SIMPLIFICATION OF BREECH RING MFR AND HANDLING THIS PROJECT WAS JUST FUNDED. NO STATUS REPORT WAS REQUIRED.	60.0				
6 75 7248	IMPROVED MFG CONTRL THROUGH DATA AUTOMATION-CAM RELATED. AUTOMATED SHOP DATA COLLECTION SYSTEM HAS BEEN SUCCESSFULLY IMPLEMENTED. FORTY TWO REMOTE REPORTING TERMINALS DEPLOYED THROUGHOUT THE WATERVLIET ARSENAL MANUFACTURING COMPLEX. SYSTEM IS UNDER LEASE CONTRACT WITH OPTION TO BUY.	172.0	105.0	63.2	APR 77	MAY 79
6 77 7313	SIMULATOR FOR PRODUCTION TESTS OF WEAPONS- CAM ONE-GOING TESTING ON THE 6-DOF SIMULATOR HAS DELAYED IMPLEMENTATION OF THE TURRET ADAPTER HARDWARE AND SOFTWARE. REMAINING WORK SHOULD BE ACCOMPLISHED WITHIN THE NEXT SIX MONTHS.	205.0	85.0	106.7	DEC 77	JUN 79
6 79 7317	OPTIMIZATION OF STEP THREAD TOOLING THIS PROJECT WAS JUST FUNDED. NO STATUS REPORT WAS REQUIRED.	75.0				

S U M M A R Y P R O J E C T S T A T U S R E P O R T
2ND SEMIANNUAL SUBMISSION CY 78 RCS DRGMT-301

ROJ NO.	TITLE + STATUS	AUTHOR- RIZED (\$000)	CONTRACT VALUES (\$000)	EXPENDED LABOR AND MATERIAL (\$000)	ORIGINAL PROJECTED COMPLETE DATE	PRESENT PROJECTED COMPLETE DATE
6 74 7332	MFG DATA FOR OPT ELEMENTS, TOOLS + MATERIALS-CAM RELATED NON-AVAILABILITY OF MINI COMPUTER SYSTEM CAUSED SLIPPAGE. SYSTEM IS BEING SERVICED. DATA WAS FORMATTED AND COMPILED FOR ENTRY INTO AUTOMATED DATA BASE FOR OPTICAL MANUFACTURING DATA.	90.0		90.0	DEC 74	MAR 79
6 75 7419	RECIPROCATING SCREEN MOLDING OF THERMOSETTING PLASTIC THE TEST COMPONENT MOLD HAS BEEN FABRICATED AND INITIAL TESTS TO DETERMINE IN-CAVITY PLASTIC FLOW PATTERNS HAVE BEEN COMPLETED. THE MOLD HAS BEEN INSTALLED IN A RECIPROCATING SCREEN THERMOSET INJECTION PRESS AND PROCESSING STUDIES HAVE BEEN INITIATED.	45.0		41.5	JUN 76	APR 79
6 75 7430	FIRE CONTROL MANUFACTURE MODERNIZATION PLAN TND AND ARRADCOM CODED 1200 FIRE CONTROL PARTS DRAWINGS USING MICLASS. IS BEING ANALYZED TO SEE IF ENGINEERING + PRODUCTION DATA IS ADEQUATE FOR DIFFERENT FIRE CONTROL SHAPES. IF OK, THEN FAMILIES OF PARTS WILL BE IDENTIFIED AND STANDARD ROUTINGS SE	300.0	125.0	161.5	JAN 76	JUN 79
6 79 7482	MODIFIED RIFLE RIFLING GENERATING MACHINE THIS PROJECT WAS JUST FUNDED. NO STATUS REPORT WAS REQUIRED.	136.0				
6 77 7485	APPLICATION OF CHEMICAL PROCESSES TO IMPROVE SURFACE FINISH FIVE INCH CYLINDRICAL GUN TUBES WERE ELECTROPLATED AT CURRENT DENSITIES OF 300, 500, AND 600 AMPS/SQUARE FOOT. ADDITIONAL FULL CHAMBER-PARTIAL ANODE STUDIES WILL BE CARRIED OUT PRIOR TO FULL TUBE PROCESSING.	309.0		105.0	FEB 78	SEP 80
6 75 7532	SINGLE DT CUTTING FOR METAL + PLASTIC OPTICS PNEUMO PRECISION INC., KEENE, NH IS FAB AN ULTRA PRECISION CURVE GENERATOR. CONTRACTOR AND GOVT PROBLEMS CONTINUE TO PREVENT DELIVERY OF THIS MACH. EVENTUALLY THE MACH MAY BE SENT TO MIRADCOM HIGH ENERGY LASER CENTER.	140.0	94.1	36.8	JUN 76	SEP 80
6 79 7555	DYNAMIC PRESSURIZATION STAND, SLIDE LOCK BREECH MECH THIS PROJECT WAS JUST FUNDED. NO STATUS REPORT WAS REQUIRED.	121.0				
6 76 7580	PILOT AUTO SHOP LOADING AND CONTROL SYSTEM: CAM INVENTORY PROCESSING REVISED INSPECTION REPORTING AND MATERIAL MOVEMENT REPORTING WAS IMPLEMENTED. WORK IN PROCESS INVENTORY ACCURACY IMPROVED. MATERIAL REQUIREMENTS AND CAPACITY PLANNING SPECS WERE COMPLETED AND SOFTWARE DEVELOPMENT INITIATED.	280.0	230.5	26.5	SEP 78	NOV 79
6 77 7588	ROTARY FORGE INTEGRATED PRODUCTION TECHNOLOGY AN OPTIMIZED QUENCHING CYCLE HAS BEEN DEVELOPED FOR THE M88 AND M198 TUBES. TOOLING DRAWINGS FOR FORGING THE 20 INCH HOLLOW INGOTS HAVE BEEN REVISED AND APPROVED. THE INTERNAL VOID PROBLEM HAS BEEN SOLVED.	260.0	5.7	189.4	DEC 78	DEC 79

3 U M H A R Y P R O J E C T S T A T U S R E P O R T
2ND SEMIANNUAL SUBMISSION CY 78 RCS DRCMT-301

PROJ NO.	TITLE + STATUS	AUTHORIZED (\$000)	CONTRACT VALUES (\$000)	EXPENDED LABOR AND MATERIAL (\$000)	ORIGINAL PROJECTED COMPLETE DATE	PRESENT PROJECTED COMPLETE DATE
6 75 7589	AUTO TARGETING SYS FOR PRODUCTION TEST OF AUTO WPN + AMMO ACCURAC ACROSTIC SYS WORKS IN ONE SHOT MODE ONLY. BURSTS STILL NOT ABLE TO SCORE. CONTROLLER DUE BACK TO MIA JAN. ENTIRE CONTR EXTENDED TO JUN 79 TO ENABLE SOFTWARE CKOUT AFTER CONTROLLER FIX. FUNDS DO NOT INCLUDE EXPERIMENTATION WITH LIGHT STS APPCH	130.0	95.0	31.0	SFP 76	MAR 79
6 79 7605	CHEMICALLY ROUNDED SAND FOR CLOSE TOLERANCE CASTING NO WORK COMPLETED. FUTURE WORK CALLS FOR THE PURCHASE OF A SMALL SAND MIXER AND PATTERN, PATTERN BOX, AND CORE BOX REWORK.	127.0	30.0		MAR 80	MAR 80
6 77 7614	APPLN OF RAPID PLATING BY ABRASIVE PARTICLE FLUM. THE FLUIDIZED BED METHOD WAS DROPPED IN FAVOR OF SLURRY BATH. TESTS WERE CARRIED OUT IN A HULL CELL WITH VARIOUS ABRASIVE PARTICLES. CONTRACTOR HAS SLIPPED IN COMPLETING THE WORK.	115.0	45.0	54.2	APR 78	MAR 79
6 77 7644	APPLICATION OF INTEGRAL COLOR ANODIZE FOR ALUMINUM MIBAL RECEIVERS ARE BEING PROCESSED IN THE STANDARD BATHS. TESTS ARE BEING CONDUCTED ON COATED PARTS. OTHER PROCESSES WILL BE EVALUATED WHEN THE TECHNICAL PARAMETERS HAVE BEEN ESTABLISHED.	75.0		30.2	APR 78	JUL 79
6 77 7649	COMPUTERIZED POWDER METALLURGY FORGING DESIGN-CAM COMPUTER GRAPHICS HAVE BEEN DEVISED FOR PREFORM DESIGN FOR THE BASIC RIB-BER SHAPES.	100.0	57.8	37.4	MAY 78	JUN 79
6 78 7649	COMPUTERIZED POWDER METALLURGY FORGING DESIGN-CAM THE FOLLOW-ON CONTRACT HAS BEEN LET.	102.0	87.2	2.5	AUG 79	SFP 79
6 77 7650	FAB-RUBBER END ITEM USING MICROWAVE EQPT THE CAPABILITY OF THE MICROWAVE OVEN TO CURE OBJECTS OF VARYING SHAPES, SYMMETRY AND SIZE WAS ESTABLISHED. THE PROCESS IS MOST USEFUL WITH CIRCULAR OR LARGE ITEMS WHICH CAN BE ACCOMMODATED IN THE CENTRAL PART OF THE OVEN. FIELD TESTS ARE IN PROGRESS.	60.0		41.5	JUN 78	JUN 79
6 77 7652	COOLANT-CHIP EJECTOR. MULTI-OPERATION TOLLING INVESTIGATION OF THE EJECTOR COUNTER-BORING TOOL DESIGN AND PERF WAS MADE AND THE REQUISITION FOR TOOLING WAS MODIFIED. ALTERNATIVE TOOLING SOURCES WERE ALSO INVESTIGATED.	65.0	40.0	19.1	AUG 78	JUN 79
6 77 7655	APPLICATION - THERMARC SPRAY NEAR COATINGS THERMALLY SPRAYED ALUMINUM BRONZE BOND STRENGTH VS. SURFACE PREPARATION AND BOND STRENGTH VS. METHOD OF THERMAL SPRAY WERE EVALUATED. ALSO, THE AFFECT OF COATING STRENGTH ON COATING BOND STRENGTH WAS EVALUATED FOR 2 COATING SYSTEMS.	70.0	49.9	28.0	MAR 78	MAR 79
6 78 7655	APPLICATION - THERMARC SPRAY NEAR COATINGS THERMALLY SPRAYED ALUMINUM BRONZE WAS EVALUATED.	62.0	50.0	1.1	AUG 78	AUG 79

MANUFACTURING METHODS AND TECHNOLOGY PROGRAM
 S U M M A R Y P R O J E C T S T A T U S R E P O R T
 2ND SEMIANNUAL SUBMISSION CY 78 MCS URCMT-301

PROJ NO.	TITLE + STATUS	AUTHOR- RIZED	CONTRACT VALUES (\$000)	EXPANDED LARGE AND MATERIAL (\$000)	ORIGINAL PROJECTED COMPLETE DATE	PRESENT PROJECTED COMPLETE DATE
6 77 7707	AUTOMATED PROCESS CONTROL FOR MACHINING =CAMI AN INITIAL TRIAL OF ON-SITE CALCULATIONS DEMONSTRATED THAT UNDER SOME CIRCUMSTANCES COST SAVINGS COULD BE ACHIEVED. THESE SAVINGS WERE ACHIEVED BY SELECTIVELY OPTIMIZING TIME AND COSTS IN A TURNING OPERATION. TURNING OPERATIONS EVALUATION INITIATED.	105.0	44.7	44.9	OCT 78	JUN 79
6 78 7710	INJECTION MOLDING OF RUBBER ORTURATOR PADS THE INJECTION PRESS HAS BEEN MODIFIED. WORK IS IN PROCESS TO DETERMINE WHAT MODIFICATIONS ARE NECESSARY TO CONVERT THE COMPRESSION MOLD FOR USE AS AN INJECTION MOLD. IN ADDITION, THE DEMO. COMPONENT IS UNDERGOING A REDESIGN THAT WILL REQUIRE CHANGES	77.0	7.4	7.4	JUL 79	DEC 79
6 77 7711	ELECTROPOLISHING PROCESS MODELS FOR SMALL BORE WEAPONS ELECTROPOLISHING WAS CARRIED OUT AS A FUNCTION OF TIME ON M-11 TUBES WITH A CURRENT DENSITY OF 2 AMPS/SQUARE INCH. IRON CONTENT INCREASES IN THE BATH=ITS EFFECT ON CUTTING RATE AND EFFICIENCY IS BEING INVESTIGATED.	75.0	58.0	58.0	FFH 78	SEP 79
6 77 7714	MULTI-MODE WEAPON= MOUNT IMPEDANCE SIMULATOR (CAM) A CONTRACT WAS AWARDED TO THE FRANKLIN INSTITUTE RESEARCH LABORATORY FOR DESIGN AND FABRICATION OF THE SIMULATOR, AN INITIAL DESIGN IS PRESENTLY BEING EVALUATED.	285.0	225.0	32.5	OCT 79	JUL 80
6 77 7715	APPLICATION OF CONTROLLED=FORCE MACHINING AN NYC TAPE WAS MODIFIED AND USED WITH THE MACOTECH ADAPTIVE CONTROL UNIT ON RIA'S CINCINNATI HYDROTEL MILLING MACHINE, UNSUCCESSFULLY. A NEW TAPE WAS PREPARED. MACHINE BREAKDOWN FOUND. REPAIR STARTED.	64.0	30.5	27.2	JUN 78	MAY 79
6 77 7716	PROTOTYPE PROD. LINE FOR PRESSURE PHOSPHATE COATINGS CHEMICAL REACTIONS WERE INVESTIGATED TO DETERMINE THE MANGANESE PHOSPHATE BATH PARAMETERS.	115.0	70.0	38.1	APR 78	MAR 79
6 78 7716	PROTOTYPE PROD. LINE FOR PRESSURE PHOSPHATE COATINGS CHEMICAL REACTIONS WERE INVESTIGATED TO DETERMINE THE MANGANESE PHOSPHATE BATH PARAMETERS.	77.0	50.0	4.0	DEC 79	DEC 79
6 77 7720	FABRICATION METHODS FOR 2 AND 3 WIRE MESH SPRINGS ADDITIONAL MESH SPRINGS WERE DESIGNED AND FABRICATED. DETAIL DRAFT DESCRIBING THE MODIFICATIONS AND TOOLING REQUIRED IN ORDER TO WIND MESH SPRINGS ON THE PRODUCTION COILS WAS COMPLETED.	50.0	47.0	47.0	JAN 78	MAR 78
6 77 7722	IMPLEMENTATION OF THE 8 INCH XM201 ON ROTARY FORGE LINE MECHANICAL PROPERTIES ARE BEING EVALUATED FROM ROTARY FORGED TUBES	248.0	41.3	157.6	MAY 78	MAY 79

MANUFACTURING METHODS AND TECHNOLOGY PROGRAM
 SUMMARY PROJECT STATUS REPORT
 2ND SEMI-ANNUAL SUBMISSION CY 78 RCS DRMT-301

PROJ NO.	TITLE + STATUS	AUTHORIZED (\$000)	CONTRACT VALUES (\$000)	EXPENDED LABOR AND MATERIAL (\$000)	ORIGINAL PROJECTED COMPLETE DATE	PRESENT PROJECTED COMPLETE DATE
6 79 7724	GROUP TECHNOLOGY OF WEAPON SYSTEMS THIS PROJECT WAS JUST FUNDED, NO STATUS REPORT WAS REQUIRED.	63.0				
6 77 7726	ROT FORGE INTEGR PDN TECH BY COLD + WARM FORG W/NEW PREFORMS PREFORMS FOR THE COLD/WARM FORGING OF M68 TUBES HAVE BEEN EXTRUDED. INSTRUMENTATION OF THE ROTARY FORGED HAS BEEN INITIATED.	592.0	226.0	241.9	MAY 79	AUG 79
6 78 7726	APPLICATION OF COLD AND WARM ROTARY FORGE A TOP FOR PROCUREMENT OF THE PREFORMS HAS BEEN INITIATED. TOOLING PARAMETERS ARE BEING REVIEWED.	110.0			SEP 79	SEP 79
6 79 7726	APPLICATION OF COLD AND WARM ROTARY FORGING THIS PROJECT WAS JUST FUNDED, NO STATUS REPORT WAS REQUIRED.	403.0				
6 77 7727	RECYCLING OF SCRAP GUN TUBES BY ROTARY FORGING THE COMPUTER PROGRAM WAS USED TO DETERMINE DIMENSIONS FOR PREFORMS. PREFORMS HAVE BEEN CUT, FORGED, AND MACHINED. TUBES ARE BEING INSPECTED.	244.0	9.3	133.3	AUG 78	JUL 79
6 74 7727	RECYCLING OF SCRAP GUN TUBES BY ROTARY FORGING THIS PROJECT WAS JUST FUNDED, NO STATUS REPORT WAS REQUIRED.	237.0				
6 79 7730	MANUFACTURE OF SPLIT RING BREECH SEALS THIS PROJECT WAS JUST FUNDED, NO STATUS REPORT WAS REQUIRED.	137.0				
6 77 7733	ELIMINATION OF EXTERIOR TUBE MACHINING PRIOR TO SWAGE AUTO. STRESS ANALYSIS WORK COMPLETED. MUZZLE CLAMPS DESIGNED AND FABRICATED. PROJECT DELAYED BECAUSE OF INABILITY TO GET ENTRY INTO PRODUCTION SWAGE MACHINE.	47.0	1.8	42.8	MAR 78	JUL 79
6 77 7741	IMPR INST/INSPECT ANGLE + LINEARITY OF F C INSTS ARRADCOM IS REVIEWING DECILG INC. INSTRUCTIONS FOR ASSEMBLY, ALIGNMENT AND TESTING OF THE BI-REFRINGENT ANGULAR ALIGNMENT SENSOR. ARRADCOM IS IN PROCESS OF DESIGNING THE ASSOCIATED ELECTRONICS. THE NEW SET WILL NOT USE OPTICAL COMPONENTS FOR ALIGNME	130.0	47.3	40.1	APR 78	OCT 79
6 78 7741	IMPR INST/INSPECT ANGLE + LINEARITY OF F C INSTS THE HARDWARE IS ON ORDER FOR READ-BOARDING THE PROTOTYPE BIREFRINGENT ANGULAR SENSOR TEST SET. IT WILL BE USED TO DETERMINE WHETHER CONTINUATION OF THE PROJECT WILL BE BENEFICIAL.	54.0		15.0	DEC 79	DEC 79
6 78 7741	APPLICATION OF ANTI-FOG CONDUCTIVE FILMS NO PROGRESS WAS MADE DURING THE LAST 6 MONTHS. RESULTS WITH TIN OXIDE AND INDIUM OXIDE COATINGS WILL BE COMPARED TO RESULTS WITH TITANIUM MONOXIDE. NOTE	70.0		62.7	FEB 79	AUG 79

AD-A068 038

ARMY INDUSTRIAL BASE ENGINEERING ACTIVITY ROCK ISLAND IL F/6 5/1
MANUFACTURING METHODS AND TECHNOLOGY PROGRAM PROJECT STATUS REP--ETC(U)
APR 79 H E WEIDNER, L S HANCOCK

UNCLASSIFIED

NL

2 OF 2
ADA
068038



END
DATE
FILMED
6-79
DDC

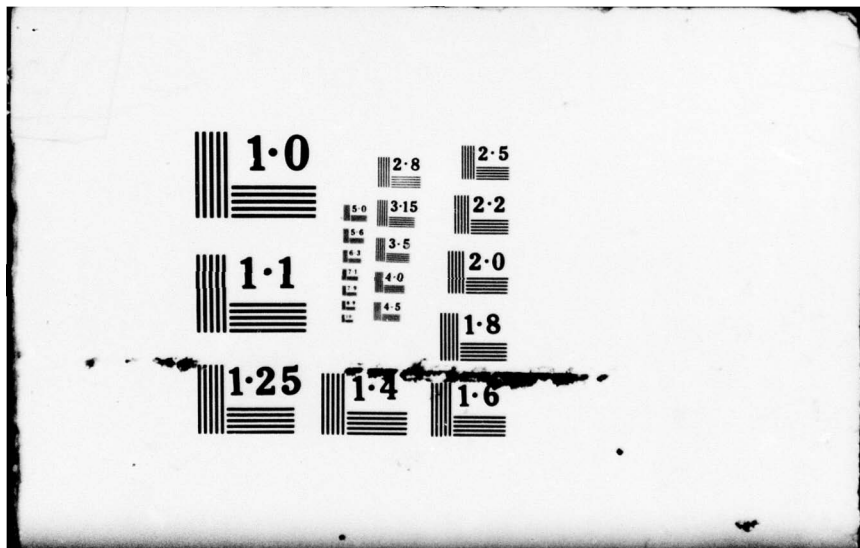

S U M M A R Y P R O J E C T S T A T U S R E P O R T
2ND SEMIANNUAL SUBMISSION CY 78 RCS DRCONT-301

MANUFACTURING METHODS AND TECHNOLOGY PROGRAM

PROJ NO.	TITLE + STATUS	AUTHORIZED (\$000)	CONTRACT VALUES (\$000)	EXPENDED LABOR AND MATERIAL (\$000)	ORIGINAL PROJECTED COMPLETE DATE	PRESENT PROJECTED COMPLETE DATE
6 77 7744	IMPROVED HFG PARAMETERS FOR OPTICS ARRADCOM OPTICS SHOP IS REVIEWING MIL SPEC MIL-0-13830 TO IDENTIFY REQUIREMENTS AND TEST PROCEDURES NEEDING REVISION. THIS RELATES TO A VARIETY OF INSTRUMENTS AND IS BASED ON CURRENT FIRE CONTROL PRODUCTION EXPERIENCE. MIL-13830 NEEDS UPDATING.	185.0	114.5	114.5	APR 78	AUG 79
6 77 7745	DIAMOND TOOL FABRICATION CAPABILITY A DIAMOND PELLET TOOL USABLE OVER A RANGE OF CONVEX RADII HAS BEEN DESIGNED. PELLETS TO BE USED WITH THIS TOOL ARE ON HAND. THREE LENSES OF VARYING REFRACTIVE INDICES AND RADII HAVE BEEN SELECTED TO BE USED FOR TOOL EVALUATION AND LENS BLANKS ON HAND	112.0	58.1	58.1	MAR 78	MAR 80
6 77 7746	IMPRV DURABILITY HIGH EFFICIENCY REFLECT FILMS SILVER FILM ADHERENCE TO GLASS WAS IMPROVED TO CONFORM TO MIL-SPEC FOR ALUMINUM REFLECTORS. THIS CHARACTERISTIC IS REPEATABLE WHEN RF SPUTTERING TECHNIQUES ARE USED. A 5 MONTH SLIPPAGE RESULTED FROM A DAMAGED RF SPUTTERING SYSTEM.	89.0	77.5	77.5	MAY 78	JUN 79
6 78 7802	ESTABLISH MCH TOOL PERFORMANCE SPECS SCOPE OF WORK COMPLETED AND CONTRACT AWARDED TO PACIFIC NORTHWEST LABORATORIES-BATTELLE. PROJECT GOALS REVIEWED AT OOD-MTAG MTG. PLENARY SESSION OF INTERNATIONAL MACH TOOL TASK FORCE ATTENDED. RIA MACHINE TOOL REPLACEMENT PLANS REVIEWED.	195.0	91.5	23.4	DEC 79	MAY 80
6 79 7802	ESTABLISH MACHINE TOOL PERFORMANCE SPECIFICATIONS FUNDS RECEIVED AND MILESTONE CHARTS COMPLETED.	205.0	146.0		JUN 81	JUN 81
6 78 7807	PROGRAMMED OPTICAL SURFACING EQUIP AND METHODOLOGY (CAM) PROCUREMENT SPECS FOR A MICROCOMPUTER CONTROLLED CURVE GENERATING/RADIUS TRUING MACHINE HAVE BEEN ESTABLISHED.	134.0	100.0	16.7	DEC 79	JUL 80
6 79 7807	PROGRAMMED OPTICAL SURFACING EQUIPMENT AND METHODOLOGY THIS PROJECT WAS JUST FUNDED. NO STATUS REPORT WAS REQUIRED.	134.0				
6 78 7808	LEAK DETECTION TECHNIQUES FOR SMALL SEALED FIRE CON ASSM A COMPREHENSIVE TEST PLAN WAS DEVELOPED. A COMMERCIAL HELIUM LEAK DETECTION SYSTEM WAS OBTAINED. CALIBRATION OF LEAK RATES WILL BE PERFORMED USING STANDARDS TRACEABLE TO NBS.	86.0	75.2	75.2	APR 79	SEP 79
6 77 7814	SYNTHETIC QUENCHANT FOR HEAT TREATING WEAPON COMPONENTS PROCUREMENT OF CONTRACTUAL SERVICES BEGAN.	67.0	10.0	50.1	FEB 78	AUG 79
6 78 7814	SYNTHETIC QUENCHANT FOR HEAT TREATING WEAPON COMPONENTS PROCUREMENT OF CONTRACTUAL SERVICES BEGAN.	51.0	45.0	1.8	JUN 79	FEB 80

MANUFACTURING METHODS AND TECHNOLOGY PROGRAM
 S U M M A R Y P R O J E C T S T A T U S R E P O R T
 2ND SEMIANNUAL SUBMISSION CY 78 HCS DRCHT-301

PROJ NO.	TITLE + STATUS	AUTHORIZED (\$000)	CONTRACT VALUES (\$000)	EXPENDED LABOR AND MATERIAL (\$000)	ORIGINAL PROJECTED COMPLETE DATE	PRESENT PROJECTED COMPLETE DATE
6 78 7825	ELIMINATION OF FACILITATING MONING OPERATIONS THE COGSDILL AIR-OPERATED BURNISHING TOOL HAS BEEN RECEIVED. THE ADAPTER REQUIRED TO USE THIS TOOL WITH THE RAPID BORE IS NEARLY COMPLETE. THE AVAILABILITY OF A RAPID BORE MAY CAUSE DELAYS.	133.0	1.4	12.4	JUN 79	OCT 79
6 78 7840	PORTABLE MULTI-DEGREE-OF-FREEDOM SIMULATOR SCOPE OF WORK HAS BEEN PREPARED FOR CONTRACTUAL EFFORT. DESIGN OF THE PROGRAMMABLE TRIANGULAR ACTUATOR MAY BE INCORPORATED OR NEW CONTRACTOR WILL BE CONSIDERED. CONTRACT AWARD FORECASTED BY MAY 79.	389.0	330.0	22.0	JUN 80	DEC 81
6 78 7844	ROOM TEMPERATURE PHOSPHATING COMPARISONS ARE BEING MADE OF COATINGS PRODUCED IN THE LAR BATH, SHOP BATH, AND CONVENTIONAL ZINC PHOS. BATH-DIFFICULTIES IN DETERMINING WHEN PROPER ADDITIONS OF SODIUM NITRITE HAVE BEEN MADE TO THE BATH HAS CAUSED SLIPPAGE.	37.0		25.4	SEP 78	FEB 79
6 78 7933	CENTRAL COOLANT SYSTEMS PRELIMINARY STUDY BEGUN. DESIGN FOR BUILDING 25 PARTLY COMPLETED. TECHNICAL SEARCH FOR COOLANT SYSTEM COMPONENT CONFIGURATION INITIATED.	58.0			SEP 79	SEP 79
6 77 7903	ANALYSIS FOR MODERNIZATION OF INDUSTRIAL OPERATIONS KEARNEY FIN KEPT APPROV AND GIVEN OK TO BEGIN PHASE 2. RIA ANALYSIS OF WORKLOAD COMP AND DATA FED TO KEARNEY FOR SIZING. RIA CONT IPF CONDITION ASSESSMENT TO IDENTIFY WHERE REPAIRS OR REPLACEMENTS SHOULD BE MADE. SEE 67A PROJECT FOR MORE DATA.	347.2	43.5	121.8	FEB 78	SEP 79
6 78 7923	ANALYSIS FOR MODERNIZATION OF INDUSTRIAL OPERATIONS ORIG INPUT DID NOT GIVE COMPL DATA, SYS AND PROC AND MAINT REV TASKS COMPL. PHYS MOD PLAN 0.80 COMPL AND CURRENT PLAN 0.60 COMPL. RIA EFFORT KEPT UP WITH CONTR MTGS AND REVIEWS. REMAINDER BEGINS AFTER KEARNEY EFFORT COMPLETED. FUNDS ADEQUATE.	433.0	304.3	28.0	JUN 79	FEB 80
6 79 7948	ESTABLISH CUTTING FLUID CONTROL SYSTEM FUNDS HAVE JUST BEEN RECEIVED. MILESTONE CHART COMPLETED.	150.0	100.0		FEB 80	FEB 80
6 79 7949	APPLICATION OF GROUP TECHNOLOGY TO RIA MFR-CAM-1ST INCH CONTRACT NEGOTIATIONS FOR TRAINING IN MICLASS ARE UNDERWAY. INSTALLATION OF MICLASS SYSTEM IS SCHEDULED FOR AUG 1979. AFTER THE SOFTWARE IS OPERATIONAL, SAMPLE PARTS WILL BE CODED AND APPLICATION PROGRAMS ANALYZED.	127.0	40.0		FEB 80	FEB 80
6 79 7963	GROUP TECH + CELLULAR MFR FOR FC COMPONENTS + ASSEMBLIES THIS PROJECT WAS JUST FUNDED. NO STATUS REPORT WAS REQUIRED.	188.0				

MANUFACTURING METHODS AND TECHNOLOGY PROGRAM
 S U M M A R Y P R O J E C T S T A T U S R E P O R T
 2ND SEMIANNUAL SUBMISSION CY 78 RCS DRCHT-301

PROJ NO.	TITLE + STATUS	AUTHO- RIZED	CONTRACT VALUES (\$000)	EXPANDED LABOR AND MATERIAL (\$000)	ORIGINAL PROJECTED COMPLETE DATE	PRESENT PROJECTED COMPLETE DATE
6 79 7665	DIFFERENTIAL SCATTEROMETRY FOR MICROFINISH SURFACES THIS PROJECT WAS JUST FUNDED, NO STATUS REPORT WAS REQUIRED.	100.0				
6 79 8004	CO-DEPOSITION OF SOLID LUBRICANTS DURING ANNOIZING THIS PROJECT WAS JUST FUNDED, NO STATUS REPORT WAS REQUIRED.	120.0				
6 79 8005	ESTABLISHMENT OF THE SPACE MECHANICAL PLATING PROCESS THIS PROJECT WAS JUST FUNDED, NO STATUS REPORT WAS REQUIRED.	150.0				
6 79 8010	PRODUCTION OF ACOUSTIC MICROWAVE FILTERS THIS PROJECT WAS JUST FUNDED, NO STATUS REPORT WAS REQUIRED.	233.0				
6 78 8017	POLLUTION ABATEMENT PROGRAM TWO COMMERCIAL NON-CYANIDE CADMIUM PLATING SYSTEMS HAVE BEEN PROCURED. PANELS PLATED BY THE NON-CYANIDE PROCESS EXCEEDED 96HR SALT SPRAY TEST AND MET ALL OTHER RIGHTS. A NON-CYANIDE COPPER PLATING SYSTEM WAS ALSO PREPARED.	82.0		55.0	APR 79	APR 79
6 79 8017	POLLUTION ABATEMENT PROGRAM NO WORK ACCOMPLISHED SINCE FUNDING ONLY RECENTLY ALLOCATED.	41.0			DEC 79	DEC 79
6 79 8025	ELECTRONIC PROFILE READOUT GAGE FOR POWDER CHAMBER CONTROLS THIS PROJECT WAS JUST FUNDED, NO STATUS REPORT WAS REQUIRED.	106.0				
6 78 8043	IMPROVED MACHINING PROCEDURES FOR DOWTEILS AN IN-DEPTH EVALUATION OF PRESENT MANUFACTURING SYSTEM IS IN PROCESS. AN INDUSTRIAL SURVEY IS BEING CONDUCTED TO DETERMINE AVAILABILITY OF ADAPTABLE EQUIPMENT.	100.0			JUN 79	JUN 79
6 78 8045	IMPROVED TURE STRAIGHTENING INQUIRIES HAVE BEEN SENT TO MANUFACTURERS.	125.0	30.0		MAR 80	MAR 80
6 78 8047	PASS THRU STEADY RESTS FOR TURE TURNING ENGINEERING STUDY BEING PERFORMED TO DETERMINE PRESSURES REQ'D TO SAFELY SUPPORT AND RETAIN VARIOUS GUN TUBES. SURVEY OF COMM. SYSTEMS ALSO BEING PURSUED.	130.0	15.0		SEP 80	SEP 80
6 78 8048	IMPRVD INSPECTION TECH F/INGOTS + PREFORMS F/ROTARY FORGING THE PROJECT MILESTONES HAVE BEEN ESTABLISHED, A CONTRACT IS SCHEDULED TO BE AWARDED IN MAY 1979.	113.0	31.0		SEP 80	SEP 80
6 78 8049	MANUFACTURING PROCESSES ENERGY CONSERVATION PROGRAM ENERGY CONSERVATION EQUIPMENT MFRS AND ENERGY CONSULTANT FIRMS WILL ME TO A PRESOLICITATION MEETING. AN ENERGY PROFILE OF THE M60, 135MM TANK GUN MANUFACTURING LINE WAS INITIATED.	100.0			DEC 79	DEC 79

MANUFACTURING METHODS AND TECHNOLOGY PROGRAM
 SUMMARY PROJECT STATUS REPORT
 2ND SEMI-ANNUAL SUBMISSION CY 78 RCB DRGNT-301

PROJ NO.	TITLE + STATUS	AUTHORIZED (\$000)	CONTRACT VALUES (\$000)	EXPENDED LABOR AND MATERIAL (\$000)	ORIGINAL PROJECTED COMPLETE DATE	PRESENT PROJECTED COMPLETE DATE
6 79 8107	CREEP FEED CRUSH FORM GRINDING THIS PROJECT WAS JUST FUNDED, NO STATUS REPORT WAS REQUIRED.	82.0				

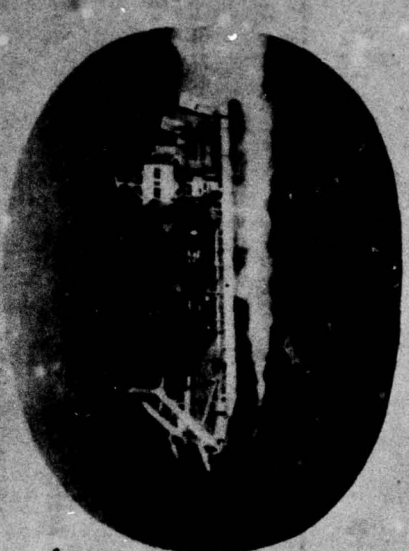

Fort Belvoir, Va.



100

MOBILITY EQUIPMENT RESEARCH AND DEVELOPMENT COMMAND
CURRENT FUNDING STATUS, 2ND CY78

FISCAL YEAR	NO. OF PROJECTS	AUTHORIZED FUNDS (\$)	CONTRACT FUNDS ALLOCATED (\$)	CONTRACT FUNDS EXPENDED (\$)	INHOUSE FUNDS ALLOCATED (\$)	INHOUSE FUNDS EXPENDED (\$)
76	1	250,000	70,000	70,000 (100%)	180,000	132,000 (73%)
77	0	0	0	0 (0%)	0	0 (0%)
77	2	700,000	634,900	204,600 (48%)	71,100	14,000 (20%)
78	8	1,737,000	1,326,000	479,000 (36%)	410,200	244,600 (59%)
79	11	2,731,000	700,000	0 (0%)	2,023,000	0 (0%)
TOTAL	22	5,424,000	2,739,700	833,600 (30%)	2,404,300	191,200 (14%)

AUTHORIZED FUNDING

CONTRACT ALLOCATED 51%

INHOUSE ALLOCATED 49%

MANUFACTURING METHODS AND TECHNOLOGY PROGRAM
 S U M M A R Y P R O J E C T S T A T U S R E P O R T
 2ND SEMI-ANNUAL SUBMISSION CY 78 RCS ORCNT-301

PROJ NO.	TITLE + STATUS	AUTHORIZED (\$000)	CONTRACT VALUES (\$000)	EXPENDED LABOR AND MATERIAL (\$000)	ORIGINAL PROJECTED COMPLETE DATE	PRESENT PROJECTED COMPLETE DATE
E 78 3532	MOLTEN SALT LI/CL BATTERY A LI-AL/FES CELL OF 340 AM WAS OP AT 450 DEG C. ENERGY DENS 2X Pb-ACID CELL. CYCLE LIFE OVER 1200 ACHIEVED ON 60 AM CELLS. EST COST FOR 10K BATT/YR IS \$192/AMH.	120.0	105.0	8.0	DEC 78	FEB 79
E 79 3532	MOLTEN SALT LI/CL BATTERY THIS WILL BE CONTINUATION OF PRIOR YEAR EFFORT. CONTRACT STILL TO BE LET.	295.0	280.0		AUG 80	AUG 80
E 78 3587	SLURRY ROCKET MOTOR EXPERIMENTAL BATCHES OF PROP MIX WERE TESTED FOR EFFECT OF ALUM OXIDE PURITY ON POT LIFE. HYDRATED ALUM OXIDE PRODUCED BEST RESULTS (3MR 4RMIN). PLASTICIZERS WERE ADDED TO EXTEND POT LIFE. 22 01-OCTYL-ADIPATE EXTENDED POT LIFE TO MORE THAN SIX HOURS.	210.0	200.0	10.0	AUG 79	OCT 79
E 78 3588	SLURRY MINE NEUTRALIZER LAUNCHER COST EFFECTIVE METHODS FOR PACKAGING LAUNCH TUBES DETERMINED. HURST PRESSURE TESTING RESULTS OF ROTH 4061 AND 4063 IN TEMPERatures 41E66 WERE GOOD AND COMPARED FAVORABLY WITH PREVIOUS THEORETICAL CALCULATIONS.	100.0	30.0	5.6	APR 79	APR 79
E 77 3592	IMPROVED GRAPHITE REINFORCEMENT THE CONTRACT PORTION OF THE WORK WAS COMPLETED AND SUMMARIZED IN A TECHNICAL REPORT. A CHEMICALLY MODIFIED GRAPHITE FIBER WAS DEVELOPED WHICH DISPLAYED SUPERIOR PROPERTIES TO ANY COMMERCIAL FIBER. PROPERTY GOALS WERE NOT ACHIEVED.	206.0	148.6	14.6	SEP 78	JUN 79
E 78 3604	SOLID STATE POWER SWITCH DELTA ELECTRONICS CONVERTED THE BRASSBOARD DESIGN INTO A PRODUCTION DESIGN. ALL SWITCH PARTS WILL BE ASSEMBLED ON A COMMON HEAT SINK. THE PACKAGE MUST THEN BE HERMETICALLY SEALED.	350.0	295.0	36.0	JUN 80	JUN 80
E 79 3604	SOLID STATE POWER SWITCH FOLLOW-ON TO ABOVE. DELTA ELECTRONICS WILL PRODUCE ENGINEER A POWER TRANSISTOR TO SWITCH 50 AMPS AT 50 KHZ AND 300 VOLTS. WILL INCLUDE WAFER PROCESSING, MOUNTING, HERMETIC SEALING AND TESTING.	85.0	55.0		JUN 81	JUN 81
E 78 3605	TRANSCALENT-HIGH POWER-TRANSISTOR SEE FOLLOW-ON PROJECT. FUNDS WILL BE COMBINED WITH FY79 FUNDS AND A CONTRACT LET TO RCA.	50.0		20.0	MAR 82	MAR 82
E 79 3605	TRANSCALENT-HIGH POWER-TRANSISTOR FOLLOW ON TO ABOVE. A CONTRACT WITH RCA IS IN ITS FINAL STAGES AND WILL SOON BE SIGNED. THE CONTRACTOR WILL DIFFUSE A SPURSE-LIKE EMITTER STRUCTURE ON THE TRANSISTOR WAFER. A SIMILAR EMITTER BALLAST RESISTOR WILL BE RETAINED IN ALIGNED DURING ASSEMBLY	483.0			MAR 82	MAR 82

MANUFACTURING METHODS AND TECHNOLOGY PROGRAM
 S U M M A R Y P R O J E C T S T A T U S R E P O R T
 2ND SEMI-ANNUAL SUBMISSION CY 78 RCS DRCT-301

PROJ NO.	TITLE + STATUS	AUTHOR- RIZED (\$000)	CONTRACT VALUES (\$000)	EXPANDED LARGE AND MATERIAL (\$000)	ORIGINAL	PREFEAT
					PROJECTED COMPLETE DATE	PROJECTED COMPLETE DATE
E 78 3606	250 AMP TRANSCALENT (HIGH POWER) RECTIFIER RCA EXAMINED THE RECTIFIER'S DESIGN FOR PROCESS CHANGES. METALLIZATION THICKNESS WILL BE VARIED FOR UNIFORM CURRENT DISTRIBUTION. THE PROCESS WILL DETERMINE THE THICKNESS NEEDED, APPLY METAL, AND CONFIRM, WILL ALSO LOOK AT ASSEMBLY AND TEST.	360.0	305.0	44.0	JUN 80	JUN 80
E 79 3606	250 AMP TRANSCALENT HIGH POWER RECTIFIER RCA WILL BUILD SAMPLE RECTIFIERS AFTER THE PROCESSES ARE DETERMINED ON THE FY78 PROJECT, RECTIFIERS MUST CARRY 250 AMPS AT 10 KHZ AND BLOCK 1600 VOLTS.	85.0	55.0		JUN 81	JUN 81
E 78 3613	VEHICLE-MOUNTED ROAD MINE DETECTOR SYSTEM ANTENNAS CONTRACTOR IS PERFORMING INVESTIGATIONS AND MAKING INQUIRIES TO INDUSTRY IN ORDER TO IDENTIFY POTENTIAL CANDIDATE ADVANCED TECHNIQUES OF MANUFACTURE.	195.0	162.8	30.0	JUN 80	JUN 80
E 79 3613	VEHICLE-MOUNTED ROAD MINE DETECTOR SYSTEM ANTENNAS EFFORT HAS NOT BEEN INITIATED.	163.0	91.0		JUN 80	JUN 80
E 79 3708	COATED FABRIC COLLAPSIBLE FUEL TANK- CIRCULAR SEAMLS WEAVING FUNDING JUST RECEIVED. FIRST STEP PLANNED IS A SURVEY OF POTENTIAL MFRS TO DETERMINE THEIR EXPERIENCE IN CIRCULAR SEAMLESS WEAVING. SURVEY WILL ALSO BE MADE OF POTENTIAL MFRS CAPABILITY IN COLLAPSIBLE FUEL TANK SIZE AND MATLS OF CONSTRUCTION.	97.0	37.0		AUG 79	AUG 79
E 79 3709	CONTINUOUS LENGTH FUEL HOSE EFFORT HAS NOT BEEN INITIATED.	245.0	190.0		SEP 81	SEP 81
E 78 3717	HIGH TEMPERATURE TURBINE NOZZLE FOR 10 KW POWER UNIT CONTRACT WAS AWARDED TO SOLAR TURBINES INTERNATIONAL FOR WORK UNDER PHASE 1 OF TOTAL PROGRAM. INITIAL INQUIRIES FOR MATERIALS HAS BEEN SENT OUT TO THE CERAMICS INDUSTRY UPON WHICH TO BASE THE SELECTION OF MATERIALS AND MANUFACTURING PROCESSES.	343.0	229.0	91.0	SEP 79	SEP 79
E 79 3743	COMPOSITE SPUN MATERIAL LAUNCHING BEAM FOR BRIDGES WORK HAS BEEN DELAYED TO AWAIT THE COMPLETION OF AN R&D PROJECT. CONTRACT DOCUMENTATION HAS BEEN COMPLETED. PLACEMENT OF THE CONTRACT IS PLANNED FOR JUNE.	420.0				
E 79 3745	ALUMINUM-GRAPHITE EPOXY SANDWICHED BRIDGE REINFORCEMENT RESEARCH AND DEVELOPMENT WORK NECESSARY FOR THE PERFORMANCE OF THIS PROJECT HAS NOT BEEN COMPLETED. REPROGRAMMING ACTION HAS BEEN INITIATED. FUNDS ARE TO BE REPROGRAMMED TO PMS E793783, E793782 AND E7937819	383.0				

MANUFACTURING METHODS AND TECHNOLOGY PROGRAM
 SUMMARY PROJECT STATUS REPORT
 2ND SEMIANNUAL SUBMISSION CY 78 HCS DRGCMT-301

PROJ NO.	TITLE + STATUS	AUTHORIZED (\$000)	CONTRACT VALUES (\$000)	EXPENDED LABOR AND MATERIAL (\$000)	ORIGINAL PROJECTED COMPLETE DATE	PRESENT PROJECTED COMPLETE DATE
E 77 3749	HYDRAULIC ROTOR ACTUATORS ACTUATORS ARE BEING MACHINED FOR FINAL ASSEMBLY. ADDITIONAL FUNDING IS BEING SOUGHT.	500.0	486.3		MAY 79	APR 79
E 79 3756	COMPOSITE MATERIAL GIRDER MODULES FOR BRIDGES IN LIEU OF R D RESULTS, THIS PROJECT IS CANCELLED. ACTION IS BEING TAKEN TO REPROGRAM THIS FUNDING TO PROJECTS E793761 AND E793763.	300.0				
E 79 3759	HEULAR CABLE REINFORCEMENT FOR MILITARY BRIDGES WORK ON THIS PROJECT CANNOT BE INITIATED UNTIL THE COMPLETION OF WORK ON A CURRENT MACT PROJECT, WHICH IS PROJECTED FOR LATE MARCH. A SLIPPAGE OF SIX MONTHS WILL RESULT.	175.0				
7 76 5504	PRODUCTION OF PHOSPHAZENE ELASTOMERS ***** DELINQUENT STATUS REPORT *****	250.0	70.0	132.0	SEP 77	DEC 78

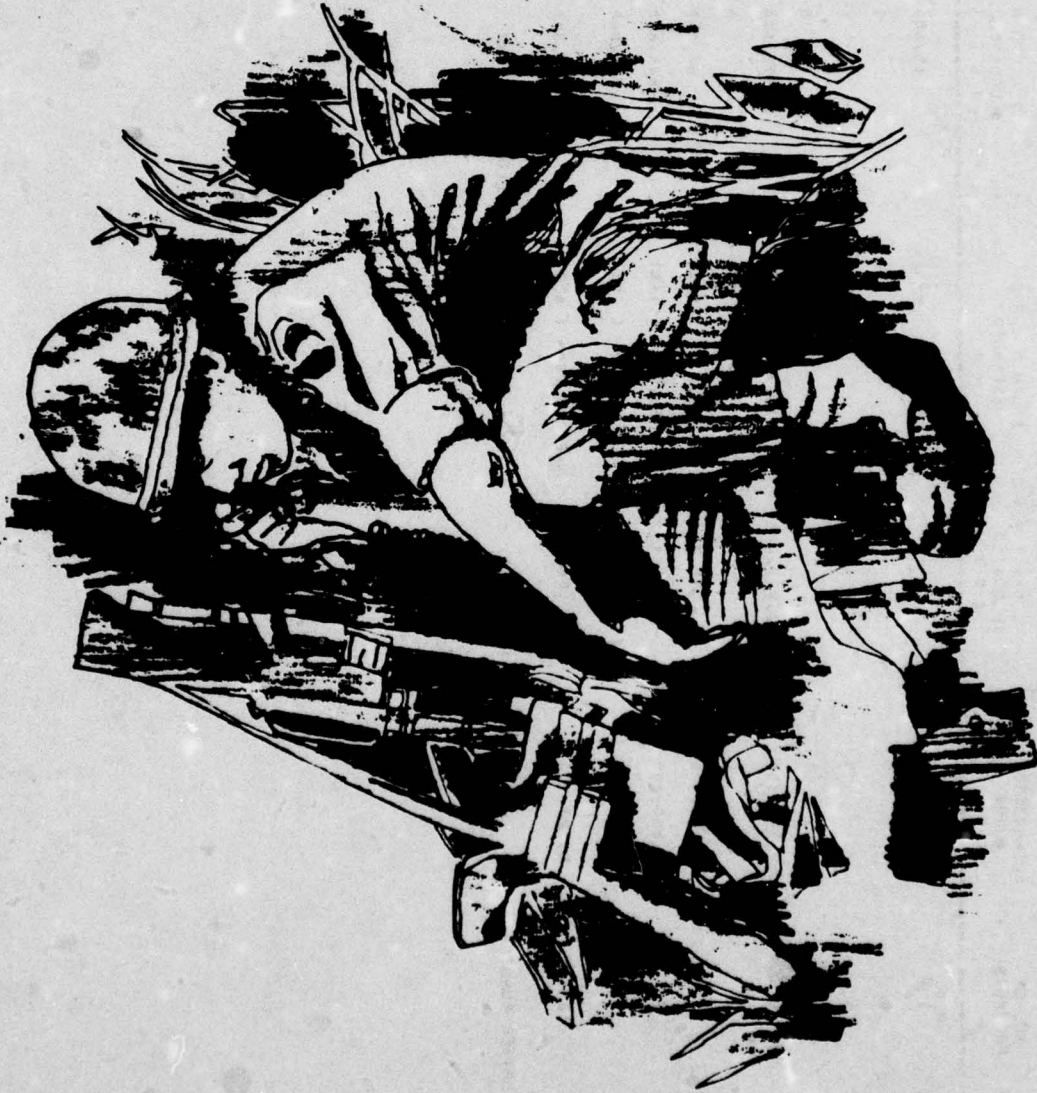

**COMMUNICATIONS R&D COMMAND
(CORADCOM)**

105

COMMUNICATIONS R + D COMMAND
CURRENT FUNDING STATUS, 2ND CY76

FISCAL YEAR	NO. OF PROJECTS	AUTHORIZED FUNDS (\$)	CONTRACT ALLOCATED (\$)	CONTRACT EXPENDED (\$)	IMMURSE ALLOCATED (\$)	IMMURSE EXPENDED (\$)
72	1	130,000	114,400	54,400 (47%)	15,600	16,000 (102%)
73	0	0	0	0 (0%)	0	0 (0%)
74	0	0	0	0 (0%)	0	0 (0%)
75	0	0	0	0 (0%)	0	0 (0%)
76	5	2,595,300	2,222,200	1,713,700 (77%)	371,100	310,900 (83%)
77	0	0	0	0 (0%)	0	0 (0%)
77	1	448,800	398,800	200,000 (50%)	50,000	31,300 (62%)
78	2	1,100,000	453,400	50,100 (11%)	646,600	24,300 (3%)
79	3	1,510,000	0	0 (0%)	1,510,000	24,000 (1%)
TOTAL	12	5,782,100	3,166,600	2,016,200 (63%)	2,593,300	406,500 (15%)

AUTHORIZED FUNDING CONTRACT ALLOCATED 55% IMMURSE ALLOCATED 84%

MANUFACTURING METHODS AND TECHNOLOGY PROGRAM
SUMMARY REPORT
2ND SEMIANNUAL SUBMISSION CY 78 RCS DRCMT-301

PROJ NO.	TITLE + STATUS	AUTHORIZED (\$000)	CONTRACT VALUES (\$000)	EXPENDED LABOR AND MATERIAL (\$000)	ORIGINAL PROJECTED COMPLETE DATE	PRESENT PROJECTED COMPLETE DATE
2 72 9025	MM+T FOR TEMP COMPENSATED MICROCIRCUIT CRYSTAL OSCILLATORS CTS KNIGHTS INC HAS EXPERIENCED TECHNICAL AND ADMINISTRATIVE PROBLEMS. CONTRACT TERMINATION WAS INITIATED BY CONTRACTING OFFICER ON 30 MAY 1978. ALL WORK HAS STOPPED. NEW TECHNIQUES AND MATERIALS HAVE OBSOLETE THE 6 YR OLD PROJECT.	130.0	114.4	16.0	APR 74	MAY 81
2 76 9679	NUMERICAL CONTROL LATHE LANGUAGE EVALUATION SEVENTEEN MAJOR LANGUAGES WERE INITIALLY SELECTED. ONE WAS WITHDRAWN. QUESTIONNAIRE COMPLETED BY LANGUAGE PROPONENTS. TEST PATTERNS DISTRIBUTED FOR PROGRAMMING. ELEVEN OF SIXTEEN LANGUAGES SUMMARIZED. TEN PARTS SELECTED FOR BENCHMARK TESTS.	395.0	195.1	155.9	OCT 79	DEC 79
2 76 9758	PROCESSES FOR METAL NITRIDE OXIDE SEMICONDUCTORS FOR BORAM WESTINGHOUSE HAS SUCCESSFULLY FABRICATED APPROX 25 PERCENT OF TOTAL MMOS CHIPS REQUIRED FOR BORAM. WAFER PROF TEST YIELDS OF 17 TO 22 PERCENT WERE OBTAINED. DELAYS RESULTED FROM DIFFICULTIES IN SCHEDULING THE MOUNTING AND PROCESSING OF CHIPS.	724.0	674.0	50.0	AUG 74	MAY 79
2 78 9773	COMPUTER AID FAPREP OF AUTO ANALOG CIRCUIT PROD TEST PROG THEORETICAL ANALYSIS OF BASIC ANALOG NETWORKS HAS BEEN COMPLETED. MODELS GENERATED TO DESCRIBE THESE NETWORKS. ANALYSIS OF ACTUAL NETWORKS, CHARACTERISTICS AND TEST TECHNIQUES WAS INITIATED. CONTRACT MODIFIED TO INCORPORATE ARMY AUTOMATED TEST EQUIP.	500.0	453.4	0.3	NOV 79	SEP 80
2 76 9776	FAB METHODS FOR LOW COST HYBRID SILICON PHOTODETECTOR MODULE RCA CANADA IS DEVELOPING METHODS FOR MOUNTING A PHOTODIODE AND A DETECTOR-PREAMPLIFIER IN A TO/8 CAN. A FIBER OPTIC CONNECTOR WAS MADE BY AMPHENOL AND ATTACHED TO THE LID. SAMPLES OF TWO MODULES WERE BEING TESTED. A .5 INCH DIA. HYBRID FILLS THE CASE	446.5	411.4	35.0	AUG 74	JUN 79
2 76 9778	PH FOR LONG LIFE LIGHT EMITTERS FOR FIBER OPTICS SEE INDIVIDUAL SUBTASKS FOR STATUS.	437.8	392.7	45.0	AUG 74	MAY 81
2 76 9778A	LONG LIFE LIGHT EMITTER FOR FIBER OPTICS LASER DIODE LABS FABRICATED LIFE TEST EQUIPMENT AND VERIFIED ITS PROPER OPERATION. IN A REQUEST BY CORADCOM. THE CONTRACTOR FABRICATED 1 AND 2 JUNCTION LASER DEVICES IN ADDITION TO THE 3 JUNCTION DEVICES REQUIRED BY THE CONTRACT.	437.8	193.8	45.0		MAY 81
2 76 9778B	LONG LIFE LIGHT EMITTER FOR FIBER OPTICS LASER DIODE LABS FABRICATED HURRIS TYPE LEDS WITH THE SMALLER PIGTAIL. THEY MEET THE MODIFIED PERFORMANCE SPECS. LIQUID PHASE EPITAXY, SHALLOW ZINC DIFFUSION, ELECTROLESS PLATING, SOLDERING IN AN INFRARED FURNACE WERE THE PROCESSES USED.	437.8	198.9	45.0		SEP 80

MANUFACTURING METHODS AND TECHNOLOGY PROGRAM
SUMMARY PROJECT STATUS REPORT
2ND SEMIANNUAL SUBMISSION CY 78 RCS DRCHT-301

PROJ NO.	TITLE + STATUS	AUTHORIZED (\$000)	CONTRACT VALUES (\$000)	EXPANDED LABOR AND MATERIAL (\$000)	ORIGINAL PROJECTED COMPLETE DATE	PRESENT PROJECTED COMPLETE DATE
2 76 9781	THIN FILM TRANSISTOR ADDRESSED DISPLAY SEE SUBTASKS BELOW.	590.0	549.0	25.0	AUG 78	FEB 79
2 76 9781A	THIN FILM TRANSISTOR-ADDRESS DISPLAY WESTINGHOUSE IMPROVED SUBSTRATE AND MASK CLEANING PROCEDURES AND GOT BETTER YIELD. * IS LOSING INTEREST AND WILL REDUCE INTERNAL SUPPORT BECAUSE OF LACK OF COMMERCIAL POTENTIAL. THE CONTRACTOR SEEKS TO DROP THE PRODUCTION RATE DEMONSTRATION.					FEB 79
2 76 9781B	THIN FILM TRANSISTOR-ADDRESS DISPLAY AN ADD ON CONTRACT AT WEST. REQUIRED THEM TO PUT HIGH CONTRAST PHOSPHORS AND INTEGRATED SCANNING CIRCUITRY ON THE DIGITAL DISPLAY PANEL. SILK SCREENING IS USED TO APPLY THE PHOSPHORS AND VACUUM METALLIZATION + ETCHING TO APPLY THE FILM CIRCUITRY.					FEB 79
F 79 9784	RUGGEDIZED TACTICAL FIBER OPTIC CABLE ASSEMBLIES DRAFT PURCHASING SPEC OUT FOR COMMENT. SLIPPAGE HAS OCCURRED BECAUSE OF DEPENDANCE ON F789898.	600.0		24.0	APR 82	APR 82
2 77 9835	INT CONTRL CRCT FOR THIN FILM TRANSISTR DISPLAY AERONET ELECTRO SYSTEMS DEVELOPED IN-PROCESS MONITORING AND ADJUSTMENT OF THIN FILM TRANSISTOR MATERIALS AND THICKNESS DURING DEPOSITION. BUT DRIVE CIRCUITRY CAN CONTROL ONLY FIGHT ELEMENTS OF A FLAT PANEL DISPLAY WHILE CIRCUITRY FOR 1000 IS NEEDED.	448.8	398.8	31.3	MAR 79	MAY 80
F 79 9891	ARCTIC (-55 C) ELECTRICAL CABLE JACKET PROCUREMENT PACKAGE BEING PREPARED WITH ECD OF 1 FEB 79.	400.0			OCT 81	OCT 81
2 78 9898	RUGGEDIZED TACTICAL FIBER OPTIC CABLES THE CONTRACT IS NOT YET AWARDED. A 2 STEP PROPOSAL IS UNDER WAY. THREE PROPOSALS WERE RECEIVED. BIDDERS WERE QUESTIONED ABOUT THEIR PROPOSALS. ONE BIDDER WITHDREW AND REPLIES FROM THE OTHER TWO ARE EXPECTED VERY SOON.	600.0		24.0	NOV 79	APR 81
F 79 9938	THREE COLOR LIGHT EMITTING DIODE DISPLAY UNIT R&D HAS UNDERGONE CHANGES AND DESIGN COMPLETION 1 MAR 79. TECHNICAL REQUIREMENTS OF THIS PROJECT MUST AWAIT DESIGN COMPLETION.	510.0			SEP 81	SEP 81

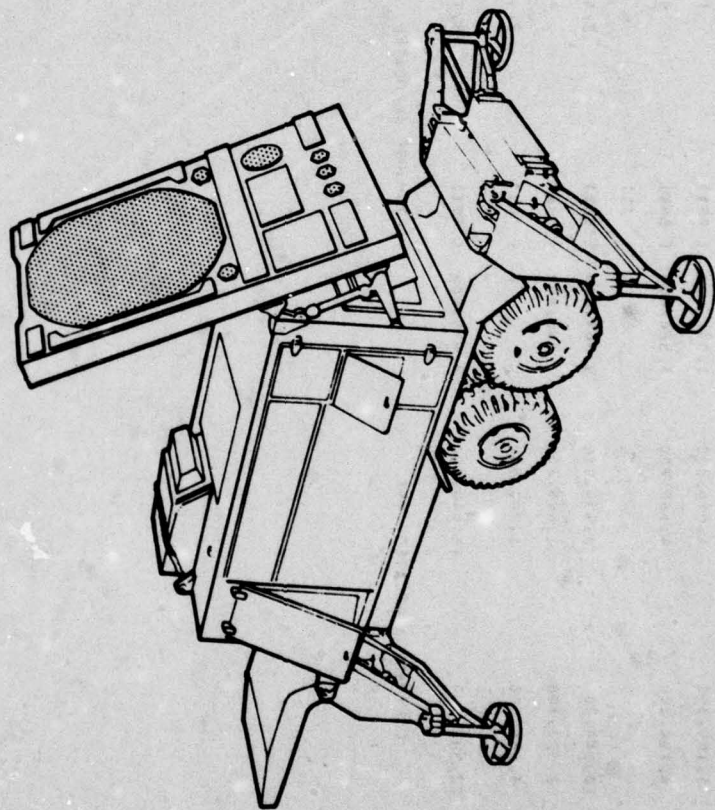

**ELECTRONICS R&D COMMAND
(ERADCOM)**

ELECTRONICS R + D COMMAND
 CURRENT FUNDING STATUS, 2ND CY78

FISCAL YEAR	NO. OF PROJECTS	AUTHORIZED FUNDS (\$)	CONTRACT ALLOCATED (\$)	CONTRACT EXPENDED (\$)	INHOUSE ALLOCATED (\$)	INHOUSE EXPENDED (\$)
75	3	1,189,500	1,076,200	1,031,400 (95%)	113,300	93,900 (82%)
76	12	4,754,000	4,189,700	3,528,000 (84%)	564,300	414,700 (73%)
77	0	0	0	0 (0%)	0	0 (0%)
77	16	10,640,800	9,554,000	8,869,600 (93%)	2,086,800	745,900 (36%)
78	6	2,321,700	1,848,200	266,400 (14%)	473,500	38,900 (8%)
79	6	3,686,000	1,200,500	0 (0%)	2,485,500	49,500 (1%)
TOTAL	43	22,592,000	16,868,600	9,695,400 (57%)	5,723,400	1,362,900 (23%)

AUTHORIZED FUNDING CONTRACT ALLOCATED 75% INHOUSE ALLOCATED 25%

S U B M I T T E D M A N U S C R I P T
 MANUFACTURING METHODS AND TECHNOLOGY PROGRAM
 ST A T U S R E P O R T
 2ND 9F-YEARLY SUBMISSION CY 78 RCS DRMT-301

PROJ NO.	TITLE + STATUS	AUTHORIZED (\$000)	CONTRACT VALUES (\$000)	EXPANDED LABOR AND MATERIAL (\$000)	ORIGINAL PROJECTED COMPLETE DATE	PRESENT PROJECTED COMPLETE DATE
H 76 3126	WHITE STARTER FOR THERMAL BATTERIES EPI HAS COMPLETED FABRICATION, SET-UP, REDESIGN AND PROVE-IN OF THE TOOLING. DIES, SPECIALIZED EQUIPMENT AND CONTROL AND SAFETY SYSTEMS. EPI IS PREPARING FINAL REPORT AND DRAWING PACKAGE FOR THE SPECIALIZED EQUIPMENT. NEW CONTRACT EXPIRATION 30 JAN 7	150.0	90.0	55.0	OCT 77	JAN 79
H 76 3511	FAB OF SURMICON PHOTOMASKS FOR INTEGRATED CIRCUIT DEVICES HELIX-PACKARD AND MCL WORKED ON ON-LINE ERROR CORRECTION SYSTEM. SOFTWARE WAS REVISED TO PERMIT EASIER ERROR DETECTION AND CORRECTION AND CIRCUIT MODIFICATION. PHASE 2 SPECS FOR CAMERA IMPROVEMENT WERE WRITTEN. WILL PERMIT SUBMICRON DIMENSIONS.	66.0	58.1	7.9	SEP 81	SEP 81
2 75 9525	MOT PRESSING OF PTE-ZO CERAMIC ELEMENTS FOR HV TRANSFORMERS. MONEYELL IS APPLYING HOT PRESSING TECHNIQUES TO THE FABRICATION OF VERY THIN LEAD ZIRCONATE TITANATE ELEMENTS INTO PIEZOELECTRIC CERAMIC TRANSFORMERS. PILOT RUN UNITS WERE SUCCESSFULLY TESTED AND DELIVERED TO NV+ENL IN JULY 1978.	220.4	192.9	36.4	OCT 77	AUG 79
2 76 9631	IC FABRICATION USING ELECTRON BEAM TECHNOLOGY TI IS MAKING 256 BIT RAMS USING ELECTRON BEAM LITHOGRAPHY AND COMPARING COST AND YIELD TO RAMS MADE USING PHOTOLITHOGRAPHY. PROCESSING ERRORS HAVE REDUCED YIELD UNTIL IT IS DIFFICULT TO OBTAIN THE REQUIRED 500 SAMPLE CIRCUITS. THE RUN IS NOT TYPICAL.	782.9	670.0	25.0	AUG 77	JUN 79
2 75 9665	MEASUREMENT OF ELECTROCOMPONENTS UNDER DYNAMIC STRESS LOCKHEED BUILT AND TESTED ALL COMPUTER/TESTER CIRCUITRY. EIGHTY PERCENT OF AMPLIFIER TEST SOFTWARE HAS BEEN WRITTEN. ADDITIONAL 260K FUNDING REQUESTED BY LOCKHEED WAS DISAPPROVED SINCE BASIC PROJECT WORK HAS BEEN COMPLETED.	735.1	697.6	37.5	SEP 77	JAN 79
2 76 9736	EPITAXIAL + METALLIZATION PROCESSES F/GAAS IMPATT DIODES MICROWAVE ASSOCIATES APPLIED A MICRO PROCESSOR TO THE CONTROLS OF THE EPITAXIAL REACTOR TO OBTAIN FEEDBACK CONTROL OF THE GROWTH PROCESS. BUT THE QUALITY OF NEW SAMPLES WERE DOWN FROM EARLIER SAMPLES. CRYSTAL GROWTH AND METALLIZATION HAD TO BE MODIFIED	248.8	248.8		JUN 77	JUN 79
H 76 9736	PULSED GA AS IMPATT DIODES MICROWAVE ASSOCIATES BUILT A COMPUTER CONTROLLED REACTOR FOR GROWING R-TYPE EPITAXIAL LAYERS ONTO N-TYPE EPITAXIAL LAYERS IN THE SAME REACTOR. THIS REDUCES CONTAMINATION AND PROVIDES BETTER CONTROL. DIODES WERE BUILT AND CHARACTERIZED ON NEW TEST FOU	500.0	441.2	5.0	JUN 80	JUN 80
2 75 9739	PHOTOLITHOGRAPHIC TECHNIQUES FOR SURFACE WAVE ACOUSTICS HUGHES IS USING PHOTOLITHOGRAPHIC METHODS WITH VERY THIN FLEXIBLE GLASS MASKS TO PRODUCE SURFACE ACOUSTIC WAVE DEVICES. PILOT LIMP RUN WITH A DIFFERENT TYPE SAW FILTERS IS COMPLETED. UNITS HAVE UNDERGONE ELECTRICAL, LIFE AND ENVIRONMENTAL TESTING.	225.0	185.7	20.0	AUG 77	FEB 79

MANUFACTURING METHODS AND TECHNOLOGY PROGRAM
 SUMMARY REPORT
 2ND SEMI-ANNUAL SUBMISSION CY 76 RGS DRCHT-301

PROJ NO.	TITLE + STATUS	AUTHORIZED (\$000)	CONTRACT VALUES (\$000)	EXPENDED LABOR AND MATERIAL (\$000)	ORIGINAL PROJECTED COMPLETE DATE	PRESENT PROJECTED COMPLETE DATE
2 76 9746	THIN FILM AL OXIDE ION BARRIER FOR 18MM MICROCHANNEL PLATES. ITT ELECTRO OPTICAL DIVISION USED ITS VARIAN EVAPORATOR TO APPLY FILM TO MICROCHANNEL PLATES. 2 OF 9 TUBES PASSED THE LIFE TEST. ITT PROCESSES INCLUDE LAYING ON A LACQUER, METALIZING ON A LAYER OF ALUMINUM OXIDE, BURNING OFF THE LACQUER TO MAKE A BARRIER.	480.0	432.0	44.0	JUL 79	JAN 80
2 76 9749	THICK FILM PROCESSING OF MICROWAVE INTEGRATED CIRCUITS. ROCKWELL INTERNATIONAL STOPPED DELIVERY OF ENGINEERING SAMPLES AND CEASED WORK ON THIS PROJECT SINCE FEB 78. ENGINEERING SAMPLES PREVIOUSLY SUBMITTED DID NOT MEET SPEC REQUIREMENTS. WORK SHOULD BE TERMINATED.	360.0	300.0	30.0	JUN 78	JUL 79
2 77 9751	MFR METHODS FOR FABRICATION OF VAG LASER RODS LITTON'S GRINDING AND POLISHING TECHNIQUE YIELDS LASER RODS EXCEEDING SPECS. RODS ARE ACCEPTABLE FOR THE GYS-5 LASER RANGE FINDER, USING A CORE GRINDER. 85% OF THE VAG IS TRANSFORMED INTO RODS BUT A VAG IS STILL IN SHORT SUPPLY.	142.0	64.5	24.0	JAN 79	JUN 79
2 76 9754	CONTIN CYCLE PROC OF SHOCK RESISTANT QUARTZ CRYSTAL UNITS THE IN-LINE ULTRAHIGH VACUUM FABRICATION FACILITY HAS BEEN DESIGNED AND CONSTRUCTED. ASSEMBLY IS COMPLETED AND OPERATIONAL TESTS HAVE BEEN PERFORMED SATISFACTORILY.	426.7	784.7	39.0	AUG 78	DEC 79
2 77 9754	CONTIN CYCLE PROC OF SHOCK RESISTANT QUARTZ CRYSTAL UNITS THE ULTRAHIGH VACUUM QUARTZ CRYSTAL FABRICATION FACILITY IS OPERATING AND IS BEING DERUGGED. CRYSTAL RESONATORS HAVE BEEN SUCCESSFULLY FABRICATED. WORK ON ORDERING EQUIP FOR THE PILOT LINE IS PROGRESSING SATISFACTORILY.	1,489.4	1,426.4	34.0	DEC 79	AUG 80
2 76 9766	DEPOSITION OF A HIGHVOLTAGE INSULATING LAYER FOR THICK FILM ERIE TECH EXPERIENCED EXCESSIVE EPOXY BUILDUP AND ASSEMBLY PROBLEMS IN CONFIRMATORY SAMPLE OF 20 HYBRID THICK FILM HIGH VOLTAGE MULTIPLIER MODULES. SILK SCREENS AND A SPECIAL FIXTURE UTILIZING VACUUM ARE NOW UNDER PROCUREMENT TO RECTIFY THE PROBLEM	162.9	124.5	35.0	AUG 78	SEP 79
2 76 9767	WHAT MEAS FOR DEPOSITION OF THICK FILM CIRCUITS F/CRYST OSC RAYTHEON DID NOT MEET PRODUCTION RATE OR UNIT COST OBJECTIVES. NEED FIXTURES FOR A NEW DESIGN TO INCREASE MANUFACTURING YIELD AND PRODUCTION RATES AND TO DECREASE UNIT COSTS. THE CONTRACT SHOULD BE TERMINATED.	392.7	360.7	30.2	AUG 78	AUG 79
2 76 9771	L TM TEMP PROCESS OF BULK SEMICONDUCTOR SWITCHES + LIMITERS MICROWAVE ASSOCIATES HAS ESTABLISHED PROCEDURES FOR MAKING SEMICONDUCTOR LIMITERS WITH STABLE CHARACTERISTICS OVER 10000 HOURS. MA AND ETDL HAD PROBLEMS COORDINATING TEST MEASUREMENTS. THIS DELAYED ACCEPTANCE OF CONFIRMATORY SAMPLES. FOR TPO-36 + 337	360.0	347.5	32.0	AUG 78	MAR 79

S U M M A R Y P R O J E C T S T A T U S R E P O R T
 MANUFACTURING METHODS AND TECHNOLOGY PROGRAM
 2ND SEMIANNUAL SUBMISSION CY 78 RCS DRGNT-301

PROJ NO.	TITLE + STATUS	AUTHORIZED (8000)	CONTRACT VALUES (8000)	EXPENDED LABOR AND MATERIAL (8000)	ORIGINAL PROJECTED COMPLETE DATE	PRESENT PROJECTED COMPLETE DATE
2 76 9774	IMP PLATED-THRU MLS BY ALTERING DRILL GEOMETRY + FINISH VARIOUS TECHNIQUES OF DETECTING DRILL WEAR WERE EVALUATED. AN INFRARED TEMP SENSING DEVICE WAS THE MOST EFFECTIVE FOUND. THE QUALITY OF DRILLING WAS FOUND TO HAVE LITTLE DEPENDENCY UPON DRILL POINT GEOMETRIES.	125.0	73.8	51.2	JUN 77	JUN 79
2 76 9783	PRODUCTION OF HIGH RESISTIVITY SILICON MATERIAL SEE SUBTASKS BELOW.	501.0	457.1	40.0	AUG 78	FEB 79
2 76 9783A	PRODUCTION OF HIGH RESISTIVITY SILICON MATERIAL HUGHES DEMONSTRATED CRYSTAL GROWTH AND ZONE REFINING EQUIPMENT AND WAFER SLICING AND ETCHING CAPABILITY TO INDUSTRY IN LATE JUNE 78 28000 OHM WAFERS WERE SUPPLIED TO RCA TO MAKE DETECTORS FOR COPPERHEAD AND TO HUGHES FOR MAVERICK. WORK IS COMPLETE.	501.0	457.1	40.0		SEP 79
2 76 9783B	PRODUCTION OF HIGH RESISTIVITY SILICON MATERIAL UNIV. OF DAYTON RESEARCH INST. IMPROVED MEASURING TECHNIQUES FOR CHARACTERIZING HIGH RESISTIVITY SILICON. RESISTIVITY APPROACHES 30,000 OHM-CM. THIS WORK IS PAID FOR BY THE AIR FORCE, AFML ALSO PROVIDED \$457K FOR WORK AT HUGHES.					FEB 79
2 76 9788	FAB OF LOW VOLTAGE START SEALED BEAM ARC LAMPS. VARIAN ASSOCIATES SUBMITTED THE THIRD ENGR SAMPLE. IT WAS NOT EVALUATED BECAUSE THERE IS NO LONGER A REQUIREMENT FOR THE LAMP. NVL ENGINEER FEELS THERE IS NO NEED TO CONTINUE THE WORK TO OBTAIN A TECH DATA PACKAGE BECAUSE THERE IS NO REQUIREMENT.	324.0	290.6	33.3	AUG 78	JUL 79
2 77 9792	PON OF FUNNELLED MCPS WITH HIGH SECONDARY EMITTING COATING GALILEO CORP IS ESTABLISHING METHODS OF FIBER DRAWING, FUNNELING, COATING, EVAPORATING, AND TESTING OF FINER CHANNLED MICROCHANNEL PLATES. PROCESS SPECS HAVE BEEN WRITTEN. MCPS WITH FINE 10 MICRON SPACING ARE HARD TO MAKE AND YIELD IS LOW.	600.0	471.7	22.0	MAR 80	FEB 80
M 78 9793	PON OF INTAGLIATED FINER OPTIC PHOSPHOR SCREEN ITT ELECTRONICS EVALUATED INITIAL UNITS AND DISCOVERED POOR PHOSPHOR MATERIAL PENETRATION INTO THE ETCH PITS. MODIFICATION OF THE PHOSPHOR DISPOSITION PROCEDURE WILL BE MADE. PROCEDURES FOR ETCHING FINER OPTIC GLASS WERE ESTABLISHED AND VERIFIED.	200.0	177.1	8.0	OFC 79	APR 80
2 77 9805	AUTO MICROCIRCUIT BRIDGE PON MEASURE OF QUARTZ CRYSTALS HUGHES IS DEVELOPING A SYSTEM FOR PRODUCTION TESTING BOTH HIGH PRECISION AND GENERAL PURPOSE QUARTZ CRYSTALS. IT WILL INCLUDE AN AUTOMATIC IC BRIDGE FOR PARAMETER MEASUREMENT. THE TECHNIQUE WILL BE INCORPORATED INTO "IL-C-3008 SPEC.	680.0	580.0	75.0	JAN 79	APR 80

S U M M A R Y P R O J E C T S T A T U S R E P O R T
 2ND SEMIANNUAL SUBMISSION CY 78 RCS DRCHT-301

MANUFACTURING METHODS AND TECHNOLOGY PROGRAM

PROJ NO.	TITLE + STATUS	AUTHORIZED (\$000)	CONTRACT VALUES (\$000)	EXPENDED LABOR AND MATERIAL (\$000)	ORIGINAL PROJECTED COMPLETE DATE	PRESENT PROJECTED COMPLETE DATE
M 79 9805	QUARTZ CRYSTAL PARAMETER TESTING CONTRACT NOT YET AWARDED. PROJECT IS A CONTINUATION OF M 77 9805. THE FIRM WILL BUILD MULTICRYSTAL TEMPERATURE CHAMBERS FOR AUTOMATIC ACQUISITION OF FREQUENC TEMP AND AGING DATA. WILL RAISE TEST CAPACITY FROM 25 TO 200 CRYSTALS PER DAY.	400.0			JUN 80	JUN 80
M 79 9807	MMT FOR PROCESSING HIGH STABILITY QUARTZ CRYSTAL UNIT A CONTRACT HAS NOT YET AWARDED. A FIRM WILL BUILD A SECOND PILOT LINE FOR PRODUCING HIGH STABILITY QUARTZ CRYSTALS IN A MULTI-STATION VACUUM CHAMBER. FUNDS WERE TRANSFERRED TO DEPT OF ENERGY. PROJECT IS RELATED TO 2 76 9754 AND 7 79 7541.	760.0	700.0		SEP 80	SEP 80
2 77 9808	AUTO IMPROCESS EVAL OF THICK FILM PRINT + HYBRID CKT ASSY RCA DEVELOPED TECHNIQUES FOR AUTOMATIC IN-PROCESS INSPECTION OF PRINTED HYBRID SUBSTRATES AND SEMI-AUTOMATIC PRECAP INSPECTION OF COMPLETED HYBRID UNITS. CONTROL SIGNAL COND CIRCUITRY AND SOFTWARE ALGORITHMS WERE COMPLETED AND VALIDATED.	515.0	470.0	37.0	AUG 78	APR 79
2 77 9809	MEAS TECHNIQ FOR CHEMICALS IN MPG PROC FOR SOLID ST MICROVW SPECTROGRAPHIC ANALYSTS COMPUTER INTERFACE AND DATA COLLECTION EGMT INSTALLED. CONTRACTOR HAS REQUESTED ADDITIONAL FUNDS OF \$110K TO COMPLETE THE PROGRAM.	553.8	553.8		NOV 78	MAY 79
2 77 9811	REDUC MFG COSTS FOR MICROWAVE POWER TRANSISTORS-IN PROC TUNP TRM HAS PROBLEMS WITH SILICON WAFER QUALITY, PROCESSING PROCEDURES AND PERSONNEL CHANGES. 2 GHZ TRANSISTORS DO NOT MEET SPECS. RUT 4GMZ UNITS DO. TRM FOUND PROBLEMS IN FIVE AREAS	597.4	529.4	35.8	JUL 79	MAR 80
2 77 9812	MMAT FOR SPLIT CYCL STIRLING COOLER. MARTIN MADE 6 COOLERS. THEY WERE TESTED AND MET ALL PERFORMANCE REQUIREMENTS. LIFE TESTING WAS STARTED ON TWO UNITS. TWO COOLERS WERE SHIPPED TO NVL AND ACCEPTED. TWO UNITS ARE IN OPERATION AND PERFORMING WELL IN MANPORTABLE NV SYSTEMS.	795.0	439.9	65.0	JAN 80	JAN 80
2 77 9813	RUGGEDIZED LOW COST QUADRANT DETECTOR FOR CLCP. TEXAS INSTRUMENTS IMPROVED PRODUCTION METHODS FOR PACKAGING AND BONDING LOW COST RUGGEDIZED SILICON QUADRANT PHOTODETECTORS. EPOXY MOUNTED SAMPLES PASSED THE GUN TEST.	375.0	159.0	40.0	JAN 80	JAN 80
2 77 9827	PROCESSING XP ARMOR FOR RADAR HARDENING APPLICATIONS ANALYSES OF MOLDING PROBS FOLLO BY EXPTL WORK AND TESTING ARE LEADING TO BETTER UNDERSTG. PROC CHGES AND EQUIP MODS TO FLTH PROBS. CONTR HAS ADVISED THAT COST OVERRUN ANTICIPATED. SEV NAVY LAB VERY INTERESTED IN POLYPROPYLENE ARMOR AND HAVE REQTD SA	500.0	275.2	176.0	JUL 79	APR 79

MANUFACTURING METHODS AND TECHNOLOGY PROGRAM
 SUMMARY PROJECT STATUS REPORT
 2ND SEMI-ANNUAL SUBMISSION CY 78 RCS DRCHT-301

PROJ NO.	TITLE + STATUS	AUTOMATED RIZED (\$000)	CONTRACT VALUES (\$000)	EXPENDED LABOR AND MATERIAL (\$000)	ORIGINAL PROJECT COMPLETE DATE	PROJECT COMPLETE DATE
2 77 9831	PILOT MFG HUGGED L-RAND CRYSTAL CONT'D TELEMETRY TRANSMITTER JOHNS HOPKINS APPLIED PHYSICS LABS HAS EXPERIENCED 40 MONTHS SLIPPAGE DUE TO PRIORITIES OF OTHER APL PROJECTS. FUNDS ARE NEARLY EXPENDED WITHOUT ACHIEVING A MANUFACTURABLE UNIT. CONTRACT SHOULD BE TERMINATED.	79.0	34.0	OCT 74	SEP 79	
2 77 9834	FABRICATION- SERIES TRANSDUCER ACOUSTIC DELAY LINES WESTINGHOUSE HAS DELIVERED ENGINEERING SAMPLES SETS 1 + 2 AND CARRIED OUT ACOUSTIC DIFFRACTION ANALYSIS. PACKAGE WELDING EXPERIMENTS WITH TEMPERATURE MONITORING HAVE BEEN PERFORMED.	270.6	222.6	MAR 79	DEC 79	
M 78 9841	ZINC SELENIDE WINDOWS AND OPTICAL ELEMENTS RAYTHEON HAS PRODUCED TEST RUN SAMPLES WHICH SHOW OPTICAL QUALITY EXCEEDING GOVT SPECIFICATION. MECHANICAL STRENGTH PROPERTIES HAVE INCREASED 10-20 PERCENT. AUTO WIRE FEED ASSY HAS BEEN INSTALLED IN THE FURNACE. ENG SAMPLE RUN NOT YET EVALUATED.	156.0	140.4	DEC 79	MAR 80	
2 77 9842	THIRD GENERATION .9 MICRON PHOTOCATHODE SEE SUBTASKS A AND B.	1,893.0	1,771.1	DEC 79	OCT 79	
2 77 9842A	VARIAN WORK VARIAN LSE DEVELOPED QC STDS. FOR INCOMING MATERIALS. AUTOMATED THE PUSH-PULL EPITAXIAL MULTI-GROWTH SYSTEM, MECHANIZED GLASS SEALING METHODS, AND SET PROCUREMENT SPECS FOR HIGH PURITY GROWTH MATERIALS. HIGH SPENDING RATE MAY CAUSE COST OVERRUN LATER	963.0	963.0	DEC 79	JAN 80	
2 77 9842B	ITT WORK ITT IS RUNNING LATE WITH ITS SAMPLE PRODUCTION. HAS HAD PROBLEMS WITH FACEPLATE PEELING, BUBBLE FORMATION, AND FACEPLATE CRACKING DURING THE BONDING PROCESS. HAD TROUBLE BUYING Ga-As SUBSTRATES.	808.1	808.1	DEC 79	JAN 80	
M 79 9846	CMOS CIRCUITS USING SILICON ON SAPPHIRE -SOS-TECHNOLOGY A FIRM WILL DRAW MULTIPLE RIBBONS OF SAPPHIRE THRU A DIE, RIBBON WILL BE CUT INTO SUBSTRATES AND SILICON GROWN THEREON. A SEMICONDUCTOR HOUSE WILL FORM COMPLEMENTARY METAL OXIDE SEMICONDUCTOR CIRCUITS ON THE SUBSTRATES TO DEMONSTRATE THEIR QUALITY.	700.0				
2 77 9845	NUMERICALLY CONTROLLED OPTICAL FABRICATION HONEYWELL MADE GERMANIUM BLANKS BY HOT FORMING BUT THEY HAVE UNACCEPTABLY HIGH ABSORPTION. BLANKS MADE BY SPHERICAL CUTTING CLOSE TO ASPHERIC SHAPE AND DIAMOND TURNING BY NUMERICALLY CONTROLLED TOOLS HAVE MUCH LOWER ABSORPTION. HOT FORMING IS INFERIO	333.2	304.2	OCT 77	JUL 80	

MANUFACTURING METHODS AND TECHNOLOGY PROGRAM
 S U M M A R Y P R O J E C T S T A T U S R E P O R T
 2ND SEMIANNUAL SUBMISSION CY 78 RCB DRGMT-301

PROJ NO.	TITLE + STATUS	AUTHORIZED	CONTRACT	EXPENDED	ORIGINAL	PRESENT
		AMOUNT	VALUES	LABOR AND	PROJECTED	PROJECTED
		(\$000)	(\$000)	MATERIAL	COMPLETE	COMPLETE
				(\$000)	DATE	DATE
2 77 9857	AUTO SEPARATION, CARRIER MOUNTING + TESTING OF SEMI-COT DICE HONEYWELL SPENT TIME ON A MATERIAL HANDLING SYSTEM BEYOND SCOPE OF CONTRACT. AN OVERRUN RESULTED. THE MMS INCLUDES AN AIR + MECHANICAL SUBSTRATE HANDLER, A FURNACE LOADER, PARTS LOADER, SOLDER REFLOW, + WIRE BONDER. WORK ON TAB, NOT MMS.	1,275.0	770.8	123.0	OCT 79	SEP 80
H 78 9860	PDN TECHQ=GALLIUM ARSENIDE MIWAF FIED EFFECT TRANSISTORS HUGHES AIRCRAFT CO STARTED THE BASELINE EFFORT FOR GA-AS FETS. A PROCESS MANUAL HAS BEGUN, A SUBSTRATE SPEC WRITTEN, WAFERS ORDERED FOR ION IMPLANTATION, A SILOX DEPOSITION SYSTEM EVALUATED. + PACKAGES SURVEYED, ELECTRON BEAM LITHOGRAPHY WILL BE USED	399.3	399.3		NOV 80	OCT 80
H 79 9869	RAPID REMOVAL OF PLASTIC ENCAPSULANTS THIS PROJECT HAS JUST FUNDED, NO STATUS REPORT HAS REQUIRED.	242.0				
2 77 9873	ANTENNA PATTERN MEASUREMENTS USING NEARFIELD TECHNIQUES ALL EQUIP. HAS BEEN RECEIVED AND IS IN THE PROCESS OF BEING ASSEMBLED. THE CONTRACTOR HAS REQUESTED A CONTRACT MOD. COST AND TIME EXTENSION, DUE TO GOVERNMENT MODIFICATIONS AND EQUIP. DELIVERY DELAYS.	542.4	515.4	27.0	OCT 79	APR 79
H 79 9877	MHT FOR LIGHT EMITTING DIODE ARRAY COMMON MODULE SPECTRONICS INC HAS BEEN SELECTED TO ESTABLISH A MULTI-WAFER EPITAXIAL GROWTH TECHNIQUE AND IMPROVE COMPONENT FABRICATION FOR GAASP (GALLIUM ARSENIDE PHOSPHIDE) MATERIAL USED IN LED ARRAY COMMON MODULES. ANTICIPATED AWARD DATA IS 19 MAR 79.	550.0	500.5	49.5	APR 81	APR 81
H 78 9889	THIRD GENERATION 0.9 MICRON WAFER INTENSIFIER TUBE IIT ELECTRON OPTICS FABRICATED 65 PERCENT OF REQUIRED TUBE PROCESSING CHAMBER FIXTURES. ALL TUBE PARTS NEEDED FOR ENGINEERING SAMPLES, FIRST ARTICLE AND PILOT RUN HAVE BEEN ORDERED FOR THE 3RD GENERATION IMAGE INTENSIFIER TUBES.	1,000.0	632.1	10.0	DEC 79	SEP 80
H 79 9963	LOW COST E-BEAM EQUIPMENT A SPEC. FOR A LOWER COST ELECTRON BEAM EXPOSURE SYSTEM WAS PREPARED. WILL USE BASIC VECTOR, VECTOR-MASTER, AND VARIABLE APERTURE METHODS WITH HIGH SPEED BLANKING. WILL WORK WITH MORE INTENSE EMISSION SOURCES AND HIGH SPEED BEAM POSITIONING. ERM SURVE	1,034.0				

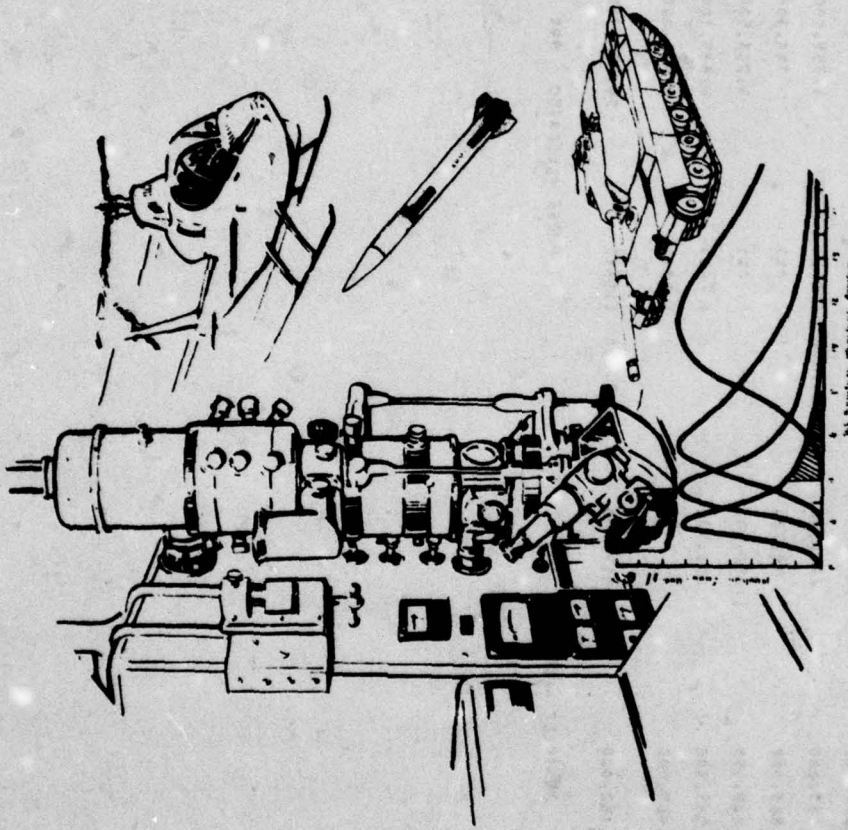

**MATERIALS AND MECHANICS RESEARCH CENTER
(AMMRC)**

**US ARMY MATERIEL DEVELOPMENT AND READINESS COMMAND
(DARCOM)**

(DALCOM)

HEADQUARTERS-DARCOM * ARMY MATERIALS AND MECHANICS RESEARCH CENTER

CURRENT FUNDING STATUS, 2ND CY78

FISCAL YEAR	NO. OF PROJECTS	AUTHORIZED FUNDS (\$)	* CONTRACT FUNDED ALLOCATED (\$)	* CONTRACT FUNDED EXPENDED (\$)	* INHOUSE FUNDED ALLOCATED (\$)	* INHOUSE FUNDED EXPENDED (\$)
74	1	331,000	0	0 (0%)	331,000	329,000 (99%)
75	1	3,500,000	695,200	0 (0%)	2,804,800	2,750,500 (98%)
76	1	4,083,000	228,000	3,625,600 (50%)	3,855,000	3,625,600 (94%)
77	2	883,000	92,700	0 (0%)	790,300	472,300 (59%)
77	2	4,305,000	1,051,500	0 (0%)	3,253,500	2,895,700 (89%)
78	3	5,085,000	251,900	0 (0%)	4,833,100	1,168,300 (24%)
79	2	4,965,000	0	0 (0%)	4,965,000	0 (0%)
TOTAL	12	23,152,000	2,319,300	3,625,600 (15%)	20,832,700	11,281,400 (53%)

AUTHORIZED FUNDING CONTRACT ALLOCATED 10% INHOUSE ALLOCATED 80%

MANUFACTURING METHODS AND TECHNOLOGY PROGRAM
 SUMMARY REPORT
 2ND SEMI-ANNUAL SUBMISSION CY 78 RCS DRCMT-301

PROJ NO.	TITLE + STATUS	AUTHORIZED (\$000)	CONTRACT VALUES (\$000)	EXPENDED LABOR AND MATERIAL (\$000)	ORIGINAL PROJECTED COMPLETE DATE	PRESENT PROJECTED COMPLETE DATE
M 77 6350	MATERIALS TESTING TECHNOLOGY SEE PROJECT M 76 6350 FOR STATUS.	500.0	92.7	407.3	SEP 77	APR 79
M 75 6350	MATERIALS TESTING TECHNOLOGY (MTT) SEE INDIVIDUAL TASK BELOW FOR STATUS.	3,500.0	695.2	2,750.5	DEC 75	JUN 79
M 75 6350A	VIBRATION/SHOCK DIGITAL CONTROL TESTING TECHNIQUES THE FINAL REPORT FOR THIS TASK WAS PUBLISHED AND DISTRIBUTED IN SEPT 1978. THE REPORT DESCRIBES BASIC TRANSIENT WAVEFORM CONTROL PRINCIPLES AND OPERATIONAL FEATURES AND PRESENTS TEST PROCEDURES, AS WELL AS TESTING RESULTS.					JUN 79
M 76 6350	MATERIALS TESTING TECHNOLOGY (MTT) SEE INDIVIDUAL TASKS BELOW FOR STATUS	4,083.0	228.0	3,625.6	DEC 76	APR 79
M 76 6350A	AUTOMATIC INSPECTION DEVICE FOR EXPLOSIVE CHARGE IN SHELL THE ASSEMBLY OF THE ENGINEERING MODEL IS NOW APPROX. TWO-THIRDS COMPLETE, INCLUDING THE SCANNER CONTROL AND DATA ANALYSIS SOFTWARE. THE FAB. IS EXPECTED TO BE COMPLETE FEB 1979. THE DELIVERY TO ARRADCOM FOR ACCEPTANCE TESTING IS SCH. FOR MARCH 1979.					JUN 79
M 76 6350B	CANNON TUBE AUTOMATIC MAGNETIC BORESCOPE INSPECTION THE REQUEST FOR PROPOSAL SCOPE OF WORK HAS BEEN WRITTEN. THE RFP HAS BEEN ISSUED FOR BID. THE CLOSING DATE FOR RECEIPT OF THE PROPOSALS IS 8 DEC 1978.					JUN 79
M 76 6350C	ELASTOMERS FUEL RESISTANCE TEST METHODS ALL IMMERSION TESTING, DATA REDUCTION, AND ANALYSIS HAS BEEN COMPLETED. THE FINAL REPORT IS IN THE PROCESS OF BEING WRITTEN. A PROPOSED INCLUSION FOR ASTM METHOD D-471 HAS BEEN PLACED ON THE LATEST COMMITTEE D-66 BALLOT, CLOSING 16 NOV 6978.					JUN 76
M 76 6350D	HOT FORGED WALL VARIATION MEASUREMENTS THE SYSTEM HAS BEEN BUILT AND DELIVERED. INSTALLATION IS CURRENTLY IN PROGRESS AND IS EXPECTED TO TAKE APPROXIMATELY A MONTH.					JUN 79
M 77 6350	MATERIALS TESTING TECHNOLOGY SEE INDIVIDUAL TASKS BELOW FOR STATUS.	4,000.0	1,051.5	2,695.7	MAY 78	JUN 79
M 77 6350AA	FLEXIBLE POLYMERIC MATERIALS HYDROLYTIC STABILITY TESTING A PROMISING METHOD FOR DETERMINING HYDROLYTIC STABILITY HAS BEEN DEVELOPED. A WIDE VARIATION OF TEST RESULTS HAVE BEEN RECEIVED FROM PARTICIPATING TESTING LABORATORIES. A ASTM D11.37 SUB/COMMITTEE TASK GROUP WILL MEET TO DISCUSS THE TEST RESULTS.					JUN 76

MANUFACTURING METHODS AND TECHNOLOGY PROGRAM
 SUBMARIAN PROJECT STATUS REPORT
 2ND SEMIANNUAL SUBMISSION CY 78 RCS DRCHT-301

PROJ NO.	TITLE + STATUS	AUTHORIZED (\$000)	CONTRACT VALUES (\$000)	EXPENDED LABOR AND MATERIAL (\$000)	ORIGINAL PROJECTED COMPLETE DATE	PRESENT PROJECTED COMPLETE DATE
M 77 6350L	TORSIONAL BRAID APPARATUS TO MONITOR PREPREG AGING THE PROJECT HAS BEEN COMPLETED AND A FINAL REPORT PUBLISHED.				JUN 79	JUN 79
M 77 6350X	ACOUSTIC EMISSION FAILURE MONITORING TECHNIQUES THE FINAL REPORT BY THE CONTRACTOR WAS COMPLETED. A FOLLOW-ON FY79 MTT TASK WILL BE FUNDED TO BUILD A FULL PROTOTYPE SYSTEM FOR ON LINE MOTOR CASE INSPECTION SYSTEM.				JUN 79	JUN 79
M 77 6350Y	PORTABLE NEUTRON RADIOGRAPH SYSTEM THE TASK IS IN THE MIDDLE OF THE DESIGN PHASE. THE RADIOGRAPH HEAD CARRIAGE DESIGN IS NEARING COMPLETION, AS IS THE DESIGN OF THE NUCLEAR SAFETY SYSTEM. A TRI-SERVICE REVIEW OF THE HORLIE N-RAY SYSTEM WAS HELD 5 DEC 6978.				JUN 79	JUN 79
M 77 6350Z	AUTOMATIC BLADE CONTOUR INSPECTION SYSTEM THE PRELIMINARY DESIGN OF THE MECHANICAL STRUCTURE AND THE DATA PROCESSING SYSTEM FOR THE FULL-SCALE PROTOTYPE WAS COMPLETED. TESTS ARE CONTINUING ON THE BREADBOARD TO DETERMINE WHAT ROTOR BLADE SURFACES, PAINTED OR UNPAINTED, CAN BE MEASURED.				JUN 79	JUN 79
M 78 6350	MATERIALS TESTING TECHNOLOGY SEE INDIVIDUAL TASKS BELOW FOR STATUS	4,500.0	251.9	1,166.3	JUN 79	JUN 79
M 78 6350H	MOLOGRAPHIC DEFECT DETECTION BY PRESSURE STRESSING A CONTRACT HAS BEEN AWARDED TO ASSEMBLE A BREADBOARD SYSTEM TO INSPECT M483 PROJECTILES. A DEMONSTRATION IS PLANNED FOR MID JANUARY 1979 TO SHOW THE CAPABILITY OF THE BREADBOARD SYSTEM.				JUN 79	JUN 79
M 78 6350N	RADAR METHOD FOR SENSING AND OUTPUT TESTING OF DETONATORS THE PHASE I CONTRACT HAS BEEN MODIFIED TO INCLUDE TEST FIRING OF DEFECTIVE DETONATORS TO ASSURE THAT THE RADAR SYSTEM CAN DISTINGUISH BETWEEN GOOD AND BAD DETONATORS.				JUN 79	JUN 79
M 78 6350P	ROTARY FORGED TUBE LASER GAGE MEASUREMENT THE REQUEST FOR PROPOSAL SCOPE OF WORK HAS BEEN FINALIZED AND ISSUED FOR RFP. THE SYSTEM WILL BE CAPABLE OF MEASURING ROUNDS, TAPERS, AND STEPS IN CROSS SECTIONS FROM 2 INCHES TO 22 INCHES WITH AN ACCURACY OF ± 0.01 INCHES.				JUN 79	JUN 79
M 78 6350Q	J-INTEGRAL FRACTURE TOUGHNESS AUTOMATED MEASUREMENT MECHANICAL TEST FIXTURES DETAIL MACHINE DRAWINGS HAVE BEEN COMPLETED. SPECIAL COMPONENTS HAVE BEEN ORDERED. TEST SPECIMENS ARE BEING MFG. FROM GUN STEEL SAMPLES. PRELIMINARY TESTS ARE BEING CONDUCTED.				JUN 79	JUN 79

MANUFACTURING METHODS AND TECHNOLOGY PROGRAM
 S U M M A R Y P R O J E C T S T A T U S R E P O R T
 2ND SEMI-ANNUAL SUBMISSION CY 78 RES DRCHT-301

PROJ NO.	TITLE + STATUS	AUTHORIZED VALUES (\$000)	CONTRACT VALUES (\$000)	EXPANDED LABOR AND MATERIAL (\$000)	ORIGINAL PROJECTED COMPLETE DATE	PRESERT PROJECTED COMPLETE DATE
M 78 6350R	<p>COMPUTERIZED COLOR MATCHING SYSTEM</p> <p>THE CONTRACT FOR THIS SYSTEM HAS EXTENDED THREE MONTHS TO ALLOW FOR A FOURTH COLOR MEASURING INSTRUMENT TO BE EVALUATED. THE ANALYSIS FOR THREE OF THE INSTRUMENTS HAS BEEN COMPLETED. THE RESULTS TO DATE APPEAR TO BE EXTREMELY ENCOURAGING.</p>				JUN 79	JUN 79
M 78 6350S	<p>HOLOGRAPHIC INSPECTION OF ROTARY FORGED PREFORMS</p> <p>THE SCOPE OF WORK HAS BEEN FINALIZED AND ISSUED FOR BIDS. THE SYS. WILL CONSIST OF TWO 6-INCH LINEAR TRANSDUCER ARRAYS WITH 4R PIEZOELECTRIC ELEMENTS FOR EACH ARRAY. THE SYS. WILL BE POWERED AND CONTROLLED BY THE HOLOSONICS SYSTEM, HOLOSOCAN 200.</p>				JUN 79	JUN 79
M 78 6350T	<p>OPTICAL DETERMINATION OF DIMENSIONAL GAPS ON TANK PROJECTILE</p> <p>THE REQUEST FOR PROPOSAL SCOPE OF WORK HAS BEEN COMPLETED. THE REP HAS BEEN ISSUED FOR BID. CONTRACT AWARD IS EXPECTED TO BE MADE BY FEB 1979.</p>				JUN 79	JUN 79
M 78 6350U	<p>KNURL INSPECTION ON 155 MM M549 RAP</p> <p>THE REQUEST FOR PROPOSAL SCOPE OF WORK HAS BEEN FINALIZED AND ISSUED FOR BIDS. THE SYS. WILL BE SEMI-AUTOMATIC AS MANUAL LOADING AND UNLOADING WILL BE REQUIRED. THE INSPECTION WILL BE AUTOMATIC INCLUDING THE IDENTIFICATION OF THE REJECTION CAUSE.</p>				JUN 79	JUN 79
M 78 6350V	<p>STABILITY PENETRATION AUTOMATIC INSPECTION SYSTEM</p> <p>A STUDY OF COMMERCIALY AVAILBLE SYSTEMS WAS CONDUCTED. IT WAS DETERMINED THAT THESE SYSTEMS DID NOT HAVE THREE DIMENSIONAL CHECKING CAPABILITIES.</p>				JUN 79	JUN 79
M 78 6350W	<p>ANGULAR VISUAL SECURITY TEST SET</p> <p>THE PRELIMINARY ENGINEERING HAS BEEN COMPLETED. THE ANGULAR SECURITY TESTER IS SCHEDULED TO BE DELIVERED AND SET-UP AT TOBYHANNA 31 MARCH 79. THIS TESTER WILL ENABLE THE DEPOT TO CHECK ON A 100% BASIS THUS ASSURING THE MAXIMUM BATTLEFIELD SECURITY.</p>				JUN 79	JUN 79
M 78 6350X	<p>RAPID NOT FOR DOPANT DENSITY AND DISTRIBUTION</p> <p>DUE TO THE DELAY IN RECEIVING THE LASER MATERIAL SPECIMENS, THE INITIAL TESTS AND EVALUATIONS WERE CONDUCTED USING TARGET DESIGNATOR RODS. THIS TASK IS NOW SCHEDULED TO BE COMPLETE BY APRIL 79.</p>				JUN 79	JUN 79
M 78 6350Y	<p>TRACK BUSHING TEST MACHINE</p> <p>FAB. OF THE TEST MACHINE IS NEARLY COMPLETE. THE CALIBRATION AND PERFORMANCE TESTING ARE EXPECTED TO BE COMPLETED BY 30 DEC 1978. PROGRESS TO DATE IS CONSIDERED EXCELLENT WITH NO MAJOR PROBLEMS EXPECTED.</p>				JUN 79	JUN 79

S U M M A R Y P R O J E C T S T A T U S R E P O R T
 2ND SEMIANNUAL SUBMISSION CY 78 RCS DRGMT-301

PROJ NO.	TITLE + STATUS	AUTHOR- RIZED	CONTRACT VALUES	EXPENDED LAWR AND MATERIAL	ORIGINAL PROJECTED COMPLETE DATE	PRESENT PROJECTED COMPLETE DATE
M 79 6350	MATERIALS TESTING TECHNOLOGY (MTT) THIS PROJECT WAS JUST FUNDED. NO STATUS REPORT WAS REQUIRED.	4,470.0				
M 78 6370	OPTIMIZATION OF MMT PROGRAM EFFECTIVENESS STATEMENT OF WORK HAS BEEN COMPLETED AND SUBMITTED TO THE PROCUREMENT OFFICE FOR ACTION. CONTRACT EXPECTED TO BE LET BY APRIL 1.	35.0		2.0	FEB 80	FEB 80

MANUFACTURING METHODS AND TECHNOLOGY PROGRAM
 SUMMARY REPORT STATUS REPORT
 2ND SEMIANNUAL SUBMISSION CY 76 RCS DRCMT-301

PROJ NO.	TITLE + STATUS	AUTHORIZED (\$000)	CONTRACT VALUES (\$000)	EXPENDED LABOR AND MATERIAL (\$000)	ORIGINAL PROJECTED COMPLETE DATE	PRESENT PROJECTED COMPLETE DATE
4 77 5052	ARMY ENGINEERING DESIGN HANDBOOKS ***** DELINQUENT STATUS REPORT *****	383.0		65.0	JUN 76	DEC 76
4 74 5052	ARMY ENG DESIGN HANDBOOKS FOR PRODUCTN SUPPORT ***** DELINQUENT STATUS REPORT *****	331.0		329.0	JUN 76	DEC 76
4 77 5052	ARMY ENG DESIGN HANDBOOKS FOR PRODUCTN SUPPORT ***** DELINQUENT STATUS REPORT *****	305.0			SEP 79	DEC 76
0 76 5052	ARMY ENG DESIGN HANDBOOKS FOR PRODUCTN SUPPORT ***** DELINQUENT STATUS REPORT *****	550.0			NOV 79	NOV 79
0 79 5052	ARMY ENGINEERING DESIGN HANDBOOK FOR PRODUCTION SUPPORT THIS PROJECT WAS JUST FUNDED, NO STATUS REPORT WAS REQUIRED.	495.0				

FOOD

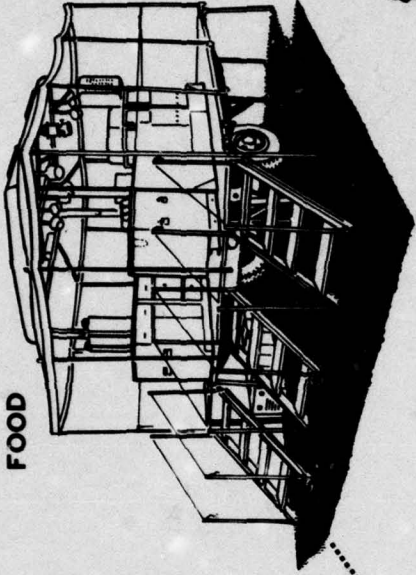

CLOTHING



SHELTER

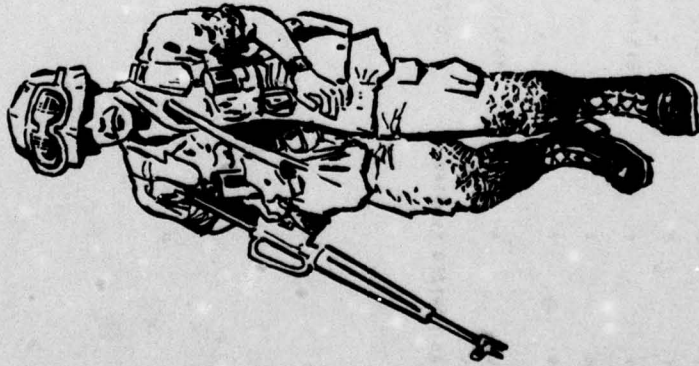

NATICK R&D COMMAND
(NARADCOM)

NATICK RESEARCH AND DEVELOPMENT COMMAND
CURRENT FUNDING STATUS, 2ND CY78

FISCAL YEAR	NO. OF PROJECTS	AUTHORIZED FUNDS (\$)	CONTRACT FUNDS ALLOCATED (\$)	CONTRACT FUNDS EXPENDED (\$)	PERCENTAGE (%)	INHOUSE FUNDS ALLOCATED (\$)	INHOUSE FUNDS EXPENDED (\$)	PERCENTAGE (%)
74	1	110,400	77,200	77,200	(100%)	33,200	33,200	(100%)
75	0	0	0	0	(0%)	0	0	(0%)
76	2	527,700	404,800	404,800	(100%)	122,900	122,900	(100%)
77	0	0	0	0	(0%)	0	0	(0%)
77	1	215,000	160,900	160,900	(75%)	54,100	37,300	(68%)
78	0	0	0	0	(0%)	0	0	(0%)
79	0	0	0	0	(0%)	0	0	(0%)
TOTAL	4	853,100	642,900	642,900	(75%)	210,200	193,400	(92%)

AUTHORIZED FUNDING CONTRACT ALLOCATED 75% INHOUSE ALLOCATED 24%

S U M M A R Y P R O J E C T S T A T U S R E P O R T
 MANUFACTURING METHODS AND TECHNOLOGY PROGRAM
 2ND SEMIANNUAL SUBMISSION CY 78 RCS DRCMT-301

PROJ NO.	TITLE + STATUS	AUTHORIZED	CONTRACT	EXPENDED	ORIGINAL	PRESENT
		VALUES	LABOR AND	PROJECTED	PROJECTED	
		(8000)	MATERIAL	COMPLETE	COMPLETE	DATE
			(8000)	DATE	DATE	
4 74 200N	MFG OF TURNING SHOE LASTS USING NUMERICAL CONTROL. THE CONTRACT HAS BEEN TERMINATED DUE TO LESS THAN SATISFACTORY RESULTS. AFTER REVIEWING WHAT WAS ACCOMPLISHED, A DECISION WILL BE MADE CONCERNING ATTACKING THE PROBLEM AGAIN.	110.4	77.2	33.2	MAR 76	SEP 79
7 76 8035	AUTOMATED PRODUCTION OF INSULATED FOOTWEAR INSTALLATION OF THE SPRAY SYSTEM AND CONVEYOR IS 60 PERCENT COMPLETE. THE INSTALLATION PHASE IS 90 PERCENT COMPLETE. THE BOOT HOLDS HAVE BEEN RECEIVED AND ARE BEING TESTED TO INSURE THEY PRODUCE 800	390.0	320.5	69.5	OCT 78	SEP 79
7 76 8036	NUMERICALLY CONTROLLED HELMET DIE SINKING PROBLEMS WITH ARRADCOM ARE CAUSING DELAYS. ARRADCOM HAS PROMISED DELIVERY OF SOFTWARE AND TOOLING BY APRIL 1979.	137.7	84.3	53.4	SEP 77	JAN 80
0 77 8053	CADAM OF PARACHUTE HARDWARE A LITERATURE SEARCH PROVIDED PERTINENT DIE DESIGN INFORMATION. DIE FILLING, TEMP-TIME CHARACTERISTICS, SLIP LINE VELOCITY DIAGRAMS, AND ISOPRESSURE LINES ARE BEING INVESTIGATED. COMPUTER GRAPHICS WORK HAS RESULTED IN COMPLETION OF 3(ALGORITHMS.	215.0	160.9	37.3	MAR 78	DEC 80

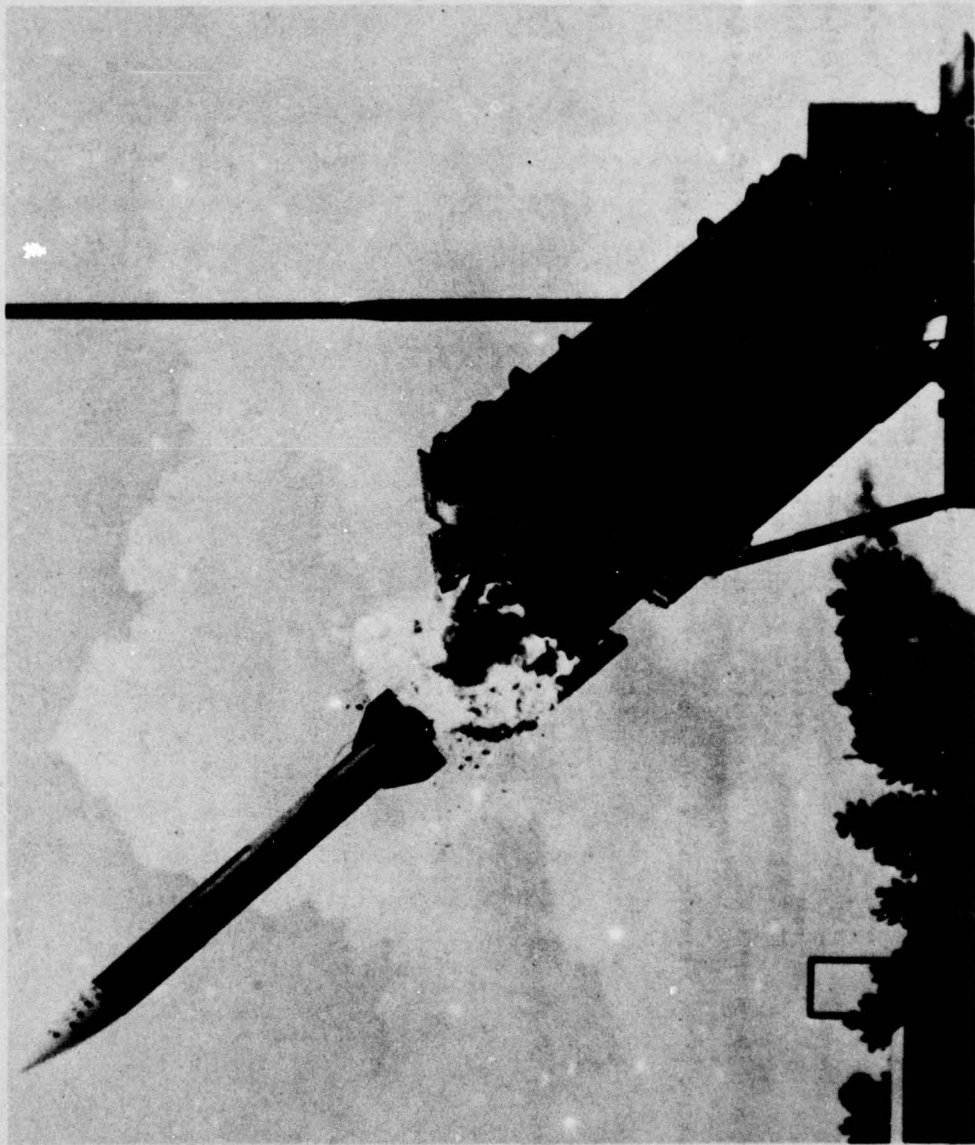

**MISSILE R&D COMMAND
MISSILE MATERIEL READINESS COMMAND
(MIRADCOM, MIRCOM)**

M I S S I L E M A T E R I E L R E A D I N E S S C O M M A N D
C U R R E N T F U N D I N G S T A T U S , 2 N D C Y 7 8

FISCAL YEAR	NO. OF PROJECTS	AUTHORIZED FUNDS (\$)	* CONTRACT FUNDED ALLOCATED (\$)	* CONTRACT FUNDED EXPENDED (\$)	* INHOUSE FUNDED ALLOCATED (\$)	* INHOUSE FUNDED EXPENDED (\$)
76	3	870,200	625,000	610,200 (97%)	240,300	244,000 (99%)
77	1	275,000	243,100	200,300 (82%)	31,900	0 (0%)
77	11	5,559,000	4,680,500	2,276,000 (48%)	878,500	727,000 (82%)
78	31	10,133,700	5,599,100	1,190,400 (21%)	4,534,600	1,427,400 (31%)
79	21	7,580,000	699,500	0 (0%)	6,600,500	13,000 (0%)
TOTAL	67	24,417,000	11,648,100	4,276,900 (36%)	12,569,600	2,414,300 (19%)

AUTHORIZED FUNDING CONTRACT ALLOCATED 49% INHOUSE ALLOCATED 51%

MANUFACTURING METHODS AND TECHNOLOGY PROGRAM
 S U M M A R Y R E P O R T S T A T U S R E P O R T
 2ND SEMIANNUAL SUBMISSION CY 78 RCS DRCHT-301

PROJ NO.	TITLE + STATUS	AUTHORIZED (\$000)	CONTRACT VALUES (\$000)	EXPENDED LABOR AND MATERIAL (\$000)	ORIGINAL PROJECTED COMPLETE DATE	PRESENT PROJECTED COMPLETE DATE
3 76 3073	MANUFACTURING TECHNIQUES FOR STATIC SWITCHES (CAM) FAC STARTED TO ASSEMBLE STATIC SWITCHES (INTERVALMETERS) AFTER RECEIVING NEW ENVIRONMENTALLY TESTED HYBRID MICROCIRCUITS. SWITCHES WERE ENCAPSULATED AND FUNCTIONALLY TESTED SUCCESSFULLY WITH LIVE SQUIBS. NO-COST EXTENSION GRANTED FOR FINAL REPORT.	125.0	69.7	59.2	JUL 76	FEB 79
R 78 3075	INFRARED TESTING OF PC BOARDS AND MICROCIRCUITS PROGRAM PLAN HAS BEEN APPROVED. SURVEY AND ANALYSIS TASKS HAVE BEGUN. PROCUREMENT FOR DIGITAL IMAGE PROCESSOR-CAMERA INTERFACE IS ON ORDER.	335.0	216.8	9.7	AUG 79	OCT 79
R 77 3091	APPLICATION OF CAM TO AFFIXING ELEC CONNECTORS TO CABLES MARTIN DEVELOPED COMPUTER CONTROLLED EQUIPMENT FOR AFFIXING ELEC CONNECTORS TO CABLES. SYSTEM HARDWARE IS COMPLETED AND PROCEDURES WERE VERIFIED. A VIDEO TAPE WAS MADE, AND SYSTEM WAS DEMONSTRATED. EQUIP. IS BEING EVALUATED FOR USE IN-HOUSE AT MARTIN.	140.0	137.1	2.8	AUG 77	FEB 79
R 77 3112	MFG MULTILAYER RIGID-FLEX HARNESS MCDONNELL DOUGLAS IS DEVELOPING METHODS TO INTEGRATE MULTILAYER PRINTED CIRCUIT BOARDS AND FLAT CABLE INTERCONNECTIONS. WILL REDUCE THE USE OF DISCRETE CONNECTORS AND IMPROVE RELIABILITY. MATERIAL SELECTION AND TESTING ARE UNDERWAY.	350.0	164.4	150.9	SEP 78	DEC 79
R 78 3116	IMP PROD METHOD FOR ROSETTE AIR DEF SEEKER OPTICS AND DETECT GENERAL DYNAMICS WILL PRODUCTION ENGINEER THE STINGER SEEKER OPTICS AND DETECTOR. WILL WORK ON UV/IR SANDWICH DETECTOR, OPTICS REPLICATION, IR FILTER, WIRE HARNESS, OPTICAL ALIGNING AND SECURING STRUCTURE.	536.0	470.4	18.0	SEP 79	SEP 79
R 79 3116	IMPROVED PDM METHOD FOR ROSETTE AD SEEKER OPTICS + DETECTOR FOLLOWING THE FY78 EFFORT, GENERAL DYNAMICS WILL DEVELOP SPECIFICATIONS FOR THE NEW PROCESSES, PROVIDE DATA ON TIME, COSTS, SKILLS AND EQUIPMENT, FABRICATE COMPONENTS FOR SEVEN COMPLETE ROSETTE SEEKERS AND VALIDATE PERFORMANCE.	750.0			SEP 79	SEP 79
R 78 3121	APPLICATION AND NOT OF LINE PIPE FOR MOTOR COMPONENTS THE FIRST YEAR OF THE PROGRAM HAS BEEN COMPLETED AND AN INTERIM PROJECT REPORT IS BEING PREPARED. PHASE 7, THE CONCEPT DEMONSTRATION HAS BEEN COMPLETED AND PHASE 8, REPRODUCIBILITY DEMONSTRATION WITH WILL SUPPLIER HAS BEEN INITIATED.	300.0	239.4	106.5	SEP 79	SEP 79
R 78 3126	PROCESSING OF LASER OPTICAL CERAMICS AMRC IS GROWING YITRILIUM ALUMINUM GARNET (YAG) CRYSTALS LIGHTLY DOPED WITH NEODYMIUM (ND). THEY ARE STUDYING THE MATERIAL COMPOSITION TO DETERMINE THE OPTIMUM COMPOSITION FOR GROWTH OF ND-YAG BY THE HEAT EXCHANGER METHOD.	122.0		22.5	AUG 79	AUG 79

S U M M A R Y P R O J E C T S T A T U S R E P O R T
2ND SEMIANNUAL SUBMISSION CY 78 RCS DRGCMT-301

PROJ NO.	TITLE + STATUS	AUTOMATED RIZED VALUES (\$000)	CONTRACT VALUES (\$000)	EXPENDED LABOR AND MATERIAL (\$000)	ORIGINAL PROJECTED COMPLETE DATE	PRESENT PROJECTED COMPLETE DATE
R 77 3133	PROD OF LITHIUM FERRITE PH SHIFTER FOR PHASED ARRAY RADARS RAYTHEON SELECTED THE DIELECTRIC COMPOSITION AND ESTABLISHED OPTIMUM CO-FIRING CONDITIONS FOR COMPOSITE LIFE DIELECTRIC TOROIDAL PHASE SHIFTERS. RELIABLE GRINDING + FINISHING TECHNIQUES FOR TOROIDS ARE BEING INVESTIGATED.	215.0	133.2	44.4	SEP 78	MAR 79
R 78 3133	PROD OF LITHIUM FERRITE PH SHIFTER FOR PHASED ARRAY RADAR MIRACOM MAY USE ITS OPTION TO EXTEND RAYTHEON'S CONTRACT FOR ONE YEAR. THE CONTRACTOR WILL DEVELOP A DIELECTRIC COMPOSITION THAT CAN BE CO-FIRED OR JOINED WITH LITHIUM TITANATE FERRITE TOROID MATERIAL TO FORM A COMPOSITE DIELECTRIC-FERRITE STRUCTURE	315.0		10.0	SEP 79	SEP 79
R 77 3135	PROCESS DEVELOPMENT FOR CARBORANE MANUFACTURE ASSEMBLY OF EQUIPMENT FOR THE PROTOTYPE NMC PRODUCTION LINE IS UNDER WAY. THE PROCESS DEMONSTRATION IS SCHEDULED FOR JULY 79. SAMPLES OF NMC FROM THE 4-INCH REACTOR HAVE BEEN USED TO PREPARE PROPELLANT WHICH WAS EVALUATED AND FOUND TO BE SATISFACTORY	2,000.0	2,000.0		SEP 78	MAR 78
R 78 3136	IMP. MANUFACTURING PROCESSES FOR COMPLIANT BEARING GYROS T40 STEEL RINGS HAVE BEEN ADDED TO THE ROTOR TO FACILITATE DYNAMIC BALANCING. THE BASELINE RG12/715 FORMULATION WAS FOUND TO BE SUPERIOR TO PEROXIDE CURE SYSTEMS. A MULTI-CAVITY MOLD HAS BEEN DESIGNED.	450.0	398.7	19.4	DEC 79	DEC 79
R 79 3136	IMPROVED MFR PROCESSES FOR COMPLIANT BEARING GYROS FY79 EFFORT WILL ESTABLISH A PILOT PRODUCTION LINE, FABRICATE AND ASSEMBLE GYROS.	350.0	289.5		JUL 80	JUL 80
R 78 3140	IMP MANUFACTURING PROCESSES FOR SILICON VIDICONS RCA BUILT A RUN UP 40 CERAMIC ENVELOPE SILICON TARGET VIDICONS FOR TARGET ACQUISITION SYSTEMS. PROCESSES WERE DEVELOPED FOR THE SILICON TARGET, ANTI-REFLECTIVE COATING, TARGET SCREEN AND TARGET SUPPORT STRUCTURE. TUBES PASSED TESTS OK.	140.0	8.0	141.0	MAR 78	DEC 78
R 79 3142	PRODUCTION METHODS FOR LOW COST PAPER MOTOR COMPONENTS PROCUREMENT PACKAGE COMPLETED AND CURRENTLY BEING PROCESSED. MAJOR OBJECTIVE IS TO OPTIMIZE FABRICATION PROCEDURES.	275.0	240.0		JUL 80	JUL 80
R 79 3146	HIGH DENSITY MULTILAYER THICK FILM HYBRID MICRO CIRCUITS CONTRACT HAS NOT YET BEEN AWARDED. PROJECT WILL UTILIZE PHOTOLITHOGRAPHIC TECHNIQUES TO INCREASE THE YIELD OF HIGH DENSITY THICK FILM HYBRID MICROCIRCUITS. OPTIMUM FABRICATION PROCESSES FOR .003 INCH LINES AND .003 INCH SPACES WILL BE ESTABLISHED.	350.0			JUN 80	JUN 80

S U M M A R Y P R O J E C T S T A T U S R E P O R T
2ND SEMI-ANNUAL SUBMISSION CY 78 RCS DRMT-301

PROJ NO.	TITLE + STATUS	AUTHORIZED (\$000)	CONTRACT VALUES (\$000)	EXPENDED LABOR AND MATERIAL (\$000)	ORIGINAL PROJECTED COMPLETE DATE	PRESENT PROJECTED COMPLETE DATE
R 78 3107	ADDITIVE PROCESSES FOR FABRICATION OF PRINT CIRCUIT BOARDS ALL OBJECTIVES OF THE TECHNICAL REQUIREMENTS HAVE BEEN MET. THE SEMI-ADDITIVE PROCESS HAS BEEN SHOWN CAPABLE OF MUCH HIGHER RESOLUTION THAN THE CONVENTIONAL SUBSTRACTIVE PROCESS. AN INDUSTRY-SCALE DEMONSTRATION WAS HELD ON 25-26 OCT 78.	250.0	170.1	50.2	JUN 78	JUN 79
R 78 3150	DEVEL METHOD FOR UTILIZING UV CURED CONFORMAL COATINGS THE CONTRACT WAS PLACED WITH HUGHES ON 15 SEP 78. MATERIALS SELECTION AND TESTING IS PROGRESSING ON SCHEDULE.	126.0	79.4	13.9	SEP 78	NOV 79
R 77 3160	PROD CLEANLINESS CRITERIA AND PROCESSES FOR PRINT WIRING BOARD MARTIN MARIETTA IDENTIFIED MAJOR CONTAMINANTS DEPOSITED ON PRINTED WIRING BOARDS BY FLUXES USED FOR SOLDERING. THEY ARE EVALUATING COMMERCIAL INSTRUMENTS FOR MEASURING CONTAMINATION. WILL DEVELOP MEANS OF MEASURING AND REMOVING PROCESSING CONTAMINANTS.	150.0	67.4	82.6	SEP 78	MAR 80
R 79 3160	CLEANLINESS + PROCESS CRITERIA FOR CIRCUIT BOARDS FOLLOW-ON TO ABOVE WORK ON THIS EFFORT IS CURRENTLY BEING PERFORMED ON PROJECT R773160.	150.0			MAR 80	MAR 80
R 78 3165	PROD PROCESS + TECHNIQUES FOR SEALING HYBRID MIC-CIR PACK DESIGN AND DRAFTING FOR THE VACUUM BAKE OVEN IS COMPLETE. VACUUM BAKE OVEN WAS NOT FABRICATED BECAUSE COST WAS TOO GREAT TO IMPLEMENT UNDER EXISTING FUNDS. CONTRACT WAS AWARDED FOR FABRICATION OF A FINE LEAK TEST CHAMBER SYSTEM.	220.0	147.0	23.0	NOV 79	NOV 79
R 78 3167	PROD CONTROLS TO PREVENT PLATED-THROUGH HOLE CRACKING HUGHES PREPARED AND PURIFIED THREE ACID COPPER BATHS FOR USE IN PRE-SCREENING TESTS OF PLATED THRU HOLES. SAMPLES ARE PLATED DAILY AND TESTED FOR PERCENT ELONGATION, ULTIMATE TENSILE STRENGTH AND MICROHARDNESS. BATH SOLUTIONS ARE ANALYZED DAILY.	223.0	114.1	25.0	MAR 79	MAR 79
R 77 3168	PRODUCTION OF CIRCUIT BOARD HEAT PIPE HUGHES CONTINUED WORK ON LEAK DETECTION, FILL AND THERMAL TEST STATIONS. EVALUATION OF SELL BONDING, WICK FABRICATION AND ATTACHMENT, AND PINCH OFF TECHNIQUES WERE COMPLETED. HEAT PIPE SHELL AND WICK CUTTING AND STAMPING DIES HAVE BEEN ORDERED.	172.0	147.1	24.8	SEP 78	MAR 79
R 77 3169	AUTO OPTICAL INSPECTION OF PC BOARDS AND COMPONENTS (CAM) ONE OF THE CONTRACTORS HAVE COMPLETED THE WORK AND HAVE SUBMITTED THE FINAL REPORT FOR APPROVAL. THE OTHER CONTRACTOR IS NEARING THE COMPLETION OF THE INSPECTION SCANNER.	275.0	268.6	6.4	SEP 78	MAR 79
R 78 3171	AUTO MONITOR AND CONTROL FOR WAVE SOLDERING MACHINES WESTINGHOUSE IS IDENTIFYING PARAMETERS FOR WAVE SOLDERING AND THE PARAMETERS ARE WAVE HEIGHT, BOARD PREHEAT, FLUX ACTIVITY, BOARD ANGLE. AN IR SCANNER WILL LOOK AT COMPONENT LEAD TEMPE	454.0	253.2	25.0	SEP 80	MAR 80

MANUFACTURING METHODS AND TECHNOLOGY PROGRAM
SUMMARY PROJECT STATUS REPORT
2ND SEMI-ANNUAL SUBMISSION CY 78 RCS DRCHT-301

PROJ NO.	TITLE + STATUS	AUTHORIZED (\$000)	CONTRACT VALUES (\$000)	EXPENDED LABOR AND MATERIAL (\$000)	ORIGINAL PROJECTED COMPLETE DATE	PRESENT PROJECTED COMPLETE DATE
R 77 3183	IMPROVED PROCESSES FOR INERTIAL GRADE G-FLEX ACCELEROMETER THE CONTRACT WAS EXTENDED AT NO COST TO THE GOVERNMENT TO ALLOW SUNSTRAND TO INVESTIGATE EFFECTS OF MOISTURE ON THE ACCELEROMETER SCALE FACTOR. AN INTERIM REPORT WILL REPLACE THE FINAL REPORT IAW THE CONTRACT MODIFICATION.	165.0	114.4	25.0	DEC 78	MAR 79
R 78 3183	IMPROVED PROCESSES FOR INERTIAL GRADE G-FLEX ACCELEROMETER SUNSTRAND IS ANALYZING THE MAGNETIC CIRCUIT ASSOCIATED WITH THE ACCELEROMETER. ALSO, THEY ARE LOOKING AT THE EFFECT OF MOISTURE ON THE ACCELEROMETER.	180.0	115.6		JUL 80	NOV 79
R 78 3188	INFRARED IMAGING SEEKERS FOR THERMAL MOVING MISSILES TEXAS INSTRUMENTS IS STUDYING ALTERNATE IR SEEKER COMPONENTS. PLASTIC VS METAL OPTICS HOUSINGS ARE BEING EVALUATED AS ARE ALTERNATE INTERFACE MECHANISMS AND IR DOMES. IR IMAGE SEEKER DESIGN TO UNIT COST GOALS WILL BE SET.	500.0	500.0		MAR 79	MAR 79
R 78 3204	INTERNAL SHEAR FORGING PROCESSES FOR MISSILE PRIME STRUCTURE A CONTRACT WAS NEGOTIATED WITH IITRI AND BECAME EFFECTIVE 21SEP78. THE CONTRACTOR IS REVISING SKETCHES, DRAWINGS, AND PROCURING MATERIALS.	314.0	123.8	190.2	OCT 80	SEP 80
R 77 3217	AUTOMATED PROD. OF TRAVELING WAVE TUBES LITTON IS DESIGNING A FAST WARM-UP CATHODE OF SMALL SIZE, REQUIRING REDUCED POWER, HAVING HIGH EMISSION DENSITY ADEQUATE FOR SHORT TACTICAL MISSIONS. OSMIUM-COATED AND ITRIDIUM MIXED CATHODES ARE BEING CONSIDERED. EXTENSIVE TESTING IS REQUIRED.	498.0	316.8	30.0	FEB 79	JUL 80
R 79 3217	AUTOMATED PRODUCTION METHODS FOR TRAVELING WAVE TUBES FOLLOW-ON TO ABOVE WORK ON THIS EFFORT IS BEING PERFORMED ON PROJECT R773217.	740.0			JUL 80	JUL 80
R 78 3218	REDUCE THE FINISHING COST OF FUSED SILICA RADDOMES THE KILN WAS COMPLETED. AN OVEN WAS DESIGNED AND FABRICATED TO REDUCE DRYING TIME OF THE MOLD. ONE SUCCESSFUL CASTING WAS ACHIEVED IN THREE ATTEMPTS. AIR DRYED RADDOMES HAVE CRACKED.	312.7	12.7	208.4	OCT 79	OCT 79
R 79 3219	AUTOMATIC POLYMER ATTACHMENT PRODUCTION METHODS A PROCUREMENT PACKAGE IS BEING DEVELOPED TO ESTABLISH MANUFACTURING TECHNIQUES FOR AN AUTOMATIC POLYMER ATTACHMENT METHOD.	200.0			AUG 79	AUG 79
3 76 3227	LOW COST PROD METH FOR HAND HYBRID CHIP W/TAPE CAR LEAD FR SEE SUBTASKS BELOW.	550.0	411.0	138.8	NOV 77	OCT 78

S U M M A R Y P R O J E C T S T A T U S R E P O R T
2ND SEMI-ANNUAL SUBMISSION CY 78 RCS ORCMT-301

PROJ NO.	TITLE + STATUS	AUTHORIZED (\$000)	CONTRACT VALUES (\$000)	EXPENDED LABOR AND MATERIAL (\$000)	ORIGINAL PROJECTED COMPLETE DATE	PRESENT PROJECTED COMPLETE DATE
3 76 3227A	HONEYWELL WORK HONEYWELL COMPLETED WORK ON TAPE CARRIER LEAD FRAMES FOR ATTACHING CHIPS TO THICK FILM HYBRID CIRCUITS. QUANTITIES OF SAMPLE CIRCUITS WERE ATTACHED TO LEAD FRAMES FOR USE IN SEVERAL MISSILE CONTROL SYSTEMS. COST AND RELIABILITY DATA ARE SOUGHT.		149.9			SEP 79
3 76 3227B	DETEX SYSTEMS WORK DETEX SYSTEMS IS WORKING WITH UTILIZATION TECHNIQUES.		32.0			SEP 79
3 76 3227C	HONEYWELL MODIFICATION HONEYWELL COMPLETED TESTING AND BONDING CHIPS ONTO TAPE CARRIERS USING THERMO-COMPRESSION BONDING. STARTED ASSEMBLY OF MISSILE CIRCUITS FOR TWO PURPOSES- TO OBTAIN COST AND RELIABILITY DATA AND TO USE THE SAMPLES IN MISSILE CIRCUITRY.		54.0			SEP 79
3 76 3227D	HONEYWELL OPTION HONEYWELL ESTABLISHED PROCESS SPECS FOR TAPE CARRIER, WAFER MOUNTING, DIE SEPARATION, INNER LEAD BONDING, OUTER LEAD BONDING, DIE TESTING, AND REWORK. REPORT CORL A005 WILL BE AVAILABLE ON THIS PHASE.		175.0			SEP 79
R 78 3228	PRODUCTION METHODS FOR EXTRUDABLE HTPB PROPELLANT THE DESIGN CONCEPT WAS CHANGED FROM A ROTARY MACHINE CONSISTING OF 12 STATIONS TO USING MULTIPLES OF A SINGLE STATION, MULTI-HEADED MACHINE. A CONTRACT WAS LET FOR THE HARD DESIGN OF THE PROTOTYPE AND ITS FABRICATION UPON DESIGN APPROVAL.	200.0	150.0		SEP 79	SEP 79
R 78 3229	METHODOLOGY FOR PRODUCING LOW COST/ DISPOSABLE MANDRELS ALL PHASES OF THE CONTRACT HAVE BEEN COMPLETED EXCEPT THE PRODUCTION RUN.	275.0	153.5	22.0	SEP 79	JAN 79
3 76 3231	METHODS FOR THE PRODUCTION OF SQUEEZE CASTINGS SQUEEZE CASTINGS FOR TWO COMPONENTS WERE EVALUATED. PRELIMINARY PROCESS SPECS WERE DRAWN. UPON EVALUATION, THE PREFORMS PROVED TO BE DEFECTIVE. A FINAL REPORT HAS BEEN WRITTEN.	195.2	145.2	50.0	JAN 78	SEP 79
3 77 3232	COMPUTERIZED PRODUCTION PROCESS PLANNING THE EFFORT ON THE COST DRIVERS ANALYSIS IS CONTINUING.	275.0	243.1		JUL 77	JUL 79
R 78 3242	DIGITAL FAULT ISOLATION OF PRINTED CIRCUIT BOARD HUGHES WILL DETERMINE THE EQUIPMENT AND SOFTWARE NEEDED TO PERFORM DIGITAL FAULT ISOLATION ON PRINTED WIRING BOARDS USED IN MISSILE SYSTEMS. HUGHES STARTED A TESTER SURVEY AND BOARD RELIABILITY EVALUATION.	425.0	207.0	20.0	SEP 79	JUN 80

SUMMARY PROJECT STATUS REPORT
 2ND SEMI-ANNUAL SUBMISSION CY 78 RCS DRCHT-301

PROJ NO.	TITLE + STATUS	AUTHORIZED (\$000)	CONTRACT VALUES (\$000)	EXPANDED LABOR AND MATERIAL (\$000)	ORIGINAL PROJECTED COMPLETE DATE	PRESENT PROJECTED COMPLETE DATE
R 79 3242	DIGITAL FAULT ISOLATION OF PRINTED CIRCUIT BOARD FOLLOW ON TO ABOVE. ON AN OPTION TO FY78 CONTRACT HUGHES WILL DETERMINE THE EQUIPMENT NEEDED FOR DIGITAL FAULT ISOLATION ON POPULATED PC BOARDS. WILL BE PROGRAMMED TO ISOLATE FAULTS DOWN TO THE DEFECTIVE COMPONENT ON THE BOARDS. IS SOFTWARE ORIENTED.	425.0			APR 80	APR 80
R 78 3253	HIGH CURRENT DENSITY CATHODES SPERRY UNIVAC INITIATED WAFER PROCESSING AND COMPLETED IT THROUGH UNIDY GROWTH. THEY COMPLETED SPECIFICATION OF 19 PROCESSING STEPS. THEY SPECIFIED AND ORDERED INITIAL ARTWORK FOR OPTICAL LITHOGRAPHY. E-BEAM TECHNOLOGY WILL BE USED TO MAKE THE ARTWORK	175.0	124.7	10.0	JUN 80	JUN 80
R 79 3253	HIGH CURRENT DENSITY CATHODES FOLLOW ON TO ABOVE. SPERRY-UNIVAC WILL CONTINUE WORK ON LOW COST PROCESSES FOR MAKING LONG LIFE THIN FILM FIELD EMISSION CATHODES FOR ELECTRON TUBES. PROCESSES INCLUDE THIN FILM DEPOSITION, CLEANING, AND SEALING.	175.0			JUN 80	JUN 80
R 78 3254	SEMI-FLEXIBLE THIN FILM SEMICONDUCTORS RFPs WERE ISSUED TO PROSPECTIVE BIDDERS. PROPOSALS WILL BE EVALUATED IN FEB 79. A FIRM WILL DEVELOP A LOW COST COMPUTER CONTROLLED MANUFACTURING FACILITY FOR MAKING THIN FILM TRANSISTORS AND INTEGRATED CIRCUITS. THIN FILM TRANSISTORS IMMUNE TO WATER	400.0			JUN 79	SEP 80
R 79 3267	PDN PROC FOR REMOVING EPOXY SMEAR IN PLATED-THROUGH HOLES A PROCUREMENT PACKAGE HAS BEEN PREPARED FOR THE DEVELOPMENT OF EQUIPMENT AND METHODOLOGY TO REMOVE ADHESIVE SMEAR ON INTERNAL CONDUCTORS.	200.0			SEP 79	SEP 79
R 78 3268	AUTOMATIC CONTROL OF PLATING CONTRACT AWARDED TO GENERAL DYNAMICS CORP. SENSOR SYSTEM AND CONTROLLER WERE PROCURED. SURVEY OF ANALYTICAL EQUIP AND PLATING INDUSTRY IS ON GOING. SPECIFICATIONS DEVELOPED FOR COMPUTER WITH EPROM RAM AND FLOPPY DISK TO INTEGRATE CONTROLLER SENSORS	450.0	143.9	54.0	OCT 79	SEP 79
R 79 3268	AUTOMATIC CONTROL OF PLATING (CAM) FUNDING RECEIVED AT THE LEVEL REQUESTED. THE FY79 EFFORT WILL EXPAND AND CONTINUE THE FY78 EFFORT A PILOT PRODUCTION LINE WILL BE DEMONSTRATED WITH REPRESENTATIVE PRINTED WIREBOARDS FROM ARMY SYSTEM. NO WORK YET ACCOMPLISHED WITH FY79 FUNDS.	450.0			SEP 80	SEP 80
R 79 3272	FLEX PRINTED CIRCUITS WITH INTEGRAL MOLDED CONNECTORS THE CONTRACT IS NOT YET AWARDED. MANUFACTURING PROCESSES, METHODOLOGY AND SPECIFICATIONS FOR FLEXIBLE PRINTED CIRCUITS WITH MOLDED CONNECTORS WILL BE ESTABLISHED. FOR STINGER, HELLFIRE, AND TACTICAL GROUND SUPPORT MISSILE.	217.0			OCT 81	OCT 81

MANUFACTURING METHODS AND TECHNOLOGY PROGRAM
 S U M M A R Y P R O J E C T S T A T U S R E P O R T
 2ND SEMIANNUAL SUBMISSION CV 78 RCS ORCMT-301

PROJ NO.	TITLE + STATUS	AUTHORIZED (\$000)	CONTRACT VALUES (\$000)	EXPENDED LABOR AND MATERIAL (\$000)	ORIGINAL PROJECTED COMPLETE DATE	PRESENT PROJECTED COMPLETE DATE
R 79 3280	ENGR ANALYSIS OF MFG PARAMETERS FOR THERMAL BATTERIES WORK ON THIS PROJ WAS HELD UP PENDING TRI-SERVICE REVIEW OF THERMAL BATTERY PROBLEMS. MTG WAS HELD IN JAN 79 AND A NEW REDIRECTED PROGRAM PLAN AGREED UPON. BASICALLY CONSULTANT TRN WILL REVIEW THERMAL BATTERY PROBLEMS IN ALL SERVICES AND REC NEXT STEP	145.0			SEP 80	SEP 80
R 78 3372	MANUFACTURING METH. FOR MAGNETIC COMPONENTS OUT OF 24 MATERIALS EVALUATED, 5 WERE SELECTED. ELECTRICAL AND ENVIRONMENTAL TESTING HAS STARTED. THE DETERMINATION OF EFFECTS OF HANDLING TECHNIQUES ON ULTRA-FINE WIRES HAS STARTED.	410.0	362.0		OCT 79	OCT 79
R 79 3372	DEV + EVAL OF MFR METHODS FOR MAGNETIC MATERIALS EFFORT WILL PROVIDE THE MANUFACTURING TECHNIQUES FOR ELECTROMAGNETIC DEVICES OF SIGNIFICANTLY REDUCED SIZE AND WEIGHT.	610.0			OCT 79	OCT 79
R 78 3376	TESTING ELECTRO-OPTICAL COMPONENTS AND SUBSYSTEMS TECHNICAL REQUIREMENTS REQUIRED A MEMORANDUM BASED ON SEVERAL LEGAL REVIEWS. PROCUREMENT AND SERVICE CONTRACT REVIEW BOARD PACKAGES HAVE BEEN PREPARED AND IS SCHEDULED FOR REVIEW ON 16 JAN 79.	375.0	325.0	10.0	DEC 80	DEC 80
R 79 3381	LDX COST, IMPROVED 2-D HEAT SHIELDS CONTRACT Pkg COMPLETED AND SENT TO THE CONTRACTING OFFICER ON 20 DEC 78. THE CONTRACT WILL BE AWARDED COMPETITIVELY.	500.0			MAR 80	MAR 80
R 78 3396	INJECTION MOLDING OF ONE PIECE NOZZLES A PROCUREMENT PACKAGE HAS BEEN COMPLETED AND IS CURRENTLY BEING PROCESSED.	180.0			MAR 80	MAR 80
F 79 3410	PRODUCTION METHOD FOR HEAT PIPES FOR HYBRID/LSI THE CONTRACTOR TO BE SELECTED WILL ESTABLISH VOLUME PRODUCTION EQUIPMENT. TECHNIQUES AND PROCESSES FOR FABRICATING HEAT PIPES, PROCESSES WILL INCLUDE EXTRUSION, POWDER WICK FORMING AND OTHER LOW COST METHODS TO REPLACE HIGH COST PROCESSES.	250.0		15.0	SEP 79	SEP 79
R 78 3436	DEVELOPMENT OF CERAMIC CIRCUIT BOARDS AND LARGE AREA HYBRIDS TWO CONTRACTS HAVE BEEN LET IN SUPPORT OF THIS EFFORT (GENERAL DYNAMICS AND MARTIN MARIETTA AEROSPACE). THE PROJECTS ARE EACH UNIQUE IN THEIR APPROACH TO THE PROBLEM.	325.0	271.8	10.0	DEC 79	NOV 79
R 79 3436	DELIDDING, PARALLEL SEAM SEALED HYBRID MICROELECT PACKAGES A CONTRACTOR TO BE SELECTED WILL DEVELOP COST EFFECTIVE MANUFACTURING PROCESSES AND TECHNIQUES TO SAFELY DELID HIGH COST PARALLEL SEALED HYBRID MICROELECTRONIC PACKAGES TO PERMIT REPAIR OR REWORK. THE PROCUREMENT PACKAGE IS BEING PREPARED.	200.0			OCT 79	OCT 79

SUMMARY REPORT
2ND SEMIANNUAL SUBMISSION CY 78 RCB DRCHT-301

PROJ NO.	TITLE + STATUS	AUTHORIZED (\$000)	CONTRACT VALUES (\$000)	EXPENDED LABOR AND MATERIAL (\$000)	ORIGINAL PROJECTED COMPLETE DATE	PRESENT PROJECTED COMPLETE DATE
R 78 3440	PRODUCTION TESTING OF CONTROL SYSTEMS FOR GUIDED WEAPONS CONTRACT DAA40-79-C-0020 WAS AWARDED 5 DEC 78. THE CONTRACTOR SUBMITTED A CONTRACT PLAN WITH MILESTONES IN ACCORDANCE WITH CORL SEQUENCE NO. 009.	550.0	490.4	12.0	APR 80	OCT 79
R 78 3441	APPLICATION OF HIGH ENERGY LASER MANUFACTURING PROCESSES EFFORTS ARE STILL CONTINUING TO TRY TO IMPROVE THE RELIABILITY OF THE LASER SYSTEM. WELDING TESTS ARE CONTINUING. THE OPTICS ARE BEING MODIFIED.	490.0	140.0	280.0	SEP 79	JUN 79
R 79 3441	APPLICATION OF HIGH ENERGY LASER MANUFACTURING PROCESSES PLANS FOR THE SECOND YEAR ARE BEING FINALIZED.	400.0			SEP 79	SEP 79
R 79 3444	FULLY ADDITIVE MANUFACTURING FOR PRINTED WIRING BOARDS A PROCUREMENT PACKAGE HAS BEEN PREPARED AND IS SCHEDULED TO BE CONTRACTED DURING DEC 179.	200.0			SEP 79	SEP 79
R 79 3445	PRECISION MACHINING OF OPTICAL COMPONENT THIS PROJECT WILL ESTABLISH AND DOCUMENT MANUFACTURING METHODS/TECHNIQUES TO REDUCE COST AND MANUFACTURING TIME ASSOCIATED WITH OPTICAL COMPONENTS.	300.0	170.0		OCT 81	OCT 81
R 77 3452	LOW COST QUANTITY PRODUCTION TECHNIQUES FOR LASER SEEKERS MARTIN MARIETTA IS IN PHASE 3 OF A PROGRAM TO COMBINE A DEVELOPED LOW COST LASER SEEKER HEAD WITH THE ELECTRONICS OF ANOTHER MISSILE SYSTEM. WORK AREAS WILL INCLUDE OPTICAL ALIGNMENT, ADHESIVE BONDING RAPID PURGING AND SEALING OF PLASTIC GYRO UNIT.	1,000.0	1,125.5		SEP 79	SEP 79
R 78 3453	GROUND LASER LOCATOR DESIGNATOR PRODUCTION IMPROVEMENTS A CONTRACTOR WILL BE SELECTED TO COST EFFECTIVELY PRODUCE AN ENGINEER A GROUND LASER LOCATOR DESIGNATOR. HE WILL ESTABLISH PRODUCTION PROCESSES AND PROCEDURES FOR OPTICAL COMPONENTS AND ELECTRONIC ASSEMBLIES.	211.0			DEC 80	DEC 80
R 78 3454	LOW COST - HI VOLUME RADIOGRAPHIC INSPECTION PRELIMINARY DESIGN REQUIREMENTS HAVE BEEN DEFINED. COMPUTER SYSTEMS HAVE BEEN EXAMINED RESULTING IN THE IDENTIFICATION OF HD-1000 AS THE SYSTEM THAT MEETS THE TECHNICAL AND COST REQ. THE SELECTION OF THE VIDEO COMPUTER INTERFACE IS FORTH COMING.	200.0	147.6	10.6	FEB 80	MAR 80

S U M M A R Y P R O J E C T S T A T U S R E P O R T
 2ND SEMIANNUAL SUBMISSION CY 78 RCB DRCDT-301

PROJ NO.	TITLE + STATUS	AUTHORIZED (\$000)	CONTRACT VALUES (\$000)	EXPENDED LABOR AND MATERIAL (\$000)	ORIGINAL PROJECTED COMPLETE DATE	PRESENT PROJECTED COMPLETE DATE
3 77 3115	ENGINEERING FOR METROLOGY AND CALIBRATION SEE PROJECT 3 78 3115 FOR STATUS	594.0	206.0	361.0	SEP 78	DEC 79
3 78 3115	ENGINEERING FOR METROLOGY AND CALIBRATION SEE INDIVIDUAL SUBTASK BELOW FOR STATUS.	661.0	234.0	135.0	SEP 79	SEP 79
3 78 3115A	JOSEPHSON EFFECT VOLTAGE STANDARD THE 1-PPM VOLTAGE STANDARD HAS BEEN EVALUATED AT NBS. THE DELIVERY OF THE 1-PPM VOLTAGE STANDARD IS SCHEDULED IN EARLY 1979. THE CONSTRUCTION OF THE VOLTAGE STANDARD SYSTEM HAS BEEN COMPLETED.					SEP 79
3 78 3115C	LOW FREQUENCY RMS VOLTMETER THE PREAMPLIFIER WAS ASSEMBLED AND INSTALLED IN THE INSTRUMENT. THE PREAMPLIFIER AS INSTALLED PERFORMED SATISFACTORILY. ALL THE SOFTWARE FOR THE PREAMPLIFIER HAS BEEN WRITTEN, BUT NOT FULLY DEBUGGED.					SEP 79
3 78 3115D	AUTOMATIC AC/DC THERMAL VOLTAGE MEASUREMENT SYSTEM FINAL TRIM ADJUSTMENTS AND INSTALLATION OF THE 1000/1 DIVIDER INTO THE THERMOELEMENT COMPARTOR WAS COMPLETED. ALL HARDWARE WIRING IS NOW DEBUGGED AND FUNCTIONING. INITIAL WORK ON AC/DC TEST SOFTWARE HAS COMMENCED.					SEP 79
3 78 3115E1	PRESSURE TRANSDUCER SYSTEMS HYD. PRESSURE STD. WORK PRESENTLY UNDERWAY IS MORE APPROPRIATE FOR MACI AND IS BEING ACCOMPLISHED AS A SUBTASK UNDER 3 78 2067.					SEP 79
3 78 3115E2	PRESSURE TRANSDUCER SYSTEMS PNEUMATIC PRESSURE STD-TESTS ARE PRESENTLY BEING RUN ON A SYSTEM MFG UTILIZING STD INDUSTRIAL TECHNIQUES. PRELIMINARY RESULTS INDICATE THAT THE ELECTRONICS PORTION OF THIS SYSTEM HAS VERY SMALL TEMPERATURE DEPENDENCY.					SEP 79
3 78 3115F	MICROPROCESSOR TECHNOLOGY A HIGH SPEED TERMINAL WITH SOFTWARE HAS BEEN PARTIALLY INSTALLED. AN OPTIONAL 1200 PC BOARD HAS BEEN DELAYED IN SHIPMENT. THE EVALUATION BOARD IS CURRENTLY BEING USED TO TEST A DIFFERENTIAL AND ABSOLUTE THERMOMETER, ARMY'S PRIMARY AND SECONDARY REP.					SEP 79
3 78 3115G	REPEATABILITY STUDY OF LOW FLOW TURBINE METERS TESTS OF THE FLOW METERS FOR LONG TERM REPEATABILITY IS APPROXIMATELY 50 PERCENT COMPLETE AND WILL CONTINUE DURING THE NEXT REPORTING PERIOD.					DEC 79

S U M M A R Y P R O J E C T S T A T U S R E P O R T
 2ND SEMI-ANNUAL SUBMISSION CY 78 RCS DRCHT-301

PROJ NO.	TITLE + STATUS	AUTHORIZED VALUES (\$000)	EXPENDED LABOR AND MATERIAL (\$000)	ORIGINAL PROJECTED COMPLETE DATE	PRESENT PROJECTED COMPLETE DATE
3 78 3115H	<p>MODULAR EQUIPMENT CONFIGURATION FOR CALIBRATION + ANALYSIS</p> <p>THE ROTEK MODEL 600/650 CALIBRATOR AND AMPLIFIER HAS BEEN SUCCESSFULLY TESTED. THE ACCURACY, PARAMETERS AND LONG-TERM STABILITY HAVE BEEN FOUND TO BE WITHIN THE MFG SPEC. THIS EQUIP HAS THE POTENTIAL TO INCREASE PRODUCTIVITY OVER FIELDED EQUIP.</p>				DEC 79
3 78 3115I	<p>INSTRUMENT CONTROLLER SYSTEM</p> <p>ALL OF THE EQUIP ORDERED HAS BEEN RECEIVED AND THE INSTRUMENT CONTROLLER SYSTEM HAS BEEN IMPLEMENTED WITH 4 WORK STATIONS. THE SOFTWARE OPERATING SYSTEM IS CURRENTLY BEING USED AS A TIME-SHARED INSTRUMENT CONTROLLER VIA IEEE-488 INSTRUMENTATION BUS.</p>				DEC 79
3 78 3115M	<p>RF AND MW MEASUREMENTS STANDARDS</p> <p>THE DUAL SIX-PORT SYS HAS BEEN OUTFITTED WITH THERMISTOR MOUNT DETECTOR AND TYPE IV BRIDGES. AN INTEGRATED SIX-PORT IS BEING FABRICATED TO REPLACE THE DISCRETE COMPONENT CONFIGURATION NOW BEING USED.</p>				SEP 79
3 78 3115O	<p>TURBINE FLOWMETER DATA HANDLING UNIT</p> <p>A SCOPE OF WORK WAS PREPARED AND A CONTRACT WAS SEEN FINALIZED. DELIVERY IS SCHEDULED FOR JUNE OF 1979.</p>				SEP 79
3 78 3115P	<p>DYNAMIC MEASUREMENT AND STIMULI</p> <p>THE DAC-18 DIGITAL-TO-ANALOG CONVERTER HARDWARE CONSTRUCTION WAS COMPLETED. EXTENSIVE DYNAMIC TESTING WAS PERFORMED TO DETERMINE SETTLING TIME VS DUTY CYCLE AND REPETITION RATE.</p>				SEP 79
3 79 3115	<p>ENGINEERING FOR METROLOGY AND CALIBRATION</p> <p>THIS PROJECT WAS JUST FIUNDED. NO STATUS REPORT WAS REQUIRED.</p>	693.0			

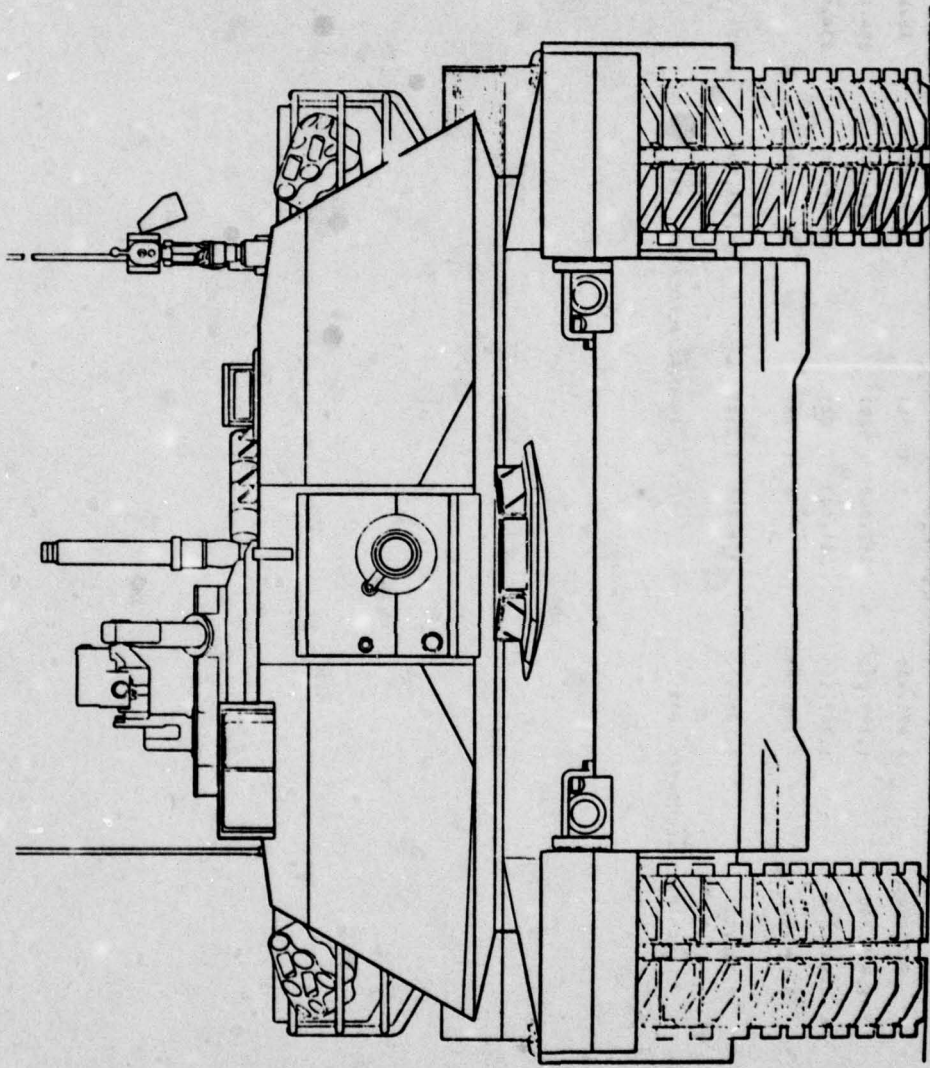

**TANK-AUTOMOTIVE R&D COMMAND
(TARADCOM)**

**TANK-AUTOMOTIVE MATERIEL READINESS COMMAND
(TARCOM)**

TANK-AUTO R&D COMMAND AND TANK-AUTO MATERIEL READINESS COMMAND
CURRENT FUNDING STATUS, 2ND CY78

FISCAL YEAR	NO. OF PROJECTS	AUTHORIZED FUNDS (\$)	CONTRACT FUNDS ALLOCATED (\$)	CONTRACT FUNDS EXPENDED (\$)	IMHOUSE FUNDS ALLOCATED (\$)	IMHOUSE FUNDS EXPENDED (\$)
76	2	450,000	127,000	127,000 (100%)	323,000	259,000 (80%)
77	1	500,000	473,400	0 (0%)	26,600	26,600 (100%)
77	5	1,575,000	1,159,000	612,000 (52%)	416,000	284,000 (68%)
78	12	4,367,000	1,367,100	31,000 (2%)	2,959,900	234,400 (7%)
79	19	5,170,000	140,000	0 (0%)	5,030,000	0 (0%)
TOTAL	39	12,042,000	3,286,500	770,000 (23%)	8,755,500	804,000 (9%)

AUTHORIZED FUNDING

CONTRACT ALLOCATED 27%

IMHOUSE ALLOCATED 72%

S U M M A R Y P R O J E C T S T A T U S R E P O R T
2ND SEMI ANNUAL SUBMISSION CY 78 RCS DRCHT-301

PROJ NO.	TITLE + STATUS	AUTHO- RIZED (\$000)	CONTRACT VALUES (\$000)	EXPENDED LABOR AND MATERIAL (\$000)	ORIGINAL PROJECTED COMPLETE DATE	PRESENT PROJECTED COMPLETE DATE
T 78 4264	TRACK INSERTS AND FILLERS FOR TRACK RUBBER PADS TRACK PADS HAVE BEEN FABRICATED AND SHIPPED TO YPG, THERE THEY WILL CONDUCT FIELD EVALUATION AND LAB ANALYSIS OF TRACK PADS.	200.0	15.2	27.4	JAN 81	JAN 81
T 79 4389	PON OF FOLDABLE PLASTIC TOPS FOR SOFT TOP TRUCK CAB- PH 1 THIS PROJECT WAS JUST FUNDED, NO STATUS REPORT WAS REQUIRED.	225.0				
4 76 4392	JOINING DISSIMILAR METALS-PHASE 2- SPECIMENS HAVE NOT BEEN SHIPPED TO APG, THIS PROJECT HAS BEEN DELAYED.	125.0		105.0	SEP 77	SEP 79
T 77 4557	PROD METHOD FOR HI EFFICIENCY JOINING OF ESR ARMOR-PHASE 2 TEST PLATES HAVE BEEN SHIPPED TO APG, ADDITIONAL WORK HAS BEEN PROGRAMMED.	150.0		142.0	DEC 78	MAR 79
4 76 4563	ROTATIONAL HOLDING OF LARGE CAPACITY FUEL TANKS. ALL TANKS RECD BY CONTRACT WERE MPD, BENCH TESTED AND DLVD. M551 AARAV TKS LEAKED AFTER 225 MILES OF ROAD TESTING, M88 HRV TKS ARE AWAITING INSTALLATION AND ROAD TESTING.	325.0	127.0	154.0	JUN 77	SEP 79
T 78 4575	LASER WELDING TECHNIQUES FOR MILITARY VEHICLES(PHASE I) CONTRACT HAS BEEN LET TO ITTRI, MATERIAL IS BEING PROCURED.	175.0	117.6	4.0	MAY 79	MAY 79
T 79 4575	LASER WELDING TECHNIQUES FOR MILITARY VEHICLES THIS PROJECT WAS JUST FUNDED, NO STATUS REPORT WAS REQUIRED.	375.0				
T 79 4500	IMPROVED LARGE ARMOR STEEL CASTINGS- PHASE 1 THIS PROJECT WAS JUST FUNDED, NO STATUS REPORT WAS REQUIRED.	900.0				
T 79 5002	FABRICATING TORSION SPRINGS FROM HIGH STRENGTH STEELS THIS PROJECT WAS JUST FUNDED, NO STATUS REPORT WAS REQUIRED.	150.0				
T 79 5006	PRODUCTION OF LIGHTWEIGHT STEEL CAST TRACK SHOES THIS PROJECT WAS JUST FUNDED, NO STATUS REPORT WAS REQUIRED.	200.0				
T 79 5007	ADVANCED TECHNOLOGY BRAKE LINING MATERIALS-PHASE 2 THIS PROJECT WAS JUST FUNDED, NO STATUS REPORT WAS REQUIRED.	190.0				
T 77 5014	IMPROVED FOUNDRY CASTINGS UTILIZING CAM A CONTRACT HAS BEEN AWARDED, THE INITIAL COMPUTER PROGRAM IS BEING SET UP.	560.0	490.0	36.0	SEP 79	OCT 79
T 78 5014	IMPROVED FOUNDRY CASTING UTILIZING CAM SEE STATUS FOR T 77 5014.	265.0	195.0		JAN 81	JAN 81

S U M M A R Y P R O J E C T S T A T U S R E P O R T
2ND SEMIANNUAL SUBMISSION CY 78 RCS DRCMT-301

PROJ NO.	TITLE + STATUS	AUTHORIZED (\$000)	CONTRACT VALUES (\$000)	EXPENDED LABOR AND MATERIAL (\$000)	ORIGINAL PROJECTED COMPLETE DATE	PRESNT PROJECTED COMPLETE DATE
4 78 5019	PLASTIC CONTAINER FOR LOW MAINTENANCE DRY CHARGED BATTERY PERFORMANCE TESTS ON PROTOTYPE PLASTIC CONTAINER GTN LOW MAINTENANCE BATTERIES BEGAN ON 4 DEC 78. PROTOTYPE BATTERIES HAVE BEEN SUBMITTED TO TECOM FOR FIELD PERFORMANCE EVALUATIONS.	160.0	155.0	155.0	SEP 79	SEP 79
T 78 5024	CAM GEAR DIE DESIGN AND MANUFACTURING PHASE 1. SEE PROJECT T 79 50249	200.0	160.0		JUN 80	JUN 80
T 79 5024	GEAR DESIGN + MFR UTILIZING COMPUTER TECHNOLOGY, CAM-PM 2 THE RFP HAS BEEN ISSUED TO PROSPECTIVE BIDDERS WITH A CLOSING DATE OF 15 JANUARY CONTRACT SELECTION IS EXPECTED BY 31 MAR 79.	205.0	140.0		JUN 80	JUN 80
T 79 5045	SPALL SUPPRESSIVE ARMOR FOR COMBAT VEHICLES-PHASE 1 THIS PROJECT WAS JUST FUNDED, NO STATUS REPORT WAS REQUIRED.	150.0				
T 79 5054	LASER SURFACE HARDENED COMBAT VEHICLE COMPONENTS-PHASE 1 THIS PROJECT WAS JUST FUNDED, NO STATUS REPORT WAS REQUIRED.	175.0				
T 78 5062	PRODUCTION OF ARMORED VEHICLE VISION BLOCKS AMRC CONSIDERED VARIOUS ADHESIVE PROCEDURES FOR COMBINING MATERIALS FOR HIGH BALLISTIC, LOW WEIGHT, VISION BLOCKS FOR ARMORED VEHICLES. AMRC IDENTIFIED CERAMIC TRANSPARENTIES FOR TEST, AND WILL BUY THEM FROM SUPPLIERS.	170.0	150.0	6.0	SEP 79	SEP 79
T 78 5064	LIGHT WEIGHT SADDLE TANK CONTRACT WAS AWARDED ON 29 SEP 1978. CONTRACTOR HAS MADE AN ENGINEERING ANALYSIS TO CONVERT ARMY DRAWINGS OF STEEL TANKS TO PROTOTYPE DRAWINGS UTILIZING ROTATIONAL MOLDING AS THE MANUFACTURING PROCESS.	90.0	34.0	13.0	APR 80	FEB 78
T 79 5064	LIGHT WEIGHT SADDLE TANK-PHASE 2 THIS PROJECT WAS JUST FUNDED, NO STATUS REPORT WAS REQUIRED.	140.0				
T 79 5067	PLASTIC BATTERY BOX THIS PROJECT WAS JUST FUNDED, NO STATUS REPORT WAS REQUIRED.	60.0				
T 79 5080	HIGH STRENGTH NEAR NET SHAPE ALUMINUM TRANSMISSION CASES THIS PROJECT WAS JUST FUNDED, NO STATUS REPORT WAS REQUIRED.	325.0				
T 79 5081	FABRICATION OF FRICTION RINGS AND REACTION PLATES- PHASE 2 THIS PROJECT WAS JUST FUNDED, NO STATUS REPORT WAS REQUIRED.	215.0				
T 79 5082	FLEXIBLE MACHINING SYSTEMS PILOT LINE FOR TCV COMPONENTS THIS PROJECT WAS JUST FUNDED, NO STATUS REPORT WAS REQUIRED.	440.0				

MANUFACTURING METHODS AND TECHNOLOGY PROGRAM
 S U M M A R Y P R O J E C T S T A T U S R E P O R T
 2ND SEMI-ANNUAL SUBMISSION CY 78 MCS DRMT-301

PROJ NO.	TITLE + STATUS	AUTHORIZED (\$000)	CONTRACT VALUES (\$000)	EXPANDED LABOR AND MATERIAL (\$000)	ORIGINAL PROJECTED COMPLETE DATE	PRESENT PROJECTED COMPLETE DATE
T 77 5083	UPSCALING OF ADVANCED POWDER METALLURGY PROCESSES ISOTHERMAL FORGING TEST COUPONS HAS BEEN INITIATED, COMPACTING, SINTERING, AND FORGING PROCEDURES WERE TENTATIVELY ESTABLISHED.	215.0	149.0	34.0	MAY 79	JUN 79
T 78 5083	UPSCALING OF ADVANCED POWDER METALLURGY PROCESSES CONTRACT WAS LET.	325.0	179.0	9.0	MAR 79	NOV 79
T 79 5083	UPSCALING OF ADVANCED POWDER METALLURGY PROCESSES-PH 3 THIS PROJECT WAS JUST FUNDED, NO STATUS REPORT WAS REQUIRED.	175.0				
T 77 5085	PRODUCTION TECHNIQUES / FABRICATION OF TURBINE RECUPERATOR PHASE I WORK COMPLETED AT ACCELERATED RATE AND LASER USE FOR PROD HAS BEEN VERIFIED. PHASE II PROCUREMENT ACTION HAS ENCOUNTERED A DELAY DUE TO NECESSITY OF CONDUCTING A RE-AUDIT.	400.0	309.0	34.0	NOV 78	JAN 80
T 78 5085	PRODUCTION TECHNIQUES FOR FABRICATION OF TURBINE RECUPERATOR PHASE I WORK COMPLETED AT ACCELERATED RATE AND LASER USE FOR PROD HAS BEEN VERIFIED. PHASE II PROCUREMENT ACTION HAS ENCOUNTERED A DELAY DUE TO NECESSITY OF CONDUCTING A RE-AUDIT.	485.0	450.0	4.0	JAN 80	JAN 80
T 79 5088	HIGH POWER ELECTRON BEAM WELDING IN AIR PHASE I THIS PROJECT WAS JUST FUNDED, NO STATUS REPORT WAS REQUIRED.	250.0				
T 79 5090	IMPROVED AND COST EFFECTIVE MACHINING TECHNOLOGY THIS PROJECT WAS JUST FUNDED, NO STATUS REPORT WAS REQUIRED.	315.0				
T 79 5094	ARMOR STEEL TREATED WITH RARE EARTH ADDITIONS THIS PROJECT WAS JUST FUNDED, NO STATUS REPORT WAS REQUIRED.	480.0				
T 77 5097	INTEGRALLY CAST LOW COST COMPRESSOR THE 5TH STAGE AXIAL WHEEL HAS BEEN REDESIGNED FOR CASTING AND THE INVESTMENT CASTING TOOLING HAS BEEN ORDERED.	250.0	211.0	36.0	JUN 79	MAY 79
T 78 5097	INTEGRALLY CAST LOW COST COMPRESSOR (PHASE II) A CONTRACT FOR PHASE II IS BEING NEGOTIATED.	250.0			JUN 80	OCT 80
T 79 6000	LIGHT WEIGHT TILT-UP HOOD FENDER ASSEMBLY-PHASE I THIS PROJECT WAS JUST FUNDED, NO STATUS REPORT WAS REQUIRED.	200.0				
T 78 6023	FABRICATION OF FLAT THIN GAGE ALLOY STEEL PLATE CONTRACT HAS BEEN LET TO US STEEL. ROLLED PLATE MATERIAL HAS BEEN PRODUCED FOR TWO THICKNESSES.	195.0	84.3	16.0	OCT 79	OCT 79
T 78 6035	ESTABLISH ON-LINE DNT FOR TRACKED COMBAT VEHICLES (PHASE I) ***** DELINQUENT STATUS REPORT *****	1,832.0				

MANUFACTURING METHODS AND TECHNOLOGY PROGRAM
 SUMMARY PROJECT STATUS REPORT
 2ND SEMI-ANNUAL SUBMISSION CY 78 RCS DRCHT-301

PROJ NO.	TITLE + STATUS	AUTHORIZED (\$000)	CONTRACT VALUES (\$000)	EXPENDED LABOR AND MATERIAL (\$000)	ORIGINAL PROJECTED COMPLETE DATE	PRESENT PROJECTED COMPLETE DATE
4 7T 4568	TECH DATA/CONFIGURATION MANAGEMENT SYSTEM (TD/CMS) CONTRACT ON PH 1 AWARDED IN JUN 78. INITIAL COMPUTER INPUT FOR BACKLOGGED ENGINEERING DOCUMENTATION WAS COMPLETED. PH 2 CONTRACT WAS AWARDED IN SEP 78. CONTRACTOR VISITED TARADCOM TO REVIEW PROGRAM PLANNING, AND OBJECTIVES FOR THE CONTRACT.	500.0	473.4	26.6	JUN 79	MAR 80

APPENDICES

APPENDIX I: Command Identification

APPENDIX I: ARMY ACTION COMMAND/ACTIVITY IDENTIFICATION

<u>Action Command</u>	<u>Acronym</u>	<u>First Digit of MMT Project Number</u>
Matériel Development & Readiness Command	DARCOM	D
Test & Evaluation Command	TECOM	0
Aviation R&D Command	AVRADCOM	1
Communications R&D Command	CORADCOM	F
Electronics R&D Command	ERADCOM	H
Communications & Electronics Command	CERCOM	2
Missile R&D Command	MIRADCOM	R
Missile MR Command	MIRCOM	3
Tank-Automotive R&D Command	TARADCOM	T
Tank-Automotive MR Command	TARCOM	4
Armament R&D Command (Munitions)	ARRADCOM (Ammo)	8
Armament MR Command (Munitions)	ARRCOM (Ammo)	5
Armament R&D Command (Weapons)	ARRADCOM (Wpns)	9
Armament MR Command (Weapons)	ARRCOM (Wpns)	6
Mobility Equipment R&D Command	MERADCOM	E
Army Materials and Mechanics Research Center	AMMRC	M
Natick R&D Command	NARADCOM	Q
Troop Support & Aviation Matériel Readiness Command	TSARCOM	7
NOTE: Abbreviation: R&D MR	Research and Development Matériel Readiness	

APENDIX II: User's Guide



U S A R M Y P R O J E C T S T A T U S R E P O R T
 1ST SEMIANNUAL SUBMISSION CY 78 RCB ORCMT-301
 MANUFACTURING METHODS AND TECHNOLOGY PROGRAM

PROJ NO.	TITLE + STATUS	AUTHORIZED	CONTRACT VALUES	EXPENDED LABOR AND MATERIAL	ORIGINAL PROJECTED COMPLETE DATE	PRESENT PROJECTED COMPLETE DATE
		(8000)	(8000)	(8000)		
5 78 6774	MFG METHOD FOR APDS PROJECTILE (28MM) INITIATED PRELIM CONTRACT FOR DEVELOPMENT OF 28MM PROJECTILE. S.O.W. DEVELOPED FOR PLASTIC SABOT.	300.0	150.0	30.2	NOV 79	NOV 79
5 77 6777	DEVELOPMENT OF PROD PROC- 105MM XM710E1 PROJECTILE METAL PTS CONTRACTOR HAS SUBMITTED A DRAFT FINAL REPORT.	500.0	49.8	340.9	MAR 78	JUN 78

(1) (2) (3)

(4)

(5)

(6)

(7)

(8)

(9)

THIS FORM IS USED FOR SUMMARIZING
 THE MMT PROGRAM PROJECTS STATUS.
 USER'S GUIDE BELOW EXPLAINS THE
 SIGNIFICANCE OF EACH COLUMN HEREIN.

USER'S GUIDE
to
SUMMARY PROJECT STATUS REPORT

COLUMN 1. PROJECT NUMBER

A project is identified by the first and last four digits which corresponds to the project title for the life of its execution. However, for accounting and reporting purposes, a project is recognized by the totality of its seven-digit numeral or alphanumeric number. Example:

3 75 6241

Project identifying number, which corresponds to the project title and is designated by action command.

Fiscal year of funding - the only two digits that may vary according to funding frequency (7T for FY transition).

Action command (see list accompanying Introduction).

COLUMN 2. Subtask identifier, if any.

COLUMN 3. PROJECT TITLE

The title descriptive of project effort.

COLUMN 4. STATUS

An abstract of project status taken from the Semiannual report. Whenever possible, technical accomplishments during the reporting period were summarized.

COLUMN 5. AUTHORIZED

The total amount of funds authorized in dollars, to complete the project.

COLUMN 6. CONTRACT VALUES

The portion of authorized funds actually expended or obligated for work performed by private industry.

COLUMN 7. EXTENDED LABOR AND MATERIAL

The portion of authorized funds actually expended or obligated in-house, namely within the Government.

COLUMN 8. ORIGINAL PROJECTED DATA OF COMPLETE

Calendar date clearly given in, or the nearest calendar month and year as could be read from the Milestone Chart of, the very first Project Status Report, RCS DRCMT-301.

COLUMN 9. PRESENT PROJECTED DATE OF COMPLETE

Calendar date clearly given in, or the nearest calendar month and year as could be read from the Milestone Chart of, the latest Project Status Report, RCS DRCMT-301.

APPENDIX III: Army MMT Program
Representatives

ARMY MM&T PROGRAM REPRESENTATIVES

HQ, DARCOM

US Army Materiel Development and Readiness Command

ATTN: DRCMT

5001 Eisenhower Avenue

Alexandria, VA 22333

C: 202 274-8284/8298

AV: 284-8284/8298

AVRADCOM

US Army Aviation Systems R&D Command

ATTN: DRDAV-EXT, Mr. Robert Vollmer

12th & Spruce Streets

St. Louis, MO 63166

C: 314 268-6476

AV: 698-6476

CERCOM

US Army Communications & Electronics Materiel Readiness Command

ATTN: DRSEL-LE-R, Mr. Martin Ides

Fort Monmouth, NJ 07703

C: 201 532-4950

AV: 992-4950

CORADCOM

US Army Communications R&D Command

ATTN: DRDCO-PPA-TP, Mr. Al Feddeler/Sam Esposito/Burton Resnic

Building 2700

Fort Monmouth, NJ 07703

C: 201 535-2418/4262/4026

AV: 995-2418/4262/4026

ERADCOM

US Army Electronics R&D Command

ATTN: DELET-DT, Mr. Joseph Key/Bernard Reich

Fort Monmouth, NJ 07703

C: 201 535-4258/4829

AV: 995-4258/4829

MIRADCOM

US Army Missile R&D Command

ATTN: DRDMI-EAT, Mr. Ray Farrison

Redstone Arsenal, AL 35809

C: 205 876-1835

AV: 746-1835

MIRCOM

US Army Missile Materiel Readiness Command

ATTN: DRSMI-NSS, Mr. Alfred H. James

Redstone Arsenal, AL 35809

C: 205 876-3025

AV: 746-3025

TARADCOM

US Army Tank-Automotive R&D Command

ATTN: DRDTA-KP, DRDTA-RCKM, Mr. J. Chevalier

Warren, MI 48090

C: 313 573-2065/1814/2467

AV: 273-2065/1814/2467

TARCOM

US Army Tank-Automotive Materiel Readiness Command

ATTN: DRSTA-EM, Ms. Vivian Buarkhalter

Warren, MI 48090

C: 313-573-2485

AV: 273-2485

ARRCOM

US Army Armament Materiel Readiness Command
ATTN: DRSAR-IRB, Mr. August Zahatko
Rock Island Arsenal
Rock Island, IL 61299

C: 309 794-4485/3730
AV: 793-4485/3730

ARRADCOM

US Army Armament R&D Command
ATTN: DRDAR-PML, Mr. Donald J. Fischer
Dover, NJ 07801

C: 201 328-6714/6715
AV: 880-6714/6715

TSARCOM

US Army Troop Support and Aviation Command
ATTN: DRSTS-PLE, Mr. Don G. Doll
4300 Goodfellow Blvd.
St. Louis, MO 63120

C: 314 268-3040
AV: 698-3040

MERADCOM

US Army Mobility Equipment R&D Command
ATTN: DRDME-UP, Mr. S. O. Newman
Fort Belvoir, VA 22060

C: 703 664-5530
AV: 354-5530

NARADCOM

US Army Natick R&D Command
ATTN: DRDNA-Z, Mr. Edward F. Levell
Natick, MA 01760

C: 617 653-1000, x2793/4
AV: 955-2349/2351

TECOM

US Army Test & Evaluation Command
ATTN: DRSTE-AD-M, Mr. Grover Shelton
Aberdeen Proving Ground, MD 21005

C: 301 278-3677
AV: 283-3677

AMMRC

US Army Materials & Mechanics Research Center
ATTN: DRXMR-PT, Mr. Raymond Farrow
Watertown, MA 02172

C: 617 923-3150
AV: 955-3150

HDL

Harry Diamond Laboratories
ATTN: DELHD-PP, Mr. Julius Hoke
2800 Powder Mill Road
Adelphi, MD 20783

C: 202 394-1551
AV: 290-1551

Rock Island Arsenal

ATTN: SARRI-ENM, Mr. Joseph DiBenedetto
Rock Island, IL 61299

C: 309 794-4627/4584
AV: 793-4627/4584

Watervliet Arsenal

ATTN: SARWV-PPI, Mr. L. A. Jette
Watervliet, NY 12189

C: 518 266-5318
AV: 794-5318

PM for Munitions Production Base Modernization and Expansion

ATTN: DRCPM-PBM-DP
Dover, NJ 07801

C: 201 328-6708
AV: 880-6708

AMRDL

US Army Air Mobility R&D Laboratories
ATTN: SAVDL-EU-TAS, Mr. L. Thomas Mazza
Fort Eustis, VA 23604

C: 804 878-5732
AV: 927-5732

IBEA

US Army Industrial Base Engineering Activity
ATTN: DRXIB-MT, Mr. James Carstens
Rock Island, IL 61299

C: 309 794-5113
AV: 793-5113

DCSRDA

ATTN: DAMA-CSM, Mr. Rod Vawter
Room 3C400, The Pentagon
Washington, DC 20310

C: 202 695-0506/07/08
AV: 225-0506/07/08

DCSRDA (PA 1497, Aircraft)

ATTN: DAMA-WSA, LTC Jay B. Bisbey
Room 3B454, The Pentagon
Washington, DC 20310

C: 202 695-1362
AV: 225-1362

DCSRDA (PA 2597, Missiles)

ATTN: DAMA-WSM-A, Mr. John Doyle
Room 3B485, The Pentagon
Washington, DC 20310

C: 202 695-8740
AV: 224-8740

DCSRDA (PA 3297, Weapons; PA 3197, Tracked Combat Vehicles)

ATTN: DAMA-WSW, MAJ Gordon Winder
Room 3D455, The Pentagon
Washington, DC 20310

C: 202 697-0106
AV: 227-0106

DCSRDA (PA 5297, Communications/Electronics)

ATTN: DAMA-CSC-BU, COL Higgins
Room 3D440, The Pentagon
Washington, DC 20310

C: 202 695-1881
AV: 225-1881

DCSRDA (Other Procurement Activities:

PA 5197, Tactical and Support Vehicles)
ATTN: DAMA-CSS-P, LTC L. R. Hawkins
Room 3D416, The Pentagon
Washington, DC 20310

C: 202 694-8720
AV: 224-8720

DCSRDA (Other Procurement Activities:

PA 5397, Other Support)
ATTN: DAMA-CSS-P, LTC P. K. Linscott
Room 3D418, The Pentagon
Washington, DC 20310

C: 202 694-8720
AV: 224-8720

DCSRDA (PA 4950, Ammunition)
ATTN: DAMA-CSM-DA, COL Jack King
Room 3C444, The Pentagon
Washington, DC 20310

C: 202 694-4330
AV: 224-4330

DCSRDA (PA 4950, Ammunition)
ATTN: DAMA-CSM-P, Mr. John Mytryshyn
Room 3C444, The Pentagon
Washington, DC 20310

C: 202 694-4330
AV: 224-4330

DRXIB-MT
DISTRIBUTION:

Defense Documentation Center:

Building 5, Cameron Station, Alexandria, VA 22314 (12 cys)

Department of Defense:

DIRSO, Cameron Station, Attn: Mr. Charles Downer (3 cys)
OUSD (R&D), The Pentagon, Attn: Dr. Lloyd L. Lehn (2 cys)

Department of the Army:

HQDA, OASARDA, The Pentagon, Attn: Mr. Eugene S. Davidson
HQDA, ODCSRDA, The Pentagon, Attn: DAMA-PPM-P, Mr. Rod Vawter

HQ DARCOM:

Cdr, DARCOM, Attn: DRCCG
Cdr, DARCOM, Attn: DRCDMD
Cdr, DARCOM, Attn: DRCDMR
Cdr, DARCOM, Attn: DRCP
Cdr, DARCOM, Attn: DRCP-I (3 cys)
Cdr, DARCOM, Attn: DRCD
Cdr, DARCOM, Attn: DRMT (20 cys)
Chf, Office of Project Management, Attn: DRCPM-PBM-P (5 cys)

Project/Product Managers:

PM, Advanced Attack Helicopter, Attn: DRCPM-AAH (AVRADCOM)
PM, Aircraft Survivability Equipment (ASE), Attn: DRCPM-ASE (AVRADCOM)
PM, Amphibians and Watercraft (AWC), Attn: DRCPM-AWC (TSARCOM)
PM, Armored Combat Vehicle Technology (ACVT), Attn: DRCPM-CVT (TARADCOM)
PM, Army Container-Oriented Distribution System (ACODS), Attn: DRCPM-CS (DARCOM)
PM, Army Tactical Communications Systems (ATAC), Attn: DRCPM-ATC (CORADCOM)
PM, Army Tactical Data Systems (ARTADS), Attn: DRCPM-TDS (CORADCOM)
PM, Automatic Test Support Systems, Attn: DRCPM-ATSS (CORADCOM)
PM, Blackhawk, Attn: DRCPM-BH (AVRADCOM)
PM, Cannon Artillery Weapons Systems, Attn: DRCPM-CAWS (ARRADCOM)
PM, CH-47 Mod. Program, Attn: DRCPM-CH47M (AVRADCOM)
PM, CHAPARRAL/FAAR, Attn: DRCPM-CF (MIRCOM)
PM, Chemical Demilitarization & Installation Restoration, Attn: DRCPM-DR (APG)
PM, COBRA, Attn: DRCPM-CO (TSARCOM)
PM, DCS (Army) Communications Systems, Attn: DRCPM-COM (ERADCOM)
PM, Division Air Defense (DIVAD) Gun, Attn: DRCPM-ADG (ARRADCOM)
PM, Family of Military Engr. Construc. Equip. (FAMECE)/Univsl. Engr. Tractor (UET), Attn: DRCPM-FM (MERADCOM)
PM, Fighting Vehicle Armament, Attn: DRCPM-FVA (TARADCOM)
PM, Fighting Vehicle Systems, Attn: DRCPM-FVS (TARADCOM)
PM, FIREFINDER, Attn: DRCPM-FF (ERADCOM)
PM, General Support Rocket System, Attn: DRCPM-RS (MIRADCOM)
PM, Ground Laser Designators, Attn: DRCPM-LD (MIRADCOM)
PM, HAWK, Attn: DRCPM-HA (MIRCOM)
PM, Heavy Equipment Transporter (HET), Attn: DRCPM-HT (TARCOM)
PM, Heliborne Laser Fire and Forget (HELLFIRE) Missile System, Attn: DRCPM-HE (MIRADCOM)

DRXIB-MT
DISTRIBUTION (Cont'd)

PM, High Energy Laser System, Attn: DRCPM-HEL (MIRADCOM)
PM, Improved TOW Vehicle, Attn: DRCPM-ITV (TARADCOM)
PM, LANCE, Attn: DRCPM-LC (MIRCOM)
PM, M60 Tank Development, Attn: DRCPM-M60TD (TARCOM)
PM, M60 Tank Production, Attn: DRCPM-M60TP (TARCOM)
PM, M110E2, 8-Inch Howitzer, Attn: DRCPM-M110E2 (ARRCOM)
PM, M113/M113A1 Family of Vehicle Readiness, Attn: DRCPM-M113 (TARCOM)
PM, Mobile Electric Power, Attn: DRCPM-MEP (Springfield, VA)
PM, Multi-Service Communications Systems, Attn: DRCPM-MSCS (CORADCOM)
PM, Navigation Control Systems (NAVCON), Attn: DRCPM-NC (ERADCOM)
PM, Nuclear Munitions, Attn: DRCPM-NUC (ARRADCOM)
PM, PATRIOT, Attn: DRCPM-MD (MIRADCOM)
PM, PERSHING, Attn: DRCPM-PE (MIRADCOM)
PM, Remotely Monitored Battlefield Sensor Systems (REMBASS), Attn: DRCPM-RBS (ERADCOM)
PM, 2.75 Rocket System, Attn: DRCPM-RK (MIRADCOM)
PM, SATCOM, Attn: DRCPM-SC (ERADCOM)
PM, Selected Ammunition, Attn: DRCPM-SA (ARRADCOM)
PM, Signal Intelligence/Electronic Warfare (SIGINT/EW), Attn: DRCPM-SIEW (CERCOM)
PM, Single Channel Ground and Airborne Radio Subsystem (SINCGARS), Attn: DRCPM-GARS (CORADCOM)
PM, Smoke/Obscurants (SMOKE), Attn: DRCPM-SMK (APG)
PM, Special Electronic Mission Aircraft (SEMA), Attn: DRCPM-AE (TSARCOM)
PM, Stand-off Target Acquisition System, Attn: DRCPM-STA (ERADCOM)
PM, STINGER, Attn: DRCPM-MP (MIRADCOM)
PM, TOW-DRAGON, Attn: DRCPM-DT (MIRCOM)
PM, Training Devices, Attn: DRCPM-TND (Orlando, FL)
PM, US ROLAND, Attn: DRCPM-ROL (MIRADCOM)
PM, VIPER, Attn: DRCPM-VI (MIRADCOM)
PM, XM-1 Tank System, Attn: DRCPM-GCM (TARADCOM)

Project Officers:

PO, Joint Services Interior Intrusion Detection System (J-SIIDS), Attn: DRSTS-KJ
PO, M60A1 Tank Camouflage Pilot Program, Attn: DRXFB-RT
PO, SLUF AE/SLUMINE, Surface Launch Unit Fuel Air Explosive (SLUF AE) Mine Neutralization System/Surface Launched Unit Mine (SLUMINE) Dispensing System, Attn: DRDME-NS (Ft. Belvoir)
PO, Stand-Off Target Acquisition/Attack System (SOTAS), Attn: DRSEL-CT
PO, Test, Measurement, and Diagnostic Equipment, Attn: DRCRE-T (DARCOM)
PO, Tactical Shelters, Attn: DRXNM-UBS

Major Subcommands:

Cdr, ARRCOM, Attn: DRSAR-CG
Cdr, ARRADCOM, Attn: DRDAR
Cdr, ARRADCOM, Attn: DRDAR-TDA, Mr. Joe Blick
Cdr, AVRADCOM, Attn: DRDAV
Cdr, CERCOM, Attn: DRSEL

DRXIB-MT
DISTRIBUTION (Cont'd)

Major Subcommands (Cont'd):

Cdr, CORADCOM, Attn: DRDCO-PE-EC-I, Mr. Stan Sokolove
Cdr, DESCOM, Attn: DRSDS-PMI, Mr. Allen Updegrave
Cdr, ERADCOM, Attn: DELET
Cdr, MIRCOM, Attn: DRSMI
Cdr, MIRADCOM, Attn: DRDMI
Cdr, TARADCOM, Attn: DRDTA
Cdr, TARCOM, Attn: DRSTA
Cdr, TECOM, Attn: DRSTE
Cdr, TSARCOM, Attn: DRSTS
Cdr, MERADCOM, Attn: DRDME
Cdr, NARADCOM, Attn: DRDNA
Dir, USAILCOM, Attn: DRCIL

Arsenals:

Cdr, Pine Bluff Arsenal (PBA), Attn: SARPB
Cdr, Rock Island Arsenal (RIA), Attn: SARRI-CO
Cdr, Rocky Mountain Arsenal (RMA), Attn: SARRM
Cdr, Watervliet Arsenal (WVA), Attn: SARWV

Army Ammunition Plants:

Cdr, Crane AAP, Attn: SARCN
Cdr, Hawthorne AAP, Attn: SARHW
Cdr, Holston AAP, Attn: SARHO
Cdr, Indiana AAP, Attn: SARIN
Cdr, Iowa AAP, Attn: SARIO
Cdr, Kansas AAP, Attn: SARKA
Cdr, Lake City AAP, Attn: SARLC
Cdr, Lone Star AAP, Attn: SARLS
Cdr, Longhorn AAP, Attn: SARLO
Cdr, Louisiana AAP, Attn: SARLA
Cdr, McAlester AAP, Attn: SARMC
Cdr, Milan AAP, Attn: SARMI
Cdr, Mississippi AAP, Attn: SARMS
Cdr, Radford AAP, Attn: SARRA
Cdr, Riverbank AAP, Attn: SARRB
Cdr, Scranton AAP, Attn: SARSC

Depots:

Cdr, Anniston Army Depot, Attn: SDSAN
Cdr, Corpus Christi Army Depot, Attn: SDSCC
Cdr, Letterkenny Army Depot, Attn: SDSLE
Cdr, New Cumberland Army Depot, Attn: SDSNC
Cdr, Red River Army Depot, Attn: SDSRR
Cdr, Sacramento Army Depot, Attn: SDSSA
Cdr, Seneca Army Depot, Attn: SDSSE
Cdr, Sharpe Army Depot, Attn: SDSSH

DRXIB-MT
DISTRIBUTION (Cont'd)

Depots (Cont'd):

Cdr, Sierra Army Depot, Attn: SDSSI
Cdr, Tobyhanna Army Depot, Attn: SDSTO
Cdr, Tooele Army Depot, Attn: SDSTE

Depot Activities:

Cdr, Lexington-Blue Grass Army Depot Activity, Attn: SDSLX
Cdr, Navajo Army Depot Activity, Attn: DRXTE-N
Cdr, Pueblo Army Depot Activity, Attn: DRXPU
Cdr, Savanna Army Depot Activity, Attn: DRSAC
Cdr, Umatilla Army Depot Activity, Attn: DRXTE-UM
Cdr, Fort Wingate Army Depot Activity, Attn: DRXFW

DARCOM Labs, Schools, and Other Army Installations/Activities:

Cdr, Army Ballistic Research Labs (BRL), Attn: DRXBR-X
Cdr, Army Equipment Authorizations Review Acty. (EARA), Attn: DRXEA-C
Cdr, Army Harry Diamond Labs (HDL), Attn: DRXD0
Dir, Army Human Engineering Labs (HEL), Attn: DRXHE
Cdr, Army Logistics Management Ctr. (ALMC), Attn: DRXMC-AL
Cdr, Army Maintenance Management Ctr., Attn: DRXMD
Dir, Army Management Engineering Training Acty. (AMETA), Attn: DRXOM
Dir, Army Materials and Mechanics Research Ctr. (AMMRC), Attn: DRXMR,
DRXMR-M (3 cys)
Cdr, Army Research Office (ARO), Attn: DRXRO-A0
Cdr, Army Weapons Support Ctr, Crane, IN 47522
Dir, Automated Logistics Management Systems Acty. (ALMSA), Attn: DRXAL-A
Cdr, Foreign Science and Technology Ctr. (FSTC), Attn: DRXST-OC
Dir, Installations and Services Activity (I&SA), Attn: DRCIS
Cdr, Joint Military Packing Training Ctr., Attn: DRXPP-A
Cdr, Logistics System Support Acty. (LSSA), Attn: DRXLS-L
Cdr, Night Vision Labs (NVL), Attn: DRSEL-NV-PA/IO

MT Representatives:

Cdr, ARRADCOM, Attn: DRDAR-PML, Mr. Donald J. Fischer (7 cys)
Cdr, ARRCOM, Attn: DRSAR-IRB, Mr. August Zahatko (4 cys)
Cdr, AVRADCOM, Attn: DRDAV-EXT, Mr. Robert Vollmer
Cdr, CERCOM, Attn: DRSEL-LE-R, Mr. Martin Ides
Cdr, CORADCOM, Attn: DRDCO-PPA-TP, Mr. Al Feddeler, Sam Esposito, Burton Resnic
Cdr, ERADCOM, Attn: DELET-DT, Mr. Joseph Key, Attn: DELET-R, Mr. Bernard Reich
Cdr, MERADCOM, Attn: DRDME-UP, Mr. S. O. Newman
Cdr, MIRADCOM, Attn: DRDMI-EAT, Mr. Ray Farrison
Cdr, MIRCOM, Attn: DRSMI-NSS, Mr. Alfred H. James
Cdr, NARADCOM, Attn: DRDNA-EM, DRDNA-Z, Mr. Edward F. Levell
Cdr, TARADCOM, Attn: DRDTA-KP, DRDTA-RCKM, Mr. J. Chevalier
Cdr, TARCOM, Attn: DRSTA-EM
Cdr, TECOM, Attn: DRSTE-AD-M, Mr. Glover Shelton
Cdr, TSARCOM, Attn: DRSTS-PLE, Mr. Don G. Doll
Dir, AMMRC, Attn: DRXMR-E, DRXMR-PT, Mr. Raymond Farrow
Cdr, HDL, Attn: DELHD-PP, Mr. Julius Hoke

DRXIB-MT
DISTRIBUTION (Cont'd)

MT Representatives (Cont'd):

Cdr, AMRDL, Attn: SAVDL-EU-TAS, Mr. L. Thomas Mazza
Cdr, RIA, Attn: SARRI-ENM, Mr. Joseph DiBenedetto
Cdr, WVA, Attn: SARWV-PPI, Mr. L. A. Jette
PM, MPBM&E, Attn: DRCPM-PBM-DP
DCSRDA, Attn: DAMA-WSA, LTC Jay B. Bisbey
DCSRDA, Attn: DAMA-WSM-A, Mr. John Doyle
DCSRDA, Attn: DAMA-WSW, MAJ Gordon Winder
DCSRDA, Attn: DAMA-CSC-BU, COL Higgins
DCSRDA, Attn: DAMA-CSS-P, LTC L. R. Hawkins, LTC P. K. Linscott
DCSRDA, Attn: DAMA-CSM-P, Mr. John Mytryshyn
DCSRDA, Attn: DAMA-CSM-DA, COL Jack King

Navy Activities:

Cdr, NAVMAT, Attn: CPT L. C. Dittmar, Code 044
Cdr, NAVMIRO, Attn: Officer-In-Charge
Cdr, NAVSEA, Attn: T. E. Draschil, Code C-0354
Cdr, NAVAIR, Attn: D. S. Henderson, Code ESA-824
Cdr, NAVELEX, Attn: C. A. Rigdon, Code ELEX-504512
Cdr, Naval Surface Weapons Ctr/White Oak Lab, Attn: Code CM-42
Cdr, Naval Surface Weapons Ctr/Dahlgren Lab, Attn: Code CM-51
Cdr, Naval Weapons Ctr, Attn: D. M. Bullat, Code 36804

Air Force Activities:

Cdr, HQ, USAF/RDXI, The Pentagon, Attn: MAJ D. Mackintosh
Cdr, AFSC/DLF, Andrew AFB
Cdr, AFSC/DLFF, Andrew AFB
Cdr, AFSC/PPD, Andrew AFB
Cdr, AFSC/PPDE, Andrew AFB
Cdr, AFML/LT, Wright-Patterson AFB
Cdr, AFML/LTE, /LTM, /LTN, Wright-Patterson AFB
Cdr, AFML/MX, Wright-Patterson AFB
Cdr, San Antonio Air Logistics Ctr, Kelly AFB, Attn: E. Boisvert, MMEWA