

AEDC-TR-78-74

cy.3

APR 26 1979

JUL 6 1979

AUG 26 1983

MAY 2 1986

EVALUATION OF A SELF-CALIBRATING SILICON BOLOMETER

P. W. Belew and F. G. Sherrell
ARO, Inc., a Sverdrup Corporation Company

**VON KARMAN GAS DYNAMICS FACILITY
ARNOLD ENGINEERING DEVELOPMENT CENTER
AIR FORCE SYSTEMS COMMAND
ARNOLD AIR FORCE STATION, TENNESSEE 37389**

TECHNICAL REPORTS April 1979
FILE COPY

Final Report for Period 1 October 1977 — 30 September 1978

Approved for public release; distribution unlimited.

Property of U. S. Air Force
AEDC LIBRARY
F40600-77-C-0003

Prepared for

**ARNOLD ENGINEERING DEVELOPMENT CENTER/DOTR
ARNOLD AIR FORCE STATION, TENNESSEE 37389**

NOTICES

When U. S. Government drawings, specifications, or other data are used for any purpose other than a definitely related Government procurement operation, the Government thereby incurs no responsibility nor any obligation whatsoever, and the fact that the Government may have formulated, furnished, or in any way supplied the said drawings, specifications, or other data, is not to be regarded by implication or otherwise, or in any manner licensing the holder or any other person or corporation, or conveying any rights or permission to manufacture, use, or sell any patented invention that may in any way be related thereto.

Qualified users may obtain copies of this report from the Defense Documentation Center.

References to named commercial products in this report are not to be considered in any sense as an indorsement of the product by the United States Air Force or the Government.

This report has been reviewed by the Information Office (OI) and is releasable to the National Technical Information Service (NTIS). At NTIS, it will be available to the general public, including foreign nations.

APPROVAL STATEMENT

This report has been reviewed and approved.



MARSHALL K. KINGERY
Project Manager, Research Division
Directorate of Test Engineering

Approved for publication:

FOR THE COMMANDER



ROBERT W. CROSSLEY, Lt Colonel, USAF
Acting Director of Test Engineering
Deputy for Operations

UNCLASSIFIED

REPORT DOCUMENTATION PAGE		READ INSTRUCTIONS BEFORE COMPLETING FORM
1. REPORT NUMBER AEDC-TR-78-74	2. GOVT ACCESSION NO.	3. RECIPIENT'S CATALOG NUMBER
4. TITLE (and Subtitle) EVALUATION OF A SELF-CALIBRATING SILICON BOLOMETER		5. TYPE OF REPORT & PERIOD COVERED Final Report, 1 Oct 1977 - 30 Sept 1978
		6. PERFORMING ORG. REPORT NUMBER
7. AUTHOR(s) P. W. Belew and F. G. Sherrell, ARO, Inc., a Sverdrup Corporation Company		8. CONTRACT OR GRANT NUMBER(s)
9. PERFORMING ORGANIZATION NAME AND ADDRESS Arnold Engineering Development Center Air Force Systems Command Arnold Air Force Station, Tennessee 37389		10. PROGRAM ELEMENT, PROJECT, TASK AREA & WORK UNIT NUMBERS Program Element 65807F
11. CONTROLLING OFFICE NAME AND ADDRESS Arnold Engineering Development Center/OIS Air Force Systems Command Arnold Air Force Station, Tennessee 37389		12. REPORT DATE April 1979
		13. NUMBER OF PAGES 29
14. MONITORING AGENCY NAME & ADDRESS (if different from Controlling Office)		15. SECURITY CLASS. (of this report) UNCLASSIFIED
		15a. DECLASSIFICATION/DOWNGRADING SCHEDULE N/A
16. DISTRIBUTION STATEMENT (of this Report) Approved for public release; distribution unlimited.		
17. DISTRIBUTION STATEMENT (of the abstract entered in Block 20, if different from Report)		
18. SUPPLEMENTARY NOTES Available in DDC.		
19. KEY WORDS (Continue on reverse side if necessary and identify by block number) bolometers calibration blackbody radiation infrared radiation		
20. ABSTRACT (Continue on reverse side if necessary and identify by block number) A blackbody radiation source was used to evaluate a self-calibrating, phosphorous-doped silicon bolometer, with the objective of establishing an NBS-traceable calibration of the bolometer. The experimental results are inconclusive, since the response of the bolometer to its integral thin-film heater power was found to be linear and the response to the NBS-calibrated blackbody power was not linear. This discrepancy		

UNCLASSIFIED

UNCLASSIFIED

20. ABSTRACT (Continued)

suggests the possible existence of a blackbody design problem. The problem should be resolved by repeating the calibration using another NBS-calibrated infrared source.

PREFACE

The work reported herein was conducted by the Arnold Engineering Development Center (AEDC), Air Force Systems Command (AFSC). The Air Force project manager was Mr. Marshall Kingery. The results of the research presented were obtained by ARO, Inc., AEDC Division (a Sverdrup Corporation Company), operating contractor for the AEDC, AFSC, Arnold Air Force Station, Tennessee, under ARO Project Number V32S-R0A. The manuscript was submitted for publication on November 2, 1978.

CONTENTS

	<u>Page</u>
1.0 INTRODUCTION	5
2.0 APPARATUS	6
2.1 Test Cell	6
2.2 Bolometer	6
2.3 Bias Supply and Signal Preamplifier	8
2.4 University of Arizona Blackbody	10
3.0 PARAMETER DEFINITIONS AND EXPERIMENTAL PROCEDURES	
3.1 Theoretical Responsivity	12
3.2 Responsivity to Heater Power	14
3.3 Responsivity to Radiometric Power	15
4.0 CALIBRATION DATA	17
5.0 DISCUSSION OF RESULTS	23
6.0 CONCLUSIONS	27
REFERENCES	27

ILLUSTRATIONS

Figure

1. Infrared Source Testing Chamber	6
2. Cross-Sectional View of Bolometer Mounting Hardware	7
3. Cross-Sectional View of Self-Calibrating Bolometer	8
4. Bolometer Instrumentation System Schematic	9
5. Cross-Sectional View of University of Arizona Blackbody	11
6. Experimental Load Curve	13
7. Bolometer Response as a Function of Bias Current	14
8. Bolometer Response to Heater Input Power	16
9. Bolometer Response to Radiometric Power, Run 1	24
10. Bolometer Response to Radiometric Power, Run 2	25
11. Bolometer Response to Radiometric Power, Run 3	26

TABLES

	<u>Page</u>
1. Run 1 Data	19
2. Run 2 Data	20
3. Run 3 Data	21
4. Responsivity Variation with Blackbody Temperature	22
 NOMENCLATURE	 28

1.0 INTRODUCTION

The von Kármán Gas Dynamics Facility (VKF) Aerospace Chamber (7V) at the Arnold Engineering Development Center (AEDC) is equipped to test long wavelength infrared (LWIR) sensors. It is a 7-ft-diam by 12-ft-long, high-vacuum chamber containing a light-tight 20°K liner. A pinhole radiation source located at the focal point of a 28-in.-diam., spherical collimating mirror is the infrared target simulator. Sensor calibrations require that the pinhole radiation source be well defined and calibrated.

Typically, the pinhole radiation source consists of a small circular orifice in a 20°K, thin-wall aperture plate. A blackbody cavity located behind the orifice provides the infrared radiation. In principle, the radiation from the orifice may be calculated from the Stefan-Boltzmann Law if the orifice area, cavity temperature, and cavity emittance are known. Since these parameters are fairly easy to determine, such calculations are commonplace. However, these calculations often prove to be unreliable because of stray radiation or systematic errors in cavity temperature measurements.

To prove that a source is operating in accordance with the Stefan-Boltzmann Law requires the direct measurement of output infrared radiation. However, this measurement requires the use of a rather special cryogenic, infrared bolometer.

A self-calibrating, phosphorous-doped, silicon bolometer was supplied by the Molecron Corporation to be used in the calibration of infrared sources (Ref. 1). A description of the initial application of the bolometer in testing cryogenic infrared sources is presented in Ref. 2. The results of the work reported in Ref. 2 indicated that the Molecron bolometer was not completely self-calibrating and that the bolometer should be calibrated against a standard, NBS-calibrated, low temperature blackbody.

In 1972 a development contract was issued to the Optical Sciences Center of the University of Arizona (UA) to build a low temperature blackbody simulator (Ref. 3). In 1977, the UA blackbody was calibrated by the National Bureau of Standards and delivered to the AEDC.

This report describes an application of the UA blackbody, with the objective of obtaining an NBS-traceable calibration of the Molecron bolometer. A description of the hardware employed is presented along with the results of the test.

2.0 APPARATUS

2.1 TEST CELL

Figure 1 is a schematic representation of the cell used in testing and calibrating infrared sources. It consists of a 24-in.-diam outer shell and an 18-in.-diam by 30-in.-long inner liner. The inner liner is continuously cooled by flowing 20°K helium gas through attached copper tubing. Access to the inner liner is through removable end panels which are also cooled with 20°K helium gas. The liner is covered with several layers of aluminized Mylar[®] to reduce the radiation load on the 20°K helium refrigerator. A detailed description of the test chamber can be found in Ref. 2.

2.2 BOLOMETER

The Molecron bolometer is mounted on a helium dewar (Fig. 1) that is cooled to approximately 1.5°K by pumping on the liquid helium with a 13-cfm rotary pump to reduce the helium vapor pressure. Figures 2 and 3 are cross-sectional views of the bolometer mounting hardware and the bolometer chip. A thin-film heater is deposited on one side of the 5- by 5-mm bolometer chip, and that side is coated with black paint (Ref. 1). It is that side of the bolometer which is exposed to and absorbs incident radiation. Therefore, the bolometer chip may be heated electrically with the thin-film heater or radiometrically by absorbing incident infrared radiation. The reverse side of the silicon chip is doped with phosphorous to create the active bolometric region (Ref. 1). The middle region of the bolometer is electrically insulating at cryogenic temperatures, but it conducts heat readily from the front, heated surface to the rear, bolometric surface. The temperature of the bolometer increases slightly when either radiant or electrical power is applied, and at the 1.5°K operating temperature, a slight temperature rise causes the resistance of the bolometric region to drop sharply. A constant bias current is passed through the bolometric region, and the bolometer signal is registered as the change in the IR drop across the bolometric region as the bolometer is heated.

The original concept of using the Molecron bolometer for infrared source calibrations required that the bolometer be calibrated with its integral, thin-film heater. The heater was then to be turned off and the infrared source turned on and measured. More details on this basic concept are presented in Refs. 1 and 2.

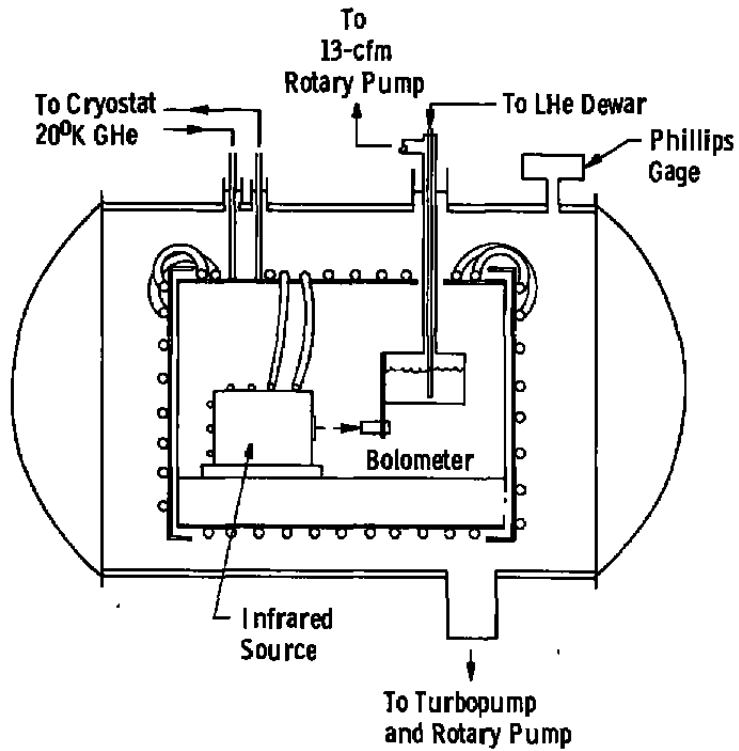

Figure 1. Infrared source testing chamber.

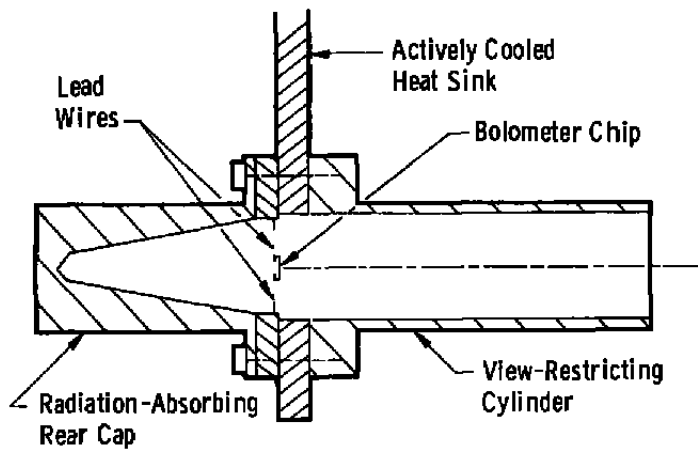

Figure 2. Cross-sectional view of bolometer mounting hardware.

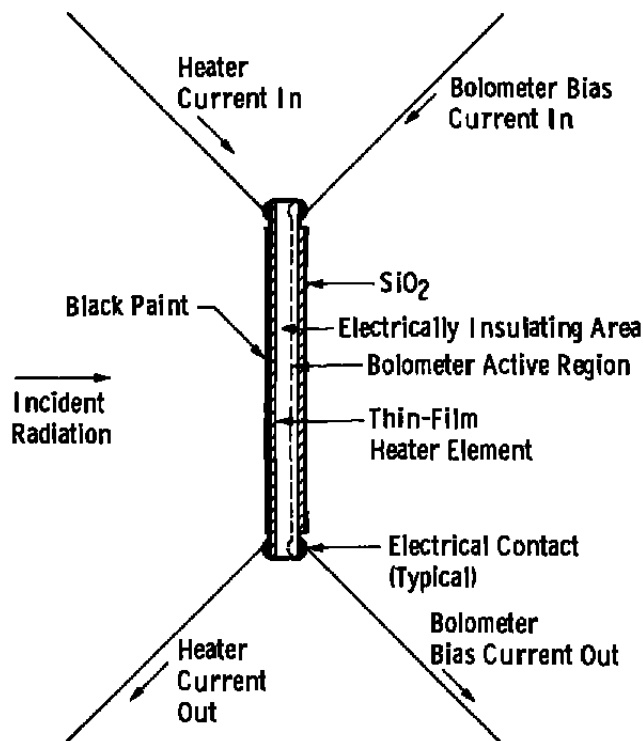

Figure 3. Cross-sectional view of self-calibrating bolometer.

2.3 BIAS SUPPLY AND SIGNAL PREAMPLIFIER

In order to minimize 60-Hz noise pickup encountered previously (Ref. 2), the MOSFET preamplifier was moved from the 20°K liner to the 1.5°K liquid helium dewar. At the same time, a new bias supply was designed and fabricated to allow the grounding of one side of the bolometer at the dewar. Figure 4 is a schematic of the new bolometer instrumentation system, which is free of 60-Hz noise.

The bolometer is operated at a constant bias current that is generated and stabilized by Op-Amp 1, shown in Fig. 4. The 1-M Ω resistor, which is in series with the 2-M Ω load resistor, senses the bias current, I . One volt is developed across the sensing resistor for each microamp of bias current. The total bias voltage applied, E_A , is measured at the output of Op-Amp 1, but the actual bias voltage, E_B , across the bolometer is

$$E_B = E_A - (3M\Omega)(I) \quad (1)$$

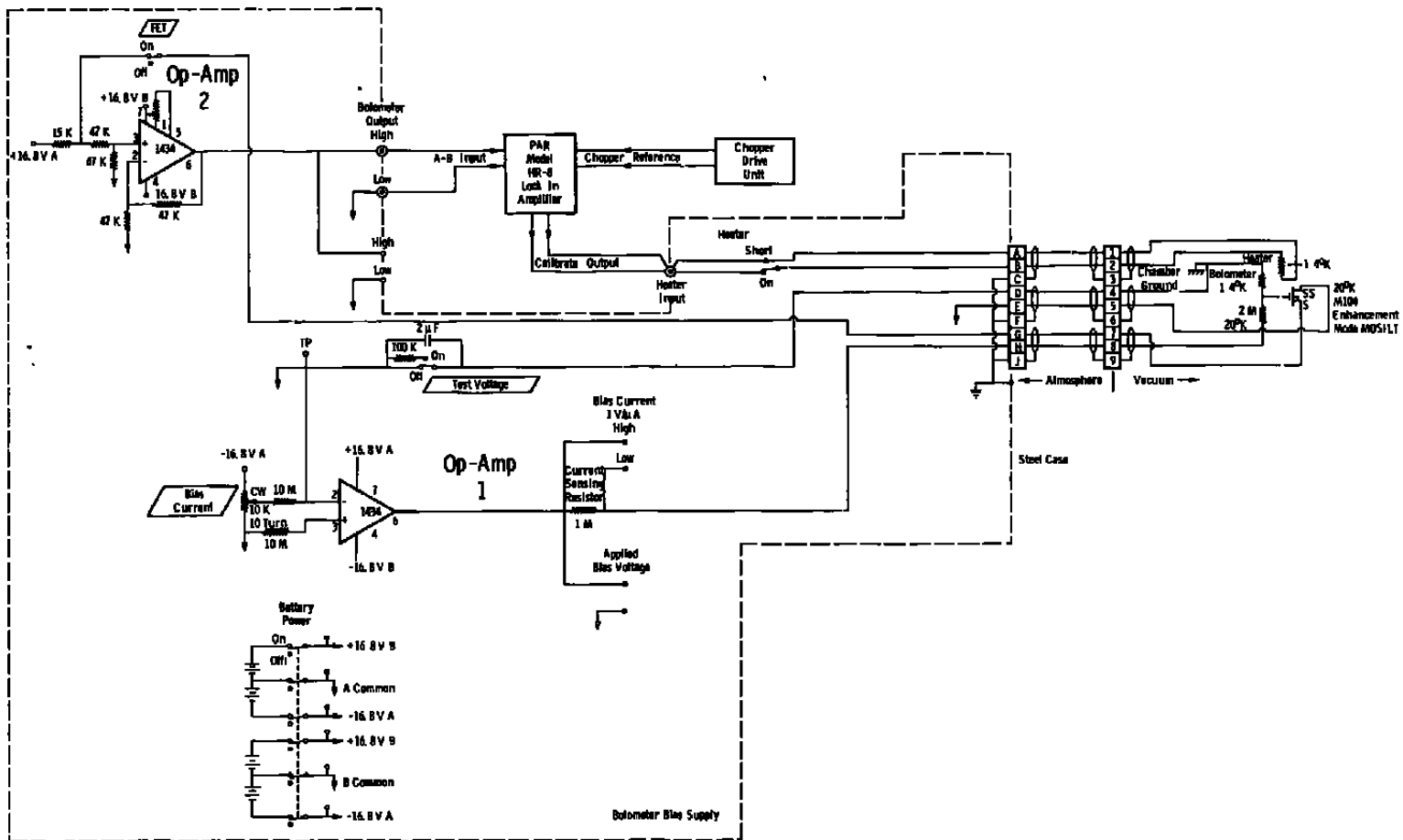

Figure 4. Bolometer instrumentation system schematic.

It is this voltage, E_B , which changes when the bolometer is heated. A change in E_B generates a change in the M104 MOSFET source current. This, in turn, causes a voltage change on the input to Op-Amp 2. Op-Amp 2 serves as an output voltage follower. Therefore, the bolometer signal preamplifier consists of the M104 MOSFET in combination with Op-Amp 2. A test voltage switch places an additional 100 K Ω in series with the bolometer. Switching this resistor in and out artificially simulates bolometer heating and produces a test voltage, V_T , which is used to measure the gain of the bolometer signal preamplifier. Test voltage, V_T , defined as

$$V_T = (100 \text{ K}\Omega) I \quad (2)$$

would be the output of Op-Amp 2 if the preamplifier gain were unity. For example, the bias current was set to 0.25 μA and the 100 K Ω was switched in. The output of Op-Amp 2 changed by 21 mV. However, from the expression above, V_T is 25 mV; thus, the gain of the preamplifier is 0.84. As shown in Section 3.1, this gain must be taken into account in order to determine absolute responsivity of the bolometer.

2.4 UNIVERSITY OF ARIZONA BLACKBODY

The University of Arizona blackbody is a spherical, high emittance cavity radiator developed by the Optical Sciences Center at the University of Arizona. A cross-sectional view is given in Fig. 5.

Two concentric aluminum cylinders shield the heated aluminum core which contains the spherical cavity. The inner shield contains a precision orifice (0.02905-in. diam), and the outer shield contains a clearance aperture for the radiation leaving the cavity. The inside of the sphere has been anodized and dyed black. Except for the heated core, all components of the assembly are cooled to 20°K during operation.

AWG-25 Nichrome[®] wire is wrapped spirally around the core at a spacing of 24 turns per inch to form the heater. The heater wire is electrically insulated from the core by the hard anodized surface and a fiberglass sheath. A coating of Rust-Oleum[®] Type 4272 black paint was applied to increase thermal conduction.

The blackbody is equipped with three 4-terminal platinum resistance thermometers (PRT's) which are cemented with Sermetel PBX[®] into wells drilled in the heater core. Rosemount Engineering Company supplied a calibration of the PRT's resistance values over the temperature range from 75 to 775°K in 10-deg increments. One of the PRT's is used for automatic temperature control, and the other two are used to monitor the core temperature.

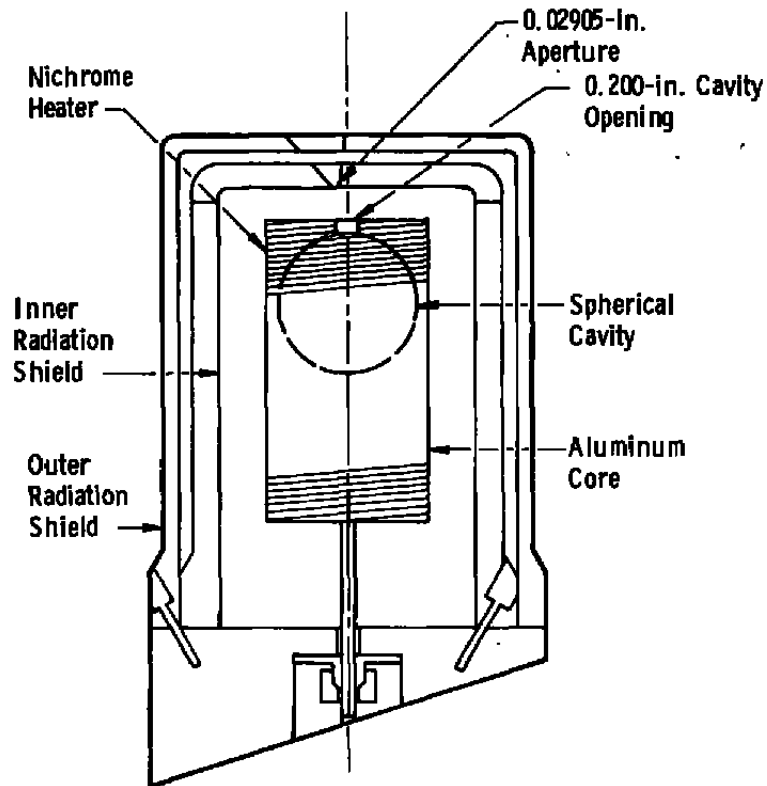

Figure 5. Cross-sectional view of University of Arizona blackbody.

Upon calibration of the blackbody at the NBS, a discrepancy was noted between the indicated temperature, T_I , from the Rosemount calibrations, and the actual radiometric temperature, T_R , of the blackbody. The two were related by an equation of the following form:

$$T_R = A + (1 + B)T_I \quad (3)$$

The coefficients

$$A = -33.2584^\circ\text{K}$$

and

$$B = 0.110629$$

were determined at the NBS from a least squares fit to 68 data points.

It should be noted that a well-designed and properly fabricated blackbody radiation source will exhibit radiometric and indicated temperatures that are in agreement.

3.0 PARAMETER DEFINITIONS AND EXPERIMENTAL PROCEDURES

Response characteristics of the bolometer are defined in this section. There are three bolometer responsivities of interest: (1) the theoretical responsivity determined from the experimental load curve; (2) the responsivity to electrical power; and (3) the responsivity to incident radiant blackbody power.

3.1 THEORETICAL RESPONSIVITY

A typical experimental load curve is presented in Fig. 6. A load curve is merely a plot of the bias current through the bolometric region of the bolometer as a function of the voltage drop across it. Load curve data were obtained with the MOSFET both on and off; however, normal operation is with the MOSFET on. The difference between the two load curves is significant in that it shows a heating effect on the bolometer due to the power injected into the MOSFET. In future exercises, the MOSFET will be better thermally sunk to the helium dewar and should have less effect on the bolometer load curve.

The theoretical responsivity as defined by Jones in Ref. 4 is

$$R_T = \frac{Z - R}{2IR} = \frac{Z - R}{2E_B} \quad (4)$$

where R is the bolometer resistance at the operating point, I is the bias current at the operating point, and Z is the "dynamic resistance" or slope, $\Delta E_B / \Delta I$, of the tangent to the load curve at the operating point. On the basis of the load curve of Fig. 6, taken at 1.42°K, the Jones theoretical responsivity with the MOSFET on was 1.2×10^6 V/W. Since the preamplifier has a gain of 0.84, the theoretical responsivity at the amplifier output becomes 1.01×10^6 V/W. As will be shown in Sections 3.2 and 3.3, this theoretical responsivity is higher than the bolometer responsivity to either heater or radiometric power.

The preferred operating point on the load curve is chosen by determining the bias current at which peak bolometer response occurs. To accomplish this, the calibrate output voltage from a Princeton Applied Research (PAR) Model HR-8 lock-in amplifier was applied to the bolometer heater and the resulting bolometer output signal was measured with the HR-8 as the bias current was adjusted from 0.1 to 1.4 μ A (Fig. 7). This was done for each

data run, and the bias current at which peak response occurred was used to measure the radiometric response to the UA blackbody. Peak response usually occurred around 0.25 to 0.30 μA of bias current.

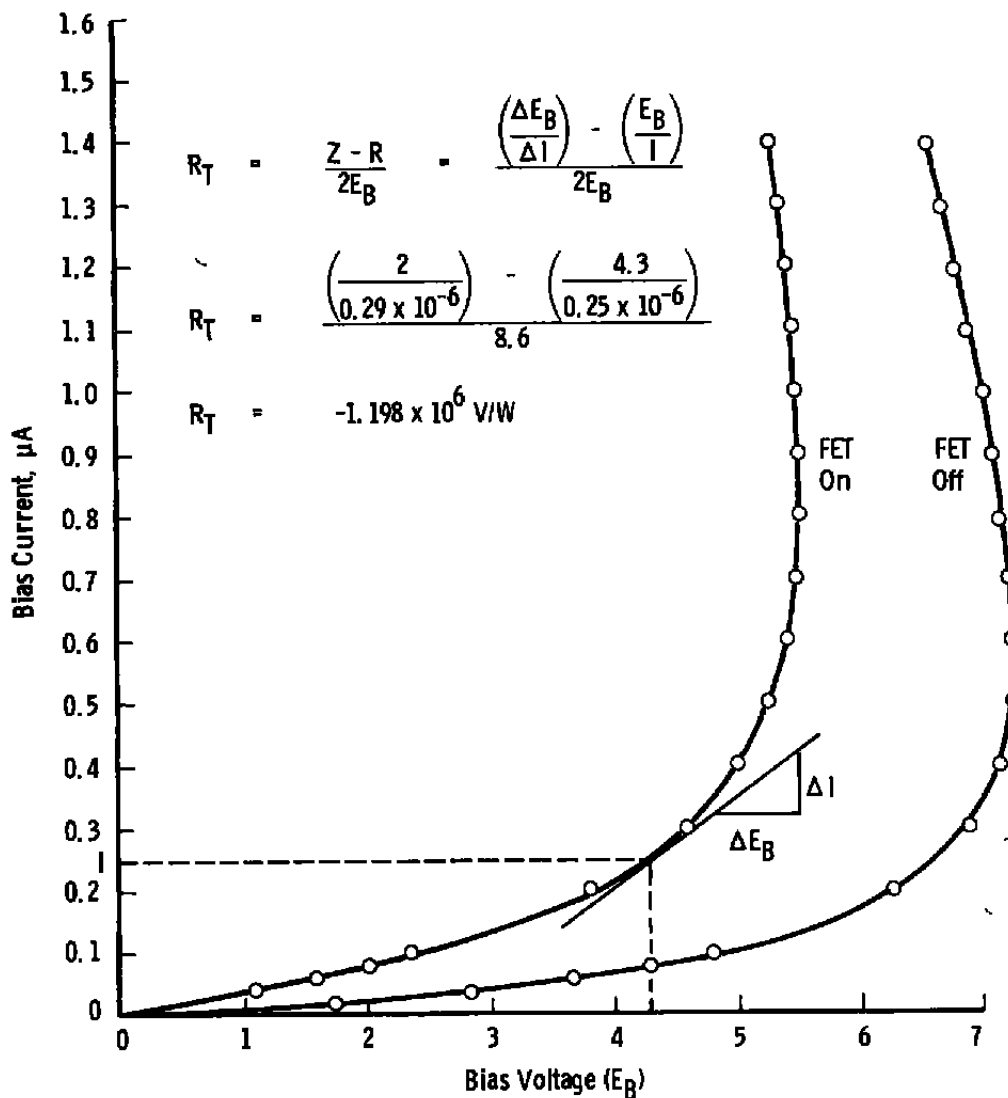

Figure 6. Experimental load curve.

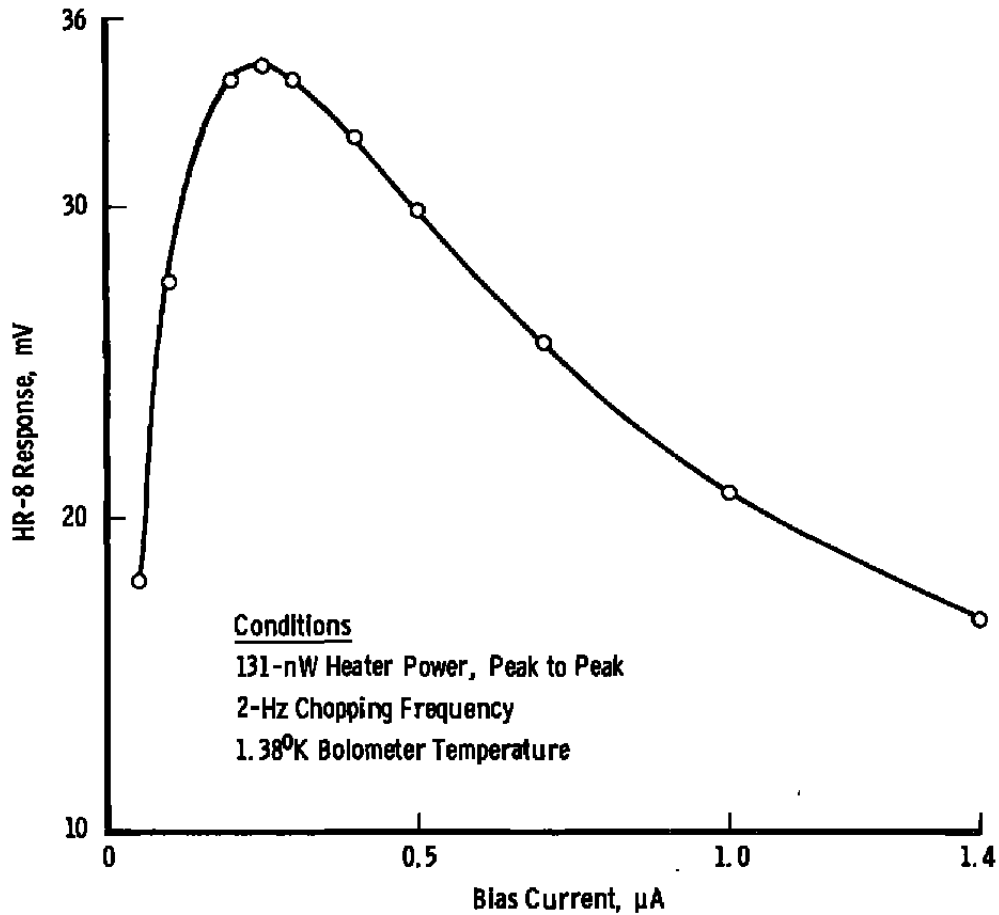

Figure 7. Bolometer response as a function of bias current.

3.2 RESPONSIVITY TO HEATER POWER

Bolometer system responsivity to injected heater power is calculated from the expression

$$R_T = \frac{2.22 E_{BH}}{\frac{[(0.913) (2.22 E_S)]^2}{R_h}} \quad (5)$$

where

- R_H = bolometer responsivity to heat power in volts peak-to-peak per watt peak-to-peak
- R_h = heater resistance (782 Ω)

- E_{BH} = PAR Model HR-8 reading of bolometer output signal (volts rms of fundamental component) at the output of Op-Amp 2, Fig. 4
 E_S = PAR Model HR-8 calibrate output voltage applied to bolometer thin-film heater
 0.913 factor = correction for lead resistance of heater and source resistance of HR-8 calibrate output
 2.22 factor = conversion of voltage from rms of the fundamental component to peak-to-peak of the square wave shape of the bolometer signal

Linearity of the bolometer response to heater input power is demonstrated by the experimental data in Fig. 8. To obtain these data the heater voltage was obtained from the Model HR-8 calibrate source and the bolometer output response was read on the HR-8 lock-in amplifier. Therefore, the ordinate of Fig. 8 is the bolometer output voltage (rms of fundamental) read at the output of Op-Amp 2. The abscissa of Fig. 8 is the input power to the bolometer heater in units of watts peak-to-peak as defined by the denominator of Eq. (5). Figure 8 shows that the bolometer and the associated preamp are linear.

3.3 RESPONSIVITY TO RADIOMETRIC POWER

The power absorbed by the bolometer when it is exposed to the output aperture of the UA blackbody is given by

$$P = \frac{\alpha \epsilon \sigma A_S T^4}{\pi} \frac{dA_B}{r^2} \quad (6)$$

where

- P = absorbed power in watts steady state, or watts peak-to-peak when the blackbody is chopped
 α = absorptivity of the painted bolometer surface (0.94)
 ϵ = emissivity of the source (assumed to be unity)
 σ = Stefan-Boltzmann constant (5.67×10^{-12} W/cm² K⁴)
 A_S = area of the source aperture (4.28×10^{-3} cm²)
 T = temperature of the UA blackbody in degrees Kelvin (°K)
 dA_B = area of the absorbing surface of the bolometer (0.252 cm²)
 r = distance from the source aperture to the bolometer chip (28 cm)

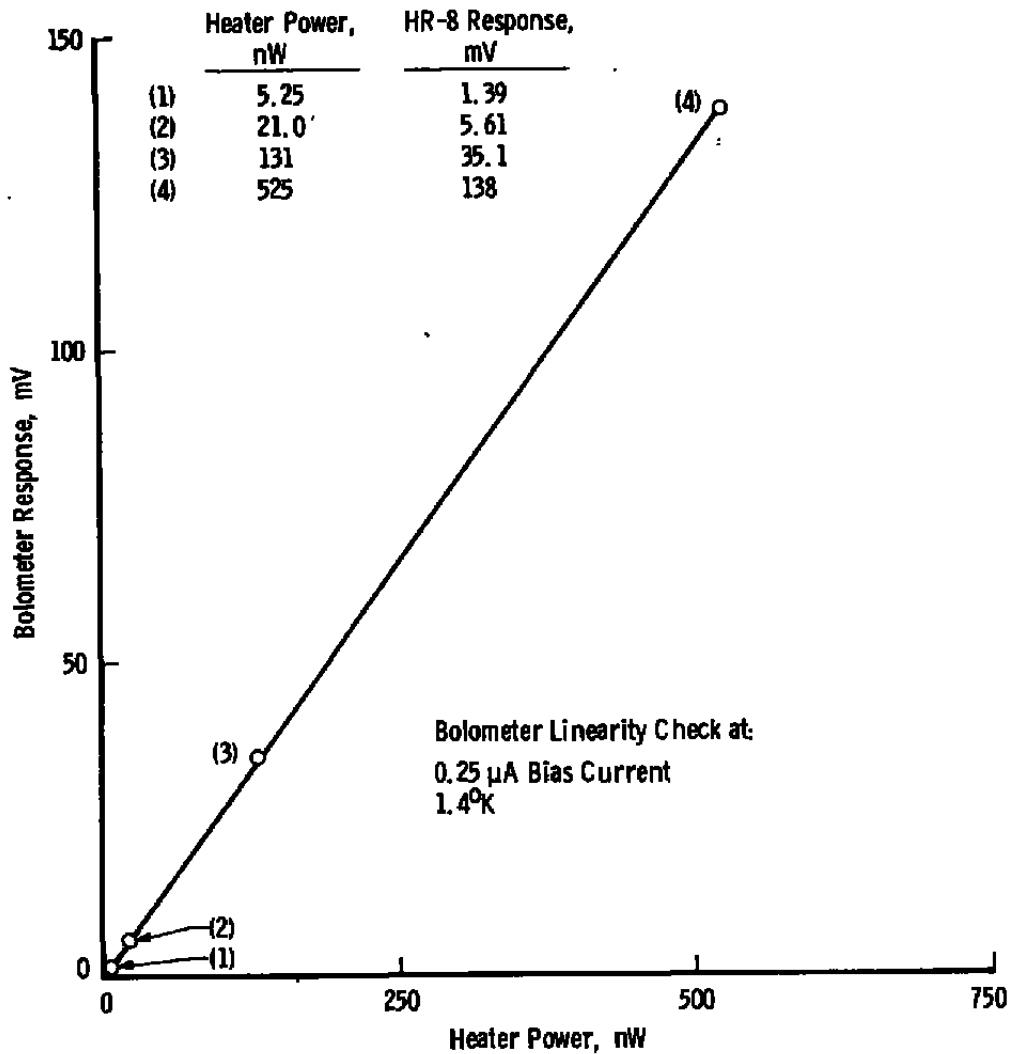

Figure 8. Bolometer response to heater input power.

Substituting the constants into Eq. (6) gives the power absorbed by the bolometer as a function of temperature, T:

$$P = 2.33 \times 10^{-18} T^4 \text{ watts} \tag{7}$$

The bolometer system responsivity to blackbody power becomes

$$R_B = \frac{2.22 E_{BS}}{2.22 \times 10^{-18} T^4} \tag{8}$$

where

- R_B = responsivity in volts peak-to-peak per watt peak-to-peak
 E_{BS} = PAR Model HR-8 reading of bolometer output signal (output of Op-Amp 2, Fig. 4)
 T = blackbody temperature

Since the blackbody radiometric temperature, T_R , and the PRT indicated blackbody temperature, T_I , are not the same [see Eq. (3)], the bolometer responsivity to blackbody power, Eq. (8), will be calculated for both T_R and T_I at each blackbody temperature setting (see Section 4.0).

4.0 CALIBRATION DATA

Tables 1, 2, and 3 present a complete summary of the experimental data from three separate runs over a three-week period. PRT 1 in the UA blackbody was used to determine the blackbody core temperature. The current source and shunt resistor used to measure PRT resistance were calibrated in the following manner. A correction factor was determined by simulating the PRT with a precision decade box. A resistance of 99.96 Ω yielded an indicated resistance of 100.5 Ω . Therefore, each indicated PRT resistance multiplied by 0.9946 produces the correct PRT resistance. These data are listed in the "PRT 1 Reading" rows of Tables 1, 2, and 3.

The corrected resistance was used to determine both indicated blackbody temperature, T_I , according to the Rosemount calibration and subsequently, the NBS radiometric temperature, T_R , from Eq. (3). These temperatures are shown in the "Corrected Blackbody Temperature" row of Tables 1, 2, and 3. At each blackbody temperature setting, the bolometer output signal was measured and the responsivity, R_B , to blackbody power was calculated from Eq. (8) for both T_I and T_R . The units of R_B are kilovolts peak-to-peak per watt peak-to-peak. These data are presented in the "Bolometer Output (Radiometric)" row and the "Radiometric Responsivity" row of Tables 1, 2, and 3.

To compare bolometer radiometric responsivity to heater power responsivity, one should adjust the input heater voltage, E_S , to a level that produces a bolometer output, E_{BH} , equal to the radiometric bolometer output, E_{BS} , at each blackbody temperature. However, the calibrate output of the HR-8 is adjustable only in a 1-2-5 sequence. Therefore, an extrapolated value of E_S was determined in the following manner. The bolometer output signal (E_{BH}) was measured at heater power levels just above and just below the radiometric power level of each blackbody temperature setting. (See the rows labeled "Bolometer

Output/Input (Heater)" in Tables 1, 2 and 3.). The bolometer system response to heater power is linear (see Fig. 8) and, therefore, proportional to the square of the heater voltage:

$$E_{BH} = a + bE_S^2 \quad (9)$$

The applied heater voltage (E_S) and measured bolometer output signal (E_{BH}) for the points above and below each radiometric power level were used to calculate coefficients a and b from a pair of simultaneous equations of the form of Eq. (9). With these values of a and b , Eq. (9) was then solved for the specific heater voltage, which would produce a bolometer signal equal to the observed radiometric bolometer signal at each blackbody temperature setting. This interpolated value of E_S was then used in applying Eq. (5) to calculate the bolometer responsivity, R_H , to heater power in units of kilovolts peak-to-peak per watt peak-to-peak. These data are in the row labeled "Responsivity to Heater Power" in Tables 1, 2, and 3.

The ratios of responsivity to heater power and responsivity to radiometric power were then calculated at each blackbody temperature setting. These ratios, R_H/R_B , are presented in the bottom rows of Tables 1, 2, and 3.

An additional data run (see Table 4) was made at a blackbody temperature setting of 298°K to determine whether the ratio R_H/R_B varies with bolometer temperature. This is of interest because the helium dewar (i.e., bolometer) temperature is not precisely regulated and rises slightly over a period of hours following a helium charge. As indicated in the top row of Table 4, the bolometer temperature was varied from 1.42 to 1.75°K. This variation was accomplished by throttling the pump connected to the helium dewar. The bolometer responsivities to heater and radiometric power are shown in Table 4 for each dewar temperature. The data in Table 4 were reduced in the same way as the data in the previous three tables. As usual, the radiometric responsivities were calculated from Eq. (8) using both the Rosemount PRT indicated temperature, T_I , and the corresponding NBS radiometric temperature, T_R . These calculated radiometric responsivities are nearly equal, because T_I and T_R are nearly equal around 298°K.

The data in Table 4 show that while the radiometric bolometer responsivity varies strongly with dewar temperature, the ratio R_H/R_B is essentially constant from 1.42°K to 1.75°K. These results suggest that in future applications of the bolometer to calibrate unknown infrared sources, precise regulation of the dewar temperature may not be required. Instead it may be adequate to determine R_H (a simple procedure) and divide R_H by the predetermined R_H/R_B factor (i.e., 0.8) to get a short-term value for R_B . Further experimental work will be required to establish the uncertainties of this calibration procedure.

Table 1. Run 1 Data

PRT 1 Reading	Indicated	Ω	101.2	110.4	120.0	127.5	145.5					
	Corrected	Ω	100.66	109.81	119.36	126.52	144.72					
Corrected Blackbody Temp.	Rosemount Temp. (T_I)	$^{\circ}\text{K}$	274.47	297.69	322.08	340.48	387.67					
	NBS Radiometric Temp. (T_R)	$^{\circ}\text{K}$	271.55	297.37	324.44	344.91	397.29					
Bolometer Temp.	Indicated He Vapor Pressure	mm	2.82	2.85	2.99	3.06	3.1					
	Corresponding He Temp.	$^{\circ}\text{K}$	1.42	1.42	1.43	1.44	1.44					
Bolometer Output (E_{BS}) (Radiometric)	HR-8 Reading	mV	3.98	5.58	7.54	9.4	15.2					
	Tare	μV	-80	-100	-100	-100	-100					
Bolometer Output/Input (Heater)	HR-8 Reading (E_{BH})	mV	1.18	4.9	5.15	32.5	5.05	31.7	4.9	31.2	4.75	30.4
	Heater Input (E_S)	mV	1	2	2	5	2	5	2	5	2	5
Interpolated Heater Input Voltage for Equal Bolometer Signals		mV	1.805	2.08	2.44	2.756	3.54					
Radiometric Responsivity (R_B)	NBS Temp.	KV/W	711.0	691.7	656.6	639.3	584.8					
	Rosemount Temp.	KV/W	681.35	688.7	676.1	673.2	645.0					
Responsivity to Heater Power	Interpolated Heater Power	nW	17.12	22.73	31.28	39.9	65.83					
	Bolometer Responsivity (R_H)	KV/W	526.7	554.9	542.4	528.7	514.9					
$\frac{R_H}{R_B} \times 100$ percent	NBS Temp.	percent	74.1	80.2	82.6	82.7	88.0					
	Rosemount Temp.	percent	77.3	80.6	80.2	78.5	79.8					

Notes: (1) Data taken May 18 with 17.2^oK background and a chopping frequency of 2 Hz.

(2) All bolometer output and input readings from the HR-8 reported above are in terms of rms voltage of the fundamental component.

Table 2. Run 2 Data

PRT 1 Reading	Indicated	Ω	101.35		110.65		120.2		127.5		145.75	
	Corrected	Ω	100.8		110.06		119.55		126.32		144.97	
Corrected Blackbody Temp.	Rosemount Temp. (T_r)	$^{\circ}\text{K}$	274.83		298.33		322.57		339.96		388.32	
	NBS Radiometric Temp. (T_r)	$^{\circ}\text{K}$	271.94		298.07		324.99		344.3		398.0	
Bolometer Temp.	Indicated He Vapor Pressure	mm	2.85		2.92		3.08		3.09		3.12	
	Corresponding He Temp.	$^{\circ}\text{K}$	1.42		1.43		1.44		1.44		1.44	
Bolometer Output (E_{BS}) (Radiometric)	HR-8 Reading	mV	3.88		5.28		7.2		9.18		15.6	
	Tare	μV	-80		-80		-80		-80		-80	
Bolometer Output/Input (Heater)	HR-8 Reading (E_{BH})	mV	1.21	31.9	5.01	31.6	4.82	30.9	4.8	31.0	4.81	31.1
	Heater Input (E_H)	mV	1	5	2	5	2	5	2	5	2	5
Interpolated Heater Input Voltage for Equal Bolometer Signals		mV	1.757		2.053		2.432		2.74		3.55	
Radiometric Responsivity (R_B)	NBS Temp.	KV/W	689.6		646.7		621.4		627.5		595.0	
	Rosemount Temp.	KV/W	661.1		644.4		640.3		660.2		656.7	
Responsivity to Heater Power	Interpolated Heater Power	nW	16.22		22.14		31.07		39.44		66.21	
	Bolometer Responsivity (R_H)	KV/W	541.9		537.6		520.1		521.1		525.2	
$\frac{R_H}{R_B} \times 100$ percent	NBS Temp.	percent	78.6		83.1		83.7		83		88.3	
	Rosemount Temp.	percent	82		83.4		81.3		78.9		80	

Notes: (1) Data taken May 19, 1978 with 17.3 $^{\circ}\text{K}$ background and chopping frequency of 2 Hz.

(2) All bolometer output and input readings from the HR-8 reported above are in terms of rms voltage of the fundamental component.

Table 3. Run 3 Data

PRT 1 Reading	Indicated	Ω	100.5	110.45	120.05	127.4	145.8					
	Corrected	Ω	100.06	109.97	119.40	126.72	145.02					
Corrected Blackbody Temp.	Rosemount Temp. (T_I)	$^{\circ}\text{K}$	272.95	298.1	322.18	340.99	388.46					
	NBS Radiometric Temp. (T_R)	$^{\circ}\text{K}$	269.87	297.82	324.52	345.42	398.16					
Bolometer Temp.	Indicated He Vapor Pressure	mm	2.86	2.98	3.06	3.09	3.11					
	Corresponding He Temp.	$^{\circ}\text{K}$	1.42	1.43	1.44	1.44	1.44					
Bolometer Output (E_B) (Radiometric)	HR-8 Reading	mV	4.4	6.21	8.43	10.5	17.4					
	Tare	μV	-80	-80	-80	-80	-80					
Bolometer Output/Input (Heater)	HR-8 Reading (E_{BH})	mV	1.35	5.78	5.63	35.6	5.6	35.5	5.59	35.3	5.41	34.8
	Heater Input (E_g)	mV	1	2	2	5	2	5	2	5	2	5
Interpolated Heater Input Voltage for Equal Bolometer Signals		mV	1.765		2.099		2.447		2.733		3.544	
Radiometric Responsivity (R_B)	NBS Temp.	KV/W	804.7	761.8	731.1	708.1	662.7					
	Rosemount Temp.	KV/W	769.1	758.9	752.7	745.6	731.4					
Responsivity to Heater Power	Interpolated Heater Power	nW	16.4	23.1	31.4	39.2	66					
	Bolometer Responsivity (R_H)	KV/W	607.8	603.4	600.8	598.7	588					
$\frac{R_H}{R_B} \times 100$ percent	NBS Temp.	percent	75.6	79.2	82.2	84.6	88.7					
	Rosemount Temp.	percent	79	79.5	79.8	80.3	80.4					

Notes: (1) Data taken June 2, 1978 with 16.9 $^{\circ}\text{K}$ background and a chopping frequency of 2.8 Hz.

(2) All bolometer output and input readings from the HR-8 reported above are in terms of rms voltage of the fundamental component.

Table 4. Responsivity Variation with Bolometer Temperature

Helium Dewar Temperature		°K	1.42	1.44	1.47	1.51	1.58	1.63	1.7	1.75
Bolometer Output Signal		mV	6.0	5.8	5.62	5.38	4.7	4.41	3.95	3.50
Bolometer Signal Tare Reading		μV	-50	-50	-50	-50	-80	-80	-80	-80
Interpolated Heater Voltage for Equal Signals		mV	2.106	2.106	2.098	2.095	2.101	2.100	2.100	2.092
Bolometer Responsivity to Heater Power (R_H)		KV/W	576.6	557.6	544.7	522.7	457.7	430.6	386.4	345.8
Radiometric Responsivity (R_B)	NBS Temp.	KV/W	726.2	702.15	680.53	651.7	573.7	538.8	483.6	429.6
	Rosemount Temp.	KV/W	728.8	704.7	683	654.1	575.8	540.8	485.4	431.2
$\frac{R_H}{R_B} \times$ 100 percent	NBS Temp.	percent	79.4	79.41	80.02	80.02	79.78	79.92	79.89	80.5
	Rosemount Temp.	%	79.1	79.1	79.9	79.9	79.5	79.6	79.6	80.2

June 1, 1978 -- Responsivity versus He Dewar Temperature at 297.9°K Blackbody Temperature

$$\begin{aligned} \text{Calculated BB Power} &= 1.842 \times 10^{-8} \text{ W (Rosemount)} \\ &= 1.836 \times 10^{-8} \text{ W (NBS)} \end{aligned}$$

5.0 DISCUSSION OF RESULTS

The data in the "Corrected Blackbody Temperature" rows of Tables 1, 2, and 3 show that T_I and T_R are the same near 298°K, but they are 10°K apart near 400°K. These data follow directly from the NBS calibration of the UA blackbody as presented in Eq. (3). The fact that T_I and T_R are not the same generates a dilemma with the experimental results. Specifically, Fig. 8 shows that the Molecron bolometer response to heater power is extremely linear. It seems reasonable, therefore, to expect the bolometer to respond linearly with radiometric power. Equation (7) is the expression for absorbed radiometric power. The absorbed power was calculated from Eq. (7) for both T_I and T_R at each setting of the UA blackbody temperature. The resulting pair of values was plotted versus the bolometer output signal at each temperature setting. As shown in Table 1, data were taken at five different temperature settings. These plots of bolometer output signal versus absorbed radiometric power are shown in Fig. 9. Figures 10 and 11 are corresponding plots of the data from Tables 2 and 3, respectively.

The bolometer readings plotted in Figs. 9, 10, and 11 are the E_{BS} values from the tables, after subtracting the (negative) tare readings and correcting slightly to compensate for the bolometer responsivity change due to bolometer temperature changes. The magnitude of the corrections (not shown in the tables) was determined from the magnitude of the change in the R_H values as listed in the tables. The data points plotted in Figs. 9, 10, and 11 were standardized to the bolometer signal level when the 298°K data points were taken. These corrections in bolometer output signal levels were necessary because in the hour or more required to readjust the UA blackbody temperature the helium dewar temperature and bolometer responsivity changed slightly. The corrections always amounted to considerably less than 10 percent of signal level.

From all foregoing discussions, the plots in Figs. 9, 10, and 11 should show linear relationships between bolometer signal and absorbed power only when the blackbody temperatures are assumed to be T_R . Instead, the plots are linear when the blackbody temperature is taken to be T_I , which is the Rosemount PRT indication of core temperature.

Resolution of this dilemma will require additional calibration exercises. One possible explanation is that the UA blackbody is not a Lambertian radiator. It may emit excess radiation off axis. Such excess radiation may be detected by the NBS bolometer and not detected by the Molecron bolometer. This possible explanation is derived from the fact that the collection solid angle of the NBS bolometer is much larger than that of the Molecron bolometer.

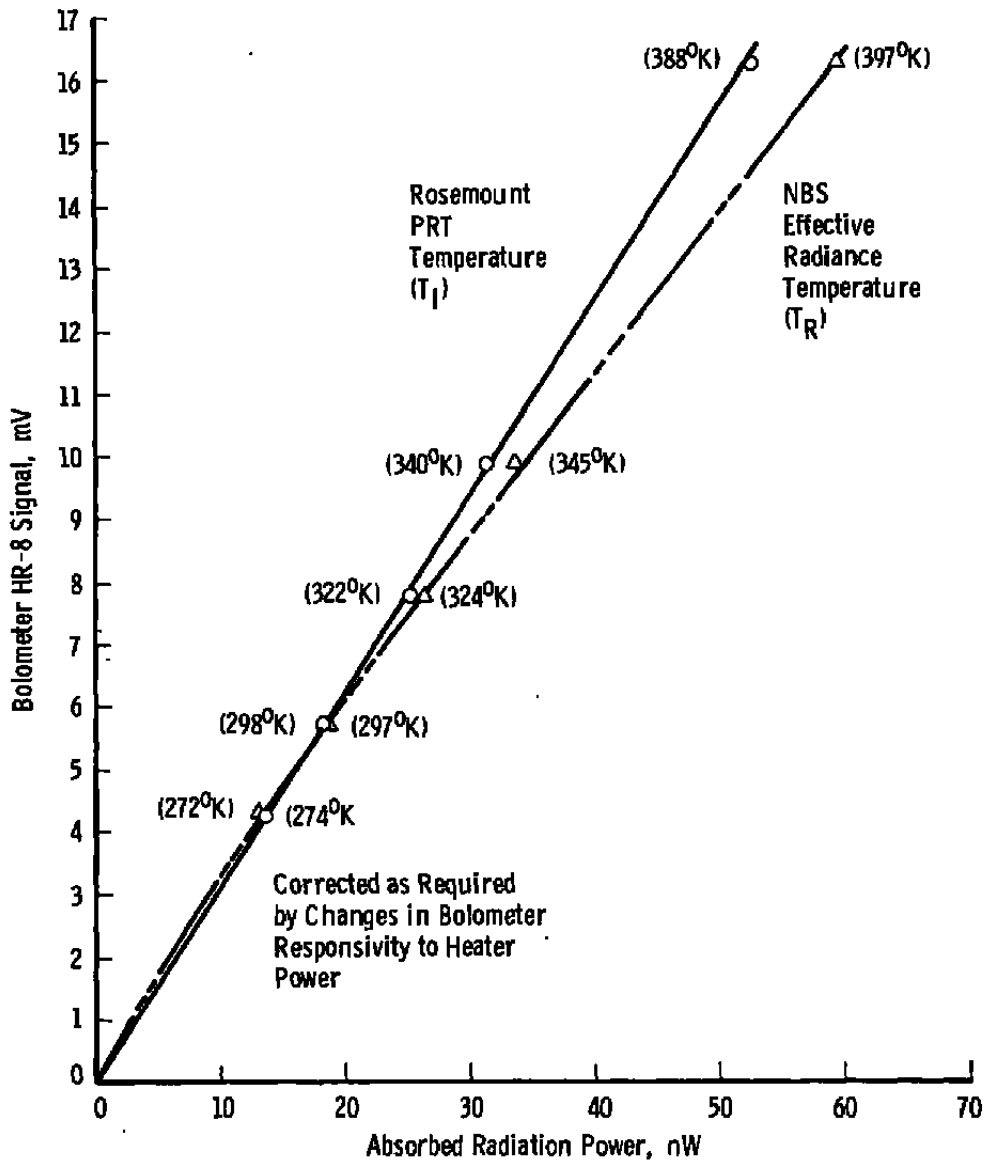

Figure 9. Bolometer response to radiometric power, run 1.

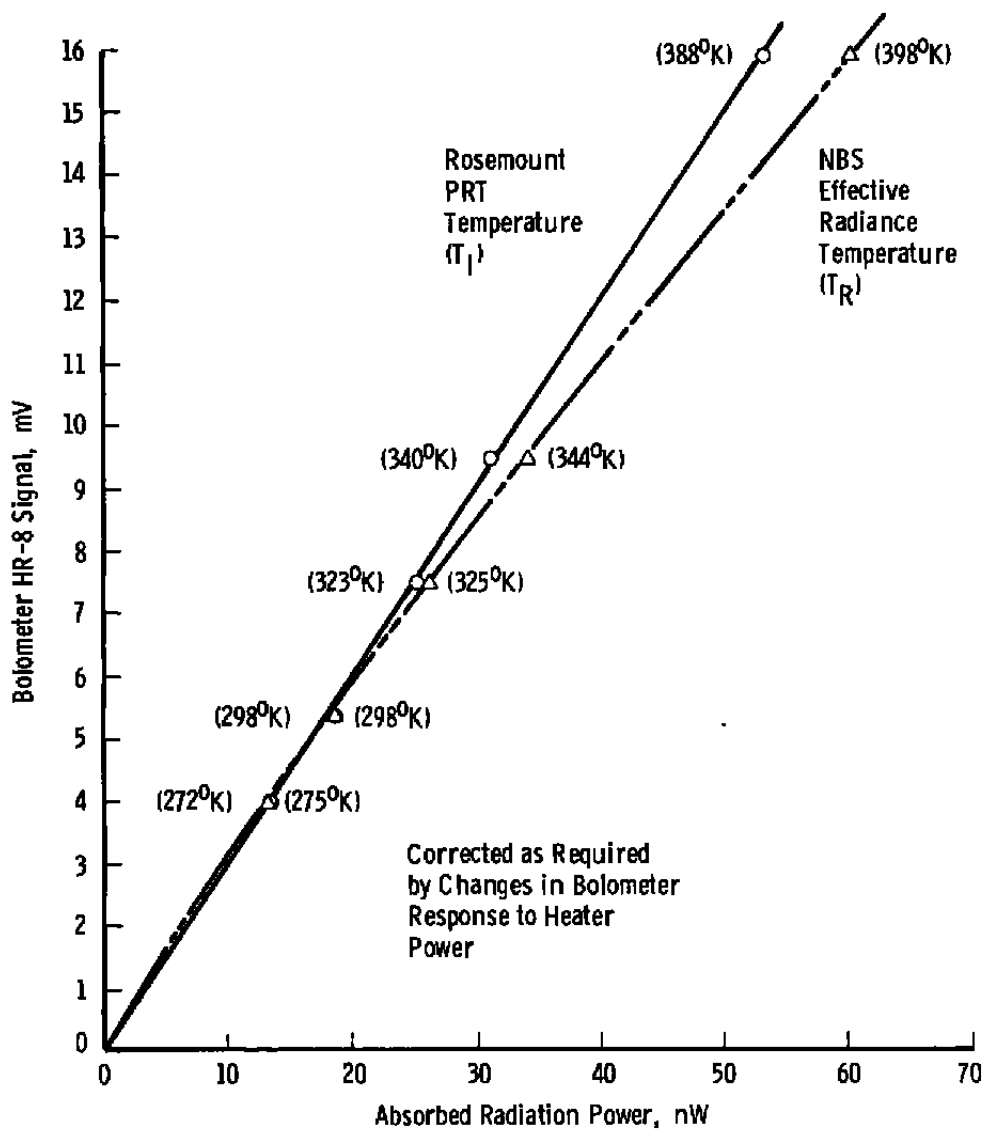

Figure 10. Bolometer response to radiometric power, run 2.

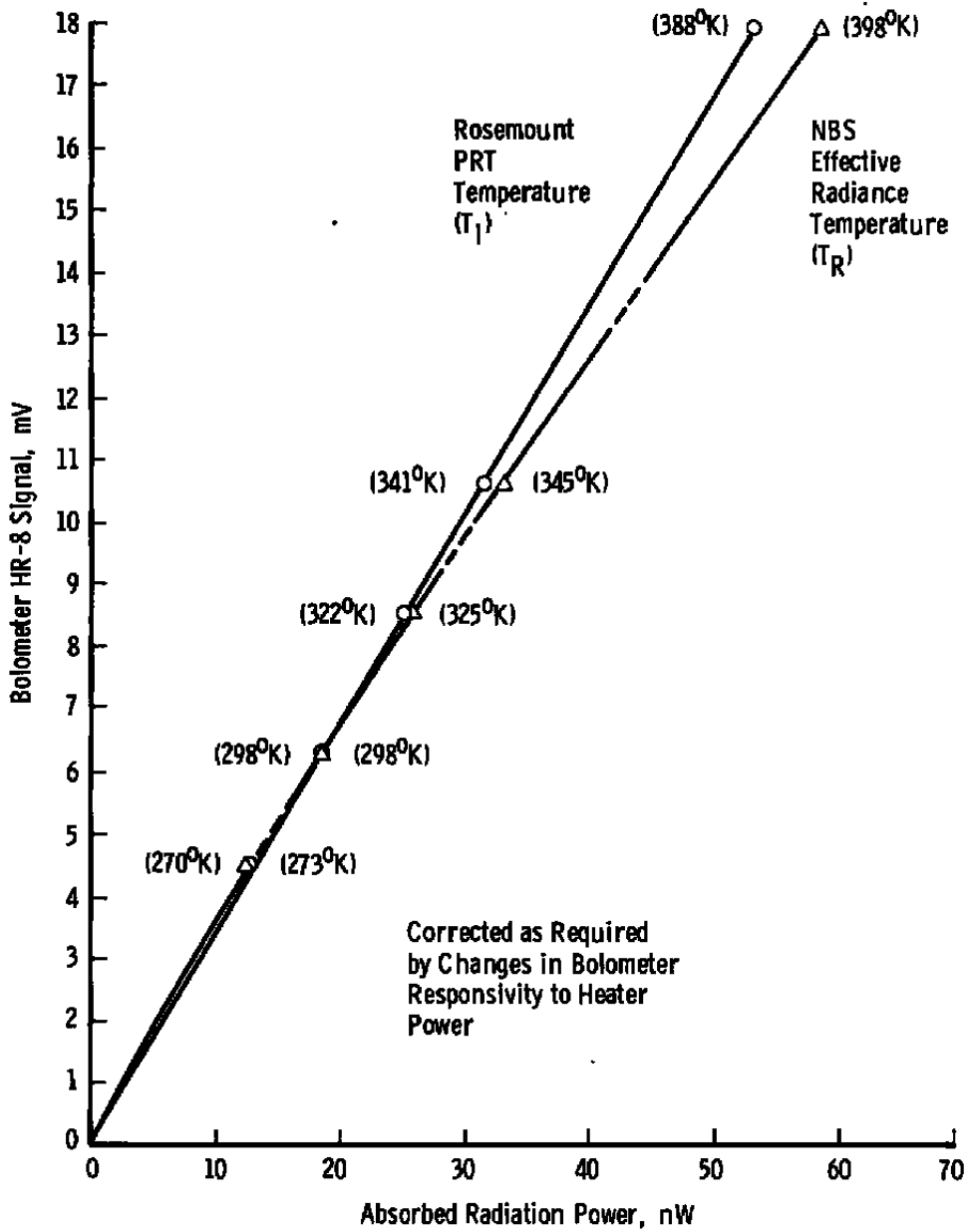

Figure 11. Bolometer response to radiometric power, run 3.

Since there is no difference between T_I and T_R near 298°K, the bolometer calibration data taken at this UA blackbody temperature should be correct. Reviewing these data indicates that R_B , the bolometer responsivity to radiometric power, is 700 ± 60 kv/w. The responsivity to heater power is considerably lower and, from the tables, is around 560 kv/w. Recall that in Section 3.1 the theoretical bolometer responsivity was calculated to be 1,010 kv/w. These values are tentative and subject to verification in future, planned bolometer calibrations. From the results obtained in this project it appears that R_H and R_B are not as nearly equal as anticipated during the original bolometer development.

6.0 CONCLUSIONS

Anomalous experimental results were obtained in the form of a nonlinear Molelectron bolometer response when the bolometer was calibrated against the University of Arizona blackbody. Since bolometer linearity was demonstrated using its integral thin-film heater, the bolometer calibration results must be considered to be ambiguous. It is not possible to identify the source of the problem conclusively from the experimental results obtained to date. It is recommended that the work reported herein be repeated with an NBS-calibrated infrared source other than the UA blackbody. This new source should be designed with particular attention to eliminating stray radiation and producing an equality between indicated and effective core temperatures.

REFERENCES

1. Kunz, L. W. "An Improved Silicon Bolometer with Self-Calibrating Capability." *Proceedings of the Society of Photo-Optical Instrumentation Engineers*, Vol. 67, 1975, pp. 37-40.
2. Sherrell, F. G. "Applications of a Self-Calibrating Silicon Bolometer." AEDC-TR-76-145 (ADB014347L), October 1976.
3. Wolfe, W. L. and Bartell, F. O. "Improved Blackbody Simulator." SAMSO-TR-74-206, June 1974.
4. Jones, R. C. "The General Theory of Bolometer Performance." *Journal of the Optical Society of America*, Vol. 43, No. 1, January 1953, pp. 1-14.

NOMENCLATURE

A_s	Area of UA blackbody
dA_B	Area of bolometer absorbing surface
E_A	Bolometer bias voltage applied to bolometer and 3 M Ω of series resistance
E_B	Bolometer element bias voltage
E_{BH}	Bolometer output signal when bolometer is heated electrically
E_{BS}	Bolometer output signal when bolometer is heated radiometrically
E_S	Voltage applied to bolometer heater
I	Bolometer bias current
$K\Omega$	10 ³ Ω
$M\Omega$	10 ⁶ Ω
P	Absorbed radiometric power
R	Bolometer resistance at the operating bias current level
R_B	Bolometer responsivity to absorbed radiometric power
R_H	Bolometer responsivity to injected heater power
R_h	Resistance of bolometer heater
R_T	Theoretical bolometer responsivity
r	Distance from University of Arizona blackbody aperture to bolometer surface
T	Temperature of UA blackbody
T_i	Indicated source temperature from Rosemount data

T_R	Effective radiometric temperature from NBS data
UA	University of Arizona
V_T	Test voltage applied in series with the bolometer element
Z	Dynamic bolometer resistance at the operating bias current level
α	Bolometer surface absorptivity
ϵ	Emissivity of UA blackbody
σ	Stefan-Boltzmann constant