

AD-A068 236

MASSACHUSETTS INST OF TECH CAMBRIDGE ELECTRONIC SYST--ETC F/G 9/4
DETERMINISTIC FEEDBACK CODING SCHEMES FOR THE ADDITIVE WHITE GA--ETC(U)
JAN 79 L H OZAROW, S K LEUNG-YAN-CHEONG N00014-75-C-1183

UNCLASSIFIED

ESL-P-760

NL

| OF |
AD
A068236



END
DATE
FILMED
6-79
DOC

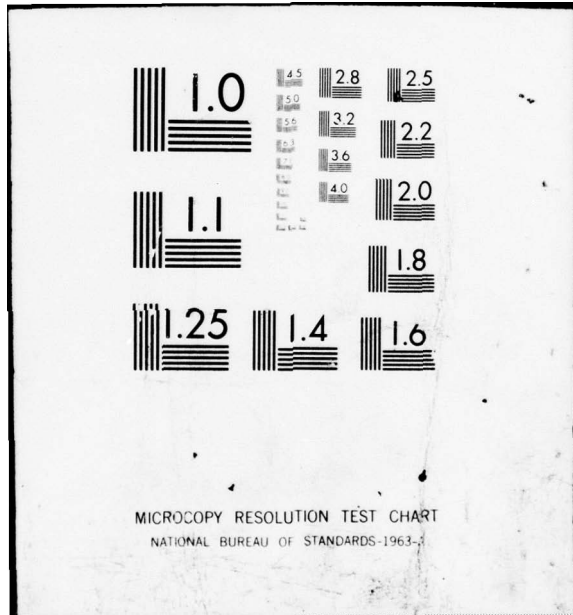

MICROCOPY RESOLUTION TEST CHART
NATIONAL BUREAU OF STANDARDS-1963-A

REPORT DOCUMENTATION PAGE

READ INSTRUCTIONS
BEFORE COMPLETING FORM

1. REPORT NUMBER	2. GOVT ACCESSION NO.	3. RECIPIENT'S CATALOG NUMBER
4. TITLE (and Subtitle) Deterministic Feedback Coding Schemes for the Additive White Gaussian Noise Broadcast and Multiple-Access Channels		5. TYPE OF REPORT PERIOD COVERED Paper
7. AUTHOR(s) Lawrence H./Ozarow S.K./Leung-Yan-Cheong		6. PERFORMING ORG. REPORT NUMBER ESL-P-760
9. PERFORMING ORGANIZATION NAME AND ADDRESS M.I.T. Laboratory for Information and Decision Systems Cambridge, MA 02139		8. CONTRACT OR GRANT NUMBER(s) ONR/N00014-75-C-1183
11. CONTROLLING OFFICE NAME AND ADDRESS Advanced Research Projects Agency 1400 Wilson Boulevard Arlington, Virginia 22209		10. PROGRAM ELEMENT, PROJECT, TASK AREA & WORK UNIT NUMBERS Program Code No. 5T10 ONR Identifying No. 049-383
14. MONITORING AGENCY NAME & ADDRESS (if different from Controlling Office) Office of Naval Research Information Systems Program Code 437 Arlington, Virginia 22217		12. REPORT DATE Jan 1979
		13. NUMBER OF PAGES 31p.
16. DISTRIBUTION STATEMENT (of this Report) Approved for public release; distribution unlimited		15. SECURITY CLASS. (of this report) Unclassified
17. DISTRIBUTION STATEMENT (of the abstract entered in Block 20, if different from Report)		15a. DECLASSIFICATION/SCHEDULE LEVEL
18. SUPPLEMENTARY NOTES		
19. KEY WORDS (Continue on reverse side if necessary and identify by block number)		
20. ABSTRACT (Continue on reverse side if necessary and identify by block number) Models of the additive white Gaussian noise (AWGN) broadcast channel with feedback are analyzed. A deterministic coding procedure is proposed which allows reliable transmission at all rate points inside the capacity regions of these models. A deterministic coding scheme for the AWGN multiple-access channel with feedback is also evaluated. This scheme achieves rate points beyond those found by Cover and Leung.		

AD A 068236

DDC FILE COPY

DDC
APPROVED
MAR 16 1979
RECEIVED
A

479 03 15 015

127 200

Deterministic Feedback Coding Schemes For The
Additive White Gaussian Noise Broadcast
and Multiple-Access Channels

Lawrence H. Ozarow

S. K. Leung-Yan-Cheong

ACCESSION (or)	
RTIS	White Section <input checked="" type="checkbox"/>
DDC	Soft Section <input type="checkbox"/>
UNANNOUNCED	<input type="checkbox"/>
JUSTIFICATION	
BY	
DISTRIBUTION/AVAILABILITY CODES	
Dist.	AVAIL. CODE BY SPECIAL
A	

ABSTRACT

Models of the additive white Gaussian noise (AWGN) broadcast channel with feedback are analyzed. A deterministic coding procedure is proposed which allows reliable transmission at all rate points inside the capacity regions of these models. A deterministic coding scheme for the AWGN multiple-access channel with feedback is also evaluated. This scheme achieves rate points beyond those found by Cover and Leung.

This research was conducted at the M.I.T. Laboratory for Information and Decision Systems, with support from ARPA under Grant ONR/N00014-75-C-1183, and M.I.T. Lincoln Laboratory.

B
79 03 15 015

1. Introduction

Much of the recent research efforts in Information Theory have been devoted to the study of multi-user channels. Interest in this area derived from an early paper of Shannon [1]. Most of the work done since then can be found in a recent survey paper by Van der Meulen [2]. The vast majority of results are in the form of coding and capacity theorems, the former being proved by the use of random coding arguments.

Two multi-user channels which have received considerable attention are the broadcast channel [3] and the multiple-access channel [4,5,6]. The broadcast channel models the problem in which one transmitter is interested in communicating with several receivers. The dual problem in which several transmitters wish to communicate with one receiver is modelled by the multiple-access channel.

In this paper, we will develop deterministic feedback coding schemes for the additive white Gaussian noise (AWGN) broadcast channel and multiple-access channel. For a model of the AWGN broadcast channel with feedback, the proposed scheme achieves all points in the capacity region. A proposed scheme for the AWGN multiple-access channel with feedback is shown to achieve rate points beyond those found by Cover and Leung [7].

The broadcast channel is considered in Section 2. Section 3 analyzes the multiple-access channel. A discussion of the results is given in the last section.

2. The AWGN Broadcast Channel

In his innovative paper on broadcast channels [3], Cover analyzed the additive white Gaussian noise (AWGN) broadcast channel in which one transmitter with an average power constraint P wishes to communicate with two or more receivers. For simplicity, we confine the discussion to the two-receiver case. Suppose that the channel bandwidth is W and the noises to the first and second receivers have (two-sided) power spectral densities $N_1/2$ and $(N_1+N_2)/2$ respectively. Under this condition, Cover [3] and Bergmans [8] showed, by random coding arguments, that all rate pairs (R_1, R_2) such that

$$R_1 \leq W \ln \left(1 + \frac{\alpha P}{N_1 W} \right) \triangleq C_1(\alpha)$$

$$R_2 \leq W \ln \left(1 + \frac{\bar{\alpha} P}{\alpha P + (N_1 + N_2) W} \right) \triangleq C_2(\alpha), \quad \alpha \in [0, 1], \quad \bar{\alpha} = 1 - \alpha \quad (1)$$

are achievable, i.e. reliable communication from the transmitter to receivers 1 and 2 is simultaneously possible at rates R_1 and R_2 respectively. The rate region defined by (1) was later shown to be the capacity region by Bergmans [9].

In this paper we consider a model of the AWGN broadcast channel with feedback depicted in Figure 1 and propose a deterministic coding scheme which achieves the region defined by (1).

In section 2.1 we first consider a model of the AWGN broadcast channel with feedback depicted in Figure 1 and propose a deterministic coding scheme which achieves the region defined by (1). Section 2.2 examines a model in which the noises on the forward channels are independent. The schemes employed are reminiscent of a procedure used by Schalkwijk and Kailath [10, 11] on additive noise channels with a single receiver. For both models, the feedback schemes achieve all points within the corresponding capacity regions.

2.1 Degraded Broadcast Channel

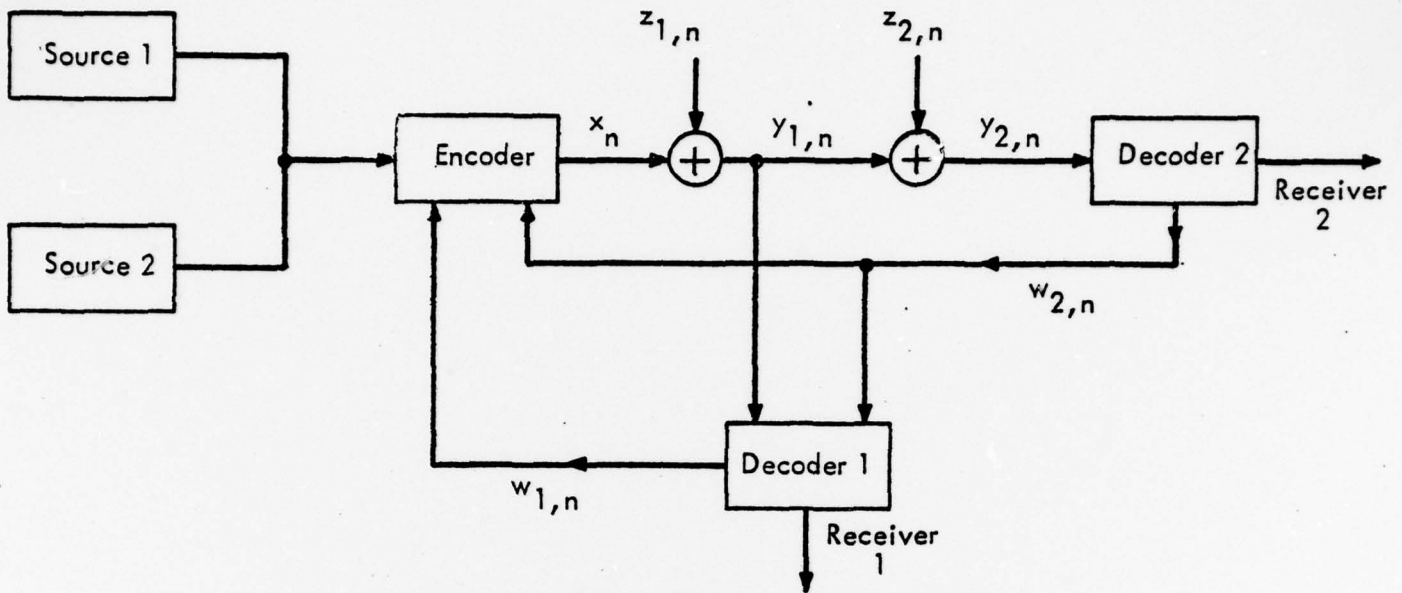

Figure 1. AWGN Broadcast Channel with Feedback

As shown in Figure 1, receiver 2's signal is a noisy version of receiver 1's signal. The first decoder can feed data back noiselessly to the encoder. The data fed back by the second decoder can be viewed by both the encoder and the first decoder. This model would be applicable, for example, in a situation where the first receiver is physically located between the transmitter and the second receiver.

The feedback data may be any function of the received data which allows the transmitter to reconstruct each receiver's current estimate. Two obvious possibilities are for the receivers to send back their current estimates of their received signal. Here, we will assume that the received signals are actually fed back.

For convenience, we summarize here the notation to be used in subsequent sections. The terms will be explained more fully as they appear in the text.

θ_i , $i=1,2$ is the point corresponding to the message to be transmitted by source i .

$Z_{i,n}$, $i=1,2$, $n=-1,0,1,2,3,\dots$ are independent Gaussian noise random variables with means 0 and variances $\sigma_i^2 = N_i/2$.

X_n is the transmitter output at time n . $Y_{1,n}$ and $Y_{2,n}$ are the corresponding outputs at the two receivers. The feedback data at time n are denoted by $W_{1,n}$ and $W_{2,n}$. Of course X_{n+1} is a function of $(\theta_1, \theta_2, W_{1,1}, W_{1,2}, \dots, W_{1,n}, W_{2,1}, W_{2,2}, \dots, W_{2,n})$.

$\hat{\theta}_{1,n}$ and $\hat{\theta}_{2,n}$ are the estimates by decoders 1 and 2 respectively of θ_1 and θ_2 at time n . Of course, in our model $\hat{\theta}_{2,n}$ is also available to the first decoder.

2.1.1 The Coding Scheme

In this sub-section, we will examine a coding scheme which can achieve reliable communication from source i to receiver i at rates defined by (1). We first look at the initialization procedure and then use an induction argument to analyze the proposed scheme. Discussion of the scheme is postponed to a later section.

Suppose that source i wishes to send one of M_i messages to receiver i . Corresponding to source i , we divide the unit interval $[0,1]$ into M_i disjoint message intervals of equal length. Let θ_i be the mid-point of the message interval corresponding to the message to be transmitted to receiver i .

A. Initialization

During the initialization period, the encoder transmits two numbers

$$x_{-1} = (0.5 - \theta_1) \text{ and } x_0 = (0.5 - \theta_2).$$

$$\text{Receiver 1 gets } Y_{1,-1} = (0.5 - \theta_1) + Z_{1,-1} \quad (2)$$

$$Y_{1,0} = (0.5 - \theta_2) + Z_{1,0} \quad (3)$$

$$\text{Receiver 2 gets } Y_{2,-1} = (0.5 - \theta_1) + Z_{1,-1} + Z_{2,-1} \quad (4)$$

$$Y_{2,0} = (0.5 - \theta_2) + Z_{1,0} + Z_{2,0}. \quad (5)$$

The first receiver subtracts (2) from 0.5 to obtain

$$\hat{\theta}_{1,0} = \theta_1 - Z_{1,-1} \quad (6)$$

and also computes (from receiver 2's feedback)

$$\hat{\theta}_{2,0} = \theta_2 - (Z_{1,0} + Z_{2,0}) \quad (7)$$

The second receiver subtracts (5) from 0.5 to obtain

$$\hat{\theta}_{2,0} = \theta_2 - (Z_{1,0} + Z_{2,0}). \quad (8)$$

Note that the second decoder does not attempt to estimate θ_1 . If we define η_k to be receiver 1's error after the k^{th} transmission, and ξ_k to be receiver 2's error, then

$$\eta_0 = -Z_{1,-1} \quad (9)$$

$$\xi_0 = -(Z_{1,0} + Z_{2,0}) \quad (10)$$

and

$$E[\eta_0^2] = \sigma_1^2 \quad (11)$$

$$E[\xi_0^2] = \sigma_1^2 + \sigma_2^2 \quad (12)$$

$$E[\eta_0 \xi_0] = 0 \quad (13)$$

We now proceed to the iterative step.

B. Procedure at time k+1

We assume that after time k, the first receiver has

$$\hat{\theta}_{1,k} = \theta_1 + c_k \theta_2 - d_k + \eta_k \quad (14)$$

and both receivers have

$$\hat{\theta}_{2,k} = \theta_2 + \xi_k \quad (15)$$

where $\frac{\overline{\eta_k^2}}{\alpha_1} = \frac{\sigma_1^2}{2k}$ (16)

$$\frac{\overline{\xi_k^2}}{\alpha_2} = \frac{b_k^2}{2k}, \quad b_k^2 \leq b^2 \triangleq \alpha_1^2 \sigma_1^2 + \sigma_2^2 \quad (17)$$

$$\overline{\eta_k \xi_k} = 0 \quad (18)$$

c_k and d_k are constants, $\alpha_1^2 \triangleq 1+g_1^2$, $\alpha_2^2 \triangleq 1+g_2^2$ and g_1 and g_2 are positive constants to be determined later. At time k+1, the encoder transmits

$$x_{k+1} = g_1 \alpha_1^k \eta_k + g_2 \alpha_2^k \xi_k \quad (19)$$

The encoder determines η_k and ξ_k recursively from η_{k-1} and ξ_{k-1} through equations (27) and (34).

Receiver 1 gets

$$y_{1,k+1} = x_{k+1} + z_{1,k+1} = g_1 \alpha_1^k \eta_k + g_2 \alpha_2^k \xi_k + z_{1,k+1} \quad (20)$$

It also has its previous estimate

$$\hat{\theta}_{1,k} = \theta_1 + c_k \theta_2 - d_k + \eta_k \quad (21)$$

Subtracting $\frac{1}{g_1 \alpha_1^k} y_{1,k+1}$ from (21) yields

$$\theta_1 + c_k \theta_2 - d_k - \frac{g_2 \alpha_2^k}{g_1 \alpha_1^k} \xi_k - \frac{z_{1,k+1}}{g_1 \alpha_1^k} \quad (22)$$

Using (15) in (22) yields

$$\theta_1 + (c_k + \frac{g_2 \alpha_2^k}{g_1 \alpha_1^k}) \theta_2 - (d_k + \frac{g_2 \alpha_2^k}{g_1 \alpha_1^k} \hat{\theta}_{2,k}) - \frac{1}{g_1 \alpha_1^k} z_{1,k+1} \quad (23)$$

Finally we form

$$\begin{aligned} \hat{\theta}_{1,k+1} &= \frac{(21) + g_1^2 (23)}{1 + g_1^2} = \theta_1 + (c_k + \frac{g_1 g_2 \alpha_2^k}{\alpha_1^{k+2}}) \theta_2 - (d_k + \frac{g_1 g_2 \alpha_2^k}{\alpha_1^{k+2}} \hat{\theta}_{2,k}) \\ &+ \frac{1}{\alpha_1^2} \eta_k - \frac{g_1}{\alpha_1^{k+2}} z_{1,k+1} \end{aligned} \quad (24)$$

Comparing (24) with (14) yields

$$c_{k+1} = c_k + \frac{g_1 g_2 \alpha_2^k}{\alpha_1^{k+2}} \quad (25)$$

$$d_{k+1} = d_k + \frac{g_1 g_2 \alpha_2^k}{\alpha_1^{k+2}} \hat{\theta}_{2,k} \quad (26)$$

$$\eta_{k+1} = \frac{\eta_k}{\alpha_1^2} - \frac{g_1}{\alpha_1^{k+2}} z_{1,k+1} \quad (27)$$

We note that

$$\frac{\eta_k}{\alpha_1^2} = \frac{\eta_k}{\alpha_1^4} + (\frac{g_1}{\alpha_1^{k+2}})^2 \sigma_1^2 \quad (28)$$

$$= \frac{\sigma_1^2}{\alpha_1^{2(k+1)}} \quad (29)$$

In (29) we have made use of (16).

At time $k+1$, receiver 2 gets

$$y_{2,k+1} = x_{k+1} + z_{1,k+1} + z_{2,k+1} = g_1 \alpha_1^k \eta_k + g_2 \alpha_2^k \xi_k + z_{1,k+1} + z_{2,k+1} \quad (30)$$

It also has the old estimate

$$\hat{\theta}_{2,k} = \theta_2 + \xi_k. \quad (31)$$

Subtracting $\frac{1}{g_2 \alpha_2^k} y_{2,k+1}$ from $\hat{\theta}_{2,k}$ yields

$$\theta_2 - \frac{g_1 \alpha_1^k}{g_2 \alpha_2^k} \eta_k - \frac{1}{g_2 \alpha_2^k} (z_{1,k+1} + z_{2,k+1}). \quad (32)$$

We then form

$$\begin{aligned} \hat{\theta}_{2,k+1} &= \frac{(31) + g_2^2 (32)}{1 + g_2^2} = \theta_2 + \frac{\xi_k}{\alpha_2^2} - \frac{g_1 g_2 \alpha_1^k}{\alpha_2^{k+2}} \eta_k \\ &\quad - \frac{g_2}{\alpha_2^{k+2}} (z_{1,k+1} + z_{2,k+1}) \end{aligned} \quad (33)$$

Comparing (33) with (15) we obtain

$$\xi_{k+1} = \frac{\xi_k}{\alpha_2^2} - \frac{g_1 g_2 \alpha_1^k}{\alpha_2^{k+2}} \eta_k - \frac{g_2}{\alpha_2^{k+2}} (z_{1,k+1} + z_{2,k+1}) \quad (34)$$

Making use of (16), (17) and (18) it can be easily shown that

$$\overline{\xi_{k+1}^2} = \frac{b_k^2 + g_1^2 g_2^2 \sigma_1^2 + g_2^2 (\sigma_1^2 + \sigma_2^2)}{\alpha_2^{2(k+2)}} \quad (35)$$

Comparison of (35) with (17) yields

$$\begin{aligned}
 b_{k+1}^2 &= \frac{1}{\alpha_2} [b_k^2 + g_1^2 g_2^2 \sigma_1^2 + g_2^2 (\sigma_1^2 + \sigma_2^2)] \\
 &= \frac{1}{\alpha_2} [b_k^2 + g_2^2 (\alpha_1^2 \sigma_1^2 + \sigma_2^2)] \\
 &= \frac{1}{\alpha_2} [b_k^2 + g_2^2 b^2]
 \end{aligned} \tag{36}$$

Note that since $b_k^2 \leq b^2$ by (17),

$$b_{k+1}^2 \leq \frac{1}{\alpha_2} (b^2 + g_2^2 b^2) = b^2. \tag{37}$$

Finally it can be seen that

$$\begin{aligned}
 \overline{\eta_{k+1} \xi_{k+1}} &= - \frac{g_1 g_2 \alpha_1^{k-2}}{\alpha_2^{k+2}} \overline{\eta_k} + \frac{g_1 g_2}{\alpha_1^{k+2} \alpha_2^{k+2}} \overline{z_{1,k+1}^2} \\
 &= - \frac{g_1 g_2 \sigma_1^2}{\alpha_2^{k+2} \alpha_1^{k+2}} + \frac{g_1 g_2 \sigma_1^2}{\alpha_1^{k+2} \alpha_2^{k+2}} = 0.
 \end{aligned} \tag{38}$$

After the initial step, equations (14) through (18) hold with $d_0 = c_0 = 0$, and $b_0 = \sigma_1^2 + \sigma_2^2 (\leq b^2)$. Thus by induction equations (14) through (18) hold for $k=1,2,3,\dots$

2.1.2 Achievable Rates for Reliable Transmission

Recapitulating the main results of the previous section, we observe that at time N ,

$$\hat{\theta}_{1,N} = \theta_1 + c_N \theta_2 - d_N + \eta_N \quad (39)$$

$$\hat{\theta}_{2,N} = \theta_2 + \xi_N \quad (40)$$

where η_N and ξ_N are Gaussian random variables with means 0 and variances

$\frac{\sigma_1^2}{2N}$ and $\frac{b_N^2}{2N}$ respectively. c_N and d_N can be computed recursively by (25) and

(26) and the fact that $c_0 = d_0 = 0$. To compute the error probability at the second receiver, we note that this is equal to the probability that $\hat{\theta}_{2,N}$ lies outside

the correct message interval of length $\frac{1}{M_2}$. Thus $P_{e,2} = 2 Q \left(\frac{\alpha_2^N}{2M_2 b_N} \right)$ where $Q(\alpha) = \int_{\alpha}^{\infty} \frac{1}{\sqrt{2\pi}} e^{-\frac{x^2}{2}} dx$. Since $b_N \leq b$, we can upperbound $P_{e,2}$ by

$$P_{e,2} \leq 2 Q \left(\frac{\alpha_2^N}{2M_2 b} \right) \quad (41)$$

$$= 2 Q \left(\frac{\alpha_2^N}{2M_2 \sqrt{\alpha_1^2 \sigma_1^2 + \sigma_2^2}} \right) \quad (42)$$

If we let $M_2 = \alpha_2^{N(1-\epsilon)}$, $\epsilon > 0$, then $P_{e,2} \rightarrow 0$ as $N \rightarrow \infty$. So by making N large enough, we can transmit reliably at a rate as close as desired to

$$\begin{aligned} R_2^* &= \frac{\ln \alpha_2^N}{T} = \frac{\ln \alpha_2^{2TW}}{T} \\ &= W \ln \alpha_2^2 \\ &= W \ln(1+g_2^2) \text{ nats/second.} \end{aligned} \quad (43)$$

Now receiver 1 can learn Θ_2 with arbitrarily small probability of error.

Conditioned on the event that receiver 1 correctly guesses Θ_2 , his probability of error is

$$P_{e,1}^* = 2 Q \left(\frac{\alpha_1^N}{2M_1\sigma_1} \right) \quad (44)$$

as can be seen from (39).

Using the union bound, we can upperbound receiver 1's overall error probability by

$$P_{e,1} \leq P_{e,1}^* + P_{e,2} \quad (45)$$

A similar argument to that used above shows that we can transmit reliably to receiver 1 at a limiting rate

$$R_1^* = W \ln(1+g_1^2) \text{ nats/second} \quad (46)$$

We now proceed to relate R_1^* and R_2^* to the average power constraint P .

We recall that at time $k+1$ the transmitter sends

$$X_{k+1} = g_1 \alpha_1^k \eta_k + g_2 \alpha_2^k \xi_k, \quad k = 1, 2, 3, \dots, N-1. \quad (47)$$

The variance of X_{k+1} is

$$\overline{X_{k+1}^2} = g_1^2 \sigma_1^2 + g_2^2 b_k^2. \quad (48)$$

Assuming a uniform prior distribution for Θ_1 and Θ_2 ,

$$\overline{X_{-1}^2} = \overline{X_0^2} = \frac{1}{12}. \quad (49)$$

Thus the average power is

$$P_{av} = \frac{1}{T} \left\{ \frac{1}{6} + \sum_{k=0}^{N-1} g_1^2 \sigma_1^2 + g_2^2 b_k^2 \right\} \quad (50)$$

$$\leq \frac{2W}{N+2} \left[\frac{1}{6} + N (g_1^2 \sigma_1^2 + g_2^2 b^2) \right] \quad (51)$$

Asymptotically,

$$P_{av} \leq 2W \left[g_1^2 \sigma_1^2 + g_2^2 (\alpha_1^2 \sigma_1^2 + \sigma_2^2) \right] \quad (52)$$

We need $P_{av} \leq P$. This condition is satisfied if (substituting $\frac{N_1}{2}$ and $\frac{N_2}{2}$ for σ_1^2 and σ_2^2 in (52))

$$g_1^2 N_1 + g_2^2 (\alpha_1^2 N_1 + N_2) \leq \frac{P}{W} \quad (53)$$

Now let $g_1^2 = \frac{\alpha P}{N_1 W}$ where $\alpha \in [0, 1]$. Then (53) implies

$$\frac{\alpha P}{W} + g_2^2 \left[\frac{\alpha P}{W} + N_1 + N_2 \right] \leq \frac{P}{W} \quad (54)$$

$$\text{i.e. } g_2^2 \leq \frac{\bar{\alpha} P}{\alpha P + (N_1 + N_2) W}, \quad \bar{\alpha} = 1 - \alpha \quad (55)$$

Substitution of g_1^2 and g_2^2 back into (46) and (43) shows that all rate pairs (R_1, R_2) such that

$$R_1 \leq W \ln \left(1 + \frac{\alpha P}{N_1 W} \right) \quad (56)$$

$$R_2 \leq W \ln \left(1 + \frac{\bar{\alpha} P}{\alpha P + (N_1 + N_2) W} \right)$$

are achievable.

2.2 Independent Broadcast Channel

The scheme described above can also be applied to a broadcast channel where the receiver's noises are independent, as depicted in Figure 2. Note that we assume that one receiver has access to the other's feedback signal. In contrast to model 1, the additional information available to receiver 1, in the form of receiver 2's feedback, is usable in improving his estimate of the transmitted number.

The analysis of this situation is reasonably similar to that presented in Section 2.1, and is given in the appendix. It is shown in the appendix that equations (14), (15) and (18) apply as before, but that

$$\overline{\eta_k^2} = \frac{\sigma_e^2}{\alpha_1 2k} \quad (57)$$

and

$$\overline{\xi_k^2} = \frac{b_k^2}{\alpha_2 2k}, \quad b_k^2 \leq b^2 = g_1^2 \sigma_1^2 + \sigma_2^2 \quad (58)$$

where

$$\sigma_e^2 = \frac{\sigma_1^2 \sigma_2^2}{\sigma_1^2 + \sigma_2^2} \quad (59)$$

(Note that in model one, the total noise to receiver 2 is $\sigma_1^2 + \sigma_2^2$; here it is σ_2^2 . Indeed the assumption that the link from transmitter to receiver 2 is noisier than that from the transmitter to receiver 1, while intrinsic to model one, is not made for model 2.)

Using (18), (57), (58) and arguments similar to those used in Section 2.1 we obtain that all points within the region described by

$$R_1 \leq W \ln \left(1 + \frac{\alpha P}{W} \left(\frac{1}{N_1} + \frac{1}{N_2} \right) \right)$$

$$R_2 \leq W \ln \left(1 + \frac{\alpha P}{\alpha P + N_2 W} \right) \quad (60)$$

$$\alpha \in [0, 1], N_1 = \sigma_1^2, N_2 = \sigma_2^2.$$

are obtainable.

This is the capacity region of the model. Although not the usual degraded AWGN broadcast channel, the communication problem defined by Figure 2 is a degraded broadcast channel, since at each time receiver 1 has access to channel outputs y_1 and y_2 , while receiver 2's channel output, y_2 , is equivalent to having passed y_1 and y_2 through a two input-two output channel, by which one input (y_2) is passed unchanged and the other (y_1) obliterated.

Since the channel is degraded, the results of [16], in which it was shown that feedback does not increase the capacity region for a degraded channel, apply. Thus the rate region for Figure 2 is unaffected if the feedback links to the transmitter are removed. Since $y_{1,i}$ and $y_{2,i}$ are obtained by adding independent Gaussian noises to x_i , then it is simply shown that

$$p(x_i | y_{1,i}, y_{2,i}) = p(x_i | z_i) \quad (61)$$

where

$$z_i = \frac{\sigma_2^2 y_{1,i} + \sigma_1^2 y_{2,i}}{\sigma_1^2 + \sigma_2^2} \quad (62)$$

for any a priori distribution on x_i . Therefore the joint distribution of the useful information to receiver one and receiver two is equivalent to that of a degraded AWGN broadcast channel for which receiver 1's noise has variance

$$\frac{\sigma_1^2 \sigma_2^2}{\sigma_1^2 + \sigma_2^2} \text{ and receiver 2's has variance } \sigma_2^2. \text{ The capacity region for this}$$

situation is given by (60). Details of the proof are given in [17].

3. The AWGN Multiple - Access Channel

In this section, we first recall the capacity region of the AWGN multiple-access channel with no feedback. We then examine the same channel when feedback is allowed and analyze the performance of a proposed deterministic feedback coding scheme.

The AWGN multiple-access channel is the most commonly studied continuous alphabet channel. The output signal Y is the sum $X_1 + X_2 + Z$ where X_1 and X_2 are the input signals and Z is a zero-mean Gaussian (noise) random variable independent of X_1 and X_2 , with variance $EZ^2 = \sigma^2$. There are average power constraints P_1 and P_2 on the inputs. The capacity region for the AWGN multiple-access channel with no feedback allowed has been determined by Cover [12] and Wyner [13] to be the set of all rate pairs $\underline{R} = (R_1, R_2)$ satisfying

$$\begin{aligned} R_1 &\leq 1/2 \log_2 \left(1 + \frac{P_1}{\sigma^2} \right) \text{ bits/transmission} \\ R_2 &\leq 1/2 \log_2 \left(1 + \frac{P_2}{\sigma^2} \right) \\ R_1 + R_2 &\leq 1/2 \log_2 \left(1 + \frac{P_1 + P_2}{\sigma^2} \right). \end{aligned} \tag{63}$$

It has been shown by Gaarder and Wolf [14] and Cover and Leung [15] that in general feedback will enlarge the capacity region of a multiple-access channel. The model of the AWGN multiple-access channel with feedback is shown in Figure 3.

As shown, θ_i is the message to be sent by transmitter i . $X_{1,n}$ and $X_{2,n}$ are the outputs of transmitters 1 and 2 at time n . The corresponding output of the channel is denoted by Y_n . $X_{i,n}$, $i = 1, 2$, is a function of $(\theta_i, X_{i,1}, \dots, X_{i,n-1}, Y_1, \dots, Y_{n-1})$.

3.1 The Coding Scheme

The notation which will be used in this section is analogous to that introduced for the broadcast channel in section 2. We assume that sender i , $i = 1, 2$ wishes to send one of M_i messages to the receiver. Again, for sender i , we divide the unit interval $[0, 1]$ into M_i disjoint message intervals of equal length. θ_i is the mid-point of the message interval corresponding to the message of sender i .

3.1.1 Initialization

The initialization procedure is done at times -1 and 0 . At time -1 , the first encoder (or transmitter) T_1 sends θ_1 and the second encoder T_2 sends 0 . At time 0 , T_1 sends 0 and T_2 sends θ_2 . The corresponding channel outputs are

$$Y_{-1} = \theta_1 + Z_{-1} \quad (64)$$

and

$$Y_0 = \theta_2 + Z_0 \quad (65)$$

Thus at the end of this initialization period, the receiver's error in estimating θ_1 is $\eta_1 = Z_{-1}$ and its error in estimating θ_2 is $\xi_1 = Z_0$. We note that η_1 and ξ_1 are jointly Gaussian random variables with

$$\eta_1^2 = \xi_1^2 = \sigma^2 \quad \text{and} \quad \overline{\eta_1 \xi_1} = 0.$$

3.1.2 Procedure at time k

We now assume that after time k-1 the receiver has computed estimates of θ_1 and θ_2 , namely

$$\hat{\theta}_{1,k} = \theta_1 + \eta_k \quad (66)$$

and

$$\hat{\theta}_{2,k} = \theta_2 + \xi_k.$$

At time k, the first transmitter T_1 sends

$$x_{1,k} = \sqrt{\frac{P_1}{a_k}} \eta_k \quad (67)$$

and T_2 sends

$$x_{2,k} = (\text{sgn } \rho_k) \sqrt{\frac{P_2}{b_k}} \xi_k \quad (68)$$

$$\text{where } a_k = \overline{\eta_k^2}, \quad b_k = \overline{\xi_k^2}, \quad \rho_k = \frac{\overline{\eta_k \xi_k}}{\sqrt{a_k b_k}} \quad (69)$$

$$\text{and } \text{sgn } \rho_k = \begin{cases} +1, & \rho_k \geq 0 \\ -1, & \rho_k < 0 \end{cases} \quad (70)$$

After time k, the receiver has $\hat{\theta}_{1,k}$, $\hat{\theta}_{2,k}$ and

$$y_k = \sqrt{\frac{P_1}{a_k}} \eta_k + (\text{sgn } \rho_k) \sqrt{\frac{P_2}{b_k}} \xi_k + z_k. \quad (71)$$

To estimate θ_1 , the receiver first forms

$$\begin{aligned}\hat{\hat{\theta}}_{1,k} &= \hat{\theta}_{1,k} - \sqrt{\frac{a_k}{P_1}} y_k \\ &= \theta_1 - (\text{sgn } \rho_k) \sqrt{\frac{a_k P_2}{b_k P_1}} \xi_k - \sqrt{\frac{a_k}{P_1}} z_k.\end{aligned}\quad (72)$$

It now forms its new estimate $\hat{\theta}_{1,k+1}$ of θ_1 based on $\hat{\theta}_{1,k}$ and $\hat{\hat{\theta}}_{1,k}$ as

$$\hat{\theta}_{1,k+1} = \frac{(\hat{\sigma}_{1,k}^2 - \lambda_k) \hat{\theta}_{1,k} + (\hat{\hat{\sigma}}_{1,k}^2 - \lambda_k) \hat{\hat{\theta}}_{1,k}}{\hat{\sigma}_{1,k}^2 + \hat{\hat{\sigma}}_{1,k}^2 - 2\lambda_k}\quad (73)$$

where $\hat{\sigma}_{1,k}^2 \triangleq \text{var}(\hat{\theta}_{1,k} - \theta_1) = a_k$ (74)

$$\hat{\hat{\sigma}}_{1,k}^2 \triangleq \text{var}(\hat{\hat{\theta}}_{1,k} - \theta_1) = \frac{a_k}{P_1} (P_2 + \sigma^2)$$
 (75)

and $\lambda_k = \frac{(\hat{\theta}_{1,k} - \theta_1)(\hat{\hat{\theta}}_{1,k} - \theta_1)}{(\hat{\theta}_{1,k} - \theta_1)^2 + (\hat{\hat{\theta}}_{1,k} - \theta_1)^2} = -a_k \sqrt{\frac{P_2}{P_1}} |\rho_k|$. (76)

We define η_{k+1} by

$$\hat{\theta}_{1,k+1} = \theta_1 + \eta_{k+1}.$$
 (77)

Then a straightforward but tedious calculation shows that

$$a_{k+1} \triangleq \frac{\eta_{k+1}^2}{2} = \frac{[P_2(1-\rho_k^2) + \sigma^2] a_k}{P_1 + P_2 + \sigma^2 + 2\sqrt{P_1 P_2} |\rho_k|} \triangleq \alpha_k a_k$$
 (78)

Also

$$\eta_{k+1} = \eta_k - \frac{(P_1 + \sqrt{P_1 P_2} |\rho_k|) \left[\eta_k + \sqrt{\frac{a_k}{P_1}} \left(\sqrt{\frac{P_2}{b_k}} (\text{sgn } \rho_k) \xi_k + z_k \right) \right]}{P_1 + P_2 + \sigma^2 + 2\sqrt{P_1 P_2} |\rho_k|} \quad (79)$$

The receiver's new estimate $\hat{\theta}_{2,k+1}$ of θ_2 is obtained by first calculating

$$\hat{\theta}_{2,k+1} = \hat{\theta}_{2,k} - (\text{sgn } \rho_k) \sqrt{\frac{P_2}{b_k}} y_k \quad (80)$$

and then proceeding in a way analogous to getting its new estimate of θ_1 .

Once again, a laborious calculation yields

$$b_{k+1} \triangleq \overline{\xi_{k+1}^2} = \frac{[P_1(1-\rho_k^2) + \sigma^2] b_k}{P_1 + P_2 + \sigma^2 + 2\sqrt{P_1 P_2} |\rho_k|} \triangleq \beta_k b_k \quad (81)$$

and

$$\xi_{k+1} = \xi_k - \frac{(P_2 + \sqrt{P_1 P_2} |\rho_k|) \left[\xi_k + \sqrt{\frac{P_1}{a_k}} (\text{sgn } \rho_k) \eta_k + (\text{sgn } \rho_k) z_k \right]}{P_1 + P_2 + \sigma^2 + 2\sqrt{P_1 P_2} |\rho_k|} \quad (82)$$

Finally, it can be shown that

$$\rho_{k+1} = \frac{\sigma^2 \rho_k - \sqrt{P_1 P_2} (\text{sgn } \rho_k) (1-\rho_k^2)}{\sqrt{\{\sigma^2 + P_2(1-\rho_k^2)\} \{\sigma^2 + P_1(1-\rho_k^2)\}}} \quad (83)$$

3.2 Achievable Rates for Reliable Transmission

The results of the previous section show that at time N , the estimates of θ_1 and θ_2 are

$$\hat{\theta}_{1,N} = \theta_1 + \eta_N$$

and

$$\hat{\theta}_{2,N} = \theta_2 + \xi_N, \quad (84)$$

where η_N and ξ_N are jointly Gaussian random variables with zero means and variances $\sigma^2 \prod_{n=1}^{N-1} \alpha_n$ and $\sigma^2 \prod_{n=1}^{N-1} \beta_n$ respectively.

The error probability $P_{e,1}$ in decoding Θ_1 is equal to the probability that $\hat{\Theta}_{1,N}$ lies outside the correct message interval of length $\frac{1}{M_1}$, i.e.,

$$P_{e,1} = 2 \Omega \left(\frac{1}{2M_1 \sigma \sqrt{\prod_{n=1}^{N-1} \alpha_n}} \right) \quad (85)$$

Similarly, the error probability in decoding Θ_2 is given by

$$P_{e,2} = 2 \Omega \left(\frac{1}{2M_2 \sigma \sqrt{\prod_{n=1}^{N-1} \beta_n}} \right) \quad (86)$$

Let $\lim_{n \rightarrow \infty} \alpha_n = \alpha_\infty$ and $\lim_{n \rightarrow \infty} \beta_n = \beta_\infty$. Then by making N large enough, the receiver can decode Θ_1 with arbitrarily small error probability as long as the rate of transmission R_1 satisfies

$$R_1 \triangleq \frac{\log_2 M_1}{N} < 1/2 \log_2 \frac{1}{\alpha_\infty} \quad \text{bits/transmission} \quad (87)$$

Similarly, Θ_2 can be reliably decoded if

$$R_2 \triangleq \frac{\log_2 M_2}{N} < 1/2 \log_2 \frac{1}{\beta_\infty} \quad \text{bits/transmission} \quad (88)$$

3.3 Numerical Results

In order to obtain numerical results, let us consider the case when $P_1 = P_2 = \sigma^2$. Then (83) reduces to

$$\rho_{k+1} = \frac{\rho_k - (1-\rho_k^2) \text{sgn } \rho_k}{2 - \rho_k^2} \quad (89)$$

It was found by iteration using (89) that ρ_k , $k = 2, 3, \dots$ alternates in sign and $\lim_{k \rightarrow \infty} |\rho_k| = 0.31111$.

Using this in (78) and (81) we obtain

$$\alpha_{\infty} = \beta_{\infty} = 0.5254. \quad (90)$$

(87) and (88) then show that reliable transmission from the two transmitters to the receiver is possible at rates R_1 and R_2 where

$$R_1 = R_2 = 0.4642 \text{ bits/transmission}. \quad (91)$$

For comparison, we note that for this example, the Cover-Leung scheme in [7] can achieve

$$R_1 = R_2 = 0.4353 \text{ bits/transmission} \quad (92)$$

The total co-operation upperbound gives

$$R_1 = R_2 = 0.5805 \text{ bits/transmission}. \quad (93)$$

The best equal rate pair that can be achieved with no feedback link is $R_1 = R_2 = 0.3962$ bits.

4. Discussion

Deterministic coding schemes for two models of the AWGN broadcast channel with feedback were examined. The schemes allow reliable transmission at all rate pairs within the capacity regions of the corresponding AWGN channel without feedback. These regions are identical to the capacity regions of the models examined [16, 17].

At each iteration after the initialization period, the "corrections" sent by the transmitter to the two receivers are suitably amplified and superimposed so that the expected power of each transmission is close to but bounded by $\frac{P}{2W}$. Receiver 1 gets a new estimate of his message $\hat{\theta}_1$ by

combining his new signal, his previous estimate of Θ_1 and his knowledge of receiver 2's estimate of Θ_2 . Receiver 2 updates his estimate of Θ_2 by combining his new signal with his previous estimate of Θ_2 .

We might point out that from (41), (42) and (45) it can be deduced that if $R_1 < C_1(\alpha)$ and $R_2 < C_2(\alpha)$, both $P_{e,1}$ and $P_{e,2}$ decay "doubly exponentially" to zero with N .

The two models treated here assume a unidirectional link between one receiver and the other. In [17], this assumption is discarded and a scheme is given which shows that feedback can enlarge the no-feedback capacity region if the broadcast channel is not degraded.

A deterministic scheme for the multiple-access channel with feedback was also analyzed. It is shown that this scheme achieves points that dominate the best achievable points known to date. Error rates for this model also decay to zero "doubly exponentially".

A complete solution for this multiple-access channel has been developed and will appear in [17]. In particular, the capacity region is derived. The scheme presented here achieves a point on the boundary of the capacity region.

APPENDIX: Analysis for Independent Channels (Model of Figure 2)

The primary change in the scheme for the model is that after the i^{th} transmission, receiver 1 can improve his estimate of x_i by combining his channel output with receiver 2's channel output. That is receiver 1 has obtained

$$y_{1,k} = x_k + z_{1,k} \quad (\text{A.1})$$

and

$$y_{2,k} = x_k + z_{2,k} \quad (\text{A.2})$$

He then forms his best estimate of x_k

$$y'_{1,k} = (\sigma_2^2 y_{1,k} + \sigma_1^2 y_{2,k}) / (\sigma_2^2 + \sigma_1^2) \quad (\text{A.3})$$

(This applies also to the initialization step.)

Therefore after initialization

$$\hat{\epsilon}_{1,0} = \theta_1 - \frac{\sigma_2^2 z_{1,-1} + \sigma_1^2 z_{2,-1}}{\sigma_1^2 + \sigma_2^2} = \theta_1 + \eta_0 \quad (\text{A.4})$$

$$\hat{\epsilon}_{2,0} = \theta_2 - z_{2,0} = \theta_2 + \xi_0 \quad (\text{A.5})$$

$$\text{and } E[\eta_0^2] = \frac{\sigma_1^2 \sigma_2^2}{\sigma_1^2 + \sigma_2^2} \triangleq \sigma_e^2 \quad (\text{A.6})$$

$$E[\xi_0^2] = \sigma_2^2 \quad (\text{A.7})$$

$$E[\eta_0 \xi_0] = 0 \quad (\text{A.8})$$

After time k , we assume once again that equations (14), (15) and (18) hold, but that

$$\frac{\sigma_e^2}{\eta_k^2} = \frac{\sigma_e^2}{\alpha_1^{2k}} \quad (\text{A.9})$$

$$\frac{b_k^2}{\xi_k^2} = \frac{b_k^2}{\alpha_2^{2k}}, \quad b_k^2 \leq b^2 = \sigma_1^2 \sigma_e^2 + \sigma_2^2 \quad (\text{A.10})$$

If we adapt the arguments of section 2.1.1 allowing receiver 1 to use $y'_{1,k}$ to upgrade his estimate of θ_1 , and remembering that receiver 2's noise is independent of receiver 1's, we obtain the following recursive expressions for η_{k+1} and ξ_{k+1}

$$\eta_{k+1} = \frac{\eta_k}{\alpha_1^2} - \frac{g_1}{\alpha_1^{k+2}} \frac{\sigma_2^2 z_{1,k+1} + \sigma_1^2 z_{2,k+1}}{\sigma_1^2 + \sigma_2^2} \quad (\text{A.11})$$

$$\xi_{k+1} = \frac{\xi_k}{\alpha_2^2} - \frac{g_1 g_2 \alpha_1^k \eta_k}{\alpha_2^{k+2}} - \frac{g_2}{\alpha_2^{k+2}} z_{2,k+1} \quad (\text{A.12})$$

Assuming that (A.9) and (A.10) hold as well as (18), we obtain that

$$\overline{\eta_{k+1}^2} = \frac{\sigma_e^2}{\alpha_1^{2k+4}} + \frac{g_1^2}{\alpha_1^{2k+4}} \sigma_e^2 = \frac{\sigma_e^2}{\alpha_1^{2k+2}} \quad (\text{A.13})$$

$$\begin{aligned} \overline{\xi_{k+1}^2} &= \frac{\overline{\xi_k^2}}{\alpha_2^4} + \frac{g_1^2 g_2^2 \alpha_1^{2k} \overline{\eta_k^2}}{\alpha_2^{2k+4}} + \frac{g_2^2 \sigma_2^2}{\alpha_2^{2k+4}} \\ &= \frac{b_k^2}{\alpha_2^{2k+4}} + \frac{g_1^2 g_2^2 \sigma_e^2}{\alpha_2^{2k+4}} + \frac{g_2^2 \sigma_2^2}{\alpha_2^{2k+4}} \\ &\leq \frac{b^2 + g_2^2 (\sigma_2^2 + \alpha_1^2 \sigma_e^2)}{\alpha_2^{2k+4}} \\ &= \frac{b^2}{\alpha_2^{2k+2}} \end{aligned} \quad (\text{A.14})$$

Also:

$$\begin{aligned} \overline{\eta_{k+1} \xi_{k+1}} &= - \frac{g_1 g_2 \alpha_1^k \overline{\eta_k^2}}{\alpha_1^2 \alpha_2^{k+2}} + \frac{g_1 g_2}{\alpha_1^{k+2} \alpha_2^{k+2}} \frac{\sigma_1^2}{\sigma_1^2 + \sigma_2^2} \sigma_2^2 \\ &= - \frac{g_1 g_2 \sigma_e^2}{\alpha_1^{k+2} \alpha_2^{k+2}} + \frac{g_1 g_2 \sigma_e^2}{\alpha_1^{k+2} \alpha_2^{k+2}} \\ &= 0 \end{aligned} \quad (\text{A.15})$$

Note also that the same recursions apply to c_k and d_k that did in the degraded case.

Since equation (A.9), (A.10), and (18) apply to η_0 and ξ_0 , they apply to η_k and ξ_k for all k , by induction.

References

- [1] C. E. Shannon, "Two-Way Communication Channels," Proc. 4th Berkeley Symp. Math. Statist. and Prob., Vol. 1, pp. 611-644, 1961. Reprinted in Key Papers in the Development of Information Theory, (D.Slepian, Ed.) New York: IEEE Press, pp. 339-372, 1974.
- [2] E. C. Van der Meulen, "A Survey of Multi-Way Channels in Information Theory: 1961 - 1976," IEEE Trans. on Information Theory, Vol. IT-23, pp. 1 - 37, January 1977.
- [3] T. M. Cover "Broadcast Channels," IEEE Trans. on Information Theory, Vol. IT-18, pp. 2-14, January 1972.
- [4] D. Slepian and J. K. Wolf, "A Coding Theorem for Multiple-Access Channels with Correlated Sources," The Bell System Technical Journal, Vol. 52, pp. 1037 - 1076, September 1973.
- [5] R. Ahlswede, "Multi-way Communication Channels," Proc. of the 2nd International Symposium on Information Transmission, Tsahkadsor, Armenia, USSR, Hungarian Press, 1971.
- [6] H. Liao, "Multiple-Access Channels," Ph.D. dissertation, Dept. of Electrical Engineering, University of Hawaii, Honolulu, 1972.
- [7] T. M. Cover and S.K. Leung-Yan Cheong, "An Achievable Rate Region for the Multiple-Access Channel with Feedback," submitted for publication.
- [8] P. P. Bergmans, "Random Coding Theorem for Broadcast Channels with Degraded Components," IEEE Trans. on Information Theory, Vol. IT-19, pp. 197-207, March 1973.
- [9] P. P. Bergmans, "A Simple Converse for Broadcast Channels with Additive White Gaussian Noise," IEEE Trans. on Information Theory, Vol. IT-20, pp.279-280, March 1974.
- [10] J.P.M. Schalkwijk and T. Kailath, "A Coding Scheme for Additive Noise Channels with Feedback - Part I: No Bandwidth Constraint," IEEE Trans. on Information Theory, Vol. IT-12, pp. 172-182, April 1966.
- [11] J. P. M. Schalkwijk, "A Coding Scheme for Additive Noise Channels with Feedback - Part II: Band-Limited Signals," IEEE Trans. on Information Theory, Vol. IT-12, pp. 183-189, April 1966.
- [12] T. M. Cover, "Some Advances in Broadcast Channels," Chapter in Advances in Communication Systems, Vol. 4, Theory and Applications, ed. by A. Viterbi, Academic Press, San Francisco, 1975.
- [13] A. D. Wyner, "Recent Results in the Shannon Theory," IEEE Trans. on Information Theory, Vol. IT-20, pp. 2-10, January 1974.

- [14] N. T. Gaarder and J. K. Wolf, "The Capacity Region of A Multiple-Access Discrete Memoryless Channel Can Increase With Feedback," IEEE Trans. on Information Theory, Vol. IT-21, pp. 100-102, January 1975.
- [15] T. M. Cover and S. K. Leung-Yan-Cheong, "A Scheme for Enlarging the Capacity Region of Multiple-Access Channels Using Feedback," Technical Report No. 17, Department of Statistics, Stanford University, March 1976.
- [16] El Gamal, "The Feedback Capacity of Degraded Broadcast Channels," IEEE Trans. on Information Theory, Vol. IT-24, pp. 379-381, May 1978.
- [17] L. H. Ozarow, Ph.D, Dissertation, Dept. of Electrical Engineering and Computer Science, Massachusetts Institute of Technology, (in press).

Distribution List

Defense Documentation Center Cameron Station Alexandria, Virginia 22314	12 Copies
Assistant Chief for Technology Office of Naval Research, Code 200 Arlington, Virginia 22217	1 Copy
Office of Naval Research Information Systems Program Code 437 Arlington, Virginia 22217	2 Copies
Office of Naval Research Branch Office, Boston 495 Summer Street Boston, Massachusetts 02210	1 Copy
Office of Naval Research Branch Office, Chicago 536 South Clark Street Chicago, Illinois 60605	1 Copy
Office of Naval Research Branch Office, Pasadena 1030 East Greet Street Pasadena, California 91106	1 Copy
New York Area Office (ONR) 715 Broadway - 5th Floor New York, New York 10003	1 Copy
Naval Research Laboratory Technical Information Division, Code 2627 Washington, D.C. 20375	6 Copies
Dr. A. L. Slafkosky Scientific Advisor Commandant of the Marine Corps (Code RD-1) Washington, D.C. 20380	1 Copy

Office of Naval Research Code 455 Arlington, Virginia 22217	1 Copy
Office of Naval Research Code 458 Arlington, Virginia 22217	1 Copy
Naval Electronics Laboratory Center Advanced Software Technology Division Code 5200 San Diego, California 92152	1 Copy
Mr. E. H. Gleissner Naval Ship Research & Development Center Computation and Mathematics Department Bethesda, Maryland 20084	1 Copy
Captain Grace M. Hopper NAICOM/MIS Planning Branch (OP-916D) Office of Chief of Naval Operations Washington, D.C. 20350	1 Copy
Mr. Kin B. Thompson Technical Director Information Systems Division (OP-91T) Office of Chief of Naval Operations Washington, D.C. 20350	1 Copy
Advanced Research Projects Agency Information Processing Techniques 1400 Wilson Boulevard Arlington, Virginia 22209	1 Copy
Dr. Stuart L. Brodsky Office of Naval Research Code 432 Arlington, Virginia 22217	1 Copy
Captain Richard L. Martin, USN Commanding Officer USS Francis Marion (LPA-249) FPO New York 09501	1 Copy