

AD-A068 254

AIR FORCE MATERIALS LAB WRIGHT-PATTERSON AFB OH
BRAZING OF HASTELLOY X WITH WIDE CLEARANCE BUTT JOINTS. (U)
MAR 79 J W CHASTEEN, G E METZGER

F/6 11/6

UNCLASSIFIED

AFML-TR-79-4026

NL

| OF |
AD
A0682 5A

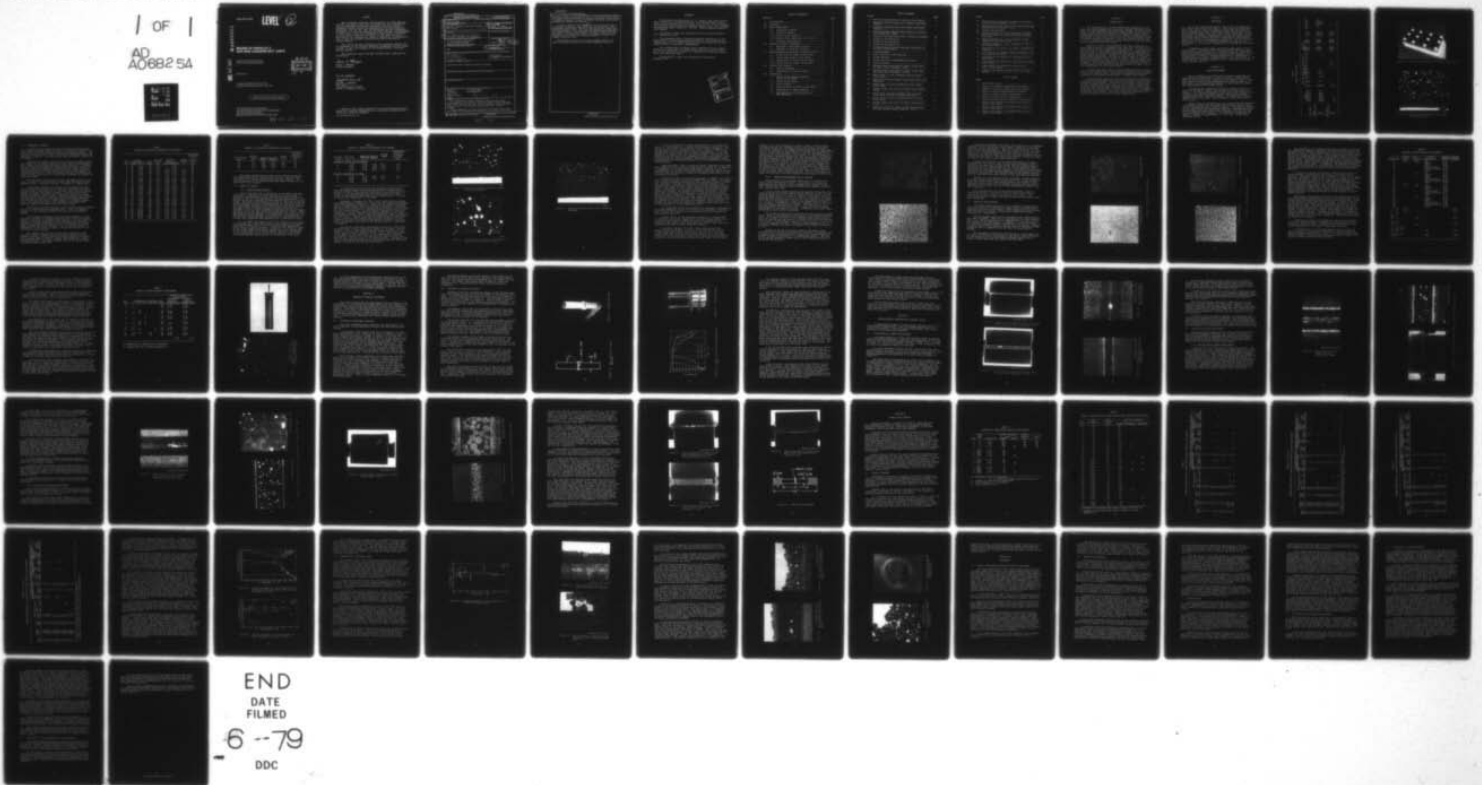



MICROCOPY RESOLUTION TEST CHART
NATIONAL BUREAU OF STANDARDS-1963-A

AFML-TR-79-4026

LEVEL

②

AD A 068254

**BRAZING OF HASTELLOY X
WITH WIDE CLEARANCE BUTT JOINTS**

*STRUCTURAL METALS BRANCH
METALS AND CERAMICS DIVISION*

MARCH 1979

TECHNICAL REPORT AFML-TR-79-4026
Final Report for Period January 1977 - July 1978

DDC
RECEIVED
MAY 7 1979
C

DDC FILE COPY

Approved for public release; distribution unlimited.

AIR FORCE MATERIALS LABORATORY
AIR FORCE WRIGHT AERONAUTICAL LABORATORIES
AIR FORCE SYSTEMS COMMAND
WRIGHT-PATTERSON AIR FORCE BASE, OHIO 45433

79 05 03 111

NOTICE

When Government drawings, specifications, or other data are used for any purpose other than in connection with a definitely related Government procurement operation, the United States Government thereby incurs no responsibility nor any obligation whatsoever; and the fact that the Government may have formulated, furnished, or in any way supplied the said drawings, specifications, or other data, is not to be regarded by implication or otherwise as in any manner licensing the holder or any other person or corporation, or conveying any rights or permission to manufacture, use, or sell any patented invention that may in any way be related thereto.

This report has been reviewed by the Information Office (IO) is releasable to the National Technical Information Service (NTIS). At NTIS, it will be available to the general public, including foreign nations.

This technical report has been reviewed and is approved for publication.

Guinn E. Metzger

GUINN E. METZGER
Project Engineer

FOR THE COMMANDER

Russell L. Kennard

RUSSELL L. KENNARD
Actg Chief,
Structural Metals Branch
Metals & Ceramics Division

Copies of this report should not be returned unless return is required by security considerations, contractual obligations, or notice on a specific document.

UNCLASSIFIED

SECURITY CLASSIFICATION OF THIS PAGE (When Data Entered)

REPORT DOCUMENTATION PAGE		READ INSTRUCTIONS BEFORE COMPLETING FORM
1. REPORT NUMBER 14 AFML-TR-79-4026	2. GOVT ACCESSION NO.	3. RECIPIENT'S CATALOG NUMBER
4. TITLE (and Subtitle) 6 Brazing of Hastelloy X with Wide Clearance Butt Joints	9	5. TYPE OF REPORT & PERIOD COVERED Final Report Jan 1977 - Jul 1978
7. AUTHOR(s) 10 Jack W. Chasteen and Guinn E. Metzger		6. PERFORMING ORG. REPORT NUMBER
9. PERFORMING ORGANIZATION NAME AND ADDRESS Air Force Materials Laboratory Air Force Systems Command Wright-Patterson AFB, Ohio 45433		8. CONTRACT OR GRANT NUMBER(s)
11. CONTROLLING OFFICE NAME AND ADDRESS Same	11	10. PROGRAM ELEMENT, PROJECT, TASK AREA & WORK UNIT NUMBERS Project No. 16 2747503 17 58
14. MONITORING AGENCY NAME & ADDRESS (if different from Controlling Office) 12 7A PI		12. REPORT DATE March 1979
		13. NUMBER OF PAGES
16. DISTRIBUTION STATEMENT (of this Report) Approved for public release; distribution unlimited.		15. SECURITY CLASS. (of this report) Unclassified
		15a. DECLASSIFICATION/DOWNGRADING SCHEDULE
17. DISTRIBUTION STATEMENT (of the abstract entered in Block 20, if different from Report)		
18. SUPPLEMENTARY NOTES		
19. KEY WORDS (Continue on reverse side if necessary and identify by block number) Brazing Gas Turbine Engine Nickel Alloy High Temperature Butt Joint Tensile Strength Repair		
20. ABSTRACT (Continue on reverse side if necessary and identify by block number) Wide clearance butt joints of Hastelloy X base metal were vacuum furnace brazed by first sintering a nickel base powder of high melting point (sinter filler metal) in the joint. This was followed by filling the powder interstices with a nickel base brazing filler metal and a diffusion treatment. Various combinations of sinter filler metals and brazing filler metals were studied by the production and examination of small wafers, which were		

DD FORM 1 JAN 73 1473

EDITION OF 1 NOV 65 IS OBSOLETE

UNCLASSIFIED

SECURITY CLASSIFICATION OF THIS PAGE (When Data Entered)

012 320

set

UNCLASSIFIED

SECURITY CLASSIFICATION OF THIS PAGE(When Data Entered)

sintered and brazed. These studies proved to be an efficient means of obtaining valuable information regarding the subsequent fabrication of brazed joints. A technique for brazing butt joints of consistent high quality, with virtually unlimited joint clearance, was developed.

The tensile strength at room temperature of brazed joints with sinter filler metal, at clearances greater than 6 mils, was far superior to that of conventionally brazed joints. The ductility was also better. Brazed joints containing Hastelloy C sinter filler metal and a NiCrBSi brazing filler metal had a tensile strength at room temperature and 1700° F of about 68% and 90%, respectively, of the base metal strength. The strength of these joints was maintained up to the largest joint clearance tested; i.e., 70 mils. The strength at 2000° F was 7 ksi.

The application of the sinter filler metal brazing technique to the repair and original fabrication of gas turbine components is discussed.

UNCLASSIFIED

SECURITY CLASSIFICATION OF THIS PAGE(When Data Entered)

FOREWORD

This report was prepared by Dr. G. Metzger, Structural Metals Branch, Metals and Ceramics Division, Air Force Materials Laboratory, Wright-Patterson Air Force Base, Ohio and Dr. Jack W. Chasteen, University of Dayton Research Institute, Dayton, Ohio. The research was performed under Project No. 2747503, "Engine Component Weld and Braze Repair".

The report covers work performed during the period January 1977 through July 1978.

The pioneering work of the Wall Colmonoy Corporation in the application of the brazing method described in this report and the helpful advice of Mr. Robert Peaslee during the course of the work reported here is gratefully acknowledged.

The authors wish to express their appreciation to Mr. Robert Leasure, Mr. Mark Dodd, Mr. Robert Leese, and Mr. Vincent Vidoni, all of the University of Dayton, for conducting the brazing experiments and associated tasks.

This technical report was submitted by the authors November 1978.

ACCESSION for	Write Section <input checked="" type="checkbox"/>
NTIS	Buff Section <input type="checkbox"/>
DDC	
UNANNOUNCED	
JUSTIFICATION	
BY	DISTRIBUTION/AVAILABILITY CODES
Dist.	MAIL <input type="checkbox"/> SPECIAL <input type="checkbox"/>
A	

TABLE OF CONTENTS

Section	Page
I Introduction	1
II Materials	2
III Wafer Experiments	2
3.1 Sintering of Wafers	5
3.2 Brazing of Wafers	7
3.2.1 Sinter Filler Metal S1	7
3.2.2 Sinter Filler Metals S2, S3, and S4	12
3.3 Porosity Investigation	14
IV Brazing of Tensile Specimens	22
4.1 Specimen in Horizontal Position	22
4.2 Specimen in Vertical Position	23
V Metallographic Examination of Brazed Joints	27
5.1 Joints With No Sinter Filler Metal	27
5.2 Joints With Sinter Filler Metal	30
5.2.1 Joints With S1 Sinter Filler Metal	30
5.2.2 Joints With S2 Sinter Filler Metal	33
VI Tensile Test Results	41
6.1 Tensile Strength	41
6.2 Examination of Fracture Faces	50
VII Discussion	56
7.1 Sinter Filler Metals Versus No Sinter Filler Metal	56
7.2 Sinter Filler Metals	57
7.3 Wafer Studies	58
7.4 Porosity With S1 Sinter Filler Metal	59
7.5 Application to Repair Brazing	60
7.6 Application to the Fabrication of New Components	61

LIST OF FIGURES

Figure		Page
1	Mold for Forming Wafers of Sinter Filler Metal ...	4
2	Brazed S1 Microstructure With Highest Calculated Porosity	4
3	Brazed S1 Microstructure With Lowest Calculated Porosity	9
4	Brazed Specimen Showing Relationship of Porosity and Interstitial Phase	9
5	Brazed S1 Microstructure After Diffusion Treatment	10
6	Brazed S2 Microstructure	13
7	Brazed S3 Microstructure	15
8	Brazed S4 Microstructure	16
9	Brazed Microstructure of Specimen Containing No S1 Sinter Filler Metal	21
10	Assembly Fixture	21
11	Cross Section of Braze Specimen	24
12	Brazed Specimen	24
13	Sinter and Braze Time-Temperature Cycle	25
14	Brazing Fixture	25
15	Typical Braze Joint With No Sinter Filler Metal for Small Joint Clearance, 9 mil	28
16	Typical Braze Joint With No Sinter Filler Metal for Large Joint Clearance, 23 mil	28
17	Braze Joint of 3-mil Clearance With No Sinter Filler Metal	29
18	Braze Joint With No Sinter Filler Metal and 5-mil Clearance	29
19	Braze Joint of 9-mil Clearance With No Sinter Filler Metal	31
20	Typical Braze Joint With S1 Sinter Filler Metal, 15 mil	32
21	Braze Joint of 8-mil Clearance With S1 Sinter Filler Metal Containing Cracks and Voids	34
22	Braze Joint of 46 mil Clearance With S1 Sinter Filler Metal	35
23	Typical Braze Joint With S2 Sinter Filler Metal 13 mil	36
24	Braze Joint With S2 Sinter Filler Metal Showing the Most Severe Porosity Observed, 16 mil	39

Figure		Page
25	Typical Braze Joint With S2 Sinter Filler Metal at Large Joint Clearance, 74 mil	39
26	Braze Joint With S2 Sinter Filler Metal Which Had Cracked Before Brazing, 67 mil	40
27	Tensile Test Specimen	40
28	Tensile Strength vs. Test Temperature for Base Metal and Braze Joints With a Nominal Clearance of 10 mils	49
29	Tensile Strength vs. Joint Clearance at Room Temperature for Braze Joints	49
30	Tensile Strength vs. Joint Clearance at 1700 °F for Brazed Joints	51
31	Cross Section of Fracture in Linear Intermetallic Compounds	52
32	Cross Section of Fracture Showing Incomplete Fill of Brazing Filler Metal	52
33	Cross Section of Fracture in Diffusion Zone of Base Metal	54
34	Cross Section of Fracture in Joint With S2 Sinter Filler Metal	54
35	Cross Section of Fracture in Joint With S1 Sinter Filler Metal	55
36	Fracture Face Showing Planar Failure at Faying Surface	55

LIST OF TABLES

Table		
1	Nickel Base Alloys	3
2	Results of Sintering Experiments With Wafers	6
3	Summary of Sintering Experiments With Wafers	7
4	Results of Brazing Experiments With Wafers	9
5	Results of Wafer Porosity Experiments	18
6	Results of Wafer Porosity Experiments	20
7	Tensile Test Results for Hastelloy X Base Metal ..	42
8	Tensile Test Results for Brazed Joints With No Sinter Filler Metal	43
9	Tensile Test Results for Brazed Joints With S1 Sinter Filler Metal	44
10	Tensile Test Results for Brazed Joints With S2 Sinter Filler Metal	46

SECTION I
INTRODUCTION

The increasing cost of high temperature components of aircraft gas turbine engines has resulted in greater interest in the repair of such components which have been damaged by service operation. Brazing has the potential of making these repairs more economically feasible by replacing the expensive manual labor of weld repair of each defect one by one with the simultaneous repair of multiple defects in many parts with each furnace brazing run. It is also sometimes possible to repair defects by brazing, which are not accessible for weld repair.

However, it must be demonstrated that the reliability of braze repaired parts is acceptable and that their service life is sufficient to be cost competitive with new parts. A primary cause for rejection of high temperature components is cracking due to tensile stresses created by nonuniform temperature distribution during engine operation. Brazing of these thermal fatigue cracks differs from conventional brazing in several respects: proper base metal cleaning is more difficult, wider joint clearances are often encountered, and the joint is loaded in tension rather than in shear. The welding engineer has very little freedom in the establishment of the brazing design and procedure to meet the service requirements of the brazed joints.

An investigation of two of these aspects peculiar to braze repair, wide joint clearances and tensile loading, was the purpose of the work reported here. Published information on the tensile properties of pertinent brazed joints is almost non-existent.

The base metal chosen for this investigation was Hastelloy X, a solid solution hardened nickel base alloy widely used for high temperature applications. The approach selected for the brazing of wide clearance butt joints was to first sinter a nickel base alloy of high melting point (referred to as sinter filler metal) in powder form in the joint, followed with filling of the powder interstices by brazing with a nickel base filler metal (referred to as brazing filler metal). The joint properties determined were tensile strength at room and elevated temperatures.

SECTION II

MATERIALS

All of the experimental metals used in this investigation were nickel base alloys, see Table 1. The Hastelloy X base metal was in the form of 9/16-inch diameter rolled rod, with material from two heats being used. The sinter filler metals were alloys of high melting point, including a NiCr alloy, Hastelloy C in two mesh sizes, and Rene' 80, designated S1 through S4, respectively. The brazing filler metals were alloys with melting point depressants of Si and/or B, designated B1 through B3. All of the filler metals were in the form of powders produced from the melt by atomization in a jet of gas; nitrogen for S1 through S3, and argon for S4.

A commercial liquid cement was used to make pastes of the filler metals. Analysis of the liquid indicated that the cement consisted of acrylic polymers in a volatile solvent, which was primarily trichloroethane with small amounts of what appeared to be ethylacetate, an alcohol, and methylethylketone. Measurements estimated that the acrylic polymers were 5.3 v/o and 4.8 w/o of the cement and had a specific gravity of 1.16. The specific gravity of the solvent was 1.30.

SECTION III

WAFER EXPERIMENTS

Basic information on sintering and brazing techniques was obtained by the fabrication of several series of molded wafers made of sinter filler metal, which were sintered or brazed. Data, which were of value in the subsequent joint brazing work, were more readily and economically produced in this manner than would have been possible with brazed joints.

The wafers were produced by forming a paste mixture of dry sinter filler metal, cement, and acetone in the mold shown in Figure 1. To facilitate removal of the wafers, the mold was made of Teflon with highly polished surfaces, holes with slightly tapered sides, and a removable bottom. The holes were 1-inch in diameter by 1/4-inch deep. The thickness of both Teflon sheets was 1/4-inch.

After drying of the wafers in air to volatilize the solvents, if sufficient cement had been added, the resulting green wafers could be handled carefully without breaking. The specific gravity of the green wafers was measured by means of a tungsten ballasted mercury immersion method and, after sintering, the specific gravity measurements were repeated. All sintering and brazing was done in a vacuum of approximately 1×10^{-5} Torr, except where otherwise stated.

TABLE 1
NICKEL BASE ALLOYS

	Common Designation	Nominal Chemical Composition, Balance Ni										Melting Temp. °F		S.G.	Mesh Size
		Cr	Fe	Co	Mo	W	Si	B	Al	Ti	Sol.	Liq.			
Base Metal	Hastelloy X	22	18	2	9	1						2350	2470	8.23	-
Sinter Filler Metal	-	20					1					2500	2575	8.24	-325
	Hastelloy C	16	6	2	16	4						2320	2380	8.94	-150/+325
	Hastelloy C	16	6	2	16	4						2320	2380	8.94	-325
	Rene 80	14	10	4	4			3	5			-	-	8.16	-100
Brazing Filler Metal	-	7	3		6	4.5	3					1790	1900	8.27	-
	B1	15					3.5					1930	1930	8.16	-
	B3	19				10						1975	2075	7.65	-

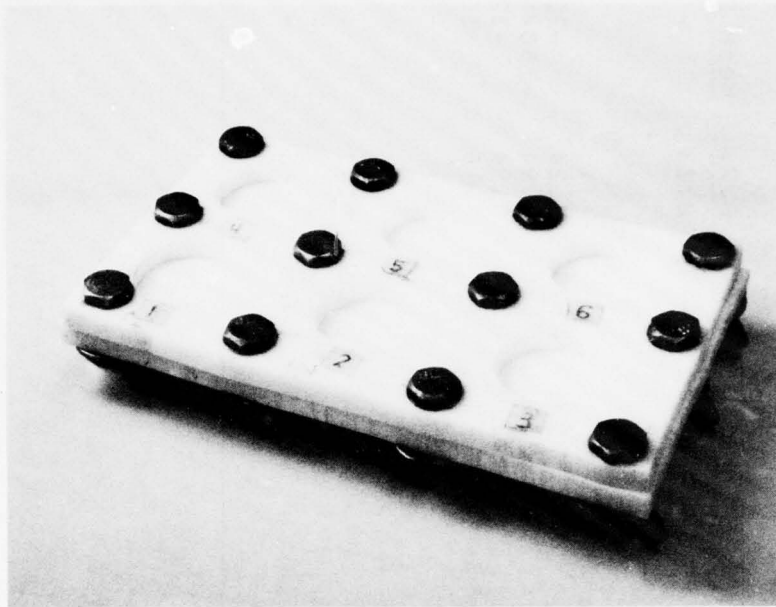

Figure 1. Mold for Forming Wafers of Sinter Filler Metal

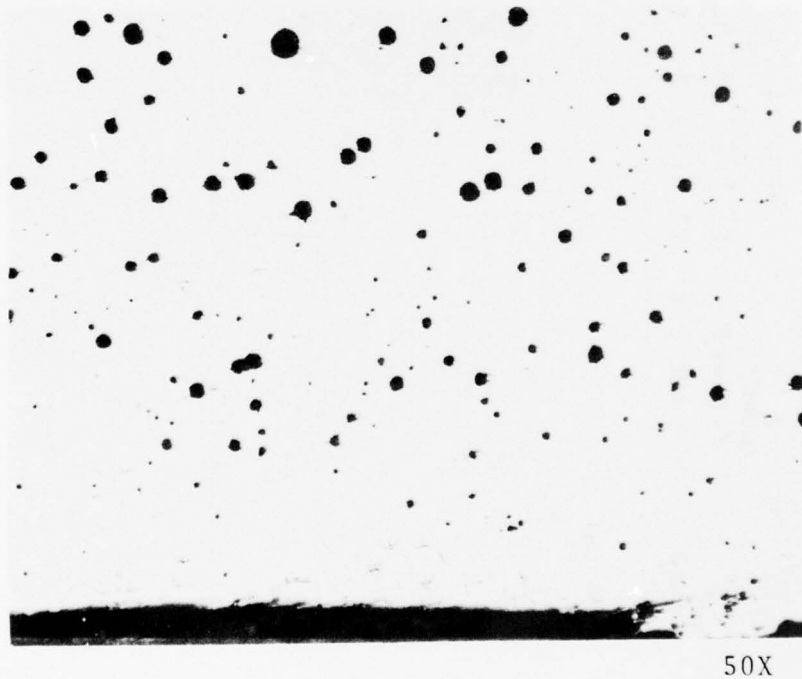

Figure 2. Brazed Si Microstructure with Highest Calculated Porosity

3.1 SINTERING OF WAFERS

A series of six wafers was made of sinter filled metal S1 with amounts of cement varying from 10 to 85 drops (0.0125 cm^3 per drop) plus sufficient acetone to render the mixture moldable. The 85 drops was the result of making the mixture moldable without the addition of acetone. The green wafers were sintered at 2065°F for 30 minutes.

The first two wafers, with 10 and 20 drops of cement, proved too fragile in the green condition to allow density measurements, and a number of the wafers fractured during sintering. A second series of wafers was produced, duplicating the first, except that the first two were eliminated and the sintering cycle included a controlled one-hour traverse through the 500 to 900°F range at a constant heating rate. This slow heating through the temperature range at which the acrylic is volatilized, decreased the number of fractured wafers.

The individual results of the wafer experiments with S1 are given in Table 2, with the wafers of the first and second series denoted by Nos. 1 through 6 and Nos. 7 through 10, respectively.

A triplicate series of six wafers each was made with the three sinter filler metals S2, S3, and S4. The amount of cement in each series varied from 20 to 120 drops, again with sufficient acetone to render the mixture moldable. The sinter cycle consisted of heating to 2065°F with a controlled one-hour traverse through the 400 to 700°F range at a constant heating rate, holding for 1/2-hour at 2065°F , and cooling with a controlled two-hour traverse through the 2065 to 1500°F range at a constant cooling rate. The controlled cooling was intended to decrease wafer cracking caused by stresses from nonuniform cooling.

One sintered S2 wafer cracked, five S3 wafers cracked slightly, and all of the S4 wafers cracked severely. Also, the cohesive strength of the sintered S4 wafers was poor and they crumbled easily.

One pertinent observation from the data of Table 2 is that the ratio of cement or acetone to sinter filler metal has little effect on the green or sintered wafer density or on the resulting porosity in the sintered wafer. This indicates that sintered material of rather uniform porosity can be produced over a wide range of added cement and acetone; i.e., the sinter porosity is independent of the amount of cement, within the range of 0.1 to 0.9 w/o of acrylic polymer.

The results with all four sinter filler metals are summarized in Table 3, where the w/o of acrylic polymers and the specific gravities of the green and sintered wafers are averages of the values given in Table 2, except that wafers No. 1 and 2 have been omitted. From these average values, the volume change and porosity were calculated.

TABLE 2
RESULTS OF SINTERING EXPERIMENTS WITH WAFERS

Wafer No.	Sinter Filler Metal		Cement Drops	Acrylic Polymer w/o	Specific Gravity		Volume Change %	Calculated Porosity of Sintered Wafer v/o
	Type	Wt., g			Green	Sintered		
1	S1	7.14	10	0.1	-	5.06	-	38
2	S1	8.00	20	0.2	-	5.12	-	38
3	S1	8.01	30	0.3	4.88	5.26	-7.5	36
4	S1	7.71	40	0.4	4.81	5.10	-6.1	38
5	S1	8.46	50	0.5	4.71	5.15	-9.0	38
6	S1	8.29	85	0.9	4.74	5.19	-9.5	37
7	S1	8.25	30	0.3	4.95	5.36	-7.9	35
8	S1	8.64	40	0.4	4.93	5.36	-8.4	35
9	S1	8.06	50	0.5	4.82	5.38	-10.9	35
10	S1	8.33	85	0.9	4.90	5.36	-9.4	35
11	S2	10.00	20	0.2	5.49	5.49	-0.2	39
12	S2	9.98	40	0.3	5.53	5.40	+2.1	40
13	S2	9.97	60	0.5	5.56	5.61	-1.4	37
14	S2	9.99	80	0.6	5.50	5.53	-1.1	38
15	S2	10.06	100	0.8	5.56	5.57	-1.0	38
16	S2	9.99	120	0.9	5.70	5.67	-0.4	37
17	S3	9.95	20	0.2	5.83	5.79	+0.5	35
18	S3	9.94	40	0.3	5.90	5.99	-1.8	33
19	S3	9.99	60	0.5	5.89	5.97	-1.8	33
20	S3	9.99	80	0.6	5.93	6.02	-2.1	33
21	S3	9.99	100	0.8	5.87	5.98	-2.6	33
22	S3	9.96	120	0.9	5.83	5.87	-1.6	34
23	S4	10.01	20	0.2	5.18	5.12	+1.0	37
24	S4	10.00	40	0.3	5.20	5.21	-0.5	36
25	S4	10.00	60	0.5	5.13	5.11	-0.1	37
26	S4	10.00	80	0.6	5.27	5.30	-1.2	35
27	S4	10.00	100	0.8	5.27	5.27	-0.8	35
28	S4	10.00	120	0.9	5.14	5.02	+1.5	38

TABLE 3
SUMMARY OF SINTERING EXPERIMENTS WITH WAFERS

Filler Metal Type	Acrylic Polymer w/o	Specific Gravity		Volume Change %	Calculated Porosity of Sintered Wafer %
		Green	Sintered		
S1	0.5	4.84	5.27	-8.6	36
S2	0.6	5.56	5.54	-0.2	38
S3	0.6	5.88	5.94	-1.6	34
S4	0.6	5.20	5.17	0	37

The volume change from the green to the sintered condition was appreciable only for sinter filler metal S1; with the remaining sinter filler metals experiencing very small changes. The average porosity of the sintered wafers was about the same for all four sinter filler metals.

3.2 BRAZING OF WAFERS

3.2.1 Sinter Filler Metal S1

Each of the wafers No. 7 through No. 10 of Table 2 was separated along a diameter to produce two sets of four half-wafer specimens. Varying amounts of B1 brazing filler metal paste were applied to the top of the specimens to produce duplicate sets. One set was brazed for 30 minutes at 2065°F and the other for 2 hours at 2190°F. The results are presented in Table 4. The porosity of the brazed specimens is based on the assumption that the true volume of the brazed wafer was equal to the sum of the S1 and the B1 volumes. The high content of low melting point brazing filler metal in specimens 7 and 8 of Table 4 caused the melting point of the resulting alloy to be less than the brazing temperature of 2190°F. These specimens were fused completely as indicated by their external form. The external form of specimen 4 indicated that it had been near its melting point during brazing, and a portion of this specimen did, in fact, melt completely when exposed later to 2065°F for 2 hours.

It is evident from Table 4 that as the weight ratio of B1 and S1 increases, the volume shrinkage from the sintered to the brazed condition decreases, until at a ratio greater than approximately 0.50, there is a volume increase. A ratio of 0.50, where no significant volume change takes place, corresponds to a B1 weight equal to 33% of the weight of the brazed wafer. This also corresponds to a B1 weight equal to 33 v/o for the B1 which is close to the calculated porosity volume percent of the sintered filler metal.

TABLE 4
RESULTS OF BRAZING EXPERIMENTS WITH WAFERS

Specimen No.	Wt _{B1} /Wt _{S1}	Specific Gravity		Volume Change %	Calculated Porosity of Braze Specimen v/o
		Sintered	Braze		
<u>Brazed at 2065^oF for 30 minutes</u>					
1	0.25	5.36	8.00	-16.2	3.0
2	0.30	5.36	7.99	-12.8	3.0
3	0.45	5.38	8.04	- 3.0	2.5
4	0.65	5.36	8.09	+ 9.3	1.9
<u>Brazed at 2190^oF for 2 hours</u>					
5	0.25	5.36	8.13	-17.6	1.4
6	0.30	5.36	8.18	-14.8	0.7
7	0.45	5.38	-	-	-
8	0.65	5.36	-	-	-

A conclusion to be made from the foregoing observations is that the optimum amount of brazing filler metal is equal to the porosity volume of the sintered filler metal. Lesser amounts will result in a volume shrinkage and excessive amounts will cause fusion of the sinter filler metal if the brazing time is too long or the brazing temperature is too high.

Specimens 1 through 6 of Table 4 were sectioned on a radius for metallographic examination. As may be seen in photomicrographs taken from specimen 2 (Figure 2), which had the highest calculated porosity volume percent and from specimen 6 (Figure 3), which had the lowest, the difference in observed porosity extent was less than for calculated porosity. No satisfactory explanation of this discrepancy, or for the appearance of greater porosity in the photomicrographs (Figures 2 and 3) than the calculated values in Table 4, has been found. However, a partial explanation may be experimental errors in density measurements and in visual estimation of pore frequency and size on a single metallographic section. There was also no detectable difference in the microstructures of specimens 1 through 6.

The largest individual single-phase particles of the braze microstructure, clearly outlined in Figure 3, are about 7 mils in diameter. This is much larger than the largest particles of the sinter filler metal S1, which was about 2 mils. Also, the volume of the phases at the interstices of the single-phase particles (hereinafter referred to as the interstitial phase) is much less than the 35% porosity volume of the sintered wafer. Evidently, the sinter filler metal particles have grown during brazing, while consuming a portion of the brazing filler metal.

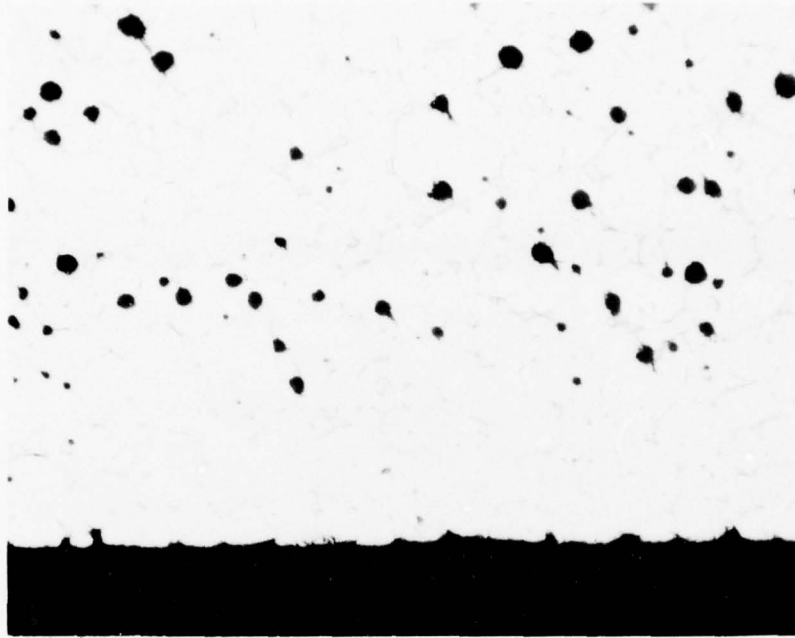

50X

Figure 3. Brazed S1 Microstructure with Lowest Calculated Porosity

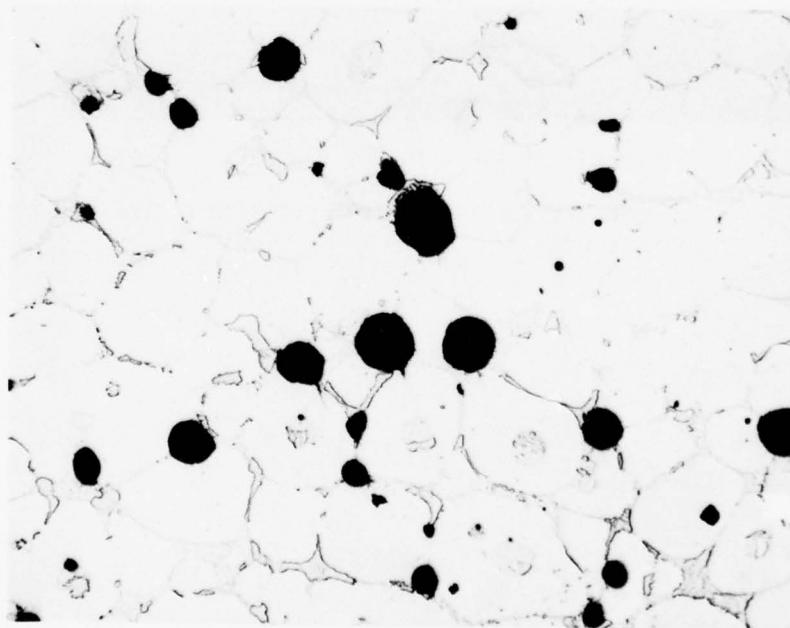

100X

Figure 4. Brazed Specimen Showing Relationship of Porosity and Interstitial Phase

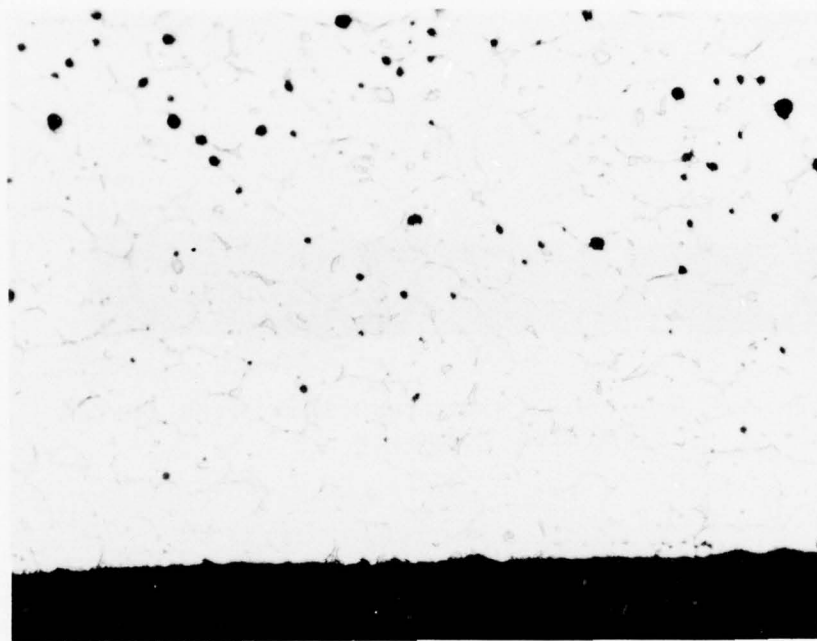

50X

Figure 5. Brazed S1 Microstructure After Diffusion Treatment

A view of specimen 6 at higher magnification is presented in Figure 4. This porosity is typical for specimens 1 through 6. The nearly circular cross section of the pores is highly suggestive of the spherical cavities characteristic of gas porosity. It is also evident that almost every void is either surrounded by, or at least somewhere in contact with the interstitial phase. The porosity is, therefore, not the result of incomplete filling of the sinter filler metal interstices, but is probably caused by the entrapment of gas evolved while the interstitial phase is in the liquid state or during solidification.

Since specimens 5 and 6, brazed at higher temperature and longer time, appeared to have about the same degree of porosity, in general, as specimens 1 and 2 when metallographically examined, it may be concluded that an increase of brazing temperature from 2065 to 2190°F and time from 30 minutes to 2 hours has no appreciable effect on the incidence of porosity.

A portion of each of the brazed specimens 1 through 4 of Table 4 were diffusion treated in vacuum at 2065°F for two hours. An examination of those specimens which did not show external evidence of melting, specimens 1 through 3, indicated no apparent change in the microstructure of the sinter filler metal or the interstitial phase. However, the change in the porosity distribution was highly significant. The porosity of the brazed specimens, both before and after diffusion treatment, was randomly distributed except for a narrow band along the bottom (with reference to position during brazing), which was almost denuded of porosity. This band for specimen 2 may be seen in Figure 2 for the as-brazed condition and in Figure 5 for the diffusion treated condition. The width of the low porosity band had doubled as a result of diffusion treatment. This is further evidence in support of the theory of a gaseous phase being the cause of the porosity, as will be explained later.

An examination of the microstructure of specimen 4 from Table 4, which had completely melted as a result of the diffusion treatment, also revealed the presence of the excessive porosity, typical for sinter filler metal S1.

Another effect of the diffusion treatment is a displacement of some pores away from contact with the interstitial phase, as is to be seen from Figure 5, where more pores are completely surrounded by the sinter filler metal particles than is the case with specimens which had not been diffusion treated.

A possible sequence of events, which could explain the porosity behavior follows: (a) gas is formed during the filling of the sinter filler metal interstices, (b) the gas is to some extent taken into solution in the liquid phase, (c) a lower gas solubility in the solid phase causes gas evolution during solidification, (d) the resulting gas bubbles migrate slowly to the upper

surface, due to the influence of gravity forces, through narrow intricate interstitial passages filled with viscous, partially solidified liquid, (e) the upward migration denudes the lower portion of the specimen of gas bubbles, but before the gas bubbles have time to escape from the upper portion, they are entrapped by the completion of solidification to form pores, (f) upon re-heating to the diffusion treatment temperature, the liquid phase redissolves the gas contained in the pores, (g) slow solidification during the diffusion treatment results in further upward migration of small gas bubbles and an increase in the thickness of the denuded lower portion, (h) the process is completed by the final entrapment of gas bubbles in the upper portion of the specimen upon completion of sinter filler metal and brazing filler metal is such that diffusion treatment causes complete melting, the gas in the pores is taken into solution, and then rejected as pores upon solidification.

3.2.2 Sinter Filler Metals S2, S3, and S4

Three pieces of each sintered wafer Nos. 11 through 28 of Table 2 were selected for brazing. The size of each piece was approximately one quarter of the sintered wafer, except for S4, where the severely cracked wafers yielded only fragments considerably smaller than this.

A set of three brazed specimens was produced from each of the sintered wafers by placing brazing filler metal B1 on top of the three selected pieces in a ratio of brazing filler metal volume to porosity volume (V_B/V_P) of 0.8, 1.0, and 1.2. Therefore, 18 brazed specimens were produced from each of the three sinter filler metals for a total of 54 specimens. Brazing was accomplished at 2065°F for two hours, followed by cooling at a constant rate for two hours from the brazing temperature to 1800°F. The small size of the brazed specimens and the lack of fill in some prevented accurate measurements of the specific gravity. Therefore, the volume change and porosity could not be calculated.

The brazed specimens were sectioned for metallographic examination. Most of the specimens with S2 sinter filler metal contained areas, up to about one half of the examined cross section area in size and located near the center, of sinter unfilled by the brazing filler metal. Two specimens, one at a V_B/V_P ratio of 1.0 and one at 1.2, were completely filled. Otherwise, there appeared to be no correlation between the amount of brazing filler metal and the lack of fill.

Figures 6a and 6b are typical views of the brazed microstructure with S2 sinter filler metal at locations of complete fill. It appears that the microstructure consists of two-phase spherical nodules uniformly distributed in a single-phase matrix. The size of the largest nodules is about equal to the largest particles of the sinter filler metal.

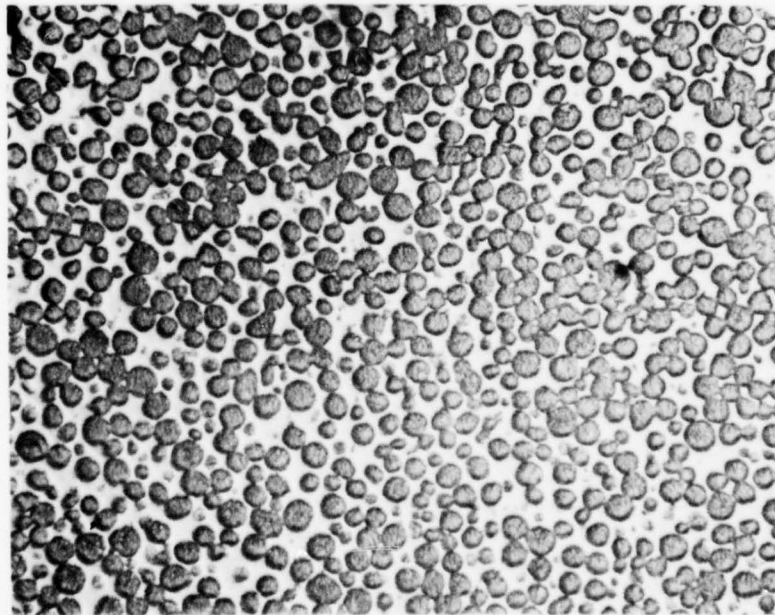

a. Kallings Etch 50X

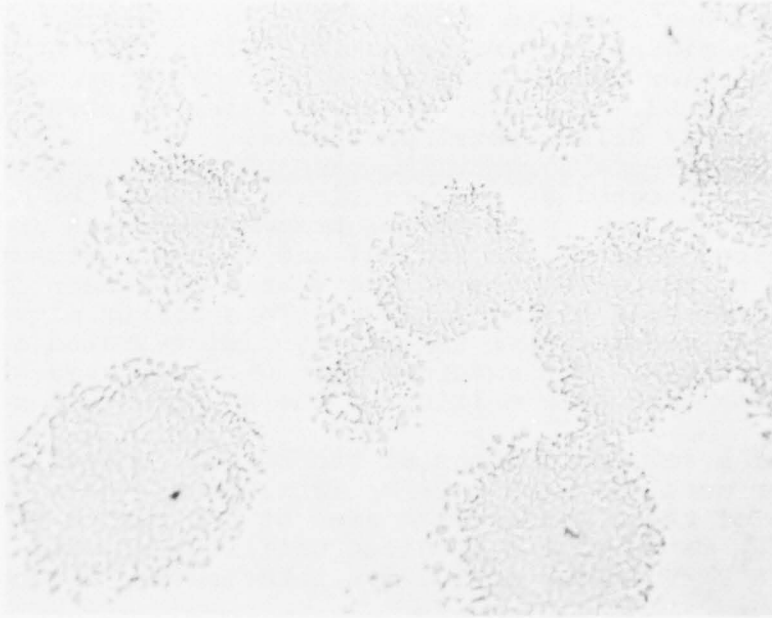

b. Kallings Etch 500X

Figure 6. Brazed S2 Microstructure

The brazed specimens with sinter filler metal S3 all exhibited complete fill by the brazing filler metal, except for a few small areas of little significance. The typical microstructure at the top of the brazed specimens is shown in Figure 7a and at the upper half of 7b. This microstructure is quite similar to that of S2, except for the smaller nodule size and a bit more dispersion within the nodules for the S3. The size of the nodules is about the same as that of the sinter filler metal particles.

Figure 7b is located at the transition between the nodular microstructure of the top part of the brazed specimens (represented by the upper half of the figure) and the microstructure of the bottom half to three-fourths of the brazed specimens (represented by the lower half of the figure). This latter microstructure indicates that the nodules have completely disintegrated into fine scattered precipitates. The external form of the brazed specimens gave no indication that bulk melting of the specimen had occurred.

Except for a few small areas at the bottom, brazed specimens of sinter filler metal S4 with a V_B/V_P ratio of 1.2 were filled. About one third of the cross section area at the bottom of specimens with a V_B/V_P ratio of 0.8 remained unfilled, and the fill of specimens with a V_B/V_P ratio of 1.0 was intermediate between that of 1.2 and 0.8.

The microstructure of the S4 brazed specimens, shown in Figures 8a and 8b, is similar to that of sinter filler metal S2, except for much greater dispersion of the nodules. The size of the nodules is about the same as that of the sinter filler metal particles.

3.3 POROSITY INVESTIGATION

Experiments were carried out in an attempt to determine the source or cause of the excessive porosity found in brazed wafers containing S1 sinter filler metal. These experiments also included those designed to discover a technique to reduce the porosity incidence to a lower level.

Several possible sources of a gas which could cause porosity have been suggested. These are the sublimation of a solid such as B_2O_3 or Cr, the decomposition of a compound such as Cr_2O_3 or SiO_2 , the evaporation of some element or compound, a reaction product, or a residual gaseous element in either the S1 or the B1. Porosity caused by some of these possible sources could be affected by heat treatment prior to brazing or by the level of vacuum during brazing.

The entrapment of porosity could be due to a very rapid flow of brazing filler metal on surfaces of the wafer, which could hinder the escape of gas formed during subsequent penetration of brazing filler metal into the interior of the wafer.

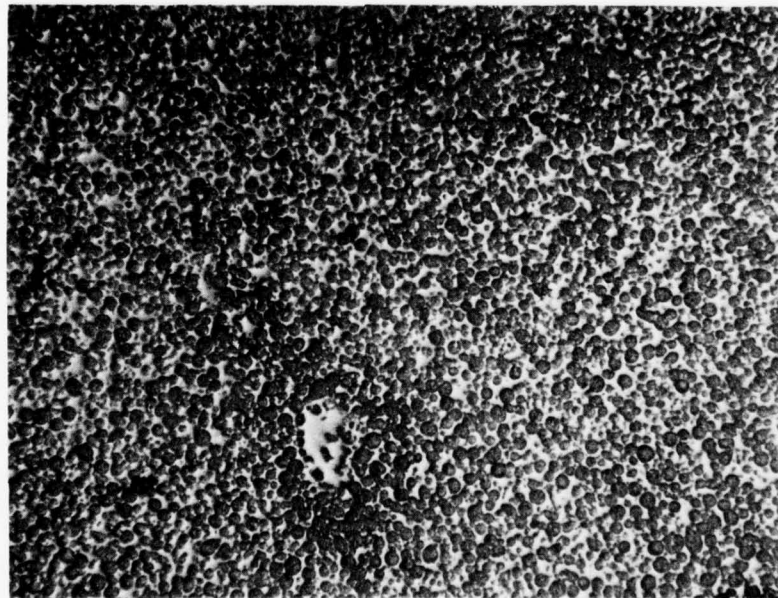

a. Kallings Etch 50X

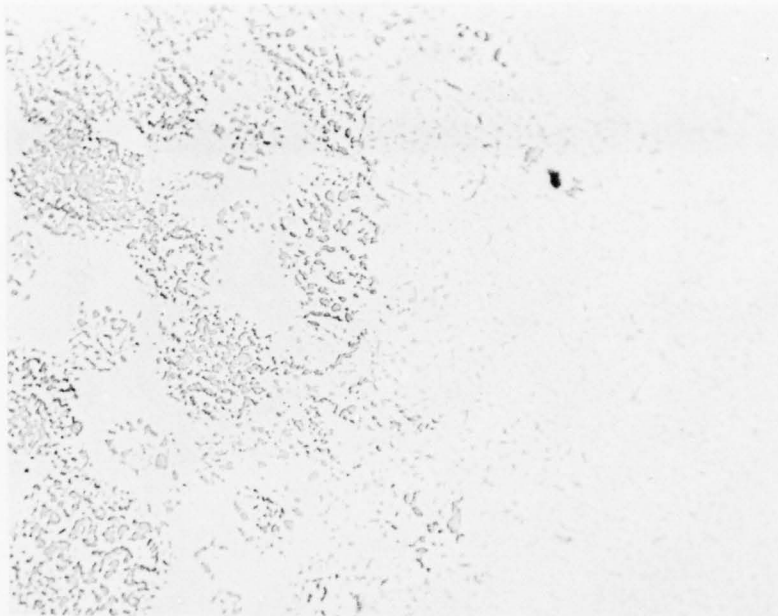

b. Kallings Etch 500X

Figure 7. Brazed S3 Microstructure

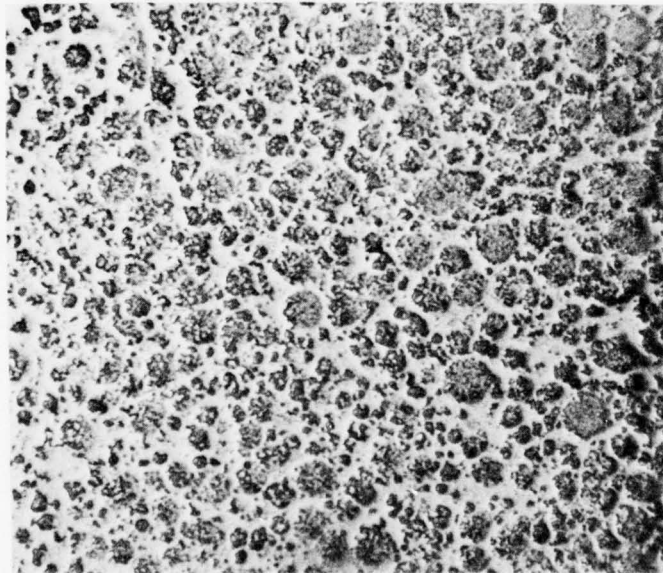

a. Kallings Etch 50X

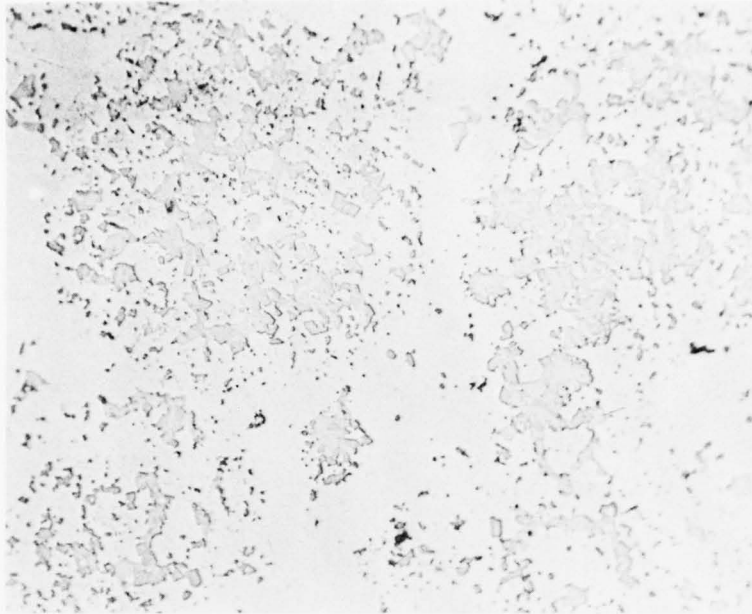

b. Kallings Etch 500X

Figure 8. Brazed S4 Microstructure

The possibility that hydrogen could be the source of porosity was examined by chemical analysis of two sinter filler metals. The hydrogen content of the as-received S1 and S2 sinter filler metals was 42 and 19 ppm, respectively. After subjecting the sinter filler metals to a sintering cycle and a brazing cycle (with no brazing filler metal) the hydrogen content increased to 114 ppm in S1 and 130 ppm in S2. The difference in hydrogen content of the as-received sinter filler metals could not account for the much greater porosity with S1 sinter filler metal. In addition, the hydrogen content of the sinter filler metals, in the condition in which they are brazed, was slightly greater for the sinter filler metal with the lesser porosity.

A group of 24 wafers was brazed to determine the effect of vacuum pressure, presintering, and control of surface flow on porosity. The weight ratio of B1 to S1 was 0.2. Half of the specimens were brazed in a vacuum of 1×10^{-2} Torr and half at 1×10^{-5} Torr. A low impurity level in the lower vacuum atmosphere was ensured by first evacuating to 1×10^{-5} Torr with a diffusion pump, backfilling with argon, and finally evacuating to 1×10^{-2} Torr with a mechanical vacuum pump. Half of the specimens were brazed after sintering at 2065°F for 1/2 hour and half were brazed in the green condition. Brazing filler metal flow was prevented on selected surfaces by the application of a thin coating of stopoff before brazing.

The brazing conditions and the resulting specific gravity of the brazed wafers is presented in Table 5. Top and bottom, in the column which indicates the location of stopoff application, refers to the position of the wafer during brazing. A slurry of the B1 brazing filler metal with cement and solvent was cast on top of each wafer in either the green or sintered condition and, after drying, stopoff was applied. Wafers, which were to be brazed with stopoff on either the top or bottom, were coated with stopoff on the face opposite the B1. Placement of the wafer in the brazing furnace, either inverted or not, determined whether the wafer was brazed with B1 on the top or on the bottom. The wafers were brazed at 2065°F for 30 minutes.

Although the amount of B1 added was less than the porosity volume of a sintered wafer, a comparison of brazed specific gravities with those of Table 3 indicates that this brazing filler metal deficiency did not result in decreased densities.

An examination of the average specific gravity values in Table 5 reveals no significant difference in the wafer porosity content between those brazed in high or low vacuum, between those with and without stopoff-coated surfaces, or between those in the green or sintered condition before brazing.

TABLE 5
RESULTS OF WAFER POROSITY EXPERIMENTS

Wafer No.	Vacuum, Torr	Pre- sintered	Stopoff Application	Specific Gravity		
				Single	Average	
1	10^{-5}	Yes	top	8.13		
2			bottom	8.13		
3			side	8.04		
4			top and side	8.14		
5			bottom and side	8.10		
6			none	8.06		
7	10^{-2}	No	top	8.06		
8			bottom	8.13		
9			side	8.00		
10			top and side	8.05		
11			bottom and side	8.00		
12			none	8.06		
13			Yes	top	8.07	
14			bottom	8.05		
15			side	8.05		
16			top and side	8.00		
17			bottom and side	8.13		
18			none	8.15		
19	No	No	top	8.00		
20			bottom	8.01		
21			side	8.04		
22			top and side	8.09		
23			bottom and side	8.04		
24			none	8.05		
1 - 12	10^{-5}	-	-		8.07	
13 - 24	10^{-2}	-	-		8.05	
1 - 6 and 13 - 18	-	Yes	-		8.09	
7 - 12 and 19 - 24	-	No	-		8.04	
1 - 5, 7-11, 13 - 17, and 19 - 23	-	-	Yes		8.06	
6, 12, 18, and 24	-	-	None		8.08	

A second series of 24 wafers of various compositions made from mixtures of elemental powders was brazed. A small amount of brazing filler metal was also included in some of the mixtures to determine its effect. Carbon was added to some of the mixtures via a suspension of carbon black in the cement used to make the green wafers.

Twelve of the wafers were brazed after sintering and twelve in the green condition. The sinter cycle included a constant heating rate from 500 to 900°F, a one hour hold at 1850°F, a one-half hour hold at 2065°F, and a furnace cool.

The wafers were brazed with B2 brazing filler metal in the form of a slurry made with cement containing a suspension of carbon black, resulting in a carbon content of 0.1 w/o in the B2. The amount of B2 was equal to 35% of the weight of the wafer. Brazing was accomplished at 1850°F for 3 hours, followed by 2190°F for 2 hours, and a furnace cool. The purpose of the 3 hour hold at 1850°F was to allow carbon reduction of compounds such as Cr_2O_3 to take place below the brazing temperature so that gaseous products of this reaction could not form porosity during brazing.

The composition of the wafers and the specific gravities of the brazed specimens are given in Table 6. Since the true density of most of the brazed specimens is not known, the porosity volume cannot be calculated. However, a comparison of the average specific gravities indicates considerably less porosity in specimens brazed after sintering than those brazed in the green condition.

Only the specimens brazed in the sintered condition (Column A) were subjected to metallographic examination. This examination revealed that the amount of gas porosity in specimens 9A and 12A was about the same as previously observed in other brazed wafers containing S1 sinter filler metal. The remaining specimens, containing no S1 exhibited approximately the same amount of gas porosity, but at a lower level than specimens 9A and 12A. Figure 9 shows the microstructure of specimen 11A, which is typical with regard to gas porosity for specimens containing no S1.

An additional observation was a greater tendency for specimens which were sintered with additions of brazing filler metal (10A through 12A) to form porosity indicative of incomplete fill, as may be seen in the upper right corner of Figure 9.

A third group of four S1 wafers was brazed at 2190°F for one-half hour. Two of these were brazed after sintering at 2065°F for one-half hour in a vacuum of approximately 1×10^{-2} Torr and two were brazed in the green condition. One pair, consisting of a pre-sintered and a green wafer, was brazed with B2 brazing filler metal and the remaining like pair was brazed with B3 brazing filler metal. In each case, the amount of brazing filler metal was equal to 35 w/o of the sinter filler metal.

TABLE 6
RESULTS OF WAFER POROSITY EXPERIMENTS

Spec. No.	Composition of Wafer, w/o ^a						Specific Gravity of Brazed Wafer	
							Sintered Column A	Green Column B
	C	Cr	Si	B1	B2	Bal.	Single Ave. ^b	Single Ave. ^b
1						Ni	8.73	8.51
2	0.1					Ni	8.74	8.46
3		20				Ni	8.52	8.18
4	0.1	20				Ni	8.66	8.18
5			2			Ni	8.70	8.35
6	0.1		2			Ni	8.61	8.26
7		20	2			Ni	-	8.07
8	0.1	20	2			Ni	8.62	8.07
9	0.1					Sl	8.32	8.03
10	0.1	20			10	Ni	8.63	8.29
11	0.1	20		10		Ni	8.59	8.32
12	0.1			10		Sl	8.23	8.11
							8.58	8.25

a. Composition of wafer prior to brazing.

b. Average does not include Specimen No. 7.

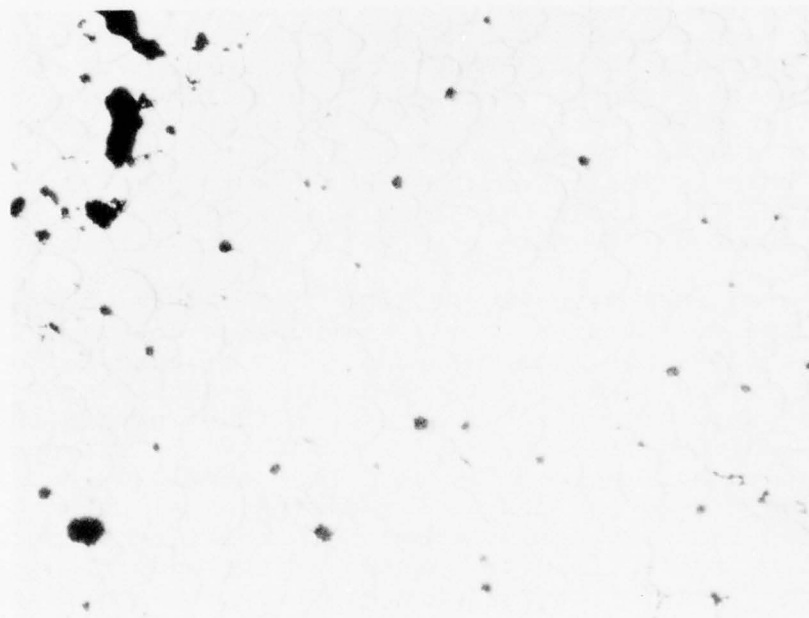

Kallings Etch 50X
Figure 9. Brazed Microstructure of
Specimen Containing No
1 Sinter Filler Metal

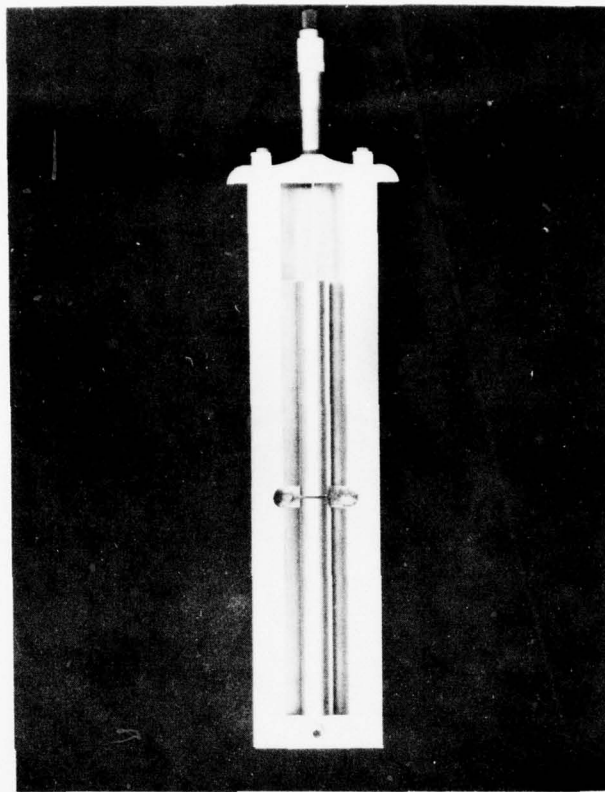

Figure 10. Assembly Fixture

A visual examination of metallographic cross sections of the four brazed specimens revealed no appreciable difference in the porosity amount, which was about the same as previously observed in brazed wafers containing S1 sinter filler metal. Neither the B2, with only boron as a melting point depressant; or the B3, with only silicon as a melting point depressant, served to suppress the formation of gas porosity in the brazed specimens.

SECTION IV

BRAZING OF TENSILE SPECIMENS

This section describes the experimental work performed in the development of a sintering and brazing method for the production of sound brazed joints in the base metal rod, suitable for mechanical testing. All sintering and brazing was done in a vacuum of approximately 1×10^{-5} Torr. The faying surface was either as produced by an abrasive cutoff wheel or surface ground. Brazed joints of equal quality were obtained with either method of faying surface preparation. Specimens were degreased with acetone before sintering and brazing.

4.1 SPECIMEN IN HORIZONTAL POSITION

The first experiments were made with the longitudinal axis of the specimen in the horizontal position for both sintering and brazing.

A photograph of the fixture used for the assembly of joints prior to sintering, with a specimen in place, is shown in Figure 10. After applying an excess of a paste of sinter filler metal and acrylic cement with acetone solvent to one end of the first rod and placing it in the V-groove, the second rod was pressed against the first until the desired joint clearance was obtained. The joint clearance was measured with the attached depth micrometer. The excess sinter filler metal, extruded from the joint, was scraped from the periphery of the joint. There is a lower limit to the joint clearance, below which it was not possible to compress the filler metal paste. This limit was about 6 mils for the S1 sinter filler metal and about 8 - 10 mils for the S2 sinter filler metal.

After drying at room temperature, the joints were carefully placed in a V-groove of a fixture similar in design and size to that used for joint assembly, and sintered. Visual examination revealed that the joints sometimes cracked during sintering. Various techniques were attempted in an effort to eliminate this cracking. These included changing the material of the sintering fixture from molybdenum to austenitic stainless steel, using lower heating and cooling rates, and the use of differential thermal expansion resulting from the application of an axial compressive load on the joint by means of bolts mounted at the ends of a molybdenum fixture. None of these techniques resulted in an acceptable improvement.

Uncracked sintered joints were brazed in the sintering fixture with brazing filler metal paste applied to the upper side of the joint and stopoff between the specimen and the V-groove of the fixture. The results were questionable because of cracks and incomplete fill, as determined by visual and metallographic examination.

4.2 SPECIMEN IN VERTICAL POSITION

Specimens were next sintered and brazed in the vertical position, with either external or internal feeding of the brazing filler metal. A cross-sectional sketch of the braze joint with external feeder ring is illustrated in Figure 11. A photograph of the specimen after brazing is shown in Figure 12. Both of these figures illustrate the specimen in the sintering and brazing position. This type of braze joint was adopted for the production of specimens for tensile testing.

Satisfactory joints were also produced in the vertical position with internal feeding of the brazing filler metal. The upper specimen half had a 3/16-inch diameter through hole drilled on its longitudinal axis, in which the brazing filler metal was placed. No feeder ring was attached to the specimen.

The brazing procedure for the external feed specimen consisted of the following steps: (a) assemble with sinter filler metal as described above in para. 4.1, (b) sinter in the vertical position with the time-temperature cycle shown in Figure 13, (c) place an excess of dry brazing filler metal in the bevel of the feeder ring, and (d) braze in the vertical position with the time-temperature cycle shown in Figure 13. The feeder ring was attached either before sintering or after sintering, as will be explained later.

The outside diameter of the feeder ring was 3/4-inches for joints with smaller clearances and was made of Hastelloy N. The ring for larger joint clearances was 7/8-inches and Inconel 600 alloy. The amount of brazing filler metal placed in the feeder ring was a minimum of three times that needed to fill the porosity of the sinter filler metal.

The controlled slow heating rate from 400 to 700°F for the sinter cycle, shown in Figure 13, was intended to avoid possible cracking of the sinter material, due to too rapid gas evolution from the cement. The controlled slow cooling rates from 2065 to 1500°F for the sinter cycle and from 2065 to 1800°F for the braze cycle were for the purpose of avoiding possible cracking due to thermal stresses from rapid cooling through a critical range at high temperature.

The sinter and braze cycles of Figure 13 were not the result of a systematic investigation, but were rather those which evolved during the preliminary experiments with sinter filler metal wafers and the first attempts to braze butt joints in the horizontal position. Therefore, these sinter and braze cycles may not represent the optimum conditions.

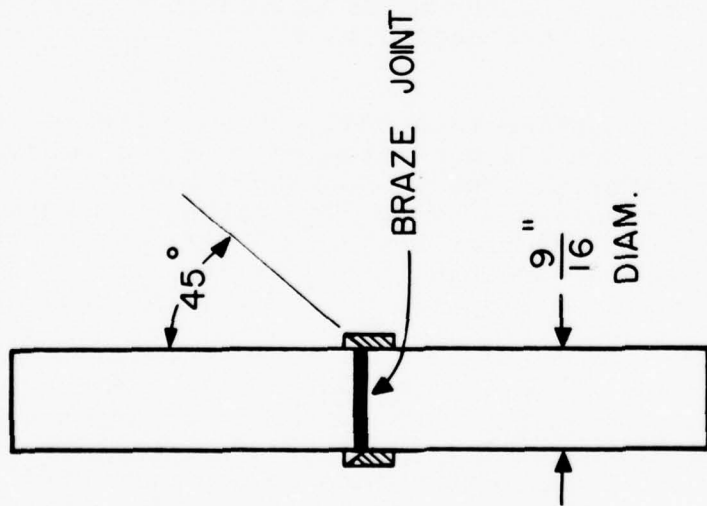

Figure 11. Cross Section of Braze Specimen



Figure 12. Braze Specimen

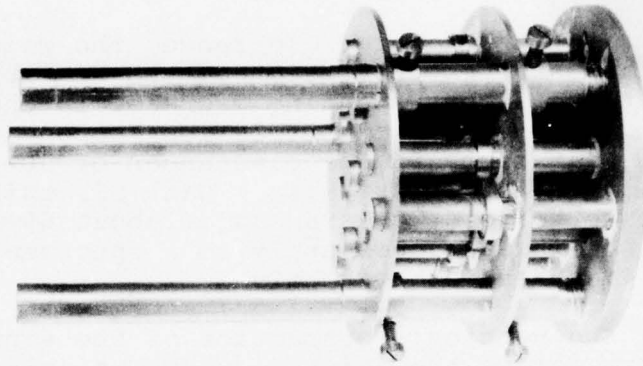

Figure 14. Brazing Fixture

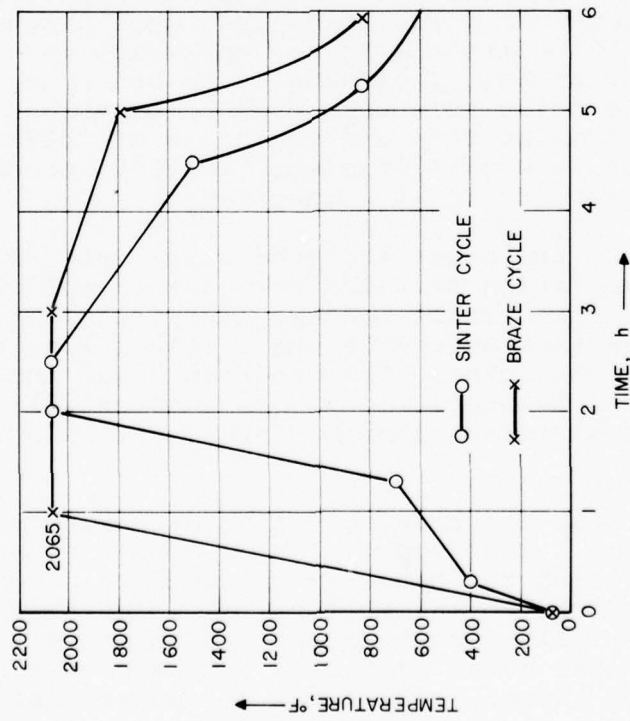

Figure 13. Sinter and Braze Time-Temperature Cycle

The combined length of both specimen halves for the first trials of vertical position sintering was 1-1/2 inches, and these were simply placed upright on the furnace platen for sintering. Specimens of 4 inches combined length were positioned in through holes of a 1/2-inch thick metal plate resting on the furnace platen.

When sintering joints of large clearance, the weight of the upper specimen half caused some extrusion of the sinter filler metal from the joint and a corresponding decrease in the joint clearance. With S1, this vertical contraction (perpendicular to the faying surface) was about 20% for clearances of 20-30 mils, 30% for 40-80 mils, and 40% for 100 mils. With S2, this contraction was negligible up to joint clearances of about 60 mils and about 30% at 75 mils. These values apply to a specimen with a combined length of 4 inches for both halves.

Occasionally, the vertical contraction of the sinter filler metal was not uniform across the joint diameter, causing the upper specimen half to topple over, and in turn damaging adjacent specimens. The fixture shown in Figure 14, with ten specimens in place, was used for sintering of large clearance joints to prevent tipping over of the upper specimen half. The through holes in the two upper plates and the blind holes in the bottom plate were drilled with the alignment and diameter necessary to maintain proper alignment of the brazed specimens. The two upper plates were vertically adjustable for specimens of various lengths and to permit insertion and removal of the specimens. These plates were supported by slip rings, fastened by bolts with pointed ends tightened against the three vertical guide rods. The guide rods were circumferentially grooved to locate the bolts and to prevent slippage of the upper plates in the event of bolt loosening. The two upper plates, the slip rings, and the guide rods were made of molybdenum, the bottom plate of molybdenum alloy TZM, and the bolts of Cb1Zr alloy. The vertical guide rods were of sufficient length to accommodate the sintering of specimens up to 10 inches long.

A few joints with large clearance were sintered with spacers located between the faying surfaces to maintain the clearance during sintering. Three small spacers distributed at 120° around the perimeter, were tack welded to one of the faying surfaces before assembly of the joint. This technique was not adopted as a standard practice, however, because of a potential sinter cracking problem due to shrinkage during sintering with a fixed joint clearance.

After sintering, the brazing filler metal feeder ring was tack welded in place. Some separation of joints at one faying surface occurred during the handling and welding necessary for this operation. If the faying surface, at which this separation occurred, was accessible for the removal with emery paper of adhering sinter filler metal particles, the specimen halves were placed together and brazed. There was no apparent effect of this on the quality of the resulting brazed joints.

The separation of joints after sintering was virtually eliminated by a technique which avoided tack welding of the feeder ring. Three narrow strips of 10-mil nickel foil were resistance spot welded at 120° around the periphery of the lower specimen half at the proper distance below the faying surface. After assembly of the joint, the feeder ring was slipped down over the upper half specimen to rest on the ends of the three nickel strips.

Stopoff was applied to the underside of the feeder ring at its junction with the lower specimen half, to prevent brazing filler metal from flowing down the sides of the specimen. For brazing, specimens were located in through holes of a 1/2-inch thick metal plate resting on the furnace platen.

Joints which were made with no sinter filler metal were brazed in the same manner as those with sinter filler metal, except that the joint clearance was maintained by three small tack welds with Hastelloy W filler metal spaced at about 120° around the perimeter of the joint.

SECTION V

METALLOGRAPHIC EXAMINATION OF BRAZED JOINTS

A representative sample of each furnace run was selected for metallographic examination. About 25 brazed specimens with no sinter filler metal, 30 with S1 sinter filler metal, and 35 with S2 sinter filler metal were examined.

5.1 JOINTS WITH NO SINTER FILLER METAL

A photomicrograph of a joint cross section, which is typical regarding general appearance, porosity, and dissolution of the base metal at the brazing filler metal reservoir (feeder ring), is shown in Figure 15. The joint clearance is 9 mils. This is typical only for joint clearances of about 5 to 20 mils.

At joint clearances of about 20 mils, large voids and associated cracking sometimes formed near the upper faying surface. These defects became more severe as the joint clearance increased. A photomicrograph of this condition in a 23-mil joint is shown in Figure 16.

The braze metal microstructure of joints with a clearance up to approximately 4 mils consisted entirely of a solid solution phase as illustrated in Figure 17 for a 3-mil joint clearance. As the joint clearance increased to 5 or 6 mils, linear intermetallic compounds formed intermittently along the centerline, accompanied by a layer along each faying surface of essentially a solid solution phase. Figure 18 was taken at a location in a 5 mil-joint where these centerline phases were present. In some cases, the centerline consisted of fine, closely spaced, scattered particles.

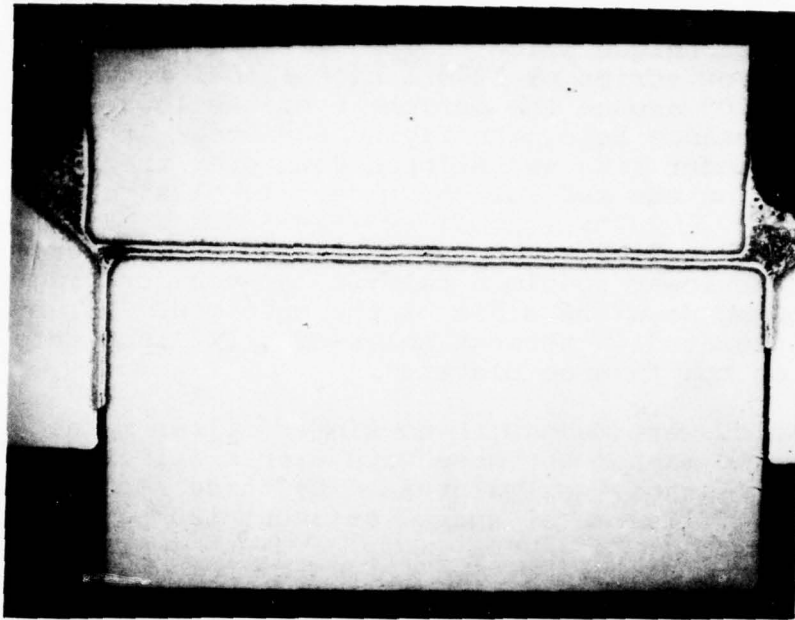

Kallings Etch 7X

Figure 15. Typical Braze Joint with No Sinter Filler Metal for Small Joint Clearance, 9 mil

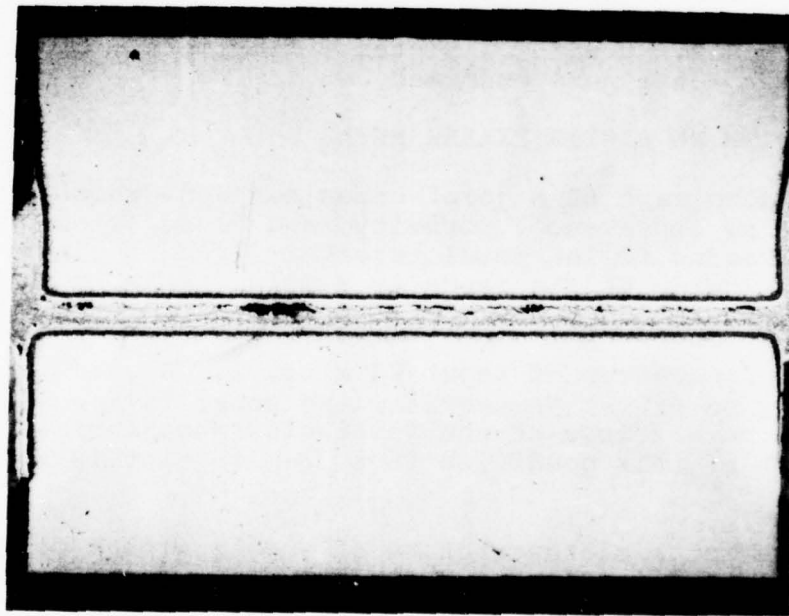

Kallings Etch 7X

Figure 16. Typical Braze Joint with No Sinter Metal for Large Joint Clearance, 23 mil

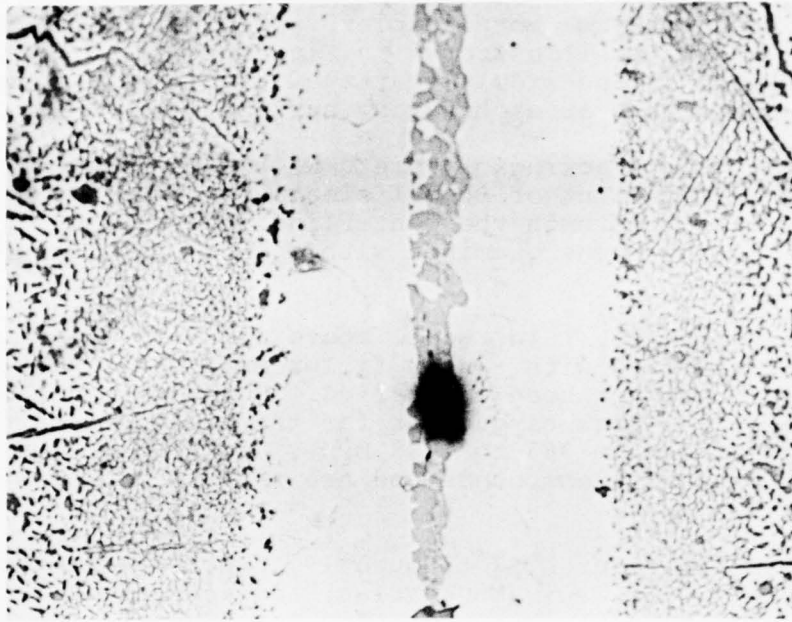

Kallings Etch 400X
 Figure 18. Braze Joint with No
 Sinter Filler Metal
 and 5 mil Clearance

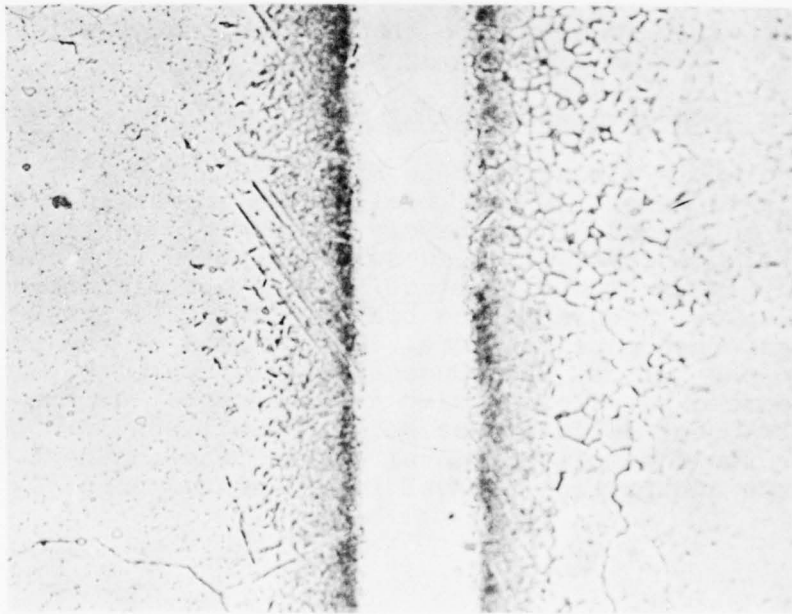

Kallings Etch 200X
 Figure 17. Braze Joint of 3 mil
 Clearance with No Sinter
 Filler Metal

With further increase in joint clearance, the centerline intermetallic compounds became more complex, wider, and were continuous along the joint, as illustrated in Figure 19 for a 9-mil joint. There was also a fine widely scattered precipitate formed in the solid solution phase at each faying surface.

In addition to the cracking of joints with a clearance greater than 20 mils, one brazed joint of 10-mil clearance contained an extensive continuous crack through the centerline intermetallic phases. This was one of nine specimens examined with a joint clearance between 5 and 20 mils.

The centerline phases, referred to above and later in the discussion of joints brazed with sinter filler metals as intermetallic compounds, have not been identified. However, since measurements indicated very high hardnesses for these centerline phases (single readings varied from 383 to 1288 DPH), it is very likely that they are intermetallic compounds and are referred to as such in this report.

As may be seen in Figures 17 through 19, precipitates were formed at grain boundaries, twin boundaries, and intragranularly in the base metal adjacent to the braze metal. The fine grained base metal microstructure, visible in Figure 17 was not associated with the sintering and brazing exposure. The fine grained microstructure was also present in the base metal well removed from the braze joint.

5.2 JOINTS WITH SINTER FILLER METAL

The braze metal microstructure of joints with sinter filler metal differed markedly from those with no sinter filler metal. The linear intermetallic compounds were absent (except where fill was not complete) and the microstructure of joints with larger clearances was virtually identical to that of the brazed wafers except for a narrow zone at each faying surface.

5.2.1 Joints with S1 Sinter Filler Metal

A typical joint is illustrated in Figures 20a and 20b. The joint clearance is 15 mils. Interstitial phases appear in a center zone of the braze metal containing barely discernible particles of sinter filler metal. A layer of solid solution phase is located at both faying surfaces. The difference between the microstructure of brazed wafers; e.g., Figure 3, and brazed joints (Figure 20) may be explained by base metal effects. During flow of the brazing filler metal into the joints, the concentration of melting point depressants is reduced by alloying with the base metal at the faying surface. Subsequent diffusion of boron and silicon into the base metal causes their complete removal from a zone adjacent to each faying surface and partial removal from a center zone.

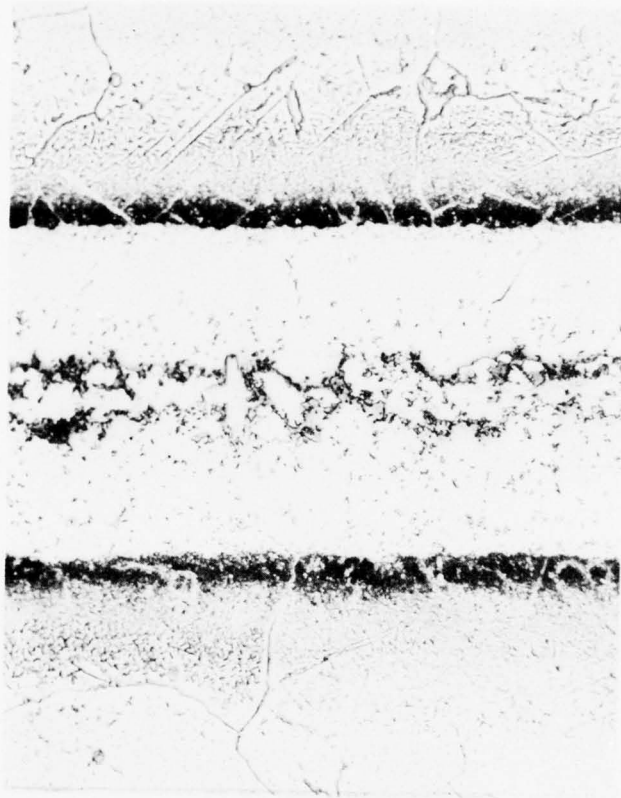

Kallings Etch 200X

Figure 19. Braze Joint of 9 mil
Clearance with No
Sinter Filler Metal

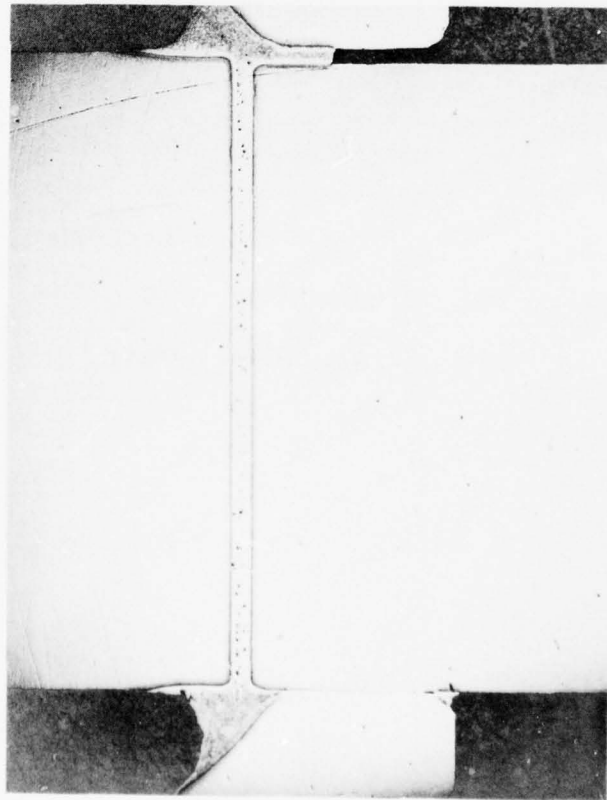

a.

7X

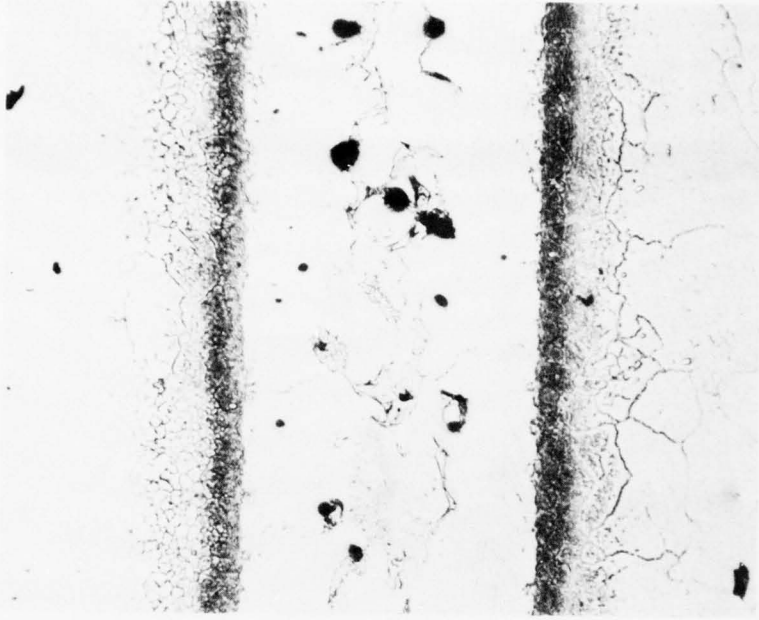

b.

Kallings Etch 100X

Figure 20. Typical Braze Joint with SI Sinter Filler Metal, 15 mil

In most cases, at low joint clearances up to approximately ten mils, the center zone of intermetallic compounds was absent (similar to Figure 17), except that some porosity was present, with a linear distribution at the centerline of the joint.

Some joints with clearances of from 6 to 10 mils contained massive intermetallic compounds in the braze metal at the joint centerline, accompanied by extensive cracking and voids. Figure 21 is an illustration of this condition, which is believed to be caused by incomplete filling with the sinter filler metal. The resulting excess of brazing filler metal caused complete melting of the combined filler metals and the subsequent formation of linear centerline intermetallic compounds upon solidification. This microstructure was very prone to cracking, since cracks occurred in all four brazed joints in which this microstructure was observed.

At large joint clearances, represented by a 46-mil joint in Figures 22a and 22b, the microstructure is similar to joints with smaller clearances (see Figure 20b), except that the incidence of porosity and the width of the center zone containing interstitial phases increases. The individual particles of the sinter filler metal are also more distinct. The porosity concentration in all specimens was lower in the single phase structure at both faying surfaces than in the center zone. Brazed joints made with two different lots of S1 sinter filler metal both contained the excessive porosity shown in Figure 22a.

A limited examination by electron microprobe techniques indicated that the more massive of the interstitial phases seen in Figure 22b is probably a boride.

A specimen (joint clearance 30 mils), which was brazed at a temperature of 2065°F for 1/2 hour plus 2190°F for 2 hours, rather than the 2065°F for 2 hours of the standard braze cycle, did not show a significant change in the braze metal microstructure except that the base metal dissolution, at the periphery of the joint, was somewhat greater.

No significant difference in the base metal microstructure, between the joints brazed with S1 or without sinter filler metal, was observed.

5.2.2 Joints With S2 Sinter Filler Metal

The braze metal microstructure of joints made with S2 sinter filler metal were remarkably similar at all joint clearances greater than 12 mils. Three views of a typical joint are shown in Figures 23a-23c at a joint clearance of 13 mils.

The light area in the braze metal, indicated by an arrow in Figure 23a is the result of a hole left in the sinter filler metal, which was subsequently filled by the brazing filler metal. Occasionally, these holes in the sinter filler metal did not fill during

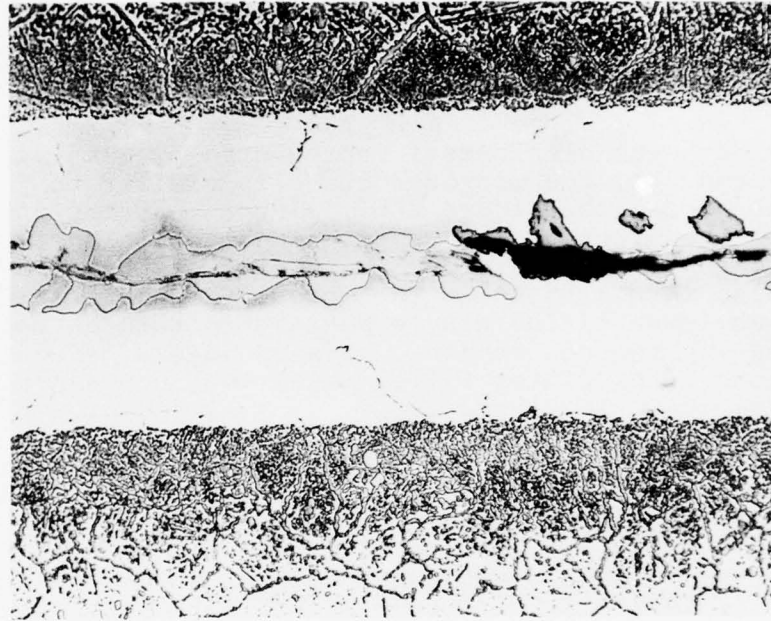

Kallings Etch 200X

Figure 21. Braze Joint of 8 mil Clearance
with S1 Sinter Filler Metal
Containing Cracks and Voids

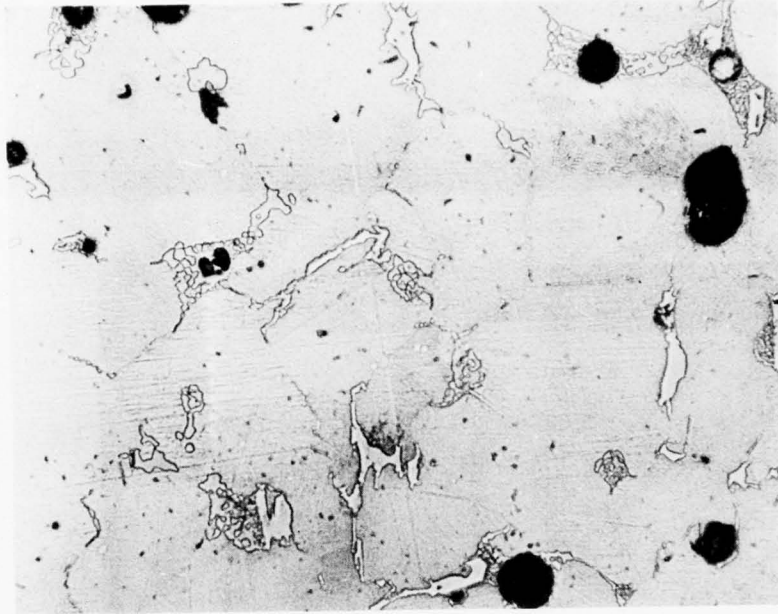

b. Kallings Etch 200X

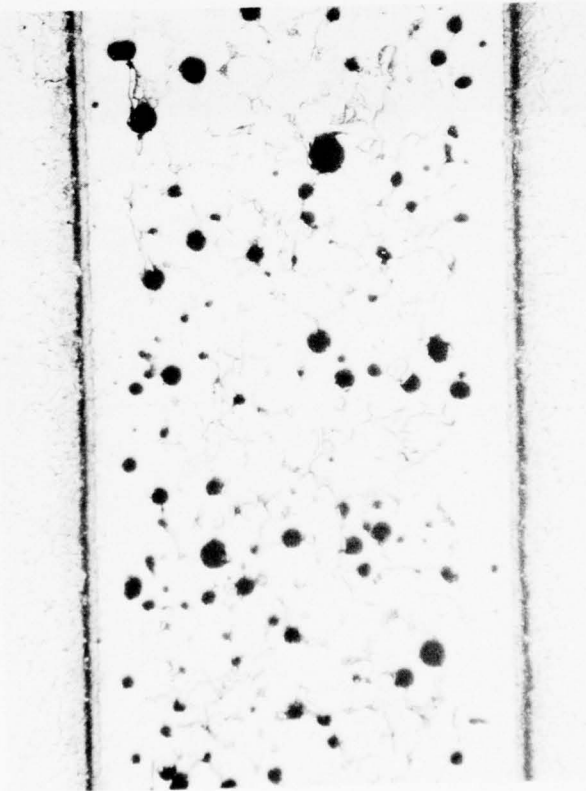

a. Kallings Etch 50X

Figure 22. Braze Joint of 46 mil Clearance with S1 Sinter Filler Metal

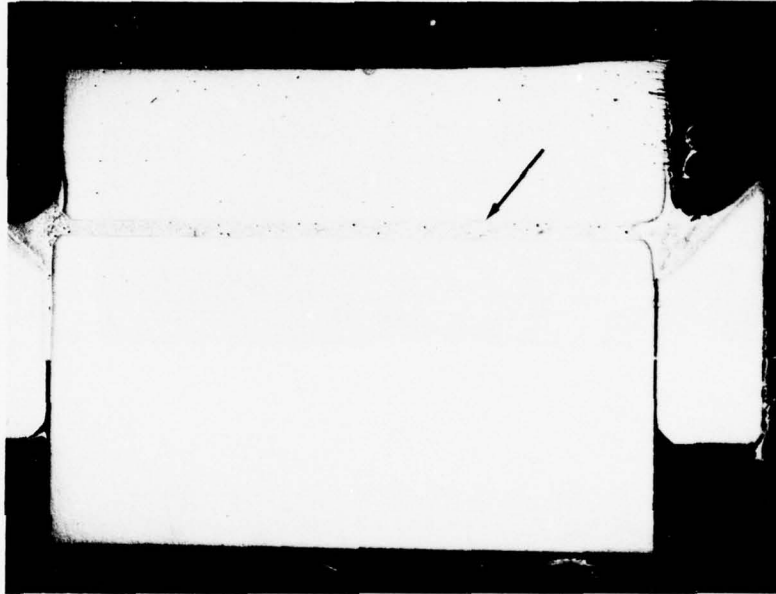

a.

Kallings Etch 7X

Figure 23. Typical Braze Joint with S2 Sinter Filler Metal, 13 mil

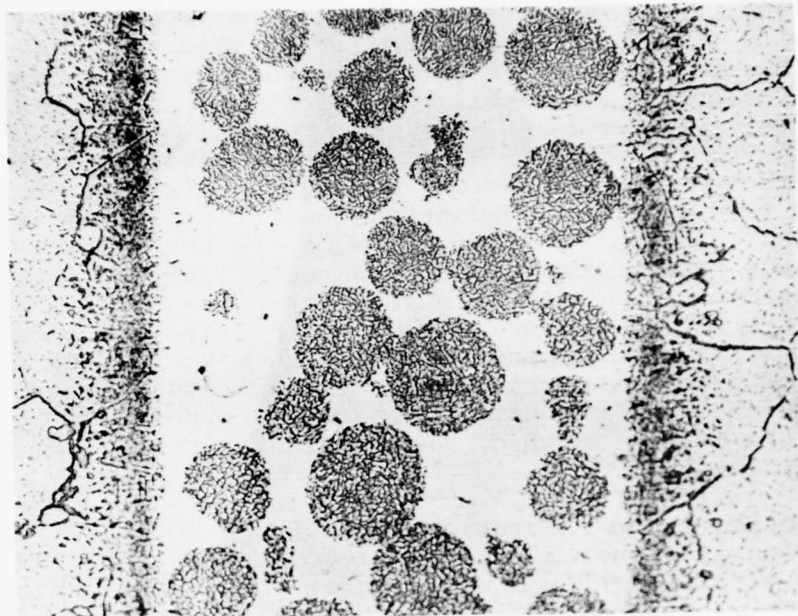

Kallings Etch 200X

c.

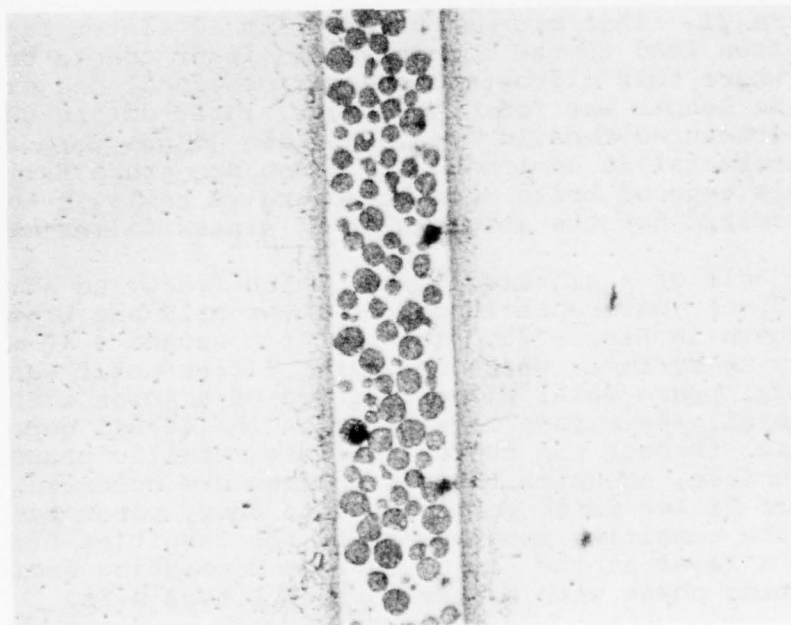

Kallings Etch 50X

b.

Figure 23. Typical Braze Joint with S2 Sinter Filler Metal, 13 mil

brazing, and resulted in pores in the braze joint of a size about equal to the joint clearance, as illustrated in Figure 24. This example is not typical; it represents the most severe porosity which was observed. At joint clearances of 20 mils and greater, only fine porosity with a frequency similar to that of Figure 23a was present, i.e., no large voids were observed, either filled or not filled by brazing filler metal.

As seen in Figures 23b and 23c, the braze metal microstructure consisted of two-phase spherical nodules in a single phase matrix, with no tendency to a concentration of the nodules in any part of the joint. A limited examination of the braze metal microstructure was made by electron microprobe techniques. A preliminary analysis indicated that the matrix phase within the nodules probably is the same as the matrix phase in which the nodules are embedded. Also, the precipitate of the nodule is high in Mo and W and is probably a boride or a boride-carbide. The precipitates are isolated particles of equiaxed and elongated form. The hardness of the nodules and of the matrix in which the nodules are embedded, is 287 and 190 DPH, respectively.

A representative photomicrograph of a braze joint with a large clearance is shown in Figure 25 at 74 mil-joint clearance. The rectangular object at the right end of the braze metal is a shim placed in the joint before brazing to maintain the joint clearance.

At joint clearances up to 12 mils, the braze metal microstructure sometimes consisted of linear intermetallic compounds at the joint centerline, with single-phase solid solution at both sides, similar to Figure 21. This microstructure with S2 sinter filler metal did not often lead to the formation of either cracks or voids. Of five joints where this microstructure was observed, one crack of about 1/8-inch in length was found. However, later during the examination of fractured tensile specimens, two joints were found where linear intermetallic compounds did cause premature failure. The cause of this type of braze microstructure is believed to be the same as described for the joints with S1 sinter filler metal.

The upper half of a sintered joint, which fractured at the lower faying surface, was replaced on the lower half and brazed. The result is shown in Figure 26. The poor fit caused a 10-mil gap at the lower faying surface, where no sinter filler metal was present. The typical braze metal microstructure of a joint with no sinter filler metal, see Figure 19, formed in the 10-mil gap, with extensive cracking through the centerline intermetallic phases. If the faying surface, at which the sinter fracture occurred, was cleaned of sinter filler metal particles with emery paper before replacement of the remaining specimen half, the resulting brazed joint contained a layer at the faying surface consisting entirely of a solid solution phase with a thickness of 1 to 2 mils.

There was no detectable difference in the microstructure of the base metal between joints brazed with either S1, S2, or without sinter filler metal.

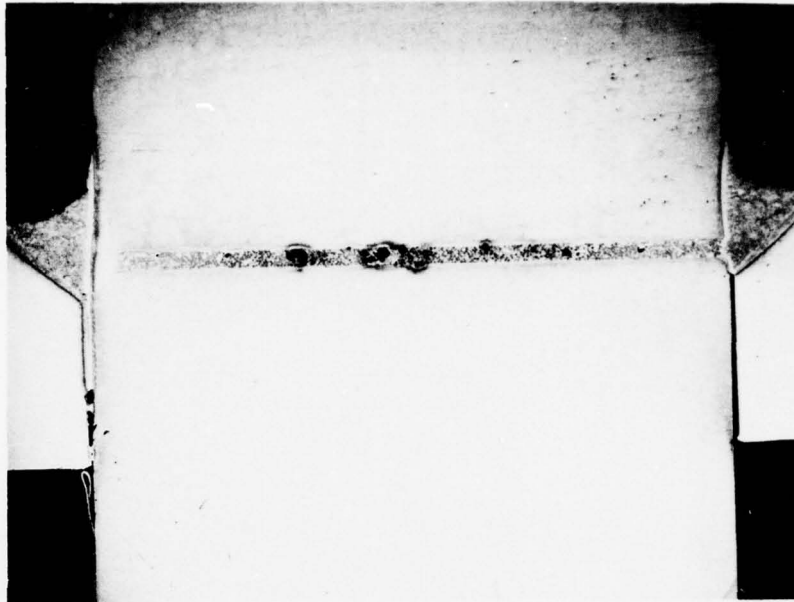

Kallings Etch 7X

Figure 24. Braze Joint with S2 Sinter Filler Metal Showing the Most Severe Porosity Observed, 16 mil

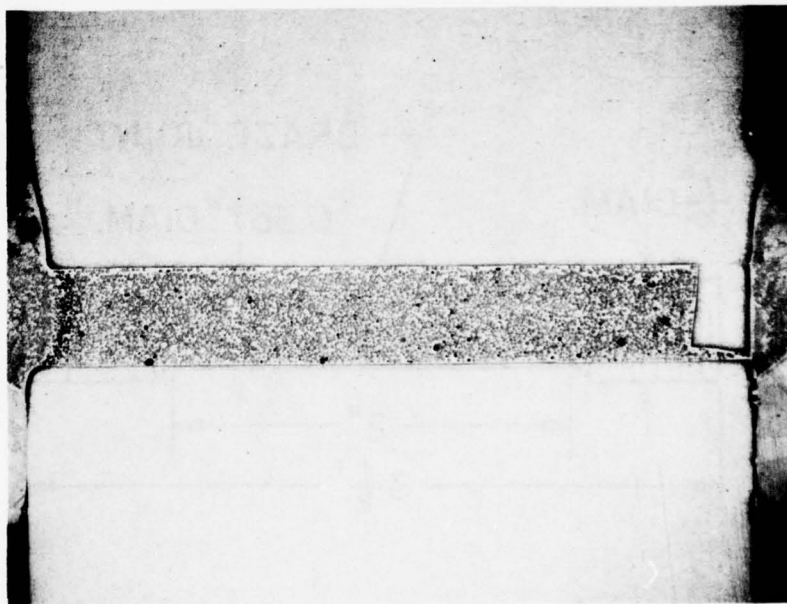

Kallings Etch 7X

Figure 25. Typical Braze Joint with S2 Sinter Filler Metal at Large Joint Clearance, 74 mil



Kallings Etch 7X

Figure 26. Braze Joint with S2 Sinter Filler Metal Which Had Cracked Before Brazing, 67 mil

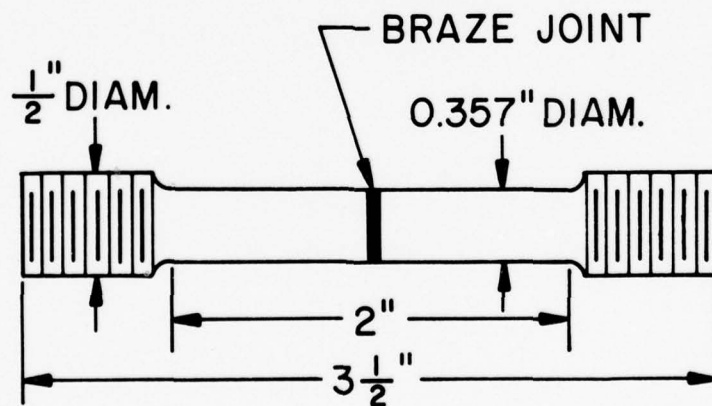

Figure 27. Tensile Test Specimen

SECTION VI

TENSILE TEST RESULTS

Tensile specimens, as shown in Figure 27, were made from braze specimens, either by turning or by centerless grinding followed by thread rolling. Base metal specimens, of the same dimensions, were also made by the same methods.

Stresses occurring during tensile specimen fabrication caused seven specimens with no sinter filler metal and one with S2 sinter filler metal to fracture. The joint clearance for the first six specimens was 10-15 mils and, for the latter specimen, 6 mils. Metallographic examination of diametral cross sections of the fracture faces showed failure of all joints with no sinter filler metal entirely confined to the centerline intermetallic compounds. The fracture for about two thirds of the S2 specimen diameter occurred along a line of intermetallic compounds in an area devoid of nodules. The cause of failure was therefore an incomplete fill with sinter filler metal.

Before tensile testing, the joint clearance was measured with a binocular microscope at 30X, after polishing and etching of the specimen circumference at the braze joint. At this point, a limited effort to examine the braze joints by fluorescent penetrant and radiographic means was made. Neither inspection method was successful. Visual examination of the braze joint surface with the binocular microscope at 30X proved adequate to detect surface flaws. From about 125 tensile specimens examined, two were rejected because of surface flaws.

6.1 TENSILE STRENGTH

Specimens were tested to establish the tensile strength at room and elevated temperatures of brazed joints at a nominal joint clearance of 10 mils and to determine the influence of joint clearance on tensile strength at room temperature and at 1700°F. Base metal specimens were also tensile tested at room and elevated temperatures.

Tabular data on the tensile test results for individual specimens is presented in Tables 7 through 10. All failures of brazed specimens occurred at the braze joint.

It is evident from the results contained in Table 7, that the two heats of Hastelloy X base metal are quite similar in their tensile strength at room and elevated temperatures and in their yield strength and tensile elongation at room temperature. Also, these same properties show little effect of exposure to the sinter and braze cycles used for brazing the joint tensile specimens.

TABLE 7
HASTELLOY X BASE METAL TENSILE TEST RESULTS

Heat	Test Temp. °F	Condition ^a	Tensile Strength ksi		Yield Strength ^c ksi	Elong. ^d %
			Single	Ave. ^b		
1	75	AR	108		46	63
1	75	S + B	110		40	50
2	75	AR	109		48	50
2	75	S + B	112	110	42	49
1	1200	AR	82			
1	1200	S + B	79			
2	1200	AR	80			
2	1200	S + B	81	80		
1	1700	S + B	34			
2	1700	AR	29			
2	1700	S + B	23	29		
1	2000	AR	9			
1	2000	S + B	11			
2	2000	AR	11			
2	2000	S + B	9	10		

- a. Condition: AR - As Received.
S + R - Sinter and Braze cycles of Figure 13.
- b. Average at each testing temperature.
- c. Yield strength at 0.2% strain.
- d. Gage length of 1 in.

TABLE 8

BRAZED JOINTS WITH NO SINTER FILLER METAL TENSILE TEST RESULTS

Joint No.	Test Temperature °F	Joint Clearance mil	Tensile Strength ksi		
			Single	Average ^a	Average ^b
1	75	1	67		
2	75	1	67		
3	75	2	80		
4	75	3	60		
5	75	5	63		
6	75	6	67		
7	75	9	19*		
8	75	11	15*	17	
9	75	15	15		
10	75	15	25		
11	75	23	10		
12	75	24	22		42
13	1200	10	19*		
14	1200	11	17*	18	18
15	1500	11	20*		
16	1500	11	21*	20	20
17	1700	3	24		
18	1700	4	23		
19	1700	6	23		
20	1700	8	22		
21	1700	10	24*		
22	1700	11	21*		
23	1700	11	22*	22	
24	1700	25	20		
25	1700	25	22		
26	1700	25	23		22
27	2000	10	0*		
28	2000	11	0*	0	0

a Average is calculated from single values with asterisk.

b Average is calculated from single values at a given temperature.

TABLE 9 (completed)

BRAZED JOINTS WITH S1 SINTER FILLER METAL TENSILE TEST RESULTS

Joint No.	Temperature °F	Clearance mil	Tensile Strength ksi		Failure Location and Other Fracture Face Features													
			Single	Average	Macroscopic Exam.					Metallographic Examination								
					Sintering Surface	Braze Metal	Flat Area %	Diffusion Zone	Sintering Surface	Braze Metal	Sinter Filler Metal	Linear Inter-metallics						
19	1700	5	31		X		80		X									
20	1700	6	20		X		30	X	X									X
21	1700	7	23		X		50	X	X								X	X
22	1700	7	29		X		0	X	X									
23	1700	7	32		X		0	X	X									
24	1700	9	25*				0	X										
25	1700	10	26*	26	X		25	X					X					X
26	1700	18	28				0	X										
27	1700	18	30				0	X										
28	1700	19	24				0	X										
29	1700	44	28				0	X										
30	1700	46	36				0	X										
31	1700	48	23				0	X										
32	1700	55	22				0	X										X
33	1700	62	24				0	X										
34	1700	63	23		26		0	X										
35	2000	10	0*	4			0	X										X
36	2000	10	9*	4			0	X										X

a Average is calculated from single values with asterisk.

b Average is calculated from single values at a given temperature.

TABLE 10
BRAZED JOINTS WITH S2 SINTER FILLER METAL TENSILE TEST RESULTS

Joint No.	Temperature °F	Clearance mil	Tensile Strength ksi	Failure Location and Other Fracture Face Features										
				Single Sinter	Average	Strength	Macroscopic Exam.	Failure Location and Other Fracture Face Features	Macroscopic Exam.	Failure Location and Other Fracture Face Features				
				Sin- gle	Avea Aveb	Strength	Fay- ing Sur- face	Braze Metal	Flat Area %	Diffu- sion Zone	Fay- ing Sur- face	Braze Metal	Sinter Filler Metal	Linear Inter- metallics
1	75	10	67*	X			X		0					
2	75	10	69*	X			X		0					
3	75	13	75*	X			X		0					
4	75	15	91	X			X		0					
5	75	19	66	X			X		0					
6	75	19	97	X			X		0					
7	75	33	62	X			X		5					
8	75	34	70	X			X		0					
9	75	45	70	X			X		0					
10	75	60	88	X			X		0					
11	75	61	71	X			X		0					
12	75	72	48	X		73	X		0		X	X	X	X
13	1200	12	49*	X			X		0	X				
14	1200	12	76*	X			X		0					
15	1200	13	56*	X			X		0	X	X			
16	1200	13	63*	X		61	X		0					
17	1500	9	20*	X			X		0			X	X	X
18	1500	11	47*	X			X		0			X	X	X
19	1500	13	38*	X		35	X		0			X	X	X

Average tensile strength values from Tables 7 through 10 are plotted in Figure 28 versus test temperature for base metal and brazed joints with a nominal joint clearance of 10 mils. The actual joint clearances varied from 9 to 13 mils, but it will be shown later that this range of joint clearance would not be expected to influence joint strength. For comparison purposes, handbook values for base metal are also included in Figure 28.

Figure 28 and Tables 7 through 10 show that the tensile strength of brazed joints with no sinter filler metal is very low at lower temperatures but becomes 76% of the base metal strength and 85% of the sinter filler metal joint strength at 1700°F, and then drops to zero at 2000°F. The strength of joints with no sinter filler metal, at clearances of 23-25 mils, was better than would have been predicted from the results of metallographic examination. Four of five such joints in Table 8 had strengths that are not consistent with the presence of cracks such as were found in the metallographic specimens.

The strength of joints with S2 sinter filler metal at room temperature, with 64% of the base metal strength, is about four times the strength of joints with no sinter filler metal. The S1 joints have 51% of the base metal strength at room temperature. The curves for both S1 and S2 sinter filler metals are distorted by the inclusion of low tensile strength results of joint 35 of Table 9 in the average for S1 at 2000°F and joint 17 of Table 10 in the average for S2 at 1500°F. Subsequent examination of these joints revealed that both joints were defective. If the tensile strength values for both of these joints are excluded from the averages, the average at 1500 and 2000°F are about equal for S1 and S2. On this basis, a comparison of sinter filler metal joints with values midway between the two base metal curves of Figure 28 shows that above approximately 800°F, the tensile strength of S1 and S2 joints are similar at about 70 - 85% of the base metal strength.

All of the tensile strength values at room temperature for brazed joints from Tables 8 through 10 are plotted in Figure 29. At low clearance, joints brazed with no sinter filler metal have high strength comparable to that of joints with sinter filler metal. However, the joint strength drops rapidly to a low value at clearances greater than approximately 6 mils.

The straight line relationships in Figure 29 for joints with sinter filler metals S1 and S2 were estimated by the method of least squares. These curves show that the higher strength of S2 joints found at a nominal joint clearance of 10 mils, also applies at all joint clearances tested. The strength of joints brazed with S1 remains essentially constant at 60 ksi, which is 54% of the base metal strength. The curve for S2 joints indicates some decrease in strength with increasing clearance; however, this is not a true representation. Subsequent examination revealed that joint 12 of Table 10, which represents the point plotted at 72 mils in Figure 29, had a severe braze defect. If this value is eliminated, the resulting relationship is a constant strength of about 75 ksi (68% of base metal strength) for all joint clearances tested.

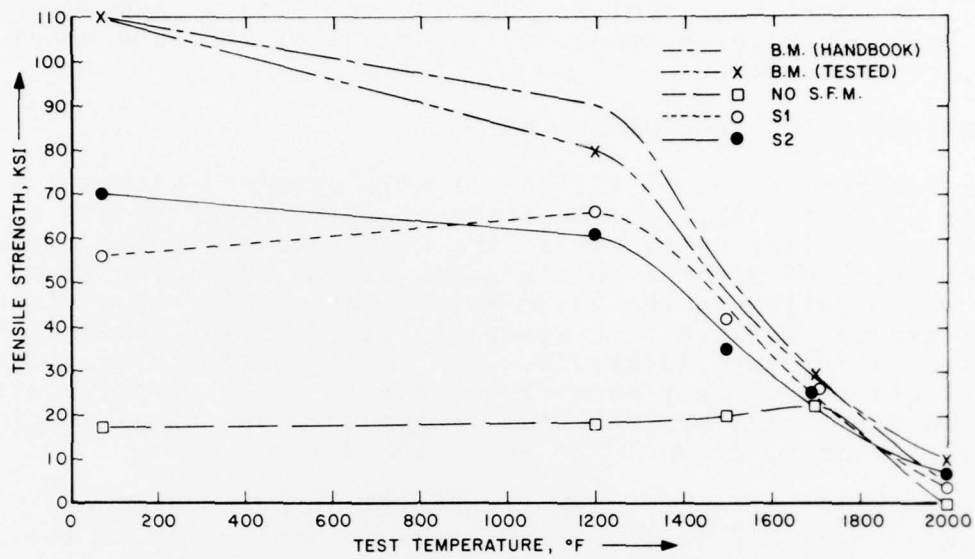

Figure 28. Tensile Strength vs. Test Temperature for Base Metal and Braze Joints with a Nominal Clearance of 10 mils

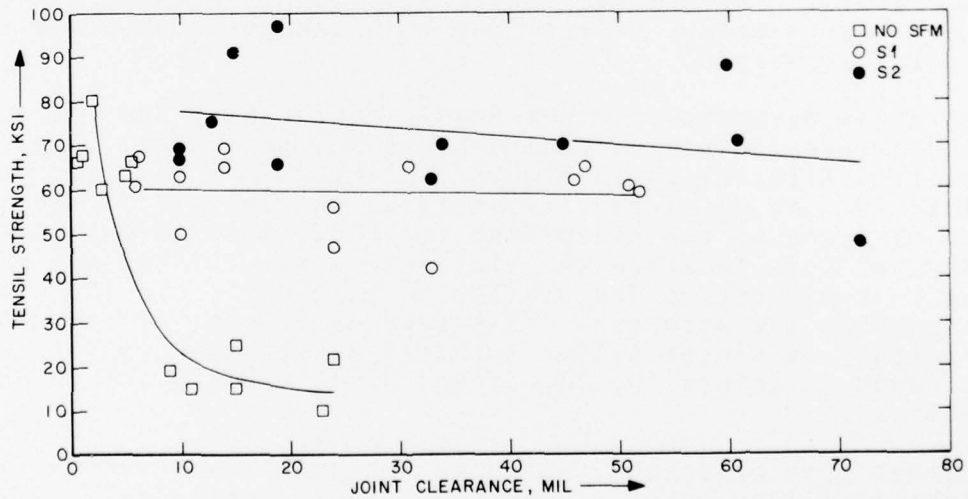

Figure 29. Tensile Strength vs. Joint Clearance at Room Temperature for Braze Joints

All of the tensile strength values at 1700⁰F for brazed joints from Tables 8 through 10 are plotted in Figure 30. Straight lines were fitted to the values for each of the joint filler metal types by the method of least squares. The influence of joint clearance was very low for all types. The tensile strength of joints with no sinter filler metal was about 22 ksi and, for both S1 and S2 joints, about 26 ksi. This corresponds to 76 and 80% of the base metal strength, respectively.

6.2 EXAMINATION OF FRACTURE FACES

The fracture faces of all joints were examined with a binocular microscope at 10 to 30X. The location of failure for joints brazed with no sinter filler metal was at the center of the braze metal for joint clearances of greater than 8 mils, except for joint 11 of Table 8, which failed in the braze metal near one faying surface. At lesser clearance, failure took place at either faying surface, in the braze metal, or at both locations. The faying surfaces of joints 1 and 2 of Table 8 were only about 50% brazed. If the tensile strength is based on the actual brazed area, rather than the cross section of the tested specimen, it would be about 130 ksi.

A selection of joints with sinter filler metal was metallographically examined as a cross section perpendicular to the faying surface. The results of both the macroscopic examination with the binocular microscope and the metallographic examination are given in Tables 9 and 10.

In general, the failure location of joints with S1 sinter filler metal changed from the faying surface at low joint clearance and room temperature to a mixed faying surface - braze metal location, and then changed to braze metal failure at large joint clearance and high temperature. The failure location of joints with S2 sinter filler metal was similar, except that both changes took place at greater joint clearance.

The metallographic examination of joints which had failed at low strength revealed braze metal defects in most cases. The most detrimental is illustrated in Figure 31, which is taken from joint 17 of Table 10. No S2 sinter filler metal nodules are present and failure took place at the centerline intermetallic microstructure. Apparently, at this location the sinter filler metal had not filled, resulting in a microstructure similar to that of Figure 19, with its accompanying low strength. This type of defect, or one caused by a deficiency of sinter filler metal rather than a complete absence, was also found in joints 10, 20, 21 and 35 of Table 9 and in joint 12 of Table 10.

Another type of defect, noted in one joint, was incomplete fill of the brazing filler metal. Figure 32, representing joint 27 of Table 10, illustrates this type of defect. The location of the photomicrograph is at the transition from an area on the right filled by the brazing filler metal to an area on the left devoid

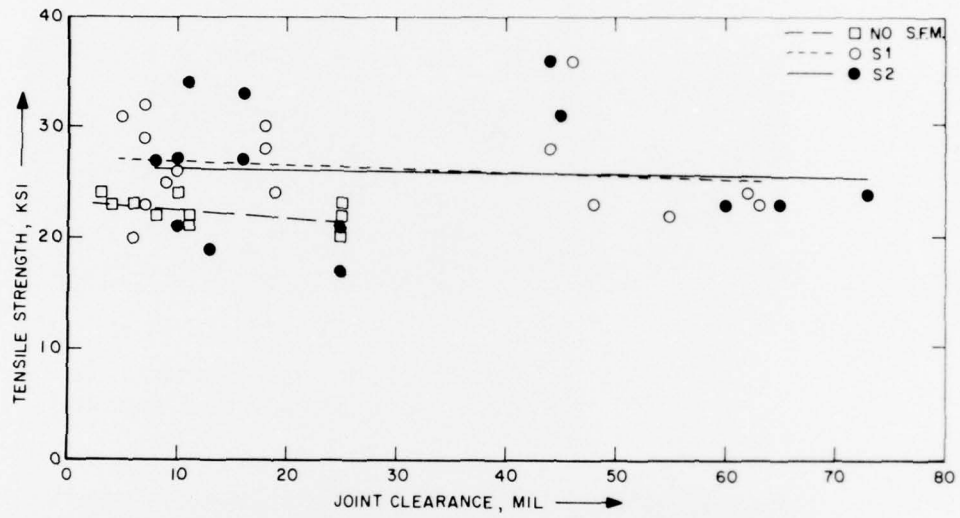
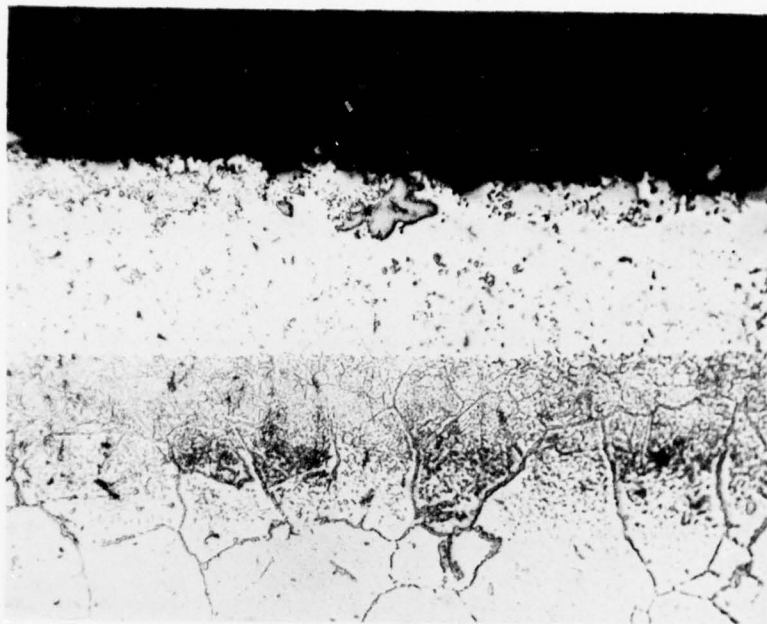
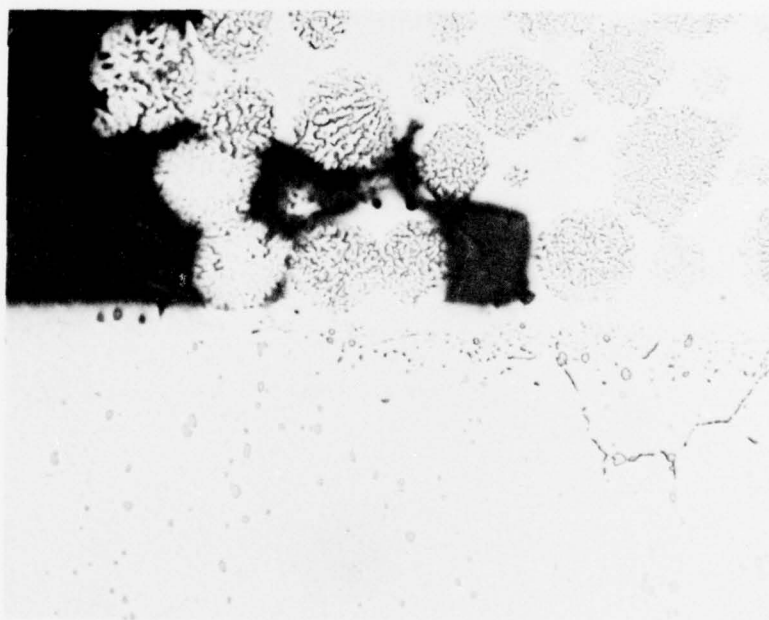

Figure 30. Tensile Strength vs. Joint Clearance at 1700°F for Braze Joints



Kallings Etch 200X

Figure 31. Cross Section of Fracture in Linear Intermetallic Compounds



Kallings Etch 200X

Figure 32. Cross Section of Fracture Showing Incomplete Fill of Brazing Filler Metal

of filler metal. The absence of the typical base metal diffusion zone microstructure on the left and the interstitial voids in the center indicate that at no time was brazing filler metal in contact with base metal.

The failure of the lowest strength joint at each temperature and for both sinter filler metals, where the joint strength was less than 80% of the average strength, was caused by incomplete fill of the sinter filler metal in five joints and incomplete fill of brazing filler metal in one joint.

Metallographic examination of some joint fracture faces revealed that although the macroscopic examination had identified a faying surface fracture, the actual failure had occurred in the diffusion zone adjacent to the faying surface, as illustrated in Figure 33 for joint 18 of Table 9. Joints with this type of failure had a tensile strength lower than the average for the group tested at the same temperature and containing the same sinter filler metal. However, the difference was small; 13 to 19% of the average strength. Joint 10 of Table 9 is not included in this assessment, since the cause of its low strength was the presence of linear intermetallic compounds at another location in the braze metal.

A typical fracture, at test temperatures of 1200°F and above, in braze metal with S2 sinter filler metal is shown in Figure 34 from joint 17 of Table 10. The fracture characteristically did not take place through the sinter filler metal nodules, but followed a path at their periphery. This suggests that closer spacing of nodules, such as shown by sinter filler metals S3 and S4 in Figures 7 and 8, would result in increased braze metal strength due to a greater stiffening effect on the interstitial phase, where fracture occurs.

Figure 35 is a photomicrograph of a fracture in a joint with S1 sinter filler metal (joint 32 of Table 9), indicating isolated cracks in the interstitial phase, believed to be a boride, at some distance from the fracture face. The tension load in the specimen was parallel to the longer axis of the photograph; i.e., perpendicular to the crack direction. This behavior suggests brittleness of the interstitial phase, which did not allow its accommodation by plastic deformation to plastic flow in the surrounding material, as tensile deformation proceeded.

An unusual feature of some fractures is shown in Figure 36, where planar failure occurred over a large part of the fracture face. The clear evidence of grinding striations indicates that the fracture face is the original faying surface. As may be observed from the columns headed "flat area" in Tables 9 and 10, this behavior was confined to joint tested at 1700°F. This type of failure did not cause low strength; in fact, these joints were distinguished by their high strength. Figure 36 is from joint 30 of Table 10, with about 90% of the fracture face consisting of the planar faying surface failure. The tensile strength was 31 ksi, compared to an

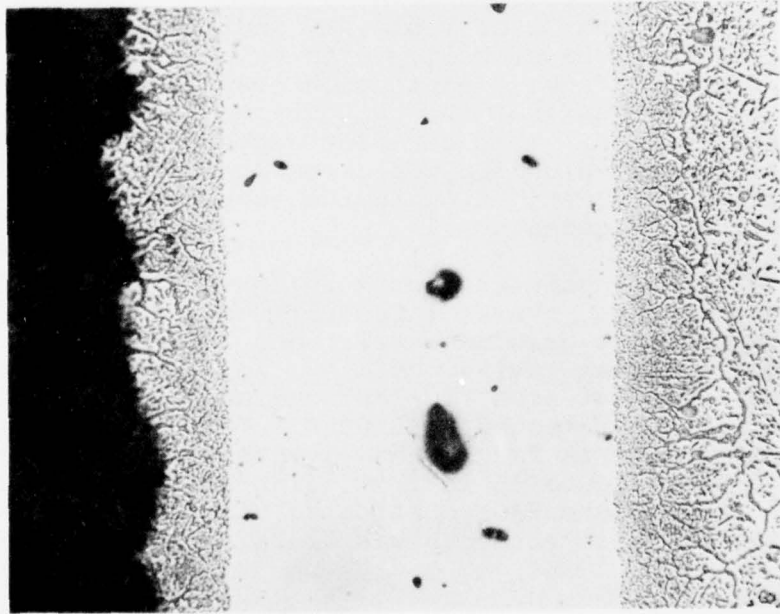

Kallings Etch 200X
Figure 33. Cross Section of Fracture
in Diffusion Zone of Base
Metal

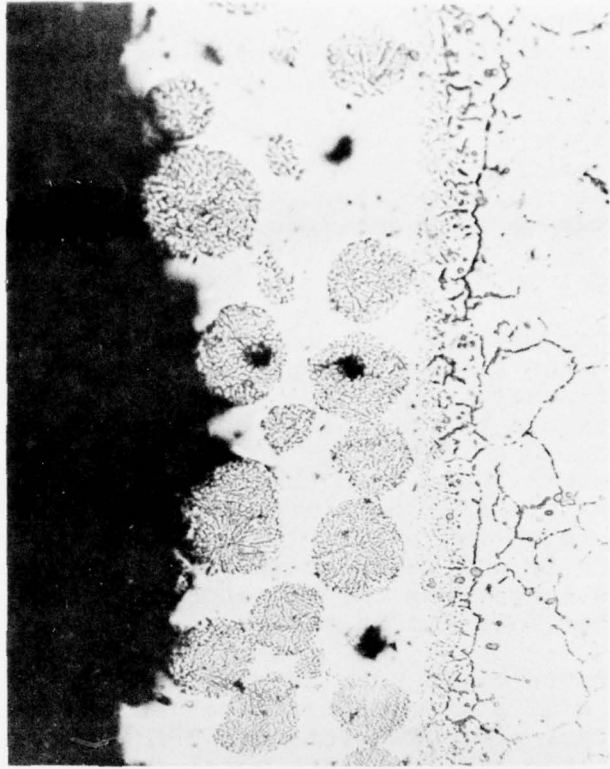

Kallings Etch 200X
Figure 34. Cross Section of Fracture in
Joint with S2 Sinter Filler
Metal

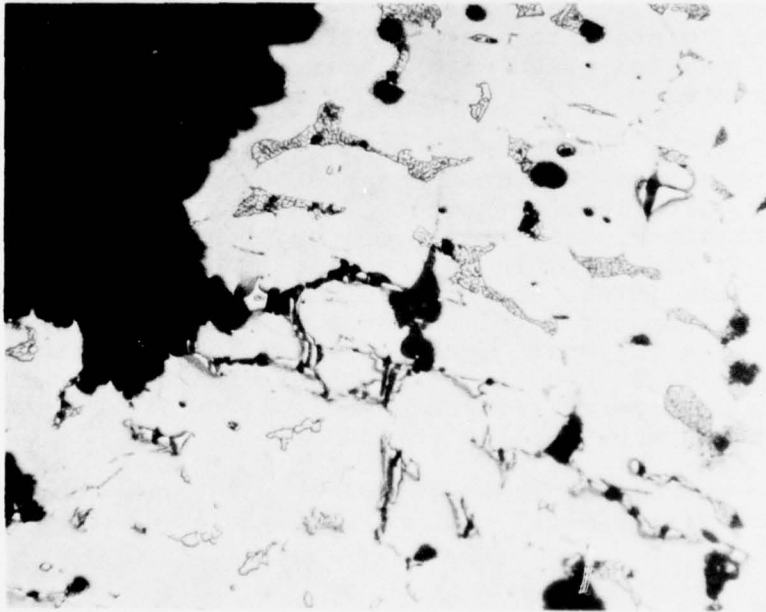

Kallings Etch 200X

Figure 35. Cross Section of Fracture in Joint with Si Sinter Filler Metal

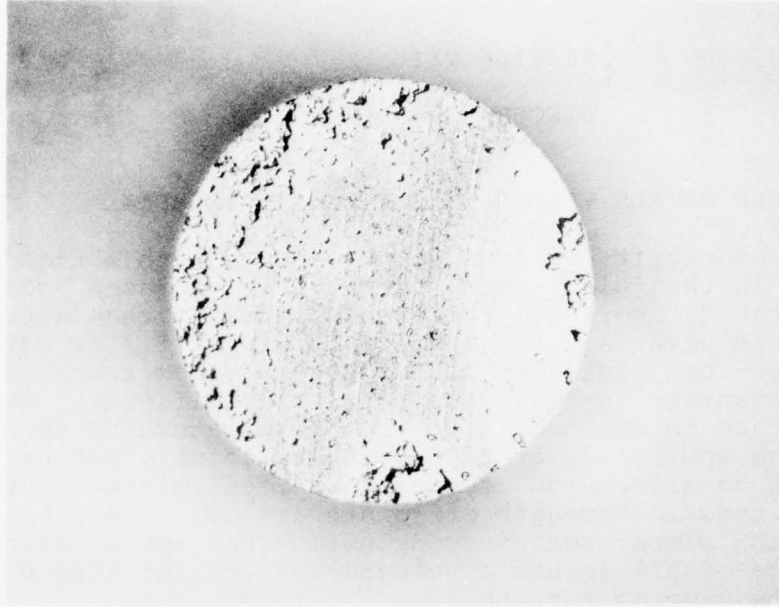

7X

Figure 36. Fracture Face Showing Planar Failure at Faying Surface

average of 26 ksi. If joints 20 and 21 of Table 9 and joint 27 of Table 10 are excluded from consideration (these joints had braze metal defects), the minimum tensile strength was 23 ksi and the average was 29 ksi for joints exhibiting some planar failure at the faying surface.

SECTION VII

DISCUSSION

7.1 SINTER FILLER METALS VERSUS NO SINTER FILLER METAL

The clear superiority of butt joints brazed with a high melting metal powder in the joint, over conventionally brazed joints, has been demonstrated. For joint clearances greater than approximately 6 mils, this advantage of joints with sinter filler metal is particularly large for joint tensile strength at room temperature; at 1700°F, the advantage is small but remains significant. This very large advantage is extended from room temperature up to about 1500°, and is also applicable at 2000°F, for a joint clearance of about 10 mils. A consideration of the braze metal microstructural features and the tensile strength of joints at room temperature and 1700°F leads to the almost certain conclusion that the tensile strength advantage of all joints at clearances greater than 6 mils would be about the same as for the 10-mil joints.

A joint clearance of about 20-25 mils is considered the upper limit for reliable joints with no sinter filler metal, because of the prevalence of major braze metal defects at greater clearances.

Only at joint clearances of about 6 mils and less does the room temperature tensile strength of joints with no sinter filler metal equal that of joints with sinter filler metal. The tensile strength at 1700°F favors joints with sinter filler metal at all joint clearances tested.

In addition to the low strength of joints with no sinter filler metal at clearances greater than about 6 mils, there were indications of low ductility. A number of the brazed specimens fractured under the shock, vibration, torsion, bending or other loads applied during the machining of tensile specimens. The tensile strength of these joints at about 15 ksi is not sufficiently low to explain this behavior. The presence of a continuous layer of very hard phases in the braze metal is conducive to brittle behavior. The increase in tensile strength exhibited by the braze joint, as the test temperature is increased to 1700°F, is characteristic of brittle intermetallic compounds.

At the other extreme of the joint clearance range, complete fill by the brazing filler metal was not achieved at 1-mil clearance.

The clearance of brazed joints with no sinter filler metal, at which high strength and good ductility may be achieved, is limited to the narrow range of about 2 to 6 mils. In addition, even low strength joints are limited to a maximum of about 20 mils clearance. On the other hand, joints with S2 sinter filler metal exhibited high strength and no indications of brittle behavior over the entire joint clearance range tested; i.e., from 8 to 73 mils.

7.2 SINTER FILLER METALS

The extent of the effort devoted to each of the sinter filler metals was determined by the time at which each was introduced into the program. Therefore, the amount of work expended on a given sinter filler metal does not necessarily correspond to the assessment of its value for the production of brazed joints.

The program started with S1. About midway through the program S2, and near the end, S3 and S4 were introduced. Extensive work was done on both wafers and brazed joints with S1 and on brazed joints with S2. A minor effort was expended near the end of the program on wafers with S2. Experimentation with S3 and S4 was limited to a preliminary study of wafers.

The purpose of the extensive work on wafers with S1 was an attempt to find a means of eliminating the excessive porosity of brazed joints with this sinter filler metal. The later emergence of another successful sinter filler metal relegated this porosity problem to a position of lesser importance.

A comparison of the complete results for S1 and S2 leads to the conclusion that S2 is the better sinter filler metal. The tensile strength of brazed joints with S2 is higher at room temperature and 1200°F, and is equal at higher temperatures. Although the high temperature tensile strength results did not show a difference between S1 and S2, the Mo and W additions to S2 should confer better high temperature properties on braze joints with S2 than with S1, which contains no Mo and W. This potential advantage might be realized for other high temperature properties, such as stress rupture strength or creep strength. Other joint properties such as fatigue strength or ductility may be unfavorably influenced by the much greater porosity of braze joints with S1.

A low volume decrease from the green to the sintered condition is advantageous in the braze repair of cracks, as will be explained later. In this respect, S2 is a better sinter filler metal than S1.

In addition, from microstructural considerations, it appears that better ductility would be expected with S2 than with S1. Braze metal with S2 consists of hard nodules embedded in a solid solution matrix. The nodules are composed of isolated fine precipitates embedded in a matrix, which appears to be the same phase as the matrix surrounding the nodules. On the other hand, braze metal with S1 contains a semi-continuous network of phases, which

includes a massive phase, tentatively identified as a boride. The increase in tensile strength from room temperature to 1200°F for brazed joints made with S1, which is not normal for a non-precipitation hardening alloy, may be an indication of low ductility.

From the results of the wafer study, it is anticipated that the use of S3, which is a finer powder of the same composition as S2, would yield brazed joints with better mechanical properties than joints with S2. Despite the small difference in sinter porosity between S2 and S3, the resulting brazed wafers with S3 exhibited considerably closer packing of the sinter filler metal. Although incomplete fill with brazing filler metal of joints made with S2 was minimal, the better fill for S3 wafers than for S2, indicates that incomplete fill should be eliminated with S3.

Sinter filler metal S4 is also promising. It was predicted that the presence of Al and Ti in S4 would cause poor fill of the sintered wafer by the brazing filler metal. It is known that these elements; or more precisely, their oxides, often prevent good wetting and flow. This did not prove to be the case. The fill of the sinter filler metal wafers was virtually complete.

The microstructure of S4 brazed wafers is also favorable. It consists of closely packed nodules which are sufficiently disintegrated to produce a more uniform distribution than is the case with any of the other sinter filler metals. It remains to be seen whether or not the fragile nature of the S4 sinter would cause difficulty in the production of brazed joints.

7.3 WAFER STUDIES

Preliminary experiments with brazed wafers is considered to be almost indispensable for the efficient gathering of information useful in subsequent joint brazing. The fabrication of wafers is more economical in materials and in labor than the brazing of joints.

The conditions for obtaining sound braze metal with a maximum content of sinter filler metal may be determined by wafer experimentation. This begins with the sintered wafer. Information about the effect of sinter filler metal composition and particle size, cement and solvent amount, and sintering conditions on the density, cracking, and strength of the resulting sintered wafer may be obtained. The effect of brazing conditions and brazing filler metal composition and amount on the degree of fill, microstructure and defects (such as cracks and porosity) of the brazed wafer, may also be determined.

Obviously, wafer studies cannot eliminate the need for the fabrication of brazed joints, but they do appreciably reduce the required number of such joints. The interaction of base metal and brazing filler metal has considerable effect on the braze metal of

joints with low clearance, but the braze metal microstructure of wide clearance joints is identical to that of brazed wafers, except for a narrow zone at each faying surface.

Other differences between brazed wafer and brazed joint behavior were noted. The fill of S2 sinter filler metal by brazing filler metal in joints was better than that predicted from the wafer experiments. From the greater flow distance for brazed joints than for the brazed wafers, just the opposite behavior would be expected. Apparently, the presence of the base metal surfaces on either side of the sinter filler metal in a braze joint improves flow by an increase in the capillary forces acting on the brazing filler metal. The brazed wafer results were consistent with the brazed joint results regarding the degree of fill, when a comparison of S1 and S2 is made. In both cases, the fill was better with S1, although incomplete fill of brazed joints with S2 was of little significance.

Another difference in the behavior of brazed wafers versus brazed joints was the effect of the ratio of brazing filler metal to sinter filler metal S1. A small excess of brazing filler metal caused the wafer to melt completely when the brazing time was extended from two to four hours. However, there was no evidence of bulk melting in brazed joints which were completely filled with sinter filler metal when a much larger excess of brazing filler metal was used. The brazing temperature was the same in both cases, but the brazing time for joint brazing was two hours. Nevertheless, the high percentage of brazing filler metal should have caused complete fusion of the braze metal in the brazed joint.

The probable explanation of this apparent discrepancy was the presence of the feeder ring and the base metal. Both of these alloy with the brazing filler metal, thus increasing its melting point to the brazing temperature. Thereupon the resulting alloy solidifies and no further dissolution of the sinter filler metal can take place. The limited access of the brazing filler metal to the sinter filler metal at a narrow band around the joint periphery would also restrict the degree of fusion of the sinter filler metal.

7.4 POROSITY WITH S1 SINTER FILLER METAL

The extensive search for the cause of the excessive porosity in braze joints with S1 sinter filler metal remained fruitless. The excessive porosity was peculiar to S1. Without exception, when S1 was present in the braze metal, whether it was as a brazed wafer or as a braze joint, the excessive porosity was also present. When S1 was absent, the porosity was low. This was true for two lots of S1.

It has been established that the pores resulted from the entrapment of a gas, but both the source and the nature of the gas is unknown. Also, no means of obtaining an appreciable reduction in the extent of the porosity was found.

7.5 APPLICATION TO REPAIR BRAZING

A number of factors must be considered in the application of the brazing method described in this report to the repair of gas turbine engine components. In the brazing of a crack, one is confronted with a fixed joint, which cannot be disassembled for surface cleaning or the introduction of sinter filler metal. The joint clearance varies from wide at the mouth of the crack to zero at its tip. Usually there are multiple cracks of various orientations.

Standard cleaning methods such as immersion in hot alkaline solutions, grit blasting, pickling in acid solutions, and high temperature annealing in hydrogen gas were found to produce faying surfaces of solid solution nickel-base alloys suitable for brazing. The very small opening at a crack tip presents a cleaning problem. However, a lack of fill by filler metal at the crack tip, due to inadequate cleaning, is not believed to be a serious problem. The highest service stress is located where the crack started; i.e., at the mouth of the crack, not at the crack tip.

The technique for filling cracks, prior to sintering, involves the use of a spatula to press a paste mixture of sinter filler metal and cement into the cracks. Acetone may be added to the mixture to yield a paste of the proper consistency for filling a crack of a given depth and opening displacement.

The filling of cracks with sinter filler metal at locations of less than 6-mil joint clearance is not necessary. The flow of brazing filler metal into these areas will produce a joint of high strength and probably good ductility, without sinter filler metal. However, if cracks of greater than 6-mils clearance contain no sinter filler metal, the resulting braze joint will be of low strength and low ductility. This is also true for cracks which are less than completely filled, but the minimum degree of fill that will prevent the formation of brittle, linear intermetallic compounds, which cause poor joint properties, has not been established. For this reason, crack areas with less than complete fill must be avoided, if possible, or limited in length and frequency.

Care must be taken to ensure complete fill with sinter filler metal at the mouth of the crack. If a cross section of the crack intersection with the surface of the part is considered, the sinter filler metal must be at least flush with the surface of the part. Any shrinkage due to evaporation of solvent from the cement may be compensated for by adding sinter filler metal above the surface of the part, at the mouth of the crack. After sintering, excess sinter filler metal should be removed before brazing, which can be done by scraping with a sharp tool. However, if there is shrinkage during brazing, sufficient excess sinter filler metal must be left to account for this shrinkage.

The ideal amount of brazing filler metal, added as a paste of brazing filler metal and cement at the mouth of the crack on top of the sinter filler metal, is that required to fill the pores of the sinter filler metal. This corresponds to a volume of filler metal paste equal to approximately two-thirds of the volume of the crack being brazed. The sinter filler metal contains about one third of its volume as porosity and the brazing filler metal paste has a brazing filler metal content of about one half of its volume. Since it is impractical to determine the crack volume accurately, a volume of brazing filler metal paste approximately equal to the crack volume should be applied, to provide a small excess of brazing filler metal. A large excess must be avoided, to prevent too much erosion of the sinter filler metal or the presence of too much brazing filler metal, unfilled by sinter filler metal, at the mouth of the crack. A small excess will be sufficiently dissipated by flow on the part surfaces adjacent to the crack.

The repair of gas turbine engine components, at surfaces which have been worn away by erosion or abrasion during engine operation, may be accomplished by a surfacing variation of the method used for the repair of cracks. A slurry of sinter filler metal, cement, and solvent is sprayed on the component surface to deposit the required thickness of sinter filler metal. After sintering, the part is brazed with a volume of brazing filler metal paste equal to about two-thirds of the sinter volume.

If the area being surfaced requires close tolerances, the sinter filler metal is deposited in a greater thickness than needed. After sintering and brazing, the deposit is finished by grinding to the specified dimensions. The sintering and brazing steps for surfacing may be carried out at the same time as the repair of cracks.

Other repair applications of the brazing method described in this report include the back brazing of fusion welds at corner and edge joints, and the formation of fillets at lap, corner, and T-joints. The latter application may be either in combination with welds or alone.

7.6 APPLICATION TO THE FABRICATION OF NEW COMPONENTS

Conventional brazing methods are normally sufficient to produce joints with nickel-base filler metals of adequate mechanical properties. However, close tolerances are necessary, in order to maintain the joint clearances of about 2 to 6 mils which results in braze joints of good tensile strength and ductility.

In some cases, it would be more economical to increase the tolerances, and compensate for the resulting increase in the maximum joint clearance by incorporating a sinter filler metal in the braze metal. This approach would be especially advantageous when mating parts have a nonuniform or compound curvature of the faying surfaces.

The flow characteristics of nickel-base brazing filler metals usually cause small braze fillets to be formed. At the same time, the fillet thickness, combined with limited diffusion of melting point depressants into the base metal, may be sufficient to result in fillets of low ductility.

Both of these disadvantages may be corrected by the formation of large fillets with sinter filler metal. The larger fillet reduces stress concentration and the presence of sinter filler metal improves ductility.